

# Rosemount™ 5400 Level Transmitter

## Non-Contacting Radar



## 1.0 About this guide

This Quick Start Guide provides basic guidelines for the Rosemount 5400 Level Transmitter.

Refer to the Rosemount 5400 [Reference Manual](#) for more instructions. The manual and this guide are also available electronically on [Emerson.com/Rosemount](http://Emerson.com/Rosemount).

### **▲ WARNING**

**Failure to follow safe installation and service guidelines could result in death or serious injury.**

- Make sure the transmitter is installed by qualified personnel and in accordance with applicable code of practice.
- Use the equipment only as specified in this Quick Start Guide and the Reference Manual. Failure to do so may impair the protection provided by the equipment.
- Do not perform any services other than those contained in this manual unless you are qualified.
- Any substitution of non-authorized parts or repair, other than exchanging the complete transmitter head or antenna assembly, may jeopardize safety and is prohibited.

**Explosions could result in death or serious injury.**

- Verify that the operating environment of the transmitter is consistent with the appropriate hazardous locations specifications. See “[Product Certifications](#)” on page 21.
- To prevent ignition of flammable or combustible atmospheres, disconnect power before servicing.
- Before connecting a HART®, FOUNDATION™ Fieldbus, or Modbus® based communicator in an explosive atmosphere, make sure the instruments in the loop are installed in accordance with intrinsically safe or non-incendive field wiring practices.
- To avoid process leaks, only use O-rings designed to seal with the corresponding flange adapter.

**Electrical shock can result in death or serious injury.**

- Avoid contact with the leads and terminals. High voltage that may be present on leads can cause electrical shock.
- Make sure the main power to the Rosemount 5400 Level Transmitter is off and the lines to any other external power source are disconnected or not powered while wiring the transmitter.
- Ground device on non-metallic tanks (e.g. fiberglass tanks) to prevent electrostatic charge build-up.

**Antennas with non-conducting surfaces.**

Antennas with non-conducting surfaces (e.g. Rod antenna and Process Seal antenna) may generate an ignition-capable level of electrostatic charge under certain extreme conditions.

Therefore, when the antenna is used in a potentially explosive atmosphere, appropriate measures must be taken to prevent electrostatic discharge.

---

### Contents

Confirm system readiness (4-20 mA only) .....	page 3
Mount the transmitter head/antenna .....	page 4
Prepare the electrical connections .....	page 11
Connect wiring and power up .....	page 15
Configure .....	page 19
Safety Instrumented Systems (4-20 mA only) .....	page 20
Product Certifications .....	page 21

## 2.0 Confirm system readiness (4-20 mA only)

### 2.1 Confirm HART revision capability

This transmitter can be configured for either HART Revision 5 or 7. If using HART-based control and asset management systems, confirm the HART capability of those systems prior to transmitter installation. Not all systems are capable of communicating with the HART Revision 7 protocol.

### 2.2 Confirm correct device driver

- Verify the latest device driver (DD/DTM™) is loaded on your systems to ensure proper communication. See [Table 1](#).
- Download the latest device driver from [EmersonProcess.com/DeviceFiles](http://EmersonProcess.com/DeviceFiles).

**Table 1. Rosemount 5400 Device Revisions and Files**

Firmware version <sup>(1)</sup>	Find device driver	
	HART universal revision	Device revision <sup>(2)</sup>
2A0 and later	7	3
	5	2
1C0 - 1D0	5	2

1. Firmware version is printed on the transmitter head label, e.g. SW 2C.0.

2. Device revision is printed on the transmitter head label, e.g. HART Dev Rev 3.

### 2.3 Switch HART revision mode

If the HART configuration tool is not capable of communicating with HART Revision 7, the device will load a generic menu with limited capability.

To switch the HART revision mode from the generic menu:

1. Locate the “Message” field.
2. In the *Message* field, enter **HART5** or **HART7** and then 27 trailing spaces.

## 3.0 Mount the transmitter head/antenna

### 3.1 Cone antenna with flange

**Step 1: Lower transmitter with antenna and flange into the nozzle**

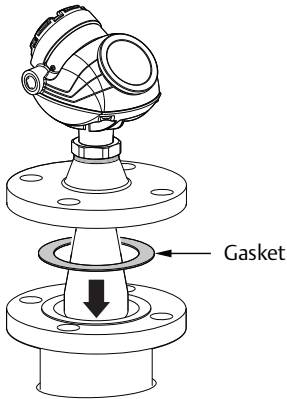

**Step 2: Tighten bolts and nuts**

Tighten bolts and nuts with sufficient torque for the flange and gasket choice.

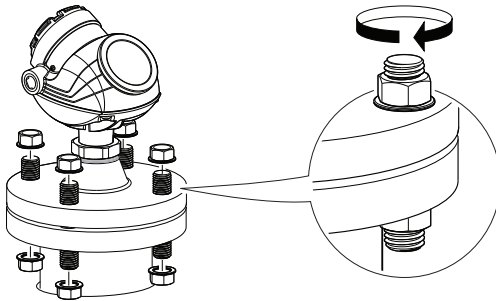

**Step 3: Adjust display orientation (optional)**

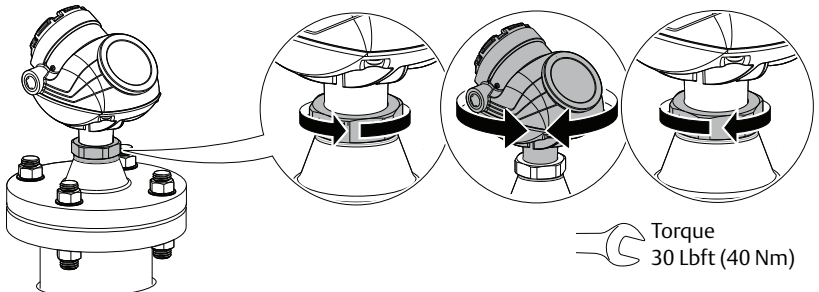

### 3.2 Process seal antenna with flange<sup>(1)</sup>

#### Step 1: Place antenna on top of the nozzle and mount flange

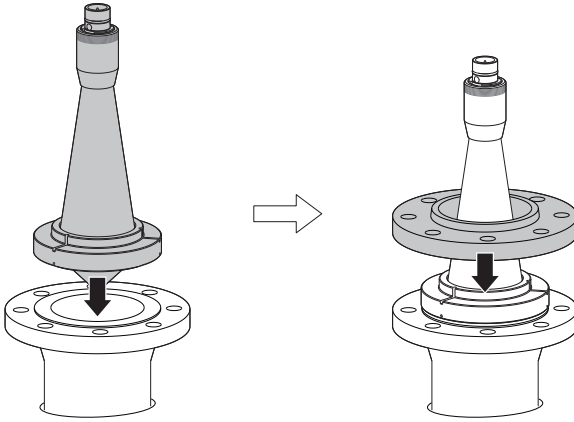

#### Step 2: Tighten bolts cross-wise

For torque information, see table.

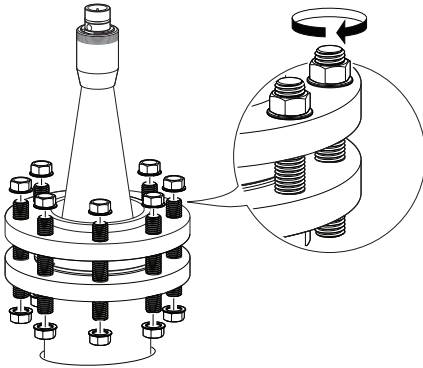

Process seal flange	Torque	
	(Nm)	(Lbft)
2 in., 150 lb.	40	30
2 in., 300 lb.	40	30
3 in., 150 lb.	60	44
3 in., 300 lb.	60	44
4 in., 150 lb.	50	37
4 in., 300 lb.	50	37
DN 50 PN 40	40	30
DN 80 PN 40	60	44
DN 100 PN 16	50	37
DN 100 PN 40	50	37
50A 10K	40	30
80A 10K	60	44
100A 10K	50	37
150A 10K	50	37

1. The mounting information applies to the updated Process Seal antenna design, released in February 2012. Antennas manufactured before this date have wetted O-rings and require a different installation procedure.

### Step 3: Mount transmitter head and tighten nut

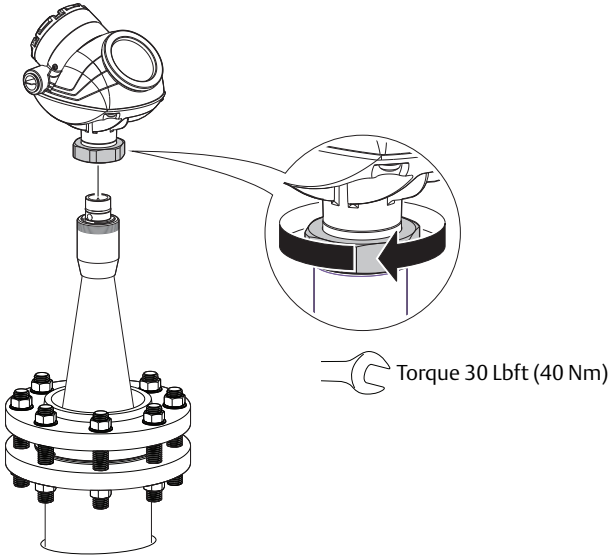

### Step 4: Re-tighten flange bolts after 24 hours

### 3.3 Rod antenna with threaded connection

#### Step 1: Lower transmitter with antenna into the tank

Tank connections with NPT threads require a sealant for pressure-tight joints.

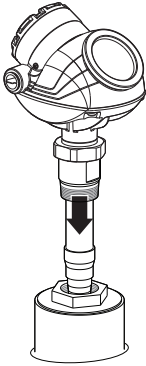

#### Step 2: Turn tank seal adapter until properly secured in the process connection

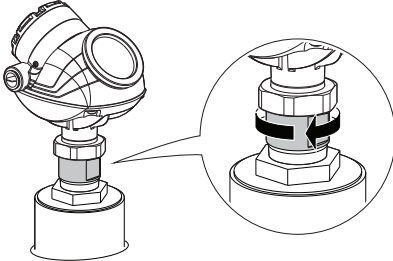

#### Step 3: Adjust display orientation (optional)

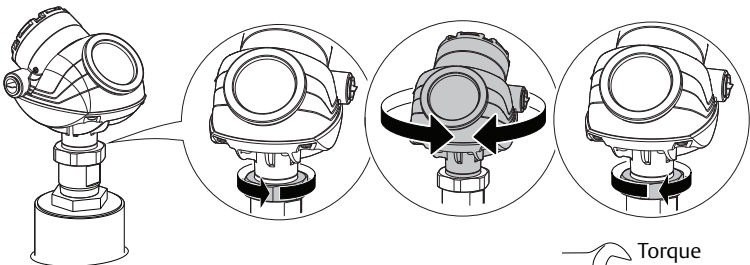

 Torque  
30 Lbft (40 Nm)

### 3.4 Rod antenna with flange

#### Step 1: Lower transmitter with antenna and flange into the nozzle

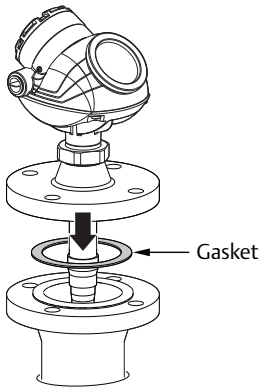

#### Step 2: Tighten bolts and nuts

Tighten the bolts and nuts with sufficient torque for the flange and gasket choice.

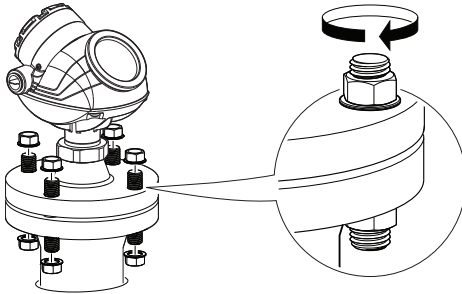

#### Step 3: Adjust display orientation (optional)

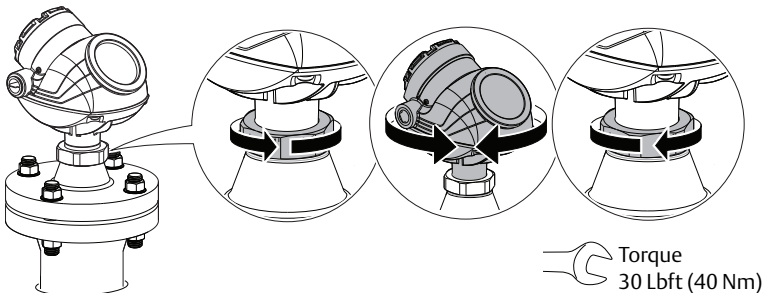



### 3.5 Tri Clamp tank connection

#### Step 1: Lower transmitter with antenna into the nozzle

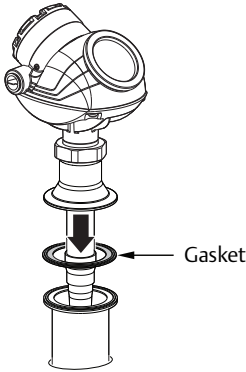

#### Step 2: Fasten Tri Clamp to the tank with a clamp

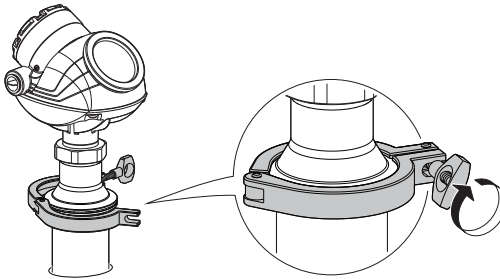

#### Step 3: Adjust display orientation (optional)

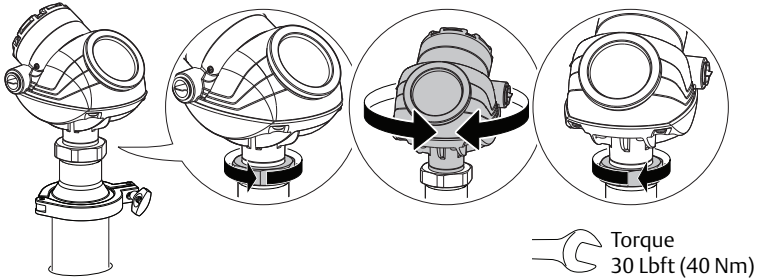

## 3.6 Bracket mounting

### Step 1: Mount the bracket to the pipe/wall

#### On pipe

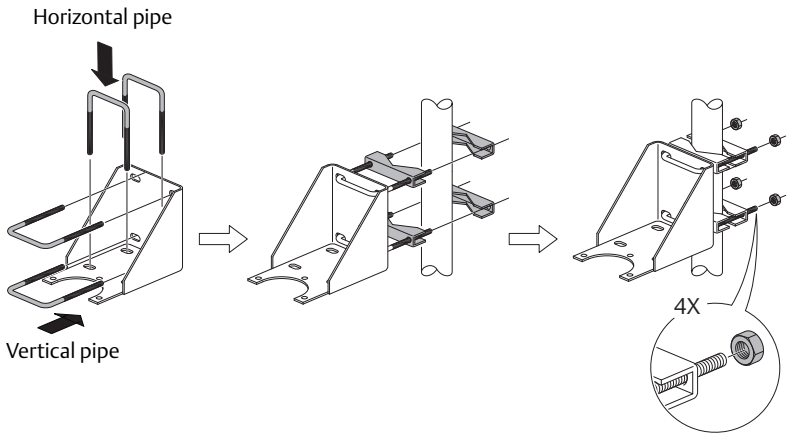

#### On wall

Use screws suitable for the purpose.

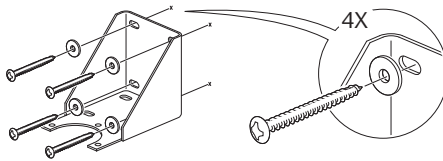

### Step 2: Mount the transmitter with antenna to the bracket

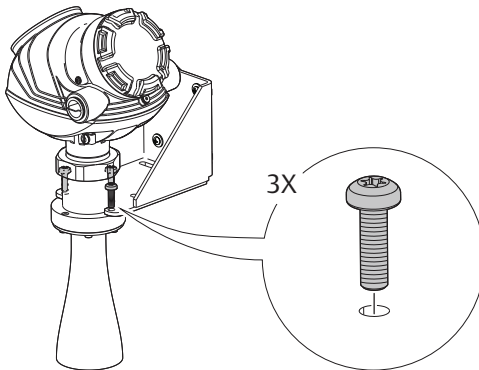

## 4.0 Prepare the electrical connections

### 4.1 Cable selection

Use shielded twisted pair wiring (18-12 AWG).

For the RS-485 bus, use shielded twisted pair wiring, preferably with an impedance of 120 Ω (typically 24 AWG).

### 4.2 Cable gland/conduit

For explosion-proof/ flameproof installations, only use cable glands or conduit entry devices certified explosion-proof or flameproof.

### 4.3 Power supply (Vdc)

Approval type	HART	FOUNDATION Fieldbus	RS-485 with Modbus
None	16 - 42.4	9 - 32	8-30 (max. rating)
Non-sparking/Energy limited	16 - 42.4	9 - 32	N/A
Intrinsically safe	16 - 30	9 - 30	N/A
FISCO	N/A	9 - 17.5	N/A
Explosion-proof/Flameproof	20 - 42.4	16 - 32	8-30 (max. rating)

### 4.4 4-20 mA/HART communication

Figure 1. Wiring Diagram

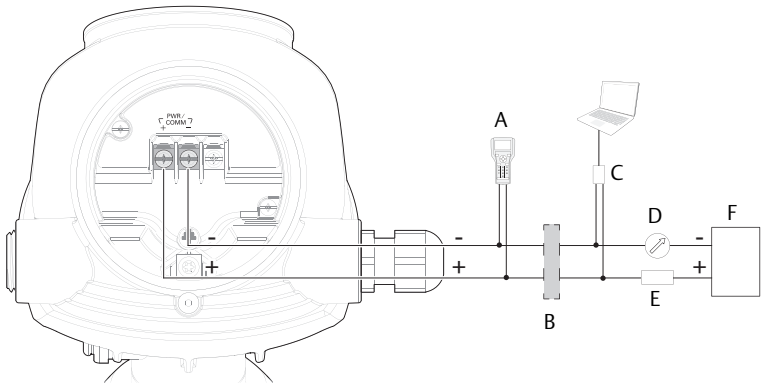

- A. Field Communicator
- B. Approved IS barrier (for Intrinsically Safe installations only)
- C. HART modem
- D. Current meter
- E. Load resistance (≥250 Ω)
- F. Power supply

#### Note

Rosemount 5400 Level Transmitters with Flameproof/Explosion-proof output have a built-in barrier; no external barrier needed.

## Load limitations

For HART communication, a minimum load resistance of 250 Ω is required. Maximum loop resistance is determined by the voltage level of the external power supply, as described by Figure 2.

**Figure 2. Load Limitations**

### Intrinsically safe installations

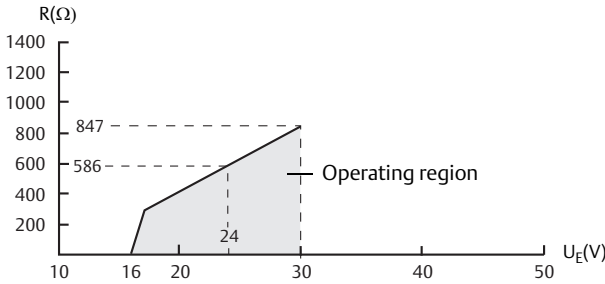

### Non-hazardous and Non-sparking/energy limited installations

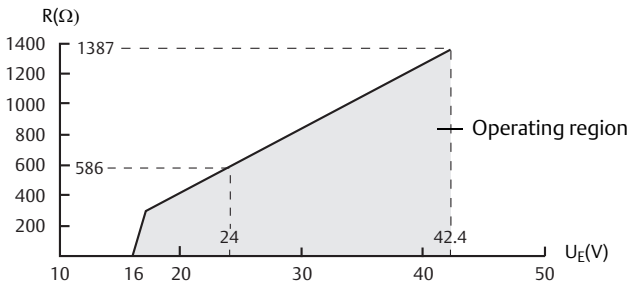

### Explosion-proof/flameproof (Ex d) installations

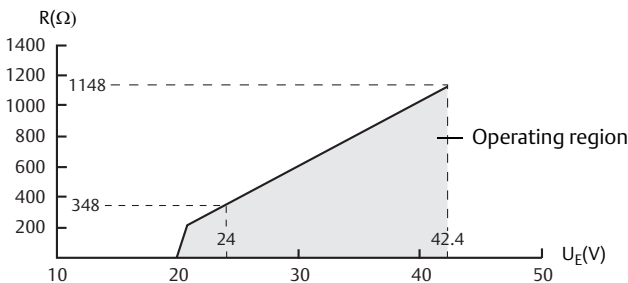

$R(\Omega)$ : Maximum Loop Resistance

$U_E(V)$ : External Power Supply Voltage

### Note

For the Ex d case, the diagram is only valid if the HART load resistance is at the + side and if the - side is grounded, otherwise the load resistance value is limited to 435 Ω.

## 4.5 FOUNDATION Fieldbus

**Figure 3. Wiring Diagram**

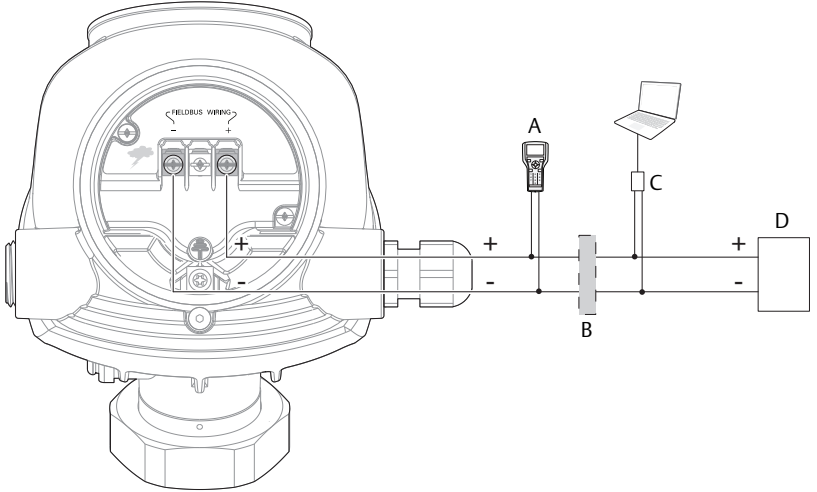

- A. Field Communicator
- B. Approved IS barrier (for Intrinsically Safe installations only)
- C. FOUNDATION Fieldbus modem
- D. Power supply

**Note**

Rosemount 5400 Level Transmitters with Flameproof/Explosion-proof output have a built-in barrier; no external barrier needed.

## 4.6 RS-485 with Modbus communication

See the Rosemount 5300/5400 Series with HART to Modbus Converter [Manual Supplement](#) for details.

### Power consumption

< 0.5 W (with HART address = 1)

< 1.2 W (including four HART slaves)

**Figure 4. Wiring Diagram**

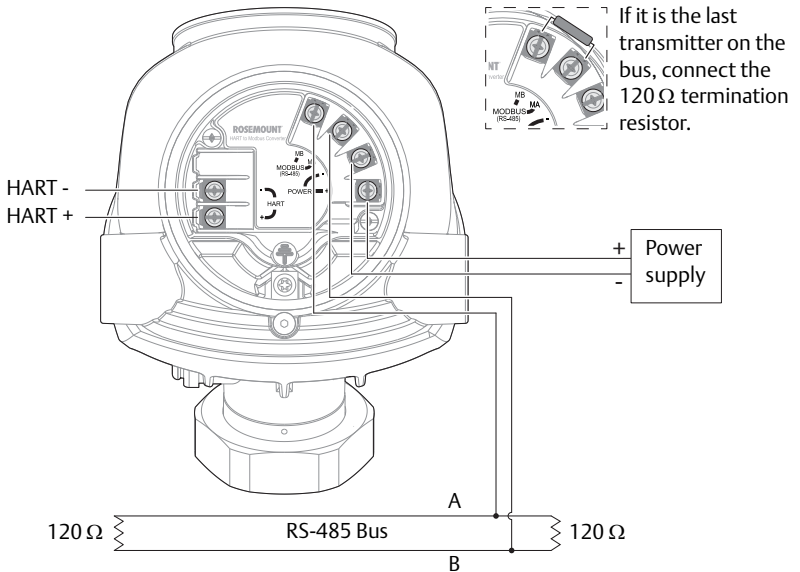

### Note

Rosemount 5400 Level Transmitters with Flameproof/Explosion-proof output have a built-in barrier; no external barrier needed.

## 5.0 Connect wiring and power up

**Step 1:** Verify that the power supply is disconnected

**Step 2:** Remove the cover

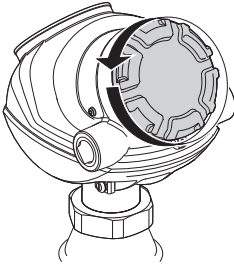

**Step 3:** Remove the plastic plugs

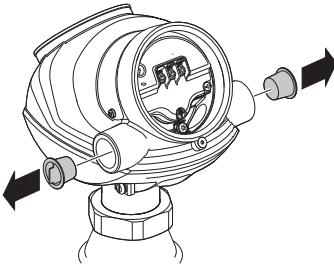

**Step 4:** Pull the cable through the cable gland/conduit

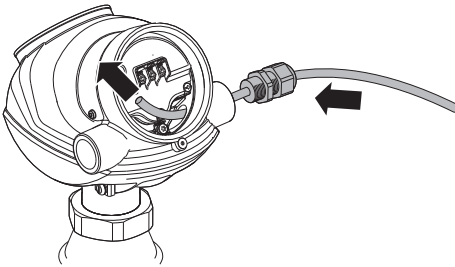

Adapters are required if M20 glands are used.

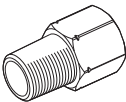

**Step 5:** Connect the cable wires

See the wiring diagrams on [page 11-14](#).

## Step 6: Ensure proper grounding

Make sure grounding is done (including IS ground inside Terminal compartment) according to Hazardous Locations Certifications, national and local electrical codes.

### Transmitter housing grounding

The most effective transmitter housing grounding method is a direct connection to earth ground with minimal ( $< 1 \Omega$ ) impedance. There are two grounding screw connections provided (see Figure 5).

**Figure 5. Ground Screws**

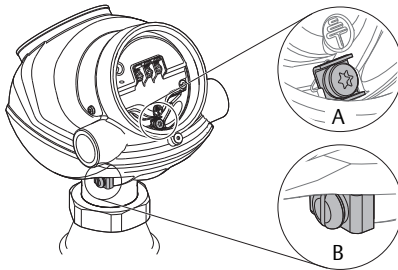

- A. Internal ground screw  
B. External ground screw

### Signal cable shield grounding

Make sure the instrument cable shield is:

- trimmed close and insulated from touching the transmitter housing.
- continuously connected throughout the segment.
- connected to a good earth ground at the power supply end.

**Figure 6. Cable Shield**

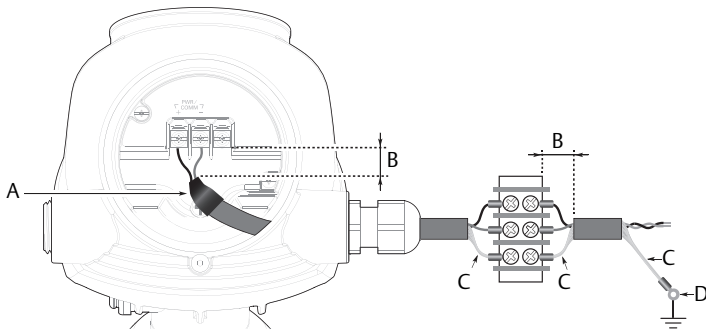

- A. Insulate shield  
B. Minimize distance  
C. Trim shield and insulate  
D. Connect shield back to the power supply ground



### Step 7: Tighten cable glands

Apply PTFE tape or other sealant to the threads.

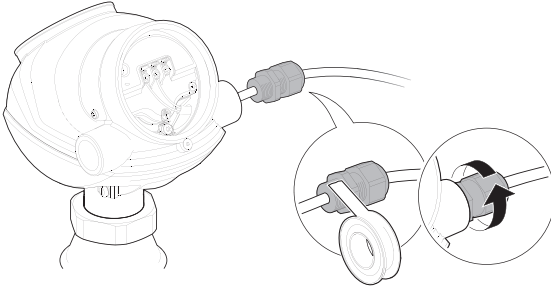

---

#### Note

Arrange the wiring with a drip loop.

---

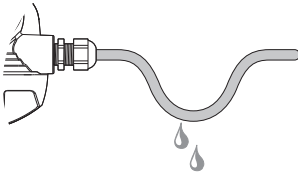

### Step 8: Seal any unused port with enclosed metal plug

Apply PTFE tape or other sealant to the threads.

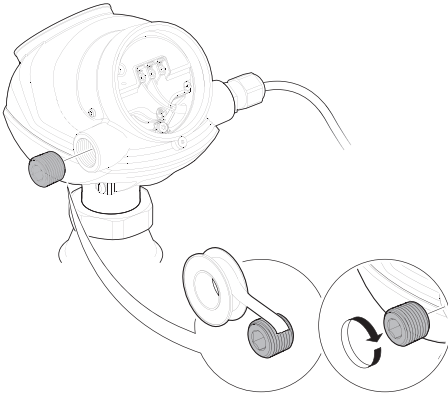

## Step 9: Attach and tighten the cover

1. Verify the cover jam screw is completely threaded into the housing.

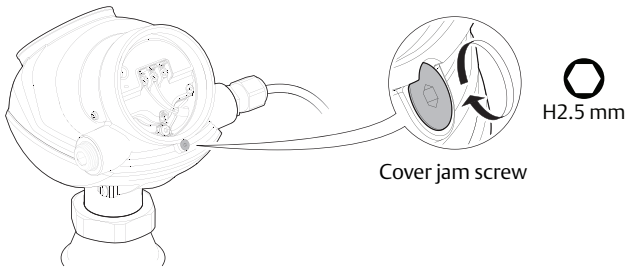

2. Attach and tighten the cover. The cover must be fully engaged to comply with explosion-proof requirements.

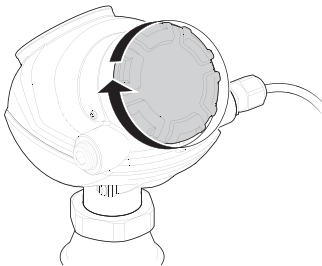

3. Turn the jam screw counterclockwise until it contacts the cover.

⚠ Required for ATEX, IECEx, NEPSI, INMETRO, and TIIS installations only.

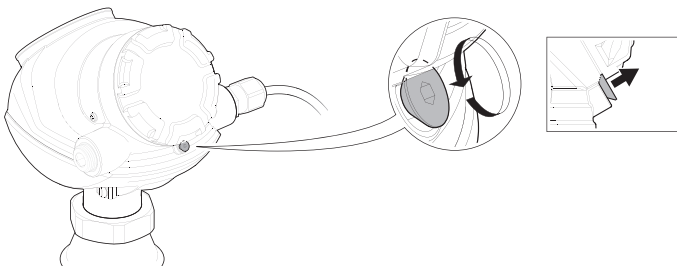

4. Turn the jam screw an additional  $\frac{1}{2}$  turn counterclockwise to secure the cover.

## Step 10: Connect the power supply

## 6.0 Configure

Basic configuration can easily be done either with Rosemount Radar Master, a Field Communicator, the AMS Device Manager, DeltaV™, DTM, or any other DD (Device Description) or DTM compatible host system. For advanced configuration features, Rosemount Radar Master is recommended.

### 6.1 Rosemount Radar Master

1. Start Rosemount Radar Master.
2. Connect to the desired transmitter.
3. In the *Guided Setup* window, select **Run Wizard for guided setup** and follow the instructions.

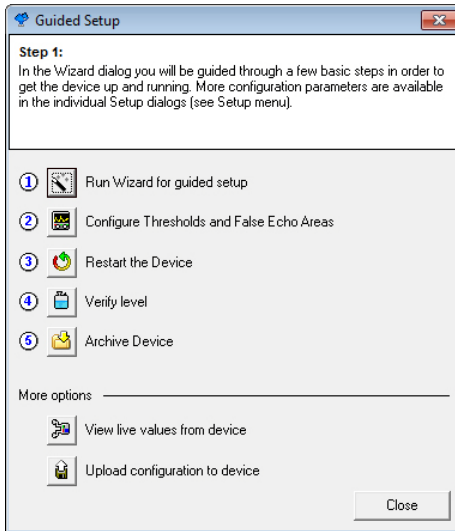

4. In the *Guided Setup* window, continue with steps 2 to 5.
5. Select **View live values from device** to verify the transmitter works correctly.

### 6.2 AMS Device Manager or Field Communicator

#### Step 1: Connect to device

##### AMS Device Manager

1. Start AMS Device Manager.
2. Select **View > Device Connection View**.
3. In the *Device Connection View*, double-click the modem icon.
4. Double-click the device icon.

##### Field Communicator

- Turn on the Field Communicator and connect to the device.

## Step 2: Configure device

### HART Device Revision 2

1. Select **Configure/Setup > Basic Setup**.
2. Configure steps 1-5 in the *Basic Setup*.  
(Variable Mapping, Geometry, Environment, Volume, and Analog Out)
3. Select **Finish**.
4. Run **Measure and Learn**.
5. Select **Restart Device**.

### HART Device Revision 3

1. Select **Configure > Guided Setup**.
2. Select **Level Measurement Setup** and follow the instructions.
3. Run **Verify Level** to check your level measurement.
4. Consider optional setup, such as **Volume** and **Display**.

### FOUNDATION Fieldbus

1. Select **Configure > Guided Setup**.
2. Select **Level Measurement Setup** and follow the instructions.
3. Optional: Select **Volume Calculation Setup**.
4. Run **Measure and Learn**.
5. Select **Restart Measurement**.

**Table 2. FOUNDATION Fieldbus Parameters**

Function	FOUNDATION Fieldbus parameters
Tank Type	TRANSDUCER_1100>GEOM_TANK_TYPE
Tank Bottom Type	TRANSDUCER_1100>GEOM_TANK_BOTTOM_TYPE
Tank Height	TRANSDUCER_1100>GEOM_TANK_HEIGHT
Still-pipe/Bridle Measurement (enable function)	TRANSDUCER_1100>SIGNAL_PROC_CONFIG
Pipe Inner Diameter	TRANSDUCER_1100>ANTENNA_PIPE_DIAM
Process Condition	TRANSDUCER_1100>ENV_ENVIRONMENT
Product Dielectric Constant	TRANSDUCER_1100>ENV_DIELECTR_CONST
Volume Calculation Method	TRANSDUCER_1300>VOLUME_CALC_METHOD
Diameter	TRANSDUCER_1300>VOL_IDEAL_DIAMETER
Length	TRANSDUCER_1300>VOL_IDEAL_LENGTH
Volume Offset	TRANSDUCER_1300>VOL_VOLUME_OFFSET

## 7.0 Safety Instrumented Systems (4-20 mA only)

For Safety Certified installations, refer to the Rosemount 5400 [Reference Manual](#).

## 8.0 Product Certifications

Rev 10.1

### 8.1 European directive information

A copy of the EU Declaration of Conformity can be found at the end of the Quick Start Guide. The most recent revision of the EU Declaration of Conformity can be found at [Emerson.com/Rosemount](http://Emerson.com/Rosemount).

### 8.2 Ordinary location certification

As standard, the transmitter has been examined and tested to determine that the design meets the basic electrical, mechanical, and fire protection requirements by a nationally recognized test laboratory (NRTL) as accredited by the Federal Occupational Safety and Health Administration (OSHA).

### 8.3 Telecommunication compliance

#### FCC

This device complies with Part 15C of the FCC Rules. Operation is subject to the following two conditions: (1) This device may not cause interference, and (2) this device must accept any interference received, including interference that may cause undesired operation.

Certificate: K8C5401 for Model 5401

K8C5402 for Model 5402

#### IC

This device complies with RSS210-5.

This device complies with Industry-Canada license-exempt RSS standard. Operation is subject to the following two conditions: (1) This device may not cause interference, and (2) this device must accept any interference received, including interference that may cause undesired operation.

Le présent appareil est conforme aux CNR d'Industrie Canada applicables aux appareils radio exempts de licence. L'exploitation est autorisée aux deux conditions suivantes: (1) l'appareil ne doit pas produire de brouillage, et (2) l'utilisateur de l'appareil doit accepter tout brouillage radioélectrique subi, même si le brouillage est susceptible d'en compromettre le fonctionnement.

Certificate: 2827A-5401

2827A-5402

#### Radio Equipment Directive (RED)

This device complies with ETSI EN 302 372 and EN 62479. EU directive 2014/53/EU.

### 8.4 Installing equipment in North America

The US National Electrical Code (NEC®) and the Canadian Electrical Code (CEC) permit the use of Division marked equipment in Zones and Zone marked

equipment in Divisions. The markings must be suitable for the area classification, gas, and temperature class. This information is clearly defined in the respective codes.

## 8.5 USA

### E5 Explosionproof (XP), Dust-Ignitionproof (DIP)

Certificate: FM16US0444X

Standards: FM Class 3600 – 2011; FM Class 3610 – 2010; FM Class 3611 – 2004; FM Class 3615 – 2006; FM Class 3810 – 2005; ANSI/ISA 60079-0 – 2013; ANSI/ISA 60079-11 – 2012; ANSI/NEMA® 250 – 2003

Markings: XP CL I, DIV 1, GP B, C, D; DIP CLII/III, DIV 1, GP E, F, G; T4 Ta=60°C and 70°C; Type 4X

#### **Specific Conditions for Safe Use (X):**

1. WARNING – Potential Electrostatic Charging Hazard – The enclosure contains non-metallic material. To prevent the risk for electrostatic sparking the plastic surface should only be cleaned with a damp cloth.
2. WARNING – The apparatus enclosure contains aluminum and is considered to constitute a potential risk of ignition by impact or friction. Care must be taken into account during installation and use to prevent impact or friction.

### I5 Intrinsic Safety (IS), Nonincendive (NI)

Certificate: FM16US0444X

Standards: FM Class 3600 – 2011; FM Class 3610 – 2010; FM Class 3611 – 2004; FM Class 3615 – 2006; FM Class 3810 – 2005; ANSI/ISA 60079-0 – 2013; ANSI/ISA 60079-11 – 2012; ANSI/NEMA 250 – 2003

Markings: IS CL I, II, III, DIV 1, GP A, B, C, D, E, F, G in accordance with control drawing 9150079-905; IS (Entity) CL I, Zone 0, AEx ia IIC T4 in accordance with control drawing 9150079-905, NI CL I, II, DIV 2, GP A, B, C, D, F, G; Suitable for use in CL III DIV 2, indoor and outdoor, T4 Ta=60°C and 70°C; Type 4X

#### **Specific Conditions for Safe Use (X):**

1. WARNING – Potential Electrostatic Charging Hazard – The enclosure contains non-metallic material. To prevent the risk for electrostatic sparking the plastic surface should only be cleaned with a damp cloth.
2. WARNING – The apparatus enclosure contains aluminum and is considered to constitute a potential risk of ignition by impact or friction. Care must be taken into account during installation and use to prevent impact or friction.

	Ui	Ii	Pi	Ci	Li
Entity parameters HART	30 V	130 mA	1 W	7.26 nF	0
Entity parameters Fieldbus	30 V	300 mA	1.3 W	0	0

### IE FISCO

Certificate: FM16US0444X

Standards: FM Class 3600 – 2011; FM Class 3610 – 2010; FM Class 3611 – 2004; FM Class 3615 – 2006; FM Class 3810 – 2005; ANSI/ISA 60079-0 – 2013; ANSI/ISA 60079-11 – 2012; ANSI/NEMA 250 – 2003

Markings: IS CL I, II, III, DIV 1, GP A, B, C, D, E, F, G in accordance with control drawing 9150079-905; IS (Entity) CL I, Zone 0, AEx ia IIC T4 in accordance with control drawing 9150079-905, NI CL I, II, DIV 2, GP A, B, C, D, F, G; Suitable for use in CL III DIV 2, indoor and outdoor, T4 Ta=60°C and 70°C; Type 4X

**Specific Conditions for Safe Use (X):**

1. WARNING – Potential Electrostatic Charging Hazard – The enclosure contains non-metallic material. To prevent the risk for electrostatic sparking the plastic surface should only be cleaned with a damp cloth.
2. WARNING – The apparatus enclosure contains aluminum and is considered to constitute a potential risk of ignition by impact or friction. Care must be taken into account during installation and use to prevent impact or friction.

	Ui	Ii	Pi	Ci	Li
FISCO parameters	17.5 V	380 mA	5.32 W	0	0

## 8.6 Canada

**E6** Explosionproof, Dust-Ignitionproof

Certificate: 1514653

Standards: CSA C22.2 No.0-M91, CSA C22.2 No.25-1966, CSA C22.2 No.30-M1986, CSA C22.2 No.94-M91, CSA C22.2 No.142-M1987, CSA C22.2 157-92, CAN/CSA C22.2 No. 60529:05, ANSI/ISA 12.27.01-2003

Markings: Explosionproof CL I, DIV 1, GP B, C, D; Dust-Ignitionproof CL II, DIV 1 and 2, GP E, F, G and coal dust, CL III, DIV 1, Type 4X/IP66/IP67

**I6** Intrinsically Safe and Non-Incendive Systems

Certificate: 1514653

Standards: CSA C22.2 No.0-M91, CSA C22.2 No.25-1966, CSA C22.2 No.30-M1986, CSA C22.2 No.94-M91, CSA C22.2 No.142-M1987, CSA C22.2 157-92, CAN/CSA C22.2 No. 60529:05, ANSI/ISA 12.27.01-2003

Markings: CL I, DIV 1, GP A, B, C, D, T4 see installation drawing 9150079-906; Non-Incendive Class III, DIV 1, Haz-loc CL I DIV 2, GP A, B, C, D, Maximum Ambient Temperature +60°C for Fieldbus and FISCO and +70 °C for HART, T4, Type 4X/IP66/IP67, Maximum Working Pressure 5000 psi, Dual Seal.

	Ui	Ii	Pi	Ci	Li
Entity parameters HART	30 V	130 mA	1 W	7.26 nF	0
Entity parameters Fieldbus	30 V	300 mA	1.3 W	0	0

**IF** FISCO

Certificate: 1514653

Standards: CSA C22.2 No.0-M91, CSA C22.2 No.25-1966, CSA C22.2 No.30-M1986, CSA C22.2 No.94-M91, CSA C22.2 No.142-M1987, CSA C22.2 157-92, CAN/CSA C22.2 No. 60529:05, ANSI/ISA 12.27.01-2003

Markings: CL I, DIV 1, GP A, B, C, D, T4 see installation drawing 9150079-906; Non-Incendive Class III, DIV 1, Haz-loc CL I DIV 2, GP A, B, C, D, Maximum Ambient Temperature +60°C for Fieldbus and FISCO and +70 °C for HART, T4, Type 4X/IP66/IP67, Maximum Working Pressure 5000 psi, Dual Seal.

	Ui	Ii	Pi	Ci	Li
FISCO parameters	17.5 V	380 mA	5.32 W	0	0

## 8.7 Europe

**E1** ATEX Flameproof

Certificate: Nemko 04ATEX1073X

Standards: EN 60079-0:2012, EN 60079-1:2014, EN 60079-11:2012, EN 60079-26:2015, EN 60079-31:2014

Markings:  II 1/2 G Ex db ia IIC T4 Ga/Gb, (-40°C ≤ Ta ≤ +60°C /+70°C)  
 II 1 D Ex ta IIIC T69°C/T79°C Da, (-40°C ≤ Ta ≤ +60°C /+70°C)  
 Um = 250 V

**Specific Conditions for Safe Use (X):**

1. Potential ignition hazards by impact or friction need to be considered according to EN 60079-0:2012 clause 8.3 (for EPL Ga and EPG Gb), when the transmitter enclosure and antennas exposed to the exterior atmosphere of the tank, is made with light metals containing aluminium or titanium.  
The end user shall determine the suitability with regard to avoid hazards from impact and friction.
2. The antennas for type 5400 are non-conducting and the area of the non-conducting part exceeds the maximum permissible areas for Group IIC, according to EN 60079-0:2012 clause 7.4: 20 cm<sup>2</sup> for EPL Gb and 4 cm<sup>2</sup> for EPL Ga. Therefore, when the antenna is used in a potentially explosive atmosphere, appropriate measures must be taken to prevent electrostatic discharge.
3. Parts of the rod-antennas, for type 5400 are non-conducting material covering metal surfaces. The area of the non-conducting part exceeds the maximum permissible areas for Group III according to EN 60079-0:2012 clause 7.4.3. Therefore, when the antenna is used in a potentially explosive atmosphere group III, EPL Da, appropriate measures must be taken to prevent electrostatic discharge.
4. ½” NPT threads need to be sealed for dust and water ingress protection, IP 66, IP 67 or “Ex t”, EPL Da or Db is required.

**II ATEX Intrinsic Safety**

Certificate: Nemko 04ATEX1073X

Standards: EN 60079-0:2012, EN 60079-1:2014, EN 60079-11:2012, EN 60079-26:2015, EN 60079-31:2014

Markings:  II 1G Ex ia IIC T4 Ga (-50°C ≤ Ta ≤ +60°C /+70°C)  
 II 1/2G Ex ib IIC T4 Ga/Gb (-50°C ≤ Ta ≤ +60°C /+70°C)  
 II 1D Ex ia IIIC T69°C/T79°C Da, (-50°C ≤ Ta ≤ +60°C /+70°C)  
 II 1D Ex ib IIIC T69°C/T79°C Da/Db, (-50°C ≤ Ta ≤ +60°C /+70°C)

**Specific Conditions for Safe Use (X):**

1. The intrinsically safe circuits do not withstand the 500V AC test as specified in EN 60079-11:2012 clause 6.4.13.
2. Potential ignition hazards by impact or friction need to be considered according to EN 60079-0:2012 clause 8.3 (for EPL Ga and EPG Gb), when the transmitter enclosure and antennas exposed to the exterior atmosphere of the tank, is made with light metals containing aluminium or titanium.  
The end user shall determine the suitability with regard to avoid hazards from impact and friction.
3. The antennas for type 5400 are non-conducting and the area of the non-conducting part exceeds the maximum permissible areas for Group IIC, according to EN 60079-0:2012 clause 7.4: 20 cm<sup>2</sup> for EPL Gb and 4 cm<sup>2</sup> for EPL Ga. Therefore, when the antenna is used in a potentially explosive atmosphere, appropriate measures must be taken to prevent electrostatic discharge.
4. Parts of the rod-antennas, for type 5400 are non-conducting material covering metal surfaces. The area of the non-conducting part exceeds the maximum permissible areas for Group III according to EN 60079-0:2012 clause 7.4.3. Therefore, when the antenna is used in a potentially explosive atmosphere group III, EPL Da, appropriate measures must be taken to prevent electrostatic discharge.
5. The Ex ia version of model 5400 may be supplied by an “Ex ib” certified safety barrier. The whole circuit shall then be regarded type “Ex ib”. The preferred type “ia” or “ib”



shall be indicated on the marking label as specified in the instructions for the transmitter. The antenna part, located in the process vessel, is classified EPL Ga and electrically separated from the “Ex ia” or “ib” circuit.

- 6. ½” NPT threads need to be sealed for dust and water ingress protection, IP 66, IP 67 or “Ex t”, EPL Da or Db is required.

	Ui	Ii	Pi	Ci	Li
Entity parameters HART	30 V	130 mA	1 W	7.26 nF	0
Entity parameters Fieldbus	30 V	300 mA	1.5 W	4.95 nF	0

**IA ATEX FISCO**

Certificate: Nemko 04ATEX1073X

Standards: EN 60079-0:2012, EN 60079-1:2014, EN 60079-11:2012, EN 60079-26:2015, EN 60079-31:2014

Markings:  II 1G Ex ia IIC T4 Ga (-50°C ≤ Ta ≤ +60°C)  
 II 1/2G Ex ib IIC T4 Ga/Gb (-50°C ≤ Ta ≤ +60°C)  
 II 1D Ex ia IIIC T69°C Da, (-50°C ≤ Ta ≤ +60°C)  
 II 1D Ex ib IIIC T69°C Da/Db, (-50°C ≤ Ta ≤ +60°C)

**Specific Conditions for Safe Use (X):**

1. The intrinsically safe circuits do not withstand the 500V AC test as specified in EN 60079-11:2012 clause 6.4.13.
2. Potential ignition hazards by impact or friction need to be considered according to EN 60079-0:2012 clause 8.3 (for EPL Ga and EPG Gb), when the transmitter enclosure and antennas exposed to the exterior atmosphere of the tank, is made with light metals containing aluminium or titanium.  
 The end user shall determine the suitability with regard to avoid hazards from impact and friction.
3. The antennas for type 5400 are non-conducting and the area of the non-conducting part exceeds the maximum permissible areas for Group IIC, according to EN 60079-0:2012 clause 7.4: 20 cm<sup>2</sup> for EPL Gb and 4 cm<sup>2</sup> for EPL Ga. Therefore, when the antenna is used in a potentially explosive atmosphere, appropriate measures must be taken to prevent electrostatic discharge.
4. Parts of the rod-antennas, for type 5400 are non-conducting material covering metal surfaces. The area of the non-conducting part exceeds the maximum permissible areas for Group III according to EN 60079-0:2012 clause 7.4.3. Therefore, when the antenna is used in a potentially explosive atmosphere group III, EPL Da, appropriate measures must be taken to prevent electrostatic discharge.
5. The Ex ia version of model 5400 may be supplied by an “Ex ib” certified safety barrier. The whole circuit shall then be regarded type “Ex ib”. The preferred type “ia” or “ib” shall be indicated on the marking label as specified in the instructions for the transmitter. The antenna part, located in the process vessel, is classified EPL Ga and electrically separated from the “Ex ia” or “ib” circuit.
6. ½” NPT threads need to be sealed for dust and water ingress protection, IP 66, IP 67 or “Ex t”, EPL Da or Db is required.

	Ui	Ii	Pi	Ci	Li
FISCO parameters	17.5 V	380 mA	5.32 W	4.95 nF	<1 μH

**N1** ATEX Type N

Certificate: Nemko 10ATEX1072X

Standards: EN 60079-0:2012, EN 60079-11:2012, EN 60079-15:2010, EN 60079-21:2013

Markings:  II 3G Ex nA IIC T4 Gc (-50°C ≤ Ta ≤ +60°C / +70°C)

II 3G Ex ic IIC T4 Gc (-50°C ≤ Ta ≤ +60°C / +70°C)

II 3D Ex tc IIIC T69°C/T79°C Dc (-50°C ≤ Ta ≤ +60°C / +70°C)

**Specific Conditions for Safe Use (X):**

1. The transmitter circuits does not withstand 500V AC dielectric strength test according to EN 60079-11 clause 6.3.13 due to earth connected transient suppressing devices. Appropriate measures have to be considered by installation.
2. The antennas for type 5400, are non-conducting and the area of the non-conducting part exceeds the maximum permissible areas for Group IIC and according to EN 60079-0:2012 clause 7.4: 20 cm<sup>2</sup> / 80 cm<sup>2</sup> for EPL Gc. Therefore, when the antenna is used in a potentially explosive atmosphere, appropriate measures must be taken to prevent electrostatic discharge.

	Ui	Ii	Pi	Ci	Li
Safety parameters HART	42.4 V	23 mA	1 W	7.25 nF	Negligible
Safety parameters Fieldbus	32 V	21 mA	0.7 W	4.95 nF	Negligible

**8.8 International****E7** IECEx Flameproof

Certificate: IECEx NEM 06.0001X

Standards: IEC 60079-0:2011, IEC 60079-1:2014-06, IEC 60079-11:2011;

IEC 60079-26:2014, IEC 60079-31:2013

Markings: Ex db ia IIC T4 Ga/Gb (-40°C ≤ Ta ≤ +60°C / +70°C),

Ex ta IIIC T69°C/T79°C Da (-40°C ≤ Ta ≤ +60°C / +70°C)

Um=250 VAC, IP66/IP67

**Specific Conditions for Safe Use (X):**

1. The intrinsically safe circuits do not withstand the 500V AC test as specified in EN 60079-11:2012 clause 6.4.13.
2. Potential ignition hazards by impact or friction need to be considered according to EN 60079-0:2012 clause 8.3 (for EPL Ga and EPG Gb), when the transmitter enclosure and antennas exposed to the exterior atmosphere of the tank, is made with light metals containing aluminium or titanium.  
The end user shall determine the suitability with regard to avoid hazards from impact and friction.
3. The antennas for type 5400 are non-conducting and the area of the non-conducting part exceeds the maximum permissible areas for Group IIC, according to EN 60079-0:2012 clause 7.4: 20 cm<sup>2</sup> for EPL Gb and 4 cm<sup>2</sup> for EPL Ga. Therefore, when the antenna is used in a potentially explosive atmosphere, appropriate measures must be taken to prevent electrostatic discharge.
4. Parts of the rod-antennas, for type 5400 are non-conducting material covering metal surfaces. The area of the non-conducting part exceeds the maximum permissible areas for Group III according to EN 60079-0:2012 clause 7.4.3. Therefore, when the antenna is used in a potentially explosive atmosphere group III, EPL Da, appropriate measures must be taken to prevent electrostatic discharge.
5. The Ex ia version of model 5400 may be supplied by an “Ex ib” certified safety barrier. The whole circuit shall then be regarded type “Ex ib”. The preferred type “ia” or “ib” shall be indicated on the marking label as specified in the instructions for the transmitter. The antenna part, located in the process vessel, is classified EPL Ga and

- electrically separated from the “Ex ia” or” ib” circuit.
6. 1/2” NPT threads need to e sealed for dust and water ingress protection, IP 66, IP 67 or “Ex t”, EPL Da or Db is required.

**17 IECEx Intrinsic Safety**

Certificate: IECEx NEM 06.0001X

Standards: IEC 60079-0:2011, IEC 60079-1:2014-06, IEC 60079-11:2011;  
IEC 60079-26:2014, IEC 60079-31:2013

Markings: Ex ia IIC T4 Ga (-50°C ≤ Ta ≤ +60°C /+70°C)  
Ex ib IIC T4 Ga/Gb (-50°C ≤ Ta ≤ +60°C /+70°C)  
Ex ia IIIC T69°C/79°C Da (-50°C ≤ Ta ≤ +60°C /+70°C)  
Ex ib IIIC T69°C/79°C Da/Db (-50°C ≤ Ta ≤ +60°C /+70°C)

**Specific Conditions for Safe Use (X):**

1. The intrinsically safe circuits do not withstand the 500V AC test as specified in EN 60079-11:2012 clause 6.4.13.
2. Potential ignition hazards by impact or friction need to be considered according to EN 60079-0:2012 clause 8.3 (for EPL Ga and EPG Gb), when the transmitter enclosure and antennas exposed to the exterior atmosphere of the tank, is made with light metals containing aluminium or titanium.  
The end user shall determine the suitability with regard to avoid hazards from impact and friction.
3. The antennas for type 5400 are non-conducting and the area of the non-conducting part exceeds the maximum permissible areas for Group IIC, according to EN 60079-0:2012 clause 7.4: 20 cm<sup>2</sup> for EPL Gb and 4 cm<sup>2</sup> for EPL Ga. Therefore, when the antenna is used in a potentially explosive atmosphere, appropriate measures must be taken to prevent electrostatic discharge.
4. Parts of the rod-antennas, for type 5400 are non-conducting material covering metal surfaces. The area of the non-conducting part exceeds the maximum permissible areas for Group III according to EN 60079-0:2012 clause 7.4.3 Therefore, when the antenna is used in a potentially explosive atmosphere group III, EPL Da, appropriate measures must be taken to prevent electrostatic discharge.
5. The Ex ia version of model 5400 may be supplied by an “Ex ib” certified safety barrier. The whole circuit shall then be regarded type “Ex ib”. The preferred type “ia” or “ib” shall be indicated on the marking label as specified in the instructions for the transmitter. The antenna part, located in the process vessel, is classified EPL Ga and electrically separated from the “Ex ia” or” ib” circuit.
6. 1/2” NPT threads need to e sealed for dust and water ingress protection, IP 66, IP 67 or “Ex t”, EPL Da or Db is required.

	Ui	Ii	Pi	Ci	Li
Entity parameters HART	30 V	130 mA	1 W	7.26 nF	0 mH
Entity parameters Fieldbus	30 V	300 mA	1.5 W	4.95 nF	0 mH

**IG** IECEx FISCO

Certificate: IECEx NEM 06.0001X

Standards: IEC 60079-0:2011, IEC 60079-1:2014-06, IEC 60079-11:2011;  
IEC 60079-26:2014, IEC 60079-31:2013Markings: Ex ia IIC T4 Ga (-50°C ≤ Ta ≤ +60°C)  
Ex ib IIC T4 Ga/Gb (-50°C ≤ Ta ≤ +60°C)  
Ex ia IIIC T69°C/79°C Da (-50°C ≤ Ta ≤ +60°C)  
Ex ib IIIC T69°C/79°C Da/Db (-50°C ≤ Ta ≤ +60°C)**Specific Conditions for Safe Use (X):**

1. The intrinsically safe circuits do not withstand the 500V AC test as specified in EN 60079-11:2012 clause 6.4.13.
2. Potential ignition hazards by impact or friction need to be considered according to EN 60079-0:2012 clause 8.3 (for EPL Ga and EPG Gb), when the transmitter enclosure and antennas exposed to the exterior atmosphere of the tank, is made with light metals containing aluminium or titanium.  
The end user shall determine the suitability with regard to avoid hazards from impact and friction.
3. The antennas for type 5400 are non-conducting and the area of the non-conducting part exceeds the maximum permissible areas for Group IIC, according to EN 60079-0:2012 clause 7.4: 20 cm<sup>2</sup> for EPL Gb and 4 cm<sup>2</sup> for EPL Ga. Therefore, when the antenna is used in a potentially explosive atmosphere, appropriate measures must be taken to prevent electrostatic discharge.
4. Parts of the rod-antennas, for type 5400 are non-conducting material covering metal surfaces. The area of the non-conducting part exceeds the maximum permissible areas for Group III according to EN 60079-0:2012 clause 7.4.3. Therefore, when the antenna is used in a potentially explosive atmosphere group III, EPL Da, appropriate measures must be taken to prevent electrostatic discharge.
5. The Ex ia version of model 5400 may be supplied by an "Ex ib" certified safety barrier. The whole circuit shall then be regarded type "Ex ib". The preferred type "ia" or "ib" shall be indicated on the marking label as specified in the instructions for the transmitter. The antenna part, located in the process vessel, is classified EPL Ga and electrically separated from the "Ex ia" or "ib" circuit.
6. ½" NPT threads need to be sealed for dust and water ingress protection, IP 66, IP 67 or "Ex t", EPL Da or Db is required.

	Ui	Ii	Pi	Ci	Li
FISCO parameters	17.5 V	380 mA	5.32 W	4.95 nF	<1 μH

**N7** IECEx Type N

Certificate: IECEx BAS 10.0005X

Standards: IEC 60079-0:2011, IEC 60079-11:2011, IEC 60079-15:2010,  
IEC 60079-31:2010Markings: Ex nA IIC T4 Gc (-50°C ≤ Ta ≤ +60°C /+70°C)  
Ex ic IIC T4 Gc (-50°C ≤ Ta ≤ +60°C /+70°C)  
Ex tc IIIC T69°C /T79°C (-50°C ≤ Ta ≤ +60°C /+70°C)**Specific Conditions for Safe Use (X):**

1. The transmitter circuits does not withstand 500V AC dielectric strength test according to EN 60079-11 clause 6.3.13 due to earth connected transient suppressing devices. Appropriate measures have to be considered by installation.

	Ui	Ii	Pi	Ci	Li
Safety parameters HART	42.4 V	23 mA	1 W	7.25 nF	Negligible
Safety parameters Fieldbus	32 V	21 mA	0.7 W	4.95 nF	Negligible

## 8.9 Brazil

### E2 INMETRO Flameproof

Certificate: UL-BR 17.0188X

Standards: ABNT NBR IEC 60079-0:2011, ABNT NBR IEC 60079-1:2009 + Errata 1:2011, ABNT NBR IEC 60079-11:2009, ABNT NBR IEC 60079-26:2008 + Errata 1:2009, ABNT NBR IEC 60079-31:2011

Markings: Ex db ia IIC T4 Ga/Gb (-40°C ≤ T<sub>amb</sub> ≤ +60°C / +70°C)  
 Ex ta IIIC T69°C/T79°C Da (-40°C ≤ T<sub>amb</sub> ≤ +60°C / +70°C)  
 IP 66/IP67

**Specific Conditions for Safe Use (X):**

1. See certificate for Specific Conditions.

### I2 INMETRO Intrinsic Safety

Certificate: UL-BR 17.0188X

Standards: ABNT NBR IEC 60079-0:2011, ABNT NBR IEC 60079-11:2009, ABNT NBR IEC 60079-26:2008 + Errata 1:2009, ABNT NBR IEC 60079-31:2011

Markings: Ex ia IIC T4 Ga (-50°C ≤ T<sub>amb</sub> ≤ +60°C / +70°C)  
 Ex ib IIC T4 Ga/Gb (-50°C ≤ T<sub>amb</sub> ≤ +60°C / +70°C)  
 Ex ia IIIC T69°C/T79°C Da, Ex ib IIIC T69°C/T79°C Da/Db

**Specific Conditions for Safe Use (X):**

1. See certificate for Specific Conditions.

	Ui	Ii	Pi	Ci	Li
Entity parameters HART	30 V	130 mA	1 W	7.26 nF	0 μH
Entity parameters Fieldbus	30 V	300 mA	1.5 W	4.95 nF	0 μH

### IB INMETRO FISCO

Certificate: UL-BR 17.0188X

Standards: ABNT NBR IEC 60079-0:2011, ABNT NBR IEC 60079-11:2009, ABNT NBR IEC 60079-26:2008 + Errata 1:2009, ABNT NBR IEC 60079-31:2011

Markings: Ex ia IIC T4 Ga (-50°C ≤ T<sub>amb</sub> ≤ +60°C)  
 Ex ib IIC T4 Ga/Gb (-50°C ≤ T<sub>amb</sub> ≤ +60°C)  
 Ex ia IIIC T69°C Da, Ex ia/ib IIIC T69°C Da/Db

**Specific Conditions for Safe Use (X):**

1. See certificate for Specific Conditions.

	Ui	Ii	Pi	Ci	Li
FISCO parameters	17.5 V	380 mA	5.32 W	4.95 nF	<1 μH

## 8.10 China

### E3 China Flameproof

Certificate: GYJ16.1094X

Standards: GB3836.1/2/4/20-2010, GB12476.1/5-2013, GB12476.4-2010

Markings: Ex d ia IIC T4 Ga/Gb  
Ex tD A20 IP66/67 T69°C / T79°C

#### **Specific Conditions for Safe Use (X):**

1. See certificate for Specific Conditions.

### I3 China Intrinsic Safety

Certificate: GYJ16.1094X

Standards: GB3836.1/2/4/20-2010, GB12476.1/5-2013, GB12476.4-2010

Markings: Ex ia IIC T4 Ga  
Ex ib IIC T4 Ga/Gb  
Ex iaD 20 T69°C / T79°C  
Ex ibD 20/21 T69°C / T79°C

#### **Specific Conditions for Safe Use (X):**

1. See certificate for Specific Conditions.

	Ui	Ii	Pi	Ci	Li
Entity parameters HART	30 V	130 mA	1 W	7.26 nF	0 mH
Entity parameters Fieldbus	30 V	300 mA	1.5 W	4.95 nF	0 mH

### IC China FISCO

Certificate: GYJ16.1094X

Standards: GB3836.1/2/4/20-2010, GB12476.1/5-2013, GB12476.4-2010

Markings: Ex ia IIC T4 Ga  
Ex ib IIC T4 Ga/Gb  
Ex iaD 20 T69°C  
Ex ibD 20/21 T69°C

#### **Specific Conditions for Safe Use (X):**

1. See certificate for Specific Conditions.

	Ui	Ii	Pi	Ci	Li
FISCO parameters	17.5 V	380 mA	5.32 W	4.95 nF	<0.001 mH

### N3 China Type N

Certificate: CNEx13.1930X

Standards: GB 3836.1-2010, GB 3836.8-2003

Markings: Ex nA nL IIC T4 Gc  
Ex nA IIC T4 Gc  
Ex nL IIC T4 Gc  
IP66/IP67

#### **Specific Conditions for Safe Use (X):**

1. See certificate for Specific Conditions.

	Ui	Ii	Pi	Ci	Li
Maximum input parameters for Ex nL HART	42.4 V DC	23 mA	1 W	7.25 nF	0
Maximum input parameters for Ex nL Fieldbus	32 V DC	21 mA	0.7 W	4.95 nF	0

## 8.11 Technical Regulations Customs Union (EAC)

- EM** Technical Regulations Customs Union (EAC) Flameproof  
 Certificate: RU C-SE.AA87.B.00108  
 Markings: Ga/Gb Ex d ia IIC T4 X, (-40°C ≤ Ta ≤ +60°C/+70°C)

**Specific Conditions for Safe Use (X):**

1. See certificate for Specific Conditions.

- IM** Technical Regulations Customs Union (EAC) Intrinsic Safety  
 Certificate: RU C-SE.AA87.B.00108  
 Markings: 0Ex ia IIC T4 Ga X, (-50°C ≤ Ta ≤ +60°C/+70°C)  
 Ga/Gb Ex ib IIC T4 X, (-50°C ≤ Ta ≤ +60°C/+70°C)

**Specific Conditions for Safe Use (X):**

1. See certificate for Specific Conditions.

	Ui	Ii	Pi	Ci	Li
Entity parameters HART	30 V	130 mA	1 W	7.26 nF	0 mH
Entity parameters Fieldbus	30 V	300 mA	1.5 W	4.95 nF	0 mH

## 8.12 Japan

- E4** Flameproof 5401 HART Rod  
 Certificate: TC221112X  
 Markings: Ex d [ia Ga] IIC T4 Gb

**Specific Conditions for Safe Use (X):**

1. See certificate for Specific Conditions.

- E4** Flameproof 5401 HART Cone  
 Certificate: TC22111X  
 Markings: Ex d [ia Ga] IIC T4 Gb

**Specific Conditions for Safe Use (X):**

1. See certificate for Specific Conditions.

- E4** Flameproof 5402 HART  
 Certificate: TC22113X  
 Markings: Ex d [ia Ga] IIC T4 Gb

**Specific Conditions for Safe Use (X):**

1. See certificate for Specific Conditions.

- E4** Flameproof 5401 Fieldbus Rod  
 Certificate: TC 20244  
 Markings: Ex d [ia] IIC T4 X

**Specific Conditions for Safe Use (X):**

1. See certificate for Specific Conditions.

- E4** Flameproof 5401 Fieldbus Cone  
 Certificate: TC 20245  
 Markings: Ex d [ia] IIC T4 X

**Specific Conditions for Safe Use (X):**

1. See certificate for Specific Conditions.

- E4** Flameproof 5402 Fieldbus  
 Certificate: TC 20246  
 Markings: Ex d [ia] IIC T4 X

**Specific Conditions for Safe Use (X):**

1. See certificate for Specific Conditions.

## 8.13 India

Flameproof

Certificate: P392482/1

Markings: Ex db ia T4 Ga/Gb  
Ex ia T4 Ga

**Specific Conditions for Safe Use (X):**

1. See certificate for Specific Conditions.

## 8.14 Ukraine

Flameproof, Intrinsically Safe

Certificate: UA.TR.047.C.0352-13

Markings: 1 Ex de IIC T4X  
1 Ex de ib ia IIC T4 X  
1 Ex de ia IIC T6 X

**Specific Conditions for Safe Use (X):**

1. See certificate for Specific Conditions.

## 8.15 Uzbekistan

Safety (import)

Certificate: UZ.SMT.01.342.2017121

## 8.16 Republic of Korea

**EP** Flameproof HART

Certificate: 13-KB4BO-0018X

Markings: Ex ia/d ia IIC T4 Ga/Gb

**Specific Conditions for Safe Use (X):**

1. See certificate for Specific Conditions.

**EP** Flameproof Fieldbus

Certificate: 13-KB4BO-0017X

Markings: Ex ia/d ia IIC T4 Ga/Gb

**Specific Conditions for Safe Use (X):**

1. See certificate for Specific Conditions.

## 8.17 Combinations

**KG** Combination of E1, E5 and E6

**KH** Combination of IA, IE and IF

**KI** Combination of I1, I5 and I6

## 8.18 Additional certifications

**SBS** American Bureau of Shipping (ABS) Type Approval

Certificate: 15-LD1345569-PDA

Intended Use: Use on ABS Classed Vessels and Offshore Facilities in accordance with the listed ABS rules and International Standards.

**SBV** Bureau Veritas (BV) Type Approval

Certificate: 22379\_B0 BV



Requirements: Bureau Veritas Rules for the Classification of Steel Ships  
 Application: Approval valid for the ships intended to be granted with the following additional class notations: AUT-UMS, AUT-CCS, AUT-PORT and AUT-IMS.

**SDN** Det Norske Veritas (DNV) Type Approval

Certificate: A-14117

Intended Use: Det Norske Veritas' Rules for Classification of Ships, High Speed and Light Craft and Det Norske Veritas' Offshore Standards.

Application:

Location classes	
Temperature	D
Humidity	B
Vibration	A
EMC	B
Enclosure	C

**SLL** Lloyds Register (LR) Type Approval

Certificate: 15/20045

Application: Marine applications for use in environmental categories ENV1, ENV2, ENV3 and ENV5.

**U1** Overfill prevention

Certificate: Z-65.16-475

Application: TÜV tested and approved by DIBt for overfill prevention according to the German WHG regulations.

## 8.19 Pattern approval

GOST Belarus

Certificate: RB-03 07 2765 10

GOST Kazakhstan

Certificate: KZ.02.02.03473-2013

GOST Russia

Certificate: SE.C.29.010.A

GOST Uzbekistan

Certificate: 02.2977-14

China Pattern Approval

Certificate: CPA 2012-L136

## 8.20 Conduit plugs and adapters

IECEX Flameproof and Increased Safety

Certificate: IECEX FMG 13.0032X

Standards: IEC60079-0:2011, IEC60079-1:2007, IEC60079-7:2006-2007

Markings: Ex de IIC Gb

ATEX Flameproof and Increased Safety

Certificate: FM13ATEX0076X

Standards: EN60079-0:2012, EN60079-1:2007, IEC60079-7:2007

Markings:  II 2 G Ex de IIC Gb

### Conduit Plug Thread Sizes

Thread	Identification mark
M20 x 1.5	M20
½ - 14 NPT	½ NPT

### Thread Adapter Thread Sizes

Male thread	Identification mark
M20 x 1.5 – 6g	M20
½- 14 NPT	½ - 14 NPT
¾ - 14 NPT	¾- 14 NPT
Female thread	Identification mark
M20 x 1.5 – 6H	M20
½ - 14 NPT	½ - 14 NPT
G1/2	G1/2

### Specific Conditions for Safe Use (X):

1. When the thread adapter or blanking plug is used with an enclosure in type of protection increased safety “e” the entry thread shall be suitably sealed in order to maintain the ingress protection rating (IP) of the enclosure. See certificate for Specific Conditions.
2. The blanking plug shall not be used with an adapter.
3. Blanking Plug and Threaded Adapter shall be either NPT or Metric thread forms. G½ thread forms are only acceptable for existing (legacy) equipment installations.

## 8.21 EU Declaration of Conformity

Figure 7. Rosemount 5400 EU Declaration of Conformity

	
<h3>EU Declaration of Conformity</h3>	
<p><b>No: 5400</b></p>	
<p>We,</p>	
<p><b>Rosemount Tank Radar AB</b>  <b>Layoutvägen 1</b>  <b>S-435 33 MÖLNLYCKE</b>  <b>Sweden</b></p>	
<p>declare under our sole responsibility that the product,</p>	
<p><b>Rosemount 5400 Series Radar Level Transmitter</b></p>	
<p>manufactured by,</p>	
<p><b>Rosemount Tank Radar AB</b>  <b>Layoutvägen 1</b>  <b>S-435 33 MÖLNLYCKE</b>  <b>Sweden</b></p>	
<p>is in conformity with the provisions of the European Community Directives, including the latest amendments, as shown in the attached schedule.</p>	
<p>Presumption of conformity is based on the application of the harmonized standards, normative documents or other documents and, when applicable or required, a European Community notified body certification, as shown in attached schedule.</p>	
	<p>Manager Product Approvals</p>
<p>_____ (signature)</p>	<p>_____ (function name - printed)</p>
<p>Dajana Prastalo</p>	<p>2017-05-17</p>
<p>_____ (name - printed)</p>	<p>_____ (date of issue)</p>



**Schedule  
No: 5400**



**EMC Directive (2014/30/EU)**

EN 61326-1:2013

**ATEX Directive (2014/34/EU)**

**Nemko 04ATEX1073X**

**Intrinsic Safety (Hart@ 4-20mA):**

Equipment Group II, Category 1G, Ex ia IIC T4 Ga  
 Equipment Group II, Category 1/2 G, Ex ib IIC T4 Ga/Gb  
 Equipment Group II, Category 1D, Ex ia IIIC T79° Da  
 Equipment Group II, Category 1/2 D, Ex ib IIIC T79°C Da/Db

**Intrinsic Safety (Foundation ® Fieldbus):**

Equipment Group II, Category 1G, Ex ia IIC T4 Ga  
 Equipment Group II, Category 1/2 G, Ex ib IIC T4 Ga/Gb  
 Equipment Group II, Category 1D, Ex ia IIIC T69° Da  
 Equipment Group II, Category 1/2 D, Ex ib IIC T69°C Da/Db

**Intrinsic Safety (Foundation ® Fieldbus FISCO):**

Equipment Group II, Category 1G, Ex ia IIC T4 Ga  
 Equipment Group II, Category 1/2G, Ex ia IIC T4 Ga/Gb  
 Equipment Group II, Category 1D, Ex ia IIIC T69° Da  
 Equipment Group II, Category 1/2D, Ex ib IIIC T69° Da/Db

**Flameproof (Hart@ 4-20mA, Modbus RS-485):**

Equipment Group II, Category 1/2G, Ex db ia IIC T4 Ga/Gb  
 Equipment Group II, Category 1D, Ex ta IIIC T79° Da

**Flameproof (Foundation ® Fieldbus):**

Equipment Group II, Category 1/2G, Ex db ia IIC T4 Ga/Gb  
 Equipment Group II, Category 1D, Ex ta IIIC T69° Da

EN 60079-0:2012; EN 60079-1:2014; EN 60079-11:2012; EN 60079-26:2015;  
 EN 60079-31:2014



**Schedule  
No: 5400**

---

**Nemko 10ATEX1072X**

**Type of protection N, Non-sparking (Hart@ 4-20mA):**

Equipment Group II, Category 3G, Ex nA IIC T4 Gc  
Equipment Group II, Category 3D, Ex tc IIIC T79° Dc

**Type of protection N, Non-sparking (Foundation ® Fieldbus):**

Equipment Group II, Category 3G, Ex nA IIC T4 Gc  
Equipment Group II, Category 3D, Ex tc IIIC T69° Dc

**Intrinsic Safety (Hart@ 4-20mA):**

Equipment Group II, Category 3G, Ex ic IIC T4 Gc  
Equipment Group II, Category 3D, Ex tc IIIC T79° Dc

**Intrinsic Safety (Foundation ® Fieldbus):**

Equipment Group II, Category 3G, Ex ic IIC T4 Gc  
Equipment Group II, Category 3D, Ex tc IIIC T69° Dc

EN60079-0:2012; EN60079-11:2012; EN60079-15:2010; EN60079-31:2013

---

**Low Voltage Directive (2014/35/EU)**

IEC 61010-1:2010

---

**RE Directive (2014/53/EU)**

ETSI EN 302372:2016; EN 62479:2010



**Schedule  
No: 5400**



---

**ATEX Notified Body for EU Type Examination Certificates and Type Examination Certificates**

**Nemko AS** [Notified Body Number: 0470]  
P.O.Box 73 Blindern  
0314 OSLO  
Norway

---

**ATEX Notified Body for Quality Assurance**

**DNV Nemko Presafe AS** [Notified Body Number: 2460]  
Veritasveien 1  
1322 HØVIK  
Norway

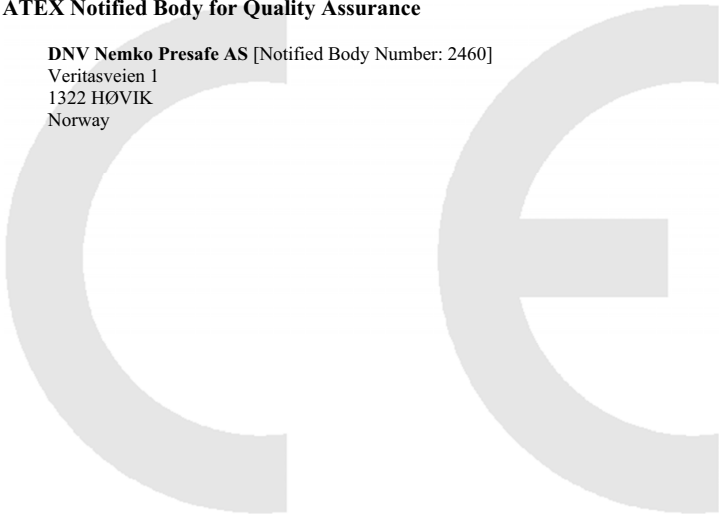

**Figure 8. 9150079-905 - System Control Drawing for Hazardous Location Installation of Intrinsically Safe FM Approved Apparatus**

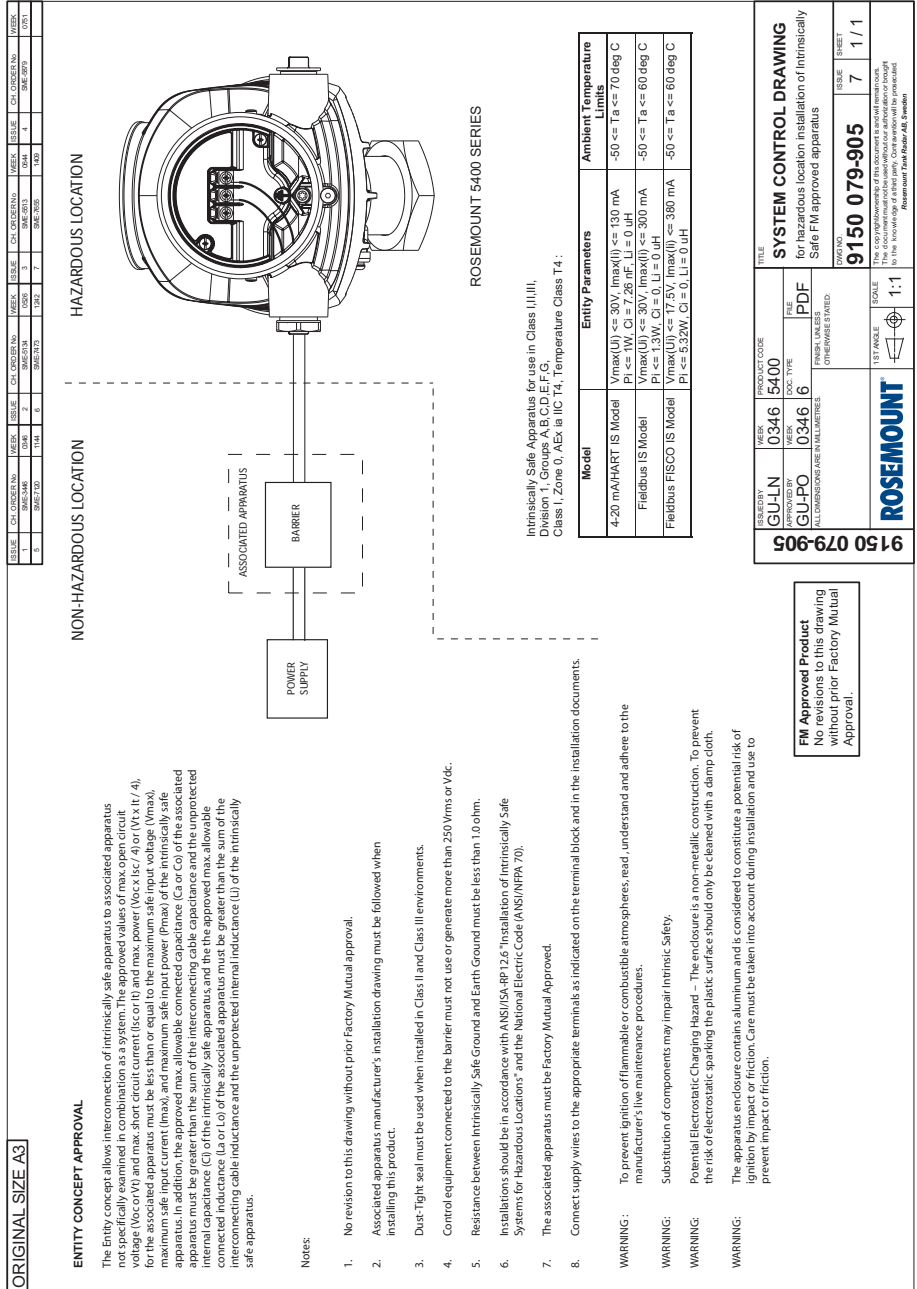
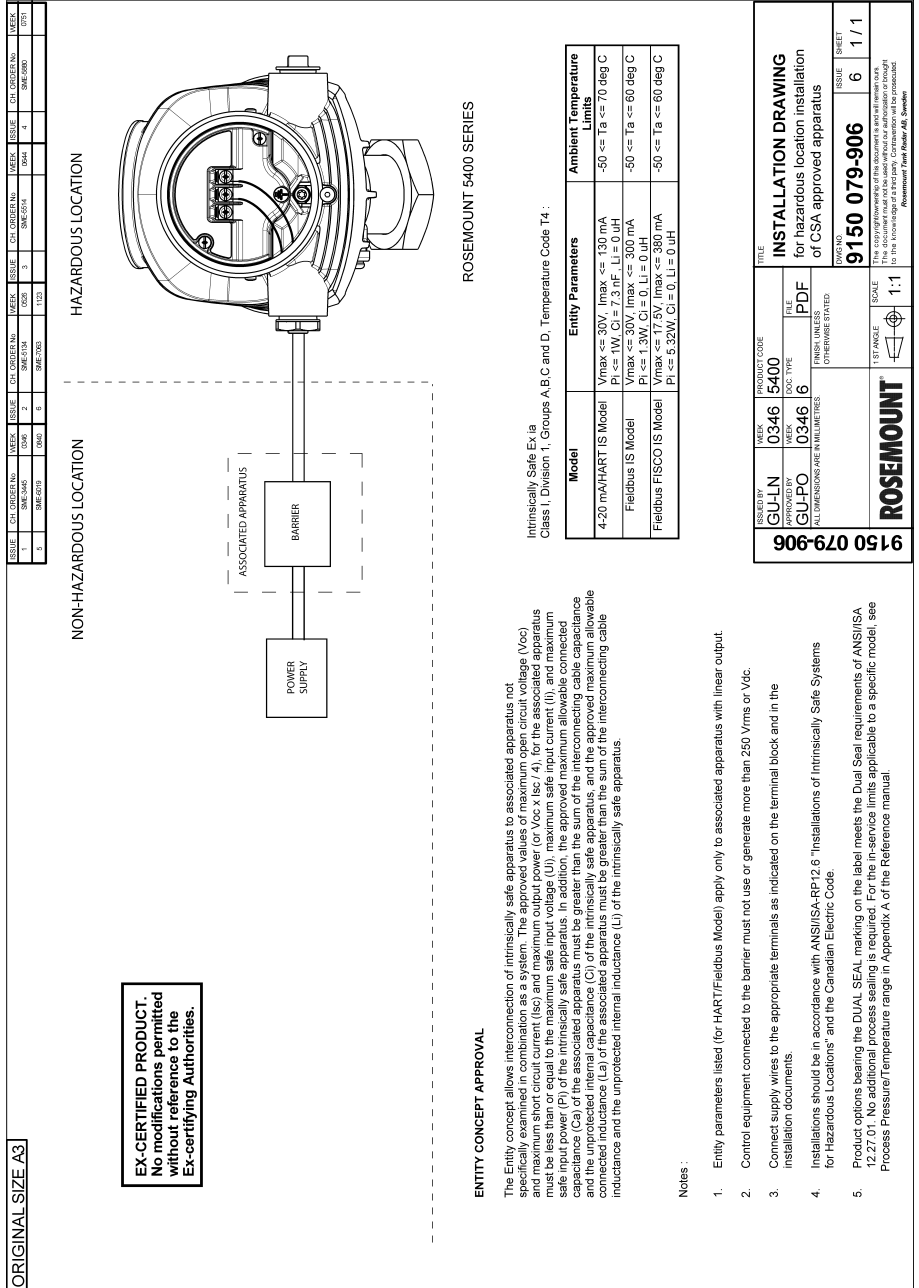

Figure 9. 9150079-906 - System Control Drawing for Hazardous Location Installation of CSA Approved Apparatus



**ENTITY CONCEPT APPROVAL**

The Entity concept allows interconnection of intrinsically safe apparatus to associated apparatus not specifically examined in combination as a system. The approved values of maximum open circuit voltage (Voc) and maximum short circuit current (Isc) and maximum output power (or Voc x Isc / 4), for the associated apparatus must be less than or equal to the maximum safe input voltage (U0), maximum safe input current (I0), and maximum safe input power (P0) of the intrinsically safe apparatus. The sum of the internal capacitance (Ci) and maximum safe capacitance (Ca) of the associated apparatus must be greater than the sum of the interconnecting cable capacitance and the unprotected internal capacitance (Ci) of the intrinsically safe apparatus, and the approved maximum allowable connected inductance (La) of the associated apparatus must be greater than the sum of the interconnecting cable inductance and the unprotected internal inductance (Li) of the intrinsically safe apparatus.

**Notes :**

1. Entity parameters listed (for HART/Fieldbus Model) apply only to associated apparatus with linear output.
2. Control equipment connected to the barrier must not use or generate more than 250 Vrms or Vdc.
3. Connect supply wires to the appropriate terminals as indicated on the terminal block and in the installation documents.
4. Installations should be in accordance with ANSI/ISA-RP12.6 "Installations of Intrinsically Safe Systems for Hazardous Locations" and the Canadian Electric Code.
5. Product options bearing the DUAL SEAL marking on the label meets the Dual Seal requirements of ANSI/ISA 12.27:01. No additional process sealing is required. For the in-service limits applicable to a specific model, see Process Pressure/Temperature range in Appendix A of the Reference manual.



## Figure 10. D9150079-907 - Installation Drawing for Hazardous Location Installation of ATEX and IECEx Approved Apparatus

<b>ORIGINAL SIZE A3</b>										
ISSUE	CL. ORDER NO.	REV.	ISSUE	CL. ORDER NO.	REV.	ISSUE	CL. ORDER NO.	REV.	ISSUE	CL. ORDER NO.
1.	39E-6400	001	39E-6400	001	39E-6400	001	39E-6400	001	39E-6400	001
2.	39E-6400	100	39E-6220	107	39E-6220	100	39E-6220	100	39E-6220	100
3.	39E-6400	100	39E-6220	107	39E-6220	100	39E-6220	100	39E-6220	100

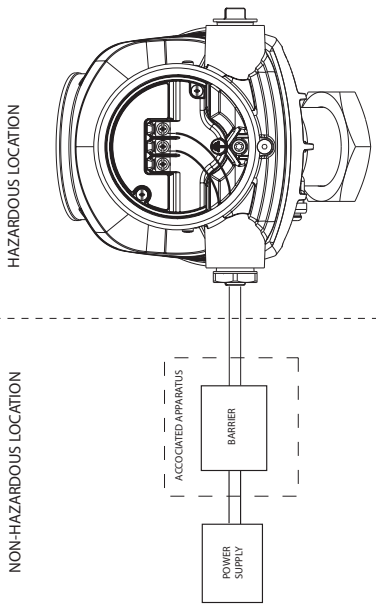

### ROSEMOUNT 5400 SERIES

#### INTRINSICALLY SAFE INSTALLATIONS

The approved values of maximum open circuit voltage (Uo) and maximum short circuit current (Io) and maximum output power (or Uo x Io / 4), for the associated apparatus must be less than or equal to the maximum open circuit voltage (Uo), maximum short circuit current (Io), and maximum safe output power of the intrinsically safe installation. The maximum safe output power of the intrinsically safe installation must be greater than the sum of the interconnecting cable capacitance (Co) of the associated apparatus must be greater than the sum of the interconnecting cable capacitance and the unprotected internal capacitance (Ci) of the intrinsically safe apparatus, and the approved maximum allowable connected inductance (Lo) of the associated apparatus must be greater than the sum of the interconnecting cable inductance and the unprotected internal inductance (Li) of the intrinsically safe apparatus.

#### Notes :

- Safety parameters listed (for HART/Fieldbus Model) apply only to associated apparatus with linear output.
- Control equipment connected to the barrier must not use or generate more than 250 Vrms or Vdc.
- Connect supply wires to the appropriate terminals as indicated on the terminal block table and in the installation documents.
- When model 5400 is supplied by an Ex.i.b certified safety barrier, following EPL classification applies for different parts of the transmitter.
  - The antenna part, located in the process vessel, is classified EPL Ga.
  - Transmitter head, is classified EPL Gb.

**EX-CERTIFIED PRODUCT.**  
No modifications permitted without reference to the Ex-certifying Authorities.

#### SPECIFIC CONDITIONS FOR SAFE USE (X) :

- The intrinsically safe circuits do not withstand the 500V AC test as specified in IEC 60079-11 clause 6.4.13.
- Potential ignition hazards by impact or friction need to be considered according to IEC 60079-0:2011 clause 8.3 (for EPL Ga and EPL Gb) and clause 8.4 (for EPL Da and EPL Db) , when the transmitter enclosure and antennas exposed to the exterior atmosphere of the tank, is made with light metals containing aluminium or titanium". The end user shall determine the suitability with regard to avoid hazards from impact and friction.
- The antennas for type 5400, are non-conducting and the area of the non-conducting part exceeds the maximum permissible areas for Group IIC and according to IEC 60079-0: 2011 clause 7.4 : 20 cm<sup>2</sup> for EPL Ga and 4 cm<sup>2</sup> for EPL Gb. Therefore, when the antenna is used in a potentially explosive atmosphere, appropriate measures must be taken to prevent electrostatic discharge.
- The Ex.i.a version of model 5400 may be supplied by an Ex.i to certified safety barrier. The whole circuit shall be regarded type Ex.i.b. The preferred type Ex.i.a or Ex.i.b shall be indicated on the marking label as specified in the instructions for the transmitter. The antenna part, located in the process vessel, is classified EPL Ga and electrically separated from the Ex.i.a or i.b circuit.
- ½" NPT threads need to be sealed for dust and water ingress protection, IP 66, IP 67 or Ex 1, EPL Da or Db is required.

#### Intrinsic Safety Parameters :

- I I G Ex Ia IIC T4 Ga or □ II 1/2 G Ex Ib IIC T4 Ga/Gb ;
- II D Ex Ia IIC T69°/T79° Dax;
- II ZD Ex Ib IIC T69°/T79° Da/Db

Model	Parameters	Ambient Temperature Limits
4-20 mA/HART IS Model	Ui ≤ 30V, Ii ≤ 130 mA Pi ≤ IW, Ci = 7.26nF, Li = 0	-50 ≤ Ta ≤ 70 deg C
Fieldbus IS Model	Ui ≤ 30V, Ii ≤ 300 mA Pi ≤ 19W, Ci = 90nF, Li = 0	-50 ≤ Ta ≤ 60 deg C
Fieldbus FISCO IS Model	Ui ≤ 17.5V, Ii ≤ 380 mA Pi ≤ 5.32W, Ci = 4.95nF, Li = 0	-50 ≤ Ta ≤ 60 deg C

<b>D9150079-907</b> <small>ALL DIMENSIONS ARE IN MILLIMETRES</small>		TITLE <b>INSTALLATION DRAWING</b> for hazardous location installation of ATEX and IECEx approved apparatus
WORK NO <b>D9150079-907</b>	SHEET NO <b>8</b>	SHEET TOTAL <b>1 / 1</b>
SCALE <b>1:1</b>	THE DESIGN/WORKING OF THIS DOCUMENT AND ALL INFORMATION CONTAINED THEREIN IS THE PROPERTY OF ROSEMOUNT. IT IS TO BE KEPT CONFIDENTIAL AND NOT TO BE REPRODUCED OR TRANSMITTED IN ANY FORM OR BY ANY MEANS, ELECTRONIC OR MECHANICAL, INCLUDING PHOTOCOPYING, RECORDING, OR BY ANY INFORMATION STORAGE AND RETRIEVAL SYSTEM, WITHOUT THE WRITTEN PERMISSION OF ROSEMOUNT.	

Figure 11. 9240031-958 - Installation Drawing Exn

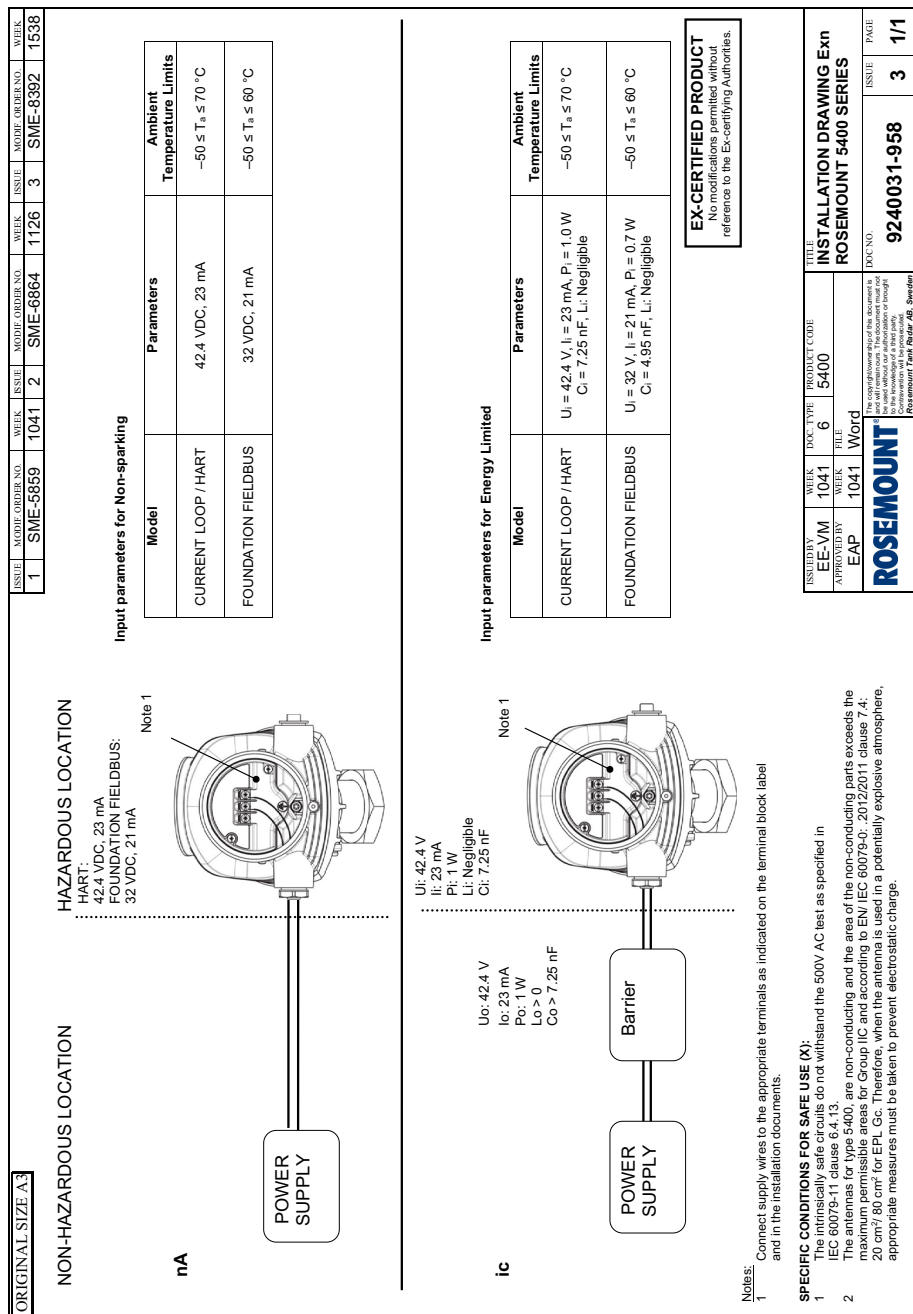

**List of Model Parts with China RoHS Concentration above MCVs**  
**含有China RoHS管控物质超过最大浓度限值的部件型号列表**

Part Name 部件名称	Hazardous Substances / 有害物质					
	Lead 铅 (Pb)	Mercury 汞 (Hg)	Cadmium 镉 (Cd)	Hexavalent Chromium 六价铬 (Cr +6)	Polybrominated biphenyls 多溴联苯 (PBB)	Polybrominated diphenyl ethers 多溴联苯醚(PBDE)
Electronics Assembly 电子组件	X	O	O	O	O	O
Housing Assembly 壳体组件	O	O	O	X	O	O

This table is proposed in accordance with the provision of SJ/T11364  
 本表格系依据SJ/T11364的规定而制作。

O: Indicate that said hazardous substance in all of the homogeneous materials for this part is below the limit requirement of GB/T 26572.

O: 意为该部件的所有均质材料中该有害物质的含量均低于GB/T 26572所规定的限量要求。

X: Indicate that said hazardous substance contained in at least one of the homogeneous materials used for this part is above the limit requirement of GB/T 26572.

X: 意为在该部件所使用的均质材料里，至少有一类均质材料中该有害物质的含量高于GB/T 26572所规定的限量要求。



**Global Headquarters**

**Emerson Automation Solutions**  
6021 Innovation Blvd.  
Shakopee, MN 55379, USA  
+1 800 999 9307 or +1 952 906 8888  
+1 952 949 7001  
RFQ.RMD-RCC@Emerson.com

**North America Regional Office**

**Emerson Automation Solutions**  
8200 Market Blvd.  
Chanhassen, MN 55317, USA  
+1 800 999 9307 or +1 952 906 8888  
+1 952 949 7001  
RMT-NA.RCCRFQ@Emerson.com

**Latin America Regional Office**

**Emerson Automation Solutions**  
1300 Concord Terrace, Suite 400  
Sunrise, FL 33323, USA  
+1 954 846 5030  
+1 954 846 5121  
RFQ.RMD-RCC@Emerson.com

**Europe Regional Office**

**Emerson Automation Solutions**  
Neuhofstrasse 19a P.O. Box 1046  
CH 6340 Baar  
Switzerland  
+41 (0) 41 768 6111  
+41 (0) 41 768 6300  
RFQ.RMD-RCC@Emerson.com

**Asia Pacific Regional Office**

**Emerson Automation Solutions**  
1 Pandan Crescent  
Singapore 128461  
+65 6777 8211  
+65 6777 0947  
Enquiries@AP.Emerson.com

**Middle East and Africa Regional Office**

**Emerson Automation Solutions**  
Emerson FZE P.O. Box 17033  
Jebel Ali Free Zone - South 2  
Dubai, United Arab Emirates  
+971 4 8118100  
+971 4 8865465  
RFQ.RMTMEA@Emerson.com



Linkedin.com/company/Emerson-Automation-Solutions



Twitter.com/Rosemount\_News



Facebook.com/Rosemount



Youtube.com/user/RosemountMeasurement



Google.com/+RosemountMeasurement

Standard Terms and Conditions of Sale can be found on the [Terms and Conditions of Sale page](#).

The Emerson logo is a trademark and service mark of Emerson Electric Co. DeltaV, Rosemount, and Rosemount logotype are trademarks of Emerson.

HART is a registered trademark of the FieldComm Group. FOUNDATION Fieldbus is a trademark of the FieldComm Group. Modbus is a registered trademark of Gould Inc. NEMA is a registered trademark and service mark of the National Electrical Manufacturers Association. National Electrical Code is a registered trademark of National Fire Protection Association, Inc. DTM is a trademark of the FDT Group. All other marks are the property of their respective owners. © 2017 Emerson. All rights reserved.