

USER MANUAL

Data Loggers Class 220

TABLE OF CONTENTS

1 SAFETY INSTRUCTIONS.....	4
1.1 Precautions.....	4
1.2 Symbols.....	4
2 DEVICE COMPONENTS.....	5
2.1 Use.....	5
2.2 Applications.....	5
2.3 Selection.....	5
2.4 Layout.....	5
2.5 Buttons.....	6
2.6 LEDs.....	6
2.7 Connections.....	6
2.8 Mounting.....	6
3 TECHNICAL FEATURES.....	7
3.1 Technical data.....	7
3.2 Housing.....	8
3.3 Directive: FCC part 15.....	8
3.4 Optional probes and cables.....	9
3.4.1 KT 220 and KH 220 optional probes, cables and ammeter clamps.....	9
3.4.2 KTT 220 optional thermocouple probes.....	10
3.5 Connect a probe on the universal input.....	10
3.6 Connect a probe on the thermocouple input.....	10
3.7 Dimensions.....	11
3.7.1 Devices.....	11
3.7.2 Wall mount.....	11
3.8 Warranty period.....	11
4 USE OF THE DEVICE.....	12
4.1 Display.....	12
4.2 Functions of LEDs.....	12
4.3 Configuration, data logger download and data processing with the KILOG software.....	13
4.4 Functions of buttons.....	13
4.4.1 Groups organization.....	15
4.4.2 Measurements scroll.....	15
4.5 PC communication.....	15
5 MAINTENANCE.....	16
5.1 Replace the battery.....	16
5.2 Device cleaning.....	16
5.3 Safety lock wall mount with padlock.....	16
6 CALIBRATION.....	17
7 ACCESSORIES.....	17
8 TROUBLESHOOTING.....	17

1 SAFETY INSTRUCTIONS

1.1 Precautions

Please always use the device in accordance with its intended use, and within the parameters described in the technical features page 7 in order not to compromise the protection ensured by the device.

Changes or modifications not expressly approved by Sauermann could void the user's authority to operate the equipment.

1.2 Symbols

For your safety and in order to avoid damage to the device, please follow the procedures described in this user manual and carefully read the notes that are preceded by the following symbol:



The following symbol will also be used in this user manual:
Please carefully read the information notes indicated after this symbol.



2 DEVICE COMPONENTS

2.1 Use

The class 220 data loggers measure several parameters:

- KT 220: internal measurement of temperature and one external universal input for probe
- KH 220: internal measurement of temperature, humidity and light and one external universal input for probe
- KTT 220: thermocouple temperature measurement with two thermocouple external inputs

This class of devices is available with or without display.

The communication between the device and the computer is carried out via USB cable with a female micro-USB connector.

2.2 Applications

The data loggers are ideal for the monitoring of several parameters (temperature, humidity, light, current, voltage, pulse, relative pressure). They ensure traceability in the food industry environment, as well as validate that industrial installations are functioning properly.



2.3 Selection

Part No.	Display	Internal sensors		External sensors		Parameters	Number of recording points
		Number	Type	Number	Type		
KT 220 - O	✓	1	Temperature	1	Input for universal probes*	Temperature, humidity, current, voltage, pulse & water pressure	1,000,000
KT 220 - N							
KH 220 - O	✓	3	Temperature, humidity & light			Temperature, humidity, current, voltage, pulse, water pressure & light	
KH 220 - N							
KTT 220 - O	✓	N/A		2	Inputs for thermocouple probes**	Temperature	
KTT 220 - N							

*Universal input allows compatibility with multiple probes. Reference page 9 for further information.

**Input allows compatibility with thermocouple probes. Reference page 10 for further information.

2.4 Layout



2.5 Buttons



OK button: start and stop the dataset, or switch between scrolling group (see page 13)



Selection button: select between values in a scrolling group (see page 13)

2.6 LEDs



2.7 Connections

The communication between the device and the computer is carried out via USB cable and with a female micro-USB connector.

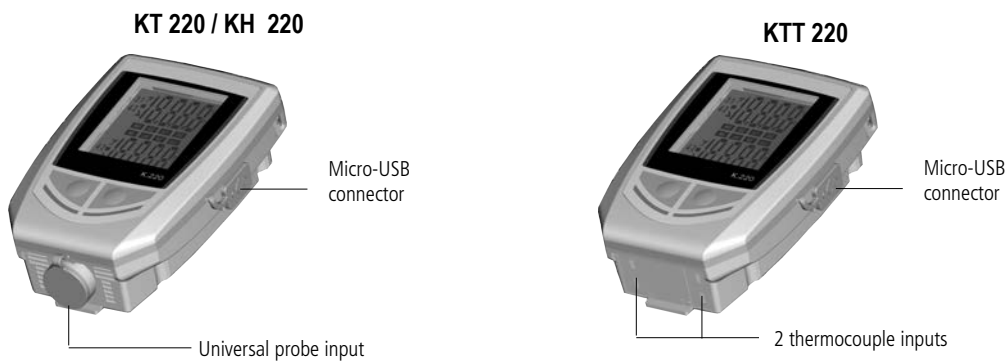

2.8 Mounting

The class 220 data loggers are equipped with a magnetic case for easy mounting.



3 TECHNICAL FEATURES

3.1 Technical data

	KT 220	KH 220	KTT 220
Units displayed	°F, °C, °Ctd, °Ftd, %RH, mV, V, mA, A, bar ¹	°F, °C, °Ctd, °Ftd, %RH, lux, fc, mV, V, mA, A, bar ¹	°F, °C
Resolution	0.1°F, 0.1°C, 0.1%RH, 1 mV, 0.001 V, 0.001 mA, 0.1 A, 0.1 bar	0.1°F, 0.1°C, 0.1%RH, 1 lux, 0.1 fc, 1 mV, 0.001 V, 0.001 mA, 0.1 A, 0.1 bar	0.1°F, 0.1°C
External input	Female micro-USB connector	Female micro-USB connector	Female micro-USB connector
Input for probe	1 universal input ²	1 universal input ²	2 inputs for thermocouple probes (K, J, T, N, S)
Internal sensor	Temperature	Temperature, humidity, light	Temperature
Type of sensor	Thermistor (NTC)	Thermistor (NTC), capacitive, photodiode	Thermocouple
Measuring range	Internal sensor ³ : -40 to 158°F (-40 to 70°C)	Internal sensor ³ : Temp.: -4 to 158°F (-20 to 70°C) Humidity: 0 to 100%RH Light: 0 to 10,000 lux	K: -328 to 2372°F (-200 to 1300°C) J: -148 to 1382°F (-100 to 750°C) T: -328 to 752°F (-200 to 400°C) N: -328 to 2372°F (-200 to 1300°C) S: 32 to 3200°F (0 to 1760°C)
Accuracies⁴	±0.8°F from -4 to 158°F (±0.4°C from -20 to 70°C) ±1.5°F below -4°F (±0.8°C below -20°C)	Temp: ±0.8°F from 32 to 122°F (±0.4°C from 0 to 50°C) ±1.5°F below 32°F or above 122°F (±0.8°C below 0°C or above 50°C) Humidity ⁵ : ±2%RH from 5 to 95%RH @ 59 to 77°F(15°C to 25°C) Light: ±10% of reading +10 lux	K, J, T, N: ±0.8°F from 32 to 2372°F (±0.4°C from 0 to 1300°C) ±(0.3% of the reading +0.8°F) below 32°F (±0.3% of the reading +0.4°C) below 0°C S: ±1.1°F (±0.6°C)
Operating temperature	-40 to 158°F (-40 to 70°C)	-4 to 158°F (-20 to 70°C)	-4 to 158°F (-20 to 70°C)
Storage temperature	-40 to 185°F (-40 to 85°C)	-40 to 185°F (-40 to 85°C)	From -40 to 185°F (-40 to 85°C)
Alarm set points	2 alarm set points per channel	2 alarm set points per channel	2 alarm set points per channel
Frequency of measurement	1 s to 24 h	1 s to 24 h	1 s to 24 h
Battery life	4 years ⁶	4 years ⁶	4 years ⁶
Warranty	1 year	1 year	1 year
Directives	2011/65/EU RoHS II; 2012/19/EU WEEE; FCC part 15; UL 61010		

¹ Some units are available only with optional probes.

² Universal input allows compatibility with multiple probes. Reference page 9 for further information.

³ Other measuring ranges are available according to the connected probe: see optional probes and cables page 9.

⁴ All accuracies specified in this document were conducted under laboratory conditions and can be guaranteed for measurement carried out in the same conditions, or carried out with calibration compensation.

⁵ Factory calibration tolerance: ±0.88%RH; Temperature dependence: ±0.04 x [(T °F - 32) x 5/9] - 20] %RH (if T ≤ 59°F or T ≥ 77°F) / ±0.04 x (T - 20) %RH (if T ≤ 15°C or T ≥ 25°C)

⁶ On the basis of 1 measurement each 15 minutes at 77°F (25°C).

3.2 Housing

Dimensions	3.67" x 2.57" x 1.20" (93.2 x 65.2 x 30.5 mm)
Weight	4 oz (115 g)
Display	2-line LCD screen (for models with display) Screen: 1.54" x 1.34" (39 x 34 mm) 2 indication LEDs (red and green)
Control	1 OK button 1 Selection button
Material	Compatible with food industry environment ABS housing
Protection	IP 65: KT 220 IP 54: KTT 220* IP 40: KH 220
PC communication	Female micro-USB connector USB cable
Battery power supply	1 AA lithium 3.6 V battery
Environmental conditions of use	Non-corrosive or combustible gases Hygrometry: in non-condensing condition Maximum altitude: 6561' (2000 m)

3.3 Directive: FCC part 15

 **Changes or modifications not expressly approved by Sauer mann could void the user's authority to operate the equipment.**





















This equipment has been tested and found to comply with the limits for a Class B digital device, pursuant to part 15 of the FCC Rules. These limits are designed to provide reasonable protection against harmful interference in a residential installation. This equipment generates uses and can radiate radio frequency energy and, if not installed and used in accordance with the instruction, may cause harmful interference to radio communications. However, there is no guarantee that interference will not occur in a particular installation. If this equipment does cause harmful interference to radio or television reception which can be determined by turning the equipment off and on, the user is encouraged to try to correct interference by one or more of the following measures:

- Reorient or relocate the receiving antenna.
- Increase the separation between the equipment and receiver.
- Connect the equipment into an outlet on circuit different from that to which the receiver is connected.
- Consult the dealer or an experienced radio/TV technician for help.

* With all the thermocouple probes connected.

3.4 Optional probes and cables





3.4.1 KT 220 and KH 220 optional probes, cables and ammeter clamps

Part No.	Description	Measuring ranges	Accuracies	Image & dimensions
Temperature and humidity probe				
KTHA	RH / temp. stub probe	0 to 100% RH	±2%RH from 5 to 95%RH @ 59°F to 77°F (15 to 25°C) Temp: ±0.9°F from 32 to 86°F (±0.5°C from 0 to 30°C)	 2.56" (65 mm)
KTHD	RH / temp. remote probe	-4 to 158°F (-20 to 70°C)	±(-2% of the measured value +1.8°F) below 32°F (±2% of the measured value ±0.6°C below 0°C) ±1.5% of reading above 86°F (±1.5% of the measured value above 30°C)	 5.12" (130 mm)
NTC Thermistor temperature probe				
KSI-50	2" immersion probe (IP 65)	-40 to 248°F (-40 to 120°C)	±0.8°F from -4 to 158°F (±0.4°C from 20 to 70°C) ±1.5°F (±0.8°C) beyond	 Ø0.24" x 1.97" (Ø6 x 50 mm)
KSI-150	6" immersion probe (IP 65)	-40 to 248°F (-40 to 120°C)	±0.8°F from -4 to 158°F (±0.4°C from 20 to 70°C) ±1.5°F (±0.8°C) beyond	 Ø0.24" x 5.9" (Ø6 x 150 mm)
KSA-150	Ambient air probe	-40 to 248°F (-40 to 120°C)	±0.8°F from -4 to 158°F (±0.4°C from 20 to 70°C) ±1.5°F (±0.8°C) beyond	 Ø0.24" x 5.9" (Ø6 x 150 mm)
KSF-2	Wire probe	-4 to 212°F (-20 to 100°C)	±0.8°F from -4 to 158°F (±0.4°C from 20 to 70°C) ±1.5°F (±0.8°C) beyond	 Ø0.12" (Ø3 mm)
KSP-150	Penetration probe (IP 68)	-40 to 248°F (-40 to 120°C)	±0.8°F from -4 to 158°F (±0.4°C from 20 to 70°C) ±1.5°F (±0.8°C) beyond	 Ø0.12" x 5.9" (Ø3 x 150 mm)
KSP-150	Penetration probe (IP 65)	-40 to 248°F (-40 to 120°C)	±0.8°F from -4 to 158°F (±0.4°C from 20 to 70°C) ±1.5°F (±0.8°C) beyond	 Ø0.18" x 5.9" (Ø4.5 x 150 mm)
KCV-220	Velcro probe	-4 to 194°F (-20 to 90°C)	±0.8°F from -4 to 158°F (±0.4°C from 20 to 70°C) ±1.5°F (±0.8°C) beyond	 Ø0.18" x 5.9" (Ø4.5 x 150 mm)
Relative pressure probe (water probes)				
KSPE	Relative pressure probe for liquids and gases (corrosive)	0 to 150 psi (0 to 10 bar)	±2.9 psi (±0.2 bar)	 3.66" (93 mm)
KSPE-2	High relative pressure probe for liquids and gases (corrosive)	0 to 300 psi (0 to 20 bar)	±2.9 psi (±0.2 bar)	 3.66" (93 mm)
Current / voltage / pulse input cables				
KCTD-10-B	Voltage input cable	0 to 5V or 0 to 10V	±0.2% of the measurement ±1mV	
KCCD-02-B	Current input cable	0 to 20 mA or 4 to 20 mA	±0.2% of the measurement ±1µA	
KCTD-1-B	Pulse input cable		Max. voltage: 5V Input: TTL frequency counting Max. frequency: 10 KHz	
Ammeter clamps				
KPID-100-BRF	Low current intensity ammeter clamp	1 to 100 A _{AC} Frequency range: 40 Hz to 5000 Hz	±1% of reading ±0.1 A	 
KPID-200-BRF	Moderate current intensity ammeter clamp	1 to 200 A _{AC} Frequency range: 40 Hz to 5000 Hz	±1% of reading ±0.2 A	 
KPID-600-BRF	High current intensity ammeter clamp	1 to 600 A _{AC} Frequency range: 40 Hz to 5000 Hz	±2.5% of reading ±0.6 A	 

* All accuracies specified in this document were conducted under laboratory conditions and can be guaranteed for measurements carried out in the same conditions, or carried out with compensation.

3.4.2 KTT 220 optional thermocouple probes

All the thermocouple temperature probes for the KTT 220 data loggers have a class 1 sensitive element as per IEC 584-1, 2 and 3 standards.

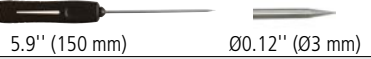
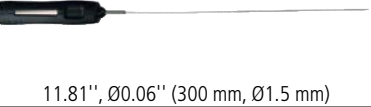
Part No.	Description	Measuring ranges	Accuracies*	T ₉₉ **	Image & dimensions
<i>Pipes</i>					
SKV 150	Contact probe with velcro Velcro fixing for Ø 3.94" (Ø 100 mm) maxi pipes with cable (Tc K)	-4 to 194°F (-20 to 90°C)	±2.7°F (±1.5°C)	50 s	
SKCT	Contact probe with lamella for Ø 0.34" to 1.97" pipes (Ø 10 to 50 mm) with spring handle and straight cable (Tc K)	-40 to 302°F (-40 to +150°C)	±2.7°F (±1.5°C)	15 s	
<i>Contact</i>					
SCLK 150	Contact probe with lamella with handle and coiled cable (Tc K)	-40 to 482°F (-40 to 250°C)	±2.7°F (±1.5°C)	5 s	 5.9" (150 mm) Ø0.59" (Ø15 mm)
SCLCK 150	Contact probe with lamella, angled at 90° with handle and coiled cable (Tc K)	-40 to +482°F (-40 to +250°C)	±2.7°F (±1.5°C)	5 s	 5.9" (150 mm) Ø0.59" (Ø15 mm)
<i>Penetration</i>					
SPK 150	Penetration probe. Stainless steel contact tip with pointed contact tip, handle and coiled cable (Tc K)	-40 to 482°F (-40 to 250°C)	±2.7°F (±1.5°C)	30 s	 5.9" (150 mm) Ø0.12" (Ø3 mm)
<i>Immersion</i>					
SIT 300 BT	Very low temperature immersion probe. Deformable lined contact tip with handle and coiled cable. (Tc T)	-328 to 122°F (-200 to 50°C)	±(-1.5% of reading +0.5°F) from -328 to -88.6°F (±1.5% of reading from -200 to -67°C) ±1.8°F from -88.6 to -40°F (±1°C from -67 to -40°C) ±0.9°F from -40 to 122°F (±0.5°C from -40 to 50°C)	2 s	 11.81", Ø0.06" (300 mm, Ø1.5 mm)

* All accuracies specified in this document were conducted under laboratory conditions and can be guaranteed for measurements carried out in the same conditions, or carried out with compensation.

** Response time. Under application condition.

3.5 Connect a probe to the universal input

- Open the mini-DIN connection cap on the bottom of the data logger.
- Connect the probe in such a way the mark on the probe facing the user.

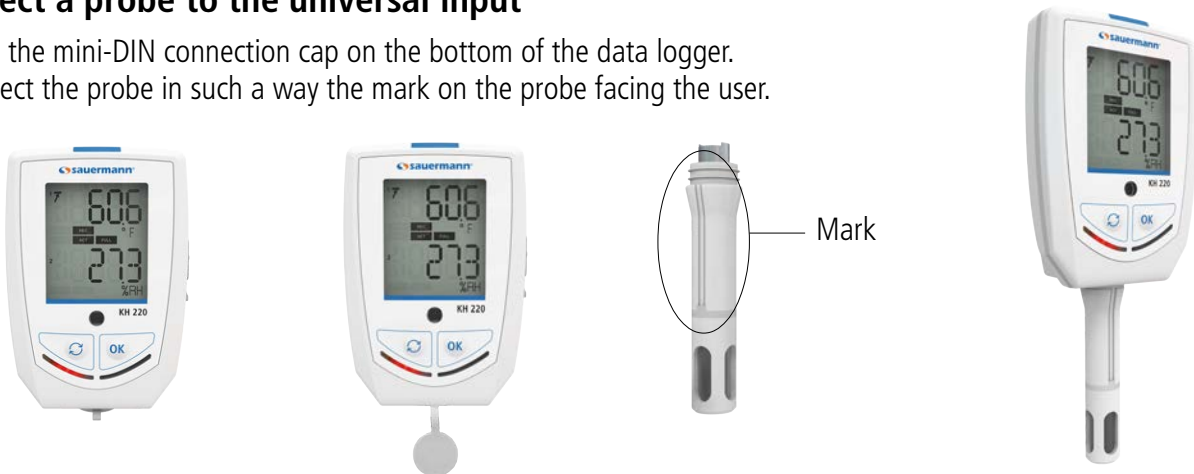

3.6 Connect a probe to the thermocouple input

- To connect the thermocouple probe to the bottom of the device, the smallest thermocouple connection must be placed on top and the largest on the bottom of the plug.



3.7 Dimensions

3.7.1 Devices

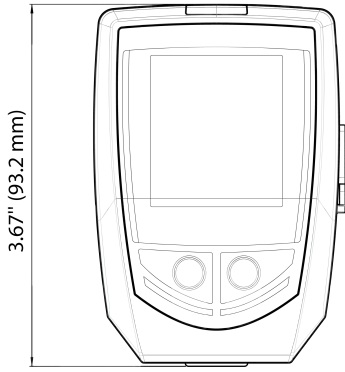
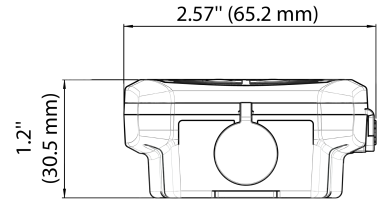
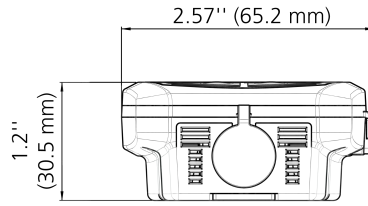
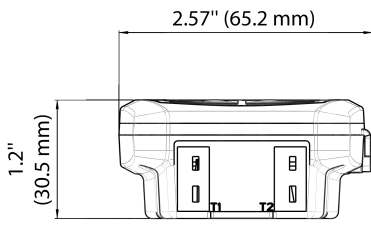

KTT 220

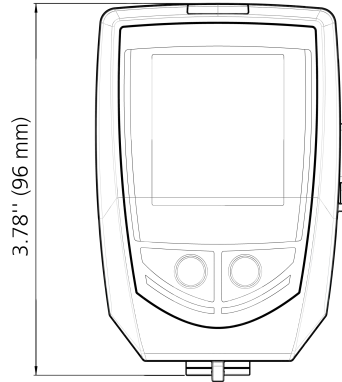

KH 220

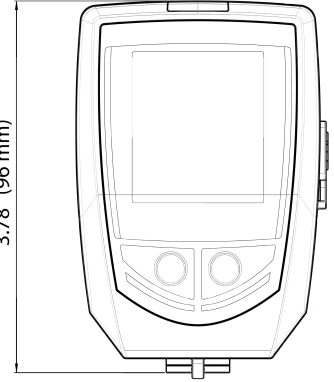

KT 220

3.7.2 Wall mount

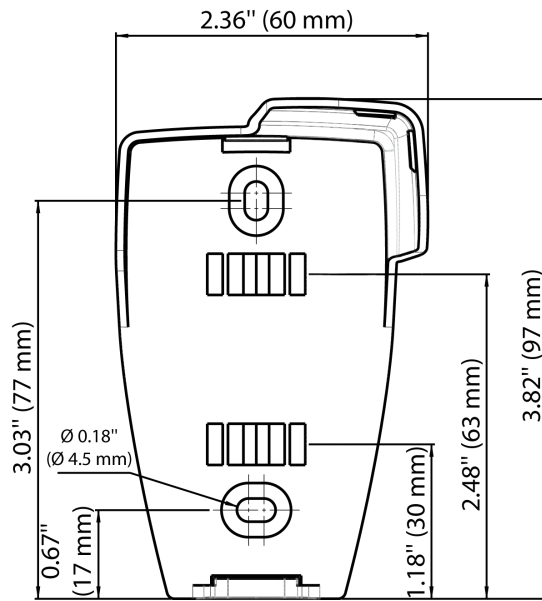
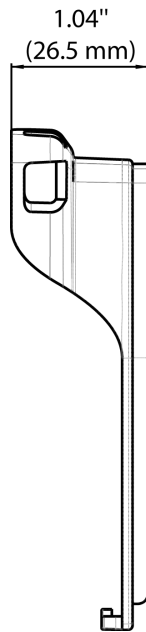

3.8 Warranty period

Data loggers have a 1-year warranty for any manufacturing defect (warranty returns must be processed through Sauermaann's After-Sale Service Dept.).

4 USE OF THE DEVICE

4.1 Display

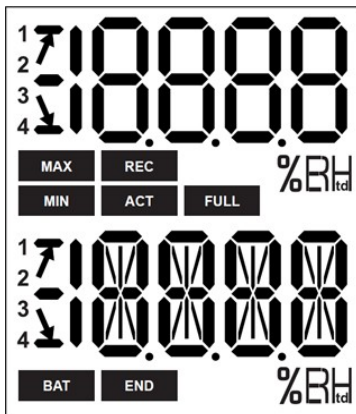

END DATASET is finished.

REC Indicates that one value is being recorded.
Flashing: the DATASET did not start.

FULL Flashing slowly: DATASET is between 80% and 90% of the storage capacity.
Flashing quickly: DATASET is between 90% and 100% of the storage capacity.
Constant: storage capacity full.

BAT Constant: indicates that the batteries have to be replaced.

ACT Screen actualization of measured values.

MIN
MAX The displayed values are the maximum/minimum values recorded for the channels displayed.

Indicates the alarm action type: rising or falling.

Temperature in °Fahrenheit.

Temperature in °Celsius.

Relative humidity (KH 220).

1
2 Indicates the channel number which is
3 measuring.
4

The selected values to display during the configuration with the KILOG software will scroll on the screen every 3 seconds.

The display can be activated or deactivated via the KILOG software.

At extreme temperatures, the display can become difficult to read and the display speed can slow down at temperatures below 32°F (0°C). This has no effect on the measurement accuracy.

4.2 Functions of LEDs



If the red "Alarm" LED has been activated, it has 3 states:

- **Always OFF:** no setpoint alarms has been exceeded.
- **Flashing quickly (5 seconds):** a threshold is currently exceeded on at least one channel.
- **Flashing slowly (15 seconds):** at least one threshold has been exceeded during the dataset.

If the green "ON" LED has been activated, it flashes every 10 seconds during the recording period.

4.3 Configuration, data logger download and data processing with the KILOG software























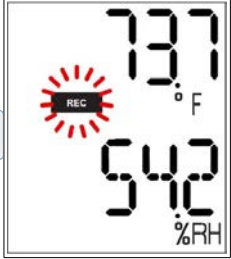

Please see the **KILOG** software user manual: "KILOG software".

 **The date and time updates automatically when a new configuration is loaded.**

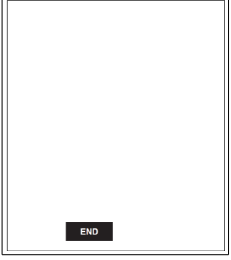
4.4 Functions of buttons

 **OK button:** start and stop the dataset or switch between scrolling groups as described in the following tables.





 **Selection button:** select values in the scrolling group as described in the following tables.

Device state	Type of start/stop selected	Button used	Action generated	Illustration
Waiting for start  flashes	Start: by button	 Hold for 5 seconds	Dataset starting	  Hold for 5 seconds 
	Stop: not relevant in this mode		Inactive	
	Start by PC, date / time		Inactive	
	Stop: not relevant in this mode			
			Measurements scrolling (group 1)*	    
Dataset in progress 	Start: not relevant in this mode		Dataset stop	  Hold for 5 seconds 
	Stop: by button			
	Start: not relevant to change groups		Group change (groups 2 and 3)*	    
	Stop: not relevant to change groups			

* Please see the summary table of the groups organization on page 14.

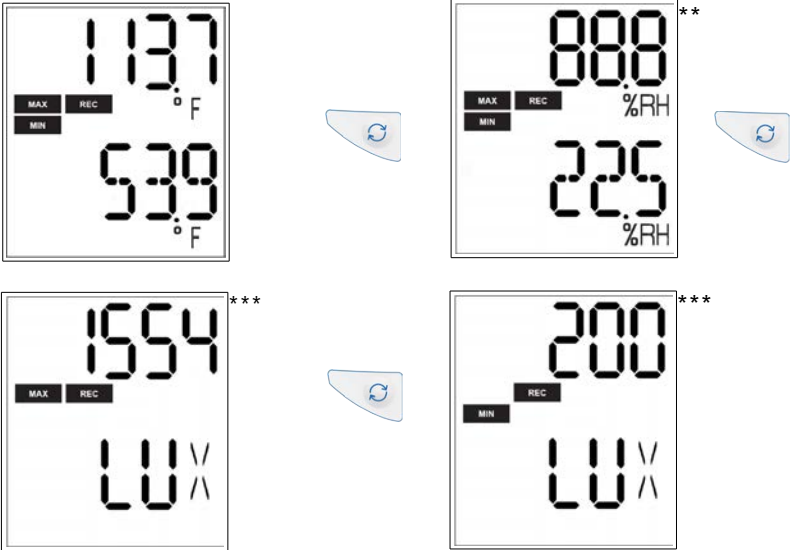
** %RH: only the KT 220 and KH 220.

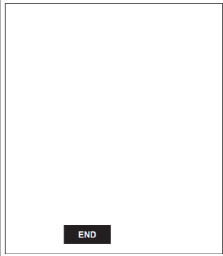
*** Lux: only the KH 220.

Device state	Type of start/stop selected	Button used	Action generated	Illustration
Dataset in progress REC			Group scrolling (groups 1, 2 and 3)*	
Dataset finished END	There is no restart after the dataset has ended		Inactive	
			Measurements scrolling*	

* Please see the summary table of the groups organization on the following page.

** %RH: only the KT 220 and KH 220.



*** Lux: only the KH 220.

4.4.1 Groups organization

The table below summarizes the groups organization and measured values available during a measurement dataset.



	Group 1	Group 2	Group 3
Measured temperature		Max. value in temperature Min. value in temperature	High alarm threshold in temperature Low alarm threshold in temperature
Measured humidity*		Max. value in humidity* Min. value in humidity*	High alarm threshold in humidity* Low alarm threshold in humidity*
Measured light*		Max. value in light* Min. value in light*	High alarm threshold in light* Low alarm threshold in light*
Probe 1 measured parameter*		Max. value for probe 1* Min. value for probe 1*	High alarm threshold for probe 1* Low alarm threshold for probe 1*
Probe 2 measured parameter*		Max. value for probe 2* Min. value for probe 2*	High alarm threshold for probe 2* Low alarm threshold for probe 2*

Press  to switch between groups.
 Press  to select values in the scrolling group.

4.4.2 Measurements scroll

According to the selected parameters during the configuration and according to the type of device, the measurement scroll is carried out as follows:

Temperature ➡ Humidity* ➡ Light* ➡ Parameter 1 of probe* ➡ Parameter 2 of probe*

4.5 PC communication

- Insert the CD-ROM in the reader and follow the installation procedure of the **KILOG** software.
1. Plug the male USB connector of the cable to a USB connection on your computer**.
 2. Open the USB cap on the right side of the data logger.
 3. Connect the male micro-USB connector of the cable to the female micro-USB connector of the device.



* Parameters available according to the device and probe type.
 ** The computer must be in compliance with the UL60950 standard.

5.1 Replace the battery

With 4 years* of battery life, the data logger guarantees long-term measurement. The **BAT** icon appears when the battery has to be replaced.

To replace the battery:

1. Unscrew the 4 screws on the back side of the device with a screwdriver.
2. Remove the back side and the old batteries.
3. Insert the new battery and respect the polarity.

➤ Replace the back side and secure the 4 screws with a screwdriver.

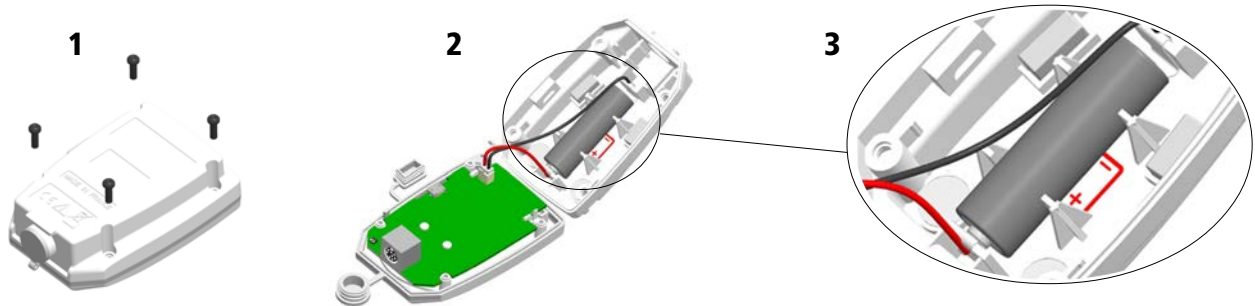

 Only use trademark or high quality batteries in order to guarantee proper battery life.

 After the battery replacement, the device must be reconfigured.

5.2 Device cleaning

Please avoid any aggressive solvent.

Please protect the device and probes from any cleaning product containing formaldehyde that may be used to clean rooms and ducts.

5.3 Safety lock wall mount with padlock

- Mount the safety lock support on the desired place.
1. Set the data logger on the support starting with the bottom part.
 2. Clip the data logger on the support by placing the logger into the mount.
 3. Insert the padlock to ensure the safety lock function.



➤ To remove the data logger from the support, proceed on reverse order.

 The padlock can be replaced by a safety seal.







 The data logger can be placed on the screw-mount without the safety lock function.

* On the basis of 1 measurement each 15 minutes at 77°F (25°C).

6 CALIBRATION

Calibration certificates are available - we recommend annual calibration.

7 ACCESSORIES

Part No.	Description	Image
KILOG-LITE	Free basic software for configuration, and data download (tabular & graphical).	
KILOG-3-N	Premium software for configuration, data download, and fast and easy data saving, processing, and calculations.	
KBL-AA	1 AA lithium battery	
KAV-220	Safety lock wall mount with padlock	
KRB-220	Wired extension for class 220 data logger probes 16' (5 m) length with male & female mini-DIN connectors (up to 5 extensions can be wired together for greater length requirements)	
CK-50	USB / micro USB cable (connects the data logger to a PC)	



Recommended accessories to be used with data loggers

8 TROUBLESHOOTING

Problem	Probable cause and possible solution
No value is displayed, only the icons are present.	The display is set "OFF" . Set it on "ON" with the KILOG software (see page 13).
"hi" or "lo" is displayed	The measurement range is exceeded. There is a problem with the sensing element.
The display is completely off* and there is no communication with the computer.	The battery must be replaced. (see page 16).
The display indicates "- - -" instead of the measured value.	The probe is disconnected. Plug it again to the data logger.

* For models with display.



BE CAREFUL! Material damages can happen, so please apply the precautionary measures indicated.