

Method of Implementation (MOI) PCI Express 3.0 Transmitter & Receiver Return Loss Test

Using Keysight Vector Network Analyzer with Enhanced TDR App



Table of Contents

1. Revision History.....	3
2. Configuration Requirements	4
3. Test Procedure	5
3.1. Test Flow Chart	5
3.2. Description of Measurement Window.....	6
4. Measurement Setups.....	7
4.1. Recalling a State File.....	7
4.2. Perform Calibration Setup.....	9
4.2.1. ECal Calibration and De-embedding	9
5. Measurement and Data Analysis.....	12
5.1. Transmitter and Receiver Differential Return Loss (RL_DIFF).....	12
5.2. Transmitter and Receiver Common Mode Return Loss (RL_COMM).....	13
6. [Appendix] Manual Setup	14
6.1. Channel & Trace Setup.....	14
6.2. Impedance.....	15
6.3. Differential Return Loss	15
6.4. Common-Mode Return Loss	15
6.5. Defining Limit Line Tables.....	15
7. [Appendix] De-embedding File Creation using VNA.....	16
7.1. De-embedding File for Replica Channel.....	16
7.2. Breakout and Replica Channels.....	17
Web Resources.....	18

1. Revision History

Revision	Comments	Date
1.0	First draft for E5080B series	30-July-2020

Reference documents

1. PCI Express® Base Specification Revision 3.0; (Nov 10, 2010).

2. Configuration Requirements

Description	Test Equipment	Qty
Network Analyzer	<p>Keysight's Vector Network Analyzer:</p> <p><u>2-Ports (Min):</u></p> <ul style="list-style-type: none"> • E5080B-2K0: 2-Ports, 9 kHz to 20 GHz or • P5004A-200 Streamline USB Series VNA or • M9374A PXI Multiport VNA <p><u>4-Ports (Recommended):</u></p> <ul style="list-style-type: none"> • E5080B-4K0: 4-port test set, 9 kHz to 20 GHz or • P5024A-400 Streamline USB Series VNA or • M9804A-400 PXI Multiport VNA <p>Note: Ensure that VNA firmware revision is at least version A.14.10 or above (Windows 10)</p>	1 ea.
Software	<p>S9x011A/B Enhanced time-domain analysis with TDR</p> <p>* Selection is based on the VNA platforms. x=6 for ENA, x=7 for Streamline USB, x=5 for PXI</p>	1 ea.
ECal or Mechanical Cal Kit	<p>Min. 2-Ports Electronic Calibration (ECal) Module</p> <p>EG: N7555A 2-Ports or N4433D-010/0DC 4-Ports</p>	1 ea.
Adapter	<p>3.5mm(f)-Type N(m) adapters (Keysight 1250-1744).</p>	4 ea.
RF cable	<p>3.5 mm or SMA cables of 4 GHz bandwidth or more</p> <p>* Y1740A-100 (3.5-mm m-m, 36 inch) cable is recommended for USB and PXI VNA</p>	2 ea.
Terminator	<p>50-ohm terminations to terminate unused channels (EG: Keysight 909D-301)</p>	2 ea.

3. Test Procedure

3.1. Test flow chart

1

Host DUT setup

- The DUT must be powered up and DC isolated, and its data+/data- outputs /inputs must be in the low-Z state at a static value Also, make sure that Spread Spectrum Clocking (SSC) is turned off.

2

VNA Pre-setup.

- Power on and warm-up the VNA unit for >15 Mins

3

Launch Enhanced-TDR app and Recall state file (*.tdr)

4

Perform ECal and De-embedding.

5

Perform Tx/Rx Impedance in Time Domain

6

Perform Tx/Rx Return Loss Measurements in Frequency Domain

Note:

1. Hard Keys displayed in **Blue color** and **Bold**. (Example: **Avg, Analysis**)
2. Soft keys (Keys on the screen) are displayed in **Bold**. (Example: **S11, Real, Transform**)
3. Buttons (in the TDR) are displayed in **Green color** and **Bold**. (Example: **Trace, Rise Time**)
4. Tabs (in the TDR) are displayed in **Brown color** and **Bold**. (Example: **Setup, Trace Control**)

3.2. Description of measurement window

The following figure is the description of the measurement window.

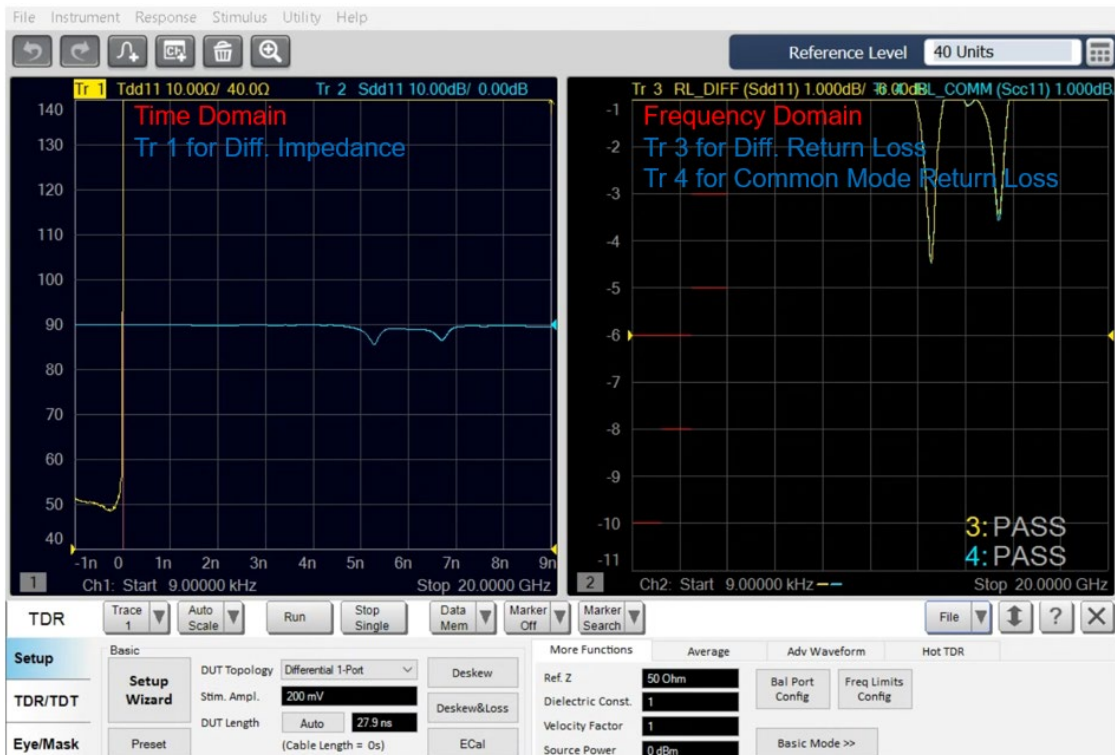
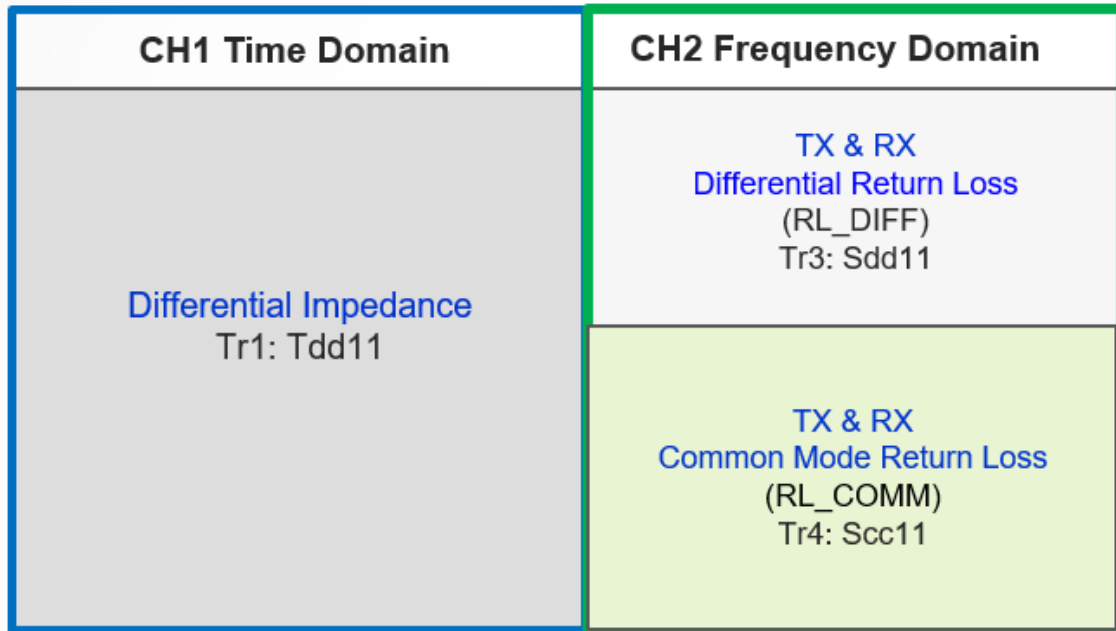

Actual measurement windows in the state file

4. Measurement Setups

4.1. Recalling a state file

This section describes how to recall a state file for Time Domain and Frequency Domain settings.

A state file can be downloaded from Keysight.com at the following URL.

www.keysight.com/find/ena-tdr_compliance

If you use your local PC to download, save the state file to a USB mass storage device in order to move it to the VNA unit. Connect the USB mass storage device into the front USB port of the VNA unit.

For manual measurement settings, refer to Chapter 6.0 Appendix for manual setup procedure.

1. Click **Setup** > **Main** > **Meas Class...** to launch measurement class setup dialog box
2. Select **TDR** and click OK.

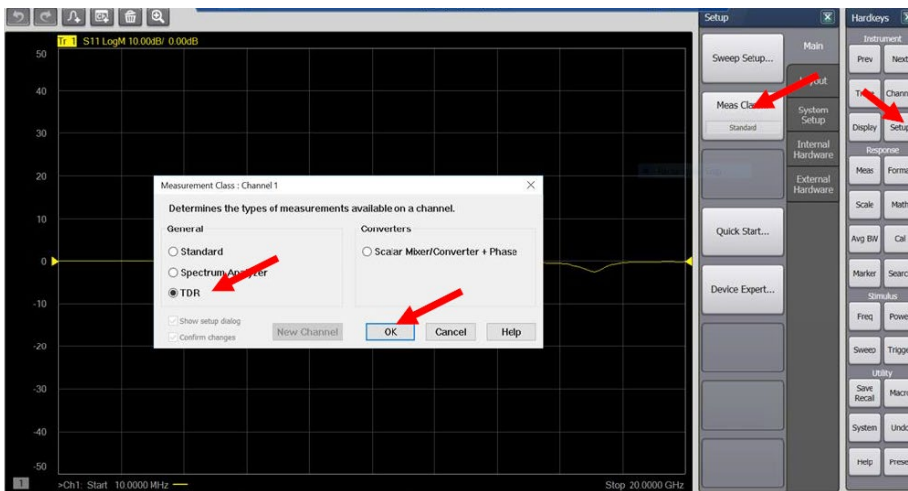

3. Select Close and confirm with Yes to close the setup wizard.

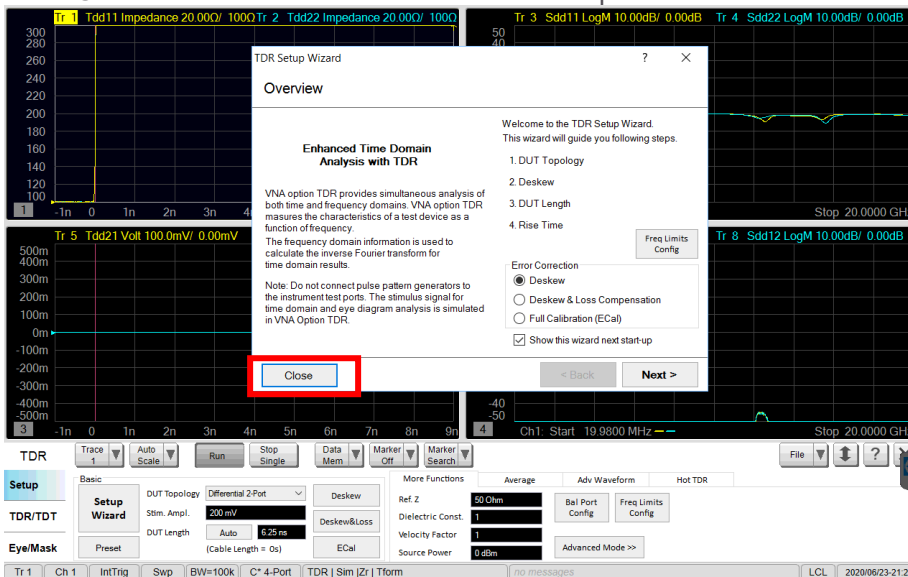

- Select Click **Advanced Mode** of TDR software and Click Yes to enter the advanced mode.

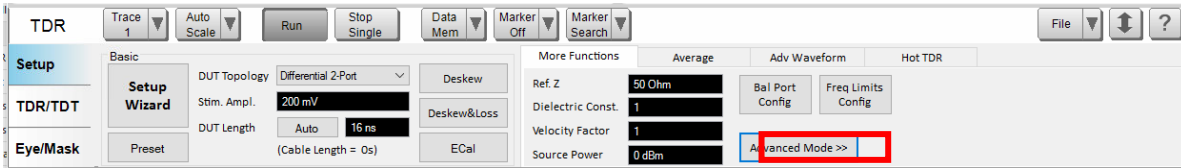

- Click **File > Recall State**. Select the state file (*.tdr) and click Open to recall.

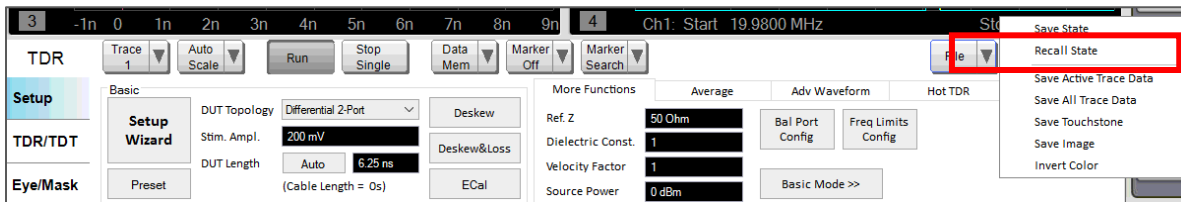

- The windows will launch pre-define state file configuration for USB4 Return Loss testing.

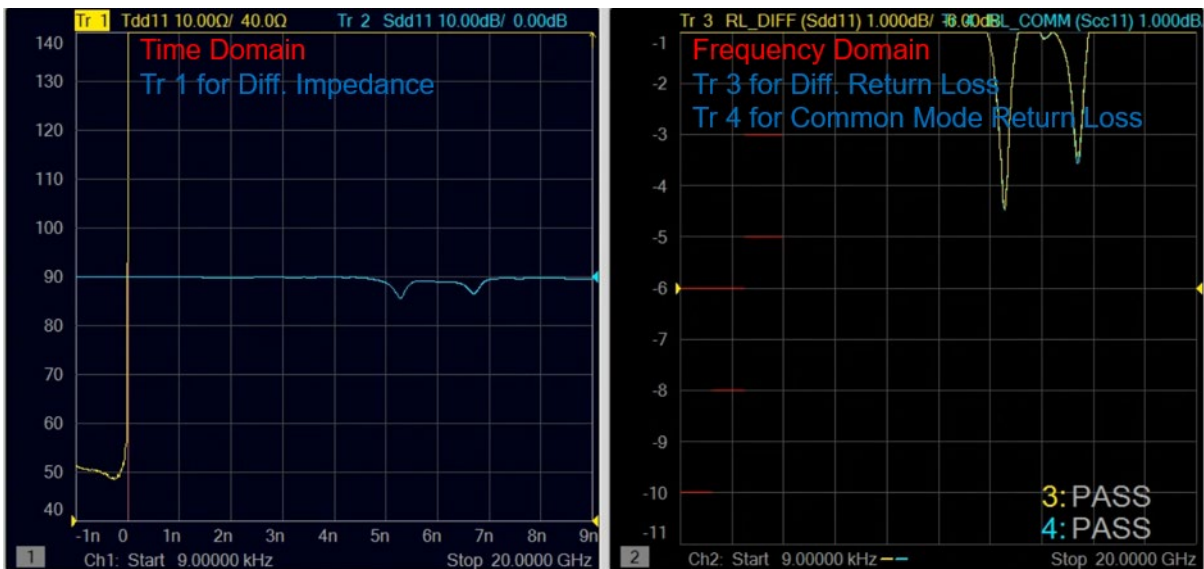

- All the measurement settings including calibration information can be saved. Select **File > Save State As... > State and Cal Set Date (*.csa)** to save the settings.

4.2. Perform calibration setup

The purpose of this step is to calibrate the RF effects such as delay, loss or mismatch of RF cables and test fixture traces before measurements.

Tx/Rx return loss measurements are specified in the PCIe 3.0 BASE Specification, so the measurements are defined to be performed at the device's pin. However, the pin of a device under test (DUT) is not generally accessible, and the closest accessible point is usually a pair of microwave-type coaxial connectors separated from the DUT pins by several inches of PCB trace, called the **breakout channel**.

Specifically, Tx/Rx return loss measurements are made at the end of the respective breakout channels and require that the breakout channel's contribution to RL be de embedded, thereby associating the return loss with the Tx or Rx pin. The replica channel reproduces the electrical characteristics of the breakout channel as closely as possible, matching its length, layer transitions, etc., making it possible to de embed measurements to the pin of the DUT.

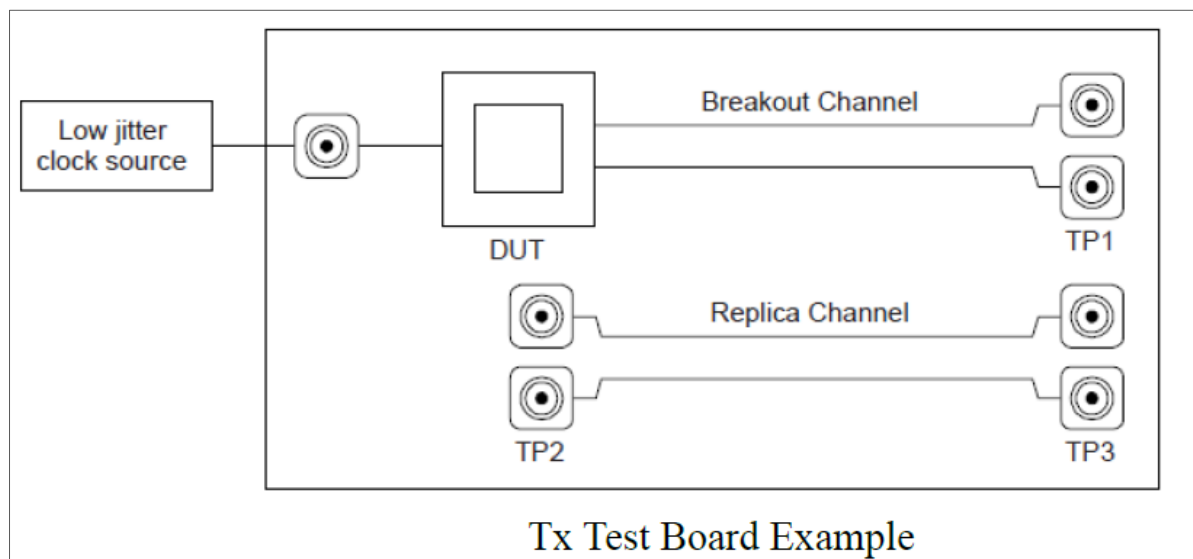

4.2.1. ECal calibration and de-embedding

Full calibration is performed by using the 4-port ECal Module (i.e. N4433A) at the end of RF cables connected to the VNA's test ports. The effect of the fixture is removed by de-embedding the fixture traces with S-parameter Touchstone files.

ECal calibration on time domain:

ECal calibration for time-domain measurements is performed by the TDR software.

1. Press **Channel Next** to select Channel 1.
2. Click **Setup** tab.
3. Click **ECal** to launch the TDR Setup Wizard.

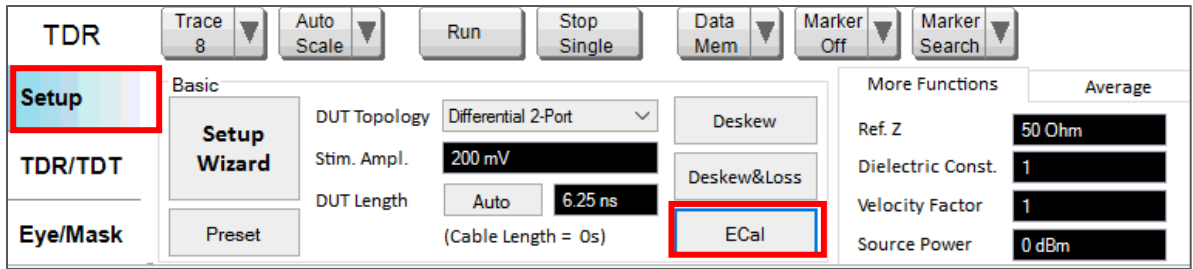

4. Connect the VNA ports (Port 1 and Port 2) to the ECal module with RF cables. Terminate unused ports with 50-Ohm terminators.
5. Click **Calibrate** button to perform ECal Calibration.

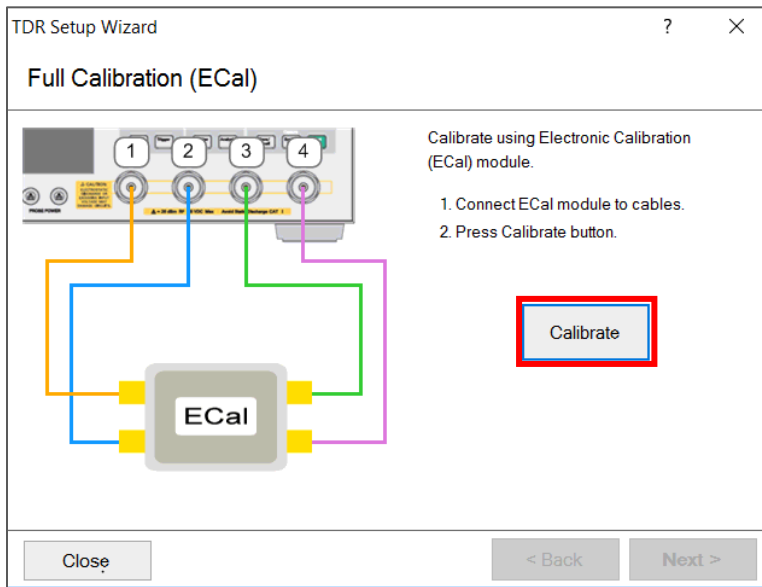

6. Click **Next >** to proceed. Completed calibration will show Green ✓ sign
7. Click **Finish** to complete the ECal.

De-embedding on time domain:

1. Click **Adv Waveform** tab > **De-embedding** to launch Advanced Waveform wizard.



2. Click De embedding box to set the Touchstone file. 2 port files (*.s2p) for single ended lines or 4 port files (*.s4p) for differential lines can be selected for the de embedding function.
3. Load the Touchstone file.
4. Enable the de-embedding function and Click OK.

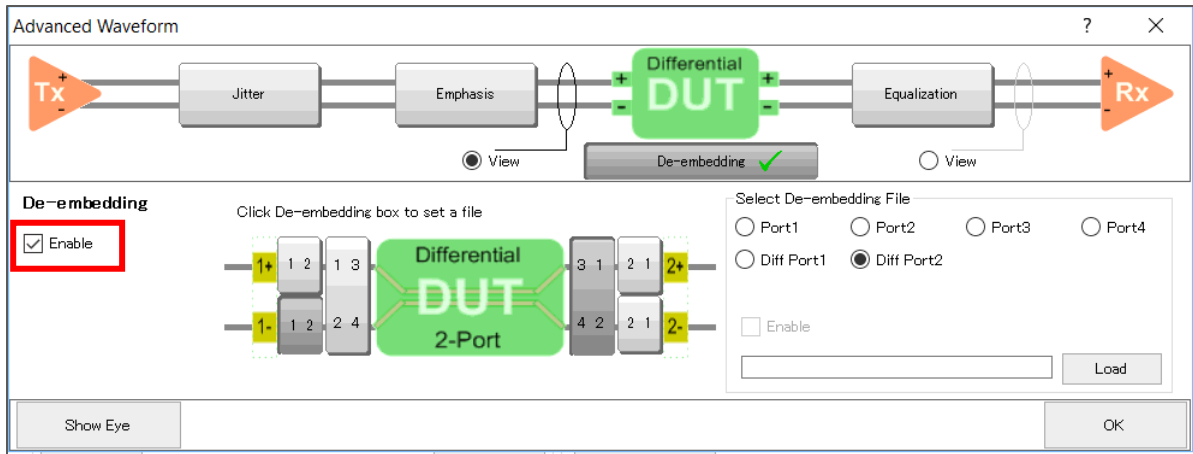

Note: For more details about the de-embedding function, refer to the VNA help below.

http://ena.support.keysight.com/e5080/manuals/webhelp/eng/index.htm#S3_Cals/Fixturing.htm#deembed

ECal calibration on fFrequency domain:

ECal calibration for frequency-domain measurements are performed by the VNA firmware.

1. Press **Channel Next** to select Channel 2.
2. Connect the VNA ports (Port 1 and Port 2) to the ECal module with RF cables.
3. Press **Cal > Main > Other ECal > Ecal...** > select **2-Port ECal** and click **Next** to proceed
4. Click **Finish** when the ECal is completed.

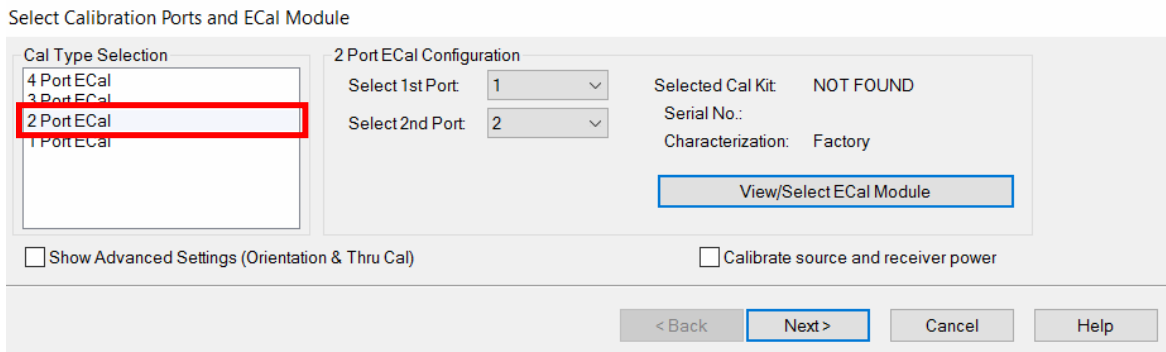

5. Measurement and Data Analysis

Return loss measurements for the Tx and Rx are essentially identical, so both are included in the Transmitter section. Return loss measurements are made at the end of the respective breakout channels and require that the breakout channel's contribution to RL be de-embedded, thereby associating the return loss with the Tx or Rx pin. Return loss measurements are made with a reference impedance of 50 ohms. Both differential and common mode are defined over a frequency range of 50 MHz to 4.0 GHz.

The DUT must be powered up and DC isolated, and its data+/data- outputs /inputs must be in the low Z state at a static value Also, make sure that Spread Spectrum Clocking (SSC) is turned off.

Return Loss	2.5 GT/s	5 GT/s	8 GT/s
TX/RX Differential Return Loss (RL_DIFF), Sdd11	-10 dB	-8 dB	-5 dB
TX/RX Common-Mode Return Loss (RL_COMM), Scc11	-6 dB	-6 dB	-3 dB

Note: Refer figure: 4-56 and figure: 4-57 in PCIe3.0 base specification.

5.1. Transmitter and receiver differential return loss (RL_DIFF)

This test ensures that the Differential Return loss falls within the limits of the PCIe 3.0 Specification.

1. Connect the VNA ports (Port 1 to 2) to the breakout channel with RF cables. Unused TX/RX lane that is not under test should be terminated with 50-ohm terminators.
2. Power up and place the DUT (TX/RX) data+/data- outputs in the low-Z state at a static value under the actual operating condition.
3. Select **Trace 1 (Tdd11)**.
4. Press **Double-click** on the instrument front panel to enlarge the trace.
5. Press **Run** and ensure the measured output impedance is within the tolerance (**100 Ω ±10%**).
6. Press Channel **Next** to select **Channel 2** (Frequency Domain).
7. Select **Trace 3 (Sdd11)**.
8. Press **Double-click** on the instrument front panel to enlarge the trace.
9. Press **Trigger** > Single.
10. Run and confirm the measured values is within the limit shown below. Otherwise, it will show Fail.

Frequency	Stop Frequency	Start Limit	Stop Limit
0.05 GHz	1.25 GHz	-10.00 dB	-10.00 dB
1.25 GHz	2.50 GHz	-8.00 dB	-8.00 dB
2.50 GHz	4.00 GHz	-5.00 dB	-5.00 dB



5.2. Transmitter and receiver common mode return loss (RL_COMM)

This test ensures that the Common Mode Return loss falls within the limits of the PCIe 3.0 Specification.

1. Connect the VNA ports (Port 1 to 2) to the breakout channel with RF cables according to the Table below. Unused TX/RX lane that is not under test should be terminated with 50-ohm terminators.
2. Power up and place the DUT (TX/RX) data+/data- outputs in the low-Z state at a static value under the actual operating condition.
3. Select **Trace 1 (Tdd11)**.
4. Press **Double-click** on the instrument front panel to enlarge the trace.
5. Press **Run** and ensure the measured output impedance is within the tolerance ($100 \Omega \pm 10\%$).
6. Press Channel **Next** to select **Channel 2** (Frequency Domain).
7. Select **Trace 4 (Scc11)**.
8. Press **Double-click** on the instrument front panel to enlarge the trace.
9. Press **Trigger** > Single.
10. Run and confirm the measured values is within the limit shown below. Otherwise, it will show Fail.

Frequency	Stop Frequency	Start Limit	Stop Limit
0.05 GHz	2.50 GHz	-6.0 dB	-6.0 dB
2.50 GHz	4.00 GHz	-3.0 dB	-3.0 dB

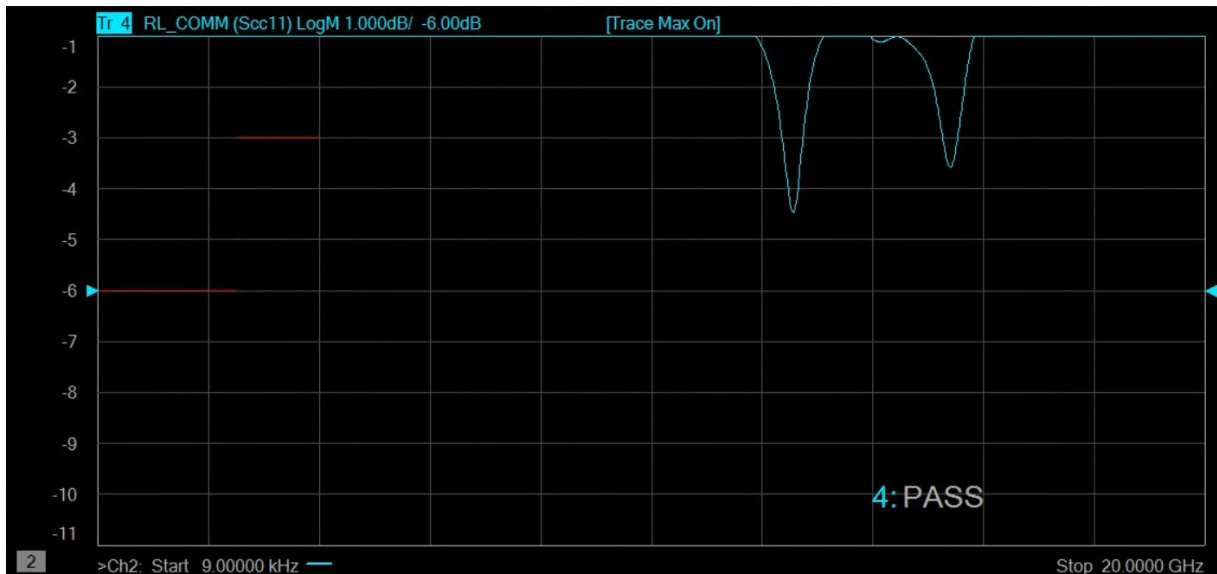

6. [Appendix] Manual Setup

The procedures of manual setup for time domain and frequency domain measurements are introduced in this section for reference. All the required testing parameters have been properly set and saved in the respective standards testing state file (*.tdr).

6.1. Channel & trace setup

If TDR setup wizard is shown when launching the TDR software, click **Close** button in the TDR setup wizard main window.

1. Open **Setup** tab in the TDR software
2. Click **Preset** to preset the instrument Click OK in a dialog box to continue.
3. Set **DUT Topology** to “**Differential 1 Port**” Click OK in a dialog box.
4. Click **Advanced Mode>>** and click Yes to enter to Advanced mode.
5. Click **Stop Single**.
6. Set DUT Length to “27.9 ns”.
7. Click **More Functions** tab.
8. Input Source Power “-20 dBm”.

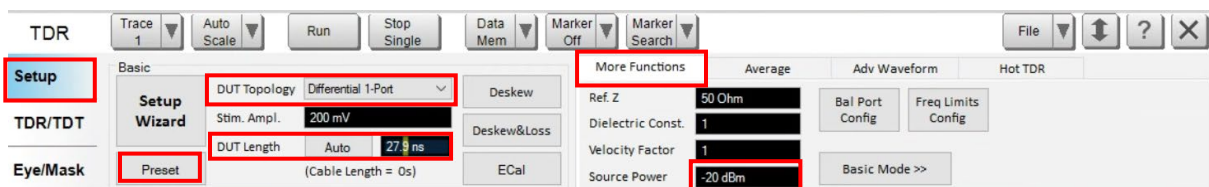

6.2. Impedance

1. Select **Trace 1**.
2. Open **Parameters** tab.
3. Select “**Time Domain**” and “**Differential**” for Measure.
4. Select Formant to “**Impedance**”.
5. Select **Rise Time** to “**10-90%**” and input value “**156 ps**”.
6. Click **Tdd11**.
7. Input vertical scale (5 Ohm/div) and vertical position (60 Ohm).
8. Input horizontal scale (1 ns/div) and horizontal position (1 ns).

6.3. Differential return loss

1. Select **Trace 3**.
2. Open **Parameters** tab.
3. Select “**S-Parameter**” and “**Differential**” for Measure.
4. Select Formant to “**Log Mag**”.
5. Select **Rise Time** to “**10-90%**” and input value “**156 ps**”.
6. Click **Sdd11**.
7. Input vertical scale (10 dB/div) and vertical position (-30 dB).

6.4. Common-mode return loss

1. Select **Trace 4**.
2. Open **Parameters** tab.
3. Select “**S-Parameter**” and “**Differential**” for Measure.
4. Select Formant to “**Log Mag**”.
5. Select **Rise Time** to “**10-90%**” and input value “**156 ps**”.
6. Click **Scc11**.
7. Input vertical scale (10 dB/div) and vertical position (-30 dB).

6.5. Defining limit line tables

1. Press **Trace Next** to select trace to set the limit line table.
2. Press **Math** > Analysis > Limit Table > to edit the limit table.

	Type	Begin Stimulus	End Stimulus	Begin Response	End Response
1	Max	0.000000 Hz	5.00000 GHz	-30.0000 dB	-30.0000 dB
2	Off	0.000000 Hz	0.000000 Hz	0.000000 dB	0.000000 dB

3. Press **Math** > Analysis > Limit... > to launch Limit Test Setup window.
4. Select to turn on “Limit Test ON” and “Limit Line ON”, optional to turn on “Sound ON Fail”.

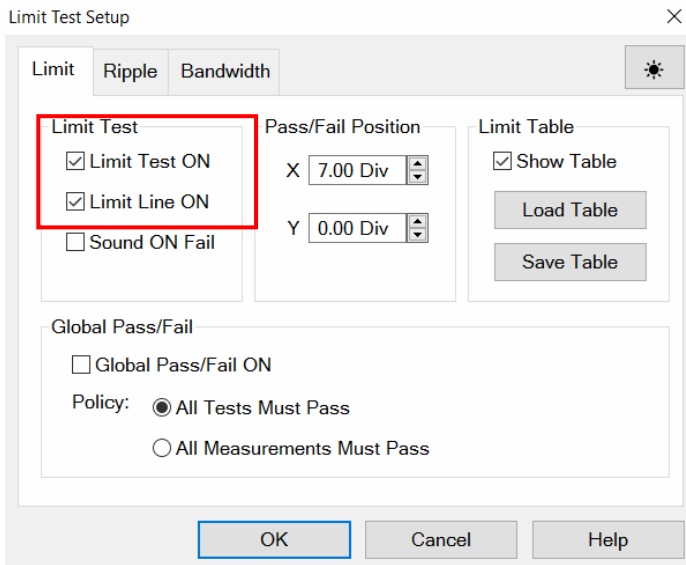

7. [Appendix] De-embedding File Creation using VNA

Direct probing at pins is generally not feasible. Therefore, data should measure at the end of the breakout channel. By means of the replica channel it is possible to determine the loss Vs. frequency characteristics of the breakout channel and de-embed the channel. The loss effects of the breakout channel may be minimized by de-embedding.

7.1. De-embedding file for replica channel

1. Recall the state file as described in Section 4.1. Recalling a State File.
2. Perform the calibration using ECal and De-embedding.
3. Double-click to maximize the selected trace on the screen.
4. Select **Trace 3**.
5. Open **TDR/TDT** tab.
6. Open **Parameters** tab.
7. Click **Sdd21**.
8. Connect the VNA ports (port 1 to 4) to replica channel with RF cables as shown below (1, 2, 3, 4 are VNA port numbers).

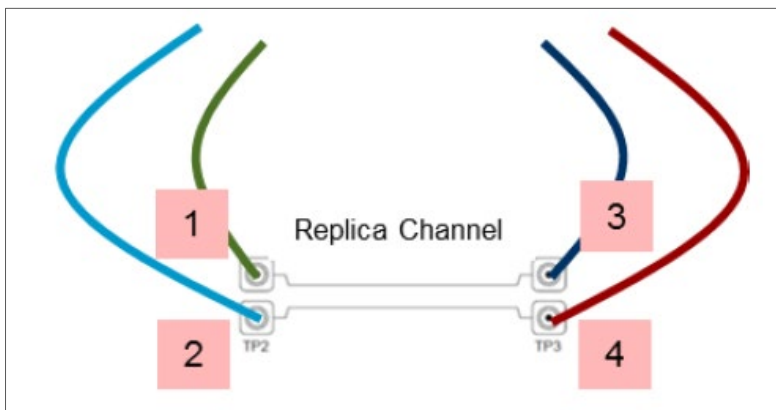

9. Click **Stop Single**.
10. Click **File** and select **Save Touchstone**.
11. Specify a folder and a file name and click **Save**(* .s4p).
12. Click **Sdd11**.

7.2. Breakout and replica channels

Break-out channels should be designed to have an insertion loss of less than 2 dB and a return loss of greater than 15 dB at 4 GHz, which may require use of low loss dielectric, wide signal traces and back-drilling of breakout vias or use of micro-via technology. The impedance targets for the breakout channel are 100-ohm differential and 50 ohm single-ended. For best accuracy the actual breakout channel impedance should be within $\pm 10\%$ of these values. For larger deviations a more complex de-embedding technique may be required.

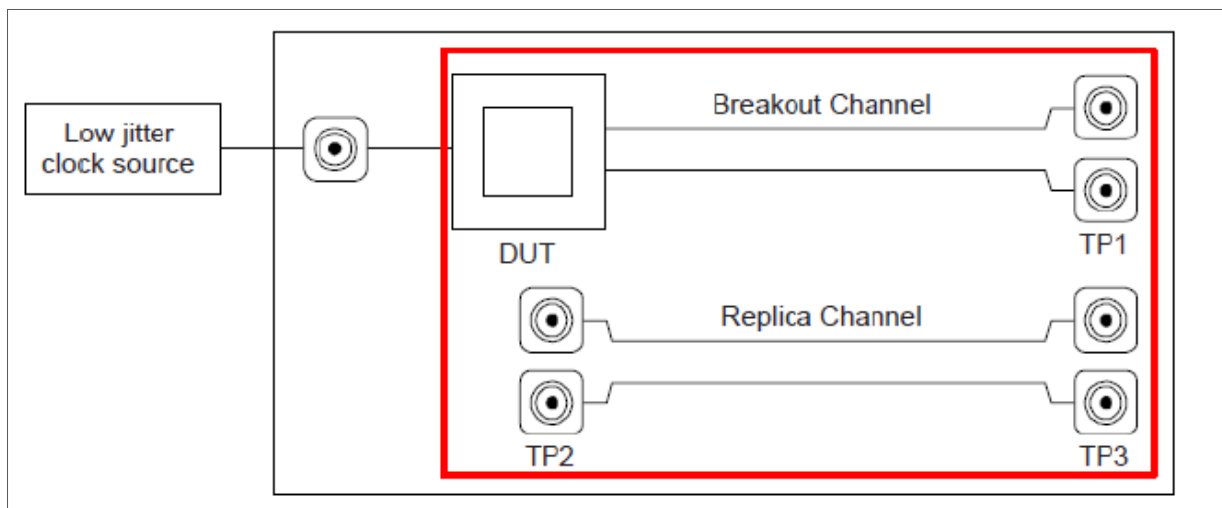

TX test board example

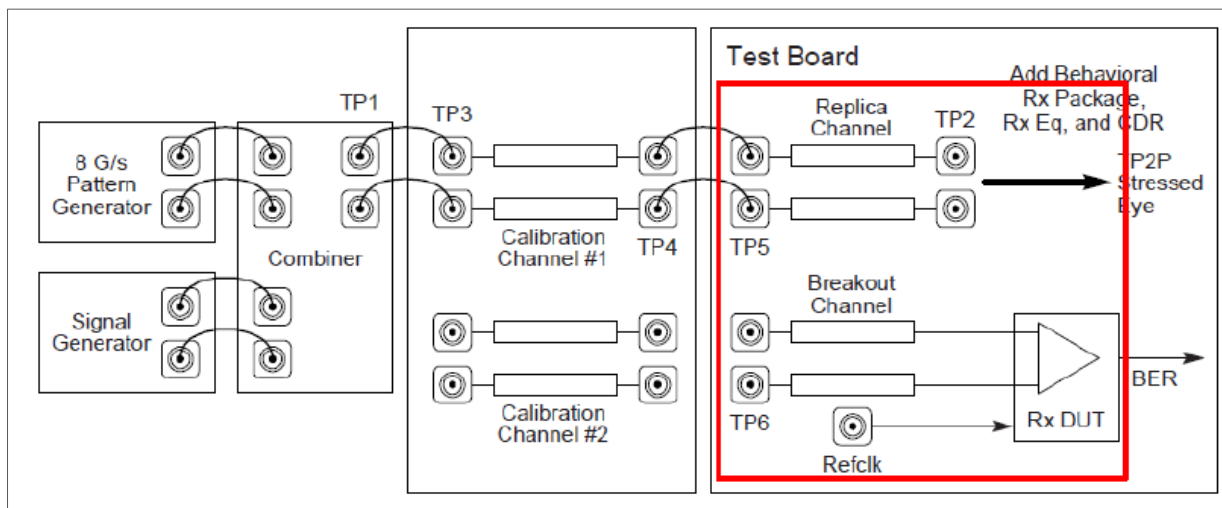

RX test board example

Web Resources

www.keysight.com/find/ena-tdr_compliance

www.keysight.com/find/usb-vna

www.keysight.com/find/na

www.keysight.com/find/vnasoftware

www.keysight.com/find/ecal

Learn more at: www.keysight.com

For more information on Keysight Technologies' products, applications or services, please contact your local Keysight office. The complete list is available at:

www.keysight.com/find/contactus

