

Version 2.2
February 2021

Xerox® VersaLink® C400 Color Printer Xerox® VersaLink® C405 Color Multifunction Printer Customer Expectation and Installation Guide

Xerox® VersaLink® C400 Color Printer

Xerox® VersaLink® C405 Color Multifunction Printer

© 2017 Xerox Corporation. All rights reserved. Unpublished rights reserved under the copyright laws of the United States. Contents of this publication may not be reproduced in any form without permission of Xerox Corporation.

Copyright protection claimed includes all forms of matters of copyrightable materials and information now allowed by statutory or judicial law or hereinafter granted, including without limitation, material generated from the software programs which are displayed on the screen such as styles, templates, icons, screen displays, looks, and so on.

Xerox® and Xerox and Design®, Phaser®, PhaserSMART®, PhaserMatch®, PhaserCal®, PhaserMeter™, ®, PagePack®, eClick®, PrintingScout®, Walk-Up®, WorkCentre®, FreeFlow®, SMARTsend®, Scan to PC Desktop®, MeterAssistant®, SuppliesAssistant®, Xerox Secure Access Unified ID System®, Xerox Extensible Interface Platform®, ColorQube®, ConnectKey®, Global Print Driver®, VersaLink™, AltaLink™, and Mobile Express Driver® are trademarks of Xerox Corporation in the United States and/or other countries.

Adobe® Reader®, Adobe® Type Manager®, ATM™, Flash®, Macromedia®, Photoshop®, and PostScript® are trademarks of Adobe Systems Incorporated in the United States and/or other countries.

Apple®, Bonjour®, EtherTalk™, TrueType®, iPad®, iPhone®, iPod®, iPod touch®, Mac® and Mac OS® are trademarks of Apple Inc., registered in the U.S. and other countries. AirPrint® and the AirPrint Logo® are trademarks of Apple Inc.

Google Cloud Print™ web printing service, Gmail™ webmail service, and Android™ mobile technology platform are trademarks of Google, Inc.

HP-GL®, HP-UX®, and PCL® are trademarks of Hewlett-Packard Corporation in the United States and/or other countries.

IBM® and AIX® are trademarks of International Business Machines Corporation in the United States and/or other countries.

Microsoft®, Windows Vista®, Windows®, and Windows Server® are trademarks of Microsoft Corporation in the United States and other countries.

McAfee®, ePolicy Orchestrator®, and McAfee ePO™ are trademarks or registered trademarks of McAfee, Inc. in the United States and other countries.

Novell®, NetWare®, NDPS®, NDS®, IPX™, and Novell Distributed Print Services™ are trademarks of Novell, Inc. in the United States and other countries.

PANTONE® and other Pantone, Inc. trademarks are the property of Pantone, Inc.

SGI® and IRIX® are trademarks of Silicon Graphics International Corp. or its subsidiaries in the United States and/or other countries.

Sun, Sun Microsystems, and Solaris are trademarks or registered trademarks of Oracle and/or its affiliates in the United States and other countries.

UNIX® is a trademark in the United States and other countries, licensed exclusively through X/ Open Company Limited.

Wi-Fi CERTIFIED Wi-Fi Direct® is a trademark of the Wi-Fi Alliance.

BR678

Product Overview

Introduction

This document is intended to help you understand the performance and capabilities of the Xerox® C400 and Xerox® C405, including information on optional accessories. Installation planning information is provided later in this document and it contains specifications and guidelines for installing your device. Specifications and data in this document include Xerox and customer proprietary information. The customer will use all reasonable efforts to safeguard the document, will not disclose its contents to third parties, and should only circulate it within the organization on a need-to-know basis.

Product Highlights

The compact C400 and C405 excel in small office environments where high-impact speed, and ease of use are important.

Convenience

- Compact designs fit in tight busy spaces
- Optional Wireless Adapter allows untethered mobility with new Wi-Fi installation wizard and WPS setup
- Wi-Fi Direct (with optional Wi-Fi kit)
- NFC tap-to-pair
- Apple® AirPrint®
- Mopria®

Performance

- Up to 36ppm
- Dual head single pass scanner (MFP only)
- Large 550 Sheet Paper Tray
- Hefty processing power with generous amount of standard memory
- Outstanding output image quality

Ease

- Large 5.0" color capacitive touchscreen (swipe) interface
- Scan to email (MFP only)
- Scan to (MFP only) and print from USB at the device
- App Gallery inbox App for easy access to downloadable Apps

System / Product Configuration

Each version of the product will be available in the following configurations. The C400 will be available in the Printer only configuration at 36 ppm. The C405 will be available in 36 ppm Multi-Function Printer configurations. Both configurations will also be available in duplex and non-duplex versions.

C400 Color Printer



C405 Color Multifunction Printer



Detailed Specifications and Product Brochure

VersaLink C400/C405 Product Brochure

[Xerox VersaLink C400 Color Printer and Xerox VersaLink C405 Color Multifunction Printer Brochure](#)

VersaLink C400 – Detailed Specification Sheet

[Xerox® VersaLink® C400 Color Printer](#)

Versalink C405 -Detailed Specification Sheet

[Xerox® VersaLink® C405 Color Multifunction Printer](#)

Maintenance and Support

This section helps define the support and services that Xerox will supply and what is expected of the customer.

Customer/Operator Maintenance

Support Services

The majority of service related issues can be resolved by the customer using the Xerox Online Support tools from the front panel of the device, the device driver resident on the computer, or through the device Embedded Web Server page. To supplement the Xerox Online Support experience, knowledgeable support resources will be available via the phone. The phone support resources typically resolve issues on the first call. In the event phone support is required, customers will be expected to actively participate in the phone diagnosis and service processes. For issues that cannot be resolved over the phone, customers will typically receive onsite field service the following day from a combination of Xerox Employees and Xerox Authorized National Service Providers.

In addition to onboard, driver based customer tools, telephone and on-site service, customers will also have access to web technical support:

www.xerox.com/officeprinting/support/.

Call procedure

Contact your local sales and service team for details:

Product Sustainability

Packaging Take-Back Service for Xerox Branded Products: (US only) Whenever possible, Xerox encourages you to recycle packaging locally as it reduces greenhouse gas emissions associated with transportation. However, if unable to recycle locally, we offer a packaging take-back and recycling service to our customers for Xerox branded products, where customers pay for the return shipping and Xerox pays for the recycling. If interested in this service, please send your packaging to: Xerox Corporation, ESSO – Scrap, 6500 State Route 63, Middletown, OH 45044 , ATTN: EPEAT Packaging Returns.

Supplies and Consumables

Xerox supplies for your machine, including paper and CRUs, can be ordered from Xerox by going to www.xerox.com and clicking on either the Contact Us link for specific contact information/telephone numbers in your area or by clicking on the Supplies and entering/selecting your specific machine information (product family and model type).

Note: Always refer to www.xerox.com for the latest Customer Replaceable Units (CRUs) part numbers.

Supplies Recycling Program

Consumables for this product are part of the Xerox Green World Alliance Supplies Recycling Program. For more information, please visit the Green World Alliance website at www.xerox.com/gwa.

Recommended Supplies

Item	Description/Yield	Xerox Order#
Sold Toner - NA/XE	BLACK STANDARD CAPACITY TONER CARTRIDGE C400/C405 2.5K PAGES	106R03500
Sold Toner - NA/XE	YELLOW STANDARD CAPACITY TONER CARTRIDGE C400/C405 2.5K PAGES	106R03501
Sold Toner - NA/XE	CYAN STANDARD CAPACITY TONER CARTRIDGE C400/C405 2.5K PAGES	106R03502
Sold Toner - NA/XE	MAGENTA STANDARD CAPACITY TONER CARTRIDGE C400/C405 2.5K PAGES	106R03503
Sold Toner - DMO	BLACK STANDARD CAPACITY TONER CARTRIDGE C400/C405 2.5K PAGES	106R03508
Sold Toner - DMO	YELLOW STANDARD CAPACITY TONER CARTRIDGE C400/C405 2.5K PAGES	106R03509
Sold Toner - DMO	CYAN STANDARD CAPACITY TONER CARTRIDGE C400/C405 2.5K PAGES	106R03510
Sold Toner - DMO	MAGENTA STANDARD CAPACITY TONER CARTRIDGE C400/C405 2.5K PAGES	106R03511

Sold Toner - NA	BLACK HIGH CAPACITY TONER CARTRIDGE C400/C405 5K PAGES	106R03512
Sold Toner - NA	YELLOW HIGH CAPACITY TONER CARTRIDGE C400/C405 4.8K PAGES	106R03513
Sold Toner - NA	CYAN HIGH CAPACITY TONER CARTRIDGE C400/C405 4.8K PAGES	106R03514
Sold Toner - NA	MAGENTA HIGH CAPACITY TONER CARTRIDGE C400/C405 4.8K PAGES	106R03515
Sold Toner - XE	BLACK HIGH CAPACITY TONER CARTRIDGE C400/C405 5K PAGES	106R03516
Sold Toner - XE	YELLOW HIGH CAPACITY TONER CARTRIDGE C400/C405 4.8K PAGES	106R03517
Sold Toner - XE	CYAN HIGH CAPACITY TONER CARTRIDGE C400/C405 4.8K PAGES	106R03518
Sold Toner - XE	MAGENTA HIGH CAPACITY TONER CARTRIDGE C400/C405 4.8K PAGES	106R03519
Sold Toner - DMO	BLACK HIGH CAPACITY TONER CARTRIDGE C400/C405 5K PAGES	106R03520
Sold Toner - DMO	YELLOW HIGH CAPACITY TONER CARTRIDGE C400/C405 4.8K PAGES	106R03521
Sold Toner - DMO	CYAN HIGH CAPACITY TONER CARTRIDGE C400/C405 4.8K PAGES	106R03522
Sold Toner - DMO	MAGENTA HIGH CAPACITY TONER CARTRIDGE C400/C405 4.8K PAGES	106R03523
Sold Toner - NA	BLACK EXTRA HIGH CAPACITY TONER CARTRIDGE C400/C405 10.5K PAGES	106R03524
Sold Toner - NA	YELLOW EXTRA HIGH CAPACITY TONER CARTRIDGE C400/C405 8K PAGES	106R03525
Sold Toner - NA	CYAN EXTRA HIGH CAPACITY TONER CARTRIDGE C400/C405 8K PAGES	106R03526
Sold Toner - NA	MAGENTA EXTRA HIGH CAPACITY TONER CARTRIDGE C400/C405 8K PAGES	106R03527
Sold Toner - XE	BLACK EXTRA HIGH CAPACITY TONER CARTRIDGE C400/C405 10.5K PAGES	106R03528
Sold Toner - XE	YELLOW EXTRA HIGH CAPACITY TONER CARTRIDGE C400/C405 8K PAGES	106R03529
Sold Toner - XE	CYAN EXTRA HIGH CAPACITY TONER CARTRIDGE C400/C405 8K PAGES	106R03530
Sold Toner - XE	MAGENTA EXTRA HIGH CAPACITY TONER CARTRIDGE C400/C405 8K PAGES	106R03531
Sold Toner - DMO	BLACK EXTRA HIGH CAPACITY TONER CARTRIDGE C400/C405 10.5K PAGES	106R03532
Sold Toner - DMO	YELLOW EXTRA HIGH CAPACITY TONER CARTRIDGE C400/C405 8K PAGES	106R03533
Sold Toner - DMO	CYAN EXTRA HIGH CAPACITY TONER CARTRIDGE C400/C405 8K PAGES	106R03534
Sold Toner - DMO	MAGENTA EXTRA HIGH CAPACITY TONER CARTRIDGE C400/C405 8K PAGES	106R03535
WW METERED	BLACK METERED TONER CARTRIDGE C400/C405 10.5K PAGES	106R03536
WW METERED	YELLOW METERED TONER CARTRIDGE C400/C405 8K PAGES	106R03537
WW METERED	CYAN METERED TONER CARTRIDGE C400/C405 8K PAGES	106R03538
WW METERED	MAGENTA METERED TONER CARTRIDGE C400/C405 8K PAGES	106R03539
DRUM CARTRIDGE KIT C400/C405	DRUM CARTRIDGE KIT FOR THE PHASER 6600, WORKCENTRE 6605/6655, VERSALINK C400/C405, 60K PAGES	108R01121
WASTE CARTRIDGE C400/C405	WASTE CARTRIDGE FOR THE PHASER 6600, WORKCENTRE 6605/6655, VERSALINK C400/C405, 30K PAGES	108R01124

*Average standard pages. Declared Yield in accordance with ISO/IEC 19798. Yield will vary based on image, area coverage and print mode.

Installation Preparation

This section is key to clearly state Xerox/Partner and the customer roles and responsibilities and necessary actions.

Responsibility Matrix

Action	Customer	Xerox/Partner
Ensure adequate space and power to install system	X	
Ensure Site survey is completed and the size requirements are communicated to the customer.		X
Unpack system / components	X	
Install system hardware	X	
Connect all System Components prior to powering up the system	X	
Ensure network configuration	X	
Confirm network integrity	X	
Acquire and install client software including print drivers	X	
Run initial software diagnostics when directed	X	
Monitor and adjust as required	X	
Load any additional fonts	X	
Order and replace Customer Replaceable Units as needed.	X	
Provide Help Line support		X
Provide spared parts		X

Installation Planning

C400 Install Space:

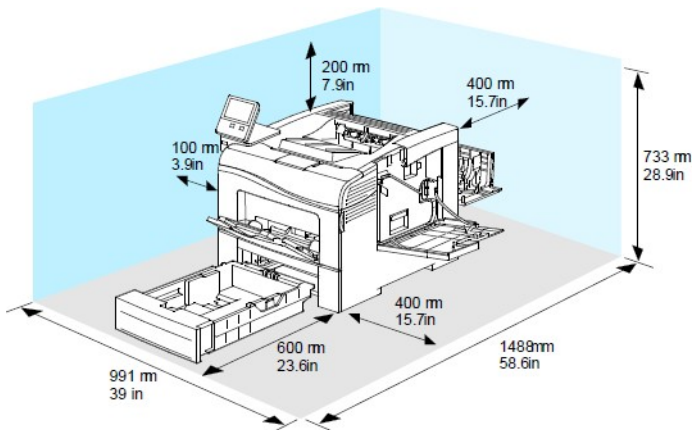

C405 Install Space:

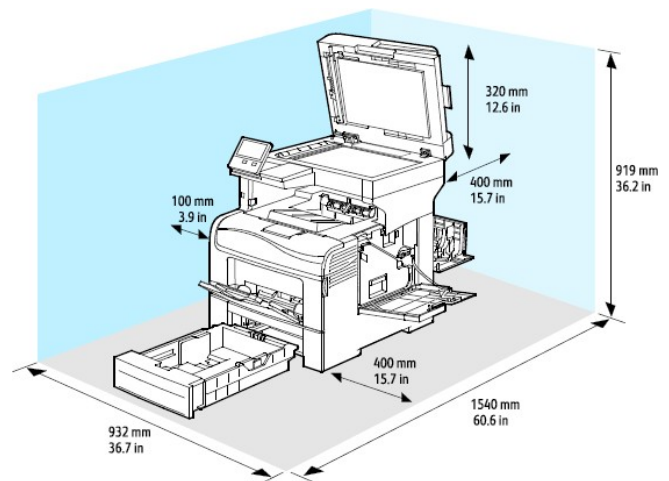

Installation Considerations

Physical delivery is performed by a Xerox authorized common carrier, such as UPS or Xerox carrier. The customer is responsible for un-boxing, setup, connecting and configuring the equipment on their network. The products require a two person lift based on the weight of the products. Customer to provide a table or desk capable of supporting the weight of the equipment. For hallway installations, the customer is to independently review and consider any applicable federal, state, local or other codes and requirements related to emergency egress in the area of installation.

Electrical requirements and space requirements must be satisfied before the equipment is delivered.

3 Appendix

Customer expectations agreement

I have reviewed and understand the product expectations and installation preparation requirements, as referenced in this CEIG document: (Signatures Required)

Customer _____

Xerox/Partner Sales Representative _____

Xerox/Partner Analyst Representative _____

Xerox/Partner Service Representative _____