



SERVICE GUIDE

# Lisa® Water Steam Sterilizer







# **Lisa<sup>®</sup> Water Steam Sterilizer**

## **Service Guide**

## Copyright

© 20%A-dec Inc. All Rights Reserved.

2601 Crestview Drive, Newberg, OR 97132 Printed in USA.

A-dec, Inc. makes no warranty of any kind with regard to this material, including, but not limited to, the implied warranties of merchantability and fitness for a particular purpose. A-dec, Inc. shall not be held liable for any errors contained herein or any consequential or other damages concerning the furnishing, performance or use of this material. The information in this document is subject to change without notice. If you find any problems in the documentation, please report them to us in writing. A-dec, Inc. does not warrant that this document is error-free.

No part of this document may be copied, reproduced, altered, or -transmitted in any form or by any means, electronic or mechanical, including photocopying, recording, or by any information storage and retrieval system, without prior written permission from A-dec Inc.

## Trademarks

A-dec, A-dec logo, A-dec 500, Cascade, Cascade Master Series, Century Plus, Continental, Decade, ICX, Performer, Preference, Preference Collection, Preference ICC, and Radius are registered trademarks in the U.S. Patent and Trademark office.

ICV and Preference Slimline are also a trademark of A-dec Inc.

All other products or services mentioned in this document are covered by the trademarks, service marks, or product names as designated by the companies that market those products.

Lisa is a registered trademark by W&H in the U.S. Patent and Trademark office.

# Lisa Sterilizer Service Guide

---

## Product Identification Symbols



Recognized by Underwriters Laboratories Inc. with respect to electric shock, fire and mechanical hazards only in accordance with UL 60601-1 (2601-1) and under mutual recognition agreement with CAN/CSA C22.2, No. 601.1.



UL listed to UL 61010A-1, BS

EN 61010-2-010 and Canadian (CAN/CSA C22.2, No. 1010.1-92) safety standards.



Classified by Underwriters Laboratories Inc. with respect to electric shock, fire and mechanical hazards only in accordance with UL 60601-1 (2601-1) and under mutual recognition agreement with CAN/CSA C22.2, No. 601.1.



Conforms to applicable European Directives (refer to Declaration of Conformity).



Protective earth (ground).



Functional earth (ground).



Attention, consult accompanying documents.



TYPE B APPLIED PART.



Class II equipment.



Caution: Metal surfaces can be hot during and following the dry cycle.

### **Warranty**

A-dec warrants all products in this catalog against defects in material or workmanship for one year from time of delivery. A-dec's sole obligation under the warranty is to provide parts for the repair, or at its option, to provide the replacement product (excluding labor). The buyer shall have no other remedy. All special, incidental and coincidental damages are excluded.

Written notice of breach of warranty must be given to A-dec within the warranty period. The warranty does not cover damage resulting from improper installation or maintenance, accident or misuse. The warranty does not cover damage resulting from the use of cleaning, disinfecting or sterilization chemicals and processes. The warranty also does not cover light bulbs. Failure to follow instructions provided in the A-dec owner's guides (operation and maintenance instructions) may void the warranty.

A-dec warrants A-dec dental chair cylinders, both lift and tilt, for ten years from the date of purchase of the chair or the cylinder. This warranty is retroactive to A-dec chair cylinders already in the field. The warranty covers chair cylinders A-dec finds to have manufacturing related irregularities. Stool cylinders are covered under A-dec's one-year warranty.

No other warranties as to merchantability or otherwise are made.

# **Lisa Sterilizer Service Guide**

---

## Information Sources

There are a number of other documents in the A-dec document set.

### Genuine A-dec Service Parts Catalog

The *Genuine A-dec Service Parts Catalog* (85.5000.00) provides part number and ordering information for A-dec serviceable parts. This catalog details service parts for current products and products which are no longer manufactured, but are still in use.

### A-dec Illustrated Parts Breakdown

The *Illustrated Parts Breakdown* (85.0851.00) contains fully exploded parts for Excellence, Decade and Cascade delivery systems. Part numbers and descriptions are provided for all parts that are available for sale.

### A-dec Service Guides

The A-dec Service Guides contain flow diagrams for wiring and plumbing, exploded parts drawings for assembling product and calling out part numbers, plus step-by-step troubleshooting for common problems. The guides are great resources for product adjustment and maintenance information.

### OrderNet

OrderNet is a simple, convenient, online ordering system that is available 24 hours a day, 7 days a week. Use OrderNet to place quick orders for service parts or to configure product and prepare proposals. A-dec emails acknowledgements as soon as you place the order.

## Getting Support

### Contacting Customer Service

If you have a question that has not been answered in this document, please contact the customer service number for your area. Contact information for each customer service region is as follows.

Support is available for all areas from our websites.

General website: [www.a-dec.com](http://www.a-dec.com)

Partner Resources website: [www.a-dec.biz](http://www.a-dec.biz)

### U.S. and Canada

2601 Crestview Drive  
Newberg, Oregon 97132, USA

Telephone: 1.800.547.1883 within USA/Canada

FAX: 1.503.547.0276



# Lisa Sterilizer Service Guide

---

## Table of Contents

Section 1 - About the Lisa Sterilizer .....	1
Characteristics .....	1
Cycle Performance .....	2
Class B Test .....	4
Recording Examples .....	5
Drying .....	5
Cycle Description .....	6
2CS System - Condensation Collecting System .....	24
Technical Specifications .....	25
Section 2 - Maintenance .....	27
User Maintenance .....	27
Maintenance Program .....	27
Cleaning the Door Seal .....	28
Cleaning the Chamber, Trays and Tray Holder .....	28
Cleaning External Components .....	28
Replacing the Filter .....	28
Cleaning the Main Water Tank .....	29
Replacing the Door Seal .....	30
Service Checklist .....	31
Section 3 - Exploded Views & Circuit Diagrams .....	33
Exploded Views .....	33
Accessories .....	33
External Parts (1 of 2) .....	34
External Parts (2 of 2) .....	35
Door Complete .....	36
Water Tank/Facade .....	38
Right Side .....	39
Left Side .....	40
Rear Side (1 of 2) .....	41
Rear Side (2 of 2) .....	42
Top Side .....	43
Door Locking System .....	44
EV2/EV4/2CS Collector Subset (54.0027.00) .....	45
EV1/EV3 Subset (54.0028.00) .....	46
EV5/Filter Subset (54.0090.00) .....	47
CPU Board Fuses .....	48
Diagrams .....	49
Electrical Circuit Diagram .....	49
Hydraulic Circuit Diagram (1 of 2) .....	50
Hydraulic Circuit Diagram (2 of 2) .....	51
Section 4 - Testing Prior to Repair .....	53
Vacuum Test .....	53
Bowie & Dick Test .....	54
Accessing the Diagnostic Screens .....	56
Screens 1 and 2 .....	57
Screen 3 .....	57
Accessing Screen 4 .....	59
Loop Cycles Function .....	59

# Lisa Sterilizer Service Guide

Loop Select Function .....	59
Clear Counter Function.....	60
Active Cycle Function .....	61
Gas/Test Function .....	61
Rev. Osmosis Function.....	61
Section 5 – Troubleshooting.....	63
Alarm Classification .....	63
01 Power Supply .....	65
02 Aesthetic Concerns.....	66
03 Printer *.....	67
Printer Types .....	67
Configuring the Printer.....	68
04 Sterilization concerns.....	69
05 Drying Problems .....	70
EN 13060 : Dryness Test Procedure.....	71
EN 13060 "Small Steam Sterilizer Standard" Drying Tolerance Definitions.....	71
Load Preparation (from Owner’s Manual - Annex 2).....	71
06 Condenser Subassembly .....	73
07 Water Tanks .....	74
08 Touchscreen .....	75
09 CPU Board.....	76
10 Sterilization Chamber .....	77
20 Steam Generator .....	82
30 Vacuum Pump.....	84
40 Water Pump.....	87
50 Door Locking System.....	88
60 Electro-Valves .....	91
70 Distilled/De-Mineralized Water.....	92
Preparation of the Load (from User Manual Annex 2).....	92
Water Quality (EN13060 Annex E).....	93
Section 6 – Repair Procedures.....	95
How to Use the Repair Procedures.....	96
Procedure 1 – Replace Cover.....	97
Procedure 2 – Replace Composite Door Cover .....	97
Procedure 3 – Replace Door.....	98
Procedure 4 – Replace Composite Fascia.....	99
Procedure 5 – Replace Touchscreen .....	100
Procedure 7 – Replace Door Seal (replace new type with new type).....	101
Procedure 8 – Replace Vacuum Pump .....	101
Procedure 9 – Replace Water Tank.....	102
Procedure 10 – Replace Door Locking Motor.....	102
Procedure 11 – Replace Door Locking Encoder Board .....	103
Procedure 12 – Replace Mains Filter Pack .....	104
Procedure 13 – Remove Rear Housing Plate.....	104
Procedure 14 – Replace Steam Generator .....	105
Procedure 15 – Replace Steam Generator Heating Element.....	106
Procedure 16 – Replace Water Pump .....	106
Procedure 17 – Replace CPU Board.....	107
Procedure 18 – Replace Printer Interface .....	107
Procedure 19 – Replace Pressure Safety Valves Housing.....	108
Procedure 20 – Replace EV2-EV4 Subset .....	109
Procedure 21 – Replace EV5 Subset.....	110

# Lisa Sterilizer Service Guide

---

Procedure 22 – Replace Steam Generator Thermal-Overload .....	111
Procedure 23 – Replace Condenser and Condenser Fan .....	112
Procedure 24 – Replace External Chamber PT100 Sensor .....	113
Procedure 25 – Replace Data (DT x.x) and Program (EU x.x) EPROM .....	113
Procedure 26 – Replace EV1-EV3 Subset .....	114
Procedure 27 – Replace Vacuum Pump Membrane Kit.....	114
Procedure 28 – Replace EV1-EV3 Coil and Solenoid .....	115
Procedure 29 – Replace Complete Rear Support Frame (including subsets).....	116
Procedure 30 – Replace Composite Service Door .....	117
Procedure 31 – Replace Chamber Internal PT100 T° Sensor .....	117
Procedure 32 – Replace Thermal-Overload.....	118
Procedure 33 – Replace Chamber Heating Element.....	119
Procedure 34 – Replace Vacuum Pump Silencer .....	120
Procedure 35 – Replace/ Adjust Water Pump One-Way Valve Spring .....	120
Procedure 36 – Add/Replace Fascia/Cover Seal .....	121
Procedure 37 – Clean Chamber Outlet Filter .....	122
Procedure 38 – Clean EV5 Subset Filter .....	123
Procedure 39 – Replace Steam Generator PT100 Sensor.....	123
Section 7 – Service Layouts .....	125
How to Use the Repair Layouts .....	126
Layout 1 – Remove/Replace Cover.....	127
Layout 2 – Remove/Replace Composite Door Cover.....	129
Layout 3 – Remove/Replace Door .....	130
Layout 4 – Remove/Replace Composite Fascia.....	131
Layout 5 – Remove/Replace Touchscreen .....	132
Layout 7 – Replace Door Seal.....	133
Layout 8 – Remove/Replace Vacuum Pump.....	134
Layout 9 – Replace Water Tank .....	135
Layout 10 – Control Door Locking Motor Consumption .....	137
Layout 12 – Adjust Door/Locking Pin Side .....	138
Layout 13 – Adjust Door/Door Hinge Mount.....	140
Layout 14 – Remove/Replace Door Locking System .....	142
Layout 15 – Remove/Replace Door Locking Switch Board.....	143
Layout 16 – Adjust Door Locking System Switches.....	144
Layout 17 – Remove/Replace Mains Filter Pack.....	145
Layout 18 – Remove/Replace Rear Cover.....	146
Layout 19 – Remove/Replace Steam Generator.....	147
Layout 20 – Replace Steam Generator Heating Element .....	148
Layout 21 – Remove/Replace Water Pump .....	149
Layout 22 – Calibration CPU Board PT100 & Pressure Transducer .....	150
Layout 23 – Remove/Replace CPU Board .....	153
Layout 24 – Remove/Replace Printer Interface.....	154
Layout 25 – Replace Pressure Safety Valves Housing .....	155
Layout 26 – Remove/Replace EV2-EV4 Subset.....	156
Layout 27 – Replace External Chamber PT100 Sensor.....	157
Layout 28 – Replace EV5 Subset .....	158
Layout 29 – Replace Steam Generator Thermal-Overload.....	159
Layout 30 – Replace Condenser and Condenser Fan.....	160
Layout 31 – Replace EPROM.....	162
Layout 32 – Remove/Replace EV1-EV3 Subset.....	163
Layout 33 – Replace Vacuum Pump Diaphragms/Membrane Kit.....	164
Layout 34 – Replace EV1-3 Coil and Solenoid .....	166

# Lisa Sterilizer Service Guide

---

Layout 35 - Remove Rear Support Frame .....	167
Layout 36 - Replace Composite Service Door.....	168
Layout 37 - Replace Chamber Internal PT100 Temperature Sensor.....	169
Layout 38 - Replace Chamber Thermal-Overload Switch .....	170
Layout 39 - Replace Chamber Heating Element .....	171
Layout 40 - Replace Vacuum Pump Silencer.....	173
Layout 41 - Replace/Adjust Water Pump Calibrated Valve Spring .....	175
Layout 42 - Add/Replace Composite Fascia/ Cover Seal.....	176
Layout 43 - Clean Chamber Outlet Filter (Filter 5) .....	177
Layout 44 - Clean EV5 Subset Filter (Filter 4).....	178
Layout 45 - Replace Steam Generator PT100 Sensor .....	179
Layout 46 - Access Lisa MB17 Test Connection for Process Validation.....	180
Layout 47 - Remove/Replace Touchscreen (quick procedure).....	182
Section 8 - Final Control.....	185
General Controls .....	185
Phase Duration Check .....	185
Phase Duration Table .....	185
Sterilization Process Check .....	186
2CS Condensation Collecting System .....	187
T°/P Correlation Table.....	188
Section 9 - Service Tool List.....	189
Conclusion.....	193

# Lisa Sterilizer Service Guide

---

## About this Service Guide

This service guide provides information for repairing and servicing the Lisa sterilizer. Autoclave items are identified, and troubleshooting, replacement and adjustment are described in detail.

Note: Service should be performed only by qualified technicians. Observe all local and country directives related to service and safety norms.

## Symbols Used in This Guide

The following symbols are used to emphasize important safety and operation information.



**WARNING** - identifies danger points or conditions and the correct procedures that must be followed to avoid injury.



**CAUTION** - identifies actions that could damage the device.



**HOT SURFACES** - When handling hot items, take special care to avoid burns.



**COMPONENTS SENSITIVE TO ELECTROSTATIC CHARGES** - MOS/MOSFET components on electronic boards are sensitive to electrostatic charges conducted by the human body; take precautions before handling sensitive components and boards to avoid malfunction.

## Service Sequence

Follow this sequence of actions when a request is received from a user.

- 1 Note the malfunction provided by the user.
- 2 Analyze the problem to find possible cause(s) (see Section 4).
- 3 Before repairing, perform the tests in Section 5 to discover the malfunction.
- 4 The "Procedures Layouts" column of the troubleshooting table will direct you to the repair procedure to follow (in Section 6). The repair procedure will direct you to the service layouts required to perform the repair.
- 5 Perform the final control and tests in Section 8.



## **Section 1 – About the Lisa Sterilizer**

### **Characteristics**

- ▶ Developed, produced and tested according to the European Norm PrEN 13060 for small water steam sterilizers.
- ▶ Totally Class B cycles.
- ▶ Compact sterilizer, without any external tank or connections.
- ▶ Patented «2CS » pneumatic system :
  - Low water consumption: 7 to 12 oz/cycle (.2 to .35 liters/cycle).
  - 8 to 12 cycles without refilling or draining.
  - Quick cycles: 30 minutes (276°F/135.5°C-4 minutes).
  - 5 fractionated pre-vacuum.
  - Pulsed vacuum drying.
- ▶ Independent steam generator.
- ▶ Optimized energy management (0.5 kwh/cycle).  
Maximum absorbed power: 2100 W.
- ▶ Interactive user-friendly touchscreen.
- ▶ Simple to use and safe.
- ▶ Entirely controlled by microprocessor.  
Evolutionary software.
- ▶ Single piece stamped stainless-steel chamber.
- ▶ Reversible tray support: 5 trays horizontal or 3 cassettes horizontal or vertical.
- ▶ Optional printers.
- ▶ Refilling and draining possible during the cycle.
- ▶ Electric double door locking system and parallel positioning of the door gasket.
- ▶ Easy accessibility for service. Test functions available on the touchscreen.
- ▶ Warranty: Up to 2 years or 2000 cycles whichever comes first.

## Cycle Performance

<b>Power</b>	Design Type: Microprocessor-controlled steam sterilizer, (3) Class B cycles MB17 Power Requirements: Single Phase 230 VAC +/- 10% / 50-60 Hz / 10A Power Consumption: Maximum 2100 W Rated Current: 9.2A
<b>External Dimensions</b>	17.5 (W) x 16.1 (H) x 20.5 (D) (inches) 445 (W) x 410 (H) x 520(D) (mm)
Weight Empty	105.8 lb. / 48 kg
Operational Weight	108.0 lb. / 49 kg
<b>Noise Level</b>	
Average	38 dB
Maximum	53 dB
<b>Pressure Chamber</b>	
Capacity	18.0 quarts / 17 liters
Diameter	9.84 in. / 250 mm
Depth	13.77 in. / 350 mm
Maximum Pressure	34.8 psi / 2.4 bar
Maximum Temperature	280 °F / 138 °C
<b>Usable Chamber Space</b>	
Capacity	12.7 quarts / 12 liters
Dimensions	7.67 (W) x 8.07 (H) x 11.81 (D) (inches) 195 (W) x 205 (H) x 300 (D) (mm)
<b>Water Tanks</b>	
Main Capacity	3.7 quarts / 3.5 liters
Used Water Capacity	4.2 quarts / 4.0 liters
<b>Air Vent Filter</b>	0.3 µm
<b>External Connections</b>	The MB17 used water tank can be plumbed to automatically drain with on optional kit.
<b>Data Capture Devices</b>	Custom DP40 dot matrix printer



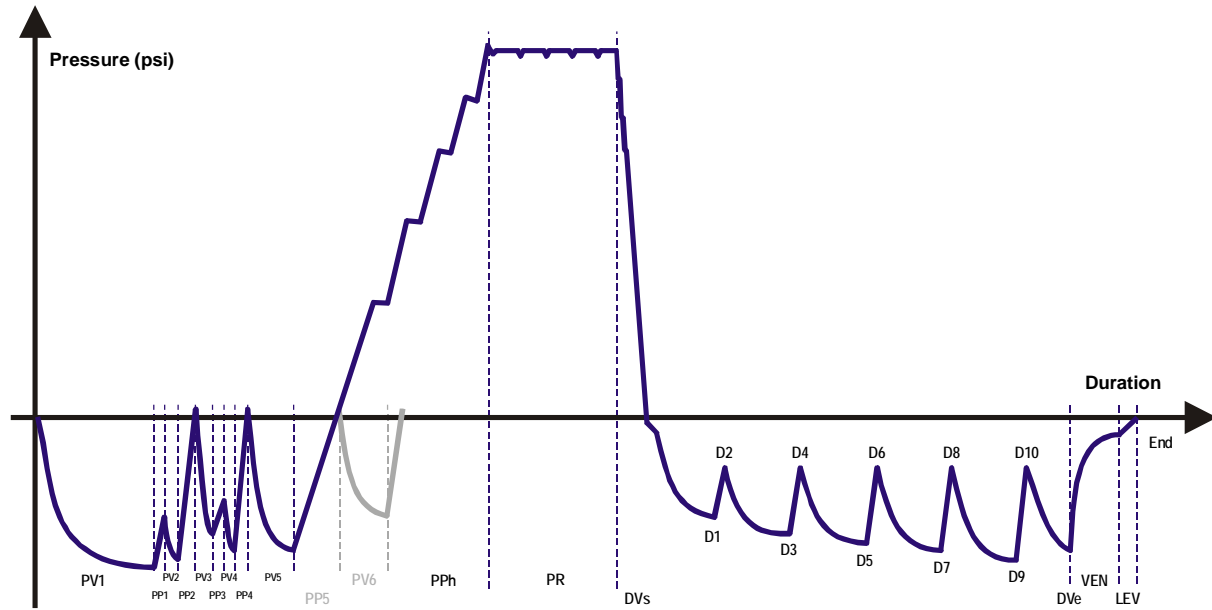

Fractionated pre-vacuum

Plateau time

Pulsed vacuum drying

**Legend:**

PV1..6 : Vacuum pulse

PP1..5 : Pressure pulse







PPh : Pressure pulse and heating

PR : Process

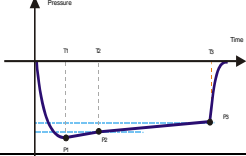
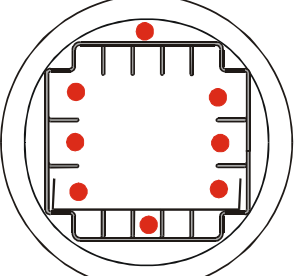
DV : Vacuum drying

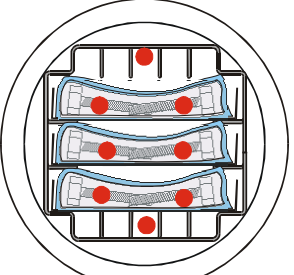
VEN : Ventilation    LEV : Leveling

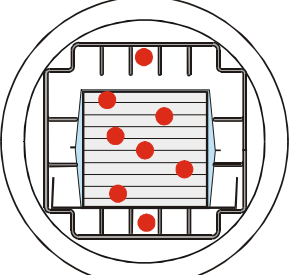
**Class B Test**

<p>Vacuum test (air leakage)</p>	<p><b>P3-P2 &lt; 0.019psi/min</b> <b>10 min</b> (p3 : pressure end/ p2 : pressure start )</p>	
<p>Dynamic Pressure Test</p>	<p>Pressure variation &lt; 145psi/ min (2.42psi/sec.)</p>	
<p>Empty chamber</p>	 	<p>Control of the saturated steam T°/Pressure correlation and in process bands</p>
<p>Full solid products Wrapped</p>	 	<p>Screw M12 x 100 wrapped = 9.9 lbs (4.5 kg) (Max mass declared)</p>
<p>Full porous load (textile) Wrapped</p>	 	<p>80% Usable space = 3.3 lbs (1.5 kg) (Max mass declared)</p>
<p>Dryness test Wrapped loads</p>	<p><b>Solid: <math>\frac{m2-m1}{m1} \times 100 &lt; 0,2\%</math></b> <b>Porous: <math>\frac{m2-m1}{m1} \times 100 &lt; 1\%</math></b> <b>m1</b> (m1 : mass start m2 : mass end )</p>	

### Recording Examples

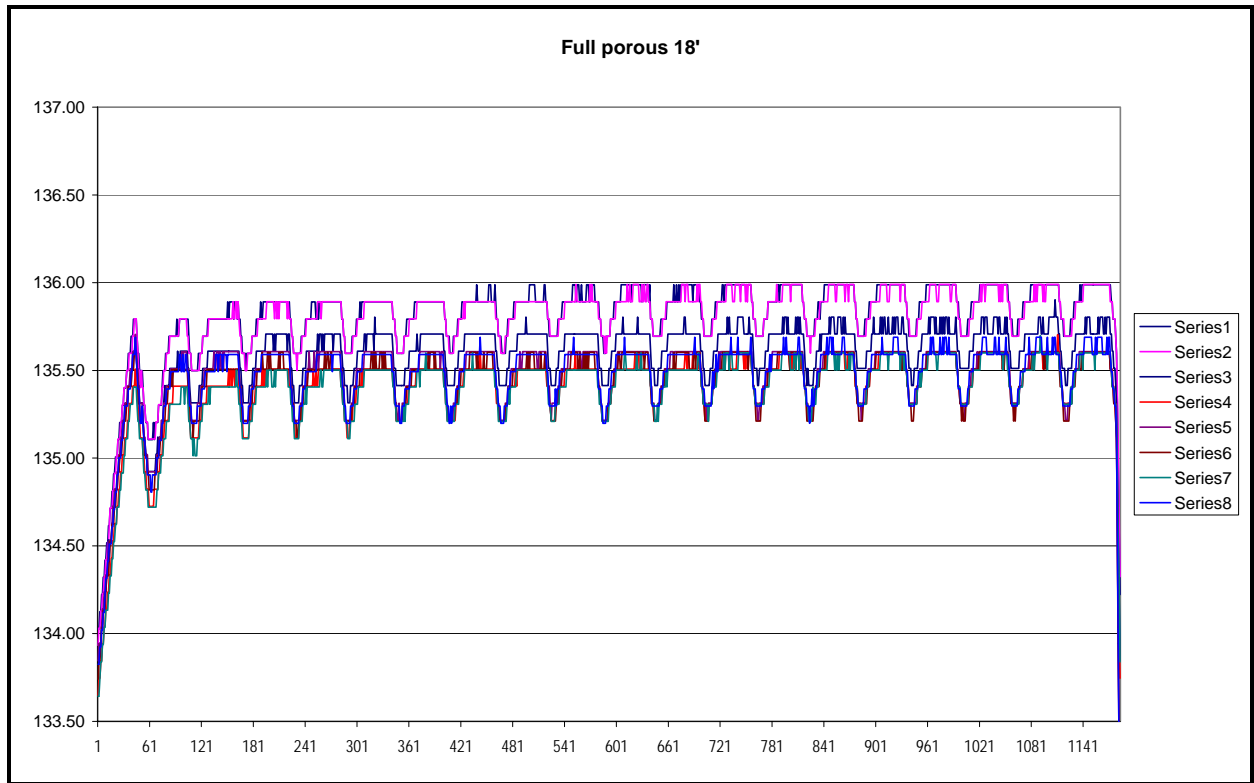

### Drying



Weight Before Sterilization



Weight After Sterilization

**Cycle Description**

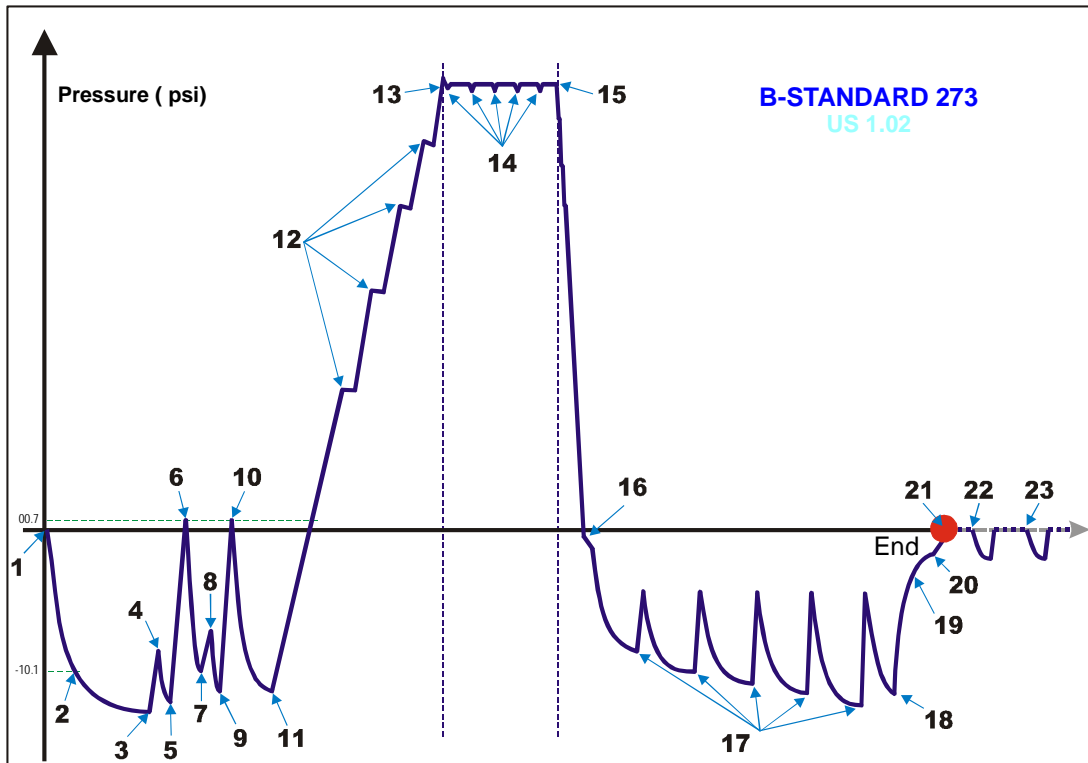
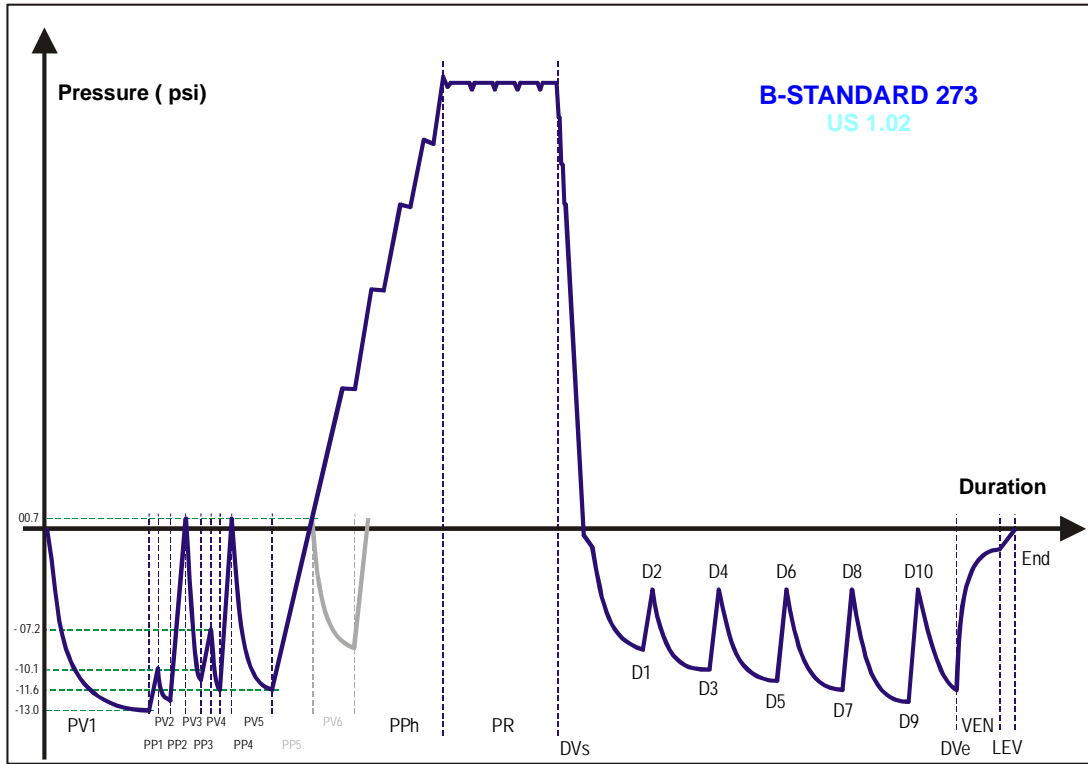

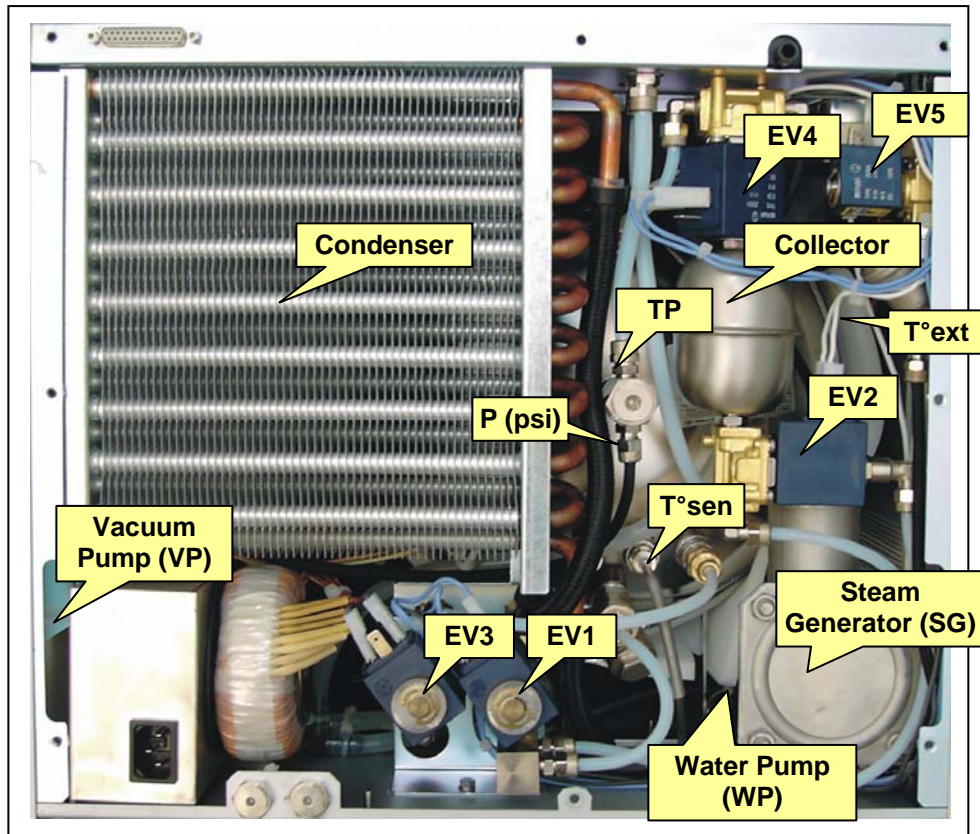
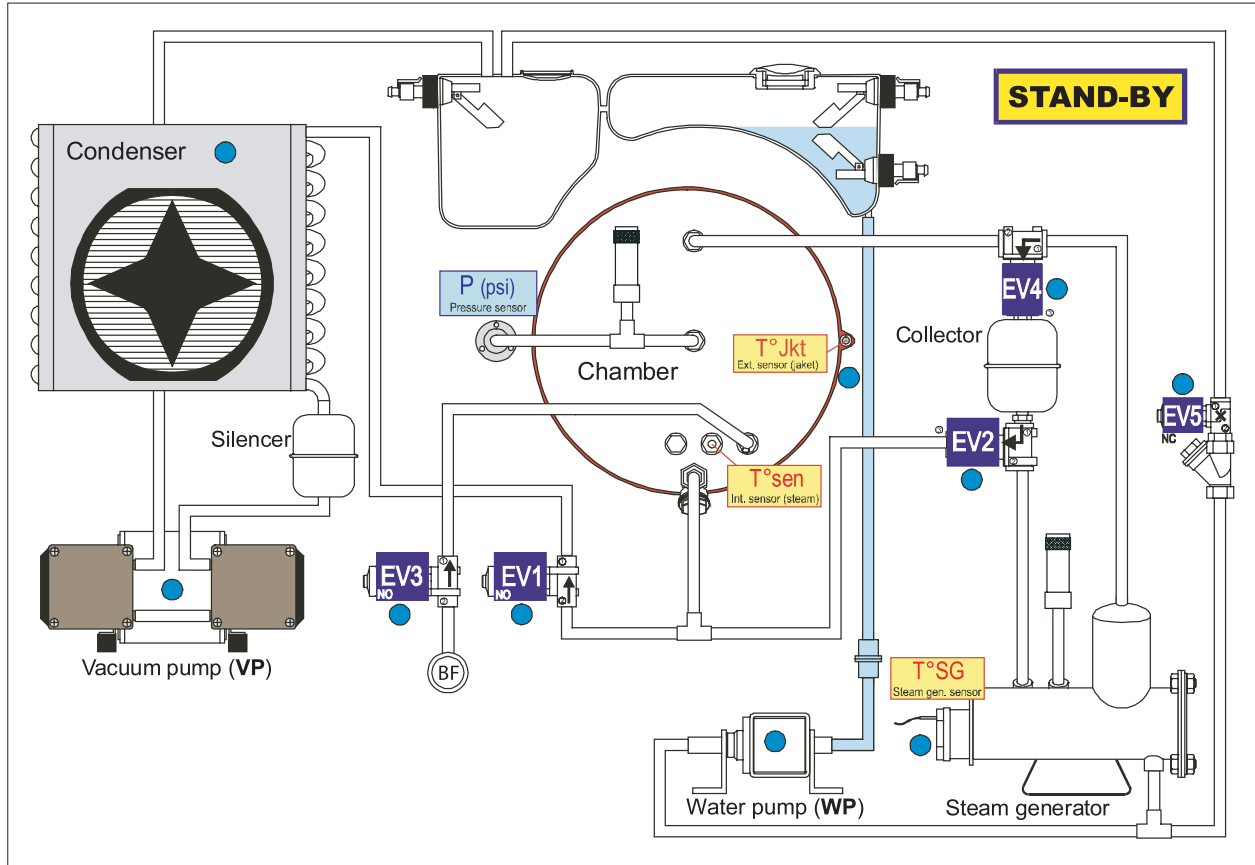

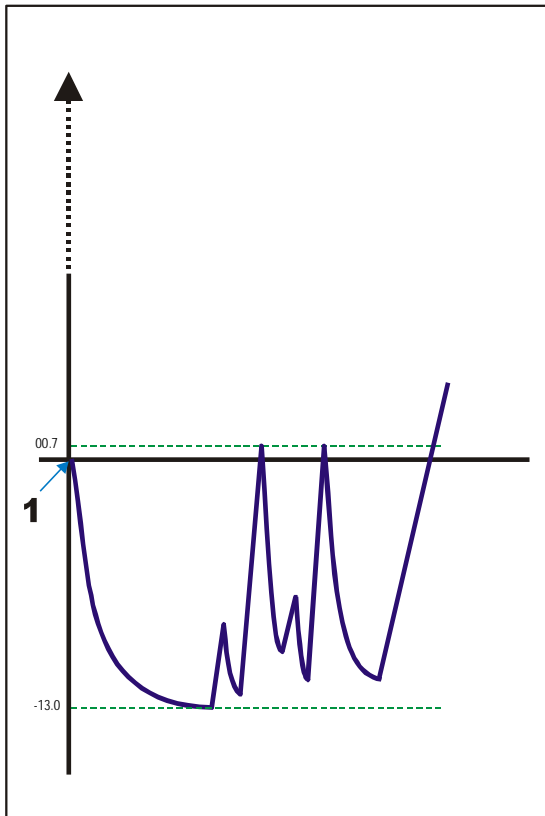
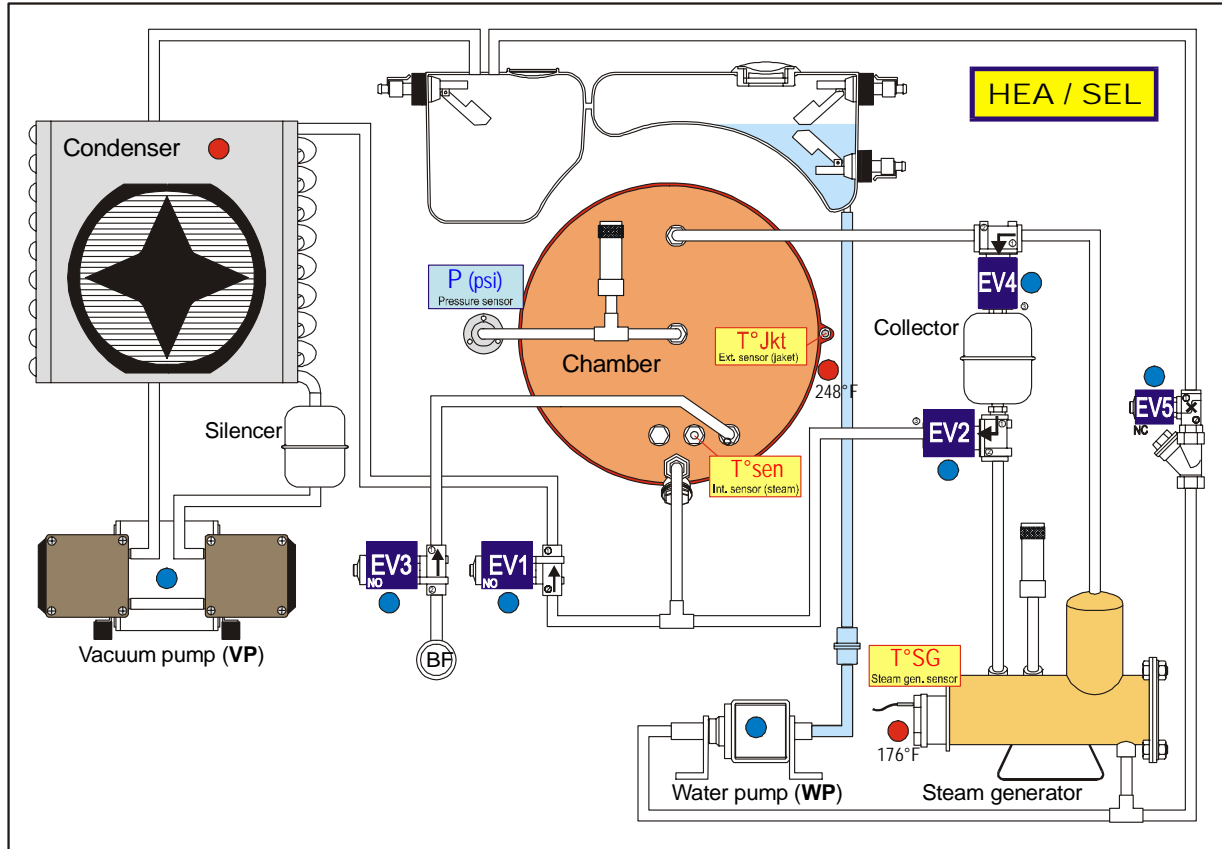

Stages	Actions	Comments
0	STERILIZER POWERED Condenser FAN ON Chamber → 248°F Generator → 176°F	PLEASE SELECT A CYCLE
Maxi. phase duration	After x minutes → automatic shut-off x : setting in "STAND-BY" menu to 30min. 2-4-6 hours or Off (disabled)	

Notes :

---



---



---



---



---

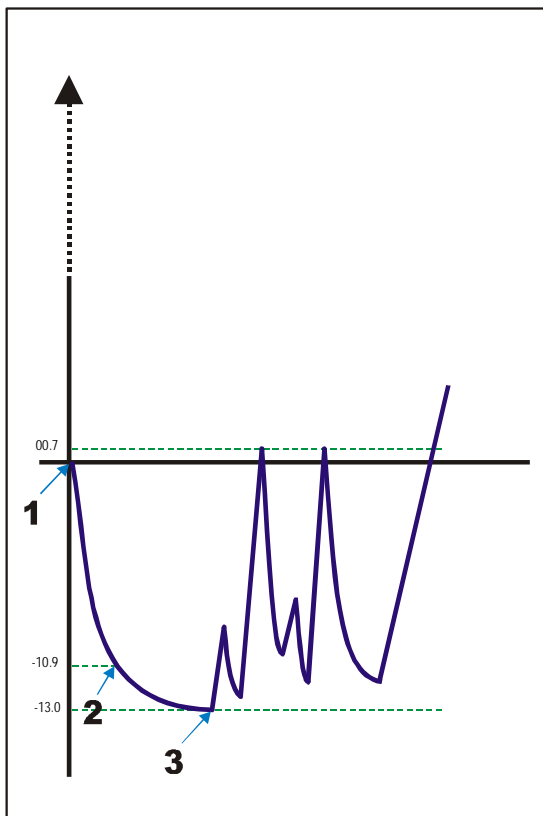
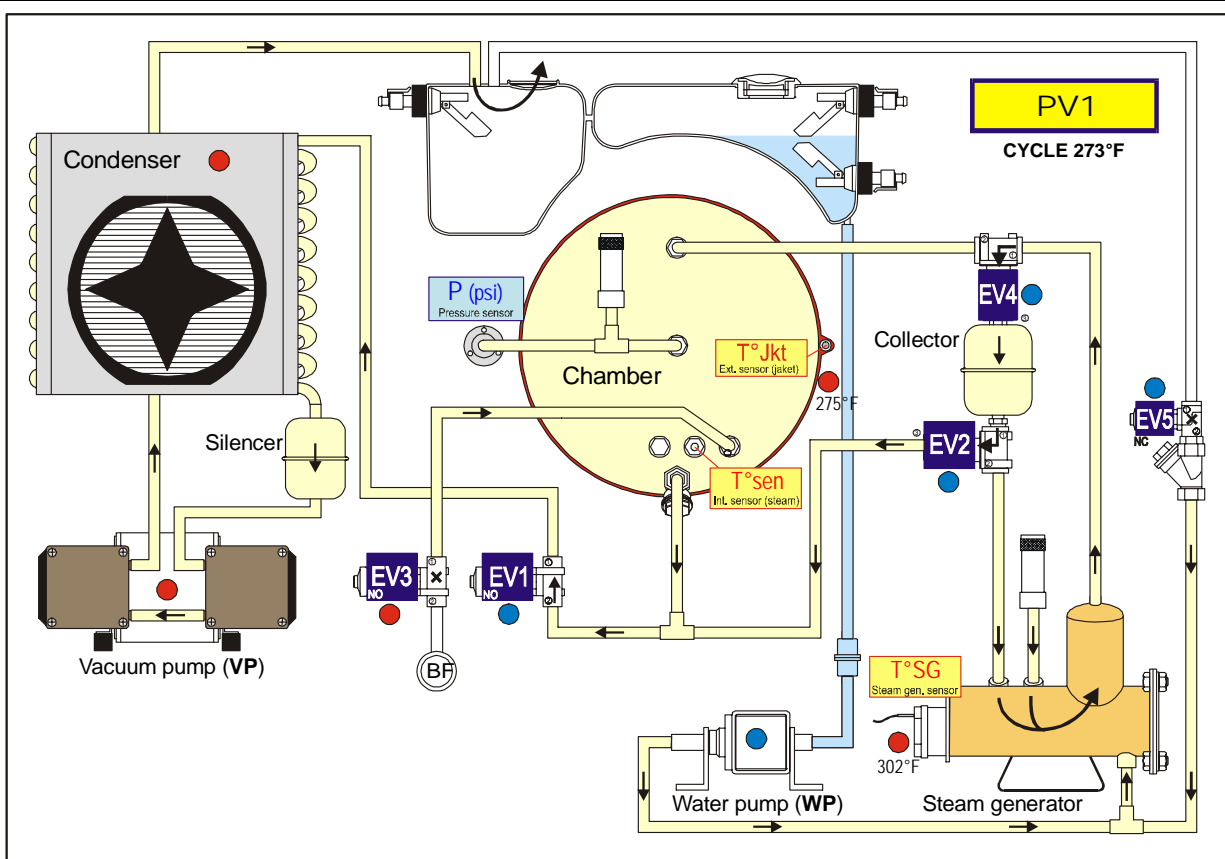

Stages		Actions	Comments
1	Start	VP ON EV3 ON	Beginning of the fractionated pre-vacuum
2	P = -10.8 psi	EV2 ON WP ON → 34"	Water injection into steam generator
3	P = -12.3 psi AND Steam Gener. Temp. ≥ 280.4°F	EV1 ON EV4 ON EV2 OFF	↘ End of PV1 ↗ Start of PP1
Maxi. phase duration		Time out : 6'	

Notes : \_\_\_\_\_  
 \_\_\_\_\_  
 \_\_\_\_\_  
 \_\_\_\_\_

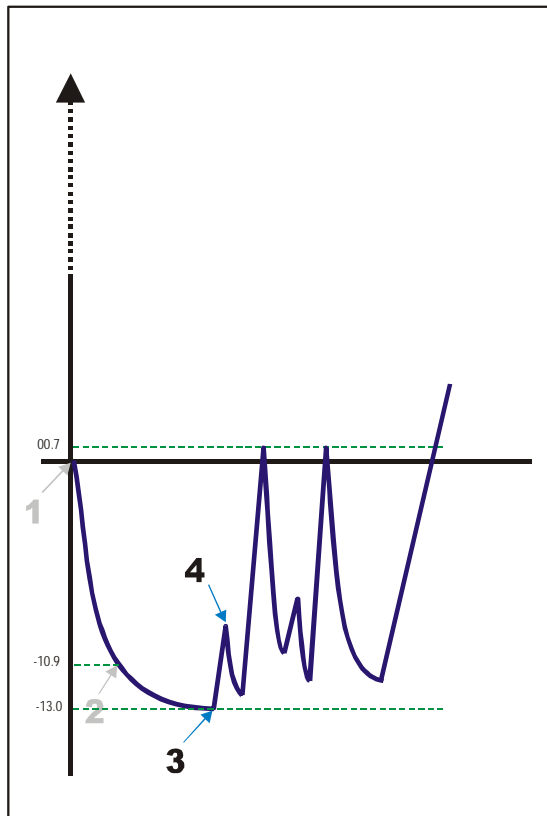
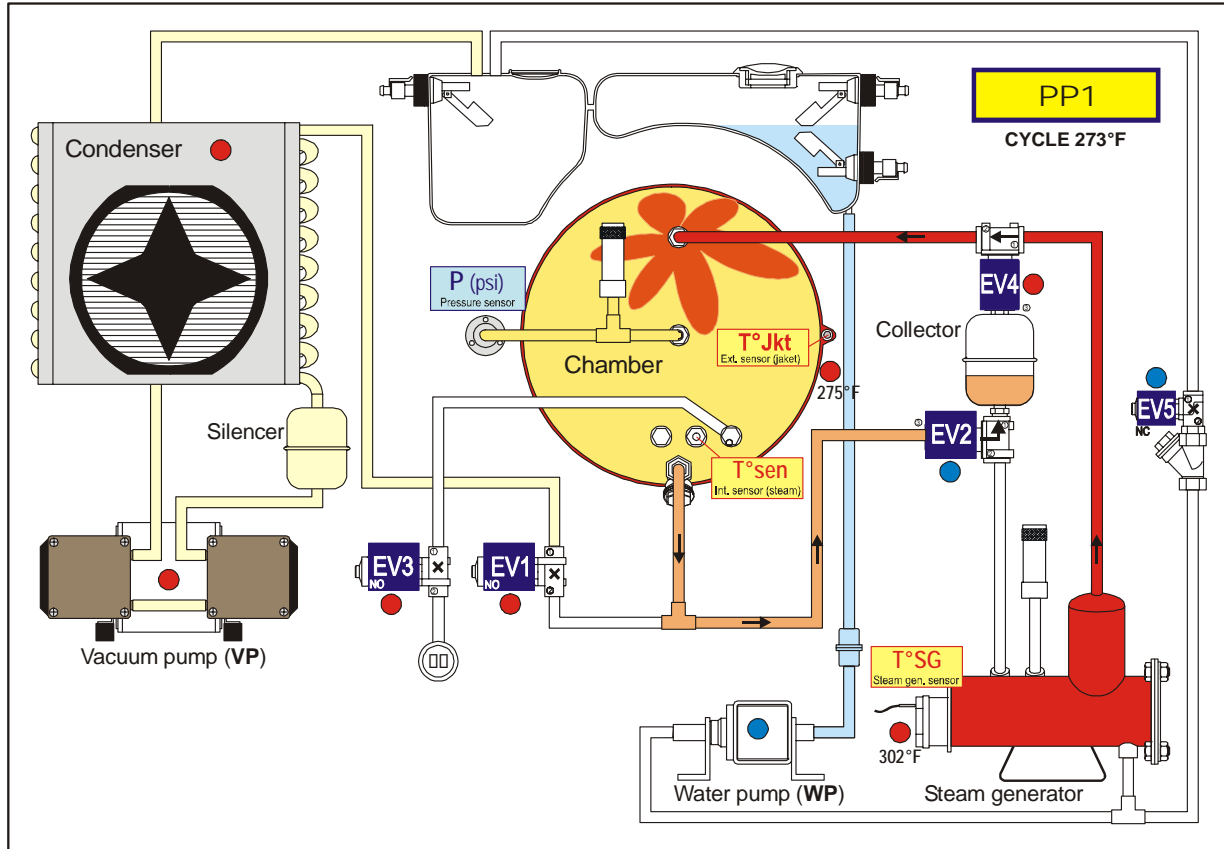

Stages	Actions	Comments	
3	P = -12.3 psi <b>AND</b> Steam Gener. Temp. > 280.4°F	<b>EV1 ON</b> <b>EV4 ON</b> <b>EV2 OFF</b>	↘ End of PV1 ↗ Start of PP1
4	P = -10.1 psi	<b>EV1 OFF</b> <b>EV4 OFF</b> <b>EV2 ON</b>	↘ End of PP1 ↗ Start of PV2
<b>Maxi. phase duration</b>		Time out : 3'	

**Notes :**

---



---



---



---



---



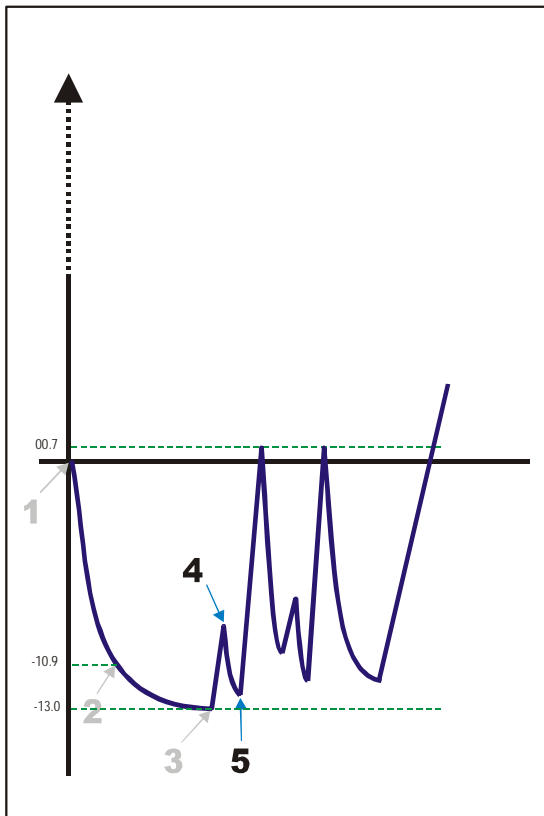
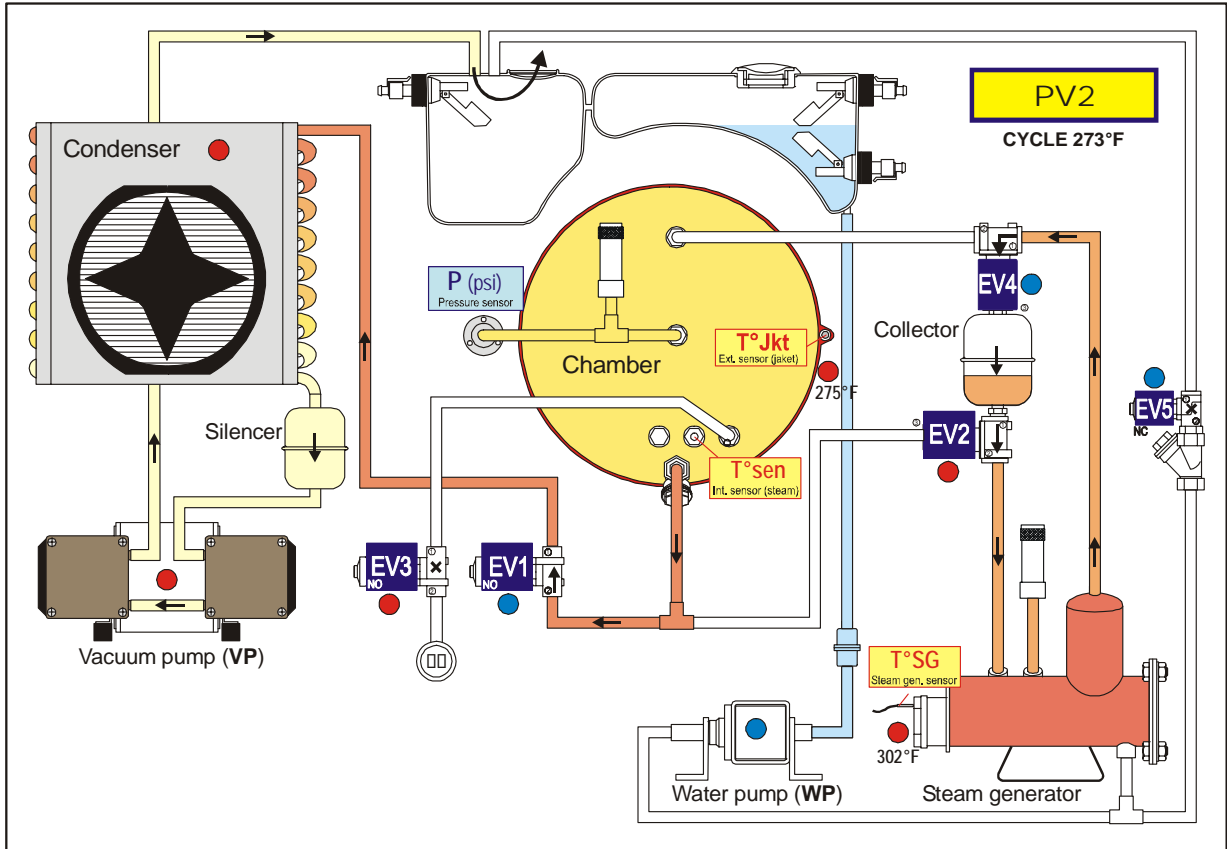

Stages	Actions	Comments
4	P = -10.1 psi EV1 OFF EV4 OFF EV2 ON	↘ End of PP1 ↗ Start of PV2
5	P = -12.3 psi EV1 ON EV4 ON EV2 OFF	↘ End of PV2 ↗ Start of PP2
<b>Maxi. phase duration</b>		Time out : 6'

**Notes :**

---



---



---



---



---

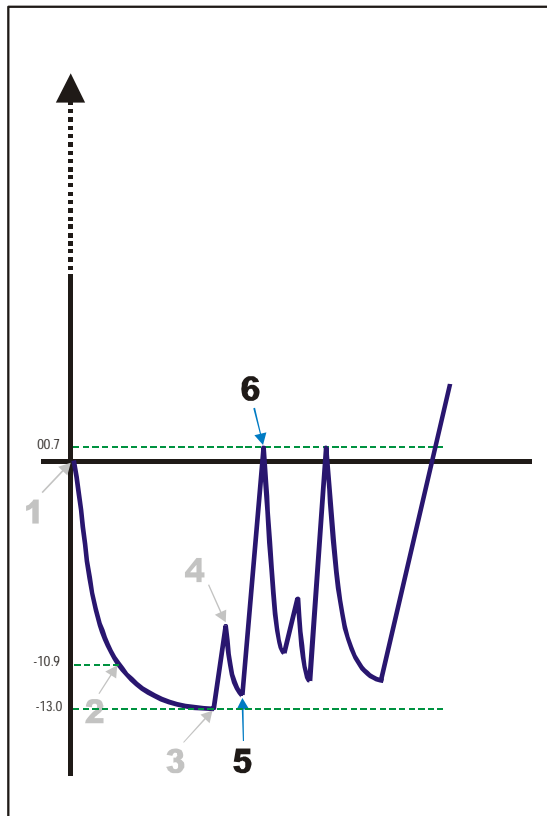
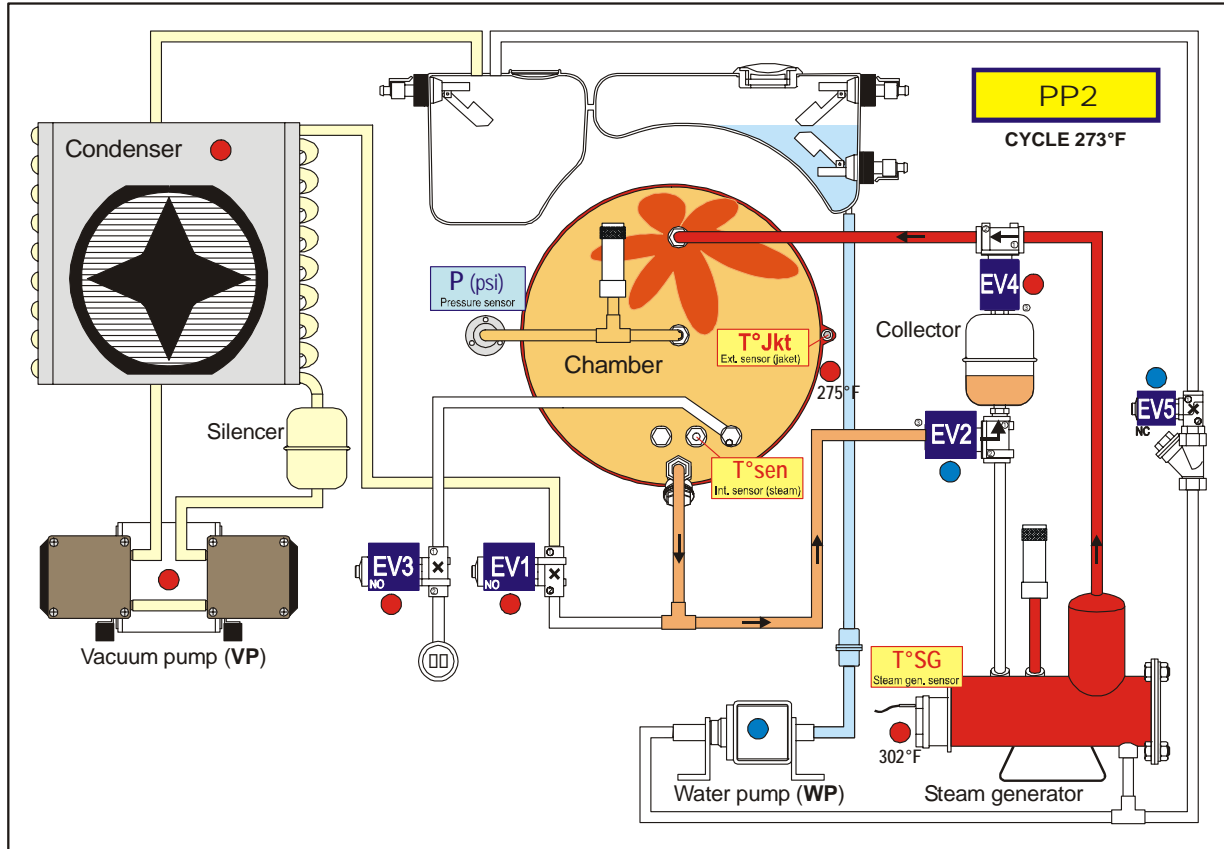

Stages	Actions	Comments
5 P = -12.3 psi	EV1 ON EV4 ON EV2 OFF	↘ End of PV2 ↗ Start of PP2
6 P = 0.7 psi	EV1 OFF EV4 OFF EV2 ON	↘ End of PP2 ↗ Start of PV3
<b>Maxi. phase duration</b>	Time out : 6'	

**Notes :**

---



---



---



---



---

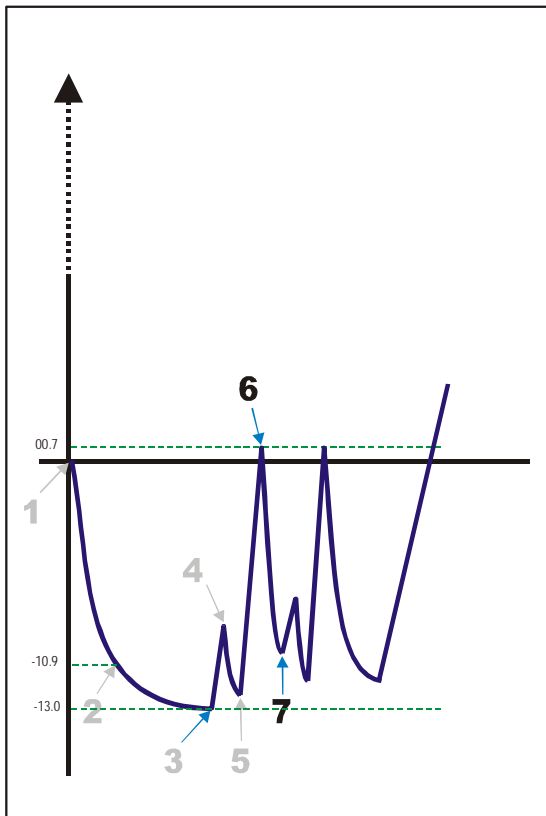
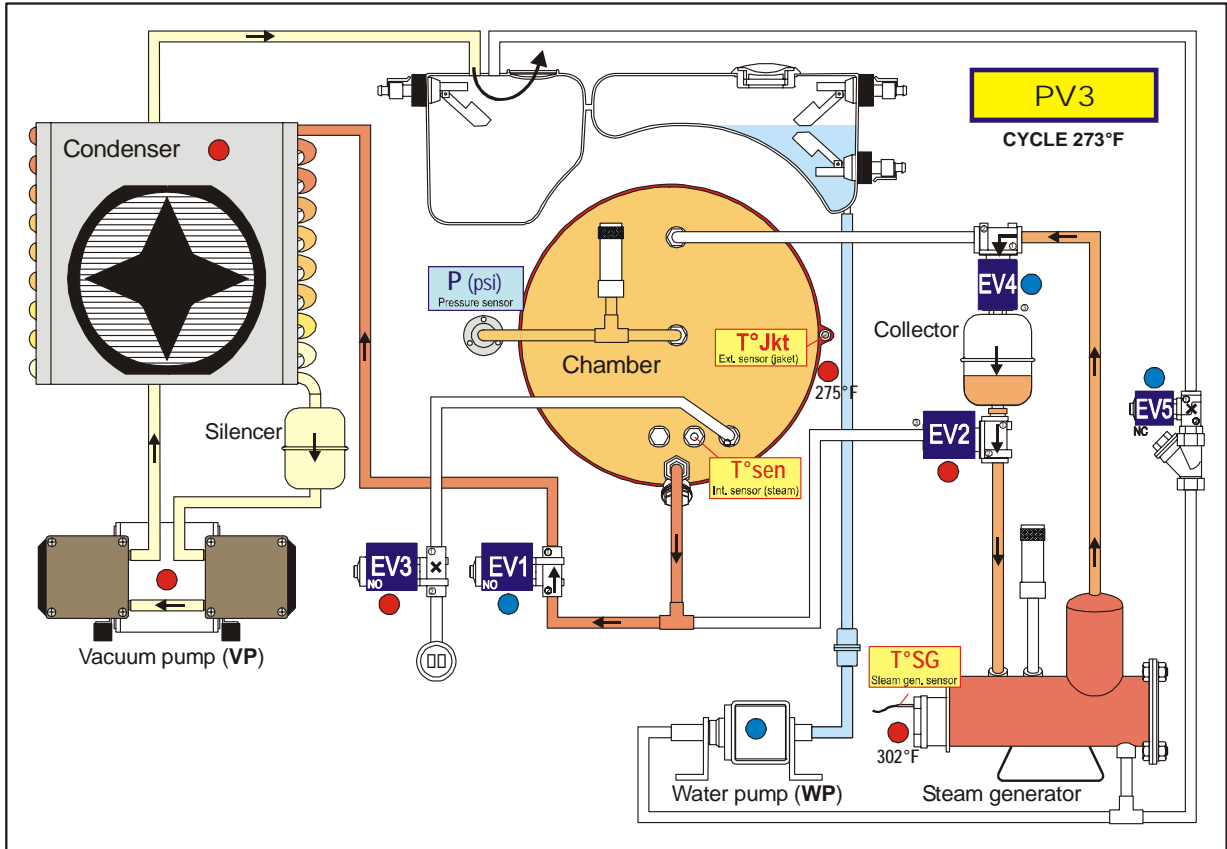

Stages	Actions	Comments
6 P = 0.7 psi	EV1 OFF EV4 OFF EV2 ON	↘ End of PP2 ↗ Start of PV3
7 P = -10.8 psi	EV1 ON EV4 ON EV2 OFF	↘ End of PV3 ↗ Start of PP3
<b>Maxi. phase duration</b>		Time out : 6'

**Notes :**

---



---



---



---



---

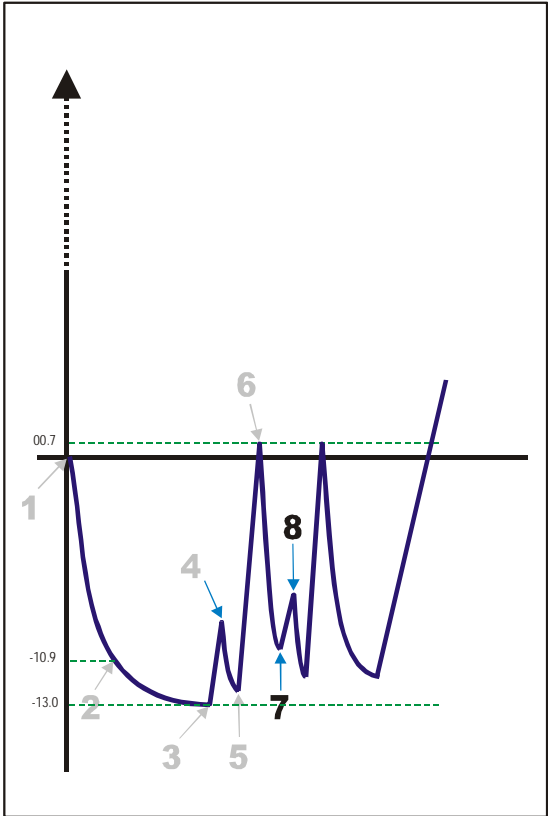
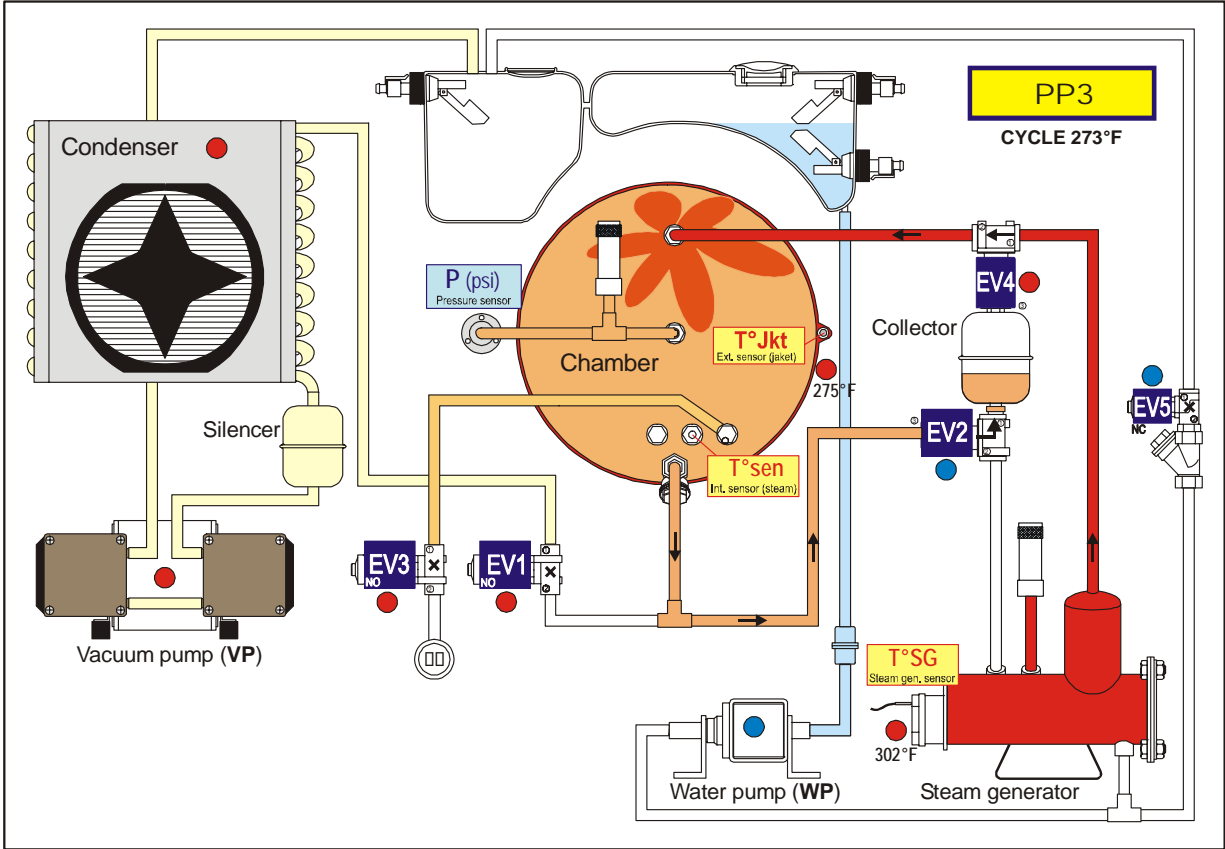

Stages	Actions	Comments
7 P = -10.8 psi	EV1 ON EV4 ON EV2 OFF	↘ End of PV3 ↗ Start of PP3
8 P = -7.2 psi	EV1 OFF EV4 OFF EV2 ON	↘ End of PP3 ↗ Start of PV4
<b>Maxi. phase duration</b>		Time out : 6'

**Notes :**

---



---



---



---



---

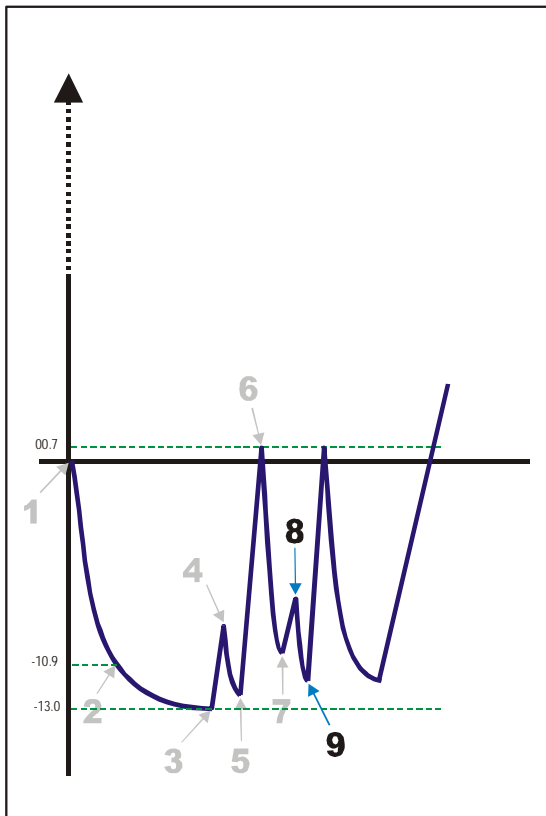
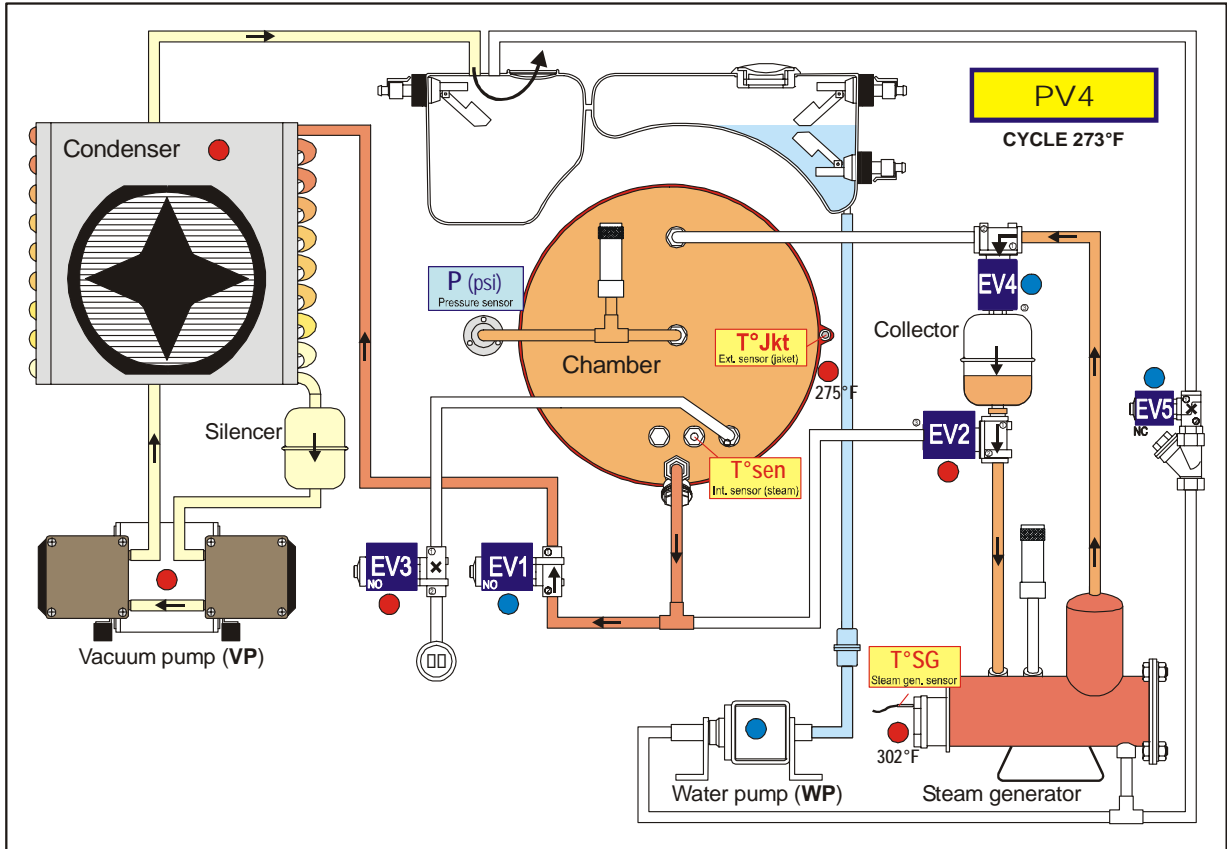

Stages	Actions	Comments
8 P = -7.2 psi	EV1 OFF EV4 OFF EV2 ON	↘ End of PP3 ↗ Start of PV4
9 P = -11.6 psi	EV1 ON EV4 ON EV2 OFF	↘ End of PV4 ↗ Start of PP5
<b>Maxi. phase duration</b>		Time out : 6'

**Notes :**

---



---



---



---



---

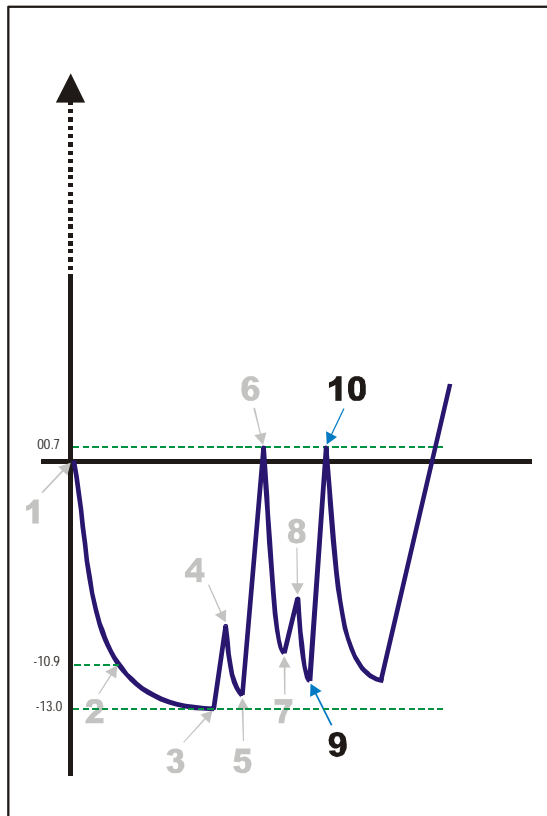
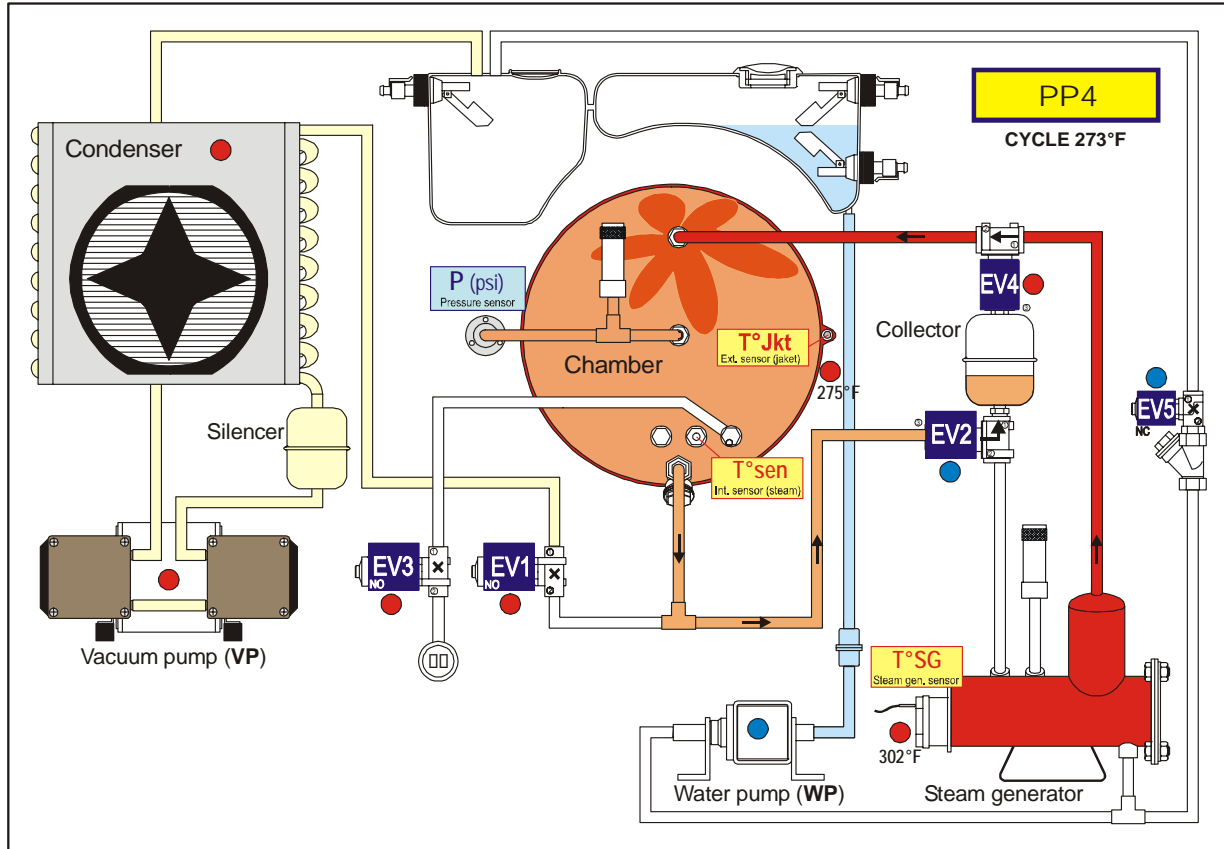

Stages	Actions	Comments
9	P = -11.6 psi EV1 ON EV4 ON EV2 OFF	↘ End of PV4 ↗ Start of PP5
10	P = 0.7 psi EV1 OFF EV4 OFF EV2 ON	↘ End of PP5 ↗ Start of PV5
<b>Maxi. phase duration</b>		Time out : 6'

**Notes :**

---



---



---



---



---

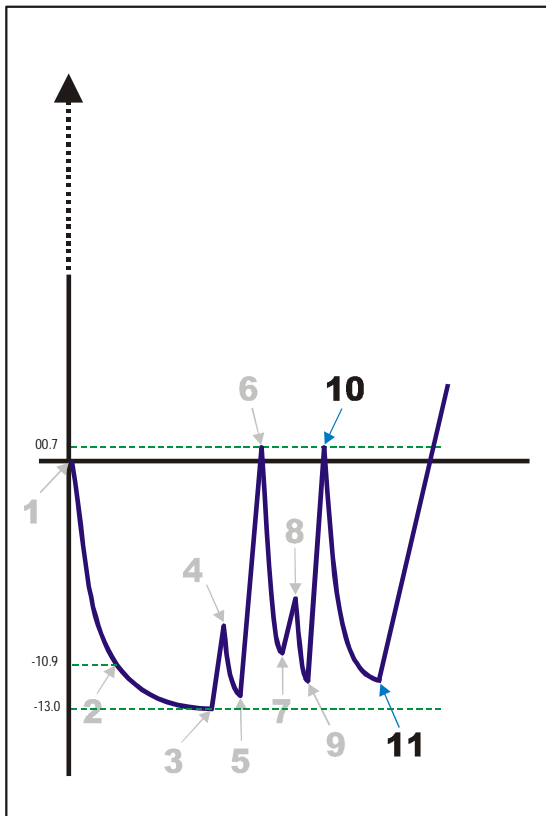
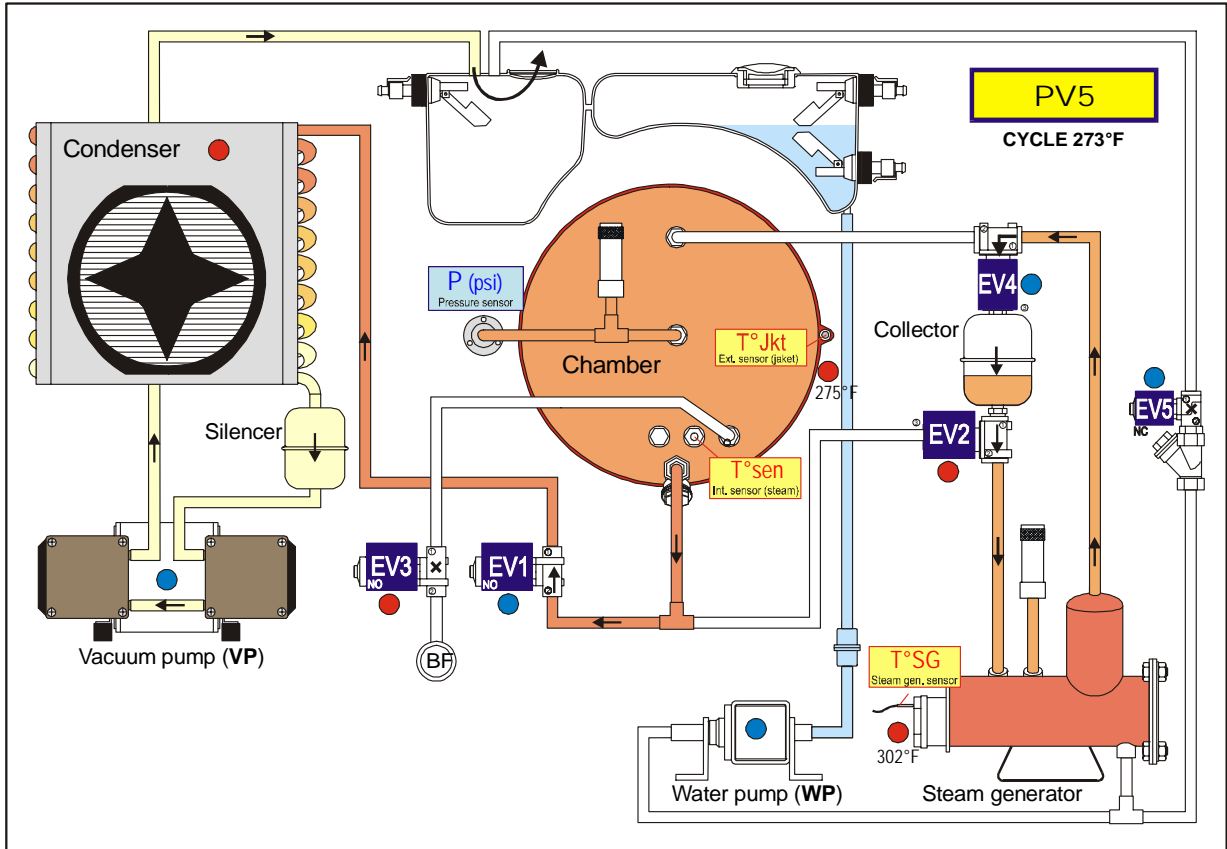

Stages	Actions	Comments
10 P = 0.73 psi	EV1 OFF EV4 OFF EV2 ON	↘ End of PP4 ↗ Start of PV5
11 P = -11.6 psi	VP OFF EV1 ON EV4 ON EV2 OFF	↘ End of PV5 and fraction. vacuum ↗ Start of PPh
Maxi. phase duration		Time out : 6'

Notes :

---



---



---



---



---

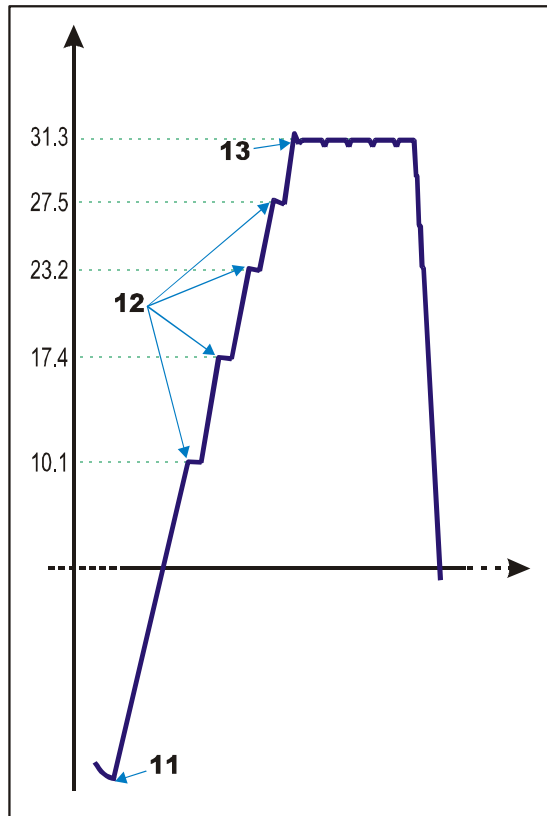
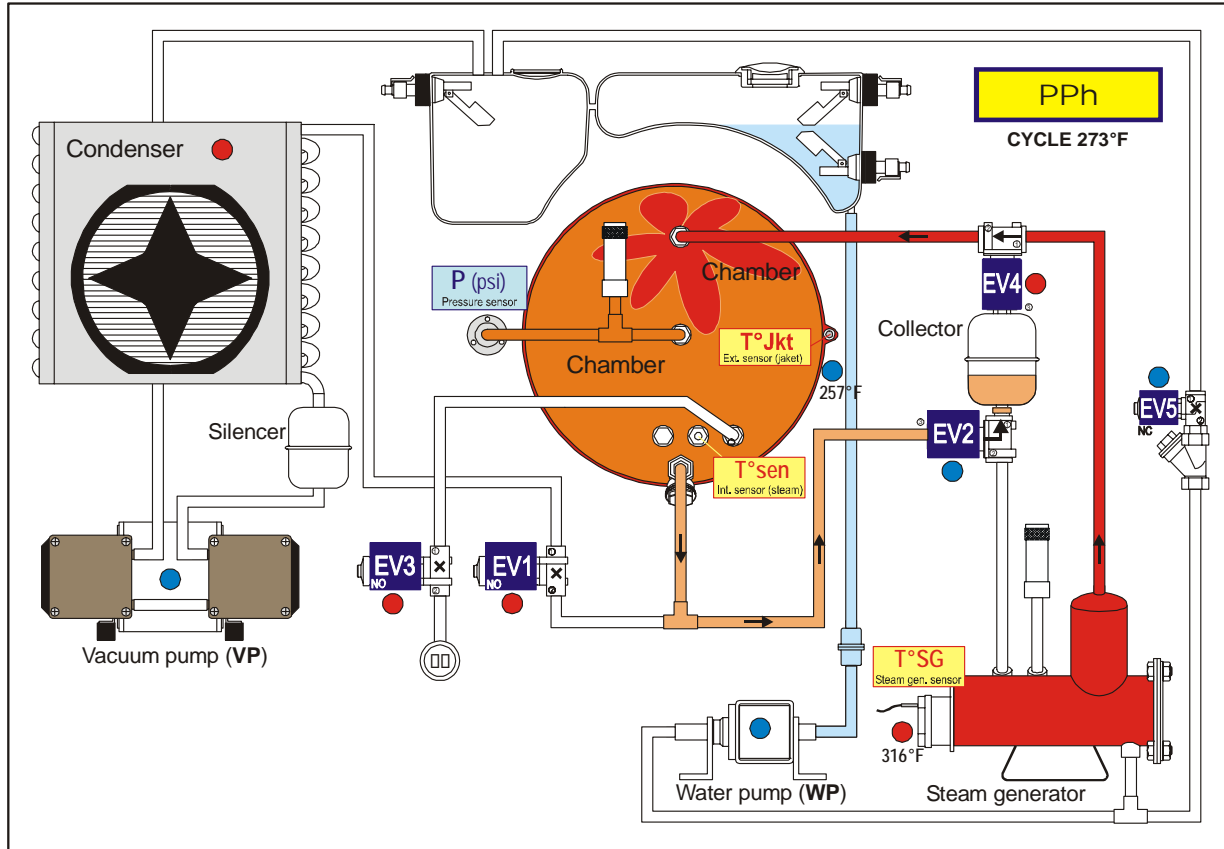

Stages	Actions	Comments
11 P = -11.6 psi	VP OFF EV1 ON EV4 ON EV2 OFF	↘ End of PV5 and fraction. vacuum ↗ Start of PPh
12 P = 10.1 psi P = 17.4 psi P = 23.2 psi P = 27.5 psi	EV4 OFF for 15" EV2 ON for 15"	<b>2CS activated :</b> Coll. condensation discharged into the steam generator
13 P = 31.3 psi	Steam Generator powered/regulated to keep P=31.3 psi	↘ End of PPh ↗ Start of PR Holding time
<b>Maxi. phase duration</b>		20 min. (↗ Alarm A10 if more)

**Notes :**

\_\_\_\_\_

\_\_\_\_\_

\_\_\_\_\_

\_\_\_\_\_

\_\_\_\_\_



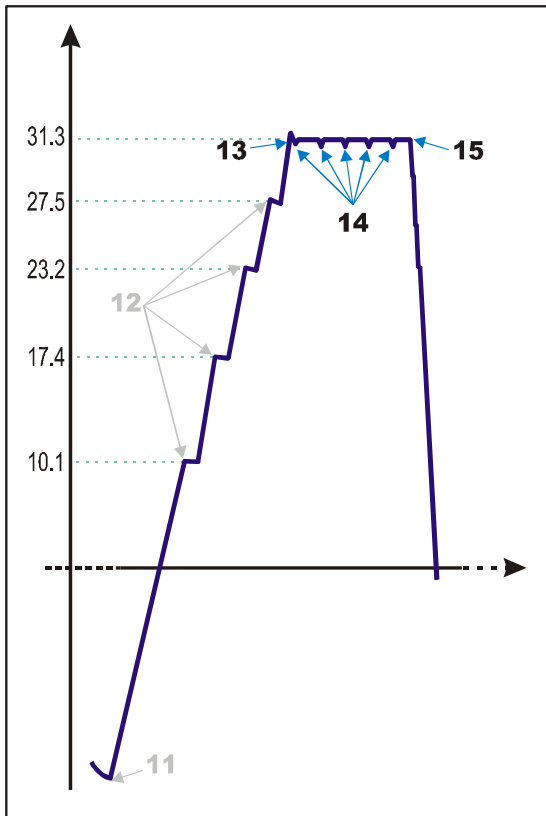
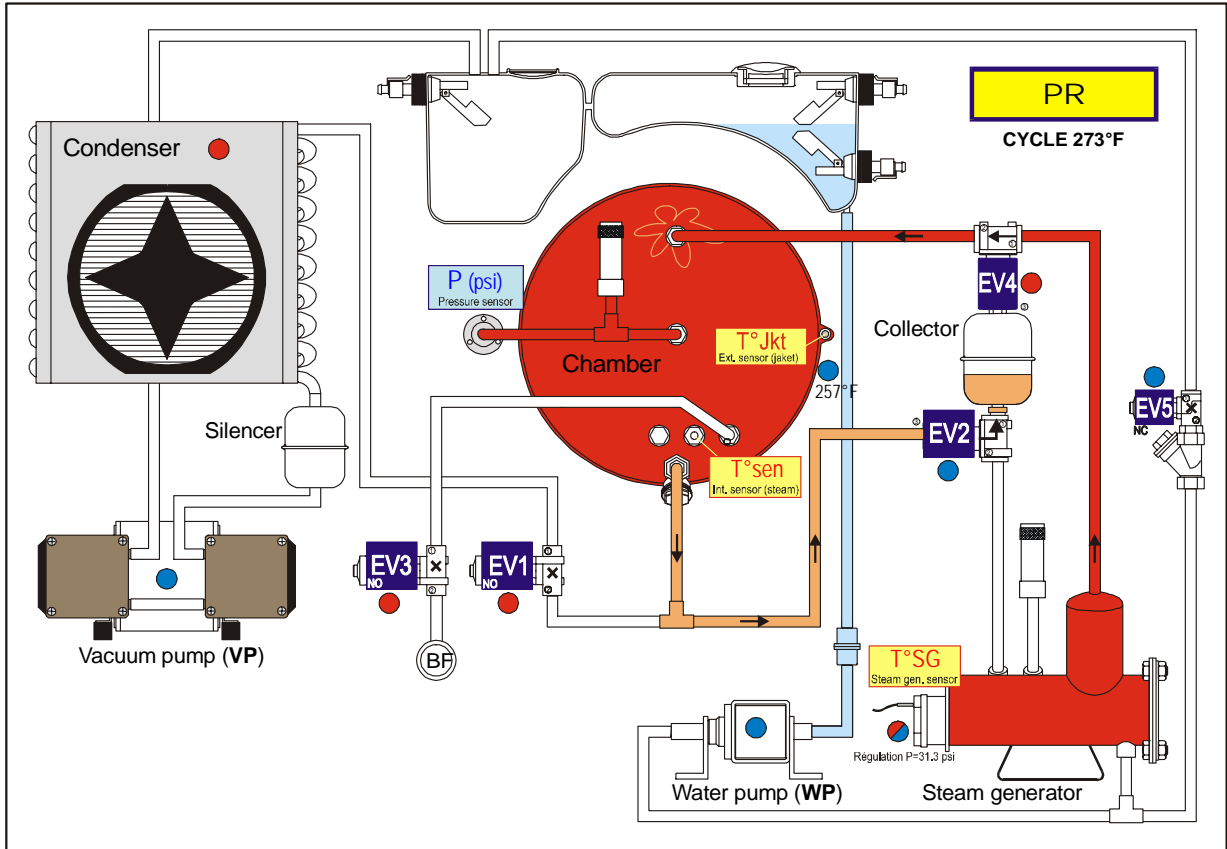

Stages	Actions	Comments
13 P = 31.3 psi	Steam Generator powered/regulated to keep P=31.3 psi	↘ End of PPh ↗ Start of PR Holding time
14 Every 50 sec. IF P > 30.9 psi	EV4 OFF for 6" EV2 ON for 6"	2CS activated : Coll. condensation discharged into the steam generator
15 Holding time = 4 minute	VP ON EV1 OFF EV4 OFF EV2 ON	↘ End of PR ↗ Start of DV Drying phase

Notes :

\_\_\_\_\_

\_\_\_\_\_

\_\_\_\_\_

\_\_\_\_\_

\_\_\_\_\_

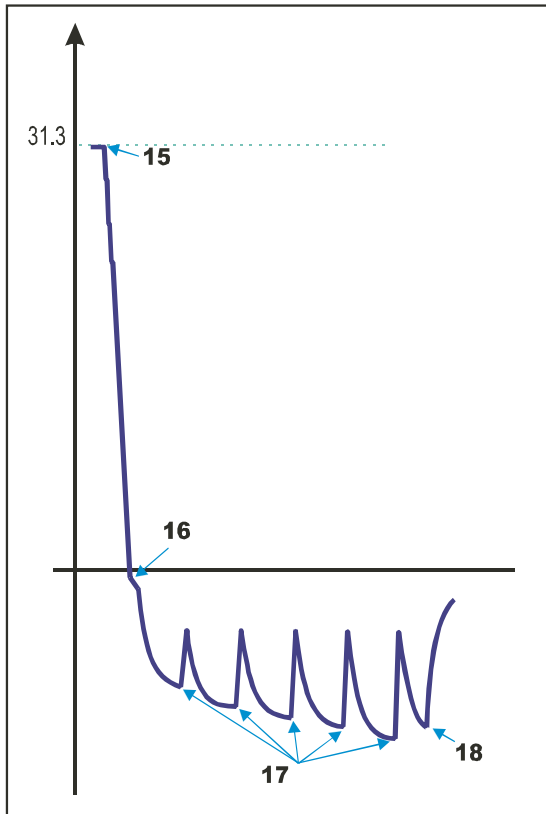
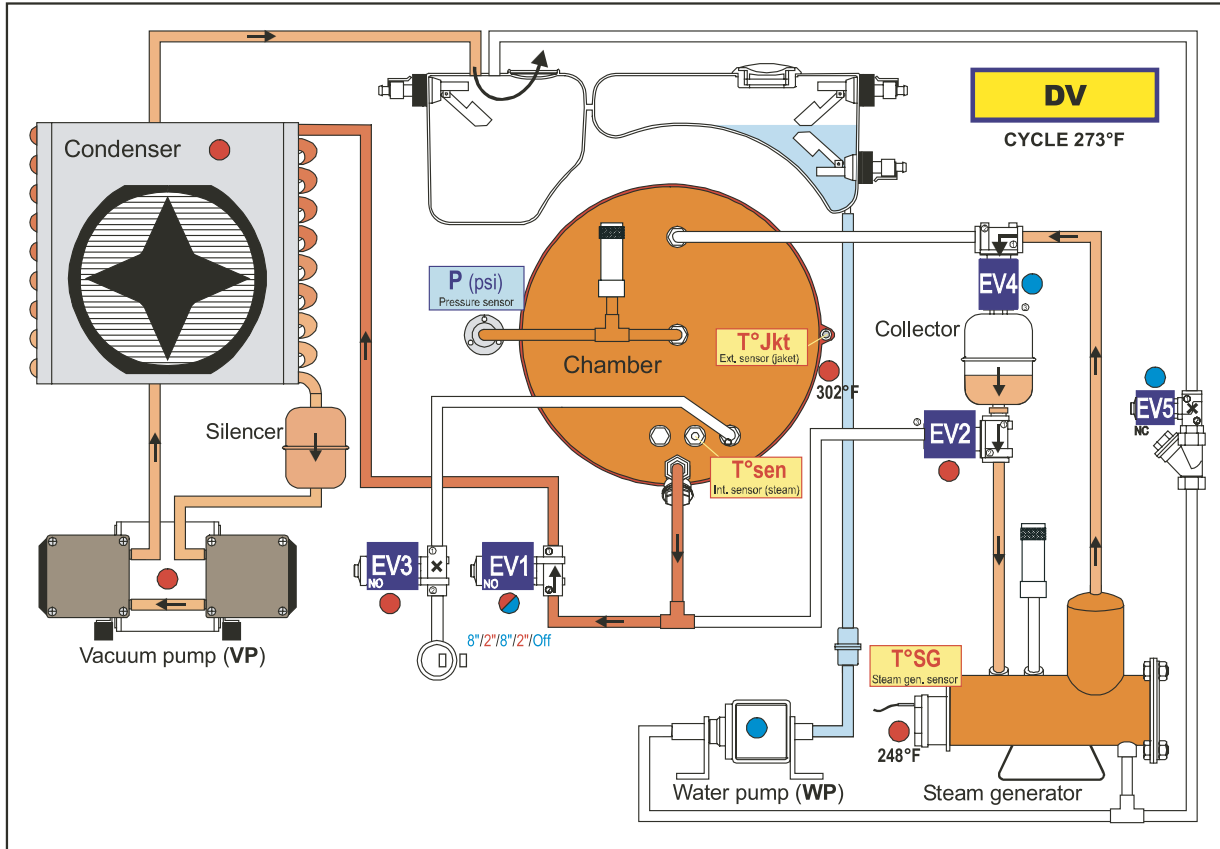

Stages	Actions	Comments
15	VP ON EV1 OFF EV4 OFF EV2 ON	↘ End of PR ↗ Start of DV Vacuum drying
16	EV3 OFF for 20"	Condenser drained
17	Every 3min. EV3 OFF for 10"	Pulsed drying
18	EV3 OFF EV5 ON	↘ End of DV ↗ Start of VEN Ventilation

**Notes :**

---



---



---



---



---

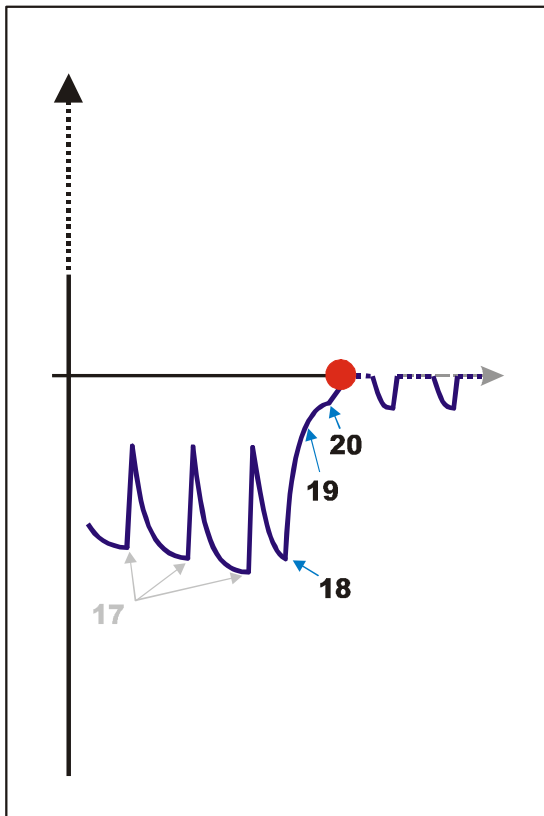
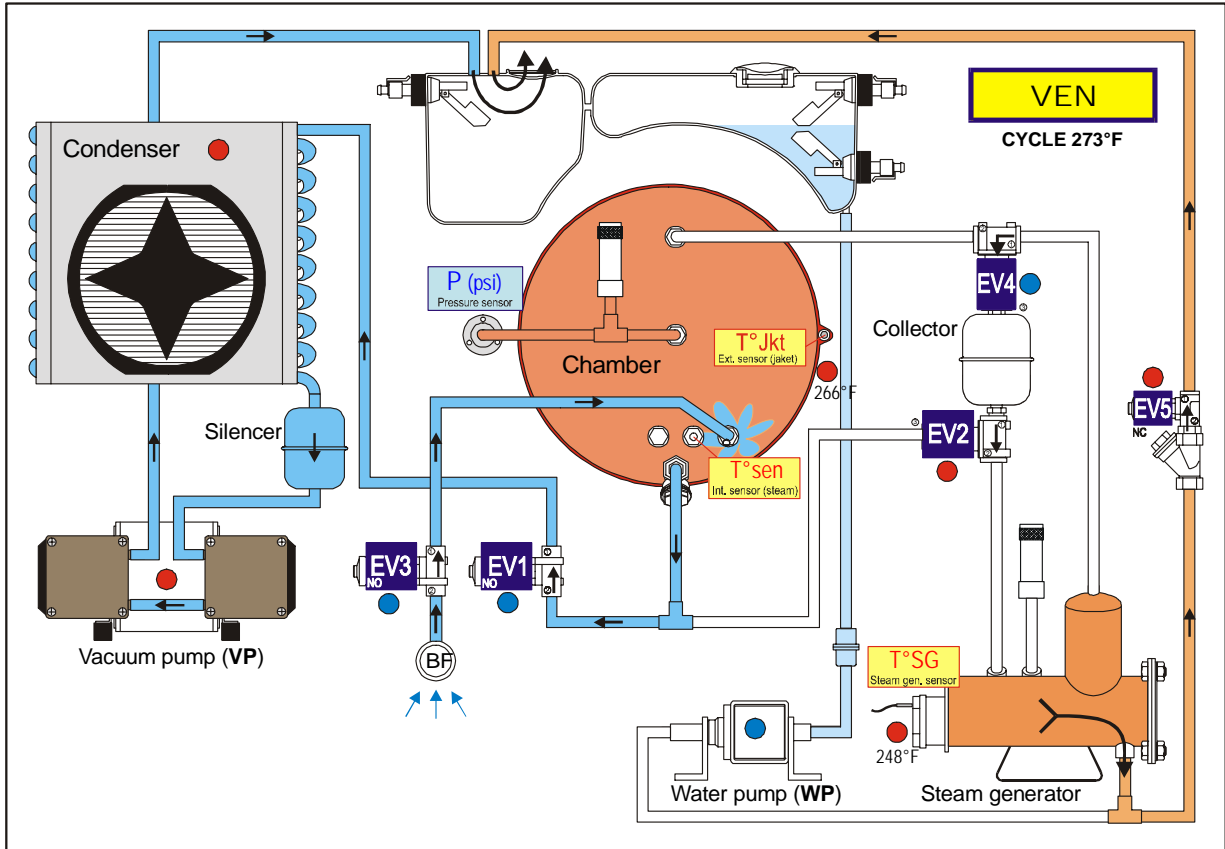

Stages	Actions	Comments
18 DV duration = 14 minutes	EV3 OFF EV5 ON	↘ End of DV ↗ Start of VEN Ventilation
19 VEN duration = 25 sec.	EV5 OFF EV2 OFF	Vacuum in the steam generator
20 VEN duration = 40 sec.	VP OFF	↘ End of VEN ↗ Start of LEV Levelling

Notes :

---



---



---



---



---

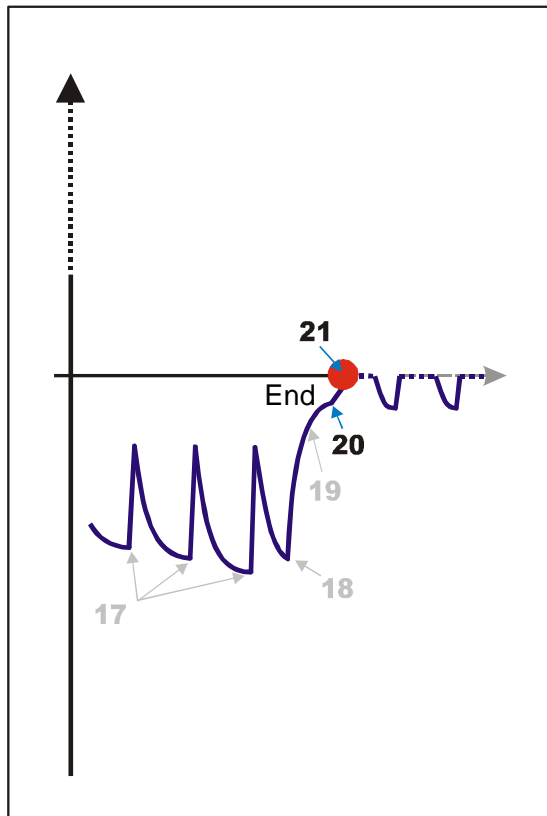
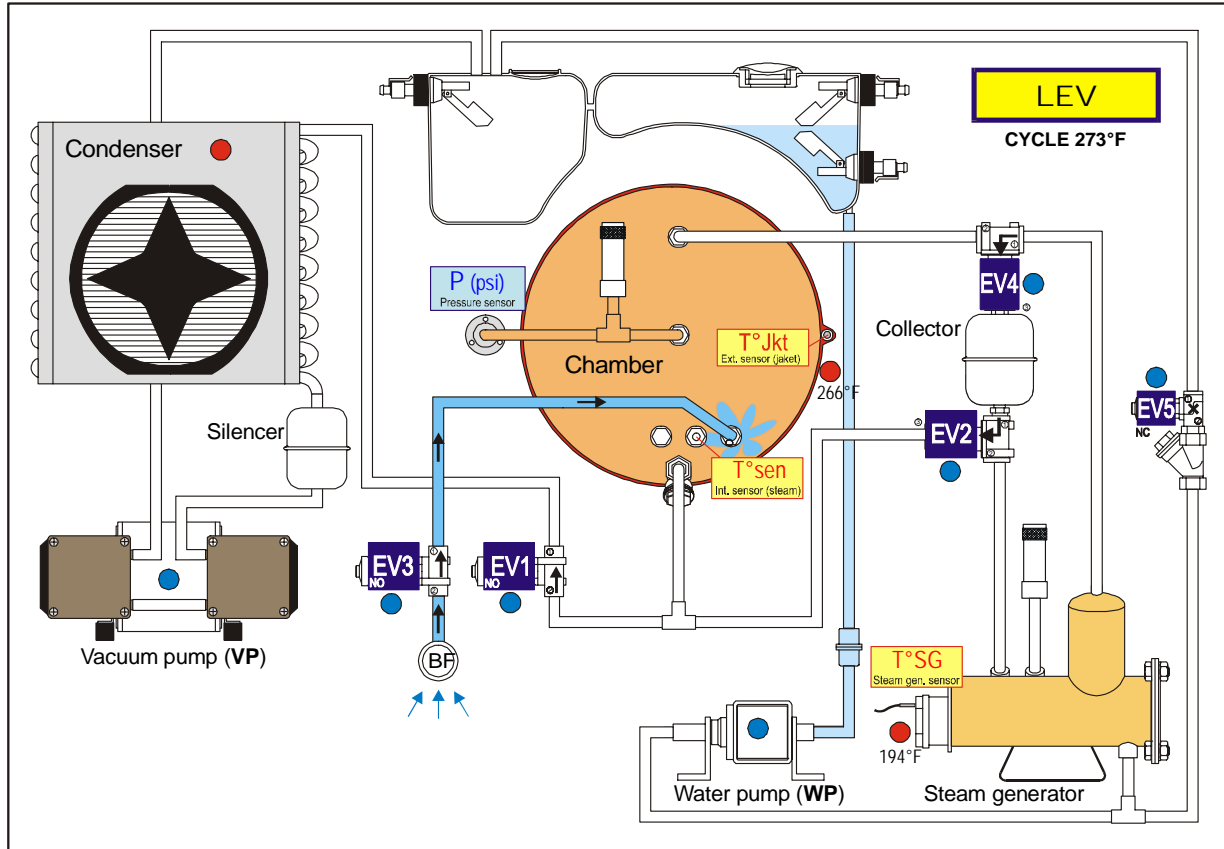

Stages	Actions	Comments
20	VEN duration = 40 sec. VP OFF	↘ End of VEN ↗ Start of LEV Levelling
21	LEV duration = 30 sec. Acoustic signal	End of the cycle

Notes :

---



---



---



---



---

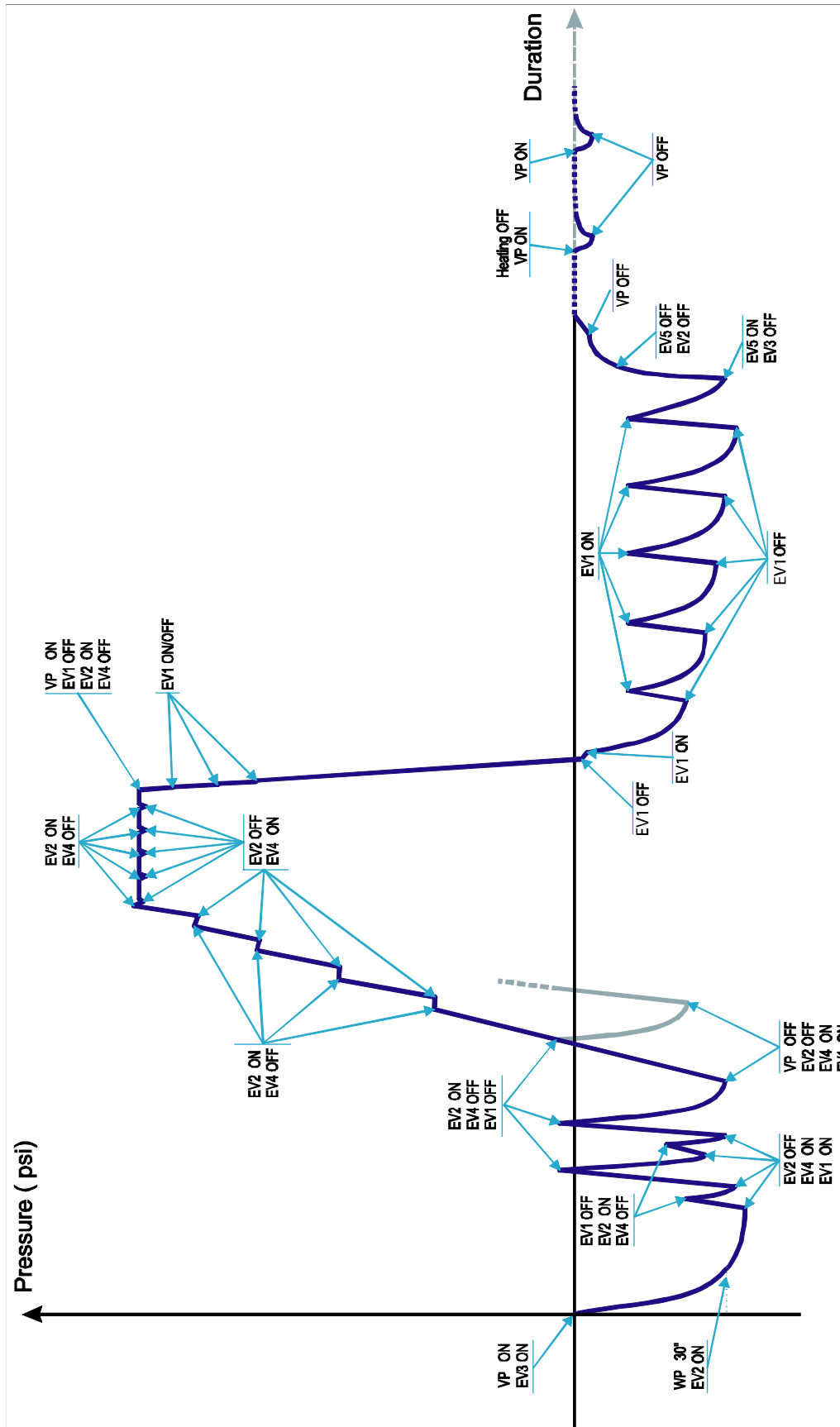

**2CS System –  
Condensation  
Collecting  
System**

This system operates during various phases of the cycle:

- ▶ At every pre-vacuum pp/pv phase change.
- ▶ During pph ( at 10.1, 17.4, 23.2 and 27.5 psi).
- ▶ During the sterilization process (every 50 seconds).

Condensed steam continuously flows from the sterilization chamber (1 below) to the condensation collector, then returns to the steam generator (2 below) at the above mentioned phases to be re-vaporized.

Check the system is operating correctly by watching the condensed steam circulate through the transparent Teflon tubing.

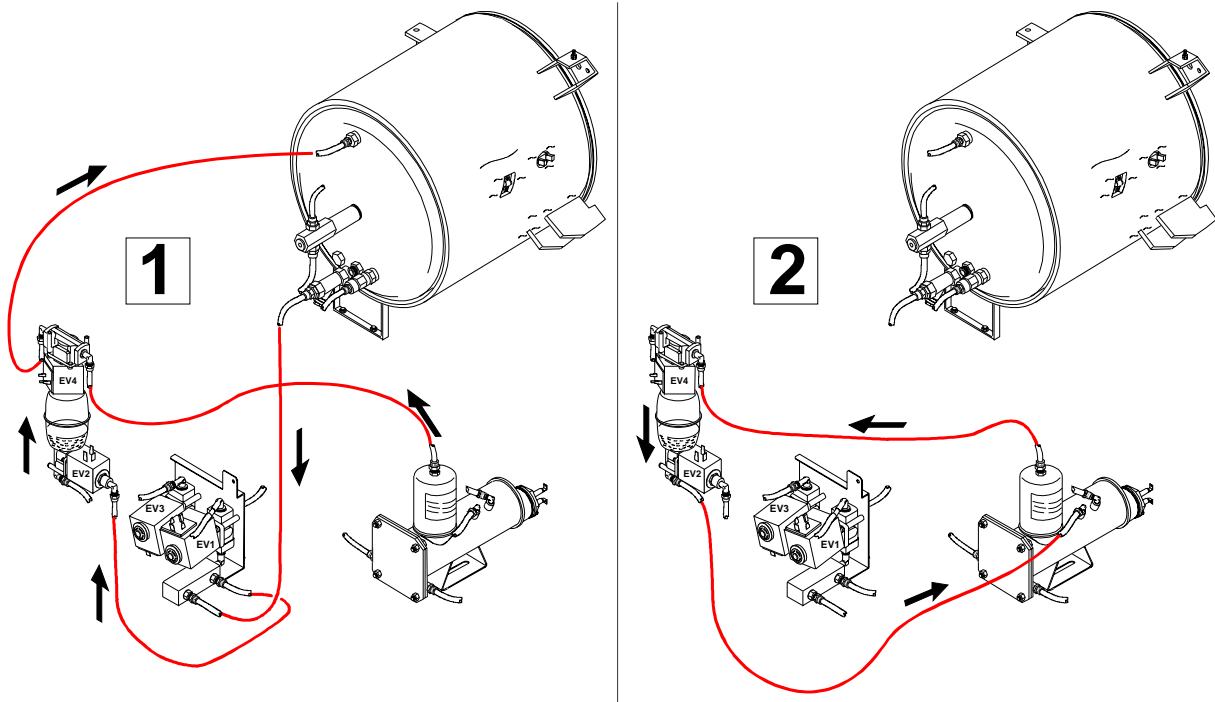

**Technical Specifications**

Power Requirements	Single phase 230 VAC +/- 10% - 50/60Hz - 10A
<b>Sterilizer:</b>	
- Working temperature/Humidity	50°- 104°F / 0-90% 10°- 40°C / 0-90%
- Storage temperature/Humidity (empty)	-4°- 140°F / 0-90% -20°- 60°C / 0-90%
- Minimum atmospheric pressure	7.25 psi (0.5 bar)
- Nominal voltage	230 V
- Maximum absorbed power	2100 W
- Maximum current	9.2 A
- Dimensions overall	W: 17.5 / H: 16.1 / D: 20.5 (in) W: 445 / H: 410 / D: 520 (mm)
- Maximum space required	W: 19.1 / H: 18.1 / D: 22.4 (in) W: 485 / H: 460 / D: 570 (mm)
- Clutter of the door movement	W: 14.2 / H: 15.8 / D: 14.2 (in) W: 360 / H: 400 / D: 360 (mm)
- Weight empty	106 lb. (49 kg)
- Max. mass in working condition fully loaded	140N/foot (129.4 N/m <sup>2</sup> )
- Maximum heat output	3000 KJ/hr
- Maximum noise level	< 53 dB
<b>Steam generator:</b>	
- Power/Voltage	1700 W/230 VAC
- Max. pressure/Max. temperature	58 psi/302°F (4.0 bar/150°C)
- Safety overpressure valve	72.5 psi (5.0 bar)
<b>Sterilization chamber:</b>	
- Power/Voltage	1000 W/230 VAC
- Maximum pressure/Max. temperature	34.8 psi/280°F (2.4 bar/138°C)
- Safety overpressure valve	36.3 psi (2.5 bar)
- Total volume	17 liters (18 qt.) Dia.: 9.8 in (250 mm)/Depth: 13.8 in (350 mm)
- Usable space (identical for all cycles)	12.7 quarts W: 7.67/H: 8.07/D: 11.81 (in) 12 liters W: 195/H: 205/D: 300 (mm)
- Filter	0.3 µm
<b>Distilled water (or demineralized):</b>	
- Water quality	Conform to the 13060-1 annex E
- Min./Max. consumption (full porous load)	7 to 12 oz (0.2 to 0.35 liter)
- Double tank/Autonomy	Min 8 cycles (full porous load)
Connections	Parallel printer port
Miscellaneous	Fully micro-processor driven and controlled touchscreen Mains filter/2KV over tension filter Programmable stand-by mode

**Technical Specifications**  
(continued)

STERILIZER CLASS B conforms with the following directives and norms :		
93/42/EEC	Medical devices	
PrEN 13060-1	(11/97)	Small steam sterilizer - General requirements. Type and work tests.
PrEN 13060-2	(11/97)	Small steam sterilizer - Particular requirements for B type.
EN 61010-1	(09/94)	Laboratory equipment - Safety requirements.
EN 61010-2-041	(08/97)	Laboratory equipment - Specific instructions for steam sterilizer.
EN 50081-2	(06/97)	Electromagnetic compatibility - Emission.
EN 50082-2	(06/97)	Electromagnetic compatibility - Immunity.
Chamber		Development and testing conform to pressure vessel regulations.
Steam generator		Development and testing conform to steam generator regulations.



## Section 2 – Maintenance

### User Maintenance

Note: Remove the mains cable before examining the sterilizer.

### Maintenance Program

Frequency	# of Cycles	Operation	Spare Number
Weekly	50	Clean the door seal.	-
		Clean the chamber, trays and rack.	-
		Clean the external surfaces.	-
Every 3 months	400	Replace the filter.	54.0067.00
Weekly	50	Clean the main water tank.	-
Every year	1000	Replace the door seal.	54.0014.00
* Every 3 years	4000	Service by an approved technician.	-

\* Refer to medical device regulations for your country.

The maintenance submenu indicates the remaining number of cycles before general servicing, replacement of the filter and cleaning of the door seal are required.

The counters decrease in value after each cycle. When a counter reaches zero, a corresponding message appears at the bottom of the selection screen. Read the message and press **OK**. The counter is automatically reset. The **Select a Cycle** screen appears.

Reset the counter manually for service that has been completed before the counter reaches zero. Place the cursor in front of the operation with the **UP** and **DOWN** icons and reset it by pressing **OK**.

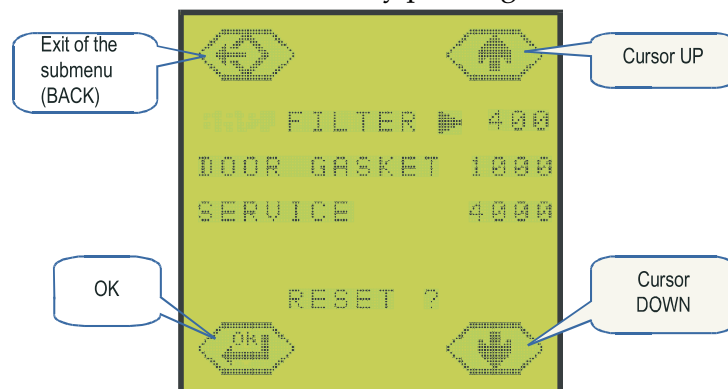

**Cleaning the Door Seal**

Clean the door seal and the porthole with a lint free cloth saturated with alcohol.

The porthole can also be cleaned with a non-abrasive detergent.

**Cleaning the Chamber, Trays and Tray Holder**

1. Remove the trays from the chamber.
2. Disconnect and remove the rack.
3. Clean the chamber with a damp sponge moistened with a detergent or scouring agent if necessary.
4. Rinse with a damp sponge to remove all traces of the cleaning agent.

Clean the rack and trays using the same procedure.

Note:

- ▶ Ensure that you clean all around the sterilizer chamber.
- ▶ Do not bend or damage the temperature sensor at the bottom of the chamber.
- ▶ Never use disinfectants to clean the chamber.

**Cleaning External Components**

Clean the external parts with a damp cloth and mild detergent.

Note:

- ▶ Never use scouring agents or highly abrasive products.
- ▶ Do not use excessive amounts of water to wash the sterilizer; this may damage the electrical components and safety mechanisms.
- ▶ Take care not to scratch the plastic film in front of the touchscreen.

**Replacing the Filter**

1. Open the service door.
2. Unscrew the filter by hand (counter-clockwise).
3. Insert and manually screw the new filter into position.

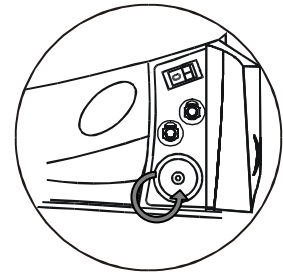

# Lisa Sterilizer Service Guide Maintenance

---

## Cleaning the Main Water Tank

Completely drain both water tanks (main and used water tank).

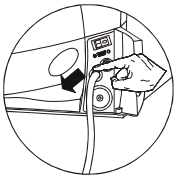
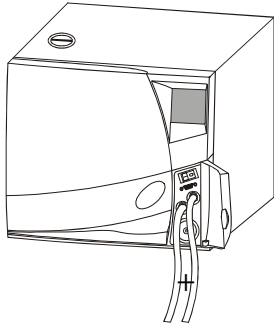

1. Open the service door.
2. Insert the drain tube into the quick disconnect coupling drain cock of the used water tank (right). Allow the entire contents of the tank to empty and discard the used water.
3. Disconnect the drainage hose by pressing the push-button on the drain cock.
4. Insert the drain tube into the quick disconnect coupling drain cock of the main water tank (left). Allow the entire contents of the tank to empty. Discard the water.
5. Disconnect the drainage hose by pressing the push-button on the drain cock.

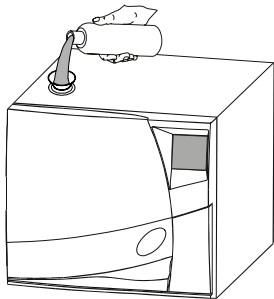

6. Fill the main reservoir with 3 quarts (2.8 liters) of distilled or de-mineralized water and  $\frac{3}{4}$  cups (0.2 liters) of 90% alcohol.

Note:

- Do **not** run a cycle at this point.
7. Allow the solution to sit for 30 minutes.
  8. Drain the main tank and discard the 3.17 quarts (3 liters) of solution.
  9. Fill the main tank with 3.17 quarts (3 liters) of distilled or de-mineralized water.
  10. Run an empty cycle.

**Replacing the Door Seal**

1. Fully open the door of the sterilizer.
2. Remove the door seal by hand.
3. Carefully clean the seal seat with a cotton bud moistened with alcohol.
4. Moisten the new door seal with soapy water. **Do not lubricate.**
5. Insert the seal in the sequence illustrated in the following diagrams.

Up

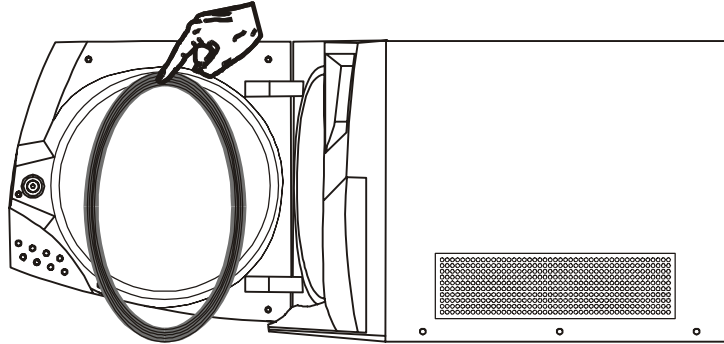

Down

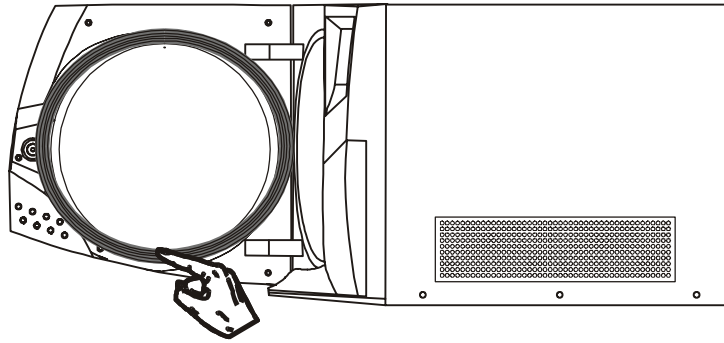

Left & Right

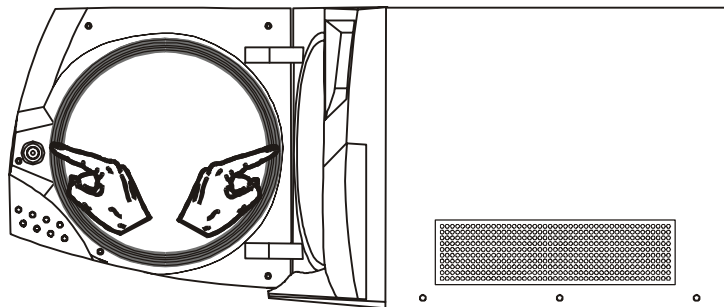

# Lisa Sterilizer Service Guide Maintenance

---

## Service Checklist

Proper maintenance assures the Lisa continues to operate effectively.

A-dec recommends service by an approved technician every 3 years or 4000 cycles. (Use service kit 54.0152.00.)

- ✓ Replace 5 Electro-valves.
  - EV2/EV4/2CS Collector subset
  - EV1/EV3 subset
  - EV5 Electro valve
- ✓ Replace vacuum pump membrane kit.
  - Vacuum pump membrane kit
- ✓ Replace water filter.
- ✓ Replace the steam generator heating element.
  - Steam generator heating element
  - Viton steam O-ring
- ✓ Clean the sterilization chamber.
- ✓ Clean the sterilization chamber filter.
- ✓ Clean the steam generator filter (EV5).
- ✓ Clean the condenser.
- ✓ Check the pneumatic connections.
- ✓ Check the electrical connections.
- ✓ Check the door locking system.
- ✓ Check the two pressure safety valves.
- ✓ Check the safety devices.
- ✓ Check the sterilizer according to Section 8 of this manual.



**Section 3 – Exploded Views & Circuit Diagrams**

**Exploded Views**

**Accessories**

<b>Ref.</b>	<b>Part Number</b>	<b>Description</b>
1	54.0019.00 (MB17) 54.0426.00 (MB22)	Anodized perforated aluminum tray
2	54.0018.00 (MB17) 54.0425.00 (MB22)	Reversible rack
3	54.0029.00	Drain tubing
4	54.0046.00	Mains cable, 67 in. (170 cm)
5	54.0024.00	Funnel
6	54.0017.00	Tray holder
7	54.0188.00	Owner's Guide

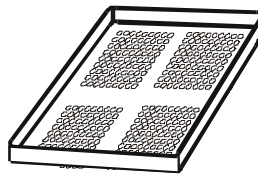

1

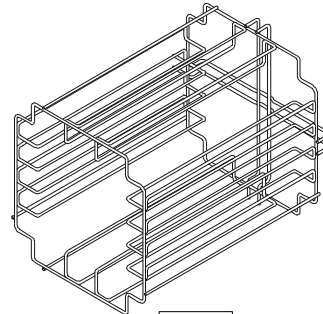

2

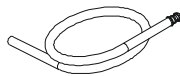

3

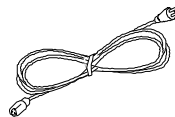

4



5



6



7

**External Parts  
(1 of 2)**

Ref.	Part Number	Description
1	54.0127.00	Water tank cap
2	54.0123.00	Water tank / cover grommet
3	54.0138.00	Used water tank seal cap
4	54.0118.00	Used water tank silencer
5	54.0251.00 (MB17) 54.0424.00 (MB22)	Housing / cover
6	54.0037.00	Composite washer
7	54.0036.00	Screws : Pan Head Phillips M5 x 6 mm
8	54.0358.00	Rear housing plate
9	54.0359.00	Chassis foot
10	54.0360.00	Black plug

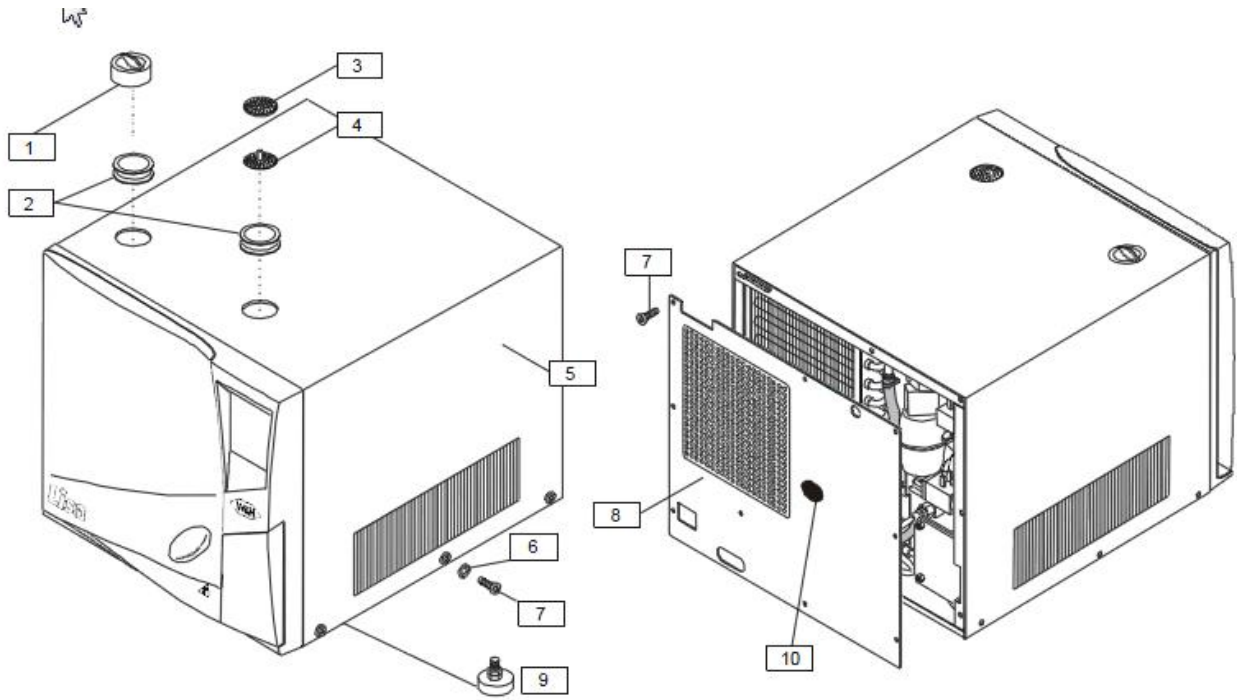



## External Parts (2 of 2)

Ref.	Part Number	Description
1	54.0023.00	Composite door cover
2	54.0014.00	Door seal
3	54.0022.00	Composite fascia
4	54.0021.00	Composite technical door
5		Technical door sticker
6	54.0132.00	Service door pin
7	54.0253.00	Touchscreen complete
8	54.0025.00	Touchscreen external protection
9	54.0121.00	EMC finger (carter)
10	54.0361.00	Screw
11	54.0026.00	Composite fascia-Cover seal
12	54.0362.00	Retaining screw
13	54.0363.00	Retaining washer

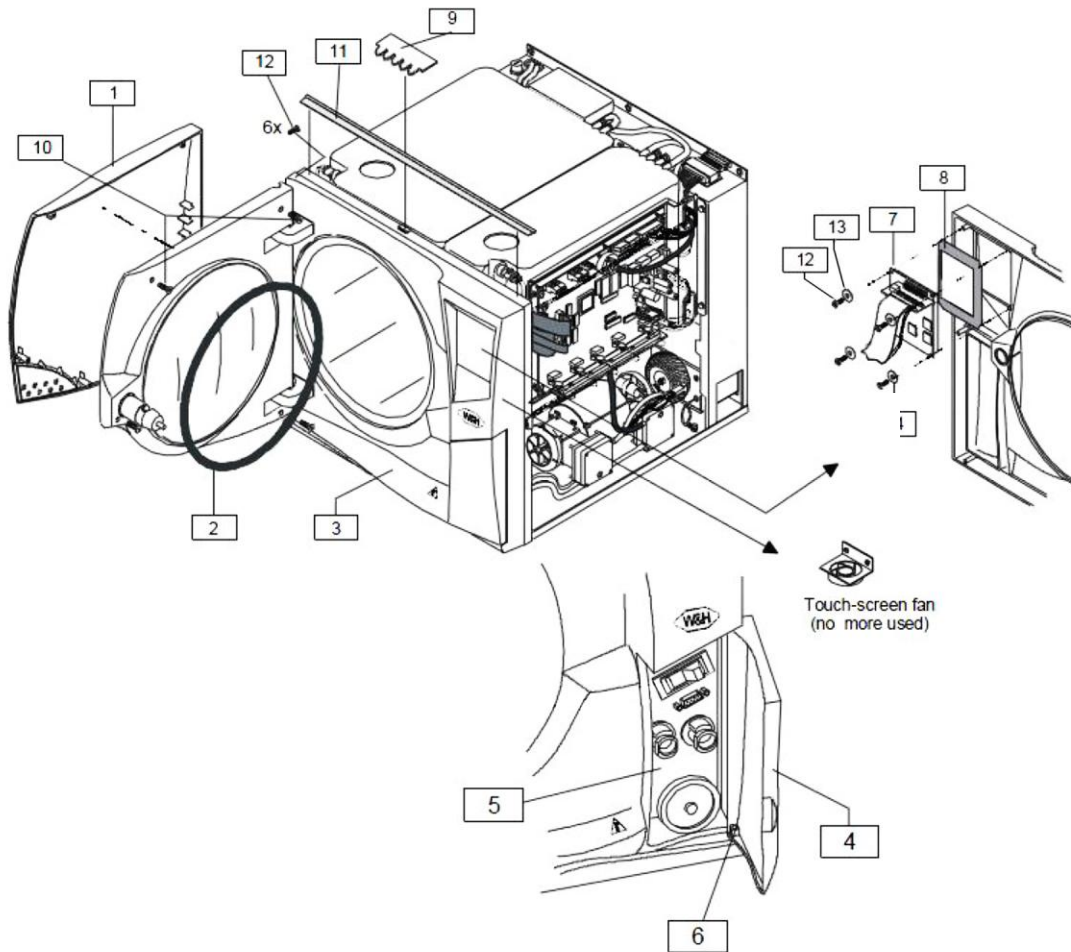

**Door Complete**

<b>Ref.</b>	<b>Part Number</b>	<b>Description</b>
1	54.0130.00	Door complete subset
2	54.0033.00	Lock clip
3		Door locking arm
4	54.0365.00	Screw, button head hex socket M5 x 10 mm
5		Washer 5.3 ID x 20 mm OD
6		Door arms actuator
7	54.0260.00	Door locking pin
8		Teflon guide
9		Spacer washer, 20 mm ID x 28 mm OD x 0.5 mm thk
10	54.0034.00	Lock clip
11	54.0039.00	Door locking pin seal
12	54.0365.00	Screw : Hex socket cap m3 x 10 mm
13	54.0006.00	Door locking arm spring
14		Nut M5
15	54.0366.00	Screw, button head hex socket m5 x 20 mm
16		Wing washer D5
17	54.0134.00	Screw M4 x 5mm
18	54.0140.00	Spacer washer
19		Screw, hex socket cap M8 x 50 mm
20		Door hinge mount (door side)
21		Washer, 5.3 mm ID x 15 mm OD
22	54.0005.00	Porthole spring
23		Teflon guide D16
24		Lock clip D16
25		Cast aluminum door
26	54.0414.00 †	Fixed eccentric porthole disc
27	54.0368.00	Screw, button head hex socket M4 x 6 mm
28	54.0009.00	Friction disc 1mm
29	54.0369.00	Rotating door locking disc
30	54.0010.00	Spacer disc 0.5mm
31	54.0370.00	Porthole

† Indicates that the individual part is not for sale

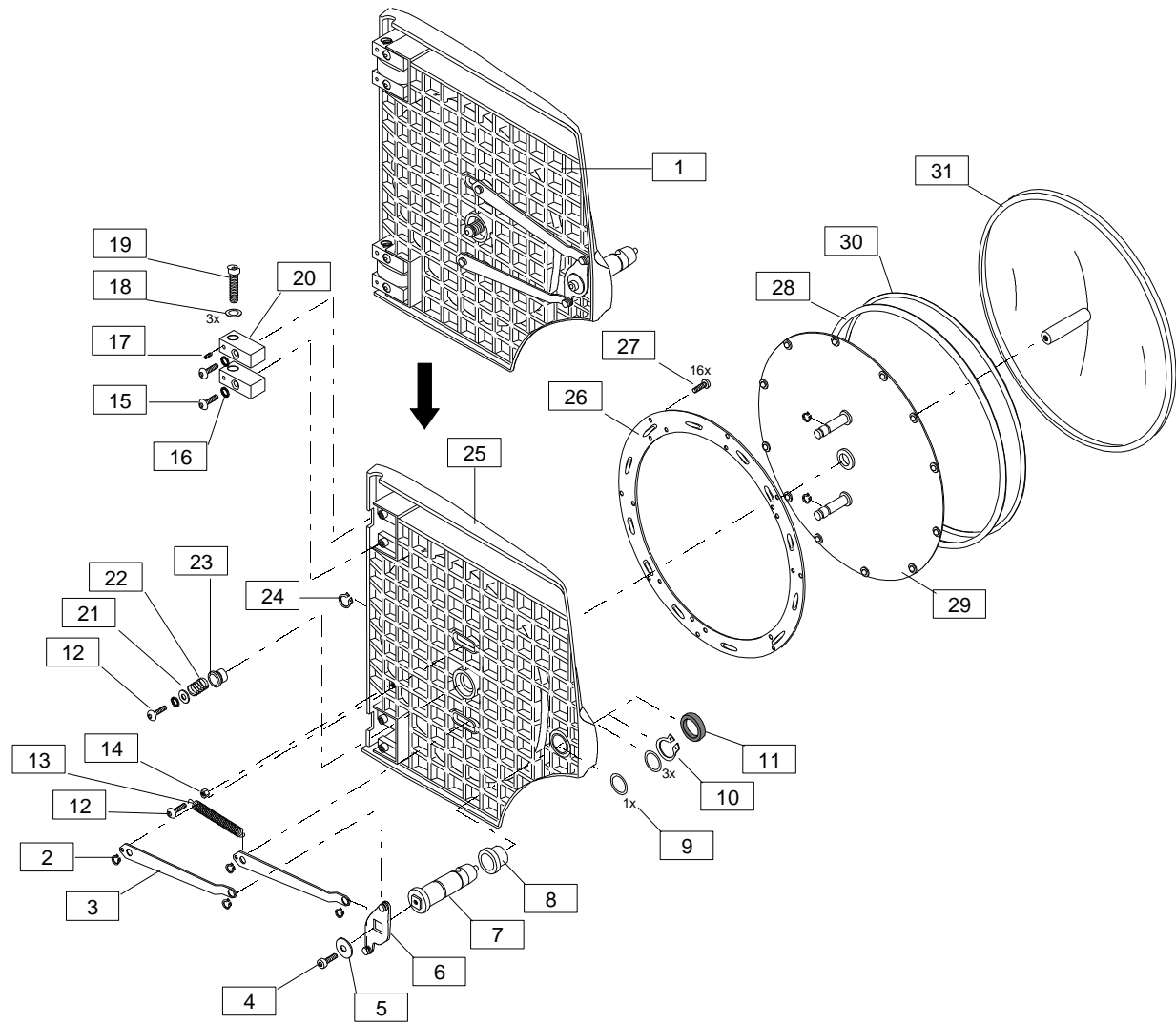

**Water Tank /  
Facade**

Ref.	Part Number	Description
1		Water tank complete
2	54.0020.00 (MB17) 54.0430.00 (MB22)	Water tank only
3	54.0047.00	Water level sensor
4	54.0145.00	Water level sensor seal
5	54.0142.00	Pipe seal cap
6		Door hinge (chamber side)
7	54.0008.00	Door hinge 0.5mm spacer
8		M10 flat washer
9		M10 split lock washer
10		Screw, hex socket cap screw M10 x 20 mm
11		Screw, hex socket cap screw M6 x 16mm
12		M6 split lock washer
13		6 mm ID flat washer
14		Base frame
15	54.0139.00	Main switch (circuit breaker)
16		EMC filter 9 pin
17	54.0064.00	Drain fitting, female (NM blue)
18	54.0063.00	Drain fitting, female (NM grey)
19	54.0067.00	Filter
20	54.0379.00	Screw M3.5 x 9.5 mm
21	54.0377.00	Nut M5

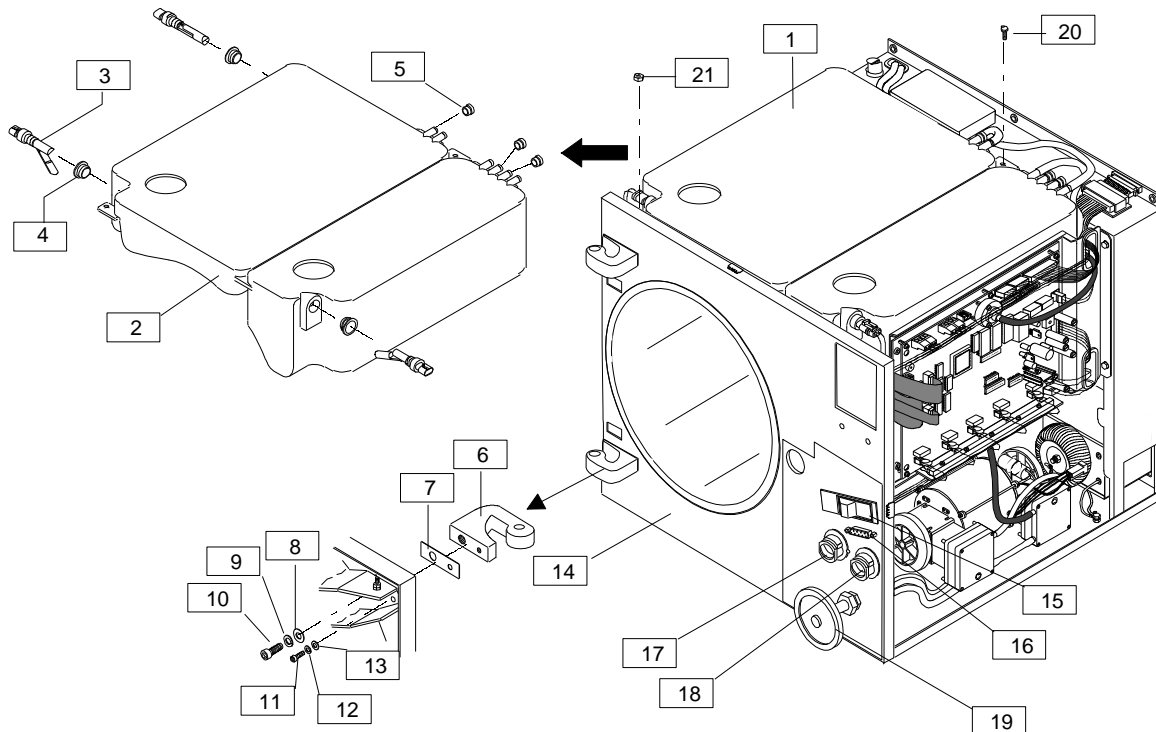

1	54.0150.00	Vacuum pump silencer
2	54.0031.00	CPU board
3		CPU board metal carrier
4	54.0050.00	Vacuum pump
5		Internal lock washer, 5 mm
6	54.0365.00	Screw, button head hex socket M5 x 10 mm
7	54.0372.00	Screw, button head hex socket M4 x 6 mm
8	54.0053.00	Vacuum pump head (2 pce)
9	54.0051.00	Vacuum pump membrane kit (4x valve + O-ring + 2x diaphragm)
10	54.0052.00	Vacuum pump diaphragm (1 pce)
11	54.0373.00	Black clamp vacuum pump
12	54.0390.00	Vacuum pump connector rod with bearing
13	54.0249.00	Clip
14	54.0411.00	Vacuum pump covers
15	54.0420.00	Vacuum pump capacitor

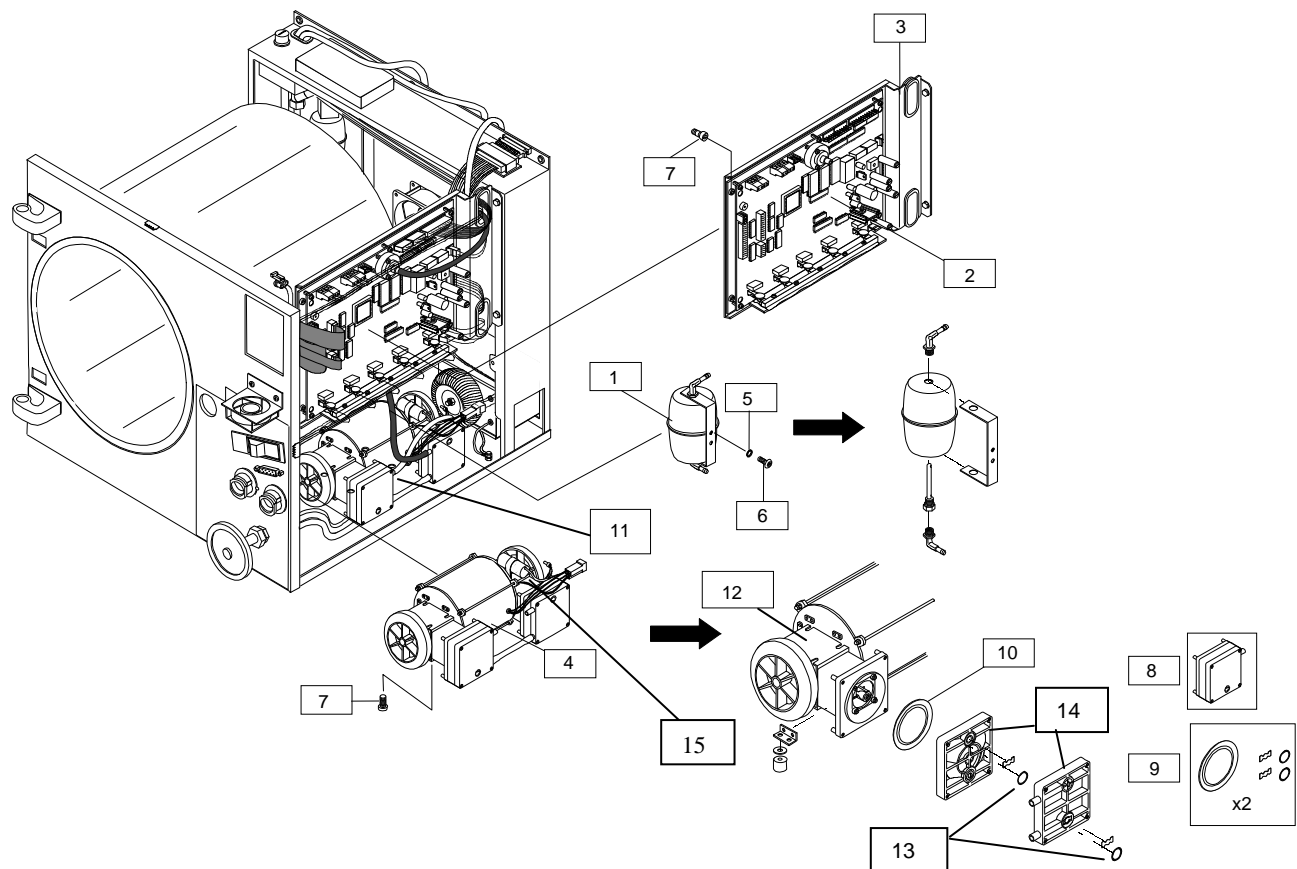

**Left Side**

Ref.	Part Number	Description
1		Steam generator complete
2	54.0071.00	Steam generator only
3	54.0092.00	Viton O-ring
4	54.0070.00	Heating element
5	54.0007.00	Fixing clip
6	54.0011.00	Thermal overload
7	54.0054.00	PT100 D 6x120
8		Water pump subset
9	54.0137.00	Water pump rubber support
10		Fitting
11	54.0038.00	Spacer 8 mm x 3.2 mm x 1.5 mm
12	54.0149.00	One-way valve complete
13	54.0049.00	Water pump
14	54.0056.00	PT100 6x40 Class B outside chamber
15	54.0012.00	Chamber thermal-overload
16	54.0066.01	Water filter
17	54.0374.00	Nut
18	54.0375.00	Washer
19	54.0376.00	Grower washer
20	54.0377.00	Nut
21		Grower washer
22		Grower washer
23	54.0368.00	Screw
24	54.0318.00	Gasket

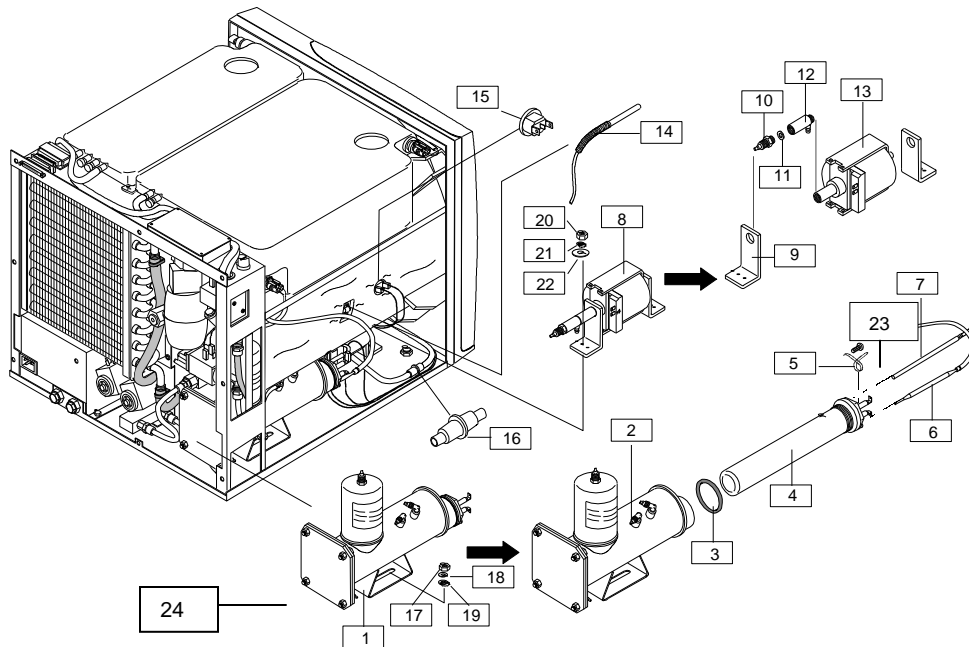

## Rear Side (1 of 2)

Ref.	Part Number	Description
1		Condenser subset
2	54.0126.00	Condenser
3	54.0045.00	Condenser fan 230Vac
4	54.0128.00	Mains filter box complete with transformer
6	54.0380.00	Washer
7	54.0371.00	Screw
8	54.0015.00	Nylon nipple
9	54.0382.00	E-clamp

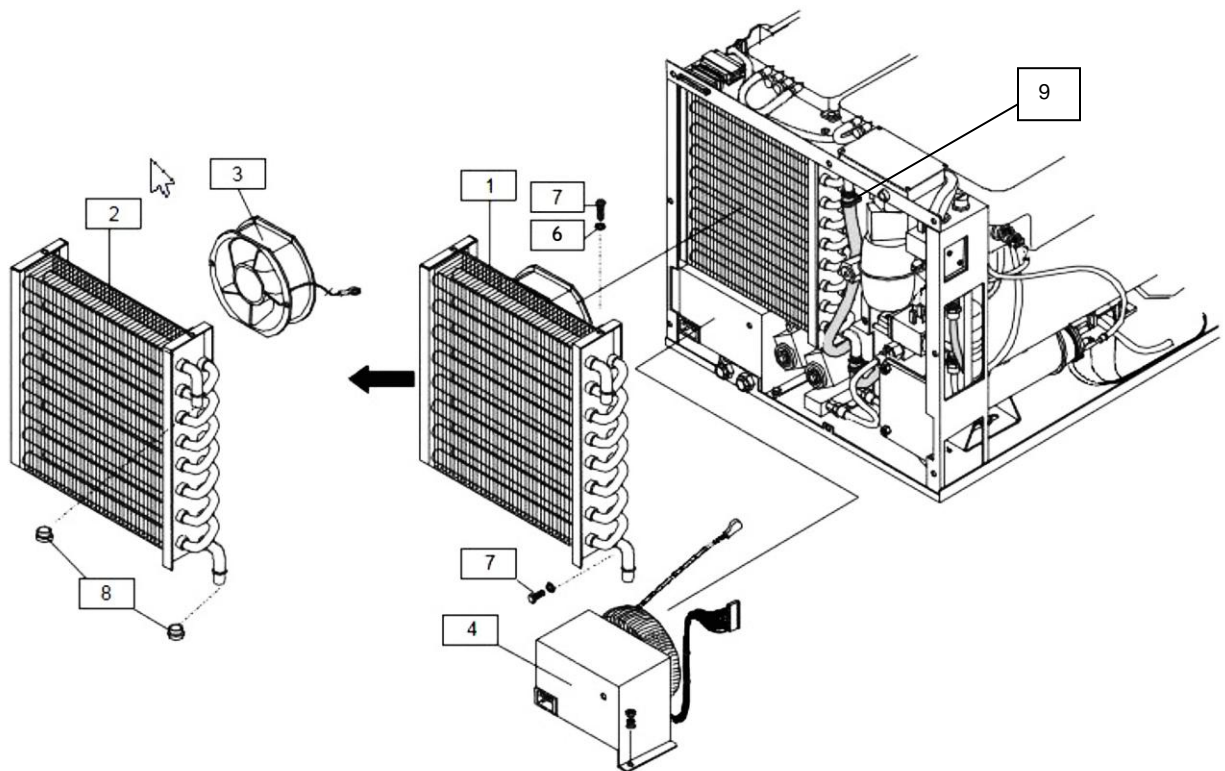

**Rear Side  
(2 of 2)**

Ref.	Part Number	Description
1	54.0027.00	EV2 / EV4 / 2CS subset
2	54.0028.00	EV1 / EV3 subset
3	54.0090.00	EV5 / Filter subset
4	54.0066.01	Water filter
5	54.0055.00	PT100 5x100 Class A internal
6	54.0141.00	Chamber outlet filter
7	54.0410.00	Bi-cone Teflon seal
8	54.0382.00	Black clamp
9	54.0383.00	Screw
10	54.0384.00	Black Cover
11	54.0381.00	Plug

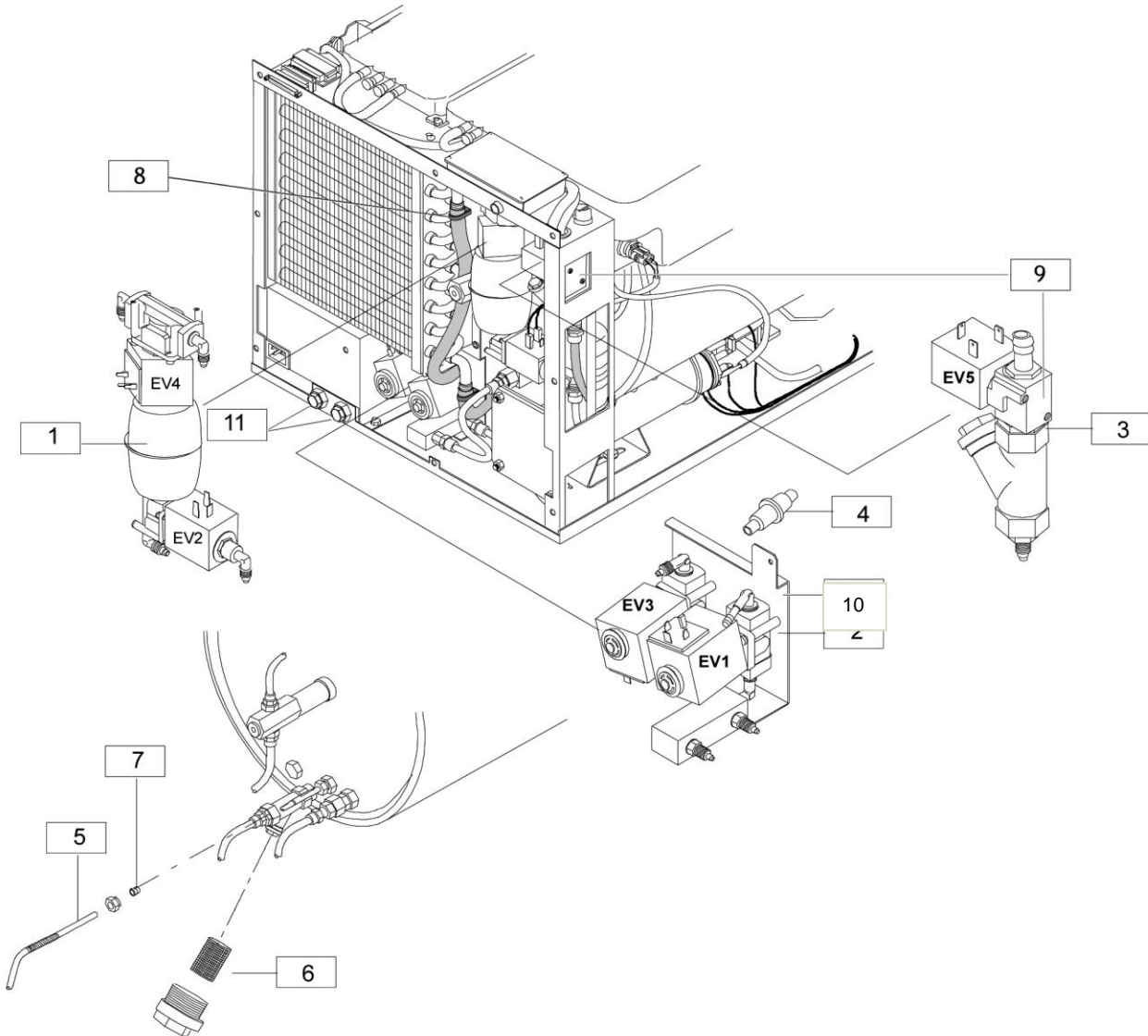



## Top Side

Ref.	Part Number	Description
1		EMC filter 9-pin
2		Printer flat cable EMC ferrite
3	54.0129.00	Pressure safety valves subset
4		Safety valve manifold
5	54.0385.00	Screw
6	54.0380.00	Washer
7	54.0062.00	Pressure safety valve 5 bar
8	54.0061.00	Pressure safety valve 2.4 bar
9		Safety valves housing
10	54.0011.00	Steam generator thermal-overload

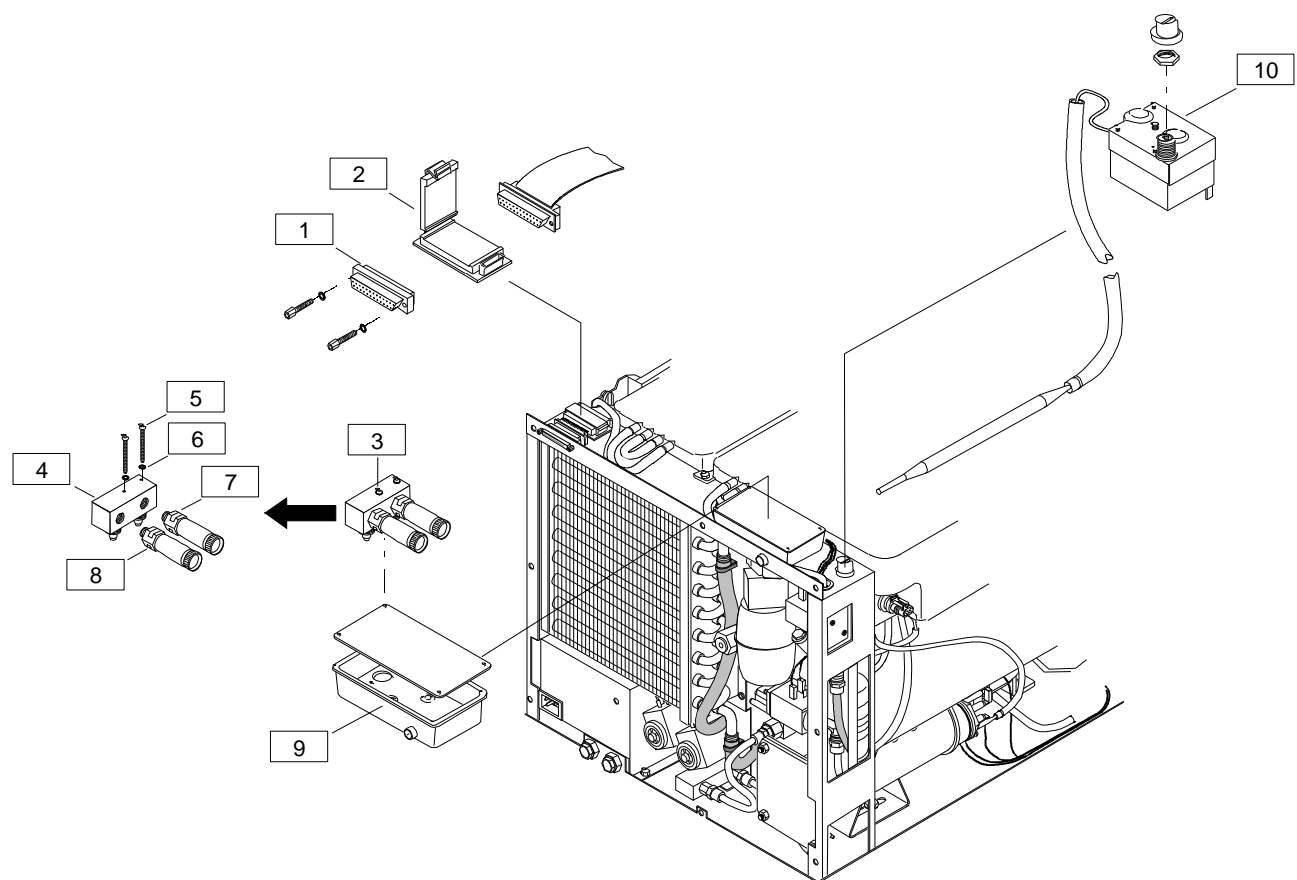

**Door Locking System**

Ref.	Part Number	Description
1	54.0391.00	Door locking system complete
2		Washer
3		Screw
4	54.0133.00	Door locking Teflon friction washer
5	54.0035.00	Door closed holding finger
6		Door locking mechanism mounting block
7	54.0125.00	Door switch actuating axle
8	54.0004.00	Door closing contact axle spring
9	54.0030.00	Door locking 24VDC motor + speed reducer
10	54.0136.00	Door switch actuator (screw)
11		Door switch actuating cam support
12		Cam support locking screw
13	54.0124.00	Nylon door switch actuator
14	54.0147.00	Door locking switch board with bracket
15	54.0388.00	Door locking system clip
16	54.0387.00	Door locking system spacer

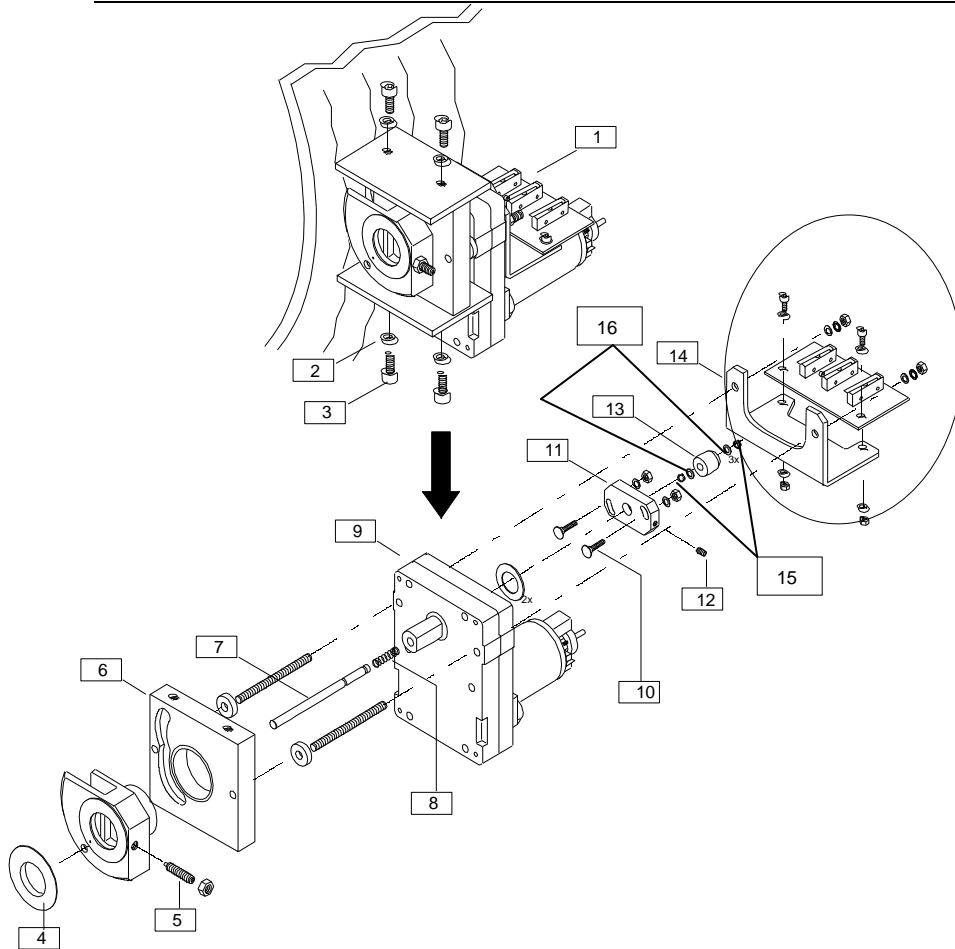

**EV2/EV4/2CS  
Collector Subset  
(54.0027.00)**

Ref.	Part Number	Description
1		2CS collector 15cc
2		3 way valve 1/4x2.3 24VCC (EV2-EV4)
3		3 way valve coil
4		Fitting 1/4 - 1/8
5		Fitting 90° M1/4 T6/4
6		Fitting 90° F1/8 T 6/4

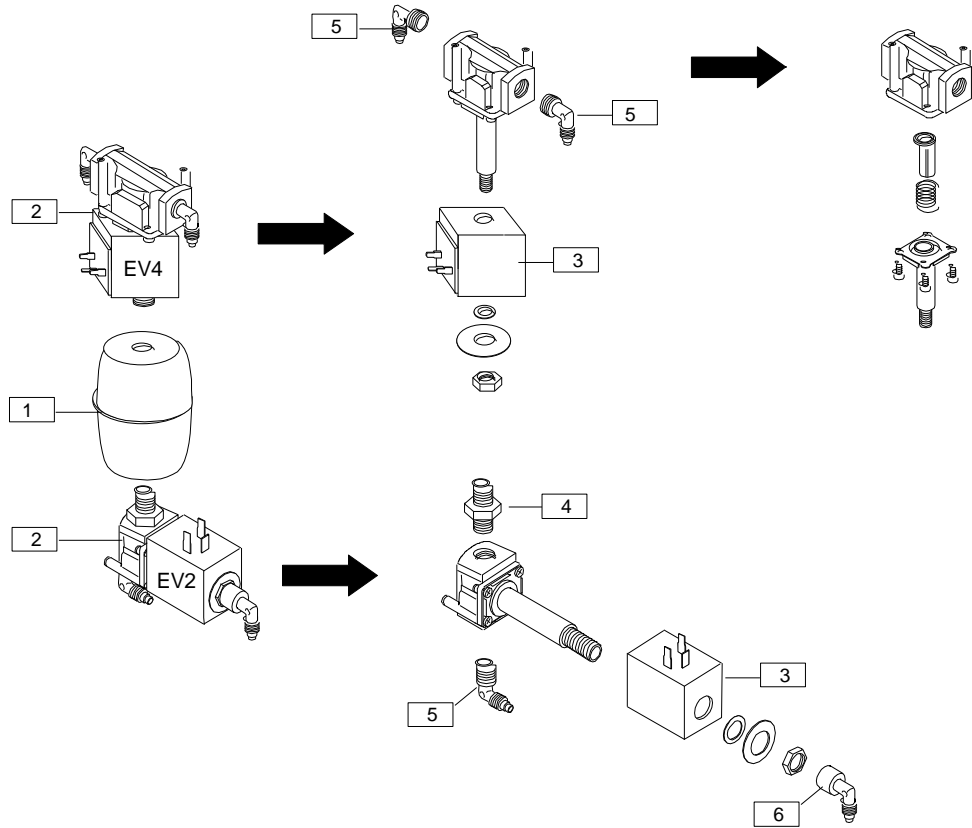

**EV1/EV3 Subset  
(54.0028.00)**

Ref.	Part Number	Description
1		EV1-EV3 metal bracket
2	54.0048.00	2 way valve NO 1/4x4.5 24VCC (EV1-EV3)
3		2 way valve coil
4		Fitting 90° M1/4 D7
5		Fitting 90° M1/4 T6/4
6		Fitting M1/4 T6/4
7		(EV1) 3-way manifold
8	54.0153.00	Nylon clip
9		Fitting M1/4 T6/4

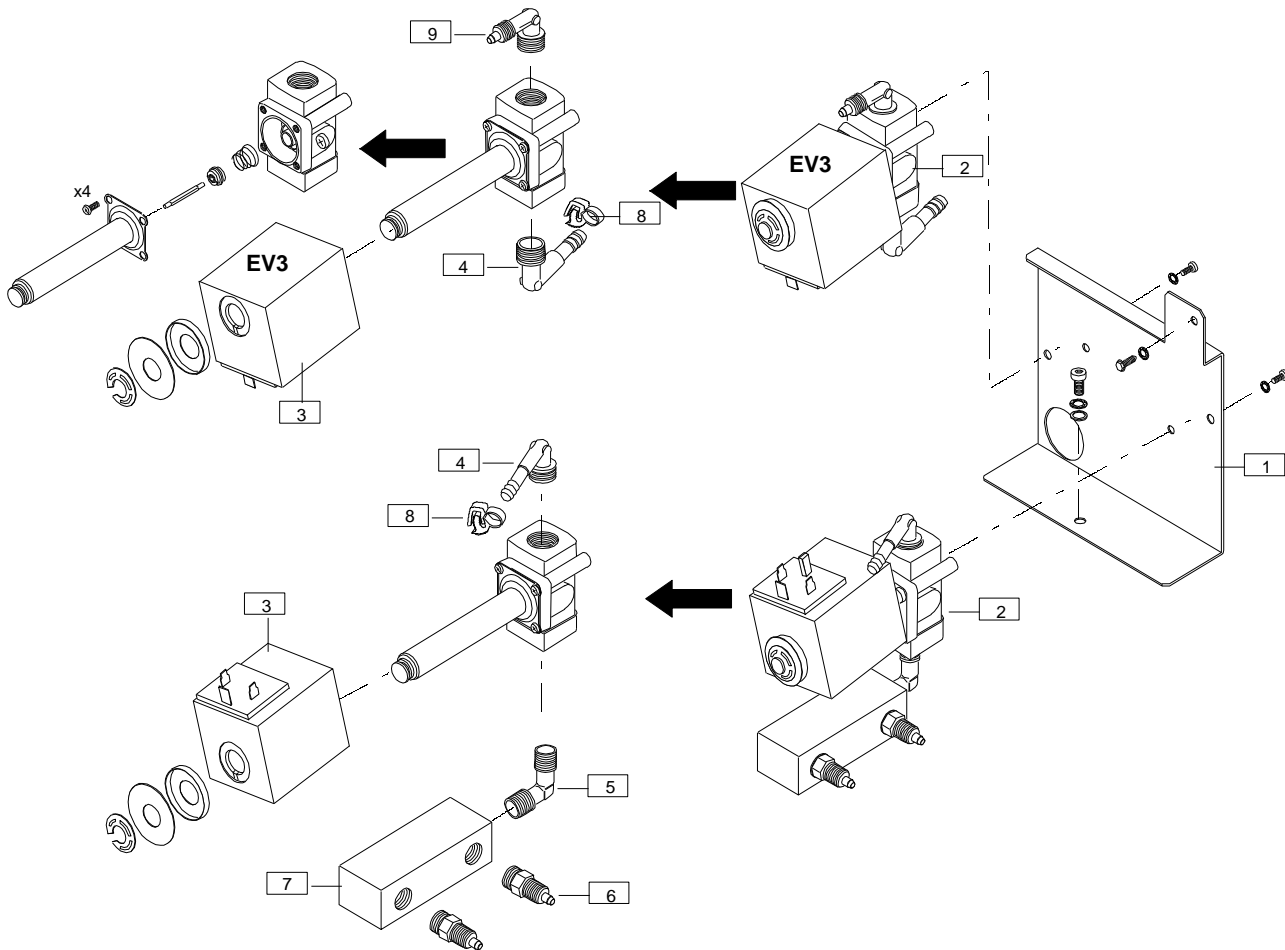

**EV5/Filter  
Subset  
(54.0090.00)**

Ref.	Part Number	Description
1		Brass filter complete (EV5 / chamber)
2	54.0323.00 †	2 way valve NC 1/8x2 24VCC (EV5)
3	54.0141.00	Filter only (EV5 / chamber)
4		Fitting M1/8 T6/4
5		Fitting M1/8 M1/4
6	54.0389.00	Fitting M1/8 D7

† Indicates that the individual part is not for sale

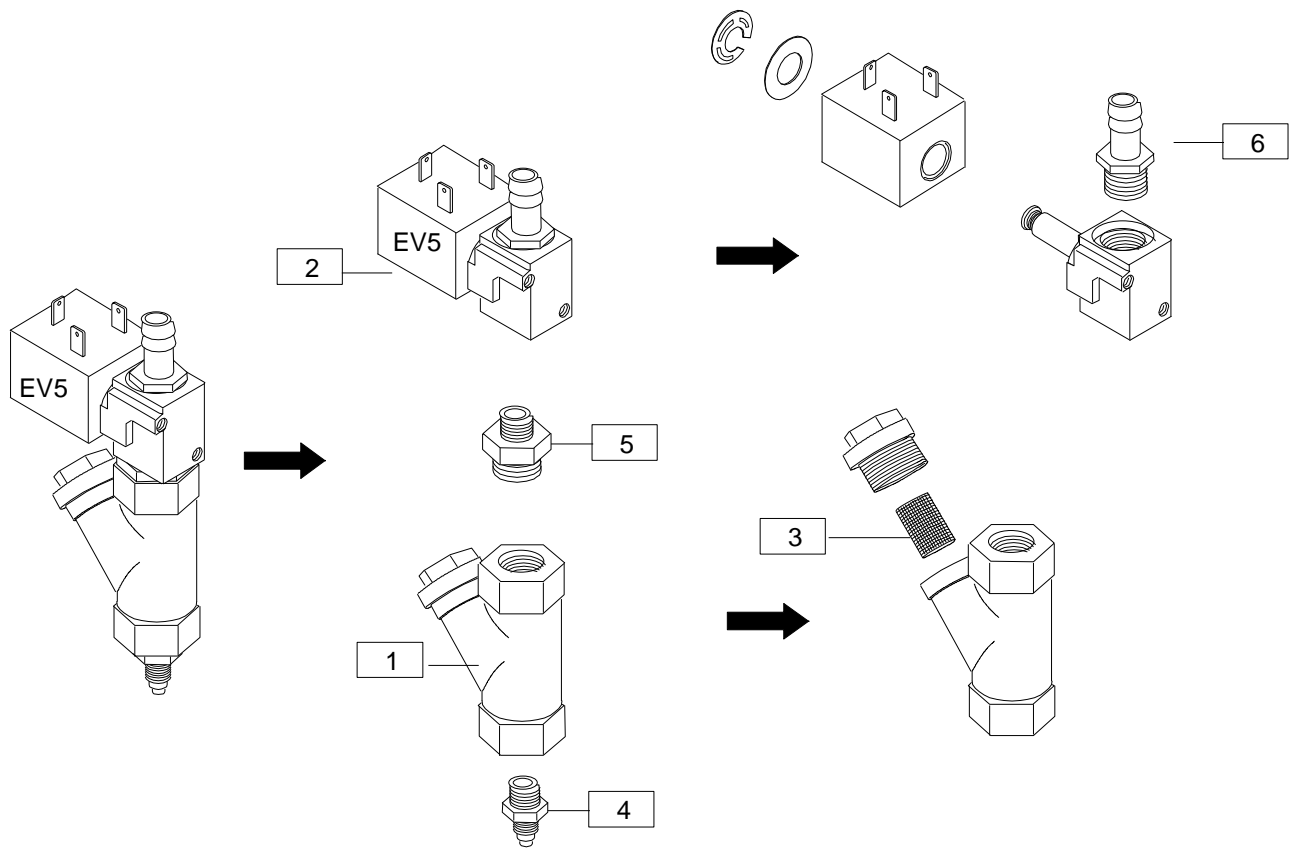

**CPU Board  
Fuses**

Ref.	Part Number	Description
1	54.0040.00	F1 (230V) : fuse Ø5x20 3.15AT 250V – Mains 230V
2	54.0042.00	F2 (9V) : fuse Ø5x20 2AT 250V – PT100 – MPX-Analog (+)
3	54.0042.00	F3 (11V) : fuse Ø5x20 2AT 250V – 5V-Digital
4	54.0041.00	F4 (-15V): fuse Ø5x20 1AT 250V – Touchscreen-analog (-)
5	54.0043.00	F5 (24V): fuse Ø5x20 6.3AT 250V – Electro-valves – Door motor

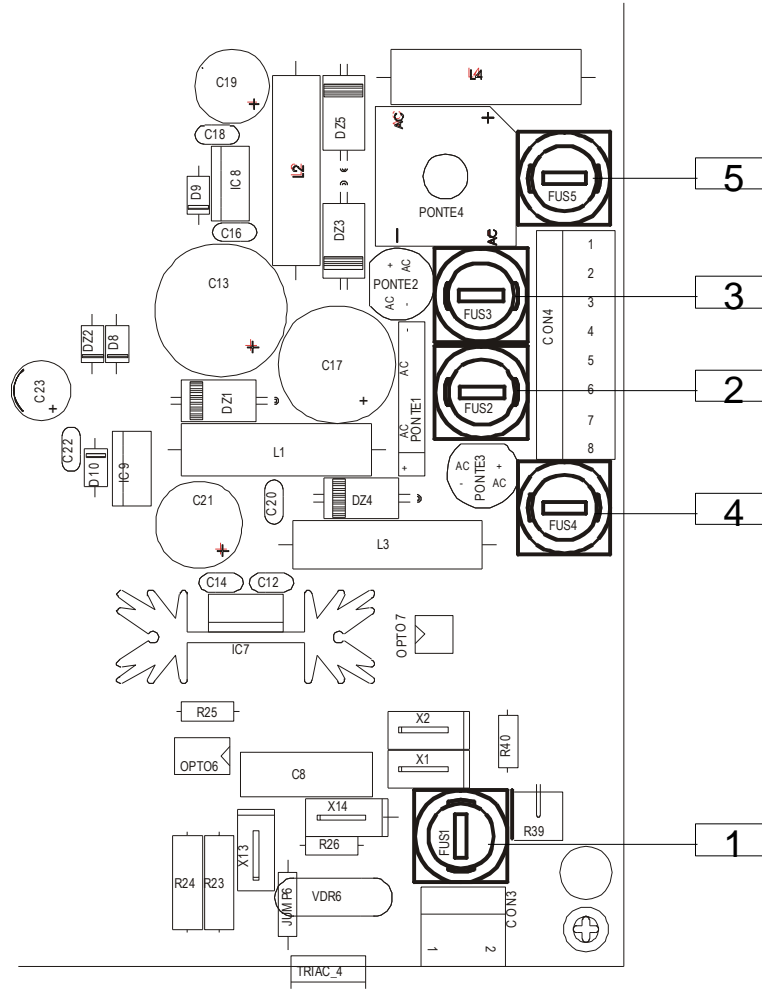

Diagrams

Electrical Circuit Diagram

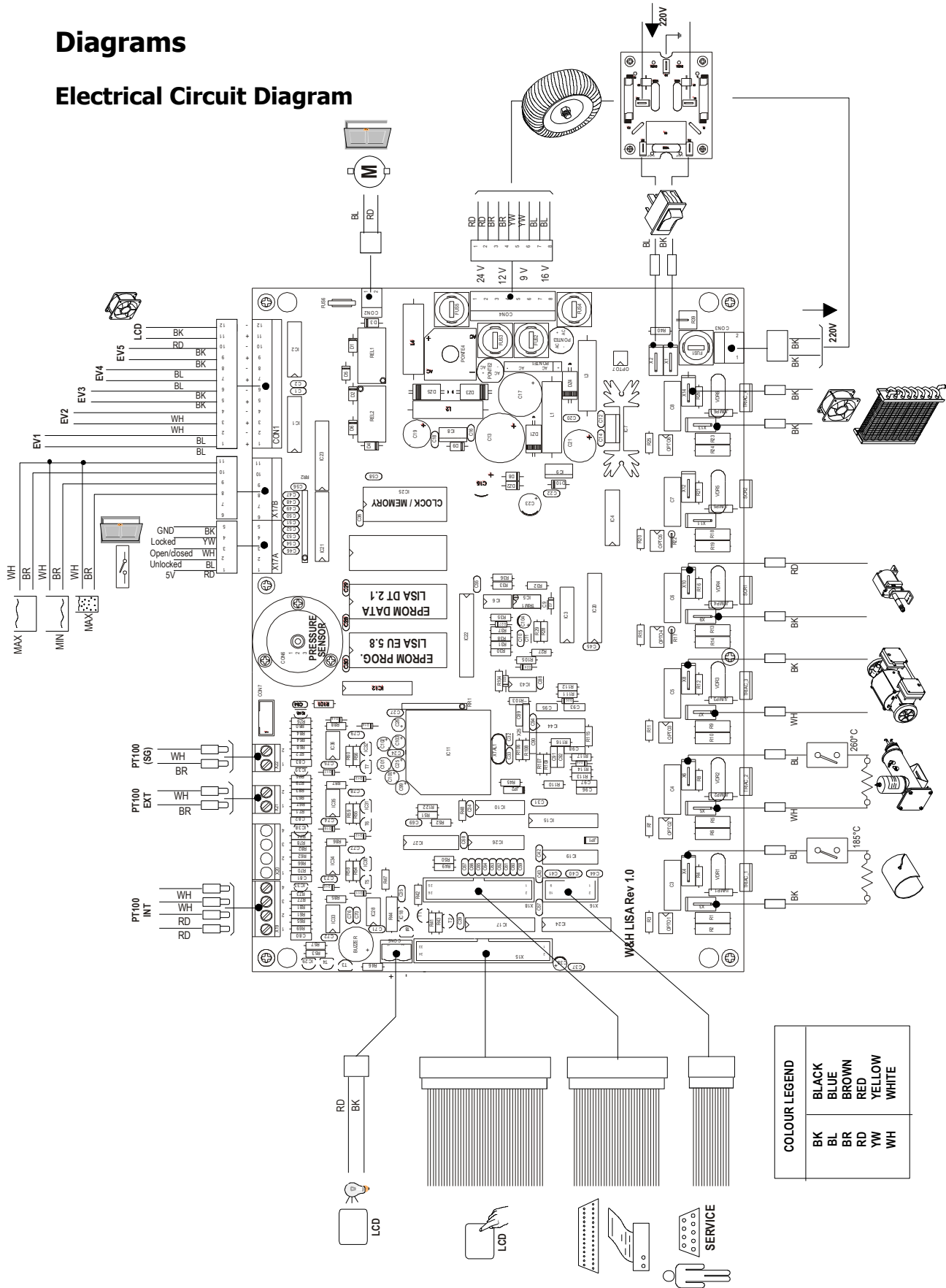

COLOUR LEGEND	
BK	BLACK
BL	BLUE
BR	BROWN
RD	RED
YW	YELLOW
WH	WHITE

Hydraulic Circuit Diagram (1 of 2)

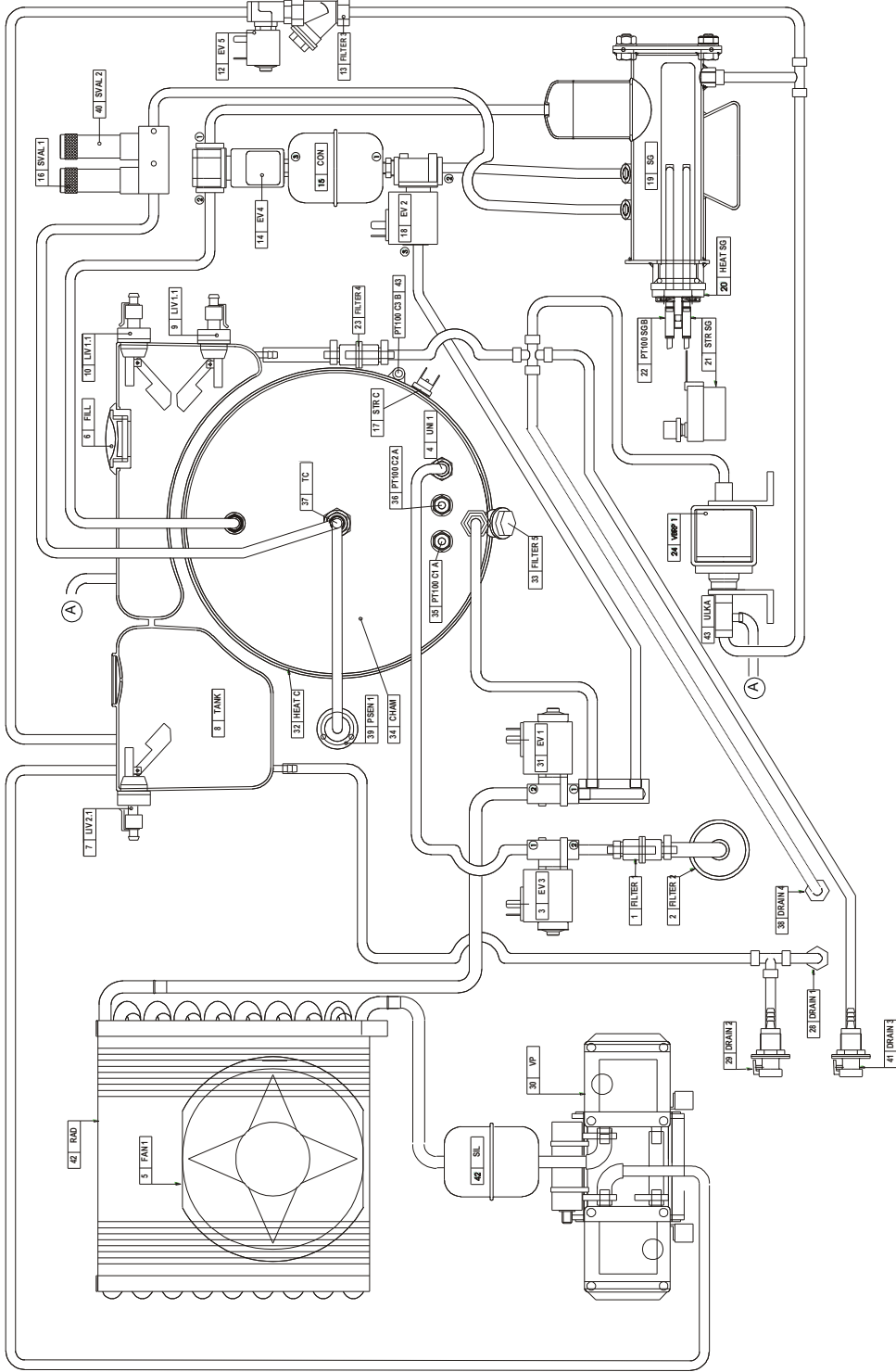



**Hydraulic Circuit Diagram (2 of 2)**

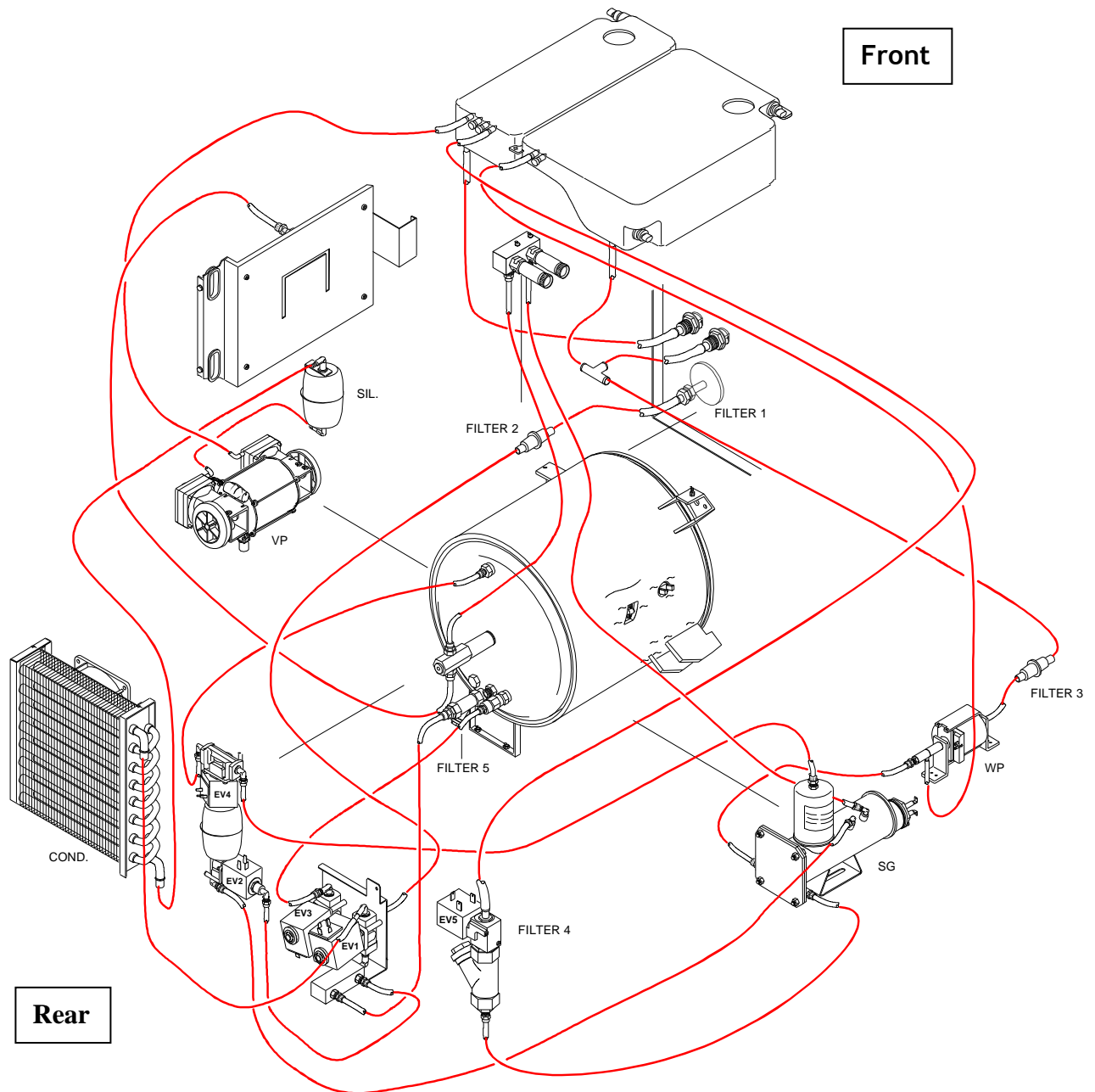



## Section 4 – Testing Prior to Repair

### Vacuum Test

Use this test to validate the performance of the sterilizer in terms of leakage:

- ▶ The efficiency of the vacuum pump.
- ▶ The tightness of the pneumatic circuit.

The profile of the cycle specific to this test includes:

- ▶ A vacuum phase up to P1 = - 12.3 psi.
- ▶ A stabilization period of 5' => T2. Reading of P2.
- ▶ A testing period of 16' => T'3. Reading of P3.

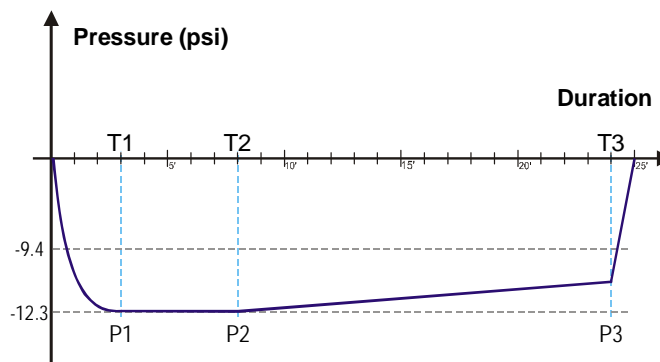

Select and start the Vacuum Test in the **SERVICE** submenu. The test will run for 16 minutes, then display a “pass” or “fail” message.

**Important:** According PrEN13060 norm, a vacuum leak of 0.19 psi/min (0.013 bar/min) or greater is unacceptable. A measurable leak of 0.19 psi/min (0.013 bar/min) will give a “fail” message.

**Bowie & Dick Test**

The Bowie & Dick Test (also called Brown Test) is representative of the small porous type load. It comprises several sheets of paper and foam wrapped in a small packet in the middle of which there is a chemical heat-sensitive indicator strip (physic-chemical test). This test is used to validate the equipment performance in terms of textile load sterilization, i.e.:

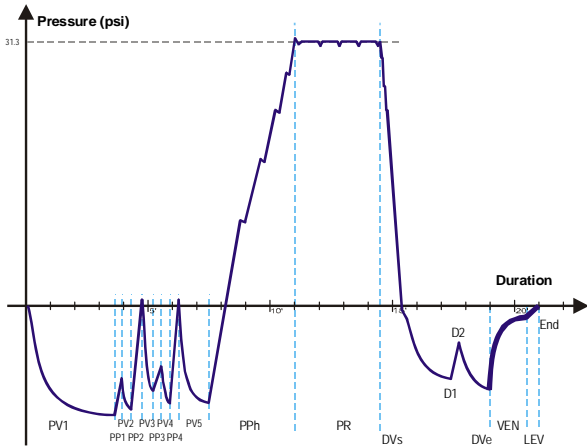

- ▶ Pre-vacuum efficiency and thus steam penetration.
- ▶ Temperature and pressure parameters of the saturated steam during the holding time.

The cycle profile is identical to that of other cycles with:

- ▶ a temperature of 275.9°F (135.5°C).
- ▶ a pressure of 31.3 psi.
- ▶ a sterilization plateau of 3 min 20 sec guaranteeing a security margin.
- ▶ a drying time of 4 min to prevent false results.

To run the test:

Place the Bowie & Dick Test (complete packet) on the lower tray of the chamber, with the label facing upwards.

Select and start the B&D cycle from the **SERVICE** submenu.

Note: You can enter your name, the date, cycle number and sterilizer number, on each test for filing purposes.

Once the cycle is completed, open the door and remove the test.

Caution: the packet will be very hot.

Remove the indicator strip from the center of the packet.



Correct result:  
The radial strips have  
turned black.



Incorrect result:  
The central part is not the  
same color as the edges.

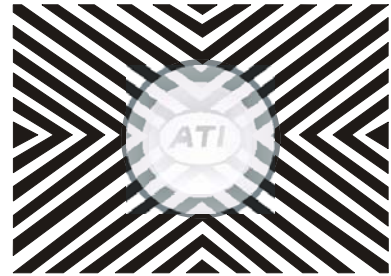

The result is also incorrect, if the indicator is gray or silver (over-exposure, i.e. excessive temperature).

### Accessing the Diagnostic Screens

The **DIAGNOSTIC** menu allows you to check every single component of the sterilizer without running a complete cycle. This is useful during troubleshooting.

To access the **DIAGNOSTIC** menu:

1. In the **SERVICE** submenu, select **DIAGNOSTIC**. Press **OK** to confirm your selection.

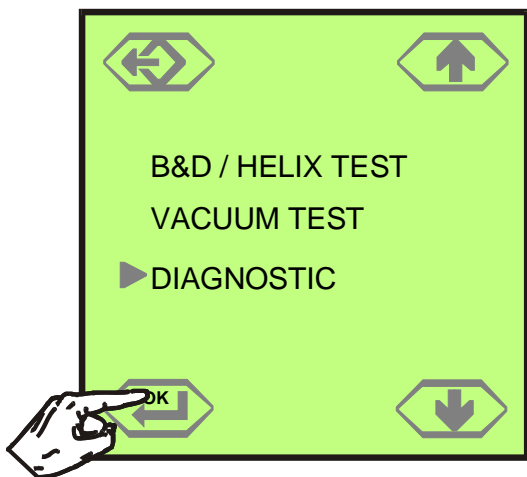

2. Consecutively press **1**, **2**, **3** and **4** icons. The first test screen displays.

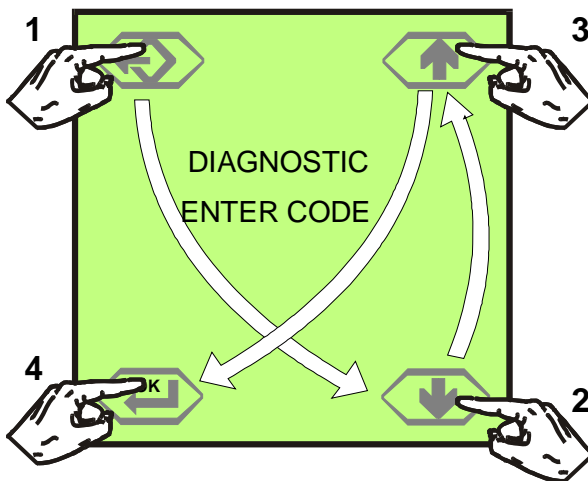

**Screens 1 and 2**

Use screens 1 and 2 to select and test all components.

1. Select the item to be tested and press **OK**. The component will be powered for 8 seconds and released.
2. Select a second item to be tested or select **NEXT** to go to screen 2 and press **OK**. If you want to exit the test screens, press **BACK**.
3. On screen 2, select the item to be tested and press **OK**. If you want to go to screen 3, select **NEXT** and press **OK**.

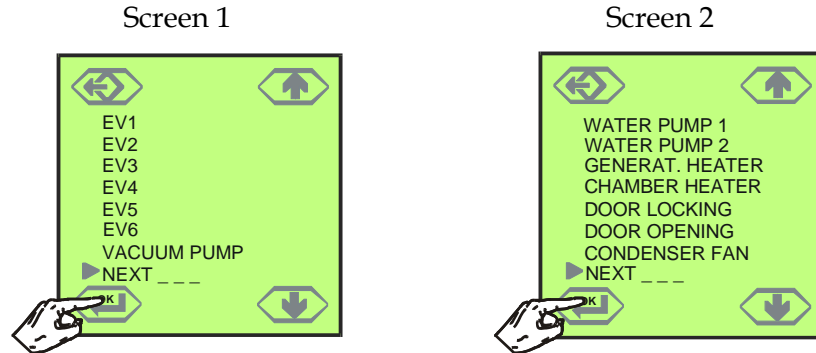

**Screen 3**

Use screen 3 to set the pressure and temperature units.

Select **PRESSURE UNIT** or **TEMPERATURE UNIT** to be set and press **OK**.

Select the unit desired and press **OK**.

Press **BACK** to go to previous screen, select a second parameter to set, or select **NEXT** to go to screen 4 and press **OK**.

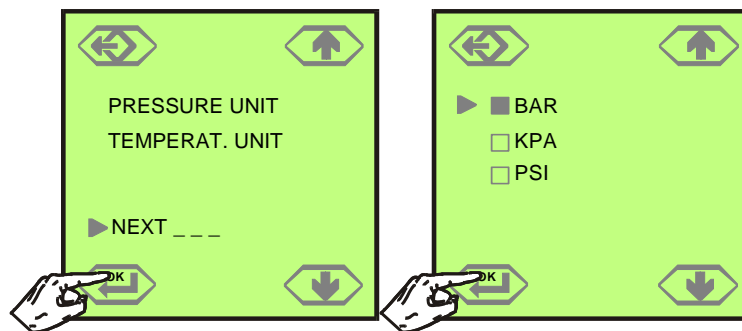

3. Use **UP** or **DOWN** to select the temperature unit.

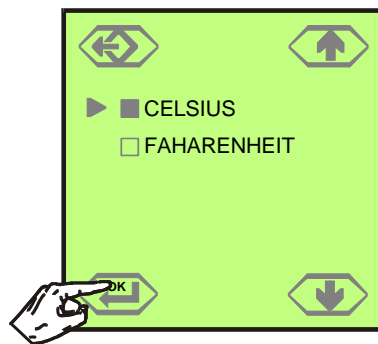

4. Press **OK** to confirm your selection, or press **BACK** to return to the previous screen.



**Accessing Screen 4**

The hardware key is required to modify functions on the 4th screen. Connect the hardware safety key to the serial port located behind the service door, as shown below.

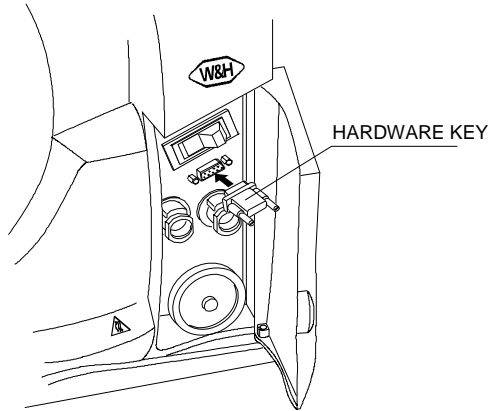

**Loop Cycles Function**

Use the Loop Cycles function to run unlimited consecutive cycles. Both water tanks must be connected together to recycle the water.

- ▶ Select LOOP CYCLES from screen 4 and press OK to run the cycle to be tested. Use a manual stop to interrupt the test.

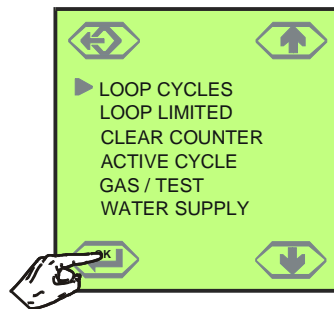

**Loop Select Function**

Use the LOOP SELECT function to run a limited number of consecutive cycles. Both water tanks must be connected together to recycle the water.

1. Select LOOP SELECT from screen 4 and press OK.

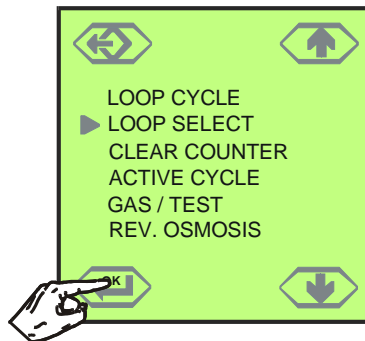

2. Set the number of cycles to be run.

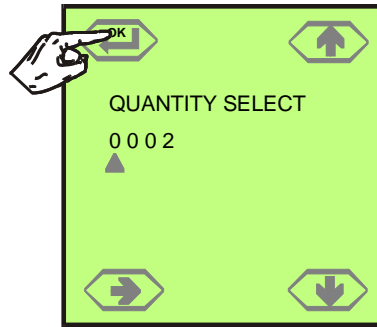

3. Use the side arrow icon to move the cursor under the desired digit and change the number by using the arrow keys.
4. Press **OK** and return to the previous screen.
5. Run the cycle to be tested. Use a manual stop to interrupt the test.

### Clear Counter Function

Use the Clear Counter function to reset the cycle counter.

1. Select CLEAR COUNTER from screen 4 and press **OK**.

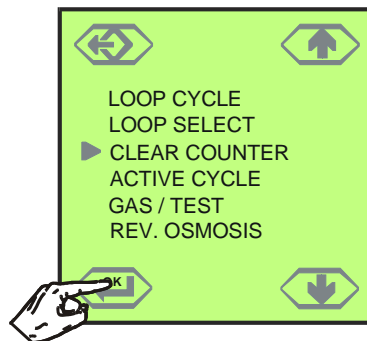

2. Press **BACK** to quit without resetting the counter. Press **OK** to reset the counter and return to the previous screen.

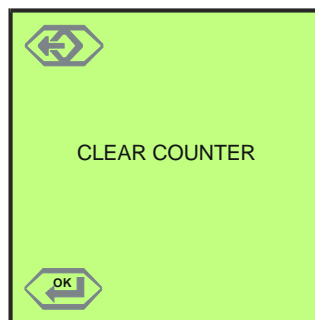

**Active Cycle Function**

Use the ACTIVE CYCLE function to enable and disable cycles.

1. Select ACTIVE CYCLE from screen 4 and press **OK**.

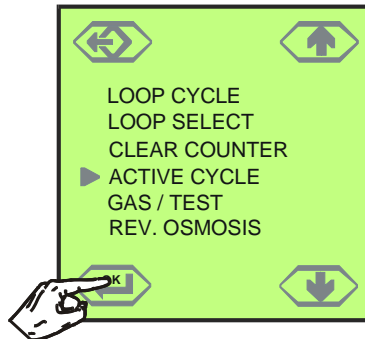

2. On the resulting screen, the black and white squares show the enabled and disabled cycles, respectively.

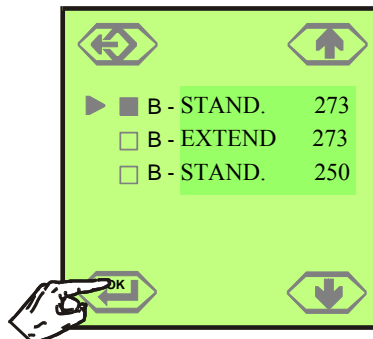

3. To modify a status, select the desired cycle then press **OK**. Press **BACK** to go to the previous screen.

**Gas/Test Function**

Use the GAS/TEST function to download the chamber steam content during the PR phase, to evaluate the proportion of non-condensable gases respective to the condensed steam volume (<3.5%).

- ▶ Select GAS TEST from screen 4 and press **OK**.

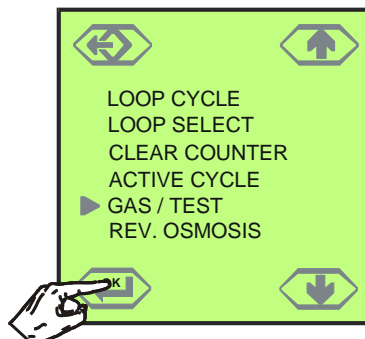

**Rev. Osmosis Function**

Use the REV. OSMOSIS function to configure the external water supply.



## Section 5 – Troubleshooting

### Alarm Classification

Alarms and concerns are classified in sections related to potential sources, and are organized by alarm code similarly to integrated diagnostic functions displayed on the sterilizer touchscreen.

<b>Alarm/Concern Code</b>	<b>Functional area/Problems</b>
01	Power supply
02	Aesthetic concerns
03	Printer
04	Sterilization concerns
05	Drying concerns
06	Condenser subset
07	Water tanks
08	Touchscreen
09	CPU board
10	Sterilization chamber
20	Steam generator
30	Vacuum pump
40	Water pump
50	Door locking system
60	Electro-valves
70	Distilled/de-mineralized water concerns

Troubleshooting tables are organized as follows:

1 <sup>st</sup> Column	The alarm code displayed on the touchscreen; the concern.
2 <sup>nd</sup> Column	Description of alarm/anomaly.
3 <sup>rd</sup> Column	Possible causes of the alarm/anomaly.
4 <sup>th</sup> Column	Related action to solve the problem.
5 <sup>th</sup> Column	Related procedures and layouts (where applicable).

	CODE	DESCRIPTION	SEL	PV1..	PP1..	PV6	PPh	PR	DV	VEN	LEV	End	
230	A01	Power failure		✓	✓	✓	✓	✓	✓	✓	✓		
CHAMBER	A10	If duration of PPh phase > 20 minutes					✓						
	A11	T° chamber heater > Set + 72°F (40°C)		✓	✓	✓	✓	✓	✓	✓	✓	✓	
	A12	T° chamber heater < Set - 72°F (40°C)		✓	✓	✓	✓	✓	✓	✓	✓	✓	
	A13	T° theoretical > 278.6°F (33.4 psi)/255.2°F (18.0 psi) T° theoretical > 137°C (2.3 bar)/124°C (1.24 bar)						✓					
	A14	T° theoretical < 273.2°F (29.4 psi)/249.8°F (15.1 psi) T° theoretical > 134°C (2.03 bar)/121°C (1.04 bar)						✓					
	A15	T° sen < 273.2°F/249.8°F (Steam temperature) T° sen < 101°C/121°C (Steam temperature)						✓					
	A16	T° sen > 278.6°F/255.2°F (Steam temperature) T° sen > 137°C/124°C (Steam temperature)						✓					
	A17	External chamber sensor open (Jacket heater)	✓	✓	✓	✓	✓	✓	✓	✓	✓	✓	✓
	A18	Internal chamber sensor broken	✓	✓	✓	✓	✓	✓	✓	✓	✓	✓	✓
	STEAM GENERATOR	A21	Steam generator temperature > Set + 126°F (70°C)		✓	✓	✓	✓	✓				
A22		Steam generator temperature below 194°F (90°C)		✓	✓	✓	✓	✓					
A23		Steam generator sensor broken	✓	✓	✓	✓	✓	✓	✓	✓	✓	✓	
VACUUM	A31	3 minutes after beginning of the phase: Pressure > -2.9 psi (-0.2 bar)		✓		✓			✓				
	A32	4 minutes after beginning of the phase: Pressure > -7.2 psi (-0.5 bar)		✓		✓							
	A33	The value of the 6 <sup>th</sup> vacuum pulse to be run < -11.6 psi (-0.8 bar)		✓ PV5									
	A34	The 10 last cycles required the 6 <sup>th</sup> additional vacuum pulse										✓	
DOOR	A52	Door locking problem/ DOOR LOCKED switch open		✓	✓	✓	✓	✓	✓	✓	✓	✓	
VALVES	A63	2 minutes 50 seconds after beginning of the phase: Pressure < -10.1 psi (-0.7 bar)			✓		✓						

## 01 Power Supply

Alarm or concern	Description	Cause	Action	Procedures Layouts
A01	Mains failure or significant fall in voltage		The cycle must be repeated	
	Touchscreen OFF and main switch LED illuminated	CPU board fuses	Check and replace the broken fuses	
		Touchscreen broken	Replace the touchscreen	<b>Proc. 5</b>
	Mains voltage OK + Main switch LED not illuminated when activated + Touchscreen OFF	Mains filter pack fuses broken	Replace the main filter pack	<b>Proc. 12</b>

The load cannot be considered sterile; the cycle must be repeated.

**02 Aesthetic Concerns**

Concern description	Cause	Action	Procedures Layouts
<b>Composite fascia/door cover/technical door broken</b>	Use of aggressive cleaning solutions	Replace the part(s) and check attached product list indicating products not to be used	<b>Proc. 2, 4, and 30</b>
<b>After replacement door cover touches the fascia</b>	Door cover has to be adjusted to fit the cast aluminum door	File down the left hand lower part of the cover until door cover/fascia contact is avoided	



# Lisa Sterilizer Service Guide Troubleshooting

## 03 Printer \*

Concern Description		Cause	Action	Procedures Layouts
<b>No printout</b>		Printer flat cable	Replace printer flat cable	<b>Proc. 18</b>
		EMC filter	Test without filter, if OK replace it	
		CPU	Replace CPU board	<b>Proc. 17</b>
		Printer itself	Test another type of printer	
<b>Strange printing characters</b>		Wrong printer selection	Select the correct printer Custom or Seiko in the printer submenu	<b>Owner's Manual</b>
		Printer flat cable	Replace printer flat cable	
		EMC filter	Test without filter, if OK replace filter	
<b>Custom DP40</b>	<b>Printout inverted Big characters Wrong width etc.</b>	Wrong printer settings	Set the right parameters using the printer setting mode	<b>Custom setting procedure</b>
	<b>Empty line between each printed one (extended printout)</b>	Wrong driver selected	Select Custom printer instead of Seiko in the <b>PRINTER</b> submenu	<b>Owner's Manual</b>
<b>Seiko</b>	<b>Only one line printed</b>	Wrong driver selected	Select Seiko printer instead of Custom in the <b>PRINTER</b> submenu	<b>Owner's Manual</b>

### Printer Types

ATTENTION: Only 3 printer types can be used with the Lisa sterilizer:

- Custom DP40
- Seiko DPU-414
- CITI70 DP 3110

These printers have been tested and the corresponding drivers are included in the software. The correct printer driver must be selected in the **PRINTER** submenu.

**Configuring the Printer**

If both keys are held down when the printer is switched ON, the printer enters the configuration mode and prints the first modifiable parameter. Each time **PRINT** is pressed, the variation of the parameter is shown and its current value is printed. After entering the desired parameter, press **FEED** to go to the next parameter. Once all parameters have been entered, the printer prints a message to indicate the setting procedure has been completed.

Recommended printer parameters:

PRINT = REVERSE  
LITTLE  
FONT 1  
CR-LF HONOR CR  
PARALLEL MODE  
8 BITS PER CHAR.  
TEXT = DISABLE

## 04 Sterilization Concerns

<b>Alarm or concern</b>	<b>Description</b>	<b>Cause</b>	<b>Action</b>	<b>Procedures Layouts</b>

**05 Drying Problems**

Concern description	Cause	Action	Procedures Layouts
<p><b>Concern due to load preparation and/or loading mistakes</b></p>	Incorrect loading	Place the paper side upward.	<p><b>Preparation of the load</b></p>
	Over loaded chamber	Do not exceed maximum load masses of 4.5 and 1.5Kg (9.9 and 3.3lbs) respectively for solid and porous loads.	
	Instruments not dried prior to sterilization	The load must be rinsed and dried.	
	Trays/cassettes not perforated	Use only perforated accessories.	
	Miscellaneous: check preparation, loading, wrapping, bags, material , etc.		
<p><b>Mechanical concerns</b></p>	Vacuum pump	Assure the vacuum pump operates during the drying phase. If the pump operates, check the filter.	<p><b>Owner's Manual</b></p>
	Filter	Try a cycle without a filter. If OK, replace the filter.	
	Condenser fan	Determine if the fan is working at the maximum speed, if not replace it.	<p><b>Diagnostic menu</b></p>
	<p>Excessive water consumption &gt; 0.42 quart/cycle &gt;0.4 liters/cycle</p>	Check steam generator PT100 positioning/condition.	<p><b>Proc. 39</b></p>
		Determine if the 2CS condensation re-vaporization (EV2/EV4) system is working properly. Clean chamber filter (filter 5).	<p><b>See Section 1</b></p>
		Assure the worksurface under the sterilizer is level.	
Check EV1 tightness especially during PR phase, replace if needed.		<p><b>Proc. 26</b></p>	

# **Lisa Sterilizer Service Guide Troubleshooting**

---

## **EN 13060 : Dryness Test Procedure**

Weigh the test load and record its mass (m1).

Place the test load in the sterilization chamber in a position which allows the load to acquire the maximum moisture.

Immediately start the sterilization cycle.

At the completion of the sterilization cycle, remove the test load from the sterilizer chamber.

Visually check the test load. No moisture spots should be visible on the test load or the wrapping material.

Weigh the test load within 2 minutes of the cycle completion. Record the mass (m2).

Calculate the change in moisture content CMC using the following formula:  $CMC = \frac{m2-m1}{m1} \times 100\%$

## **EN 13060 "Small Steam Sterilizer Standard" Drying Tolerance Definitions**

For wrapped loads, any remaining moisture shall not lead to wet packages and shall not result in detrimental effects on the sterilization load. Any remaining water droplets on the inner side of the film of laminate pouch shall evaporate within 5 minutes.

For a solid load the moisture content (CMC) shall not exceed 0.2 % when tested.

For a porous load the moisture content (CMC) shall not exceed 1.0 % when tested.

## **Load Preparation (from Owner's Manual - Annex 2)**

### **Cleaning of the instrument**

- ▶ The instruments to be sterilized must be clean and free from all types of residue such as fragments, dentine, and blood, etc. These substances can damage the objects on the trays and the sterilizer.
- ▶ Clean the instruments immediately after use. Follow the manufacturer's instructions when using an ultrasonic cleaner.
- ▶ Remove all traces of disinfectant from the product as this may cause corrosion on heating. Rinse thoroughly, and then dry.
- ▶ Lubricate in accordance with the manufacturer's instructions.

### **Preparation of the trays**

- ▶ Do not exceed the maximum load which has been set, tested and validated by the manufacturer.
- ▶ Always use the rack to allow adequate steam circulation between the trays.
- ▶ Do not overload the trays.
- ▶ Place the cassettes in the vertical position (if possible) to ensure thorough drying.
- ▶ Place the items in such a way so as to allow the steam to circulate properly.

- ▶ Empty containers or non-perforated trays must be placed upside down to prevent accumulation of water.
- ▶ Items made from different materials (stainless steel, carbon, etc.) must be placed on separate trays.
- ▶ Instruments manufactured from carbon steel, should have paper placed between them and the sterilizer tray.
- ▶ Sterilize instruments in the open position, e.g. forceps.
- ▶ In the case of wrapped items, use porous packaging to facilitate good steam penetration and drying (e.g. nylon/paper sachet for autoclave).

### **Tubes**

- ▶ Rinse, drain and dry after washing.
- ▶ Place the tubes on a tray allowing the ends to remain open. Do not bend.

### **Packets**

- ▶ Place the packets in the vertical position, leaving a space between each one. Do not allow them to come into contact with the walls of the sterilization chamber.

### **Wrapped material**

- ▶ Bags should be placed on trays, leaving a space between each one. Position with paper side upwards.

## **06 Condenser Subassembly**

<b>Alarm or concern</b>	<b>Description</b>	<b>Cause</b>	<b>Action</b>	<b>Procedures Layouts</b>
<b>Fan</b>	<b>Fan noisy at low speed</b>	The fan is out of balance	Replace the fan	<b>Proc. 23</b>

## 07 Water Tanks

Alarm or concern	Description	Cause	Action	Procedures Layouts
<b>Pure water tank overflows during filling (no acoustic signal)</b>		Maximum pure water level sensor	Make sure the sensor moves freely ----- Remove, check, replace the sensor ----- Check connections and wiring loom	<b>Proc. 9</b>
<b>Used water tank overflows (no warning message)</b>		Maximum used water level sensor	Make sure the sensor moves freely ----- Remove, check, replace the sensor ----- Check connections and wiring loom	<b>Proc. 9</b>
<b>Used water tank cannot be drained</b>		Tubing blocked	Make sure the steam generator heating element is coated. If not : replace it ----- Clean the tubing and try to find out where the debris came from (load not cleaned, water quality, etc.) <u>Reminder</u> : If the sterilizer is not used for more than 1 week, both water tanks must be completely drained in order to avoid algae growth or any other deposits.	<b>Proc. 15</b>  <b>Annex 2 and 3 of the Owner's Manual</b>
<b>Water droplets come out of the used water tank venting holes</b>	In case of intensive use, this phenomena is normal especially when the tank is nearly full	Maximum used water level sensor	Make sure the sensor moves freely ----- Remove, check, replace the sensor ----- Check connections and wiring loom	<b>Proc. 9</b>



# Lisa Sterilizer Service Guide Troubleshooting

## 08 Touchscreen

Alarm or concern	Description	Cause	Action	Procedures Layouts
<b>Touchscreen not working</b>		EMC protection film	Replace the EMC film	<b>Proc. 5</b>
		Touchscreen itself	Replace the touchscreen	
		Touchscreen flat cable	Replace the touchscreen	
		CPU board	Check fuses Replace the CPU board	<b>Sec. 3, Tab 15</b> <b>Proc. 17</b>
<b>Continuous scrolling of the screen</b>		EMC protection film	Replace the EMC film	<b>Proc. 5</b>
		Touchscreen itself	Replace the touchscreen	
		Touchscreen flat cable connector	Replace the touchscreen	
<b>LCD Display</b>	<b>A few dots or lines are missing</b>	Touchscreen itself	Replace the touchscreen	<b>Proc. 5</b>
	<b>Screen completely dark</b>	LCD contrast	Adjustment of the contrast in <b>Touchscreen</b> submenu	
		Touchscreen itself	Replace the touchscreen	<b>Proc. 5</b>
	<b>Screen completely light or blank</b>	LCD contrast	Adjustment of the contrast in <b>Touchscreen</b> submenu	
		CPU board	Check jumper X7 position	<b>Layout 22</b>
			Check fuses/replace CPU	<b>Proc. 17</b>
		Touchscreen itself	Replace the touchscreen	<b>Proc. 5</b>
Touchscreen connections	Check TS/CPU connections			
	Check the flat cable condition			

**09 CPU Board**

<b>Alarm or concern</b>	<b>Description</b>	<b>Cause</b>	<b>Action</b>	<b>Procedures Layouts</b>
<b>Press. + T° calibration cancelled</b>	<b>Condensation/ moisture from the used water tank negatively affects the electronic components</b>	Determine if the new tank/cover with grommets' seals are fitted, if not, replace both	Replace both water tank and cover	<b>Proc. 9</b>
		Check the grommet's condition and positioning (sealing)	Fix the grommets properly Replace the grommets if damaged	<b>Proc. 1</b>
	<b>Droplets from the pressure sensor connection negatively affects the electronic components (EPROM)</b>	Remove the tubing, cut 5mm (1/4 in.) and re-fix tightly		
	<b>Water penetration during the tank filling</b>	Mount the additional gasket under the front fascia		<b>Proc. 36</b>
<b>Stored data (Date, Name, LCD adjust., etc.) cancelled</b>	<b>Condensation/ moisture from the used water tank negatively affects the electronic components</b>	Determine if the new tank/cover with grommets' seals are fitted, if not, replace both	Replace both water tank and cover	<b>Proc. 1 and 9</b>
		Check the grommet's condition and positioning (sealing)	Fix the grommets properly Replace the grommets if damaged	
	<b>Droplets from the pressure sensor connection negatively affects the electronic components (EPROM)</b>	Remove the tubing, cut 5mm (1/4 in.) and re-fix tightly		
	<b>Water penetration during the tank filling</b>	Mount the additional gasket under the front fascia		<b>Proc. 36</b>

## 10 Sterilization Chamber

Alarm or concern	Description	Cause	Action	Procedures Layouts
<b>A10</b>	<p><b>PPh phase duration greater than 20 minutes</b></p> <p>The nominal sterilization holding time pressure:</p> <p>16.5 psi (1.14 bar) at 250°F (121°C) or 31.3 psi (2.16 bar) at 273°F (134°C)</p> <p>could not be reached within 20 minutes during PPh phase</p>	Main water tank empty	Check minimum water level sensor	
		Excessive water consumption >14 oz./cycle >0.4 liter/cycle	Check steam generator PT100 positioning/condition	<b>Layout 45</b>
			Determine if the 2CS condensation re-vaporization (EV2/EV4) system is working properly Clean chamber filter (FILTER 5)	<b>See Section 1</b>
			Check sterilizer leveling	
			Check EV1 tightness especially during PR phase, replace if needed	<b>Proc. 26</b>
		Insufficient water injected into the steam generator	Check water pump (WP)	<b>Layout 21</b>
			Check water pump one way valve condition	
			Check water filter condition (FILTER 3) Check braided black tubing positioning/fixing (twisted/clamped)	
		Significant leakage	Check door seal / door adjustments	<b>Layout 7, 12 and 13</b>
			Check over pressure safety valves	<b>Layout 25</b>
Check pneumatic connections				

<b>Alarm or concern</b>	<b>Description</b>	<b>Cause</b>	<b>Action</b>	<b>Procedures Layouts</b>
<b>A11</b>	<p><b>Chamber heater temperature &gt; Set + 72°F (40°C)</b></p> <p>The temperature of the chamber heater element is above the set value</p>	External T° sensor PT100	Check condition, position, fastening of the external PT100 T° sensor	<b>Layout 27</b>
		CPU board calibration cancelled	CPU calibration	<b>Layouts 22 and 23</b>
		CPU board broken	CPU replacement + calibration	<b>Calibration board + service EPROM 1</b>
<b>A12</b>	<p><b>Chamber heater temperature &gt; Set - 72°F (40°C)</b></p> <p>The temperature of the chamber heater is below the nominal value</p>	Chamber thermal-overload open	Reset/replace thermal-overload	<b>Proc. 32</b>
		External T° sensor PT100 broken	Sensor replacement	<b>Proc. 24</b>
		CPU board calibration cancelled	CPU calibration	<b>Layouts 22 and 23</b>
		CPU board	Check the chamber heating element power voltage output on the CPU board, if not, replace the CPU board	<b>Calibration board + service EPROM 1</b>
<b>A13</b>	<p><b>Theoretical temperature &gt; 278.6°F/255.2°F &gt;137°C/124°C</b></p> <p><b>Pressure &gt; 33.4 psi/18.0 psi &gt; 2.30 bar/ 1.24 bar</b></p> <p>During PR phase, theoretical T° deducted from read pressure, (according saturated steam T°/ P correlation table), is above the maximum threshold</p>	CPU board broken	CPU replacement + calibration	<p><b>Layouts 22 and 23</b></p> <p><b>Calibration board + service EPROM 1</b></p>

# Lisa Sterilizer Service Guide Troubleshooting

Alarm or concern	Description	Cause	Action	Procedures Layouts
<b>A14</b>	<p><b>Theoretical temperature</b>                      &lt; 273.2°F/249.8°F                      &lt; 134°C/ 121°C</p> <p><b>Pressure</b>                      &lt; 29.4 psi/15.1 psi                      &lt; 2.03 bar/1.04 bar</p> <p>During holding time, the theoretical T° deducted from read pressure, according saturated steam T°/ P correlation table, is below the minimum threshold</p>	Main water tank empty	Check minimum water level sensor	<b>Layout 9</b>
		Excessive water consumption > 14 oz./ cycle > 0.4 liters/cycle	Check steam generator PT100 positioning/condition	<b>Layout 45</b>
			Determine if the 2CS condensation re-vaporization (EV2/EV4) system is working properly	<b>See Sec. 1</b>
			Clean chamber filter (FILTER 5)	<b>Proc. 37</b>
		Insufficient water injected into the steam generator	Check sterilizer work surface for level	
			Check EV1 tightness especially during PR phase, replace if needed	<b>Proc. 26</b>
		Significant leakage	Check water pump (WP)	<b>Layout 21</b>
			Check water pump one way valve	
			Check water filter condition (FILTER 3)	
			Check door seal/door adjustments	<b>Layouts 7, 12 and 13</b>
Check over pressure safety valves				
Check pneumatic connections				
<b>A15</b>	<p><b>T° sen</b>                      &lt; 273.2°F/ 249.8°F                      &lt; 134°C/ 121°C  <b>(Steam temperature)</b></p> <p>During holding time, the steam temperature read is below the minimum threshold</p>	Internal PT100 T° sensor	Check internal PT100 T° sensor condition and positioning	<b>Layout 37</b>
		Main water tank empty	Check minimum water level sensor	<b>Layout 9</b> <b>Proc. 9</b>
		Excessive water consumption > 14 oz./cycle > 0.4 liters/cycle	Check steam generator PT100 positioning/condition	<b>Layout 45</b>
			Determine if the 2CS re-vaporization (EV2/EV4) system works properly	<b>See Sec. 1</b>
			Clean chamber filter (FILTER 5)	<b>Proc. 37</b>
			Check sterilizer work surface for level	

<b>Alarm or concern</b>	<b>Description</b>	<b>Cause</b>	<b>Action</b>	<b>Procedures Layouts</b>
<b>A15 continued</b>	<b>T° sen &lt; 273.2°F/249.8°F &lt; 134°C/ 121°C (Steam temperature)</b>  During holding time, the steam temperature read is below the minimum threshold		Check EV1 tightness especially during PR phase, replace if needed	<b>Layout 32</b>
		Insufficient water injected into the steam generator	Check water pump (WP)	<b>Layout 21</b>
			Check water pump one way valve	
			Check water filter condition (FILTER 3)	
		Significant leakage	Check door seal/door adjustments	<b>Layouts 7, 12 and 13</b>
			Check over pressure safety valves	<b>Layout 25</b>
	Check pneumatic connections			
	CPU board calibration cancelled	CPU calibration	<b>Layouts 22 and 23</b> <b>Calibration board + service EPROM 1</b>	
<b>A16</b>	<b>T° sen &gt; 278.6°F/ 255.2°F &gt; 137°C/ 124°C (Steam temperature)</b>  During holding time, the steam temperature read is above the maximum threshold	Significant leakage	Check door seal/door adjustments	<b>Layouts 7, 12 and 13</b>
			Check over pressure safety valves	<b>Layout 25</b>
			Check pneumatic connections	
		Internal PT100 T° sensor	Check internal T° sensor condition and positioning	<b>Layout 37</b>
		External PT100 T° sensor	Check external T° sensor condition and positioning	<b>Layout 27</b>
		CPU board calibration cancelled	CPU calibration	<b>Layout 22</b> <b>Calibration board + service EPROM 1</b>

# Lisa Sterilizer Service Guide Troubleshooting

<b>Alarm or concern</b>	<b>Description</b>	<b>Cause</b>	<b>Action</b>	<b>Procedures Layouts</b>
<b>A17</b>	<b>Chamber heater temperature sensor broken</b> The chamber external PT100 T° sensor is broken or disconnected	External PT100 T° sensor	Check PT100 T° sensor connections	<b>Proc. 24</b>
			Replace PT100 T° sensor	
<b>A18</b>	<b>Internal chamber temperature sensor broken</b> The chamber internal PT100 T° sensor is broken or disconnected	Internal PT100 T° sensor	Check PT100 T° sensor connections	<b>Proc. 31</b>
			Replace PT100 T° sensor	

## 20 Steam Generator

Alarm or concern	Description	Cause	Action	Procedures layouts
<b>A21</b>	<p><b>Steam generator temperature &gt; Set + 126°F (70°C)</b></p> <p>The temperature of the steam generator is above the maximum threshold</p>	Main water tank empty	Check minimum water level sensor	<b>Proc. 9</b>
		Excessive water consumption >14 oz./cycle (>0.4 liters/cycle)	Check steam generator PT100 positioning/condition	<b>Layout 45</b>
			Determine if the 2CS condensation re-vaporization (EV2/EV4) system is working properly	<b>See Section 1</b>
			Clean chamber filter (FILTER 5)	<b>Proc. 37</b>
			Check sterilizer leveling	
		Check EV1 tightness especially during PR phase, replace if needed	<b>Proc. 26</b>	
		Insufficient water injected into the steam generator	Check water pump (WP)	<b>Layout 21</b>
Check water pump one way valve condition				
Check water filter (FILTER 3)				



## Lisa Sterilizer Service Guide Troubleshooting

Alarm or concern	Description	Cause	Action	Procedures layouts
<b>A22</b>	<b>Steam generator temperature &lt; 194°F (90°C)</b>  The temperature of the steam generator is below the minimum threshold	Steam generator thermal overload open after overheating (A21)	Reset the thermal overload and check causes and actions as described in <b>A21</b>	<b>Layout 29</b>
		CPU board	Check the steam generator heating element power voltage output on the CPU board, if none, replace the CPU board	<b>Proc. 17</b> <b>Diagnostic menu</b>
		Steam generator heating element	Check the conductivity of the heating element with an ohmmeter, if open replace the heating element	<b>Proc. 15</b>
		CPU board steam generator T° channel calibration cancelled provoking overheating and the thermal overload opening	CPU calibration	<b>Layout 22</b> <b>Calibration board + service EPROM 1</b>
<b>A23</b>	<b>Steam generator temperature sensor broken</b>  The steam generator PT100 T° sensor is broken or disconnected	Steam generator T° sensor	Check PT100 sensor connections ----- Replace PT100 sensor	<b>Proc. 39</b>
		CPU board steam generator T° channel calibration cancelled	CPU calibration	<b>Layout 22</b> <b>Calibration board + service EPROM 1</b>

### 30 Vacuum Pump

Alarm or concern	Description	Cause	Action	Procedures Layouts
<p><b>A31</b></p>	<p><b>3 minutes after phase start: Pressure &gt; -2.9 psi (-0.20 bar)</b></p> <p>During a vacuum <i>phase</i> (PV1-6/DV), the lowest achieved pressure/vacuum is not below -2.9 psi (-0.20 bar)</p>	<p>Vacuum pump</p>	<p>Check vacuum pump condition, pneumatic and electrical connections</p>	<p><b>Layout 33</b></p>
			<p>Check vacuum pump head membranes, valves and O-rings</p>	
		<p>Pressure sensor</p>	<p>Black braided tubing jammed Pressure sensor broken, replace CPU board</p>	<p><b>Layout 23</b></p>
		<p>CPU board</p>	<p>Check the vacuum pump power voltage output on the CPU board. If none, replace the CPU board</p>	<p><b>Layout 23</b> <b>Diagnostic menu</b></p>
		<p>Door seal</p>	<p>Check door seal condition (broken)</p>	<p><b>Layouts 14, 15, and 16</b></p>
			<p>Door seal not properly positioned against chamber collar: Check door locking system function Check door locking switches adjustment and condition</p>	
		<p>Electro-valves</p>	<p>Check EV2-3-4 tightness and switching</p>	<p><b>Diagnostic menu</b></p>
			<p>Replace Electro-valve(s)</p>	<p><b>Proc. 20 and 26</b></p>
			<p>Replace CPU board</p>	<p><b>Proc. 17</b></p>

## Lisa Sterilizer Service Guide Troubleshooting

Alarm or concern	Description	Cause	Action	Procedures Layouts
<b>A32</b>	<p><b>4 minutes after phase start: Pressure &gt; -7.2 psi (-0.50 bar)</b></p> <p>During a vacuum phase (PV1-6/DV), the lowest achieved pressure/vacuum is not below -7.2 psi (-0.50)</p>	Vacuum pump	<p>Check vacuum pump condition, pneumatic and electrical connections</p> <p>Check vacuum pump head membranes, valves and O-rings</p>	<b>Layout 33</b>
		Door seal	Check door seal condition	
		Condenser fan	<p>Fan stopped or blocked</p> <p>Check the voltage output from the board and on the fan pins:</p> <p>If yes: replace the fan</p> <p>If not: replace the CPU board</p>	<p><b>Diagnostic menu</b></p> <p><b>Proc. 17 and 23</b></p>
		Electro-valves	Check EV2-3-4 tightness and switching, replace electro-valve(s)	<p><b>Diagnostic menu</b></p> <p><b>Proc. 20 and 26</b></p>
		Pneumatics circuit leakage	Check all pneumatic connections	

<b>Alarm or concern</b>	<b>Description</b>	<b>Cause</b>	<b>Action</b>	<b>Procedures Layouts</b>
<b>A33</b>	<p><b>The value of the 6<sup>th</sup> vacuum pulse to be run &lt; -11.6 psi (-0.80 bar)</b></p> <p>The global vacuum level obtained after 5 vacuum pulses was not sufficient and the compensating additional 6<sup>th</sup> calculated pulse cannot be reached</p>	Vacuum pump	<p>Check vacuum pump condition, pneumatic and electrical connections</p> <p>Check vacuum pump head membranes, valves and O-rings</p>	<b>Layout 33</b>
		Condenser fan	<p>Fan stopped or blocked. Check the voltage output from the board and on the fan pins:</p> <p>If yes: replace the fan</p> <p>If not: replace the CPU board</p>	<b>Proc. 17 and 23</b>
		Door seal	Check door seal condition	
		Electro-valves	Check EV2-3-4 tightness and switching, replace electro-valve(s)	<b>Diagnostic menu</b> <b>Proc. 20 and 26</b>
		Pneumatics circuit leakage	Check all pneumatic connections	
		CPU board calibration cancelled	CPU calibration	<b>Layout 22</b> <b>Calibration board + service EPROM 1</b>
<b>A34</b>	<p><b>The 10 last cycles required the 6<sup>th</sup> additional vacuum pulse</b></p> <p>Sterilization is guaranteed. The additional 6<sup>th</sup> pulse ensures the required vacuum level. The user can go on sterilizing but will get a new alarm within 10 new cycles.</p>	Overloaded cycle	Refer to the cycle table for the maximum solid and porous load mass	
		<b>FOLLOW A33</b>		

# Lisa Sterilizer Service Guide Troubleshooting

## 40 Water Pump

Concern description	Cause	Action	Procedures Layouts
<b>Water pump is noisy</b>	One way valve spring	Check one way valve spring adjustment	<b>Layout 41</b>
	Pump itself	Check pump fixing/positioning	
		Check rubber support condition	
		Check braided black tubing positioning/fixing (twisted)	
	Replace the water pump		<b>Diagnostic menu</b> <b>Proc. 16</b>
<b>Water pump doesn't work</b>	Pump connections	Check pump/CPU electric connections (inverted wires)	<b>Diagnostic menu</b>
	Pump itself	Replace the water pump	<b>Proc. 16</b>
	CPU board	Check the water pump power voltage output on the board. If not: replace the CPU board	<b>Diagnostic menu</b> <b>Proc. 17</b>

## 50 Door Locking System

Alarm or concern	Description	Cause	Action	Procedures Layouts
<p>At cycle start, the locking motor is powered until the <b>DOOR LOCKED</b> switch is activated. If within 6" this switch is not reached, the motor is reversed until the <b>UNLOCKED</b> switch is detected.</p> <p>If the switch is reached or not, follow the listed possibilities ❶ or ❷</p>				
<p><b>Message "Door locking problem"</b></p>	<p>❶ <b>The UNLOCKED switch could be detected (system not blocked or did not move)</b></p>	<p>Door seal</p>	<p>Check door seal condition ----- Door seal out of housing</p>	<p><b>Layouts 7</b></p>
		<p>Door locking system</p>	<p>Check/adjust door locking motor consumption</p>	<p><b>Layout 10</b> <b>Door test device</b></p>
		<p><b>DOOR LOCKED</b> switch</p>	<p>Check the presence and condition of the <b>DOOR LOCKED</b> switch actuator</p>	<p><b>Proc. 11</b> <b>Door test device</b></p>
			<p>Check <b>DOOR LOCKED</b> switch adjustment</p>	<p><b>Diagnostic menu</b></p>
			<p>Replace and adjust the door locking switch board</p>	<p><b>Diagnostic menu</b></p>
		<p>CPU board</p>	<p>Check the motor power voltage output on the CPU board, if not, replace the CPU board</p>	<p><b>Diagnostic menu</b> <b>Proc. 17</b></p>
<p>Door locking motor</p>	<p>If the motor is powered and does not move, replace the entire door locking system</p>	<p><b>Proc. 10</b> <b>Diagnostic menu</b> <b>Door test device</b></p>		

# Lisa Sterilizer Service Guide Troubleshooting

Alarm or concern	Description	Cause	Action	Procedures Layouts
<b>A52</b>	<p style="text-align: center;">②</p> <p><b>The UNLOCKED switch could not be detected (system blocked)</b></p>	Door seal	Check door seal condition ----- Door seal out of housing	<b>Layouts 7</b>
		Door locking system	Check door locking motor electrical consumption	<b>Layout 10</b> <b>Door test device</b>
	Note: the door test device can be connected in order to unlock the system (Layout 10)	CPU board	Check the reverse motor power voltage output on the CPU board (relays), if none, replace the CPU board	<b>Proc. 17</b> <b>Diagnostic menu</b> <b>Door test device</b>
	<b>The UNLOCKED switch is opened during the cycle</b>	<b>DOOR UNLOCKED</b> switch	Check the presence and condition of the switch actuator ----- Replace and adjust the door locking switch board	<b>Proc. 11</b> <b>Door test device</b>
Door switch board/CPU		Check door switch board/CPU connections and wiring loom	<b>Door test device</b>	

<b>Alarm or concern</b>	<b>Description</b>	<b>Cause</b>	<b>Action</b>	<b>Procedures Layouts</b>
<b>END</b>	<b>Door remains locked at the end of the cycle</b>  Note: the door test device can be connected in order to unlock the system (Layout 10).	Door switch board/CPU	Moisture on the door switch board, <b>DOOR UNLOCKED</b> switch remains ON ----- Check door switch board/CPU connections and wiring loom	<b>Door test device</b>
		Door locking motor	Check/adjust door locking electrical motor consumption, if broken, replace the entire door locking system	<b>Layout 10</b>  <b>Door test device</b>  <b>Diagnostic menu</b>
		CPU board	Check the reverse motor power voltage output on the CPU board (relays), if none, replace the CPU board	<b>Schedule 16</b>  <b>Door test device</b>  <b>Diagnostic menu</b>
	<b>Door can be opened but the END screen remains displayed</b>	<b>DOOR CLOSED</b> switch remains activated	<b>DOOR CLOSED</b> switch actuating axle blocked. Clean, lubricate or replace it ----- Check <b>DOOR CLOSED</b> switch and actuator conditions/adjustments	<b>Schedule 16</b>  <b>Door test device</b>



## 60 Electro-Valves

Alarm or concern	Description	Cause	Action	Procedures Layouts
<b>A63</b>	<p><b>2 min. 50 sec. after the process switched from a vacuum to a pressure pulse (pp1-5/ pph), pressure is still negative and below -10.1 psi (-0.70 bar)</b></p> <p>Steam has not been injected in the chamber</p>	EV4	Determine if the valve switches when energized, if not, check connection or replace the valve	<p><b>Diagnostic menu</b></p> <p><b>Proc. 20</b></p>
		EV1	Determine if the valve switches when energized, if not, check connection or replace the valve	<p><b>Diagnostic menu</b></p> <p><b>Proc. 26</b></p>
		CPU board	Check the EV1-4 power voltage output on the CPU board, if none, replace the CPU board	<p><b>Diagnostic menu</b></p> <p><b>Proc. 17</b></p>
		Main water tank empty	Check minimum water level sensor	<p><b>Proc. 9</b></p>
		Insufficient water injected into the steam generator	Check water pump (WP)	<p><b>Layout 21</b></p>
Check water pump one way valve condition				
Check water filter (FILTER 3)				
Check braided black tubing positioning/fixing (twisted/clamped)				

## 70 Distilled/De-Mineralized Water

Concern description	Cause	Action	References
<b>White dots on the load, chamber, trays and tray support</b>	Poor water quality	Check water quality. Change to another water supplier	<b>Attached E EN13060</b> <b>Water quality</b>
	Load not rinsed and dried prior to sterilization	Load must be rinsed and dried	<b>Owner's Manual Attached 2</b> <b>Preparation of the load</b>
	Quality of the drying	Follow chapter 05 <b>Drying problems</b>	

### Preparation of the Load (from Owner's Manual - Annex 2)

#### Cleaning of the instrument

The instruments to be sterilized must be clean and free from all types of residue (such as fragments, dentine, and blood, etc.) These substances can damage the objects placed in the trays and can also damage the sterilizer.

- ▶ Clean the instruments immediately after use. Follow the manufacturer's instructions when using an ultrasonic cleaner.
- ▶ Remove all traces of disinfectant from the product as this may cause corrosion on heating. Rinse thoroughly, and then dry.
- ▶ Lubricate in accordance with the manufacturer's instructions.

# Lisa Sterilizer Service Guide Troubleshooting

## Water Quality (EN13060 Annex E)

Suggested maximum limits of contaminants as specified for water used for steam sterilization

Table B.1: Contaminants of condensate and feed water

	<b>Feed water</b>	<b>Condensate</b>
Evaporate residue	10 mg/liter	1.0 mg/kg
Silicon monoxide, SiO <sub>2</sub>	1 mg/liter	0.1 mg/kg
Iron	0.2 mg/liter	0.1 mg/kg
Cadmium	0.005 mg/liter	0.005 mg/kg
Lead	0.05 mg/liter	0.05 mg/kg
Rest of heavy metals, excluding iron, cadmium, lead	0.1 mg/liter	0.1 mg/kg
Chloride	2 mg/liter	0.1 mg/kg
Phosphate	0.5 mg/liter	0.1 mg/kg
Conductivity (at 68°F) (20°C)	15 µs/cm	3 µs/cm
pH value	5 to 7	5 to 7
Appearance	colorless, clean, without sediment	colorless, clean, without sediment
Hardness	0.02 mmol/liter	0.02 mmol/liter
NOTE 1: Do not use water contaminated at levels exceeding those given in this table for steam generation. Contaminated water greatly reduces the working life of a sterilizer and can invalidate the manufacturer's warranty or guarantee.		
NOTE 2: Condensate is produced from steam evacuated from the sterilization chamber.		



**Section 6 – Repair Procedures**

<b>Repair</b>	<b>Procedure #</b>	<b>Page #</b>
Chamber heating element	33	119
Chamber internal PT100 T° sensor	31	117
Chamber outlet filter	37	122
Composite door cover	2	97
Composite fascia	4	99
Composite service door	30	117
Condenser and condenser fan	23	112
Cover	1	97
CPU board	17	107
Door	3	98
Door locking encoder board	11	103
Door locking motor	10	102
Door seal	7	101
EPROM, Data (DT x.x) and program (EU x.x)	25	113
EV1-EV3 coil and solenoid	28	115
EV1-EV3 subset	26	114
EV2-EV4 subset	20	109
EV5 subset	21	110
EV5 subset filter	38	123
External chamber PT100 sensor	24	113
Fascia/cover seal	36	121
Mains filter pack	12	104
Pressure safety valves housing	19	108
Printer interface	18	107
Rear housing cover	13	104
Rear support frame (including subsets)	29	116
Steam generator	14	105
Steam generator heating element	15	106
Steam generator PT100 T° sensor	39	123
Steam generator thermal-overload	22	111
Thermal-overload	32	118
Touchscreen	5	100
Vacuum pump	8	101
Vacuum pump membrane kit	27	114
Vacuum pump silencer	34	120
Water pump	16	106
Water pump one-way valve spring	35	120
Water tank	9	102

**How to Use  
the Repair  
Procedures**

Use these procedures in combination with the removal, replacement and mounting layouts in Chapter 7 and the troubleshooting charts in Chapter 4.

The procedures in this section are presented as flow chart diagrams, which use the following symbols:

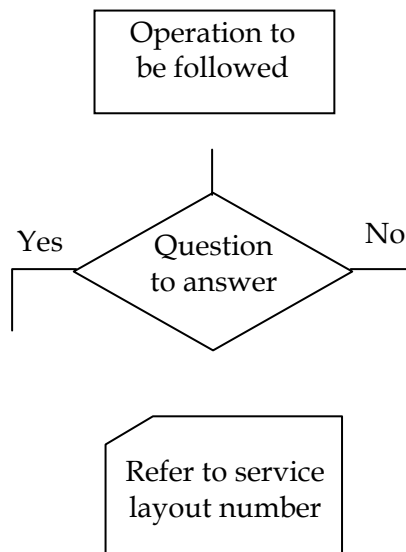

**Procedure 1 – Replace Cover**

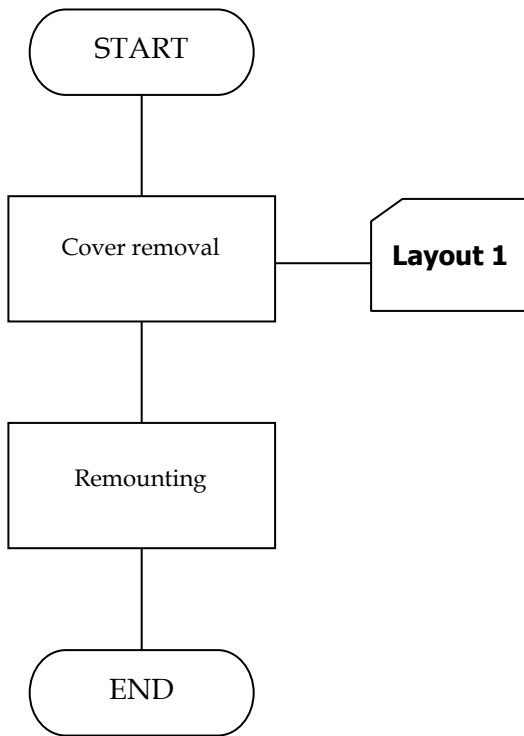

**Procedure 2 – Replace Composite Door Cover**

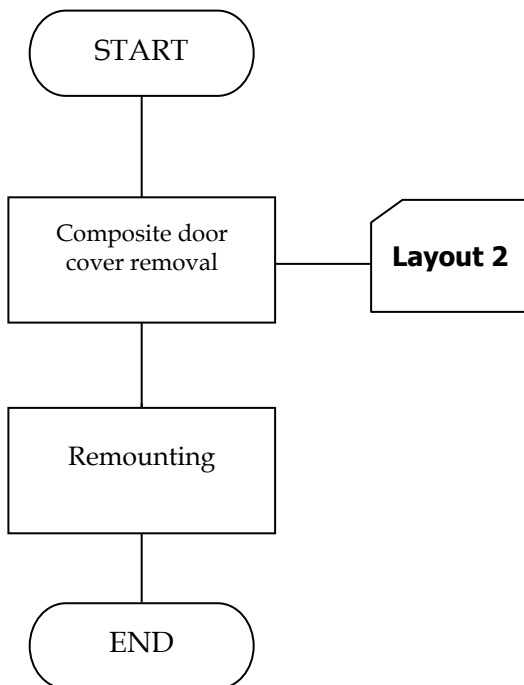

**Procedure 3 – Replace Door**

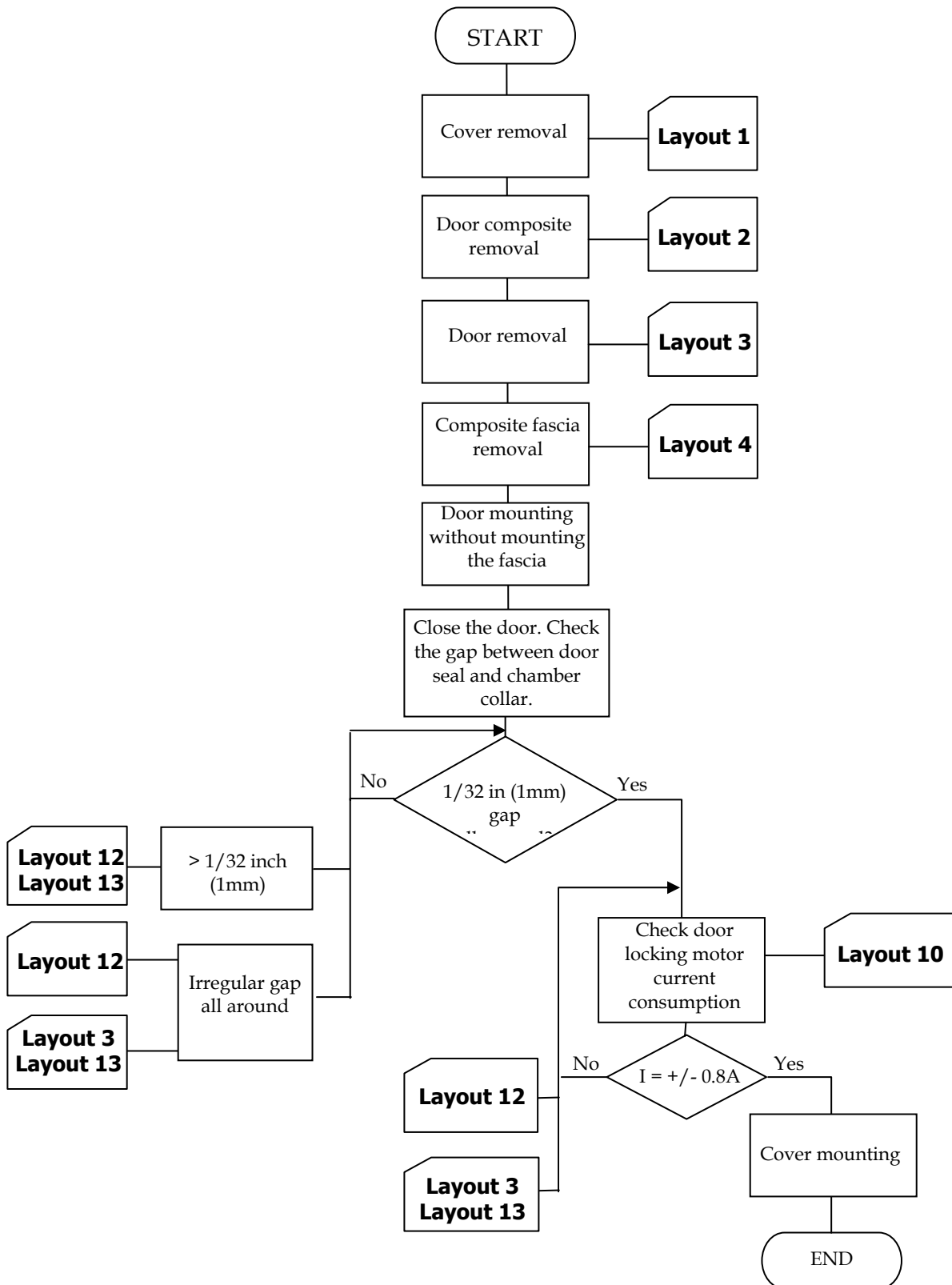



**Procedure 4 – Replace Composite Fascia**

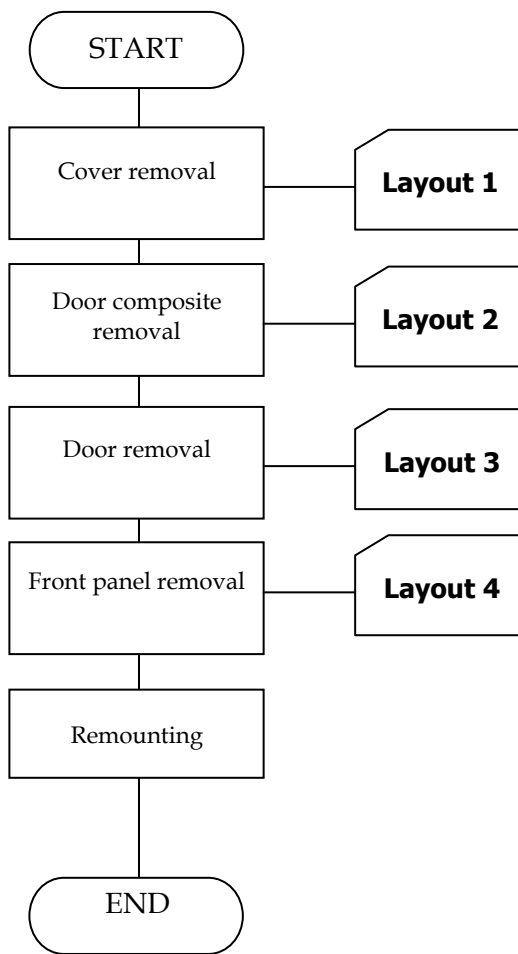

**Procedure 5 – Replace Touchscreen**

Quick Procedure

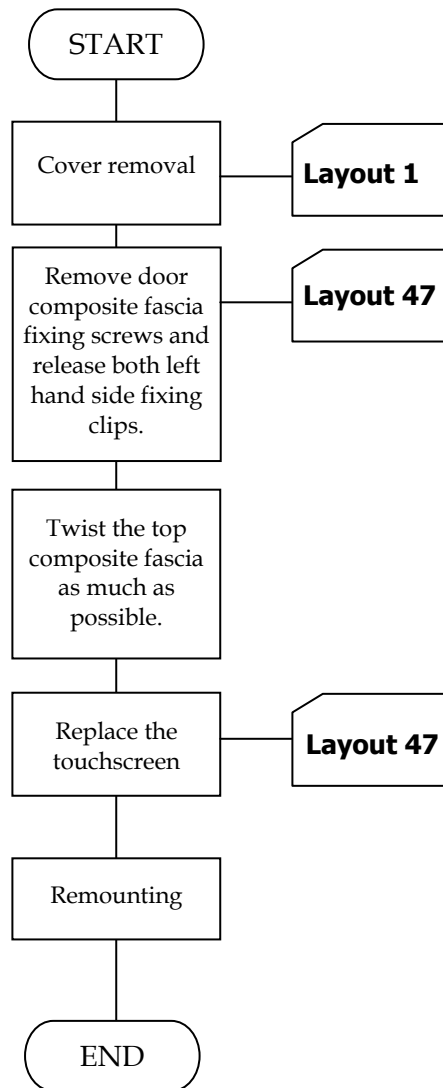

Standard Procedure

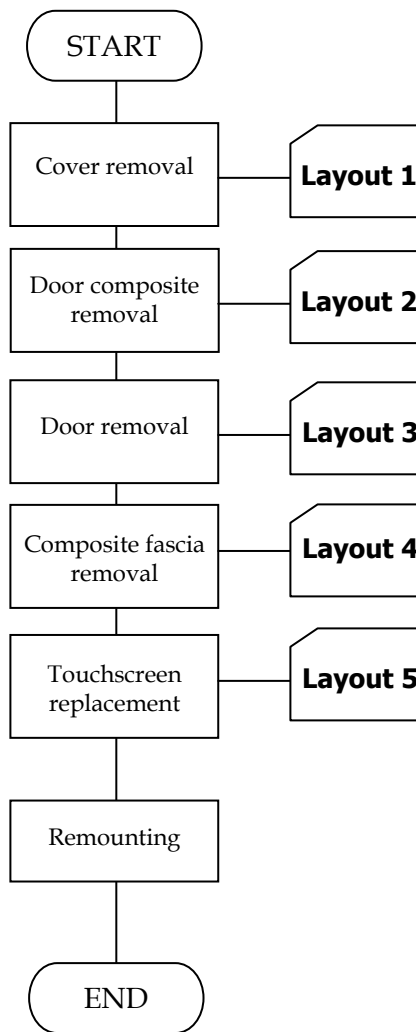

**Procedure 7 – Replace Door Seal (replace new type with new type)**

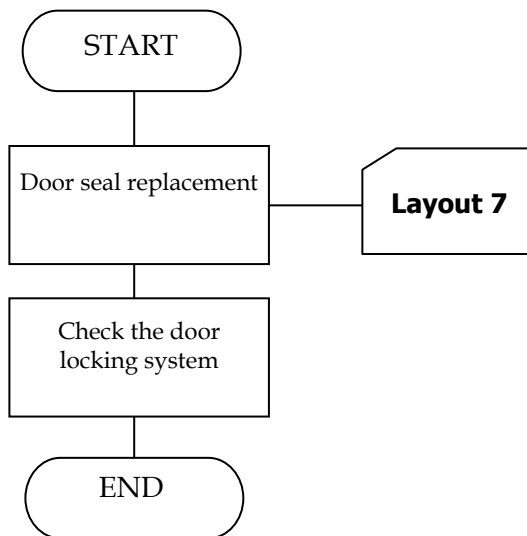

**Procedure 8 – Replace Vacuum Pump**

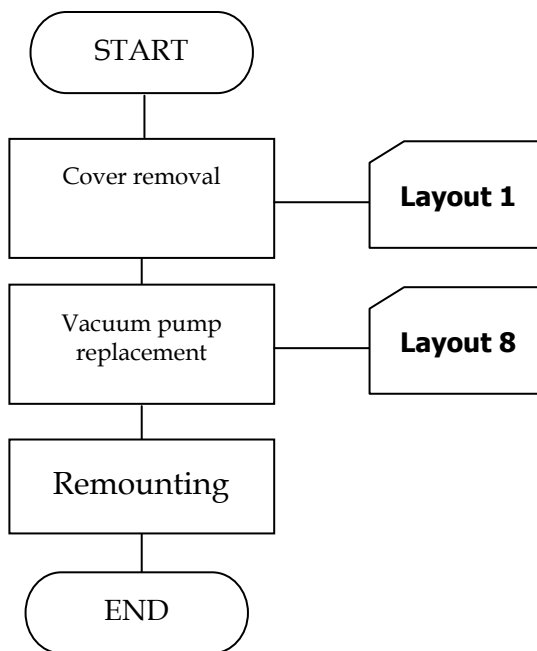

**Procedure 9 – Replace Water Tank**

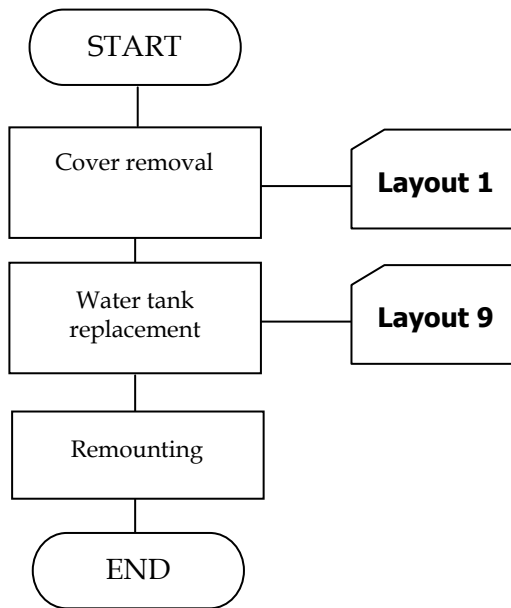

**Procedure 10 – Replace Door Locking Motor**

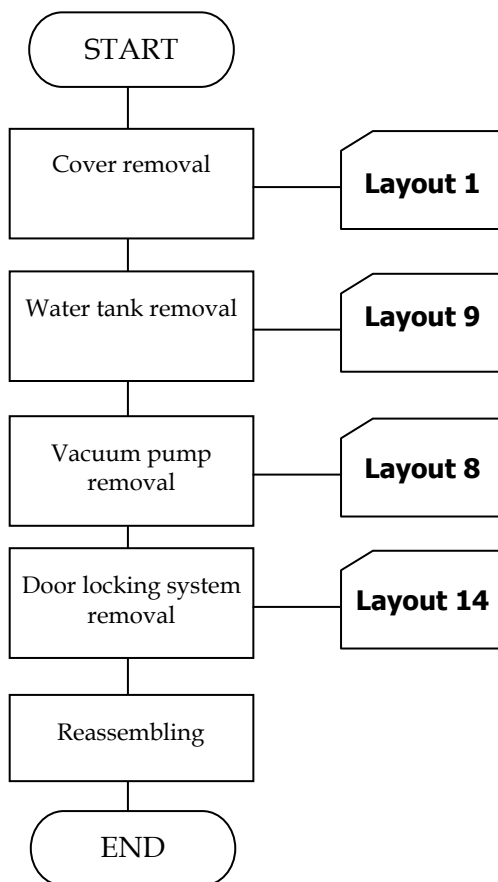

**Procedure 11 – Replace Door Locking Encoder Board**

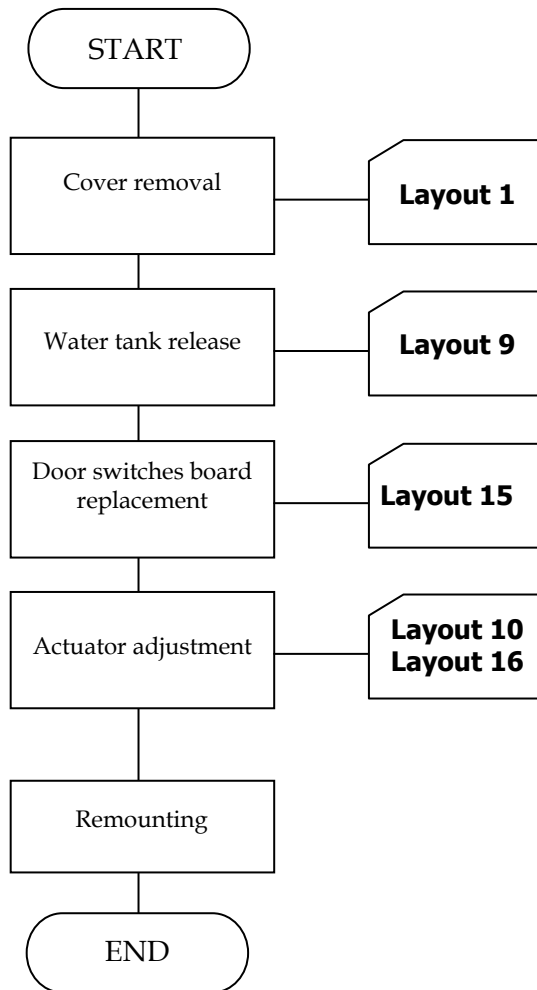

**Procedure 12 – Replace Mains Filter Pack**

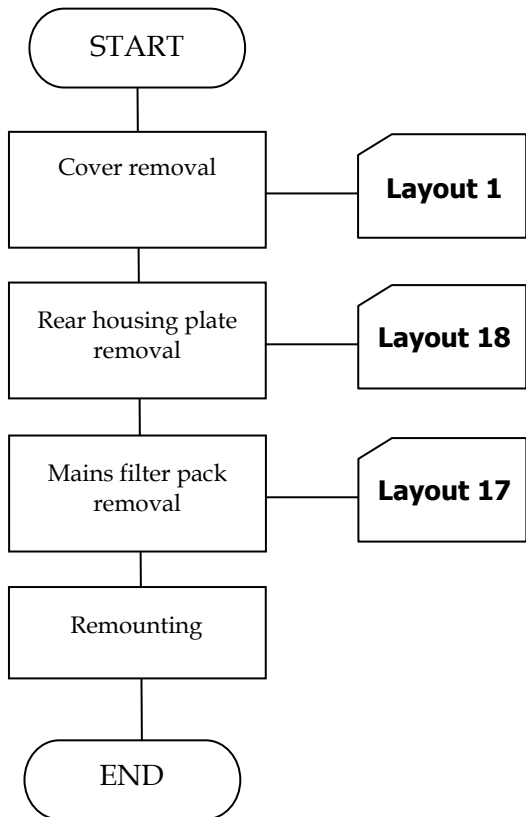

**Procedure 13 – Remove Rear Housing Plate**

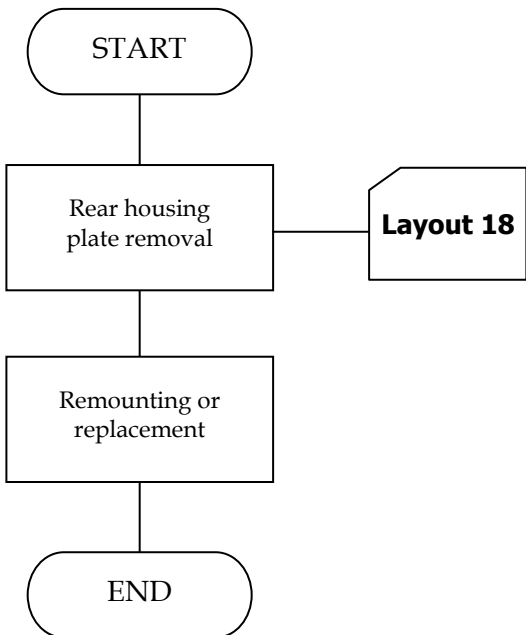

**Procedure 14 – Replace Steam Generator**

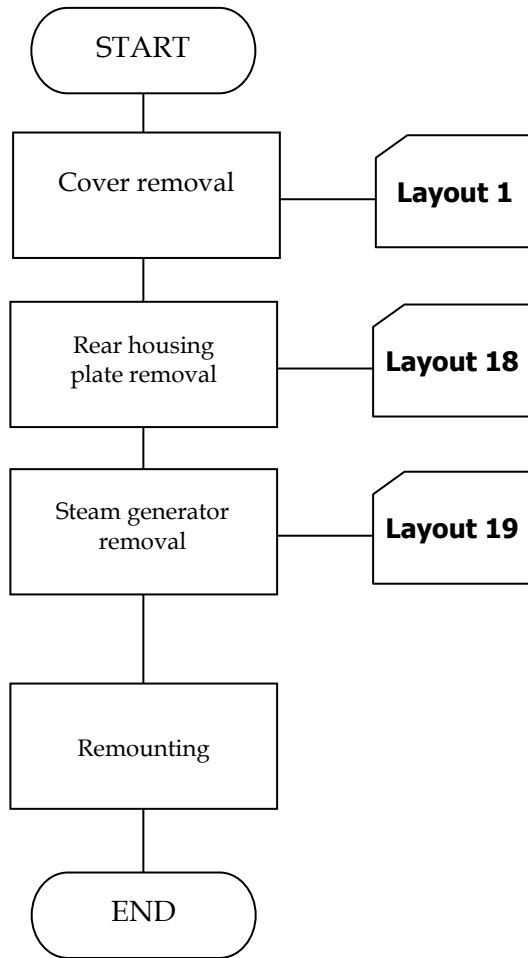

**Procedure 15 – Replace Steam Generator Heating Element**

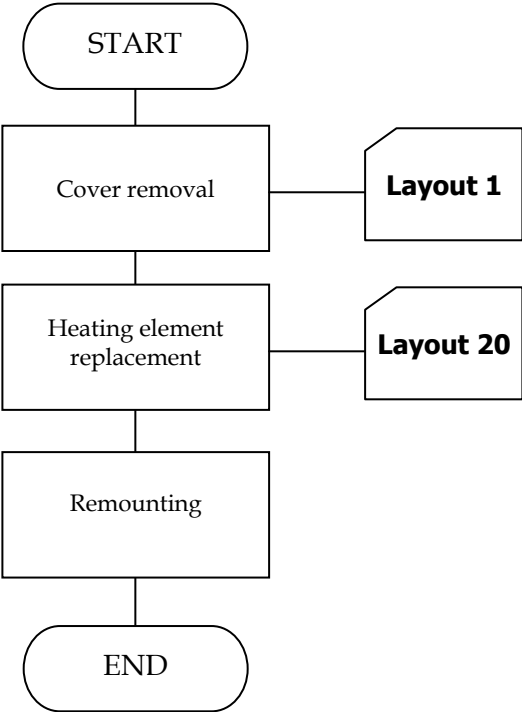

**Procedure 16 – Replace Water Pump**

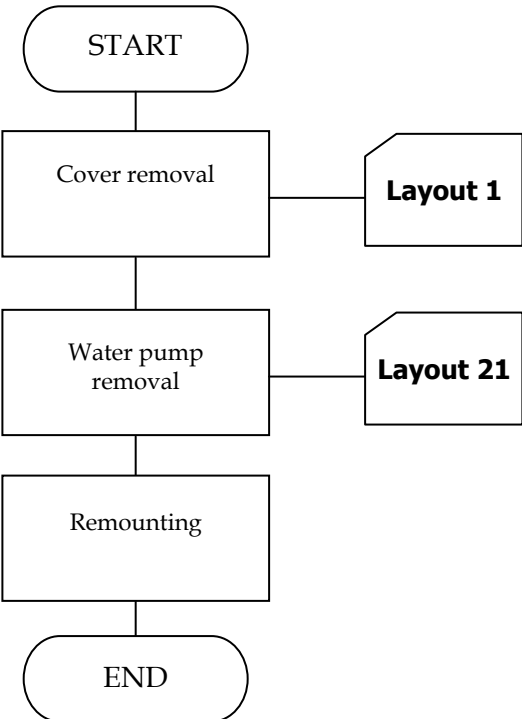



**Procedure 17 – Replace CPU Board**

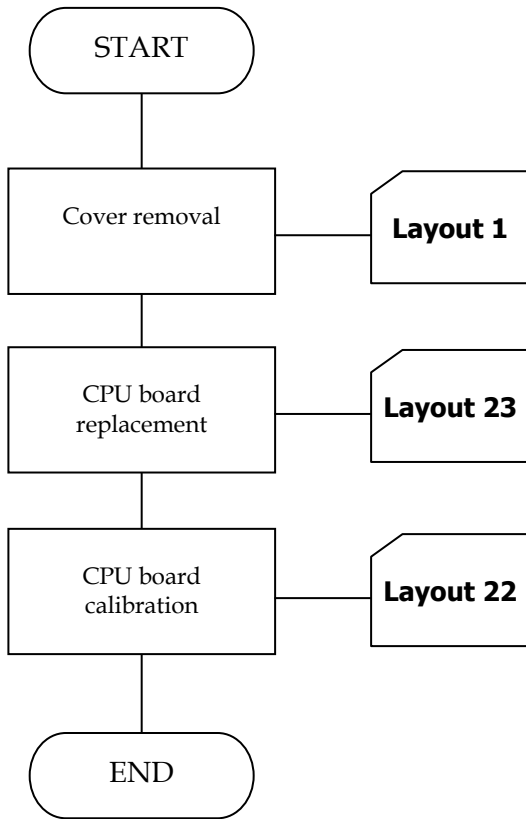

**Procedure 18 – Replace Printer Interface**

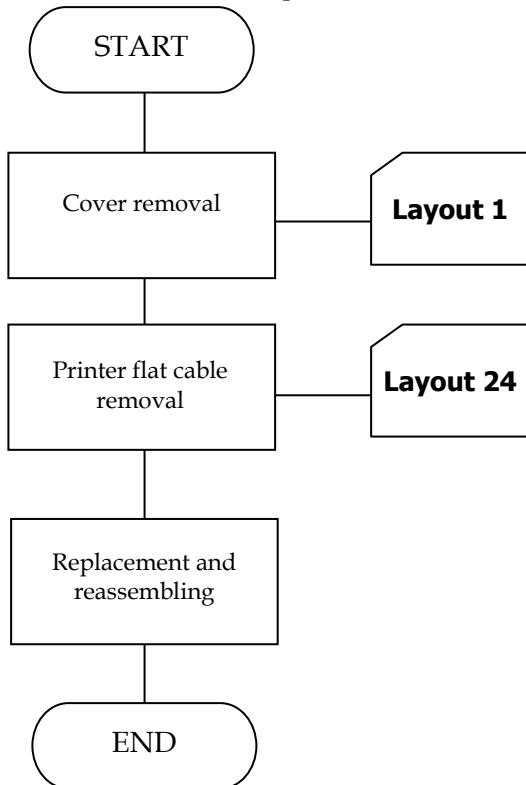

**Procedure 19 – Replace Pressure Safety Valves Housing**

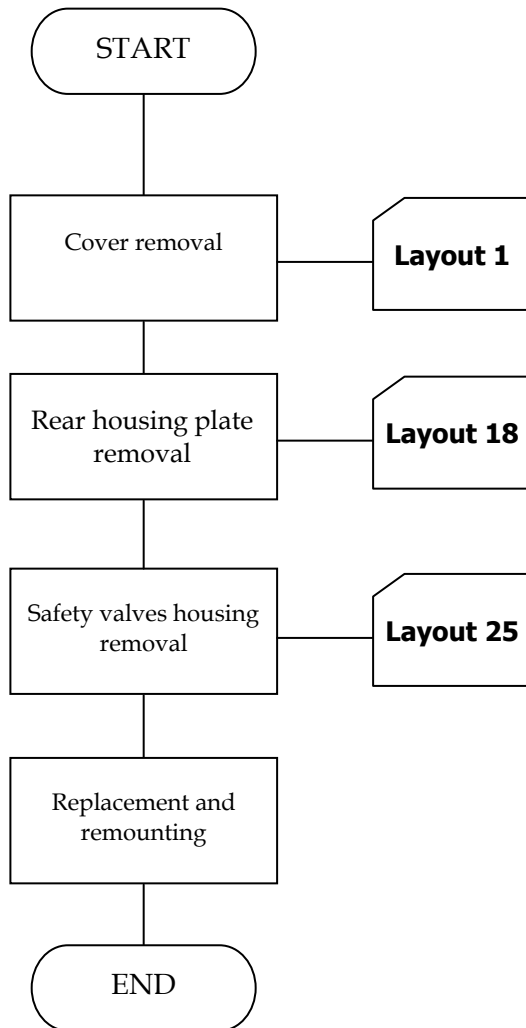

**Procedure 20 – Replace EV2-EV4 Subset**

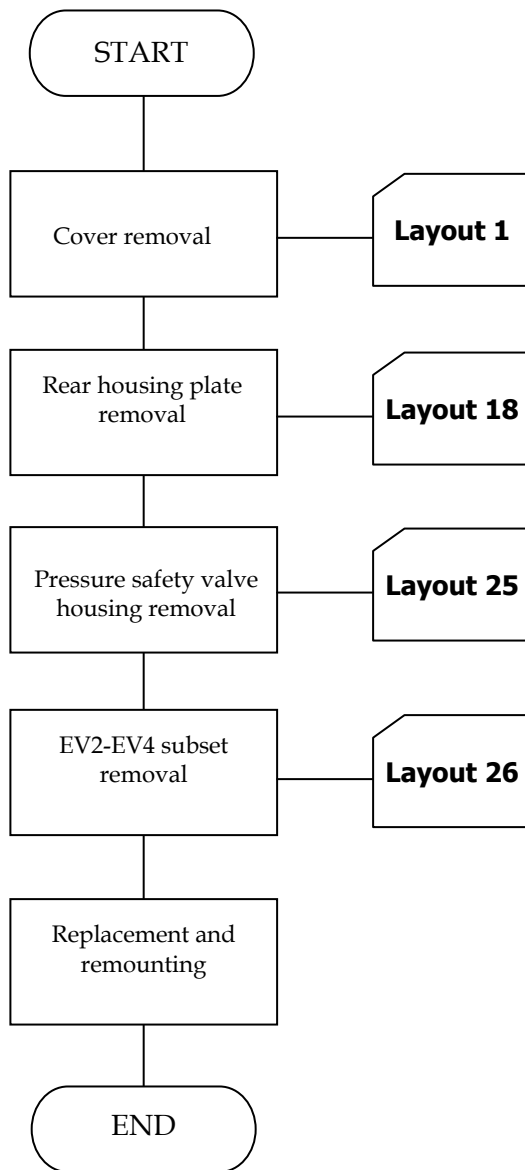

**Procedure 21 – Replace EV5 Subset**

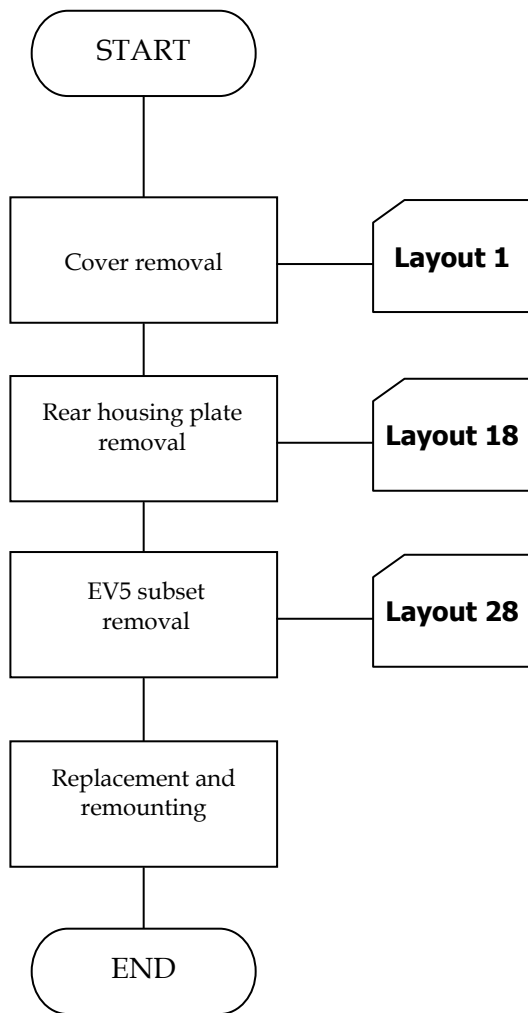

**Procedure 22 – Replace Steam Generator Thermal-Overload**

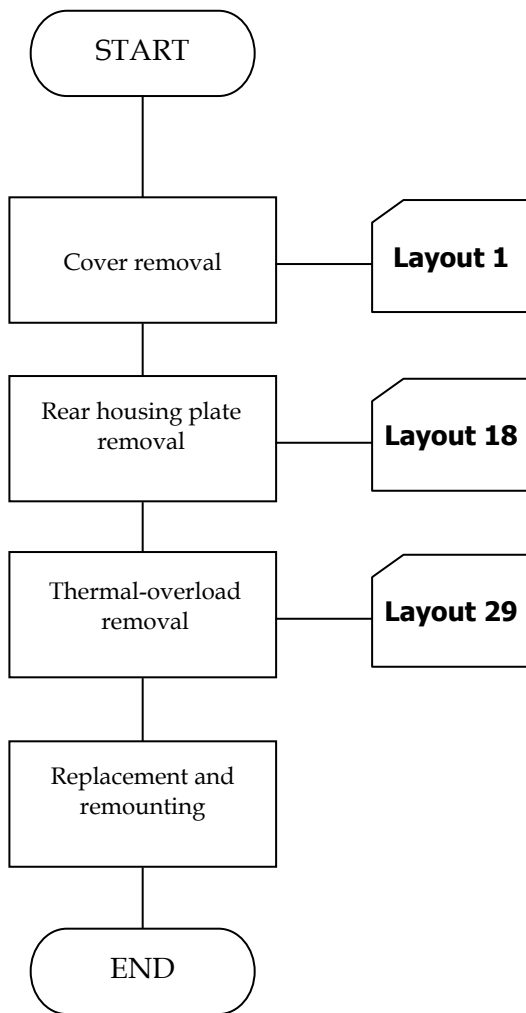

**Procedure 23 – Replace Condenser and Condenser Fan**

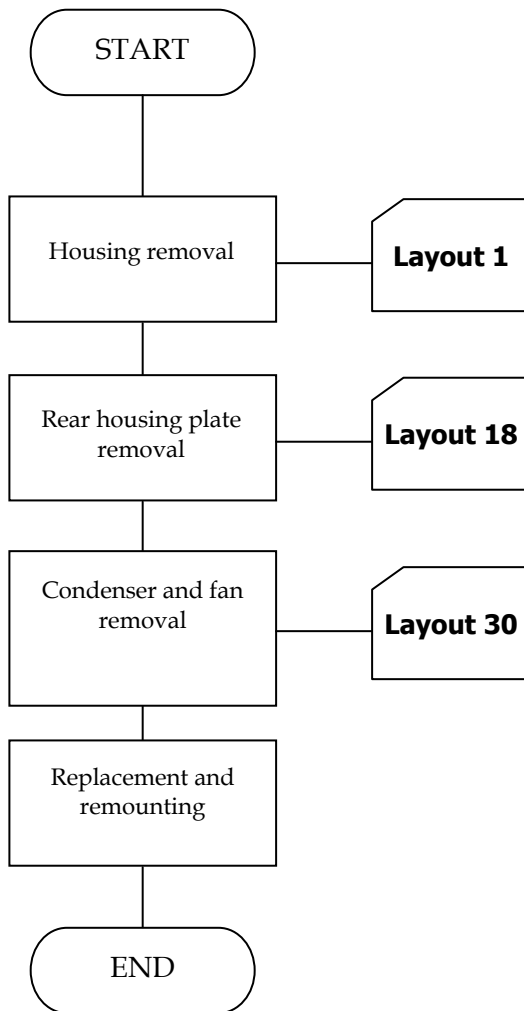

**Procedure 24 – Replace External Chamber PT100 Sensor**

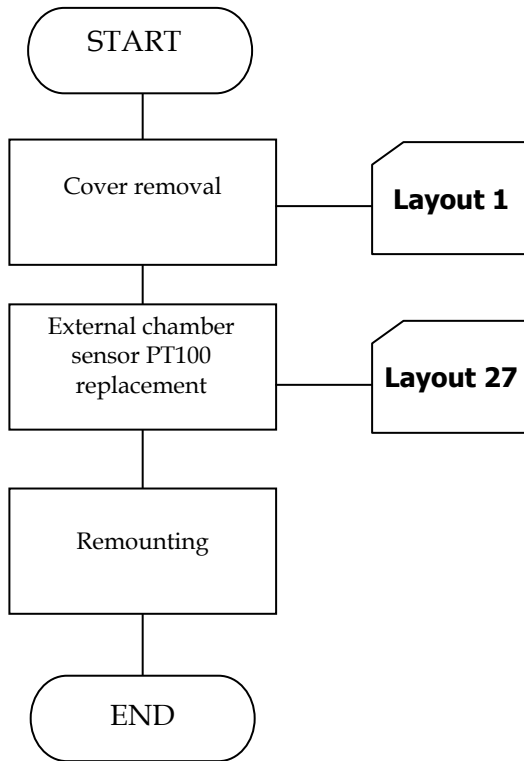

**Procedure 25 – Replace Data (DT x.x) and Program (EU x.x) EPROM**

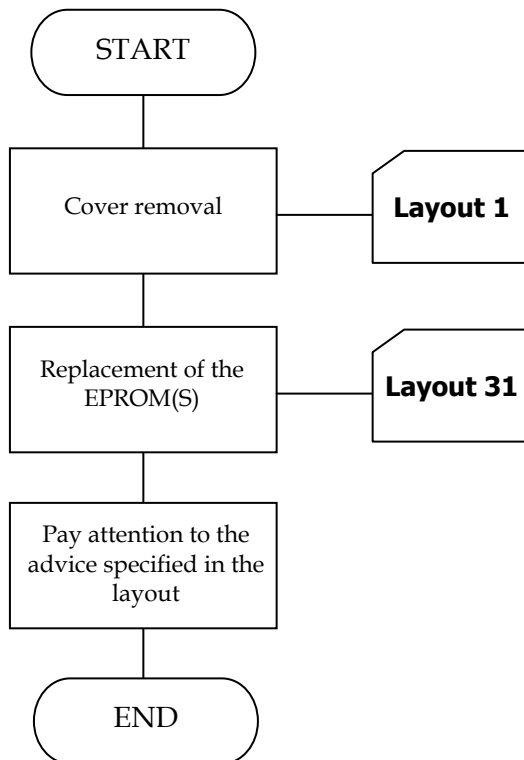

**Procedure 26 – Replace EV1-EV3 Subset**

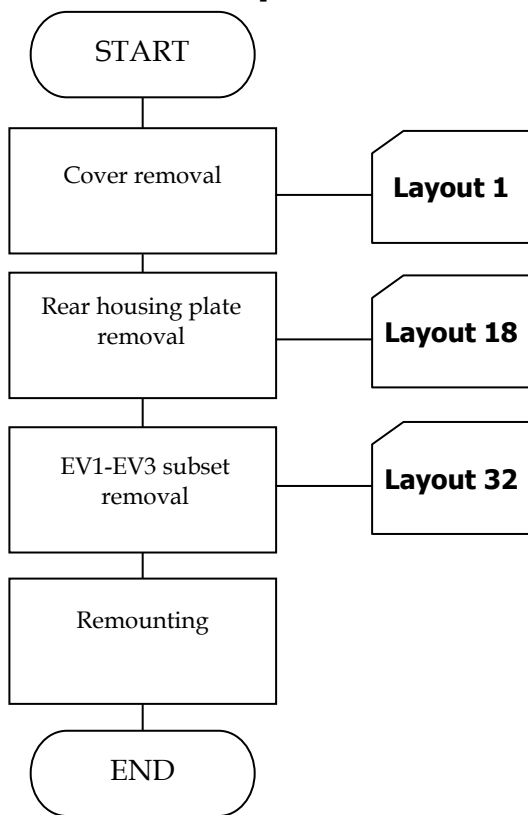

**Procedure 27 – Replace Vacuum Pump Membrane Kit**

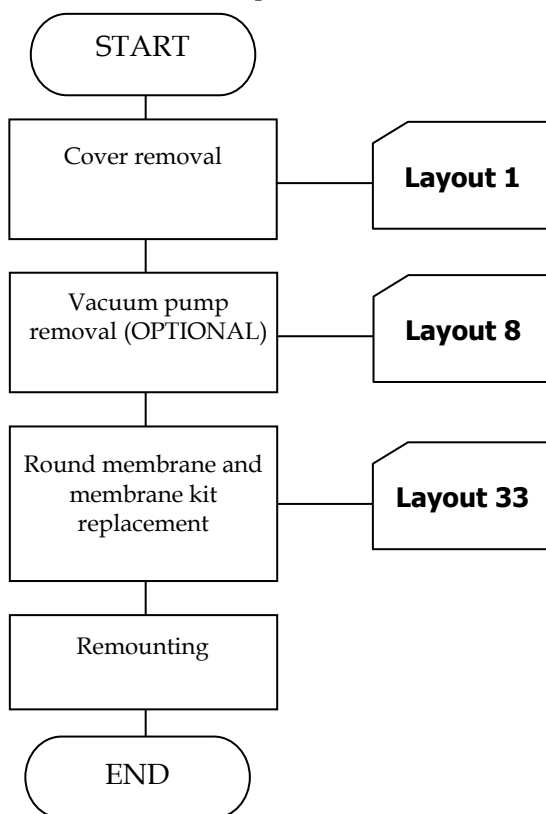



**Procedure 28 – Replace EV1-EV3 Coil and Solenoid**

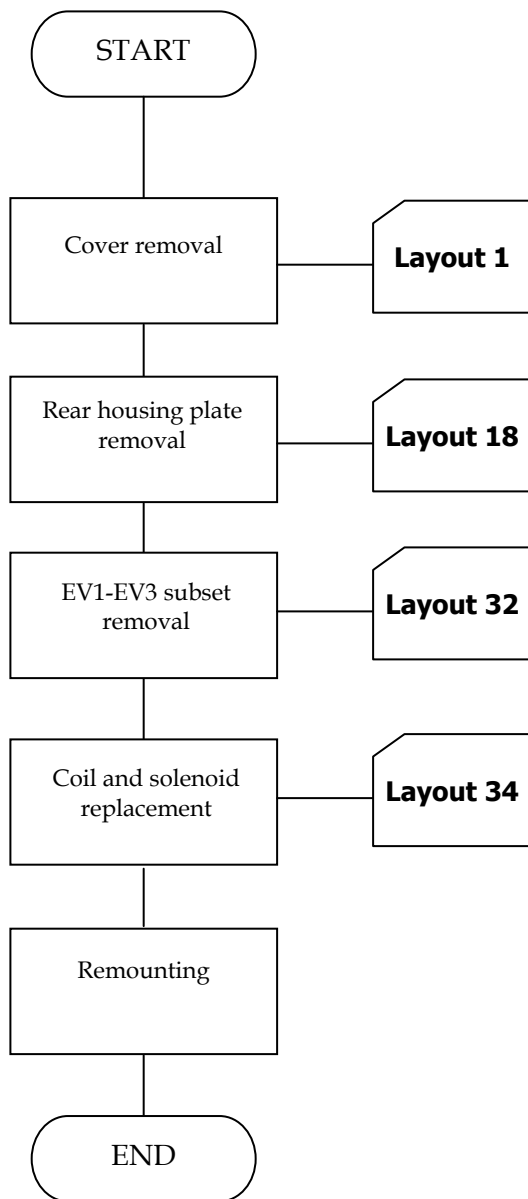

**Procedure 29 – Replace Complete Rear Support Frame  
(including subsets)**

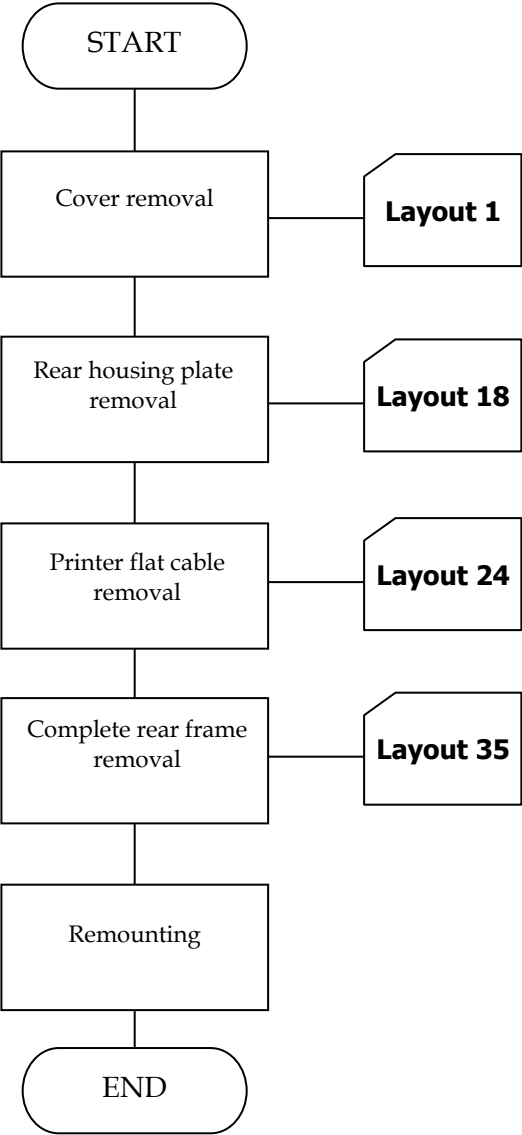

**Procedure 30 – Replace Composite Service Door**

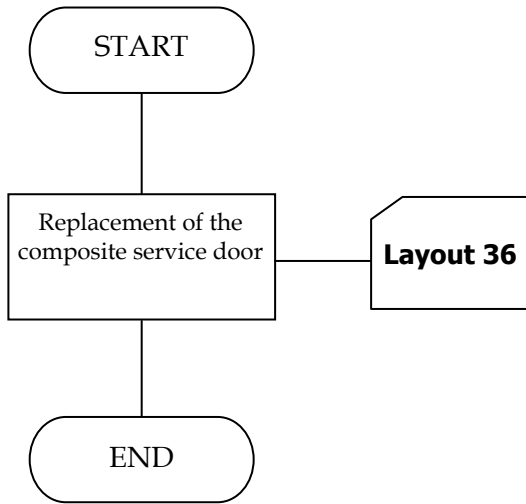

**Procedure 31 – Replace Chamber Internal PT100 T° Sensor**

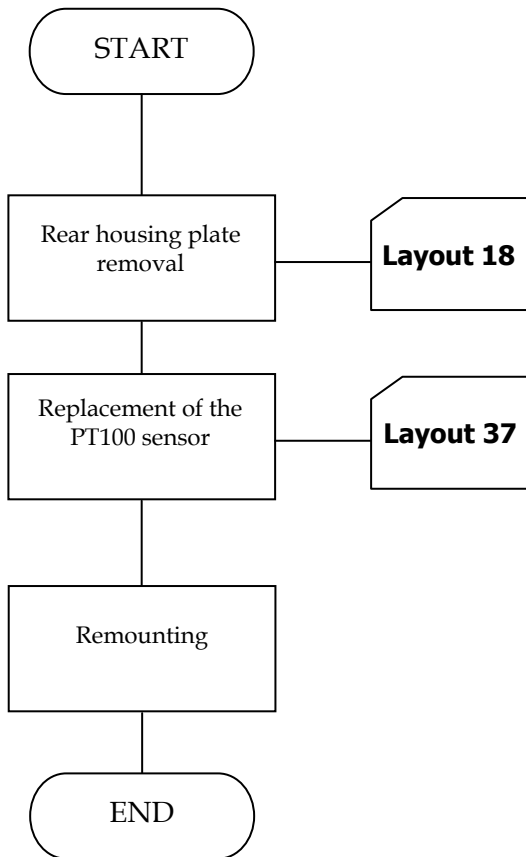

**Procedure 32 – Replace Thermal-Overload**

Procedure for previous model

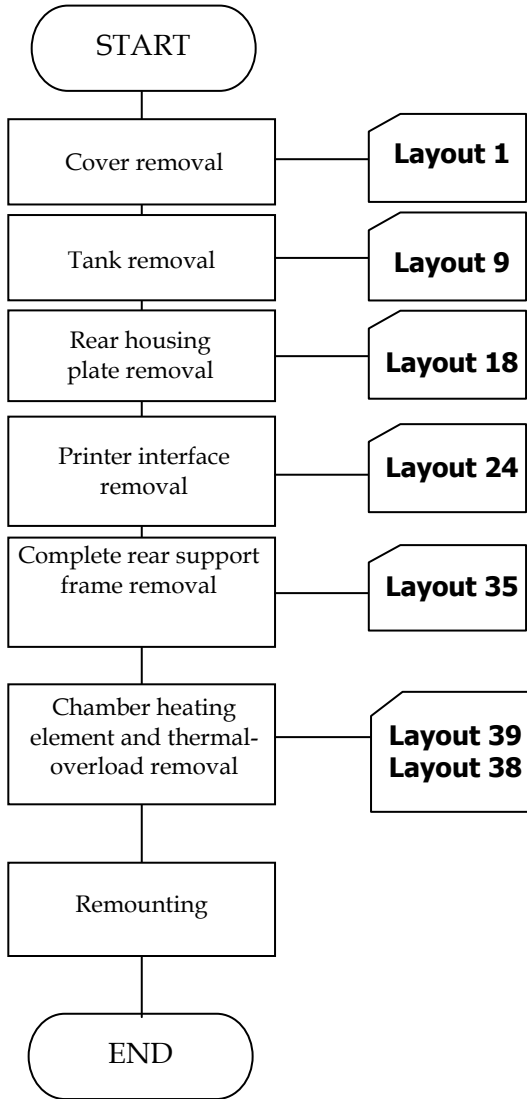

Procedure for the newest version  
(screwed onto the heating element)

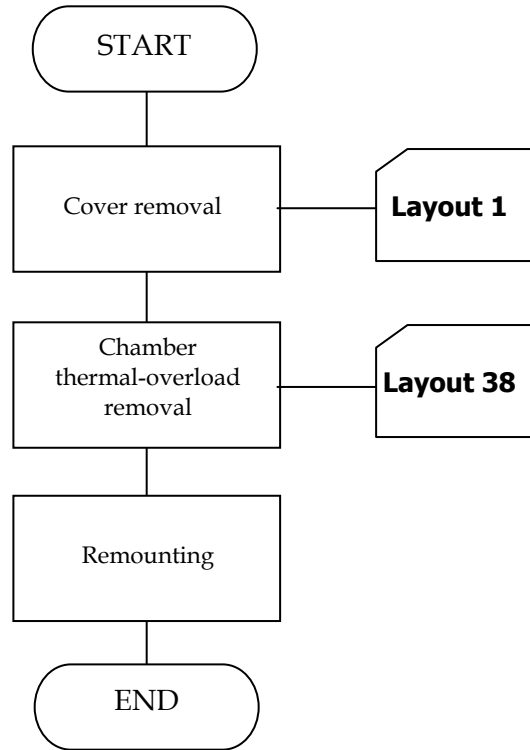

**Procedure 33 – Replace Chamber Heating Element**

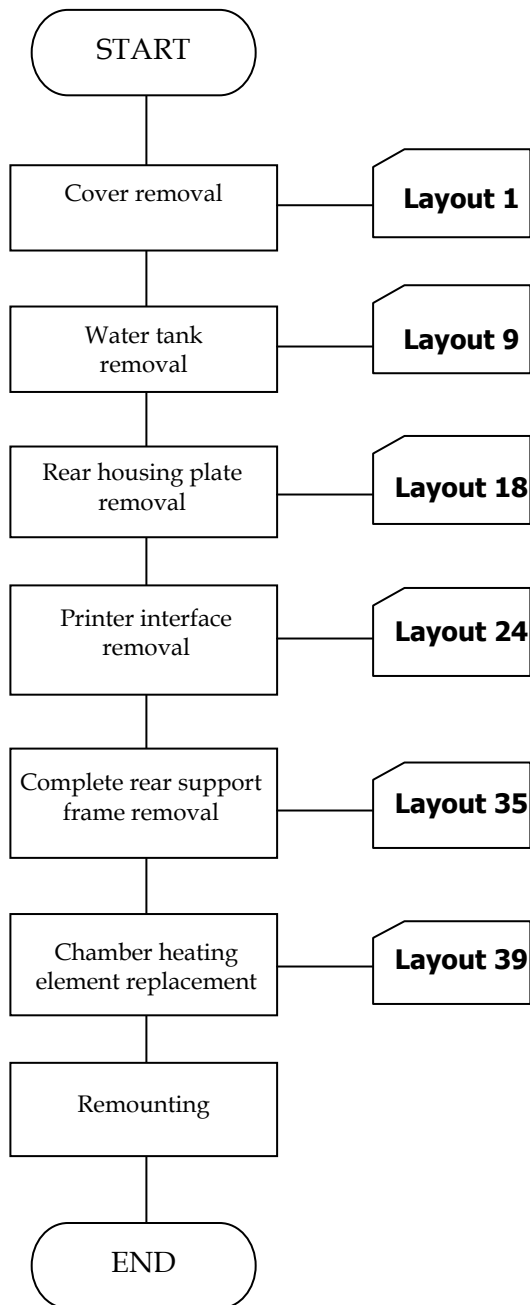

**Procedure 34 – Replace Vacuum Pump Silencer**

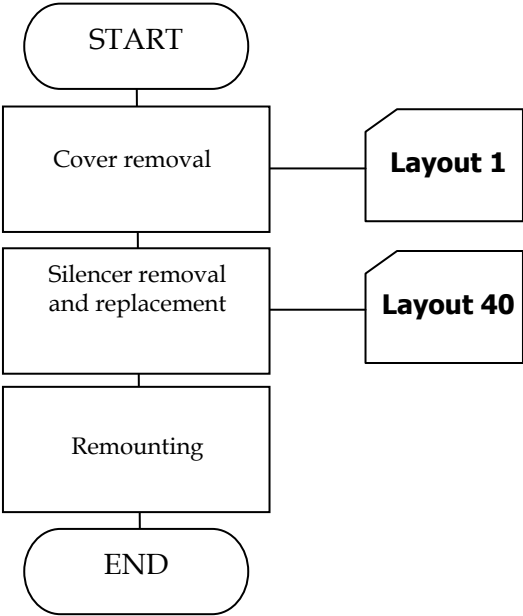

**Procedure 35 – Replace/Adjust Water Pump One-Way Valve Spring**

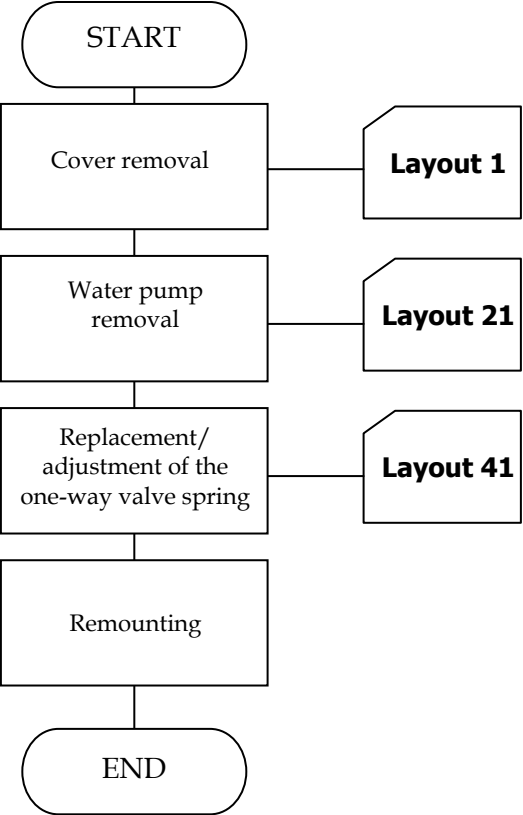

**Procedure 36 – Add/Replace Fascia/Cover Seal**

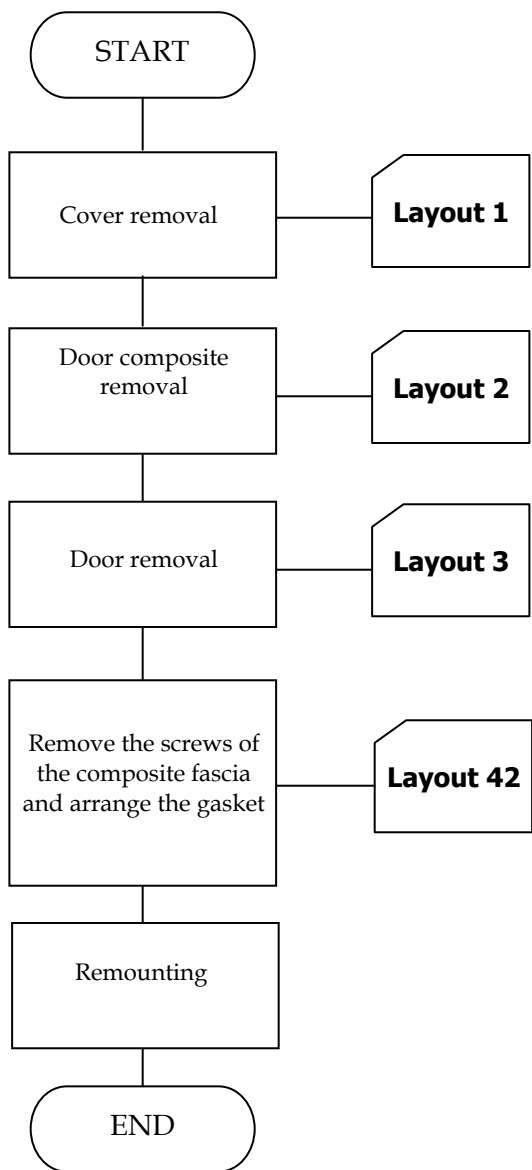

**Procedure 37 – Clean Chamber Outlet Filter**

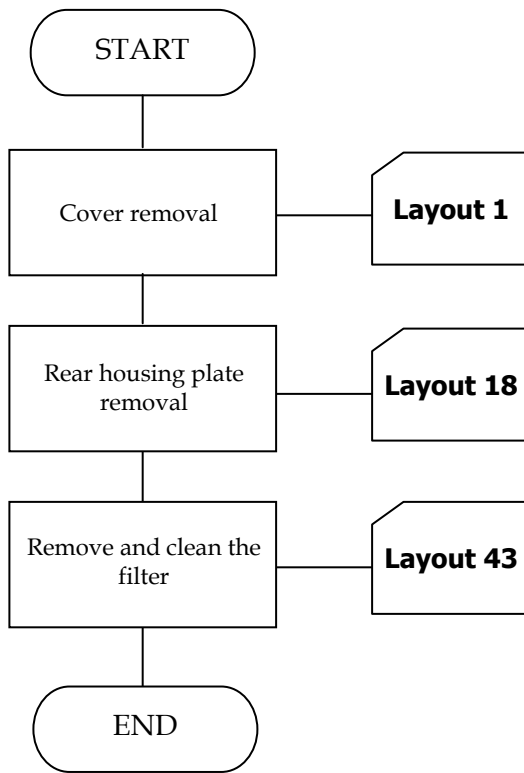



**Procedure 38 – Clean EV5 Subset Filter**

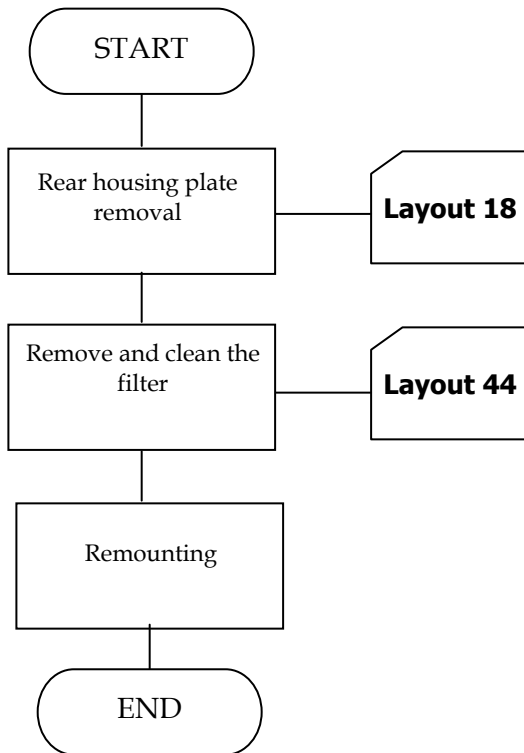

**Procedure 39 – Replace Steam Generator PT100 sensor**

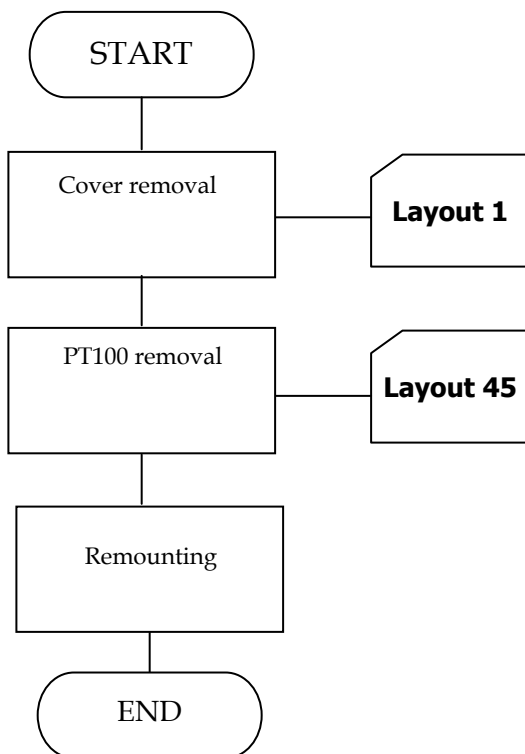



**Section 7 – Service Layouts**

<b>Part to Service</b>	<b>Layout #</b>	<b>Page #</b>
Chamber heating element	39	171
Chamber internal PT100 T° sensor	37	169
Chamber outlet filter	43	177
Chamber thermal-overload switch	38	170
Composite door cover	2	129
Composite fascia	4	131
Composite service door	36	168
Condenser and condenser fan	30	160
Cover	1	127
CPU board	23	153
CPU board, calibrate PT100 and pressure transducer	22	150
Door	3	130
Door, adjust locking pin side	12	138
Door, adjust hinge mount	13	140
Door, adjust locking system switches	16	144
Door locking switch board	15	143
Door locking system	14	142
Door locking motor	10	137
Door seal	7	133
EPROM	31	162
EV1-EV3 coil and solenoid	34	166
EV1-EV3 subset	32	163
EV2-EV4 subset	26	158
EV5 subset	28	158
EV5 subset filter	44	178
External chamber PT100 T° sensor	27	157
Fascia/cover seal	42	176
Mains filter pack	17	145
Pressure safety valves housing	25	155
Printer interface	24	154
Rear housing cover	18	146
Rear support frame	35	167
Steam generator	19	147
Steam generator heating element	20	148
Steam generator PT100 T° sensor	45	179
Steam generator thermal-overload	29	159
Test connection for process validation (access)	46	180
Touchscreen	5, 47	132, 182
Vacuum pump	8	134
Vacuum pump membrane kit	33	164
Vacuum pump silencer	40	173
Water pump	21	149
Water pump one-way valve spring	41	175
Water tank	9	135

**How to Use  
the Repair  
Layouts**

The service layouts are numbered individually to facilitate access and use. The layouts are linked to the service procedures in Section 6. The layouts include removal, replacement, mounting and adjustment descriptions.

**Layout 1 – Remove/Replace Cover**

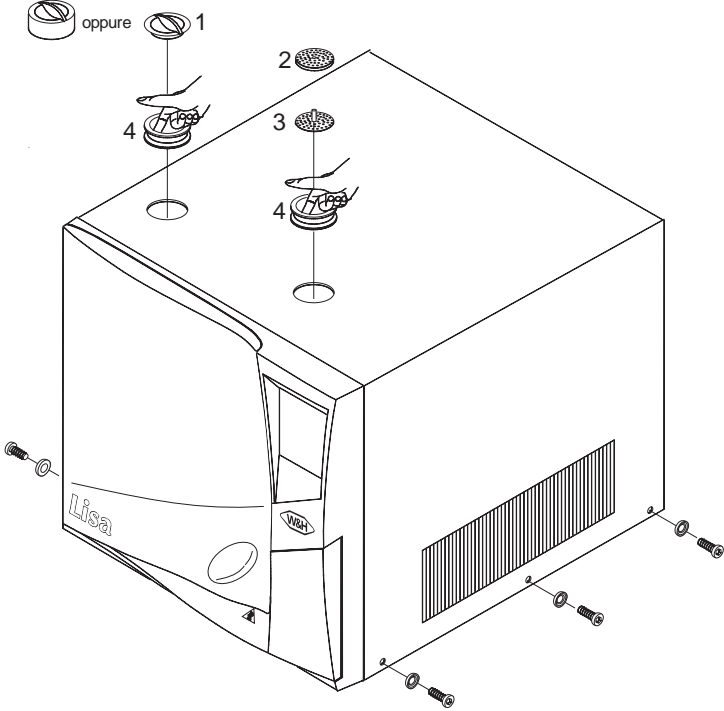
#	Procedures	Tools
<b>1</b>	<p>Remove both seal caps (1) and (2), tank silencer (3) and both grommets (4) with a finger.</p> <p>Remove the 6 screws and washers securing cover.</p>  <p>The diagram shows a top-down view of the sterilizer's cover. Callout 1 points to a seal cap on the left side. Callout 2 points to a seal cap on the right side. Callout 3 points to a tank silencer in the center. Callout 4 points to grommets on both the left and right sides. The sterilizer has 'Lisa' and 'VWR' logos on the front panel. Six screws and washers are shown being removed from the bottom edge of the cover.</p>	3mm Allen key or Phillips screwdriver

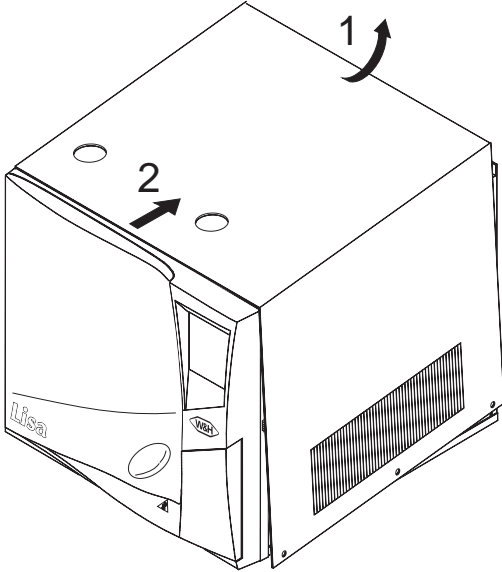
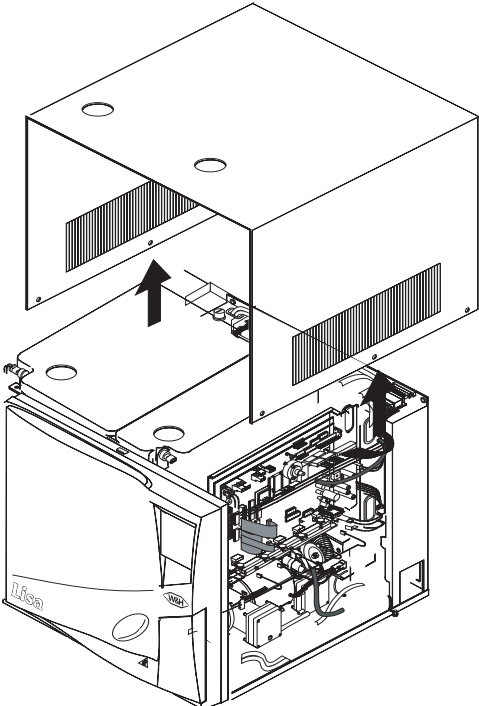
#	Procedures	Tools
2	<p>Lift the rear of the cover (1)/ Gently slide the cover back (2).</p> 	
3	<p>Lift the cover by spreading both sides. Keep the 3 EMC cover contacts clipped on the frame.</p> 	
4	<p>To remount, follow this procedure in reverse order.</p>	

**Layout 2 – Remove/Replace Composite Door Cover**

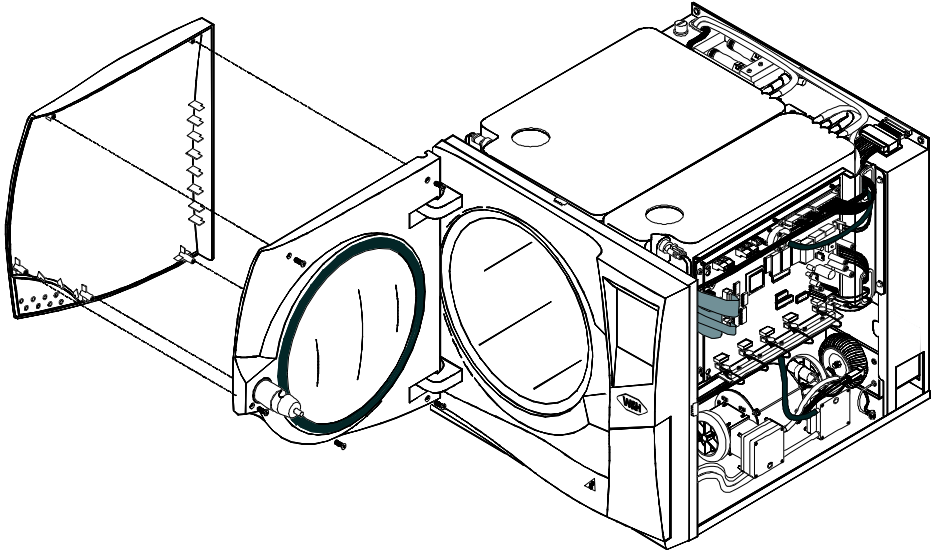
#	Procedures	Tools
<p><b>1</b></p>	<p>Open the door to access the composite cover fixing screws. Remove the five screws.</p> 	<p>DIN 1 x100 (Ø 4.5) Phillips screwdriver</p>
<p><b>2</b></p>	<p>To mount the door cover: fix the composite cover with the five screws.</p>	<p>DIN 1 x100 (Ø 4.5) Phillips screwdriver</p>

**Layout 3 – Remove/Replace Door**

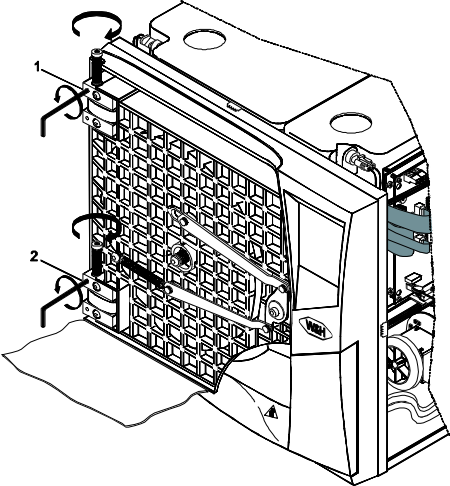
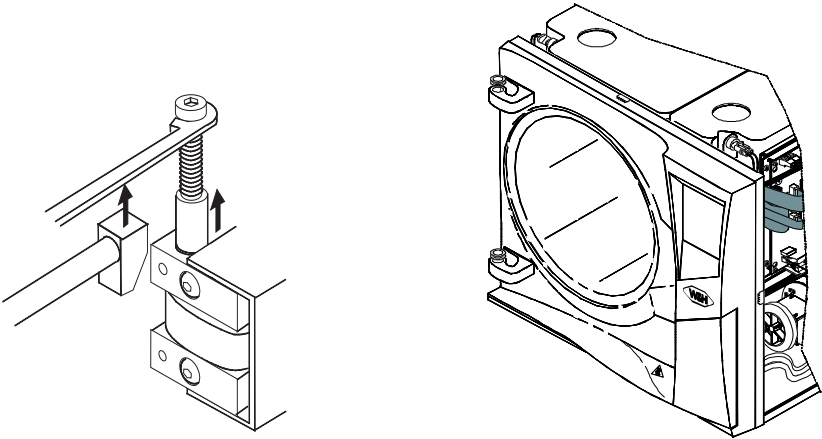
#	Procedures	Tools
<p><b>1</b></p>	<p>Remove the composite door cover (see Layout 2).                      Remove both door hinge fixing screws (1 and 2).                      Lightly screw two M5 screws in the hinges.                      Insert paper between the door and the composite fascia to avoid scratches.</p> 	<p>2mm Allen key  M5 x 40mm screws</p>
<p><b>2</b></p>	<p>Use pliers or a flat key and a hammer to extract both hinges.                      Do not to lose the spacer washers (3+3 or 2+2) positioned on the upper side of both door hinge mounts</p> 	<p>Pliers or a flat key  Hammer</p>
<p><b>3</b></p>	<p>To mount the door: follow the removal procedure in reverse order.</p>	

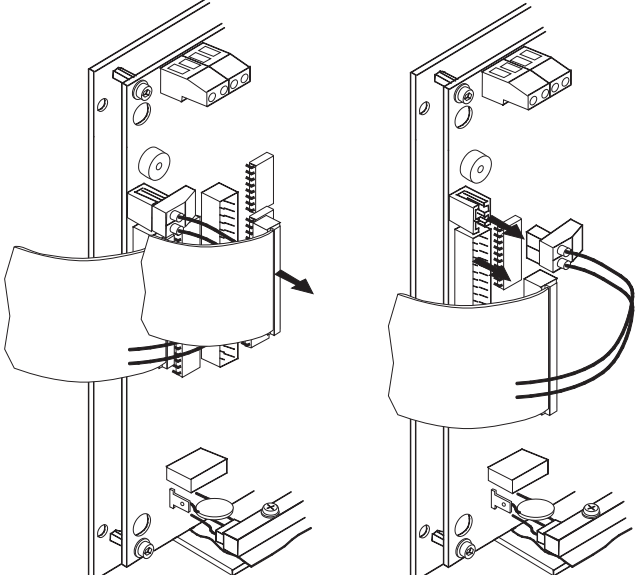
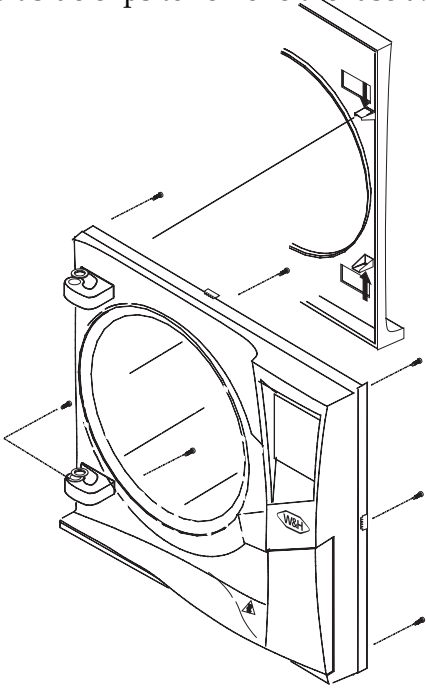

**Layout 4 – Remove/Replace Composite Fascia**

#	Procedures	Tools
<p><b>1</b></p>	<p>Remove printer and both touchscreen connectors from CPU board.</p> 	
<p><b>2</b></p>	<p>Remove the 6 screws securing the composite fascia. Release both left side clips to remove the fascia.</p> 	<p>DIN 1 (Ø4,5) Phillips screwdriver or 10x100 Torx screwdriver</p>
<p><b>3</b></p>	<p>To mount the fascia: follow the removal procedure in reverse order.</p>	

**Layout 5 – Remove/Replace Touchscreen**

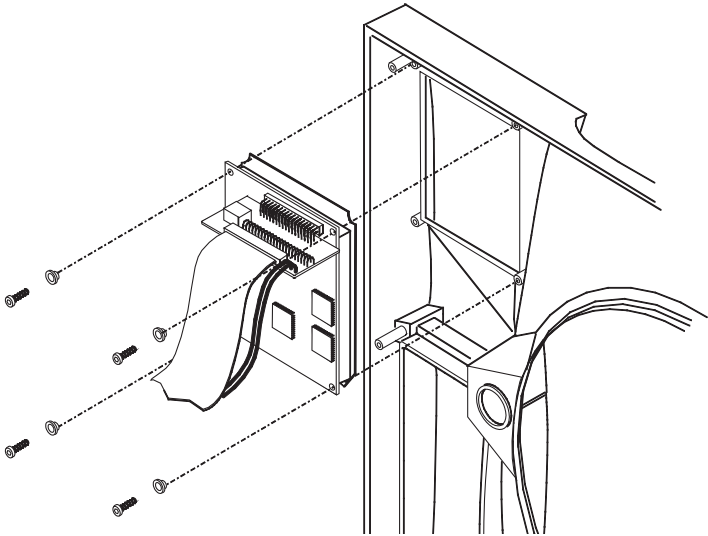
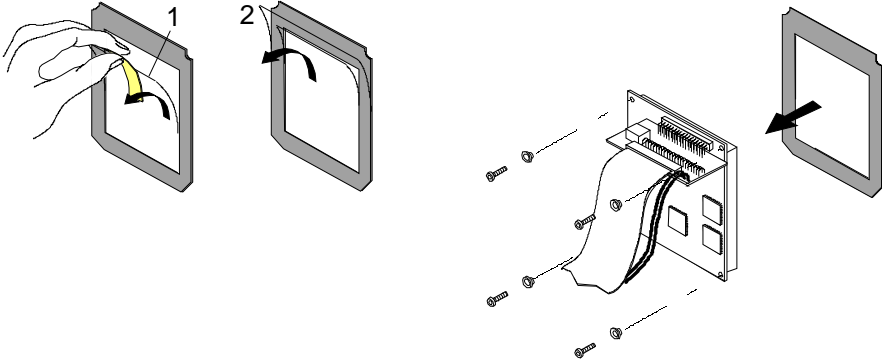
#	Procedures	Tools
<p><b>1</b></p>	<p>Remove the four screws and corresponding white insulating washers. The touchscreen board mounts ESD sensitive IC's; before handling the board eliminate possible electrostatic charges by touching an earth-connected surface.</p> 	<p>DIN 1 (Ø4.5) Phillips screwdriver or 10x100 Torx screwdriver</p>
<p><b>2</b></p>	<p>Mount the new touchscreen protection membranes as follows:</p> <ol style="list-style-type: none"> <li>1. Remove the old protection membrane(s).</li> <li>2. Use adhesive tape to remove the scratch protection (1) from the external touchscreen membrane.</li> <li>3. Remove the adhesive protection film (2). Place and fix the membrane on the touchscreen as shown.</li> </ol> <p>Mount the touchscreen on the composite fascia using the 4 screws and corresponding white insulating washers.</p> 	<p>DIN 1 (Ø4.5) Phillips screwdriver or 10x100 Torx screwdriver</p>

**Layout 7 – Replace Door Seal**

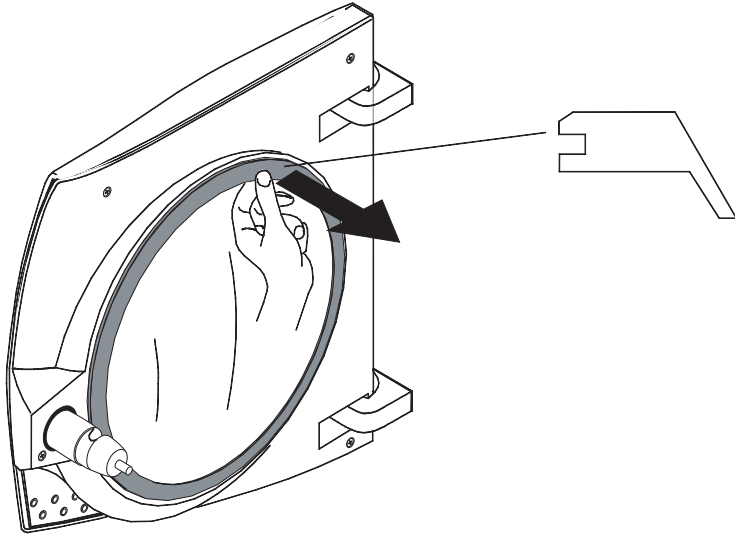
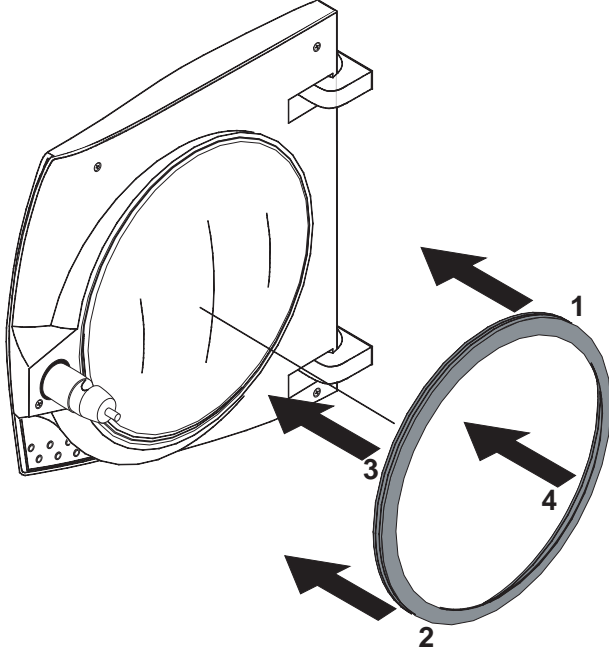
#	Procedures	Tools
<p><b>1</b></p>	<p>Open door and remove by hand the door seal.</p> 	
<p><b>2</b></p>	<p>Moisten new door seal with soapy water.                      Insert seal in its housing at point <b>1</b>; push it with a finger.                      Repeat at points <b>2, 3</b> and <b>4</b> as shown.                      Insert the door seal completely all around the porthole.</p> 	

**Layout 8 – Remove/Replace Vacuum Pump**

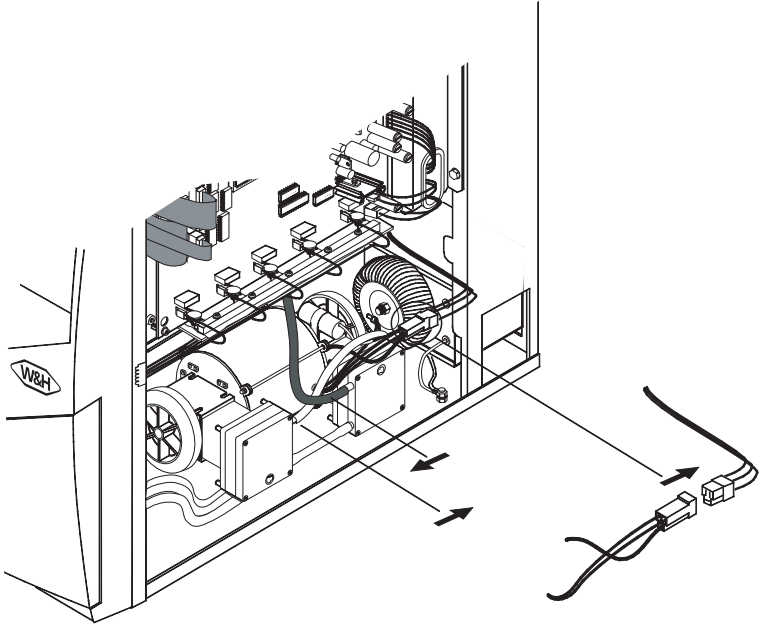
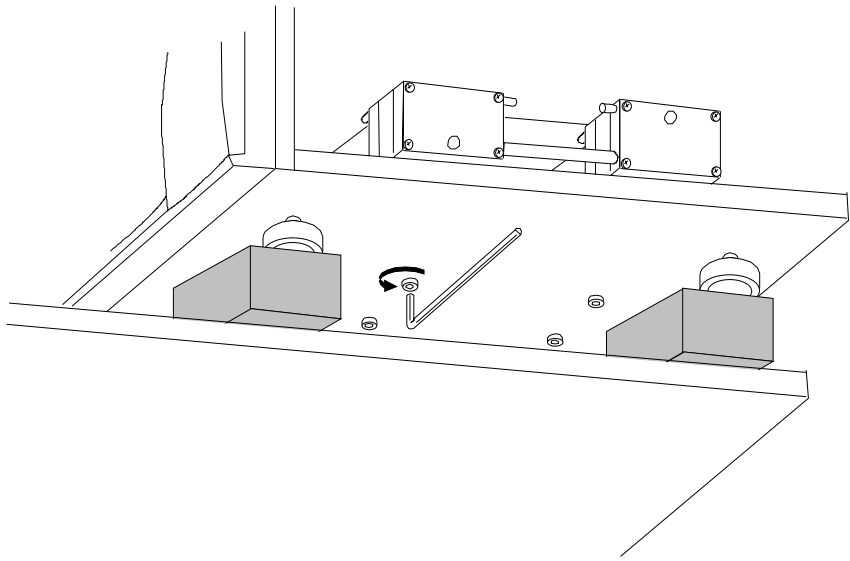
#	Procedures	Tools
1	<p>Disconnect both inlet and outlet tubes and electrical connector.</p> 	
2	<p>Lift sterilizer to access screws. Remove the four screws and washers.</p> 	3mm Allen key
3	<p>To mount the vacuum pump: follow the removal procedure in reverse order.</p>	3mm Allen key

**Layout 9 – Replace Water Tank**

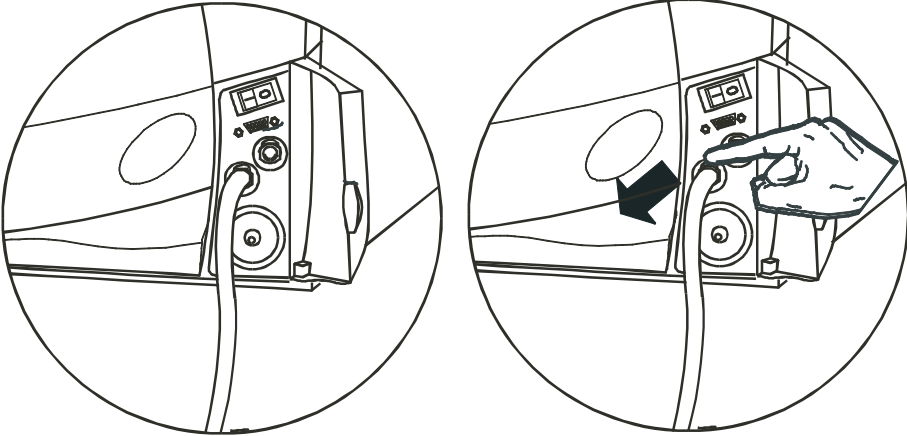
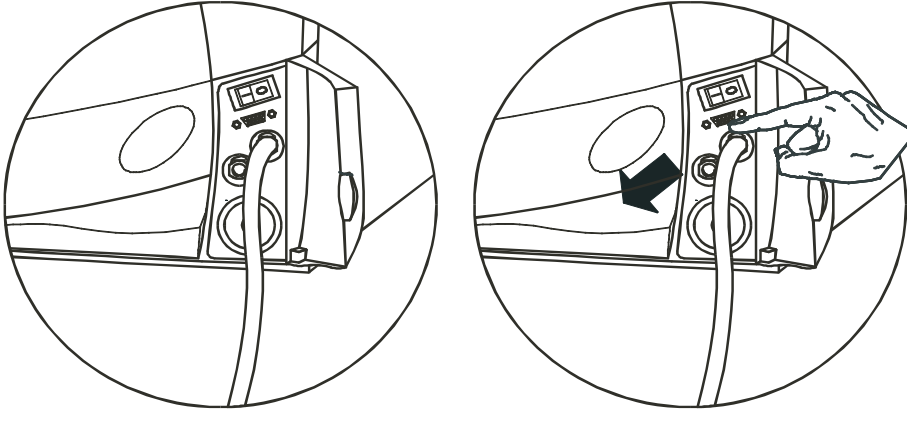
#	Procedures	Tools
<p><b>1</b></p>	<p>Connect draining tube to left water tank drain connection and drain tank completely. Disconnect the drain tube by pressing connection release push button.</p> 	<p>Drain tube provided</p>
<p><b>2</b></p>	<p>Connect draining tube to right used water tank drain connection and drain tank completely. Disconnect the drain tube by pressing connection release push button</p> 	<p>Drain tube provided</p>
<p><b>3</b></p>	<p>Disconnect all tubing from the rear side of the tank. Disconnect and</p>	<p>5.5 spanner</p>

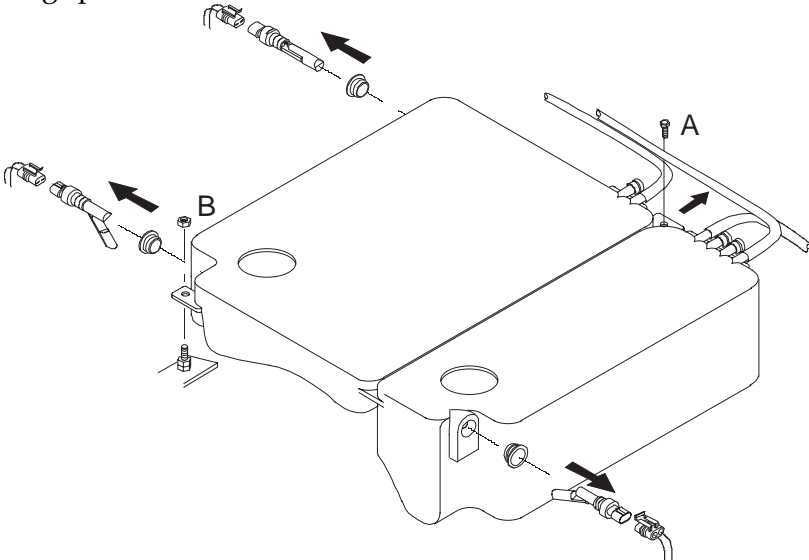
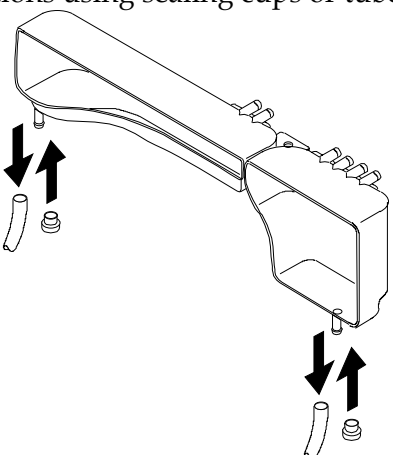
#	Procedures	Tools
	<p>remove water level sensors and seals.                      Note the orientation of the water probes for proper installation during remounting.                      Remove rear bolt (A) using 5.5mm spanner and nut (B) using 8mm ring spanner.</p> 	<p>8mm ring spanner</p>
<p><b>4</b></p>	<p>Place paper towels over the elements under the tank to avoid short-circuit by water.                      Lift tank and remove both drain tubes from underneath.                      Seal connections using sealing cups or tubes as shown.</p> 	<p>Paper towels                      Sealing cups</p>
<p><b>5</b></p>	<p>To mount the new tank: follow the removal procedure in reverse order.</p>	

**Layout 10 – Control Door Locking Motor Consumption**

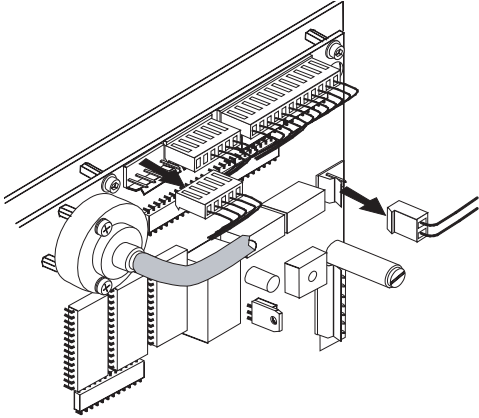
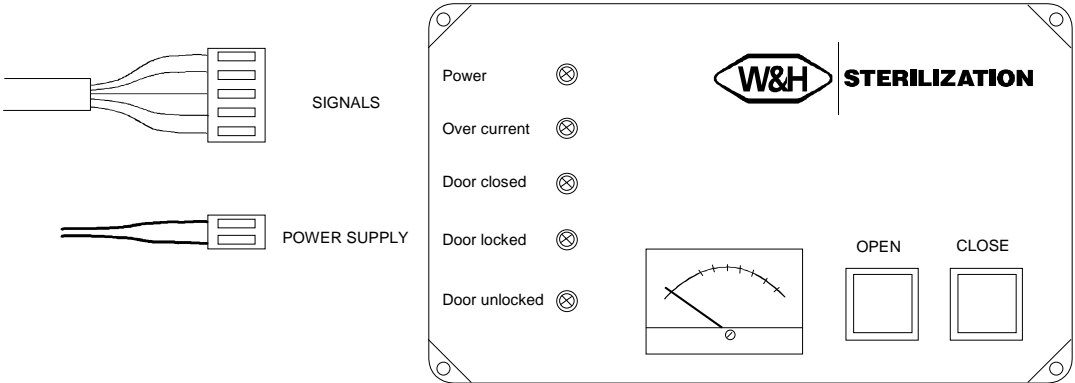
#	Procedures	Tools
1	Remove door locking encoder and motor connectors from CPU board. 	
2	Connect 24V motor supply and encoder plugs to door locking test device. Connect both connectors to sterilizer door locking encoder and motor.	Door test device Lisa Rev. 2.0
		
3	Connect test device to mains and switch it ON. The POWER led is ON. Close the door and verify the DOOR CLOSED LED is switched ON. <b>OPEN</b> and <b>CLOSE</b> door using corresponding test device buttons: The maximum door locking motor consumption must read 0,8 to 0,9A. Check the switching of the DOOR LOCKED and DOOR UNLOCKED LEDs.	
4	If the motor consumption is too high or if the motor cannot lock the door ( DOOR LOCKED LED is OFF) door adjustment is needed. (see Layouts 11, 12 and 13 ) and test the motor consumption again.	
5	Disconnect door test device and plug in both door locking encoder and motor connectors on CPU board.	

**Layout 12 – Adjust Door/Locking Pin Side**

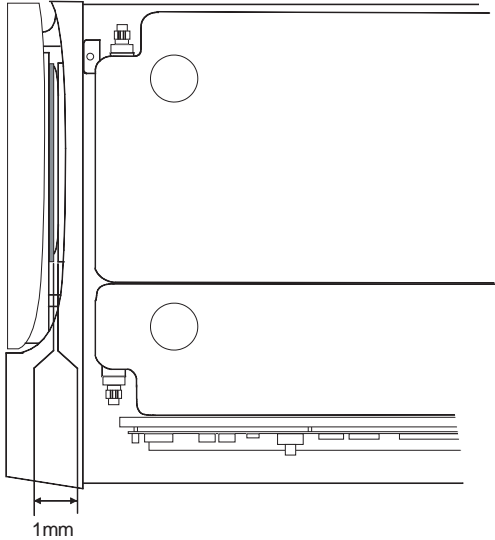
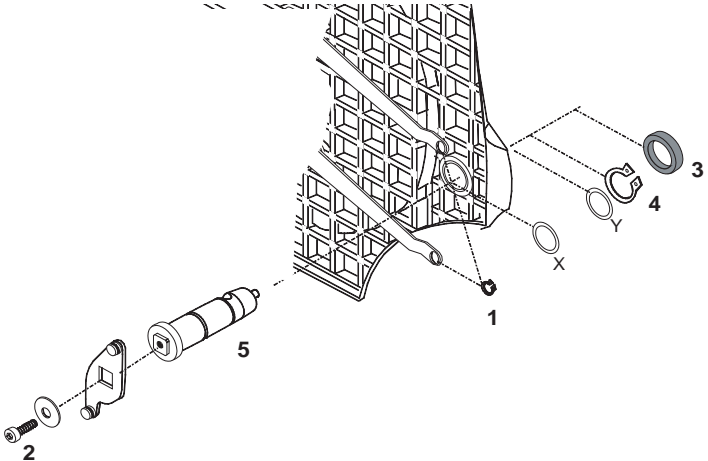
#	Procedures	Tools
<p><b>1</b></p>	<p>Close the door; check the gap between the door seal and the chamber collar. The distance must be +/- 1/32 in (1mm) all around.</p> 	
<p><b>2</b></p>	<p>If a 1/32 in (1mm) gap has not been reached with the porthole spacer ring (see Layout 11) or if the gap is not uniform all around the chamber, the door hinge mounts and/or the locking pin must be adjusted.</p>	
<p><b>3</b></p>	<p>To adjust the door locking pin:</p> <ul style="list-style-type: none"> <li>- Remove the composite door cover (see Layout 2).</li> <li>- Remove both holding clips (1) and screw (2) with a 5mm Allen key.</li> <li>- Remove seal (3) using a screwdriver and the fixing clip (4).</li> <li>- Remove the door locking pin (5) and the X+Y spacer washers.</li> </ul> 	<p>Circlip pliers 5mm Allen key Flat screwdriver</p>

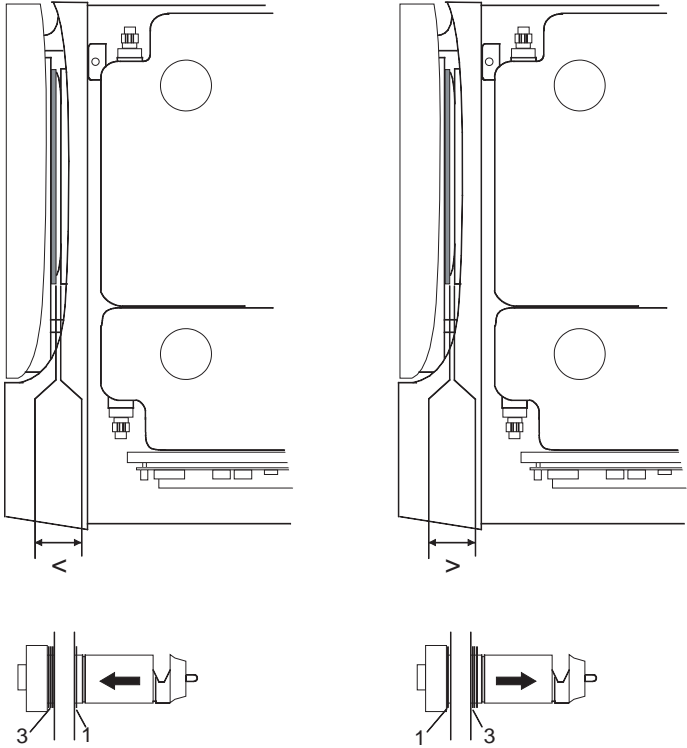

#	Procedures	Tools
<p><b>4</b></p>	<p>Move the locking pin spacer washers on the left or on the right side of the door to reduce or increase the gap between the chamber and the door seal.</p> <p>The total number of washers X+Y must remain equal to the original.</p> 	
<p><b>5</b></p>	<p>Assemble the door following the removal procedure in reverse order.</p> <p>Close the door and check the gap between the door seal and the chamber.</p> <p>Reinstall the seal on the door locking pin (ref. 3).</p>	

**Layout 13 – Adjust Door/Door Hinge Mount**

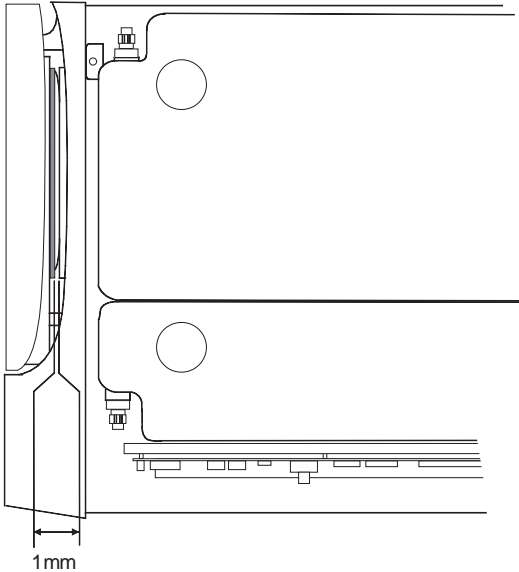
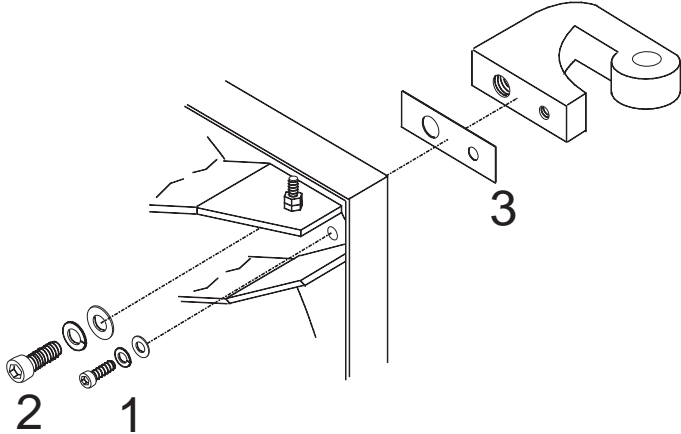
#	Procedures	Tools
<p><b>1</b></p>	<p>Close the door; check the gap between the door seal and the chamber collar. The distance must be +/- 1/32 in (1mm) all around.</p> 	
<p><b>2</b></p>	<p>If the 1/32 in (1mm) gap has not been reached with the porthole spacer ring or if the gap is not uniform all around the chamber, the door hinge mounts and/or the locking pin must be adjusted.</p>	
<p><b>3</b></p>	<p>To adjust the door hinge mount:</p> <ul style="list-style-type: none"> <li>- Remove composite fascia (see Layout 3).</li> <li>- Remove both screws (1) and (2) from one of the two hinges using a 5.5mm and 10mm Allen key, the washers, spacer (3), and hinge.</li> </ul> 	<p>5.5mm Allen key  10mm Allen key</p>

<b>4</b>	Add or remove a spacer to reduce or increase the gap between the chamber and the door seal.	Spacer
<b>5</b>	Fix the hinge and check the gap between the chamber and the door seal. Adjust the second door hinge the same way, if needed.	

**Layout 14 – Remove/Replace Door Locking System**

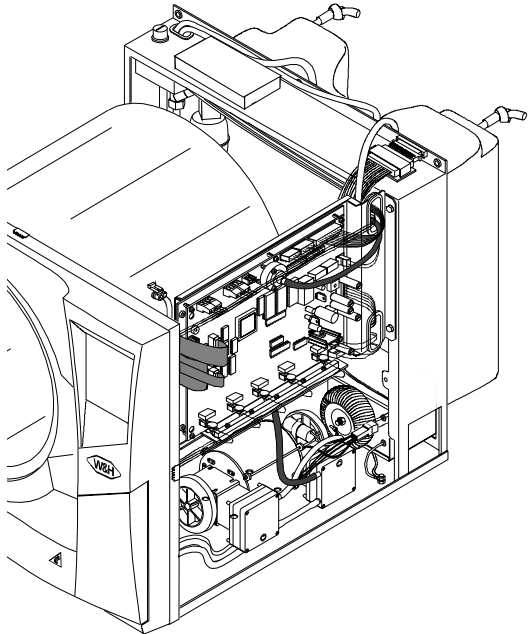
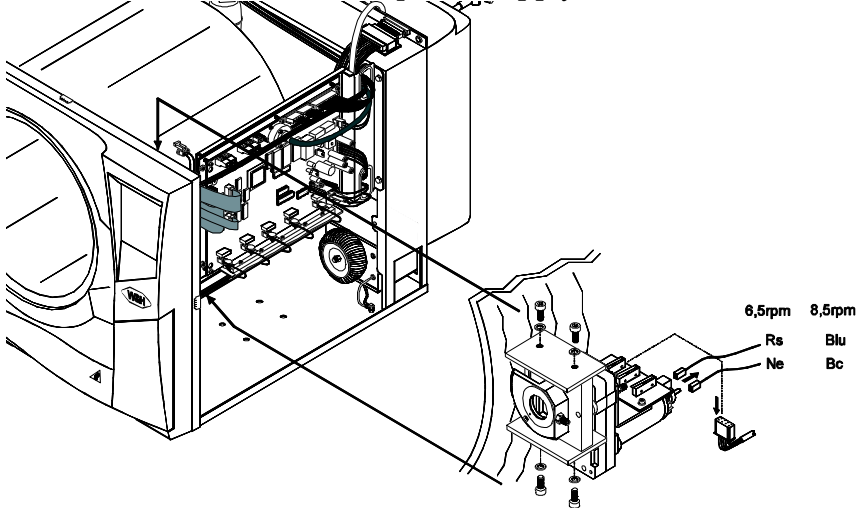
#	Procedures	Tools
<p><b>1</b></p>	<p>Completely drain both water tanks, disconnect the water level sensors, remove the fixing screw and nut (see LAYOUT 9), lift the tank assembly, and remove both drain tubes underneath. Seal both drain connections, turn the tank assembly, and suspend it on the sterilizer rear side as shown.</p> 	<p>Seal cups</p>
<p><b>2</b></p>	<p>Remove the vacuum pump (see LAYOUT 8) to access the screws securing the lower door locking system. Remove the four screws using a 5mm Allen key. Remove both encoder and motor power supply connectors.</p> 	<p>5mm Allen key</p>

**Layout 15 – Remove/Replace Door Locking Switch Board**

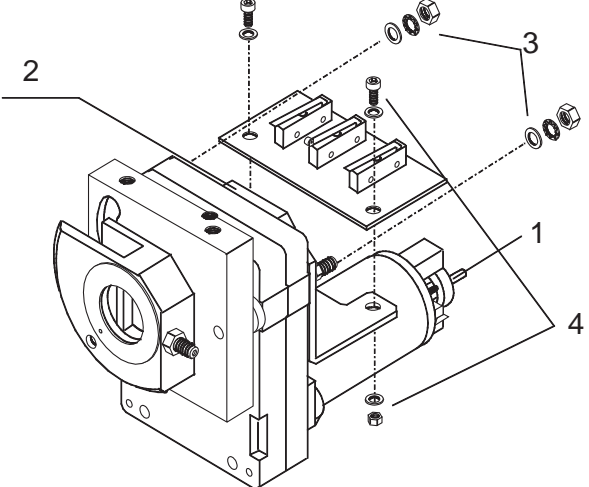
#	Procedures	Tools
<p><b>1</b></p>	<p>Access locking assembly.                      Turn the motor axle (1) to position actuator cam support (2) horizontally.                      Use the 8mm ring spanner to remove nuts and washers securing the door switch board bracket (3).                      Use the 4mm Allen key to remove screws and washers securing the door switch board.</p> 	<p>4mm Allen key  8mm ring spanner</p>
<p><b>2</b></p>	<p>Mount the door locking system and adjust the switches (see LAYOUT 16).</p>	

**Layout 16 – Adjust Door Locking System Switches**

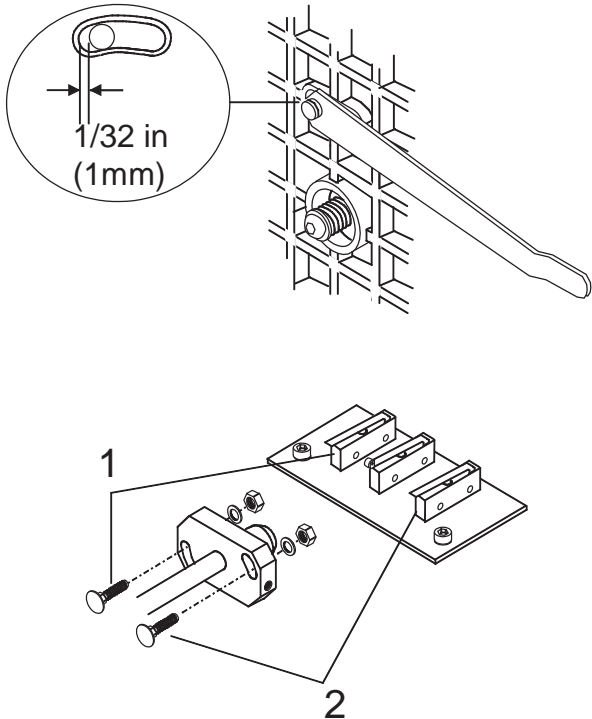
#	Procedures	Tools
<p><b>1</b></p>	<p>Connect door locking test device (see LAYOUT 10).                      Close door and check that the DOOR CLOSED LED is ON.                      Press the test device <b>CLOSE</b> button until the door is locked. Check that the DOOR LOCKED LED is ON.                      The gap between the door locking arm rod and the cast aluminium door window must be about 1/32 in (1mm) (see drawing). If not, adjust the actuating screw (1) using 8mm ring spanner.                      Press the test device <b>OPEN</b> button until the door is unlocked. Check that the DOOR UNLOCKED LED is ON.                      Check to make sure the door opens. If it doesn't, adjust the actuating screw (2) using 8mm ring spanner.  <b>LOCK</b> and <b>UNLOCK</b> the door using the test device buttons The maximum door locking motor consumption must read 0.8 to 0.9A (see LAYOUT 10).</p> 	<p>Door locking test device</p> <p>8mm ring spanner</p>

**Layout 17 – Remove/Replace Mains Filter Pack**

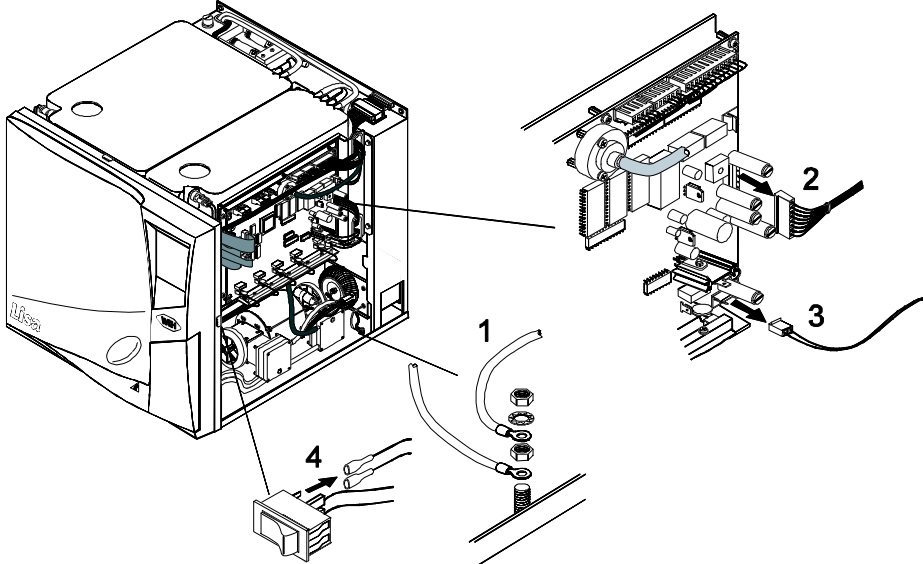
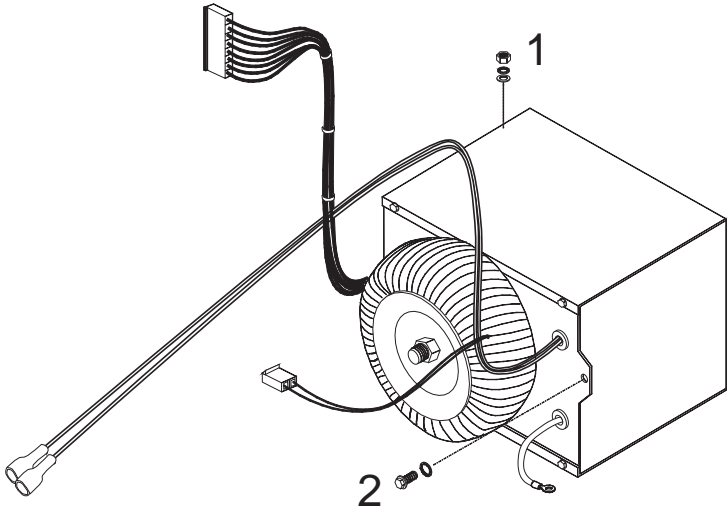
#	Procedures	Tools
<p><b>1</b></p>	<p>Remove earth connector nuts (1) using the 8mm ring spanner. Free the mains earth cable.</p> <p>Remove secondary (2) and mains (3) transformer connectors from CPU board.</p> <p>Remove both cable terminals (4) from the mains switch.</p> <p>Remove cable ties to free the mains cables.</p> 	<p>8mm ring spanner</p>
<p><b>2</b></p>	<p>Remove nut (1) using a 8mm spanner and screw (2) using a 5.5mm spanner.</p> <p>Remove the mains filter pack and cables.</p> 	<p>5.5mm spanner</p> <p>8mm spanner</p>

**Layout 18 – Remove/Replace Rear Cover**

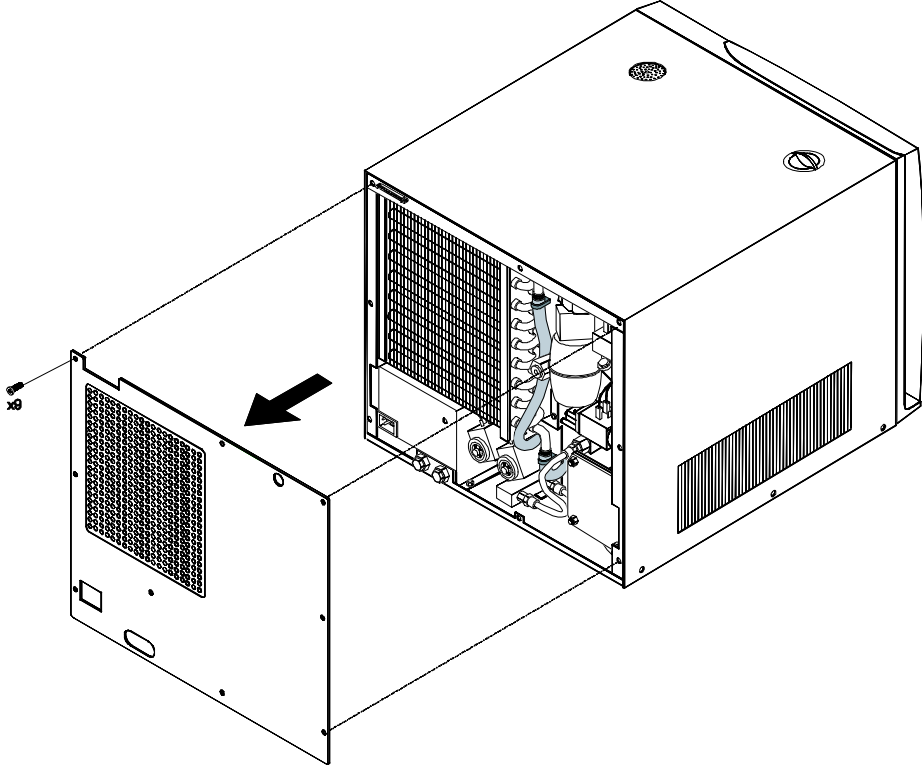
#	Procedures	Tools
<p><b>1</b></p>	<p>Remove the nine screws using a Phillips screwdriver.</p> 	<p>Phillips screwdriver</p>



**Layout 19 – Remove/Replace Steam Generator**

#	Procedures	Tools
<p><b>1</b></p>	<p>Remove both bolts using a 13mm spanner.                      Remove all steam generator <b>A</b> connections with a 12mm spanner and the <b>B</b> connections with a 14mm spanner.                      Disconnect both heating element power supply cable terminals (<b>C</b>).                      Remove temperature sensor (<b>D</b>) fixing clip using a 2.5mm Allen key and the sensor itself.                      Remove overheating circuit breaker (<b>E</b>) fixing clip using a 2.5mm Allen key and the breaker itself.  <b>Attention:</b> pull out the sensors leaning on the metal frame in order to avoid damaging the probes.</p>	<p>12mm spanner                      13mm spanner                      14mm spanner                      2.5mm Allen key</p>
<p><b>2</b></p>	<p>To mount the generator: follow the removal procedure in reverse order.  <b>Attention:</b> if needed use heat conductive silicone grease on both probes.</p>	<p>Silicone grease</p>

**Layout 20 – Replace Steam Generator Heating Element**

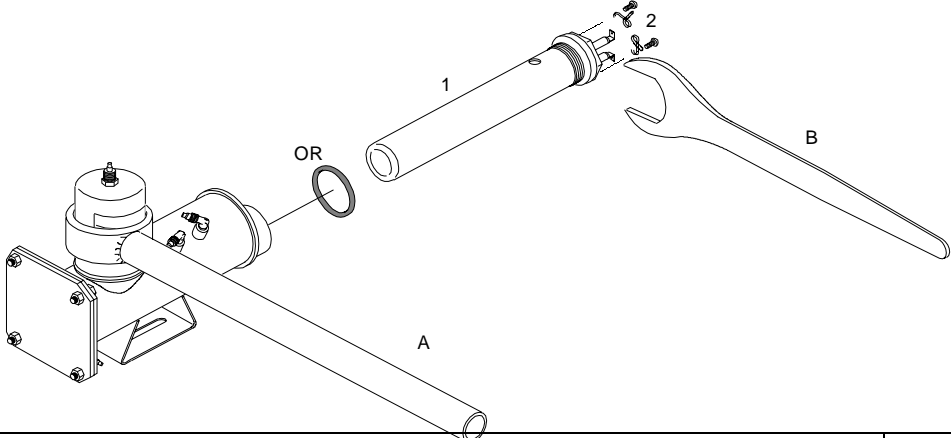
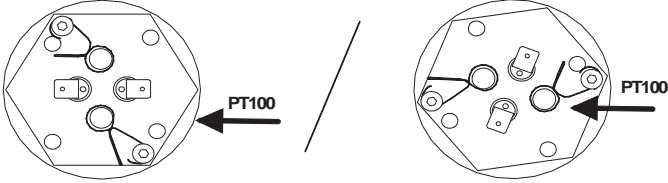
#	Procedures	Tools
<p><b>1</b></p>	<p>If the steam generator was removed, secure it in a vice. If the steam generator is fixed on the machine, use the special tool (A) to hold it in place as shown.                      Remove heating element (1) using the special 40mm spanner.                      Remove O-ring.                      Remove clips (2) through 2.5mm Allen key.</p>	<p>40mm spanner                       Special tool                       2.5mm Allen key</p>
		
<p><b>2</b></p>	<p>Mount a new O-ring on the new heating element.                      Tighten the heating element using a 40mm spanner so that the power supply terminals are vertically oriented.                      Mount screws and clips on the positions as shown.</p>	
<p>Note: For the new types of steam generator, screw the heating element against the metal housing without considering the final direction of the power supply terminals. The PT100 probe should be positioned on the lower hole (see figure). Take care to hold the steam generator in place.</p> 		

**Layout 21 – Remove/Replace Water Pump**

#	Procedures	Tools
1	Disconnect both power supply cable terminals (1). Remove both nuts (2) and washers using a 8mm spanner. Remove fitting (3) using a 12mm spanner. Cut cable tie (6) and remove tube (4). Remove both anti-vibration supports.	8mm spanner 12mm spanner Cutter
2	Replace the water pump by following the removal procedure in reverse order. Connect both cable terminals. Use the colors shown below as a reference.	

**Layout 22 – Calibration CPU Board PT100 & Pressure Transducer**

#	Procedures	Tools
1	<p>Access CPU board.</p> <p><b>The EPROM is an electronic component which could be damaged by electrostatic discharge. Before proceeding, discharge accumulated electrostatic voltage by touching an earth-connected point.</b></p> <p>Remove connectors X1, X2, X3, and X4 from CPU board.</p> <p>Remove jumper X7.</p> <p>Place calibration board over CPU holding plate as shown.</p> <p>Connect CPU and calibration board connectors as shown.</p>	<p>Calibration board</p>

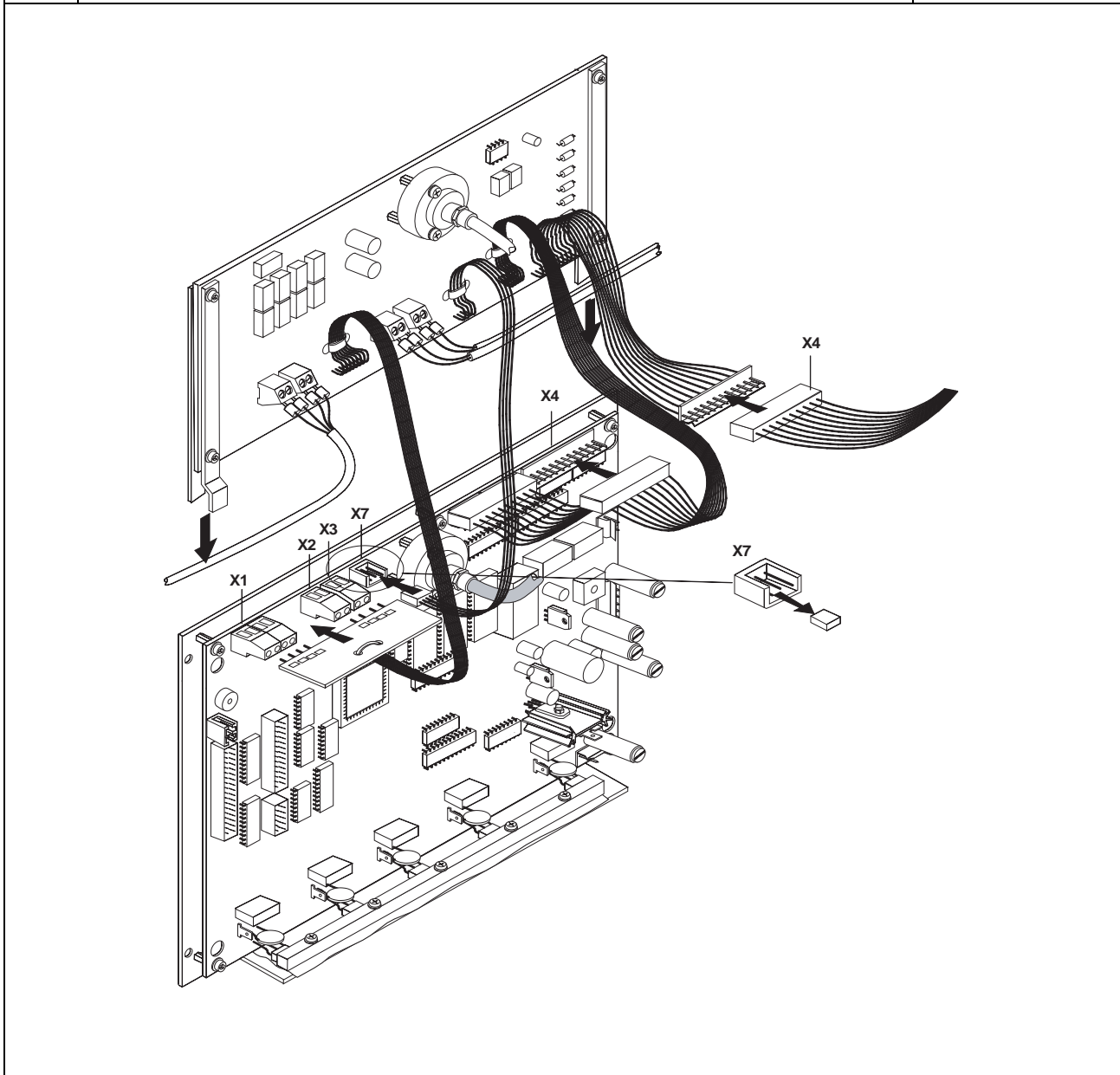

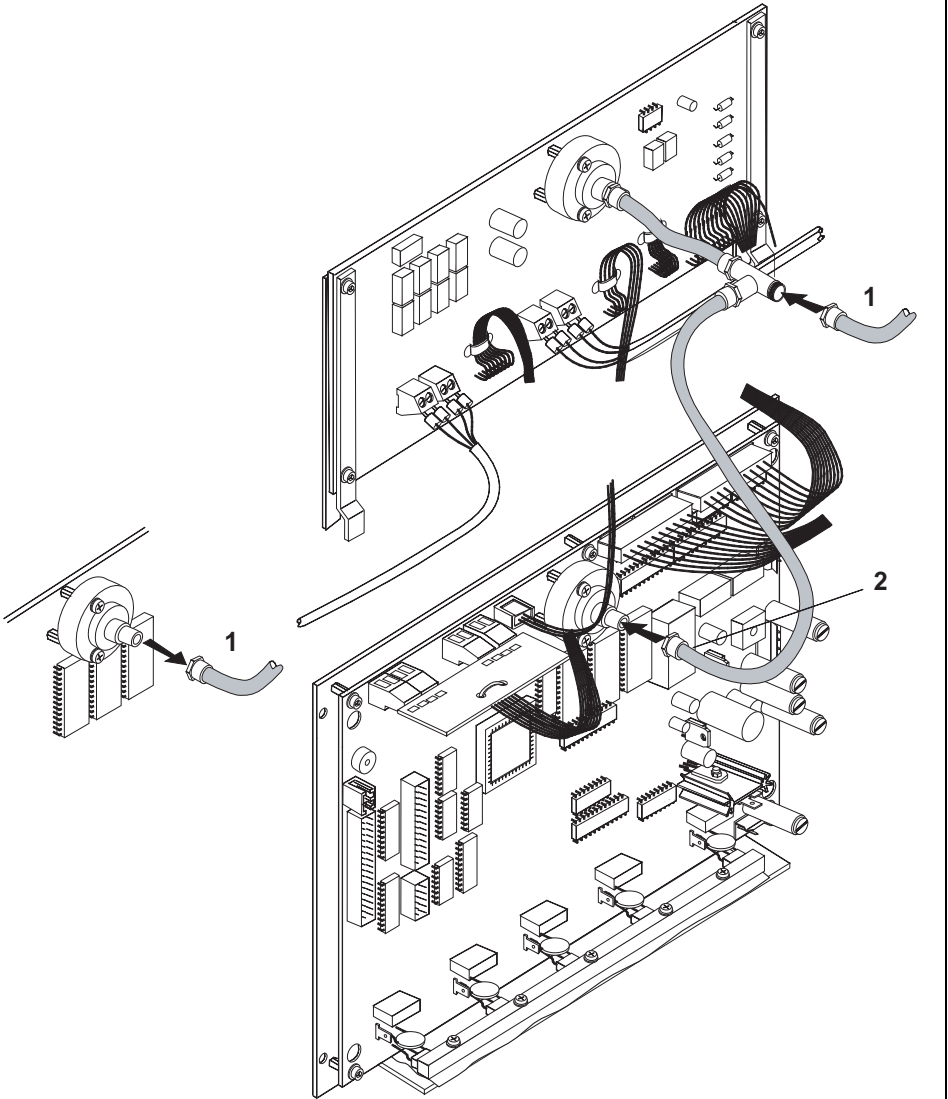
#	Procedures	Tools
2	Remove tube (1) from CPU pressure sensor and connect it on the manifold. Connect the manifold free tube (2) to the CPU pressure sensor.	
 <p>The diagram is an exploded view of the Lisa Sterilizer's CPU assembly. It shows the main CPU board with various components like chips, connectors, and a pressure sensor. A grey tube labeled '1' is shown being disconnected from the CPU pressure sensor. Another grey tube labeled '2' is shown being connected to the manifold. The diagram is a technical illustration with clear lines and labels.</p>		

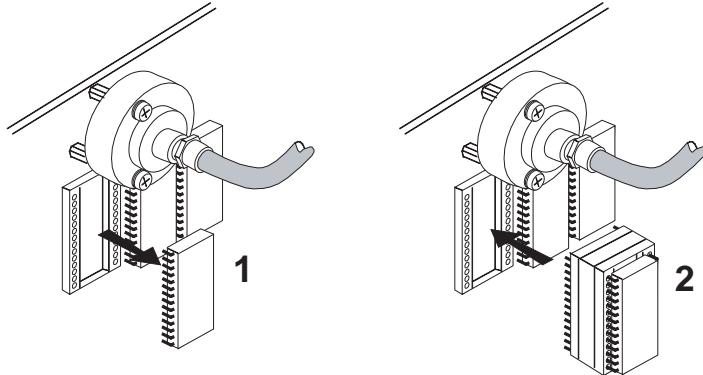
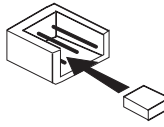
#	Procedures	Tools
<p><b>3</b></p>	<p>Replace "EU x.x" program EPROM (1) with service EPROM (2).</p> 	<p>Service EPROM N°2</p>
<p><b>4</b></p>	<p>Switch the sterilizer ON and follow the displayed instructions. Calibration is fully automatic. At the end of the calibration cycle, switch the sterilizer OFF.</p> <p>Replace the service EPROM with the "US x.x" EPROM.</p> <p>Disconnect and remove the calibration board. Connect CPU board as originally connected.</p> <p>Remember to insert the jumper on pin 1-2 of X7.</p> 	

**Layout 23 – Remove/Replace CPU Board**

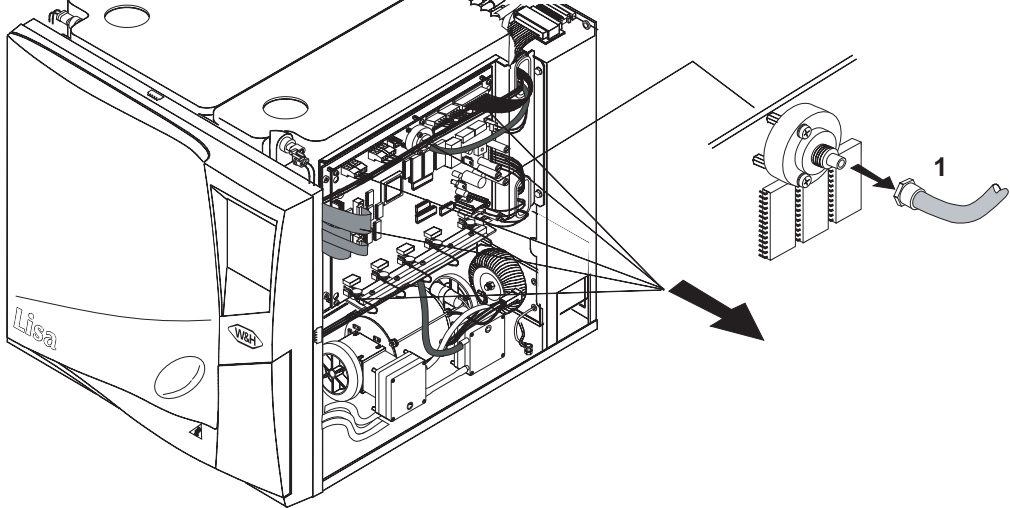
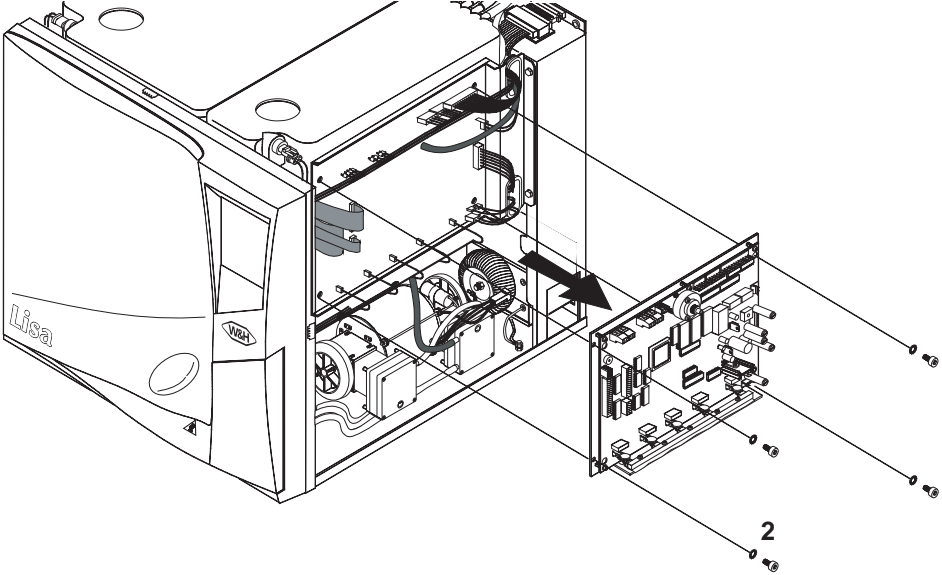
#	Procedures	Tools
<p><b>1</b></p>	<p>Access CPU board.  <b>The EPROM is an electronic component which could be damaged by electrostatic discharge. Before proceeding, discharge accumulated electrostatic voltage by touching an earth-connected point.</b>                      Remove all connectors and connections from CPU board.                      Remove the pressure sensor tube (1).</p>	
 <p>The diagram shows a cutaway view of the Lisa sterilizer's interior. A callout box on the right shows a close-up of a pressure sensor tube (labeled '1') being removed from a component on the CPU board. An arrow points from the callout to the corresponding location in the main cutaway view.</p>		
<p><b>2</b></p>	<p>Use a 3mm Allen key to remove the four screws and washers securing the CPU board metal carrier.</p>	<p>3mm Allen key</p>
 <p>The diagram shows a cutaway view of the Lisa sterilizer's interior. A callout box on the right shows the CPU board metal carrier being removed from the chassis. Four screws and washers are shown being removed from the carrier, with arrows pointing to their locations on the carrier. The number '2' is placed near the carrier in the cutaway view.</p>		
<p><b>3</b></p>	<p>To mount: follow the removal procedure in reverse order.</p>	<p>3mm Allen key</p>

**Layout 24 – Remove/Replace Printer Interface**

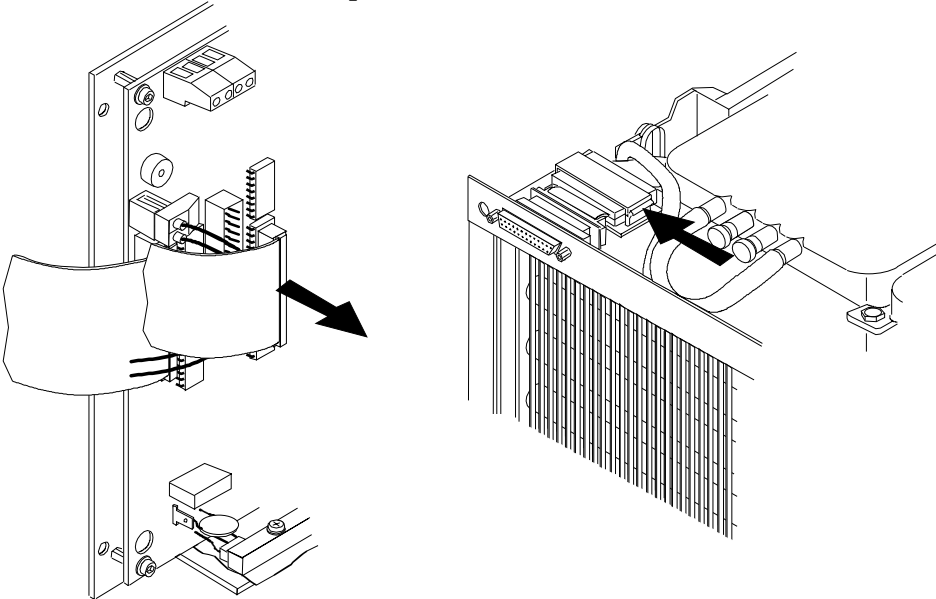
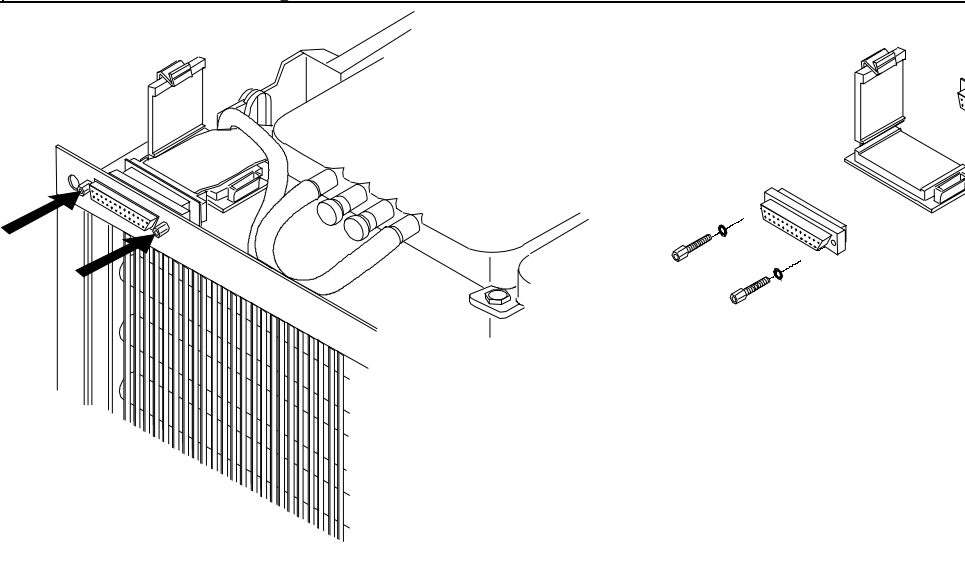
#	Procedures	Tools
<p><b>1</b></p>	<p>Access CPU board. Remove the flat printer cable from the CPU board. Press the EMC ferrite lever to free the flat printer cable.</p> 	
<p><b>2</b></p>	<p>Remove screws and washers securing the EMC filter. Disconnect the flat printer cable connector from the EMC filter.</p>	<p>5mm spanner</p>
		
<p><b>3</b></p>	<p>To mount the new flat cable: follow the removal procedure in reverse order.</p>	<p>5mm spanner</p>

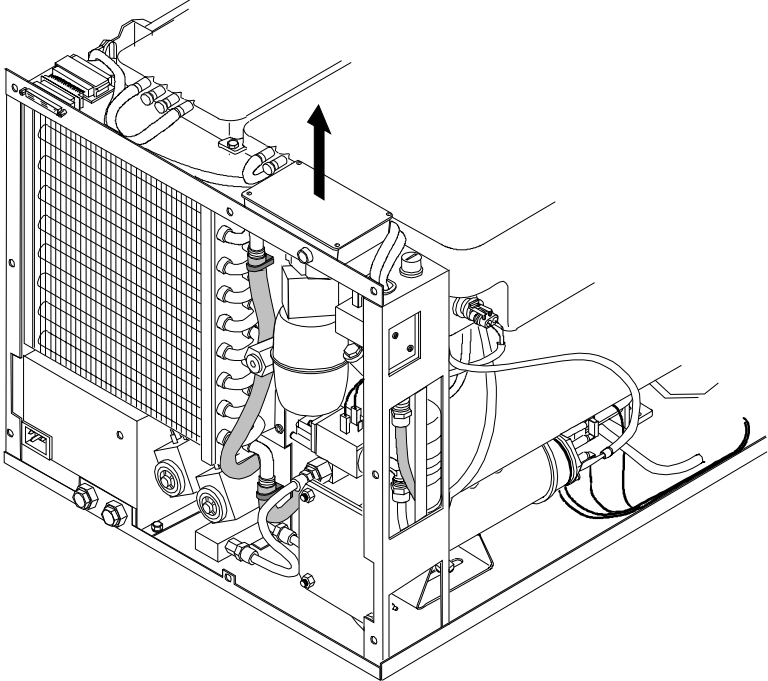
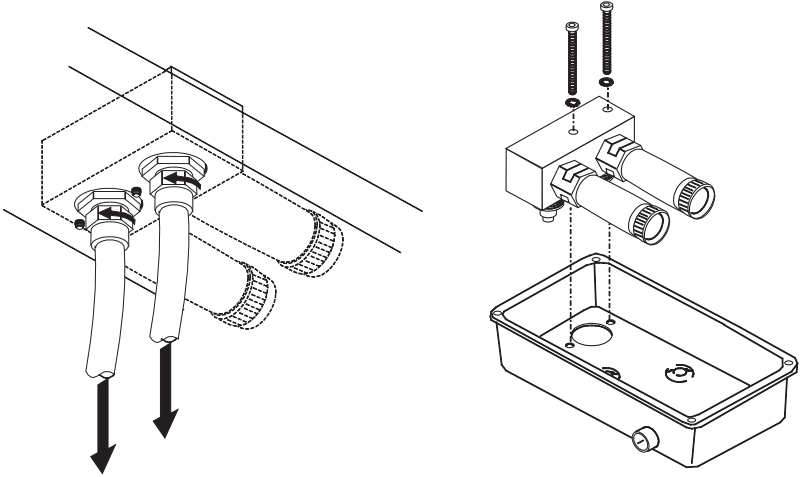

**Layout 25 – Replace Pressure Safety Valves Housing**

#	Procedures	Tools
<p><b>1</b></p>	<p>Remove the four screws securing the housing cover.</p> 	<p>Phillips screwdriver</p>
<p><b>2</b></p>	<p>Remove both safety valve connections. Remove the screws and washers securing both safety valves.</p> 	<p>Phillips screwdriver 12/14mm spanners</p>
<p><b>3</b></p>	<p>To mount the housing: follow the removal procedure in reverse order.</p>	

**Layout 26 – Remove/Replace EV2-EV4 Subset**

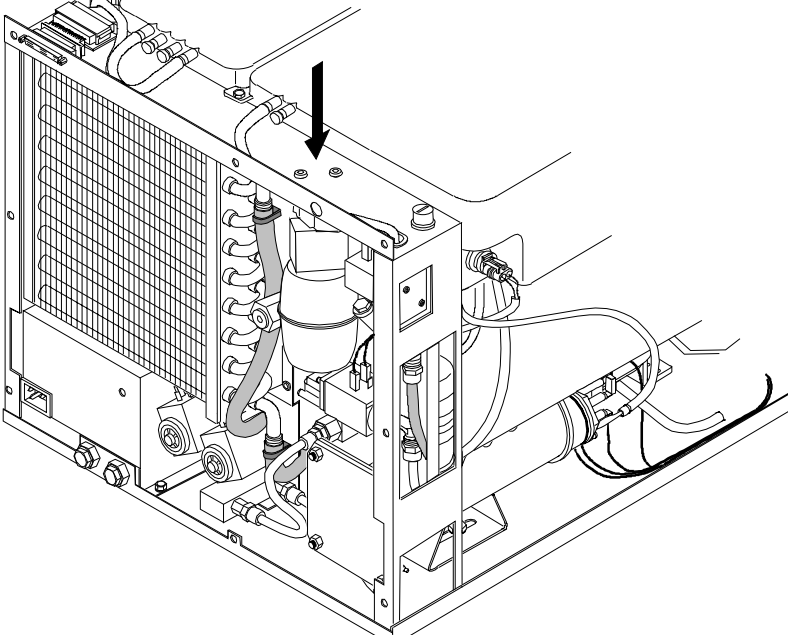
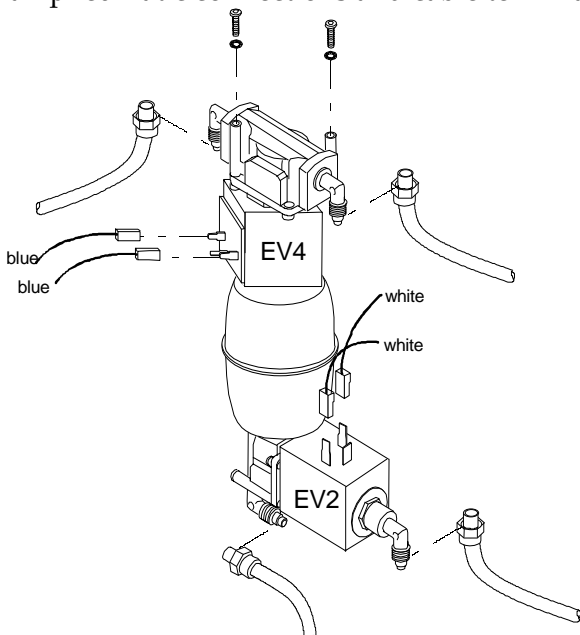
#	Procedures	Tools
<p><b>1</b></p>	<p>Remove pressure safety valves housing (see Layout 25). Remove both subset screws and washers located underneath.</p> 	<p>Phillips screwdriver</p>
<p><b>2</b></p>	<p>Remove all pneumatic connections and cable terminals as shown.</p> 	<p>Phillips screwdriver</p>
<p><b>3</b></p>	<p>To mount the subset: follow the removal procedure in reverse order.</p>	

**Layout 27 – Replace External Chamber PT100 T° Sensor**

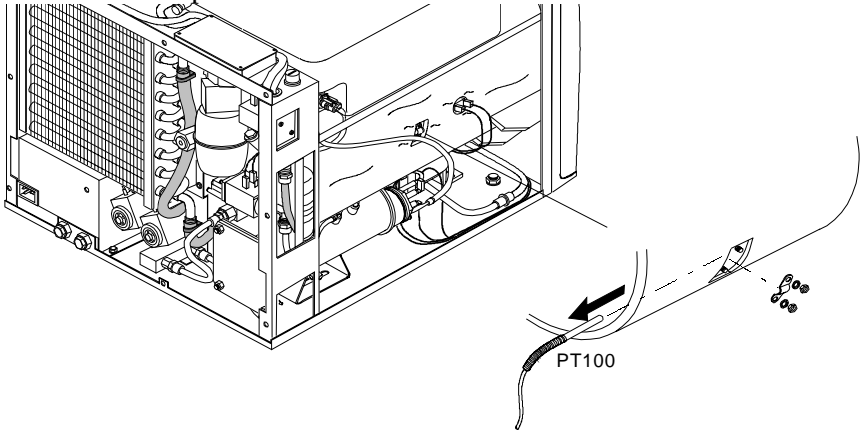
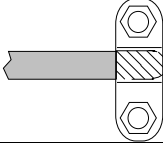
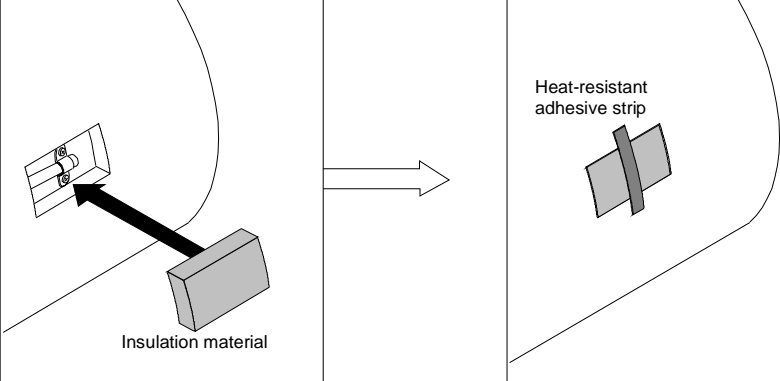
#	Procedures	Tools
<p><b>1</b></p>	<p>Remove housing to access sensor located on the left-hand side of the sterilizer.                      Remove adhesive strip.                      Use 8mm ring spanner to unscrew both PT100 fixing bracket screws.                      Pull out the temperature sensor.</p> 	<p>8mm ring spanner</p>
<p><b>2</b></p>	<p>Mount and fix the new sensor as shown. The sensor end must not go over the bracket edge.</p> 	
<p><b>3</b></p>	<p>If insulation material is missing, cut a piece of insulation material (Acusticell) slightly bigger than the dimensions of the open window where the PT100 is located. Insert the insulation material completely close this window. Fix it using a heat resistant adhesive strip. Replace the program EPROM with a version equal to or higher than EU 5.7 (see Layout 31).</p>	
		

**Layout 28 – Replace EV5 Subset**

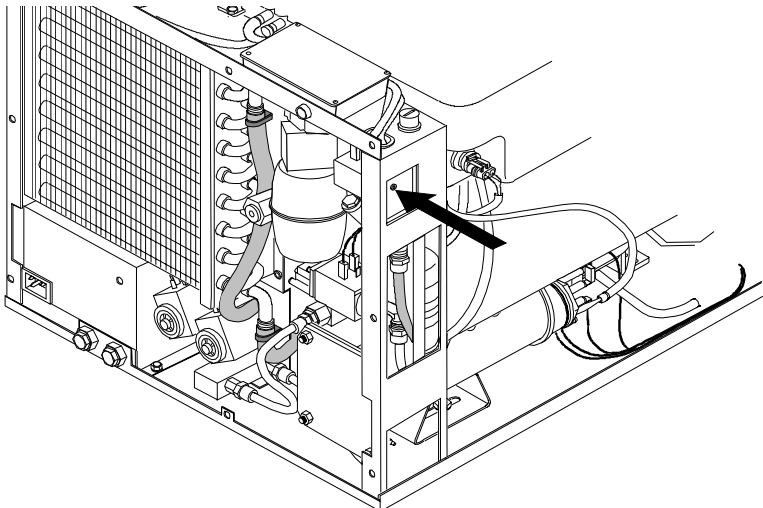
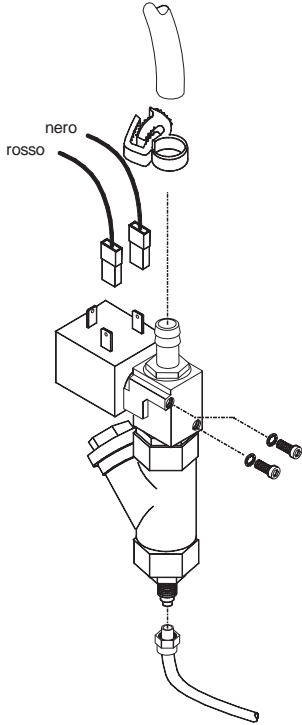
#	Procedures	Tools
<p><b>1</b></p>	<p>Access the EV5 subset.</p> 	
<p><b>2</b></p>	<p>Remove both screws and washers securing the EV5 subset. Remove the pneumatic connections and cable terminals as shown.</p> 	<p>2.5mm Allen key 12mm spanner</p>
<p><b>3</b></p>	<p>To mount the subset: follow the removal procedure in reverse order.</p>	

**Layout 29 – Replace Steam Generator Thermal-Overload**

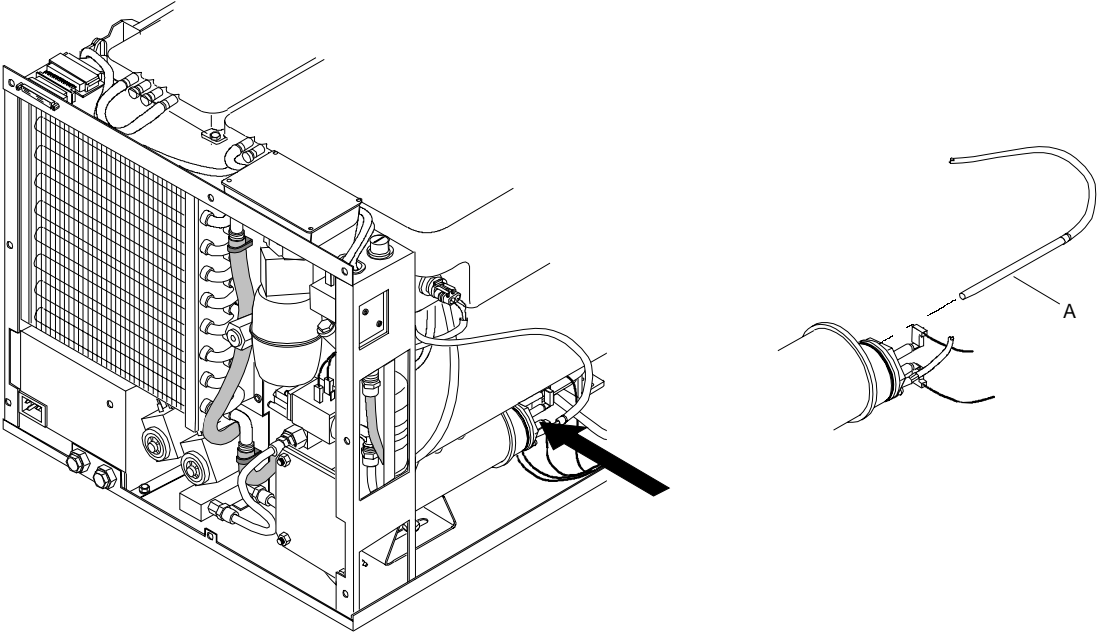
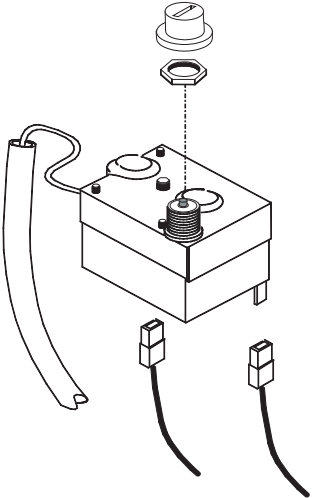
#	Procedures	Tools
1	Remove holding clip. Pull the thermal-overload sensor (A) out from the steam generator.	
		
2	Remove thermal-overload black protection cap. Remove the nut using a 14mm spanner. Remove both mains cable terminals.	14mm spanner
		
3	To mount: follow the removal procedure in reverse order.	

**Layout 30 – Replace Condenser and Condenser Fan**

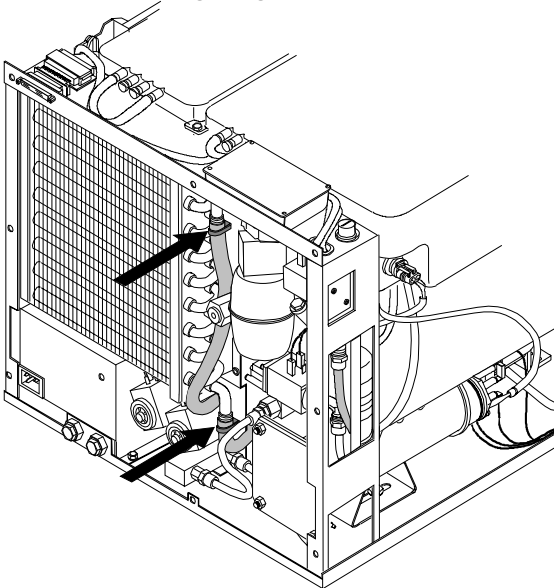
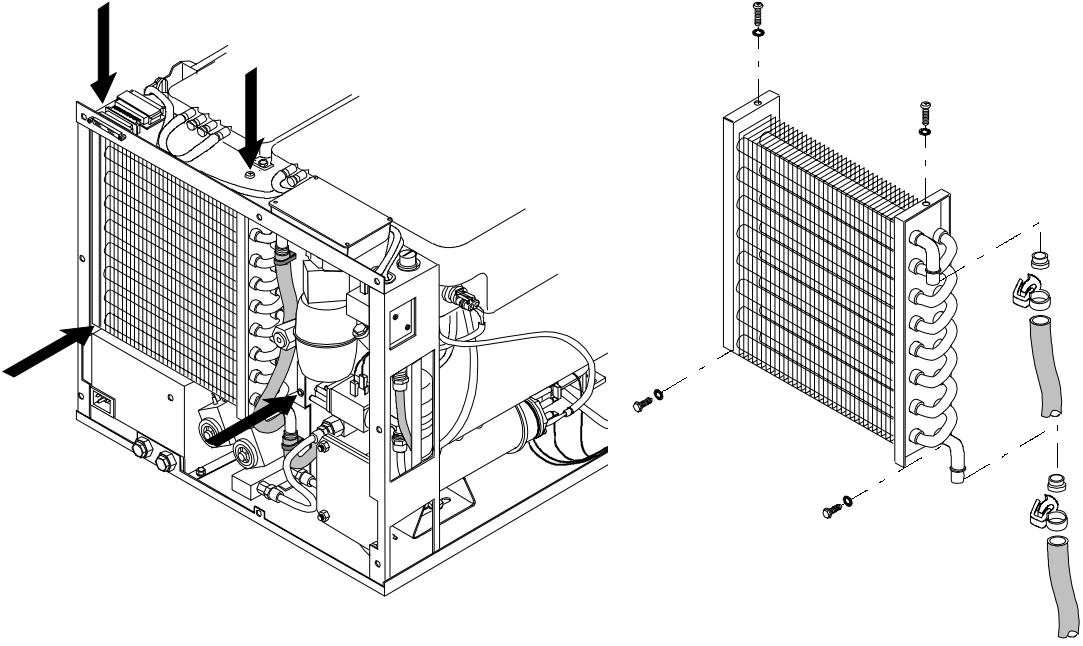
#	Procedures	Tools
<p><b>1</b></p>	<p>Remove housing and rear housing plate to access condenser. Remove both tube clamping rings.</p> 	<p>Flat screwdriver</p>
<p><b>2</b></p>	<p>Remove both upper screws using a Phillips screwdriver and both lower screws using a 5.5mm ring spanner.</p>	<p>Phillips screwdriver  5.5mm ring spanner</p>
		
<p><b>3</b></p>	<p>Remove both fan mains cable terminals.</p>	<p>Phillips</p>

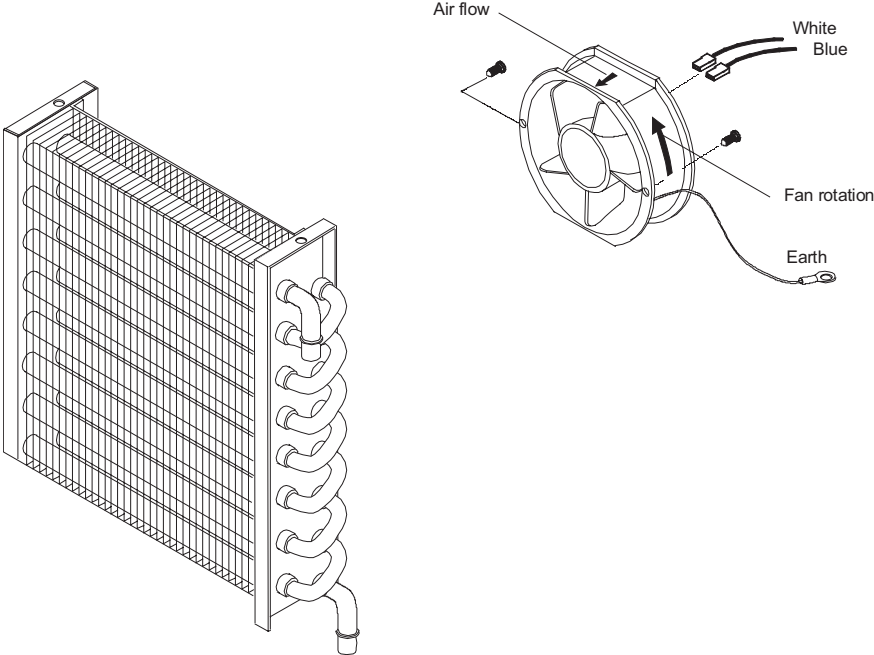
#	Procedures	Tools
	Remove the four or two screws securing the fan.	screwdriver
		
<b>4</b>	To mount: follow the removal procedure in reverse order, paying attention to air flow and rotation direction indicated on the fan.	

**Layout 31 – Replace EPROM**

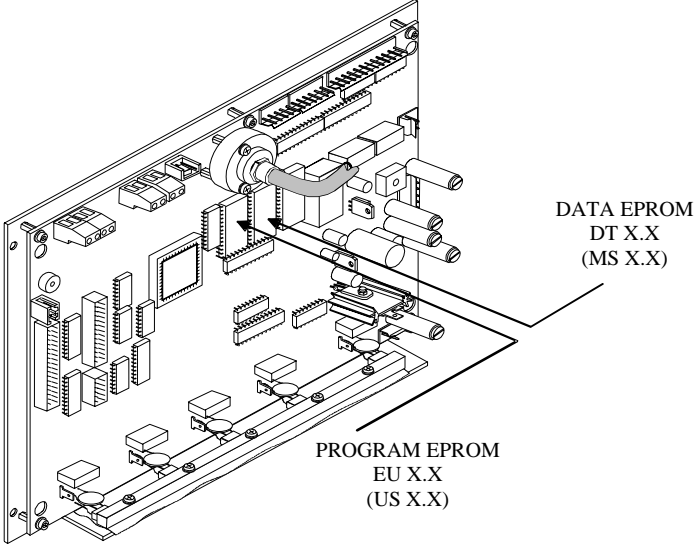
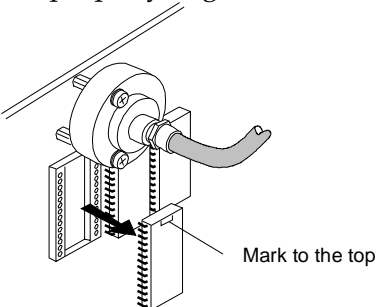
#	Procedures	Tools
<p><b>1</b></p>	<p>The procedure applies to the replacement of:</p> <ul style="list-style-type: none"> <li>• Program EPROM (located on the upper left side of CPU board)</li> <li>• Data EPROM (located on the upper right side of CPU board);</li> </ul> <p><b>The EPROM is an electronic component which could be damaged by electrostatic discharge. Before proceeding, discharge accumulated electrostatic voltage by touching an earth-connected point.</b></p> 	
<p><b>2</b></p>	<p>Make sure that sterilizer is switched OFF (unplug the mains cable for safety).</p> <p><b>Removing the EPROM without switching the sterilizer OFF could cause loss of CPU board calibration</b></p> <p>Remove the EPROM using the proper extraction tool.</p> <p>Insert the new EPROM, making sure that the mark is positioned to the top.</p> <p>Assure all contacts are properly aligned as the EPROM is inserted.</p> 	<p>EPROM extraction tool, Model KE2</p>
<p><b>3</b></p>	<p>Connect the mains cable and switch the sterilizer ON.</p>	

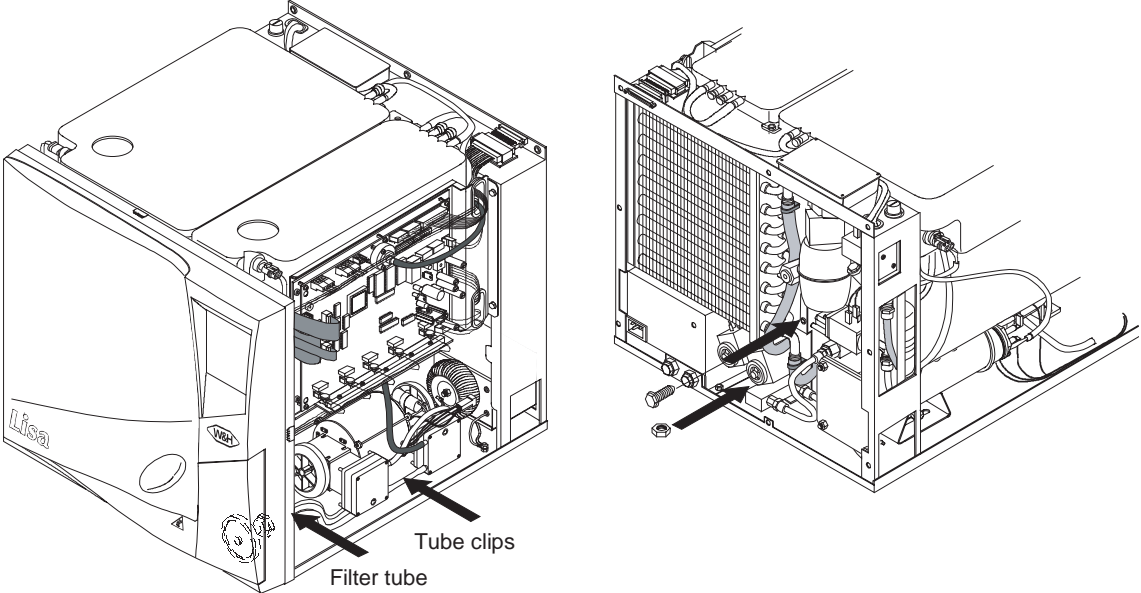
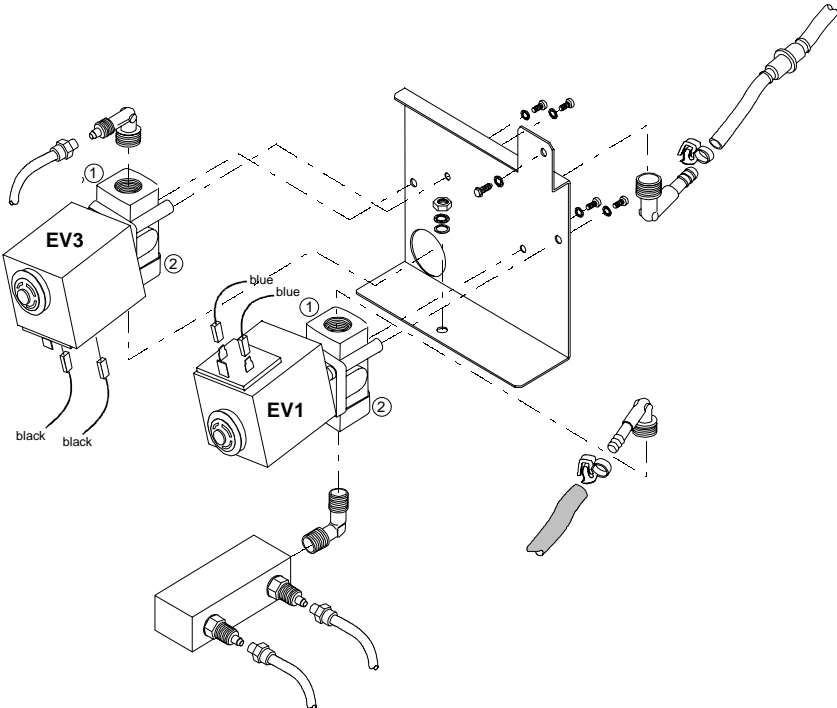

**Layout 32 – Remove/Replace EV1-EV3 Subset**

#	Procedures	Tools
1	Remove filter tubing connection and cable ties. On the rear side, remove both subset fixing screws using a 5.5mm ring spanner (condenser side) and an 8mm ring spanner (frame side).	5.5 and 8mm ring spanners
		
2	Remove the subset. Remove all connections and cable terminals.	12mm special spanner
		

**Layout 33 – Replace Vacuum Pump Membrane Kit**

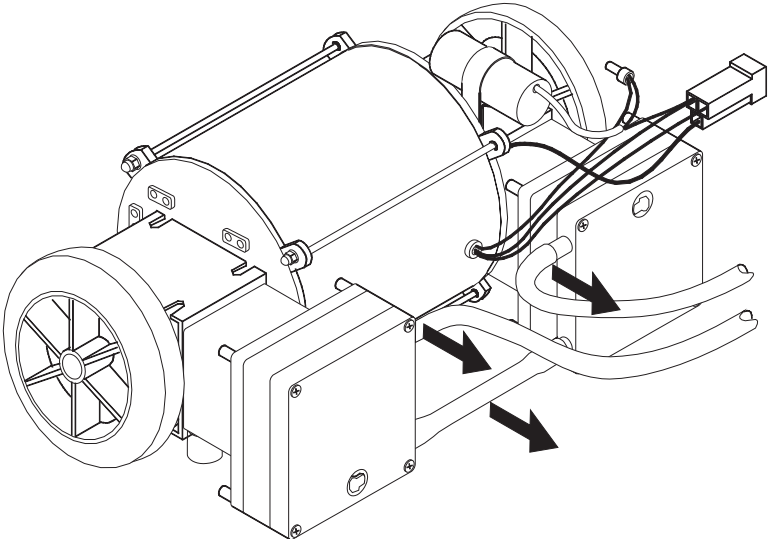
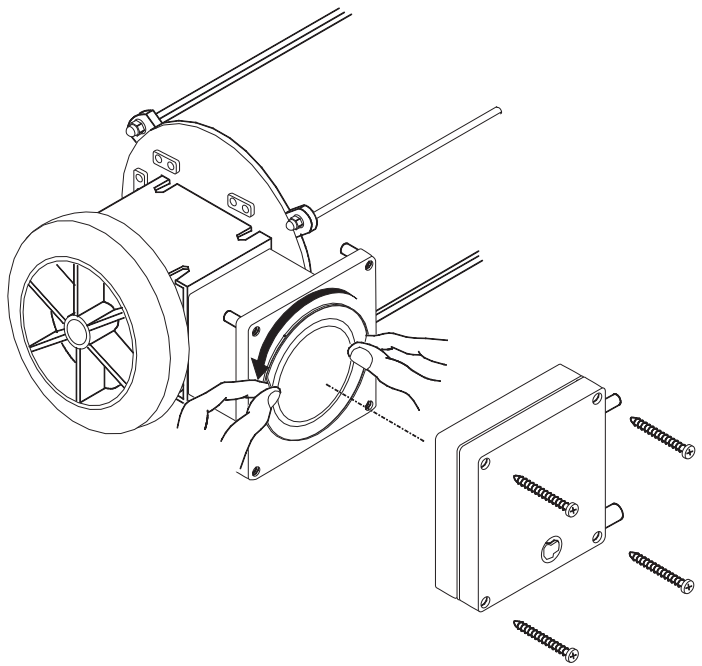
#	Procedures	Tools
<p><b>1</b></p>	<p>Disconnect the vacuum pump head tubing. Remove the pump (see Layout 8).</p> 	
<p><b>2</b></p>	<p>Remove the screws securing the 2x4 vacuum pump head. Unscrew the diaphragms as shown.</p> 	<p>Phillips screwdriver</p>

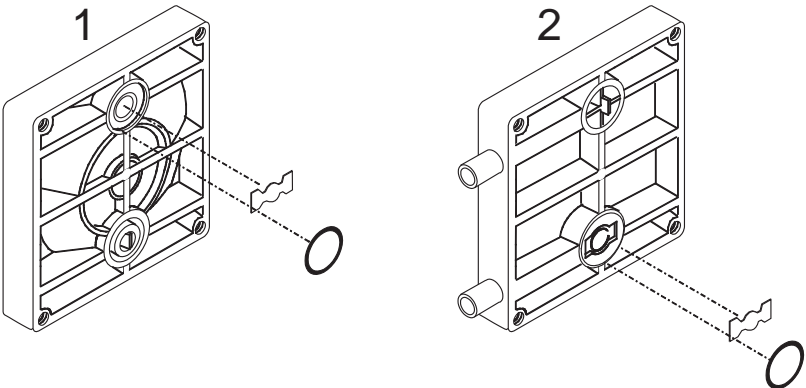
#	Procedures	Tools
<p><b>3</b></p>	<p>Separate the vacuum pump head blocks and use a very small flat screwdriver to replace both O-rings and valves.</p> 	<p>Small flat screwdriver</p>
<p><b>4</b></p>	<p>To mount the head:</p> <ol style="list-style-type: none"> <li>1. Firmly tighten the diaphragms.</li> <li>2. Turn the vacuum pump axle to place the diaphragms in the lowest position. Assemble the head blocks.</li> <li>3. Mount the head and the four screws. Don't tight the screws; leave a 1/32 in (1mm) gap.</li> <li>4. Rotate the vacuum pump axle a few turns to move and position the diaphragms correctly within the head.</li> <li>5. Tighten the four screws.</li> </ol>	

**Layout 34 – Replace EV1-3 Coil and Solenoid**

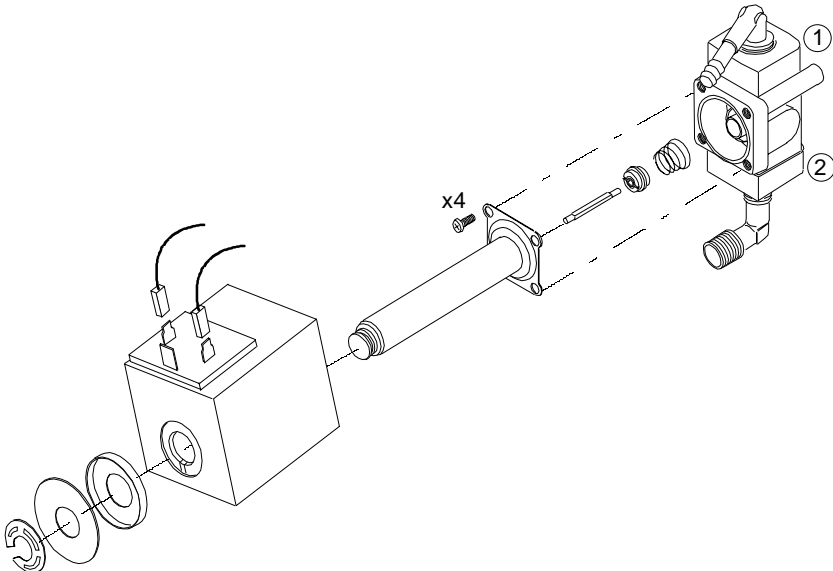
#	Procedures	Tools
<p><b>1</b></p>	<p>Remove EV1-EV3 subset and dismantle each electro-valve as shown</p> 	<p>Phillips screwdriver</p>
<p><b>2</b></p>	<p>To mount valve: follow the removal procedure in reverse order.</p>	

**Layout 35 – Remove Rear Support Frame**

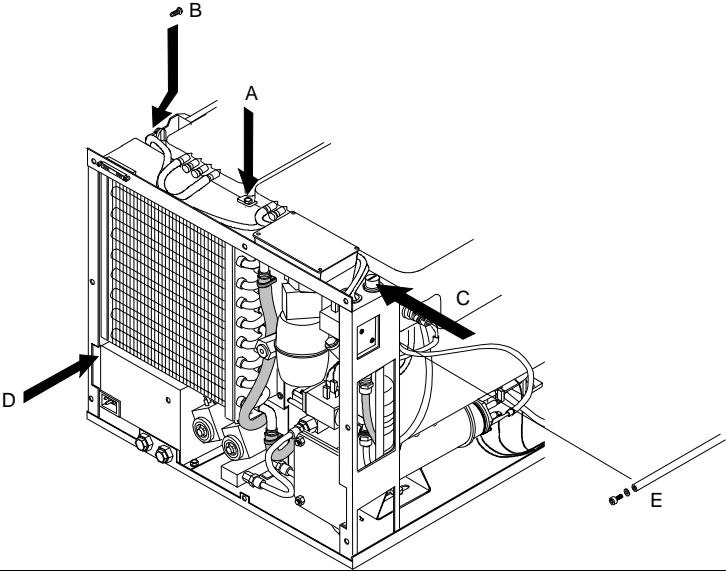
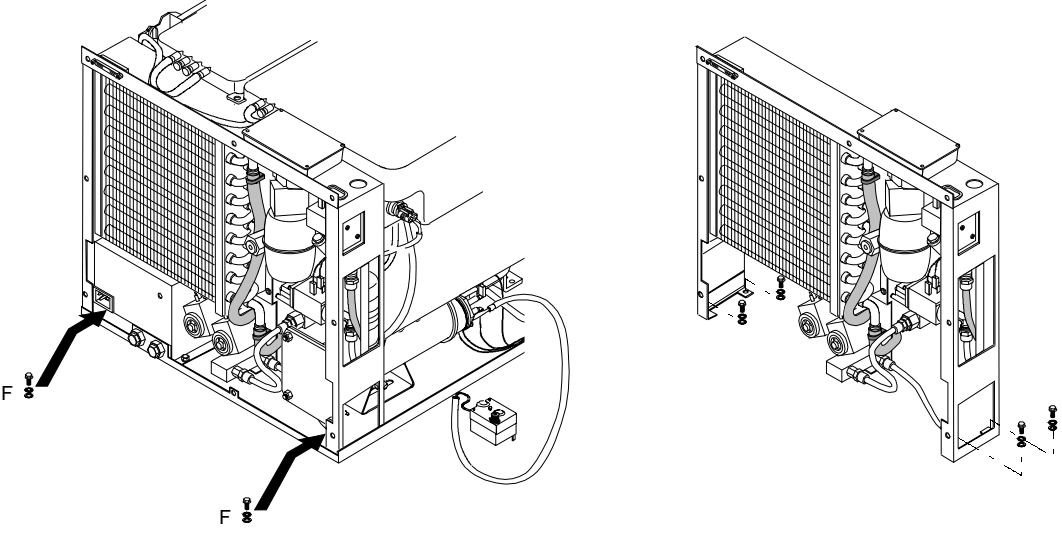
#	Procedures	Tools
<p><b>1</b></p>	<p>Remove printer interface (see Layout 24). Use the special 12mm spanner to remove all tubing from the subsets mounted on the rear support frame. Remove the screw retaining the water tank (A). Remove both screws securing the CPU board metal carrier (B). Remove the steam generator thermal-overload (C). Remove the screw securing the mains filter pack (D). Remove the screw securing the reinforcing bar (E).</p> 	<p>Special 12mm spanner  5.5mm spanner  8mm T spanner</p>
<p><b>2</b></p>	<p>Remove the four screws and washers securing the rear support frame (F).</p>	<p>8mm T spanner</p>
<p><b>3</b></p>		
	<p>To mount: follow the removal procedure in reverse order.</p>	

**Layout 36 – Replace Composite Service Door**

#	Procedures	Tools
1	Move the sterilizer forward to the edge of a table/support and open the service door. Insert the flat screwdriver sharp edge into the service door hinge split. Push the pin out by tapping with hammer.	Small flat screwdriver  Hammer
2	To mount: Insert the service door upper hinge, insert the pin in the lower hinge, and secure it by light tapping with hammer.	Small flat screwdriver  Hammer

**Layout 37 – Replace Chamber Internal PT100 T° Sensor**

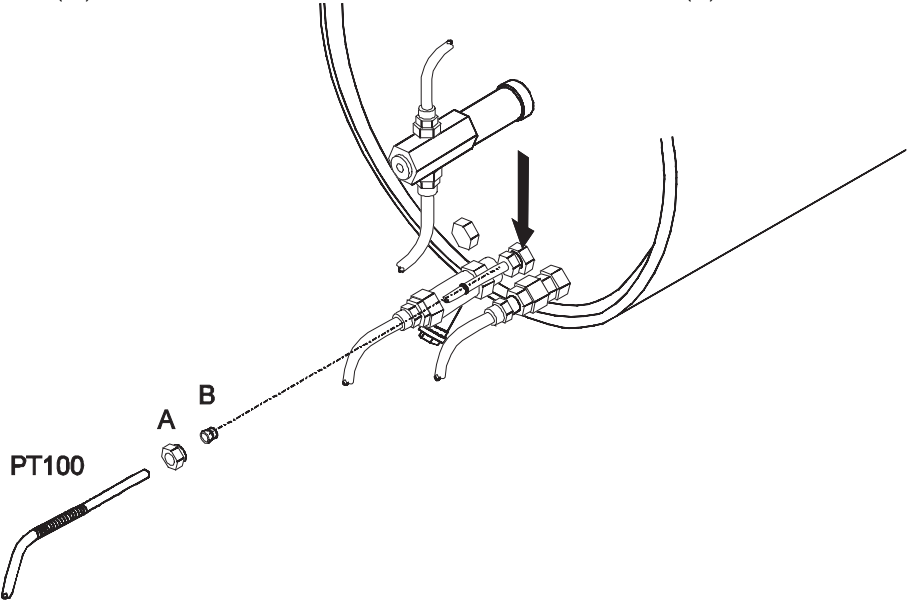
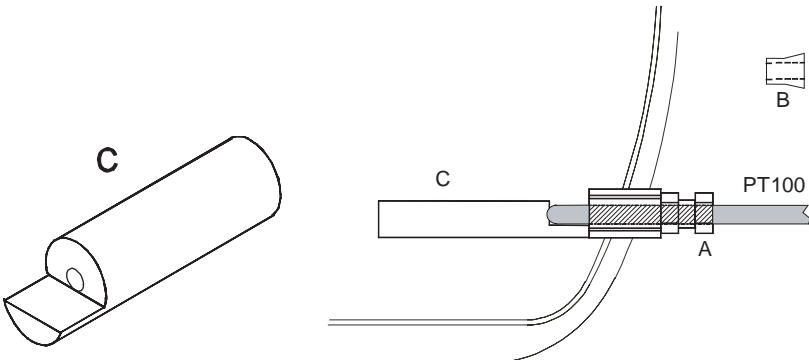
#	Procedures	Tools
<p><b>1</b></p>	<p>To access the rear part of the sterilizer, use a 12mm spanner to remove the nut (A). Remove the sensor, nut, and the Teflon seal (B).</p> 	<p>12mm spanner</p>
<p><b>2</b></p>	<p>To mount: Insert the sensor, the nut (A) and the Teflon seal (B) as shown. Screw the nut on by hand. Place the special gauge (C) inside the chamber against the sensor fitting as shown to get the right position. Screw the nut (A) tight.</p> 	<p>Calibrated gauge 12mm spanner</p>

**Layout 38 – Replace Chamber Thermal-Overload Switch**

#	Procedures	Tools
1	To access the chamber thermal-overload, remove both cable terminals. The thermal-overload is screwed into the heating element.	

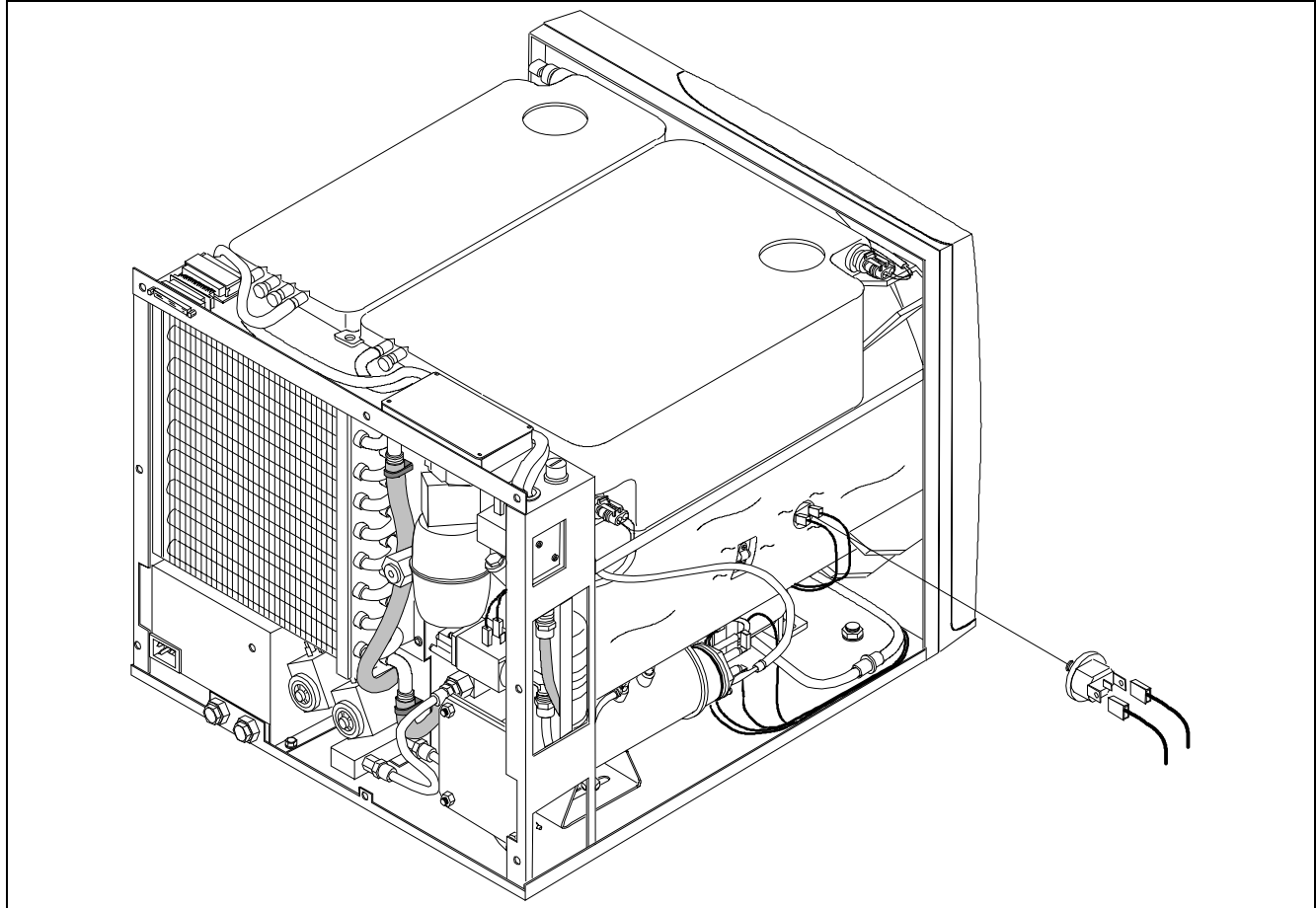

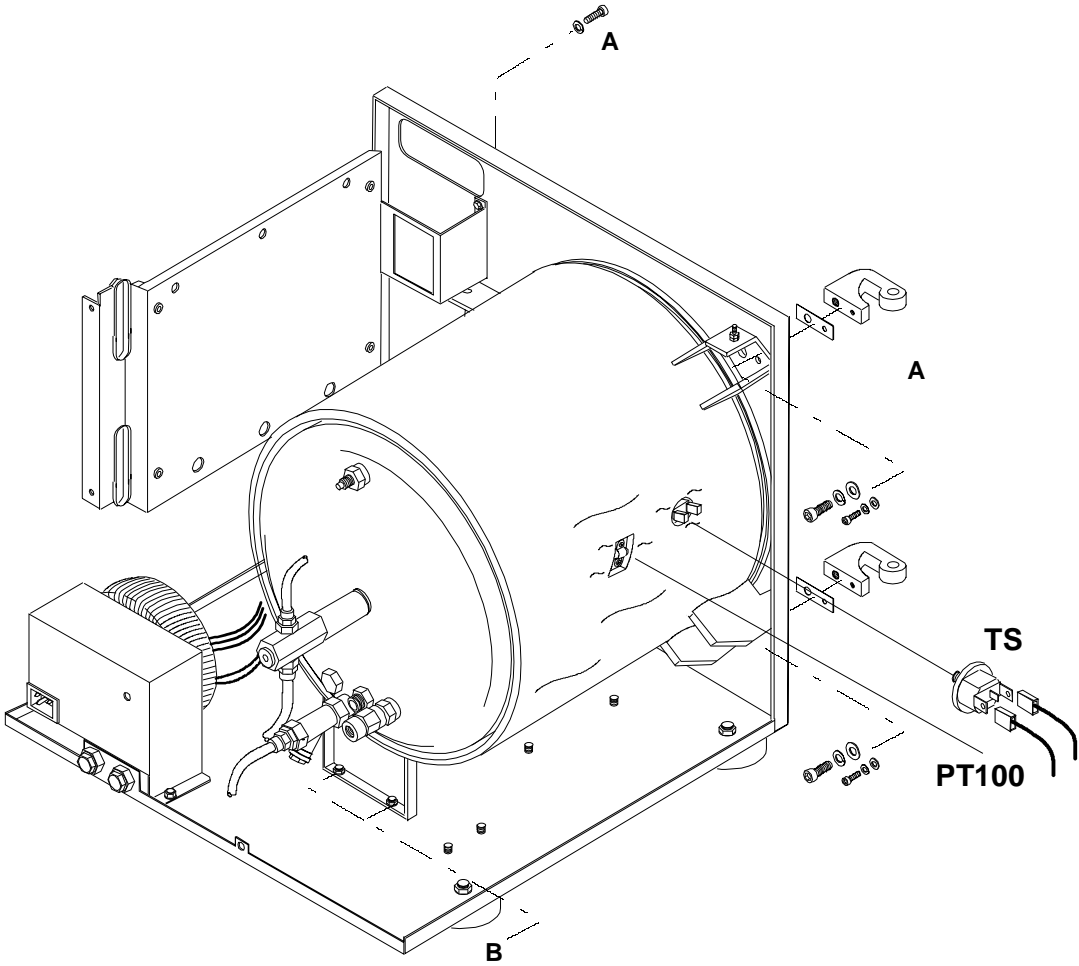

**Layout 39 – Replace Chamber Heating Element**

#	Procedures	Tools
<b>1</b>	Remove all pneumatic connections from the chamber and remove the complete rear support frame. Remove the screws securing the chamber from the frame's front side, including both door hinge mounts. Remove screw (A) from the frame front side. Remove both nuts securing base frame/chamber (B).	
 <p>The diagram is an exploded view of the sterilizer chamber assembly. It shows the chamber door on the left, the main chamber body in the center, and the base frame on the right. A heating element is mounted on the front of the chamber. Various screws and nuts are shown being removed from the assembly. Callout 'A' points to a screw on the top of the chamber. Callout 'B' points to nuts on the base frame. Callout 'TS' points to a terminal strip on the base frame. Callout 'PT100' points to a temperature sensor on the base frame. The diagram also shows the door hinge mounts and the rear support frame.</p>		

#	Procedures	Tools
2	Turn chamber upside down. Remove adhesive tape (C) and insulation jacket (D).	
3	Remove four screws securing the heating element (E). An aluminium heat sink (G) or sleeve (F) is located underneath.	5mm Allen key
4	To mount: follow the removal procedure in reverse order. Attention: The heating element fixing screws must be torqued to 2 ft.lb. (8.5 N) with a torque wrench and a 5mm Allen key.	Torque wrench

**Layout 40 – Replace Vacuum Pump Silencer**

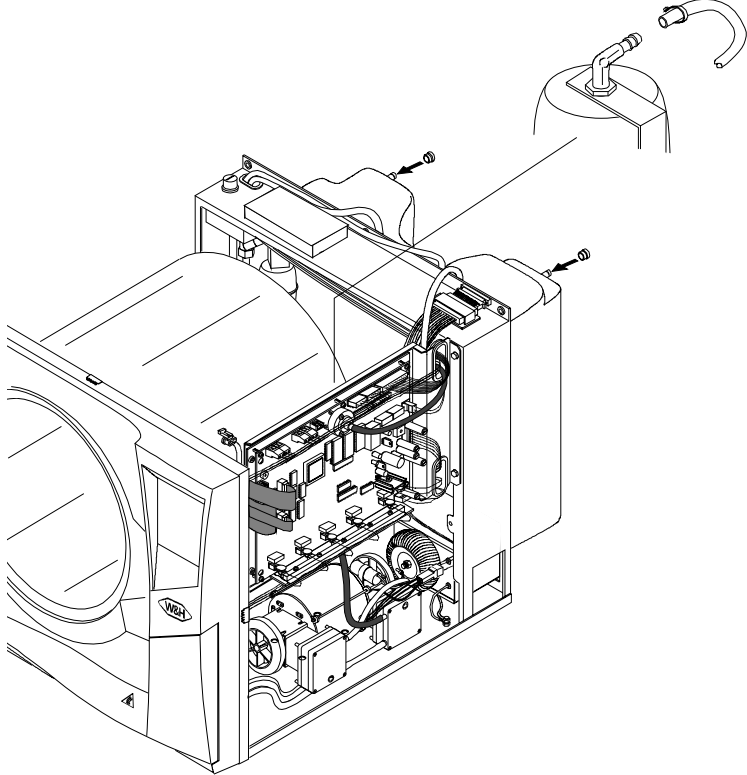
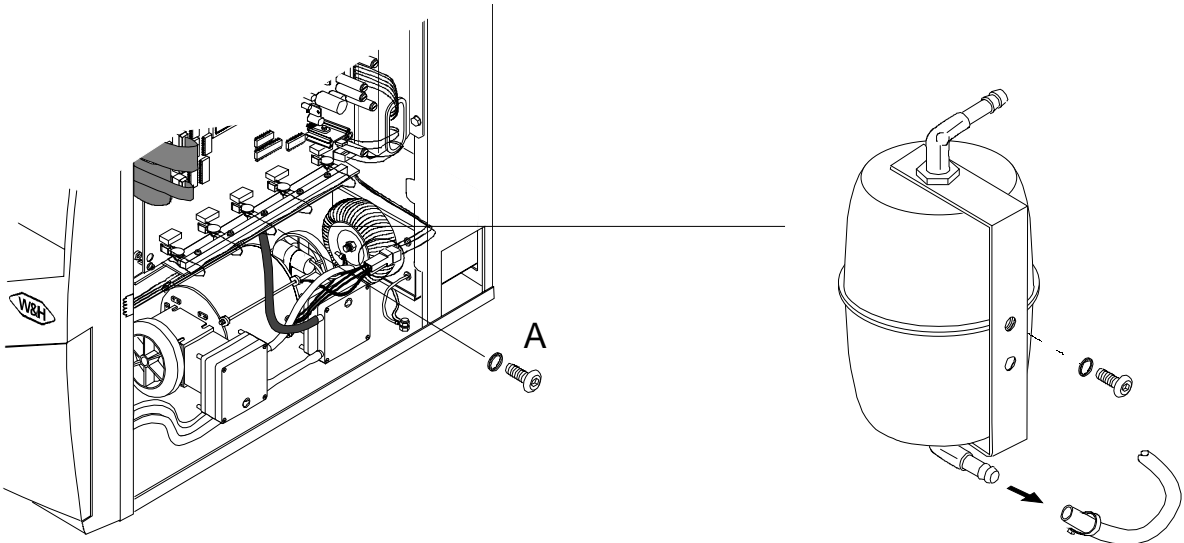
#	Procedures	Tools
<p><b>1</b></p>	<p>Remove cable tie and tubing from upper silencer inlet.</p> 	
<p><b>2</b></p>	<p>Remove the screw securing the silencer (A) from the board support plate. Remove cable tie and tubing from lower silencer outlet.</p>	
		

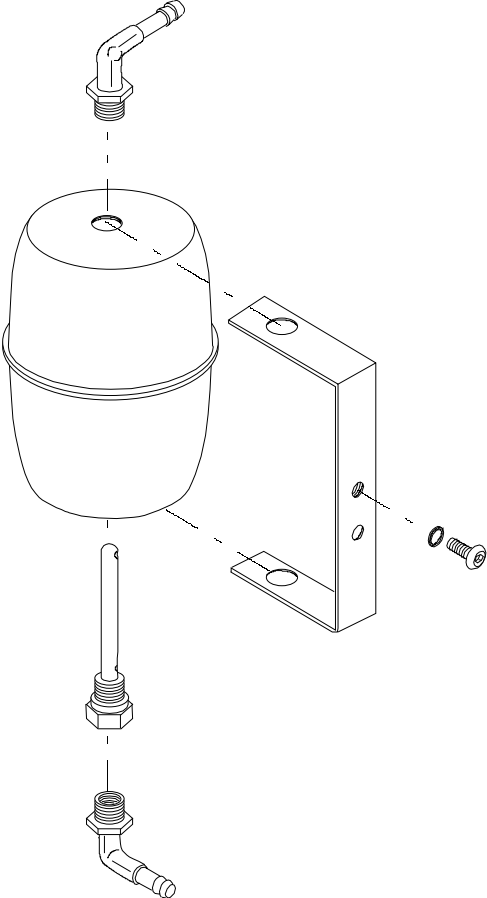
#	Procedures	Tools
<p><b>3</b></p>	<p>The exploded view of the silencer is shown below.</p> 	
<p><b>4</b></p>	<p>To mount: follow the removal procedure in reverse order.                      Attention: Use Loctite 542 on all fitting threads during reassembly.</p>	

**Layout 41 – Replace/Adjust Water Pump  
Calibrated Valve Spring**

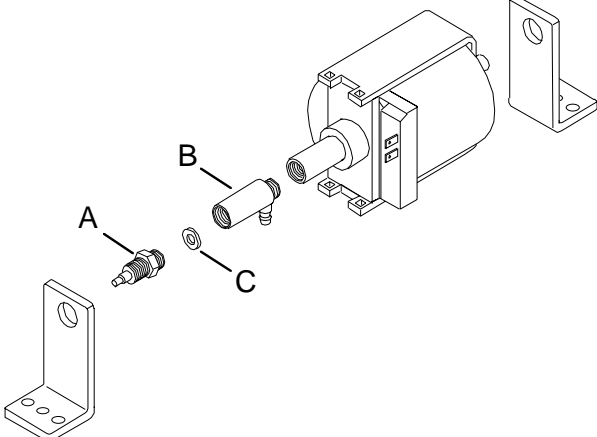
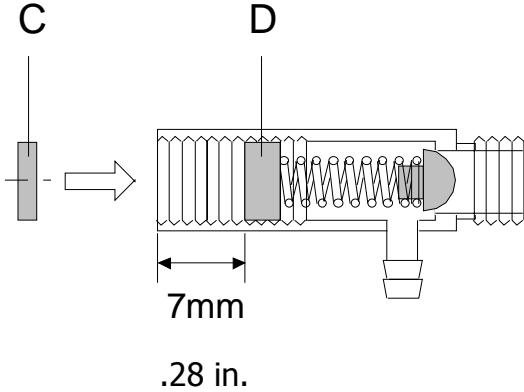
#	Procedures	Tools
<b>1</b>	<p>Remove water pump (see Layout 21) and pneumatic connections. Remove fitting (A), the one-way valve (B), and the spacer (C).</p> 	
<b>2</b>	<p>Replace valve and/or check the adjustment of nut (D) as shown. Remember to replace spacer (C).</p> 	
<b>3</b>	<p>To mount: follow the removal procedure in reverse order.</p>	

**Layout 42 – Add/Replace Composite Fascia/Cover Seal**

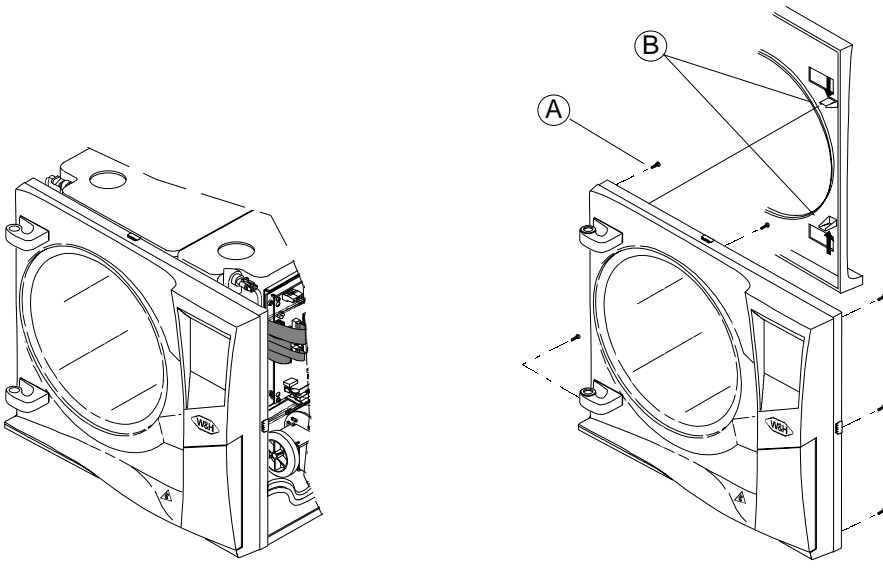
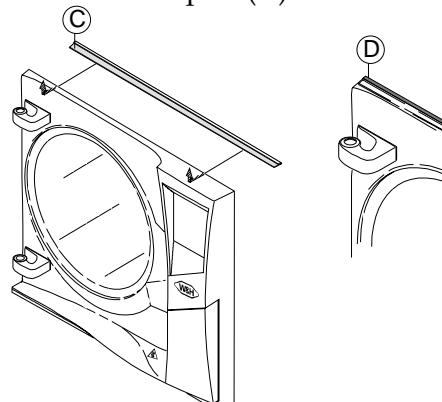
#	Procedures	Tools
<p><b>1</b></p>	<p>Remove door (see Layout 4) and screws securing composite fascia (A). Release both left side clips (B) and remove fascia as much as possible.</p>	<p>Phillips screwdriver DIN 1 (Ø 4.5) L=300mm or Torx screwdriver 10x100</p>
		
<p><b>2</b></p>	<p>Place and stick the adhesive part (C) underneath the upper composite fascia side and leave the curve part (D) free as shown.</p>	
		

**Layout 43 – Clean Chamber Outlet Filter (Filter 5)**

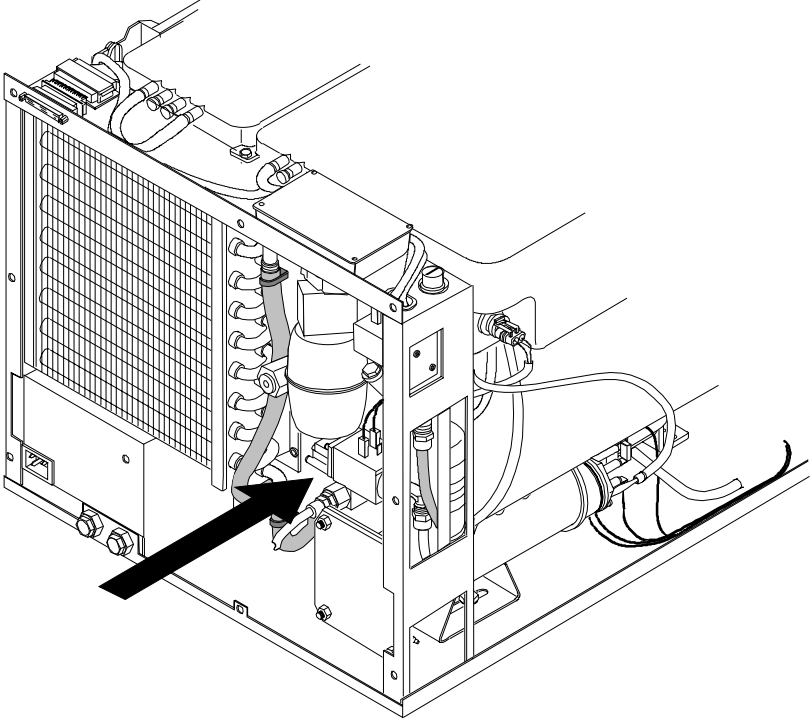
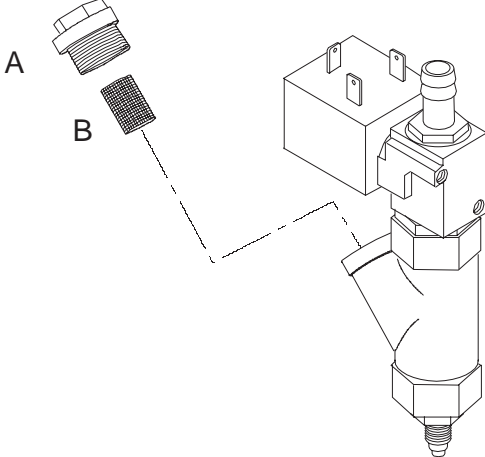
#	Procedures	Tools
<p><b>1</b></p>	<p>Remove rear holding plate to access chamber filter.</p> 	
<p><b>2</b></p>	<p>Unscrew filter seal cap (A) using 18mm spanner and remove filter (B). Clean filter with water and compressed air.</p> 	<p>18 mm spanner</p>

**Layout 44 – Clean EV5 Subset Filter (Filter 4)**

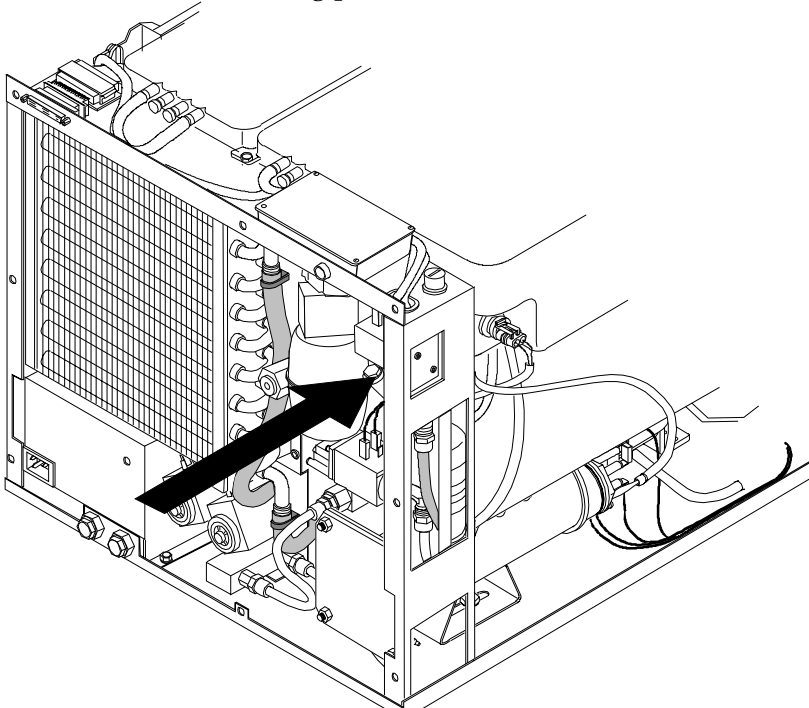
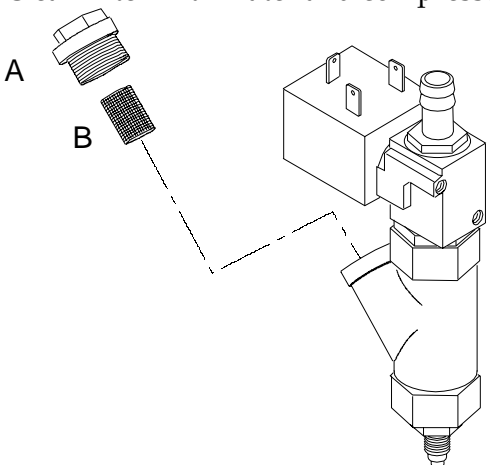
#	Procedures	Tools
<p><b>1</b></p>	<p>Remove the rear holding plate to access the EV5 subset filter.</p> 	
<p><b>2</b></p>	<p>Unscrew filter seal cap (A) using an 18mm spanner and remove filter (B). Clean filter with water and compressed air.</p> 	<p>18mm spanner</p>

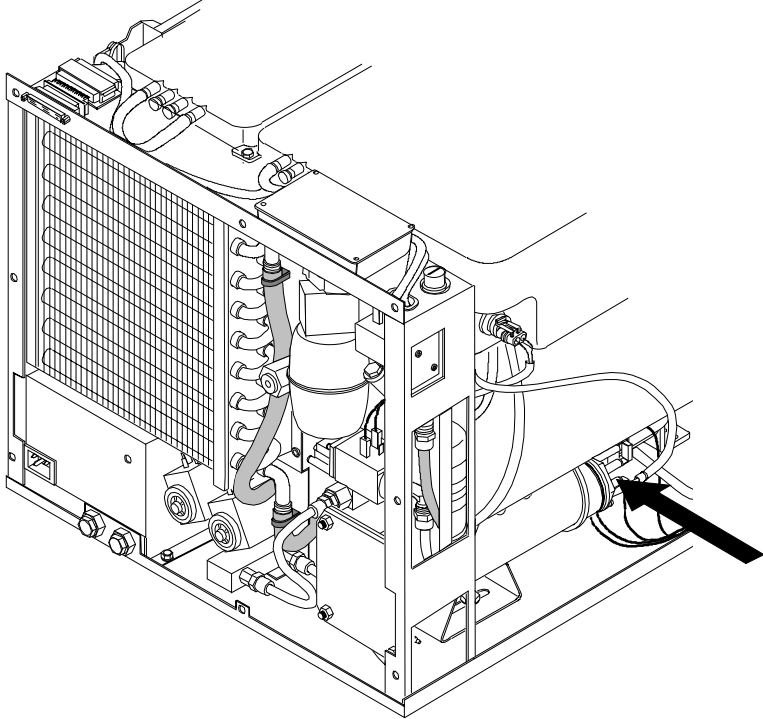
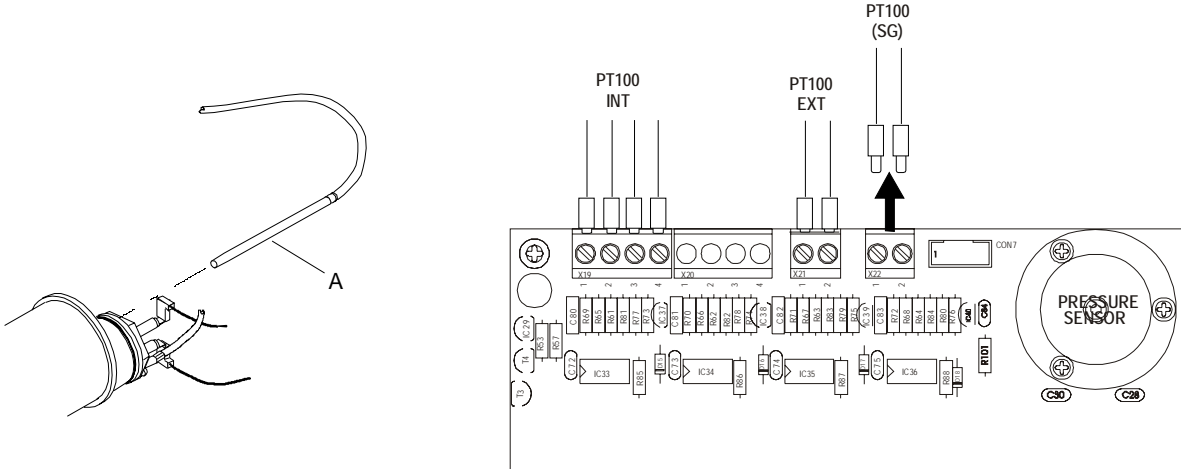

**Layout 45 – Replace Steam Generator PT100 T° Sensor**

#	Procedures	Tools
1	<p>Remove the cover.</p> 	
2	<p>Remove the holding clip and pull out the PT100 sensor A. Remove both sensor wires from the CPU board as shown.</p>	
		

**Layout 46 – Access Lisa MB17 Test Connection for Process Validation**

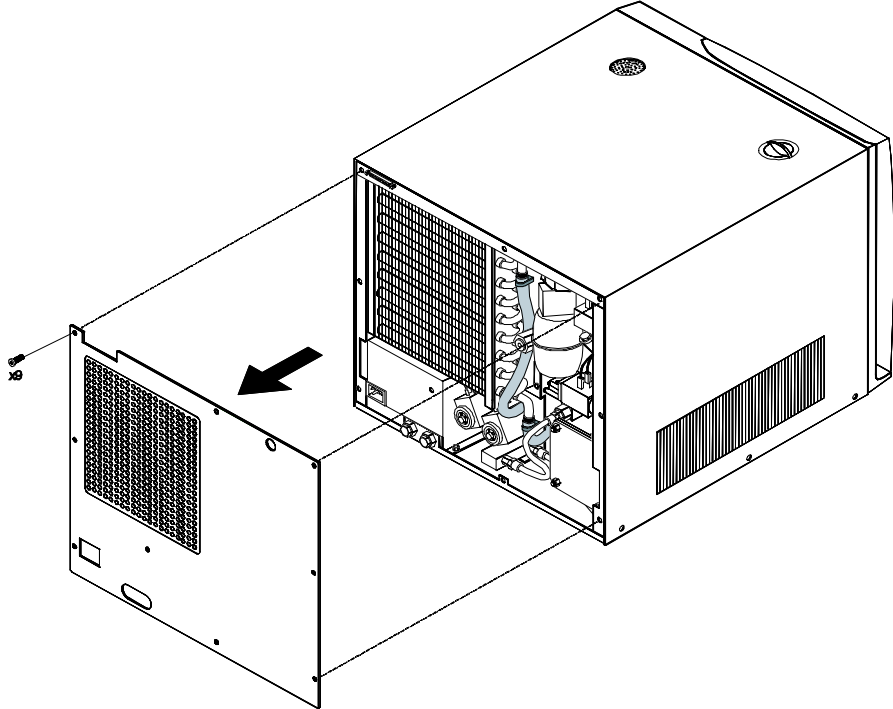
#	Procedures	Tools
<p><b>1</b></p>	<p>Remove the nine screws retaining the rear cover.</p> 	<p>Phillips screwdriver</p>
<p><b>2</b></p>	<p>Firmly hold the four-way manifold using a 22mm spanner. Unscrew the test connection sealing cap using a 6mm Allen key. Unscrew the sealing cap carefully and progressively to make sure the four-way manifold does not move.</p>	<p>22mm spanner + 6mm Allen key</p>

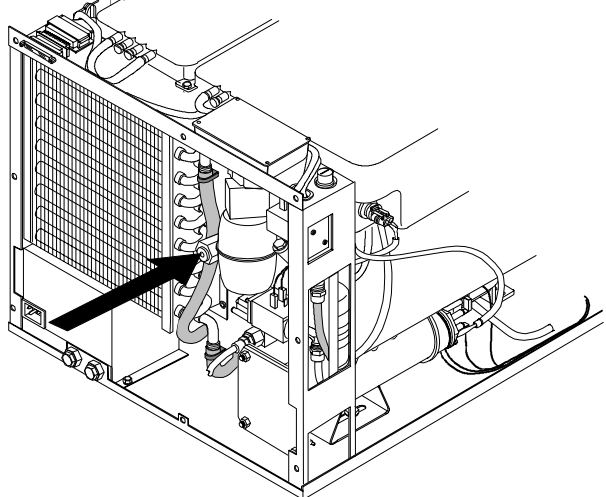
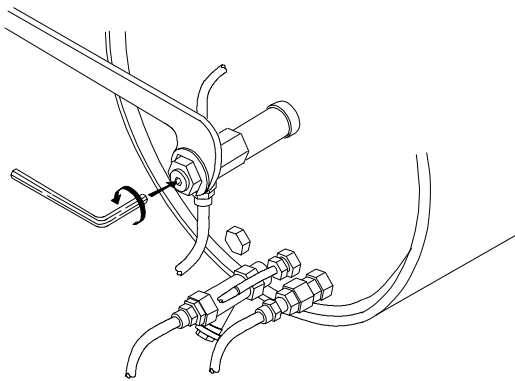
#	Procedures	Tools
<b>3</b>	Insert the external sensors in the test connection and carry out the tests. Firmly hold the four-way manifold when sealing the test connection.	22mm spanner
<b>4</b>	Check the O-ring condition. Replace if needed. Firmly hold the four-way manifold and screw (clockwise) the sealing cap.	22mm spanner  6mm Allen wrench
		
<b>5</b>	Mount the rear cover.	Phillips screwdriver

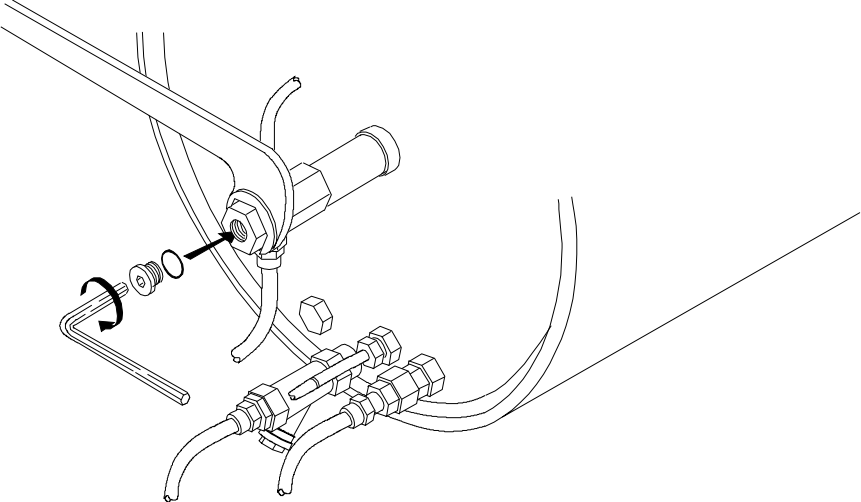
**Layout 47 – Remove/Replace Touchscreen (quick procedure)**

#	Procedures	Tools
<p><b>1</b></p>	<p>Remove printer and both touchscreen connectors from CPU board.</p> 	
<p><b>2</b></p>	<ol style="list-style-type: none"> <li>1. Open the door 90°.</li> <li>2. Remove the top screws retaining the composite fascia.</li> <li>3. Release the left side rear clip and twist the composite fascia as much as possible.</li> </ol> 	<p>DIN 1 (Ø4,5) Phillips screwdriver or 10x100 Torx screwdriver</p>
<p><b>3</b></p>	<p>Keeping the composite fascia twisted, remove the four screws and</p>	<p>DIN 1 (Ø4,5)</p>

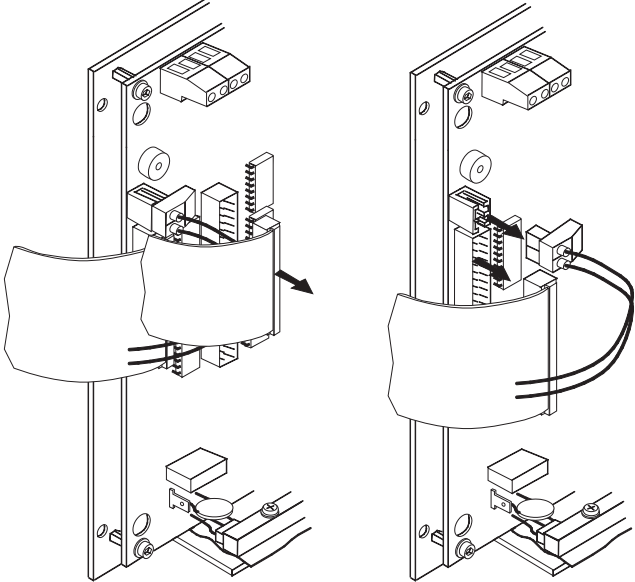
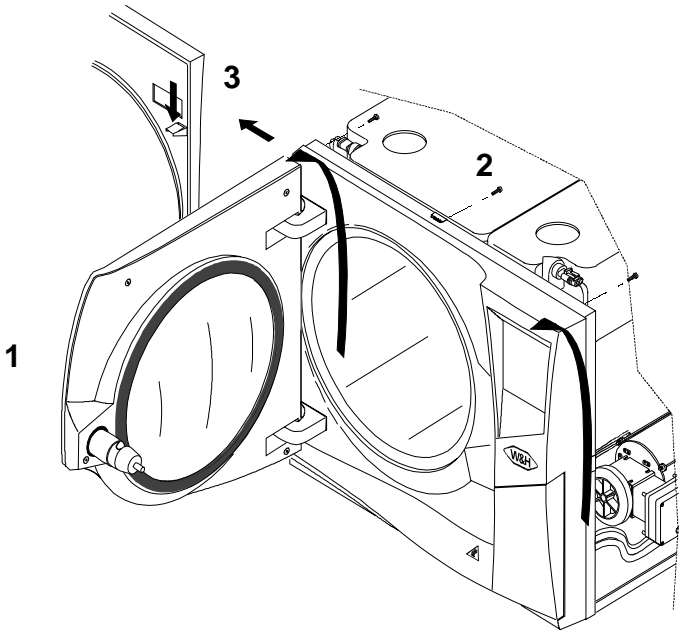
#	Procedures	Tools
	<p>corresponding white insulating washers.                      The touchscreen board mounts ESD sensitive IC's. Before handling the board, eliminate possible electrostatic charges from the body by touching an earth-connected surface.</p> 	<p>Phillips screwdriver                      or                      10x100 Torx screwdriver</p>
<p><b>4</b></p>	<p>Mount the new touchscreen protection membranes as follows:</p> <ol style="list-style-type: none"> <li>1. Remove the old protection membrane(s).</li> <li>2. Use adhesive tape to remove the scratch protection (1) from the external touchscreen membrane.</li> <li>3. Remove the adhesive protection film (2), and then place and fix the membrane on the touchscreen as shown.</li> </ol> <p>Mount the touchscreen on the composite fascia using the four screws and the corresponding white insulating washers.</p>	<p>DIN 1 (Ø4,5)                      Phillips screwdriver                      or                      10x100 Torx screwdriver</p>

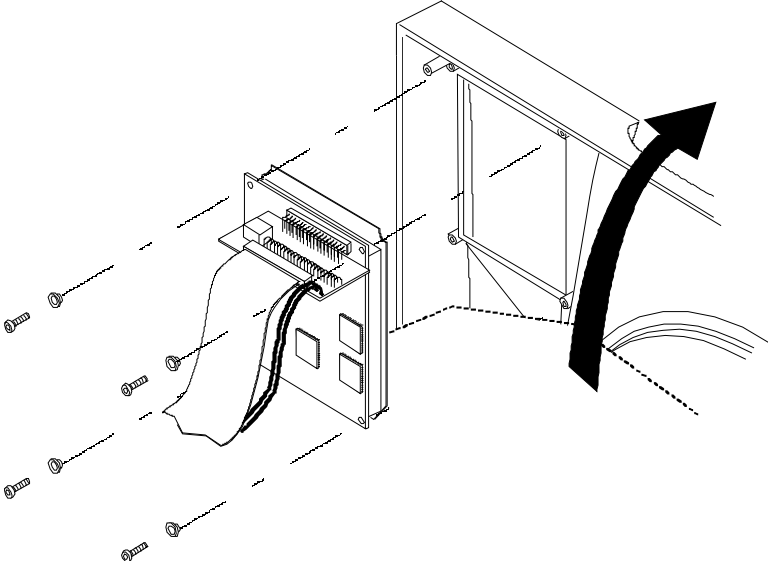

## Section 8 – Final Control

**General Controls** Use the **DIAGNOSTIC** submenu to ensure:

- ▶ the condenser fan rotates freely
- ▶ the vacuum pump and vacuum pump fans rotate freely

Check the door locking system and door locking motor consumption (See Layout 10).

**Phase Duration Check** Run a vacuum test to ensure the hydraulic circuit and the door seal are tight.

Run an empty B-STANDARD 273 cycle to check the following:

- ▶ During all cycle phases, compare phase duration to the phase duration tolerance table (below).
- ▶ Only 5 vacuum pulses should be needed (without the 6th additional pulse).
- ▶ Check to ensure the 2CS system functions properly at 23.2 and 27.5 psi (1.6 and 1.9 bar) (see description elsewhere in this section).
- ▶ Listen to ensure there is no leakage around the chamber, steam generator, or pneumatic connections. Note that the continuous steam flow between generator and chamber may be confusing.

**Phase Duration Table**

Phase	Phase Duration	Limits
PV1	4 minutes 15 seconds	< 4 minutes 45 seconds
PP1	6 seconds	< 15 seconds
PV2	35 seconds	< 1 minute
PP2	25 seconds	< 50 seconds
PV3	50 seconds	< 1 minute
PP3	6 seconds	< 15 seconds
PV4	40 seconds	< 50 seconds
PP4	25 seconds	< 40 seconds
PV5	1 minute 10 seconds	< 2 minutes
PPH	4 minutes 30 seconds	< 5 minutes 30 seconds

**Sterilization Process Check**

During the holding/plateau time (PR), check the pressure and temperature values according to the attached curve:

**Pressure:** Must stabilize at 31.2/31.3 psi (2.15/2.16 bar) except during 2CS activation: 6 seconds every 50 seconds in which period a drop of 0.5 psi (.05 bar) is normal. If this is not the case, check tightness and if necessary calibrate the CPU board (see Layout 22).

**Temperature:** Deducted from the pressure according to the saturated steam Ttheo: Temperature/Pressure Correlation table, and must read 275.7/275.9°F (135.3°C/135.5°C)(= pressure stabilized).

**Temperature:** Read (internal PT100) must stabilize between 275°F (135°C) and 277°F (136°C). Compared to Ttheo, only a maximum temperature gap of +/- 0.9°F (0.5°C) is allowed, except during 2CS activation, 6 seconds every 50 seconds in which period a drop of 0.9°F would be normal. If this is not the case, check tightness and calibrate the CPU board (see Layout 22).

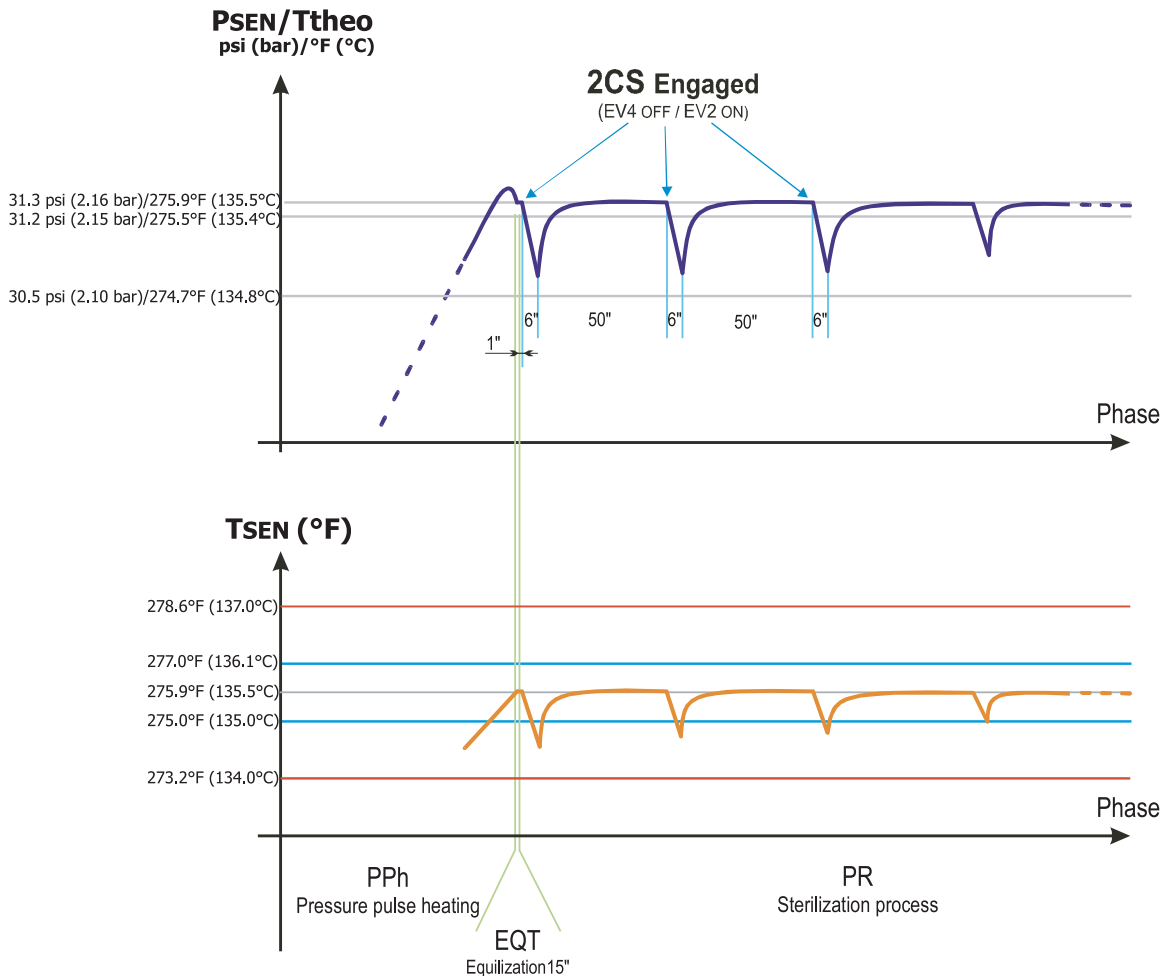



**2CS  
Condensation  
Collecting  
System**

The 2CS Condensation Collection System operates during various phases of the cycle:

- ▶ At every pre-vacuum pp/pv phase changes
- ▶ During pph ( at 10.1, 17.4, 23.2 and 27.5 psi) (0.7, 1.2, 1.6 and 1.9 bar).
- ▶ During the sterilization process (every 50 seconds).

Condensed steam continuously flows from the chamber (1, below) and is stored in the condensation collector, and returns to the steam generator (2) at the above mentioned stages to be re-vaporized.

Visually verify this condensation circulation to make sure the system works correctly. Moving fluid can be seen and checked as a result of the transparent Teflon tubing.

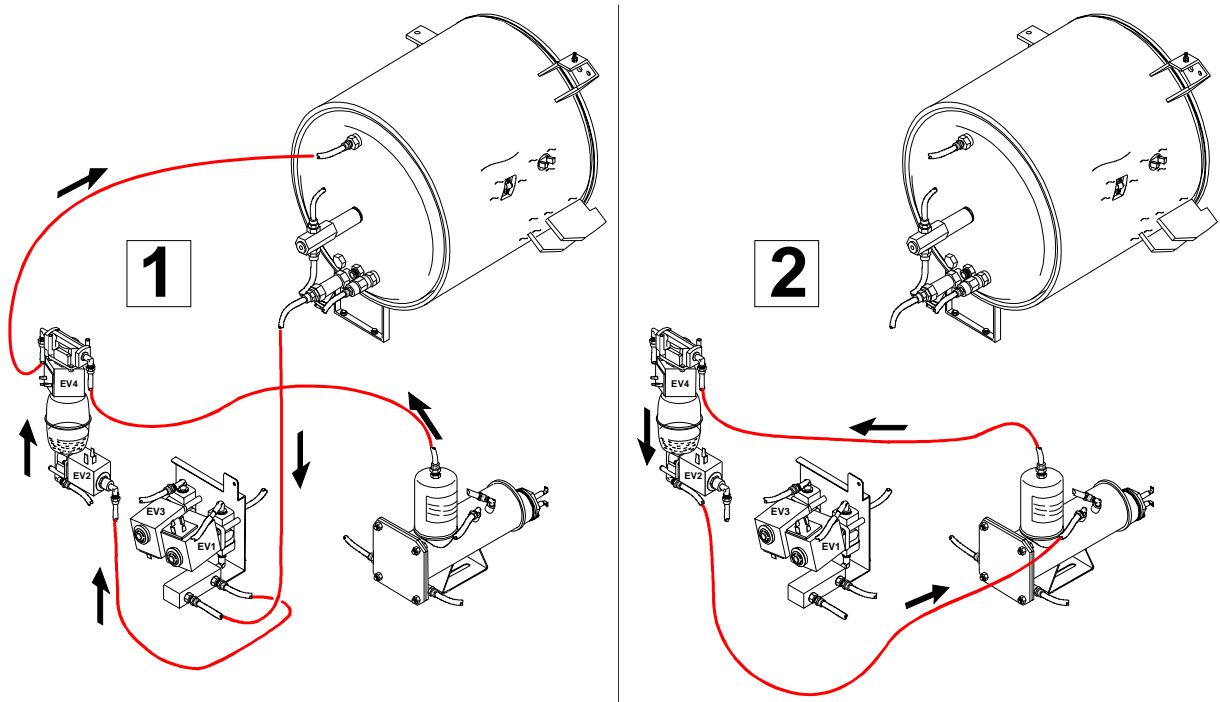

**T° / P  
Correlation  
Table**

Pressure		Calculated T°	
psi	bar	°C	°F
15.1	1.04	121.1	250.0
15.2	1.05	121.2	250.2
15.4	1.06	121.4	250.5
15.5	1.07	121.5	250.7
15.7	1.08	121.7	251.1
15.8	1.09	121.8	251.2
16.0	1.10	122.0	251.6
16.1	1.11	122.1	251.8
16.2	1.12	122.3	252.1
16.4	1.13	122.4	252.3
16.5	1.14	122.6	252.7
16.7	1.15	122.8	253.0
16.8	1.16	122.9	253.2
17.0	1.17	123.0	253.4
17.1	1.18	123.2	253.8
17.3	1.19	123.3	253.9
17.4	1.20	123.5	254.3
17.5	1.21	123.6	254.5
17.7	1.22	123.8	254.8
17.8	1.23	123.9	255.0
18.0	1.24	124.0	255.2
29.4	2.03	134.0	273.2
29.6	2.04	134.1	273.4
29.7	2.05	134.3	273.7
29.9	2.06	134.4	273.9
30.0	2.07	134.5	274.1
30.2	2.08	134.6	274.3
30.3	2.09	134.7	274.5
30.5	2.10	134.8	274.6
30.6	2.11	134.9	274.8
30.7	2.12	135.0	275.0
30.9	2.13	135.1	275.2
31.0	2.14	135.2	275.4
31.2	2.15	135.4	275.7
31.3	2.16	135.5	275.9
31.5	2.17	135.6	276.1
31.6	2.18	135.7	276.3
31.8	2.19	135.8	276.4
31.9	2.20	135.9	276.6
32.0	2.21	136.0	276.8
32.2	2.22	136.1	277.0
32.3	2.23	136.2	277.2
32.5	2.24	136.3	277.3
32.6	2.25	136.4	277.5
32.8	2.26	136.5	277.7
32.9	2.27	136.6	277.9
33.1	2.28	136.7	278.1
33.2	2.29	136.9	278.4

**Section 9 – Service Tool List**



This section lists tools required to maintain and service the Lisa sterilizer.





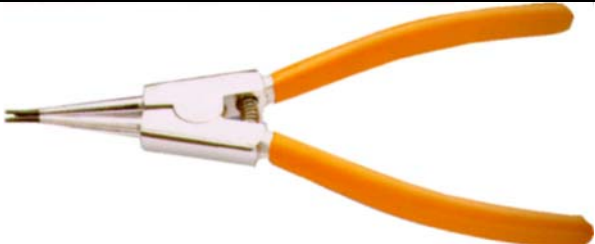

Note:

- ▶ Only use good quality tools.
- ▶ Replace any worn tools.
- ▶ Keep the tools in a suitable portable container (e.g., small suitcase).







Be careful when handling the validation electronic board; this board contains components sensitive to electrostatic discharges. After handling, return the board to its antistatic envelope.

Ref.	Description	Illustration
<p><b>1</b></p>	<p>Set of male Allen keys 2, 2.5, 3, 3.5, 4, 4.5, 5, 6, 7, 8, 9, and 10mm</p>	
<p><b>2</b></p>	<p>Set of spanners</p>	
<p><b>3</b></p>	<p>Short Phillips screwdriver 1x4, 5x30 mm</p>	
<p><b>4</b></p>	<p>Circlip pliers</p>	

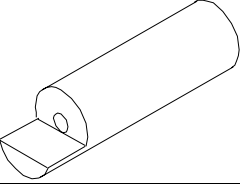
Ref.	Description	Illustration
5	Angled circlip pliers	
6	Set of straight screwdrivers	
7	Small hammer	
8	Set of Phillips screwdriver	
9	Universal forceps	
10	T-Angled ring spanner	
11	Set of Torx screwdrivers	

Ref.	Description	Illustration
12	Cutting forceps	
13	Set of ring spanners	
14	Torque wrench (from 8 to 60 Nm) + 5mm spanner 3/8"	
15	12mm special curved spanner  Part Number 54.0003.00	
16	Door locking test device (Jig)  Part Number 54.0072.00	

Ref.	Description	Illustration
17	EPROM extractor	
18	Internal chamber T° sensor PT100 positioning gauge	
19	Spanner Ø40, special for servicing the heating element of the steam generator	
20	Special tool, for blocking the steam generator during the service	
21	Anti-static grounding strap	

### **Conclusion**

Thank you for taking time to use the *Lisa Sterilizer MB17 Service Guide*. We would appreciate any feedback or comments you have about this document. Please mail, e-mail or phone us with your comments. You can reach us at:

A-dec Inc.  
Technical Communications Department  
2601 Crestview Drive  
Newberg, OR 97132

Reach us by phone at: 1.800.547.1883  
e-mail: [techcomm@a-dec.com](mailto:techcomm@a-dec.com)  
website: [www.a-dec.biz](http://www.a-dec.biz)

85.0815.00 Rev C / 2011-03  
Copyright 2011  
All rights reserved.



**A-dec® Headquarters**  
2601 Crestview Drive  
Newberg, OR 97132 USA  
Tel: 1.800.547.1883 within  
U.S.A. and Canada  
Tel: 1.503.538.7478 outside  
U.S.A. and Canada  
[www.a-dec.com](http://www.a-dec.com)

*International Distribution Centers*

**A-dec Australia**  
Tel: 1.800.225.010 Within Australia  
Tel: +61 (0)2 8332 4000 Outside Australia  
[www.a-dec.com.au](http://www.a-dec.com.au)

**A-dec United Kingdom**  
Tel: 0800 ADECUK (233285) Within UK  
Tel: +44 (0) 24 7635 0901 Outside UK  
[www.a-dec.co.uk](http://www.a-dec.co.uk)