

PRODUCT DATA

DeltaTron[®] Accelerometers

— Types 4513, 4513-001, 4513-002, 4513-B, 4513-B-001 and 4513-B-002

The wide frequency range, low noise-to-signal ratio and choice of sensitivity from 1 to 50 mV/ms⁻² (10 to 500 mV/g) means the Type 4513 range of accelerometers covers a wide range of measurement applications and can be used in a variety of environmental conditions.

FEATURES

- Insulated base
- Hermetically sealed
- High resolution
- Low noise
- Low-impedance output
- TEDS – 'B' types only

Description

The Type 4513 accelerometer family are piezoelectric Shear accelerometers with integral electronics. The transducers feature a 10–32 UNF side connector, an insulated base and are hermetically sealed. The transducers have a high resolution, giving an excellent signal-to-noise ratio. They can be mounted by means of a 10–32 UNF threaded stud, or adhesively mounted.

Characteristics

The piezoelectric accelerometers feature built-in preamplifiers. The sensitivity is expressed in terms of voltage per unit acceleration (mV/g).

In the Shear design, the piezoelectric element undergoes shear deformation as in the DeltaShear[®] design. Two rectangular slices of piezoelectric material are arranged on opposite sides of a rectangular centre post. This design gives a high degree of linearity, and excellent immunity to base bending and temperature fluctuations. The signal is collected and amplified in the built-in amplifier. The housing material is titanium.

TEDS Versions ('B' Types)

The 'B' version of each Type 4513 includes Transducer Electronic Datasheet (TEDS), containing sensor specific and application specific information, including frequency and phase response compensation. The 'B' versions are in all other aspects identical to the 'non-B' versions. The



050017

TEDS device will survive the temperature range of the accelerometer and operate in the temperature range from –40°C to +85°C.

Calibration

The transducers are individually calibrated using state-of-the-art random FFT technology, providing an 800-point high-resolution calibration (magnitude and phase), ultimately giving a unique characterisation and securing the integrity of the vibration measurement. The sensitivity given on the calibration chart has been measured at 159.2 Hz with a 95% confidence level, using a coverage factor $k = 2$.

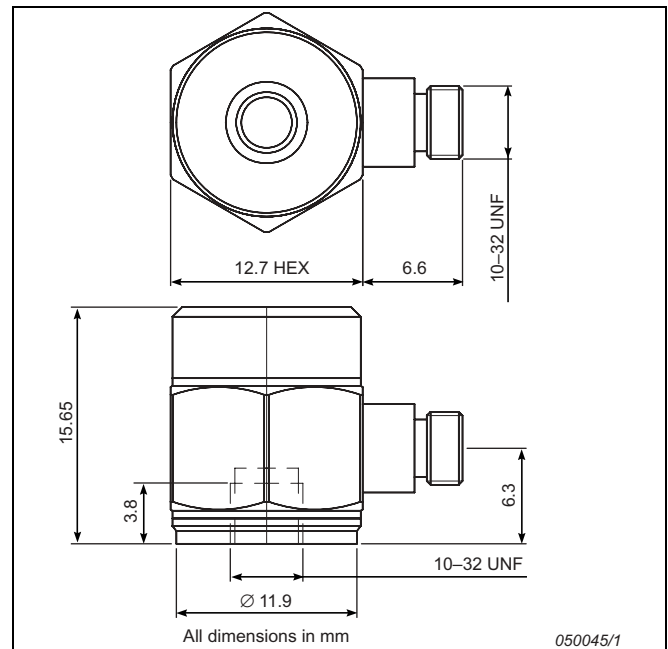

Specifications – General Purpose DeltaTron Accelerometers Types 4513(-B), 4513(-B)-001 and 4513(-B)-002

	Units	4513/ 4513-B	4513-001/ 4513-B-001	4513-002/ 4513-B-002
Dynamic Characteristics				
Voltage Sensitivity (@ 160 Hz)	mV/ms ⁻² (mV/g)	1 +12/-8% (10 ± 10%)	10 +12/-8% (100 ± 10%)	50 +12/-8% (500 ± 10%)
Measuring Range (±pk)	ms ⁻² (g)	4900 (500)	490 (50)	98 (10)
Frequency Response		See typical amplitude response		
Mounted Resonance Frequency	kHz	32		
Amplitude Response ±10% (typical) ^a	Hz	1 to 10000		
Residual Noise	mg	0.8	0.2	0.1
Transverse Sensitivity	%	<5		
Electrical Characteristics				
Output Impedance (typical)	Ω	20	100	200
DC Output At room temperature	V	12 ± 1		
Bias Voltage In specified temperature range	V	8 to 16		
Power Supply	mA	2 to 20		
Start-up Time	s	1	1	3
Grounding		Insulated base		
Environmental Characteristics				
Temperature Range	°C (°F)	-51 to +121 (-60 to +250)	-51 to +100 (-60 to +212)	-51 to +100 (-60 to +212)
Humidity		Hermetically sealed		
Max. Operational Shock (peak)	g pk	5000		
Base Strain Sensitivity	Equiv. g/μ strain	0.003		
Thermal Transient Sensitivity	Equiv. %/°C (%/°F)	0.24 (0.13)		
Thermal Shock Sensitivity	g/°C	0.04		
Physical Characteristics				
Dimensions		See outline drawing		
Weight	gram (oz.)	8.6 (0.3)		
Case Material		Titanium		
Connector		10-32 UNF		
Mounting		10-32 UNF threaded hole		
Mounting Torque	Nm (lb.in.)	1.7 (15)		

a. Individual frequency response calibration up to 10 kHz

All values are typical at 25°C (77°F) unless measurement uncertainty is specified.

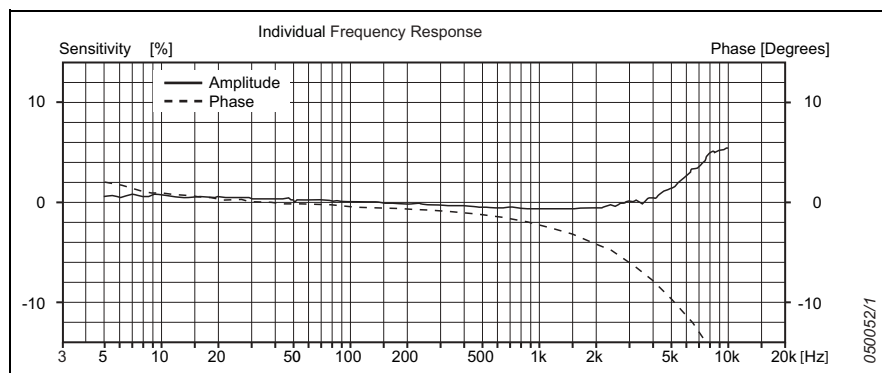

TRADEMARKS

Teflon is a registered trademark of E.I. du Pont de Nemours and Company.

Brüel & Kjær reserves the right to change specifications and accessories without notice

HEADQUARTERS: DK-2850 Nærum · Denmark · Telephone: +45 4580 0500
Fax: +45 4580 1405 · www.bksv.com · info@bksv.com

Australia (+61) 2 9889-8888 · Austria (+43) 1 865 74 00 · Brazil (+55) 11 5188-8161
Canada (+1) 514 695-8225 · China (+86) 10 680 29906 · Czech Republic (+420) 2 6702 1100
Finland (+358) 9-755 950 · France (+33) 1 69 90 71 00 · Germany (+49) 421 17 87 0
Hong Kong (+852) 2548 7486 · Hungary (+36) 1 215 83 05 · Ireland (+353) 1 807 4083
Italy (+39) 0257 68061 · Japan (+81) 3 5715 1612 · Republic of Korea (+82) 2 3473 0605
Netherlands (+31) 318 55 9290 · Norway (+47) 66 77 11 55 · Poland (+48) 22 816 75 56
Portugal (+351) 21 4169 040 · Singapore (+65) 377 4512 · Slovak Republic (+421) 25 443 0701
Spain (+34) 91 659 0820 · Sweden (+46) 33 225 622 · Switzerland (+41) 44 8807 035
Taiwan (+886) 2 2502 7255 · United Kingdom (+44) 14 38 739 000 · USA (+1) 800 332 2040

Local representatives and service organisations worldwide

COMPLIANCE WITH STANDARDS

Compliance with EMC Directive and Low Voltage Directive of the EU

Compliance with the EMC requirements of Australia and New Zealand

Ordering Information

Types 4513(-B), 4513(-B)-001 and 4513(-B)-002 include the following accessories:

- Carrying box
- Calibration chart
- 10-32 UNF Beryllium mounting stud, length 6.7 mm (0.26")
- 'B' versions include TEDS

OPTIONAL ACCESSORIES*

- AO-0038-D-012: Teflon[®] super low-noise cable, 10-32 UNF to 10-32 UNF connector 250°C (482°F), length 1.2 m (4 ft)
- AO-0531-D-050: PVC insulated flexible cable, 10-32 UNF to BNC connector 70°C (158°F), 5 m (17 ft)
- JP-0145: Plug adaptor, BNC/10-32 UNF
- UA-0186: Extension connector for 10-32 UNF cables, set of 25
- QS-0007: Tube of cyanoacrylate adhesive
- YJ-0216: Beeswax for mounting
- DB-0544: 10-32 UNF Round tip
- QA-0029: Tap for 10-32 UNF thread
- UA-0866: Cement stud 10-32 UNF 0.14 mm (0.005") (set of 25)
- UA-2064: 10-32 UNF threaded steel stud with flange, length 5.3 mm (0.2"), set of 10
- UA-2063: 10-32 UNF threaded steel studs, length 7.5 mm (0.3"), set of 10

SERVICE

- 4513-CAF: IEPE Accelerometer, Accredited Calibration
- 4513-CAI: IEPE Accelerometer, Accredited Calibration Performed as initial
- 4513-CTF: IEPE Accelerometer, Traceable Calibration
- 4513-CTI: IEPE Accelerometer, Traceable Calibration Performed as initial
- 4513-EW1: IEPE Accelerometer, Extended Warranty, one year extension

* Additional accessories and cables are available (see www.bksv.com)

Brüel & Kjær

