

FEATURES

- Three way solenoid valves with orifice and pipe connections in valve body
- Valves are designed to handle relatively high pressure 3-way applications
- Valves do not require a minimum operating pressure
- The solenoid valves satisfy all relevant EC Directives

GENERAL

Differential pressure 0 - 55 bar [1 bar = 100kPa]
Maximum viscosity 65cST (mm²/s)
Response times 5 - 25 ms

fluids (*)	temperature range (TS)	seal materials (*)
air, inert gas, water, oil	-20 to + 90°C -20 to + 40°C	NBR (nitrile) UR (urethane)

MATERIALS IN CONTACT WITH FLUID

(*) Ensure that the compatibility of the fluids in contact with the materials is verified

	Brass body	Stainless steel body
Body and seat	Brass	AISI 303 SS
Core tube	Stainless steel	Stainless steel
Core and plugnut	Stainless steel	Stainless steel
Springs	Stainless steel	Stainless steel
Sealings	NBR	NBR
Discs	NBR or UR	NBR
Disc holder & core guide	CA	CA
Shading coil	Copper	Silver

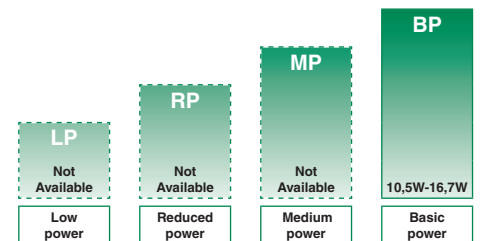
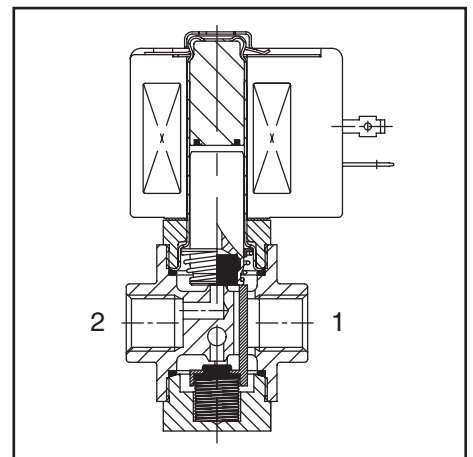

POWER LEVELS - cold electrical holding values (watt)

SPECIFICATIONS

pipe size	orifice size	flow coefficient Kv		operating pressure differential (bar)			power level BP	prefix optional solenoids					basic catalogue number		
								min.	max. (PS)		NEMA 7&9	ATEX / IECEx			IP65
				air/water(*)	~	=			EF	NF		EM	PV	SC	
NPT	(mm)	(m ³ /h)	(l/m)				~/=							brass	stainless st.
U - Universal															
1/4	0,8	0,02	0,3	0	27	19	16,7/11,2	●	●	○	●	●		B320A170 ⁽¹⁾	-
	1,6	0,08	1,3	0	9	5	10,5/11,2	●	●	●	●	●		B320A172	-
	2,4	0,10	1,7	0	7	4	16,7/11,2	●	●	○	●	●		B320B174	B320A200
NC - Normally closed															
1/4	0,8	0,02	0,3	0	50	35	16,7/11,2	●	●	○	●	●		B320A180 ⁽¹⁾	-
	1,6	0,08	1,3	0	15	11	16,7/11,2	●	●	○	●	●		B320A182	-
	2,4	0,10	1,7	0	10	8	10,5/11,2	●	●	●	●	●		B320A184	B320A202
	3,2	0,21	3,5	0	6	4	10,5/11,2	●	●	●	●	●		B320A186	B320A203
NO - Normally open															
1/4	0,8	0,02	0,3	0	55	40	16,7/11,2	●	●	○	●	●		B320A190 ⁽¹⁾	-
	1,6	0,08	1,3	0	17	11	16,7/11,2	●	●	○	●	●		B320A192	-
	2,4	0,10	1,7	0	10	7	10,5/11,2	●	●	●	●	●		B320A194	B320A204
	3,2	0,21	3,5	0	5	4	10,5/11,2	●	●	●	●	●		B320A196	B320A205

● Available feature ○ Available feature in DC only - Not available ⁽¹⁾ UR discs

PREFIX TABLE

prefix							description	power level			
1	2	3	4	5	6	7		LP	RP	MP	BP
E	F						Explosionproof - NEMA 7, 9 - Zinc plated steel conduit	-	-	-	●
E	V						Explosionproof - NEMA 7, 9 - 316 SS conduit	-	-	-	●
E	M						Waterproof IP67 - Metal enclosure (EN/IEC 60079-7+18+31)*	-	-	-	●
		E	T				Threaded conduit/hole (M20 x 1,5)	-	-	-	●
N	F						Flameproof - Aluminium (EN/IEC 60079-1, 60079-31)*	-	-	-	●
P	V						Encapsulated epoxy moulded (EN/IEC 60079-18)*	-	-	-	●
S	C						Solenoid with spade plug connector (EN/IEC 60730)	-	-	-	●
W	P						Waterproof IP67 - Metal enclosure	-	-	-	●
W	S						Waterproof IP67 - 316 SS enclosure	-	-	-	●
W	S	E	M				Waterproof IP67 - 316 SS enclosure (EN/IEC 60079-7+18+31)*	-	-	-	●
W	S	N	F				Flameproof - 316L SS (EN/IEC 60079-1, 60079-31)*	-	-	-	●
							Threaded conduit (1/2" NPT)	-	-	-	●
				H	C		Class H - Battery charging circuit	-	-	-	●
				H	T		Class H - High temperature	-	-	-	●
						X	Other special constructions	-	-	-	●

SUFFIX TABLE

suffix					description	power level			
1	2	3	4	5		LP	RP	MP	BP
E					EPDM (ethylene-propylene)	-	-	-	●
J					CR (chloroprene)	-	-	-	●
N					Oxygen service (CR (chloroprene))	-	-	-	●
N	V				FPM (fluoroelastomer) and parts cleaned for oxygen service	-	-	-	●
T					PTFE (polytetrafluoroethylene)	-	-	-	●
V					FPM (fluoroelastomer)	-	-	-	●
W					UR (urethane)	-	-	-	◆
	C	O			Epoxy coating on all external surfaces	-	-	-	●
	M	B			Mounting bracket	-	-	-	●
		P			Dry gas, non-lubricated air construction	-	-	-	●
		Q			Long life, quiet operation construction	-	-	-	●
			M	O	Push type manual operator	-	-	-	●
			M	S	Screw type manual operator	-	-	-	●

- Available feature
- ◆ Standard feature for B320A170, B320A180 and B320A190
- Not available
- * ATEX/IECEx valves using these solenoids are approved according to EN 13463-1 (non electrical)

PRODUCT SELECTION GUIDE

STEP 1

Select basic catalogue number, including pipe thread identification letter. Refer to the specifications table on page 1.

Example: B320A202

STEP 2

Select prefix (combination). Refer to the specifications table on page 1 and the prefix table on page 2, respect the indicated power level.

Example: PV

STEP 3

Select suffix (combination) if required. Refer to the suffix table on page 2, respect the indicated power level.

Example: T

STEP 4

Select voltage. Refer to standard voltages on page 3.

Example: 24V / DC

STEP 5

Final catalogue / ordering number.

Example:

PVB320A202 T 24V / DC

OPTIONS & ACCESSORIES

catalogue number	spare parts kit no. ⁽¹⁾		mounting bracket no.
	~	=	
SC B 320A170	C302112	C302200	160800 ⁽²⁾
SC B 320A172	C302114	C302201	160800 ⁽²⁾
SC B 320B174	C302116	C302201	160800 ⁽²⁾
SC B 320A180	C302140	C302226	160800 ⁽²⁾
SC B 320A182	C302141	C302227	160800 ⁽²⁾
SC B 320A184	C302142	C302227	160800 ⁽²⁾
SC B 320A186	C302143	C302228	160800 ⁽²⁾
SC B 320A190	C302182	C302254	160800 ⁽²⁾
SC B 320A192	C302183	C302255	160800 ⁽²⁾
SC B 320A194	C302184	C302255	160800 ⁽²⁾
SC B 320A196	C302184	C302255	160800 ⁽²⁾
SC B 320A200	C312189	C312190	162950-001 ⁽³⁾
SC B 320A202	C312191	C312192	162950-001 ⁽³⁾
SC B 320A203	C312191	C312192	162950-001 ⁽³⁾
SC B 320A204	C312193	C312194	162950-001 ⁽³⁾
SC B 320A205	C312193	C312194	162950-001 ⁽³⁾

- ⁽¹⁾ Standard prefixes/suffixes are also applicable to kits
- ⁽²⁾ Mounting holes in body
- ⁽³⁾ Mounting bracket supplied standard with valve

ORDERING EXAMPLES VALVES:

WST	B	320A192		230V / 50 Hz
SCHT	B	320A184	V	230V / 50 Hz
SC	B	320A194	MB	24V / DC
WP	B	320A170	MS	24V / DC
WS	B	320A182	VP	24V / DC
	B	320B174	Q	230V / 50 Hz
	B	320A190	CO	230V / 50 Hz
EF	B	320G200	MO	240V / 60 Hz

prefix ⁽⁴⁾ pipe thread basic number ⁽⁴⁾ voltage suffix

ORDERING EXAMPLES KITS:

WSEM	C302183
	C302142 V ⁽⁵⁾
	C302255 MO ⁽⁵⁾
WP	C302200 MS

prefix basic number suffix

- ⁽⁴⁾ Prefix EF and EV should always be used in conjunction with change letter G in the basic number
- ⁽⁵⁾ Basic kit number applies to SC coil construction

EXPLANATION OF TEMPERATURE RANGES OF SOLENOID VALVES

- Valve temperature range The valve temperature range (TS) is determined by the selected seal material, the temperature range for proper operation of the valve and sometimes by the fluid (e.g. steam)
- Operator ambient temperature range The operator ambient temperature range is determined by the selected power level and the safety code
- Total temperature range The temperature range of the complete solenoid valve is determined by the limitations of both temperature ranges above

ELECTRICAL CHARACTERISTICS

- Coil insulation class F
- Electrical safety IEC 335
- Standard voltages DC (=) 24V - 48V
AC (~) 24V - 48V - 115V - 230V/50Hz; other voltages and 60Hz are available on request

prefix option	power ratings				operator ambient temperature range (C°) ⁽¹⁾	safety code	electrical enclosure protection (EN 60529)	replacement coil / kit		type ⁽²⁾
	inrush ~	holding ~		hot/cold =				~	=	
	(VA)	(VA)	(W)	(W)				230V/50 Hz	24V/DC	
Basic power (BP)										
SC	55,0	23,0	10,5	9,0/11,2	-40 to +75	EN 60730	IP65, moulded	400425-117	400425-142	01-02
SC	78,0	35,0	16,7	-	-40 to +50	EN 60730	IP65, moulded	400425-217	-	01-02
WP/WS	55,0	23,0	10,5	9,0/11,2	-40 to +75	EN 60730	IP67, steel/SS	400405-117	400405-142	03-04
WP/WS	78,0	35,0	16,7	-	-40 to +50	EN 60730	IP67, steel/SS	400405-217	-	03-04
NF/WSNF	55,0	23,0	10,5	-	-60 to +25/40/60	II2G Ex d IIC Gb T6/T5/T4, II2D Ex tb IIIC Db	IP66/67, alu./SS	400405-117	-	05-06
NF/WSNF	-	-	-	9,0/11,2	-60 to +40/60/75	II2G Ex d IIC Gb T6/T5/T4, II2D Ex tb IIIC Db	IP66/67, alu./SS	-	400405-142	05-06
NF/WSNF	78,0	35,0	16,7	-	-60 to +40	II2G Ex d IIC Gb T4, II2D Ex tb IIIC Db	IP66/67, alu./SS	400405-217	-	05-06
EM/WSEM	55,0	23,0	10,5	9,0/11,2	-40 to +40	II2G Ex e mb IIC Gb T3, II2D Ex tb IIIC Db	IP66/67, steel/SS	400909-117	400913-142	03-04
PV	55,0	23,0	10,5	9,0/11,2	-40 to +65	II2G/D Ex mb IIC Gb T3(~)/T4(=), Ex mb IIIC Db	IP67, moulded	- ⁽³⁾	- ⁽³⁾	07-08
EF	50,0	25,0	10,1	9,0/11,6	-40 to +52/40	NEMA type 7 and 9	NEMA 4X	238614-057D	238714-006D	09-10
EF	70,0	40,0	17,1	-	-40 to +52	NEMA type 7 and 9	NEMA 4X	238614-157D	-	09-10

⁽¹⁾ Temperature range can be limited by sealings ⁽³⁾ Multiple coil kits are available under ATEX/IECEX, contact us
⁽²⁾ Refer to the dimensional drawings on pages 4 to 5 - Not available

ELECTRICAL CONNECTIONS

prefix	connection
SC,	Spade plug connector with cable gland EN175301-803A (ISO 4400) for cables with an outer diameter from 6 to 10 mm.
WP, WS, EM, WSEM	M22 cable gland for cables with an outer diameter from 7 to 12 mm. With an internal and external facility for an earthing or bonding conductor.
NF, WSNF	1/2" NPT threaded cable entry. Enclosures are supplied without cable gland.
PV	Moulded-in cable, standard length 2 m

ADDITIONAL OPTIONS

- Ex mb (prefix "PV") execution can be supplied in various cable lengths
- Compliance with "UL", "CSA" and other local approvals available on request
- 1/2" NPT (prefix "T") and M20 x 1,5 (prefix "ET") conduits (aluminium or 316 SS) available for steel solenoid housing
- Special moulded-in solid state components for peak voltage suppression and/or rectification (four diode bridge)
- Mounting brackets for brass body valves, suffix MB

INSTALLATION

- Multi language installation/maintenance instructions are included with each valve
- The solenoid valves can be mounted in any position without affecting operation
- Stainless steel valves are standard supplied with mounting brackets
- Threaded pipe connection identifier is B = NPT (ANSI 1.20.3)
- Declarations of conformity are available on request

DIMENSIONS (mm), WEIGHT (kg)



TYPE 01:
Epoxy moulded
SC: IEC 335 / ISO 4400

B320A170 / A172 / B174 / A180 / A182 / A184 /
B320A186 / A190 / A192 / A194 / A196

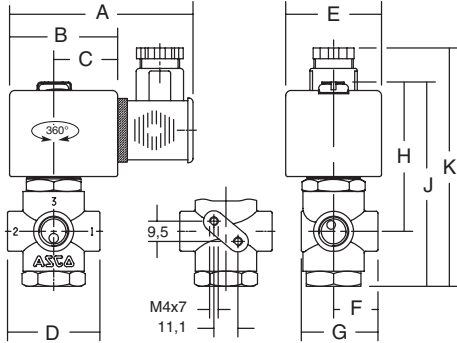

TYPE 02:
Epoxy moulded
SC: IEC 335 / ISO 4400

B320A200 / A202 / A203 / A204 / A205

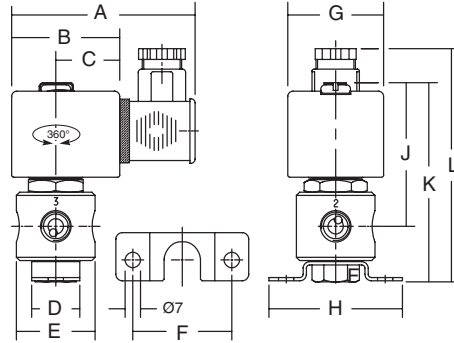

TYPE 03:
Metal, epoxy coated / AISI 316 SS
WP / WS: IEC 335
EM / WSEM: EN 60079-7, -18 and -31

B320A170 / A172 / B174 / A180 / A182 / A184 /
B320A186 / A190 / A192 / A194 / A196

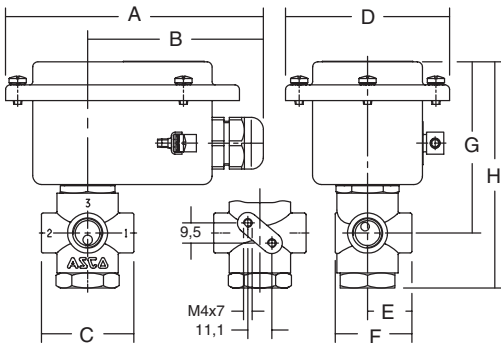

TYPE 04:
Metal, epoxy coated / AISI 316 SS
WP / WS: IEC 335
EM / WSEM: EN 60079-7, -18 and -31

B320A200 / A202 / A203 / A204 / A205

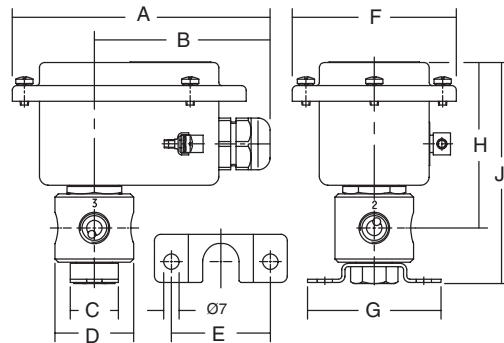

TYPE 05:
Aluminium, epoxy coated / AISI 316L SS
NF / WSNF: EN/IEC 60079-1 and EN/IEC 60079-31

B320A170 / A172 / B174 / A180 / A182 / A184 /
B320A186 / A190 / A192 / A194 / A196

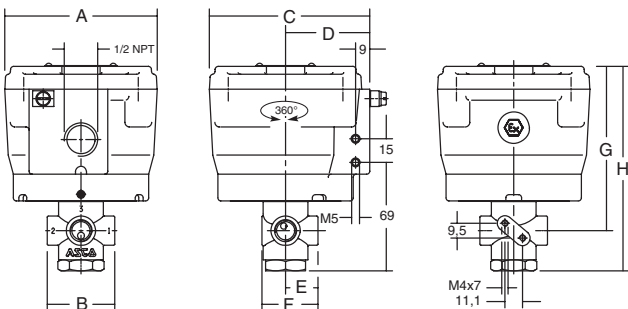

TYPE 06:
Aluminium, epoxy coated / AISI 316L SS
NF / WSNF: EN/IEC 60079-1 and EN/IEC 60079-31

B320A200 / A202 / A203 / A204 / A205

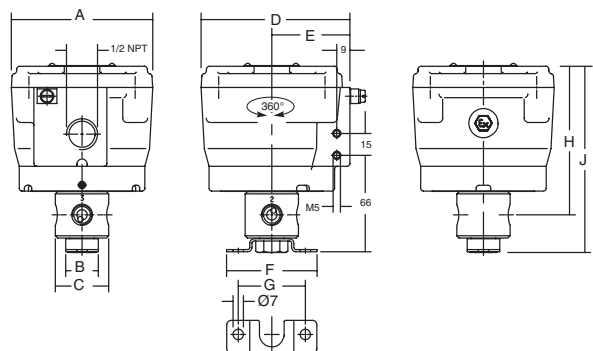

DIMENSIONS (mm), WEIGHT (kg)



TYPE 07:
Epoxy encapsulated
PV: EN/IEC 60079-18

B320A170 / A172 / B174 / A180 / A182 / A184 /
B320A186 / A190 / A192 / A194 / A196

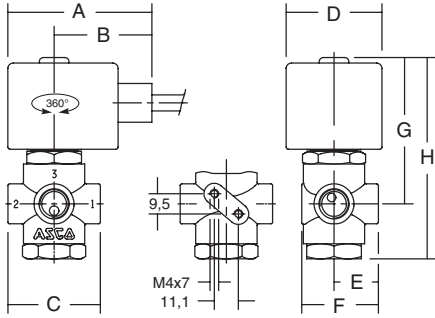

TYPE 08:
Epoxy encapsulated
PV: EN/IEC 60079-18

B320A200 / A202 / A203 / A204 / A205

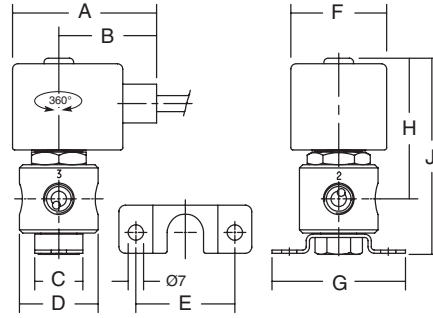

TYPE 09:
Epoxy encapsulated
EF: ICS-6 ANSI / NEMA Type 7 and 9
NOTE: applicable to solenoid only

B320G170 / G172 / G174 / G180 / G182 / G184 /
B320G186 / G190 / G192 / G194 / G196

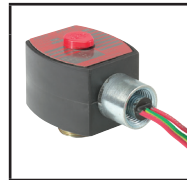
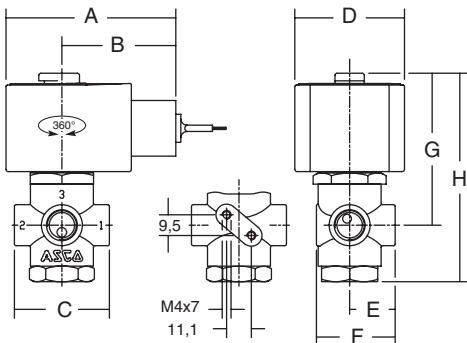

TYPE 10:
Epoxy encapsulated
EF: ICS-6 ANSI / NEMA Type 7 and 9
NOTE: applicable to solenoid only

B320G200 / G202 / G203 / G204 / G205

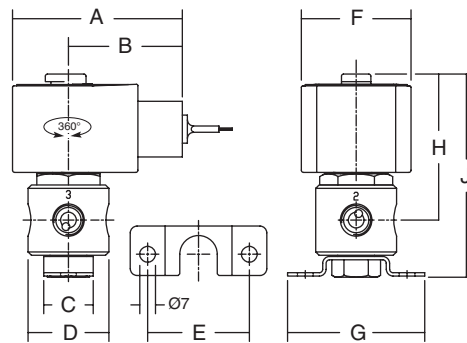

type	prefix/option	power level	A	B	C	D	E	F	G	H	J	K	L	weight
01	SC	BP	80	50	30	43	45	21	36	70	95	108	-	0,55 kg
02	SC	BP	80	50	30	22	40	46	45	62	69	94	107	0,55 kg
03	WP, WS, EM/WSEM	BP	120	82	43	77	21	36	79	105	-	-	-	0,60 kg
04	WP, WS, EM/WSEM	BP	120	82	22	36	46	77	62	77	103	-	-	0,70 kg
05	NF/WSNF	BP	97	73	103	54	21	36	104	130	-	-	-	1,60 kg
06	NF/WSNF	BP	97	22	36	102	54	62	46	102	128	-	-	1,75 kg
07	PV	BP	67	45	43	45	21	36	63	94	-	-	-	0,60 kg
08	PV	BP	67	45	22	36	46	45	62	65	91	-	-	0,70 kg
09	EF	BP	77	51	43	50	21	36	69	94	-	-	-	0,70 kg
10	EF	BP	77	51	22	37	46	50	62	66	92	-	-	0,70 kg

MOUNTING BRACKETS

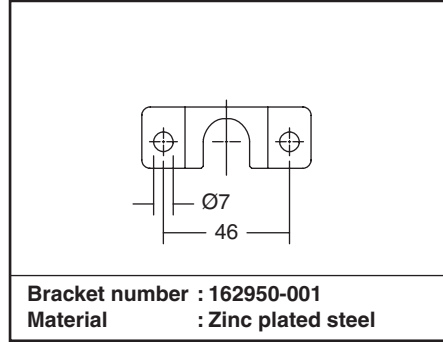
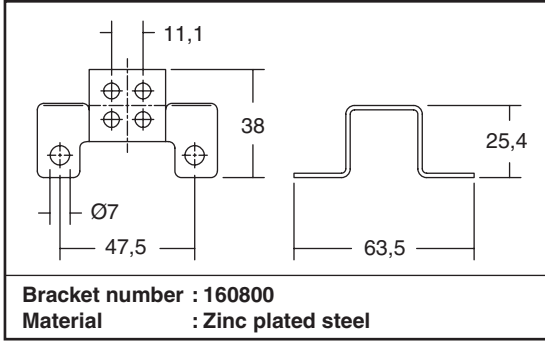

SECTIONAL DRAWING

