



BMW Motorrad

bmw-motorrad.com



The Ultimate
Riding Machine

Rider's Manual

G310R

Vehicle data/dealership details

Vehicle data

Model

Vehicle Identification Number

Colour code

Date of first registration

Registration number

Dealership details

Person to contact in Service department

Ms/Mr

Phone number

Dealership address/phone number (company stamp)

Welcome to BMW

We congratulate you on your choice of a vehicle from BMW Motorrad and welcome you to the community of BMW riders. Familiarise yourself with your new vehicle so that you can ride it safely and confidently in all traffic situations.

About this Rider's Manual

Please read this Rider's Manual carefully before starting to use your new BMW. It contains important information on how to operate the controls and how to make the best possible use of all your BMW's technical features. In addition, it contains information on maintenance and care to help you maintain your vehicle's reliability and safety, as well as its value.

This record of the maintenance work you have had performed on

your vehicle is a precondition for generous treatment of goodwill claims.

If the time comes to sell your BMW, please remember to hand over this Rider's Manual to the new owner. It is an important part of the vehicle.

Suggestions and criticism

If you have questions concerning your vehicle, your authorised BMW Motorrad dealer will gladly provide advice and assistance.

We hope you will enjoy riding your BMW and that all your journeys will be pleasant and safe

BMW Motorrad.

01 40 8 392 971



Table of Contents

1 General instructions 5	Engine speed display 30	Refuelling 54
Quick & easy reference 6	4 Operation..... 31	Securing motorcycle for transportation 56
Abbreviations and symbols 6	Ignition 32	7 Engineering details..... 59
Equipment 7	Lights 34	General instructions 60
Technical data 7	Turn indicators 34	Anti-lock brake system 60
Actuality 7	Multifunction display 36	8 Maintenance 63
2 General views 9	Date and time 37	General instructions 64
General view, left side 11	Reset the trip distance 37	Toolkit..... 64
General view, right side 13	Resetting the average values 38	Front-wheel stand..... 65
Underneath the seat 14	Seat 38	Rear-wheel stand 66
Multifunction switch, left 15	5 Adjustment..... 41	Engine oil 67
Multifunction switch, right 16	Mirrors 42	Brake system 68
Instrument panel 17	Headlight..... 42	Clutch 73
3 Status indicators 19	Spring preload 44	Coolant..... 74
Warning and telltale lights 20	6 Riding..... 45	Wheel rims and tyres..... 75
Multifunction display 21	Safety instructions 46	Wheels 76
Warnings 22	Checklist 48	Chain..... 84
Service-due indicator 28	Starting..... 48	Light source..... 86
Fuel reserve..... 29	Running in 51	Jump-starting 90
	rpm redline warning 52	Battery 91
	Brakes 52	Fuses 94
	Parking your motorcycle 53	Diagnostic connector..... 96

9 Accessories	99	Engine	116
General instructions	100	Clutch	117
Heated handlebar grips ...	100	Transmission	117
Power socket	101	Rear-wheel drive	118
Topcase.....	101	Frame	118
TopcaseLight	104	Chassis and suspension	119
Maximum payload and maximum permissible speed	105	Brakes	119
10 Care	107	Wheels and tyres.....	120
Care products.....	108	Electrical system	122
Washing the vehicle	108	Dimensions	123
Cleaning easily damaged components.....	109	Weights	124
Paint	110	Riding specifications	124
Preserving paintwork	110	Accessories	124
Laying up the motor- cycle	110	12 Service	125
Restoring motorcycle to use	110	BMW Motorrad Service ...	126
11 Technical data	111	BMW Motorrad Mobility services	126
Troubleshooting chart.....	112	Maintenance work.....	126
Screw connections	113	Maintenance schedule ...	129
Fuel	115	Confirmation of mainten- ance work	130
Engine oil	115	Confirmation of service ...	144
		13 Index	146

General instructions

Quick & easy reference	6
Abbreviations and symbols	6
Equipment	7
Technical data	7
Actuality	7

Quick & easy reference

An important aspect of this Rider's Manual is that it can be used for quick and easy reference. Go straight to the "General views" chapter if you would like an initial overview of your motorcycle.

Abbreviations and symbols



CAUTION Low-risk hazard. Non-avoidance can lead to slight or moderate injury.



WARNING Medium-risk hazard. Non-avoidance can lead to fatal or severe injury.



DANGER High-risk hazard. Non-avoidance leads to fatal or severe injury.



ATTENTION Special notes and precautionary measures. Non-compliance can lead to damage to the vehicle or

accessory and, consequently, to voiding of the warranty.



NOTICE Specific instructions on how to operate, control, adjust or look after items of equipment on the vehicle.



Indicates the end of an item of information.



Instruction.



Result of an activity.



Reference to a page with more detailed information.



Indicates the end of a passage relating to specific accessories or items of equipment.



Tightening torque.



Technical data.

ABS

Anti-lock brake system.

National-

National-market version.

market
version

OA

Optional accessories. You can obtain BMW Motorrad optional accessories through your authorised BMW Motorrad dealer; optional accessories have to be retrofitted to the vehicle.

Equipment

When you purchased your BMW motorcycle, you chose a model with individual equipment. This Rider's Manual describes selected optional accessories (OA) from BMW. This explains why the manual may also contain descriptions of equipment which you have not ordered. Please note, too, that your motorcycle might not be exactly as illustrated in this manual on account of country-specific differences. If your motorcycle contains equipment that has not been described, its description can be found in a separate manual.

Technical data

All dimensions, weights and power ratings stated in the Rider's Manual are quoted to the standards and comply with the tolerance requirements of the

Deutsches Institut für Normung e. V. (DIN). Versions for individual countries may differ.

Actuality

The high safety and quality level of BMW motorcycles is ensured by continuous development work on design, equipment and accessories. Because of this, your motorcycle may differ from the information supplied in the Rider's Manual. Nor can BMW Motorrad entirely rule out errors and omissions. We hope you will appreciate that no claims can be entertained on the basis of the data, illustrations or descriptions in this manual.

General views

General view, left side.....	11
General view, right side	13
Underneath the seat	14
Multifunction switch, left	15
Multifunction switch, right.....	16
Instrument panel	17



General view, left side

- 1 – with extra socket^{OA}
Power socket (➡ 101)
- 2 Adjusting ring for spring
preload (➡ 44)
- 3 Seat lock (➡ 38)
- 4 Chain settings (➡ 84)
- 5 Engine oil level indicator
(➡ 67)
- 6 Type plate
- 7 Table of tyre pressures
(➡ 76)

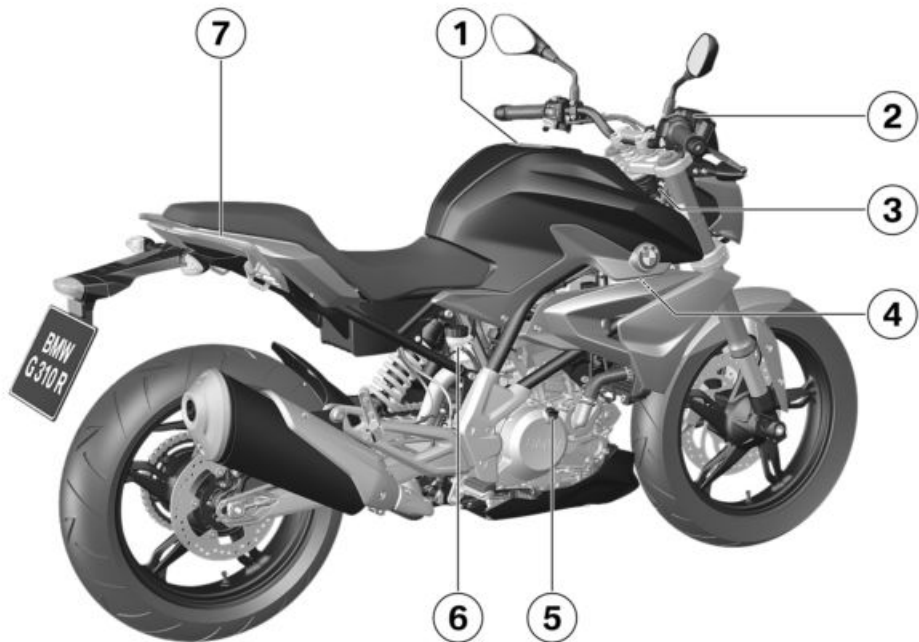

General view, right side

- 1 Fuel filler neck (▣▣▣▣ 55)
- 2 Brake-fluid reservoir, front (▣▣▣▣ 71)
- 3 Vehicle Identification Number
- 4 Coolant expansion tank (▣▣▣▣ 74)
- 5 Oil filler neck (▣▣▣▣ 68)
- 6 Brake-fluid reservoir, rear (▣▣▣▣ 72)
- 7 Grab handle (▣▣▣▣ 46)

Underneath the seat

- 1 Battery (➡ 91)
- 2 Diagnostic connector (➡ 96)
- 3 Fuse box (➡ 94)
- 4 Rider's Manual (➡ 6)
- 5 Toolkit (➡ 64)

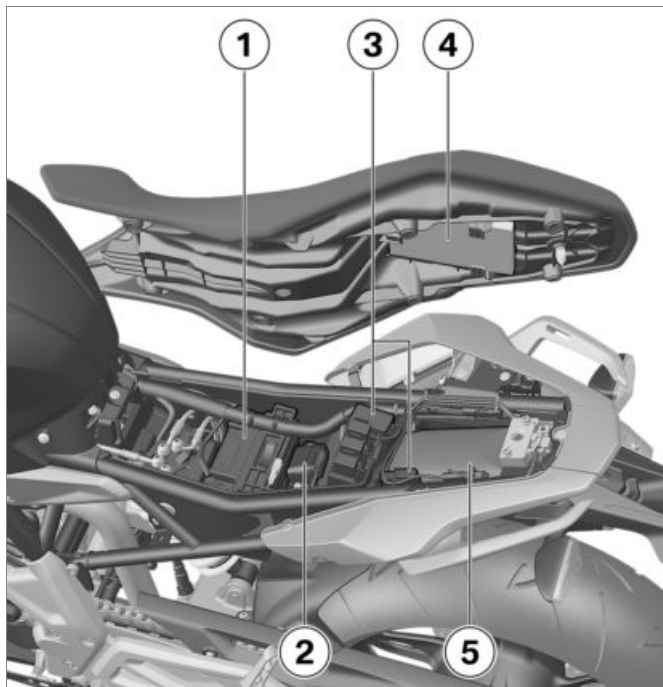

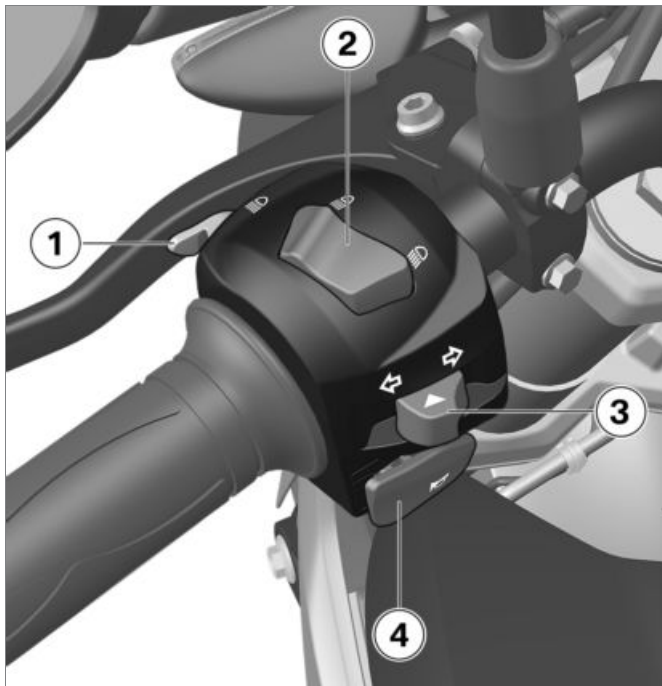

Multifunction switch, left

- 1 Headlight flasher (➡ 34)
- 2 High beam/low-beam headlight rocker switch (➡ 34)
- 3 Turn indicators (➡ 34)
- 4 Horn

Multifunction switch, right

- 1 Emergency off switch (kill switch) (☞ 33)
- 2 Starter button (☞ 33)
(☞ 48)

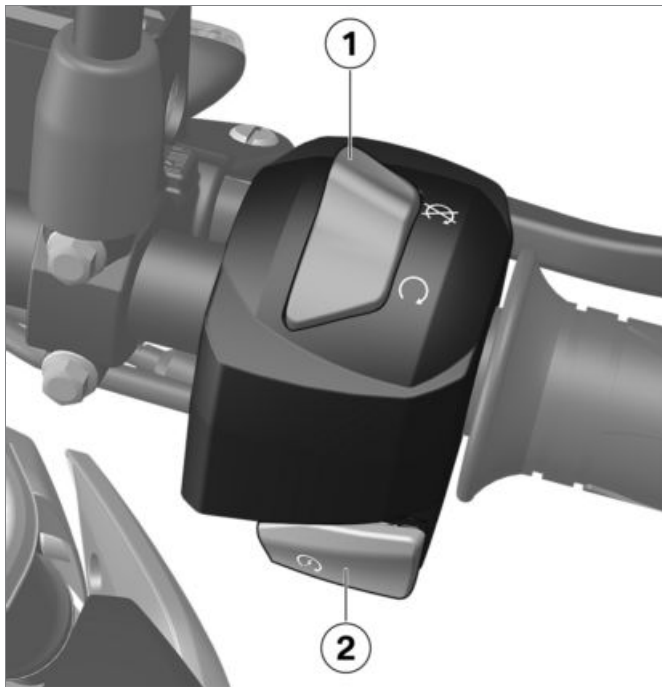

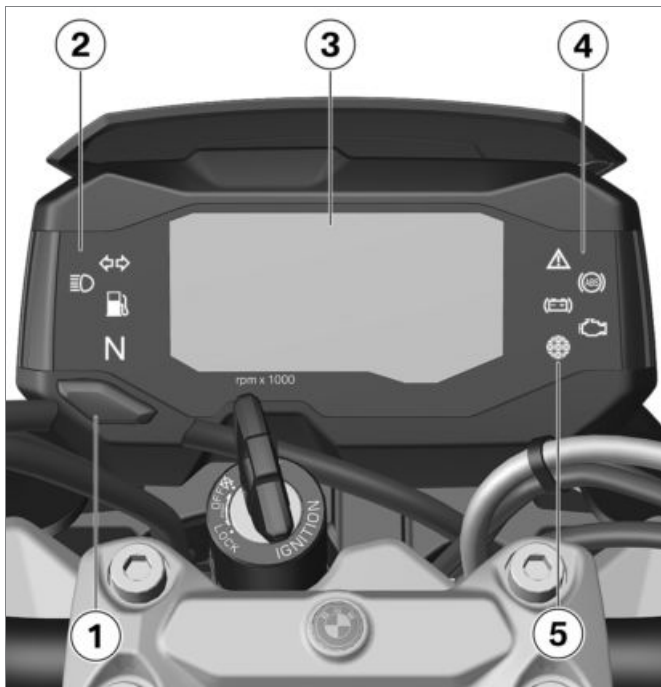

Instrument panel

- 1 Pushbutton
Select display (➡ 36).
- 2 Telltale lights (➡ 20)
- 3 Multifunction display
(➡ 21)
- 4 Warning lights (➡ 20)
- 5 Photosensor for the brightness control in the multifunction display
rpm redline warning
(➡ 52).

Status indicators

Warning and telltale lights.....	20
Multifunction display	21
Warnings	22
Service-due indicator	28
Fuel reserve	29
Engine speed display	30

Warning and telltale lights

- 1 Telltale light for neutral
- 2 High-beam headlight telltale light (→ 34)
- 3 Turn signal indicator light (→ 34)
- 4 Fuel reserve indicator light (→ 27) (→ 29)
- 5 Warning light for vehicle voltage (→ 25)
- 6 General warning light (→ 22)
- 7 ABS warning light (→ 27)
- 8 Malfunction indicator lamp (→ 26)

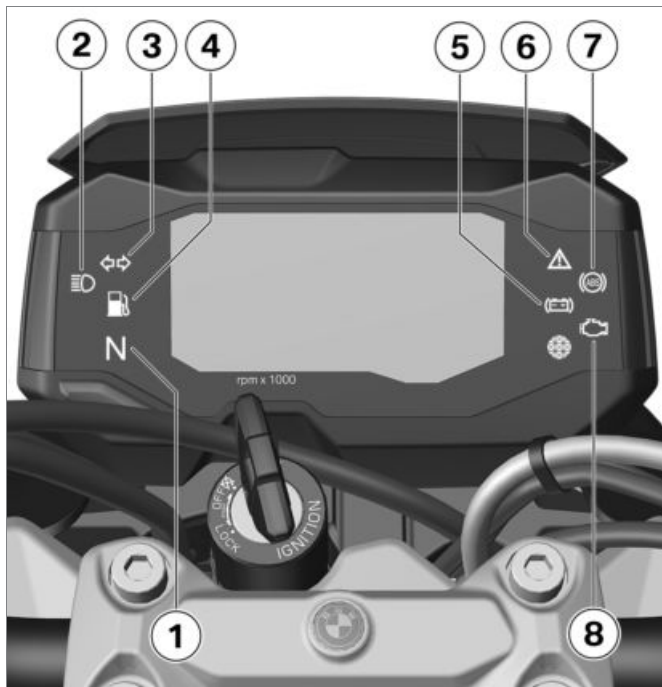

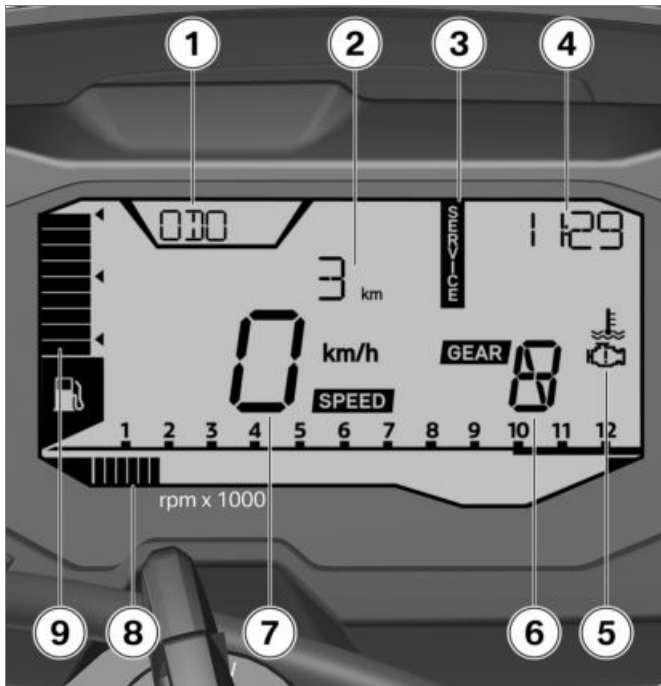

Multifunction display

- 1 On-board computer (➡ 36)
- 2 Display area for values
- 3 Service-due indicator (➡ 28)
- 4 Clock (➡ 37)
- 5 Warning symbols (➡ 22)
- 6 Gear, "N" is displayed when idling
- 7 Speed
- 8 Engine speed (➡ 30)
- 9 Fuel level (➡ 27) (➡ 29)

Warnings

Mode of presentation

Warnings are indicated by the corresponding warning lights. If two or more warnings occur at the same time, all the appropriate warning lights and warning symbols appear. The possible warnings are listed on the next pages.

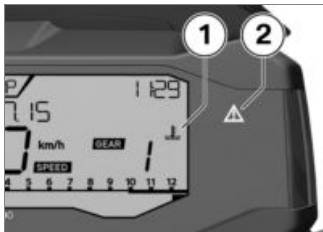









Warnings for which there are no separate warning lights are represented by a warning symbol **1** in the multifunction display and the general warning light **2**. De-

pending on how urgent the warning is, the general warning light will either light up or flash red or yellow.

Warnings, overview

Telltale and warning lights

Warning symbols in the display

Telltale and warning lights	Warning symbols in the display	Meaning
 Warning light for vehicle voltage lights up.		Vehicle voltage is too low (▬▬▬▶ 25)
 General warning light flashes red.	 Temperature symbol appears on the display.	Coolant temperature too high (▬▬▬▶ 25)
 General warning light shows yellow.	 The engine electronics symbol appears on the display.	Engine in emergency-operation mode (▬▬▬▶ 25)
 General warning light flashes yellow.	 The engine electronics symbol appears on the display.	Engine warning (▬▬▬▶ 26)
 The malfunction indicator lamp lights up.		Emissions warning (▬▬▶ 26)

Telltale and warning lights**Warning symbols in the display****Meaning**

ABS telltale and warning light flashes.

ABS self-diagnosis not completed (▬▬▬▬➔ 27)



ABS telltale and warning light shows.

ABS fault (▬▬▬▬➔ 27)



Fuel reserve indicator light lights up.

Fuel down to reserve (▬▬▬▬➔ 27)



General warning light shows yellow.

SERVICE appears permanently on the display.

Service appointment has passed (▬▬▬▬➔ 28)

Vehicle voltage is too low



Warning light for vehicle voltage lights up.



WARNING

Discharged battery causes various motorcycle systems to fail, such as lighting, engine or ABS

Risk of accident

- Do not continue your journey. ◀

Possible cause:

Battery is faulty.

- Have the fault rectified as quickly as possible by a specialist workshop, preferably an authorised BMW Motorrad dealer.

Coolant temperature too high



General warning light flashes red.



Temperature symbol appears on the display.



ATTENTION

Riding with overheated engine

Engine damage

- Compliance with the information set out below is essential. ◀

Possible cause:

The coolant level is too low.

- Check coolant level (▶▶▶ 74).

If the coolant level is too low:

- Top up coolant (▶▶▶ 75).

Possible cause:

The radiator is dirty.

- Clean radiator (▶▶▶ 109).

Possible cause:

The fan or fan control is faulty.

- Have the fault rectified as quickly as possible by a specialist workshop, preferably

an authorised BMW Motorrad dealer.

Possible cause:

The coolant circuit is faulty.

- If possible, allow the engine to cool down.
- Only ride in partial load range.
- If the coolant temperature is often too high, have the fault rectified as soon as possible by a specialist workshop, preferably an authorised BMW Motorrad dealer.

Engine in emergency-operation mode



General warning light shows yellow.



The engine electronics symbol appears on the display.

WARNING

Unusual ride characteristics when engine running in emergency-operation mode

Risk of accident

- Adapt your style of riding accordingly: avoid accelerating sharply and overtaking.◀

Possible cause:

The engine control unit has diagnosed a fault which impairs the engine performance or throttle response. The engine is in emergency-operation mode. In exceptional cases, the engine stops and refuses to start.

- Have the fault rectified as quickly as possible by a specialist workshop, preferably an authorised BMW Motorrad dealer.
- » It is possible to continue riding, however the engine performance and engine speed range

may be impaired and not function as normal.

Engine warning



General warning light flashes yellow.



The engine electronics symbol appears on the display.

WARNING

Engine damage when running in emergency-operation mode

Risk of accident

- Adapt your style of riding accordingly: ride slowly, avoid sharp accelerating and overtaking.
- If possible, have the vehicle brought in and the fault rectified by a specialist workshop, preferably an authorised BMW Motorrad dealer.◀

Possible cause:

The engine control unit has diagnosed a fault which may cause severe secondary faults. The engine is in emergency-operation mode.

- Avoid high load and rpm ranges if possible.
- Have the fault rectified as quickly as possible by a specialist workshop, preferably an authorised BMW Motorrad dealer.
- » It is possible to continue to ride but not recommended.

Emissions warning



The malfunction indicator lamp lights up.

Possible cause:

The engine control unit has diagnosed a fault which affects the pollutant emissions.

- Have the fault rectified by a specialist workshop, preferably

an authorised BMW Motorrad dealer.

- » You can continue riding; pollutant emissions are higher than the threshold values.

ABS self-diagnosis not completed

 ABS telltale and warning light flashes.

Possible cause:

 ABS self-diagnosis not completed

The ABS function is not available, because self-diagnosis did not complete. (The motorcycle has to reach a defined minimum speed for the wheel sensors to be checked: min 5 km/h)

- Pull away slowly. Bear in mind that the ABS function is not available until self-diagnosis has completed.

ABS fault

 ABS telltale and warning light shows.

Possible cause:

The ABS control unit has detected a fault. The ABS function is not available or the functionality is subject to certain restrictions.

- You can continue to ride the vehicle, but make due provision for the fact that the ABS function is not available or is only conditionally available. Please refer to the more detailed information on situations that may lead to an ABS fault (►► 61).
- Have the fault rectified as quickly as possible by a specialist workshop, preferably an authorised BMW Motorrad dealer.

Fuel down to reserve

 Fuel reserve indicator light lights up.

 **WARNING**

Irregular engine operation or engine shutdown due to lack of fuel

Risk of accident, damage to catalytic converter

- Do not run the fuel tank dry. ◀

Possible cause:

The fuel has all been used up; only the fuel reserve remains.

 Fuel reserve

approx. 1 l

- Refuelling (►► 55).

Service appointment has passed



General warning light shows yellow.

SERVICE appears permanently on the display.

Possible cause:

The driving performance or the date indicate that servicing is due.

- Have your motorcycle serviced regularly by a specialist workshop, preferably an authorised BMW Motorrad dealer.
- » The motorcycle remains operationally safe and is suitably road-safe.
- » The value of the motorcycle is preserved to the greatest possible extent.

Service-due indicator Remaining distance until service is due and service due date



If servicing is due in less than 1000 km, the SERVICE message **1** and the remaining distance **2** are shown on the display and the distance is counted down in increments of 100 km. This appears briefly on the display after the Pre-Ride-Check.

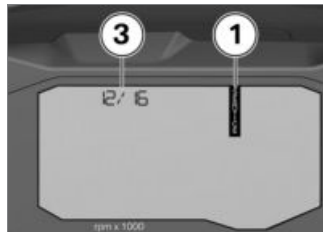

If servicing is due in less than one month, the SERVICE message **1** and the service due date **3** are shown on the display.



If both the distance covered and the service due date indicate that servicing is due, the SERVICE

message **1**, the remaining distance **2** and the service due date **3** are shown on the display.

Permanent SERVICE message

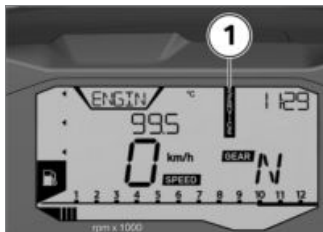

If the service appointment date has passed or the remaining distance until the service is due has been exceeded, **SERVICE 1** is shown permanently on the display when the motorcycle is in operation.

Fuel reserve Range

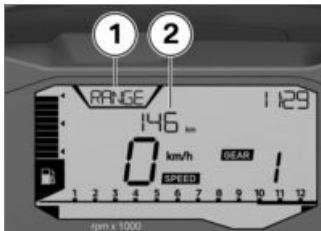

The range **RANGE 1** indicates how far you can ride **2** with the remaining fuel in the tank. This distance is calculated on the basis of average consumption and the quantity of fuel on board.

– When the motorcycle is propped on its side stand the slight angle of inclination means that the sensor cannot register the fuel level correctly. This is the reason why the range is recalculated only when the side stand is folded in.

- The range reading appears automatically on the multifunction display when fuel is down to the reserve level.
- After a refuelling stop, the range is recalculated if the quantity of fuel in the tank is greater than the reserve quantity.
- The calculated range is only an approximate figure.

Engine speed display

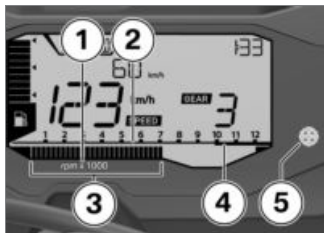

- 1 Unit for engine speed display:
1000 revolutions per minute
- 2 Low engine speed range
- 3 Segments for engine speed display
- 4 High engine speed range
- 5 rpm redline warning (||||► 52).

Operation

Ignition.....	32
Lights.....	34
Turn indicators.....	34
Multifunction display	36
Date and time	37
Reset the trip distance	37
Resetting the average values	38
Seat	38

Ignition Keys

You receive 2 vehicle keys. Ignition switch/steering lock, fuel filler cap lock and seat lock are all operated with the same key.

Lock the handlebars



ATTENTION

Handlebars turned in wrong direction when motorcycle propped on side stand

Risk of damage to parts if vehicle topples

- On level ground, always turn the handlebars to the left to set the steering lock.
- In all other cases it is the lie of the ground that determines the direction in which the handlebars should be turned. ◀

- If the camber of the roadway permits, turn the handlebars all the way to the left.

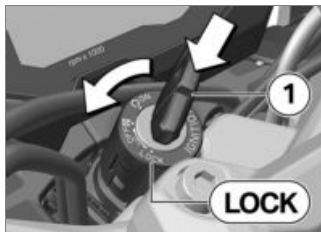

- Insert the ignition key **1** into the steering lock and turn it to the **LOCK** position while moving the handlebars slightly.
 - » Ignition, lights and all function circuits are switched off.
 - » Handlebars are locked.
 - » Vehicle key can be removed.

Switching on ignition



- Insert the ignition key **1** into the ignition steering lock and turn to the **ON** position.
 - » Side lights, low-beam headlight and all function circuits are switched on.
 - » Engine can be started.
 - » Pre-Ride-Check is performed. (▶▶▶ 49)
 - » ABS self-diagnosis is performed (▶▶▶ 50)

Switching off ignition

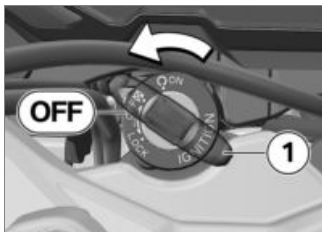

- Turn the ignition key **1** to the **OFF** position.
 - » Handlebars (steering lock) are not locked.
 - » Vehicle key can be removed.

Emergency off switch (kill switch)



A = Operation mode



B = Emergency-off (engine is switched off)

Emergency-off or operation mode



WARNING

Operation of the kill switch while riding

Risk of fall due to rear wheel locking

- Do not operate the kill switch when riding. ◀



- Push the emergency-off switch **1** forwards to switch off the engine quickly and easily.
- Push the emergency-off switch **1** back to start the engine.

Lights

Low-beam headlight and sidelights

The low-beam headlight and side light switch on automatically when the ignition is switched on.



NOTICE

The low-beam headlight and the side light drain the battery. Do not switch the ignition on for longer than absolutely necessary. ◀

High-beam headlight, operating



- Press the switch **1** down away from you.
- » The high beam is switched on.



High beam indicator light lights up.

- Press the switch **1** down towards you.
- » The blue high beam indicator light goes out.
- » Low-beam headlight is switched on.

Headlight flasher, operating

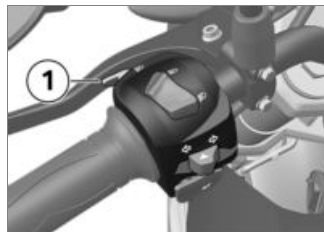

- Press button **1**.
- » The high-beam headlight is switched on until you release the button.

Turn indicators

Operating the turn indicators

- Switching on ignition (▶▶ 32).



- Push the switch **1** to the left.
» The left turn indicator is switched on.



The turn indicator telltale light flashes.

- Push the switch **1** to the right.
» The right turn indicator is switched on.



The turn indicator telltale light flashes.

- Push the switch **1** to the centre position to switch off the turn indicators.

Multifunction display

Select display

Requirement

The vehicle is at a standstill.

- Switch on the ignition.
- » The on-board computer readings appear on the display.
- Repeatedly short-press button **1** until the reading shows the value you want.

Possible displays:

- Total distance travelled: ODO
- Trip distance 1: TRIP1
- Trip distance 2: TRIP2
- Coolant temperature: ENGIN
- Range: RANGE
- Average fuel consumption: CONS1
- Current fuel consumption: CONSA
- Average speed: SPEED
- Date: DATE
- Settings: SETUP

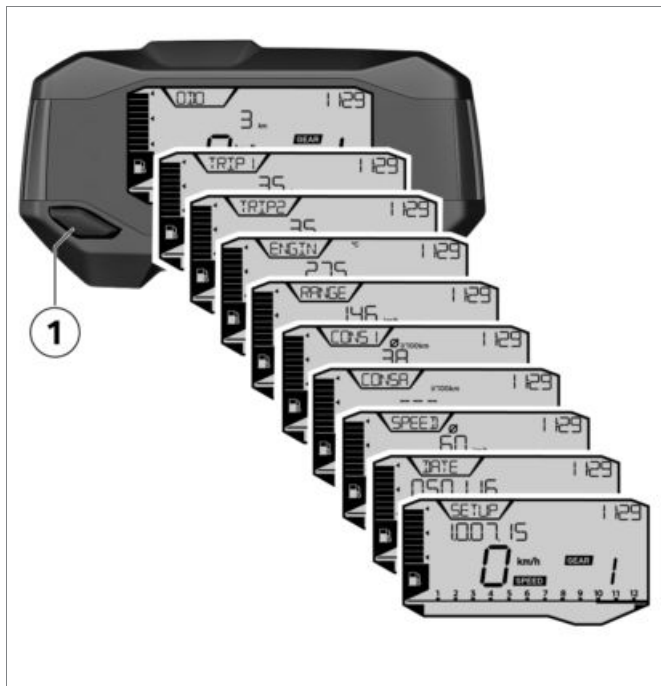

Date and time

Setting the clock

- Select display (➡ 36).
- » SETUP 2 appears on the display.

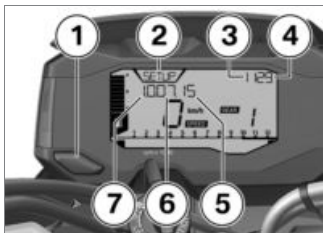

- Press and hold button **1**.
- » Hours reading **3** flashes.
- Press button **1** briefly and repeatedly to change the hour **3** (increases).
- Once you have set the hour correctly, press and hold button **1**.
- » Minutes reading **4** flashes.

- Press button **1** briefly and repeatedly to change the minutes (increases).
- Once you have set the minutes correctly, press and hold button **1**.
- » The time has not been saved yet!
- Setting the date (➡ 37).

Setting the date

Requirement

Time has been set.

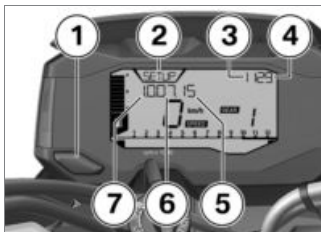

- Press button **1** briefly and repeatedly to change the day **7** (increases).

- Once you have set the day correctly, press and hold button **1** down.
- » Month **6** flashes.
- Press the same button **1** again briefly and repeatedly to change the month **6** (increases).
- Once you have set the month correctly, press and hold button **1** down.
- » Year **5** flashes.
- Press the button **1** again briefly and repeatedly to change the year (increases).
- Once you have set the year correctly, press and hold button **1** down.
- » The time and date have been saved.

Reset the trip distance

- Select display (➡ 36).

- » The trip distances **2** which need resetting have been selected.
- TRIP1 or TRIP2 appears on the display.

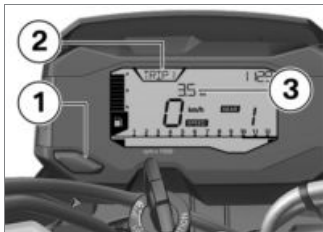

- Press and hold button **1** until the value **3** has been reset.

Resetting the average values

- Select display (☰ → 36).
- » The average value **2** which needs resetting has been selected.

- CONSI or SPEED appears on the display.

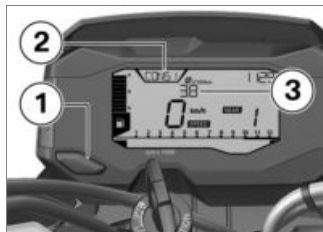

- Press and hold button **1** until the value **3** has been reset.

Seat

Remove seat

- Make sure the ground is level and firm and place the motorcycle on its stand.

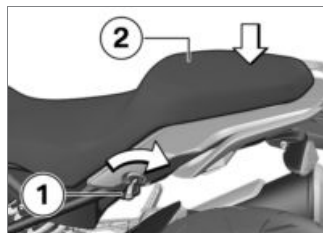

- Push the rear seat bench **2** down to relieve the strain on the lock, and at the same time use the ignition key to unlock the seat lock **1** by turning it clockwise.
- Lift the seat at the rear and remove.
- Lay the seat on a clean surface.

Installing the seat

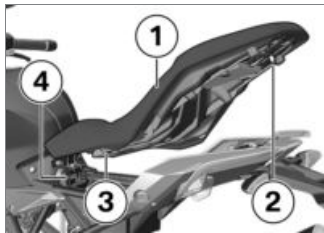

- Fit the seat bench **1** with the fixture **3** centrally into the battery tray **4**.
- Attach the detent pin **2** and push it into the lock.

Adjustment

Mirrors	42
Headlight	42
Spring preload	44

Mirrors

Adjusting mirrors



- Turn the mirror to the desired position.

Adjusting mirror arm

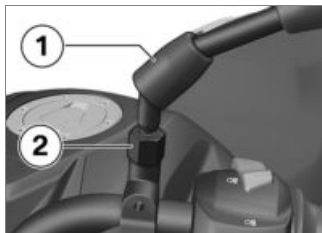

- Push protective cap **1** for the threaded fastener up on the mirror arm.
- Slacken locknut **2**.
- Turn the mirror arm to the appropriate position.
- Tighten the locknut to the specified tightening torque, while holding the mirror arm to ensure that it does not move out of position.



Right mirror (lock nut) to adapter

22 Nm (Left-hand thread)



Left mirror (lock nut) to adapter

22 Nm

- Push protective cap **1** over the threaded fastener.

Headlight

Adjusting headlight for driving on left/driving on right

This motorcycle has a symmetric-beam low-beam headlight. If the motorcycle is ridden in a country where the opposite rule of the road applies, its symmetric low-beam headlight means that no measures are necessary to prevent the headlight beam from dazzling oncoming traffic.

Headlight beam throw and spring preload

Headlight beam throw is generally kept constant when spring preload is adjusted to suit load. Headlight beam throw is set correctly ex-works.

NOTICE

If there are doubts about the correct headlight beam throw, have the setting checked by a specialist workshop, preferably an authorised BMW Motorrad dealer. ◀

Adjusting headlight beam throw

Requirement

Despite the spring preload being adjusted, oncoming traffic is still dazzled if the payload is high.



- Remove screws **1**.
- Remove front trim panel **2** on left and right.



- Loosen the bolt **3** on both sides.

- Turn the headlight around the bolt axis to adjust the headlight beam throw.
- Tighten the bolt **3** on both sides.

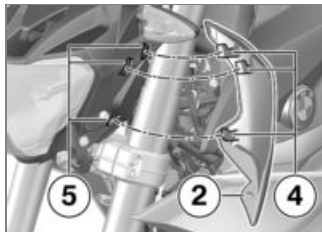

- Attach the front trim panel **2** using hooks **4** to the front mask **5**.

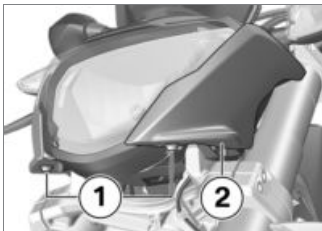

- Install screws **1**.
- When the motorcycle is again ridden with a lower load:
- Readjust the headlight beam throw.

Spring preload

Adjustment

Spring preload has to be adjusted to suit the weight of rider, passenger and luggage. Increase spring preload for heavier riders, decrease spring preload for lighter riders.

Adjusting spring preload for rear wheel

- Make sure the ground is level and firm and place the motorcycle on its stand.

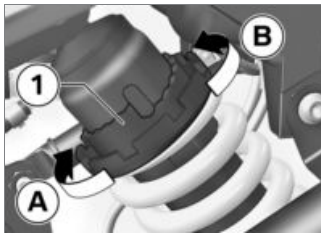

- To increase the spring preload, turn the adjusting ring **1** in the direction of arrow **A** using the tool from the toolkit.
- To reduce the spring preload, turn the adjusting ring **1** in the direction of arrow **B** using the tool from the toolkit.



Basic setting of spring preload, rear

Stage 1 (One-up riding without luggage)

Stage 5 (One-up with luggage)

Stage 10 (Two-up riding and luggage)

Riding

Safety instructions	46
Checklist.....	48
Starting	48
Running in	51
rpm redline warning.....	52
Brakes	52
Parking your motorcycle	53
Refuelling	54
Securing motorcycle for transportation	56

Safety instructions

Rider's equipment

Do not ride without the correct clothing:

- Helmet
- Motorcycling jacket and trousers
- Gloves
- Boots

This applies even to short journeys, and to every season of the year. Your authorised BMW Motorrad dealer will be glad to advise you on the correct clothing for every purpose.

Loading



WARNING

Handling adversely affected by overloading and imbalanced loads

Risk of falling

- Do not exceed the permissible gross weight and be sure to comply with the instructions on loading.◀
- Set spring preload to suit total weight.
 - with topcase^{OA}
 - or
 - with topcase Light^{OA}
- Note the maximum permissible payload and the speed limit for riding with topcase fitted, as stated on the label inside the case (see also the section entitled "Accessories").◀
- Make sure that the weight is uniformly distributed between right and left.
- Store heavy items of luggage at the bottom.

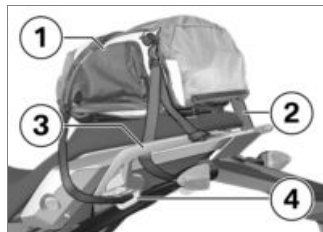

- Lash the luggage **1** securely to the motorcycle.
- Thread the retaining straps **2** through the eyes **3** and **4** and tighten.

Speed

If you ride at high speed, always bear in mind that various boundary conditions can adversely affect the handling of your motorcycle:

- Incorrect adjustment of the spring system
- Imbalanced load
- Loose clothing

- Insufficient tyre pressure
- Poor tyre tread
- Etc.

Top speed



DANGER

Maximum speed of the motorcycle is higher than the permissible maximum rated speed of the tyres

Risk of accident due to tyre damage at high speed

- Comply with the tyre-specific speed restrictions.◀

Risk of poisoning

Exhaust fumes contain carbon monoxide, which is colourless and odourless but highly toxic.



WARNING

Exhaust gases adversely affecting health

Risk of asphyxiation

- Do not inhale exhaust fumes.
- Do not run the engine in an enclosed space.◀

Risk of burn injury



CAUTION

Engine and exhaust system become very hot when the vehicle is in use

Risk of burn injury

- When you park the vehicle make sure that no-one and no objects can come into contact with the hot engine and exhaust system.◀

Catalytic converter

If misfiring causes unburned fuel to enter the catalytic converter, there is a danger of overheating and damage.

For this reason, observe the following points:

- Do not run the fuel tank dry.
- Do not remove the spark plug connector while the engine is running.
- Stop the engine immediately if it misfires.
- Use only unleaded fuel.
- Comply with all specified maintenance intervals.



ATTENTION

Unburned fuel in catalytic converter

Damage to catalytic converter

- Note the points listed for protection of the catalytic converter.◀

Risk of overheating



ATTENTION

Engine running for prolonged period with vehicle at standstill

Overheating due to insufficient cooling; in extreme cases vehicle fire

- Do not allow the engine to idle unnecessarily.
- Ride away immediately after starting the engine.◀

Tampering



ATTENTION

Tampering with the motorcycle (e.g. engine management ECU, throttle valves, clutch)

Damage to the affected parts, failure of safety-relevant functions, voiding of warranty

- Do not tamper with the vehicle in any way that could result in tuned performance.◀

Checklist

Comply with checklist

- At regular intervals, use the checklist below to check your motorcycle.

Always before riding off

- Checking function of brakes (▣▣▣ 68).
- Check that the lights and signalling equipment function.
- Checking clutch function (▣▣▣ 73).
- Checking tyre tread depth (▣▣▣ 75).
- Checking tyre pressure (▣▣▣ 76).
- Check that the luggage is secure.

Every 3rd refuelling stop

- Checking engine oil level (▣▣▣ 67).
- Checking front brake pad thickness (▣▣▣ 69).

- Check rear brake pad thickness (▣▣▣ 70).
- Checking brake-fluid level, front brakes (▣▣▣ 71).
- Checking the brake-fluid level, rear brakes (▣▣▣ 72).
- Check coolant level (▣▣▣ 74).
- Lubricating chain (▣▣▣ 85).
- Checking chain tension (▣▣▣ 84).

Starting

Start engine

- Switch on the ignition.
- » Pre-Ride-Check is performed. (▣▣▣ 49)
- » ABS self-diagnosis is performed (▣▣▣ 50)
- Shift to idle.



Idle mode indicator light lights up.



Idle mode appears on the display.

- Alternative: If a gear is engaged, pull the clutch.



NOTICE

You cannot start the motorcycle with the side stand extended and a gear engaged. The engine will switch itself off if you start it with the gearbox in neutral and then engage a gear before retracting the side stand.◀



NOTICE

If the throttle grip is operated too vigorously, the engine will not start or the current to the starter motor will be interrupted. Hold the throttle grip closed or only operate it gently.◀

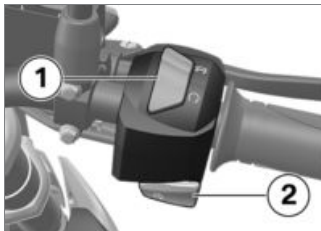

- Set the emergency-off switch **1** to Operation.



Switch is in operation mode.

- Press starter button **2**.



- » The engine starts.
- » Consult the troubleshooting chart below if the engine refuses to start. (▶▶ 112)

Pre-Ride-Check

The instrument cluster runs a test of the warning and indicator lights and the display, known as the Pre-Ride-Check, after the ignition has been switched on. The test is aborted if you start the engine before it completes.

Phase 1

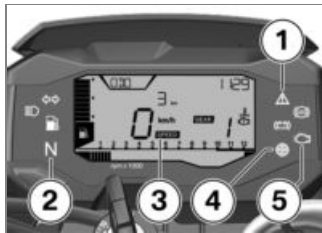

"General" warning light **1** lights up red.

The indicator lights **2** light up.

The last active display **3** is shown on the screen.

The rpm redline warning **4** lights up.

The warning lights **5** light up.

Phase 2

'General' warning light **1** changes from red to yellow.

Phase 3

The warning and indicator lights and the rpm redline warning go out, or they assume operational status.

The malfunction indicator lamp only goes out after 15 seconds.

If servicing is due, this is shown briefly on the screen.

If one of the warning or indicator lights does **not** light up:



WARNING

Faulty warning lights

No indication of malfunctions

- Check all the telltale and warning lights. ◀
- Have the fault rectified as quickly as possible by a specialist workshop, preferably an authorised BMW Motorrad dealer.

ABS self-diagnosis

BMW Motorrad Integral ABS performs self-diagnosis to ensure its operability. Self-diagnosis starts automatically when you switch on the ignition.

Phase 1

- » Test of the diagnosis-compatible system components with the vehicle at a standstill.



ABS telltale and warning light flashes.

Phase 2

- » Test of the wheel-speed sensors as the vehicle pulls away from rest.



ABS telltale and warning light flashes.

ABS self-diagnosis completed

- » The ABS warning light goes out.



ABS self-diagnosis not completed

The ABS function is not available, because self-diagnosis did not complete. (The motorcycle has to reach a defined minimum speed for the wheel sensors to be checked: min 5 km/h)

If an indicator showing an ABS fault appears when ABS self-diagnosis completes:

- You can continue to ride. Bear in mind that neither the ABS function nor the integral braking function is available.

- Have the fault rectified as quickly as possible by a specialist workshop, preferably an authorised BMW Motorrad dealer.

Running in Engine

- Until the running-in check (first inspection), vary the throttle opening and engine-speed range frequently; avoid riding at constant engine rpm for prolonged periods.
- Try to do most of your riding during this initial period on twisting, fairly hilly roads.
- Comply with the rpm limits for running in.



Running-in speed

<6000 min⁻¹ (Odometer reading 0...300 km)



Running-in speed

No full throttle (Odometer reading 0...1000 km)

- Note the mileage after which the running-in check should be carried out.



Mileage until the running-in check

500...1200 km

Brake pads

New brake pads have to bedded in before they can achieve their optimum frictional force. You can compensate for this initial reduction in braking efficiency by exerting greater pressure on the levers.



WARNING

New brake pads

Longer stopping distance, risk of accident

- Apply the brakes in good time.◀

Tyres

New tyres have a smooth surface. This must be roughened by riding in a restrained manner at various heel angles until the tyres are run in. Only once the surface has been roughened can the tyres achieve maximum grip.



WARNING

New tyres losing grip on wet roads and at extreme bank angles

Risk of accident

- Ride carefully and avoid extremely sharp inclines.◀

rpm redline warning

Requirement

The aim is maximum acceleration but the vehicle is not yet in sixth gear.



- Accelerate.

 The rpm redline warning **1** lights up when the following engine speed is reached:
>10000 min⁻¹

- Do not exceed the following engine speed:



Maximum engine speed

max 10800 min⁻¹

- Shift up to the next gear.

Brakes

How can stopping distance be minimised?

Each time the brakes are applied, a load distribution shift takes place with the load shifting forward from the rear to the front wheel. The sharper the vehicle decelerates, the more load is shifted to the front wheel. The higher the wheel load, the more braking force can be transmitted without the wheel locking. In order to achieve the shortest stopping distance, the front wheel brake must be pulled quickly until ABS activates, the pressure point held and the rear wheel brake operated at the

same time. This makes the best possible use of the dynamic increase in load at the front wheel. Remember to pull the clutch at the same time. BMW Motorrad ABS prevents the front wheels from locking. In the "panic braking situations" that are trained so frequently, braking force is applied as rapidly as possible and with the rider's full force applied to the brake levers; under these circumstances, the dynamic shift in load distribution cannot keep pace with the increase in deceleration and the tyres cannot transmit the full braking force to the surface of the road. In the absence of load on the wheel the ABS has to intervene to prevent the front wheel from locking even if the brakes are applied only very lightly. This leads to a reduced braking effect.

Descending mountain passes

WARNING

Braking only with the rear brake on mountain descents

Brake fade, destruction of the brakes due to overheating

- Use both front and rear brakes, and make use of the engine's braking effect as well. ◀

Wet and dirty brakes

Wetness and dirt on the brake discs and the brake pads diminish braking efficiency.

Delayed braking action or poor braking efficiency must be reckoned with in the following situations:

- Riding in the rain or through puddles of water
- After the vehicle has been washed

- Riding on salted or gritted roads
- After work has been carried on the brakes, due to traces of oil or grease
- Riding on dirt-covered surfaces or off-road

WARNING

Wetness and dirt result in diminished braking efficiency

Risk of accident

- Apply the brakes lightly while riding to remove wetness and dirt, or dismount and clean the brakes.
- Think ahead and brake in good time until full braking efficiency is restored. ◀

Parking your motorcycle

Side stand

- Switch off the engine.
- On a gradient, the motorcycle should always face uphill; select 1st gear.



ATTENTION

Poor ground underneath the stand

Risk of damage to parts if vehicle topples

- Always check that the ground under the stand is level and firm. ◀
- Extend the side stand and prop the motorcycle on the stand.



ATTENTION

Additional weight placing strain on the side stand

Risk of damage to parts if vehicle topples

- Do not sit or lean on the vehicle while it is propped on the side stand. ◀
- If the camber of the roadway permits, turn the handlebars all the way to the left.

Centre stand

– with centre stand^{OA}

- Switch off the engine.



ATTENTION

Poor ground underneath the stand

Risk of damage to parts if vehicle topples

- Always check that the ground under the stand is level and firm. ◀



ATTENTION

Centre stand folds in due to sharp movements

Risk of damage to parts if vehicle topples

- Do not lean or sit on the vehicle with the centre stand extended. ◀
- Extend the centre stand and lift the motorcycle onto the stand.
- On a gradient, the motorcycle should always face uphill; select 1st gear.

Refuelling

Fuel grade Requirement

For optimum fuel consumption, fuel should be sulphur-free or with the lowest sulphur content possible.



ATTENTION

Engine operation with leaded fuel

Damage to catalytic converter

- Do not attempt to run the vehicle on leaded fuel or fuel with metallic additives (e.g. manganese or iron). ◀



ATTENTION

Engine operation with ethanol E85

Damage to engine and fuel supply system

- Do not attempt to run the engine on ethanol E85, i.e. a fuel with an ethanol content of 85 %, or flex fuel. ◀
- Check the fuel grade.



Recommended fuel grade

Regular, unleaded (max. 10 % ethanol, E10)
91 ROZ/RON
87 AKI

Refuelling

WARNING

Fuel is highly flammable

Risk of fire and explosion

- Do not smoke. Never bring a naked flame near the fuel tank.◀

WARNING

Escape of fuel due to heat-induced expansion if fuel tank is overfilled

Risk of falling

- Do not overfill the fuel tank.◀

ATTENTION

Wetting of plastic surfaces by fuel

Damage to the surfaces (surfaces become unsightly or dull)

- Clean plastic surfaces immediately after contact with fuel.◀

- Make sure the ground is level and firm and place the motor-cycle on its side stand.

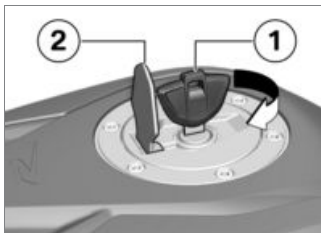

- Open the protective cap **2**.
- Use ignition key **1** to unlock fuel filler cap by turning it clockwise, and flip the cap open.



- Refuel with fuel of the grade stated above; do not fill the tank past the lower edge of the fuel filler neck **3**. Watch the bar across the bottom edge of the filler neck when refuelling, being careful to ensure that the fuel does not spurt out.

NOTICE

When refuelling after running on reserve, make sure that you top up the tank to a level above reserve, as otherwise the new level will not be registered and the fuel warning light indicating that the

level is down to reserve will not be switched off. ◀



NOTICE

The "usable fuel capacity" specified in the technical data is the quantity that the fuel tank could hold if refilled after it had been run dry and the engine had cut out due to a lack of fuel. ◀



Usable fuel capacity

approx. 11 l



Fuel reserve

approx. 1 l

- Unlock the fuel tank cap by turning the ignition key **1** clockwise and close it again by pressing firmly down.
- Remove the ignition key and close the protective cap.

Securing motorcycle for transportation

- Make sure that all components that might come into contact with straps used to secure the motorcycle are adequately protected against scratching. Use adhesive tape or soft cloths, for example, for this purpose.



ATTENTION

Vehicle topples to side when being lifted on to stand

Risk of damage to parts if vehicle topples

- Secure the vehicle to prevent it toppling, preferably with the assistance of a second person. ◀
- Push the motorcycle onto the transportation flat and hold it in position: do not place it on the side stand.



ATTENTION

Trapping of components

Component damage

- Do not trap components such as brake lines or cable legs. ◀

- At the front, loop a strap over the bottom fork bridge on each side.
- Pull the straps down and tight.

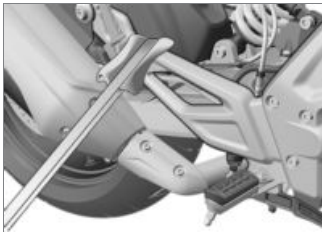

- At the rear, secure the straps to the rear footrests on both sides and tighten the straps.
- Uniformly tighten all the straps.
- » The motorcycle is lashed down securely.

Engineering details

General instructions.....	60
Anti-lock brake system	60

General instructions

To find out more on the subject of engineering go to:

bmw-motorrad.com/technik

Anti-lock brake system

How does ABS work?

The amount of braking force that can be transferred to the road depends on factors that include the coefficient of friction of the road surface. Loose stones, ice and snow or a wet road all have much lower coefficients of friction than a clean, dry asphalt surface. The lower the coefficient of friction, the longer the braking distance.

If the rider increases braking pressure to the extent that braking force exceeds the maximum transferable limit, the wheels start to lock and the motorcycle loses its directional stability. A fall is imminent. Before this situ-

ation can occur, ABS intervenes and adapts brake pressure to the maximum transferable brake force, so the wheels continue to turn and driving stability is maintained irrespective of the condition of the road surface.

What are the effects of surface irregularities?

Humps and surface irregularities can cause the wheels to lose contact temporarily with the road surface; if this happens the braking force that can be transmitted to the road can drop to zero. If the brakes are applied under these circumstances the ABS has to reduce braking force to ensure that directional stability is maintained when the wheels regain contact with the road surface. At this instant the ABS must assume an extremely low coefficient of friction, so that the wheels will continue to rotate un-

der all imaginable circumstances, because this is the precondition for ensuring directional stability. As soon as it registers the actual circumstances, the system reacts instantly and adjusts braking force accordingly to achieve optimum braking.

Rear wheel lift

Even under severe braking, a high level of tyre grip can mean that the front wheel does not lock up until very late, if at all. Consequently, ABS does not intervene until very late, if at all. Under these circumstances the rear wheel can lift off the ground, and the outcome can be a high-siding situation in which the motorcycle can flip over.

WARNING

Rear wheel lift due to severe braking

Risk of falling

- When you brake sharply, bear in mind that ABS control cannot always be relied on to prevent the rear wheel from lifting clear of the ground.◀

Special situations

The speeds of the front and rear wheels are compared as one means of detecting a wheel's incipient tendency to lock. If the system registers implausible values for a lengthy period the ABS function is deactivated for safety reasons and an ABS fault message is issued. Self-diagnosis has to complete before fault messages can be issued. In addition to problems with the BMW Motorrad ABS, exceptional

riding conditions can lead to a fault message being issued. If a fault message should be triggered due to one of the above-described driving conditions, the ABS function can be re-activated by switching the ignition off and then on again.

Exceptional riding conditions:

- Heating up with the motorcycle on an auxiliary stand, in neutral or with a gear engaged.
- Rear wheel locked by the engine brake for a lengthy period, for example while descending steep gradients.

What significance devolves on regular maintenance?

WARNING

Brake system not regularly serviced

Risk of accident

- In order to ensure that the BMW Motorrad ABS is always maintained in optimum condition, it is essential for you to comply strictly with the specified inspection intervals.◀

Reserves for safety

The potentially shorter stopping distances which BMW Motorrad ABS permits must not be used as an excuse for careless riding. ABS is primarily a means of ensuring a safety margin in genuine emergencies.

Take care when cornering! When you apply the brakes on a corner, the motorcycle's weight and momentum take over and even BMW Motorrad ABS is unable to counteract their effects.

Maintenance

General instructions.....	64
Toolkit	64
Front-wheel stand	65
Rear-wheel stand	66
Engine oil	67
Brake system	68
Clutch	73
Coolant	74
Wheel rims and tyres	75
Wheels	76
Chain	84
Light source	86
Jump-starting.....	90
Battery.....	91
Fuses	94

Diagnostic connector	96
----------------------------	----

General instructions

The Maintenance chapter describes straightforward procedures for checking and replacing certain wear parts.

Special tightening torques are listed as applicable. The tightening torques for the threaded fasteners on your vehicle are listed in the section entitled "Technical data".

You will find information on more extensive maintenance and repair work in the repair Instruction on DVD for your vehicle, which is available from your authorised BMW Motorrad dealer.

Some of the work calls for special tools and a thorough knowledge of the technology involved. If you are in doubt, consult a specialist workshop, preferably your authorised BMW Motorrad dealer.

Toolkit

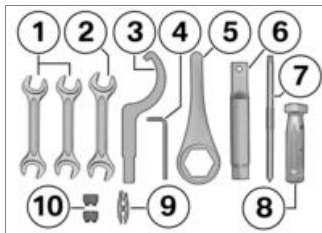

- 1** Open-ended spanner
Width across flats 12/13
– Adjust the chain tension (►► 84).
- 2** Open-ended spanner
Width across flats 10/16
– Adjusting mirror arm (►► 42).
– Removing battery (►► 93).
- 3** Hook wrench
– Adjusting spring preload for rear wheel (►► 44).
- 4** Allen key
5 mm
- 5** Ring spanner
Width across flats 27
– Removing rear wheel (►► 80).
– Adjust the chain tension (►► 84).
- 6** Extension for hook wrench and ring spanner
- 7** Reversible screwdriver blade
with cross head
– Replacing bulbs for front and rear turn indicators (►► 89).
- 8** Screwdriver handle
- 9** Gripping clamp
Gripping clamp is affixed to the battery holder.
– Replace fuses (►► 94).
- 10** Fuses
10 A, 15 A and 30 A

- 4** – Open the front mask (►► 86).
– Adjusting headlight beam throw (►► 43).

- 10** – Reserve fuses are located in the fuse box and are hanging on the cable for the diagnostic connector.

Front-wheel stand

Installing the front-wheel stand



ATTENTION

Use of the BMW Motorrad front wheel stand without accompanying use of centre stand or auxiliary stand

Risk of damage to parts if vehicle topples

- Place the motorcycle on its centre stand or another auxiliary stand before lifting the front wheel with the BMW Motorrad front-wheel stand. ◀

- with centre stand^{OA}
 - Make sure the ground is level and firm and place the motorcycle on its centre stand. ◀

- without centre stand^{OA}
 - Place the motorcycle on an auxiliary stand; BMW Motorrad recommends the BMW Motorrad auxiliary stand.
 - Install the rear-wheel stand (▶▶ 66). ◀
 - Use basic stand with front-wheel adapter.
 - » The basic stand and its accessory parts are available from your BMW Motorrad dealer.

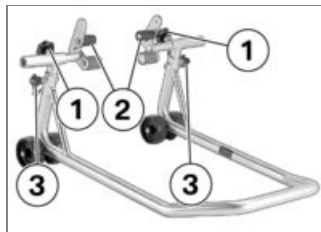

- Slacken clamping screws **1**.
- Push the two adapters **2** apart until the front forks fit between them.
- Use locating pins **3** to set the front-wheel stand to the desired height.
- Centre the front-wheel stand relative to the front wheel and push it against the front axle.

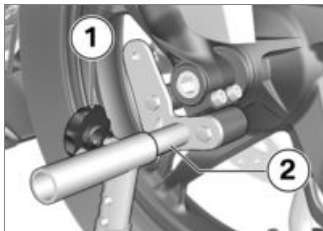

- Align the two adapters **2** so that the front forks are securely seated.
- Tighten clamping screws **1**.

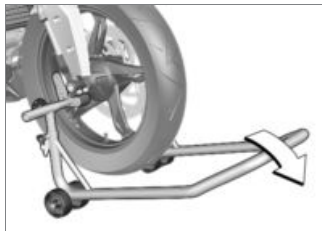

ATTENTION

Centre stand retracts if motorcycle is lifted too high

Risk of damage to parts if vehicle topples

- When raising the vehicle, make sure that the centre stand remains on the ground. ◀
- Apply uniform pressure to push the front-wheel stand down and raise the motorcycle.

Rear-wheel stand

Install the rear-wheel stand

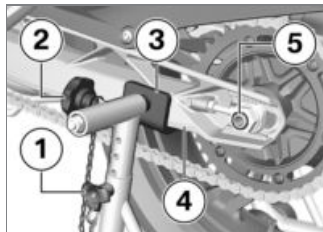

- Set the height of the stand **3** so that it raises the rear wheel slightly off the ground.
- Ensure that the stand height is the same on the left and right, and secure the mount **3** on either side with bolts **1**.
- Set the mounts **3** to the width of the rear wheel swinging arm **4** and secure using clamping bolts **2**.
- Ensure you do not cover the axle **5**.

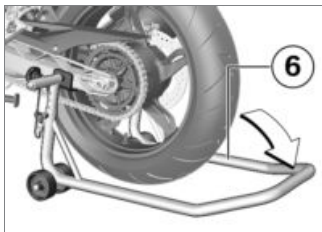

- Position the rear-wheel stand **6**.

ATTENTION

Vehicle toppling to side

Risk of damage to parts if vehicle topples

- Make sure that the vehicle is secured so that it cannot topple sideways.◀
- Push the rear-wheel stand down until the motorcycle is standing upright and the handle of the rear-wheel stand is resting on the floor.

Engine oil

Checking engine oil level Requirement

The engine is at operating temperature.

ATTENTION

Use of insufficient engine oil or too much engine oil

Engine damage

- Always make sure that the oil level is correct.◀
 - with centre stand^{OA}
 - Make sure the ground is level and firm and place the motorcycle on its centre stand.◀
 - without centre stand^{OA}
 - Place the motorcycle on an auxiliary stand; BMW Motorrad recommends the BMW Motorrad auxiliary stand.

- Alternative: hold the motorcycle upright, ideally with help from another person.◀

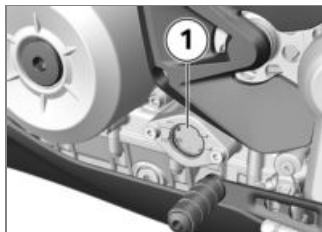

- Check the oil level in oil-level indicator **1**.

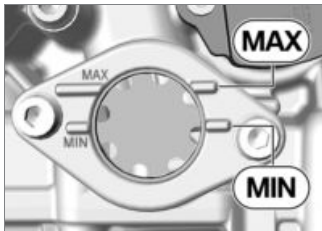

Engine oil, specified level

Between **MIN** and **MAX** marks (Engine is at operating temperature, motorcycle is upright)



Engine oil, quantity for topping up

max 185 ml (Difference between **MIN** and **MAX**)

If the oil level is below the minimum mark **MIN**:

- Topping up the engine oil (▣▣▣ 68).

If the oil level is above the maximum mark **MAX**:

- Have the oil level corrected by a specialist workshop, preferably an authorised BMW Motorrad dealer.

Topping up the engine oil

- Make sure the ground is level and firm and place the motorcycle on its stand.
- Wipe the area around the oil filler neck clean.

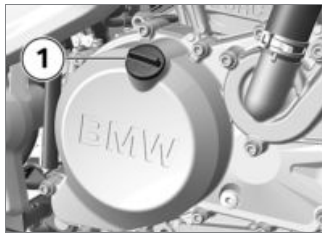

- Remove cap **1** of the oil filler neck.



ATTENTION

Use of insufficient engine oil or too much engine oil

Engine damage

- Always make sure that the oil level is correct. ◀
- Top up the engine oil to the specified level.
- Checking engine oil level (▣▣▣ 67).
- Install oil filler cap **1**.

Brake system

Checking function of brakes

- Operate the brake lever.
 - » There is a clearly perceptible pressure point.
- Press the footbrake lever.
 - » There is a clearly perceptible pressure point.

If pressure points are not clearly perceptible:

ATTENTION

Work on brake system not in compliance with correct procedure

Risk to operational reliability of the brake system

- Have all work on the brake system undertaken by trained and qualified specialists. ◀
- Have the brakes checked by a specialist workshop, preferably an authorised BMW Motorrad dealer.

Checking front brake pad thickness

- Make sure the ground is level and firm and place the motorcycle on its stand.

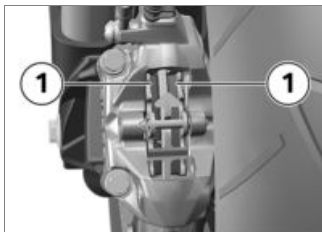

- Turn the handlebars all the way to the right.
 - » The brake pads **1** can be seen from the rear.
- Visually inspect the brake pads to ascertain their thickness.

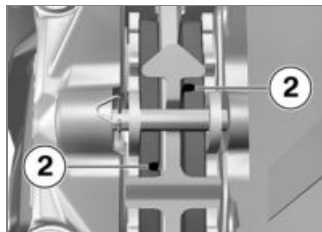

- Check the wear indicators **2**.

 Brake-pad wear limit, front

min 1.0 mm (Friction lining without carrier plate)

If the wear indicating marks are no longer visible:

WARNING

Brake-pad thickness less than permissible minimum

Diminished braking effect, damage to the brakes

- In order to ensure the dependability of the brake system, do not permit the brake pads to wear past the minimum permissible thickness. ◀
- Have the brake pads replaced by a specialist workshop, preferably an authorised BMW Motorrad dealer.
- BMW Motorrad recommends you only install genuine brake pads from BMW Motorrad.

Check rear brake pad thickness

- Make sure the ground is level and firm and place the motorcycle on its stand.

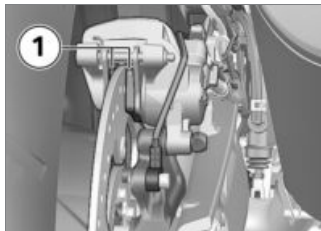

WARNING

Brake-pad thickness less than permissible minimum

Diminished braking effect, damage to the brakes

- In order to ensure the dependability of the brake system, do not permit the brake pads to wear past the minimum permissible thickness. ◀
- Visually inspect the brake pads to ascertain their thickness. Viewing direction: from the rear toward brake pads **1**.

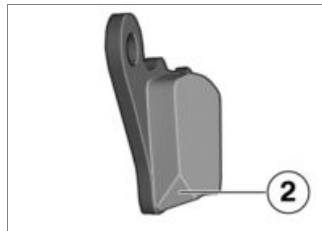

- Inspect the chamfer **2**.

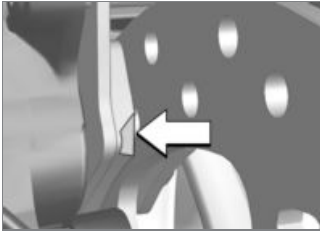

 Brake-pad wear limit, rear

min 1.0 mm (Friction lining without carrier plate. The wear indicators must be clearly visible.)

If the chamfer is no longer visible:

- Have the brake pads replaced by a specialist workshop, preferably an authorised BMW Motorrad dealer.

Checking brake-fluid level, front brakes

WARNING

Not enough brake fluid in brake fluid reservoir

Considerably reduced braking power due to air in the brake system

- Check the brake-fluid level at regular intervals.◀



- Set the handlebars so that the brake fluid tank is horizontal.
- Check the brake fluid level in the sight glass **1**.

NOTICE

Wear of the brake pads causes the brake fluid level in the reservoir to sink.◀

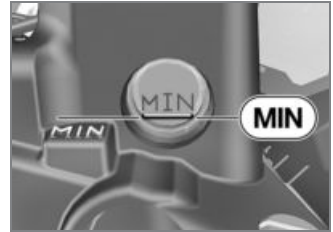

 Brake fluid level, front

Brake fluid, DOT4

You should never allow the brake fluid level to drop below the **MIN** mark. (Brake-fluid reservoir horizontal)

If the brake fluid level drops below the permitted level:

- Have the defect rectified as quickly as possible by a specialist workshop, preferably an authorised BMW Motorrad dealer.

Checking the brake-fluid level, rear brakes

- Make sure the ground is level and firm and hold the motorcycle upright.



- Check the brake fluid level in brake fluid reservoir **1**.

NOTICE

Wear of the brake pads causes the brake fluid level in the reservoir to sink. ◀



Brake fluid level, rear

Brake fluid, DOT4

You should never allow the brake fluid level to drop below the **MIN** mark. (Brake-fluid reservoir horizontal)

If the brake fluid level drops below the permitted level:

WARNING

Not enough brake fluid in brake fluid reservoir

Considerably reduced braking power due to air in the brake system

- Check the brake-fluid level at regular intervals.◀
- Have the defect rectified as quickly as possible by a specialist workshop, preferably an authorised BMW Motorrad dealer.

Clutch

Checking clutch function

- Pull the clutch lever.
 - » The clutch must fully disengage. Signs that the clutch is fully disengaged:
 - Easy to change gear
 - Easy to switch to idling

If this is not the case, or there is a lack of power transmission after the clutch has engaged:

- Have the clutch checked by a specialist workshop, preferably an authorised BMW Motorrad dealer.

Checking clutch-lever play

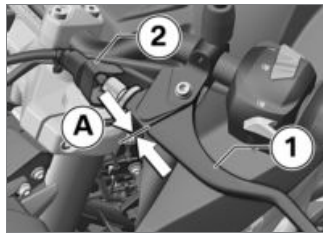

- Loosen cover **2**.
- Pull clutch lever **1** until resistance is perceptible.

- In this position, measure the clutch-lever play **A** between the clutch-lever fitting and the clutch lever.



Clutch-lever play

1...2 mm (at the hand lever, handlebars are in straight-ahead position, engine is cold)

Clutch-lever play is out of tolerance:

- Adjust the clutch-lever play (► 74).

Clutch-lever play is in tolerance:

- Install cover **2**.

Adjust the clutch-lever play

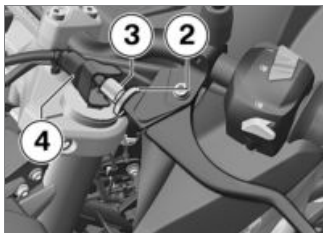

- Loosen cover **4**.
- Loosen the knurled nut **2**.
- Lift the clutch cable to relieve the adjusting sleeve **3**.
- To increase clutch-lever play: screw the adjusting sleeve **3** into the hand lever.
- To reduce clutch-lever play: unscrew the adjusting sleeve **3** from the hand lever.
- Lock the adjusting sleeve **3** using the knurled nut **2**.
- Checking clutch-lever play (▮▮▮ 73).

- Repeat the steps until the clutch-lever play is set correctly.
- Install cover **4**.

Coolant

Check coolant level Requirement

The engine is cold.

- Hold the motorcycle upright, ideally with help from another person.

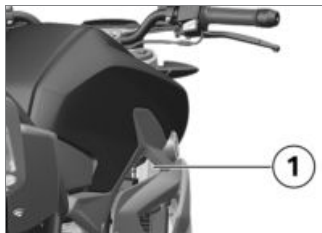

- Check the coolant level in the coolant expansion tank **1**.
Viewing direction: from the rear

toward the inside of the right side trim panel.

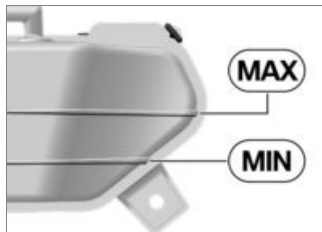

Coolant, specified level

Between **MIN** and **MAX** marks on the expansion tank (Engine is cold, motorcycle is upright)

If the coolant drops below the permitted level:

- Top up coolant (▮▮▮ 75).

Top up coolant



- Turn the handlebars all the way to left.
- Open the cap **1** of the coolant expansion tank.
- Top up coolant to specified level. Use a funnel with filler adapter or hose.



Coolant-full quantity

Antifreeze and corrosion inhibitor

150 ml (Difference between **MIN**- and **MAX**-mark)

- Check coolant level (➡ 74). When the coolant meets the specified level:
- Close the cap of the coolant expansion tank.

Wheel rims and tyres

Checking rims

- Make sure the ground is level and firm and place the motorcycle on its stand.
- Visually inspect the rims for defects.
- Have any damaged rims inspected by a specialist workshop and replaced if necessary, preferably by an authorised BMW Motorrad dealer.

Checking tyre tread depth



WARNING

Riding with badly worn tyres

Risk of accident due to impaired handling

- If applicable, have the tyres changed in good time before they wear to the minimum tread depth permitted by law. ◀
- Make sure the ground is level and firm and place the motorcycle on its stand.
- Measure the tyre tread depth in the main tread grooves with wear marks.



NOTICE

Wear indicators are built into the main profile grooves on each tyre. The tyre is worn out when the tyre tread has worn down to the level of the marks. The locations of the marks are indicated on the edge of the tyre, e.g. by the letters TI, TWI or by an arrow. ◀

If the tyre tread is worn to minimum:

- Replace tyre or tyres, as applicable.

Checking tyre pressure



WARNING

Incorrect tyre pressure

Impaired handling characteristics of the motorcycle, shorter useful tyre life

- Always check that the tyre pressures are correct. ◀



WARNING

Tendency of valve inserts to open by themselves at high riding speeds

Sudden loss of tyre pressure

- Install valve caps fitted with rubber sealing rings and tighten firmly. ◀
- Make sure the ground is level and firm and place the motorcycle on its stand.

- Check tyre pressures against the data below.



Tyre pressure, front

2.2 bar (with cold tyres; one-up and two-up riding)



Tyre pressure, rear

2.3 bar (with cold tyres; one-up and two-up riding)

If tyre pressure is too low:

- Correct tyre pressure.

Wheels

Effect of wheel size on chassis and suspension control systems

The wheel sizes are very important for the ABS. In particular, the diameter and the width of the vehicle's wheels are programmed into the control unit

and are fundamental to all calculations. Any change to these dimensions, caused for example by a switch to wheels other than the standard installed ones, can seriously affect the performance of the control systems.

The sensor rings are essential for correct wheel speed detection; they too must match the motorcycle's control systems and consequently cannot be replaced. If you decide that you would like to fit non-standard wheels to your motorcycle, it is very important to consult a specialist workshop beforehand, preferably an authorised BMW Motorrad dealer.

Removing front wheel

– with centre stand^{OA}

- Make sure the ground is level and firm and place the motorcycle on its centre stand. ◀

- without centre stand^{OA}
- Place the motorcycle on an auxiliary stand. BMW Motorrad recommends you use the BMW Motorrad rear-wheel stand.
- Install the rear-wheel stand (► 66).◀
- Lift the front of the motorcycle until the front wheel is clear of the ground, preferably using a BMW Motorrad front-wheel stand.
- Installing the front-wheel stand (► 65).
- Mask off the parts of the wheel rim that could be scratched when removing the brake caliper.
- Push apart the brake pads a little.



- Slacken clamping screws **1**.

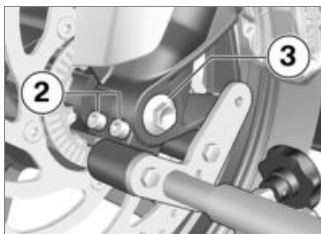

- Remove screw **3**.
- Slacken clamping screws **2**.
- Press quick-release axle slightly toward the inside, so as to be

better able to grip it on the right-hand side.

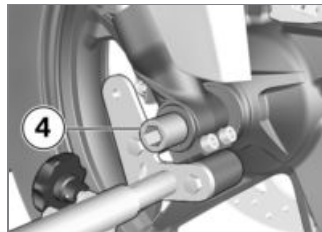

- Withdraw quick-release axle **4**, support the front wheel when doing this.
- Set down front wheel and roll forwards out of the front suspension. Ensure you do not damage the wheel speed sensor in the process.



ATTENTION

Unwanted inward movement of the brake pads

Component damage on attempt to install the brake caliper or because brake pads have to be forced apart

- Do not operate the brakes with a brake caliper not correctly secured.◀
- Remove spacer bush **5** from the wheel hub.

Installing front wheel



WARNING

Use of a non-standard wheel

Malfunctions in ABS operation

- See the information on the effect of wheel size on the ABS system at the start of this chapter.◀



ATTENTION

Tightening threaded fasteners to incorrect tightening torque

Damage, or threaded fasteners work loose

- Always have the security of the fasteners checked by a specialist workshop, preferably an authorised BMW Motorrad dealer.◀



- Slip spacing bushing **5** into the wheel hub on the left-hand side.



ATTENTION

Front wheel installed wrong way round

Risk of accident

- Note direction-of-rotation arrows on tyre or rim.◀
- Roll the front wheel into position between the front forks. In this process, take care not to damage the wheel speed sensor.



- Lift front wheel and fit quick-release axle **4**.
- Remove front-wheel stand and firmly compress front forks several times. Do not operate the brake lever in this process.
- Installing the front-wheel stand (▶▶▶ 65).

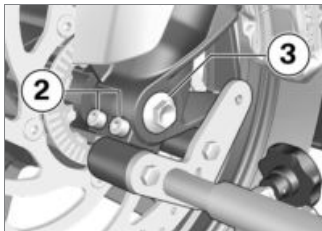

- Install screw **3** and tighten to specified torque. Counter-hold quick-release axle on the right-hand side.

	Screw in front-wheel quick-release axle
50 Nm	

- Tighten clamping bolts **2** to the specified tightening torque.



	Clamping screws in axle holder
Tightening sequence: Tighten screws six times in alternate sequence	
19 Nm	



- Tighten clamping bolts **1** to the specified tightening torque.



Clamping screws in axle holder

Tightening sequence: Tighten screws six times in alternate sequence

19 Nm

- Removing the front-wheel stand.
- Remove the adhesive tape from the wheel rim.



WARNING

Brake pads not lying against the brake disc

Risk of accident due to delayed braking effect.

- Before driving, check that the brakes respond without delay.◀
- Operate the brake several times until the brake pads are bedded.

Removing rear wheel

- with centre stand^{OA}
- Make sure the ground is level and firm and place the motorcycle on its centre stand.◁
- without centre stand^{OA}
- Lift the motorcycle, preferably with a BMW Motorrad rear-wheel stand.
- Install the rear-wheel stand (▶▶ 66).◁
- Slip wooden chocks or similar under the rear wheel to prevent it from dropping out after the

quick-release axle has been removed.

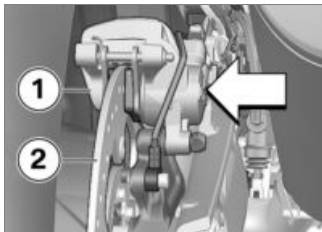

- Press brake caliper **1** against brake disc **2**.
- » Brake piston has been pushed back.

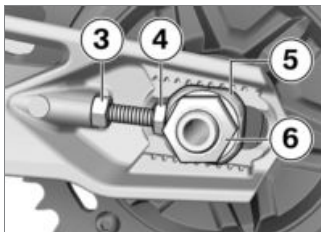

- Remove nut **6** using the right tool from the toolkit.
- Remove washer.
- Slacken locknuts **3** on left and right.
- Screw in the adjusting screws **4** on the left and right.
- Remove the chain tensioner **5** and push the quick-release axle to the right as far as it will go.

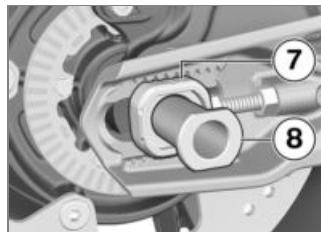

- Remove the quick-release axle **8** and remove the chain tensioner **7**.

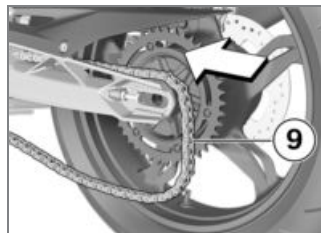

- Roll the rear wheel as far forward as possible and

disengage chain **9** from the sprocket.

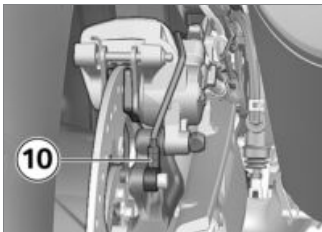

- When rolling the rear wheel clear of the motorcycle, take care not to damage wheel-speed sensor **10**.

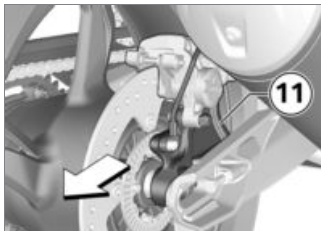

- Roll the rear wheel to the rear and clear of the swinging arm and at the same time pull brake-caliper carrier **11** back far enough to allow the rear wheel to clear it.



NOTICE

The sprocket and the spacer sleeves on left and right are loose fits in the wheel. When removing, make sure that no parts are damaged or mislaid.◀

Installing the rear wheel



ATTENTION

Tightening threaded fasteners to incorrect tightening torque

Damage, or threaded fasteners work loose

- Always have the security of the fasteners checked by a specialist workshop, preferably an authorised BMW Motorrad dealer.◀
- Roll the rear wheel on the support into the swinging arm as far as necessary to permit the brake-caliper carrier to be inserted.

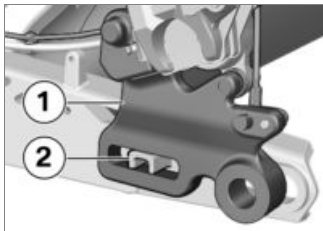

- Position the brake-caliper support **1** on the guide **2**.

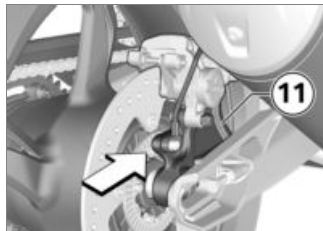

- Roll the rear wheel further into the swinging arm, while pushing brake-caliper carrier **11** forward at the same time.

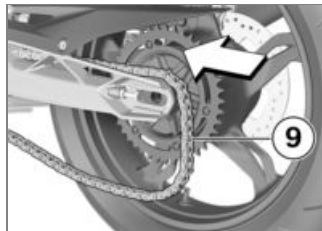

- Roll the rear wheel as far forward as possible and loop chain **9** over the sprocket.

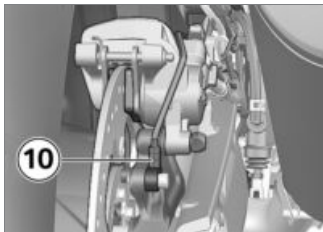

- When rolling the rear wheel into position, take care not to damage wheel-speed sensor **10**.

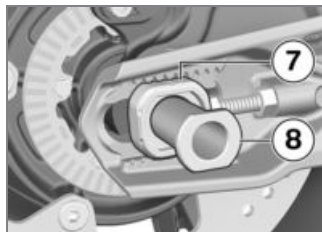

- Insert the quick-release axle **8** and the chain tensioner **7** into the swinging arm, brake-caliper support and rear wheel, mak-

ing sure that you fit the quick-release axle securely into the chain tensioner.

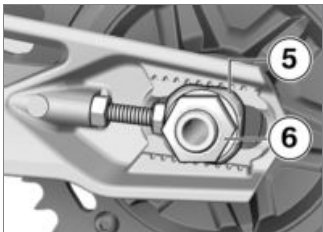

- Insert the left chain tensioner **5**.
- Install nut **6** with its washer, but do not tighten the nut at this point.
- Adjust the chain tension (▣▣▣ 84).

Chain

Adjust the chain tension

- Make sure the ground is level and firm and place the motorcycle on its stand.

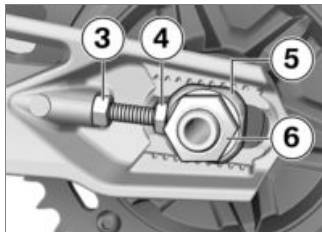

- Slacken nut **6**.
- Slacken locknuts **3** on left and right.
- Use adjusting screws **4** on left and right to adjust chain tension.
- Checking chain tension (▣▣▣ 84).
- Ensure that the notch in the chain tensioner **5** is adjusted

to the same scale value on the right and left.

- Tighten locknuts **3** on left and right to the specified tightening torque.



Locknut of the final-drive chain tensioning screw

19 Nm

- Tighten nut **6** to the specified tightening torque.



Rear quick-release axle in swinging arm

100 Nm

- Once you have tightened the rear wheel quick-release axle, complete the following tasks again:
 - Checking chain tension (▣▣▣ 84).

Checking chain tension

- Make sure the ground is level and firm and place the motorcycle on its stand.

- Turn the rear wheel until it reaches the position with the lowest amount of chain sag.

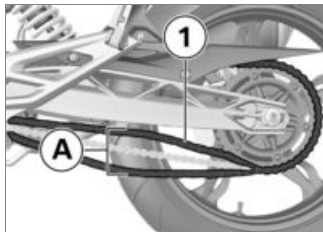

- Use a screwdriver to push the chain **1** up and down at a point midway between the pinion and chain sprocket and measure the chain tension **A**.

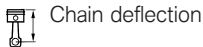

Chain deflection

40...50 mm (Motorcycle with no weight applied, supported on its side stand)

If chain deflection is outside permitted tolerance:

- Adjust the chain tension (→ 84).

Lubricating chain



ATTENTION

Inadequate cleaning and lubrication of the drive chain

Accelerated wear

- Clean and lubricate the drive chain at regular intervals.◀
- Lubricate the drive chain every third fuel stop.
- Lubricate the chain more frequently if the motorcycle is ridden in wet, dusty or dirty conditions.
- Switch the ignition off and select neutral.
- Clean the drive chain with a suitable cleaning product, dry it and apply chain lubricant.

- To prolong chain life, BMW Motorrad recommends the use of BMW Motorrad chain lubricant, or:



Lubricant

Chain spray

- Wipe off excess lubricant.

Checking the chain wear

- Engage 1st gear.
- Turn the rear wheel in the normal direction of travel until the chain is tensioned.
- Measure chain length underneath the rear wheel swinging arm.

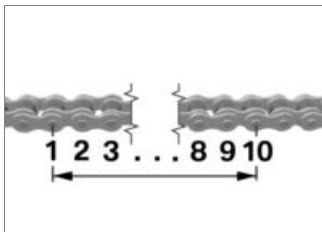

Permissible chain length

max 144.30 mm (measured
centre to centre over 10
pins, chain pulled taut)

If the chain has stretched to the maximum permissible length:

- Seek the advice of a specialist workshop, preferably an authorised BMW Motorrad dealer.

Light source

Opening the front mask

- Place the motorcycle on its stand on firm, even ground.
- Switch off the ignition.



- Remove the bolts **1** on either side.
- Pull the front mask **2** forward.

Replacing bulbs for low-beam headlight and high-beam headlight

- Open the front mask (→ 86).

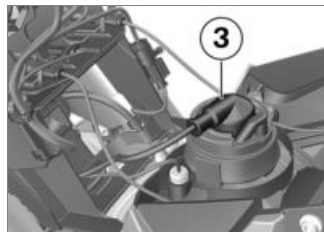

- Pull out plug **3**.

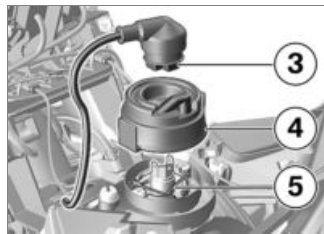

- Remove cover **4**.
- Disengage the wire spring clip **5** from the stop and fold up.



- Remove the bulb **6** from the socket **7**.
- Replace the defective bulb.

NOTICE

Bulbs with higher light-intensity ratings are available through aftermarket suppliers. These bulbs burn out more rapidly and generate more heat than conventional bulbs. Under adverse conditions the extra heat can cause damage to the headlight. ◀



Bulb for low-beam and high-beam headlight

H4 / 12 V / 60 W / 55 W

- To avoid soiling the glass, touch the bulb **6** only at the base.



- Position the bulb **6** and press it into the socket **7**.
- Install the wire spring clip **5**.

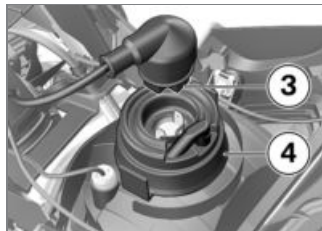

- Install cover **4**.
- Connect plug **3**.
- Close the front mask (▶▶▶ 88).

Replacing bulb for parking light

- Open the front mask (▶▶▶ 86).

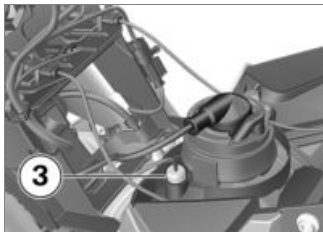

- Pull the socket **3** out of the headlight housing.

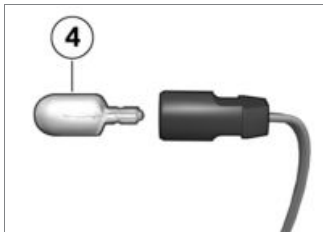

- Remove bulb **4** from the socket.

- Replace the defective bulb.



Bulb for parking light

W5W / 12 V / 5 W

- Use a clean, dry cloth to hold the bulb in order to keep the glass free of foreign matter.

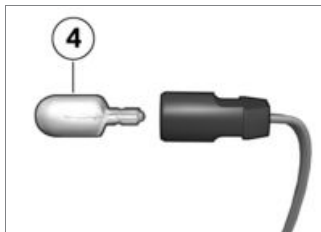

- Insert bulb **4** into the socket.

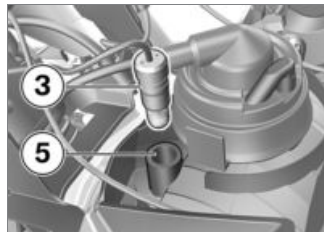

- Fit the socket **3** into the headlight housing **5**.
- Close the front mask (▶▶ 88).

Closing the front mask

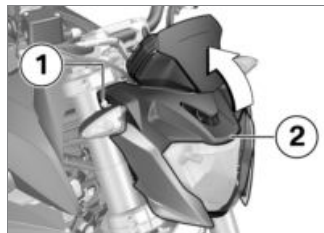

- Close the front mask **2**.
- Fit the screws **1** on either side.

Replacing bulbs for front and rear turn indicators

- Make sure the ground is level and firm and place the motorcycle on its stand.
- Switch off the ignition.



- Remove screw **1**.



- Pull the glass out of the light housing at the threaded-fastener side.

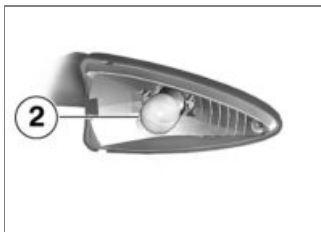

- Turn bulb **2** counter-clockwise and remove it from the light housing.

- Replace the defective bulb.

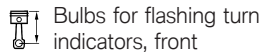

RY10W / 12 V / 10 W

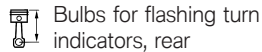

RY10W / 12 V / 10 W

- Use a clean, dry cloth to hold the bulb in order to keep the glass free of dirt and foreign matter.

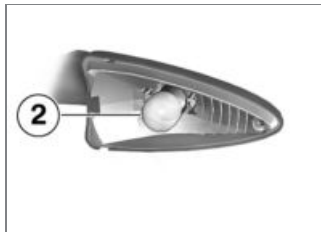

- Turn bulb **2** clockwise to install it in the bulb housing.



- Working from the inboard side, insert the glass into the light housing and close the housing.



- Install screw **1**.

Replacing LED turn indicators

– with LED flashing turn indicators^{OA}

If the LED flashing turn indicators fail, they must be replaced. Under these circumstances:

- Seek the advice of a specialist workshop, preferably an authorised BMW Motorrad dealer.

Replacing LED rear light

If the LEDs in the rear light fail, the rear light must be replaced. Under these circumstances:

- Seek the advice of a specialist workshop, preferably an authorised BMW Motorrad dealer.

Replacing number-plate light

If the LEDs for the number plate light in the rear light fail, the rear light must be replaced. Under these circumstances:

- Seek the advice of a specialist workshop, preferably an authorised BMW Motorrad dealer.

Jump-starting



CAUTION

Touching live parts of the ignition system when the engine is running

Electric shock

- Do not touch parts of the ignition system when the engine is running.◀



ATTENTION

Excessive current flowing when the motorcycle is jump-started

Wiring smoulders/ignites or damage to the on-board electronics

- If the motorcycle has to be jump-started connect the leads to the battery terminals; never attempt to jump-start the en-

gine by connecting leads to the on-board socket. ◀



ATTENTION

Contact between crocodile clips of jump leads and vehicle

Risk of short-circuit

- Use jump leads fitted with fully insulated crocodile clips at both ends. ◀



ATTENTION

Jump-starting with a voltage greater than 12 V

Damage to the on-board electronics

- Make sure that the battery of the donor vehicle does not exceed a voltage of 12 V. ◀
- When jump-starting the engine, do not disconnect the battery from the on-board electrical system.

- Remove seat (▶▶▶ 38).
- Run the engine of the donor vehicle during jump-starting.
- Begin by connecting one end of the red jump lead to the positive terminal of the discharged battery and the other end to the positive terminal of the donor battery.
- Then connect one end of the black jump lead to the negative terminal of the donor battery, and the other end to the negative terminal of the discharged battery.
- Start the engine of the vehicle with the discharged battery in the usual way; if the engine does not start, wait a few minutes before repeating the attempt in order to protect the starter motor and the donor battery.
- Allow both engines to run for a few minutes before disconnecting the jump leads.

- Disconnect the jump lead from the negative terminal first, then disconnect the second lead from the positive terminal.
- Installing the seat (▶▶▶ 39).

Battery

Maintenance instructions

Correct upkeep, recharging and storage will prolong the life of the battery and are essential if warranty claims are to be considered.

Compliance with the points below is important in order to maximise battery life:

- Keep the surface of the battery clean and dry.
- Do not open the battery.
- Do not top up with water.
- Be sure to read and comply with the instructions for charging the battery on the following pages.

- Do not turn the battery upside down.



ATTENTION

On-board electronics (e.g. clock) draining connected battery

Battery is deep-discharged; this voids the guarantee

- Connect a float charger to the battery if the motorcycle is to remain out of use for more than four weeks.◀



NOTICE

BMW Motorrad has developed a float charger specially designed for compatibility with the electronics of your motorcycle. Using this charger, you can keep the battery charged during long periods of disuse, without having to disconnect the battery from the motorcycle's on-board sys-

tems. You can obtain additional information from your authorised BMW Motorrad dealer.◀

Recharging connected battery



ATTENTION

Charging the battery that is connected to the vehicle via the battery terminals

Damage to the on-board electronics

- Disconnect the battery at the battery terminals before charging.◀
- Disconnecting battery from motorcycle (▣▣▣ 92).

Recharging disconnected battery

- Disconnecting battery from motorcycle (▣▣▣ 92).
- charge the battery using a suitable charger.

- Comply with the operating instructions of the charger.
- Once the battery is fully charged, disconnect the charger's terminal clips from the battery terminals.



NOTICE

The battery has to be recharged at regular intervals in the course of a lengthy period of disuse. See the instructions for caring for your battery. Always fully recharge the battery before restoring it to use.◀

- Connecting battery to motorcycle (▣▣▣ 93).

Disconnecting battery from motorcycle

- Make sure the ground is level and firm and place the motorcycle on its stand.
- Remove seat (▣▣▣ 38).

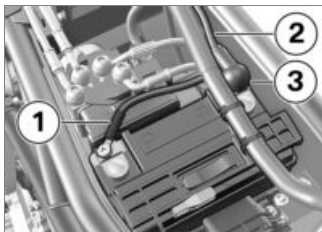

Connecting battery to motorcycle

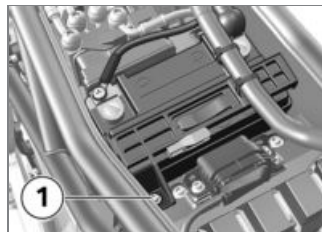
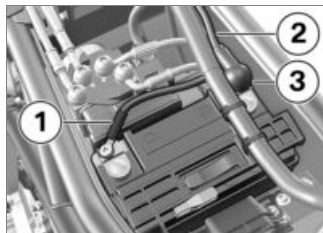

ATTENTION

Battery not disconnected in accordance with correct procedure

Risk of short-circuit

- Always proceed in compliance with the specified disconnection sequence. ◀
- Disconnect the battery earth lead **1** first.
- Then push the protective cap **3** to the side and disconnect the positive battery cable **2**.

- First install the positive battery cable **2** and cover with the protective cap **3**.
- Then install battery negative lead **1**.
- Installing the seat (➡ 39).

Removing battery

- Remove seat (➡ 38).
- Disconnecting battery from motorcycle (➡ 92).

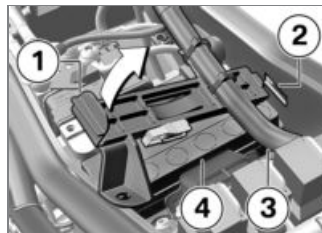

- Remove screw **1**.

- Unhook and lift up the holder **1** on the left.
- Unloosen the holder from the battery tray **2** on the right.

- » The holder is now only attached to the wiring harness **3**.
- Push the holder and the wiring harness to the right out of the way.
- » You can now remove the battery.
- Lift the battery **4** up and out. Work it back and forth slightly if it is difficult to remove.

Installing battery

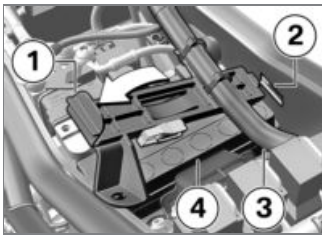

- Place the battery **4** in the battery compartment with the positive terminal on the right in the direction of travel.

- Attach the right side of the holder to the battery tray **2**.
- Fold the holder **1** down and attach on the left.
- » The wiring harness **3** is now back in its initial position.

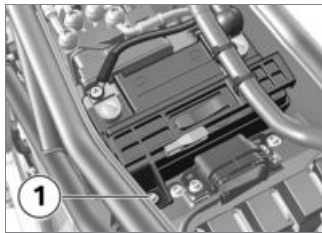

- Install screw **1**.
- Connecting battery to motorcycle (▶▶▶ 93).
- Installing the seat (▶▶▶ 39).

NOTICE

If the battery was disconnected from the motorcycle for a prolonged period of time it

will be necessary to enter the current date in the instrument panel, in order to ensure that the service-due indicator functions correctly.◀

- Setting the date (▶▶▶ 37).

Fuses

Replace fuses

ATTENTION

Jumpering of blown fuses

Risk of short-circuit and fire

- Never attempt to jumper a blown fuse.
- Always replace a defective fuse with a new fuse of the same amperage.◀
- Switch off the ignition.
- Place the motorcycle on its stand on firm, even ground.
- Remove seat (▶▶▶ 38).

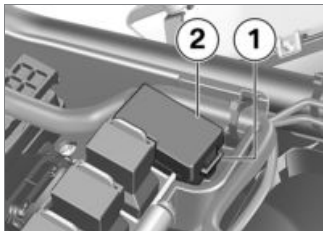

- Press latch **1**.
- Open the fuse box **2**.
- Consult the fuse assignment diagram below and replace the defective fuse.
- » Fuse assignment (➡ 95)
- Close the fuse box **2** again. Make sure that the lock **1** has engaged.

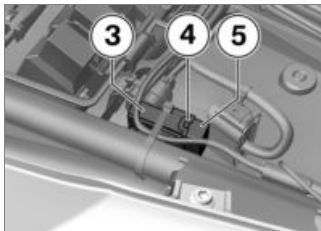

- Press the lock **4** in on both sides.
- Remove cap **5**.
- Consult the fuse assignment diagram below and replace the defective fuse.
- » Fuse assignment (➡ 95)
- Install cap **5**. Make sure that the lock **4** on the fuse box **3** engages.



NOTICE

If fuse defects recur frequently have the electric circuits checked by a specialist workshop,

preferably an authorised BMW Motorrad dealer. ◀

- Installing the seat (➡ 39).

Fuse assignment

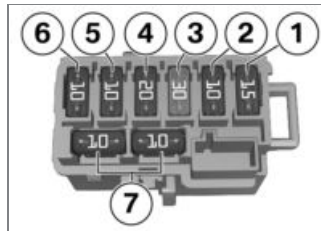

7.5 A (Oxygen sensor, tank vent valve, secondary air system, injection system, electric fuel pump)



Fuse 2

7.5 A (Heated grips, engine control unit, ABS pressure modulator, diagnostic connector, extra socket)



Fuse 3

30 A (Main fuse)



Fuse 4

20 A (ABS pressure modulator)



Fuse 5

15 A (Lighting, horn)



Fuse 6

10 A (Instrument cluster, engine control unit)

– Reserve fuses **7**

Fuse **8** for radiator fan

Fuse for radiator fan

7.5 A (Radiator fan)

Diagnostic connector Disengaging diagnostic connector



CAUTION

Incorrect procedure followed when loosening the diagnostic connector for the on-board diagnosis

Motorcycle experiences malfunctions

- Only have the diagnostic connector loosened by a specialist workshop or other authorised persons during your next BMW Service appointment.
- Have the work performed by appropriately trained staff.
- Refer to the vehicle manufacturer specifications. ◀
- Remove seat (►► 38).

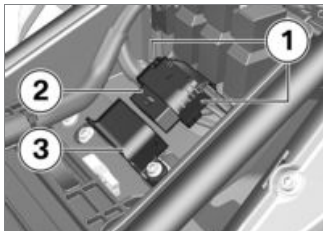

- Press in retainers **1**.
- Disengage diagnostic connector **2** from holder **3**.
 - » The interface to the diagnosis and information system can be connected to diagnostic connector **2**.

Securing the diagnostic connector

- Disconnect the interface for the diagnosis and information system.

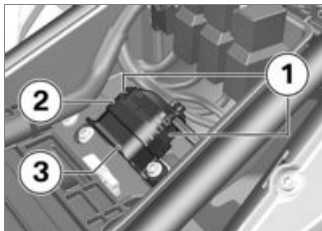

- Seat diagnostic connector **2** in bracket **3**.
 - » Retainers **1** engage with an audible click.
- Installing the seat (→ 39).

Accessories

General instructions.....	100
Heated handlebar grips	100
Power socket	101
Topcase	101
TopcaseLight	104
Maximum payload and maximum permissible speed	105

General instructions

CAUTION

Use of other-make products

Safety risk

- BMW Motorrad cannot examine or test each product of outside origin to ensure that it can be used on or in connection with BMW vehicles without constituting a safety hazard. Country-specific official authorisation does not suffice as assurance. Tests conducted by these instances cannot make provision for all operating conditions experienced by BMW vehicles and, consequently, they are not sufficient in some circumstances.
- Use only parts and accessories approved by BMW for your vehicle. ◀

BMW has conducted extensive testing of the parts and ac-

cessory products to establish that they are safe, functional and suitable. Consequently, BMW accepts product liability. BMW accepts no liability whatsoever for parts and accessories that it has not approved.

Whenever you are planning modifications, comply with all the legal requirements. Make sure that the vehicle does not infringe the national road-vehicle construction and use regulations applicable in your country.

Your BMW Motorrad dealer can offer expert advice on the choice of genuine BMW parts, accessories and other products. To find out more about accessories go to:

**[bmw-motorrad.com/
accessories](http://bmw-motorrad.com/accessories)**

Heated handlebar grips

– with heated grips^{OA}

Operating the heated handlebar grips

- Start the engine.

NOTICE

The heating in the heated handlebar grips can be activated only when the engine is running. ◀

NOTICE

The increase in power consumption caused by having the heated handlebar grips switched on can drain the battery if you are riding at low engine speeds. ◀

NOTICE

The handlebar grips have two-stage heating. Stage two is for heating the grips quickly: it is

advisable to switch to stage one as soon as the grips are warm.◀



- Press the rocker switch **1** on the side with the two dots to switch the high heat setting on.
- Press the rocker switch **1** on the side with one dot to switch the low heat setting on.
- Set the rocker switch **1** to the centre position to switch the heating off.

Power socket

- with extra socket^{OA}

Connection of electrical devices

- You can start using electrical devices connected to the motorcycle's sockets only when the ignition is switched on.

Cable routing

- The cables from the power sockets to the auxiliary devices must be routed in such a way that they do not impede the rider.
- The cable routing should not restrict the steering angle or obstruct handling.
- The cables must not be trapped.

Topcase

- with luggage carrier^{OA}
- with topcase^{OA}

Installing topcase



WARNING

Topcase not properly secured

Driving safety is impaired

- The topcase must not wobble and must be secured free from play.◀



- Pull handle **1** up as far as it will go.

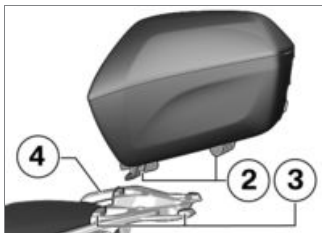

- Hook the topcase into the luggage carrier **4**. Make sure that the hooks **2** fit securely into the corresponding mountings **3**.
- Push handle **1** down until it engages.



- Turn the key in the topcase lock to position **1** and remove the key from the lock.

Opening topcase



- Turn the key in the topcase lock to position **1**.



- Push lock barrel **1** forward.
 - » Lever **2** pops up.
- Pull the release lever all the way up.
 - » The lid of the topcase opens.

Closing topcase



- Pull release lever **1** all the way up.
- Close the lid of the topcase and hold it down. Check that nothing is trapped between the lid and the case.



NOTICE

You can also lock the topcase by turning the lock to the **LOCK** position. In this case, make sure that the key is not left inside the topcase. ◀



- Push release lever **1** down until it engages.
- Turn the key in the topcase lock to the **LOCK** position and remove the key from the lock.

Removing the topcase



- Turn the key in the topcase lock to position **1**.
» The handle pops out.



- Pull handle **1** up as far as it will go.

- Lift the topcase at the rear and remove it from the luggage carrier.

TopcaseLight

- with luggage carrier^{OA}
- with topcase Light^{OA}

Installing topcase Light



WARNING

Topcase not properly secured

Driving safety is impaired

- The topcase must not wobble and must be secured free from play. ◀
- Turn the key until it is vertical in the lock.



- Insert the base **5** into the slot **4**.
- Fit the mounting **6** onto the hook **2**.
- Ensure that the release lever **1** engages and the topcase is connected securely to the adapter **3**.
- To lock the release lever, turn the key until it is horizontal in the lock and pull it out.

Opening topcase Light

- Turn the key until it is vertical in the lock.



NOTICE

When the key is horizontal in the lock, the release levers are locked. ◀

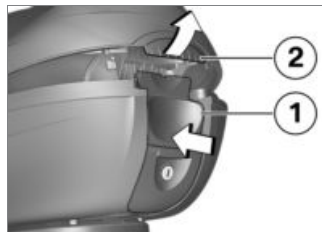

- Push the release lever **1** in the direction of the arrow.
- Open the topcase lid **2**.

Closing topcase Light

- Turn the key until it is vertical in the lock.

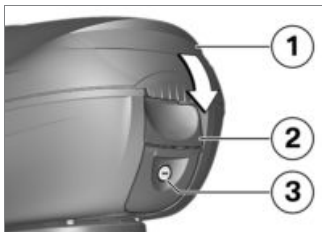

- Close the topcase lid **1**. Check that nothing is trapped between the lid and case and that the release lever **2** clicks into place.
- Turn the key in the topcase lock **3** until it is horizontal and remove the key from the lock.
 - » The release levers are locked. You can neither open the topcase nor remove it from the adapter.

Removing the topcase Light

- Turn the key until it is vertical in the lock.





- Push the release lever **1** in the direction of the arrow.
- Lift the topcase at the rear and remove from the adapter **3**.

Maximum payload and maximum permissible speed

Note the maximum permissible payload and the speed limit for riding with topcase fitted, as stated on the label inside the topcase.

Contact your authorised BMW Motorrad dealer if you

cannot find your combination of vehicle and topcase on the label. The values for the combination described here are as follows:

	Maximum permissible speed for riding with topcase fitted to the vehicle
	– with topcase ^{OA} or – with topcase Light ^{OA}
	max 130 km/h<
	Payload of topcase
	– with topcase ^{OA} or – with topcase Light ^{OA}
	max 3 kg<

Care

Care products	108
Washing the vehicle	108
Cleaning easily damaged components.....	109
Paint	110
Preserving paintwork.....	110
Laying up the motorcycle	110
Restoring motorcycle to use	110

Care products

BMW Motorrad recommends that you use the cleaning and care products you can obtain from your authorised BMW Motorrad dealer. The substances in BMW CareProducts have been tested in laboratories and in practice; they provide optimised care and protection for the materials used in your vehicle.

ATTENTION

Use of unsuitable cleaning and care products

Damage to vehicle parts

- Do not use solvents such as cellulose thinners, cold cleaners, fuel or the like, and do not use cleaning products that contain alcohol. ◀

Washing the vehicle

BMW Motorrad recommends that you use BMW insect remover to soften and wash off insects and stubborn dirt on painted parts prior to washing the motorcycle.

To prevent stains, do not wash the vehicle immediately after it has been exposed to strong sunlight and do not wash it in the sun.

To remove road salt, clean the motorcycle with cold water immediately after every trip.

WARNING

Wet brake discs and brake pads after vehicle wash, after riding through water and in rainy conditions

Diminished braking effect, risk of accident

- Apply the brakes in good time to allow the friction and heat to

dry the brake discs and brake pads. ◀

ATTENTION

Effect of road salt intensified by warm water

Corrosion

- Use only cold water to wash off road salt. ◀

ATTENTION

Damage due to high water pressure from high pressure cleaners or steam cleaners

Corrosion or short circuit, damage to labels, seals, hydraulic brake system, electrical system and the motorcycle seat

- Exercise restraint when using a steam jet or high pressure cleaning equipment. ◀

Cleaning easily damaged components

Plastics

ATTENTION

Use of unsuitable cleaning agents

Damage to plastic surfaces

- Do not use cleaning agents that contain alcohol, solvents or abrasives.
- Do not use insect-remover pads or cleaning pads with hard, scouring surfaces.◀

Body panels

Clean the trim panels with water and BMW plastic care emulsion.

NOTICE

Soften stubborn dirt and insects by covering the affected areas with a wet cloth.◀

Light topcase

ATTENTION

Use of unsuitable cleaning and care products

Damage to the surface

- Clean the surface using only water and a microfibre cloth.◀

Chrome

Clean chrome sections carefully with plenty of water and motorcycle cleaner from the BMW Motorrad Care Products range. This is required in particular for removing road salt.

Use chrome polish for additional treatment.

Radiator

ATTENTION

Bending of radiator fins

Damage to radiator fins

- Take care not to bend the radiator fins when cleaning.◀
- Clean radiator regularly. Use a hose with low water pressure, for example, to do this.
 - » This prevents the engine from overheating due to insufficient cooling.

Rubber

Treat rubber components with water or BMW rubber-care products.

ATTENTION

Application of silicone sprays to rubber seals

Damage to the rubber seals

- Do not use silicone sprays or care products that contain silicon.◀

Paint

Washing the vehicle regularly will help counteract the long-term effects of substances that damage the paint, especially if your vehicle is ridden in areas with high air pollution or natural sources of dirt, for example tree resin or pollen.

Remove particularly aggressive substances immediately, however, as otherwise the paint can be affected or become discoloured. Substances of this nature include spilt fuel, oil, grease, brake fluid and bird droppings. We recommend you use BMW Motorrad gloss polish or BMW paint cleaner.

Marks on the paintwork are particularly easy to see after the vehicle has been washed. Remove stains of this kind immediately, using cleaning-grade benzene or petroleum spirit on a clean cloth or ball of cotton wool.

BMW Motorrad recommends using BMW tar remover for removing specks of tar. Remember to wax the parts treated in this way.

Preserving paintwork

BMW Motorrad recommends applying only BMW car wax or products containing carnauba wax or synthetic wax to preserve the paintwork.

It is time to rewax the paintwork when water "puddles" on the surface, instead of forming beads.

Laying up the motorcycle

- Clean the motorcycle.
- Fill the motorcycle's fuel tank.
- Removing battery (🔗 93).

- Spray the brake and clutch lever pivots and the main and side stand pivots with a suitable lubricant.
- Coat bright metal and chrome-plated parts with an acid-free grease (e.g. Vaseline).
- Stand the motorcycle in a dry room in such a way that there is no load on either wheel (preferably using the front-wheel and rear-wheel stands from BMW Motorrad).

Restoring motorcycle to use

- Remove the protective wax coating.
- Clean the motorcycle.
- Installing battery (🔗 94).
- Comply with checklist (🔗 48).

Technical data

Troubleshooting chart	112
Screw connections	113
Fuel.....	115
Engine oil	115
Engine	116
Clutch	117
Transmission	117
Rear-wheel drive.....	118
Frame	118
Chassis and suspension	119
Brakes	119
Wheels and tyres	120
Electrical system.....	122
Dimensions	123
Weights.....	124

Riding specifications	124
Accessories.....	124

Troubleshooting chart

The engine does not start.

Possible cause	Rectification
Side stand extended and gear engaged	Retract the side stand.
Kill switch activated	Set emergency-off switch to operation mode (▣▣▣▶ 33).
Gear engaged and clutch not disengaged	Operate the clutch or put the transmission into idle so that the idle mode indicator light lights up.
No fuel in tank	Refuelling (▣▣▣▶ 55).
Battery flat	Recharging connected battery (▣▣▣▶ 92).
Throttle grip operated	Do not operate throttle grip during starting operation.

Screw connections

Front wheel	Value	Valid
Screw in front-wheel quick-release axle		
M12 x 20	50 Nm	
Clamping screws in axle holder		
M8 x 30	Tighten screws six times in alternate sequence	
	19 Nm	
Rear wheel	Value	Valid
Locknut of the final-drive chain tensioning screw		
M8	19 Nm	
Rear quick-release axle in swinging arm		
M18 x 1.5	100 Nm	

Mirrors	Value	Valid
Right mirror (lock nut) to adapter		
M10 x 1.25	Left-hand thread, 22 Nm	
Left mirror (lock nut) to adapter		
M10 x 1.25	22 Nm	

Fuel

Recommended fuel grade	Regular, unleaded (max. 10 % ethanol, E10) 91 ROZ/RON 87 AKI
Usable fuel capacity	approx. 11 l
Fuel reserve	approx. 1 l
Fuel consumption according to WMTC	3.3 l/100 km

Engine oil

Engine oil, capacity	approx. 1.65 l, with filter change
Viscosity class	
SAE 15W-50, API SJ / JASO MA2	Additives (e.g. molybdenum-based) are not permissible because they can attack coated components of the engine, BMW Motorrad recommends BMW Motorrad ADVANTEC Pro oil.
Engine oil, quantity for topping up	max 185 ml, Difference between MIN and MAX

BMW recommends **ADVANTEC**
ORIGINAL BMW ENGINE OIL

Engine

Location of engine number	Crankcase, lower part, right
Engine type	A82A03A
Engine design	Water-cooled, 1-cylinder, four-stroke engine with four valves that are actuated via rocker arms, two overhead camshafts and a counterbalance shaft
Displacement	313 cm ³
Cylinder bore	80 mm
Piston stroke	62.1 mm
Compression ratio	10.6:1
Nominal output	25 kW, at engine speed: 9500 min ⁻¹
Torque	28 Nm, at engine speed: 7500 min ⁻¹
Maximum engine speed	max 10800 min ⁻¹
Idle speed	1500...1700 min ⁻¹ , Engine at regular operating temperature
Exhaust emissions standard	Euro 4

Clutch

Clutch type	Multiplate clutch running in oil bath
Clutch-lever play	1...2 mm, at the hand lever, handlebars are in straight-ahead position, engine is cold

Transmission

Gearbox type	Claw-shift 6-speed gearbox, integrated into engine block
Gearbox transmission ratios	3.083, Primary transmission ratio 1:3.000, 1st gear 1:2.063, 2nd gear 1:1.588, 3rd gear 1:1.286, 4th gear 1:1.095, 5th gear 1:0.955, 6th gear

Rear-wheel drive

Type of final drive	Continuous Z-ring chain with jerk damping in the rear hub
Chain deflection	40...50 mm, Motorcycle with no weight applied, supported on its side stand
Permissible chain length	max 144.30 mm, measured centre to centre over 10 pins, chain pulled taut
Final drive, number of teeth (Pinion / sprocket)	16/40
Secondary transmission ratio	2.500

Frame

Frame type	Tubular spaceframe
Type plate location	Frame, left
Position of the Vehicle Identification Number	Frame, front right, on steering head

Chassis and suspension

Front wheel

Type of front suspension	Upside-down telescopic fork
Spring travel, front	140 mm, at wheel

Rear wheel

Type of rear suspension	Two-arm aluminium swinging arm
Spring travel, rear	131 mm, at wheel

Brakes

Front wheel

Type of front brake	4-piston fixed caliper
Brake-pad material, front	Sintered metal
Brake disc thickness, front	5.0 mm, when new min 4.5 mm, Wear limit

Rear wheel

Type of rear brake	1-piston floating caliper
Brake-pad material, rear	Organic material
Brake disc thickness, rear	4.5 mm, when new min 4 mm, Wear limit
Blow-by clearance of the footbrake lever	2.0...2.5 mm, between footbrake lever and limit position on footrest plate

Wheels and tyres

Speed category, front/rear tyres	P
----------------------------------	---

Front wheel

Front wheel type	Aluminium cast wheel
Front wheel rim size	3.00 " x 17 "
Tyre designation, front	110/70 R 17
Load index, front tyre	min. 37
Permissible front-wheel imbalance	max 5 g

Rear wheel

Rear-wheel type	Aluminium cast wheel
Rear wheel rim size	4.0 " x 17 "
Tyre designation, rear	150/60 R 17
Load index, rear tyre	min. 56
Permissible rear-wheel imbalance	max 45 g

Tyre pressure

Tyre pressure, front	2.2 bar, with cold tyres; one-up and two-up riding
Tyre pressure, rear	2.3 bar, with cold tyres; one-up and two-up riding

Electrical system

Fuses

Fuse 1	7.5 A, Oxygen sensor, tank vent valve, secondary air system, injection system, electric fuel pump
Fuse 2	7.5 A, Heated grips, engine control unit, ABS pressure modulator, diagnostic connector, extra socket
Fuse 3	30 A, Main fuse
Fuse 4	20 A, ABS pressure modulator
Fuse 5	15 A, Lighting, horn
Fuse 6	10 A, Instrument cluster, engine control unit
Fuse for radiator fan	7.5 A, Radiator fan

Battery

Battery type	AGM (Absorbent Glass Mat) battery
Battery rated voltage	12 V
Battery rated capacity	8 Ah

Spark plugs

Spark plugs, manufacturer and designation	NGK LMAR9D-J
Electrode gap of spark plug	0.8 \pm 0.1 mm

Lighting

Bulb for low-beam and high-beam headlight	H4 / 12 V / 60 W / 55 W
Bulb for parking light	W5W / 12 V / 5 W
Bulb for tail light/brake light	LED
Light source for the number plate light	LED integrated in rear light
Bulbs for flashing turn indicators, front	RY10W / 12 V / 10 W
Bulbs for flashing turn indicators, rear	RY10W / 12 V / 10 W

Dimensions

Length of motorcycle	2005 mm, over number-plate carrier
Height of motorcycle	1080 mm, without mirror, at DIN unladen weight
Width of motorcycle	849 mm, across mirrors 820 mm, without mounted parts
Front-seat height	785 mm, without rider at DIN unladen weight
Rider's inside-leg arc, heel to heel	1760 mm, Without rider, at DIN unladen weight

Weights

Vehicle kerb weight	158.5 kg, DIN unladen weight, ready for road, 90 % load of fuel, without OE
Permissible gross weight	345 kg
Maximum payload	186.5 kg

Riding specifications

Starting capability on uphill gradients (at permissible gross weight)	max 20°
Top speed	143 km/h

Accessories

Maximum permissible speed for riding with topcase fitted to the vehicle	
– with topcase ^{OA} or – with topcase Light ^{OA}	max 130 km/h
Payload of topcase	
– with topcase ^{OA} or – with topcase Light ^{OA}	max 3 kg

Service

BMW Motorrad Service	126
BMW Motorrad Mobility services	126
Maintenance work	126
Maintenance schedule	129
Confirmation of maintenance work	130
Confirmation of service	144

BMW Motorrad Service

BMW Motorrad has an extensive network of dealerships in place to look after you and your motorcycle in more than 100 countries. Authorised BMW Motorrad dealerships have the technical information and the technical know-how to carry out reliably all maintenance and repair work on your BMW.

You can locate your nearest authorised BMW Motorrad dealership by visiting our website:

bmw-motorrad.com



WARNING

Maintenance and repair work not in compliance with correct procedure

Risk of accident due to consequential damage

- BMW Motorrad recommends having work of this nature carried out on the vehicle by a

specialist workshop, preferably an authorised BMW Motorrad dealer. ◀

In order to help ensure that your BMW is always in optimum condition, BMW Motorrad recommends compliance with the maintenance intervals specified for your motorcycle. Have all maintenance and repair work that is carried out confirmed in the "Service" chapter in this manual. For generous treatment of claims submitted after the warranty period has expired, evidence of regular maintenance is essential.

Your authorised BMW Motorrad dealer can provide information on BMW services and the work undertaken as part of each service.

BMW Motorrad Mobility services

As the owner of a new BMW motorcycle, in the event of a breakdown you can benefit from the protection afforded by the various BMW Motorrad mobility services (e.g. BMW Mobile Service, breakdown service, vehicle recovery service). Your authorised BMW Motorrad dealer will be happy provide information about the mobility services available to you.

Maintenance work

BMW pre-delivery check

Your authorised BMW Motorrad dealer conducts the BMW pre-delivery check before handing over the vehicle to you.

BMW Running-in check



Mileage until the running-in check

500...1200 km

BMW Service

The BMW Service is carried out once a year; the extent of servicing can vary, depending on the age of the vehicle and the distance it has covered. Your authorised BMW Motorrad dealer confirms that the service work has been carried out and enters the date when the next service will be due.

Riders who cover long distances in a year might have to bring in their vehicles for service before the next scheduled date. It is to allow for these cases that a maximum odometer reading is entered as well in the confirmation of service. Servicing has to be brought forward if this odo-

meter reading is reached before the next scheduled date for the service.

The service-due indicator in the multifunction display reminds you about one month or 1000 km in advance when the time for a service is approaching, on the basis of the programmed values.

To find out more about service go to:

bmw-motorrad.com/service

The maintenance tasks necessary for your vehicle are set out in the maintenance schedule below:

Maintenance schedule

- 1** BMW Running-in check
 - 2** Standard BMW service
 - 3** Engine-oil change, with filter
 - 4** Replace air filter element
 - 5** Replace chainset
 - 6** Replace spark plug
 - 7** Check valve clearance
 - 8** Oil change in the telescopic forks
 - 9** Replace fuel filters and fuel hoses
 - 10** Replace intake silencer hoses for the cylinder head and tank vent valve
 - 11** Change brake fluid, entire system
- ^a annually or every 10.000 km (whichever comes first)
- ^b for the first time after one year, then every 2 years

^c every 40.000 km or every 4 years (whichever comes first)

Confirmation of maintenance work

BMW Motorrad Service, standard scope

The activities in the BMW Motorrad Service standard scope are listed below. The actual scope of maintenance work for your vehicle may differ.

- Performing vehicle test with BMW Motorrad diagnosis system
- Check coolant level
- Check/adjust the clutch play
- Check the freedom of movement of the throttle cable and check for kinks and chafing
- Checking the front brake pads and brake disc for wear
- Checking the rear brake pads and brake disc for wear
- Visually inspecting the brake lines, brake hoses and connections
- Checking tyre pressures and tread depth
- Checking chain sag
- Checking the brake fluid level of the front wheel brake
- Checking the brake fluid level of the rear wheel brake
- Check the steering-head bearing
- Lubricating the side stand
- Check the lights and signalling equipment
- Function test, engine start suppression
- Final inspection and check for road safety
- Setting the service due date and remaining distance before next service
- Checking battery charge state
- Confirming the BMW service in the on-board literature

BMW Pre-delivery Check

Completed

on _____

Stamp, signature

BMW Running-in Check

Completed

on _____

Odometer reading _____

Next service

at the latest

on _____

or, if reached beforehand

Odometer reading _____

Stamp, signature

BMW Service

Completed

on _____

Odometer reading _____

Next service

at the latest

on _____

or, if reached beforehand

Odometer reading _____

Stamp, signature

Item

BMW Motorrad Service, standard
scope

Yes

No

Oil change, engine, with filter

Checking valve clearance

Renewing air cleaner insert

Replacing chainset

Oil change in telescopic front forks

Renewing all spark plugs

Replacing fuel filters and fuel hoses (at
maintenance)Replace hoses from intake silencer to
cylinder head and tank vent valve (at
maintenance)

Change brake fluid in entire system

Notes

BMW Service

Completed

on _____

Odometer reading _____

Next service

at the latest

on _____

or, if reached beforehand

Odometer reading _____

Stamp, signature

Item

Yes

No

BMW Motorrad Service, standard
scope

Oil change, engine, with filter

Checking valve clearance

Renewing air cleaner insert

Replacing chainset

Oil change in telescopic front forks

Renewing all spark plugs

Replacing fuel filters and fuel hoses (at
maintenance)Replace hoses from intake silencer to
cylinder head and tank vent valve (at
maintenance)

Change brake fluid in entire system

Notes

BMW Service

Completed

on _____

Odometer reading _____

Next service

at the latest

on _____

or, if reached beforehand

Odometer reading _____

Stamp, signature

Item

BMW Motorrad Service, standard
scope

Yes

No

Oil change, engine, with filter

Checking valve clearance

Renewing air cleaner insert

Replacing chainset

Oil change in telescopic front forks

Renewing all spark plugs

Replacing fuel filters and fuel hoses (at
maintenance)Replace hoses from intake silencer to
cylinder head and tank vent valve (at
maintenance)

Change brake fluid in entire system

Notes

BMW Service

Completed

on _____

Odometer reading _____

Next service

at the latest

on _____

or, if reached beforehand

Odometer reading _____

Stamp, signature

Item

Yes No

BMW Motorrad Service, standard scope

Oil change, engine, with filter

Checking valve clearance

Renewing air cleaner insert

Replacing chainset

Oil change in telescopic front forks

Renewing all spark plugs

Replacing fuel filters and fuel hoses (at maintenance)

Replace hoses from intake silencer to cylinder head and tank vent valve (at maintenance)

Change brake fluid in entire system

Notes

BMW Service

Completed

on _____

Odometer reading _____

Next service

at the latest

on _____

or, if reached beforehand

Odometer reading _____

Stamp, signature

Item

BMW Motorrad Service, standard
scope

Yes

No

Oil change, engine, with filter

Checking valve clearance

Renewing air cleaner insert

Replacing chainset

Oil change in telescopic front forks

Renewing all spark plugs

Replacing fuel filters and fuel hoses (at
maintenance)Replace hoses from intake silencer to
cylinder head and tank vent valve (at
maintenance)

Change brake fluid in entire system

Notes

BMW Service

Completed

on _____

Odometer reading _____

Next service

at the latest

on _____

or, if reached beforehand

Odometer reading _____

Stamp, signature

Item

Yes

No

BMW Motorrad Service, standard
scope

Oil change, engine, with filter

Checking valve clearance

Renewing air cleaner insert

Replacing chainset

Oil change in telescopic front forks

Renewing all spark plugs

Replacing fuel filters and fuel hoses (at
maintenance)Replace hoses from intake silencer to
cylinder head and tank vent valve (at
maintenance)

Change brake fluid in entire system

Notes

BMW Service

Completed

on _____

Odometer reading _____

Next service

at the latest

on _____

or, if reached beforehand

Odometer reading _____

Stamp, signature

Item

BMW Motorrad Service, standard
scope

Yes

No

Oil change, engine, with filter

Checking valve clearance

Renewing air cleaner insert

Replacing chainset

Oil change in telescopic front forks

Renewing all spark plugs

Replacing fuel filters and fuel hoses (at
maintenance)Replace hoses from intake silencer to
cylinder head and tank vent valve (at
maintenance)

Change brake fluid in entire system

Notes

BMW Service

Completed

on _____

Odometer reading _____

Next service

at the latest

on _____

or, if reached beforehand

Odometer reading _____

Stamp, signature

Item

Yes

No

BMW Motorrad Service, standard
scope

Oil change, engine, with filter

Checking valve clearance

Renewing air cleaner insert

Replacing chainset

Oil change in telescopic front forks

Renewing all spark plugs

Replacing fuel filters and fuel hoses (at
maintenance)Replace hoses from intake silencer to
cylinder head and tank vent valve (at
maintenance)

Change brake fluid in entire system

Notes

BMW Service

Completed

on _____

Odometer reading _____

Next service

at the latest

on _____

or, if reached beforehand

Odometer reading _____

Stamp, signature

Item

BMW Motorrad Service, standard
scope

Yes

No

Oil change, engine, with filter

Checking valve clearance

Renewing air cleaner insert

Replacing chainset

Oil change in telescopic front forks

Renewing all spark plugs

Replacing fuel filters and fuel hoses (at
maintenance)Replace hoses from intake silencer to
cylinder head and tank vent valve (at
maintenance)

Change brake fluid in entire system

Notes

BMW Service

Completed

on _____

Odometer reading _____

Next service

at the latest

on _____

or, if reached beforehand

Odometer reading _____

Stamp, signature

Item

Yes

No

BMW Motorrad Service, standard
scope

Oil change, engine, with filter

Checking valve clearance

Renewing air cleaner insert

Replacing chainset

Oil change in telescopic front forks

Renewing all spark plugs

Replacing fuel filters and fuel hoses (at
maintenance)Replace hoses from intake silencer to
cylinder head and tank vent valve (at
maintenance)

Change brake fluid in entire system

Notes

BMW Service

Completed

on _____

Odometer reading _____

Next service

at the latest

on _____

or, if reached beforehand

Odometer reading _____

Stamp, signature

Item

BMW Motorrad Service, standard
scope

Yes

No

Oil change, engine, with filter

Checking valve clearance

Renewing air cleaner insert

Replacing chainset

Oil change in telescopic front forks

Renewing all spark plugs

Replacing fuel filters and fuel hoses (at
maintenance)Replace hoses from intake silencer to
cylinder head and tank vent valve (at
maintenance)

Change brake fluid in entire system

Notes

BMW Service

Completed

on _____

Odometer reading _____

Next service

at the latest

on _____

or, if reached beforehand

Odometer reading _____

Stamp, signature

Item

Yes

No

BMW Motorrad Service, standard
scope

Oil change, engine, with filter

Checking valve clearance

Renewing air cleaner insert

Replacing chainset

Oil change in telescopic front forks

Renewing all spark plugs

Replacing fuel filters and fuel hoses (at
maintenance)Replace hoses from intake silencer to
cylinder head and tank vent valve (at
maintenance)

Change brake fluid in entire system

Notes

Confirmation of service

The table is intended as a record of maintenance and repair work, the installation of optional accessories and, if appropriate, special campaign (recall) work.

Item	Odometer reading	Date

Item	Odometer reading	Date

A

Abbreviations and symbols, 6

ABS

- Engineering details, 60
- Self-diagnosis, 50
- Warning light, 27

Accessories

- General instructions, 100
- Power socket, 101
- Topcase, 101, 104

Actuality, 7

Anti-lock brake system ABS, 52

Average values

- Displaying average consumption (CONS1), 36
- Displaying average speed (SPEED), 36
- reset, 38

B**Battery**

- connecting to motorcycle, 93
- disconnecting from motorcycle, 92
- install, 94
- Maintenance instructions, 91

Position on the vehicle, 14

recharging connected

battery, 92

recharging disconnected

battery, 92

remove, 93

Technical data, 122

Vehicle voltage is too low, 25

Beam throw

Adjusting, 43

Brake fluid

Checking fluid level, front, 71

Checking fluid level, rear, 72

Reservoir, front, 13

Reservoir, rear, 13

Brake pads

Checking front, 69

checking rear, 70

Running in, 51

Brakes

Checking function, 68

Safety instructions, 52

Technical data, 119

C**Care**

Body panels, 109

Care products, 108

Chrome, 109

Paint, 110

Plastics, 109

Preserving paintwork, 110

Radiator, 109

Rubber, 109

Washing the vehicle, 108

Chain

Adjusting tension, 84

Adjustment values, 11

Checking tension, 84

Checking wear, 85

Lubricating, 85

Checklist, 48**Clock**

Adjusting, 37

Clutch
Adjusting play, 74
Checking function, 73
Checking play, 73
Technical data, 117

Confirmation of maintenance work, 130

Coolant
Checking fill level, 74
Fill-level indicator, 13
topping up, 75
Warning light for overheating, 25

Coolant temperature
Displaying (ENGIN), 36
too high, 25

D

Date
Adjusting, 37
Displaying (DATE), 36
Service due date, 28

Diagnostic connector
Loosen, 96
secure, 97

Dimensions
Technical data, 123

E

Electrics
Technical data, 122

Emergency off switch (kill switch)
Emergency-off, 33
operate, 33
Operation mode, 33
Position on the vehicle, 16

Emissions warning light, 26

Engine
In emergency operation, 25
Malfunction indicator lamp, 26
parking, 33
Severe fault, 26
starting, 48
Technical data, 116

Engine oil
Checking fill level, 67
Oil filler neck, 11
Technical data, 115
topping up, 67, 68

Equipment, 7

F

Frame
Technical data, 118

Front-wheel stand
Installing, 65

Fuel
Displaying current consumption (CONSA), 36
Filler neck, 13, 55
Fuel grade, 54
refuelling, 55
Technical data, 115

Fuel reserve
Range, 29
Telltale light, 27

Fuel reserve indicator light, 27

Fuses
Position on the vehicle, 14
replacing, 94
Technical data, 122

G

General views
Instrument panel, 17
Left multifunction switch, 15
Left side of the vehicle, 11

Multifunction display, 21
Right multifunction switch, 16
Right side of the vehicle, 13
Underneath the seat, 14
Warning and telltale lights, 20

H

Headlight
Adjusting, 42
Adjusting headlight beam throw, 43
Adjustment for driving on left/driving on right, 42
Headlight beam throw and spring preload, 43
Headlight flasher
operate, 34
Heated handlebar grips
operate, 100
High-beam headlight
switching on, 34
Horn, 15

I

Ignition
switching off, 33
switching on, 32
Instrument panel
Overview, 17
Photosensor, 17
Redline warning, 17
Warning and telltale lights, 17

J

Jump-start, 90

K

Keys, 32

L

Laying up, 110
Lighting
Replacing bulb for parking light, 87
Replacing bulbs for front and rear turn indicators, 89
Replacing bulbs for low-beam headlight and high-beam headlight, 86

Replacing LED rear light, 90
Replacing LED turn indicators, 90
Replacing number-plate light, 90
Technical data, 123

Lights

Adjusting headlight, 42
Control, 15
Headlight flasher, operating, 34
High-beam headlight, operating, 34
Low-beam headlight, operating, 34
Parking lights, operating, 34

Luggage

Grab handle, 13
Instructions for loading, 46

M

Maintenance
General instructions, 64
Maintenance intervals, 126
Maintenance schedule, 129

Mirrors
 Adjusting, 42

Mobility services, 126

Motorcycle
 care, 107
 cleaning, 107
 Lashing, 56
 laying up, 110
 parking, 53
 restoring to use, 110

Multifunction display, 17
 Overview, 21
 Select display, 36

Multifunction switch
 General view, left side, 15
 General view, right side, 16

O

Odometer
 Displaying (ODO), 36

Odometer and tripmeters
 reset, 37

P

Paint care, 110

Parking, 53

Photosensor, 17

Power socket
 Notes on use, 101
 Position on the vehicle, 11

Pre-Ride-Check, 49

R

Range
 Displaying (RANGE), 36

Rear-wheel drive
 Technical data, 118

Rear-wheel stand
 Installing, 66

Redline warning, 52

Refuelling, 55
 Fuel grade, 54

Rev. counter
 Engine speed display, 30

Rider's Manual
 Position on the vehicle, 14

Riding specifications
 Technical data, 124

Running gear
 Technical data, 119

Running in, 51

S

Safety instructions
 for brakes, 52
 for riding, 46

Seat
 install, 39
 Lock, 11
 remove, 38

Service, 126
 Reading, 28

Service-due indicator, 28

Settings
 Displaying (SETUP), 36
 Headlight, 42
 Mirrors, 42
 Spring preload, 44

Spark plugs
 Technical data, 122

Speedometer, 21

Spring preload
Adjuster, rear, 11

Adjusting, 44

Starting, 48

Control, 16

Steering lock

Locking, 32

T

Technical data

Battery, 122

Brakes, 119

Chassis and suspension, 119

Clutch, 117

Dimensions, 123

Electrical system, 122

Engine, 116

Engine oil, 115

Frame, 118

Fuel, 115

Fuses, 122

Lighting, 123

Rear-wheel drive, 118

Riding specifications, 124

Spark plugs, 122

Standards, 7

Transmission, 117

Weights, 124

Wheels and tyres, 120

Telltale lights, 17

Fuel reserve, 27

Overview, 20

Threaded fasteners, 113

Toolkit

Contents, 64

Position on the vehicle, 14

Topcase

operate, 101, 104

Torques, 113

Transmission

Technical data, 117

Trim panels

Closing the front mask, 88

Opening the front mask, 86

Removing and installing front
trim panel, 43

Trip meter

Displaying (TRIP1, TRIP2), 36

Troubleshooting chart, 112

Turn indicators

Control, 15

operate, 34

Type plate

Position on the vehicle, 11

Tyres

Checking tread depth, 75

Checking tyre pressure, 76

Pressures, 121

Running in, 51

Table of tyre pressures, 11

Technical data, 120

Top speed, 47

V

Vehicle Identification Number

Position on the vehicle, 13

VIN

Vehicle Identification
Number, 13

W

Warning lights, 17

On-board voltage, 25

Overview, 20

Warnings

ABS, 27

Coolant temperature, 25

Engine warning, 26

Malfunction indicator lamp, 26

Mode of presentation, 22

Overtemperature, 25

Symbol for engine
electronics, 25

Warnings, overview, 23

Weights

Payload table, 11

Technical data, 124

Wheels

Change of size, 76

Checking rims, 75

Installing front wheel, 78

Installing the rear wheel, 82

Removing front wheel, 76

Removing rear wheel, 80

Technical data, 120

Details described or illustrated in this booklet may differ from the vehicle's actual specification as purchased, the accessories fitted or the national-market specification. No claims will be entertained as a result of such discrepancies.

Dimensions, weights, fuel consumption and performance data are quoted to the customary tolerances.

The right to modify designs, equipment and accessories is reserved.

Errors and omissions excepted.

© 2016 Bayerische Motoren Werke Aktiengesellschaft
80788 Munich, Germany
Not to be reproduced by any means whatsoever, wholly or in part, without the written permission of BMW Motorrad, After Sales.

Original rider's manual, printed in Germany.

Important data for refuelling:

Fuel	
Recommended fuel grade	Regular, unleaded (max. 10 % ethanol, E10) 91 ROZ/RON 87 AKI
Usable fuel capacity	approx. 11 l
Fuel reserve	approx. 1 l
Tyre pressure	
Tyre pressure, front	2.2 bar, with cold tyres; one-up and two-up riding
Tyre pressure, rear	2.3 bar, with cold tyres; one-up and two-up riding

You can find further information on all aspects of your vehicle at:
bmw-motorrad.com

BMW recommends **ADVANTEC**
ORIGINAL BMW ENGINE OIL

Order No.: 01 40 8 392 971
04.2016, 3rd edition, 01

