



We are bridging the gap.

ABB Digital Substation

ABB's Digital Substation is a core enabler to increase safety, productivity and reliability for grid operators and to reduce the overall substation cost.



- Key ABB Digital Substation technologies explained
- Mastering the control room of the future
- Extending the digital grid

—

“ABB’s Digital Substation provides customers in the utility sector with unmatched control and efficiency. The digital substation reduces maintenance requirements and the need for miles of conventional cabling. ABB takes these advances several steps further by combining the latest electrical gear with digital sensors and cloud computing. The result is that grid operators can make decisions based on comprehensive, up-to-the-moment information, while predictive algorithms can improve maintenance practices and asset management.”

Claudio Facchin
President, Power Grids division

— Table of contents

008–009	Leading substation development
010–011	ABB’s Digital Substation is a significant breakthrough
012–013	ABB Digital Substation benefits
014	Key ABB Digital Substation technologies
015	The substation evolution
016–017	Helping to defend the digital grid
018–019	Six layers of protection
020–021	Mastering the control room of the future takes ability
022–023	ABB Ability™ Ellipse® connected asset lifecycle management (CALM)
024–025	ABB Ability™ Ellipse® APM
026–027	ABB Ability™ Network Manager™
028	MicroSCADA Pro Historian

Table of contents

029	SDM600	046	Relion® 670 series
030	Monitoring & diagnostics	047	Relion® 650 and REB500 series
031	Modular Switchgear Monitoring (MSM), generator circuit-breaker monitoring system GMS600	048	IET600
032–033	Transformers	049	ITT600, PCM600
034–035	FOX615	050–051	SAM600 process bus I/O system
036	MicroSCADA Pro Local and remote control of the substation	052	Innovative high-voltage gas-insulated switchgear
037	RTU500 series Intelligence distributed across your power grid	053	Non-conventional instrument transformers (NCITs)
038–039	Medium voltage switchgear	054	Innovative high-voltage hybrid switchgear
040	Voltage sensors for digital switchgear	055	Innovative high-voltage switchgear
041	Arc fault protection	056	Innovative high-voltage air-insulated switchgear (AIS)
042	Relion® 615/620 series	057	Free-standing fiber optic current sensor (FOCS-FS)
043	Relion® 620 series Remote I/O unit	058–059	ABB Power Grids service

ABB's Digital Substation is a core enabler to increase safety, productivity and reliability for grid operators and to reduce the overall substation cost.

Digital substations remove the last electrical connection between the high voltage equipment and the protection and control panels, creating a safer work environment, while reducing the costs for building, land, engineering, commissioning, operation and maintenance of the system. As a key component towards smarter grids, where utilities continue to integrate increasing amounts of intermittent renewable energy sources, digital substations offer improved data quality and a shorter decision time in the event of an emergency.



Leading substation development for over 100 years.

Dependable substation performance is a key factor for grid reliability. ABB has been designing and building substations since the 1900s.

Since then, we have supplied tens of thousands of air-insulated, gas-insulated and hybrid substations with voltage levels up to 1,200kV to a range of very different sites, from the most densely-populated locations to the harshest environments on earth.

Our first major technological step was in 1965, with the introduction of gas-insulated switchgear (GIS) that reduced substation footprints. Alongside the development of GIS technologies, ABB has significantly improved the performance of conventional air-insulated switchgear (AIS) substations.

The latest innovation, the “combined” disconnecter circuit breaker (DCB), integrates the disconnecting function into the circuit breaker. This eliminates the need for two separate, free-standing disconnectors and reduces the substation footprint by more than 50 percent. ABB is the first company to develop this technology for voltage levels up to 500kV.

In the late 1980s, our innovations in substation automation replaced conventional protection and control systems with numerical ones. ABB is also dedicated to the development of industry standards, including those used in substation automation. We have been a driving force in the development and verification of the IEC 61850 substation communications standard since 1995.

Since implementing the world’s very first IEC 61850 multi-vendor substation automation system in 2004, ABB has supplied thousands of products and systems for new and retrofit projects. ABB is the world’s leading supplier of air-insulated, gas-insulated and hybrid switchgear and substations, utility communication networks, as well as IEC 61850 substation automation, protection and control solutions and systems.



ABB Ability™

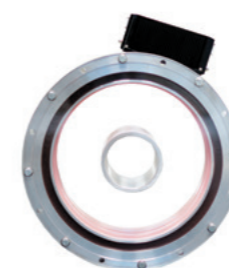
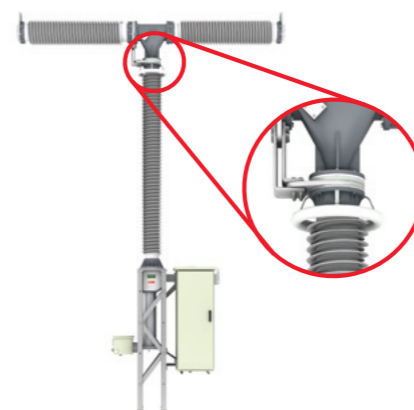

2017

ABB Ability™ launched

Enabling end to end digitalization from the process level to the control room and beyond.

2011

New applications

First installation of FOCS optical CT integrated in 400kV disconnecting circuit breaker.

1998

Sensors

Commissioning of the first digital substation with sensors for current and voltage.

1900s

Conventional

Instrument transformers.

ABB Digital Substation

A significant breakthrough in substation technology.

Based on the seamless integration of state-of-the-art IEC 61850-based control and protection IEDs, with all relevant primary components and sensors of a modern substation, the primary components include high and medium-voltage switchgear, as well as substation transformers.

— 01 Protection and control building including automation, protection and control, and IEC 61850 station bus.

— 02 MPLS-TP network remote connectivity via ABB FOX615 utility hardened multiplexer.

— 03 Transformer with electronic control monitoring and diagnostics.

— 04 Integrated non-conventional instrument transformers.

— 05 Merging units & process I/O bridging the gap between analogue and digital world. Compliant to IEC 61850.

— 06 IEC 61850 process bus connecting the switchyard to the protection and control system.

— 07 ABB Ability Network Manager™ control center solutions to ensure secure and efficient energy system operation.

The defining feature of a digital substation is the implementation of a process bus. The IEC 61850 process bus enables the substitution of point-to-point copper connections between IEDs, other devices (e.g., instruments transformers, gas monitoring, MotorDrive™, etc.) and switchgear by means of a safe, standardized optical communication bus. Thanks to the process bus, real-time measurement signals and status information can be broadcast throughout a substation without complex wiring schemes.

In the late 1990s, ABB commissioned the world's first digital substation in Australia for Powerlink, a transmission service provider in Queensland. Even though the concept has evolved since then, the basic principles remain the same: substituting heavy, bulky current and voltage sensors with small, integrated sensors and substitute signaling copper wires with fiber optic communication buses.

From 2008 onwards, ABB introduced the IEC61850-9-2 process bus between non-conventional instrument transformers and protection and control equipment. Digital substations enable electric power utilities to increase productivity, reduce footprint, increase functionality, improve the reliability of assets and, crucially, improve safety for service personnel. Digital substations exploit the benefits of digital protection, control and communication technologies, mirroring the trend towards digitalization seen in many other industries.

This trend towards digitalization also applies to other areas of the substation. Within medium-voltage switchgear panels, the horizontal exchange of IEC 61850-8-1 GOOSE and sampled analog values reduces wiring and accelerates the testing and commissioning. Digitalized technology can now continuously monitor mission-critical functions of high and medium voltage switchgear as well as substation transformers, while performing real-time simulation and diagnostics, ensuring that the pro-active management of the assets lifecycle is now possible.

The availability of increasing amounts of data in the substation calls for better solutions to turn this data into actionable information, and to ensure that data is properly and securely managed. The latest substation data management and asset health management solutions offer means for a power utility to exploit the latest advances in this area.

The ABB Digital Substation has also paved the way for well-known innovative switchgear solutions such as PASS (plug and switch system) and most recently the disconnecting circuit breakers with integrated fiber optic current sensors (DCB with FOCS).



ABB Digital Substation benefits.

Bridging the gap between analogue and digital. Enabling a safer work environment, reduced maintenance costs and end-to-end digitalization from the process level to the control room and beyond.

Thousands of engineering-intensive and costly point-to-point copper signaling wires can be replaced by few fiber optic communication buses. The IEC 61850 standard safeguards the investment of the substation owners and enables interoperability between vendors of substation equipment.

Safety is improved because less signal connections or inadvertently-opened CT circuits can harm personnel during commissioning and service activities. Ultra-fast earthing switches installed in medium-voltage cubicles prevent disruptive and catastrophic damages caused by arcing faults. Digital substations enable the reduction of the footprint of a substation because less space is required for protection and control panels and functions previously executed by physically separate equipment can now be integrated in one device.

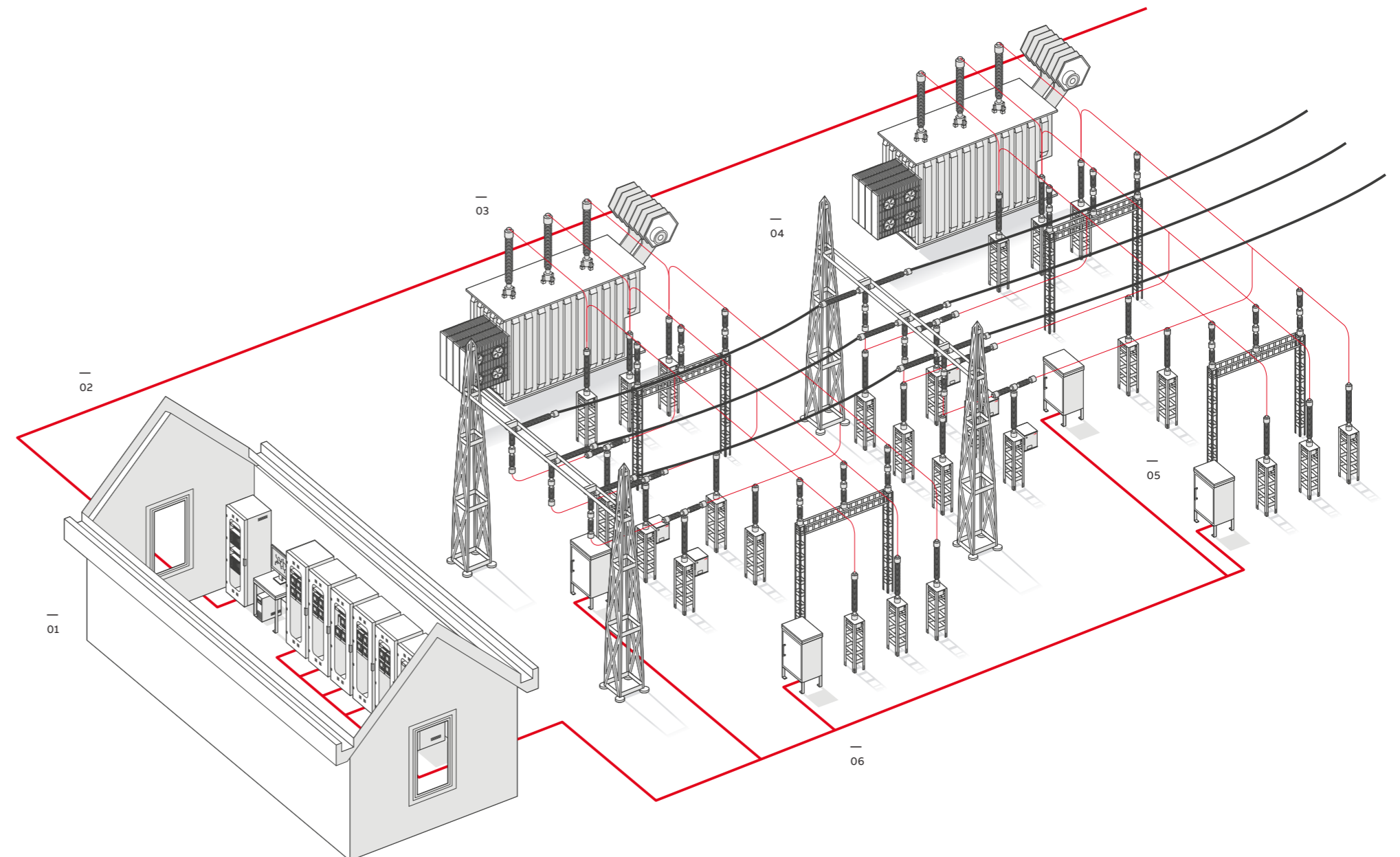
For example, in air-insulated switchgear (AIS) substations, a current measurement transformer can be replaced by an optical sensor (fiber optic current sensor) and fully integrated inside a live tank breaker together with disconnecting and earthing functions. In the case of an AIS substation, the footprint can be reduced by 50% compared to a conventional solution*.

Higher productivity can be achieved by means of new asset management systems with monitoring and diagnostics data from substation equipment. This feature substantially improves the efficiency of service activities. Monitoring and diagnostics is a strategic feature for utilities, further reducing outage time and increasing reliability.

Transient stresses can be mitigated by means of point-on-wave switching, which needs data from various sensors, meaning in many cases expensive closing resistors become obsolete. To meet the increased need for the flexibility of the transmission and distribution grids, digital substations provide data and information that is required for the control of grid stability and for a quick response to changing grid conditions due to the integration of intermittent resources.

Digital substations bring unseen opportunities for modern utilities.



Cyber Security
Protecting systems from cyber abuse or vandalism from the outside world.



Increased safety
Digital substations reduce the risk of electrical shock by substituting copper wires with fiber optic cables.



Improved asset management
Gain control of substation hardware with second-by-second analysis and control.



Backwards compatibility
Deep integration with legacy products, supporting utility communication from the past and into the future.

Up to 80% copper cable reduction*

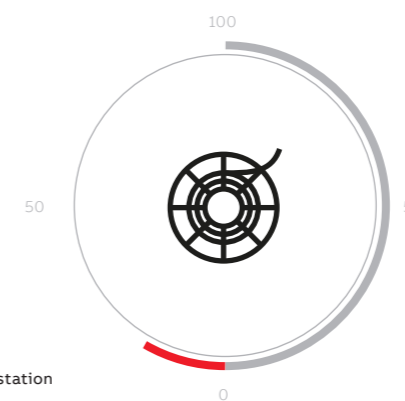

40% shorter installation phase**

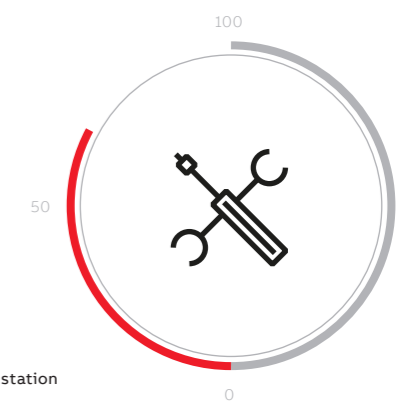

Up to 60% less space in the relay house*

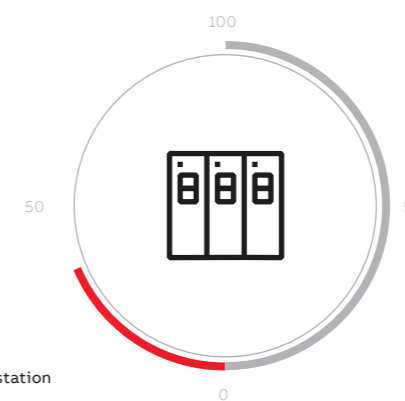

Operational cost reduction***

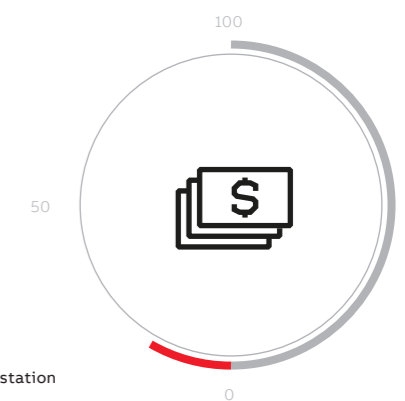

* Based on a typical conventional 400kV double busbar AIS substation compared to a modern variant using SAM600 process bus I/O system and FOCS integrated in disconnecting circuit breakers.
 ** Of new secondary systems.
 *** During secondary system retrofits.



Future-proof
Digital substations enable faster implementation of future technologies.



Lower CT requirements
Digitizing data right in the field, reduces burden and lowers CT requirements.



Software-based testing
Safe testing with software based simulation and verification.

Key ABB Digital Substation technologies.

Digitalization affects all components and aspects of a substation.

To deploy their full benefits for the owner and operator, digital substation features have to be planned and designed during the specification phase. This ensures that in the medium term, substantial productivity gains are achievable in operation thanks to better asset utilization and to synergies between various departments such as station control, automation and protection.

1. High-voltage primary equipment

Primary high-voltage switchgear in air-insulated technology (AIS), gas-insulated technology or hybrid technology (PASS) non-conventional instrument transformers enable a smaller substation footprint and easier engineering. Alternatively, existing CTs and VTs can be connected to stand-alone merging units, which connect the analog measurement signals to the process bus.

2. Protection, supervision and control

The substation automation, protection and control system solutions ensure reliable power transmission and distribution. To ensure inter-operable and future-proof solutions, the substation automation, protection and control system has to be designed to implement the core values of the IEC 61850 standard.

3. Medium-voltage switchgear

Air- and gas-insulated switchgear solutions for primary and secondary distribution that suits various applications like railway power supply and wind farm integration.

4. Communication networks

The communication network inside the substation and from the substation to remote network control centers. These solutions fulfill the highest demands with respect to safety, reliability and real-time response.

Extending the digital grid.

Monitoring & diagnostics

Through remote access, the asset owner can evaluate the status of the equipment without dispatching an engineer to the site, saving both valuable time and resources. Since monitoring detects condition changes in real-time – versus periodically with traditional diagnostic methods – the asset owner has time to plan and act before faults occur.

Historian and system data management

A historian effortlessly collects, archives, and enables you to visualize and analyze the primary process data. System data management software provides for the automatic management of service and cyber security-relevant data across your substations.

Digital operations

An unparalleled range of solutions for asset performance management, operations and workforce management, and network control to help customers reach new levels of efficiency, reliability, safety and sustainability. With the capabilities to integrate information technologies (IT) and operational technologies (OT) to provide complete solutions to our customers' business challenges.

The substation evolution.

Transition from conventional schemes to the ABB Digital Substation.

Traditional substations have always relied on copper cables connecting together primary equipment like circuit breakers, conventional current and voltage transformers

and protection relays. But digital technologies, communications and standards are driving the evolution of something new – ABB Digital Substations.

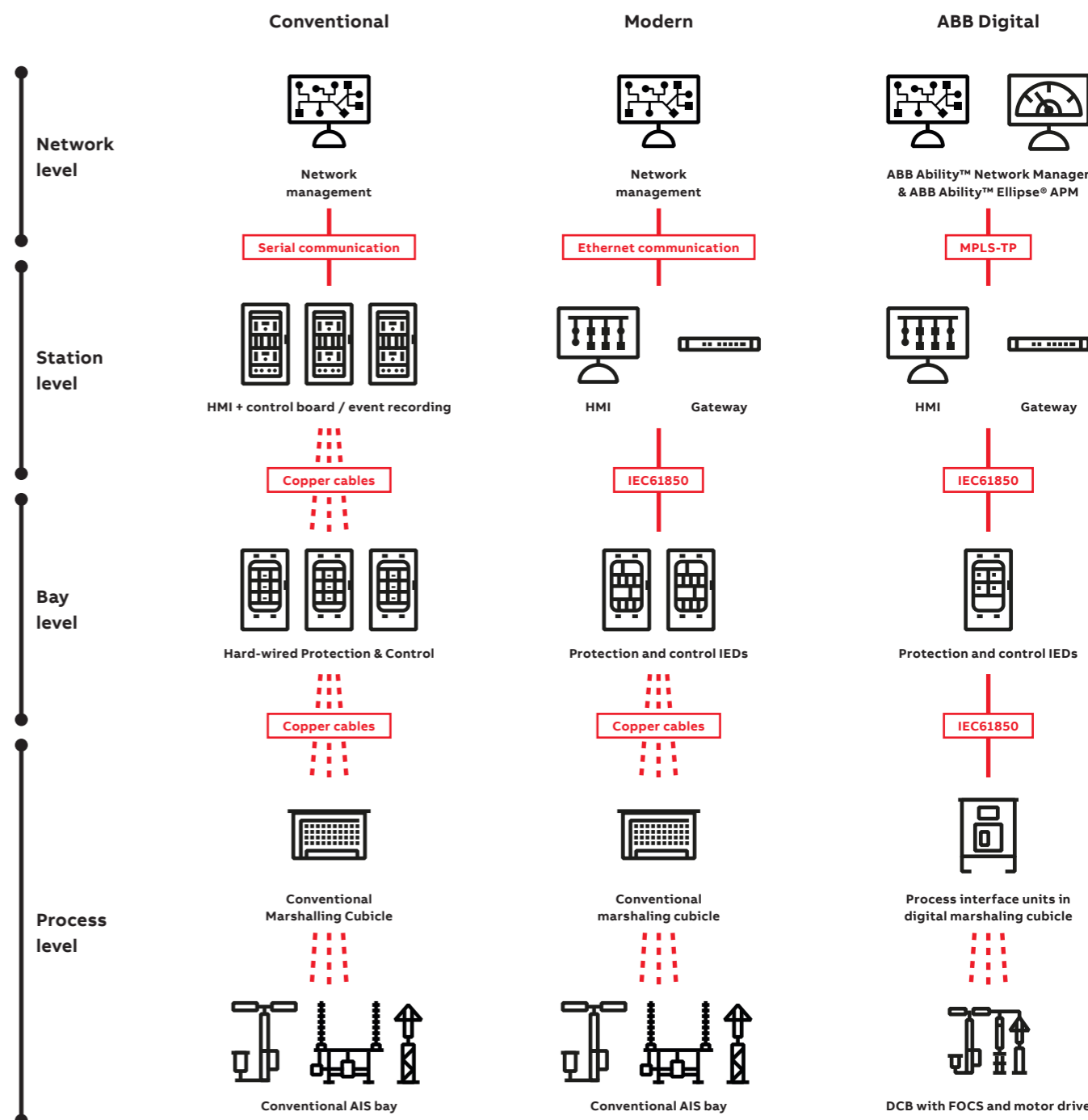

Helping to defend the digital grid.

Three steps to cyber security vigilance.

Grid automation systems require regular maintenance and updates. Out-of-date systems leave you exposed to attack, and the threat increases exponentially the longer you wait. ABB Power Grids service offers a three-step approach to cyber security to help defend your systems:



1 – Assess

To begin the process, ABB carries out a cyber security assessment to help you understand how to improve security throughout your system. A detailed cyber security assessment report is then produced and provided to you, along with a set of recommended actions for improved cyber security.



2 – Implement

ABB provides recommended actions for you to implement based on the cyber security assessment and our experts' domain expertise. Upon agreement, ABB implements the recommendations to your system, ensuring your system is more secure.

3 – Sustain

When you appoint ABB as your cyber security partner, you enter a care agreement that ensures you benefit from ABB's huge domain expertise across the globe. Your system will be regularly assessed by the cyber security care team for any potential cyber security infringements to ensure sustained cyber security vigilance.



Six layers of protection.

Delivering better cyber security via defense in depth.



Security assessment & monitoring – unique security assessment solutions

Assessment and monitoring services for system software, system hardware and communication networks are fundamental in order to keep a system constantly secure. Overseeing the cyber security status of your system, ABB collects system data for comparison against industry best practices and standards to detect weaknesses within your system's defense. This pinpoints areas that require action to help protect your system by ensuring it has multiple layers of security.



Malware protection – evolving protection against sophisticated threats

Our substation automation systems can be equipped with industry-standard malware and intrusion protection solutions, like anti-virus protection and application white-listing.



Procedures & policies – educating and supporting system users

Cyber security will always be a challenge on a global scale. No single solution can keep increasingly-interconnected systems secure, so ABB works with customers to understand your processes and procedures, group security policies and computer settings to create a defense-in-depth approach where multiple security layers detect and deter threats – if, where and when they may arise.



Backup & recovery – preserving the past for a rapid response to tomorrow's challenges

If the worst does happen, and cyber-attack or natural disaster strikes, then the security of an off-site backup will make recovery that much easier. ABB's backup solutions can ensure the integrity and availability of critical data, no matter what happens to the original.



Security updates & hardening – effortlessly updating and improving your system

Modern operating systems and embedded software often need to be patched to defend against emerging threats. Efficient patch management is an essential part of any security policy, but one that is often neglected. Products can be made significantly more robust by closing ports and services that are not in use. Our products have been systematically hardened to ensure that the products are robust against attacks and perform their main function.



Perimeter protection – constantly vigilant for attacks and breaches

Firewalls can protect the perimeter of a network and a well-designed security policy will separate the network into distinct, controlled zones, protected by internal firewalls, to ensure that a compromised server doesn't mean compromising the entire network.

Mastering the control room of the future takes ability.

ABB Ability™

Aging infrastructure, new regulations, distributed energy resources and the convergence of information technology and operations technology (IT/OT) are just a few of the issues that are dramatically changing the utility landscape today.

ABB Ability provides tailored digital solutions and products for the differing needs of utility providers, giving you the operational confidence to know more, do more, do better, together.

Our industry-leading digital capabilities are combined with decades of experience with utilities. This includes over 120 years of experience across the electricity value chain, more than 50,000 experts currently on our team, 7,000 distributed control systems and 5,000 power installations worldwide.



ABB Ability™ Ellipse® connected asset lifecycle management (CALM)

The performance orchestration of priority, process and people.

The most basic mission of any organization is to keep operations efficient, work optimized and assets performing at their peak. This mission is an endless challenge as assets age, the workforce transitions and demand for additional asset output increases.

ABB Ability Ellipse is ABB's connected asset lifecycle management solution that unifies world-class functionality for enterprise asset management (EAM), workforce management (WFM) and asset performance management (APM). Communication and connection between the three cornerstone functions of Ellipse drive continuous, successful operations. From strategy through execution, Ellipse is a robust and comprehensive business and technology solution.

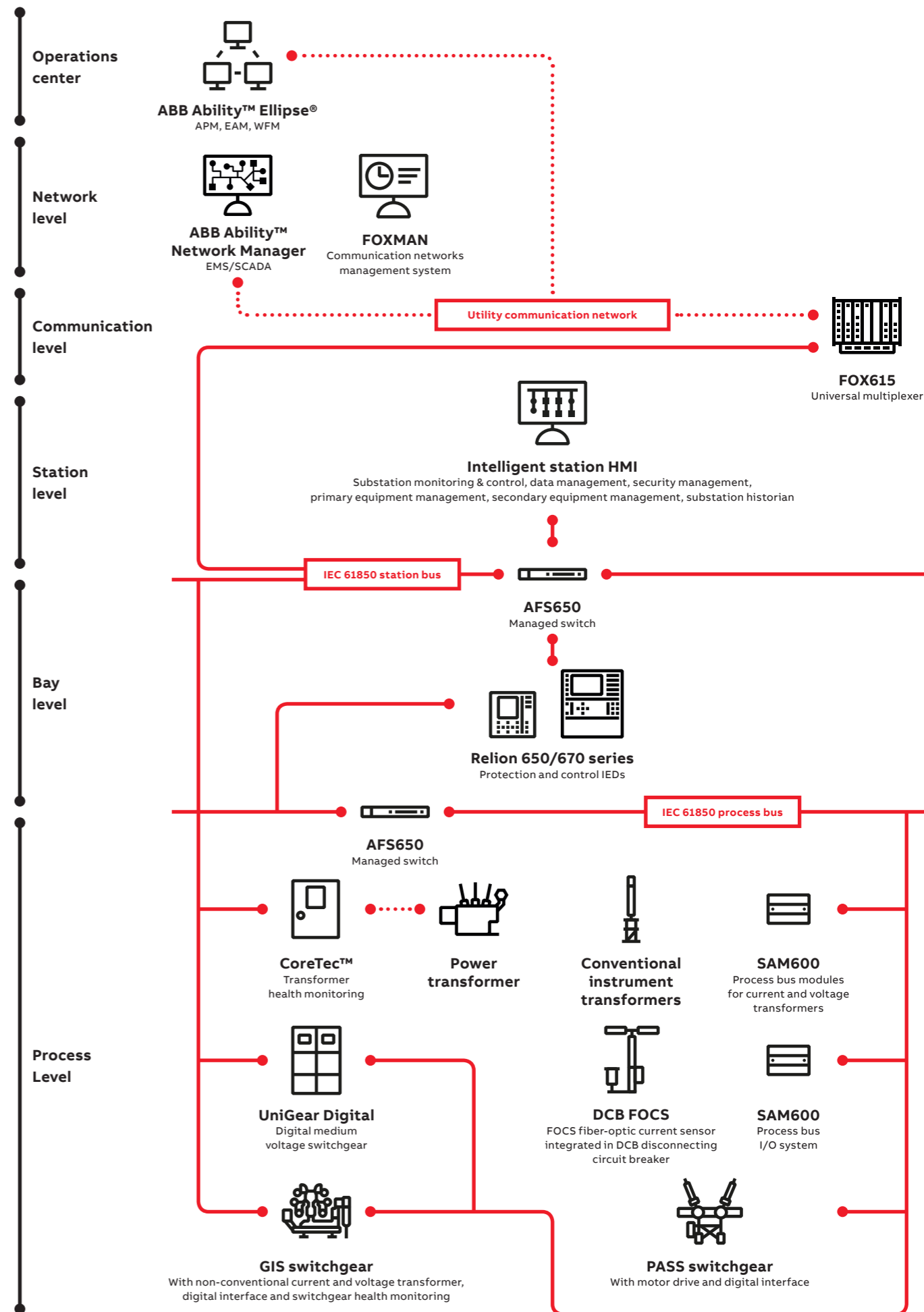
With ABB Ability Ellipse, you can reap the rewards of digitalization sooner than you ever thought possible.

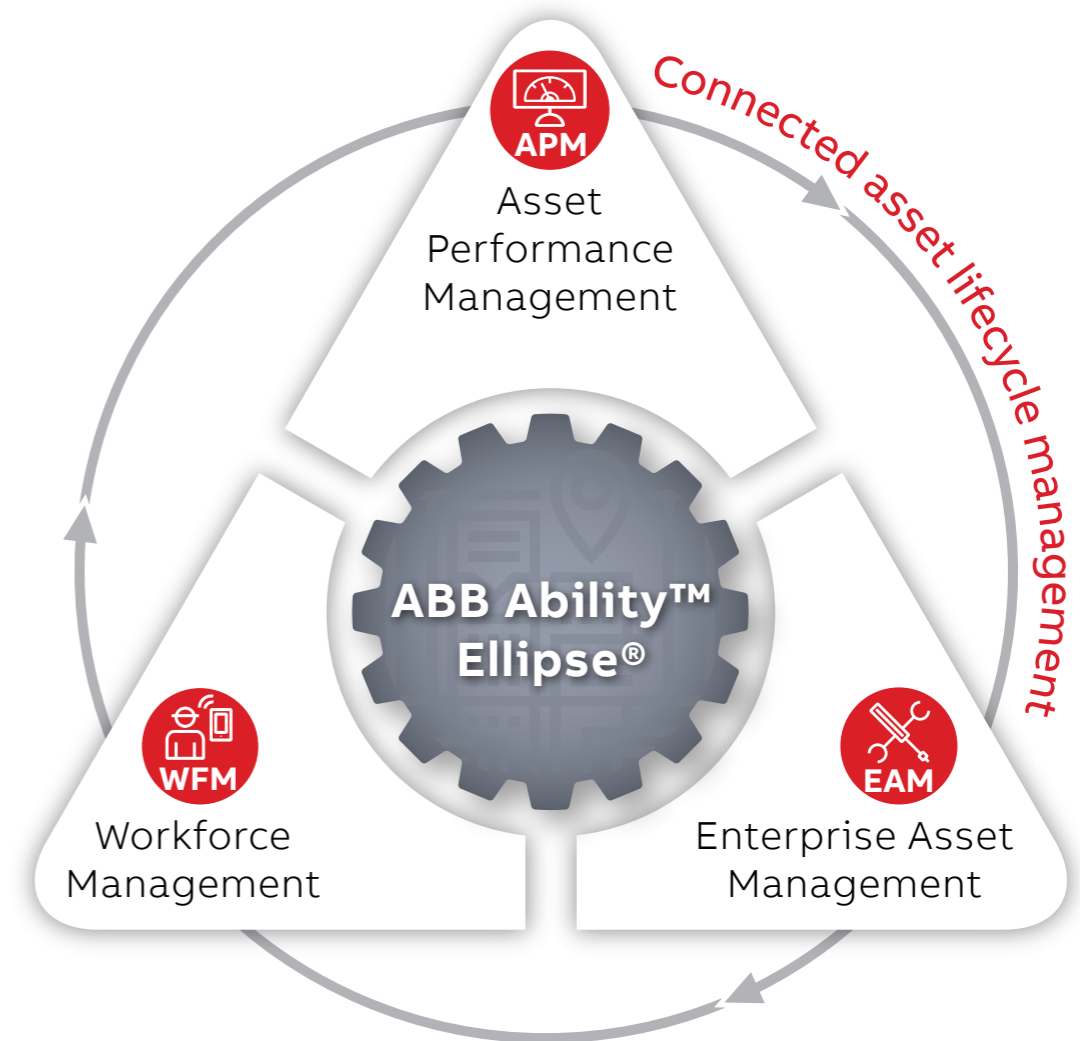

Ellipse APM

- Combines the strengths of monitoring data, industry expertise and machine learning technology for continual operations improvement
- Proactively predicts, prescribes and prioritizes maintenance activity based on potential risk of asset failure and operational criticality



Ellipse EAM

- End-to-end best practices for the day-to-day and lifecycle management of assets and work, as well as supply chain management, human resources management and financial management



Ellipse WFM

- Improves responsiveness by delivering critical maintenance information to field technicians such as reports, images, instructions and video
- Easily relays input of field activity and asset information from the job site to the EAM system



ABB Ability™ Ellipse® APM

Asset performance management, from field data to fleet optimization.

Ellipse APM is one of three cornerstone components of ABB Ability Ellipse.

In today's environment, utilities face many challenges, including aging assets, stagnant budgets, new operating risks resulting from distributed energy resources and a workforce in transition. Utilities need to take advantage of advances in predictive and prescriptive analytics in order to meet the expectations of high reliability in spite of these challenges.

ABB Ability™ Ellipse® APM, formerly known as Asset Health Center, is a solution designed to provide health and performance insights to prevent critical asset failures while optimizing asset life cycle costs. The solution enables utilities to leverage their online and offline data to drive more intelligent, risk-based approaches to asset management in alignment with industry standards such as ISO 55000 and PAS 55.

Ellipse APM can either be installed on premise or delivered as a service via the Microsoft® Azure® cloud and combines ABB's unparalleled technical expertise with collaborative asset performance management workflows on a world-class, secure and extendable analytics platform.

Ellipse APM is the most proven and efficient asset performance management solution available on the market. Its speed of implementation and extendibility allows you to start lean, experiment and learn, and accelerate your organization's digital transition while savings are materialized.

Features and benefits:

- Increased reliability by identifying, prioritizing and resolving risks before they materialize
- Lower maintenance by reducing ineffective time-based practices and expensive failures
- Lower capital expenditures by getting longer economical life out of existing assets
- Structured knowledge capture facilitates job transitions
- More efficient compliance management through lean workflows and embedded reporting



Predictive analytics

AEP, one of the largest electric utilities in the United States, has avoided failures using ABB Ability Ellipse APM's predictive analytics. In one specific example, they saved \$5 million when a transformer began to show rapid gassing (H₂ and acetylene), was taken offline, and the loose leads that would have caused failure were repaired.

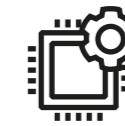

Repair and replace priorities

Most utilities find more work in the backlog than resources to complete it. How do you decide where to start in order to have the most significant impact on overall risk? Though a maintenance prioritization algorithm, Ellipse APM provides a suggested order that enables a risk-optimized maintenance schedule.



Reliability-centered maintenance

RCM programs often take a very long time to show benefits in the electricity transmission environment, partly because failures are not as frequent. ABB has already completed the FMEA and root-cause analysis for EHV and HV equipment, and embedded this knowledge into Ellipse APM. By starting with Ellipse APM, organizations can quickly gain the benefits of RCM without waiting for failures to happen in their own organization.

ABB Ability™ Network Manager™

Operational confidence.

Network Manager SCADA

Network Manager SCADA is the real-time processing platform for successful management of all remote control operations of generation, transmission and distribution systems. The platform addresses the needs of electrical power networks for railways and airports to ensure safe and reliable power supplies. It is also used for multi-utility applications including gas and water networks.

The platform has high availability and performance, supporting multiple redundancies across hardware and software, with an extensive toolbox for adapting to safety procedures and work processes to ensure compliance with transportation safety regulations. It is also possible to include an emergency control center and backup facilities with the highest available cyber security.

Network Manager SCADA ensures secure and efficient energy system operations through advanced operator support, standardized data management and high volume processing of real-time and historical data.

The solution supports all sizes of electrical networks, with large numbers of both mobile and stationary client workplaces. It offers full flexibility to equip each workplace to the appropriate size and number of monitors, alarm actuators and other devices.

Features and benefits:

- Scalable, high-performance, high-availability and cyber-secure SCADA platform
- Open architecture that allows integration with other information technology and operations technology systems
- User interface was designed with operator situational awareness as a top priority
- Ideal for both large and small control room environments running 24x7 operations

ABB Ability™ Network Manager™ EMS

Network Manager EMS is the optimal control center solution to enable secure, efficient and optimized operation of the electric power system. It has an open platform that allows for easy integration with other utility information systems, while maintaining high levels of security. It is the market-leading platform for building control center solutions to manage today's power grids as well as tomorrow's smart grids. Its modular architecture can be tailored to the needs of each company to provide a smooth migration path for future expansion.

The applications are built on an open platform, and can be tuned for real-time control and analysis as well as predictive optimization and planning purposes. These powerful network operation tools facilitate safe and efficient day-to-day operation while minimizing long-term capital expenditures.

Features and benefits:

- Secure and efficient network operation in regulated and deregulated markets
- Improved quality of supply
- Optimal utilization of the transmission network
- ENTSO-E CGMES and CIM compliant
- Advanced visualization and situational awareness for operators, leading to enhanced grid operation
- Continuous monitoring of network stability, minimizing the risk of widespread blackout
- High-fidelity training simulator for advanced operator training under steady-state and dynamic power system conditions, providing information about equipment maintenance and outages



MicroSCADA Pro Historian

Critical and accurate grid information software.

The modern electricity grid is a complex, intelligent mechanism that is indispensable to modern life.



Embedded sensors and intelligent devices provide grid operators with rivers of data, and ABB MicroSCADA Pro Historian's data logging and reporting functionality refines it into valuable reports and analyses. This advanced capability effortlessly collects, archives and enables the observer to visualize and analyze the primary process data. ABB MicroSCADA Pro Historian is the tool that enables you to benefit from critical, accurate grid information. It is the way to understand what has happened, and what is happening in a power grid.

An accurate view of the primary process enables fact-based decision making.

MicroSCADA Pro Historian collects and stores various types of data in a database designed to archive hundreds of thousands of values over long time periods in an accurate and reliable way.

Quickly and easily installs into existing MicroSCADA Pro systems without service interruptions.

Extend your current MicroSCADA Pro system with the historian to start gathering your data and immediately benefit from the advanced analysis possibilities. The historian can safely be connected to a running MicroSCADA Pro system without interruption to the operation.

Intuitive, easy operation ensures full utilization of the capabilities.

The flexibility of the user interface provides enterprise wide ease of use. Various needs from high-level business summary to advanced equipment performance and detailed analysis of the electro-technical behavior are supported.

MicroSCADA Pro Historian makes measurements and trends visible and understandable.

The advanced visualizations allows information to be presented in a clear way. Any user can easily compose new reports and layouts to adapt to every situation.

SDM600

System data manager software.

Between the high-voltage wires and pressurized pipes of a modern utility lies a second, equally-important network.

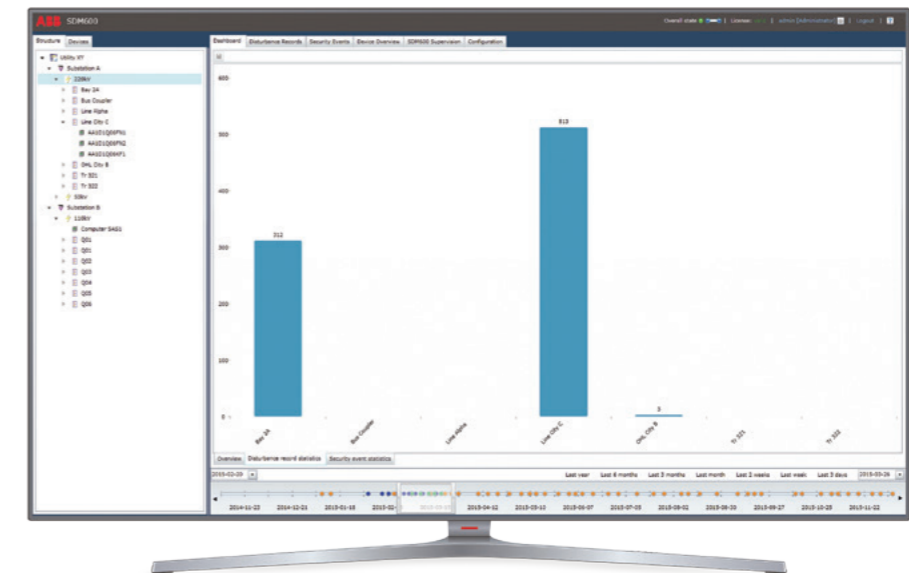

Snaking fiber-optic cables connect SCADA systems that monitor and manage the product delivery, but visualizing this second network requires a new breed of management tool: the SDM600.

Protection relays do the vital work of monitoring the delivery network, but ensuring they're all updated and properly configured has become increasingly burdensome. Now, the SDM600 takes on the job of tracking versions. Using IEC 61850 interfaces, the SDM600 software keeps a watchful eye on protection relays so the user can ensure they're all running the latest software, and to the greatest effect.

With centralized security logging and central account management, SDM600 becomes the gatekeeper to the automation network.

SDM600 also talks to relays when collecting and collating fault records data. The gathered COMTRADE files are recorded into short reports for later analysis, while the SDM600 dashboard presents historical reports so users can see what happened and when with unprecedented ease.

Authenticating users is another task that has ballooned as management networks grow in complexity, and one which SDM600 takes in its stride. Cyber security is a vital component in modern networks, but fragmented directory policies risk exposing critical vulnerabilities that SDM600 can avoid.

Monitoring and diagnostics.

In a digital substation, data becomes easily available for analysis from an operations perspective as well as for maintenance purposes. Ultimately, this allows straightforward implementation of data-driven maintenance strategies like reliability-centered maintenance.

For the precise automatic assessment of HV equipment, condition monitoring systems provide additional key parameters for the asset management system. Examples of such parameters are continuous SF₆ density in a GIS or ablation factor for a generation circuit breaker.

ABB's monitoring systems are applicable for new substations and for retrofitting of existing installations. They map all available data and warning/alarm information via IEC 61850 to the station bus.

Additionally, an embedded web server allows access to the data via an Ethernet port. The port can be connected to a wireless LAN interface, which enables access to the data on handheld devices including tablets or smartphones inside the substation building.

Remote monitoring and real-time visualization of primary equipment via web interface or SCADA.

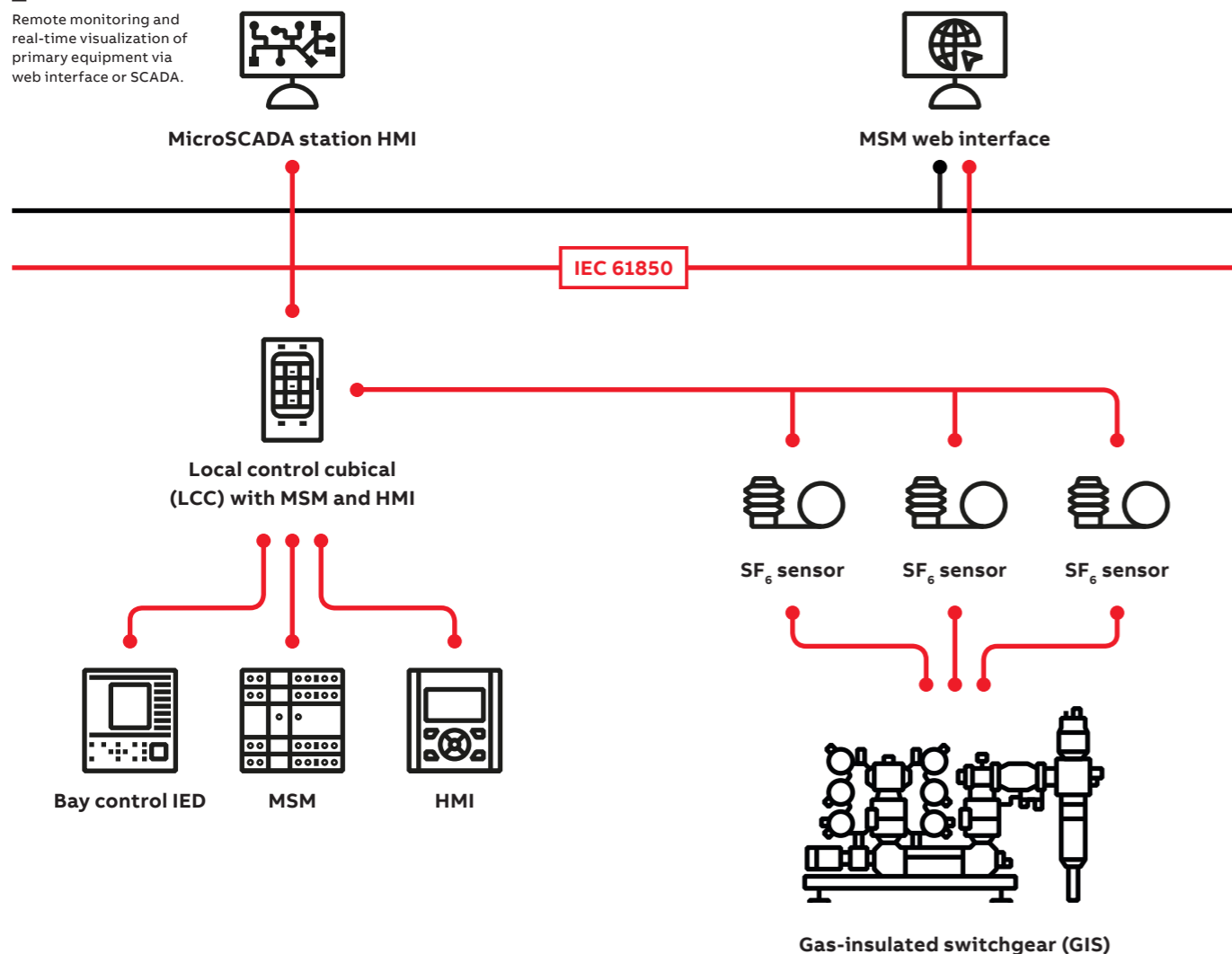

Modular Switchgear Monitoring (MSM)

Modular Switchgear Monitoring (MSM) is an add-on system to continuously supervise SF₆ density in enclosures of high-voltage gas-insulated switchgear. The system is suitable for all kinds of switchgear layouts and operates independently of control and protection devices. MSM is applicable for retrofit of existing substations and for new installations.



Early warnings reduce SF₆ emissions and enable the operator to plan maintenance/repair work. MSM uses SF₆ density sensors based on quartz crystals to directly measure gas density. The sensors have excellent long-term stability performance, identifying leakages long before becoming critical.

Applications

- SF₆ density monitoring in gas-insulated switchgear and metal enclosed breakers:
- Optimize maintenance by using trend calculation
 - Provide data for remote condition monitoring and advanced maintenance strategies

Generator circuit-breaker monitoring system GMS600

State-of-the-art monitoring.

ABB's next-generation monitoring system, GMS600, further enhances generator circuit breaker (GCB) monitoring. It's built on well-established technology that monitors the contact ablation factor. The updated version offers additional, unique features such as SF₆ gas monitoring and trending (GMS600-G), temperature monitoring of primary conductors (GMS600-GT) and enhanced operating drive supervision.



Based on ABB's well-proven Relion Series 650, GMS600-G and GMS600-GT provide an accurate indication of time remaining before the GCB needs servicing, an efficient data-logging system and an intuitive network interface via web client application. They are applicable for retrofit of existing substations and for new installations. GMS600 supports the overall increase of power

plant safety and reliability while enabling cost-effective lifetime management by with ABB's innovative Value Base Customer Care (VBCC) concept. This concept combines sophisticated, prognostic algorithms for analysis of GMS600 data with ABB experts experienced in providing asset-specific service recommendations.

Transformers for digital substations.

ABB transformers for digital substations are equipped with CoreTec™, with unique features for transformer protection, control, monitoring and diagnostics. CoreTec connects to the station by means of a standard IEC 61850 bus.

01 CoreTec

02 CoreSense™ sensor

CoreTec

CoreTec continuously monitors mission-critical transformer functions and traces the history. It simulates various possible operating conditions and forecasts the impact on the transformer's lifecycle.

The system is modular and scalable to cope with present and future requirements, and offers higher functionality than comparable systems.

CoreTec is guaranteed to be maintenance-free for 15 years.

The device is compact and easy to install for new and retrofit installations. Only a few sensors are required and cabling is minimized. No specific additional hardware or software is needed. The unit displays important operating parameters in a user-friendly web interface.

CoreTec is an intelligent, safe and reliable solution for predictive transformer service management. It fits to most transformers and can be used for retrofit.

Key CoreTec features:

- Early detection of malfunctions
- Overload assistance
- Condition assessment
- Improved maintenance planning
- Real time data
- Remote access
- Long-term data storage
- Intelligent status prediction
- Advanced cooling control



01



02

03

Accessories

Oil level indicators

Temperature indicators

Breathers

Buchholz relay

Tap changers

Oil & vacuum

Mechanical and motor drives

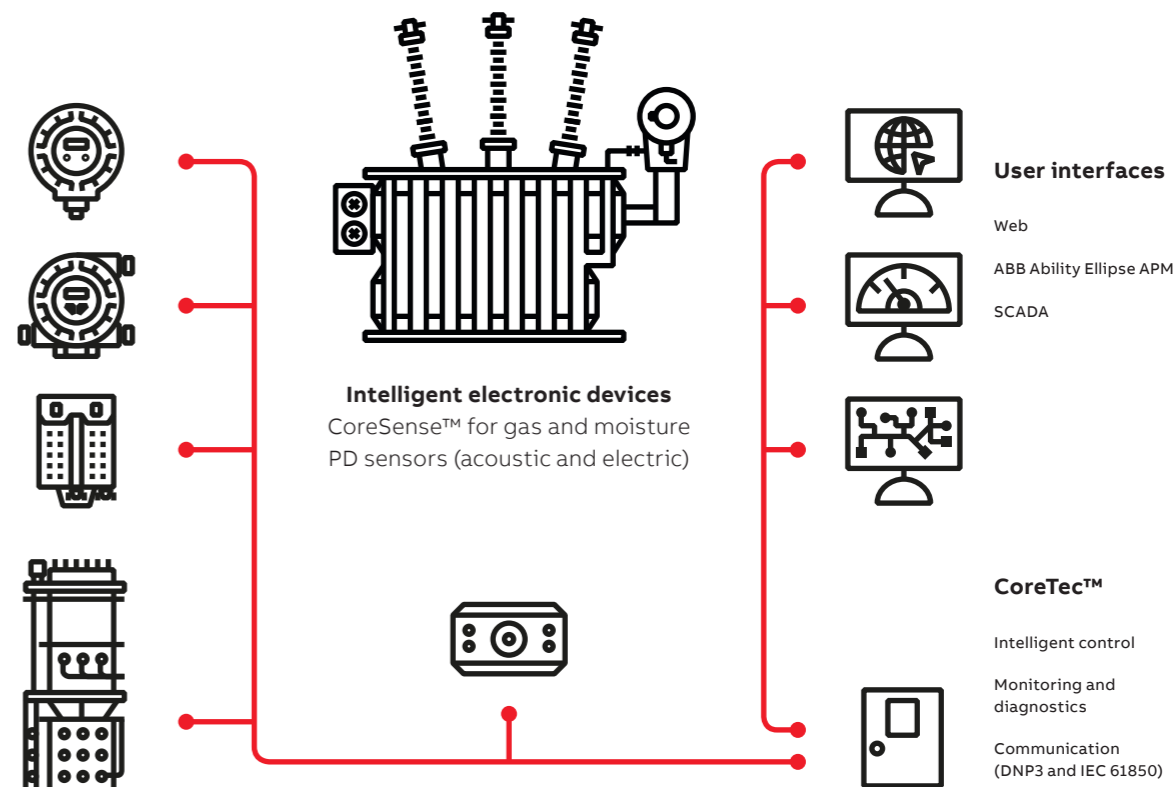

03 Continuous monitoring, control and diagnostics of transformer operations and asset health through CoreTec, web interface, Ellipse APM and SCADA.

CoreSense™

CoreSense continuously monitors hydrogen levels in transformer oil to provide an early warning for most incipient malfunctions. CoreSense also continuously monitors moisture, which has an impact on the insulation system and potentially accelerates aging. CoreSense's hydrogen and moisture readings, combined with ABB's unique experience, enable the recommendation of effective corrective actions.

Intelligence can be provided to individual transformers; however, the greatest benefits are achieved from a whole fleet of transformers, when the transformer status reports are automatically collected by a central dashboard providing a fleet health assessment.

CoreSense™ has no moving parts; it is based on an innovative thermal pump technology. It can be connected to the transformer at any location, including the drain valve. The thermal pump induces the necessary oil flow by convection instead of conventional mechanical pumps, eliminating a common source of failure.

ABB offers reliable online monitoring solutions across multiple industries worldwide and has an extensive installed base of sensors and analyzers. With over 100 years of experience as the leading transformer supplier, ABB has intimate knowledge of how transformers behave. Where other market players provide sensors, ABB provides transformer intelligence.

Key CoreSense™ features:

- Online monitoring of hydrogen in transformer oil based on a novel solid-state hydrogen and moisture sensor (no membrane)
- Easy to download data in .csv format for offline analysis
- Two user-configurable alarm levels, WARNING and ALARM, for both hydrogen and moisture
- Large number of communication protocols and options
- 4-20 mA inputs allow connection from external sensors (i.e., load, ambient temperature or oil temperature)
- Sensor configuration and administration streamlined and intuitive web interface

FOX615

Enabling seamless migration and extension of existing communication infrastructures.

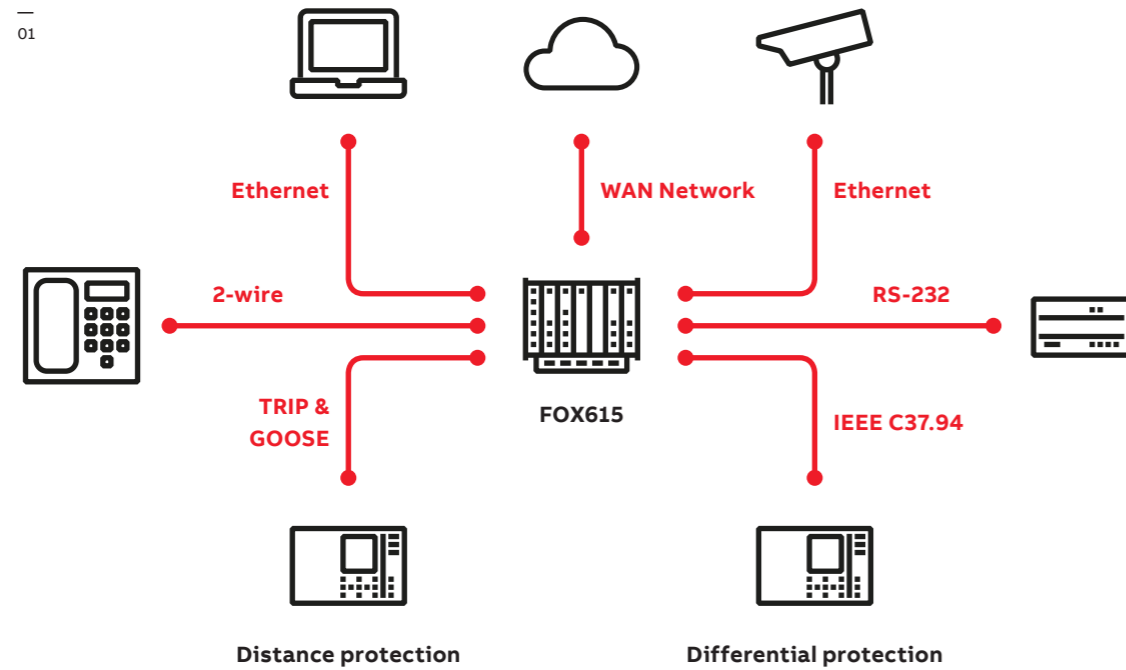

01 FOX615 multiservice platform – guaranteed communication performance for critical applications.

An outstanding multiservice platform for real-time utility communication.

ABB's FOX615 is a hybrid solution supporting traditional TDM (PDH / SDH) and multi-protocol label switching – transport profile (MPLS-TP), the latest standard designed to address the new applications using packet switched technology natively. The majority of existing power utilities communication networks are based on time division multiplexing (TDM), which allocates dedicated circuits to specific communications, thus guaranteeing the required communication performance parameters such as bandwidth, latency and symmetry.

New standards today are based on packet switched technologies (e.g., IEC 60870-5-104 or IEC 61850) and therefore integrate natively into a packet switched MPLS backbone network. Well-known features of SDH networks were left behind when MPLS was originally created for dynamic public telecommunication networks and implemented as IP/MPLS.



SDH

Supported network

Hybrid

Combined networks

MPLS-TP

Future network

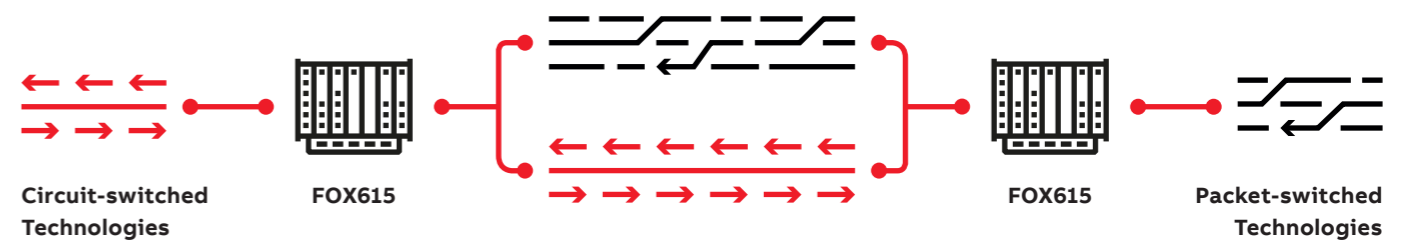

Phase 1

- NG SDH**
Ethernet over SDH
- IEC 104 RTU
 - Voice over IP (VoIP)
 - Video over IP

Phase 2

- Hybrid platforms**
SDH/MPLS-TP
- Non-critical applications on PSN
 - Critical applications remain on TDM

Phase 3

- MPLS-TP**
- IEC 61850 over IP
 - Traditional over IP
 - Critical application on PSN

02 FOX615 allows stepwise migration from SDH to MPLS-TP with guaranteed performance.

That's why an enhancement of the standard was required, leading to MPLS-TP bringing back those missing features from SDH to the MPLS world such as bidirectional and static channel routing or end to end channel supervision using operational administration maintenance (OAM). FOX615 provides native MPLS-TP and SDH functionality as part of the hybrid approach implemented. The combination of state-of-the-art SDH technology and future MPLS-TP technology provides an easy and flexible way to migrate technology in a utility network. All FOX615's that are deployed in the field today can easily be upgraded to MPLS-TP. It also allows the parallel implementation of SDH and MPLS-TP in one node, separating traffic according to their performance requirements. One further option is to just implement a pure MPLS-TP node. FOX615 today offers much more to a utility than any other multiservice platform for real-time utility communications.

FOX615 is designed to be deployed in harsh environment ranging from extreme temperatures to magnetic and electrical fields, which can be

particularly severe during short-circuit events. Furthermore, it includes integrated teleprotection interfaces for distance as well as for differential protection. These interfaces are designed to work in TDM as well as in MPLS-TP networks. Especially the implementation of differential protection over PSN networks imposes huge challenges, as the PSN inherent jitter has to be compensated to guarantee a reliable functionality. FOX615 also uniquely provides highly secure end-to-end encryption in mission-critical networks, while still maintaining the very high level of data availability required for such infrastructures. State-of-the-art encryption is based on keys generated by a hardware-based quantum random number generator for the highest level of assurance.

FOX615 can guarantee the communication channel performance required of those critical applications. Additionally FOX615 provides the possibility to distribute exact time of day information, pass it on to end devices and can help to become more independent of any third party clock source, e.g., GPS.

MicroSCADA Pro

Local and remote control of the substation.

MicroSCADA Pro SYS600 is a modular and scalable software for real-time monitoring and control of primary and secondary equipment in substations.

MicroSCADA Pro is designed with complete functionality for real-time monitoring and control of primary and secondary equipment in transmission and distribution substations. It allows easy and safe interaction with protection and control IEDs, as well as with the process via the operator's workplace, enabling operators to take the right actions and achieve maximized availability of the digital substation.

With MicroSCADA Pro, breakers and disconnectors are operated from a separate control room in the substation, minimizing the



Apparatus safety

MicroSCADA Pro prevents simultaneous operation of primary equipment. It reserves the device and verifies whether the selected object can be operated before executing commands. Additionally, station-wide interlocking schemes, which are complementary to the bay level interlocking, prevent dangerous operations that might otherwise damage primary equipment.



Secure operations

Correct and reliable information is the basis for safe operations. MicroSCADA Pro maximizes information availability by supporting redundant system servers and communication at any substation in every situation.



Optimized maintenance

MicroSCADA Pro allows you to define automatic alarms to optimize maintenance timing by monitoring the number of breaker operations, fault and disturbance statistics, and motor startups.

risk of injury. Notification of ongoing maintenance work can be attached to the process views and a control dialog to inform operators accordingly. MicroSCADA Pro also permits the definition of authorization levels for different user categories to prevent unauthorized actions.

Intuitive and consistent icons with selectable and pre-defined color schemes enhance visual comfort for the operator. This makes it easy to master the overall information displays and get familiar with the system quickly.

RTU500 series

Intelligence distributed across your power grid.



RTU500 series brings the information from the physical power grid to your SCADA system. The modular Remote Terminal Units (RTU) are designed to meet your needs in transmission and distribution automation, enabling you to have the most efficient solution for your requirements.

As with many of ABB's products - RTUs have been designed from the ground up with strong and resilient cyber security enabling you to communicate securely via all forms of networks - offering peace-of-mind and confidence in your network. Functional and hardware extensions can be realized easily and the complete series can be quickly engineered to your needs using our proven software tool enabling greater flexibility and cost savings in training.

Your benefits:

- Secure investment thanks to agile migration concepts as well as functional and software extensions
- Maximum flexibility and adaptability to meet the requirements of today and tomorrow
- Cost-efficient monitoring and control solutions thanks to intuitive and efficient configuration tool
- Eco-efficient solutions for reduced environmental impact, allowing for the integration of renewables into the power grid
- Future-proof RTUs thanks to technological innovativeness and interoperability
- ABB is your long-term partner with more than 40 years' experience in electrical and industrial automation applications
- RTUs incorporate strong and resilient cyber security features for secure



Medium-voltage switchgear for digital substations.

01

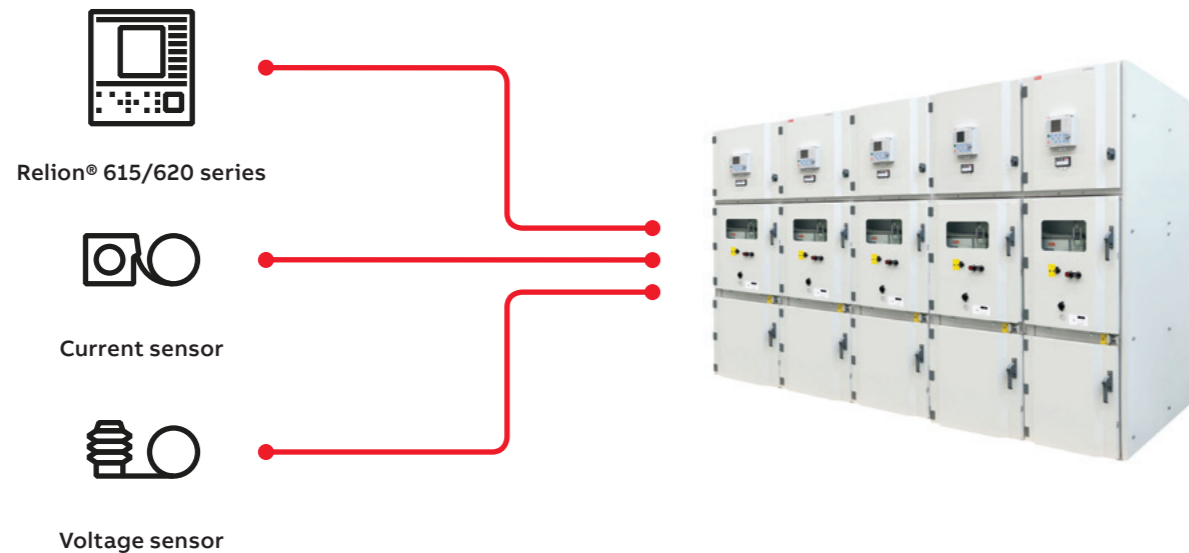

01 Digital switchgear

Digital switchgear

Digital switchgear is a new solution implemented to the traditional metal-clad ANSI switchgear. It is accomplished by using well-proven components such as current and voltage sensors, Relion® protection relays and IEC 61850 digital communication.

The current sensors have a highly compact design, optimized for use in traditional metal-clad ANSI switchgear. Each panel can accommodate two sets of current sensors.

The voltage sensors are very compact as well. They are integrated as part of the support insulators housed in the cable compartment or built directly in the busbar compartment.

The current and voltage sensors are highly accurate (accuracy class 0.5); however, revenue metering might require still higher accuracy classes or the installation of instrument current and voltage transformers for the specific purpose. The transformers can optionally be added to sensor-equipped panels.

Digital switchgear benefits:

- Smart grid flexibility
- Minimizes lifetime costs
- Quick delivery
- Flexibility during switchgear operation
- Reliability and safety
- Space-saving solution
- Green solution
- Customization and changes

Digital switchgear features:

- Covers the entire ANSI medium-voltage, metal-clad product portfolio
- Available for applications up to 27kV, 4000A and 50kA
- Current and voltage sensors with accuracy class 0.5
- Relion protection and control relays with IEC61850-9-2LE

02



02 Current sensors

03 Current measurement in KECA 80 Cxxx sensors is based on the Rogowski coil principle.

Current sensors for digital switchgear

Electronic instrument transformers (sensors) offer an alternative way of making the current measurements needed for the protection and monitoring of medium voltage power systems. Sensors based on alternative principles have been introduced as successors to conventional instrument transformers in order to significantly reduce size, increase safety, and to provide greater rating standardization and a wider functionality range. These well-known principles can only be fully utilized in combination with versatile electronic relays.

ABB's current sensors are constructed without a ferromagnetic core, resulting in several important benefits for the user and the application. The main benefit is that the sensor's behavior is not influenced by non-linearity and width of hysteresis curve, which results in a highly-accurate and linear response over a wide dynamic range of measured quantities.

A linear and highly accurate sensor characteristic in the full operating range enables the combination of metering and protection classes in one winding. With KECA 80 Cxxx sensors measuring class 0.5 is reached for continuous current measurement in the extended accuracy range from 5% of the rated primary current (I_{pr}) not only up to 120% of I_{pr} (as being common for conventional current transformers), but even up to the rated continuous thermal current.

03

Secondary Output

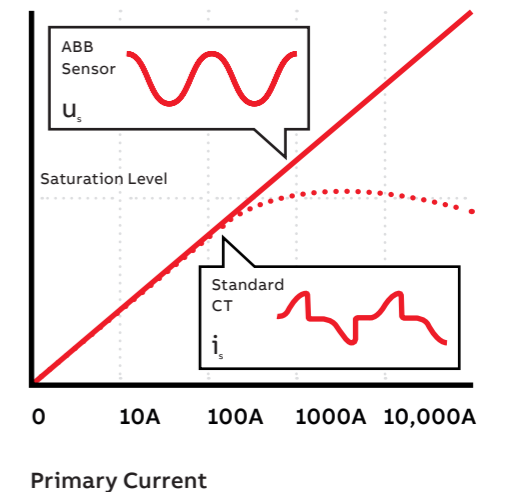

For dynamic current measurement (protection purposes) the ABB sensors KECA 80 Cxxx fulfill requirements of protection class 5P up to an impressive value reaching the rated short-time thermal current I_{th} . That provides the possibility to designate the corresponding accuracy class as 5P630, proving excellent linearity and accuracy measurements.

Current measurement in KECA 80 Cxxx sensors are based on the Rogowski coil principle. A Rogowski coil is a toroidal coil, without an iron core, placed around the primary conductor in the same way as the secondary winding in a current transformer. However, the output signal from a Rogowski coil is not a current, but a voltage.

Current sensors for MV panels features:

- Linear characteristic
- No magnetic core
- Combined accuracy class of 0.5 for metering and 5P630 for protection purposes
- Wide dynamic range reaching values up to rated short-time thermal current
- Very compact mechanical design to better fit into MV switchgear
- Safe secondary outputs

Voltage sensors for digital switchgear.

Electronic instrument transformers (sensors) offer an alternative method of making the voltage measurement needed to protect and monitor medium-voltage power systems.

01



01 Voltage sensors for Digital Switchgear

Sensors based on alternative principles have been introduced as successors to conventional instrument transformers in order to significantly reduce size, increase safety, and to provide greater rating standardization and a wider functionality range. These well-known principles can only be fully utilized in combination with versatile electronic relays.

ABB's voltage sensors are constructed without the use of a ferromagnetic core, resulting in several important benefits for the user and the application. The main benefit is that the behavior of the sensor is not influenced by non-linearity and width of hysteresis curve, which results in a highly-accurate and linear response over a wide dynamic range of measured quantities.

A linear and highly accurate sensor characteristic in the full operating range enables the combination of metering and protection classes in one device. Voltage measurement range for metering accuracy class 0.5 and protection accuracy class 3P.

Voltage measurement in KEVA B sensors is based on the resistive divider principle. The output voltage is directly proportional to the input voltage.

Voltage sensor for MV panels features:

- Compact mechanical design to better fit into MV switchgear
- No ferroresonance phenomena
- Safe secondary outputs
- Only two types covering the voltage range up to 27kV
- No primary fuses required, decreasing maintenance requirements

Arc fault protection.

Innovative arc flash mitigation in less than 4 ms: the highest possible level of arc flash protection for personnel and equipment, maintenance of a secure power supply and the reduction of production stoppages.

02



02 Arc fault protection

The occurrence of an arc fault, the most serious fault within a switchgear system, is mostly associated with extremely high thermal and mechanical stresses in the area concerned. Based on the knowledge gained from decades of experience with the ABB vacuum interrupter and Is-limiter technology, a new active arc fault protection system now helps to effectively avoid these negative effects if a fault should occur.

The ultra-fast earthing switch, UFES™, is a combination of devices consisting of an electronic unit and the corresponding primary switching elements that initiate a three-phase short-circuit to ground in the event of an internal arc fault. The extremely short switching time of the primary switching element in conjunction with the rapid and reliable detection of the fault, ensures that an arc fault is extinguished almost immediately after it arises (extinguishing time < 4 ms after detection).

The UFES electronics are available in two designs. In this portfolio, the electronic detection and tripping unit (DTU) type QRU1 provides an expandable complete solution with internal light and current detection, which is able to monitor small protection areas without any additional devices.

The electronic tripping unit (TU) type QRU100 uses only external detection units for monitoring of the protected area. In this context, the TU suits ideally for the connection to the ABB arc protection system type REA. Compatible and accordingly tested interfaces are available for this purpose.

Arc fault protection features:

- Highest possible level of arc flash protection for personnel and equipment
- Secure power supply
- Ultra-fast earthing switch
- Rapid and reliable detection of faults
- Available in two designs

Relion® 615/620 series

IEDs for protection and control.

01



01 Relion®
615/620 series

Protection and control relays represent the control center of a switchgear panel. UniGear Digital uses the 615 and 620 series types of protection and control relays from ABB's Relion family.

Relion® 615 series IEDs for protection and control

The Relion 615 series of protection relays is a compact and versatile solution for power distribution in utility and industrial applications. The 615 series provides standard configurations, which allows you to easily set up and adapt the configuration according to application-specific needs. The 615 series combines compactness and powerful features in one smart package. The 615 series offers three dedicated product types for UniGear Digital: REF615, REM615 and RED615.

Feeder protection and control REF615

REF615 is a dedicated feeder protection relay perfectly aligned for the protection, control, measurement and supervision of utility and industrial power distribution systems including radial, looped and meshed networks, also involving possible distributed power generation.

Motor protection and control REM615

REM615 is a dedicated motor protection relay perfectly aligned for the protection, control, measurement and supervision of asynchronous motors in manufacturing and process industry. REM615 offers all the functionality needed to manage motor starts and normal operation also including protection and fault clearance in drive and network disturbance situations.

Line differential protection and control RED615

RED615 is a phase-segregated, two-end, line differential protection and control relay. With in-zone transformer support and voltage protection, it is perfectly harmonized for utility and industrial power distribution networks. The RED615 relays communicate between substations over a fiber-optic link or a galvanic pilot wire connection. Protection of ring-type and meshed distribution networks generally requires unit protection solutions, also applied in radial networks containing distributed power generation. With relation to UniGear Digital solution this protection relay will be used for more dedicated applications only.

Relion® 620 series

IEDs for protection and control.

02



02 Relion® 620 series

The Relion 620 series protection relays increase flexibility in demanding utility and industrial applications for power distribution.

They are delivered with example configurations to ease adaptation into your specific applications. The series offers customization possibilities, which supports higher levels of standardization in the applications. The 620 series extends the hardware possibilities further compared to the 615 series.

The 620 series offers two dedicated product types for UniGear Digital: REF620 and REM620.

Feeder protection and control REF620

REF620 is a dedicated feeder IED perfectly aligned for the protection, control, measurement and supervision of utility and industrial power distribution systems, including radial, looped and meshed distribution networks.

Remote I/O unit

RIO600

03 Remote I/O unit
RIO600

The remote inputs/outputs unit RIO600 is designed to expand the digital and analog inputs/outputs of ABB's Relion® protection relays and to provide inputs/outputs for the station automation device COM600 using the IEC 61850 communication.



03



ABB GRID AUTOMATION SERVICE

ABB Grid Automation Service has more than 150 service centers strategically located around the globe. These one-stop shops are staffed by 6,000 professionals with extensive industry and service experience on a wide array of power equipment and systems. Our team of power experts and analysts can help you address today's toughest power challenges and prepare you to meet the challenges of the future.

Relion®

The power of one solution for protection and control.

The Relion® series offers a standardized library of functionality on a high performance, common hardware architecture, and provides the flexibility and configuration to suit any application area.

With its proven reliability, high accuracy and high performance operation, the Relion® series of protection devices can be used for the most demanding applications for your power system network.

The Relion® 670 and 650 series protection and control IEDs (intelligent electronic device) provide versatile functionality as well as maximum flexibility and performance to meet the highest requirements of any application in generation, transmission and sub-transmission protection systems.



Safeguarding your investment

Continuous monitoring and protection of the primary equipment.



Utility grade protection

Electromagnetic compatibility compliant with IEC 60255 and IEEE/ANSI C37.90.



Critical application reassurance

Redundant communication for 100% availability.

Relion® 670 series

IEDs for protection and control.

The Relion 670 series of protection IEDs support IEC 61850-9-2 sampled analog values. All devices can process multiple sample values streams and also operate in mixed configurations with sampled values and conventional wired current and/or voltage signals. The series can have up to six Ethernet ports that can be used for either process bus or station bus, redundant or non-redundant.

The line protection is performed by the REL670 for distance protection and RED670 for line differential protection. Line differential protection supports multi-ended transmission lines with conventional and/or digital current measuring at the remote end substation(s). If permitted by the line differential communication method, the line differential protection can operate without GPS clocks, mirroring conventional setups where the “echo mode” of RED670 is used. The 670 series is IEC 61850-9-3 enabled, as for example RET670 transformer differential protection can either work with all digital currents, measured by NCITs or conventional CTs and digitized by standalone merging units like SAM600, or it can work in mixed configuration with some currents provided as



sampled values and other wired conventionally from traditional CTs.

The phasor measurement unit RES670 is fully compliant with standard for Synchrophasor Measurements for Power Systems, IEEE 1344-1995 and IEEE Std C37.118-2005 (Both measurements and data communication), IEEE Std C37.118.1-2011 and IEEE Std C37.118.1a-2014 (Measurements), IEEE Std C37.118.2-2011 (Data communication) communication capabilities enable easy integration of RES670 in substation automation systems. Several protection and control functions of the Relion 670 series IEDs are available in RES670. In addition to the RES670, the phasor measurement feature is also integrated within the REC670/RED670/REG670/REL670/RET670 products to enable cost-effective, distributed phasor monitoring functionality.

Relion® 650

The Relion 650 series of protection and control IEDs (intelligent electronic devices) provide ready-to-use solutions configured with complete protection functionality, support for IEC 61850-9-2 sampled analog values and default parameters to meet the needs of a wide range of applications.

Key functionality includes:

- Complete and ready-made application solutions
- Up to four Ethernet ports, supporting HSR/PRP and IEC 61850-9-3.
- An HMI with on-screen keyboard, user configurable push buttons and three-color LED indications with programmable LED text-based alarm descriptions, making it easy and fast to work with the IED.
- Minimized parameter setting based on default values and ABB’s global base value concept.

Only parameters related to the application need to be set, such as the line data.

- Centralized account management (CAM), which enables deployment of users, access rights and certificates in the substation automation system in a structured and standardized way.
- Flexible product naming (FPN), which allows the mapping of the standard logical device names, logical node names and attributes to a customer oriented and IED-vendor independent IEC 61850 model.

In the 650 series IEDs, most basic parameters are set before delivery from the factory. You only need to set the parameters specific to your application, enabling you to quickly take your IEDs into operation. The application manual includes setting examples to support your protection engineers.

Relion® REB500

Distributed busbar protection.

For busbar protection and breaker failure protection, ABB offers the REB500 distributed busbar protection system. The REB500 bay units interface to the IEC 61850-9-2 sampled values. The REB500 busbar and breaker failure protection system is designed to work without station-wide

synchronization of analog sampling to provide highest availability of the protection. The distributed busbar protection system can operate with process bus as well as conventional current and voltage values. This enables for example seamless extensions of existing installations.

Application	Type	670	650	REB500
Bay control	REC	•	•	
Busbar protection	Distributed			•
	High impedance		•	
	Centralized	•		
Circuit breaker protection	REQ		•	
Capacitor bank protection	REC	•		
	RET	•		
Generator circuit breaker monitoring	GMS		•	
Generator protection	REG		•	
Overheadline/cable protection	RED	•	•	
	REL	•	•	
Point of wave control	PWC	•	•	
Reactor protection	REB		•	
	RET			
Railway application	RER	•		
Tap changer control	REC	•		
	RET	•	•	
Transformer protection	RET	•	•	
Wide area monitoring	RES	•		

IET600

Integrated engineering tool for ABB Digital Substation.

— 01 Easily define the substation layout using a single line editor with a palette of built-in primary equipment.

— 02 Comprehensive graphical editor for physical network configuration.

Integrated engineering tool for IEC 61850 fully Digital Substation.

The integrated engineering tool IET600 is designed for configuring IEC 61850-based fully digital substation automation systems and applications. IET600 allows system engineers and integrators to define and configure the complete substation automation system according to IEC

61850.

It features powerful graphical interfaces to design the substation topology, manage the communication between all IEC 61850 compliant IEDs in the substation and generate a complete description of the substation in an SCD file. IET600 is the world's first system engineering tool to be IEC 61850 Edition 2 conformance certified.

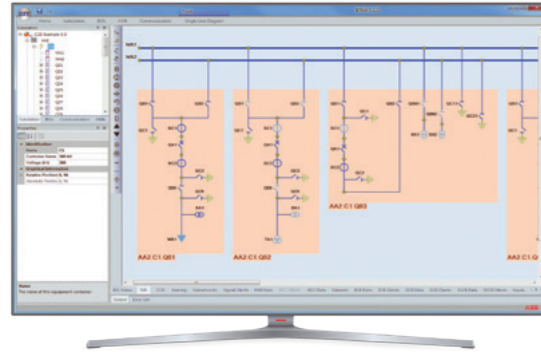

01

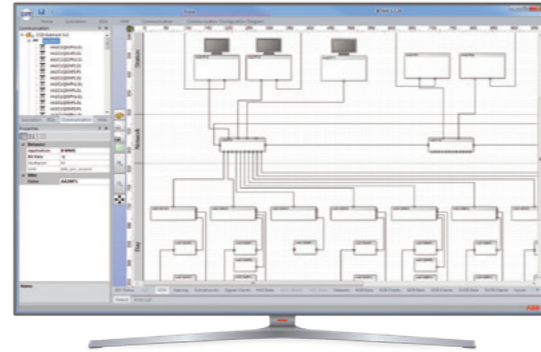

02

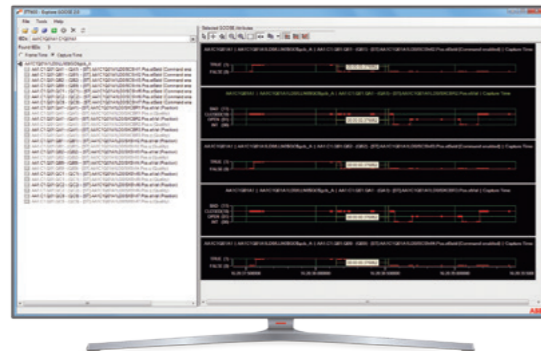

03



04

ITT600

Integrated testing tool for ABB Digital Substation.

— 03 ITT600 makes GOOSE messages visible.

— 04 IEC 61850 9-2 LE stream visualization showing phasor diagrams and RMS values.

The integrated testing tool ITT600 SA Explorer is designed for easy diagnosis and troubleshooting of IEC 61850-based substation automation systems and applications. It features convenient navigation, comprehensive presentation of application data, and support for system consistency check both online and off-line. This allows anybody to use the same tool to analyze and debug substation automation applications regardless of their level of knowledge of IEC 61850 communication.

The ITT600 SA Explorer tool offers facilities for exploring and analyzing the communication configuration of the protection and control IEDs (intelligent electronic devices) and IEC 61850 communication in substation automation systems, including GOOSE messages.

Its versatile functionality eliminates the need for multiple testing tools for different purposes, such as MMS browsers, and protocol and Ethernet analyzers.

The powerful features of ITT600 SA Explorer provide test engineers with access to any IEC 61850-compliant IED. The tool's various functions allow efficient testing of the IED application and isolate the root cause of system communication problems. This significantly reduces testing and commissioning time in a fully digital substation. ITT600 SA Explorer is easy to use, and does not require the skills of a data communication specialist. By translating the complex terminology of communication protocols into the standardized IEC 61850 language, it makes the essential information available to all users.

PCM600

Simplifying management of protection and control IEDs.

— 05 PCM600

PCM600 provides versatile functionalities for the entire life cycle of Relion® protection and control IED applications. This easy-to-handle tool helps you manage your protection and control equipment all the way from application and communication configuration to IED maintenance and service.

PCM600 interacts with IEDs over the fast and reliable TCP/IP protocol via a corporate LAN or WAN, or alternatively directly through the communication port at the front of the IED. It is able to read and write all configuration and setting data of an IED with a single command.

PCM600's unique graphical application configuration concept enables configuration and monitoring of the complete IED application from input to output. The online monitoring allows an easy and fast testing of all protection and control functions.

The IEC 61850 standard-compliant PCM600 allows a seamless integration of Relion IEDs into any IEC 61850 system. PCM600 and Relion IED series are the perfect solution for any protection and control application.

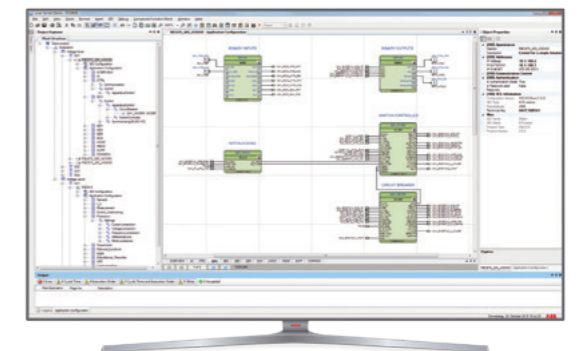

05

SAM600 process bus I/O system.

SAM600 integrates conventional instrument transformers into modern, IEC 61850-9-2 process bus substation automation, protection and control systems.

The modular design of SAM600 enables safe, efficient, and stepwise retrofit of any substation in AIS or GIS technology. In order to maximize the benefits of IEC 61850 process bus, SAM600 modules are placed in marshaling kiosks across the switchyard close to the primary apparatus.

SAM600 bridges the gap between analog and digital worlds and enables the upgrading of existing conventional substations to Digital Substations with IEC 61850 process bus as it interfaces any conventional instrument transformers or primary apparatus

SAM600 supports different communication redundancy architectures according to IEC 62439-3 (HSR/PRP).

Signals such as currents and voltages, and I/O signals from primary apparatus, once digitized, can be made available wherever needed inside the substation and elsewhere to protection and control equipment.

Process bus systems can be tested in the factory, from station automation system down to the process interface units. This minimizes the installation, cabling and commissioning time when deploying the pre-tested system on site.

Constant supervision of all electronic components and digital communication in the substation minimizes the need for periodic maintenance and allows for faster remedial action in case of failure.



SAM600 CT
Connects conventional instrument transformer for current measurements to the IEC 61850-9-2 process bus.



SAM600 VT
Connects conventional instrument transformers for voltage measurements to the IEC 61850-9-2 process bus.



SAM600 TS
Communication redundancy (IEC 62439-3 HSR/PRP) and time synchronization via 1PPS or IEC 61850-9-3.



SAM600-IO

SAM600 enables control of conventional current transformer over IEC 61850-9-2LE from control room with C&P IED.

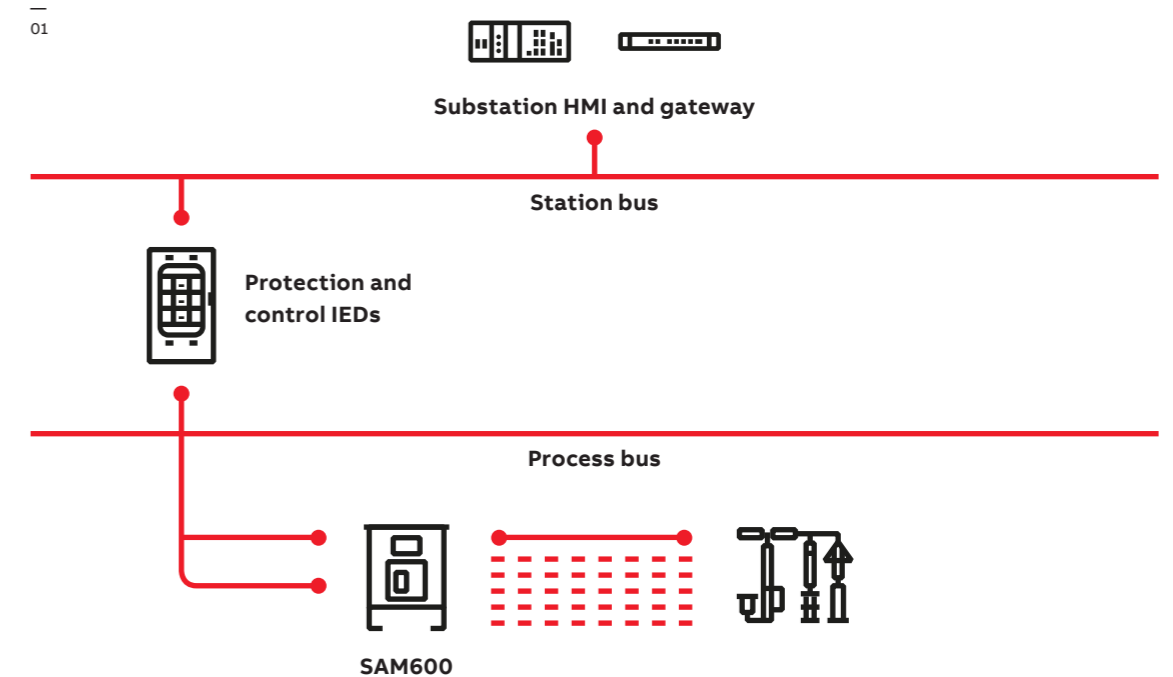

Upgrading

Existing conventional substations can be upgraded to digital substations by introducing a process bus connection.

More efficient project delivery and installation

Reduction of field cabling not only reduces the use of expensive copper, but minimizes engineering efforts, installation and on-site testing.

Unrivaled flexibility

The SAM600 family of products provides IEC 61850 process-level connectivity to conventional current and voltage instrument transformers (SAM600-CT, SAM600-VT), as well as switchyard connectivity of primary apparatus such as circuit breakers, disconnectors and earth switches (SAM600-IO).

Multiple communication ports allow for realizing highly flexible process bus architectures, either in direct point-to-point communication links, or support communication redundancy protocols such as PRP or HSR. Different time synchronization methods are supported, such as 1PPS or IEC/IEEE 61850-9-3.

The SAM600 process bus I/O system works together with next generation sensors, such as ABB's FOCS sensor, combining current measurements with conventional voltage measurements.

Efficient design and operation

Strict adherence to the IEC 61850 standard results in future-proof installations that take advantage of enhanced tool suites for configuration, engineering and testing, such as ABB's PCM600 protection and control IED manager, IET600 system configuration tool and ITT600 SA Explorer for simple and efficient testing.

SAM600 complements ABB's IEC 61850 process bus portfolio from NCIT's for AIS and GIS applications as well as Relion® series protection and control IED's, with process bus interfaces for conventional instrument transformers.

Optimal placement of modules

SAM600 comes in a compact form factor and is DINrail or wall mountable for fast installation and replacement. The modules can be installed in existing protection and control panels, or placed close to primary apparatus in marshaling kiosks in the switchyard. Depending on the number of primary apparatus to be interfaced, SAM600-IO comes in form factors 1/2 19" and 1/1 19", offering the possibility to adapt optimally to the number of primary apparatus to be controlled and monitored.

Safe and simple testing and maintenance

Customizable terminals allow the use of standard cables, tools and work procedures. This reduces the time needed for installation, testing and maintenance activities.

Innovative high-voltage gas-insulated switchgear with combined current and voltage sensors (CP series).

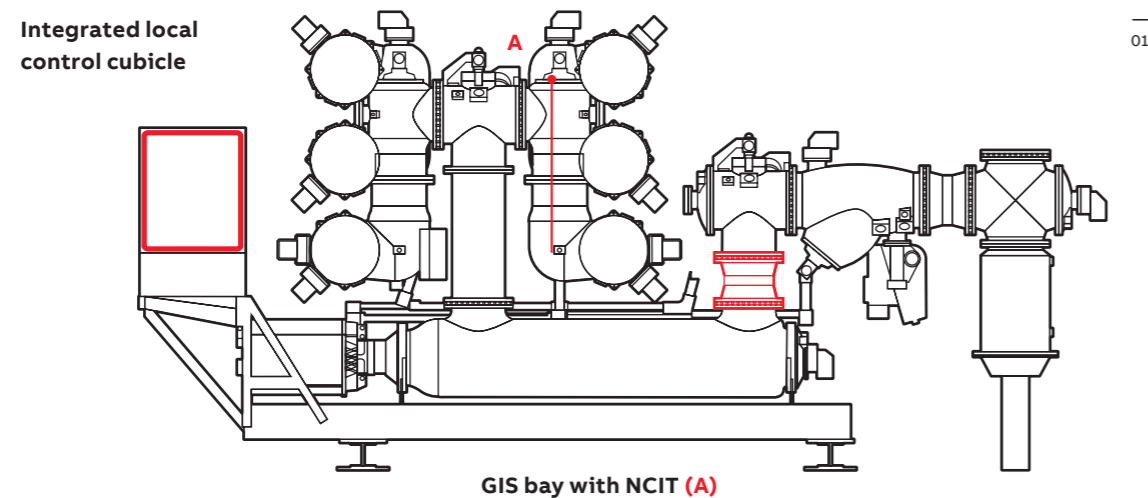

01 High-voltage gas-insulated switchgear

ABB's digital GIS comes integrated with non-conventional instrument transformers (NCIT), that increase operational safety, simplify switchgear design and reduce switchgear footprint. The IEC 61850 process bus replaces conventional copper cabling between local control cubicle and protection cubicle.

The measurement signals are provided by two redundant Rogowski coils for the current and 2 redundant capacitive ring sensors for the voltage. The low-power analog signals from these sensors are converted to a digital signal in redundant electronic modules mounted directly at the sensor. The sensors are sealed for life and repair or replacement during the lifecycle of the primary equipment is not needed. Nevertheless, the electronics mounted on the sensor enclosure are pluggable and can be changed easily.

The NCITs' digital signals are collected by a merging unit and broadcast to protection IEDs via the process bus based on the IEC 61850-9-2 standard. Contrary to conventional CTs, the dynamic range and accuracy of the sensors cover metering, measurement and protection requirements and therefore the engineering process can be simplified.

The control IEDs are mounted in the control cubicle at the GIS bay where all the binary signals to and from switches for a bay are connected and from there the signals are broadcast by means of a process bus. Alternatively, the protection IEDs can be integrated in the local control cubicle as well. The ABB metal-enclosed circuit breakers NCIT merging unit was the world's first to be conformance-certified by the UCA International Users Group.

With multiple Ethernet ports and connections to NCITs, it offers high flexibility to system design or any switchgear layout and provides largely failsafe communication networks between NCITs and control/protection IEDs. This arrangement eliminates most of the point-to-point signaling wires between the bay cubicle, the protection and to the station level.

The NCITs for metal-enclosed switchgear have been in service in substations since 1998 and have proven to be reliable in service and stable under extreme climatic conditions (high temperatures, outdoor applications). Electronic components have been MEOST (multiple environmental overstress test) tested and optimized – in fact, more than 300 systems have been in continuous operation for more than 10 years.

Non-conventional instrument transformers (NCITs) for metal-enclosed switchgear.



Conventional CTs and VTs will gradually be replaced by electronic CT and VT (ECT/EVT)

ABB offers the NCIT CP sensor based on the Rogowski coil principle and on voltage capacitive dividers for metering, protection and control accuracy in a single device. The CP sensor can be physically integrated into metal enclosed switchgear like GIS, DTB (dead tank circuit breakers), hybrid switchgear and MFM (multi-functional modules).

Conventional CTs saturate at high currents, so various sizes of CTs are needed to cope with protection, measurement and metering. The dynamic range and accuracy of NCITs covers the entire functional range with one sensor.

A redundant set of Rogowski coils and the capacitive voltage sensors are integrated in a concentric HV switchgear conductor segment, the sensors are redundant by installing two separate systems. The analog signals are converted to digital and processed directly at the sensor.

CP-MU merging unit for protection and control

The CP-MU merging unit combines and synchronizes the current and voltage measurements from the sensors on the individual phases to IEC 61850-9-2 process bus information.

- World's first UCA-certified IEC 61850-9-2LE compliant merging unit
- Interfaces with sensors of up to three three-phase measuring points
- Reducing the number of components in 1 1/2 breaker and double busbar arrangements
- Multiple Ethernet ports bring high flexibility to system design
- Reduces the need for Ethernet switches in protection circuits

Innovative high-voltage hybrid switchgear.

PASS (plug and switch system).

The PASS for digital substations is a compact hybrid switchgear fully assembled and high-voltage tested in factory, for rapid installation and energization. PASS can leverage digital substation features such as the Motor Drive™ and an intelligent local control cabinet fully enabled with IEC 61850 communication protocol.

01 PASS switchgear with Motor Drive™ and IEC 61850 support.

Motor Drive™

Motor Drive™ 1.4 is a digitally-controlled servomotor that drives the contacts of a high-voltage circuit-breaker contacts with the highest precision, while the energy necessary to enable the operations is stored in capacitors. The input/output (I/O) and interlocking of the PASS module are managed by electronic boards, which can be easily configured at any stage of the project. The switchgear is equipped with an electronic local control cabinet which enables the high voltage switching bay to be operated digitally with a human-machine interface.

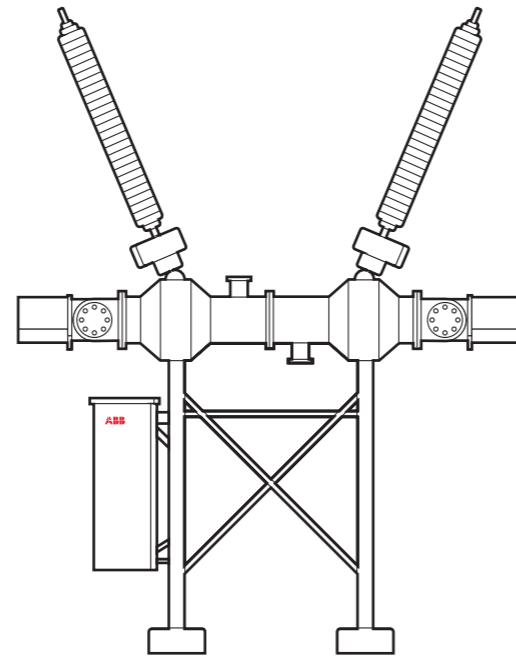

01

Innovative high-voltage switchgear.

Motor Drive™ operating mechanism.

02 Motor Drive™ operating mechanism.

Intelligent local control cabinet (I-LCC)

The I-LCC embeds the configurable logic needed to integrate typical local control cabinet components (e.g., interlocking) and to control auxiliary devices. It also guarantees smooth integration into substation automation systems using IEC 61850, bringing the technology to continuously monitor the functions of the switchyard, while performing real-time simulation and diagnostics, allowing proactive management of the lifecycle of the asset and remote service intervention.

Operating features include:

- Low operation forces
- Simple installation without adjustment
- Advanced self-monitoring system
- Only one moving part in the drive
- Low stable power consumption
- Extremely low noise level

Diagnostics

Motor Drive™ collects and stores a wide array of data that can be downloaded and analyzed. Stored events of the circuit breaker's activities and detailed information about the latest operations are available. Motor Drive's supervisor and diagnostic module verifies that the system is working correctly, continuously monitoring:

- The function of all boards and internal supplies
- The integrity of interlocking
- The functionality of motor control chain

The auto-monitoring functionality, together with the dramatic reduction of mechanically moving parts, gives outstanding reliability, and has been tested for 30000 close/open operations.



02

Innovative high-voltage air-insulated switchgear (AIS) with fiber optic current sensor (FOCS).

ABB's fiber optic current sensor (FOCS) integrates into the IEC 61850-9-2 process bus system, supplying protection and control IEDs as well as revenue meters with accurate current measurements.

01 Integration of fiber optic current sensor.

An AIS solution for digital substations with integrated FOCS is available for both ordinary LTB (live tank breakers) and disconnecting circuit breaker (DCB). The DCB provides the functions of a circuit breaker and a disconnector combined in a single unit, thus giving three functions in one device: measurement, interruption and isolation.

Integrating the FOCS into live tank circuit breaker solutions provides the following advantages:

- Faster installation times; plug and play.
- One FOCS replaces many CT cores, simplifying design and engineering substations
- Lower environmental impact
- More intelligent protection and control due to smart process bus interface
- Compact solution

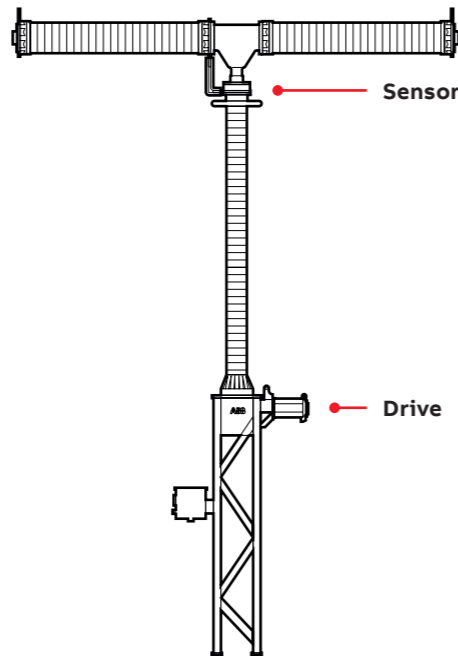

DCB with integrated FOCS

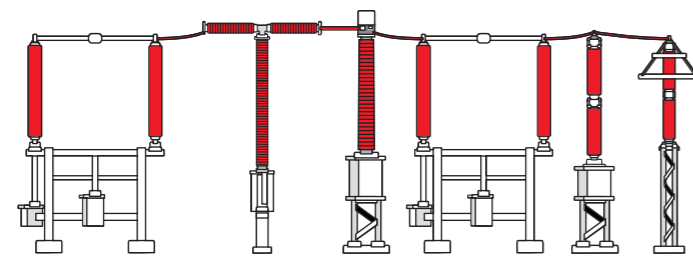

Conventional AIS bay

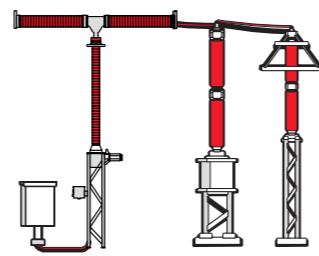

DCB with FOCS

01

Free-standing fiber optic current sensor (FOCS-FS).

FOCS-FS is the free-standing version of ABB's FOCS technology. It is a non-conventional instrument transformer enabling digital HV substations and smart grids with an optical IEC 61850-9-2LE Ethernet output.

02 FOCS-FS

Beside oil- or SF6-insulated inductive current transformers, ABB has developed optical current sensors since the 1990s, based on the Faraday effect principle, whereby light is used to deduce the precise magnitude of current that is creating the magnetic field. As a result, the design is inherently free of magnetic saturation and is therefore suitable for capturing fast-transient currents, short-circuit currents, and alternating current (AC) with DC-offset.

FOCS-FS is a three-phase sensor system consisting of:

- Three hollow insulators filled with nitrogen at ambient pressure and supporting the sensor heads
- One outdoor kiosk, installed on the steel structure of the central phase and connected via optical fiber to the three HV columns and to the relay house via a duplex ethernet optical cable (IEC61850-9-2LE protocol)
- An opto-electronic module located in the kiosk:
 - Sends polarized light to the sensor
 - Receives the reflecting polarized light from the sensor
 - Compares in close-loop control the phase displacement in the polarized light in proportion to the magnetic field and the primary current
 - Converts the result into an optical IEC 61850 Ethernet output

The level of redundancy that can be specified is given by the number of opto-electronics units integrated in the system.

All solutions can be equipped on request with merging units, which digitalize analog signals coming from voltage transformers, synchronize those signals with the digital signal coming from FOCS-FS and consolidate both signals into a digital output stream complying with IEC61850-9-2 LE protocol.



02

ABB Power Grids service.

Your strategic partner for a changing world.

We may not make the world go round, but ABB's Global Customer Care team does its part to keep it running. Through our four key pillars of focus, we provide ongoing technical and functional support to help you meet your objectives.

Rapid response

When something goes wrong, you need it fixed fast! Whether it's spare parts, replacement equipment, or repairs, our care agreements are tailored to your needs. Our remote services and 24/7 call center also provides quick troubleshooting and root-cause analysis services so you can identify the most effective course of action and address problems before they grow.

Operational efficiency

Need to modernize or address a sticky issue? Our consultants can help you assess the challenge and design cost-effective, fit-for-future solutions. In addition, we offer a wide range of commercial and proprietary enterprise-level applications to help you improve operational efficiency.

Performance improvement

Hitting key performance targets can be tough to do when you're trying to keep costs under control. Our team can devise solutions that help you hit your targets as well as provide software applications that deliver actionable insights for future performance improvements.

Lifecycle management

Cradle to grave, Power Grids Service is there to help you take care of your assets by providing installation and commissioning services, maintenance, replacements, spare parts and consumables, and training. We can also help you extend the life of your assets with extensions, upgrades, and retrofits. When it's time to retire an asset, we offer end-of-life services that help you do so cost-effectively and responsibly.

We are with you around the world

ABB Power Grids Service has more than 150 customer care centers strategically located around the globe. These one-stop shops are staffed by 6,000 professionals with extensive industry and service experience on a wide array of power equipment and systems. Our team of power experts and analysts can help you address today's toughest power challenges and prepare you to meet the challenges of future.

We are protection
for your investments. }





—

ABB Switzerland Ltd.

Power Grids

Grid Automation

Bruggerstrasse 72

CH-5400 Baden, Switzerland

Phone: +41 84 484 58 45
(Customer Support Center)

www.abb.com/digitalsubstations