

MANUAL

LB8106*/FB8206* **EasyCom Com Unit for** **PROFIBUS DP/DP-V1**

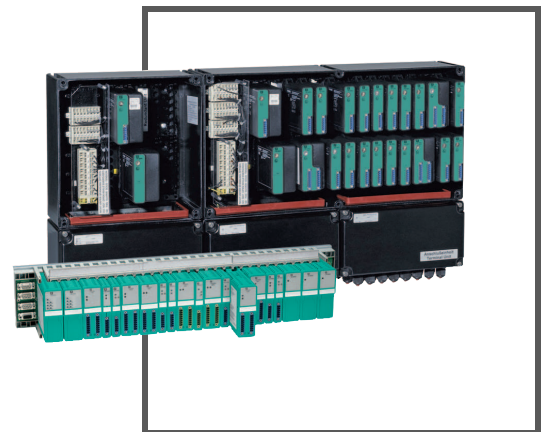

With regard to the supply of products, the current issue of the following document is applicable: The General Terms of Delivery for Products and Services of the Electrical Industry, published by the Central Association of the Electrical Industry (Zentralverband Elektrotechnik und Elektroindustrie (ZVEI) e.V.) in its most recent version as well as the supplementary clause: "Expanded reservation of proprietorship"

1	Introduction.....	12
1.1	Content of this Document	12
1.2	Target Group, Personnel.....	12
1.3	Symbols Used	13
2	Basics of the Remote I/O Systems.....	14
3	Maximum Number of Channels and I/O Modules.....	15
4	Configuring the Com Unit via the Class 1 Master	19
4.1	Setting the PROFIBUS Address.....	19
4.2	Configuration via the Service Bus and PROFIBUS Class 2 Master.....	20
4.3	Configuration via PROFIBUS DP	20
4.3.1	Configuration with "Set_Prm"	20
4.3.2	Setting the Parameters.....	21
4.3.3	Setting the Watchdog.....	22
4.3.4	Scaling, Status Bits, and Cross-Talk Suppression.....	22
4.3.5	HART Parameters.....	24
4.3.6	Power Supply Monitoring	25
4.3.7	Hot Configuration in Run (HCiR).....	25
4.3.8	Preferred Parameter Values	26
4.4	Setting Redundancy Com Units	26
4.5	Advanced Diagnostics.....	27
4.6	Meaning of the DP Configuration String	28
4.7	Structure of the Global Status Register	31
4.7.1	Example of Global Status Register.....	32
4.8	Command Register	33
4.9	Electrical Testing of Connections	33
4.10	Commissioning of the Remote I/O Station.....	34
4.11	Replacing or Adding Com Units	35

5	Configuring the Com Unit via the Device Type Manager (DTM)	37
5.1	Communication with Remote I/O Station	37
5.1.1	Service Bus Connection via RS-232	39
5.1.2	Service Bus Connection via USB	39
5.2	Creating a New Project	40
5.3	Integrating the Service Bus Communication DTM	40
5.4	Integrating the PROFIBUS Communication DTM	42
5.5	Adding Com Units	43
5.6	Editing Com Unit Device Data	46
5.7	Integrating I/O Modules	46
5.8	Converting I/O Module Type Retroactively	48
5.9	Configuring HART Communication	48
5.10	Displaying and Editing Parameters	52
5.10.1	Activating and Deactivating the Configuration Mode	52
5.10.2	Loading and Displaying Parameters	53
5.10.3	Changing Com Unit Parameters	53
5.10.4	Changing I/O Module Parameters	60
5.11	Displaying Measured Values and Diagnostic Data	71
5.11.1	Measured Values Display of Digital I/O Modules	71
5.11.2	Measured Values Display of Analog I/O Modules	74
6	Configuring I/O Modules	76
6.1	Configuring Dual Width I/O Modules	76
6.2	Setting Substitute Values for Fault Occurrences	77
6.3	HART Communication	78
6.4	LB1*01, FB1*01 Digital Input	79
6.4.1	Description	79
6.4.2	Measuring Time and Cycle Time	79
6.4.3	Data Transfer	79
6.4.4	Line Fault Detection	80
6.4.5	Editing Device Data	80

6.5	LB1*02, FB1*02 Digital Input	82
6.5.1	Description.....	82
6.5.2	Measuring Time and Cycle Time	82
6.5.3	Data Transfer.....	82
6.5.4	Line Fault Detection	83
6.5.5	Editing Device Data.....	83
6.6	LB1*03, FB1*03 Frequency/Counter Input	85
6.6.1	Description.....	85
6.6.2	Measuring Time and Cycle Time	85
6.6.3	Data Transfer.....	86
6.6.4	Line Fault Detection	87
6.6.5	Function Types.....	87
6.6.6	Direction Detection	88
6.6.7	Editing Device Data.....	89
6.7	LB 1007 Digital Input	93
6.7.1	Description.....	93
6.7.2	Measuring Time and Cycle Time	93
6.7.3	Data Transfer.....	93
6.7.4	Line Fault Detection	94
6.7.5	Editing Device Data.....	95
6.8	LB1*08, FB1*08 Digital Input	97
6.8.1	Description.....	97
6.8.2	Measuring Time and Cycle Time	98
6.8.3	Data Transfer.....	98
6.8.4	Line Fault Detection	99
6.8.5	Editing Device Data.....	99
6.9	LB1*09, FB1*09 Digital Input	101
6.9.1	Description.....	101
6.9.2	Measuring Time and Cycle Time	102
6.9.3	Data Transfer.....	102
6.9.4	Line Fault Detection	103
6.9.5	Editing Device Data.....	103

6.10	LB1014, LB1015 Digital Input	106
6.10.1	Description	106
6.10.2	Measuring Time and Cycle Time	106
6.10.3	Data Transfer	106
6.10.4	Line Fault Detection.....	107
6.10.5	Editing Device Data.....	107
6.11	LB20*, LB21*, FB22* Digital Output with Position Feedback	109
6.11.1	Description	109
6.11.2	Measuring Time and Cycle Time	110
6.11.3	Data Transfer	110
6.11.4	Line Fault Detection.....	111
6.11.5	Watchdog	111
6.11.6	Editing Device Data.....	111
6.12	LB3101, FB3201 Transmitter Power Supply, Current Input	114
6.12.1	Description	114
6.12.2	Resolution	114
6.12.3	Measuring Time and Cycle Time	114
6.12.4	Data Transfer	115
6.12.5	Line Fault Detection.....	115
6.12.6	Editing Device Data.....	115
6.13	LB3*02, FB3*02, LB3103, FB3203 HART Transmitter Power Supply, current input	117
6.13.1	Description	117
6.13.2	Resolution	118
6.13.3	Measuring Time and Cycle Time	118
6.13.4	Data Transfer	118
6.13.5	Line Fault Detection.....	118
6.13.6	Editing Device Data.....	119
6.14	LB3104, FB3204 Transmitter Power Supply, Current Input LB3*05, FB3*05 HART Transmitter Power Supply, Current Input.	121
6.14.1	Description	121
6.14.2	Resolution	122
6.14.3	Measuring Time and Cycle Time	122
6.14.4	Data Transfer	122
6.14.5	Line Fault Detection.....	123
6.14.6	Editing Device Data.....	123

6.15	LB3*06 HART transmitter power supply	126
6.15.1	Description.....	126
6.15.2	Measuring Time and Cycle Time	126
6.15.3	Data Transfer.....	126
6.15.4	Line Fault Detection	127
6.15.5	Editing Device Data.....	127
6.16	LB4101, FB4*01 Current Output	
	LB4*02, FB4*02 HART Current Output	129
6.16.1	Description.....	129
6.16.2	Resolution.....	130
6.16.3	Measuring Time and Cycle Time	130
6.16.4	Data Transfer.....	130
6.16.5	Line Fault Detection	131
6.16.6	Watchdog	131
6.16.7	Editing Device Data.....	131
6.16.8	Configuring Strain Gauge Measurement	133
6.17	LB4104, FB4204 Current Output	
	LB4*05, FB4*05 HART Current Output	134
6.17.1	Description.....	134
6.17.2	Resolution.....	135
6.17.3	Measuring Time and Cycle Time	135
6.17.4	Data Transfer.....	135
6.17.5	Line Fault Detection	137
6.17.6	Watchdog	137
6.17.7	Editing Device Data.....	137
6.18	LB4106 HART Current Output.....	139
6.18.1	Description.....	139
6.18.2	Resolution.....	140
6.18.3	Measuring Time and Cycle Time	140
6.18.4	Data Transfer.....	140
6.18.5	Line Fault Detection	141
6.18.6	Watchdog	141
6.18.7	Editing Device Data.....	141

6.19	LB5*01, FB5201 RTD Converter	143
6.19.1	Description	143
6.19.2	Resolution	143
6.19.3	Measuring Time and Cycle Time	143
6.19.4	Data Transfer	144
6.19.5	Line Fault Detection.....	144
6.19.6	Editing Device Data.....	144
6.20	LB5*02, FB5202 Thermocouple Converter	147
6.20.1	Description	147
6.20.2	Resolution	147
6.20.3	Measuring Time and Cycle Time	148
6.20.4	Data Transfer	148
6.20.5	Line fault detection	148
6.20.6	Editing Device Data.....	149
6.20.7	Configuring Strain Gauge Measurement.....	151
6.21	LB5*04, FB5204 RTD Converter	153
6.21.1	Description	153
6.21.2	Resolution	153
6.21.3	Measuring Time and Cycle Time	153
6.21.4	Data Transfer	154
6.21.5	Line Fault Detection.....	154
6.21.6	Editing Device Data.....	155
6.22	LB5*05, FB5205 Thermocouple Converter	158
6.22.1	Description	158
6.22.2	Resolution	158
6.22.3	Measuring Time and Cycle Time	158
6.22.4	Data Transfer	159
6.22.5	Line Fault Detection.....	159
6.22.6	Editing Device Data.....	159
6.23	LB5*06, FB5206 Voltage Converter.....	163
6.23.1	Description	163
6.23.2	Resolution	163
6.23.3	Measuring Time and Cycle Time	163
6.23.4	Data Transfer	163
6.23.5	Line Fault Detection.....	164
6.23.6	Editing Device Data.....	164

6.24	LB6101, FB6301 Relay Contact Output	166
6.24.1	Description.....	166
6.24.2	Measuring Time and Cycle Time	166
6.24.3	Data Transfer.....	166
6.24.4	Line Fault Detection	167
6.24.5	Watchdog	167
6.24.6	Editing Device Data.....	167
6.25	LB6005, FB6305 Relay Contact Output	169
6.25.1	Description.....	169
6.25.2	Measuring Time and Cycle Time	169
6.25.3	Data Transfer.....	169
6.25.4	Line Fault Detection	170
6.25.5	Watchdog	170
6.25.6	Editing Device Data.....	171
6.26	LB6006, FB6306 Relay Contact Output	172
6.26.1	Description.....	172
6.26.2	Measuring Time and Cycle Time	172
6.26.3	Data Transfer.....	172
6.26.4	Line Fault Detection	174
6.26.5	Watchdog	174
6.26.6	Editing Device Data.....	174
6.27	LB6*08, FB6*08 Digital Output	176
6.27.1	Description.....	176
6.27.2	Measuring Time and Cycle Time	177
6.27.3	Data Transfer.....	177
6.27.4	Line Fault Detection	178
6.27.5	Watchdog	178
6.27.6	Editing Device Data.....	178
6.28	LB6*10 ... LB6115, FB6210 ... FB6215 Digital Output	180
6.28.1	Description.....	180
6.28.2	Measuring Time and Cycle Time	181
6.28.3	Data Transfer.....	181
6.28.4	Line Fault Detection	182
6.28.5	Watchdog	182
6.28.6	Editing Device Data.....	182

6.29	LB6*16, FB6216, LB6*17, FB6217 Digital Output	184
6.29.1	Description	184
6.29.2	Measuring Time and Cycle Time	184
6.29.3	Data Transfer	184
6.29.4	Line Fault Detection	185
6.29.5	Watchdog	185
6.29.6	Editing Device Data	185
6.30	LB7*04, FB7*04 Universal Input/Output (HART)	187
6.30.1	Description	187
6.30.2	Measuring Time and Cycle Time	187
6.30.3	Data Transfer	187
6.30.4	Line Fault Detection	189
6.30.5	Watchdog	189
6.30.6	Editing Device Data	189
7	Com Unit Diagnostics Functions	192
7.1	Data Transfer	192
7.2	Opening the measured value display of the Com Unit	192
7.3	Layout of the Measured Values Display	193
7.4	Global Status Register	194
7.4.1	Structure of the Global Status Register	194
7.4.2	Example of Global Status Register	195
7.5	"Diagnostics Register" Tab	197
7.5.1	DP Configuration	197
7.5.2	DP Diagnostics	198
7.5.3	DP Parameters	202
7.5.4	Redundancy Status	203
7.5.5	Status Register	204
7.5.6	Type Register	208
7.5.7	Advanced Diagnostics	209
7.6	"PB Diag. (Hrs.)" Tab	210
7.7	"PB Diag (Ext.)" Tab	212

7.8	"Com Unit Diag." Tab.....	213
7.8.1	"Com Unit Status Register" Area.....	214
7.8.2	"GW Status" Area.....	215
7.8.3	"DP status" area.....	217
7.9	"Module Status" Tab	217
7.10	PACTware™ Device State Manager.....	218
8	Troubleshooting.....	222
8.1	Communication error.....	222
8.2	Redundancy Faults	223
8.3	Faults Indicated by LEDs.....	224
8.4	Signal Fault.....	225
8.5	Faults and their effects	227

1 Introduction

1.1 Content of this Document

This document contains information required to use the finished device or system in the relevant phases of the product life cycle. This may include information on the following:

- Product identification
- Delivery, transport, and storage
- Assembly and installation
- Commissioning and operation
- Maintenance and repair
- Troubleshooting
- Dismounting
- Disposal



Note!

This document does not replace the instruction manuals for the components in use. The safety information for the components in use determines the specific safety instructions that apply to the system. The instruction manuals for the components in use must have been read and understood.



Note!

For complete information about the components in use, refer to the instruction manuals and further documentation available online at www.pepperl-fuchs.com.

The documentation comprises the following parts:

- This software manual
- Hardware manual for the remote I/O system in use
- Instruction manuals for the components in use
- Data sheets for the components in use

In addition, the documentation may comprise the following parts, if applicable:

- EC-type examination certificate
- EC declaration of conformity
- Attestation of conformity
- Certificates
- Control drawings
- Other documents

1.2 Target Group, Personnel

Responsibility for planning, assembly, commissioning, operation, maintenance, and dismounting lies with the plant operator.

Only appropriately trained and qualified personnel may carry out mounting, installation, commissioning, operation, maintenance, and dismounting of the product. The personnel must have read and understood the instruction manual and the further documentation.

Prior to using the product make yourself familiar with it. Read the document carefully.

1.3 Symbols Used

This document contains symbols for the identification of warning messages and of informative messages.

Warning Messages

You will find warning messages, whenever dangers may arise from your actions. It is mandatory that you observe these warning messages for your personal safety and in order to avoid property damage.

Depending on the risk level, the warning messages are displayed in descending order as follows:



Danger!

This symbol indicates an imminent danger.

Non-observance will result in personal injury or death.



Warning!

This symbol indicates a possible fault or danger.

Non-observance may cause personal injury or serious property damage.



Caution!

This symbol indicates a possible fault.

Non-observance could interrupt the device and any connected systems and plants, or result in their complete failure.

Informative Symbols



Note!

This symbol brings important information to your attention.



Action

This symbol indicates a paragraph with instructions. You are prompted to perform an action or a sequence of actions.

2 Basics of the Remote I/O Systems

Remote I/O units are signal modification devices that act as an interface for signals between the field devices and the process control systems. The I/O modules are mounted on the prefabricated backplanes using slots. Com units are available for various standard buses and form the interface between the I/O modules and the process control system. Power supplies are used to power the I/O modules and com units.

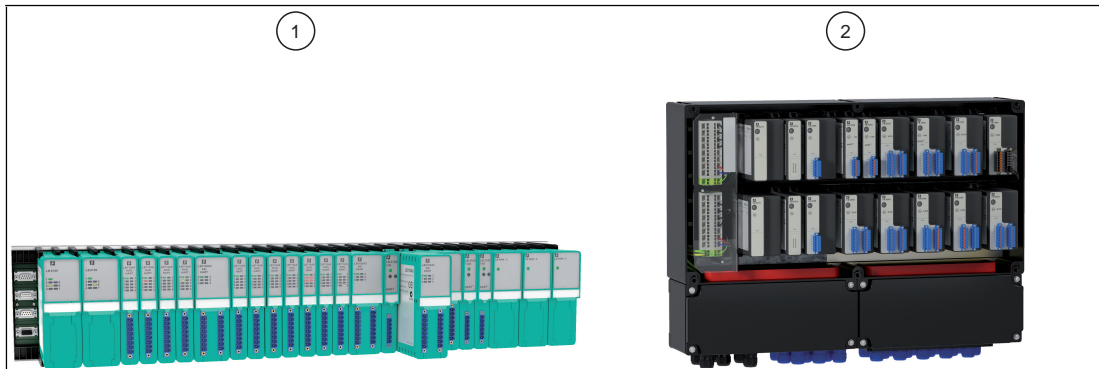

Figure 2.1 Example of LB/FB remote I/O stations

- 1 LB remote I/O station for use in the safe area and Zone 2
- 2 FB remote I/O station for use in Zone 1

Configuration Tasks

The parameterization of the I/O modules is stored in the nonvolatile com unit memory. When an I/O module is replaced, the new module automatically adopts the configuration of the previous module, provided the same type of module is used.

Diagnostics

Diagnostics information is reported to the process control system via the bus. Moreover, queries can be submitted via an independent service bus. However, the service bus is not absolutely essential for obtaining a fully operational system.

Interfering signals are mostly filtered out. However, a state-of-the-art screening concept should still be applied. Some I/O modules have adjustable filter functions.

Redundancy

A redundant bus connection is possible if the bus system allows.

Output Shutdown

The output shutdown enables bus-independent shutting down of all or selected I/O modules within the Remote I/O system. This feature requires the use of appropriately equipped backplanes and I/O modules with shutdown input.

3 Maximum Number of Channels and I/O Modules

The maximum number of channels depends on the I/O modules used, as the I/O modules have a different number of channels depending on the module type and width.

The maximum number of I/O modules per remote I/O station is determined by the following factors.

1. Slots on the backplane and width of the I/O modules
2. Size of the com unit memory for input and output data
3. Length of DP configuration string
4. Power supplies on the backplane

In addition to the factors mentioned above, the sum of all parameter data of the I/O modules (e.g., line fault detection on/off) must not exceed a length of 232 octets. However, this length limitation is exceeded in only a few cases, and compliance is usually checked by the configuration tool of the master. Information on the parameter data of the individual I/O modules can be found in the GSD/GSE file.



Tip

Use an FDT frame application, such as PACTware™ and the device type manager (DTM) for LB/FB to test different configurations of the remote I/O station.

The DTM automatically verifies the following aspects:

- the number of slots on the backplane
- module types supported by the com unit firmware
- the size of the com unit memory for input and output data
- compliance with the maximum length of the DP configuration string
- sufficient power for all modules

Slots on the Backplane and Width of the I/O Modules

Fixed slots are reserved on the backplane for com units and power supplies. The slots for I/O modules have equal status, meaning functions can be arranged side by side as required. Depending on how many single-width and double-width I/O modules you use, varying numbers of I/O modules can be accommodated on the backplane.

Size of the Com Unit Memory for Input and Output Data

Up to firmware version 6.28, the memory for input and output data is a total of 240 octets. With symmetrical distribution, 120 octets are available for input data and 120 octets for output data. An asymmetric distribution of 0 octets input data and 240 octets output data to 240 octets input data and 0 octets output data is likewise possible. The distribution is made in steps of 8 octets.

With firmware version 6.28 and higher, the memory for input and output data totals 480 octets. 240 octets are available for input data and 240 octets for output data. However, an asymmetric distribution is not possible.

Length of DP Configuration String

The DP configuration string contains the configuration code of the slots on a backplane and is limited to 96 octets. Ensure that the configuration code of the following I/O modules and com units is longer than that of the other I/O modules. See chapter 4.6

- LB4104, FB4204 output isolator
- LB4*05, FB4*05 HART output isolator
- LB4106 HART output isolator
- Com unit with global status/command register and module status

Empty slots located upstream of the last I/O module also have a configuration code. These empty slots must also be taken into account when considering the length of the DP configuration string.

Power Supplies on the Backplane

The amount of power available is dependent on several factors.

- Type of power supply
- Number of power supplies
- Power supply redundancy
- Environmental conditions, e.g., use in explosion-hazardous areas
- Com unit used
- Com unit redundancy

Example

The following example considers an LB remote I/O station.

- Base backplane LB9022
Provides slots for 2 com units, 3 power supplies, and 22 single-width I/O modules.
- Extension backplane LB9024
Provides slots for 3 power supplies and 24 single-width I/O modules. The com unit on the base backplane also controls the I/O modules on the expansion backplane.
- Power supply LB9006C
Provides a power of 25 W for operating the com unit and I/O modules in Zone 2 applications.
- Com unit LB8106*
Power consumption: 2 W

The DP configuration codes and the data volume of the I/O modules can be found in this manual. See chapter 6

The number of channels and the power consumption of the I/O modules can be found in the data sheets.

Maximum Number of Analog Channels

For an LB remote I/O station, the maximum number of analog channels results from the use of the following components: base backplane LB9022, expansion backplane LB9024, power supply LB9006C, com unit LB8106* from firmware version 6.28, 30 I/O modules LB7*04. With this combination, 120 analog channels can be operated in redundancy mode.

Maximum Number of Binary Channels

For an LB remote I/O station, the maximum number of binary channels results from the use of the following components: base backplane LB9022, expansion backplane LB9024, power supply LB9006C, com unit LB8106* from firmware version 6.28, 46 I/O modules LB1*09. With this combination, 368 binary channels can be operated in redundancy mode.

4 Configuring the Com Unit via the Class 1 Master

The configuration and parameterization of the com unit usually occurs exclusively via the PROFIBUS class 1 master. The PROFIBUS DP service `Set_Prm` is used for this. The com unit is parameterized via the PROFIBUS DP service `Set_Prm` for every restart. Changes to the com unit configuration thus result in a PROFIBUS restart, if the control system does not support Hot Configuration in Run (HCiR).



Caution!

Function interruption due to PROFIBUS restart

If you change the configuration of the com unit during ongoing operation and the control system does not support Hot Configuration in Run (HCiR), this will lead to a function interruption.

If possible, configure the com unit before the commissioning of the remote I/O station, to prevent a function interruption.

The integration into the PROFIBUS class 1 master occurs via a GSD/GSE file.

In addition to the GSD/GSE file, there are drivers available for further integration into various masters. The drivers provide the signals for the remote I/O station in processed format, meaning a manual integration of the I/O data in the data structures of the master is unnecessary. Drivers are available for Siemens systems. These integrate LB/FB remote I/O systems into the Siemens library, so that these can be managed as Siemens devices. ABB works with system templates that are simply used to enter different variables. The integration in Emerson DeltaV occurs via an import file that integrates LB/FB remote I/O systems into the DeltaV library, so that these are managed as Emerson devices.

The HART properties and diagnostic functions can be accessed via the control system, the service bus, or a secondary master.



Note!

If the class 1 master is not yet ready for operation, e.g., during partial commissioning, the remote I/O station can be configured with the help of the DTM and an external FDT framework application such as PACTware™. See chapter 5

4.1 Setting the PROFIBUS Address

Before PROFIBUS communication between the master and Remote I/O station is possible, the Remote I/O station must be assigned a unique PROFIBUS address. The PROFIBUS address of the Remote I/O station must be stored in the master.

You can assign the PROFIBUS address either with the help of a suitable master or with the help of the DTM. The PROFIBUS address can also be set via the service bus with the help of the DTM. See chapter 5



Note!

PROFIBUS Address Default Setting

The default PROFIBUS address of the com unit is set to 126 and the service bus address to 1. The PROFIBUS address 126 is a predefined address that is not available in PROFIBUS systems for operative slaves. When a new com unit is used, this predefined address prevents conflicts with the addresses of other slaves in the bus line.

4.2 Configuration via the Service Bus and PROFIBUS Class 2 Master

If the class 1 master is not yet ready for operation, e.g., during partial commissioning, the Remote I/O station can be configured with the help of the DTM and an external FDT framework application such as PACTware™. Communication between the DTM and the Remote I/O station can be established via a PROFIBUS class 2 master or the service bus. See chapter 5.1



Note!

Configuration via the DTM cannot be performed if the remote I/O station is in the `DataExchange` state. `DataExchange` state means that the PROFIBUS class 1 master has put the remote I/O station into operation and synchronous data exchange is taking place.

If the PROFIBUS class 1 master is in operation, the PROFIBUS class 2 master and the service bus can be used only for diagnostics, the presentation of parameters and process values, or HART communication.

For details about the configuration via the service bus with the help of the DTM, see chapter 5.

4.3 Configuration via PROFIBUS DP

4.3.1 Configuration with "Set_Prm"

After booting, the com unit receives **Set_Prm** data telegrams, which send the configuration parameters to the com unit. The parameters are stored in a buffer and only activated once **Check_Cfg** has been executed successfully. This ensures that the slots and I/O module types are assigned correctly. Data transfer between the master and slave can now begin.

If you are operating a master that has drivers or libraries, you do not need to worry about the byte strings. You only need to enter the relevant parameters.

The configuration string has 4 options and is structured as follows:

1. **DP_Config: 0x00**
com unit without additional data
2. **DP_Config: 0x31**
com unit with additional DP status and command area
3. **DP_Config: 0x15**
com unit with additional module status data
4. **DP_Config: 0XC0, 0x01, 0x07**
com unit with additional DP status and command areas and module status data

This string is always followed by 12 data bytes that define parameters related to the com unit. The following chapters explain these parameters in detail.

4.3.2 Setting the Parameters

The following parameters are defined in the GSD/GSE file. The parameters can be set using the configuration interface of the master.

Data_1

Bit	Function	Parameter	Selection
0 ... 1	Redundancy	P0_Channel	0 = none 1 = application redundancy 2 = line redundancy
2	PROFIBUS diagnostics	P0_Diag	0 = status and errors 1 = errors only
3	Suppressing PROFIBUS clear	P0_DpFlags	0 = off 1 = on
4 ... 5	–	–	–
6 ... 7	DP data	P0_DpFlags	0 = no DP data 1 = status/command register 2 = module status 3 = status/command register + module status

Redundancy

Select the redundancy type.

For more information about the configuration of a redundant com unit, see chapter 4.4.



Note!

Information on Redundancy

Further information about redundancy (basics, redundancy types, power supply redundancy) can be found in the hardware manual for LB or FB Remote I/O systems.

PROFIBUS diagnostics

This parameter affects the PROFIBUS standard diagnostics. If you select **Errors only**, you will receive a diagnostic message for device errors only. If you select **Status and errors**, you will also receive messages relating to changes in module status.

Suppressing PROFIBUS clear

Suppress clear stops null telegrams, which set all outputs to 0, from being executed. This is the prerequisite for a nondisruptive change to the configuration.

To use Hot Configuration in Run (HCiR), activate the **Suppress clear** option. Some systems can also use the **HCiR delay** or **Output OFF delay** parameters. See chapter 4.3.7

DP Data

The status and command registers contain module error information and transmit diagnostic information to the master. See chapter 4.7

The module status indicates which I/O module is not working correctly (1 bit per slot, 1 = module OK, 0 = module faulty).

4.3.3 Setting the Watchdog

Data_2

Bit	Function	Parameter	Selection
0 ... 3	Watchdog (output shutdown in the event of PROFIBUS failure)	P0_BusTo_1	0 = off 1 = 2 s 2 = 5 s 3 = 10 s 4 = 30 s 5 = 60 s 6 = 0.2 s 7 = 0.5 s 8 = 1 s
4 ... 7	–	–	–

Watchdog

After a bus communication failure, the watchdog activates the substitute value strategy stored for the I/O modules after a defined period of time. See chapter 6.2

If you do not want the I/O modules to accept substitute values after a bus communication failure, set this parameter to **0**. In this case, the output values remain frozen after a bus communication failure.

4.3.4 Scaling, Status Bits, and Cross-Talk Suppression

Normally, analog measured data is transferred in unsigned integers within a range between 10,000 (0 %) and 50,000 (100 %). For process control systems that are not capable of processing such wide number ranges, you can adjust the number range. The factory setting is 10,000 (0 % = 4 mA) up to 50,000 (100 % = 20 mA).



Note!

The scaling settings apply to all the analog inputs and outputs of a remote I/O station.

Data_3

Bit	Function	Parameter	Selection
0 ... 3	0 % ... 100 % scaling	Px_ScalMa,Me	0 = 10,000 ... 50,000 (0 ... 65,535) 1 = 0 ... 60,000 (0 ... 65,535) 2 = 5000 ... 25,000 (0 ... 32,767) 3 = 0 ... 30,000 (0 ... 32,767) 4 = 625 ... 3125 (0 ... 4095) 5 = 0 ... 4000 (0 ... 4095) 6 = 0 ... 27,648 (0 ... 32,767)
4	Globally activate status bit	Px_Scal option	0 = status bit for all I/O modules 1 = individual setting
5	Cross-talk suppression	Px option	0 = 50 Hz 1 = 60 Hz
6 ... 7	Setting the status bit individually	Px_Scale_Sel	0 = analog I/O modules without status bit 1 = analog outputs without status bit 2 = analog inputs without status bit

0 % ... 100 % Scaling

Please note that scaling is based on live zero signals (0 % = 4 mA, 100 % = 20 mA). When using the standard scaling of 10,000 (beginning of range) to 50,000 (end of range), 50 % is equal to the numerical value 30,000. If the value 0 is transferred by the bus, the output assumes the value 0 mA. Input signals of 0 mA are accordingly signaled to the process control system by the numerical value 0.

The same setting has different value ranges depending on the operating mode of the I/O module (live zero 4 mA ... 20 mA or dead zero 0 mA ... 20 mA).

Value Range for Live Zero and Dead Zero with Standard Scaling (10,000 ... 50,000)

	Live zero (4 mA ... 20 mA)	Dead zero (0 mA ... 20 mA)
0 mA	0	10,000
4 mA	10,000	18,000
20 mA	50,000	50,000



Example!

A process control system operates better within a range between 0 ... 4095 instead of 0 ... 65535. Select the following settings in the process control system to adapt the scaling.

- Start of range: 625
- End of range: 3125
- Scaling factor: 1.3107

Overranges and underranges of the 4 mA ... 20 mA signal can be displayed via the measured value.



Note!

If the status bits are activated when scaling from 0 to 4095 (equal to 12 bits), the resolution of the value decreases to 8 bits because the first 4 bits are used for status information.

With a 16 bit resolution of 10,000 ... 50,000, the intermediate steps in the first 4 bits are omitted accordingly.

Global Status Bits

This parameter allows you to show or hide the status information in the 4 bits of the lowest order from any analog data.

Cross-Talk Suppression

Cross-talk suppression can be adapted to the appropriate frequency to suppress cross-talk (50 Hz or 60 Hz).

Individual Status Bits

This parameter allows you to show or hide the status information in the 4 bits of the lowest order from specific analog data.

4.3.5 HART Parameters

You can activate or deactivate HART communication with the following com unit parameters for each slot.

You can use the **HART Active_Extension** parameter to activate or deactivate the automatic scanning of HART communication IDs, tags, and variables. All active HART channels are scanned automatically by default, such that HART data is retrieved and saved for quicker external access.

For more information on the subject of HART communication, see chapter 6.3.

Data_4

Bit	Function	Parameter	Selection
0	HART communication slot 01	px HartOption	0 = on 1 = off
1	HART communication slot 02	px HartOption	0 = on 1 = off
2	HART communication slot 03	px HartOption	0 = on 1 = off
3	HART communication slot 04	px HartOption	0 = on 1 = off
4	HART communication slot 05	px HartOption	0 = on 1 = off
5	HART communication slot 06	px HartOption	0 = on 1 = off
6	HART communication slot 07	px HartOption	0 = on 1 = off
7	HART communication slot 08	px HartOption	0 = on 1 = off

Accordingly, **data_5** acts for slots 09 ... 16, **data_6** for slots 17 ... 24, **data_7** for slots 25 ... 32, **data_8** for slots 33 ... 40 and **data_9** for slots 41 ... 48.

Data_10

Bit	Function	Parameter	Selection
0	HART Active_Extension	px HartOption	0 = HART active with scan ID, tag, variables 1 = HART active without internal scans
1 ... 7	–	–	–

4.3.6 Power Supply Monitoring

You can enable power supply monitoring for individual power supplies or all power supplies, or disable it for all power supplies. Note that the number of power supplies depends on the backplane used.

Power supply monitoring is disabled for all power supplies by default.

Data_11

Bit	Function	Parameter	Selection
0 ... 5	Power supply monitoring (LB-NT 1 ... 6 or FB-NT base, FB-NT red., FB-NT ext.)	P0_PowerOption	0x00 = monitor no power supplies 0x3F = monitor all power supplies 0xNN = monitor power supply NN
6 ... 7	–	–	–

Data_12

Bit	Function	Parameter	Selection
0 ... 7	–	–	–

4.3.7 Hot Configuration in Run (HCiR)

General parameters are defined in the GSD/GSE file in addition to the parameters for the com unit and the I/O modules. The general parameters are used to control the HCiR process.

However, the HCiR process of the EasyCom system is based on a process that does not require the general additional parameters. These parameters are of no importance for operating an EasyCom system, but are explained briefly in this section for reasons of completeness.

Hot Configuration in Run (HCiR) Function

The configuration of the master and slave in PROFIBUS systems must be the same at all times, otherwise data exchange will not be possible. As soon as the configuration of a remote-I/O station is changed, compliance of the configuration is no longer guaranteed. With HCiR, the difference in configuration between the master and slave is temporarily tolerated without disrupting the plant.

HCiR enables two configurations within the slave, regardless of the existence of a redundant system. If HciR is active, a new configuration can be transferred to the slave in the form of a passive data record. The master can access the slave using the old configuration until all the necessary modifications have been implemented in the master. The PROFIBUS restarts when the new configuration is activated in the master. When the new configuration in the slave matches the configuration in the master, the new configuration in the slave is activated automatically and the old configuration is deleted. However, if the PROFIBUS is started with a different configuration (e.g., because of a line failure or problems loading the master), the old configuration in the slave remains active.



Note!

In contrast, the EasyCom system implements the changes directly after they are transferred to the slave. When an HCiR change is made in the EasyCom system, the master must conclude all internal change operations, send new settings to the slave, and start exchanging data with the slave again immediately after the interruption of the data exchange. During the time when bus communication is interrupted, the master must ensure that input data is valid in conjunction with the controller.

Com unit parameters (HCiR)

Bit	Function	Parameters	Selection
0 ... 5	HCiR Delay		0 = 0 ms 1 = 100 ms 2 = 200 ms ... 63 = 6300 ms
6	–	–	–
7	HCiR Delay On/Off		0 = off 1 = on

HCiR Delay

The HCiR delay is designed for control systems that require time to restructure the data after a change to the com unit configuration. The outputs remain frozen during the HCiR delay to ensure a smooth changeover.

The adjustment range of 0 to 63 is multiplied by 100 ms to produce a delay time of between 0 and 6.3 seconds.

HCiR Delay On/Off

If you do not require the HCiR function, set the parameter to **Off**.

4.3.8 Preferred Parameter Values

The preferred parameter values are suitable for most systems. To minimize the number of error messages during initial commissioning, we recommend the temporary deactivation of the line fault detection.

Parameter	Default value
Local parameters (relate exclusively to the com unit)	
Redundancy	None
PROFIBUS diagnostics	Status and errors
Suppressing PROFIBUS clear	Off
DP data	Parameter is automatically set with the selection of the com unit from the device list
Watchdog	Off
Global parameters (relate to all of the I/O modules in the remote I/O station)	
0 % ... 100 % scaling	10,000 ... 50,000 (0 ... 65,535)
Globally activate status bit	Individual setting
Cross-talk suppression	50 Hz
Setting the status bit individually	Analog outputs without status bit
HART communication slot XX	On
HART Active_Extension	HART active with scan ID, tag, variables
Power supply monitoring	Monitor no power supplies

4.4 Setting Redundancy Com Units

In the event of **application redundancy**, the primary com unit does not exchange any setting information with the redundancy com unit.

With **line redundancy**, setting information is exchanged automatically as soon as the redundancy com unit is connected to the primary com unit and supplied with power.

PROFIBUS Addresses

You can assign the PROFIBUS address either with the help of a suitable master or with the help of the DTM.

In the event of application redundancy, the PROFIBUS address can be allocated individually. When there is line redundancy, the PROFIBUS addresses of the primary com unit and the redundancy com unit are identical, as the master addresses them both with the same data over separate bus lines.

Service Bus Addresses

The service bus address of the primary com unit is always modified using a separate tool. The service bus address of the redundancy com unit is allocated automatically if both com units are plugged in. The number 128 is added to the base address of the primary com unit.

Overall, $2 \times 119 = 238$ nodes are provided on the service bus. This requires a sufficient number of repeaters, as the RS485 bus standard only allows 31 nodes per repeater.

4.5 Advanced Diagnostics

The GSD/GSE file contains diagnostic information according to the PROFIBUS DP standard. The GSD/GSE file also contains information about extended device diagnostics, for which the diagnostics block requires an additional 12 bytes.

Each I/O module contains 2 bits of information. As a result, there are 12 bytes for 48 I/O modules. The information is transferred in the `Unit_Diag_Area` field, which begins with bit 48 for the I/O module in slot 1 and ends with bit 143 for the I/O module in slot 48. The module and data status are coded in 2 bits as follows.

Coding of Status Bits

Status	Function (xx = slot number)
00	Slot xx – data invalid
01	Slot xx – module fault
10	Slot xx – incorrect I/O module
11	Slot xx – missing I/O module

Extended PROFIBUS Diagnostics, Byte Arrays 1 ... 12

	Bit 7	Bit 6	Bit 5	Bit 4	Bit 3	Bit 2	Bit 1	Bit 0
Byte 1	Slot 04 Module status <code>Unit_Diag_Area</code> 54 ... 55		Slot 03 Module status <code>Unit_Diag_Area</code> 52 ... 53		Slot 02 Module status <code>Unit_Diag_Area</code> 50 ... 51		Slot 01 Module status <code>Unit_Diag_Area</code> 48 ... 49	
Byte 2	Slot 08 Module status <code>Unit_Diag_Area</code> 62 ... 63		Slot 07 Module status <code>Unit_Diag_Area</code> 60 ... 61		Slot 06 Module status <code>Unit_Diag_Area</code> 58 ... 59		Slot 05 Module status <code>Unit_Diag_Area</code> 56 ... 57	
Byte 3 ... 11	
Byte 12	Slot 48 Module status <code>Unit_Diag_Area</code> 142 ... 143		Slot 47 Module status <code>Unit_Diag_Area</code> 140 ... 141		Slot 46 Module status <code>Unit_Diag_Area</code> 138 ... 139		Slot 45 Module status <code>Unit_Diag_Area</code> 136 ... 137	

4.6 Meaning of the DP Configuration String

Process control systems that support the FDT concept use the operator interface of the DTM as a component of their own systems. Other process control systems have either a separate driver, e.g., Siemens SIMATIC PDM, or they use a text-based GSD/GSE file. In these cases, observe the operating instructions from the relevant manufacturer.

The following notes provide information about PROFIBUS communication and are particularly useful when using the GSD/GSE file.



Note!

If you are operating a master that supports the FDT concept or has drivers or libraries, you do not need to worry about the subsequent byte strings because the master adopts the details automatically.

The sequence of PROFIBUS data words can be found in the DP configuration string (1 data word = 16 bits). The sequence corresponds to the arrangement of the I/O modules on the backplane, where the input and output bytes of the I/O modules are sorted into input and output blocks. → see Figure 4.1 on page 28

The DP configuration string is a direct representation of the arrangement and configuration of the I/O module on the relevant backplane. Each I/O module has a DP configuration code. For example, the LB1*08 and FB1*08 digital input has the DP configuration code 11. The DP configuration string consists of the individual DP configuration codes.

It is essential for successful PROFIBUS communication that the DP configuration string in the master and in the remote I/O station are identical.

The table (see table "Data Structure on the PROFIBUS" on page 28) is a simplified version of the same module arrangement shown in the illustration (→ see Figure 4.1 on page 28) and represents the relationship between the data structure of the DP configuration string and the input and output bytes of the I/O modules.

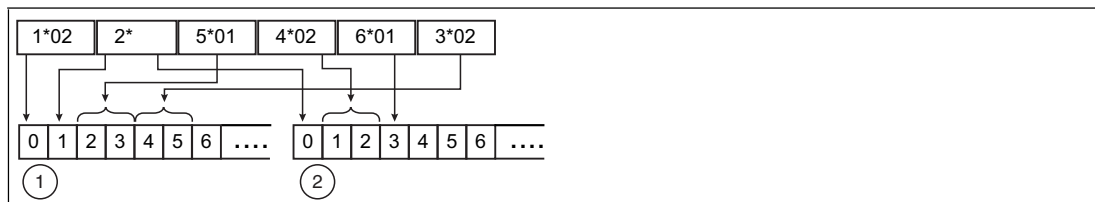

Figure 4.1 Effect of the module arrangement on the data structure

- 1 Input bytes
- 2 Output bytes

Data Structure on the PROFIBUS

Module arrangement						
Slot no.	1	2	3	4	5	6
I/O module	LB1*02, FB1*02	LB2002, LB21*, FB22*	LB5*01, FB5201	LB4*02, FB4*02	LB6101, FB6301	LB3*02, FB3*02
DP config. string	10	30	50	60	20	50
Data	1 byte ON	1 byte ON 1 byte OFF	1 word ON	1 word OFF	1 byte OFF	1 word ON
Byte ON	1	1	2			2
Byte OFF		1		2	1	

200337 2016-03

Input bytes						
Byte no.	0	1	2	3	4	5
I/O module (slot)	LB1*02, FB1*02 (1)	LB2002, LB21*, FB22* (2)	LB5*01, FB5201 (3)		LB3*02, FB3*02 (6)	
Output bytes						
Byte no.	0	1	2	3	4	5
I/O module (slot)	LB2002, LB21*, FB22* (2)	LB4*02, FB4*02 (4)		LB6101, FB6301 (5)	Empty	Empty

Initially, all output data is transferred to the slave as specified in the PROFIBUS standard (DataExchangeRequest). Then all input data is transferred to the process control system as a response (DataExchangeResponse). Refer to the following table for the individual hexadecimal values that make up the DP configuration string. The table contains the meaning and the input and output bytes of each hexadecimal value.

For more information about the data structure and bit structure within the input and output bytes for the individual I/O modules, see chapter 6.



Note!

Special feature of I/O modules LB1*03, FB1*03 and LB3*02, FB3*02

Depending on the function type, the LB1*03, FB1*03 frequency/counter input is 2, 4, or 6 bytes in length and the DP configuration code is 50, 51, or 52.

Depending on the number of HART auxiliary variables, the length of the HART transmitter power supply LB3*02, FB3*02 current input is 2, 6, 10, 14, or 18 bytes and the DP configuration code is 50, 52, 54, 56, or 58.

DP Configuration Codes

DP config. code (hexadecimal)	DP config. code (decimal) ¹	Length	Meaning
00	0		Empty slot or com unit without data
10	16	1 octet ON	LB1*01, FB1*01, LB1*02, FB1*02 digital input
11	17	2 octet ON	LB1007, LB1*08, FB1*08, LB1*09, FB1*09, LB1014, LB1015 digital input
15	21	6 octet ON	LB8*0*, FB8*0* com unit with module status
20	32	1 octet OFF	LB6101, FB6301 relay contact output
30	48	1 octet ON 1 octet OFF	LB2002, LB21*, FB22* digital output with position feedback LB6005, FB6305 relay contact output LB6*1*, FB621* digital output
31	49	2 octet ON 2 octet OFF	LB8*0*, FB8*0* com unit with global status/command register LB6006, FB6306 relay contact output LB6*08, FB6*08 digital output
50	80	1 word ON	LB1*03, FB1*03 frequency/counter input in frequency input or 12-bit counter input function type LB3101, FB3201 transmitter power supply, input isolator LB3*02, FB3*02, LB3103, FB3203 HART transmitter power supply, input isolator LB5*01, FB5201 RTD converter LB5*02, FB5202 thermocouple converter LB5*06, FB5206 voltage converter

DP config. code (hexadecimal)	DP config. code (decimal) ¹	Length	Meaning
51	81	2 words ON	LB1*03, FB1*03 frequency/counter input in 32-bit counter input function type
52	82	3 words ON	LB1*03, FB1*03 frequency/counter input in combined 32-bit counter and frequency input function type LB3*02, FB3*02 HART transmitter power supply, input isolator with 1 HART auxiliary variable
53	83	4 words ON	LB3104, FB3204 transmitter power supply, input isolator LB3*05, FB3*05 HART transmitter power supply, input isolator LB3*06 HART transmitter power supply LB5*04, FB5204 RTD converter LB5*05, FB5205 thermocouple converter
54	84	5 words ON	LB3*02, FB3*02 HART transmitter power supply, input isolator with 1st + 2nd HART auxiliary variables
56	86	7 words ON	LB3*02, FB3*02 HART transmitter power supply, input isolator with 1st to 3rd HART auxiliary variables
58	88	9 words ON	LB3*02, FB3*02 HART transmitter power supply, input isolator with 1st to 4th HART auxiliary variables
60	96	1 word OFF	LB4101, FB4*01 output isolator LB4*02, FB4*02 HART output isolator
73	115	4 words ON 4 words OFF	LB7*04, FB7*04 universal input/output (HART)
C0 01 07	192 1 7	8 octet ON 2 octet OFF	LB8*0*, FB8*0* com unit with global status/command register and module status
C0 43 40	192 67 64	1 word ON 4 words OFF	LB4104, FB4204 output isolator LB4*05, FB4*05 HART output isolator LB4106 HART output isolator
¹ Under certain circumstances, some older process control systems require decimal figures instead of hexadecimal figures for parameterization.			

In the DP configuration string, the first configuration code is always assigned to the com unit. Redundant com units are implicitly included in the bus connection configuration code and are not listed separately. Depending on the configuration, the com unit can have four different DP identifiers.

The global status register occupies 2 input bytes. The 6 input bytes for the module status (1 bit per I/O module) follow the input bytes of the global status register. The module status bit adopts the status 1 if the associated I/O module is active and free of faults. Otherwise, the status is 0.

The DP configuration codes for the individual I/O modules only follow the com unit with the global status/command register and the module status (). See table "Sequence of the DP configuration code in the DP configuration string" on page 31

Sequence of the DP configuration code in the DP configuration string

Slot	Device	Description	DP config. code
0	Com unit (with one of the configurations on the right)	Without data	00
		With status/command register	31
		With module status	15
		With status/command register and module status	C0 01 07
1	I/O module	Type-dependent	Type-dependent
n	I/O module	Type-dependent	Type-dependent

4.7 Structure of the Global Status Register

The global status register comprises 2 input bytes located at the start of the DP configuration string. See chapter 4.6

The description of the individual bits is shown in the table below.

In PROFIBUS DP V1 systems, standard DP diagnostics are automatically made available. These features are not described in detail here, since they depend on the respective options provided by the master.

Structure of the Global Status Register

Byte	Bit/state	Meaning	
2	15	= 0	Com unit is passive
		= 1	Com unit is active
	14	= 0	Operating mode: no simulation
		= 1	Operating mode: a minimum of one I/O module is simulated.
	13	= 0	No fault
		= 1	Fault
	12	= 0	General fault
		= 1	Module fault
	11		The error code consists of bits 11 to 8, e.g., 0 1 1 1, produces an error code of 7 (hexadecimal) = power supply fault. The meaning of all error codes is shown in the table below.
	10		
	9		
	8		
1	7	= 0	1 fault
		= 1	Multiple faults
	6	= 0	No parameterization/processing
		= 1	Parameterization/processing in progress
	5		Bits 5 ... 0: <ul style="list-style-type: none"> ■ If a single error occurs (bit 7 = 0), the faulty slot can be determined with reference to these bits, e.g., 0 0 0 1 0 0 indicates slot 4 (hexadecimal). ■ If multiple errors occur (bit 7 = 1), the number of errors can be determined. ■ If only power supply faults occur (bit 11... 8 = 7, bit 7 = 0), one bit is assigned to each power supply (power supply 1 = bit 0, ..., power supply 6 = bit 5), whereby the status 1 represents a fault.
	4		
	3		
	2		
	1		
	0		

Error code of the global status register

Error code (hex)	Clear text message
0	No error
1	Memory error PIC (RAM)
2	Memory error PIC (register)
3	Memory error PIC (flash)
4	PIC internal error
5	Command error PIC
6	Module fault
7	Power supply fault
8	Memory error CPU32 (RAM)
9	Memory error CPU32 (flash)
A	CPU32 internal error (watchdog)
B	Redundancy error, arithmetic
C	Redundancy error, partner not present (no redundancy Com Unit)
D	Redundancy error, link
E	Redundancy error, parameter inconsistent
F	Reserved

4.7.1 Example of Global Status Register

In the following example, the global status register contains the character string A784.

The raw data value is produced from the 16 bits in the status register. The table below outlines how the raw data value A784 is compiled and on which status displays the value appears.

Example of Global Status Register Using the Raw Data Value "A784"

A784	Bit/state		Description
A	15	= 1	The com unit is active.
	14	= 0	No simulation.
	13	= 1	Error.
	12	= 0	General fault
7	11	= 0	Bits 11 ... 8 with states 0 1 1 1 produce the error code 7. The error with the highest priority is a power supply fault.
	10	= 1	
	9	= 1	
	8	= 1	
8	7	= 1	Multiple error.
	6	= 0	No parameterization/processing
	5	= 0	There are 4 errors active (multiple errors). Bits 5 ... 0 with the states 0 0 0 1 0 0 produce the number 4.
	4	= 0	
4	3	= 0	
	2	= 1	
	1	= 0	
	0	= 0	

4.8 Command Register

The command register comprises two bytes. The first byte is the parameter byte, the second the command byte. These bytes can be used to transfer commands from the master to the remote I/O station via the bus.

The command they contain is executed only if the command register has changed. Therefore, a command is only executed once, namely, when the changed command register has been transferred to the com unit for the first time.

The command register can be transferred together with the global status register as part of the cyclic com unit data. The global status register occupies the first two bytes in the response telegram (`DataExchangeResponse` from the remote I/O station to the master). The command register occupies the first two bytes in the request telegram (`DataExchangeRequest` from the master to the remote I/O station).

The following commands are supported.

Parameter (byte 1)	Command (byte 2)	Meaning
0x00	0x08	Clear all 32 bit counters.
0xnn	0x08	Clear 32 bit counter of slot nn.
0x00	0xF8	Cold start
0x00	0xF9	Warm restart
0x00	0xF5	Become passive (command to active com unit). Since the two com units of a redundant system cannot both be passive, the partner com unit becomes active because of this command. The command is meaningless if sent to the passive com unit.
0x00	0xF6	Become active (command to passive com unit). Since the two com units of a redundant system cannot both be active, the partner com unit becomes passive because of this command. The command is meaningless if sent to the active com unit.
0x00	0xF7	Redundancy switchover This command generates a redundancy switchover, whichever com unit it is sent to. Therefore, it is not essential to know which com unit is currently active/passive.

4.9 Electrical Testing of Connections

Make sure that the terminators have been properly fitted to the fieldbus and service bus.



Test of Physical Connection Right to the End of the Segment



Tip

Perform the measurements from the control room.

1. Disconnect the bus connector from the master.
2. Deactivate the terminator on the bus connector (bus start).
3. Measure the voltage at the bus connector between A and B.

↳ A voltage of $U = 220 \Omega / (220 \Omega + 2 * 390 \Omega) * 5 \text{ V} = 1.1 \text{ V}$ must be present between A and B. This voltage comes from the field-side terminator.

If the 1.1 V voltage is not present, there is either no terminator connected at the end, the cable is faulty, or there is no terminating voltage at the remote I/O station.

4. Measure the current at the bus connector between A and B.

↳ It must be possible to measure a current of $I = 5 \text{ V} / (2 * 390 \text{ } \Omega) \approx 6.4 \text{ mA}$ between A and B.

If the current is significantly higher, by a factor of 2 or more, the bus is terminated using more than one terminator.

If the current is $I \approx 0 \text{ mA}$, then either there is no terminator present, the cable is faulty, or there is no terminating voltage. In this case, a resistance of $220 \text{ } \Omega$ should be measured between A and B.

If no current or resistance can be measured, the terminator at the end of the bus is missing or the cable is faulty.

5. Activate the terminator on the bus connector for the master.
6. Plug the bus connector back into the master.

Test of Physical Remote I/O Station Connection



Danger!

Risk of explosion

When taking measurements in hazardous areas, there is a risk of explosion from sparks forming.

Take measurements on the terminal connections of a remote I/O station, with a hot work permit only, in other words when there is no potentially explosive atmosphere.

1. Disconnect the bus connector from the master.
2. Deactivate the terminator on the bus connector (bus start).
3. Measure the voltage between A and B on the bus connection of each remote I/O station.
 - ↳ A voltage of $U = 1.1 \text{ V}$ must be present between A and B on each remote I/O station.
4. Activate the terminator on the bus connector for the master.
5. Plug the bus connector back into the master.



Note!

Please refer to the current literature for more information.

4.10 Commissioning of the Remote I/O Station

Do not start to operate all the slaves simultaneously, but connect each slave to the master in succession. For fault analysis, we recommend using a standard bus monitor that is capable of passively monitoring bus telegrams.

If the class 1 master does not support the `Set Slave Address` service, the address can be set via the service bus. See chapter 4.1

The I/O modules are addressed automatically relative to the station address.

LEDs on the front of the com unit indicate active data communication:

- If a yellow LED does not flash on the com unit when a slave is accessed, there is an interruption in the transmitting cable to the master, which can indicate an interface fault in the master or a cable fault.
- If communication cannot be established, the wrong station address may have been selected. Alternatively, the terminator may not be connected, or spurs may have been laid that are not permitted.

When installing the bus, make sure that the transmitting and receiving lines RTD-P and RTD-N have not been swapped. Swapping these lines may block access to one slave but allow access to all the others. If the lines are swapped when looping through to the terminals on the slave, access to all other subsequent stations is blocked.

Make sure that the parameterization of the master and slave corresponds and that the PROFIBUS ID number is correct.

Configure the Remote I/O station using your master configuration software and the GSD file.

In addition, note the following points to successfully commission the bus.

- There must be a terminator at the beginning and end of the bus. Corresponding Sub-D bus connectors with connectable terminator are available under product names LB9001A ... LB9003A.
- The master read cycle and the com unit watchdog must be adapted to one another. This is usually a standard function for the process control system.
- Remember that some process control systems can only process limited data records. Older Siemens Teleperm systems, for example, are able to process only 32 bytes of input and output data per slave. The accuracy of analog circuits requires the transfer of 2 bytes per channel. In this case, 16 analog inputs only can be used in the Remote I/O station.

More information about Remote I/O hardware can be found in the LB/FB hardware manual.

4.11 Replacing or Adding Com Units



Danger!

Risk of explosion

When work is performed on the remote I/O unit in hazardous areas, there is a risk of explosion from spark formation.

Before starting any work on the remote I/O unit, familiarize yourself with the instruction manuals for the components and their relevant certificates.



Note!

PROFIBUS Address Default Setting

The default PROFIBUS address of the com unit is set to 126 and the service bus address to 1. The PROFIBUS address 126 is a predefined address that is not available in PROFIBUS systems for operative slaves. When a new com unit is used, this predefined address prevents conflicts with the addresses of other slaves in the bus line.



Caution!

Bus conflicts

Incorrect PROFIBUS addresses can lead to bus conflicts.

Make sure that the PROFIBUS address of the new com unit is the same as the com unit being replaced.

In a redundant system, com units should be replaced while the plant is operating only if the com units have **line redundancy** and the PROFIBUS address in the com unit is preset to 126.



Replacing Com Units (1:1 Replacement)

1. Make sure that the firmware version of the new com unit is the same as the com unit being replaced.
2. Make sure that the PROFIBUS address of the new com unit is the same as the com unit being replaced. Use a separate remote I/O configuration slot to perform checks and configure the correct PROFIBUS address in the com unit.
3. Replace the old com unit with the new one.



Adding Redundant Com Units



Note!

A redundant com unit automatically adopts the parameters of the primary com unit via an internal connection. In FB remote I/O stations, the internal connection between the two com units is established via the front cable connection before the redundant com unit is installed. In LB remote I/O stations, the internal connection is established automatically via the backplane.

1. Make sure that the redundant com unit does not occupy a PROFIBUS address that is already used by another slave in the system. The default PROFIBUS address setting 126 is suitable here because another slave cannot occupy this address.
2. Add the redundant com unit.

5 Configuring the Com Unit via the Device Type Manager (DTM)

The configuration and parameterization of the com unit usually occurs exclusively via the PROFIBUS class 1 master. See chapter 4

If the class 1 master is not yet ready for operation, e.g., during partial commissioning, the Remote I/O station can be configured with the help of the DTM and an external FDT framework application such as PACTware™. Note that the DTM cannot only be used with PACTware™, but also with other FDT-based applications.

You can download the DTM from the **Software** area on the www.pepperl-fuchs.com website.

Communication between the DTM and the Remote I/O station can be established via a PROFIBUS class 2 master or the service bus. See chapter 5.1



Note!

Configuration via the DTM cannot be performed if the remote I/O station is in the `DataExchange` state. `DataExchange` state means that the PROFIBUS class 1 master has put the remote I/O station into operation and synchronous data exchange is taking place.

If the PROFIBUS class 1 master is in operation, the PROFIBUS class 2 master and the service bus can be used only for diagnostics, the presentation of parameters and process values, or HART communication.

As soon as the Remote I/O station is in the `DataExchange` state, write access is rejected by the DTM and the Remote I/O station is configured by the PROFIBUS class 1 master. Parameter values set by the DTM will be overwritten by the PROFIBUS class 1 master. Parameter values that are not or only partially set by the PROFIBUS class 1 master are overwritten with default values.

5.1 Communication with Remote I/O Station

Communication between the DTM software and the Remote I/O station can be established via the PROFIBUS or the service bus. The configuration can be achieved via the PROFIBUS or in DTM version 7.3 and higher as well as via the service bus. Configuration of the Remote I/O station works in almost the same way for both types of connection.

Components Required for a PROFIBUS Connection

- FDT base application, e.g., PACTware™
- DTM LB/FB
- PROFIBUS communication DTM
- PROFIBUS class 2 master + cable harness, e.g., Softing PROFlusb

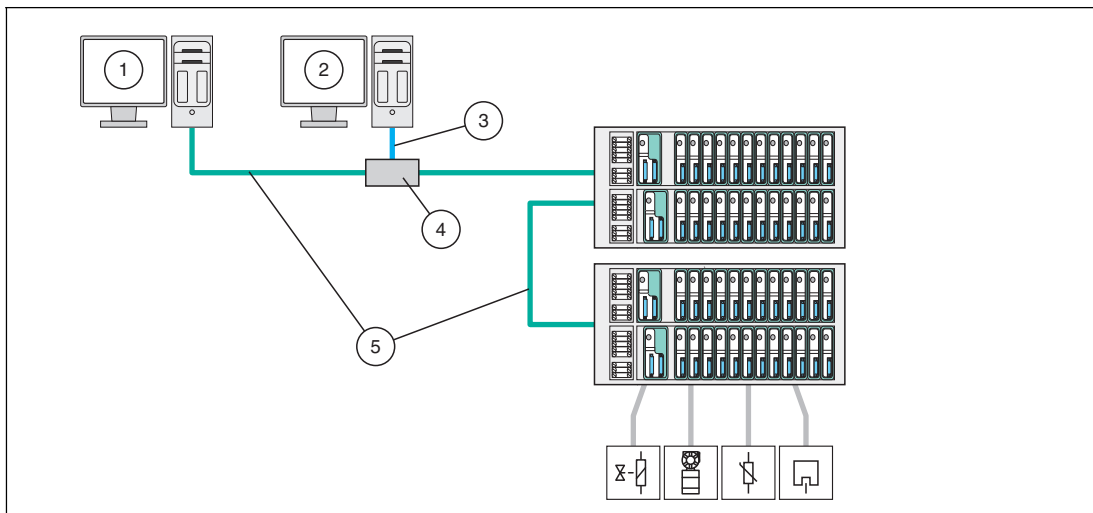

Figure 5.1 PROFIBUS Connection on the Remote I/O Station

- 1 Master/Engineering station for the configuration and parameterization of the Remote I/O station via GSD/GSE file
- 2 PC with FDT 1.2 framework application and DTM LB/FB for diagnostics and HART communication
- 3 Connection from the PC to the PROFIBUS class 2 master e.g., via Ethernet or USB
- 4 PROFIBUS class 2 master
- 5 PROFIBUS

Components Required for a Service Bus Connection

- FDT base application, e.g., PACTware™
- DTM LB/FB
- Interface converter (RS232 to RS485 converter or USB to RS485 converter) such as W&T RS232 to RS485 or ICP Con I-7561 USB to RS485
- Compatible cable harness

The communication DTM for the service bus is contained in the DTM LB/FB.

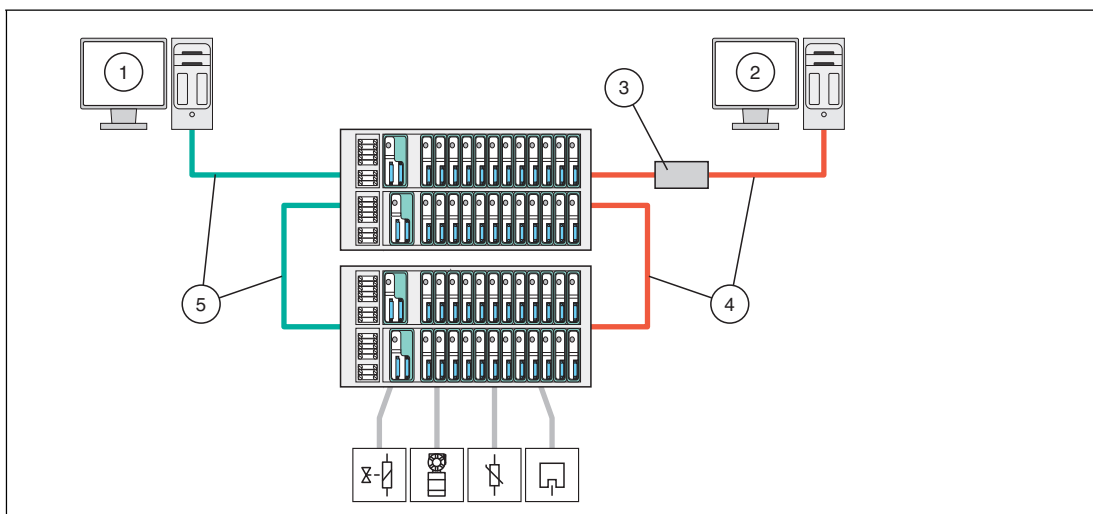

Figure 5.2 Service bus connection on the Remote I/O station

- 1 Master/Engineering station for the configuration and parameterization of the Remote I/O station via GSD/GSE file
- 2 PC with FDT 1.2 framework application and DTM LB/FB for diagnostics and HART communication
- 3 Interface converter
- 4 Service bus
- 5 PROFIBUS

5.1.1 Service Bus Connection via RS-232



Danger!

Risk of explosion

When work is performed on the remote I/O unit in hazardous areas, there is a risk of explosion from spark formation.

Work must be performed with a hot work permit only, in other words when there is no potentially explosive atmosphere.

The W&T RS-232-RS-485 interface converter can be connected to the remote I/O unit using either a preassembled or self-made cable. You can order the preassembled cable together with the W&T RS-232-RS-485 interface converter from Pepperl+Fuchs.

Use the following wiring diagram if you intend to make your own cable.

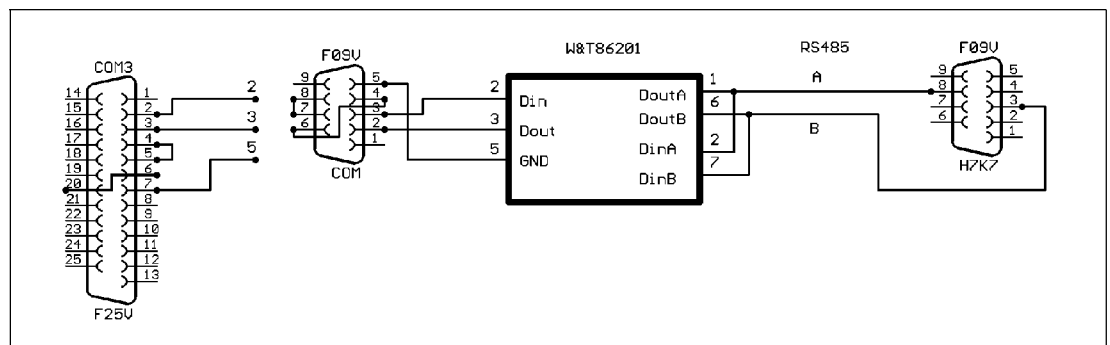

Figure 5.3 Wiring diagram for W&T RS-232-RS-485 interface converter

5.1.2 Service Bus Connection via USB



Connecting the USB Converter to the PC

1. Install the driver that accompanies the USB-RS-485 converter.
2. Connect the USB converter to any USB port on the PC.

↳ The hardware wizard automatically detects and installs a new USB device. The converter is listed under connections in the hardware manager COM port list. The COM port to which the converter was assigned can be seen in this list. The COM port in use can be modified via the same entry in the device manager if required (**Properties** context menu).

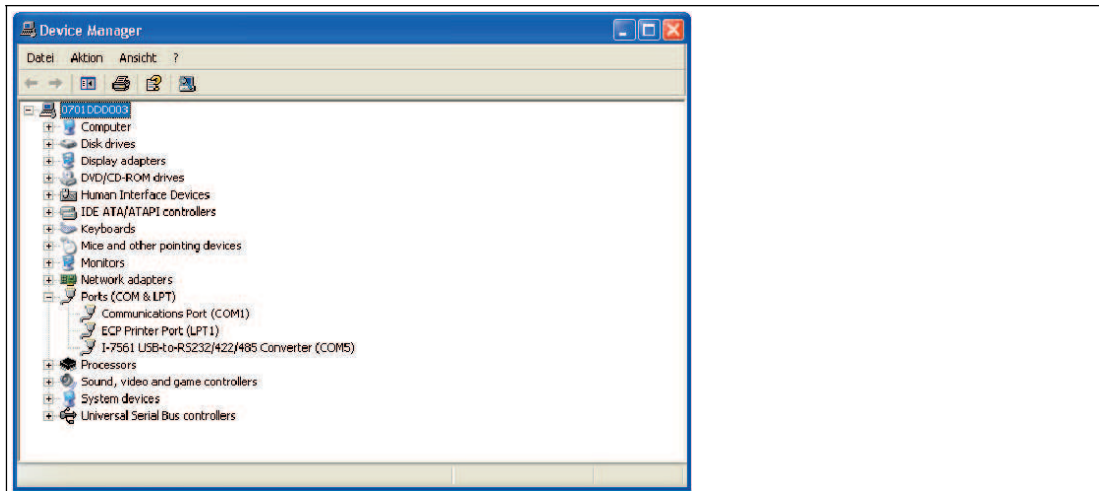

Figure 5.4 USB converter in device manager

5.2 Creating a New Project



Creating a new project in PACTware™?

Select **File > New** or click  **Create New Project**.

↳ A new, unnamed project appears in the main window. The project initially consists of the entry **HOST PC**.

5.3 Integrating the Service Bus Communication DTM

If you wish to establish a connection via the service bus, integrate the service bus communication DTM into the project as follows.

The service bus communication DTM is contained in the DTM LB/FB. The service bus communication DTM must be added to the project structure before all other DTMs.



Adding Communication DTMs

1. Select the entry **Host PC** in the project view.
2. Select **Device Data > Add Device** or click on the **Add Device** icon on the toolbar.



↳ A device selection window opens.

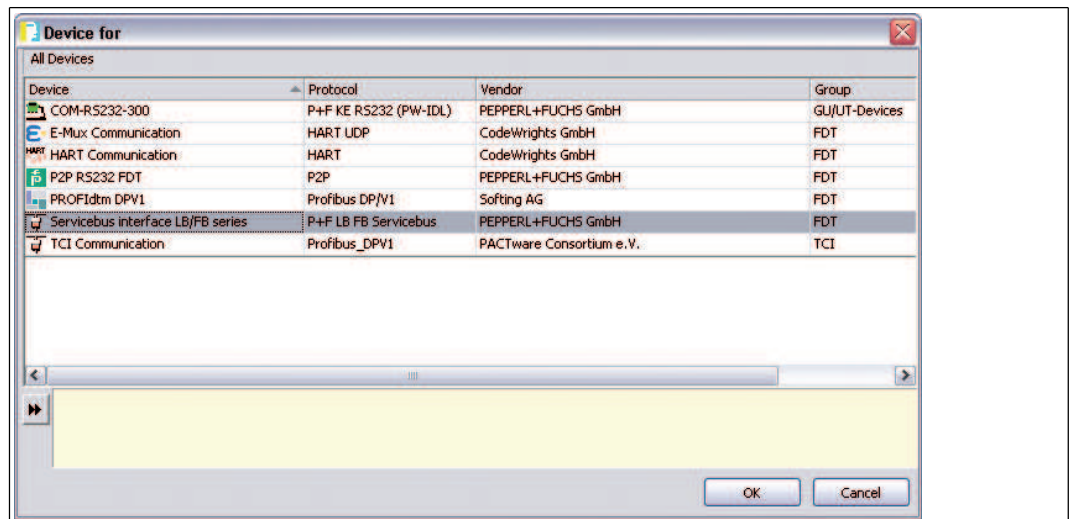

Figure 5.5 Selecting the communication DTM

3. Select the entry **Service bus interface LB/FB series**.
4. Click on **OK**.
 - ↳ The service bus communication DTM is added and appears in the project structure.
5. As service bus communication is handled by a COM port on the computer, the service bus communication DTM must be allocated a COM port. Right-click on the **LB/FB service bus** entry in the project structure.
6. In the context menu select **Parameter > Parameterization > Set COM Port**.

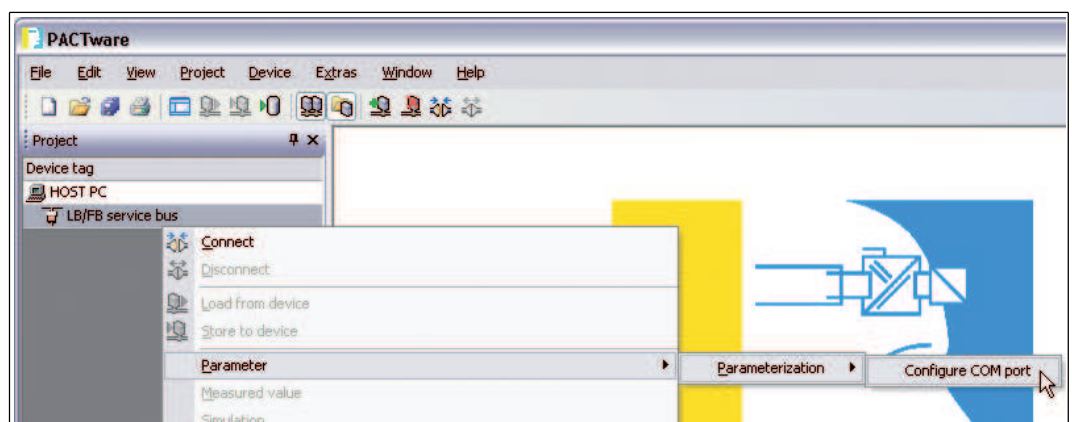

Figure 5.6 Setting the COM port

- ↳ The device data window containing the COM port settings opens.
7. Set the COM port.



Figure 5.7 Setting the COM port

8. Click on **OK**

5.4 Integrating the PROFIBUS Communication DTM

If you wish to establish a connection via the PROFIBUS, integrate the PROFIBUS communication DTM into the project as follows. The following example uses PROFIdtm from Softing.

Adding Communication DTMs

Before you can integrate the PROFIBUS communication DTM into the project, the PROFIBUS communication DTM must be installed on the computer.

1. Select the **Host PC** entry in the project view.
2. Select **Device Data > Add Device** or click on the **Add Device** icon on the toolbar.



↳ A device selection window opens.

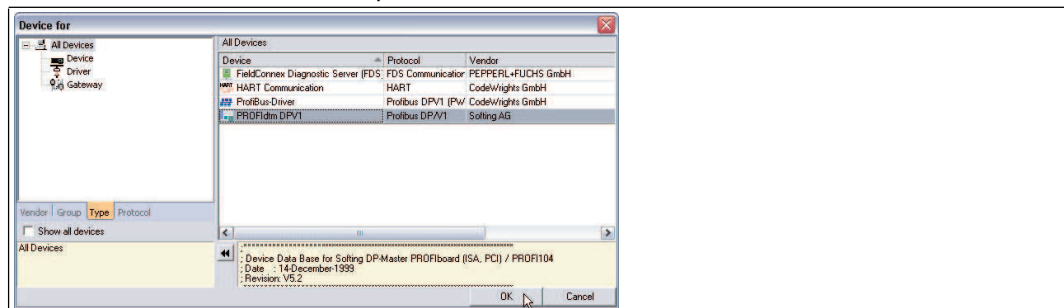

Figure 5.8 Selecting the communication DTM

3. Highlight the PROFIBUS communication DTM, in this example **PROFIdtm DPV1**.
4. Click on **OK**.

↳ The PROFIBUS communication DTM is added and appears in the project structure.



Caution!

Conflicts in the PROFIBUS system

In the case of parallel coupling within existing PROFIBUS systems, integrate the PROFIBUS master card as a class 2 master. Use the correct baud rate and make sure there are no address conflicts.

Numerous adjustments can be made on the PROFIBUS communication DTM. For a precise description of the adjustment options, refer to the instructions from the relevant manufacturer.

To modify the PROFIBUS settings in PACTware™, proceed as follows.



Modifying PROFIBUS Settings

1. Right-click on the PROFIBUS communication DTM in the project structure, in this example on **PROFIdtm DPV1**.
2. Select **Parameterize**.

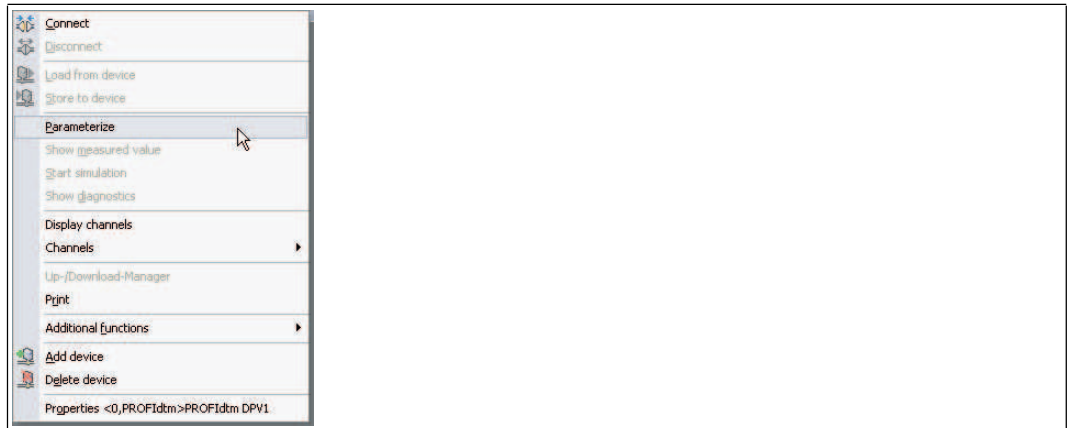

Figure 5.9 Parameterizing PROFIBUS Communication DTM

↳ The device data window containing the bus parameters opens.

3. Edit the relevant parameters.
4. To edit other parameters, right-click again on the **PROFIdtm DPV1** entry in the project structure.
5. Select **Additional functions**.
6. Here you can change DTM station addresses, open the PROFIBUS control panel, or access the online help.

5.5

Adding Com Units

There are two options available for integrating com units into the PACTware™ project.

- Integrate com units via the **Add Device** command
- Generating com units automatically



Adding Com Units via the "Add Device" Command

Before you can integrate a com unit into the PACTware™ project, DTM LB/FB must be installed on the computer and a communication DTM must be integrated into the project structure.

1. Select the entry for the previously integrated communication DTM in the project view.
2. Select **Device Data > Add Device** or click on the **Add Device** icon on the toolbar.



↳ A window opens displaying a list of available com units.

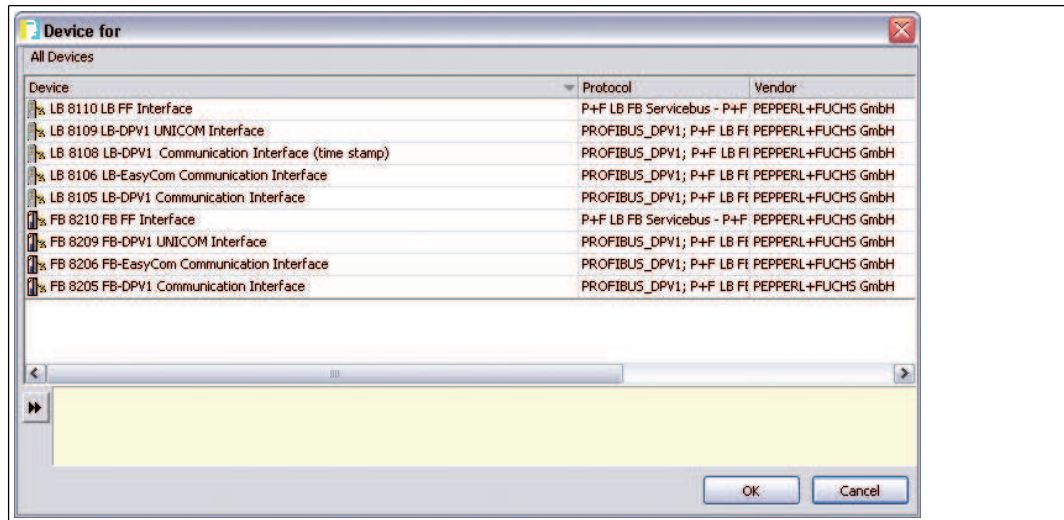

Figure 5.10 Selecting the Com Unit

3. Select the com unit installed in your Remote I/O station.
4. Click on the **OK** button.

↳ The com unit is added and appears under the communication DTM in the project structure.

In the right half of the program window, a device data window appears with a prompt asking you to enter the address of the Remote I/O station.

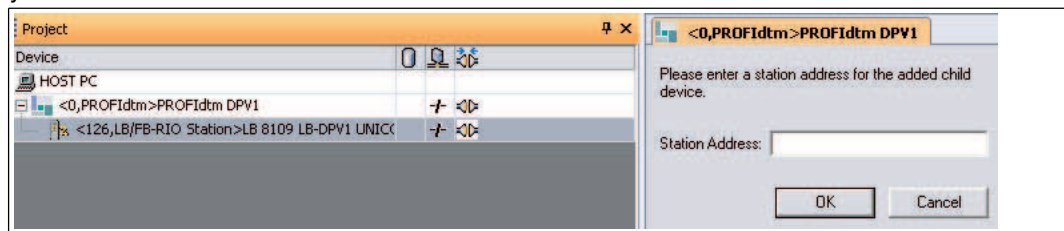

Figure 5.11 Entering the station address

5. Enter the station address.
6. Click on the **OK** button.

↳ The com unit has now been added to the project and can be parameterized. If the Remote I/O station contains multiple com units, repeat the steps for each com unit.

Generating Com Units Automatically

Note!

The com unit can only be generated automatically via a **service bus connection**.

Before allowing the com unit to be generated automatically, there must be a physical connection with the Remote I/O station via the service bus, and the service bus communication DTM must have been added to the project structure.

1. Right-click on the **LB/FB service bus** entry in the project structure.
2. Establish a connection to the Remote I/O station. Select **Connect** from the context menu.

↳ The communication DTM entry appears bold in the project structure as soon as the connection is established.

3. Right-click on the **LB/FB service bus** entry in the project structure.

4. Select **Additional functions > Scan Service Bus**.

↳ The **Scan Service Bus** window appears.

5. Enter the address range that you wish to scan in the **Scan Range** fields.

6. Click on **Start Scan**.

↳ A progress bar indicates the current status of the scanning process. When the scanning process finishes, all located com units are listed in a table.

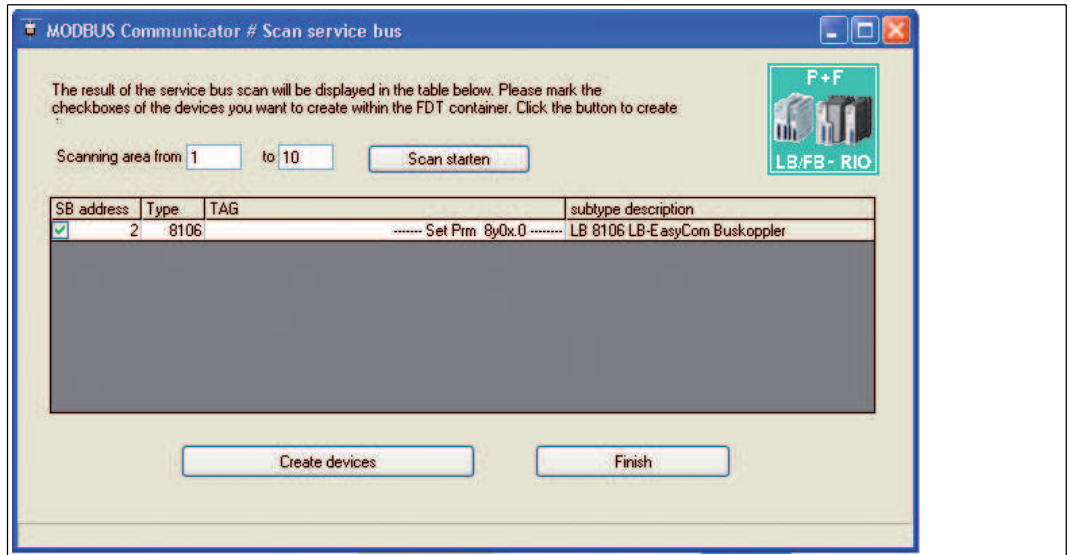

Figure 5.12 Service bus scan results

7. Select one or more com units by activating the relevant check boxes in the **SB Address** column.

8. If you would like to change the service bus address of a com unit, double-click on the relevant line from the list in the table.

↳ The **Set Service Bus Address** window appears.

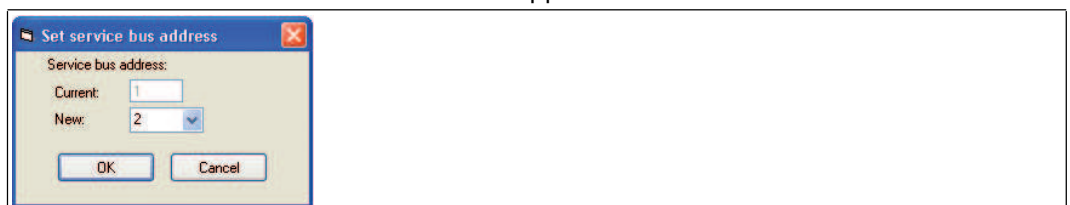

Figure 5.13 Setting the service bus address

9. Select the required service bus address from the **New** drop-down list and then click on **OK**.

↳ The service bus address has been changed.

10. Click on **Generate Devices** in the **Scan Service Bus** window to start configuring the generation process.

↳ All selected com units are created in the project structure. The progress is displayed in the PACTware™ status line.

5.6 Editing Com Unit Device Data



Note!

Remote I/O stations can be configured via the PROFIBUS using version 7.2 or earlier of the DTM only. Configuration via the service bus is also supported from DTM version 7.3 onwards.



Editing Com Unit Device Data

1. Right-click on the com unit entry in the project structure.
2. Select **Parameter > Parameterization > Edit device data**.
↳ The **Edit device data** window opens.
3. Make the following settings on the **Structure** tab. Note that the settings must correspond with the actual configuration of the Remote I/O station.
 - Select the backplane type in use in the **Backplane type** field and enter the number of extensions.
 - Highlight the existing power supplies in the **Power supplies** field.
4. Click on **OK**.



Tip

Alternatively, you can load the settings from the com unit by establishing a connection with the com unit and then selecting **Load from Device** on the toolbar.

5.7 Integrating I/O Modules

Only the com unit has been incorporated into the project structure up to now. I/O modules are to be integrated in this step.



Integrating I/O Modules Automatically by Scanning the Topology

Before allowing I/O modules to be installed automatically, there must be at least one com unit in the project structure. The **Backplane type**, **Extensions**, and **Power supplies** com unit parameters must already be configured.

1. Right-click on the entry for the required com unit in the project structure.
2. Establish a connection to the com unit. To do this, choose **Connect**.
↳ The connection is established. The com unit entry appears bold in the project structure as soon as the connection is established.
3. Right-click on the entry for the com unit in the project structure again.
4. Select **Additional Functions > Topology Scan**.
↳ The **Topology Scan** window appears. The search begins automatically. The I/O modules that are found are listed in the same sequence as the slots in the backplane.

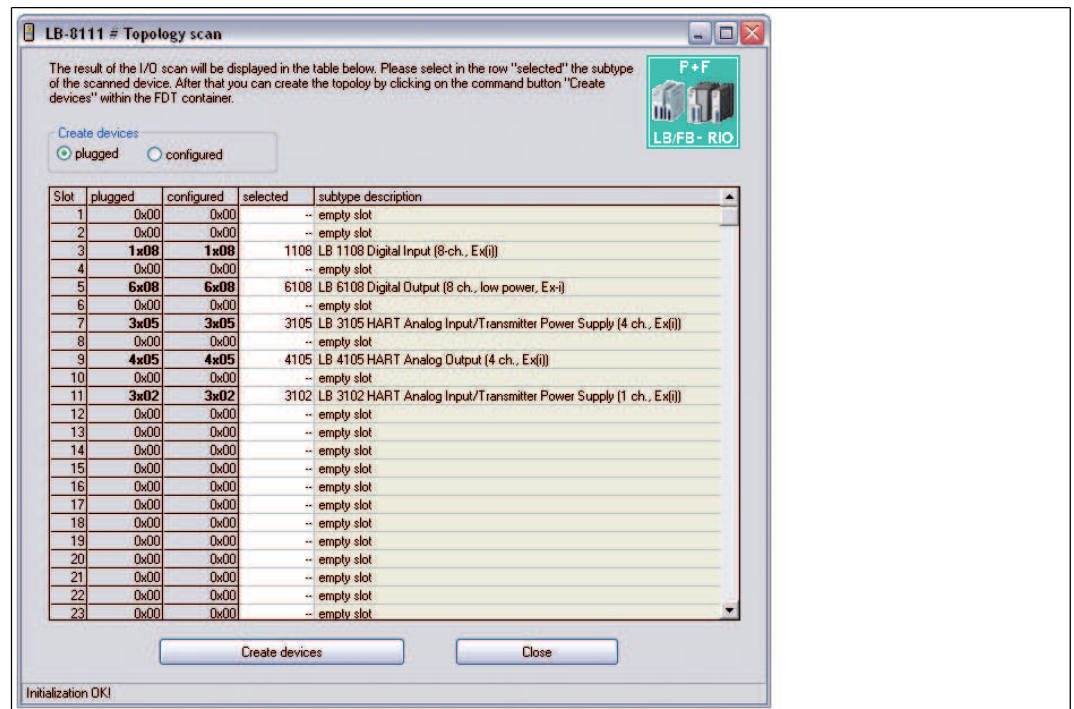

Figure 5.14 Topology scan window with a list of located I/O modules

- The **Connected** column lists the I/O modules as they are actually connected in the backplane.
The **Configured** column lists the I/O modules as they are currently parameterized in the com unit and project structure.
- To integrate the I/O modules in the software in the same way as they are shown in the **Connected** column, choose the **Connected** option. To integrate the I/O modules in the same way as they are shown in the **Configured** column, choose the **Configured** option.
- The **Selected** column allows the type of module to be specified more precisely or the I/O module to be deselected (--). To do so, click the cell in the **Selected** and make a selection. The options depending on the type of module in the **Connected** (or **Configured**) column, depend on which of the **Connected** or **Configured** options you selected in the **Create devices** area. The **Variant information** column contains more detailed information about the selected I/O module.
- To generate the I/O modules as they are shown in the **Selected** column, click on **Create devices**.
↳ The I/O modules will be integrated into the project structure with their standard parameter sets. A progress bar is displayed in the status line of the **Topology Scan** window.

Deleting I/O Modules

- Right-click on the entry for the I/O module in the project structure that you wish to delete from the configuration.
- Select **Remove device**.
- Click on **Yes** in the dialog box.
↳ The I/O module is removed from the configuration.
- Repeat these steps to delete other I/O modules.

5.8 Converting I/O Module Type Retroactively



Note!

This feature is available from DTM version 7.5.1 and higher.

If the incorrect module type has been installed for an I/O module, the module type can be converted retroactively. During conversion, the parameters for the old module type are adopted for the new module type. You can convert a module type only if there is another module type with similar functions, e.g., converting LB1108A to LB1008A. The DTM suggests suitable module types for conversion.

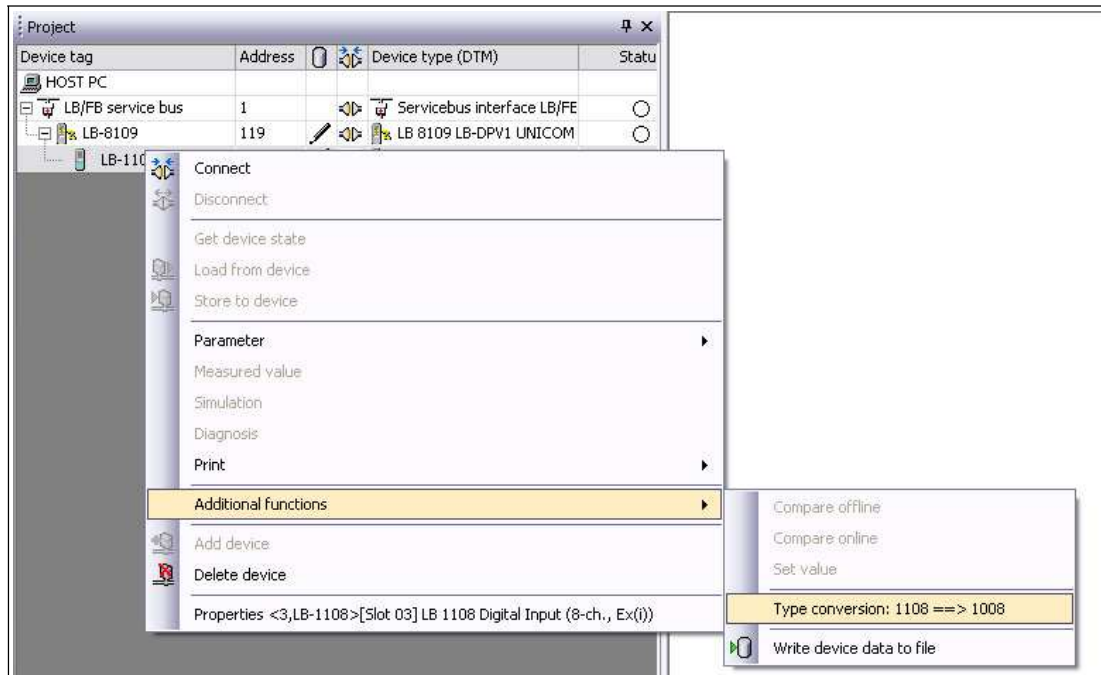

Figure 5.15 Convert module type

Converting I/O Module Type Retroactively

1. Right-click on the I/O module in the project structure that you want to convert.
2. Select **Additional functions > Type Conversion X ==> Y** (X = current module type, Y = possible new module type).

↳ The module type is converted. The parameters of the old module type are retained.

5.9 Configuring HART Communication

The following I/O modules are suitable for communication with intelligent field devices using the HART protocol.

- 3x02, 3x03, 3x05, 3x06
- 4x02, 4x05, 4x06
- 7x04



Note!

Note the connection layout of the I/O modules. The connection layout differs depending on whether you are using a 2-wire transmitter, 3-wire transmitter or 4-wire transmitter (externally powered) with the I/O module.

Make sure that the output current during HART communication is between 4 mA ... 20 mA.

Data transfer is based on the transmission of frequency packages according to the Bell standard (1200 Hz = 1, 2200 Hz = 0). The frequency packages are modulated onto the 4 mA ... 20 mA signals by the I/O modules in frequency shift keying mode. Two types of communication are possible.

- Communication with a handheld connected to the I/O module terminals for hazardous location. The required 250 Ω communication resistance is built into all analog I/O modules.
Transmitters that do not use the standard HART protocol may need to be reset after they have finished operating. This problem can be identified when the measurement circuit freezes.
- Communication via the PROFIBUS with the com unit using the acyclic DP-V1 services and with the I/O modules without auxiliary equipment. Use a suitable communication program to access the functions of the HART field devices via the PROFIBUS. Field device manufacturers provide separate DTMs for their field devices so that all the functions of the field devices are accessible via the PROFIBUS using the HART protocol. In addition, PROFIBUS class 2 masters can be used if the process control system does not provide HART functionality.

The DTM LB/FB contains a HART communication component that, together with a HART DTM (e.g., **Generic HART DTM** from the PACTware™ standard setup), allows access to the connected HART devices.

Configuring HART Communication

Before setting up HART communication, the project file must be open and include a com unit and one or more I/O modules with HART support.

1. Right-click on an I/O module with HART support in the project structure.
2. Select **Add Device**.

↳ The **Device for** window opens displaying a list of available DTMs. Device manufacturers usually offer DTMs that are compatible with the relevant device. If you do not have any device-specific DTMs, you can set up the devices using a **generic HART DTM**.

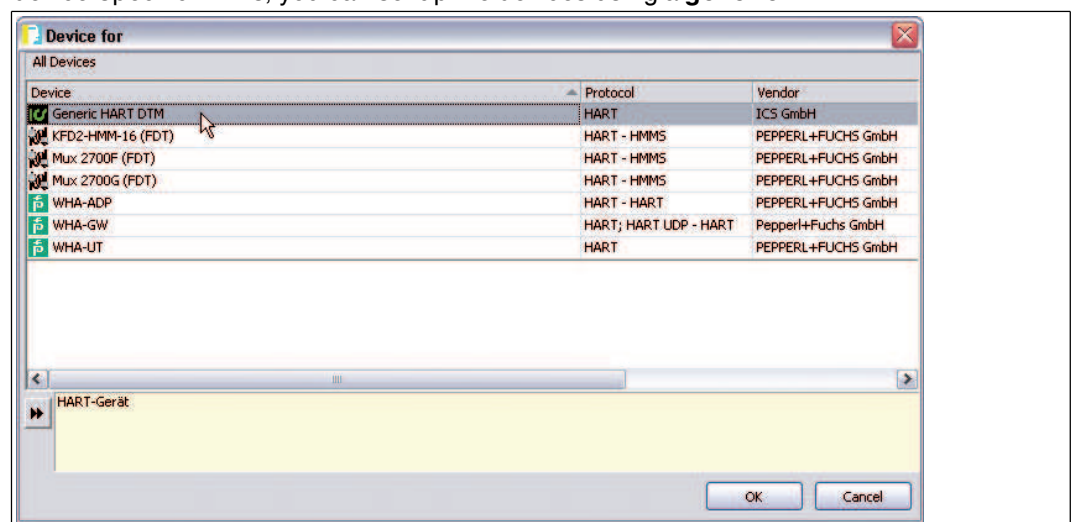

Figure 5.16 **Device for** window

3. Select the required HART DTM in the **Device for** window and then click on **OK**.

↳ If you are using a multichannel I/O module, the **Channel Selection** window opens. If you are using a single-channel I/O module, you do not need to select a channel.

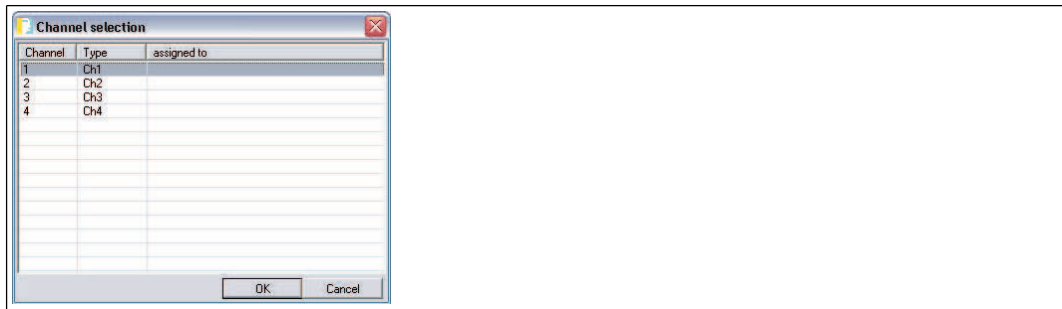

Figure 5.17 Channel Selection window

4. Select the required I/O module channel from the list and then click on **OK**.

↳ The HART DTM is added to the project structure under the corresponding I/O module.

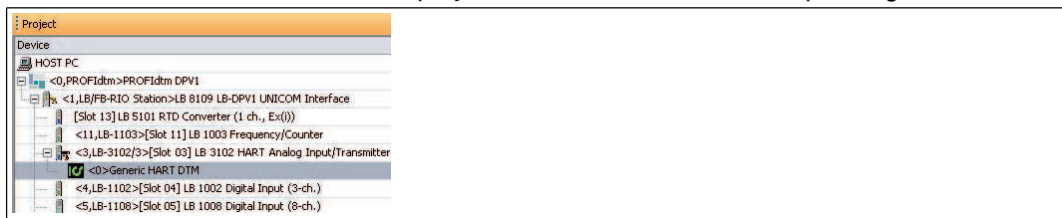

Figure 5.18 HART DTM in the PACTware™ project view

5. Right-click on the HART DTM.
6. To activate the different HART device functions, establish a connection with the field device and select the required function, e.g., **Measured value > Measured Values Display**.

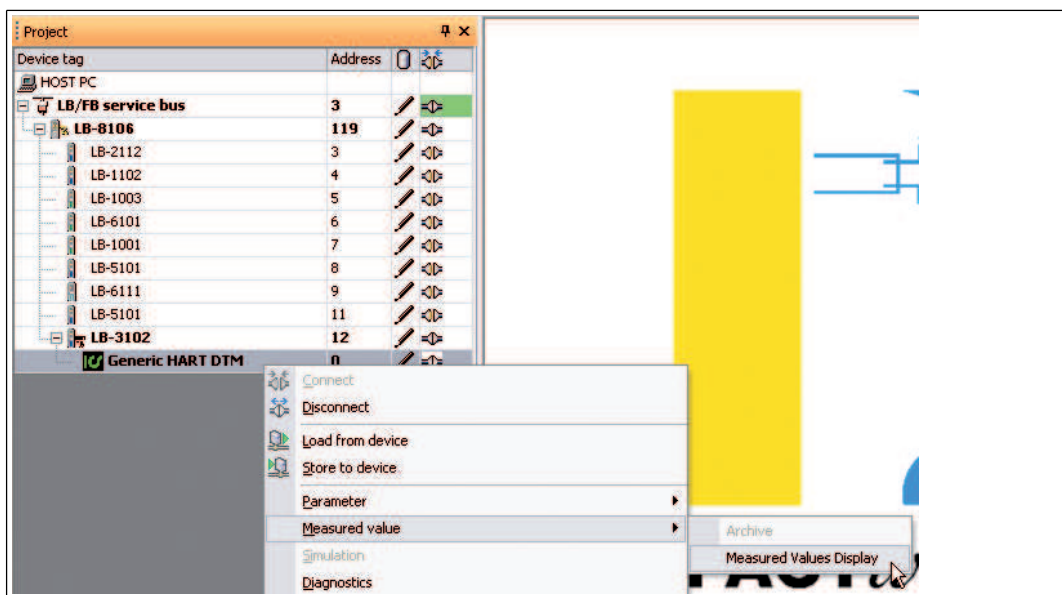
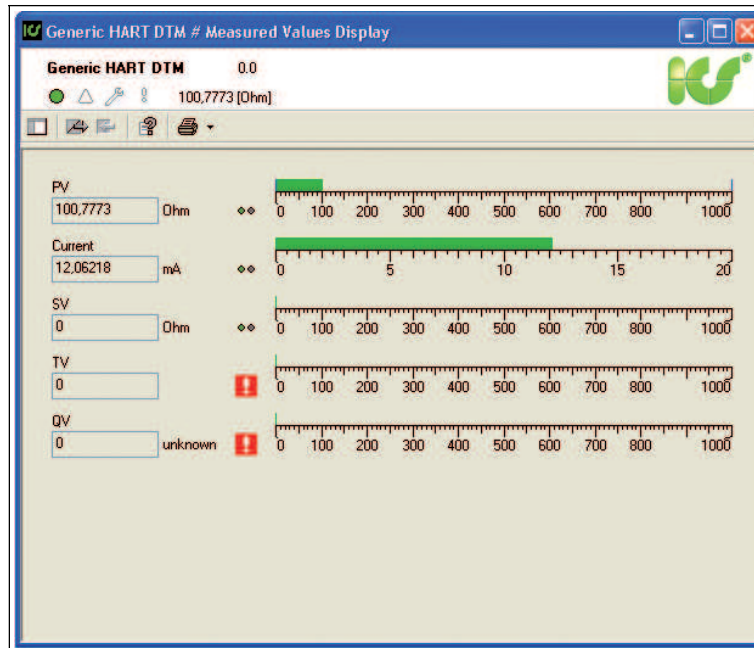

Figure 5.19 Opening the Measured Values Display

Depending on the functionality of the HART DTM, the HART device can be edited online and offline. You can display and modify parameters, read diagnostic information, and set simulations. If you have selected a generic HART DTM, only standard functions are available. Additional device-specific functions can only be accessed using a device-specific DTM from the device manufacturer.

Figure 5.20 Measured Values Display **Generic HART DTM****Note!****Com units from firmware version 6 and higher**

Com units from firmware version 6 and higher are equipped with HART cross-talk suppression. The cross-talk suppression makes sure that HART channels are signaled as faulty only if the fault is pending for more than 500 ms. The channel data is frozen until the HART signal faults are rectified. The channel becomes active again as soon as the HART fault is rectified.

In addition, the com unit resets I/O modules that have experienced a HART communication fault.

Practical Experiences

The following restrictions were found during tests in relation to HART communication.

- HART communication with measuring transmitters is possible in the operating range 4 mA ... 20 mA. Some measuring transmitters go overrange (22 mA) or underrange (< 4 mA) when there is no input signal, e.g., in the event of a lead breakage. In this situation, HART communication with this measuring transmitter is often not possible.
- There are measuring transmitters that work with device-specific HART commands. When device-specific, non-HART compliant commands are executed, the error counter in the I/O module may reach saturation depending on the I/O module firmware and hardware. In this case, perform a reset of the I/O module.
- In rare cases, field devices without HART support such as plunger coil positioners may generate HART-like signals in 20 mA loops. These signals can be produced by random vibrations at the installation location of the field device. The I/O module's error counter can therefore overflow and the I/O module cuts communication with the com unit. In this case, perform a reset of the I/O module.
You can avoid this problem by using an I/O module without HART support or by deactivating the HART function on the affected channel.

5.10 Displaying and Editing Parameters

5.10.1 Activating and Deactivating the Configuration Mode

In order for the Remote I/O station to be configured via the DTM, the configuration mode must be activated.

Activating and Deactivating the Configuration Mode

1. Right-click on the com unit in the project structure.
2. Select **Connect** to establish a connection to the com unit.
 - ↳ A connection to the com unit is established. The entry appears in bold in the project structure once the connection is established.
3. To activate configuration mode, in the com unit context menu select **Additional functions > Activate configuration mode link**.

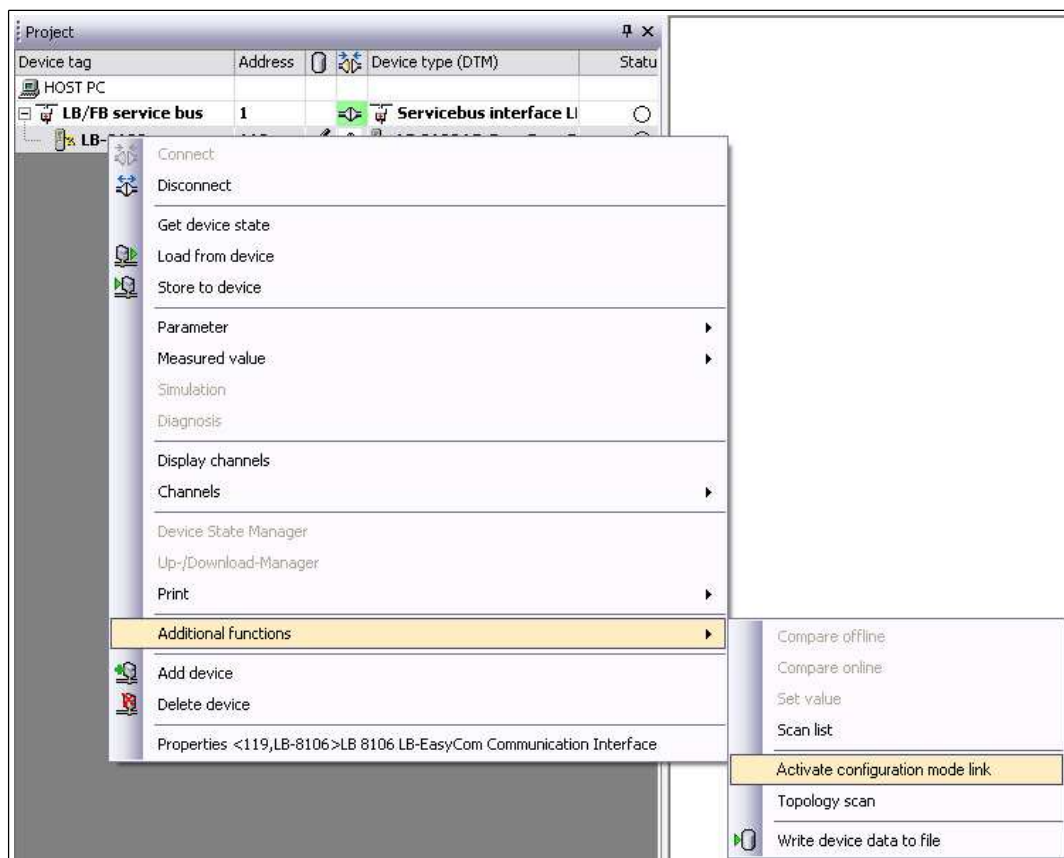

Figure 5.21 Activate configuration mode

↳ The DTM automatically checks whether the configuration mode requirements are fulfilled. If the requirements are not fulfilled, for example because the com unit is in the DataExchange state, then configuration mode is automatically deactivated again.

4. To deactivate configuration mode, in the com unit context menu select **Additional functions > Deactivate configuration mode**.

↳ Configuration mode is deactivated.

If the connection to the com unit is interrupted, the configuration mode is automatically deactivated.

5.10.2 Loading and Displaying Parameters



Loading Parameters

1. Right-click on the com unit in the project structure.
2. Choose **Connect**.
 - ↳ A connection to the com unit is established. The entry appears in bold in the project structure once the connection is established.
3. Right-click on the com unit entry in the project structure.
4. Select **Read Data from Device**.
 - ↳ A dialog box appears.
5. Click on **No** to load the com unit parameters only. Click on **Yes** to load both the com unit parameters and the parameters of all I/O modules.
 - ↳ If you select **Yes**, another dialog box appears. Click on **Yes** to confirm this box. The data is then loaded. If the I/O modules in the project structure do not correspond with the actual slot configuration, a warning appears.



Displaying Parameters

1. Right-click on the entry for a com unit or an I/O module in the project structure.
2. Choose **Connect**.
 - ↳ The connection is established. The entry appears in bold in the project structure once the connection is established.
3. Right-click on the entry for the connected device in the project structure.
4. Select **Parameter > Parameterization > Edit device data**.
 - ↳ The device data window for the selected component is opened. It displays the available parameters.



Note!

The device data windows contain parameters that are not adjustable via the PROFIBUS class 1 master. These parameters are set to default automatically by the master.

5.10.3 Changing Com Unit Parameters

The **Edit device data** window for the com unit contains the tabs **Structure**, **PROFIBUS I**, **PROFIBUS II** and **Info**.



Note!

The parameters in the **PROFIBUS I** and **PROFIBUS II** tabs have no effect on the maintenance and commissioning, i.e., if no PROFIBUS communication exists. Once PROFIBUS communication via the PROFIBUS class 1 master is active again, these parameters are overwritten with the values of the PROFIBUS class 1 master. Parameter values that are not or only partially set by the PROFIBUS class 1 master are overwritten with default values. For this reason, these parameters are not dealt with in the following.

Exception: If the PROFIBUS class 1 master does not support address configuration, the PROFIBUS addresses can be set as a preparatory measure in the **PROFIBUS I** tab.



Opening Device Data Window of the Com Unit

1. Right-click on the com unit entry in the project structure.
2. Select **Parameter > Parameterization > Edit device data**.
 - ↳ The **Edit device data** window opens.

"Structure" Tab

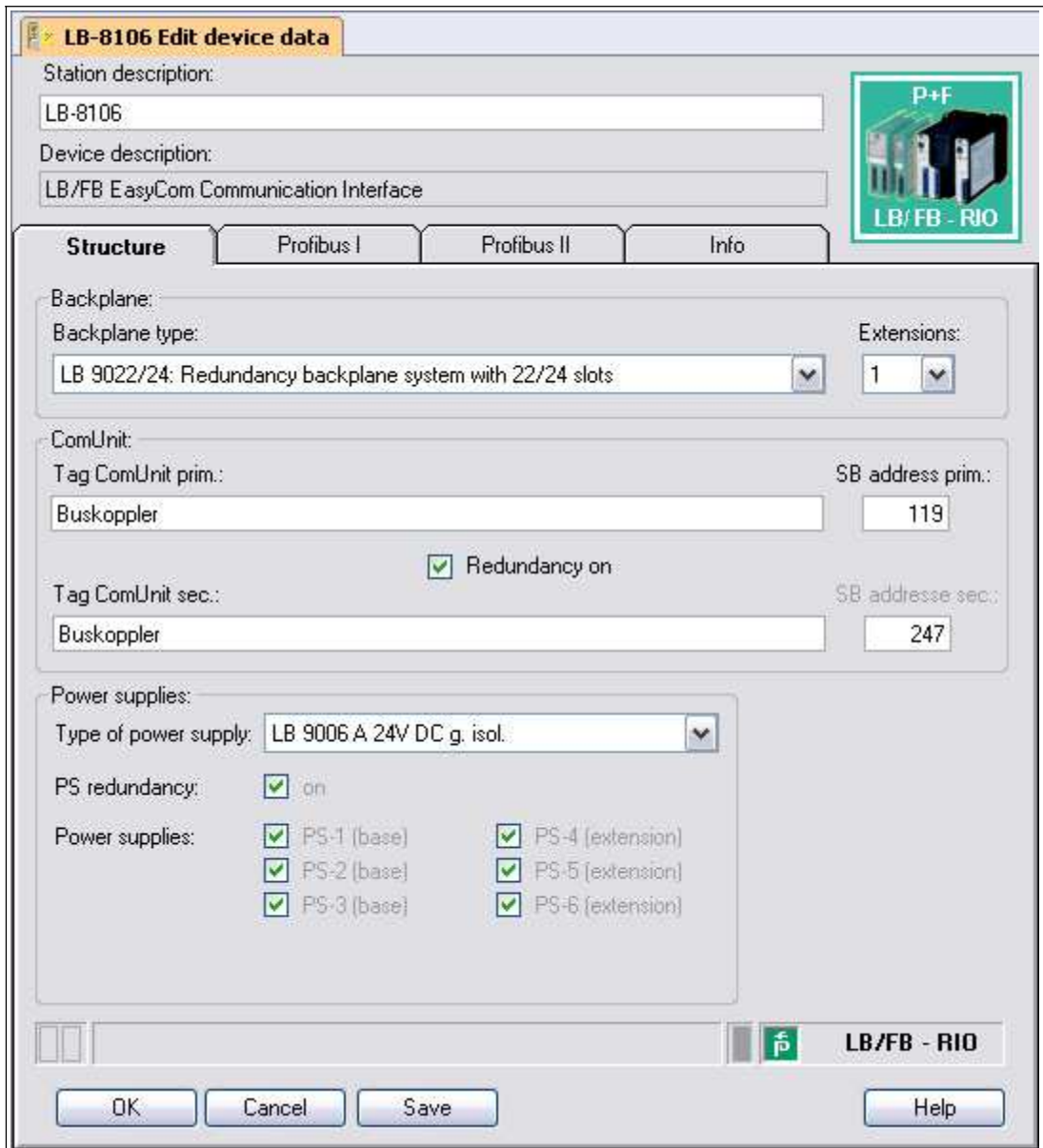

Figure 5.22 Structure tab

Field	Explanation
Station description	This field is prepopulated. You can overwrite this description with a new station description if you wish (max. 32 characters).
Device description	Contains a description of the com unit and cannot be edited.
Backplane type	Select the backplane type used in the remote I/O station. This setting determines which power supply types are available, as well as the number of possible extensions. The "redundant system with 22/24 module slots (LB 9022/24)" type is selected in the example.
Extensions	Specify here whether an extension to the base backplane is available. 0: no extension available 1: extension available The selection of available extensions depends on the backplane system and may vary from 0 ... 5 extensions. Example: You are using the base backplane LB9022 with 22 slots. If you select 1, a remote I/O station with 46 slots is configured (base backplane with 22 slots + extension backplane LB 9024 with 24 slots).
Primary com unit tag	Contains the description for the primary com unit. Enter up to 32 characters.
SB address pri.	Enter the service bus address of the primary com unit.
Enabling redundancy	The check box can only be edited offline without any active connection to the Remote I/O station. If Redundancy on is enabled, additional entry options for the secondary com unit tag and the service bus address appear on the Structure tab. The status of this check box affects the adjustment options for the connected power supplies displayed in the Power supplies area (redundancy = com unit and power supply redundancy).
Secondary com unit tag	Contains the description for the secondary com unit (redundant com unit). Enter up to 32 characters. This field only appears when Redundancy on is activated.
SB address sec.	Contains the service bus address of the secondary com unit. This address is allocated automatically based on the address of the primary com unit and cannot be edited. This field only appears when Redundancy on is activated.
Type of power supply	Select the power supply. The options depend on the item selected in the Backplane type drop-down list.
Power supply redundancy	If the overall Remote I/O station is supplied via redundant power supplies, the PS redundancy auxiliary function can be enabled in DTMs version 7.5.1 and higher. If PS redundancy is enabled, the remaining power available will be calculated such that the station is still adequately supplied in the event of a power supply failure. If Redundancy on is enabled, power supply redundancy is set automatically.
Connected power supplies	Activate the check boxes to specify which connected power supplies you wish to monitor. The number of check boxes depends on the settings in the Type of power supply , Backplane type , and Extensions drop-down lists. In redundant systems, power supply monitoring is automatically activated for all existing power supply slots and cannot be deactivated (power supply redundancy).

**Note!****Information on Redundancy**

Further information about redundancy (basics, redundancy types, power supply redundancy) can be found in the hardware manual for LB or FB Remote I/O systems.

"PROFIBUS I" Tab



Figure 5.23 PROFIBUS I tab

Field	Explanation
Primary com unit (bus address)	<p>If the master does not support PROFIBUS address planning, you can enter the bus addresses of the primary com unit here. This field can be edited only when you enable the Selection option for fieldbus address check box in the Edit application mode window.</p> <p>To call up the Set application mode window, right-click on the com unit in the project structure and select Other features > Set application mode.</p>
Secondary com unit (bus address)	<p>Configure the bus address of the secondary com unit. This field can be viewed only if you have enabled the Redundancy on check box in the Structure tab. This field can be edited only when you enable the Selection option for fieldbus address check box in the Edit application mode window.</p> <p>To call up the Set application mode window, right-click on the com unit in the project structure and select Other features > Set application mode.</p> <p>If Line redundancy is enabled in the Redundancy mode area, the address of the secondary com unit is identical to that of the primary com unit.</p>

"PROFIBUS II" Tab

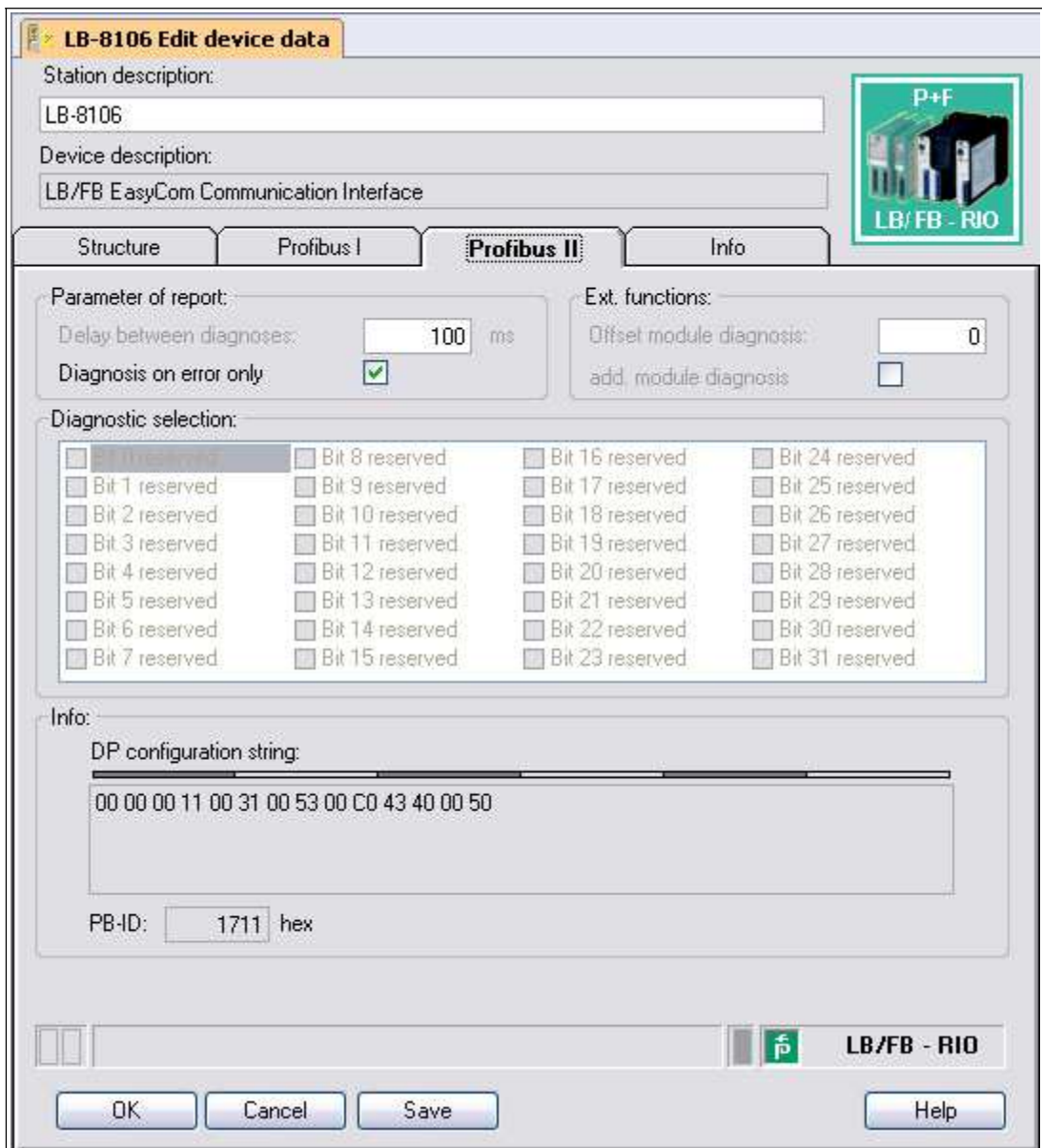

Figure 5.24 PROFIBUS II tab

Field	Explanation
DP configuration string	Sets out the current DP configuration. The entry in this field is based on the arrangement of I/O modules on the backplane. The information is updated automatically when an I/O module is added or removed and cannot be edited. For more information on the DP configuration string, see chapter 4.6.
PB ID	Shows the PROFIBUS identification number. The PROFIBUS ID is defined automatically as soon as the com unit is added and it cannot be edited.

"Info" Tab

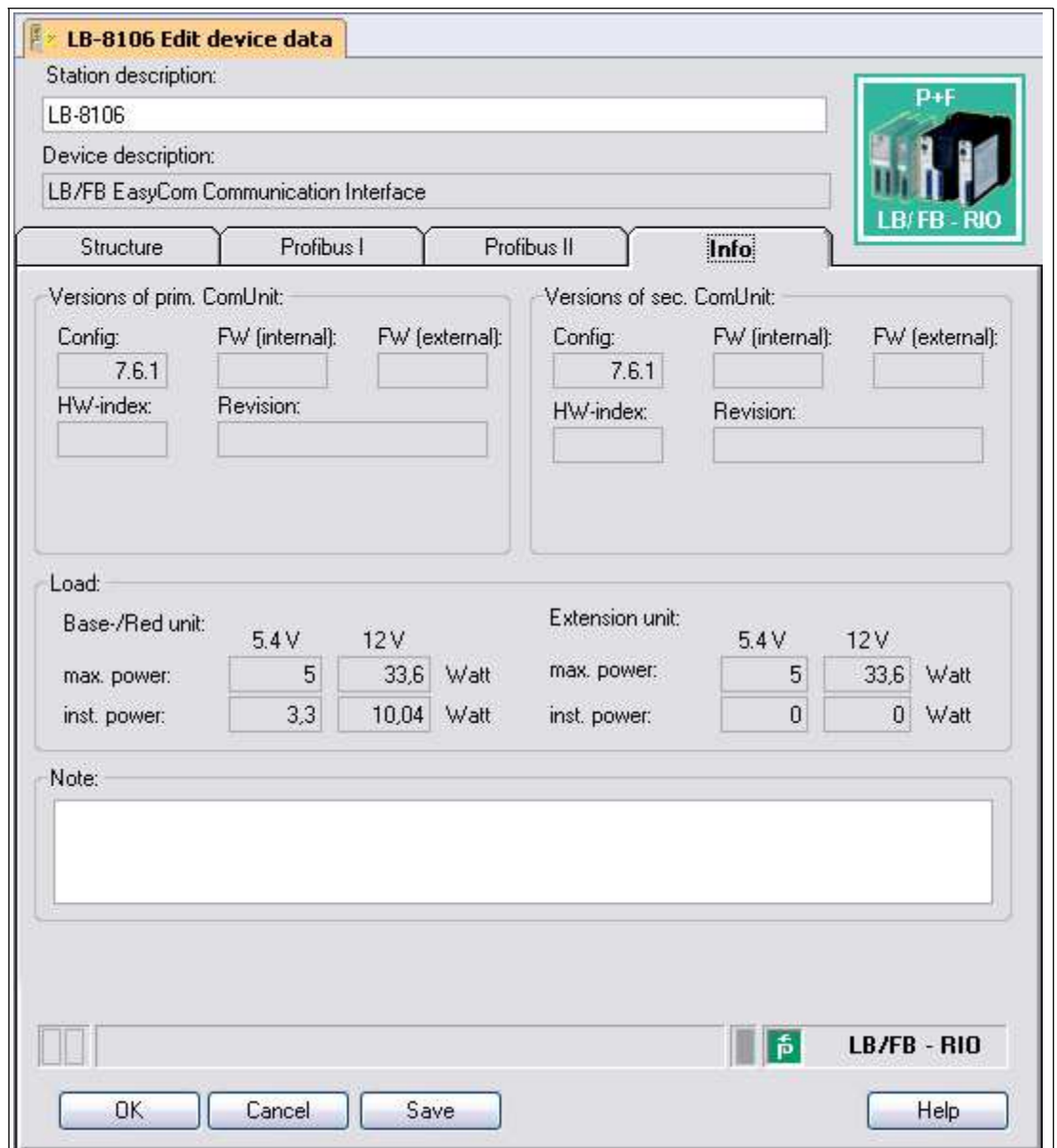

Figure 5.25 Info tab

The **Info** tab contains information on com units and power supplies.

Field	Explanation
Primary com unit versions	This area contains the following non-editable fields that contain information on the primary com unit. Config: DTM version FW (Internal): firmware version PIC (cannot be changed) FW (External): firmware version (can be changed by service) HW Index: com unit hardware version (currently not supported) Revision counter: revision status of the parameters
Secondary com unit versions	This area behaves in the same way as the primary com unit versions area. This area can be viewed only if you have enabled the Redundancy on check box in the Structure tab.

200337 2016-03

Field	Explanation
Load	This area includes non-editable fields that contain information about the load. Power rating values appear in the fields after the slots on the backplane are populated with I/O modules. During configuration, the Device Type Manager (DTM) identifies any potential overload situations and flags this to the user. The user is then prevented from adding another I/O module to the backplane in the case of overload.
Note	Enter any text. The text is saved in the database and not in the com unit.

5.10.4 Changing I/O Module Parameters



Opening the "Edit Device Data" Window

1. Right-click on the I/O module in the project structure.
2. Select **Parameter > Parameterization > Edit device data**.

↳ The **Edit device data** window opens.

The **Edit device data** window for the I/O module is divided into several tabs.

The **General** tab contains parameters that affect the whole I/O module, as well as information on the I/O module and available channels. The structure of the **General** tab is the same for all I/O modules.

General Channel 1 Channel 2 Channel 3

Module type: 2101 Description: LB 2101 Digital Output(22 V / 315 Ohm) + 2 Input (Ex(i)) (22 V)

Module tag: LB-2101

Slot: 3 Modul active:

Channel information:

Channel tag	LFD	Inv.	Function	Operating mode
Ch 1: Kanal ZXY	<input checked="" type="checkbox"/>	<input type="checkbox"/>	DOUT	Normal
Ch 2: Kanal ZXY	<input checked="" type="checkbox"/>	<input type="checkbox"/>	DIN	Normal
Ch 3: Kanal ZXY	<input checked="" type="checkbox"/>	<input type="checkbox"/>	DIN	Normal

Note:

OK Cancel Save Help

Figure 5.26 **General** tab

Field	Explanation
Module type	This field displays the four-digit type designation for the I/O module. This field can not be edited.
Description	This field displays the description of the I/O module. This field can not be edited.
Module tag	Enter any name for the I/O module. The maximum length is 32 characters.
Slot	This field indicates the slot number of the I/O module. The slot number cannot be edited. If you wish to position the I/O module in another slot, delete it from the project structure, and reinsert it in another slot. Note that the layout in the tree structure must match the layout on the backplane.
Module active	Enable or disable this check box to activate or deactivate the I/O module. <ul style="list-style-type: none"> ■ If you deactivate the I/O module, the module is present in the synchronous data traffic, but does not generate measured values or diagnostic data. This option is useful for process control systems that do not allow extensions during ongoing operation. In this case, any I/O module can be preconfigured, even if it has not yet been plugged into the backplane. This ensures that the I/O module is already included in the DP configuration string. The I/O module can be upgraded in the relevant slot on the backplane at a later point in time and can be activated using the Module Active option without the need for a PROFIBUS restart. ■ If you activate the I/O module, it operates normally and generates measured values and diagnostic data.
Channel tag	The names of the I/O module channels can be found here. You can enter the names on the Channel X tab in the Channel Tag field of the relevant I/O module. The Channel Tag fields cannot be edited on the General tab.
LFD	The check box is present only when the I/O module has line fault detection. Here you can see whether line fault detection is activated for each channel. You can activate/deactivate line fault detection on the Channel X tab for the relevant I/O module. The Line Fault Detection check boxes cannot be edited on the General tab.
Inv.	This check box appears with digital I/O modules only. The check box indicates whether signal negation is active on each channel. You can activate or deactivate signal negation on the Channel X tab of the relevant I/O module. The Signal Negation check boxes cannot be edited on the General tab.
Channel type	This field indicates the channel type for each channel. It cannot be edited. DIN = DI = digital input DOUT = DO = digital output AIN = AI = analog input AOOUT = AO = analog output
Operating mode	This field indicates the operating mode for each channel. You can set the operating mode on the Channel X tab for the relevant I/O module. The Operating Mode fields cannot be edited on the General tab.
Note	You can enter a comment here. The maximum text length is 256 characters. The comment is saved in the database only and not in the I/O module. The comment applies to the entire I/O module and also appears on the other tabs in the window.



There are also one or more **Channel X** tabs where X stands for the channel number, e.g., **Channel 1**, **Channel 2**, or **Channel 3**. Set channel-specific parameters on the **Channel X** tab.

Editing "Channel X" of Digital I/O Modules

Representative of all digital I/O modules, the individual channel parameters are explained using the example of the digital input LB1*08 and FB1*08. Some I/O modules support only parts of the illustrated channel parameter. If a parameter or a parameter value is not supported, then this parameter is either not visible or cannot be edited.

Figure 5.27 Channel 1 tab

Field	Explanation
Channel tag	Enter a description for the channel. You can enter up to 32 characters.
Channel active	The check box shows whether or not the channel is active. This check box is dependent on the Module active check box in the General tab and cannot be edited here.
Channel type	This field indicates the channel type for each channel. It cannot be edited. DIN = DI = digital input DOUT = DO = digital output AIN = AI = analog input AOUT = AO = analog output
Channel type	Depending on the I/O module, this field shows the signal type, e.g., counter, current, resistance, NAMUR, or 24 V.
Operating mode	Choose between Normal and Simulation . In normal operation, the current input signal is transferred to the process control system. An input signal is simulated in simulation mode. You can adjust the simulated input signal in the Simulation value area.

Field	Explanation
Error mode	Define the behavior of the I/O module in the event of an error. Substitute values transferred in the event of an error have the invalid data status in DTM version 7 or higher. Current value: The signal is transferred unchanged from the field in spite of the error. Substitute value: A substitute value is transferred. You can set the substitute value in the Substitute Value area. Last valid value: The last value that was valid before the fault occurred is transferred.
Signal negation	To invert the signal, activate Signal negation . When signal negation is active, a logical 1 may become 0.
Line fault detection	Enable line fault detection to monitor the connection at the field end. If an error occurs (e.g., lead breakage or short circuit), the error is reported via the status area for the process value and the substitute value strategy configured under Error mode is initiated.
ON delay	You can use the ON delay to filter out short pulses. Enter a value in ms to shorten a signal change from 0 to 1. 
OFF delay	You can use the OFF delay to extend short pulses. Enter a value in ms to extend a signal change from 1 to 0. 
Substitute value	Define a substitute value for when there is a fault. Choose either 0 or 1 as the substitute value. The substitute value is always transferred with the Invalid data status.
Simulation value	Define the simulation value and the status of this value. The simulation value is transferred if you activate "Simulation" mode. Choose either 0 or 1 as the simulation value. Choose between the Data OK and Invalid data status.
Special channel parameters	–
Note	You can enter a comment here. The maximum text length is 256 characters. The comment is saved in the database only and not in the I/O module. The comment applies to the entire I/O module and also appears on the other tabs in the window.

Editing "Channel X" of Analog I/O Modules LB/FB3* and LB/FB4*

Representative for analog modules whose channels can be operated as 0/4 mA ... 20 mA input or output, the channel parameters are explained here using the example of the HART transmitter power supply/input isolator LB3*05 and FB3*05. Some I/O modules only support parts of the illustrated channel parameter. If a parameter or a parameter value is not supported, then this parameter is either not visible or cannot be edited.

The screenshot shows the configuration window for Channel 1. The window has tabs for General, Channel 1, Channel 2, Channel 3, and Channel 4. The Channel 1 tab is active.

Channel tag: Kanal 3005 Channel active

Channel properties: Function: AI Channel type: Current

Function modes: Operating mode: Normal Error mode: Current value

Signal handling: Line fault detection: On

Measuring/Scaling:

	phys. value:		Scaling:	
Lower limit:	0,000 mA	<===>	0	Points
Begin of range:	4,000 mA	<===>	10000	Points
End of range:	20,000 mA	<===>	50000	Points
High limit:	24,000 mA	<===>	60000	Points

Alarm points: Short: 21,00 mA Broken wire: 1,00 mA

Special adjustments: HART options: HART on internal scan on

Note:

LB/FB - RIO

Buttons: OK, Cancel, Save, Help

Figure 5.28 Channel 1 tab

Field	Explanation
Channel tag	Enter a description for the channel. You can enter up to 32 characters.
Channel active	The check box shows whether or not the channel is active. This check box is dependent on the Module active check box in the General tab and cannot be edited here.
Channel type	This field indicates the channel type for each channel. It cannot be edited. DIN = DI = digital input DOUT = DO = digital output AIN = AI = analog input AOUT = AO = analog output
Channel type	Depending on the I/O module, this field shows the signal type, e.g., counter, current, resistance, NAMUR, or 24 V.
Operating mode	Choose between Normal and Simulation . <ul style="list-style-type: none"> ■ LB/FB3* In normal operation, the current input signal is transferred to the process control system. An input signal is simulated in simulation mode. You can adjust the simulated signal using the Extended button. ■ LB/FB4* In normal operation, the current bus signal is processed and output by the I/O module. A bus signal is simulated in simulation mode. The simulated bus signal is processed and output. You can adjust the simulated bus signal using the Extended button.
Error mode	Define the behavior of the I/O module in the event of an error. <ul style="list-style-type: none"> ■ LB/FB3* Substitute values transferred in the event of an error have invalid data status in DTM version 7 or higher. Current value: The signal is transferred unchanged from the field in spite of the error. The signal may also be a simulated signal. Substitute value: A substitute value is transferred. You can adjust the substitute value using the Extended button. Last valid value: The last value that was valid before the fault occurred is transferred. ■ LB/FB4* Once the watchdog time has detected a bus fault or when the com unit receives values with the data invalid status, the outputs adopt substitute values in accordance with the substitute value strategy. The substitute value strategy is not activated by line faults in the output circuit. Current value: The signal from the process control system is transferred unchanged in spite of the error. The signal may also be a simulated signal. Substitute value: A substitute value is transferred. You can adjust the substitute value using the Extended button. Last valid value: The last value that was valid before the fault occurred is transferred.
Extended	This button takes you to a window with more channel settings. Here you can adjust the simulation value for the operating mode and the substitute value for the error mode .

Field	Explanation
Line fault detection	<p>Activate line fault detection to monitor the connection at the field end.</p> <ul style="list-style-type: none"> ■ LB/FB3* If an error occurs (e.g., lead breakage or short circuit), the error is reported via the status area for the process value and the substitute value strategy configured under Error mode is initiated. ■ LB/FB4* If an error occurs (e.g., lead breakage or short circuit), the error is reported via the status area for the process value.
Short circuit	Enter the threshold value for short circuit detection, e.g., 21 mA. When the current strength exceeds this value, the line fault detection function reports a short circuit.
Lead breakage	Enter the threshold value for the lead breakage detection, e.g., 1 mA. When the current strength falls below this value, the line fault detection signals a lead breakage.
Measuring range/scaling	<p>Define the scaling for the measured values. The values are calculated in the Phys. size column using the values in the Scaling column.</p> <p>You can define the scaling yourself.</p> <p>Lower limit: indicates the smallest value to be transferred, e.g., 0 points or 0 mA</p> <p>Start of range: indicates the value equal to 0 %, e.g., 10,000 points and 4 mA</p> <p>End of range: indicates the value equal to 100 %, e.g., 50,000 points or 20 mA</p> <p>Upper limit: indicates the largest value to be transferred, e.g., 60,000 points at 24 mA</p>
HART on	<p>This check box is available for I/O modules with HART support only. This check box can be edited only when the firmware-dependent Individual HART channel deactivation function is enabled.</p> <p>Activate or deactivate HART communication to the channel. Deactivate HART communication if no HART-compatible device is connected. This saves time available for communication with other HART devices.</p>
Internal scan on	<p>This check box is available for I/O modules with HART support only. This check box can be edited only when the firmware-dependent Deactivate automatic scanning of HART ID, tag and variables function is enabled.</p> <p>This check box only appears when HART communication is activated. Activate or deactivate the automatic scanning of IDs, tags, and variables for HART communication. All active HART channels are scanned automatically by default, such that HART data is retrieved and saved for quicker external access.</p>
Note	You can enter a comment here. The maximum text length is 256 characters. The comment is saved in the database only and not in the I/O module. The comment applies to the entire I/O module and also appears on the other tabs in the window.

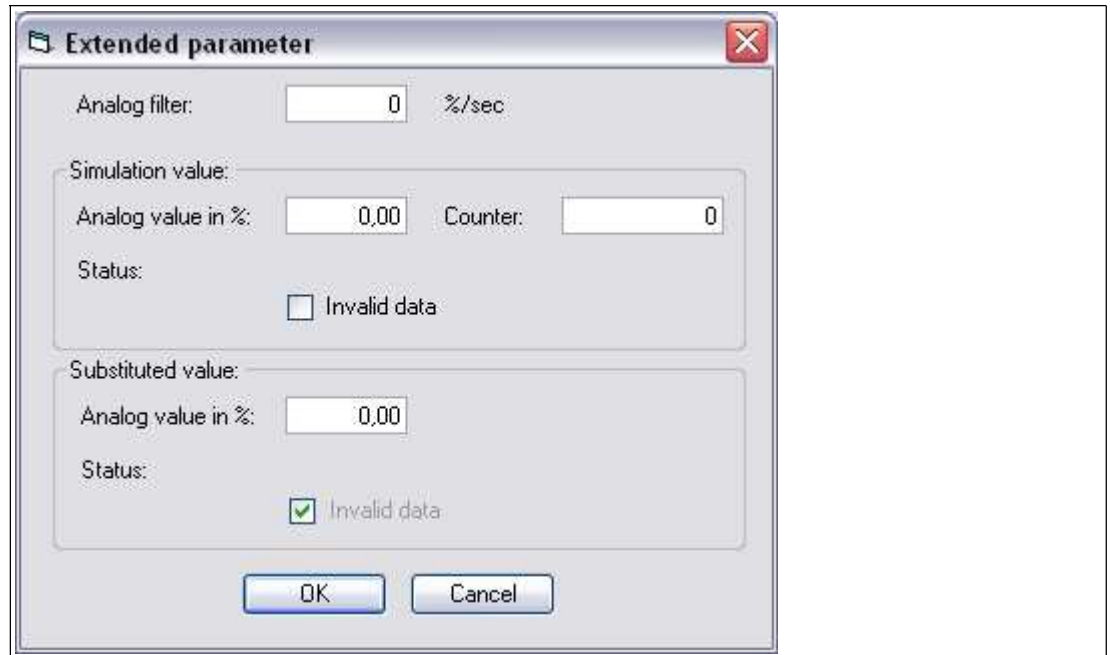

Figure 5.29 Extended Parameters window

Field	Explanation
Analog filter	The analog filter for damping the signal can be activated if the input signals fluctuate. Enter a value in % per second for defining the rate of change of the input value. The measurement range is used as the reference value. Enter the value 0 here to deactivate the filter.
Analog value as % (simulation value)	The simulation value is transferred if you have selected the Simulation operating mode. Enter a simulation value in % relating to the measurement range (-25% ... 125%).
Data invalid (simulation value)	Define the status of the simulation value. <ul style="list-style-type: none"> ■ LB/FB3* If you activate the check box, the simulation value is transferred with the status data invalid. ■ LB/FB4* If you activate the check box, the simulation value is transferred with the status data invalid and the substitute value strategy is initiated.
Analog value as % (substitute value)	The substitute value is transferred when an error occurs and you have selected the Substitute value error mode. Enter a substitute value in % relating to the measurement range (-25% ... 125%).
Data invalid (substitute value)	This field can not be edited. The substitute value is always transferred with the Invalid data status.

Editing "Channel X" of Analog I/O Modules LB/FB5*

Representative for analog modules whose channels can be used for measuring temperature, voltage or resistance, the channel parameters are explained using the example of the thermocouple converter LB5*02 or FB5202. Some I/O modules only support parts of the illustrated channel parameter. If a parameter or a parameter value is not supported, then this parameter is either not visible or cannot be edited.

Figure 5.30 Channel 1 tab

Field	Explanation
Channel tag	Enter a description for the channel. You can enter up to 32 characters.
Channel active	The check box shows whether or not the channel is active. This check box is dependent on the Module active check box in the General tab and cannot be edited here.
Channel type	This field indicates the channel type for each channel. It cannot be edited. DIN = DI = digital input DOUT = DO = digital output AIN = AI = analog input AOUT = AO = analog output
Channel type	Depending on the I/O module, this field shows the signal type, e.g., counter, current, resistance, NAMUR, or 24 V.
Operating mode	Choose between Normal and Simulation . In normal operation, the current input signal is transferred to the process control system. An input signal is simulated in simulation mode. You can adjust the simulated signal using the Extended button.

Field	Explanation
Error mode	Define the behavior of the I/O module in the event of an error. Substitute values transferred in the event of an error have the status Invalid data in DTM version 7 or higher. Current value: The signal is transferred unchanged from the field in spite of the error. Substitute value: A substitute value is transferred. You can adjust the substitute value using the Extended button. Last valid value: The last value that was valid before the fault occurred is transferred.
Extended	This button takes you to a window with more channel settings. Here you can adjust the simulation value for the operating mode and the substitute value for the error mode .
Line fault detection	Enable line fault detection to monitor the connection at the field end. If an error occurs (e.g., lead breakage or short circuit), the error is reported via the status area for the process value and the substitute value strategy configured under Error mode is initiated.
LFD delay	This field only appears when Line fault detection is enabled. Specify the number of measuring cycles during which a measured value must be free of errors before the value is signaled as good. This function can be used for suppressing loose contacts, for example.
Scan rate internal CJC	This field is only visible if you have selected an external cold junction from the measuring methods in the drop-down list. Specify how often the cold junction temperature should be measured in relation to the actual measurement. If you specify the ratio 1:20, for example, the cold junction temperature is measured after every twentieth thermocouple measurement. The setting is effective for the duration of the measuring cycle. The more frequently the cold junction temperature is measured, the longer a measuring cycle lasts.
Measuring range/scaling	Define the scaling for the measured values. The values are calculated in the Phys. size column using the values in the Scaling column. You can define the scaling yourself. The Lower limit indicates the smallest transferable value (e.g., 0 points or underrange). The Start of range indicates the value equivalent to 0% (e.g., 10,000 points or start of measuring range). The End of range indicates the value equivalent to 100% (e.g., 50,000 points or end of measuring range). The Upper limit indicates the largest transferable value (e.g., 60,000 points or overrange).
Measuring method	<ul style="list-style-type: none"> ■ Choose between internal and external cold junction for voltage inputs (e.g., thermocouple). ■ Select 2-, 3-, or 4-wire configuration for resistance inputs (e.g., Pt100). ■ Choose from the various function types (frequency with/without direction, 32-bit counter with/without direction, 12-bit counter with/without direction or frequency + 32-bit counter with/without direction) for counters.
Line resistance or ext. cold junction	Enter the line resistance of the spur for internal cold junctions and the thermostat temperature for external cold junctions.
Sensor	Select the sensor that is connected to the I/O module. Depending on the sensor, the correct linearization is automatically used.
Temperature unit	This option is not visible if you have selected mV in the Sensor drop-down list. Select the temperature unit for the start of range, end of range, and measured value.

Field	Explanation
Line filter	Select a filter to compensate for system-related interference (50 Hz and 60 Hz).
Note	You can enter a comment here. The maximum text length is 256 characters. The comment is saved in the database only and not in the I/O module. The comment applies to the entire I/O module and also appears on the other tabs in the window.

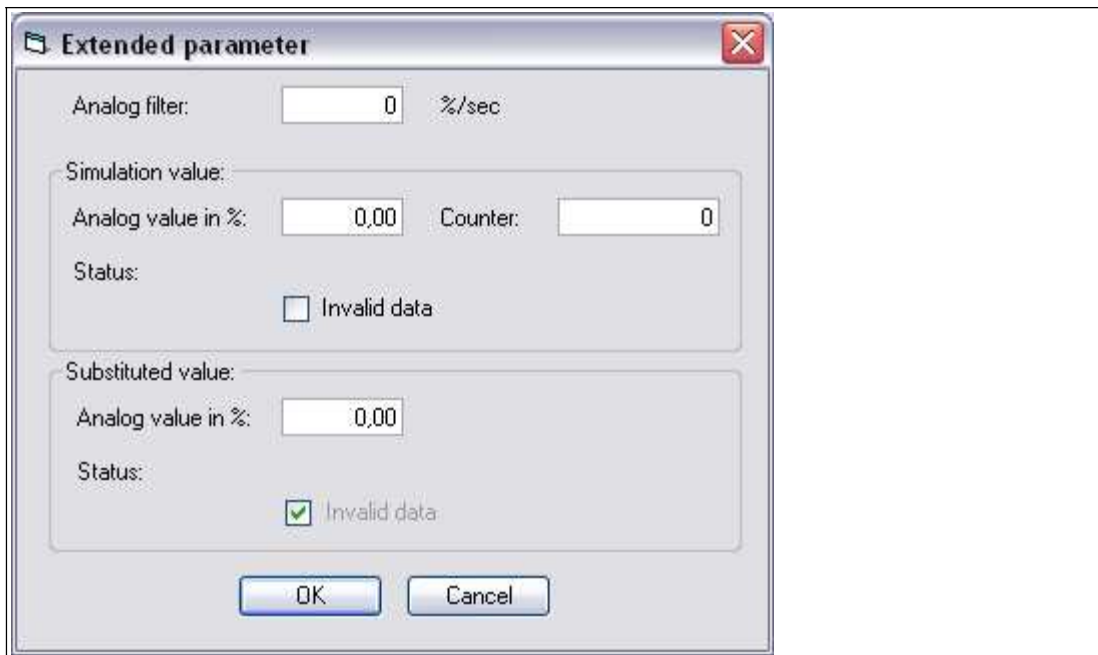

Figure 5.31 Extended Parameters window

Field	Explanation
Analog filter	The analog filter for damping the signal can be activated if the input signals fluctuate. Enter a value in % per second for defining the rate of change of the input value. The measurement range is used as the reference value. Enter the value 0 here to deactivate the filter.
Analog value as % (simulation value)	The simulation value is transferred if you have selected the Simulation operating mode. Enter a simulation value in % relating to the measurement range (-25% ... 125%).
Data invalid (simulation value)	Define the status of the simulation value. If you enable the check box, the simulation value is transferred with the status Data invalid .
Analog value as % (substitute value)	The substitute value is transferred when an error occurs and you have selected the Substitute value error mode. Enter a substitute value in % relating to the measurement range (-25% ... 125%).
Data invalid (substitute value)	This field can not be edited. The substitute value is always transferred with the Invalid data status.

5.11 Displaying Measured Values and Diagnostic Data

In addition to the remote I/O station parameters, the DTM provides process values and diagnostic information. These are displayed on the measured values display of the relevant component:

- The measured values display of the com unit contains diagnostic information for the complete remote I/O station.
- The measured values displays of the I/O modules contain process values and module-specific diagnostic information.



Opening the "Show Measured Value" window

1. Right-click on the entry for the required component in the project structure.
2. Choose **Connect**.
 - ↳ The connection is established. The entries appear in bold in the project structure once the connection is established. The connection status is also indicated by an icon.
3. Right-click on the entry for the connected device in the project structure.
4. In the context menu, select **Measured Value > Show Measured Value**. If the command is not available, there is no connection to the device.
 - ↳ The **Show Measured Value** window opens.

A description of the different measured values displays can be found in the following chapters.

- Com Unit Diagnostics Functions
See chapter 7
- Measured Values Display of Digital I/O Modules
See chapter 5.11.1
- Measured Values Display of Analog I/O Modules
See chapter 5.11.2

5.11.1 Measured Values Display of Digital I/O Modules

Depending on the module type (digital input, digital output, relay contact output), the measured values display for digital I/O modules differs in the number of channels displayed.

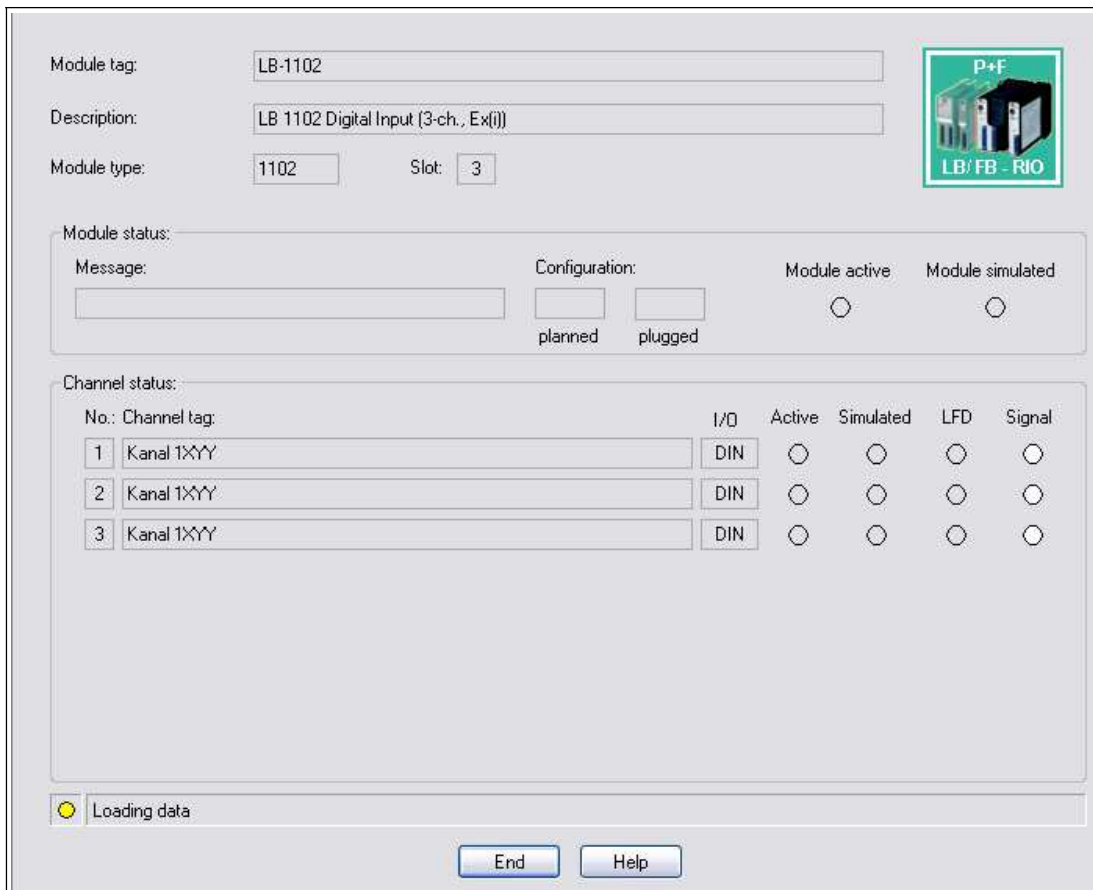

Figure 5.32 Show Measured Value window for digital modules

Field	Explanation
Module tag	This field displays the name of the I/O module. This field cannot be edited.
Module description	This field displays the description of the I/O module. This field cannot be edited.
Module type	This field displays the four-digit type designation for the I/O module. This field cannot be edited.
Slot	This field indicates the slot number of the I/O module. The slot number cannot be edited. If you wish to position the I/O module in another slot, delete it from the project structure, and reinsert it in another slot. Note that the layout in the tree structure must match the layout on the backplane.
Module messages	This field displays messages from the I/O module. Error messages are highlighted red.
Configuration	The Planned field indicates which I/O module is included in the active com unit configuration. The Connected field indicates which I/O module is actually plugged in on the backplane. If the scheduled and actual I/O module types differ, the fields appear red.
Module active	When the display lights up yellow, the I/O module is active. When the display is gray, the I/O module is deactivated.
Module simulated	When the display lights up yellow, at least one channel of the I/O module is in simulation mode.

200337 2016-05

Field	Explanation
Channel tag	This field displays the name of the channel in question. The associated channel number is shown to the left of the field and the channel type to the right. <ul style="list-style-type: none"> ■ DIN = digital input ■ DOUT = digital output
Active	When the display lights up yellow, the associated channel is active. As soon as an I/O module is active, all channels are also active.
Simulated	When the display lights up yellow, the associated channel is in simulation mode.
LFD	This display only appears if the I/O module has a line fault detection function. If the display lights up red, there is a line fault in the relevant channel. With some I/O modules, a distinction can be made between a lead breakage and a short circuit. In such cases, a B for lead breakage or K for short circuit is displayed in addition to the LFD indicator.
Signal	This display shows the current field signal. If the display lights up yellow, a signal 1 is transferred. If the display lights up gray, a signal 0 is transferred.
Status bar	The status indication flashes yellow in rhythm with the data transfer. If a communication error occurs, the display lights up red. The communication status is displayed as a text message in the text box.

5.11.2 Measured Values Display of Analog I/O Modules

Depending on the module type (analog input, analog output, frequency input, temperature input, voltage input), the measured values display for analog I/O modules differs in the number of channels displayed.

The **Overview** tab provides an overview of the status and the measured values of all the input or output channels of the I/O module.

Module tag: LB-3105

Description: LB 3105 HART Analog Input/Transmitter Power Supply (4 ch., Ex(I))

Module type: 3105 Slot: 11

Module status:

Message:

Configuration: planned plugged

Module active:

Module simulated:

Channel status:

Overview Channel 1 (AI) Channel 2 (AI) Channel 3 (AI) Channel 4 (AI)

No.:	Channel tag:	Function:	Active	Simulated	LFD	Value:
1	Kanal 3105	AI	<input type="radio"/>	<input type="radio"/>	<input type="radio"/>	mA
2	Kanal 3105	AI	<input type="radio"/>	<input type="radio"/>	<input type="radio"/>	mA
3	Kanal 3105	AI	<input type="radio"/>	<input type="radio"/>	<input type="radio"/>	mA
4	Kanal 3105	AI	<input type="radio"/>	<input type="radio"/>	<input type="radio"/>	mA

Loading data

End Help

Figure 5.33 Show Measured Value window for analog modules

Field	Explanation
Module tag	This field displays the name of the I/O module
Module description	This field displays the description of the I/O module. This field can not be edited.
Module type	This field displays the four-digit type designation for the I/O module. This field can not be edited.
Slot	This field indicates the slot number of the I/O module. The slot number cannot be edited. If you wish to position the I/O module in another slot, delete it from the project structure, and reinsert it in another slot. Note that the layout in the tree structure must match the layout on the backplane.
Module messages	This field displays messages from the I/O module. Error messages are highlighted red.
Configuration	The Planned field indicates which I/O module is included in the active com unit configuration. The Connected field indicates which I/O module is actually plugged in on the backplane. If the scheduled and actual I/O module types differ, the fields appear red.

Field	Explanation
Module active	When the display lights up yellow, the I/O module is active. When the display is gray, the I/O module is deactivated.
Module simulated	When the display lights up yellow, at least one channel of the I/O module is in simulation mode.
Channel tag	This field displays the name of the channel in question. The associated channel number is shown to the left of the field and the channel type to the right. <ul style="list-style-type: none"> ■ AIN = analog input ■ AOUT = analog output
Active	When the display lights up yellow, the associated channel is active. As soon as an I/O module is active, all the channels are also active.
Simulated	When the display lights up yellow, the associated channel is in simulation mode.
LFD	This display appears only if the I/O module has a line fault detection function. If the display lights up red, there is a line fault in the relevant channel. The line fault is specified in more detail on the Input/Output X tabs.
Value	This field displays the current measured value in the relevant unit.
Status bar	The status indication flashes yellow in rhythm with the data transfer. If a communication error occurs, the display lights up red. The communication status appears in the text box to the right of the display in the form of a text message.

In addition to the **Overview** tab, the **Channel status** area contains one or more **Input X** and **Output X** tabs where X stands for the channel number, e.g., input 1, input 2.

The **Input X** and **Output X** tabs display the values of each individual input or output channel separately. The measured value is shown in figures on one side and as bars on the other, and the line fault detection status is specified in more detail.

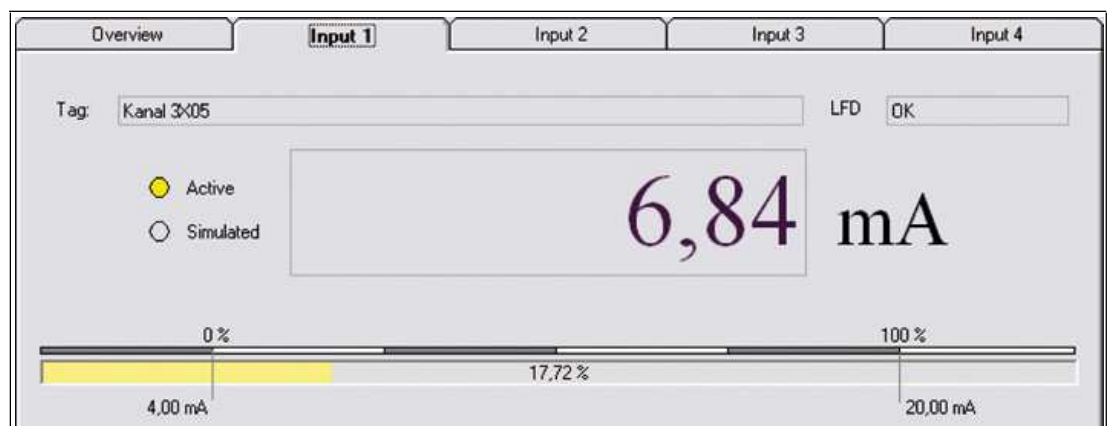

Figure 5.34 Input 1 tab

6 Configuring I/O Modules

The following sections describe the properties and configuration options for the I/O modules.

The sections are always similar in structure.

- Brief description of the relevant I/O module with block diagram
- Information on resolution, measuring time, and cycle time
- Information about data transmission and bit structure within the data telegram
- Information about line fault detection
- Description of adjustment options

6.1 Configuring Dual Width I/O Modules

All GSD/GSE-based configurations use single width I/O modules. Dual width modules that occupy two slots are configured in the same way as single width modules, followed by an empty slot.

Be aware that the last slot may not be an empty slot. If the last I/O module is a dual width module, configure this in the same way as a single width module and omit the following empty slot.



Example!

The 8-channel digital input 1x08 with the module identifier 11 is entered in the PROFIBUS configuration string. The additional slot occupied by the dual width module is automatically treated as an empty slot and has the code 00 in the PROFIBUS configuration string.

The table below shows how 1- or 2-channel and multichannel I/O modules appear in the PROFIBUS configuration string.

Example DP Configuration String

Slot	I/O module	DP config. code
1	Digital input, 2-channel	10
2	Digital output plus 2 inputs	30
3 + 4	Digital output, 8-channel	31 00
5	Digital input, 2-channel	10
6 + 7	Digital input, 8-channel	11 00
8	Analog Input	50



Note!

Different Slot Assignment for Redundant LB Backplanes

Slots 1 and 2 on redundant LB backplanes are reserved for the redundant com unit, regardless of whether a redundant com unit is actually present or not. Configure the I/O modules for these backplanes from slot 3.

6.2 Setting Substitute Values for Fault Occurrences

In the event of a fault, I/O modules can accept defined substitute values, e.g., in the event of a failure in bus communication or a line fault in the sensor circuit.

Substitute Values for Inputs

Some I/O modules support the **Substitute value** parameter, for which the following options are available. Substitute values are always transferred with the **Invalid data** status.

- **Current value**
The current value is transferred.
- **Substitute value**
The substitute value defined in the device data of the I/O module is transferred.
- **Last valid value**
The last valid value received prior to the occurrence of the fault is transferred.

Substitute Values for Outputs

Once the watchdog has detected a bus fault or when the com unit receives values with the **Invalid data** status, the outputs adopt substitute values in accordance with the substitute value strategy. The substitute value strategy is not activated by line faults in the output circuit.

The substitute value strategy takes effect if the watchdog is activated. If the watchdog is disabled, the output values remain frozen in the event of a bus communication failure. See chapter 4.3.3

The following options are available for the **Substitute value** parameter.

- **Current value**
The current value being transferred by the process control system is output in spite of the **Invalid data** status.
- **Substitute value**
The substitute value defined in the device data of the I/O module is output.
- **Last valid value**
If a new incoming value has the **Invalid data** status, the last valid value is output.

If communication between the I/O module and the com unit fails, the affected outputs are deactivated after approx. 500 ms.

Responses

The diagram below illustrates an example of a digital output to demonstrate the data flow resulting from different situations and parameter settings.

- In normal mode, the data is transferred directly from the com unit to the output.
- If an inversion has been configured, the signals are inverted beforehand according to their parameter setting.
- If an error occurs, the relevant substitute values, the last valid values, or the current values are transferred to the outputs.

All processes are applied to each channel.

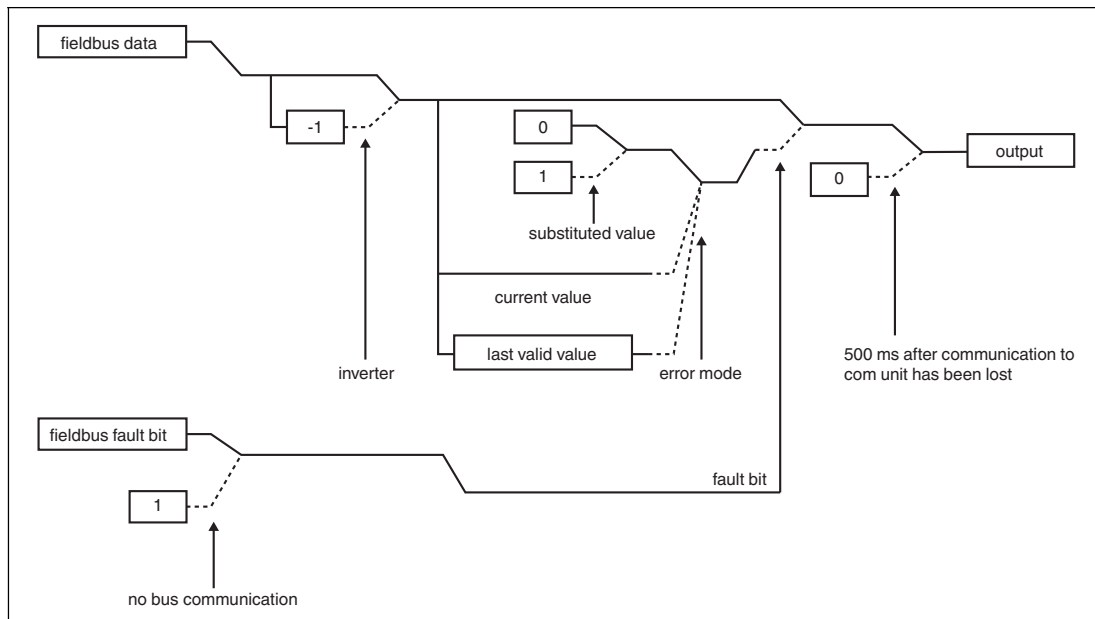

Figure 6.1 Data flow from the com unit to a digital output

Solid line for normal position
Dashed line for if-then action
3 options in error mode

6.3 HART Communication

The following I/O modules are suitable for communication with intelligent field devices using the HART protocol.

- 3x02, 3x03, 3x05, 3x06
- 4x02, 4x05, 4x06
- 7x04



Note!

Note the connection layout of the I/O modules. The connection layout differs depending on whether you are using a 2-wire transmitter, 3-wire transmitter or 4-wire transmitter (externally powered) with the I/O module.

Make sure that the output current during HART communication is between 4 mA ... 20 mA.

For details on setting up the HART communication, see chapter 5.9.

6.4 LB1*01, FB1*01 Digital Input

6.4.1 Description

Versions

- LB1001, digital input, not intrinsically safe
- FB1301, digital input, increased safety terminals
- LB1101, digital input, intrinsically safe
- FB1201, digital input, intrinsically safe

Features

- Occupies 1 slot on the backplane
- Suitable sensors: mechanical contacts, NAMUR proximity switches, 2-wire initiators
- Number of channels: 2

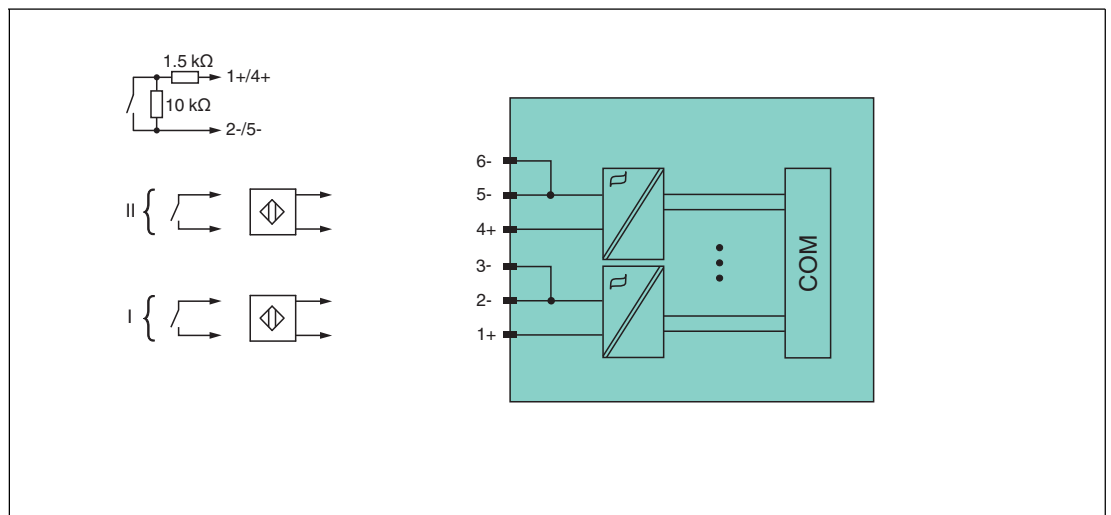

Figure 6.2 Block diagram LB1*01, FB1*01

Refer to the corresponding data sheet and operating instructions for further information.

6.4.2 Measuring Time and Cycle Time

The maximum input frequency of the signals is 50 Hz. However, the measurability of the input statuses is dependent on the cycle time of the data traffic on the bus, e.g., only 1 Hz with a sampling time of 500 ms.

Adjust short signals to the sampling cycles of the process control system by extending the signals using the configurable off delay. The signals are transmitted to the com unit every 6.5 ms irrespective of the sampling interval of the process control system.

6.4.3 Data Transfer

Data is transferred as specified in the PROFIBUS specification.

Successful PROFIBUS communication requires that the configuration, in particular the DP configuration string, in the master and the remote I/O station are identical. The configuration parameters are stored in the GSD/GSE file.

If the GSD/GSE file can be incorporated into the master, the DP configuration code for the relevant I/O module is copied automatically. If the GSD/GSE file cannot be incorporated, the configuration parameters must be entered in accordance with the table in this chapter. In addition to the GSD/GSE file, there are drivers available for further integration into various masters. The drivers provide the signals for the remote I/O station in processed format, meaning a manual integration of the I/O data in the data structures of the master is unnecessary.

Bit Structure within the Data Telegram

DP configuration code 10		
Byte	Bit	Description
Input byte 1	0	Status channel 1
	1	Line fault detection channel 1 (0 = OK, 1 = error)
	2	Status channel 2
	3	Line fault detection channel 2 (0 = OK, 1 = error)
	4 ... 7	Empty
Output bytes		Without output bytes

6.4.4 Line Fault Detection

With NAMUR proximity switches, the line fault detection can detect a line breakage or short circuit and can be switched off on a channel-by-channel basis.

If you are using mechanical contacts, deactivate line fault detection or connect the mechanical contact at the installation location using an additional resistor circuit. Using the resistor circuit, the electronic circuit can distinguish between a closed switch and a short circuit. The resistor circuit is available as an accessory.

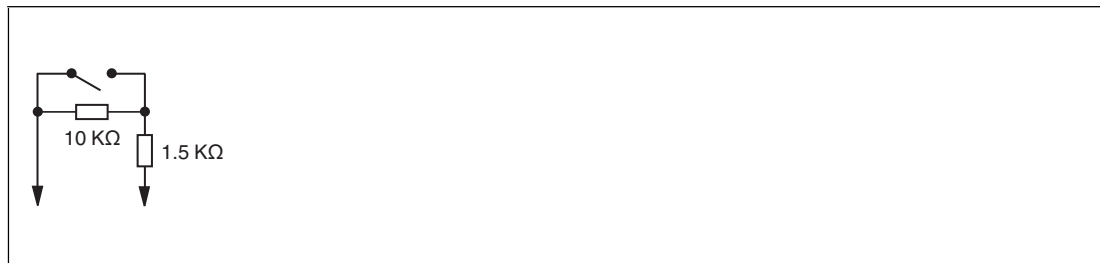

Figure 6.3 Resistor network for line fault detection

6.4.5 Editing Device Data

All I/O module parameters that can be configured via the PROFIBUS class 1 master are listed below. See chapter 4

If the PROFIBUS class 1 master is not yet ready for operation, e.g., during partial commissioning, the remote I/O station can be configured with the help of the DTM and an external FDT framework application such as PACTware™. See chapter 5

If you are operating a master that has drivers or libraries, you do not need to worry about the octet strings. You only need to enter the relevant parameters.

All parameters are valid for each channel.

DP configuration string: 0x10
parameter string: 0x11, data_1, data_2

Data_1, data_2 (channel 1, channel 2)

Bit	Parameters	Selection
0	Line fault detection	0 = off 1 = on
1	Inverter	0 = off 1 = on
2 ... 3	ON delay	0 = off 1 = 10 ms 2 = 100 ms 3 = 1000 ms
4 ... 5	OFF delay	0 = off 1 = 10 ms 2 = 100 ms 3 = 1000 ms
6 ... 7	-	-

Line fault detection

For NAMUR proximity switches, the line fault detection can detect line breakages or short circuits. The connection at the field end cannot be monitored for contact inputs without additional resistance circuitry.

Inverter

Choose between positive or negative logic for the digital signal.

ON delay

You can use the ON delay to filter out short pulses. Enter a value in ms to shorten a signal change from 0 to 1.



OFF delay

You can use the OFF delay to extend short pulses. Enter a value in ms to extend a signal change from 1 to 0.



Preferred Parameter Values

Parameters	Values
Line fault detection	Off
Inverter	Off
ON delay	Off
OFF delay	Off

6.5 LB1*02, FB1*02 Digital Input

6.5.1 Description

Versions

- LB1002, digital input, not intrinsically safe
- FB1302, digital input, increased safety terminals
- LB1102, digital input, intrinsically safe
- FB1202, digital input, intrinsically safe

Features

- Occupies 1 slot on the backplane
- Suitable sensors: mechanical contacts, NAMUR proximity switches, 2-wire initiators
- Number of channels: 3

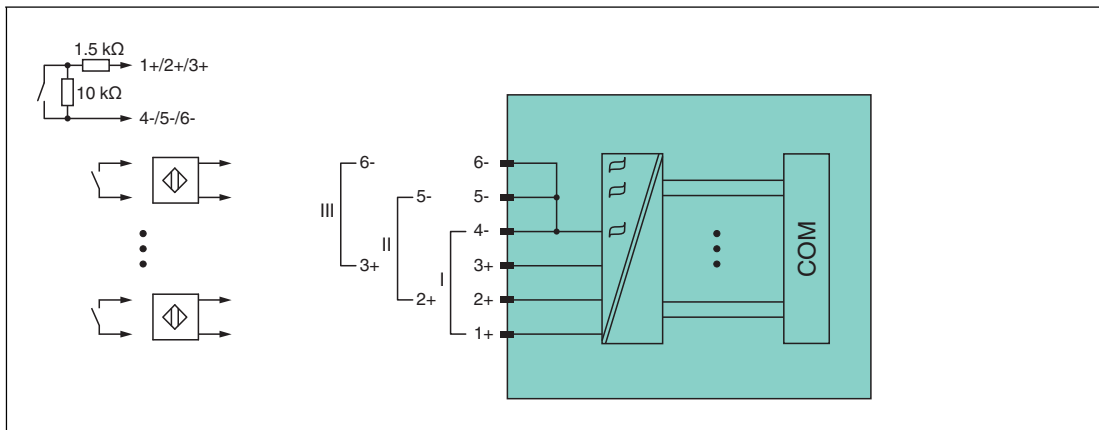

Figure 6.4 Block diagram LB1*02, FB1*02

Refer to the corresponding data sheet and operating instructions for further information.

6.5.2 Measuring Time and Cycle Time

The maximum input frequency of the signals is 50 Hz. However, the measurability of the input statuses is dependent on the cycle time of the data traffic on the bus, e.g., only 1 Hz with a sampling time of 500 ms.

Adjust short signals to the sampling cycles of the process control system by extending the signals using the configurable off delay. The signals are transmitted to the com unit every 6.5 ms irrespective of the sampling interval of the process control system.

6.5.3 Data Transfer

Data is transferred as specified in the PROFIBUS specification.

Successful PROFIBUS communication requires that the configuration, in particular the DP configuration string, in the master and the remote I/O station are identical. The configuration parameters are stored in the GSD/GSE file.

If the GSD/GSE file can be incorporated into the master, the DP configuration code for the relevant I/O module is copied automatically. If the GSD/GSE file cannot be incorporated, the configuration parameters must be entered in accordance with the table in this chapter. In addition to the GSD/GSE file, there are drivers available for further integration into various masters. The drivers provide the signals for the remote I/O station in processed format, meaning a manual integration of the I/O data in the data structures of the master is unnecessary.

Bit Structure within the Data Telegram

DP configuration code 10		
Byte	Bit	Description
Input byte 1	0	Status channel 1
	1	Line fault detection channel 1 (0 = OK, 1 = error)
	2	Status channel 2
	3	Line fault detection channel 2 (0 = OK, 1 = error)
	4	Status channel 3
	5	Line fault detection channel 3 (0 = OK, 1 = error)
	6 ... 7	Empty
Output bytes		Without output bytes

6.5.4 Line Fault Detection

With NAMUR proximity switches, the line fault detection can detect a line breakage or short circuit and can be switched off on a channel-by-channel basis.

If you are using mechanical contacts, deactivate line fault detection or connect the mechanical contact at the installation location using an additional resistor circuit. Using the resistor circuit, the electronic circuit can distinguish between a closed switch and a short circuit. The resistor circuit is available as an accessory.



Figure 6.5 Resistor network for line fault detection

6.5.5 Editing Device Data

All I/O module parameters that can be configured via the PROFIBUS class 1 master are listed below. See chapter 4

If the PROFIBUS class 1 master is not yet ready for operation, e.g., during partial commissioning, the remote I/O station can be configured with the help of the DTM and an external FDT framework application such as PACTware™. See chapter 5

If you are operating a master that has drivers or libraries, you do not need to worry about the octet strings. You only need to enter the relevant parameters.

All parameters are valid for each channel.

DP configuration string: 0x10
parameter string: 0x12, data_1, data_2, data_3

data_1 ... data_3 (channel 1 ... 3)

Bit	Parameters	Selection
0	Line fault detection	0 = off 1 = on
1	Inverter	0 = off 1 = on
2 ... 3	ON delay	0 = off 1 = 10 ms 2 = 100 ms 3 = 1000 ms
4 ... 5	OFF delay	0 = off 1 = 10 ms 2 = 100 ms 3 = 1000 ms
6 ... 7	-	-

Line fault detection

For NAMUR proximity switches, the line fault detection can detect line breakages or short circuits. The connection at the field end cannot be monitored for contact inputs without additional resistance circuitry.

Inverter

Choose between positive or negative logic for the digital signal.

ON delay

You can use the ON delay to filter out short pulses. Enter a value in ms to shorten a signal change from 0 to 1.



OFF delay

You can use the OFF delay to extend short pulses. Enter a value in ms to extend a signal change from 1 to 0.



Preferred Parameter Values

Parameters	Values
Line fault detection	Off
Inverter	Off
ON delay	Off
OFF delay	Off

6.6 LB1*03, FB1*03 Frequency/Counter Input

6.6.1 Description

Versions

- LB1003, frequency/counter input, not intrinsically safe
- FB1303, frequency/counter input, increased safety terminals
- LB1103, frequency/counter input, intrinsically safe
- FB1203, frequency/counter input, intrinsically safe

Features

- Occupies 1 slot on the backplane
- Suitable sensors: frequency, counter, direction of rotation, NAMUR proximity switches, 2-wire initiators, mech. contacts
- Number of channels: 1
 - Channel 1 for frequency measurement or pulse counting
 - Additional input for direction of rotation detection, e.g., for rotating machines, or counting direction, e.g., forwards or backwards. The additional input is not a separate channel.



Note!

Bandwidth limitation

The bandwidth of 15 kHz is not suitable for bouncing contacts. In this case, select a model with a bandwidth of 400 Hz.

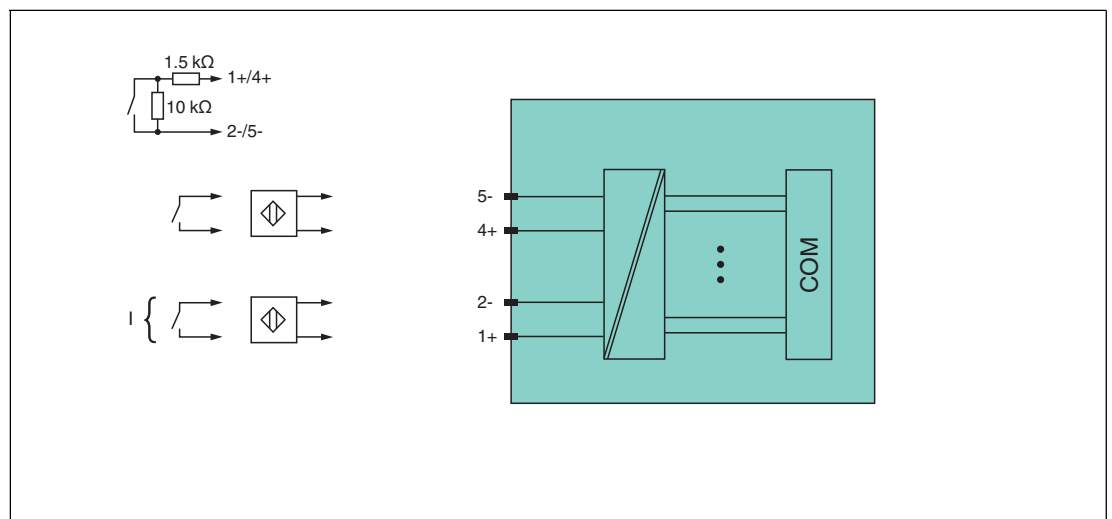

Figure 6.6 Block diagram LB1*03, FB1*03

Refer to the corresponding data sheet and operating instructions for further information.

6.6.2 Measuring Time and Cycle Time

The conversion time is approx. 50 ms. The accuracy of the measured value depends on the cycle time of the data traffic on the bus. The signals are transmitted to the com unit every 6.5 ms irrespective of the measuring time.

6.6.3 Data Transfer

Data is transferred as specified in the PROFIBUS specification.

Successful PROFIBUS communication requires that the configuration, in particular the DP configuration string, in the master and the remote I/O station are identical. The configuration parameters are stored in the GSD/GSE file.

If the GSD/GSE file can be incorporated into the master, the DP configuration code for the relevant I/O module is copied automatically. If the GSD/GSE file cannot be incorporated, the configuration parameters must be entered in accordance with the table in this chapter. In addition to the GSD/GSE file, there are drivers available for further integration into various masters. The drivers provide the signals for the remote I/O station in processed format, meaning a manual integration of the I/O data in the data structures of the master is unnecessary.

The I/O modules offer three function types. The different function types create different data structures in the PROFIBUS data telegram. The frequency input actually represents three devices. All require different drivers to operate in the process control system and all have different DP codes in the GSD file.

If you wish to change the function type of the I/O module, remember that changing the function type means that you will have to change the I/O module. **Changing the function type during operation is therefore only possible with HCiR.** The following function types are available:

- Frequency input up to 15 kHz (with or without direction detection) or 12-bit counter input up to 15 kHz (with or without direction detection)
DP configuration code: **50**
- 32-bit counter input (with or without direction detection)
DP configuration code: **51**
- Combined 32-bit counter and frequency input up to 50 Hz (with or without direction detection)
DP configuration code: **52**

Bit Structure within the Data Telegram

		Frequency input or 12-bit counter input DP configuration code: 50	Combined 32-bit counter input and frequency input DP configuration code: 52	32-bit counter input DP configuration code: 51
Octet	Bit	Meaning	Meaning	Meaning
Input octet 1	0	Status channel 1		High word of counted value (16 bit)
	1	Line fault detection channel 1 (0 = OK, 1 = error)		
	2	Empty		
	3	Empty or direction detection (0 = forwards, 1 = backwards)		
	4 ... 7	Frequency (12 bit) or counter value (12 bit)	Frequency (12 bit)	
Input octet 2	0 ... 7			
Input octet 3... 4		-	High word of counted value (16 bit)	Low word of counted value (16 bit)
Input octet 5... 6		-	Low word of counted value (16 bit)	-
Output octets		Without output octets	Without output octets	Without output octets

200337 2016-03

6.6.4 Line Fault Detection

With NAMUR proximity switches, the line fault detection can detect a line breakage or short circuit and can be switched off on a channel-by-channel basis.

If you are using mechanical contacts, deactivate line fault detection or connect the mechanical contact at the installation location using an additional resistor circuit. Using the resistor circuit, the electronic circuit can distinguish between a closed switch and a short circuit. The resistor circuit is available as an accessory.

If you are using direction detection, connect this input to a resistor circuit. The rotation direction input is ignored for devices without rotation direction detection.

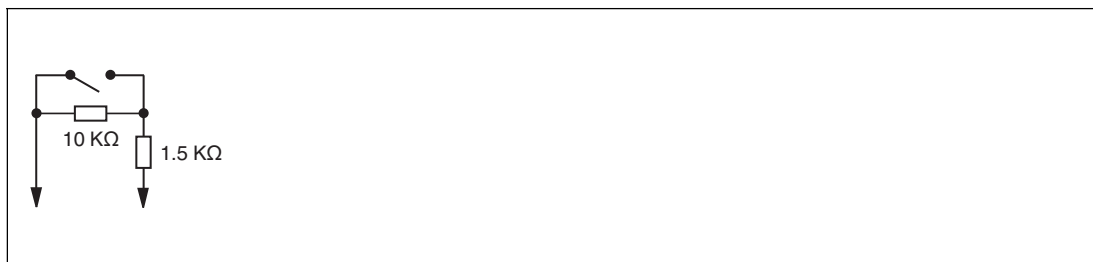

Figure 6.7 Resistor network for line fault detection

6.6.5 Function Types

Frequency Input up to 15 kHz

Frequencies up to 15 kHz can be measured using this function type. The result of the frequency measurement is transferred to the com unit as an integer with a degree of accuracy of 0.1 %. New measured results are available in the com unit every 100 ms to 1000 ms (1 Hz) (every 10 seconds at 0.1 Hz) depending on the frequency. The frequency measurement operates with the internal 16 MHz quartz to measure the time between 2 pulses. The shortest pulse is 20 μs.

Counter Input

The module operates in the same way as a 12-bit counter input and records counter values up to 4095 (corresponds to 12 out of 16 bits), whereby the first 4 bits contain status information. In the same way as a 32-bit counter input, the I/O module uses a 4-byte counter in the com unit that records counter values up to 4294967295 (2^{32}).

A counter quotient can be applied to the counter inputs to prevent them from reaching the maximum counter reading (overflow) before the next bus query when the counting frequencies are high. When a counter input and frequency input are combined, the counter quotient is not available.

Combination of Counter Input and Frequency Input

When a counter input and frequency input are combined, the minimum pulse time/pulse pause is 10 ms. The maximum detectable frequency is then 50 Hz.

Frequency Input up to 400 Hz

A version of the I/O module is available with a maximum frequency of 400 Hz for sensors with bouncing contacts. Even if all functions of the 15 kHz version can be selected in the configuration software, a software package enables the suppression of pulses with a duration of < 1 ms. In spite of this, the 400 Hz version is treated in the same way as the 15 kHz version.

If the start of range setting is > 0 Hz, check whether the following formula produces a result of less than 400.

End of range / (1 - start of range / end of range)

The interrupt control prevents higher values from being processed.



Note!

32-Bit Counter Values

32-bit counter values are stored in the com unit. The counter values are deleted when removing a com unit, in the event of a power failure, when disconnecting the power supply, and in the case of a redundancy switchover.

12-bit counter values are accurate at all times because they are stored in the actual I/O module. The process control system must add up the difference between two successive queries in order to calculate the 12-bit counter total. When adding up the values after a counter overflow, make sure that the current counter value is less than the previous one. Values are usually counted at relatively low frequencies. The master is therefore in a position to retrieve counter values so regularly that a maximum of 1 counter overflow between 2 queries can be expected.



Note!

The bus cycle time is 500 ms and the value counted by the 12-bit counter is a maximum of 4095, resulting in a maximum frequency of $4095/0.5 \text{ sec} = 8190 \text{ Hz}$. If the bus cycle time does not match the counting frequency, the 32-bit counter can be used subject to restrictions in terms of redundancy switchover and disconnection from the power supply.

6.6.6 Direction Detection

The second input is used to determine the direction of rotation from the phase shift between the two incoming pulses.

If the direction detection has not been specified in the parameter settings, then the pulse count is incremented. If the direction detection has been specified in the parameter settings, the I/O module processes the field signals as follows:

- The counter increments the incoming pulses if the direction input is logic 0.
- The counter decrements the incoming pulses if the direction input is logic 1.

The master detects the counting direction of the 32-bit counter by comparing the count values of successive cycles. For the 12-bit counter, a direction bit is transmitted.

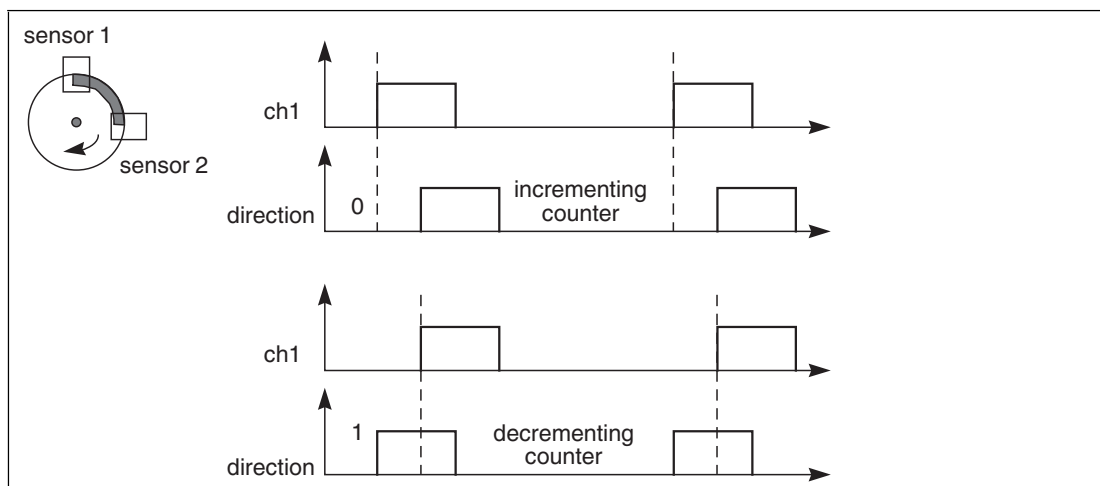

Figure 6.8 Direction detection

6.6.7 Editing Device Data

The parameters and DP configuration strings vary depending on function type.

All I/O module parameters that can be configured via the PROFIBUS class 1 master are listed below. See chapter 4

If the PROFIBUS class 1 master is not yet ready for operation, e.g., during partial commissioning, the remote I/O station can be configured with the help of the DTM and an external FDT framework application such as PACTware™. See chapter 5

If you are operating a master that has drivers or libraries, you do not need to worry about the octet strings. You only need to enter the relevant parameters.

All parameters are valid for each channel.

Function Type: Frequency Input

DP configuration string: 0x50

parameter string: 0x13, data_1, data_2

Data_1, Data_2

Bit	Parameter	Selection
Data_1		
0	Line fault detection	0 = off 1 = on
1	Direction detection	0 = off 1 = on
2 ... 3	Analog filter	0 = off 1 = 100 %/s 2 = 10 %/s 3 = 1 %/s
4 ... 5	-	-
6 ... 7	Function type	0 = frequency
Data_2		
0 ... 5	Measurement range	0 = 0 ... 15,000 Hz 1 = 0 ... 10,000 Hz 2 = 0 ... 5000 Hz 3 = 0 ... 2000 Hz 4 = 0 ... 1000 Hz 5 = 0 ... 500 Hz 6 = 0 ... 200 Hz 7 = 0 ... 100 Hz 8 = 0 ... 50 Hz 9 = 0 ... 20 Hz 10 = 0 ... 10 Hz 11 = 0 ... 5 Hz 12 = 0 ... 2 Hz 13 = 0 ... 1 Hz
6 ... 7	-	-

Function Type: 12 Bit Counter Input

DP configuration string: 0x50
parameter string: 0x13, data_1, data_2

Data_1, Data_2

Bit	Parameter	Selection
Data_1		
0	Line fault detection	0 = off 1 = on
1	Direction detection	0 = off 1 = on
2 ... 5	-	-
6 ... 7	Function type	2 = 12 bit counter input
Data_2		
0 ... 3	Counter quotient	0 = 1 1 = 10 2 = 100 3 = 1000 4 = 10,000
4 ... 7	-	-

Function Type: 32 Bit Counter Input

DP configuration string: 0x51
parameter string: 0x13, data_1, data_2

Data_1, Data_2

Bit	Parameter	Selection
Data_1		
0	Line fault detection	0 = off 1 = on
1	Direction detection	0 = off 1 = on
2 ... 5	-	-
6 ... 7	Function type	1 = 32 bit counter input
Data_2		
0 ... 3	Counter quotient	0 = 1 1 = 10 2 = 100 3 = 1000 4 = 10,000
4 ... 7	-	-

Function Type: Combined 32 Bit Counter and Frequency Input

DP configuration string: 0x52
parameter string: 0x13, data_1, data_2

Data_1, Data_2

Bit	Parameter	Selection
Data_1		
0	Line fault detection	0 = off 1 = on
1	Direction detection	0 = off 1 = on
2 ... 5	-	-
6 ... 7	Function type	3 = frequency measurement+counter
Data_2		
0 ... 3	Measurement range	0 = 0 ... 50 Hz 1 = 0 ... 20 Hz 2 = 0 ... 10 Hz 3 = 0 ... 5 Hz 4 = 0 ... 2 Hz 5 = 0 ... 1 Hz
4 ... 7	-	-

Line fault detection

For NAMUR proximity switches, the line fault detection can detect line breakages or short circuits. The connection at the field end cannot be monitored for contact inputs without additional resistance circuitry.

Direction detection

The direction detection input can be used either to count up or down or as a status indicator for the direction of rotation.

Analog filter

The analog filter for damping the signal can be activated if the input signals fluctuate. The value defines the rate of change of the input value in % per second. On the slowest setting of 1 %/s, it takes 90 seconds for a 90 % modification of the input signal to pass through the filter completely. The measurement range is used as the reference value (characteristic: ramp, linear).

Counter quotient

This parameter determines how frequently the pulse is counted. For example, if you enter 2, every 100th pulse is counted.

Preferred Parameter Values

Parameter	Preferred value
Function type: Frequency input up to 15 kHz	
Line fault detection	Off
Direction detection	Off
Analog filter	Off
Measurement range	0 Hz ... 15,000 Hz
Function type: 12/32 bit counter input	
Line fault detection	Off
Direction detection	Off
Counter quotient	1
Function type: Combined with 32 bit counter and frequency input up to 50 Hz	
Line fault detection	Off
Direction detection	Off
Measurement range	0 Hz ... 50 Hz

6.7 LB 1007 Digital Input

6.7.1 Description

Versions

LB1007, digital input, not intrinsically safe

Features

- Occupies 1 slot on the backplane
- Number of channels: 7
- Suitable sensors: mechanical contacts, NAMUR proximity switches, 2-wire initiators

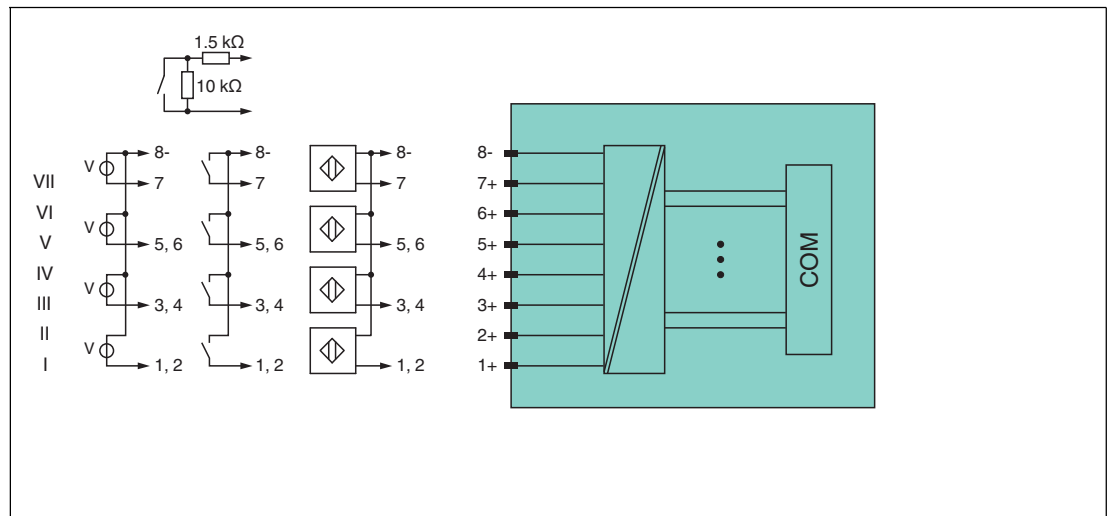

Figure 6.9 Block diagram LB1007

Refer to the corresponding data sheet and operating instructions for further information.

6.7.2 Measuring Time and Cycle Time

The maximum input frequency of the signals is 50 Hz. However, the measurability of the input statuses is dependent on the cycle time of the data traffic on the bus, e.g., only 1 Hz with a sampling time of 500 ms.

Adjust short signals to the sampling cycles of the process control system by extending the signals using the configurable off delay. The signals are transmitted to the com unit every 6.5 ms irrespective of the sampling interval of the process control system.

6.7.3 Data Transfer

Data is transferred as specified in the PROFIBUS specification.

Successful PROFIBUS communication requires that the configuration, in particular the DP configuration string, in the master and the remote I/O station are identical. The configuration parameters are stored in the GSD/GSE file.

If the GSD/GSE file can be incorporated into the master, the DP configuration code for the relevant I/O module is copied automatically. If the GSD/GSE file cannot be incorporated, the configuration parameters must be entered in accordance with the table in this chapter. In addition to the GSD/GSE file, there are drivers available for further integration into various masters. The drivers provide the signals for the remote I/O station in processed format, meaning a manual integration of the I/O data in the data structures of the master is unnecessary.

Bit Structure within the Data Telegram

DP configuration code 11		
Byte	Bit	Description
Input byte 1	0	Status channel 5
	1	Line fault detection channel 5 (0 = OK, 1 = error)
	2	Status channel 6
	3	Line fault detection channel 6 (0 = OK, 1 = error)
	4	Status channel 7
	5	Line fault detection channel 7 (0 = OK, 1 = error)
	6 ... 7	Empty
Input byte 2	0	Status channel 1
	1	Line fault detection channel 1 (0 = OK, 1 = error)
	2	Status channel 2
	3	Line fault detection channel 2 (0 = OK, 1 = error)
	4	Status channel 3
	5	Line fault detection channel 3 (0 = OK, 1 = error)
	6	Status channel 4
	7	Line fault detection channel 4 (0 = OK, 1 = error)
Output bytes		Without output bytes

6.7.4 Line Fault Detection

With NAMUR proximity switches, the line fault detection can detect a line breakage or short circuit and can be switched off on a channel-by-channel basis.

If you are using mechanical contacts, deactivate line fault detection or connect the mechanical contact at the installation location using an additional resistor circuit. Using the resistor circuit, the electronic circuit can distinguish between a closed switch and a short circuit. The resistor circuit is available as an accessory.

24 V and 5 V inputs can only be used when line fault detection is disabled.



Figure 6.10 Resistor network for line fault detection

6.7.5 Editing Device Data

All I/O module parameters that can be configured via the PROFIBUS class 1 master are listed below. See chapter 4

If the PROFIBUS class 1 master is not yet ready for operation, e.g., during partial commissioning, the remote I/O station can be configured with the help of the DTM and an external FDT framework application such as PACTware™. See chapter 5

If you are operating a master that has drivers or libraries, you do not need to worry about the octet strings. You only need to enter the relevant parameters.

All parameters are valid for each channel.

DP configuration string: 0x11

parameter string: 0x17, data_1, data_2, data_3

Data_1, data_2, data_3

Bit	Parameters	Selection
Data_1		
0	Line breakage detection channel 1	0 = off 1 = on
1	Line breakage detection channel 2	0 = off 1 = on
2	Line breakage detection channel 3	0 = off 1 = on
3	Line breakage detection channel 4	0 = off 1 = on
4	Line breakage detection channel 5	0 = off 1 = on
5	Line breakage detection channel 6	0 = off 1 = on
6	Line breakage detection channel 7	0 = off 1 = on
7	–	–
Data_2		
–	–	–
Data_3		
0	–	–
1	Inverter channel 1 ... 7	0 = off 1 = on
2 ... 3	Switch-on delay channel 1 ... 7	0 = off 1 = 10 ms 2 = 100 ms 3 = 1000 ms
4 ... 5	Switch-off delay channel 1 ... 7	0 = off 1 = 10 ms 2 = 100 ms 3 = 1000 ms
6 ... 7	Contact type	0 = NAMUR 1 = 24 V 2 = 5 V

Line fault detection

For NAMUR proximity switches, the line fault detection can detect line breakages or short circuits. The connection at the field end cannot be monitored for contact inputs without additional resistance circuitry.

Inverter

Choose between positive or negative logic for the digital signal.

ON delay

You can use the ON delay to filter out short pulses. Enter a value in ms to shorten a signal change from 0 to 1.



OFF delay

You can use the OFF delay to extend short pulses. Enter a value in ms to extend a signal change from 1 to 0.



Contact type

Shows the signal type, e.g., pulse, current, resistance, NAMUR, or 24 V, depending on the I/O module.

Preferred Parameter Values

Parameters	Values
Line fault detection	Off
Inverter	Off
ON delay	Off
OFF delay	Off
Contact type	NAMUR

6.8 LB1*08, FB1*08 Digital Input

6.8.1 Description

Versions

- LB1008, digital input, not intrinsically safe
- FB1308, digital input, increased safety terminals
- LB1108, digital input, intrinsically safe
- FB1208, digital input, intrinsically safe

Features

- Occupies 2 slots on the backplane
- Number of channels: 8
- Suitable sensors: mechanical contacts, NAMUR proximity switches
The FB1308 I/O module can read active inputs with 24 V or 5 VDC. This does not apply to I/O modules LB1008, LB1108, and FB1208.

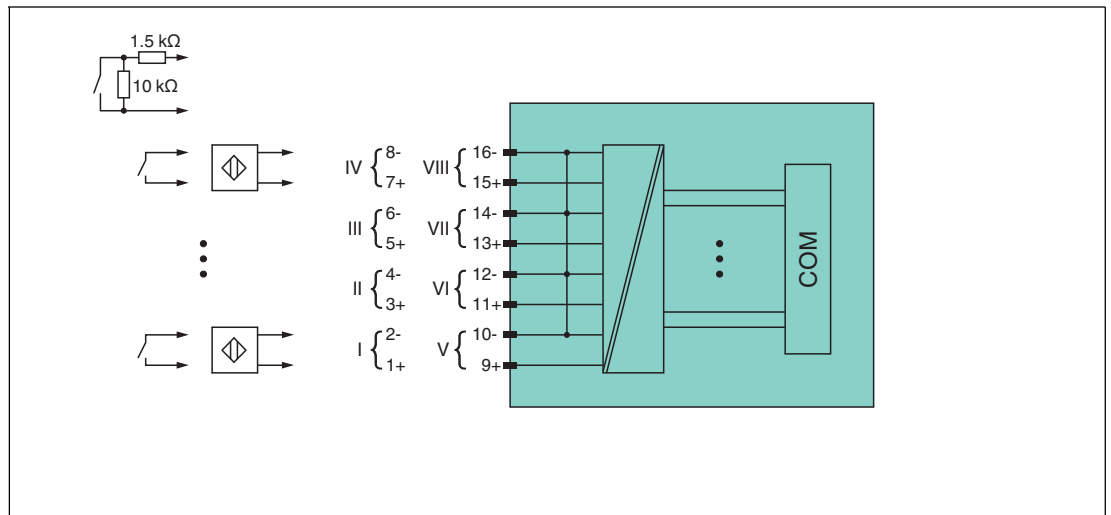

Figure 6.11 Block diagram: LB1*08, FB1208

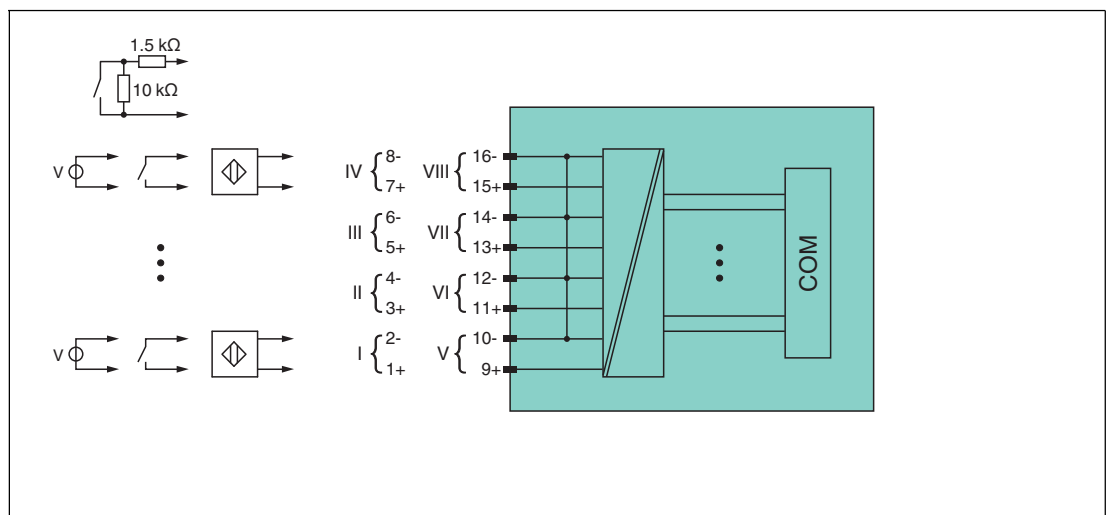

Figure 6.12 Block diagram: FB1308

Refer to the corresponding data sheet and operating instructions for further information.

6.8.2 Measuring Time and Cycle Time

The maximum input frequency of the signals is 50 Hz. However, the measurability of the input statuses is dependent on the cycle time of the data traffic on the bus, e.g., only 1 Hz with a sampling time of 500 ms.

Adjust short signals to the sampling cycles of the process control system by extending the signals using the configurable off delay. The signals are transmitted to the com unit every 6.5 ms irrespective of the sampling interval of the process control system.

6.8.3 Data Transfer

Data is transferred as specified in the PROFIBUS specification.

Successful PROFIBUS communication requires that the configuration, in particular the DP configuration string, in the master and the remote I/O station are identical. The configuration parameters are stored in the GSD/GSE file.

If the GSD/GSE file can be incorporated into the master, the DP configuration code for the relevant I/O module is copied automatically. If the GSD/GSE file cannot be incorporated, the configuration parameters must be entered in accordance with the table in this chapter. In addition to the GSD/GSE file, there are drivers available for further integration into various masters. The drivers provide the signals for the remote I/O station in processed format, meaning a manual integration of the I/O data in the data structures of the master is unnecessary.



Note!

Dual-Width I/O Module

Dual-width I/O modules occupy two slots. Therefore, always configure an empty slot after this I/O module unless it is the last I/O module in a Remote I/O station. See chapter 6.1

Bit Structure within the Data Telegram

DP configuration code 11		
Byte	Bit	Description
Input byte 1	0	Status channel 5
	1	Line fault detection channel 5 (0 = OK, 1 = error)
	2	Status channel 6
	3	Line fault detection channel 6 (0 = OK, 1 = error)
	4	Status channel 7
	5	Line fault detection channel 7 (0 = OK, 1 = error)
	6	Status channel 8
	7	Line fault detection channel 8 (0 = OK, 1 = error)
Input byte 2	0	Status channel 1
	1	Line fault detection channel 1 (0 = OK, 1 = error)
	2	Status channel 2
	3	Line fault detection channel 2 (0 = OK, 1 = error)
	4	Status channel 3
	5	Line fault detection channel 3 (0 = OK, 1 = error)
	6	Status channel 4
	7	Line fault detection channel 4 (0 = OK, 1 = error)
Output bytes		Without output bytes

200337 2016-03

6.8.4 Line Fault Detection

With NAMUR proximity switches, the line fault detection can detect a line breakage or short circuit and can be switched off on a channel-by-channel basis.

If you are using mechanical contacts, deactivate line fault detection or connect the mechanical contact at the installation location using an additional resistor circuit. Using the resistor circuit, the electronic circuit can distinguish between a closed switch and a short circuit. The resistor circuit is available as an accessory.

24 V and 5 V inputs can only be used when line fault detection is disabled.



Figure 6.13 Resistor network for line fault detection

6.8.5 Editing Device Data

All I/O module parameters that can be configured via the PROFIBUS class 1 master are listed below. See chapter 4

If the PROFIBUS class 1 master is not yet ready for operation, e.g., during partial commissioning, the remote I/O station can be configured with the help of the DTM and an external FDT framework application such as PACTware™. See chapter 5

If you are operating a master that has drivers or libraries, you do not need to worry about the octet strings. You only need to enter the relevant parameters.

All parameters are valid for each channel.

DP configuration string: 0x11

parameter string: 0x18, data_1, data_2, ..., data_8

Data_1 ... Data_8 (Channel 1 ... Channel 8)

Bit	Parameter	Selection
0	Line fault detection	0 = off 1 = on
1	Inverter	0 = off 1 = on
2 ... 3	ON delay	0 = off 1 = 10 ms 2 = 100 ms 3 = 1000 ms
4 ... 5	OFF delay	0 = off 1 = 10 ms 2 = 100 ms 3 = 1000 ms
6 ... 7	Contact type	0 = NAMUR 1 = 24 V (for FB1308 only) 2 = 5 V (for FB1308 only)

Line fault detection

For NAMUR proximity switches, the line fault detection can detect line breakages or short circuits. The connection at the field end cannot be monitored for contact inputs without additional resistance circuitry.

Inverter

Choose between positive or negative logic for the digital signal.

ON delay

You can use the ON delay to filter out short pulses. Enter a value in ms to shorten a signal change from 0 to 1.



OFF delay

You can use the OFF delay to extend short pulses. Enter a value in ms to extend a signal change from 1 to 0.



Contact type

Shows the signal type, e.g., pulse, current, resistance, NAMUR, or 24 V, depending on the I/O module.



Note!

Use the settings 1 (24 V) and 2 (5 V) only in conjunction with the I/O module FB1308A. The I/O modules LB1008, LB1108, and FB1208 are not approved for this contact type.

Preferred Parameter Values

Parameters	Values
Line fault detection	Off
Inverter	Off
ON delay	Off
OFF delay	Off
Contact type	NAMUR

6.9 LB1*09, FB1*09 Digital Input

6.9.1 Description

Versions

- LB1009, digital input, not intrinsically safe
- LB1109, digital input, intrinsically safe
- FB1209, digital input, intrinsically safe

Features

- Occupies 1 slot on the backplane
- Number of channels: 8
- Suitable sensors: mechanical contacts, NAMUR proximity switches
The LB1009 I/O module can also read active inputs with 24 V or 5 VDC. This does not apply to I/O modules LB1109, LB1109, and FB1209.



Note!

By default the LB1*09, FB1*09 digital input only supports mechanical contacts and NAMUR proximity switches. Activate the **Support for active input signals (5 V/24 VDC) for 1x09** option in the firmware-dependent com unit settings to be able to process active signals from 2-wire-initiators.

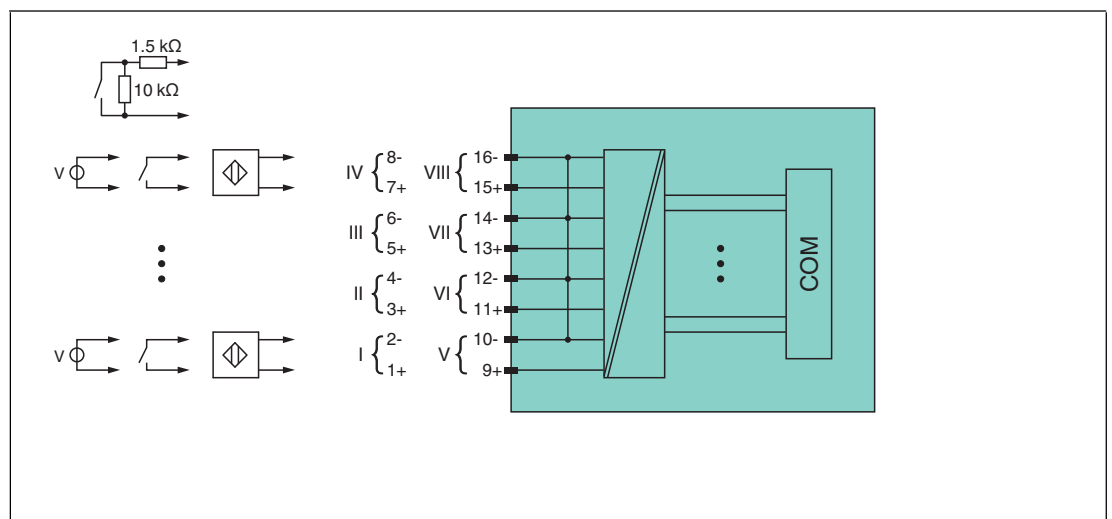

Figure 6.14 Block diagram LB1009

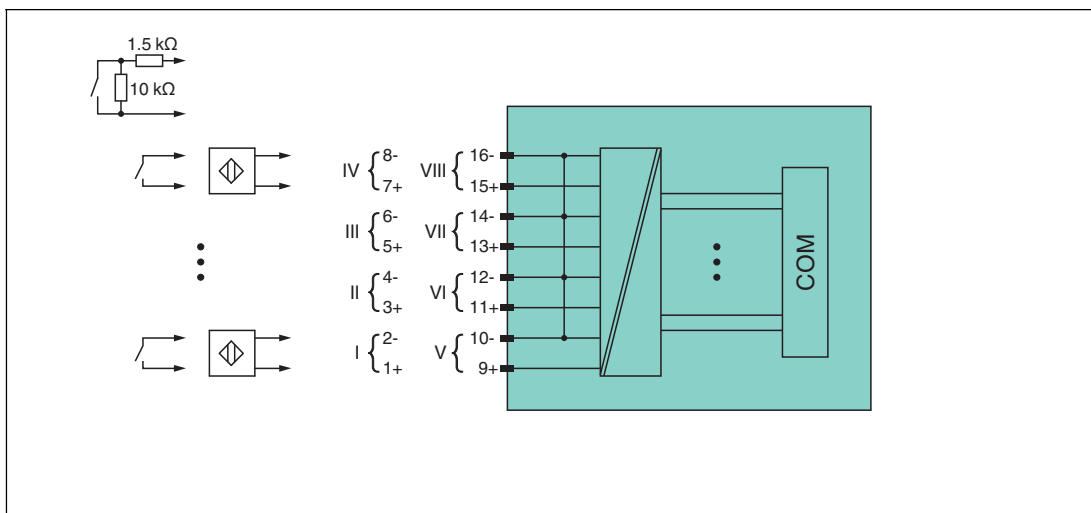

Figure 6.15 Block diagram LB1109, FB1209

Refer to the corresponding data sheet and operating instructions for further information.

6.9.2 Measuring Time and Cycle Time

The maximum input frequency of the signals is 50 Hz. However, the measurability of the input statuses is dependent on the cycle time of the data traffic on the bus, e.g., only 1 Hz with a sampling time of 500 ms.

Adjust short signals to the sampling cycles of the process control system by extending the signals using the configurable off delay. The signals are transmitted to the com unit every 6.5 ms irrespective of the sampling interval of the process control system.

6.9.3 Data Transfer

Data is transferred as specified in the PROFIBUS specification.

Successful PROFIBUS communication requires that the configuration, in particular the DP configuration string, in the master and the remote I/O station are identical. The configuration parameters are stored in the GSD/GSE file.

If the GSD/GSE file can be incorporated into the master, the DP configuration code for the relevant I/O module is copied automatically. If the GSD/GSE file cannot be incorporated, the configuration parameters must be entered in accordance with the table in this chapter. In addition to the GSD/GSE file, there are drivers available for further integration into various masters. The drivers provide the signals for the remote I/O station in processed format, meaning a manual integration of the I/O data in the data structures of the master is unnecessary.

Bit Structure within the Data Telegram

DP configuration code 11		
Byte	Bit	Description
Input byte 1	0	Status channel 5
	1	Line fault detection channel 5 (0 = OK, 1 = error)
	2	Status channel 6
	3	Line fault detection channel 6 (0 = OK, 1 = error)
	4	Status channel 7
	5	Line fault detection channel 7 (0 = OK, 1 = error)
	6	Status channel 8
	7	Line fault detection channel 8 (0 = OK, 1 = error)
Input byte 2	0	Status channel 1
	1	Line fault detection channel 1 (0 = OK, 1 = error)
	2	Status channel 2
	3	Line fault detection channel 2 (0 = OK, 1 = error)
	4	Status channel 3
	5	Line fault detection channel 3 (0 = OK, 1 = error)
	6	Status channel 4
	7	Line fault detection channel 4 (0 = OK, 1 = error)
Output bytes		Without output bytes

6.9.4 Line Fault Detection

With NAMUR proximity switches, the line fault detection can detect a line breakage or short circuit and can be switched off on a channel-by-channel basis.

If you are using mechanical contacts, deactivate line fault detection or connect the mechanical contact at the installation location using an additional resistor circuit. Using the resistor circuit, the electronic circuit can distinguish between a closed switch and a short circuit. The resistor circuit is available as an accessory.

24 V and 5 V inputs can only be used when line fault detection is disabled.



Figure 6.16 Resistor network for line fault detection

6.9.5 Editing Device Data

All I/O module parameters that can be configured via the PROFIBUS class 1 master are listed below. See chapter 4

If the PROFIBUS class 1 master is not yet ready for operation, e.g., during partial commissioning, the remote I/O station can be configured with the help of the DTM and an external FDT framework application such as PACTware™. See chapter 5

If you are operating a master that has drivers or libraries, you do not need to worry about the octet strings. You only need to enter the relevant parameters.

All parameters are valid for each channel.

DP configuration string: 0x11

parameter string: 0x19, data_1, data_2, data_3

Data_1, data_2, data_3

Bit	Parameters	Selection
Data_1		
0 ... 7	Line fault detection channel 1 ... 8	0 = off 1 = on
Data_2		
0	Inverter channel 1 ... 4	0 = off 1 = on
1	–	–
2 ... 3	Contact type channel 1 ... 4	0 = NAMUR 1 = 24 V 2 = 5 V
4 ... 5	Switch-on delay channel 1 ... 4	0 = off 1 = 10 ms 2 = 100 ms 3 = 1000 ms
6 ... 7	Switch-off delay channel 1 ... 4	= off 1 = 10 ms 2 = 100 ms 3 = 1000 ms
Data_3		
0	Inverter channel 5 ... 8	0 = off 1 = on
1	–	–
2 ... 3	Contact type channel 5 ... 8	0 = NAMUR 1 = 24 V 2 = 5 V
4 ... 5	Switch-on delay channel 5 ... 8	0 = off 1 = 10 ms 2 = 100 ms 3 = 1000 ms
6 ... 7	Switch-off delay channel 5 ... 8	0 = off 1 = 10 ms 2 = 100 ms 3 = 1000 ms

Line fault detection

For NAMUR proximity switches, the line fault detection can detect line breakages or short circuits. The connection at the field end cannot be monitored for contact inputs without additional resistance circuitry.

Inverter

Choose between positive or negative logic for the digital signal.

Contact type

Shows the signal type, e.g., pulse, current, resistance, NAMUR, or 24 V, depending on the I/O module.



Note!

Use the settings 1 (24 V) and 2 (5 V) only in conjunction with the I/O module LB1009A. The I/O modules LB1109 and FB1209 are not approved for this contact type.

ON delay

You can use the ON delay to filter out short pulses. Enter a value in ms to shorten a signal change from 0 to 1.



OFF delay

You can use the OFF delay to extend short pulses. Enter a value in ms to extend a signal change from 1 to 0.

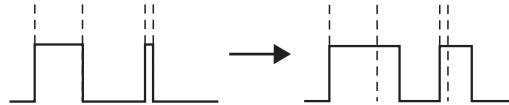

Preferred Parameter Values

Parameters	Values
Line fault detection	Off
Inverter	Off
Contact type	NAMUR
ON delay	Off
OFF delay	Off

6.10 LB1014, LB1015 Digital Input

6.10.1 Description

Versions

- LB1014, digital input, not intrinsically safe
- LB1015, digital input, not intrinsically safe

Features

- Occupies 2 slots on the backplane
- Number of channels: 15
- Digital signals
 - LB1014: AC 95 V ... 230 V (250 V max.) in phase
 - LB1015: DC 24 V (30 V max.)

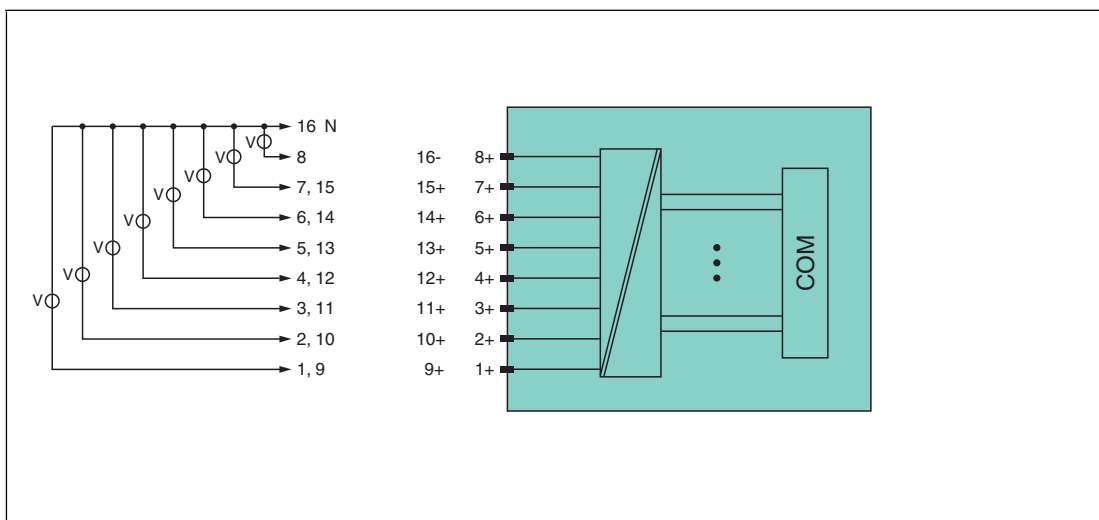

Figure 6.17 Block diagram LB1014, LB1015

Refer to the corresponding data sheet and operating instructions for further information.

6.10.2 Measuring Time and Cycle Time

The maximum input frequency of the signals is 50 Hz. However, the scope to measure this frequency depends on the cycle time of the data traffic on the bus, e.g., only 1 Hz with a sampling time of 500 ms.

The signals are transmitted to the com unit every 6.5 ms irrespective of the sampling interval of the process control system.

6.10.3 Data Transfer

Data is transferred as specified in the PROFIBUS specification.

Successful PROFIBUS communication requires that the configuration, in particular the DP configuration string, in the master and the remote I/O station are identical. The configuration parameters are stored in the GSD/GSE file.

If the GSD/GSE file can be incorporated into the master, the DP configuration code for the relevant I/O module is copied automatically. If the GSD/GSE file cannot be incorporated, the configuration parameters must be entered in accordance with the table in this chapter. In addition to the GSD/GSE file, there are drivers available for further integration into various masters. The drivers provide the signals for the remote I/O station in processed format, meaning a manual integration of the I/O data in the data structures of the master is unnecessary.



Note!

Dual-Width I/O Module

Dual-width I/O modules occupy two slots. Therefore, always configure an empty slot after this I/O module unless it is the last I/O module in a Remote I/O station. See chapter 6.1

Bit Structure within the Data Telegram

DP configuration code 11		
Byte	Bit	Description
Input byte 1	0	Status channel 9
	1	Status channel 10
	2	Status channel 11
	3	Status channel 12
	4	Status channel 13
	5	Status channel 14
	6	Status channel 15
	7	Collective error message, channels 1 ... 15
Input byte 2	0	Status channel 1
	1	Status channel 2
	2	Status channel 3
	3	Status channel 4
	4	Status channel 5
	5	Status channel 6
	6	Status channel 7
	7	Status channel 8
Output bytes		Without output bytes

6.10.4 Line Fault Detection

The I/O module does not provide any line fault detection function.

6.10.5 Editing Device Data

All I/O module parameters that can be configured via the PROFIBUS class 1 master are listed below. See chapter 4

If the PROFIBUS class 1 master is not yet ready for operation, e.g., during partial commissioning, the remote I/O station can be configured with the help of the DTM and an external FDT framework application such as PACTware™. See chapter 5

If you are operating a master that has drivers or libraries, you do not need to worry about the octet strings. You only need to enter the relevant parameters.

All parameters are valid for each channel.

DP configuration string: 0x11
parameter string LB 1014: 0x1E, data_1, data_2
parameter string LB 1015: 0x1F, data_1, data_2

Data_1, data_2

Bit	Parameters	Selection
Data_1		
0	Inverter channel 1	0 = off 1 = on
1	Inverter channel 2	0 = off 1 = on
2	Inverter channel 3	0 = off 1 = on
3	Inverter channel 4	0 = off 1 = on
4	Inverter channel 5	0 = off 1 = on
5	Inverter channel 6	0 = off 1 = on
6	Inverter channel 7	0 = off 1 = on
7	Inverter channel 8	0 = off 1 = on
Data_2		
0	Inverter channel 9	0 = off 1 = on
1	Inverter channel 10	0 = off 1 = on
2	Inverter channel 11	0 = off 1 = on
3	Inverter channel 12	0 = off 1 = on
4	Inverter channel 13	0 = off 1 = on
5	Inverter channel 14	0 = off 1 = on
6	Inverter channel 15	0 = off 1 = on
7	–	–

Inverter

Choose between positive or negative logic for the digital signal.

Preferred Parameter Values

Parameters	Values
Inverter	Off

6.11 LB20*, LB21*, FB22* Digital Output with Position Feedback

6.11.1 Description

Versions

- LB20*, digital output with position feedback, non-intrinsically safe
Versions available with bus-independent shutdown input
- LB21*, digital input with position feedback, intrinsically safe
Versions available with bus-independent shutdown input
- FB22*, digital input with position feedback, intrinsically safe
Versions available with bus-independent shutdown input

Features

- Occupies 1 slot on the backplane
- Number of channels
 - 1 output channel
 - 2 input channels, e.g., for position feedback

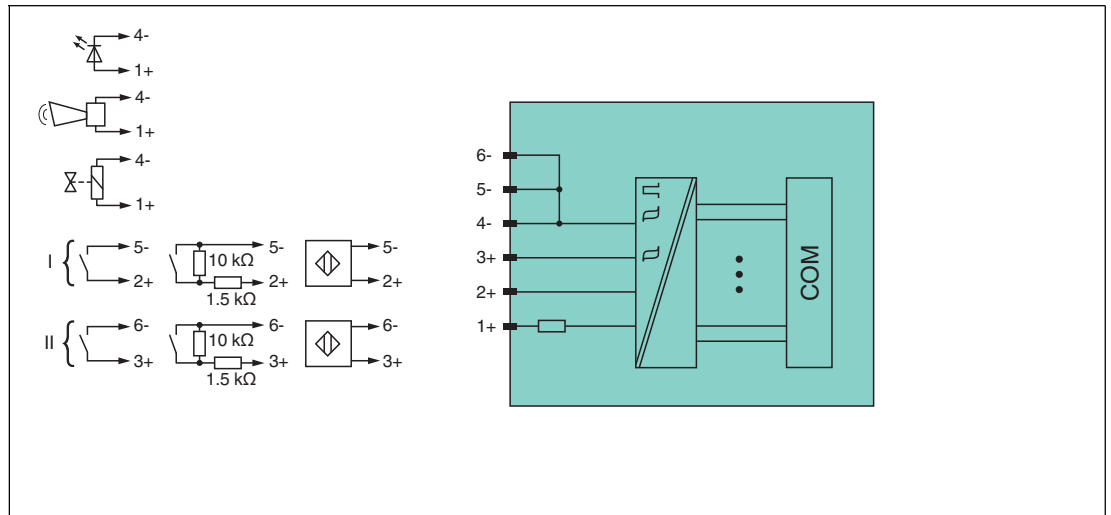

Figure 6.18 Block diagram: LB2002, LB2101 ... LB2113, FB22* without shutdown input

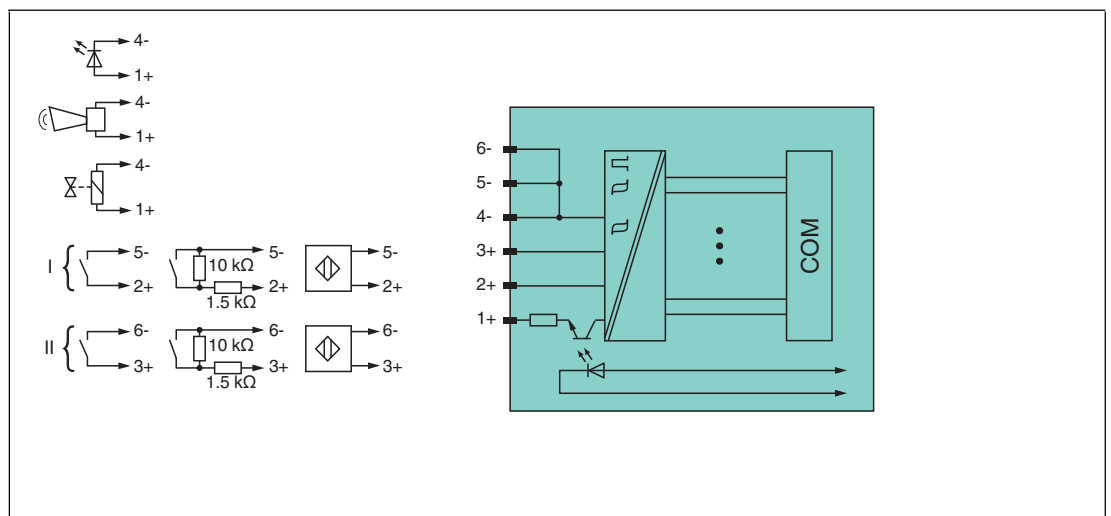

Figure 6.19 Block diagram: LB2101 ... LB2113, FB22* with shutdown input

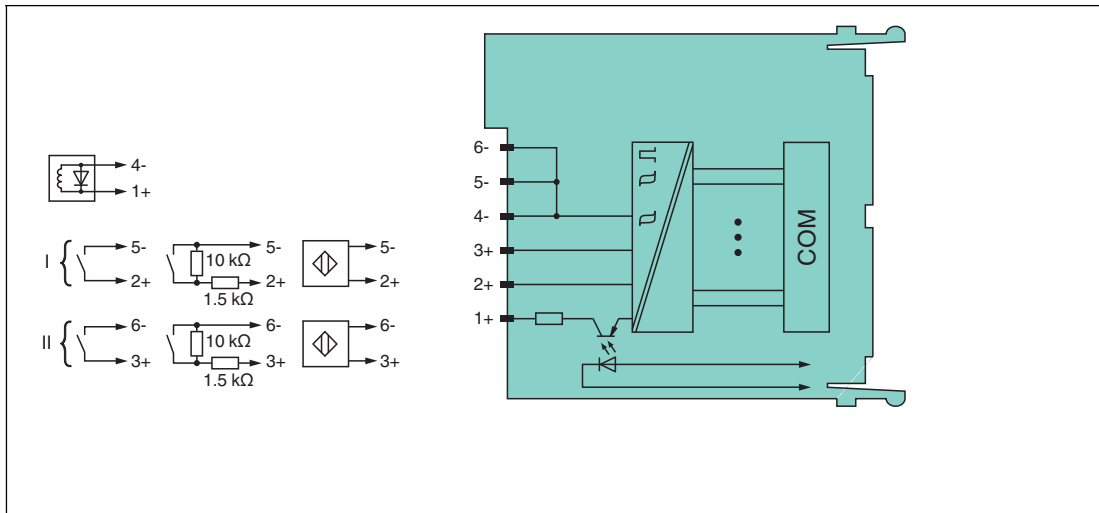

Figure 6.20 Block diagram: LB2*16, FB2216, LB2*17, FB2217 with shutdown input

Refer to the corresponding data sheet and operating instructions for further information.

6.11.2 Measuring Time and Cycle Time

The maximum input frequency of the signals is 50 Hz. However, the measurability of the input statuses is dependent on the cycle time of the data traffic on the bus, e.g., only 1 Hz with a sampling time of 500 ms.

Adjust short signals to the sampling cycles of the process control system by extending the signals using the configurable off delay. The signals are transmitted to the com unit every 6.5 ms irrespective of the sampling interval of the process control system.

6.11.3 Data Transfer

Data is transferred as specified in the PROFIBUS specification.

Successful PROFIBUS communication requires that the configuration, in particular the DP configuration string, in the master and the remote I/O station are identical. The configuration parameters are stored in the GSD/GSE file.

If the GSD/GSE file can be incorporated into the master, the DP configuration code for the relevant I/O module is copied automatically. If the GSD/GSE file cannot be incorporated, the configuration parameters must be entered in accordance with the table in this chapter. In addition to the GSD/GSE file, there are drivers available for further integration into various masters. The drivers provide the signals for the remote I/O station in processed format, meaning a manual integration of the I/O data in the data structures of the master is unnecessary.

Bit Structure within the Data Telegram

DP configuration code 30		
Byte	Bit	Description
Input byte 1	0	Status channel 1 (valve output)
	1	Line fault detection channel 1 (0 = OK, 1 = error)
	2	Status channel 2 (acknowledgment input 1)
	3	Line fault detection channel 2 (0 = OK, 1 = error)
	4	Status channel 3 (acknowledgment input 2)
	5	Line fault detection channel 3 (0 = OK, 1 = error)
	6 ... 7	Empty
Output byte 1	0	Output value channel 1 (valve output)
	1	"Invalid" identifier channel 1 (0 = OK, 1 = invalid)
	2 ... 7	Empty

6.11.4 Line Fault Detection

With NAMUR proximity switches, the line fault detection can detect a line breakage or short circuit and can be switched off on a channel-by-channel basis.

If you are using mechanical contacts, deactivate line fault detection or connect the mechanical contact at the installation location using an additional resistor circuit. Using the resistor circuit, the electronic circuit can distinguish between a closed switch and a short circuit. The resistor circuit is available as an accessory.

The valve control circuit is monitored by a current pulse. This current pulse is brief enough not to operate a connected valve. If the I/O module is being used with indicator lights or acoustic sensors, you can switch off the current pulse for each channel.

It is not always possible to monitor the valve circuit when booster valves are used because these valves have a storage capacitor that behaves like a short circuit when the valve is switched off. In such cases, depending on the valve, a 10 kΩ parallel resistor enables line fault detection for booster valves. If line fault detection is still detected when the valve is off, even with the parallel resistor connected, disable the line fault detection function.



Figure 6.21 Resistor network for line fault detection

6.11.5 Watchdog

The I/O module has a watchdog function. If the communication between the I/O module and com unit stops, the I/O module enters the safe state after 0.5 s.

6.11.6 Editing Device Data

All I/O module parameters that can be configured via the PROFIBUS class 1 master are listed below. See chapter 4

If the PROFIBUS class 1 master is not yet ready for operation, e.g., during partial commissioning, the remote I/O station can be configured with the help of the DTM and an external FDT framework application such as PACTware™. See chapter 5

If you are operating a master that has drivers or libraries, you do not need to worry about the octet strings. You only need to enter the relevant parameters.

All parameters are valid for each channel.

DP configuration string: 0x30

parameter string for LB2002, LB2101 ... LB2113, FB2201 ... FB2213: Type, data_1, data_2, data_3

parameter string for LB2*16, FB2216, LB2*17, FB2217: Data_1, data_2, data_3

Type, Data_1, Data_2, Data_3

Bit	Parameter	Selection
Type Applies only to LB2002, LB2101 ... LB2113, FB2201 ... FB2213. With LB2*16, FB2216, LB2*17, FB2217, the type is set automatically by the module selection.		
0 ... 3	Valve driver type	01 = type 1 (22 V/315 Ω) 02 = type 2 (24 V/210 Ω) 03 = type 3 (24 V/360 Ω) 04 = type 4 (22 V/220 Ω) 05 = type 5 (22.8 V/290 Ω) 06 = type 6 (16.5 V/115 Ω) 07 = type 7 (16.5 V/170 Ω) 08 = type 8 (14 V/122 Ω) 12 = type 12 (25.3 V/329 Ω) 13 = type 13 (26.7 V/509 Ω)
4 ... 7	-	-
Data_1 (output)		
0	Line fault detection	0 = off 1 = on
1	Inverter	0 = off 1 = on
2 ... 3	Substitute value	0 = logical 0 1 = logical 1 2 = last valid value 3 = current value
4 ... 7	-	-
Data_2 (input 1)/data_3 (input 2)		
0	Line fault detection	0 = off 1 = on
1	Inverter	0 = off 1 = on
2 ... 3	ON delay	0 = off 1 = 10 ms 2 = 100 ms 3 = 1000 ms
4 ... 5	OFF delay	0 = off 1 = 10 ms 2 = 100 ms 3 = 1000 ms
6 ... 7	-	-

Line fault detection

For NAMUR proximity switches, the line fault detection can detect line breakages or short circuits. The connection at the field end cannot be monitored for contact inputs without additional resistance circuitry.

Inverter

Choose between positive or negative logic for the digital signal.

Substitute value

The I/O module may issue substitute values in the event of an error. See chapter 6.2

ON delay

You can use the ON delay to filter out short pulses. Enter a value in ms to shorten a signal change from 0 to 1.

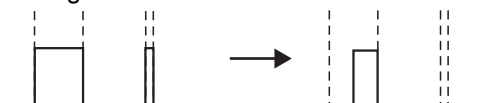

OFF delay

You can use the OFF delay to extend short pulses. Enter a value in ms to extend a signal change from 1 to 0.

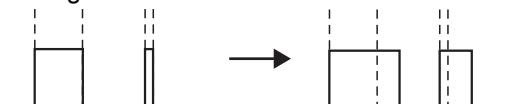

Preferred Parameter Values

Parameter	Values
Output	
Output driver type Applies only to LB2002, LB2101 ... LB2113, FB2201 ... FB2213. With LB2*16, FB2216, LB2*17, FB2217, the type is set automatically by the module selection.	e.g., type 1 (22 V/315 Ω)
Line fault detection	Off
Inverter	Off
Substitute value	Off
Inputs	
Line fault detection	Off
Inverter	Off
ON delay	Off
OFF delay	Off

6.12 LB3101, FB3201 Transmitter Power Supply, Current Input

6.12.1 Description

Versions

- LB3101, transmitter power supply, current input, intrinsically safe
- FB3201, transmitter power supply, current input, intrinsically safe

Features

- Occupies 1 slot on the backplane
- Number of channels: 1
- Suitable field devices: pressure, differential pressure, filling level, flow rate, and temperature converters, etc.

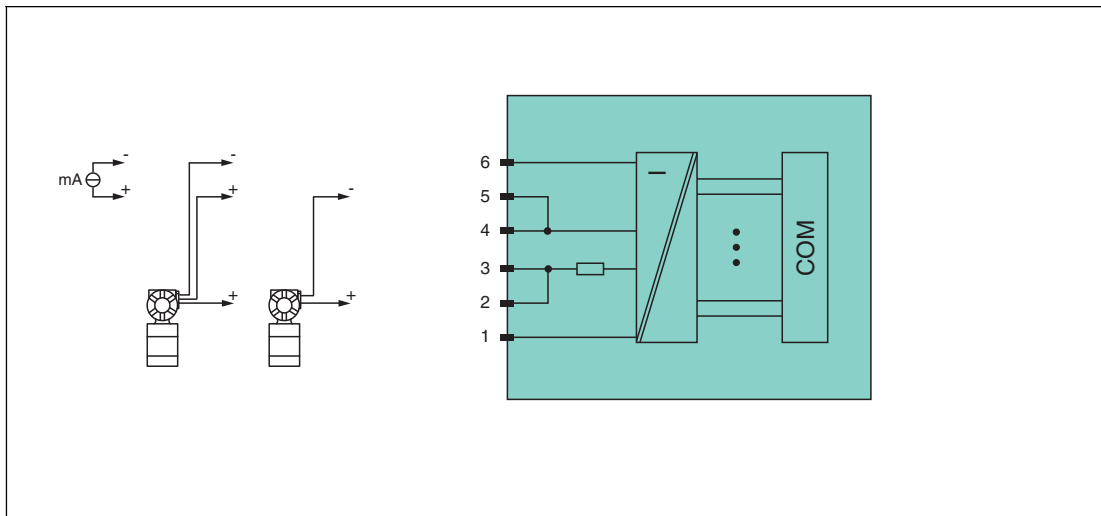

Figure 6.22 Block diagram LB3101, FB3201

2-wire transmitter

Supply circuit: 2/3+, 4/5-

3-wire transmitter

Supply circuit: 2/3+, 6-

Measuring circuit: 4/5+, 6-

4-wire transmitter (powered externally)

Measuring circuit: 4/5+, 6-

Input resistance at terminals 5 and 6: 15 Ω

Refer to the corresponding data sheet and operating instructions for further information.

6.12.2 Resolution

Input signals within a range of 0 mA ... 25 mA are detected with a resolution of 12 bits. The actual measuring range is calculated based on this resolution.

For the range between 4 mA ... 20 mA (corresponds to 0 % ... 100 %), a resolution of 2500 measurement points is obtained, which corresponds to 0.04 %. Underranges and overranges are taken into consideration.

6.12.3 Measuring Time and Cycle Time

The conversion time is approx. 100 ms. The accuracy of the measured value depends on the cycle time of the data traffic on the bus. The signals are transmitted to the com unit every 6.5 ms irrespective of the measuring time.

6.12.4 Data Transfer

Data is transferred as specified in the PROFIBUS specification.

Successful PROFIBUS communication requires that the configuration, in particular the DP configuration string, in the master and the remote I/O station are identical. The configuration parameters are stored in the GSD/GSE file.

If the GSD/GSE file can be incorporated into the master, the DP configuration code for the relevant I/O module is copied automatically. If the GSD/GSE file cannot be incorporated, the configuration parameters must be entered in accordance with the table in this chapter. In addition to the GSD/GSE file, there are drivers available for further integration into various masters. The drivers provide the signals for the remote I/O station in processed format, meaning a manual integration of the I/O data in the data structures of the master is unnecessary.

The process data for each channel is transferred in unsigned integers within a range from 0 ... 65,535.

A data word (=16 bit) is available for each channel for the data transfer. The least significant 4 bits are of little importance for the accuracy of the measured value and are therefore used for transferring status information.

Bit Structure within the Data Telegram

DP configuration code 50		
Byte	Bit	Description
Input byte 1 (low byte)	0	Live zero if current \leq 3.6 mA (*)
	1	Line fault detection channel 1 (0 = OK, 1 = error)
	2 ... 3	Empty
	4 ... 7	Measured value (12 bit)
Input byte 2 (high byte)	0 ... 7	
Output bytes		Without output bytes
(*) The live zero monitoring transmits an error bit (= 1) if the current falls below the minimum of 3.6 mA.		

6.12.5 Line Fault Detection

The line fault detection can detect a lead breakage or short circuit and can be switched off on a channel-by-channel basis.

You can preset the switching points at which a lead breakage or a short circuit is signaled, e.g., line breakage < 1 mA and short circuit > 21 mA.

The current circuit has Live Zero monitoring. If the current falls below the minimum of 3.6 mA, an error bit is set (= 1).

6.12.6 Editing Device Data

All I/O module parameters that can be configured via the PROFIBUS class 1 master are listed below. See chapter 4

If the PROFIBUS class 1 master is not yet ready for operation, e.g., during partial commissioning, the remote I/O station can be configured with the help of the DTM and an external FDT framework application such as PACTware™. See chapter 5

If you are operating a master that has drivers or libraries, you do not need to worry about the octet strings. You only need to enter the relevant parameters.

All parameters are valid for each channel.

DP configuration string: 0x50
parameter string: 0x31, data_1

Data_1

Bit	Parameters	Selection
0	Line fault detection	0 = off 1 = on
1	Operating mode	0 = 4 ... 20 mA (live zero) 1 = 0 ... 20 mA (dead zero)
2 ... 3	Analog filter	0 = off 1 = 100 %/s 2 = 10 %/s 3 = 1 %/s
4 ... 7	-	-

Line fault detection

Activate line fault detection to monitor the connection at the field end. In the event of a fault (e.g., lead breakage or short circuit), corresponding diagnostics are transmitted.

Operating mode

The **Operating mode** parameter defines the operating range of the I/O module with 0 ... 20 mA (Dead Zero) or 4 ... 20 mA (Live Zero).

Analog filter

The analog filter for damping the signal can be activated if the input signals fluctuate. The value defines the rate of change of the input value in % per second. On the slowest setting of 1 %/s, it takes 90 seconds for a 90 % modification of the input signal to pass through the filter completely. The measurement range is used as the reference value (characteristic: ramp, linear).

Preferred Parameter Values

Parameters	Values
Line fault detection	Off
Analog filter	Off
Operating mode	4 mA ... 20 mA

6.13 LB3*02, FB3*02, LB3103, FB3203 HART Transmitter Power Supply, current input

6.13.1 Description

Versions

- LB3002, HART transmitter power supply, current input, not intrinsically safe
- FB3302, HART transmitter power supply, current input, increased safety terminals
Terminals 3 and 4 are not passed through in this I/O module.
- LB3102, HART transmitter power supply, current input, intrinsically safe
- FB3202, HART transmitter power supply, current input, intrinsically safe
- LB3103, HART transmitter power supply, current input, intrinsically safe
- FB3203, HART transmitter power supply, current input, intrinsically safe

Features

- Occupies 1 slot on the backplane
- Number of channels: 1
- Suitable field devices: pressure, differential pressure, filling level, flow rate, and temperature converters, etc.

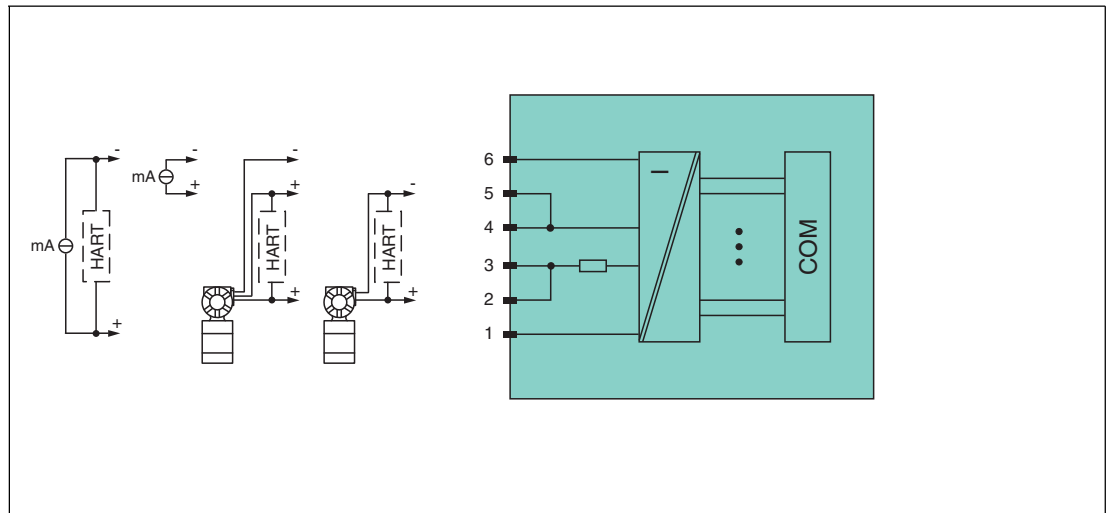

Figure 6.23 Block diagram LB3*02, LB3103, FB3*02, FB3203

2-wire transmitter (HART)

Supply circuit: 2/3+, 4/5-

3-wire transmitter (HART)

Supply circuit: 2/3+, 6-
Measuring circuit: 4/5+, 6-

4-wire transmitter (externally powered)

Measuring circuit: 4/5+, 6-
HART measuring circuit: 1+, 6-

Input resistance at terminals 5 and 6: 15 Ω

Input resistance at terminals 1 and 6 (HART): 236 Ω

Refer to the corresponding data sheet and operating instructions for further information.

6.13.2 Resolution

Input signals within a range of 0 mA ... 25 mA are detected with a resolution of 12 bits. The actual measuring range is calculated based on this resolution. For the range between 4 mA ... 20 mA (corresponds to 0 % ... 100 %), a resolution of 2500 measurement points is obtained, which corresponds to 0.04 %. Underranges and overranges are taken into consideration.

6.13.3 Measuring Time and Cycle Time

The conversion time is approx. 100 ms. The accuracy of the measured value depends on the cycle time of the data traffic on the bus. The signals are transmitted to the com unit every 6.5 ms irrespective of the measuring time.

6.13.4 Data Transfer

Data is transferred as specified in the PROFIBUS specification.

Successful PROFIBUS communication requires that the configuration, in particular the DP configuration string, in the master and the remote I/O station are identical. The configuration parameters are stored in the GSD/GSE file.

If the GSD/GSE file can be incorporated into the master, the DP configuration code for the relevant I/O module is copied automatically. If the GSD/GSE file cannot be incorporated, the configuration parameters must be entered in accordance with the table in this chapter. In addition to the GSD/GSE file, there are drivers available for further integration into various masters. The drivers provide the signals for the remote I/O station in processed format, meaning a manual integration of the I/O data in the data structures of the master is unnecessary.

The process data for each channel is transferred in unsigned integers within a range from 0 ... 65,535.

A data word (=16 bit) is available for each channel for the data transfer. The least significant 4 bits are of little importance for the accuracy of the measured value and are therefore used for transferring status information.

Bit Structure within the Data Telegram

DP configuration code 50		
Byte	Bit	Description
Input byte 1 (low byte)	0	Live zero if current \leq 3.6 mA (*)
	1	Line fault detection channel 1 (0 = OK, 1 = error)
	2 ... 3	Empty
	4 ... 7	Measured value (12 bit)
Input byte 2 (high byte)	0 ... 7	
Output bytes		Without output bytes
(*) The live zero monitoring transmits an error bit (= 1) if the current falls below the minimum of 3.6 mA.		

6.13.5 Line Fault Detection

The line fault detection can detect a lead breakage or short circuit and can be switched off on a channel-by-channel basis.

You can preset the switching points at which a lead breakage or a short circuit is signaled, e.g., line breakage < 1 mA and short circuit > 21 mA.

The current circuit has Live Zero monitoring. If the current falls below the minimum of 3.6 mA, an error bit is set (= 1).

6.13.6 Editing Device Data

All I/O module parameters that can be configured via the PROFIBUS class 1 master are listed below. See chapter 4

If the PROFIBUS class 1 master is not yet ready for operation, e.g., during partial commissioning, the remote I/O station can be configured with the help of the DTM and an external FDT framework application such as PACTware™. See chapter 5

If you are operating a master that has drivers or libraries, you do not need to worry about the octet strings. You only need to enter the relevant parameters.

All parameters are valid for each channel.



Caution!

Function interruption due to PROFIBUS restart

If you change the **Synchronous data** parameter and therefore change the number of HART auxiliary variables, this will result in a change to the data structure of the PROFIBUS data telegram. These modifications require a restart of the PROFIBUS.

You can change the number of HART auxiliary variables during ongoing operation only if your process control system supports Hot Configuration in Run (HCiR). See chapter 4.3.7

LB3*02, FB3*02

DP configuration string: depending on the number of HART variables
parameter string: 0x32, data_1

Data_1

Bit	Parameter	Selection
0	Line fault detection	0 = off 1 = on
1	Operating mode	0 = 4 ... 20 mA (live zero) 1 = 0 ... 20 mA (dead zero)
2 ... 3	Analog filter	0 = off 1 = 100 %/s 2 = 10 %/s 3 = 1 %/s
4 ... 6	Synchronous data	0 = standard 1 = standard + 1st HART variable 2 = standard + 1st ... 2nd HART variable 3 = standard + 1st ... 3rd HART variable 4 = standard + 1st ... 4th HART variable
7	-	-

Synchronous data

Each HART auxiliary variable occupies 4 octets in the synchronous data traffic. The I/O module, together with all four HART auxiliary variables, occupies a total of 18 octets within the synchronous data traffic. Thirteen of these I/O modules fill the entire data area. The HART auxiliary variables are updated less frequently than the standard process data.

The I/O module is allocated different DP configuration strings depending on how many HART auxiliary variables are included in the synchronous data traffic.

- **Standard:** In standard mode, 2 octets of data are provided.
DP configuration string: 0x50

- **Standard + 1st HART variable:** The first HART auxiliary variable is also provided (2 octets + 4 octets = 6 octets)
DP configuration string: 0x52
- **Standard + 1st + 2nd HART variables:** The first and second HART auxiliary variables are also provided (2 octets + 8 octets = 10 octets)
DP configuration string: 0x54
- **Standard + 1st to 3rd HART variables:** The first, second, and third HART auxiliary variables are also provided (2 octets + 12 octets = 14 octets)
DP configuration string: 0x56
- **Standard + 1st to 4th HART variables:** The first, second, third, and fourth HART auxiliary variables are also provided (2 octets + 16 octets = 18 octets)
DP configuration string: 0x58

If the remote I/O station receives a new parameter set, HART communication must be restarted. During the initialization phase, no valid HART auxiliary variables are available. Following initialization, the HART auxiliary variables are read by a HART scan and made available again. The scan generally takes several seconds.

LB3103, FB3203

DP configuration string: 0x50
parameter string: 0x33, data_1

Data_1

Bit	Parameter	Selection
0	Line fault detection	0 = off 1 = on
1	Operating mode	0 = 4 ... 20 mA (live zero) 1 = 0 ... 20 mA (dead zero)
2 ... 3	Analog filter	0 = off 1 = 100 %/s 2 = 10 %/s 3 = 1 %/s
4 ... 7	-	-

Line fault detection

Activate line fault detection to monitor the connection at the field end. In the event of a fault (e.g., lead breakage or short circuit), corresponding diagnostics are transmitted.

Operating mode

The **Operating mode** parameter defines the operating range of the I/O module with 0 ... 20 mA (Dead Zero) or 4 ... 20 mA (Live Zero).

Analog filter

The analog filter for damping the signal can be activated if the input signals fluctuate. The value defines the rate of change of the input value in % per second. On the slowest setting of 1 %/s, it takes 90 seconds for a 90 % modification of the input signal to pass through the filter completely. The measurement range is used as the reference value (characteristic: ramp, linear).

Preferred Parameter Values

Parameters	Values
Line fault detection	Off
Analog filter	Off
Operating mode	4 mA ... 20 mA

200337 2016-03

6.14 LB3104, FB3204 Transmitter Power Supply, Current Input
LB3*05, FB3*05 HART Transmitter Power Supply, Current Input

6.14.1 Description

Versions

- LB3104, transmitter power supply, current input, intrinsically safe
- FB3204, transmitter power supply, current input, intrinsically safe
- LB3005, HART transmitter power supply, current input, not intrinsically safe
- FB3305, HART transmitter power supply, current input, increased safety terminals
- LB3105, HART transmitter power supply, current input, intrinsically safe
- FB3205, HART transmitter power supply, current input, intrinsically safe

Features

- Occupies 2 slots on the backplane
- Number of channels: 4
- Suitable field devices: pressure, differential pressure, filling level, flow rate, and temperature converters, etc.

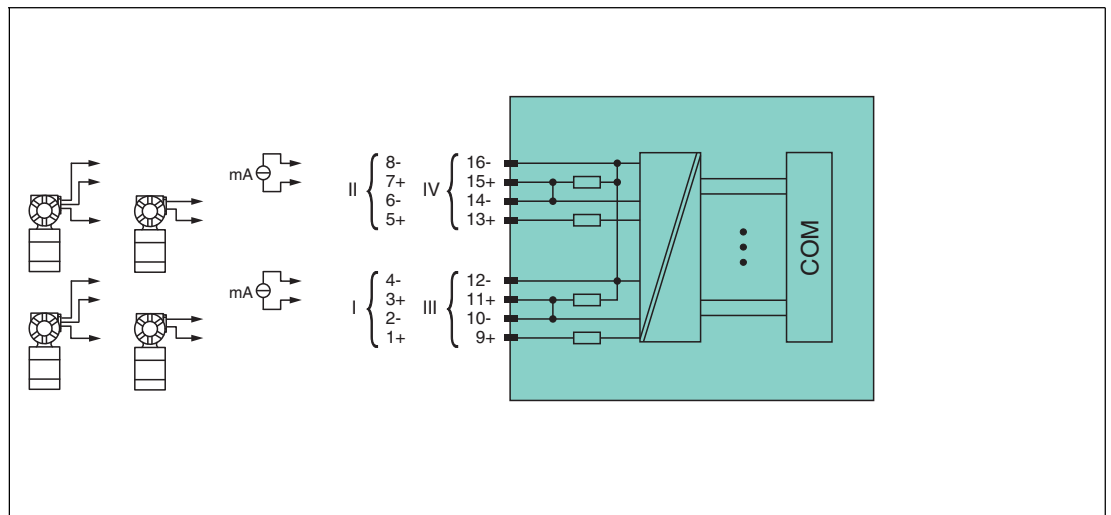

Figure 6.24 Block diagram LB3104, FB3204

2-wire transmitter

Supply circuit: channel I 1+, 2-, channel II 5+, 6-, channel III 9+, 10-, channel IV 13+, 14-

3-wire transmitter

Supply circuit: channel I 1+, 4-, channel II 5+, 8-, channel III 9+, 12-, channel IV 13+, 16-
Measuring circuit: channel I 3+, 4-, channel II 7+, 8-, channel III 11+, 12-, channel IV 15+, 16-

4-wire transmitter (powered externally)

Measuring circuit: channel I 3+, 4-, channel II 7+, 8-, channel III 11+, 12-, channel IV 15+, 16-

Input resistance: 15 Ω (channel I: 3, 4; channel II: 7, 8; channel III: 11, 12; channel IV: 15, 16)

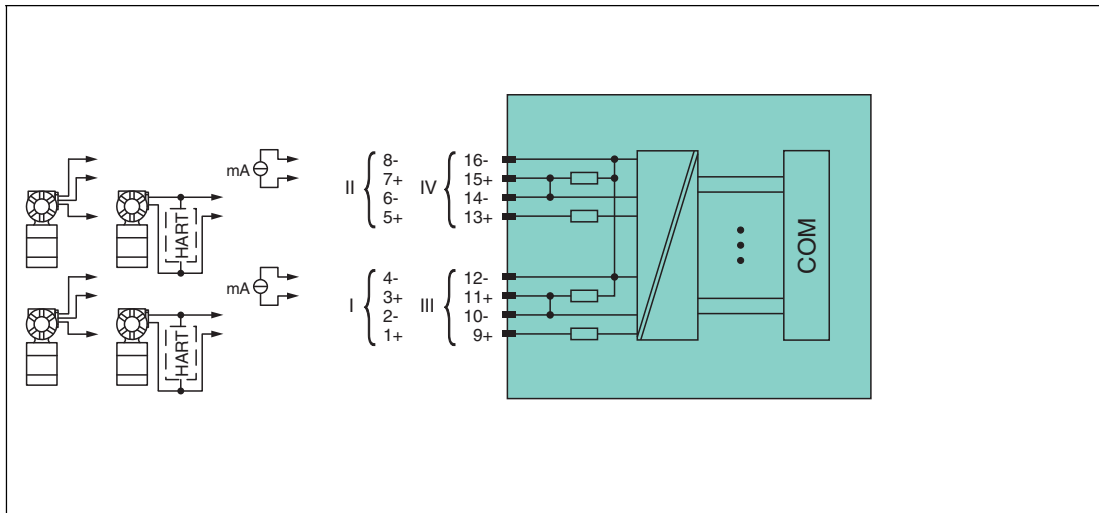

Figure 6.25 Block diagram LB3*05, FB3*05

2-wire transmitter (HART)

Supply circuit: channel I 1+, 2-, channel II 5+, 6-, channel III 9+, 10-, channel IV 13+, 14-

3-wire transmitter

Supply circuit: channel I 1+, 4-, channel II 5+, 8-, channel III 9+, 12-, channel IV 13+, 16-

Measuring circuit: channel I 3+, 4-, channel II 7+, 8-, channel III 11+, 12-, channel IV 15+, 16-

4-wire transmitter (powered externally)

Measuring circuit: channel I 3+, 4-, channel II 7+, 8-, channel III 11+, 12-, channel IV 15+, 16-

Input resistance: 15 Ω (channel I: 3, 4; channel II: 7, 8; channel III: 11, 12; channel IV: 15, 16)

Refer to the corresponding data sheet and operating instructions for further information.

6.14.2 Resolution

Input signals within a range of 0 mA ... 25 mA are detected with a resolution of 12 bits. The actual measuring range is calculated based on this resolution.

For the range between 4 mA ... 20 mA (corresponds to 0 % ... 100 %), a resolution of 2500 measurement points is obtained, which corresponds to 0.04 %. Underranges and overranges are taken into consideration.

6.14.3 Measuring Time and Cycle Time

The conversion time for all 4 channels together is approx. 80 ms. The accuracy of the measured value depends on the cycle time of the data traffic on the bus. The signals are transmitted to the com unit every 6.5 ms irrespective of the measuring time.

During HART communication, new values are only transmitted to the com unit every third internal data cycle. 50 ms is required for this. In the worst case scenario, the total time is therefore 130 ms.

6.14.4 Data Transfer

Data is transferred as specified in the PROFIBUS specification.

Successful PROFIBUS communication requires that the configuration, in particular the DP configuration string, in the master and the remote I/O station are identical. The configuration parameters are stored in the GSD/GSE file.

If the GSD/GSE file can be incorporated into the master, the DP configuration code for the relevant I/O module is copied automatically. If the GSD/GSE file cannot be incorporated, the configuration parameters must be entered in accordance with the table in this chapter. In addition to the GSD/GSE file, there are drivers available for further integration into various masters. The drivers provide the signals for the remote I/O station in processed format, meaning a manual integration of the I/O data in the data structures of the master is unnecessary.

The process data for each channel is transferred in unsigned integers within a range from 0 ... 65,535.

A data word (=16 bit) is available for each channel for the data transfer. The least significant 4 bits are of little importance for the accuracy of the measured value and are therefore used for transferring status information.



Note!

Dual-Width I/O Module

Dual-width I/O modules occupy two slots. Therefore, always configure an empty slot after this I/O module unless it is the last I/O module in a Remote I/O station. See chapter 6.1

Bit Structure Within the Data Telegram

DP configuration code 53		
Byte	Bit	Description
Input byte 1 (low byte)	0	Live zero if current 3.6 mA (*)
	1	Line fault detection channel 1 (0 = OK, 1 = error)
	2 ... 3	Empty
	4 ... 7	Measured value channel 1 (12 bit)
Input byte 2 (high byte)	0 ... 7	
Input bytes 3 ... 8		Same structure as input bytes 1 and 2 for channel 1
Output bytes		Without output bytes
(*) The live zero monitoring transmits an error bit (= 1) if the current falls below the minimum of 3.6 mA.		

6.14.5 Line Fault Detection

The line fault detection can detect a lead breakage or short circuit and can be switched off on a channel-by-channel basis.

You can preset the switching points at which a lead breakage or a short circuit is signaled, e.g., line breakage < 1 mA and short circuit > 21 mA.

The current circuit has Live Zero monitoring. If the current falls below the minimum of 3.6 mA, an error bit is set (= 1).

6.14.6 Editing Device Data

All I/O module parameters that can be configured via the PROFIBUS class 1 master are listed below. See chapter 4

If the PROFIBUS class 1 master is not yet ready for operation, e.g., during partial commissioning, the remote I/O station can be configured with the help of the DTM and an external FDT framework application such as PACTware™. See chapter 5

If you are operating a master that has drivers or libraries, you do not need to worry about the octet strings. You only need to enter the relevant parameters.

All parameters are valid for each channel.

LB3104, FB3204

DP configuration string: 0x53
parameter string **3x04**: 0x34, data_1, ... , data_4

Data_1 ... data_4 (channel 1 ... channel 4)

Bit	Parameters	Selection
0	Line fault detection	0 = off 1 = on
1	Operating mode	0 = 4 ... 20 mA (live zero) 1 = 0 ... 20 mA (dead zero)
2 ... 3	Analog filter	0 = off 1 = 100 %/s 2 = 10 %/s 3 = 1 %/s
4 ... 7	–	–

LB3*05, FB3*05

DP configuration string: 0x53
parameter string **3x05**: 0x35, data_1, ... , data_4

Data_1 ... data_4 (channel 1 ... channel 4)

Bit	Parameters	Selection
0	Line fault detection	0 = off 1 = on
1	Operating mode	0 = 4 ... 20 mA (live zero) 1 = 0 ... 20 mA (dead zero)
2 ... 3	Analog filter	0 = off 1 = 100 %/s 2 = 10 %/s 3 = 1 %/s
4 ... 5	–	–
6 ... 7	Substitute value	0 = current value 1 = -2.5 % 2 = 106.25 % 3 = last valid value

Line fault detection

Activate line fault detection to monitor the connection at the field end. In the event of a fault (e.g., lead breakage or short circuit), corresponding diagnostics are transmitted.

Operating mode

The **Operating mode** parameter defines the operating range of the I/O module with 0 ... 20 mA (Dead Zero) or 4 ... 20 mA (Live Zero).

Analog filter

The analog filter for damping the signal can be activated if the input signals fluctuate. The value defines the rate of change of the input value in % per second. On the slowest setting of 1 %/s, it takes 90 seconds for a 90 % modification of the input signal to pass through the filter completely. The measurement range is used as the reference value (characteristic: ramp, linear).

Substitute value

The I/O module may issue substitute values in the event of an error. See chapter 6.2

Preferred Parameter Values

Parameters	Values
Line fault detection	Off
Operating mode	4 mA ... 20 mA
Analog filter	Off
Substitute value	Current value

6.15 LB3*06 HART transmitter power supply

6.15.1 Description

Versions

- LB3006, HART transmitter power supply, not intrinsically safe
- LB3106, HART transmitter power supply, intrinsically safe

Features

- Occupies 1 slot on the backplane
- Number of channels: 4
- Suitable field devices: pressure, differential pressure, filling level, flow rate, and temperature converters, etc.

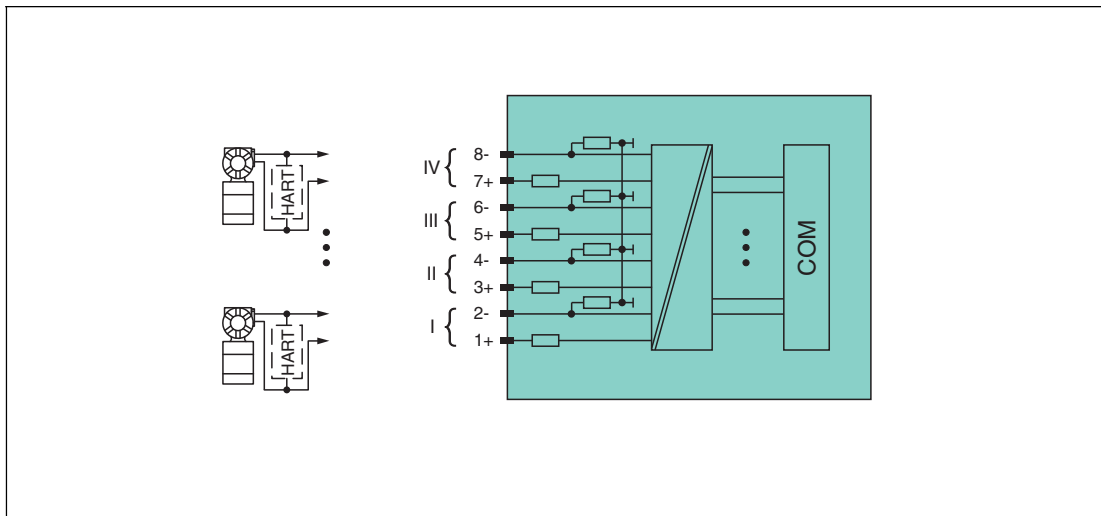

Figure 6.26 Block diagram LB3*06

The connection layout and other technical data can be found on the relevant data sheet.

6.15.2 Measuring Time and Cycle Time

The conversion time for all 4 channels together is approx. 80 ms. The accuracy of the measured value depends on the cycle time of the data traffic on the bus. The signals are transmitted to the com unit every 6.5 ms irrespective of the measuring time.

During HART communication, new values are only transmitted to the com unit every third internal data cycle. 50 ms is required for this. In the worst case scenario, the total time is therefore 130 ms.

6.15.3 Data Transfer

Data is transferred as specified in the PROFIBUS specification.

Successful PROFIBUS communication requires that the configuration, in particular the DP configuration string, in the master and the remote I/O station are identical. The configuration parameters are stored in the GSD/GSE file.

If the GSD/GSE file can be incorporated into the master, the DP configuration code for the relevant I/O module is copied automatically. If the GSD/GSE file cannot be incorporated, the configuration parameters must be entered in accordance with the table in this chapter. In addition to the GSD/GSE file, there are drivers available for further integration into various masters. The drivers provide the signals for the remote I/O station in processed format, meaning a manual integration of the I/O data in the data structures of the master is unnecessary.

The process data for each channel is transferred in unsigned integers within a range from 0 ... 65,535.

A data word (=16 bit) is available for each channel for the data transfer. The least significant 4 bits are of little importance for the accuracy of the measured value and are therefore used for transferring status information.

Bit Structure within the Data Telegram

DP configuration code 53		
Octet	Bit	Meaning
Input octet 1 (low octet)	0	Live zero if current \leq 3.6 mA (*)
	1	Line fault detection channel 1 (0 = OK, 1 = error)
	2 ... 3	Empty
	4 ... 7	Measured value channel 1 (12 bit)
Input octet 2 (high octet)	0 ... 7	
Input octets 3 ... 8		Same structure as input octets 1 and 2 for channel 1
Output octets		Without output octets
(*) The live zero monitoring transmits one error bit (= 1) if the current falls below the minimum of 3.6 mA.		

6.15.4 Line Fault Detection

The line fault detection can detect a lead breakage or short circuit and can be switched off on a channel-by-channel basis.

You can preset the switching points at which a lead breakage or a short circuit is signaled, e.g., line breakage < 1 mA and short circuit > 21 mA.

The current circuit has Live Zero monitoring. If the current falls below the minimum of 3.6 mA, an error bit is set (= 1).

6.15.5 Editing Device Data

All I/O module parameters that can be configured via the PROFIBUS class 1 master are listed below. See chapter 4

If the PROFIBUS class 1 master is not yet ready for operation, e.g., during partial commissioning, the remote I/O station can be configured with the help of the DTM and an external FDT framework application such as PACTware™. See chapter 5

If you are operating a master that has drivers or libraries, you do not need to worry about the octet strings. You only need to enter the relevant parameters.

All parameters are valid for each channel.

DP configuration string: 0x53
parameter string **3x06**: 0x36, data_1, ..., data_4

Data_1 ... Data_4 (Channel 1 ... Channel 4)

Bit	Parameter	Selection
0	Line fault detection	0 = off 1 = on
1	Operating mode	0 = 4 ... 20 mA (live zero) 1 = 0 ... 20 mA (dead zero)
2 ... 3	Analog filter	0 = off 1 = 100 %/s 2 = 10 %/s 3 = 1 %/s
4 ... 5	–	–
6 ... 7	Substitute value	0 = current value 1 = -2.5 % 2 = 106.25 % 3 = last valid value

Line fault detection

Activate line fault detection to monitor the connection at the field end. In the event of a fault (e.g., lead breakage or short circuit), corresponding diagnostics are transmitted.

Operating mode

The **Operating mode** parameter defines the operating range of the I/O module with 0 ... 20 mA (Dead Zero) or 4 ... 20 mA (Live Zero).

Analog filter

The analog filter for damping the signal can be activated if the input signals fluctuate. The value defines the rate of change of the input value in % per second. On the slowest setting of 1 %/s, it takes 90 seconds for a 90 % modification of the input signal to pass through the filter completely. The measurement range is used as the reference value (characteristic: ramp, linear).

Substitute value

The I/O module may issue substitute values in the event of an error. See chapter 6.2

Preferred Parameter Values

Parameter	Values
Line fault detection	Off
Operating mode	4 mA ... 20 mA
Analog filter	Off
Substitute value	Current value

6.16 LB4101, FB4*01 Current Output
LB4*02, FB4*02 HART Current Output

6.16.1 Description

Versions

- LB4101, current output, intrinsically safe
- FB4201, current output, intrinsically safe
- LB4002, HART current output, not intrinsically safe
- FB4302, HART current output, increased safety terminals
Versions with bus-independent shutdown input are available
- LB4102, HART current output, intrinsically safe
Versions with bus-independent shutdown input are available
- FB4202, HART current output, intrinsically safe
Versions with bus-independent shutdown input are available.

Features

- Occupies 1 slot on the backplane
- Number of channels: 1
- Suitable field devices: proportional valves, I/P converters, local indicators

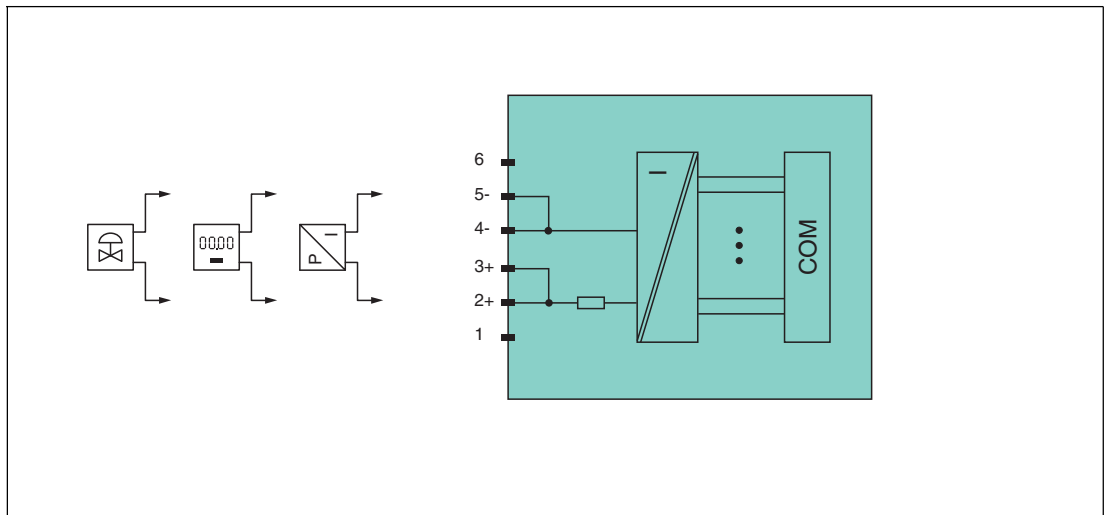

Figure 6.27 Block diagram LB4101, FB4*01

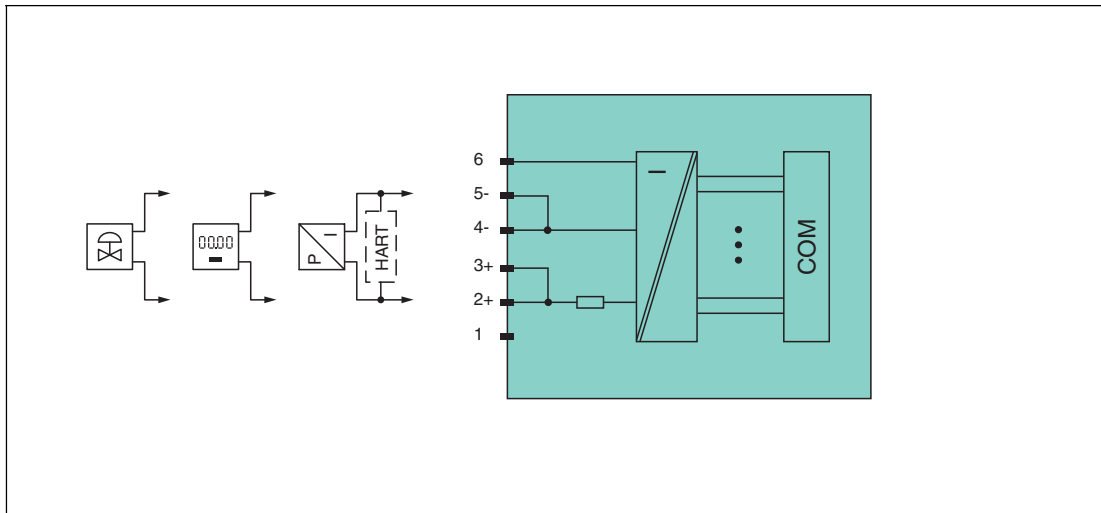

Figure 6.28 Block diagram LB4*02, FB4*02 without shutdown input

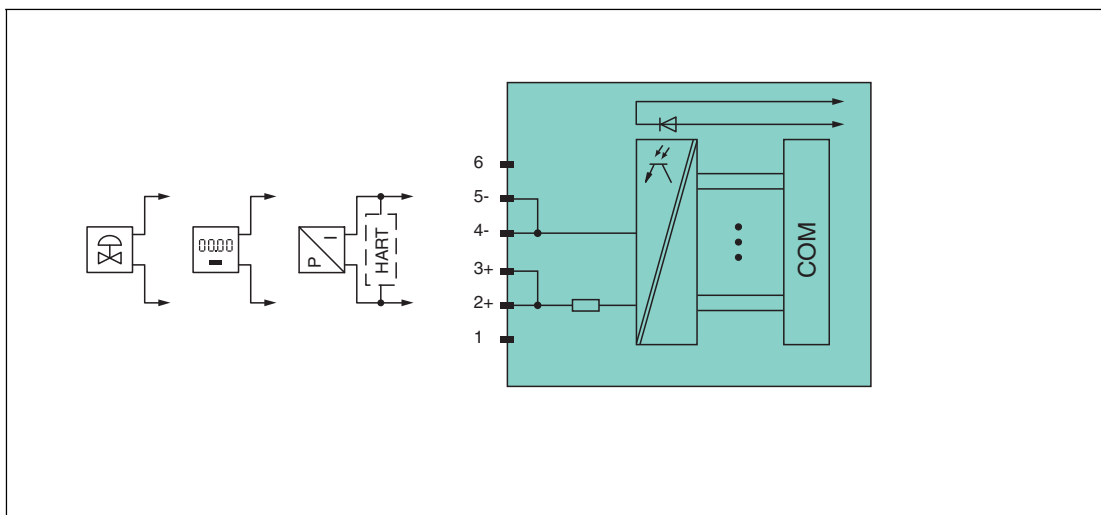

Figure 6.29 Block diagram LB4*02, FB4*02 with shutdown input

Refer to the corresponding data sheet and operating instructions for further information.

6.16.2 Resolution

Output signals within a range of 0 mA ... 25 mA are generated with a resolution of 12 bits. The actual measuring range is calculated based on this resolution. For the range between 4 mA ... 20 mA (corresponds to 0 % ... 100 %), a resolution of 2500 measurement points is obtained, which corresponds to 0.04 %.

6.16.3 Measuring Time and Cycle Time

The conversion time is approx. 50 ms. The accuracy of the measured value depends on the cycle time of the data traffic on the bus. The signals are transmitted to the com unit every 6.5 ms irrespective of the measuring time.

6.16.4 Data Transfer

Data is transferred as specified in the PROFIBUS specification.

Successful PROFIBUS communication requires that the configuration, in particular the DP configuration string, in the master and the remote I/O station are identical. The configuration parameters are stored in the GSD/GSE file.

If the GSD/GSE file can be incorporated into the master, the DP configuration code for the relevant I/O module is copied automatically. If the GSD/GSE file cannot be incorporated, the configuration parameters must be entered in accordance with the table in this chapter. In addition to the GSD/GSE file, there are drivers available for further integration into various masters. The drivers provide the signals for the remote I/O station in processed format, meaning a manual integration of the I/O data in the data structures of the master is unnecessary.

The process data for each channel is transferred in unsigned integers within a range from 0 ... 65535.

One data word (16 bit) word per channel is available for data transfer. The most significant 12 bits are used.

Bit Structure within the Data Telegram

DP configuration code 60		
Byte	Bit	Description
Input bytes		Without input bytes
Output byte 1 (low byte)	0 ... 3	Empty
	4 ... 7	Process value (12 bit)
Output byte 2 (high byte)	0 ... 7	

6.16.5 Line Fault Detection

The line fault detection can detect a line breakage and can be switched off on a channel-by-channel basis.

Line fault detection works on the basis of measuring a minimum current of 1 mA. The current still flows even when the control system specifies 0 mA. The line fault detection function is therefore unsuitable for 0 mA ... 20 mA outputs. When currents < 0.1 mA are detected, a lead breakage is signaled.

6.16.6 Watchdog

The I/O module has a watchdog function. If the communication between the I/O module and com unit stops, the I/O module enters the safe state after 0.5 s.

6.16.7 Editing Device Data

All I/O module parameters that can be configured via the PROFIBUS class 1 master are listed below. See chapter 4

If the PROFIBUS class 1 master is not yet ready for operation, e.g., during partial commissioning, the remote I/O station can be configured with the help of the DTM and an external FDT framework application such as PACTware™. See chapter 5

If you are operating a master that has drivers or libraries, you do not need to worry about the octet strings. You only need to enter the relevant parameters.

All parameters are valid for each channel.

DP configuration string: 0x60
parameter string 4x01: 0x41, data_1
parameter string 4x02: 0x42, data_1

Data_1

Bit	Parameters	Selection
0	Line fault detection	0 = off 1 = on
1	Operating mode	0 = 4 ... 20 mA (live zero) 1 = 0 ... 20 mA (dead zero)
2 ... 3	Analog filter	0 = off 1 = 100 %/s 2 = 10 %/s 3 = 1 %/s
4 ... 6	Substitute value	0 = 0 mA 1 = 4 mA 2 = 20 mA 3 = 25 mA 4 = last valid value 5 = current value
7	Minimum output value	0 = 0 mA 1 = 4 mA

Line fault detection

Activate line fault detection to monitor the connection at the field end. In the event of a fault (e.g., lead breakage or short circuit), corresponding diagnostics are transmitted.

Operating mode

The **Operating mode** parameter defines the operating range of the I/O module with 0 ... 20 mA (Dead Zero) or 4 ... 20 mA (Live Zero).

Analog filter

The analog filter for damping the signal can be activated if the output signals fluctuate. Enter a value in % for defining the rate of change of the output value for each second. The measurement range is used as the reference value (characteristic: ramp, linear).

Substitute value

The I/O module may issue substitute values in the event of an error. See chapter 6.2

Minimum output value

Use this parameter for field devices that require a minimum current to operate correctly. Note that HART communication also requires a minimum current. If the function is activated, the I/O module ignores all values transferred by the process control system that are below the minimum current value and transmits the minimum output value instead. To disable the feature, use the setting 0 = 0 mA.

Preferred Parameter Values

Parameters	Values
Line fault detection	Off
Analog filter	Off
Operating mode	4 mA ... 20 mA
Substitute value	Current value
Minimum output value	4 mA

6.16.8 Configuring Strain Gauge Measurement

I/O modules LB4101 and LB5*02 or FB4*01 and FB5202 can be interconnected for strain gauge measurements. Use analog output LB4101 or FB4*01 to create a constant current, and the measuring input for the temperature input LB5*02 or FB5202 to process the millivolt signal for the resulting bridge voltage.

A constant current of 20 mA is sufficient for the bridge voltage for a 350 Ω bridge. A bridge voltage of 7 V is produced. With a bridge sensitivity of 2 mV/V, a voltage of 14 mV results at full load.



Configuring I/O Modules for Strain Gauge Measurement

1. Set a fixed value of 20 mA via the fieldbus for the analog output LB4101 or FB4*01.
2. Set the LB5*02 and FB5202 temperature input to a millivolt measurement.
3. Select an external cold junction for the temperature input LB5*02 or FB5202.
4. Deactivate cold junction compensation for LB5*02 and FB5202 temperature input by setting the thermostat temperature for the external cold junction to 0 °C.



Note!

Accuracy

The combination of the two I/O modules produces an overall accuracy of approx. 0.2 %. The accuracy is comprised as follows.

Current source LB4101 or FB4*01 equates to 0.1 %

millivolt amplifier LB5*02 or FB5202 PC equates to 0.1 %

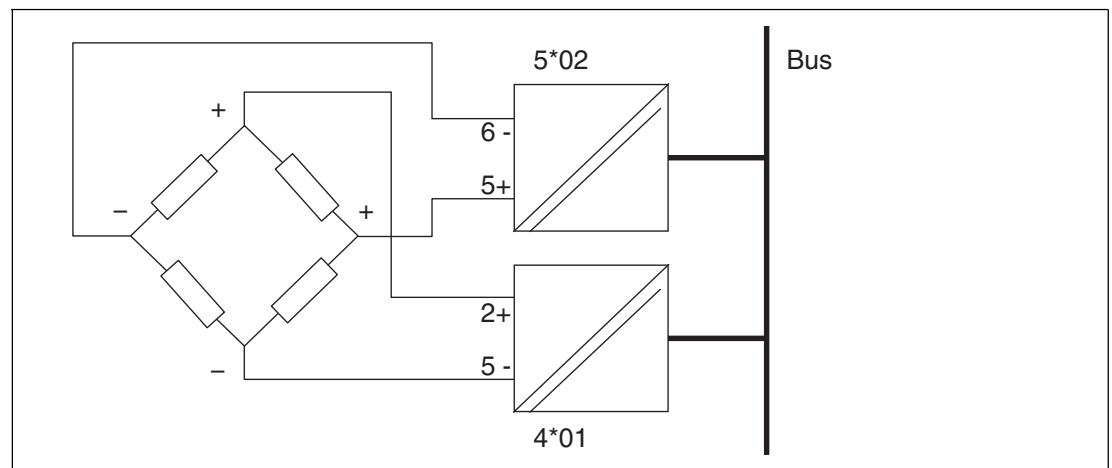

Figure 6.30 Example of a strain gauge bridge

6.17 LB4104, FB4204 Current Output
LB4*05, FB4*05 HART Current Output

6.17.1 Description

Versions

- LB4104, current output, intrinsically safe
- FB4204, current output, intrinsically safe
- LB4005, HART current output, not intrinsically safe
Versions available with bus-independent shutdown input
- FB4305, HART current output, increased safety terminals
Versions available with bus-independent shutdown input
- LB4105, HART current output, intrinsically safe
Versions available with bus-independent shutdown input
- FB4205, HART current output, intrinsically safe
Versions available with bus-independent shutdown input

Features

- Occupies 2 slots on the backplane
- Number of channels: 4
- Suitable field devices: proportional valves, I/P converters, local indicators

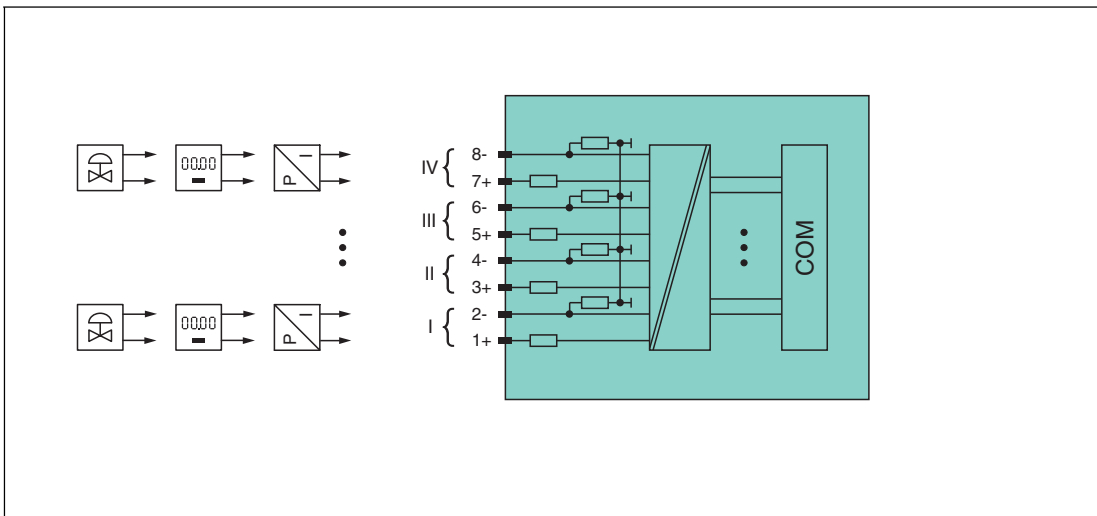

Figure 6.31 Block diagram LB4104, FB4204

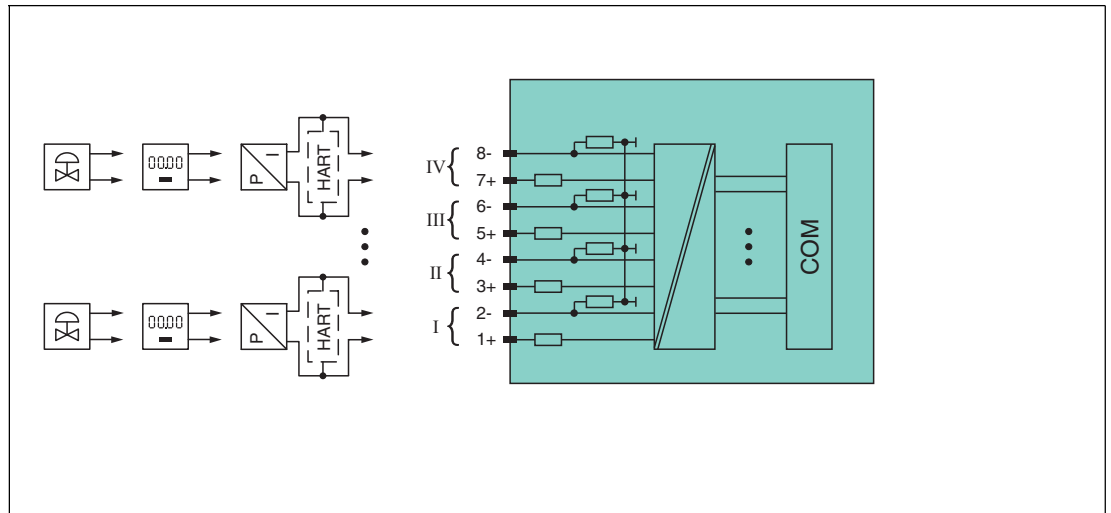

Figure 6.32 Block diagram LB4*05, FB4*05 without shutdown input

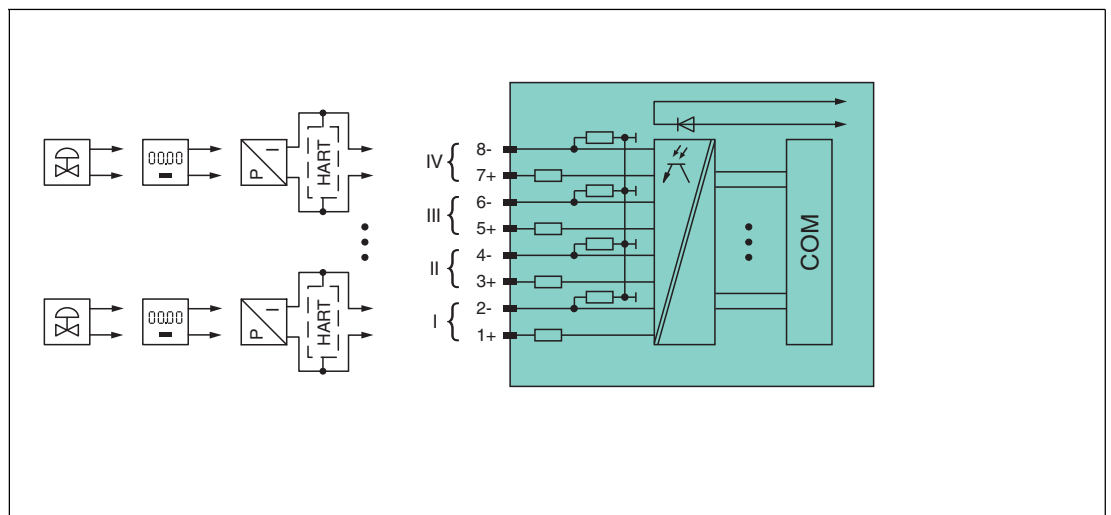

Figure 6.33 Block diagram LB4*05, FB4*05 with shutdown input

Refer to the corresponding data sheet and operating instructions for further information.

6.17.2 Resolution

Output signals within a range of 0 mA ... 25 mA are generated with a resolution of 12 bits. The actual measuring range is calculated based on this resolution. For the range between 4 mA ... 20 mA (corresponds to 0 % ... 100 %), a resolution of 2500 measurement points is obtained, which corresponds to 0.04 %.

6.17.3 Measuring Time and Cycle Time

The conversion time for all 4 channels together is approx. 60 ms. During HART communication, this time increases to 110 ms. However, the accuracy of the measured value depends on the cycle time of the data traffic on the bus. The signals are transmitted to the com unit every 6.5 ms irrespective of the measuring time.

6.17.4 Data Transfer

Data is transferred as specified in the PROFIBUS specification.

Successful PROFIBUS communication requires that the configuration, in particular the DP configuration string, in the master and the remote I/O station are identical. The configuration parameters are stored in the GSD/GSE file.

If the GSD/GSE file can be incorporated into the master, the DP configuration code for the relevant I/O module is copied automatically. If the GSD/GSE file cannot be incorporated, the configuration parameters must be entered in accordance with the table in this chapter. In addition to the GSD/GSE file, there are drivers available for further integration into various masters. The drivers provide the signals for the remote I/O station in processed format, meaning a manual integration of the I/O data in the data structures of the master is unnecessary.

The process data for each channel is transferred in unsigned integers within a range from 0 ... 65535.

One data word (16 bit) word per channel is available for data transfer. The most significant 12 bits are used.



Note!

Dual-Width I/O Module

Dual-width I/O modules occupy two slots. Therefore, always configure an empty slot after this I/O module unless it is the last I/O module in a Remote I/O station. See chapter 6.1

The line fault detection is available for the analog output LB4*05 or FB4*05 in version 1.09 or higher of the GSD/GSE file only.

Bit Structure within the Data Telegram

DP configuration code C0 43 40		
Byte	Bit	Description
Input byte 1 (low byte)	0	Empty
	1	Line fault detection channel 1 (0 = OK, 1 = error)
	2 ... 4	Empty
	5	Line fault detection channel 2 (0 = OK, 1 = error)
	6 ... 7	Empty
Input byte 2 (high byte)	0	Empty
	1	Line fault detection channel 3 (0 = OK, 1 = error)
	2 ... 4	Empty
	5	Line fault detection channel 4 (0 = OK, 1 = error)
	6 ... 7	Empty
Output byte 1 (low byte)	0	Empty
	1	Invalid channel 1
	2 ... 3	Empty
	4 ... 7	Process value channel 1 (12 bit)
Output byte 2 (high byte)	0 ... 7	
Output bytes 3 ... 8		Same structure as output bytes 1 and 2 for channel 1

6.17.5 Line Fault Detection



Note!

The LB4*05, FB4*05 I/O module is available with and without line fault detection. The com unit and the operator interface are the same across the various versions, however. Note, therefore, that the line fault detection settings relate to I/O modules with line fault detection only.

The line fault detection can detect a line breakage and can be switched off on a channel-by-channel basis.

Line fault detection works on the basis of measuring a minimum current of 1 mA. The current still flows even when the control system specifies 0 mA. The line fault detection function is therefore unsuitable for 0 mA ... 20 mA outputs. When currents < 0.1 mA are detected, a lead breakage is signaled.

6.17.6 Watchdog

The I/O module has a watchdog function. If the communication between the I/O module and com unit stops, the I/O module enters the safe state after 0.5 s.

6.17.7 Editing Device Data

All I/O module parameters that can be configured via the PROFIBUS class 1 master are listed below. See chapter 4

If the PROFIBUS class 1 master is not yet ready for operation, e.g., during partial commissioning, the remote I/O station can be configured with the help of the DTM and an external FDT framework application such as PACTware™. See chapter 5

If you are operating a master that has drivers or libraries, you do not need to worry about the octet strings. You only need to enter the relevant parameters.

All parameters are valid for each channel.

DP configuration string: 0xC0, 0x43, 0x40
parameter string **4x04**: 0x44, data_1, ..., data_4
parameter string **4x05**: 0x45, data_1, ..., data_4

Data_1 ... data_4 (channel 1 ... channel 4)

Bit	Parameters	Selection
0	Line fault detection (only for LB4*05 or FB4*05 in version 1.09 or higher of the GSD/GSE file)	0 = off 1 = on
1	Operating mode	0 = 4 ... 20 mA (live zero) 1 = 0 ... 20 mA (dead zero)
2 ... 3	Analog filter	0 = off 1 = 100 %/s 2 = 10 %/s 3 = 1 %/s
4 ... 6	Substitute value	0 = 0 mA 1 = 4 mA 2 = 20 mA 3 = 25 mA 4 = last valid value 5 = current value
7	Minimum output value	0 = 0 mA 1 = 4 mA

Operating mode

The **Operating mode** parameter defines the operating range of the I/O module with 0 ... 20 mA (Dead Zero) or 4 ... 20 mA (Live Zero).

Analog filter

The analog filter for damping the signal can be activated if the output signals fluctuate. Enter a value in % for defining the rate of change of the output value for each second. The measurement range is used as the reference value (characteristic: ramp, linear).

Substitute value

The I/O module may issue substitute values in the event of an error. See chapter 6.2

Minimum output value

Use this parameter for field devices that require a minimum current to operate correctly. Note that HART communication also requires a minimum current. If the function is activated, the I/O module ignores all values transferred by the process control system that are below the minimum current value and transmits the minimum output value instead. To disable the feature, use the setting 0 = 0 mA.

Preferred Parameter Values

Parameters	Values
Line fault detection	Off
Analog filter	Off
Operating mode	4 mA ... 20 mA
Substitute value	Current value
Minimum output value	4 mA

6.18 LB4106 HART Current Output

6.18.1 Description

Versions

LB4106, HART current output, intrinsically safe
Versions with bus-independent shutdown input are available.

Features

- Occupies 1 slot on the backplane
- Number of channels: 4
- Suitable field devices: proportional valves, I/P converters, local indicators

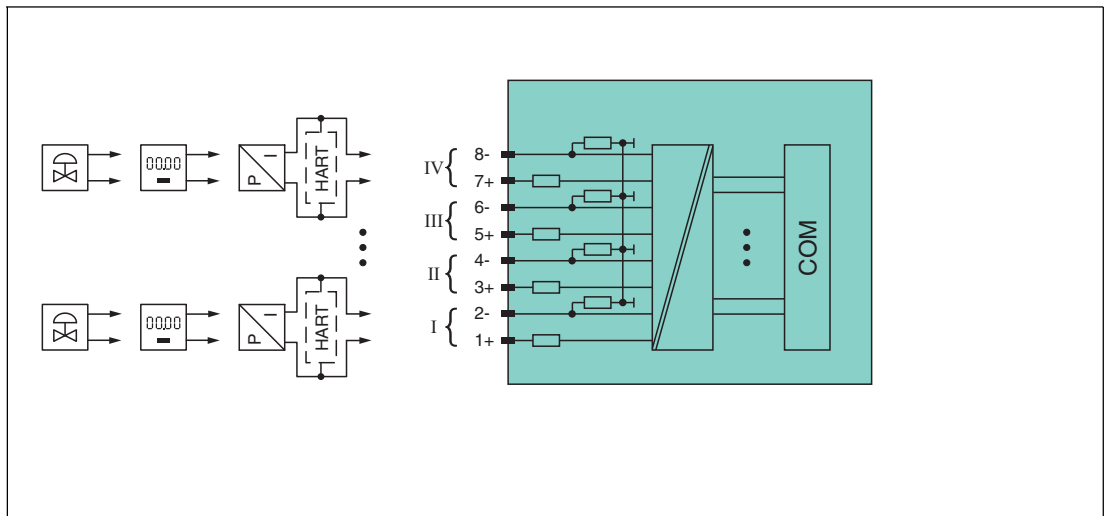

Figure 6.34 Block diagram LB4106 without shutdown input

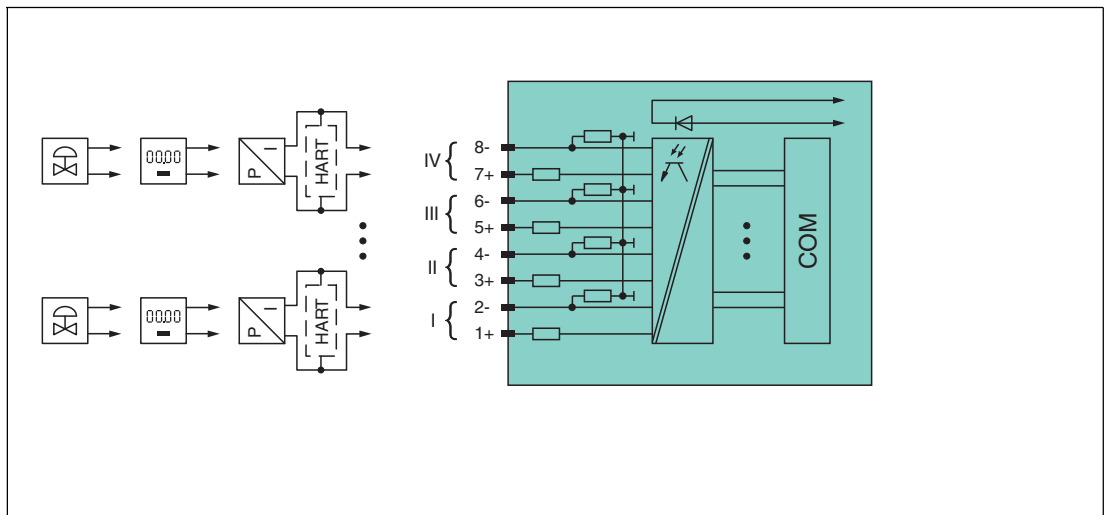

Figure 6.35 Block diagram LB4106 with shutdown input

The connection layout and other technical data can be found on the relevant data sheet.

6.18.2 Resolution

Output signals within a range of 0 mA ... 25 mA are generated with a resolution of 12 bits. The actual measuring range is calculated based on this resolution. For the range between 4 mA ... 20 mA (corresponds to 0 % ... 100 %), a resolution of 2500 measurement points is obtained, which corresponds to 0.04 %.

6.18.3 Measuring Time and Cycle Time

The conversion time for all 4 channels together is approx. 60 ms. During HART communication, this time increases to 110 ms. However, the accuracy of the measured value depends on the cycle time of the data traffic on the bus. The signals are transmitted to the com unit every 6.5 ms irrespective of the measuring time.

6.18.4 Data Transfer

Data is transferred as specified in the PROFIBUS specification.

Successful PROFIBUS communication requires that the configuration, in particular the DP configuration string, in the master and the remote I/O station are identical. The configuration parameters are stored in the GSD/GSE file.

If the GSD/GSE file can be incorporated into the master, the DP configuration code for the relevant I/O module is copied automatically. If the GSD/GSE file cannot be incorporated, the configuration parameters must be entered in accordance with the table in this chapter. In addition to the GSD/GSE file, there are drivers available for further integration into various masters. The drivers provide the signals for the remote I/O station in processed format, meaning a manual integration of the I/O data in the data structures of the master is unnecessary.

The process data for each channel is transferred in unsigned integers within a range from 0 ... 65535.

One data word (16 bit) word per channel is available for data transfer. The most significant 12 bits are used.

Bit Structure within the Data Telegram

DP configuration code C0 43 40		
Byte	Bit	Description
Input byte 1 (low byte)	0	Empty
	1	Line fault detection channel 1 (0 = OK, 1 = error)
	2 ... 4	Empty
	5	Line fault detection channel 2 (0 = OK, 1 = error)
	6 ... 7	Empty
Input byte 2 (high byte)	0	Empty
	1	Line fault detection channel 3 (0 = OK, 1 = error)
	2 ... 4	Empty
	5	Line fault detection channel 4 (0 = OK, 1 = error)
	6 ... 7	Empty
Output byte 1 (low byte)	0	Empty
	1	Invalid channel 1
	2 ... 3	Empty
	4 ... 7	Process value channel 1 (12 bit)
Output byte 2 (high byte)	0 ... 7	
Output bytes 3 ... 8		Same structure as output bytes 1 and 2 for channel 1

200337 2016-03

6.18.5 Line Fault Detection

The line fault detection can detect a line breakage and can be switched off on a channel-by-channel basis.

Line fault detection works on the basis of measuring a minimum current of 1 mA. The current still flows even when the control system specifies 0 mA. The line fault detection function is therefore unsuitable for 0 mA ... 20 mA outputs. When currents < 0.1 mA are detected, a lead breakage is signaled.

6.18.6 Watchdog

The I/O module has a watchdog function. If the communication between the I/O module and com unit stops, the I/O module enters the safe state after 0.5 s.

6.18.7 Editing Device Data

All I/O module parameters that can be configured via the PROFIBUS class 1 master are listed below. See chapter 4

If the PROFIBUS class 1 master is not yet ready for operation, e.g., during partial commissioning, the remote I/O station can be configured with the help of the DTM and an external FDT framework application such as PACTware™. See chapter 5

If you are operating a master that has drivers or libraries, you do not need to worry about the octet strings. You only need to enter the relevant parameters.

All parameters are valid for each channel.

DP configuration string: 0xC0, 0x43, 0x40
parameter string **4x06**: 0x46, data_1, ..., data_4

Data_1 ... data_4 (channel 1 ... channel 4)

Bit	Parameters	Selection
0	Line fault detection	0 = off 1 = on
1	Operating mode	0 = 4 ... 20 mA (live zero) 1 = 0 ... 20 mA (dead zero)
2 ... 3	Analog filter	0 = off 1 = 100 %/s 2 = 10 %/s 3 = 1 %/s
4 ... 6	Substitute value	0 = 0 mA 1 = 4 mA 2 = 20 mA 3 = 25 mA 4 = last valid value 5 = current value
7	Minimum output value	0 = 0 mA 1 = 4 mA

Line fault detection

Activate line fault detection to monitor the connection at the field end. In the event of a fault (e.g., lead breakage or short circuit), corresponding diagnostics are transmitted.

Operating mode

The **Operating mode** parameter defines the operating range of the I/O module with 0 ... 20 mA (Dead Zero) or 4 ... 20 mA (Live Zero).

Analog filter

The analog filter for damping the signal can be activated if the output signals fluctuate. Enter a value in % for defining the rate of change of the output value for each second. The measurement range is used as the reference value (characteristic: ramp, linear).

Substitute value

The I/O module may issue substitute values in the event of an error. See chapter 6.2

Minimum output value

Use this parameter for field devices that require a minimum current to operate correctly. Note that HART communication also requires a minimum current. If the function is activated, the I/O module ignores all values transferred by the process control system that are below the minimum current value and transmits the minimum output value instead. To disable the feature, use the setting 0 = 0 mA.

Preferred Parameter Values

Parameters	Values
Line fault detection	Off
Analog filter	Off
Operating mode	4 mA ... 20 mA
Substitute value	Current value
Minimum output value	4 mA

6.19 LB5*01, FB5201 RTD Converter

6.19.1 Description

Versions

- LB5001, RTD converter, not intrinsically safe
- LB5101, RTD converter, intrinsically safe
- FB5201, RTD converter, intrinsically safe

Features

- Occupies 1 slot on the backplane
- Number of channels: 1
- Suitable sensors: 2-, 3- and 4-wire connection, resistance thermometer, slide-wire sensor up to 400 Ω

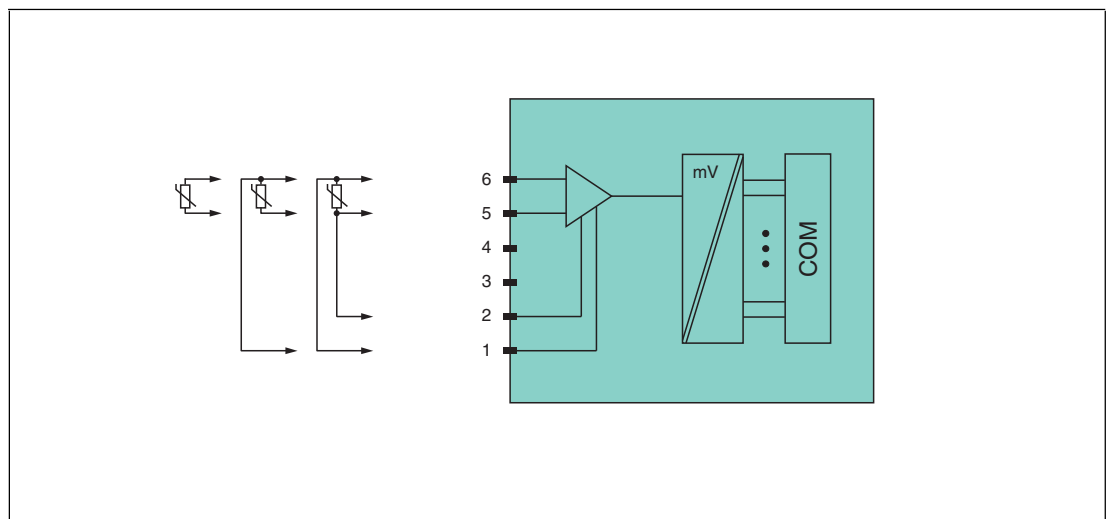

Figure 6.36 Block diagram LB5*01, FB5201

2-wire connection: 5, 6

3-wire connection: 1, 5, 6

4-wire connection: 1, 2, 5, 6

Refer to the corresponding data sheet and operating instructions for further information.

6.19.2 Resolution

Temperatures within a range of -200 °C ... 850 °C are detected with a resolution of 16 bits. The actual measuring range is calculated based on this resolution.

For the smallest span (0 % ... 100 %), a resolution of 2500 measurement points is obtained, which corresponds to 0.04 %.

6.19.3 Measuring Time and Cycle Time

The processing times depend on the preset measurement process.

- 20 ms without line fault detection
- 125 ms with line fault detection

The signals are transmitted to the com unit every 6.5 ms irrespective of the measuring time. A filter is available for smoothing the input signals.

6.19.4 Data Transfer

Data is transferred as specified in the PROFIBUS specification.

Successful PROFIBUS communication requires that the configuration, in particular the DP configuration string, in the master and the remote I/O station are identical. The configuration parameters are stored in the GSD/GSE file.

If the GSD/GSE file can be incorporated into the master, the DP configuration code for the relevant I/O module is copied automatically. If the GSD/GSE file cannot be incorporated, the configuration parameters must be entered in accordance with the table in this chapter. In addition to the GSD/GSE file, there are drivers available for further integration into various masters. The drivers provide the signals for the remote I/O station in processed format, meaning a manual integration of the I/O data in the data structures of the master is unnecessary.

The process data for each channel is transferred in unsigned integers within a range from 0 ... 65,535.

A data word (=16 bit) is available for each channel for the data transfer. The least significant 4 bits are of little importance for the accuracy of the measured value and are therefore used for transferring status information.

Bit Structure within the Data Telegram

DP configuration code 50		
Byte	Bit	Description
Input byte 1	0	Empty
	1	Line fault detection channel 1 (0 = OK, 1 = error)
	2 ... 3	Empty
	4 ... 7	Measured value (12 bit)
Input byte 2	0 ... 7	
Output bytes		Without output bytes

6.19.5 Line Fault Detection

The line fault detection can detect a lead breakage or short circuit and can be switched off on a channel-by-channel basis.

- Line breakage: Resistance > 1 kΩ with Pt100
- Short circuit: Resistance < 10 Ω with Pt100

The broken wire delay function waits until 10 faultless measuring cycles have been completed before enabling measured values to avoid constant toggling between OK/fault if there is a loose contact.

6.19.6 Editing Device Data

All I/O module parameters that can be configured via the PROFIBUS class 1 master are listed below. See chapter 4

If the PROFIBUS class 1 master is not yet ready for operation, e.g., during partial commissioning, the remote I/O station can be configured with the help of the DTM and an external FDT framework application such as PACTware™. See chapter 5

If you are operating a master that has drivers or libraries, you do not need to worry about the octet strings. You only need to enter the relevant parameters.

All parameters are valid for each channel.

DP configuration string: 0x50
parameter string: 0x51, data_1, data_2

Data_1

Bit	Parameters	Selection
0	Line fault detection	0 = off 1 = on
1 ... 2	Analog filter	0 = off 1 = 100 %/s 2 = 10 %/s 3 = 1 %/s
3 ... 4	Operating mode	0 = 4-wire 1 = 3-wire 2 = 2-wire (RI = 20 Ω)
5 ... 7	-	-

Data_2

Bit	Parameters	Selection
0 ... 4	Measurement range	Pt100 0 = -200 ... 850 °C 1 = -200 ... 300 °C 2 = 0 ... 500 °C 3 = 300 ... 850 °C 4 = 0 ... 100 °C 5 = 0 ... 200 °C 6 = 0 ... 300 °C 7 = -50 ... 50 °C Resistance 8 = 0 ... 400 Ω 9 = 0 ... 200 Ω 10 = 0 ... 100 Ω 11 = 0 ... 50 Ω
5 ... 7	-	-

Line fault detection

Activate line fault detection to monitor the connection at the field end. In the event of a fault (e.g., lead breakage or short circuit), corresponding diagnostics are transmitted.

Analog filter

The analog filter for damping the signal can be activated if the input signals fluctuate. The value defines the rate of change of the input value in % per second. On the slowest setting of 1 %/s, it takes 90 seconds for a 90 % modification of the input signal to pass through the filter completely. The measurement range is used as the reference value (characteristic: ramp, linear).

Operating mode

Specify how the sensor is connected (2, 3 or 4-wire configuration). With a 2-wire configuration, the resistance of the supply lines is preset permanently to RI = 20 Ω.

Measurement range

Select the correct measurement range in line with the connected sensor. The physical units differ depending on the sensor.



Preferred Parameter Values

Parameters	Values
Line fault detection	Off
Analog filter	Off
Operating mode	4-wire
Measurement range	Pt100: -200 °C ... 850 °C

6.20 LB5*02, FB5202 Thermocouple Converter

6.20.1 Description

Versions

- LB5002, thermocouple converter, not intrinsically safe
- LB5102, thermocouple converter, intrinsically safe
- FB5202, thermocouple converter, intrinsically safe

Features

- Occupies 1 slot on the backplane
- Number of channels: 1
- Suitable sensors: thermocouple types U, B, E, T, K, S, R, L, J, N, pallaplat and mV sensors

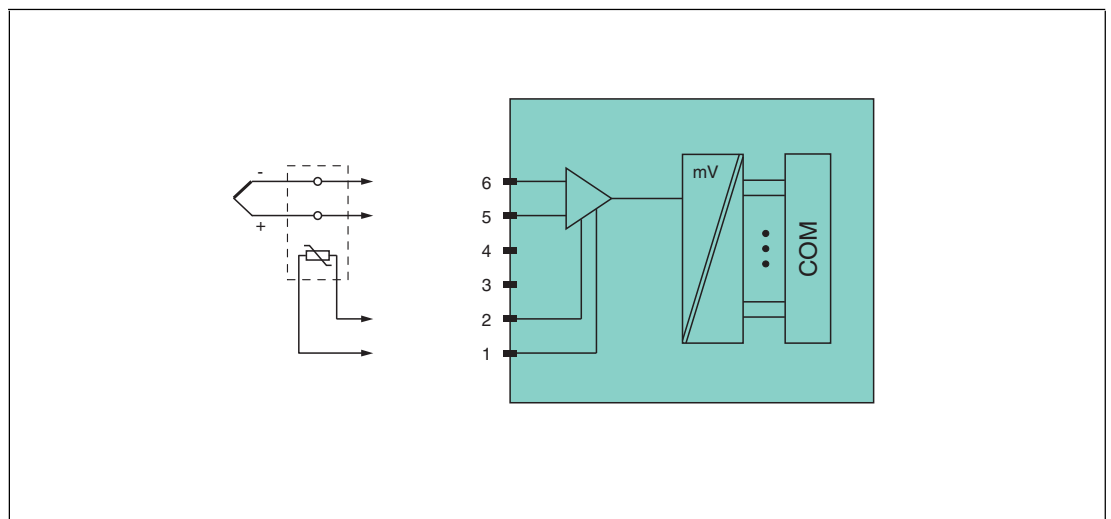

Figure 6.37 Block diagram LB5*02, FB5202

Cold junctions: 1, 2

Thermocouple: 5+, 6-

Refer to the corresponding data sheet and operating instructions for further information.

6.20.2 Resolution

Temperatures within a range of -200 °C ... 850 °C are detected with a resolution of 16 bits. The actual measuring range is calculated based on this resolution.

For the smallest span of 5 mV (0 % ... 100 %), a resolution of 2500 measurement points is obtained, which corresponds to 0.04 %.

All conventional thermocouple curves and pallaplat are linearized.

6.20.3 Measuring Time and Cycle Time

The processing times depend on the preset measurement process.

- **External reference junction (CJC)**
 - 20 ms without line fault detection
 - 80 ms with line fault detection
- **Internal reference junction (CJC)**
 - 120 ms without line fault detection
 - 240 ms with line fault detection

The signals are transmitted to the com unit every 6.5 ms irrespective of the measuring time. A filter is available for smoothing the input signals.

6.20.4 Data Transfer

Data is transferred as specified in the PROFIBUS specification.

Successful PROFIBUS communication requires that the configuration, in particular the DP configuration string, in the master and the remote I/O station are identical. The configuration parameters are stored in the GSD/GSE file.

If the GSD/GSE file can be incorporated into the master, the DP configuration code for the relevant I/O module is copied automatically. If the GSD/GSE file cannot be incorporated, the configuration parameters must be entered in accordance with the table in this chapter. In addition to the GSD/GSE file, there are drivers available for further integration into various masters. The drivers provide the signals for the remote I/O station in processed format, meaning a manual integration of the I/O data in the data structures of the master is unnecessary.

The process data for each channel is transferred in unsigned integers within a range from 0 ... 65,535.

A data word (=16 bit) is available for each channel for the data transfer. The least significant 4 bits are of little importance for the accuracy of the measured value and are therefore used for transferring status information.

Bit Structure within the Data Telegram

DP configuration code 50		
Byte	Bit	Description
Input byte 1	0	Empty
	1	Line fault detection channel 1 (0 = OK, 1 = error)
	2 ... 3	Empty
	4 ... 7	Measured value (12 bit)
Input byte 2	0 ... 7	
Output bytes		Without output bytes

6.20.5 Line fault detection

The line fault detection can detect a line breakage and can be disabled via software.

The broken wire delay function waits until 10 faultless cycles have been completed before enabling measured values to avoid constant toggling between OK/fault if there is a loose contact.

6.20.6 Editing Device Data

All I/O module parameters that can be configured via the PROFIBUS class 1 master are listed below. See chapter 4

If the PROFIBUS class 1 master is not yet ready for operation, e.g., during partial commissioning, the remote I/O station can be configured with the help of the DTM and an external FDT framework application such as PACTware™. See chapter 5

If you are operating a master that has drivers or libraries, you do not need to worry about the octet strings. You only need to enter the relevant parameters.

All parameters are valid for each channel.

DP configuration string: 0x50

parameter string: 0x52, data_1, data_2

Data_1

Bit	Parameters	Selection
0	Line fault detection	0 = off 1 = on
1 ... 2	Analog filter	0 = off 1 = 100 %/s 2 = 10 %/s 3 = 1 %/s
3	Cold junction	0 = internal 1 = external
4	Ext. cold junction temperature	0 = 0 °C 1 = 50 °C
5 ... 7	-	-

Data_2

Bit	Parameters	Selection
0 ... 5	Measurement range	mV 0 = -75 ... 75 mV 1 = 0 ... 75 mV 2 = 0 ... 50 mV 3 = 0 ... 25 mV Type U 4 = -200 ... 600 °C 5 = -200 ... 200 °C 6 = 0 ... 200 °C 7 = 200 ... 600 °C Type B 8 = 0 ... 1800 °C 9 = 0 ... 900 °C 10 = 450 ... 1350 °C 11 = 900 ... 1800 °C Type E 12 = -270 ... 1000 °C 13 = -270 ... 360 °C 14 = 50 ... 680 °C 15 = 360 ... 1000 °C Type T 16 = -270 ... 400 °C 17 = -270 ... 60 °C 18 = -100 ... 230 °C 19 = 60 ... 400 °C Type K 20 = -200 ... 1370 °C 21 = -200 ... 500 °C 22 = 150 ... 850 °C 23 = 500 ... 1370 °C Type S 24 = 0 ... 1760 °C 25 = 0 ... 900 °C 26 = 450 ... 1350 °C 27 = 900 ... 1760 °C Type R 28 = -50 ... 1750 °C 29 = -50 ... 900 °C 30 = 450 ... 1350 °C 31 = 900 ... 1750 °C Type L 32 = -200 ... 900 °C 33 = -200 ... 350 °C 34 = 75 ... 625 °C 35 = 350 ... 900 °C Type J 36 = -210 ... 1200 °C 37 = -200 ... 500 °C 38 = 150 ... 850 °C 39 = 500 ... 1200 °C Type N 40 = -200 ... 1350 °C 41 = -200 ... 600 °C 42 = 200 ... 1000 °C 43 = 500 ... 1350 °C Pallaplat 44 = -100 ... 1300 °C 45 = -100 ... 600 °C 46 = 250 ... 950 °C 47 = 600 ... 1300 °C
6 ... 7	-	-

200337 2016-03

Line fault detection

Activate line fault detection to monitor the connection at the field end. In the event of a fault (e.g., lead breakage or short circuit), corresponding diagnostics are transmitted.

Analog filter

The analog filter for damping the signal can be activated if the input signals fluctuate. The value defines the rate of change of the input value in % per second. On the slowest setting of 1 %/s, it takes 90 seconds for a 90 % modification of the input signal to pass through the filter completely. The measurement range is used as the reference value (characteristic: ramp, linear).

Cold junction

Select between an internal and external cold junction. If you have selected an external cold junction, specify the external cold junction temperature.

Ext. cold junction temperature

If you have selected an external cold junction, specify the temperature of the thermostat in use.

Measurement range

Select the correct measurement range in line with the connected sensor. The physical units differ depending on the sensor.

Preferred Parameter Values

Parameters	Values
Line fault detection	Off
Analog filter	Off
Cold junction	Internal
Ext. cold junction temperature	0 °C
Measurement range	Type U: -200 °C ... 600 °C

6.20.7 Configuring Strain Gauge Measurement

I/O modules LB4101 and LB5*02 or FB4*01 and FB5202 can be interconnected for strain gauge measurements. Use analog output LB4101 or FB4*01 to create a constant current, and the measuring input for the temperature input LB5*02 or FB5202 to process the millivolt signal for the resulting bridge voltage.

A constant current of 20 mA is sufficient for the bridge voltage for a 350 Ω bridge. A bridge voltage of 7 V is produced. With a bridge sensitivity of 2 mV/V, a voltage of 14 mV results at full load.



Configuring I/O Modules for Strain Gauge Measurement

1. Set a fixed value of 20 mA via the fieldbus for the analog output LB4101 or FB4*01.
2. Set the LB5*02 and FB5202 temperature input to a millivolt measurement.
3. Select an external cold junction for the temperature input LB5*02 or FB5202.
4. Deactivate cold junction compensation for LB5*02 and FB5202 temperature input by setting the thermostat temperature for the external cold junction to 0 °C.



Note!

Accuracy

The combination of the two I/O modules produces an overall accuracy of approx. 0.2 %. The accuracy is comprised as follows.

Current source LB4101 or FB4*01 equates to 0.1 %
millivolt amplifier LB5*02 or FB5202 PC equates to 0.1 %

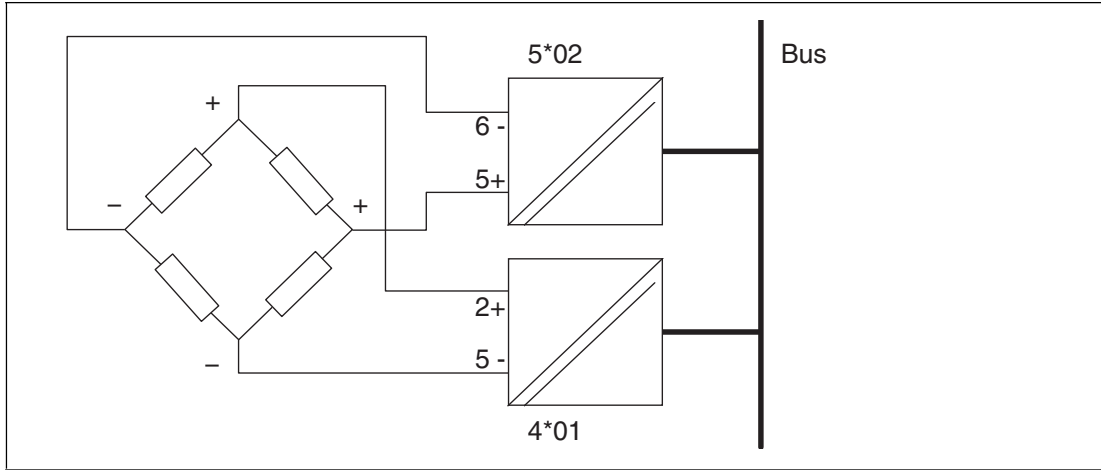

Figure 6.38 Example of a strain gauge bridge

6.21 LB5*04, FB5204 RTD Converter

6.21.1 Description

Versions

- LB5004, RTD converter, not intrinsically safe
- LB5104, RTD converter, intrinsically safe
- FB5204, RTD converter, intrinsically safe

Features

- Occupies 2 slots on the backplane
- Number of channels: 4
- Suitable sensors: 2-, 3- and 4-wire connection, resistance thermometer, slide-wire sensor

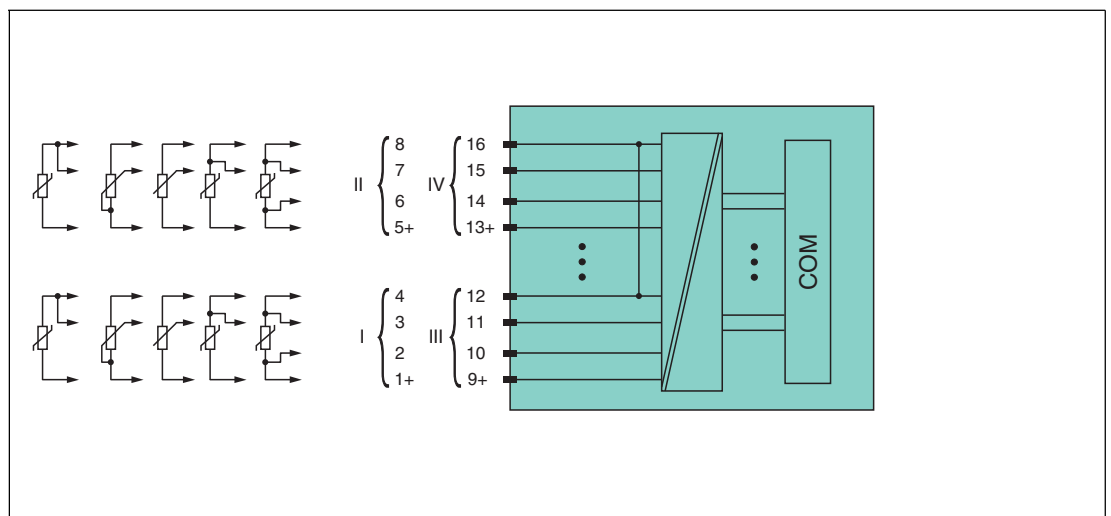

Figure 6.39 Block diagram LB5*04, FB5204

Channel I: resistance/potentiometer input 1 ... 4

Channel II: resistance/potentiometer input 5 ... 8

Channel III: resistance/potentiometer input 9 ... 12

Channel IV: resistance/potentiometer input 13 ... 16

Refer to the corresponding data sheet and operating instructions for further information.

6.21.2 Resolution

Temperatures within a range of -200 °C ... 850 °C are detected with a resolution of 16 bits. The actual measuring range is calculated based on this resolution.

For the smallest span (0 % ... 100 %), a resolution of 2500 measurement points is obtained, which corresponds to 0.04 %.

6.21.3 Measuring Time and Cycle Time

The processing times depend on the preset measurement process.

- 120 ms per active channel or 480 ms for all 4 channels
- 240 ms for converting the signals of a resistive sensor channel in a 3-wire configuration

The signals are transmitted to the com unit every 6.5 ms irrespective of the measuring time. It takes $4 \times 6.25 \text{ ms} = 25 \text{ ms}$ until the values of all 4 channels are present in the com unit because the values are transferred one after the other. This time must be added to the conversion time.

A filter is available for smoothing the input signals.

It can take 15 s after downloading a configuration before the I/O module parameters are applied.

6.21.4 Data Transfer

Data is transferred as specified in the PROFIBUS specification.

Successful PROFIBUS communication requires that the configuration, in particular the DP configuration string, in the master and the remote I/O station are identical. The configuration parameters are stored in the GSD/GSE file.

If the GSD/GSE file can be incorporated into the master, the DP configuration code for the relevant I/O module is copied automatically. If the GSD/GSE file cannot be incorporated, the configuration parameters must be entered in accordance with the table in this chapter. In addition to the GSD/GSE file, there are drivers available for further integration into various masters. The drivers provide the signals for the remote I/O station in processed format, meaning a manual integration of the I/O data in the data structures of the master is unnecessary.

The process data for each channel is transferred in unsigned integers within a range from 0 ... 65,535.

A data word (=16 bit) is available for each channel for the data transfer. The least significant 4 bits are of little importance for the accuracy of the measured value and are therefore used for transferring status information.



Note!

Dual-Width I/O Module

Dual-width I/O modules occupy two slots. Therefore, always configure an empty slot after this I/O module unless it is the last I/O module in a Remote I/O station. See chapter 6.1

Bit Structure within the Data Telegram

DP configuration code 53		
Byte	Bit	Description
Input byte 1 (low byte)	0	Empty
	1	Line fault detection channel 1 (0 = OK, 1 = error)
	2 ... 3	Empty
	4 ... 7	Measured value channel 1 (12 bit)
Input byte 2 (high byte)	0 ... 7	
Input bytes 3 ... 8		Same structure as input bytes 1 and 2 for channel 1
Output bytes		Without output bytes

6.21.5 Line Fault Detection

The line fault detection can detect a lead breakage or short circuit and can be switched off on a channel-by-channel basis.

- Line breakage: Resistance > 1 kΩ with Pt100
- Short circuit: Resistance < 10 Ω with Pt100

The broken wire delay function waits until 10 faultless measuring cycles have been completed before enabling measured values to avoid constant toggling between OK/fault if there is a loose contact.

6.21.6 Editing Device Data

All I/O module parameters that can be configured via the PROFIBUS class 1 master are listed below. See chapter 4

If the PROFIBUS class 1 master is not yet ready for operation, e.g., during partial commissioning, the remote I/O station can be configured with the help of the DTM and an external FDT framework application such as PACTware™. See chapter 5

If you are operating a master that has drivers or libraries, you do not need to worry about the octet strings. You only need to enter the relevant parameters.

All parameters are valid for each channel.

DP configuration string: 0x53

parameter string: 0x54, data_1, data_2, ..., data_8

Data_1, 3, 5, 7 (channel 1 ... channel 4)

Bit	Parameters	Selection
0	Line fault detection	0 = off 1 = on
1 ... 2	Analog filter	0 = off 1 = 100 %/s 2 = 10 %/s 3 = 1 %/s
3 ... 4	Operating mode	0 = 4-wire 1 = 3-wire 2 = 2-wire (RI = 20 Ω)
5 ... 7	-	-

Data_2, 4, 6, 8 (channel 1 ... channel 4)

Bit	Parameters	Selection
0 ... 7	Measurement range	<p>Pt100 0 = 0 ... 50 °C 1 = 0 ... 100 °C 2 = 0 ... 200 °C 3 = 0 ... 500 °C 4 = -200 ... 850 °C 5 = -200 ... 300 °C 6 = 300 ... 850 °C</p> <p>Pt200 10 = 0 ... 50 °C ... (such as Pt100) 16 = 300 ... 850 °C</p> <p>Pt500 20 = 0 ... 50 °C ... (such as Pt100) 26 = 300 ... 850 °C</p> <p>Pt1000 30 = 0 ... 50 °C ... (such as Pt100) 36 = 300 ... 850 °C</p> <p>Ni100 40 = 0 ... 50 °C 41 = 0 ... 100 °C 42 = 0 ... 150 °C 43 = 0 ... 200 °C 44 = -50 ... 50 °C 45 = -50 ... 150 °C 46 = -70 ... 230 °C</p> <p>Ni500 50 = 0 ... 50 °C ... (such as Ni100) 56 = -70 ... 230 °C</p> <p>Ni1000 60 = 0 ... 50 °C ... (such as Ni100) 66 = -70 ... 230 °C</p> <p>Slide-wire sensor, 2-wire see GSD/GSE file</p> <p>Slide-wire sensor, 3-wire see GSD/GSE file</p>

Line fault detection

Activate line fault detection to monitor the connection at the field end. In the event of a fault (e.g., lead breakage or short circuit), corresponding diagnostics are transmitted.

Analog filter

The analog filter for damping the signal can be activated if the input signals fluctuate. The value defines the rate of change of the input value in % per second. On the slowest setting of 1 %/s, it takes 90 seconds for a 90 % modification of the input signal to pass through the filter completely. The measurement range is used as the reference value (characteristic: ramp, linear).

Operating mode

Specify how the sensor is connected (2, 3 or 4-wire configuration). With a 2-wire configuration, the resistance of the supply lines is preset permanently to $RI = 20 \Omega$.

Measurement range

Select the correct measurement range in line with the connected sensor. The physical units differ depending on the sensor.

200337 2016-03

Preferred Parameter Values

Parameters	Values
Line fault detection	Off
Analog filter	Off
Operating mode	4-wire
Measurement range	Pt100: -200 °C ... 850 °C

6.22 LB5*05, FB5205 Thermocouple Converter

6.22.1 Description

Versions

- LB5005, thermocouple converter, not intrinsically safe
- LB5105, thermocouple converter, intrinsically safe
- FB5205, thermocouple converter, intrinsically safe

Features

- Occupies 2 slots on the backplane
- Number of channels: 4
- Suitable sensors: thermocouple types U, B, E, T, K, S, R, L, J, N, pallaplat and mV sensors

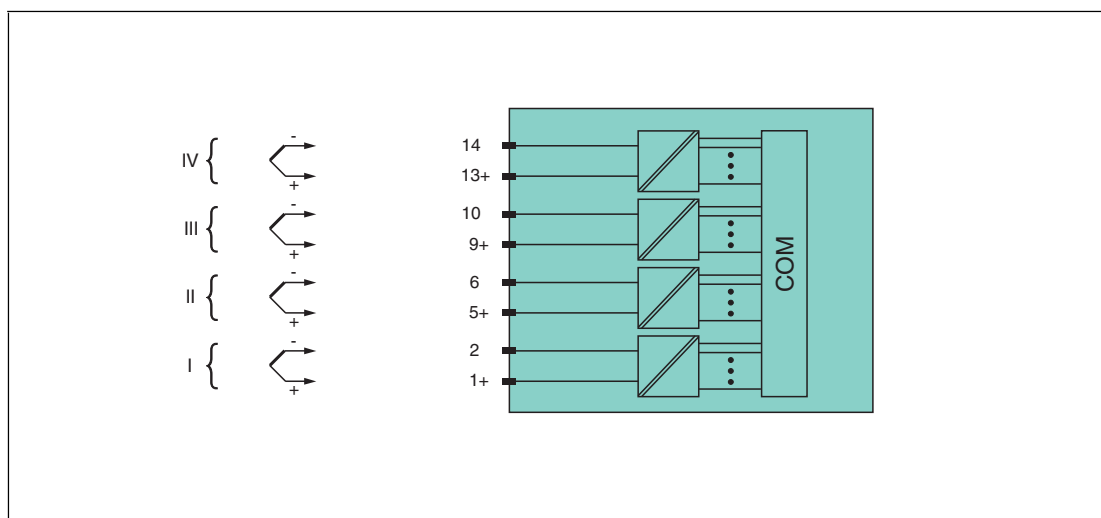

Figure 6.40 Block diagram LB5*05, FB5205

Channel I: 1+, 2-; channel II: 5+, 6-; channel III: 9+, 10-; channel IV: 13+, 14-

Refer to the corresponding data sheet and operating instructions for further information.

6.22.2 Resolution

Temperatures within a range of -200 °C ... 850 °C are detected with a resolution of 16 bits. The actual measuring range is calculated based on this resolution.

For the smallest span of 5 mV (0 % ... 100 %), a resolution of 2500 measurement points is obtained, which corresponds to 0.04 %.

All conventional thermocouple curves and pallaplat are linearized.

6.22.3 Measuring Time and Cycle Time

The processing times depend on the preset measurement process.

- 200 ms for all 4 channels without line fault detection (int./ext. cold junction)
- 350 ms for all 4 channels with line fault detection (int./ext. cold junction)

The signals are transmitted to the com unit every 6.5 ms irrespective of the measuring time. It takes $4 \times 6.25 \text{ ms} = 25 \text{ ms}$ until the values of all 4 channels are present in the com unit because the values are transferred one after the other. This time must be added to the conversion time.

A filter is available for smoothing the input signals.

6.22.4 Data Transfer

Data is transferred as specified in the PROFIBUS specification.

Successful PROFIBUS communication requires that the configuration, in particular the DP configuration string, in the master and the remote I/O station are identical. The configuration parameters are stored in the GSD/GSE file.

If the GSD/GSE file can be incorporated into the master, the DP configuration code for the relevant I/O module is copied automatically. If the GSD/GSE file cannot be incorporated, the configuration parameters must be entered in accordance with the table in this chapter. In addition to the GSD/GSE file, there are drivers available for further integration into various masters. The drivers provide the signals for the remote I/O station in processed format, meaning a manual integration of the I/O data in the data structures of the master is unnecessary.

The process data for each channel is transferred in unsigned integers within a range from 0 ... 65,535.

A data word (=16 bit) is available for each channel for the data transfer. The least significant 4 bits are of little importance for the accuracy of the measured value and are therefore used for transferring status information.



Note!

Dual-Width I/O Module

Dual-width I/O modules occupy two slots. Therefore, always configure an empty slot after this I/O module unless it is the last I/O module in a Remote I/O station. See chapter 6.1

Bit Structure within the Data Telegram

DP configuration code 53		
Byte	Bit	Description
Input byte 1 (low byte)	0	Empty
	1	Line fault detection channel 1 (0 = OK, 1 = error)
	2 ... 3	Empty
	4 ... 7	Measured value channel 1 (12 bit)
Input byte 2 (high byte)	0 ... 7	
Input bytes 3 ... 8		Same structure as input bytes 1 and 2 for channel 1
Output bytes		Without output bytes

6.22.5 Line Fault Detection

The line fault detection can detect a line breakage and can be disabled via software.

The broken wire delay function waits until 10 faultless cycles have been completed before enabling measured values to avoid constant toggling between OK/fault if there is a loose contact.

6.22.6 Editing Device Data

All I/O module parameters that can be configured via the PROFIBUS class 1 master are listed below. See chapter 4

If the PROFIBUS class 1 master is not yet ready for operation, e.g., during partial commissioning, the remote I/O station can be configured with the help of the DTM and an external FDT framework application such as PACTware™. See chapter 5

If you are operating a master that has drivers or libraries, you do not need to worry about the octet strings. You only need to enter the relevant parameters.

All parameters are valid for each channel.

DP configuration string: 0x53
parameter string: 0x55, data_1, data_2, ..., data_8

Data_1, 3, 5, 7 (channel 1 ... channel 4)

Bit	Parameters	Selection
0	Line fault detection	0 = off 1 = on
1 ... 2	Analog filter	0 = off 1 = 100 %/s 2 = 10 %/s 3 = 1 %/s
3	Cold junction	0 = internal 1 = external
4	Ext. cold junction temperature	0 = 0 °C 1 = 50 °C
5 ... 7	-	-

Data_2, 4, 6, 8 (channel 1 ... channel 4)

Bit	Parameters	Selection
0 ... 5	Measurement range	mV 0 = -65 ... 75 mV 1 = 0 ... 75 mV 2 = 0 ... 50 mV 3 = 0 ... 25 mV Type U 4 = -200 ... 600 °C 5 = -200 ... 200 °C 6 = 0 ... 200 °C 7 = 200 ... 600 °C Type B 8 = 0 ... 1800 °C 9 = 0 ... 900 °C 10 = 450 ... 1350 °C 11 = 900 ... 1800 °C Type E 12 = -270 ... 1000 °C 13 = -270 ... 360 °C 14 = 50 ... 680 °C 15 = 360 ... 1000 °C Type T 16 = -270 ... 400 °C 17 = -270 ... 60 °C 18 = -100 ... 230 °C 19 = 60 ... 400 °C Type K 20 = -200 ... 1370 °C 21 = -200 ... 500 °C 22 = 150 ... 850 °C 23 = 500 ... 1370 °C Type S 24 = 0 ... 1760 °C 25 = 0 ... 900 °C 26 = 450 ... 1350 °C 27 = 900 ... 1760 °C Type R 28 = -50 ... 1750 °C 29 = -50 ... 900 °C 30 = 450 ... 1350 °C 31 = 900 ... 1750 °C Type L 32 = -200 ... 900 °C 33 = -200 ... 350 °C 34 = 75 ... 625 °C 35 = 350 ... 900 °C Type J 36 = -210 ... 1200 °C 37 = -200 ... 500 °C 38 = 150 ... 850 °C 39 = 500 ... 1200 °C Type N 40 = -200 ... 1350 °C 41 = -200 ... 600 °C 42 = 200 ... 1000 °C 43 = 500 ... 1350 °C Pallaplat 44 = -100 ... 1300 °C 45 = -100 ... 600 °C 46 = 250 ... 950 °C 47 = 600 ... 1300 °C
6 ... 7	-	-

200337 2016-03

Line fault detection

Activate line fault detection to monitor the connection at the field end. In the event of a fault (e.g., lead breakage or short circuit), corresponding diagnostics are transmitted.

Analog filter

The analog filter for damping the signal can be activated if the input signals fluctuate. The value defines the rate of change of the input value in % per second. On the slowest setting of 1 %/s, it takes 90 seconds for a 90 % modification of the input signal to pass through the filter completely. The measurement range is used as the reference value (characteristic: ramp, linear).

Cold junction

Select between an internal and external cold junction. If you have selected an external cold junction, specify the external cold junction temperature.



Note!

Internal cold junction fitted

The cold junction is installed permanently for I/O modules LB5*05 and FB5205. It measures the temperature at the terminals inside the I/O module.

Ext. cold junction temperature

If you have selected an external cold junction, specify the temperature of the thermostat in use.

Measurement range

Select the correct measurement range in line with the connected sensor. The physical units differ depending on the sensor.

Preferred Parameter Values

Parameters	Values
Line fault detection	Off
Analog filter	Off
Cold junction	Internal
Ext. cold junction temperature	0 °C
Measurement range	Type U: -200 °C ... 600 °C

6.23 LB5*06, FB5206 Voltage Converter

6.23.1 Description

Versions

- LB5006, voltage converter, not intrinsically safe
- LB5106, voltage converter, intrinsically safe
- FB5206, voltage converter, intrinsically safe

Features

- Occupies 1 slot on the backplane
- Number of channels: 1
- Input 0 V ... 10 V

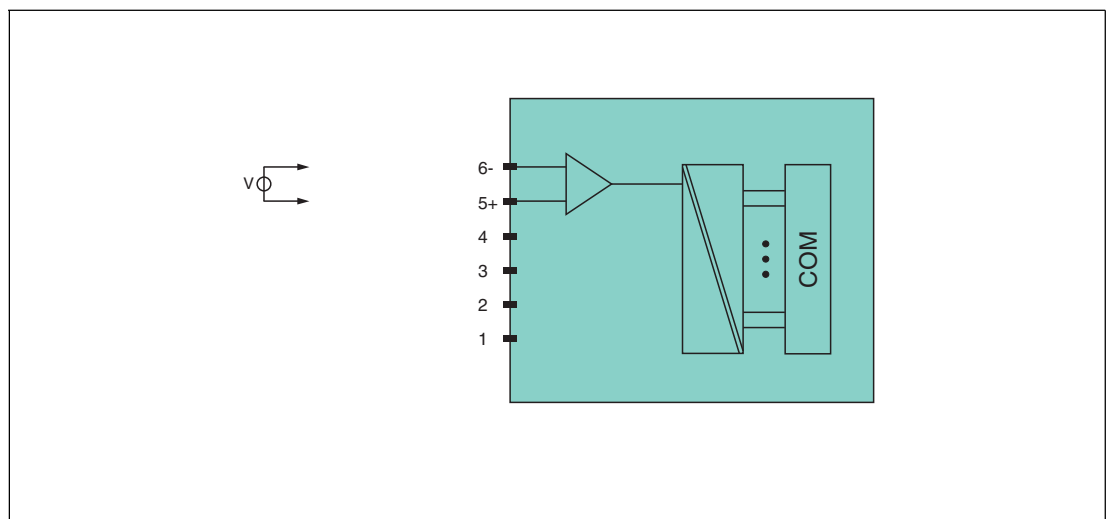

Figure 6.41 Block diagram LB5*06, FB5206

Refer to the corresponding data sheet and operating instructions for further information.

6.23.2 Resolution

Voltages within a range of 0 V ... 10 V are detected with a resolution of 16 bits. The actual measuring range is calculated based on this resolution. For the smallest span of 100 mV (0 ... 100 %) a resolution of 2500 measurement points is obtained, which corresponds to a degree of accuracy of 0.04%.

6.23.3 Measuring Time and Cycle Time

The internal module processing time is 100 ms.

The signals are transmitted to the com unit every 6.5 ms irrespective of the measuring time. A filter is available for smoothing the input signals.

6.23.4 Data Transfer

Data is transferred as specified in the PROFIBUS specification.

Successful PROFIBUS communication requires that the configuration, in particular the DP configuration string, in the master and the remote I/O station are identical. The configuration parameters are stored in the GSD/GSE file.

If the GSD/GSE file can be incorporated into the master, the DP configuration code for the relevant I/O module is copied automatically. If the GSD/GSE file cannot be incorporated, the configuration parameters must be entered in accordance with the table in this chapter. In addition to the GSD/GSE file, there are drivers available for further integration into various masters. The drivers provide the signals for the remote I/O station in processed format, meaning a manual integration of the I/O data in the data structures of the master is unnecessary.

The process data for each channel is transferred in unsigned integers within a range from 0 ... 65535.

One data word (16 bit) word per channel is available for data transfer. The most significant 12 bits are used.

Bit Structure within the Data Telegram

DP configuration code 50		
Byte	Bit	Description
Input byte 1 (low byte)	0 ... 3	Empty
	4 ... 7	Measured value (12 bit)
Input byte 2 (high byte)	0 ... 7	
Output bytes		Without output bytes

6.23.5 Line Fault Detection

The I/O module does not provide any line fault detection function.

6.23.6 Editing Device Data

All I/O module parameters that can be configured via the PROFIBUS class 1 master are listed below. See chapter 4

If the PROFIBUS class 1 master is not yet ready for operation, e.g., during partial commissioning, the remote I/O station can be configured with the help of the DTM and an external FDT framework application such as PACTware™. See chapter 5

If you are operating a master that has drivers or libraries, you do not need to worry about the octet strings. You only need to enter the relevant parameters.

All parameters are valid for each channel.

DP configuration string: 0x50
parameter string: 0x56, data_1, data_2

Data_1

Bit	Parameters	Selection
0	-	-
1 ... 2	Analog filter	0 = off 1 = 100 %/s 2 = 10 %/s 3 = 1 %/s
3 ... 7	-	-

Data_2

Bit	Parameters	Selection
0 ... 4	Measurement range	0 = 0 ... 10 V 1 = 0 ... 5 V 2 = 0 ... 2 V 3 = 0 ... 1 V
5 ... 7	-	-

Analog filter

The analog filter for damping the signal can be activated if the input signals fluctuate. The value defines the rate of change of the input value in % per second. On the slowest setting of 1 %/s, it takes 90 seconds for a 90 % modification of the input signal to pass through the filter completely. The measurement range is used as the reference value (characteristic: ramp, linear).

Measurement range

Select the required measurement range for the connected sensor.

Preferred Parameter Values

Parameters	Values
Analog filter	Off
Measurement range	0 V ... 10 V

6.24 LB6101, FB6301 Relay Contact Output

6.24.1 Description

Versions

- LB6101, relay contact output, not intrinsically safe
- FB6301, relay contact output, wire ends for connection to separate increased safety terminal

Features

- Occupies 1 slot on the backplane
- Number of channels: 2
- LB6101
 - Switching voltage: 24 VDC/VAC (30 V max.)/230 VAC, 60 V (UL)
 - Switching current: 1 ADC/AAC resistive load
 - Switching power: 30 VA/30 W/230 VA, 60 W (UL)
- FB6301
 - Switching voltage: 24 VDC/230 VAC
 - Switching current: 1 ADC/AAC resistive load
 - Switching power: 30 W, 230 VA resistive load

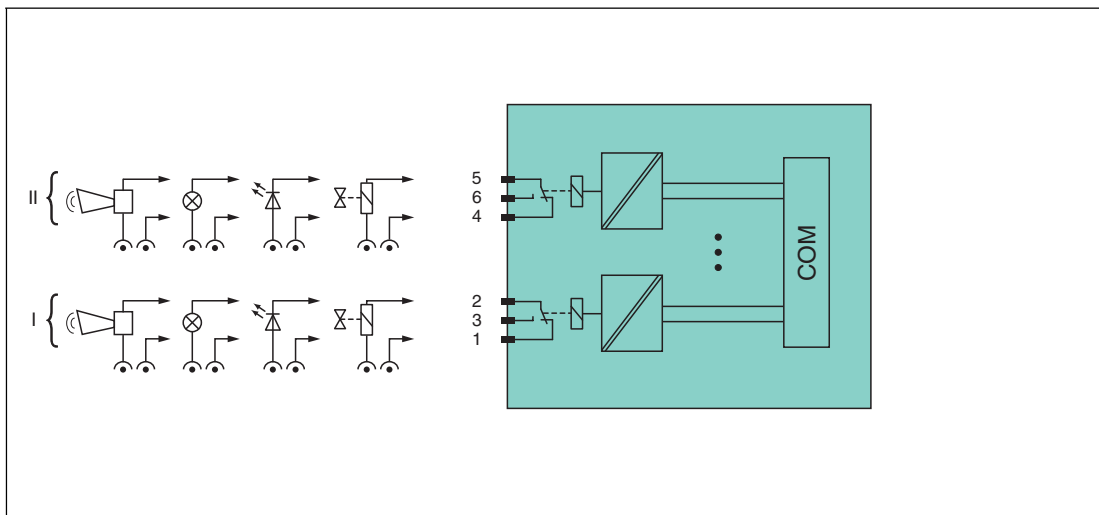

Figure 6.42 Block diagram LB6101, FB6301

LB6101: channel I: 1-2 NC, 3; channel II: 4-5 NC, 6

FB6301: wire ends 1 (white), 2 (brown), 3 (green), 4 (yellow), 5 (gray), 6 (pink), observe color marking or numbering

Refer to the corresponding data sheet and operating instructions for further information.

6.24.2 Measuring Time and Cycle Time

The response time of the relay output is 20 ms. However, this time depends on the cycle time of the data traffic on the bus.

The signals are transmitted to the com unit every 6.5 ms irrespective of the measuring time.

6.24.3 Data Transfer

Data is transferred as specified in the PROFIBUS specification.

Successful PROFIBUS communication requires that the configuration, in particular the DP configuration string, in the master and the remote I/O station are identical. The configuration parameters are stored in the GSD/GSE file.

If the GSD/GSE file can be incorporated into the master, the DP configuration code for the relevant I/O module is copied automatically. If the GSD/GSE file cannot be incorporated, the configuration parameters must be entered in accordance with the table in this chapter. In addition to the GSD/GSE file, there are drivers available for further integration into various masters. The drivers provide the signals for the remote I/O station in processed format, meaning a manual integration of the I/O data in the data structures of the master is unnecessary.

Bit Structure within the Data Telegram

DP configuration code 20		
Byte	Bit	Description
Input bytes		Without input bytes
Output byte 1	0	Output channel 1
	1	Output channel 2
	2 ... 7	Empty

6.24.4 Line Fault Detection

The I/O module does not provide any line fault detection function.

6.24.5 Watchdog

The I/O module has a watchdog function. If the communication between the I/O module and com unit stops, the I/O module enters the safe state after 0.5 s.

6.24.6 Editing Device Data

All I/O module parameters that can be configured via the PROFIBUS class 1 master are listed below. See chapter 4

If the PROFIBUS class 1 master is not yet ready for operation, e.g., during partial commissioning, the remote I/O station can be configured with the help of the DTM and an external FDT framework application such as PACTware™. See chapter 5

If you are operating a master that has drivers or libraries, you do not need to worry about the octet strings. You only need to enter the relevant parameters.

All parameters are valid for each channel.

DP configuration string: 0x20

parameter string: 0x61, data_1, data_2

Data_1, data_2 (channel 1, channel 2)

Bit	Parameters	Selection
0	-	-
1	Inverter	0 = off 1 = on
2 ... 3	Substitute value	0 = logical 0 1 = logical 1 2 = current value
4 ... 7	-	-



Inverter

Choose between positive or negative logic for the digital signal.

Substitute value

The I/O module may issue substitute values in the event of an error. See chapter 6.2

Preferred Parameter Values

Parameters	Values
Inverter	Off
Substitute value	Off

6.25 LB6005, FB6305 Relay Contact Output

6.25.1 Description

Versions

- LB6005, relay contact output, not intrinsically safe
- FB6305, relay contact output, wire ends for connection to separate increased safety terminal

Features

- Occupies 2 slots on the backplane
- Number of channels: 4
- LB6005
 - Switching voltage: DC: 30 V, AC: 230 V, 60 V (UL)
 - Switching current: 1 ADC/AAC resistive load
 - Switching power: 30 W, AC: 250 VA , 60 W (UL)
- FB6305
 - Switching voltage: DC: 30 V, AC: 230 V
 - Switching current: 1 ADC/AAC resistive load
 - Switching power: 30 W, AC: 250 VA

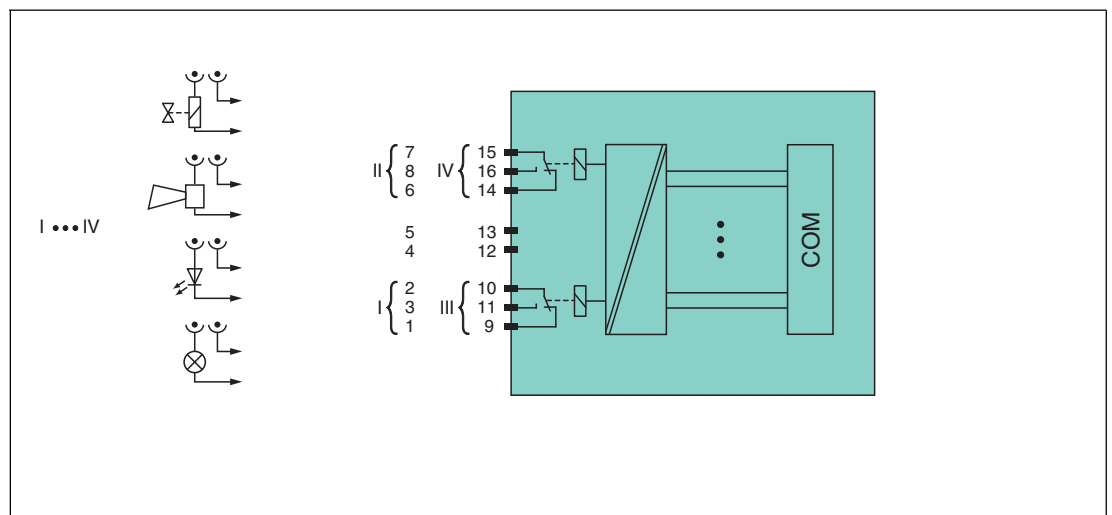

Figure 6.43 Block diagram LB6005, FB6305

LB6005: channel I: 1-2 NC, 3; channel II: 6-7 NC, 8; channel III: 9-10 NC, 11; channel IV: 14-15 NC, 16

FB6305: wire ends 1/9 (white), 2/10 (brown), 3/11 (green), 4/12 (yellow), 5/13 (gray), 6/14 (pink), 7/15 (blue), 8/16 (red), observe color marking or numbering

Refer to the corresponding data sheet and operating instructions for further information.

6.25.2 Measuring Time and Cycle Time

The response time of the relay output is 20 ms. However, this time depends on the cycle time of the data traffic on the bus.

The signals are transmitted to the com unit every 6.5 ms irrespective of the measuring time.

6.25.3 Data Transfer

Data is transferred as specified in the PROFIBUS specification.

Successful PROFIBUS communication requires that the configuration, in particular the DP configuration string, in the master and the remote I/O station are identical. The configuration parameters are stored in the GSD/GSE file.

If the GSD/GSE file can be incorporated into the master, the DP configuration code for the relevant I/O module is copied automatically. If the GSD/GSE file cannot be incorporated, the configuration parameters must be entered in accordance with the table in this chapter. In addition to the GSD/GSE file, there are drivers available for further integration into various masters. The drivers provide the signals for the remote I/O station in processed format, meaning a manual integration of the I/O data in the data structures of the master is unnecessary.

Input and Output Data

The I/O module has input and output data.

The output data sets the control outputs and marks the data as valid or invalid. As soon as the **data invalid** error bit is set, the substitute values are used.

The input data allows the master to retrieve the current output status.



Note!

Dual-Width I/O Module

Dual-width I/O modules occupy two slots. Therefore, always configure an empty slot after this I/O module unless it is the last I/O module in a Remote I/O station. See chapter 6.1

Bit Structure within the Data Telegram

DP configuration code 30		
Byte	Bit	Description
Input byte 1	0	Output status channel 1
	1	Empty
	2	Output status channel 2
	3	Empty
	4	Output status channel 3
	5	Empty
	6	Output status channel 4
	7	Empty
Output byte 1	0	Output channel 1
	1	Channel 1 = 0 enabled, 1 = invalid
	2	Output channel 2
	3	Channel 2 = 0 enabled, 1 = invalid
	4	Output channel 3
	5	Channel 3 = 0 enabled, 1 = invalid
	6	Output channel 4
	7	Channel 4 = 0 enabled, 1 = invalid

6.25.4 Line Fault Detection

The I/O module does not provide any line fault detection function.

6.25.5 Watchdog

The I/O module has a watchdog function. If the communication between the I/O module and com unit stops, the I/O module enters the safe state after 0.5 s.

6.25.6 Editing Device Data

All I/O module parameters that can be configured via the PROFIBUS class 1 master are listed below. See chapter 4

If the PROFIBUS class 1 master is not yet ready for operation, e.g., during partial commissioning, the remote I/O station can be configured with the help of the DTM and an external FDT framework application such as PACTware™. See chapter 5

If you are operating a master that has drivers or libraries, you do not need to worry about the octet strings. You only need to enter the relevant parameters.

All parameters are valid for each channel.

DP configuration string: 0x30

parameter string: 0x65, data_1, ..., data_4

Data_1 ... data_4 (channel 1 ... channel 4)

Bit	Parameters	Selection
0	-	-
1	Inverter	0 = off 1 = on
2 ... 3	Substitute value	0 = logical 0 1 = logical 1 2 = current value
4 ... 7	-	-

Inverter

Choose between positive or negative logic for the digital signal.

Substitute value

The I/O module may issue substitute values in the event of an error. See chapter 6.2

Preferred Parameter Values

Parameters	Values
Inverter	Off
Substitute value	Off

6.26 LB6006, FB6306 Relay Contact Output

6.26.1 Description

Versions

- LB6006, relay contact output, not intrinsically safe
- FB6306, relay contact output, increased safety terminals

Features

- Occupies 2 slots on the backplane
- Number of channels: 8
- Switching voltage: 24 VDC/VAC
- Switching current: 1 ADC/AAC resistive load
- Switching power: 30 VA/30 W

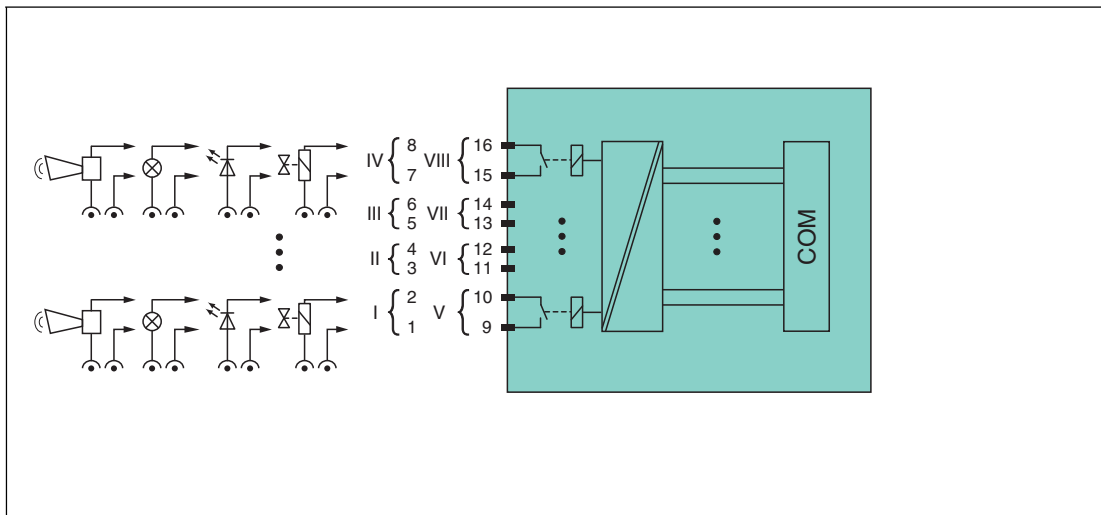

Figure 6.44 Block diagram LB6006, FB6306

Connection: channel I: 1-2 NO; channel II: 3-4 NO; channel III: 5-6 NO; channel IV: 7-8 NO; channel V: 9-10 NO; channel VI: 11-12 NO; channel VII: 13-14 NO; channel VIII: 15-16 NO

Refer to the corresponding data sheet and operating instructions for further information.

6.26.2 Measuring Time and Cycle Time

The response time of the relay output is 20 ms. However, this time depends on the cycle time of the data traffic on the bus.

The signals are transmitted to the com unit every 6.5 ms irrespective of the measuring time.

6.26.3 Data Transfer

Data is transferred as specified in the PROFIBUS specification.

Successful PROFIBUS communication requires that the configuration, in particular the DP configuration string, in the master and the remote I/O station are identical. The configuration parameters are stored in the GSD/GSE file.

If the GSD/GSE file can be incorporated into the master, the DP configuration code for the relevant I/O module is copied automatically. If the GSD/GSE file cannot be incorporated, the configuration parameters must be entered in accordance with the table in this chapter. In addition to the GSD/GSE file, there are drivers available for further integration into various masters. The drivers provide the signals for the remote I/O station in processed format, meaning a manual integration of the I/O data in the data structures of the master is unnecessary.

Input and Output Data

The I/O module has input and output data.

The output data sets the control outputs and marks the data as valid or invalid. As soon as the **data invalid** error bit is set, the substitute values are used.

The input data allows the master to retrieve the current output status.



Note!

Dual-Width I/O Module

Dual-width I/O modules occupy two slots. Therefore, always configure an empty slot after this I/O module unless it is the last I/O module in a Remote I/O station. See chapter 6.1

Bit Structure within the Data Telegram

DP configuration code 31		
Byte	Bit	Description
Input byte 1	0	Output status channel 5
	1	Empty
	2	Output status channel 6
	3	Empty
	4	Output status channel 7
	5	Empty
	6	Output status channel 8
	7	Empty
Input byte 2	0	Output status channel 1
	1	Empty
	2	Output status channel 2
	3	Empty
	4	Output status channel 3
	5	Empty
	6	Output status channel 4
	7	Empty
Output byte 1	0	Output channel 5
	1	Channel 5 = 0 enabled, 1 = invalid
	2	Output channel 6
	3	Channel 6 = 0 enabled, 1 = invalid
	4	Output channel 7
	5	Channel 7 = 0 enabled, 1 = invalid
	6	Output channel 8
	7	Channel 8 = 0 enabled, 1 = invalid

DP configuration code 31		
Byte	Bit	Description
Output byte 2	0	Output channel 1
	1	Channel 1 = 0 enabled, 1 = invalid
	2	Output channel 2
	3	Channel 2 = 0 enabled, 1 = invalid
	4	Output channel 3
	5	Channel 3 = 0 enabled, 1 = invalid
	6	Output channel 4
	7	Channel 4 = 0 enabled, 1 = invalid

6.26.4 Line Fault Detection

The I/O module does not provide any line fault detection function.

6.26.5 Watchdog

The I/O module has a watchdog function. If the communication between the I/O module and com unit stops, the I/O module enters the safe state after 0.5 s.

6.26.6 Editing Device Data

All I/O module parameters that can be configured via the PROFIBUS class 1 master are listed below. See chapter 4

If the PROFIBUS class 1 master is not yet ready for operation, e.g., during partial commissioning, the remote I/O station can be configured with the help of the DTM and an external FDT framework application such as PACTware™. See chapter 5

If you are operating a master that has drivers or libraries, you do not need to worry about the octet strings. You only need to enter the relevant parameters.

All parameters are valid for each channel.

DP configuration string: 0x31
parameter string: 0x66, data_1, ..., data_8

Data_1 ... data_8 (channel 1 ... channel 8)

Bit	Parameters	Selection
0	-	-
1	Inverter	0 = off 1 = on
2 ... 3	Substitute value	0 = logical 0 1 = logical 1 2 = current value
4 ... 7	-	-

Inverter

Choose between positive or negative logic for the digital signal.

Substitute value

The I/O module may issue substitute values in the event of an error. See chapter 6.2



Preferred Parameter Values

Parameters	Values
Inverter	Off
Substitute value	Off

6.27 LB6*08, FB6*08 Digital Output

6.27.1 Description

Versions

- LB6008, digital output, not intrinsically safe
Versions available with bus-independent shutdown input
- FB6308, digital output with shutdown input, increased safety terminals
- LB6108, digital output with shutdown input, intrinsically safe
- FB6208, digital output with shutdown input, intrinsically safe

Features

- Occupies 2 slots on the backplane
- Number of channels: 8
- Switching capacity: 20 VDC/8 mA

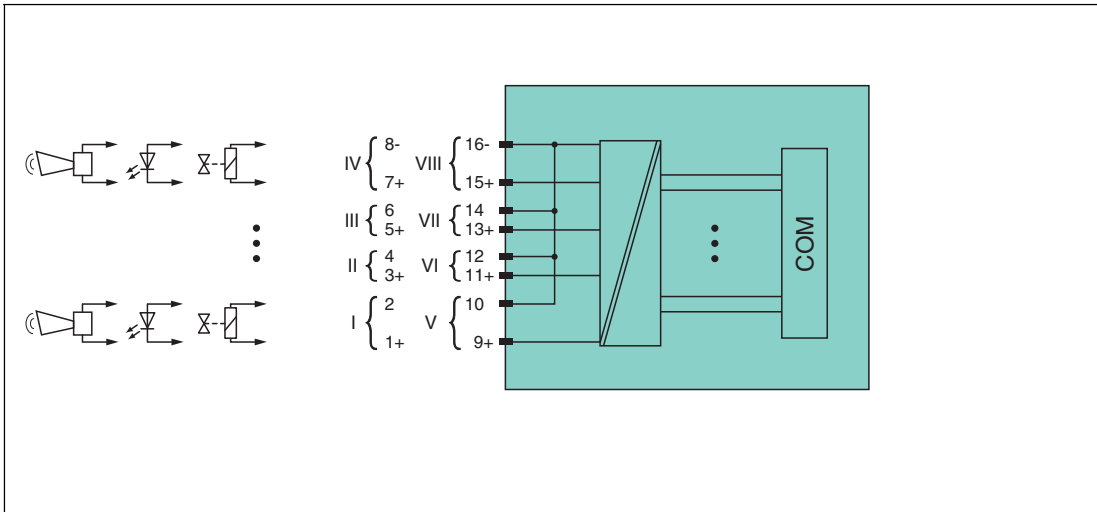

Figure 6.45 Block diagram LB6*08 without shutdown input

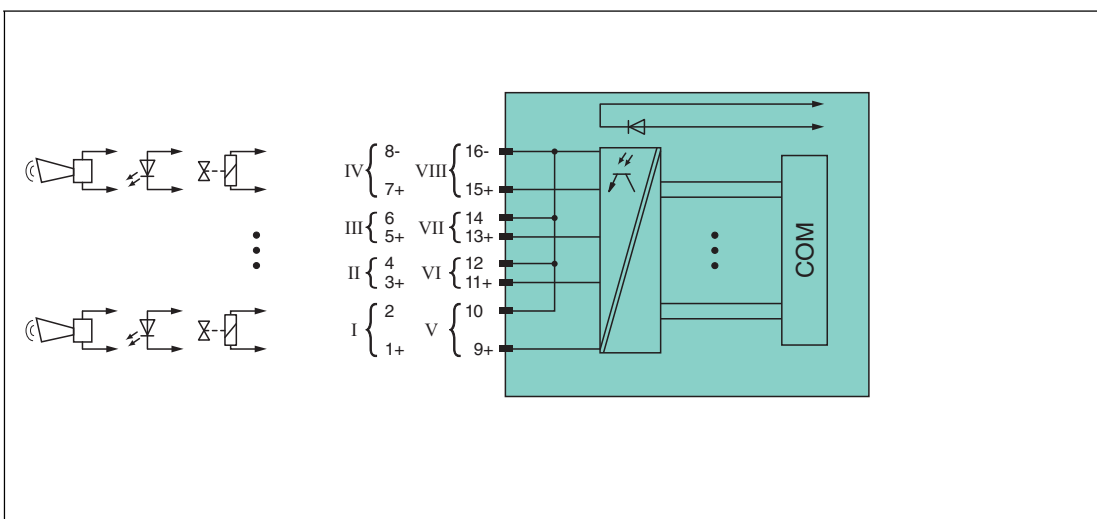

Figure 6.46 Block diagram LB6*08, FB6*08 with shutdown input

Refer to the corresponding data sheet and operating instructions for further information.

6.27.2 Measuring Time and Cycle Time

The response time of the digital output is 10 ms. However, this time depends on the cycle time of the data traffic on the bus.

The signals are transmitted to the com unit every 6.5 ms irrespective of the measuring time.

6.27.3 Data Transfer

Data is transferred as specified in the PROFIBUS specification.

Successful PROFIBUS communication requires that the configuration, in particular the DP configuration string, in the master and the remote I/O station are identical. The configuration parameters are stored in the GSD/GSE file.

If the GSD/GSE file can be incorporated into the master, the DP configuration code for the relevant I/O module is copied automatically. If the GSD/GSE file cannot be incorporated, the configuration parameters must be entered in accordance with the table in this chapter. In addition to the GSD/GSE file, there are drivers available for further integration into various masters. The drivers provide the signals for the remote I/O station in processed format, meaning a manual integration of the I/O data in the data structures of the master is unnecessary.

Input and Output Data

The I/O module has input and output data.

The output data sets the control outputs and marks the data as valid or invalid. As soon as the **data invalid** error bit is set, the substitute values are used.

The input data allows the master to retrieve the current output status.



Note!

Dual-Width I/O Module

Dual-width I/O modules occupy two slots. Therefore, always configure an empty slot after this I/O module unless it is the last I/O module in a Remote I/O station. See chapter 6.1

Bit Structure within the Data Telegram

DP configuration code 31		
Byte	Bit	Description
Input byte 1	0	Output status channel 5
	1	Line fault detection channel 5 (0 = OK, 1 = error)
	2	Output status channel 6
	3	Line fault detection channel 6 (0 = OK, 1 = error)
	4	Output status channel 7
	5	Line fault detection channel 7 (0 = OK, 1 = error)
	6	Output status channel 8
	7	Line fault detection channel 8 (0 = OK, 1 = error)

DP configuration code 31		
Byte	Bit	Description
Input byte 2	0	Output status channel 1
	1	Line fault detection channel 1 (0 = OK, 1 = error)
	2	Output status channel 2
	3	Line fault detection channel 2 (0 = OK, 1 = error)
	4	Output status channel 3
	5	Line fault detection channel 3 (0 = OK, 1 = error)
	6	Output status channel 4
	7	Line fault detection channel 4 (0 = OK, 1 = error)
Output byte 1	0	Output channel 5
	1	Channel 5 = 0 enabled, 1 = invalid
	2	Output channel 6
	3	Channel 6 = 0 enabled, 1 = invalid
	4	Output channel 7
	5	Channel 7 = 0 enabled, 1 = invalid
	6	Output channel 8
	7	Channel 8 = 0 enabled, 1 = invalid
Output byte 2	0	Output channel 1
	1	Channel 1 = 0 enabled, 1 = invalid
	2	Output channel 2
	3	Channel 2 = 0 enabled, 1 = invalid
	4	Output channel 3
	5	Channel 3 = 0 enabled, 1 = invalid
	6	Output channel 4
	7	Channel 4 = 0 enabled, 1 = invalid

6.27.4 Line Fault Detection

The I/O module has a line fault detection function that can detect lead breakages and short circuits. Line fault detection can be switched on and off in the device type manager.

The line fault detection function is based on the measurement of a trickle current so low that it does not activate a connected valve.

6.27.5 Watchdog

The I/O module has a watchdog function. If the communication between the I/O module and com unit stops, the I/O module enters the safe state after 0.5 s.

6.27.6 Editing Device Data

All I/O module parameters that can be configured via the PROFIBUS class 1 master are listed below. See chapter 4

If the PROFIBUS class 1 master is not yet ready for operation, e.g., during partial commissioning, the remote I/O station can be configured with the help of the DTM and an external FDT framework application such as PACTware™. See chapter 5

If you are operating a master that has drivers or libraries, you do not need to worry about the octet strings. You only need to enter the relevant parameters.

All parameters are valid for each channel.

DP configuration string: 0x31

parameter string: 0x68, data_1, data_2, ..., data_8

Data_1 ... data_8 (channel 1 ... channel 8)

Bit	Parameters	Selection
0	Line fault detection	0 = off 1 = on
1	Inverter	0 = off 1 = on
2 ... 3	Substitute value	0 = logical 0 1 = logical 1 2 = last valid value 3 = current value
4 ... 7	-	-

Line fault detection

Activate line fault detection to monitor the connection at the field end. In the event of a fault (e.g., lead breakage or short circuit), corresponding diagnostics are transmitted.

Inverter

Choose between positive or negative logic for the digital signal.

Substitute value

The I/O module may issue substitute values in the event of an error. See chapter 6.2

Preferred Parameter Values

Parameters	Values
Line fault detection	Off
Inverter	Off
Substitute value	Off

6.28 LB6*10 ... LB6115, FB6210 ... FB6215 Digital Output

6.28.1 Description

Versions

- LB6010, digital output, not intrinsically safe
Versions available with bus-independent shutdown input
- LB6110 ... LB6115, digital output, intrinsically safe
Versions available with bus-independent shutdown input
- FB6210 ... FB6215, digital output, intrinsically safe
Versions available with bus-independent shutdown input

Features

- Occupies 2 slots on the backplane
- Number of channels: 4
- The electrical data of the versions is different.

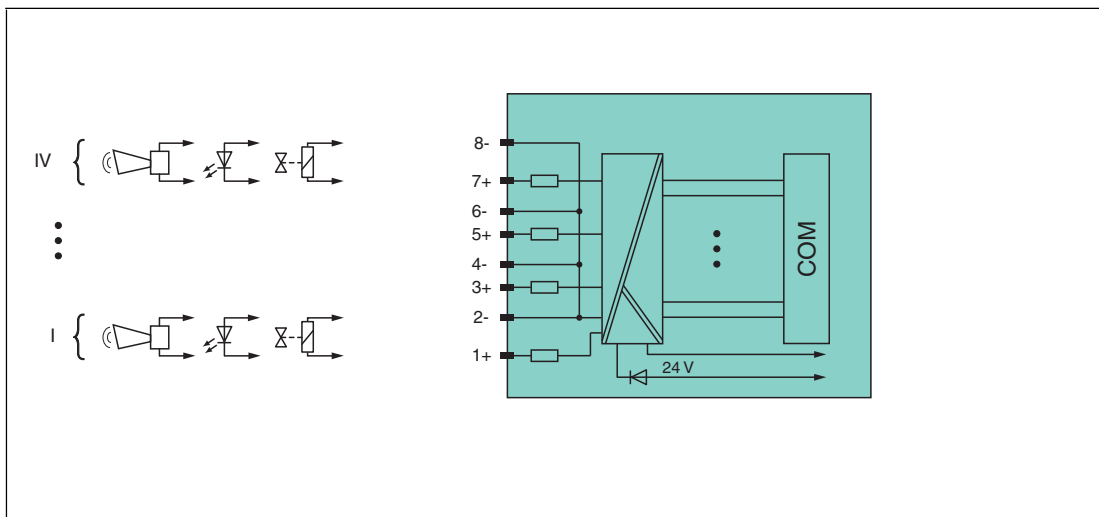
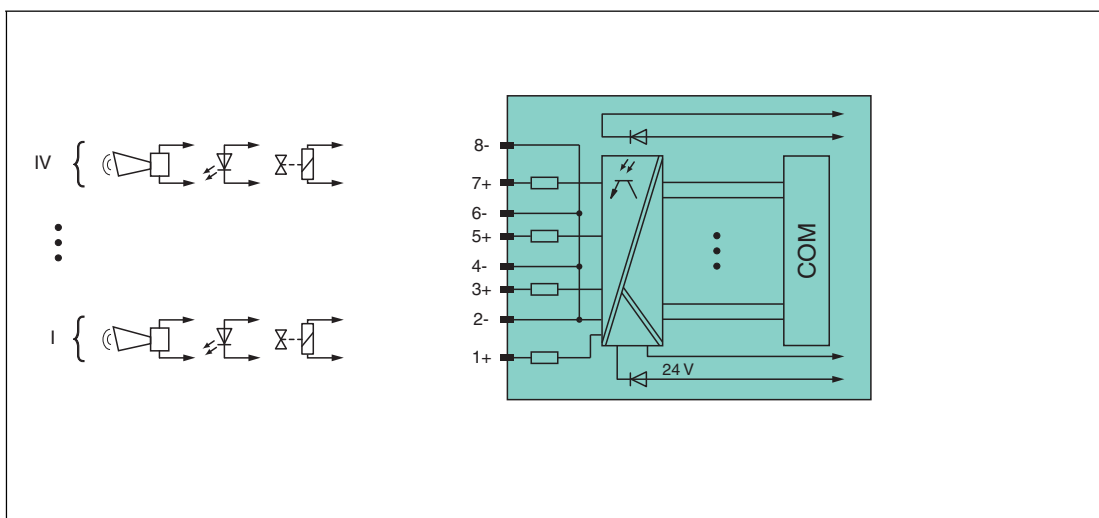

Figure 6.47 Block diagram LB6*1*, FB621* without shutdown input



Block diagram LB6*1*, FB621* with shutdown input

Refer to the corresponding data sheet and operating instructions for further information.

6.28.2 Measuring Time and Cycle Time

The response time of the digital output is 10 ms. However, this time depends on the cycle time of the data traffic on the bus.

The signals are transmitted to the com unit every 6.5 ms irrespective of the measuring time.

6.28.3 Data Transfer

Data is transferred as specified in the PROFIBUS specification.

Successful PROFIBUS communication requires that the configuration, in particular the DP configuration string, in the master and the remote I/O station are identical. The configuration parameters are stored in the GSD/GSE file.

If the GSD/GSE file can be incorporated into the master, the DP configuration code for the relevant I/O module is copied automatically. If the GSD/GSE file cannot be incorporated, the configuration parameters must be entered in accordance with the table in this chapter. In addition to the GSD/GSE file, there are drivers available for further integration into various masters. The drivers provide the signals for the remote I/O station in processed format, meaning a manual integration of the I/O data in the data structures of the master is unnecessary.

Input and Output Data

The I/O module has input and output data.

The output data sets the control outputs and marks the data as valid or invalid. As soon as the **data invalid** error bit is set, the substitute values are used.

The input data allows the master to retrieve the current output status.



Note!

Dual-Width I/O Module

Dual-width I/O modules occupy two slots. Therefore, always configure an empty slot after this I/O module unless it is the last I/O module in a Remote I/O station. See chapter 6.1

Bit Structure within the Data Telegram

DP configuration code 30		
Byte	Bit	Description
Input byte 1	0	Output status channel 1
	1	Line fault detection channel 1 (0 = OK, 1 = error)
	2	Output status channel 2
	3	Line fault detection channel 2 (0 = OK, 1 = error)
	4	Output status channel 3
	5	Line fault detection channel 3 (0 = OK, 1 = error)
	6	Output status channel 4
	7	Line fault detection channel 4 (0 = OK, 1 = error)

DP configuration code 30		
Byte	Bit	Description
Output byte 1	0	Output channel 1
	1	Channel 1 = 0 enabled, 1 = invalid
	2	Output channel 2
	3	Channel 2 = 0 enabled, 1 = invalid
	4	Output channel 3
	5	Channel 3 = 0 enabled, 1 = invalid
	6	Output channel 4
	7	Channel 4 = 0 enabled, 1 = invalid

6.28.4 Line Fault Detection

The I/O module has a line fault detection function that can detect lead breakages and short circuits. Line fault detection can be switched on and off in the device type manager.

The line fault detection function is based on the measurement of a trickle current so low that it does not activate a connected valve.

6.28.5 Watchdog

The I/O module has a watchdog function. If the communication between the I/O module and com unit stops, the I/O module enters the safe state after 0.5 s.

6.28.6 Editing Device Data

All I/O module parameters that can be configured via the PROFIBUS class 1 master are listed below. See chapter 4

If the PROFIBUS class 1 master is not yet ready for operation, e.g., during partial commissioning, the remote I/O station can be configured with the help of the DTM and an external FDT framework application such as PACTware™. See chapter 5

If you are operating a master that has drivers or libraries, you do not need to worry about the octet strings. You only need to enter the relevant parameters.

All parameters are valid for each channel.

DP configuration string: 0x30
parameter string: type, data_1, ..., data_4

Type, data_1 ... data_4 (channel 1 ... channel 4)

Bit	Parameters	Selection
Type		
0 ... 3	Valve driver type LB6*1* or FB621*	10 = type 0 [6*10] (24.5 V/370 Ω) 11 = type 1 [6*11] (24.5 V/320 Ω) 12 = type 2 [6*12] (17.0 V/185 Ω) 13 = type 3 [6*13] (23.0 V/290 Ω) 14 = type 4 [6*14] (23.0 V/355 Ω) 15 = type 5 [6*15] (16.2 V/78 Ω)
4 ... 7	-	-
Data_1 ... data_4 (channel 1 ... channel 4)		
0	Line fault detection	0 = off 1 = on
1	Inverter	0 = off 1 = on

200337 2016-03

Bit	Parameters	Selection
2 ... 3	Substitute value	0 = logical 0 1 = logical 1 2 = last valid value 3 = current value
4 ... 7	-	-

Line fault detection

Activate line fault detection to monitor the connection at the field end. In the event of a fault (e.g., lead breakage or short circuit), corresponding diagnostics are transmitted.

Inverter

Choose between positive or negative logic for the digital signal.

Substitute value

The I/O module may issue substitute values in the event of an error. See chapter 6.2

Preferred Parameter Values

Parameters	Values
Line fault detection	Off
Inverter	Off
Substitute value	Off

6.29 LB6*16, FB6216, LB6*17, FB6217 Digital Output

6.29.1 Description

Versions

- LB6016, LB6017, digital output, non-intrinsically safe, with bus-independent shutdown input
- LB6116, LB6117, digital output, intrinsically safe, with bus-independent shutdown input
- FB6216, FB6217, digital output, intrinsically safe, with bus-independent shutdown input

Features

- Occupies 1 slot on the backplane
- Number of channels: 2 (parallel operation possible)
- The electrical data of the versions is different.

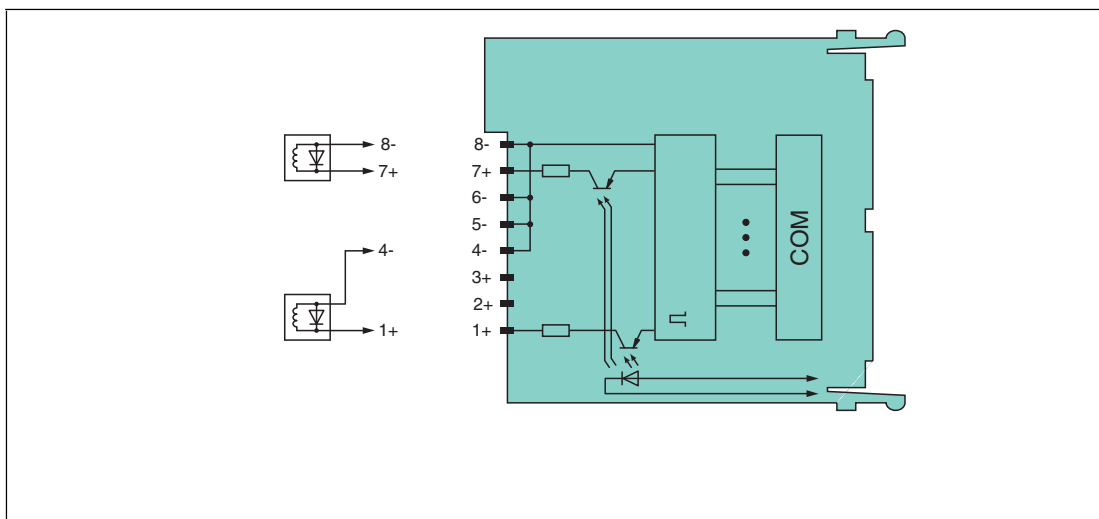

Figure 6.48 Block diagram: LB6*16, FB6216, LB6*17, FB6217 with shutdown input

Refer to the corresponding data sheet and operating instructions for further information.

6.29.2 Measuring Time and Cycle Time

The response time of the digital output is 10 ms. However, this time depends on the cycle time of the data traffic on the bus.

The signals are transmitted to the com unit every 6.5 ms irrespective of the measuring time.

6.29.3 Data Transfer

Data is transferred as specified in the PROFIBUS specification.

Successful PROFIBUS communication requires that the configuration, in particular the DP configuration string, in the master and the remote I/O station are identical. The configuration parameters are stored in the GSD/GSE file.

If the GSD/GSE file can be incorporated into the master, the DP configuration code for the relevant I/O module is copied automatically. If the GSD/GSE file cannot be incorporated, the configuration parameters must be entered in accordance with the table in this chapter. In addition to the GSD/GSE file, there are drivers available for further integration into various masters. The drivers provide the signals for the remote I/O station in processed format, meaning a manual integration of the I/O data in the data structures of the master is unnecessary.

Input and Output Data

The I/O module has input and output data.

The output data sets the control outputs and marks the data as valid or invalid. As soon as the **data invalid** error bit is set, the substitute values are used.

The input data allows the master to retrieve the current output status.

6.29.4 Line Fault Detection

The I/O module has a line fault detection function that can detect lead breakages and short circuits. Line fault detection can be switched on and off in the device type manager.

The line fault detection function is based on the measurement of a trickle current so low that it does not activate a connected valve.

6.29.5 Watchdog

The I/O module has a watchdog function. If the communication between the I/O module and com unit stops, the I/O module enters the safe state after 0.5 s.

6.29.6 Editing Device Data

All I/O module parameters that can be configured via the PROFIBUS class 1 master are listed below. See chapter 4

If the PROFIBUS class 1 master is not yet ready for operation, e.g., during partial commissioning, the remote I/O station can be configured with the help of the DTM and an external FDT framework application such as PACTware™. See chapter 5

If you are operating a master that has drivers or libraries, you do not need to worry about the octet strings. You only need to enter the relevant parameters.

All parameters are valid for each channel.

DP configuration string: 0x30

parameter string for LB6*16, FB6216: 0xA1, data_1, data_2

parameter string for LB6*17, FB6217: 0xA2, data_1, data_2

Data_1, Data_2 (Channel 1, Channel 2)

Bit	Parameter	Selection
Data_1, Data_2 (Channel 1, Channel 2)		
0	Line fault detection	0 = off 1 = on
1	Inverter	0 = off 1 = on
2 ... 3	Substitute value	0 = logical 0 1 = logical 1 2 = last valid value 3 = current value
4 ... 7	-	-

Line fault detection

Activate line fault detection to monitor the connection at the field end. In the event of a fault (e.g., lead breakage or short circuit), corresponding diagnostics are transmitted.

Inverter

Choose between positive or negative logic for the digital signal.

Substitute value

The I/O module may issue substitute values in the event of an error. See chapter 6.2



Preferred Parameter Values

Parameters	Values
Line fault detection	Off
Inverter	Off
Substitute value	Off

6.30 LB7*04, FB7*04 Universal Input/Output (HART)

6.30.1 Description

Versions

- LB7004, Universal Input/Output (HART), not intrinsically safe
- FB7304, Universal Input/Output (HART), increased safety terminals
- LB7104, Universal Input/Output (HART), intrinsically safe
- FB7204, Universal Input/Output (HART), intrinsically safe

Features

- Occupies 1 slot on the backplane
- Number of channels: 4
- Channels can be set as analog input (HART), analog output (HART), digital input or digital output.
 - Suitable sensors for analog inputs: pressure, differential pressure, filling level, flow rate and temperature converters, etc.
 - Suitable sensors for analog outputs: proportional valves, I/P converters, local indicators
 - Suitable field devices for digital inputs: mech. contacts and optocouplers
 - Suitable field devices for digital outputs: solenoid valves, acoustic sensors, and LEDs (line fault detection can be disabled)

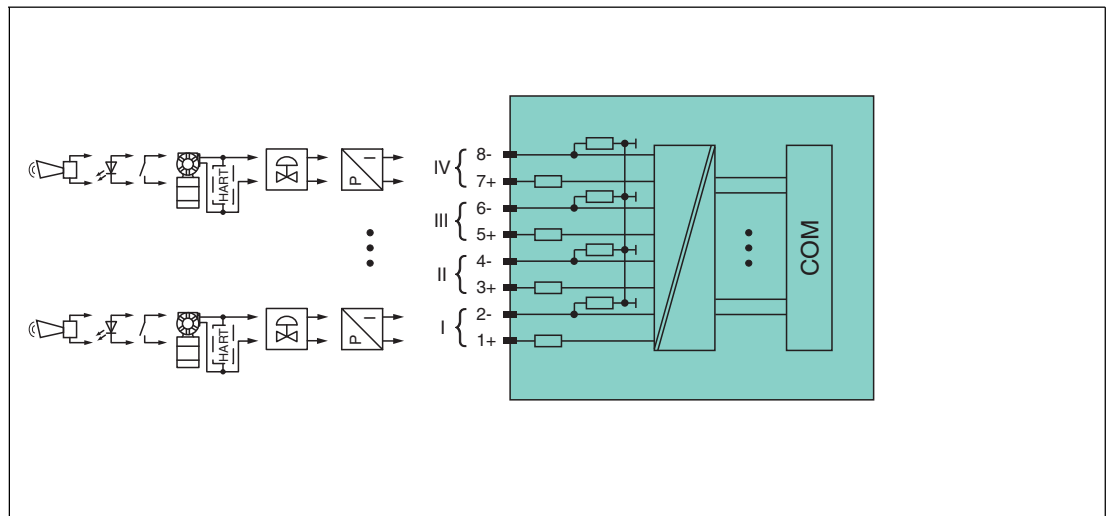

Figure 6.49 Block diagram LB7*04, FB7*04

The connection layout and other technical data can be found on the relevant data sheet.

6.30.2 Measuring Time and Cycle Time

The update rate for all 4 channels together is approx. 100 ms. The accuracy of the measured value depends on the cycle time of the data traffic on the bus. The signals are transmitted to the com unit every 6.5 ms irrespective of the measuring time.

6.30.3 Data Transfer

Data is transferred as specified in the PROFIBUS specification.

Successful PROFIBUS communication requires that the configuration, in particular the DP configuration string, in the master and the remote I/O station are identical. The configuration parameters are stored in the GSD/GSE file.

If the GSD/GSE file can be incorporated into the master, the DP configuration code for the relevant I/O module is copied automatically. If the GSD/GSE file cannot be incorporated, the configuration parameters must be entered in accordance with the table in this chapter. In addition to the GSD/GSE file, there are drivers available for further integration into various masters. The drivers provide the signals for the remote I/O station in processed format, meaning a manual integration of the I/O data in the data structures of the master is unnecessary.

A data container with 16-bit input data and 16-bit output data is available for the data transfer for each channel. The four data containers can be filled with analog or digital process values in accordance with the selected channel type (AI, AO, DI, DO).

Analog process values are transferred via unsigned integers within the range 0 ... 65535. The 4 bits of the lowest order are of little importance for the accuracy of the measured value and are therefore used for transferring status information. Status information is omitted if the scaling is outside the range of 10000 ... 50000.

		DP configuration code 73			
		Channel type AI	Channel type AO	Channel type DI	Channel type DO
Word	Bit	Description	Description	Description	Description
Input word 1 Channel 1	0	Live zero if current ≤ 3.6 mA (*)	Empty	Measured value channel 1	Mirrored process value channel 1
	1	Status (0 = OK, 1 = error)	Status (0 = OK, 1 = error)	Status (0 = OK, 1 = error)	Status (0 = OK, 1 = error)
	2 ... 3	Empty	Empty	Empty	Empty
	4 ... 15	Measured value channel 1 (12 bit)	Feedback measured value channel 1	Empty	Empty
Input words 2, 3, 4 Channels 2, 3, 4		Same structure as input word 1 for channel 1			
Output word 1 Channel 1	0	Empty	Empty	Empty	Process value channel 1
	1	Empty	Invalid identifier channel 1 (0 = OK, 1 = error)	Empty	Invalid identifier channel 1 (0 = OK, 1 = error)
	2 ... 3	Empty	Empty	Empty	Empty
	4 ... 15	Empty	Process value channel 1 (12 bit)	Empty	Empty
Output words 2, 3, 4 Channels 2, 3, 4		Same structure as output word 1 for channel 1			
(*) The live zero monitoring transmits one error bit (= 1) if the current falls below the minimum of 3.6 mA.					

6.30.4 Line Fault Detection

Analog Input

For analog inputs the line fault detection can detect line breakages or short circuits. Line fault detection can be switched on and off in the Device Type Manager.

You can preset the switching points at which a lead breakage or a short circuit is signaled, e.g., line breakage < 1 mA and short circuit > 21 mA.

The current circuit has Live Zero monitoring. If the current falls below the minimum of 3.6 mA, an error bit is set (= 1).

Analog output

For analog inputs the line fault detection can detect line breakages. Line fault detection can be switched on and off in the Device Type Manager.

Line fault detection works on the basis of measuring a minimum current of 1 mA. This current still flows even when the control system specifies 0 mA. The line fault detection function is therefore unsuitable for 0 mA ... 20 mA outputs. When currents < 0.1 mA are detected, a lead breakage is signaled.

Digital Input

For NAMUR proximity switches, the line fault detection can detect line breakages or short circuits. Line fault detection can be switched on and off in the Device Type Manager.

If you are using mechanical contacts, deactivate line fault detection or connect the mechanical contact at the installation location using an additional resistor circuit. Using the resistor circuit, the electronic circuit can distinguish between a closed switch and a short circuit. The resistor circuit is available as an accessory.



Figure 6.50 Resistor network for line fault detection

Digital Output

For digital outputs, the line fault detection can detect line breakages or short circuits. Line fault detection can be switched on and off in the Device Type Manager.

The line fault detection is based on the measurement of a trickle current so low that it does not activate a connected valve.

6.30.5 Watchdog

The I/O module has a watchdog function. If the communication between the I/O module and com unit stops, the I/O module enters the safe state after 0.5 s.

6.30.6 Editing Device Data

All I/O module parameters that can be configured via the PROFIBUS class 1 master are listed below. See chapter 4

If the PROFIBUS class 1 master is not yet ready for operation, e.g., during partial commissioning, the remote I/O station can be configured with the help of the DTM and an external FDT framework application such as PACTware™. See chapter 5

If you are operating a master that has drivers or libraries, you do not need to worry about the octet strings. You only need to enter the relevant parameters.

All parameters are valid for each channel.

Each channel can be operated as an analog input (AI), analog output (AO), digital input (DI) or a digital output (DO). A combination of analog and digital I/O is possible.

DP configuration string: 0x73

parameter string: 0x74, data_1, data_2, data_3

Data_1, data_2, data_3

Bit	Parameters	Selection
Data_1		
0 ... 1	Channel type channel 1	0 = analog input 1 = analog output 2 = digital output 3 = digital input
2 ... 3	Channel type channel 2	0 = analog input 1 = analog output 2 = digital output 3 = digital input
4 ... 5	Channel type channel 3	0 = analog input 1 = analog output 2 = digital output 3 = digital input
6 ... 7	Channel type channel 4	0 = analog input 1 = analog output 2 = digital output 3 = digital input
Data_2		
0	Line fault detection channel 1	0 = off 1 = on
1	Line fault detection channel 2	0 = off 1 = on
2	Line fault detection channel 3	0 = off 1 = on
3	Line fault detection channel 4	0 = off 1 = on
4	Operating mode channel 1	0 = 4 ... 20 mA (live zero) 1 = 0 ... 20 mA (dead zero)
5	Operating mode channel 2	0 = 4 ... 20 mA (live zero) 1 = 0 ... 20 mA (dead zero)
6	Operating mode channel 3	0 = 4 ... 20 mA (live zero) 1 = 0 ... 20 mA (dead zero)
7	Operating mode channel 4	0 = 4 ... 20 mA (live zero) 1 = 0 ... 20 mA (dead zero)
Data_3		
0 ... 1	Analog filter channel 1 ... 4	0 = off 1 = 100 %/s 2 = 10 %/s 3 = 1 %/s
2 ... 3	Substitute value channel 1 ... 4	0 = current value 1 = -2.5 % or off 2 = 106.25 % or on 3 = last valid value
4 ... 7	–	–

200337 2016-03

Channel type

The channels can be used as either analog input, analog output, digital output, or digital input. A combination of analog and digital inputs and outputs is possible.

Line fault detection

Activate line fault detection to monitor the connection at the field end. In the event of a fault (e.g., lead breakage or short circuit), corresponding diagnostics are transmitted.

Operating mode

The **Operating mode** parameter defines the operating range of the I/O module with 0 ... 20 mA (Dead Zero) or 4 ... 20 mA (Live Zero).

Analog filter

The analog filter for damping the signal can be activated if the input signals fluctuate. The value defines the rate of change of the input value in % per second. On the slowest setting of 1 %/s, it takes 90 seconds for a 90 % modification of the input signal to pass through the filter completely. The measurement range is used as the reference value (characteristic: ramp, linear).

Substitute value

The I/O module may issue substitute values in the event of an error. See chapter 6.2

Preferred Parameter Values

Parameters	Values
Channel type	Analog Input
Line fault detection	Off
Operating mode	4 mA ... 20 mA
Analog filter	Off
Substitute value	Current value

7 Com Unit Diagnostics Functions

The measured value display of the Com Unit provides diagnostic information relating to the complete remote I/O station. This chapter describes the structure of the measured value display and shows which diagnostics information is available.

7.1 Data Transfer



Note!

The following diagnostics can be accessed in the PROFIBUS class 2 master. If not, the diagnostics can be obtained using a PROFIBUS network analysis tool.



Data Transfer in Three Steps

The bus must have successfully passed the electrical test. See chapter 4.9

1. Make sure that the slave address is identical for both the master and slave.

↳ The slave can be activated via the bus.

`DP Diagnostic Station_Non_Existent == 0`

2. Make sure that the PROFIBUS ID in the slave is the same as the ID in the GSD file.

↳ The slave accepts the parameters of the master.

`DP Diagnostics Prm_Fault == 0`

3. Check that the configuration of the I/O modules in the master matches the configuration of the I/O modules in the remote I/O station.

Note that the data volumes in the I/O modules LB1*03, FB1*03, and LB3*02, FB3*02 depend on the **measuring methods** used.

Configure dual width I/O modules that occupy two slots in the same way as single width I/O modules, followed by an empty slot. Be aware that the last slot in the remote I/O station may not be an empty slot. If the last I/O module is a dual width I/O module, configure this I/O module in the same way as a single width I/O module and omit the following empty slot.

The start number for the module slot numbering is changed by the command area (Cmd), status area (Status), and module status area (Mod.-status).

↳ The slave accepts the configuration of the master.

`DP Diagnostics Cfg_Fault == 0`

7.2 Opening the measured value display of the Com Unit



Opening the "Show Measured Value" window

1. Right-click on the entry for the required component in the project structure.

2. Choose **Connect**.

↳ The connection is established. The entries appear in bold in the project structure once the connection is established. The connection status is also indicated by an icon.

3. Right-click on the entry for the connected device in the project structure.

4. In the context menu, select **Measured Value > Show Measured Value**. If the command is not available, there is no connection to the device.

↳ The **Show Measured Value** window opens.

7.3 Layout of the Measured Values Display

The com unit measured values display is divided into four areas.

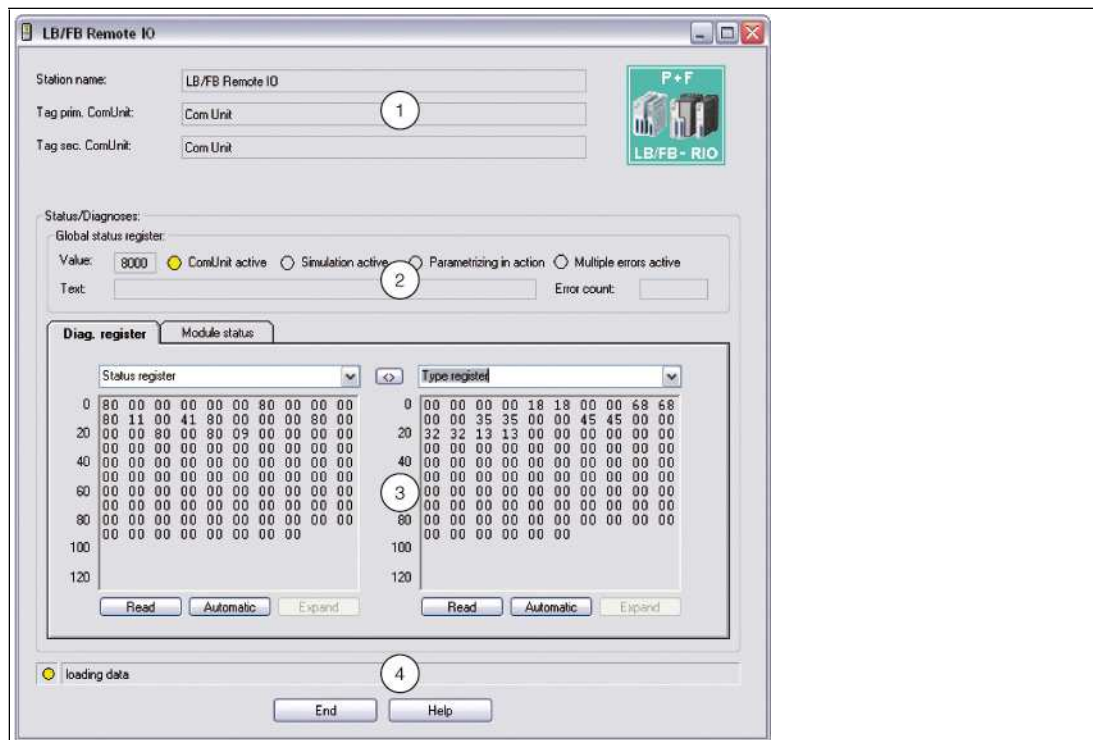

Figure 7.1 Display Measured Value window

Field	Explanation	
1	Station name Prim. com unit tag Sec. com unit tag	The fields contain the names of the station and the primary com unit. On redundant systems, the name of the secondary com unit (redundant com unit) is also displayed.
2	Global status register	The global status register contains information about the status of the com unit, the I/O modules, and the power supplies of a station.
3	Tabs	This area contains several tabs. The first Diagnostics register tab displays the raw data for the different diagnostic registers. Depending on the com unit type, additional diagnostic information is displayed via additional tabs. The Module Status tab is available from DTM version 7.3.
4	Status bar	The status bar provides information about the communication status. The display lights up yellow in the case of read access. The display lights up red if there is a communication error. The communication status is displayed as a text message in the text box. Data loading: The read request was successful. The measured value display waits for the requested data. Wait...: The read request was unsuccessful because the communication channel is currently in use. Communication error: The requested data could not be transferred.

7.4 Global Status Register

The global status register comprises 16 bits (= 1 data word) and contains information about the status of the com unit, I/O modules, and power supplies of a Remote I/O station. The global status register is displayed in the **Show Measured Value** window as a raw data value in the **Value** field and as a text message in the **Text** field.

Using the com unit parameters, you can set whether the global status register is transferred in synchronous data traffic.

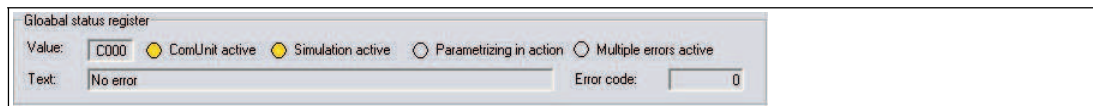

Figure 7.2 Com Unit measured value display, **Global status register** area

7.4.1 Structure of the Global Status Register

The global status register comprises 2 bytes. The meaning of the individual bits is shown in the table below.

Structure of the Global Status Register

Byte	Bit/state	Meaning	
2	15	= 0	Com unit is passive
		= 1	Com unit is active
	14	= 0	Operating mode: no simulation
		= 1	Operating mode: a minimum of one I/O module is simulated.
	13	= 0	No fault
		= 1	Fault
	12	= 0	General fault
		= 1	Module fault
	11		The error code consists of bits 11 to 8, e.g., 0 1 1 1, produces an error code of 7 (hexadecimal) = power supply fault. The meaning of all error codes is shown in the table below.
	10		
9			
8			
1	7	= 0	1 fault
		= 1	Multiple faults
	6	= 0	No parameterization/processing
		= 1	Parameterization/processing in progress
	5		Bits 5 ... 0: ■ If a single error occurs (bit 7 = 0), the faulty slot can be determined with reference to these bits, e.g., 0 0 0 1 0 0 indicates slot 4 (hexadecimal). ■ If multiple errors occur (bit 7 = 1), the number of errors can be determined. ■ If only power supply faults occur (bit 11... 8 = 7, bit 7 = 0), one bit is assigned to each power supply (power supply 1 = bit 0, ..., power supply 6 = bit 5), whereby the status 1 represents a fault.
	4		
	3		
	2		
1			
0			

200337 2016-03

Error code of the global status register

Error code (hex)	Clear text message
0	No error
1	Memory error PIC (RAM)
2	Memory error PIC (register)
3	Memory error PIC (flash)
4	PIC internal error
5	Command error PIC
6	Module fault
7	Power supply fault
8	Memory error CPU32 (RAM)
9	Memory error CPU32 (flash)
A	CPU32 internal error (watchdog)
B	Redundancy error, arithmetic
C	Redundancy error, partner not present (no redundancy Com Unit)
D	Redundancy error, link
E	Redundancy error, parameter inconsistent
F	Reserved

7.4.2 Example of Global Status Register

There is a power supply fault in the following example. The **Value** field contains the raw data value A784.

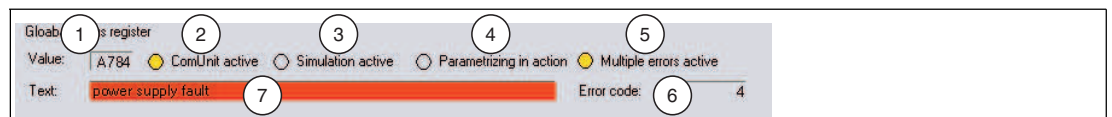

Figure 7.3 Com unit measured value display, **Global status register** area

The value is produced from the 16 bits in the status register. The table below outlines how the raw data value A784 is compiled and on which status displays the value appears.

Example of Global Status Register (Raw Data Value "A784")

A784	Bit/state	Meaning	Image reference
A	15 = 1	Com unit is active Status indicated by Com unit active yellow = active gray = passive	2
	14 = 0	Simulation is not active Status indicated by Simulation active yellow = min. 1 channel simulated gray = no simulation	3
	13 = 1	Error has occurred Status indicated by Text box red background = error gray background = no error	7
	12 = 0	General error no status indicator	
7	11 = 0	Bits 11 ... 8 with states 0 1 1 1 produce the error code 7. The error with the highest priority is a power supply fault.	7
	10 = 1		
	9 = 1		
	8 = 1		
8	7 = 1	Multiple errors have occurred Status indicated by Multiple errors active yellow = multiple errors gray = no errors or single error	5
	6 = 0	No parameterization/processing Status indicated by Parameterization in progress yellow = parameterization in progress gray = no parameterization	4
	5 = 0	There are 4 active errors (multiple errors) Bits 5 ... 0 with the states 0 0 0 1 0 0 produce the number 4.	6
	4 = 0		
4	3 = 0		
	2 = 1		
	1 = 0		
	0 = 0		

7.5 "Diagnostics Register" Tab

Different diagnostic areas in the com unit can be read out and compared with one another using the **Diagnostics Register** tab. Press the <> button in the middle of both areas to highlight differences between the diagnostic areas in the left- and right-hand text boxes in color until the data is updated again.

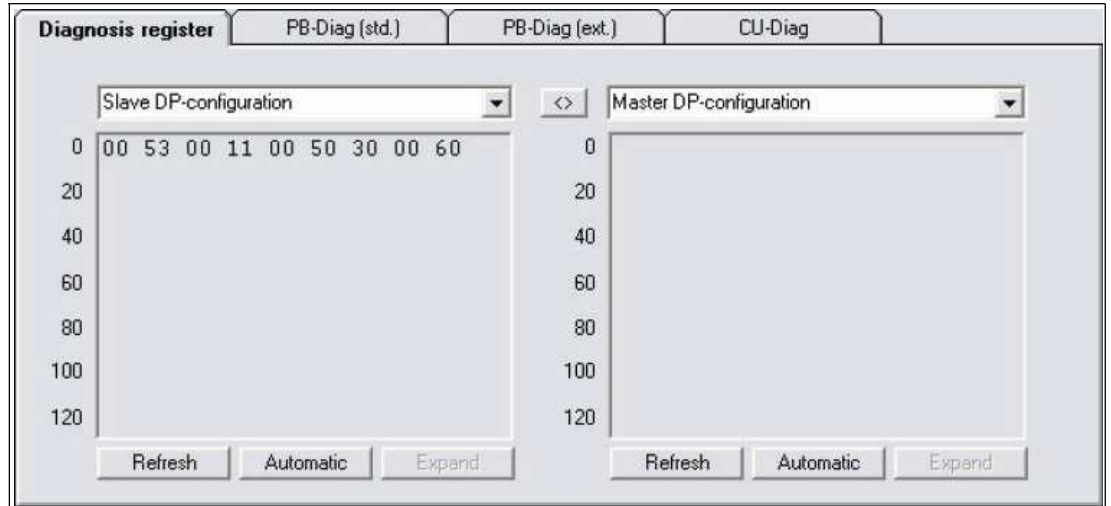

Figure 7.4 **Diagnostics Register** tab

7.5.1 DP Configuration

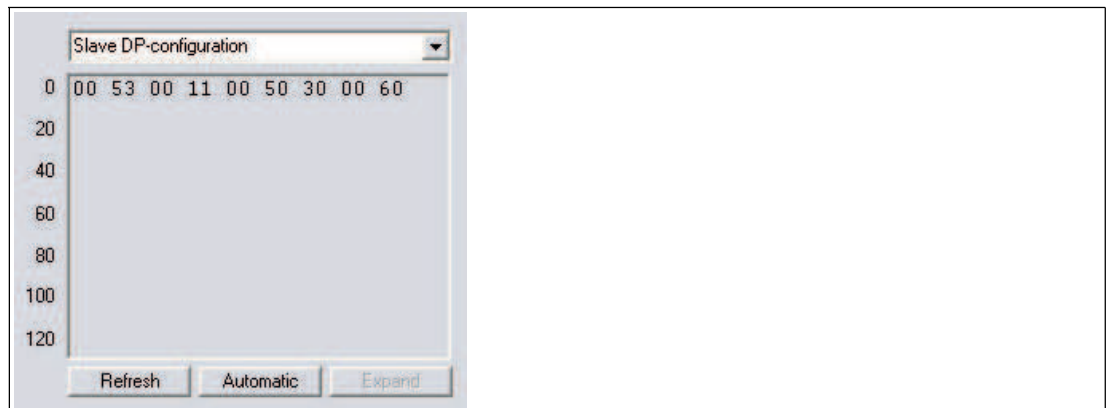

Figure 7.5 DP configuration

If you select the **Slave DP Configuration** or **Master DP Configuration** entry from the drop-down list, the DP configuration string for the slave or the master appears in the text box. You can directly compare the DP configuration string of the slave and the master in the left and right hand area. When configured correctly, the DP configuration strings of the slave and master should be identical. → see Figure 7.4 on page 197

The DP configuration string comprises the hexadecimal DP configuration codes of the individual components of the Remote I/O station. The DP configuration string is compiled automatically when adding and configuring the Remote I/O modules. As soon as the configuration is activated, the corresponding configuration string appears in the **Slave DP Configuration** diagnostics register.

Structure of the DP Configuration Code

Bit	Meaning
7	Data consistency: 0 = byte/word, 1 = total data
6	Data format: 0 = byte, 1 = word
5	Bits 5 ... 4: Data type: 00 = special type, 01 = input, 10 = output, 11 = input/output
4	
3	Bits 3 ... 0 Data length: e.g., 0000 = 1 byte/word, 0011 = 4 bytes/word, 1111 = 16 bytes/word
2	
1	
0	

7.5.2 DP Diagnostics

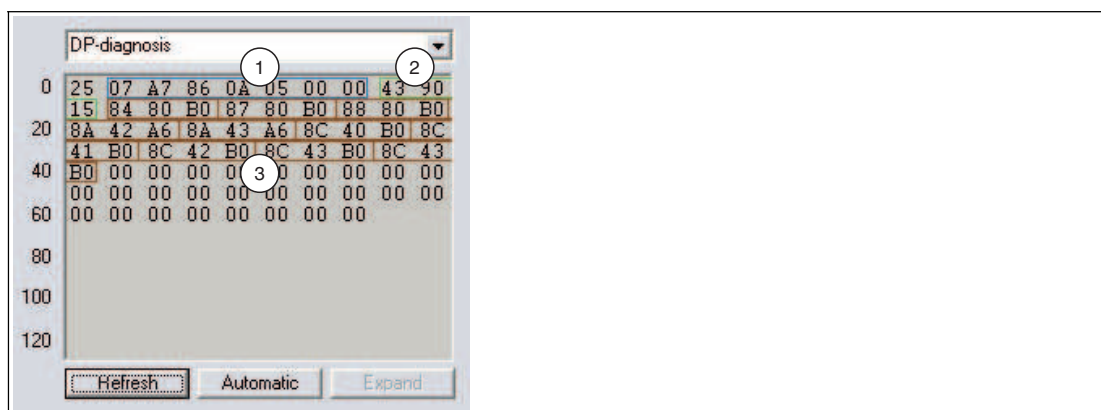

Figure 7.6 DP diagnostics

If you select the **DP Diagnostics** entry from the drop-down list, the extended PROFIBUS diagnostic bytes are displayed in the box. This data is part of the diagnostic telegram, in addition to the PROFIBUS standard diagnostics. The Remote I/O station then always transmits a diagnostic telegram as soon as the master issues a diagnostics request (DP Diag Response).

The data encoding is determined by the PROFIBUS specification and is briefly described below. The diagnostic data is evaluated on the **DP Diag (Ext.)** tab, which also forms part of the com unit measured values display.

The extended PROFIBUS diagnostics is divided into 3 areas.

1: Device-specific diagnostic bytes

Device-specific diagnostic bytes in the first area contain information on the status of the Remote I/O station and depend largely on the parameterization of the com unit. The example involves bytes 1 to 7.

- Byte 1: header byte with identifier for device-specific diagnostics (bit 7 = 0 and bit 6 = 0) and 6 bits (bit 5 ... 0) specifying the length of the device-specific diagnostics, including header byte (in the example: 07 = 7 bytes).
- Bytes 2 + 3: 2 byte global status register for the active com unit (in the example: A7 86).
- Bytes 4 + 5: the first two standard diagnostic bytes of the redundant com unit (in the example: 0A 05) → see Figure 7.11 on page 210
- Bytes 6 + 7: 2-byte global status register for the redundant com unit. The passive com unit does not transfer error messages and so most transferred bytes are set to 0. See chapter 7.4

The last four bytes (7 ... 4) are only relevant for redundant systems with 2 com units and are filled with default values in single mode.

If you have enabled **Additional Module Diagnostics** in the com unit parameters, 2 more bits are transferred per I/O slot in contrast to the example shown above.

The data volume of the device-specific diagnostics increases by 12 bytes (48 slots x 2 bits), regardless of the I/O modules that are actually configured. The 2 bits for each slot represent the following states: 00 = no error, 01 = module error, 10 = incorrect module type, 11 = no module available. The transfer sequence is shown in the table below.

Additional Module Diagnostics

Byte	Bit	Description
Byte $n+1$ (*)	7	Status slot 4
	6	
	5	Status slot 3
	4	
	3	Status slot 2
	2	
	1	Status slot 1
	0	
...
Byte $n+12$ (*) Status slot 48

(*) byte n = last byte before the additional module diagnostics

2: Module-Specific Diagnostic Bytes

The second extended diagnostics area contains module-specific diagnostic bytes (bytes 8 ... 10, in the example: 43 90 15). Here, one bit is assigned to each com unit and I/O module of the remote I/O station or to each configuration code in the DP configuration string. If one bit is preset (= 1), diagnostics are available for the module assigned to this bit.

The number of bytes in the module-specific diagnostics depends on the configuration of the Remote I/O station. The more I/O modules that are assigned to slots, the higher the number of bytes. The evaluation structure can also be applied for longer module diagnostics, regardless of the number of diagnostic bytes. Each additional bit represents the next I/O module.

The evaluation structure of the module-specific diagnostic bytes is shown in the following table with reference to the example in the illustration.

Module-Specific Diagnostic Bytes

Byte	Bit/state		Meaning, general	Example of meaning
Byte n Example: 43 (*)	7	= 0	Diagnostics type: 0 0 = device-spec. diagnostics; 0 1 = module-spec. diagnostics; 1 0 = channel-spec. diagnostics; 1 1 = reserved	Module-specific diagnostics (0 1) 3 bytes in length (0 0 0 0 1 1)
	6	= 1		
	5	= 0	Number of bytes in the diagnostics, including header byte	
	4	= 0		
	3	= 0		
	2	= 0		
	1	= 1		
	0	= 1		

Byte	Bit/state		Meaning, general	Example of meaning
Byte $n+1$ Example: 90	7	= 1	Module 8 (diagnostic or error message)	Modules 5 and 8 have error or diagnostic messages
	6	= 0	Module 7 (no error)	
	5	= 0	Module 6 (no error)	
	4	= 1	Module 5 (diagnostic or error message)	
	3	= 0	Module 4 (no error)	
	2	= 0	Module 3 (no error)	
	1	= 0	Module 2 (no error)	
	0	= 0	Module 1 (no error)	
Byte $n+2$ Example: 15			Modules 9 to 16	Modules 9, 11, and 13 have error or diagnostic messages
...	
Byte $n+x$			Modules y to $y+7$	Not included in the example
(*) byte n = header byte of module-specific diagnostics				

3: Channel-Specific Diagnostic Bytes

The module-specific diagnostics is followed by the channel-specific diagnostics. The channel-specific diagnostics contains information on the channel properties and the error/diagnostics type (in the example: bytes 11 to 40). The channel-specific diagnostics is divided into blocks of 3 bytes, where one block represents one channel.

The diagnostics are evaluated according to the structure displayed in the table below using the first 3 bytes from the example (84 80 B0). Some parts of the error types, diagnostics types and associated codes are predefined in the PROFIBUS specification. Other parts can be defined independently using the GSD/GSE file from the device manufacturer.

The memory for diagnostic information is limited. The maximum number of channel-specific diagnostics is also limited because each additional channel diagnostics requires 3 extra bytes. If more diagnostics are present than can be transferred, the PROFIBUS standard diagnostic bit **Diagnostic Data Overflow** is displayed.

Channel-Specific Diagnostic Bytes

Byte	Bit/state		Meaning, general	Example of meaning
Byte n Example: 84 (*)	7	= 1	Diagnostics type: 0 0 = device-spec. diagnostics; 0 1 = module-spec. diagnostics; 1 0 = channel-spec. diagnostics; 1 1 = reserved	Channel-specific diagnostics (1 0) for module 5 or configuration code 4 (0 0 0 1 0 0) (if diagnostics offset = 0 and the configuration code starts with 0)
	6	= 0		
	5	= 0		
	4	= 0	Assignment to the module or configuration code (offset-dependent)	
	3	= 0		
	2	= 1		
	1	= 0		
	0	= 0		

Byte	Bit/state		Meaning, general	Example of meaning
Byte $n+1$ Example: 80	7	= 1	Input/output: 0 0 = reserved; 0 1 = input; 1 0 = output; 1 1 = input and output	Diagnostics are based on an output value (1 0) and apply to channel 1 (0 0 0 0 0)
	6	= 0		
	5	= 0	Assignment of the diagnostics to a channel	
	4	= 0		
	3	= 0		
	2	= 0		
	1	= 0		
	0	= 0		
Byte $n+2$ Example: B0	7	= 1	Data structure: 0 0 0 = reserved; 0 0 1 = 1 bit; 0 1 0 = 2 bits; 0 1 1 = 4 bits; 1 0 0 = 1 byte; 1 0 1 = 1 word; 1 1 0 = 2 words; 1 1 1 = reserved	Data structure = 1 word (1 0 1); diagnostic message = lead breakage or short circuit (1 0 0 0 0 = 16)
	6	= 0		
	5	= 1		
	4	= 1	Diagnostic message (see table below)	
	3	= 0		
	2	= 0		
	1	= 0		
	0	= 0		
(*) byte n = header byte of channel-specific diagnostics				

Channel-specific diagnostic messages

Identifier	Diagnostic message
PROFIBUS specification	
1	Short circuit
2	Undervoltage
3	Overvoltage
4	Overload
5	Excess temperature
6	Lead breakage
7	Upper limit exceeded
8	Lower limit undershot
9	Fault
10 ... 15	Reserved
Manufacturer specification (defined in GSD file)	
16	Short circuit or lead breakage
17 ... 31	Reserved

7.5.3 DP Parameters

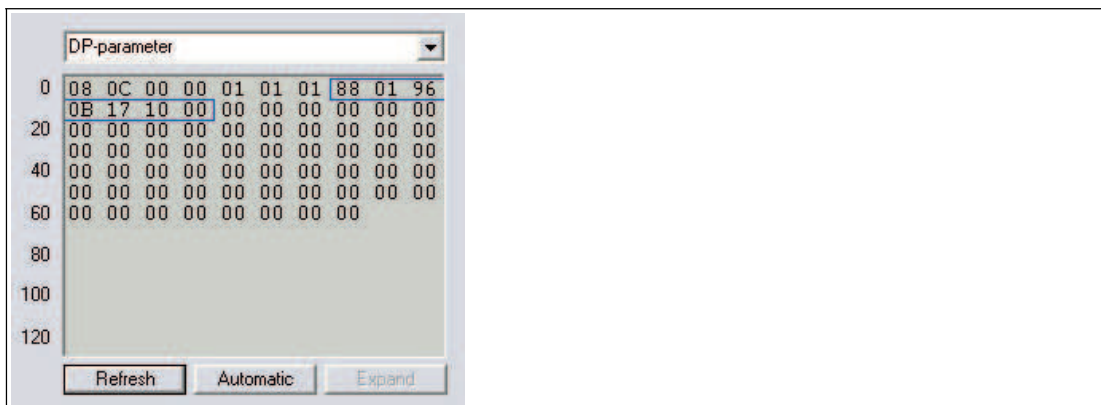

Figure 7.7 DP parameters

If you select the **DP Parameters** entry from the drop-down list and then click on the **Read** button, the data of the parameterization telegram (`SetParam`) is displayed in the text box (in the example: bytes 7 ... 13). The other listed bytes are not relevant for diagnostics purposes and are therefore not described here in more detail.

If you select the **DP Parameters (Partner)** entry from the drop-down list, you access the parameterization telegram for the redundant com unit (redundant systems only). The structure of the two DP parameter registers **DP parameters** and **DP parameters (partner)** is identical and is therefore only described once in the following section.

The first byte of the parameterization telegram (in the example: 88) represents PROFIBUS-specific modes and functions that can be activated and deactivated via the parameterization telegram. The meaning of the individual bits is shown in the table below.

DP parameters byte 1

Byte	Bit/state	Meaning, general	Example of meaning	
Byte 1 Example: e: 88	7	= 1	Lock (0 = off; 1 = on)	Lock function and watchdog activated
	6	= 0	Unlock (0 = off; 1 = on)	
	5	= 0	SYNC mode (0 = off; 1 = on)	
	4	= 0	FREEZE mode (0 = off; 1 = on)	
	3	= 1	Watchdog (0 = off; 1 = on)	
	2	= 0	Reserved	
	1	= 0	Reserved	
	0	= 0	Reserved	

- Watchdog:** When the watchdog function is activated, the com unit monitors the communication with the master. If the master does not respond to the com unit correctly within the watchdog time, the com unit interprets this as an error and reacts accordingly. The watchdog time is usually calculated by the master and must always be longer than the maximum time required for a complete data cycle. The watchdog time is transferred in bytes 2 and 3 of the parameterization telegram (in the example: 01 96) and can be calculated as follows:

$$\text{watchdog time} = (\text{decimal value byte 2}) \times (\text{decimal value byte 3}) \times 10 \text{ ms}$$

$$= 1 (01_{\text{hex}}) \times 150 (96_{\text{hex}}) \times 10 \text{ ms} = 1500 \text{ ms}$$
- FREEZE mode:** The input data of different slaves is always retrieved in succession. The point in time when signals are retrieved in normal mode therefore varies from slave to slave. FREEZE mode is used to freeze the input data of different slaves at a defined point in time and then the data is transferred in succession.

- **SYNC mode:** Like FREEZE mode, SYNC mode is used for synchronizing data, but only affects the outputs. This function allows you to transmit output data to different slaves in quick succession and then output this data simultaneously using the Sync command.
- **Lock/unlock:** The lock/unlock function enables the master to grant or rescind access rights to a slave. If the lock bit is set and the unlock bit is not set, the slave is reserved for a certain master (identified by the master address). If the unlock bit is set, the slave is not reserved for a certain master (the status of the lock bit is irrelevant in this case). If both the lock bit and the unlock bit are not set, the slave is still not reserved for a specific master and can be locked by a master using an appropriate parameterization telegram.

Bytes 2 and 3 of the parameterization telegram contain the watchdog time for the watchdog function.

Byte 4 contains the minimum time that the slave must wait before a response telegram may be transmitted (min. T_{SDR} in bit times; in the example: 11 (0B_{hex}) bit times).

Bytes 5 and 6 contain the high and low bytes for the PROFIBUS ID number (in the example: 17 10). The ID number that the master transmits to the slave in the parameterization telegram must correspond to the PROFIBUS ID number of the slave. If the ID numbers do not correspond, the parameterization telegram is not accepted and data exchange with the slave is not possible.

Byte 7 is used to assign the slave to a specific component group (in the example: 00_{hex} = group 0). Grouping in this way enables multicast communication (telegram is valid for a group of components). By default, group 0 is assigned to the slave (00_{hex}).

7.5.4 Redundancy Status

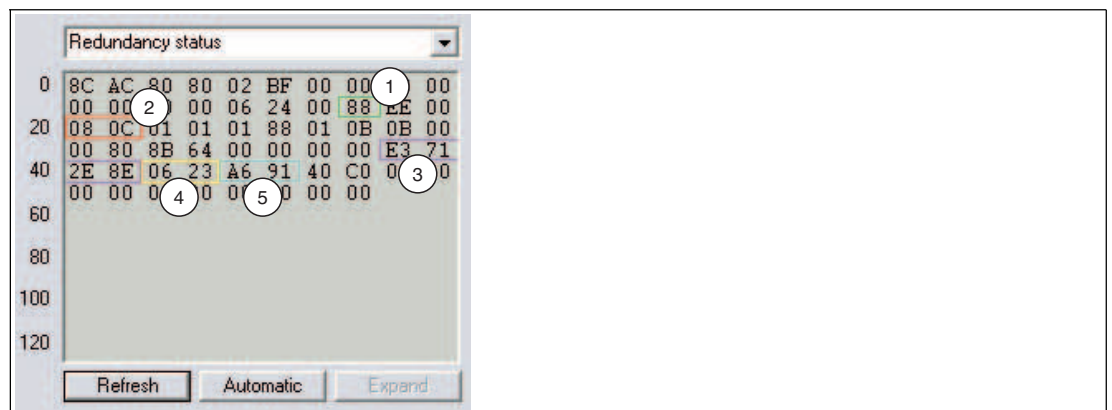

Figure 7.8 Redundancy status

The structure of the two redundancy status registers **Redundancy status** and **Redundancy status (partner)** is identical. If you select the entry **Redundancy status (partner)** from the drop-down list (only on redundant systems), you access the data record for the redundant com unit via the active com unit. Data is exchanged between the com unit and the redundancy com unit automatically.

Each redundancy status register contains a large amount of information. The most important information is highlighted in the illustration.

1: Communication Status

This octet contains information relating to PROFIBUS communication. The table below shows how this octet is interpreted. The example (88) shows that the slave has found a valid baud rate and has the status `DataExchange`.

Communication Status

Octet	Bit/state	General meaning	Example of meaning
Octet n Example: 88	7 = 1	DataExchange (0 = inactive, 1 = active)	Slave has the status DataExchange, baud rate was found
	6 = 0	Reserved	
	5 = 0		
	4 = 0		
	3 = 1	Baud rate (0 = not found, 1 = found)	
	2 = 0	Reserved	
	1 = 0		
	0 = 0		

2: PROFIBUS Standard Diagnostic Octets

PROFIBUS standard diagnostic octets 1 and 2 are stored at the position indicated (in the example: 08 0C). The way in which this octet is interpreted is defined by the PROFIBUS specification.

3: Checksum Calculation Result

This area contains the result of the checksum calculation for the parameter set of the com unit. With the exception of EasyCom connections, the data records must be identical in both com units in redundant systems. You can compare data records with one another using the <> button.

The revision counter value for the parameter set is also included in the checksum calculation. The result is that the checksum changes when the revision version increases and provides confirmation of the transmission of new parameters.

4: Firmware Version

This area contains the com unit firmware version.

5: Global Status Register

This area contains the global status register.

7.5.5

Status Register

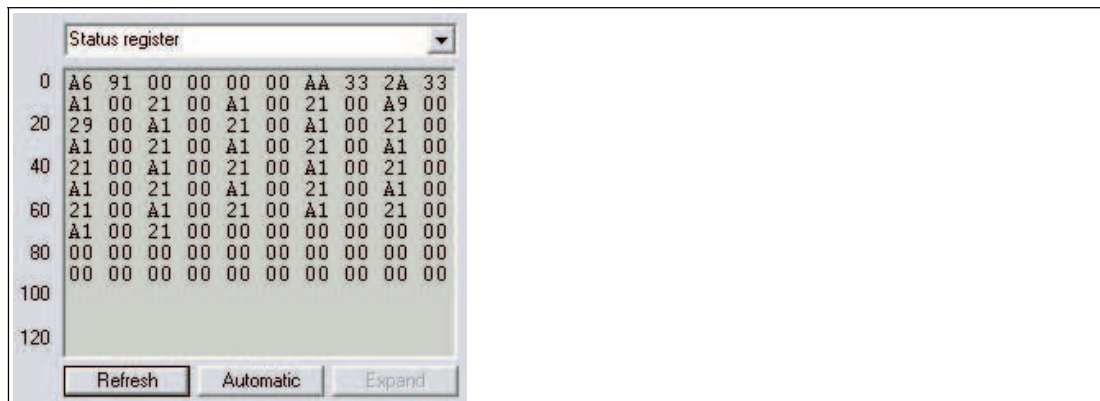

Figure 7.9 Status register

If you select the **Status register** entry from the drop-down list, the status bytes for the com unit and the I/O modules are displayed.

There are 2 status bytes available for each I/O module slot and for the bus connection (com unit or com unit + redundancy com unit). The first two bytes are allocated to the bus coupling and contain the global status register already described. This is followed by two bytes for each I/O module slot, beginning with slot 1. The meaning of the bytes is displayed in the following tables.

The first of the two status bytes contains module diagnostic information and has the same structure for each slot. The second status byte depends on the module type and contains channel diagnostic information. Since some dual-width I/O modules require two slots, these I/O modules are represented by 4 bytes (2 bytes per slot). In theory, bytes 1 and 3 have the same structure, in which only the first required module slot is assigned the **active** status. Bytes 2 and 4 contain the channel diagnostics information.

Module Status Register

Byte	Bit/state		General meaning	Example of meaning
Byte 1 Example: AA	7	= 1	Module active (0 = inactive, 1 = active)	The I/O module is active (bit 7 = 1) and faulty (bit 5 = 1). There is an internal module error (bit 3 ... 0 = 1 0 1 0 = error code 10 _{Hex})
	6	= 0	Simulation active (min. 1 channel) (0 = inactive; 1 = active)	
	5	= 1	Error (0 = no error; 1 = error)	
	4	= 0	Reserved	
	3	= 1	Error code (see table below)	
	2	= 0		
	1	= 1		
	0	= 0		
Byte 2			Channel diagnostics information	

Error codes bit 0 ... 3	Meaning
0	No fault
1	Timeout (module is not inserted in the slot)
2 ... 6	Internal bus error (communication problems between com unit and I/O module(s))
7 ... 8	Reserved
9	Incorrect module type (inserted and configured module types do not match)
10	Internal module error (e.g., lead breakage or short circuit)
11 ... 15	Reserved



Note!

The following I/O modules have **no** channel diagnostics information. In these I/O modules, byte 2 = 0.

- LB1007
- LB1*09, FB1*09
- LB1014
- LB1015
- LB3*06
- LB4106
- LB7*04, FB7*04

Channel diagnostics information

LB1*01, FB1*01, LB1*02, FB1*02, LB1*08, FB1*08, LB2002, LB21*, FB22*, LB6005, FB6305, LB6006, FB6306, LB6*08, FB6*08, LB6*1*, FB621*

Byte 2	Meaning	Byte 4 ^(*1)	Meaning
Bit 0	Digital data channel 1 (0/1)	Bit 0	Digital data channel 5 (0/1) ^(*2)
Bit 1	Status channel 1 (0 = valid, 1 = invalid)	Bit 1	Status channel 5 (0 = valid, 1 = invalid) ^(*2)
Bit 2	Digital data channel 2 (0/1)	Bit 2	Digital data channel 6 (0/1) ^(*2)
Bit 3	Status channel 2 (0 = valid, 1 = invalid)	Bit 3	Status channel 6 (0 = valid, 1 = invalid) ^(*2)
Bit 4	Digital data channel 3 (0/1) ^(*2)	Bit 4	Digital data channel 7 (0/1) ^(*2)
Bit 5	Status channel 3 (0 = valid, 1 = invalid) ^(*2)	Bit 5	Status channel 7 (0 = valid, 1 = invalid) ^(*2)
Bit 6	Digital data channel 4 (0/1) ^(*2)	Bit 6	Digital data channel 8 (0/1) ^(*2)
Bit 7	Status channel 4 (0 = valid, 1 = invalid) ^(*2)	Bit 7	Status channel 8 (0 = valid, 1 = invalid) ^(*2)
<p>(*1) Byte 4 only affects dual-width I/O modules that occupy 2 slots. (*2) This bit may only be reserved depending on the channel number of the I/O module.</p>			

LB6101, FB6301

Byte 2	Meaning
Bit 0	Digital data channel 1 (0/1)
Bit 1	Digital data channel 2 (0/1)
Bit 2 ... 7	Reserved

LB1*03, FB1*03

Byte 2	Meaning
Bit 0	Counter status
Bit 1	Status (0 = valid, 1 = invalid)
Bit 2	Reserved
Bit 3	Direction detection
Bit 4 ... 7	Reserved

LB3101, FB3201, LB3*02, FB3*02, LB3103, FB3203, LB3104, FB3204, LB3*05, FB3*05

Byte 2	Meaning	Byte 4 ^(*1)	Meaning
Bit 0	Live zero/breakage limit undershot channel 1	Bit 0	Live zero/breakage limit undershot channel 3 ^(*2)
Bit 1	Status channel 1 (0 = valid, 1 = invalid)	Bit 1	Status channel 3 (0 = valid, 1 = invalid) ^(*2)
Bit 2 ... 3	Reserved	Bit 2 ... 3	Reserved
Bit 4	Live zero/breakage limit undershot channel 2 ^(*2)	Bit 4	Live zero/breakage limit undershot channel 4 ^(*2)
Bit 5	Status channel 2 (0 = valid, 1 = invalid) ^(*2)	Bit 5	Status channel 4 (0 = valid, 1 = invalid) ^(*2)

200337 2016-03

Byte 2	Meaning	Byte 4 ^(*1)	Meaning
Bit 6 ... 7	Reserved	Bit 6 ... 7	Reserved
(*1) Byte 4 only affects dual-width I/O modules that occupy 2 slots. (*2) This bit may only be reserved depending on the channel number of the I/O module.			

LB4101, FB4*01, LB4*02, FB4*02, LB4104, FB4204, LB4*05, FB4*05

Byte 2	Meaning	Byte 4 ^(*1)	Meaning
Bit 0	Reserved	Bit 0	Reserved
Bit 1	Status channel 1 (0 = valid, 1 = invalid)	Bit 1	Status channel 3 (0 = valid, 1 = invalid) ^(*2)
Bit 2 ... 3	Reserved	Bit 2 ... 3	Reserved
Bit 4	Reserved	Bit 4	Reserved
Bit 5	Status channel 2 (0 = valid, 1 = invalid) ^(*2)	Bit 5	Status channel 4 (0 = valid, 1 = invalid) ^(*2)
Bit 6 ... 7	Reserved	Bit 6 ... 7	Reserved
(*1) Byte 4 only affects dual-width I/O modules that occupy 2 slots. (*2) This bit may only be reserved depending on the channel number of the I/O module.			

LB5*01, FB5201, LB5*02, FB5202, LB5*04, FB5204, LB5*05, FB5205, LB5*06, FB5206

Byte 2	Meaning	Byte 4 ^(*1)	Meaning
Bit 0	Reserved	Bit 0	Reserved
Bit 1	Status channel 1 (0 = valid, 1 = invalid)	Bit 1	Status channel 3 (0 = valid, 1 = invalid) ^(*2)
Bit 2 ... 3	Reserved	Bit 2 ... 3	Reserved
Bit 4	Reserved	Bit 4	Reserved
Bit 5	Status channel 2 (0 = valid, 1 = invalid) ^(*2)	Bit 5	Status channel 4 (0 = valid, 1 = invalid) ^(*2)
Bit 6 ... 7	Reserved	Bit 6 ... 7	Reserved
(*1) Byte 4 only affects dual-width I/O modules that occupy 2 slots. (*2) This bit may only be reserved depending on the channel number of the I/O module.			

7.5.6 Type Register

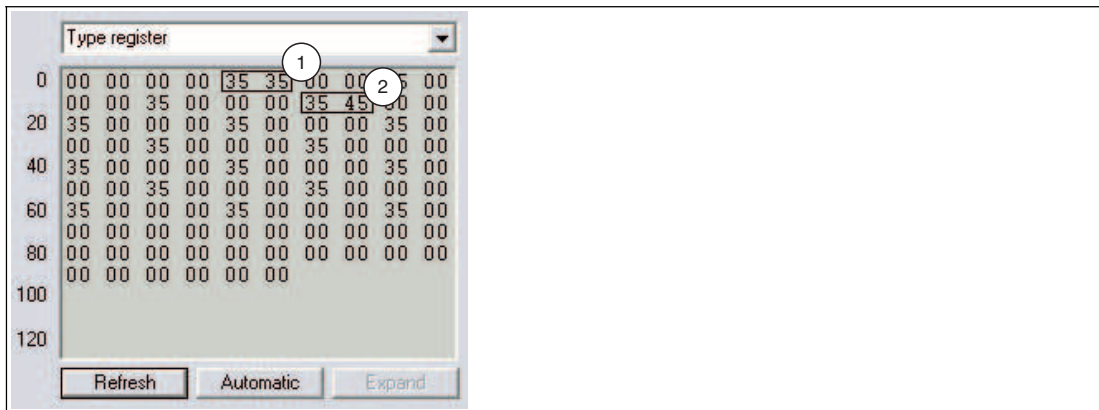

Figure 7.10 Type register

- 1 Slot 3
- 2 Slot 9

When you select the **Type register** entry from the drop-down list, an overview of the remote I/O station structure is displayed.

In the type register, two bytes are assigned to each slot. The first byte contains the identifier of the I/O module that is configured in the com unit. The second byte contains the identifier of the module that is actually plugged into the respective slot in the station. Check whether the planned I/O module configuration corresponds with the configuration of the inserted I/O modules by comparing the respective first and second bytes with one another.

The identifier consists of two hexadecimal characters. The first hexadecimal character corresponds to the first decimal number of the I/O module type designation. The second hexadecimal character corresponds to the last two decimal numbers of the I/O module type designation.



Example!

The identifier 2C_{hex} corresponds to I/O module LB2*12 or FB2*12. The first character 2_{hex} corresponds to the first number in the type designation 2*12. The second character C_{hex} corresponds to the last two numbers in the type designation 2*12.

The identifier 35_{hex} corresponds to the I/O module LB3*05 or FB3*05.

In the illustration, you will see two areas marked. The first example shows the identifier 35 35 for slot 3, so the configured I/O module type corresponds with the I/O module that is actually plugged in.

In the second example, 35 45 shows a discrepancy between the configured I/O module (35) and the I/O module plugged in (45). Either replace the I/O module in the remote I/O station or adapt the configuration accordingly to ensure the system functions correctly.

Identifiers for Module Types

Module type identifiers			
Digital I/O modules		Analog I/O modules	
11	LB1*01, FB1*01 digital input	13	LB1*03, FB1*03 frequency/counter input
12	LB1*02, FB1*02 digital input	31	LB3101, FB3201 transmitter power supply, current input
17	LB 1007 digital input	32	LB3*02, FB3*02 HART transmitter power supply, current input
18	LB1*08, FB1*08 digital input	33	LB3103, FB3203 HART transmitter power supply, current input
19	LB1*09, FB1*09 digital input	34	LB3104, FB3204 transmitter power supply, current input
1E	LB1014 digital input	35	LB3*05, FB3*05 HART transmitter power supply, current input
1F	LB1015 digital input	36	LB3*06 HART transmitter power supply
21	LB2*01, FB2*01 digital output with position feedback	41	LB4101, FB4*01 current output
...	...	42	LB4*02, FB4*02 HART current output
2D	LB2*13, FB2*13 digital output with position feedback	44	LB4104, FB4204 current output
61	LB6101, FB6301 relay contact output	45	LB4*05, FB4*05 HART current output
65	LB6005, FB6305 relay contact output	46	LB4106 HART current output
66	LB6006, FB6306 relay contact output	51	LB5*01, FB5201 RTD converter
68	LB6*08, FB6*08 digital output	52	LB5*02, FB5202 thermocouple converter
6A	LB6*10, FB6210 digital output	54	LB5*04, FB5204 RTD converter
...	...	55	LB5*05, FB5205 thermocouple converter
6F	LB6*15, FB6215 digital output	56	LB5*06, FB5206 voltage converter
Special modules			
74	LB7*04, FB7*04 universal input/output (HART)		
00	Empty slot		

7.5.7 Advanced Diagnostics

The **Advanced diagnostics** entry contains status and diagnostic information based on the version.

7.6 "PB Diag. (Hrs.)" Tab

The **PB Diag (Hrs.)** tab displays the PROFIBUS standard diagnostics.

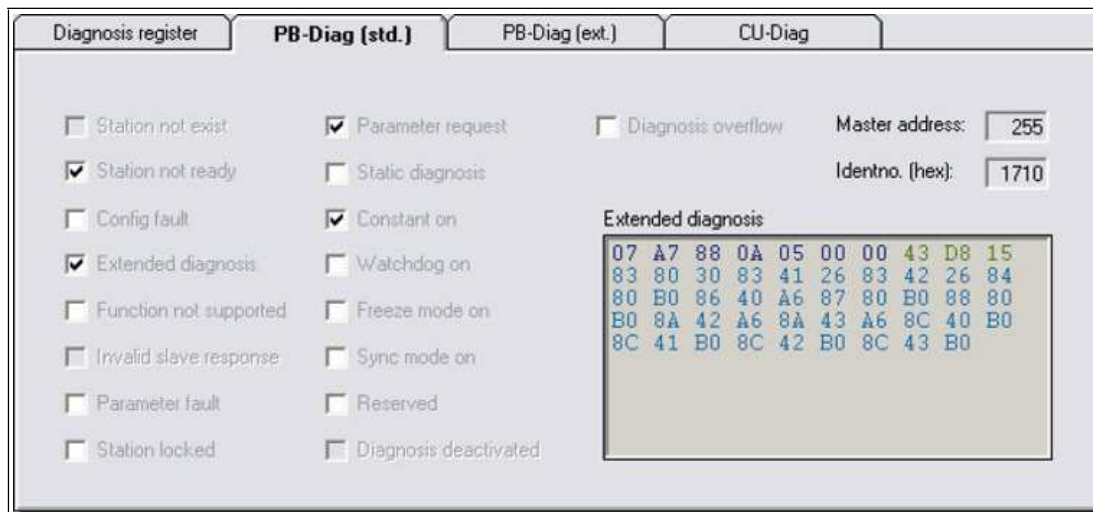

Figure 7.11 **PB Diag. (Hrs)** tab

The PROFIBUS standard diagnostics are generated partly by the master and partly by the slave. The **PB Diag (Hrs.)** tab contains diagnostic data that is read from the slave only. The diagnostic data that the master sets by default only appears as a grayed out check box to display the bit structure of the overall diagnostics. The current states of the master diagnostic bits can only be obtained from the master.

PROFIBUS standard diagnostics byte 1

PROFIBUS standard diagnostics byte 1		
Bit	Diagnostic message	Note/possible cause
0	Station does not exist	Set by the master only. Possible cause: physical bus error (e.g., interruption or short circuit), incorrect slave PROFIBUS address
1	Station not ready	Communication between master and slave is possible, but configuration or parameterization conditions are not yet fulfilled for data exchange (see bit 2 and bit 6).
2	Configuration error	The master and slave configurations do not match. The configured input and output data and the DP configuration string must match in the master and slave.
3	External diagnostics	The slave contains manufacturer-specific diagnostic data.
4	Function not supported	The slave cannot follow a function call.
5	Incorrect slave response	Set by the master if the slave does not transmit the expected response.
6	Parameter fault	Transmitted parameters are incorrect; the slave cannot be switched over to data exchange. Possible cause: transmitted PROFIBUS ID does not match the device.
7	Station blocked/locked	This bit shows that the slave has received correct configuration and parameter data from a master and makes the process data available solely to this master when in <code>DataExchange</code> mode. See the Master Address field for the corresponding master address.

200337 2016-03

PROFIBUS standard diagnostics byte 2

PROFIBUS standard diagnostics byte 2		
Bit	Diagnostic message	Note/possible cause
0	Parameter request	The slave informs the master that the slave requires new parameter data.
1	Statistical diagnostics	If the slave sets this bit, the master only requests diagnostic data and no current process data. Communication remains in the <code>DataExchange</code> state and can therefore transmit process data as soon as the bit is cleared.
2	Constant set	
3	Watchdog function on	The watchdog function is used to monitor communication. We recommend that the watchdog function is always switched on. The function allows the slave to monitor the master and respond to communication problems such as a bus failure where necessary. The slave can activate the substitute value stored for the I/O modules as a response to communication problems.
4	FREEZE mode on	The slave works in FREEZE mode see chapter 7.5.3
5	SYNC mode on	The slave works in SYNC mode see chapter 7.5.3
6	Reserved	
7	Diagnostics off	Diagnostics are not used by the master.

PROFIBUS standard diagnostics byte 3

PROFIBUS standard diagnostics byte 3		
Bit	Diagnostic message	Note/possible cause
0 ... 6	Reserved	
7	Diagnostic data overflow	The slave sets this bit if more diagnostic data exists than can be transmitted, e.g., if too many line faults occur during commissioning.

Following the PROFIBUS standard diagnostic bytes 1 ... 3 are two bytes for the master address (bytes 4 and 5) and two bytes for the PROFIBUS ID (bytes 6 and 7). The values of these bytes are displayed in the **Master Address** and **ID No. (Hex)** fields.

The value under **Master Address** shows which master has blocked the slave (exclusive `DataExchange` access).

ID No. (Hex) shows the PROFIBUS slave ID. For correct data exchange, the slave must be created in the master with its PROFIBUS ID number. On systems where the DTM can be integrated into the master configuration interface, the PROFIBUS ID number is entered automatically. If this is not the case, the correct GSD/GSE file must be integrated in the master.

The remaining bytes in the **Advanced Diagnostics** field (from byte 8 onwards) display the manufacturer-specific diagnostic data for advanced diagnostics. See chapter 7.7

7.7 "PB Diag (Ext.)" Tab

The **PB Diag (Ext.)** tab displays the extended PROFIBUS diagnostic bytes.

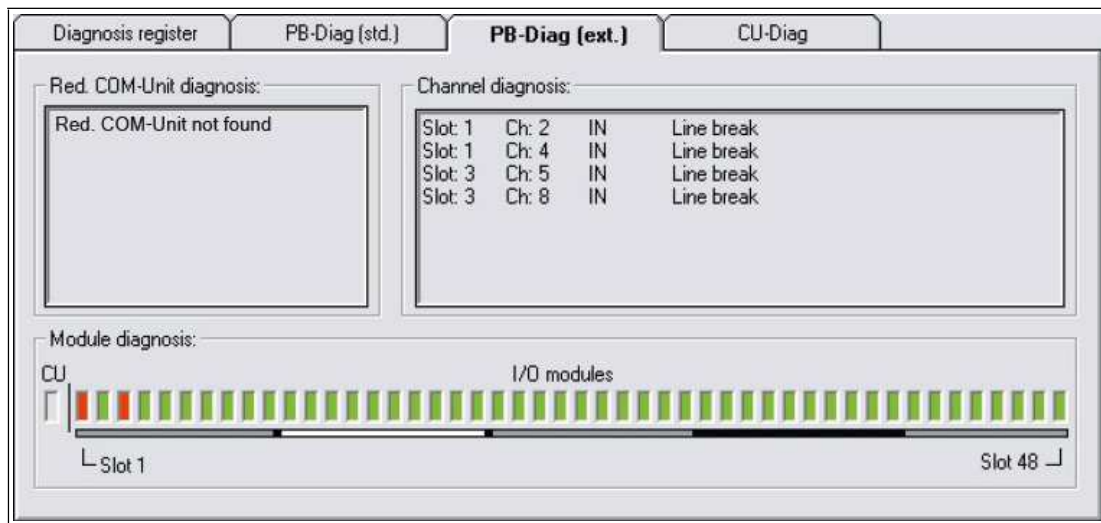

Figure 7.12 **PB Diag. (Ext.)** tab

The **PB- Diag (Ext.)** tab is divided into three areas, which are described in the following section.

Redundancy Com Unit Diagnostics

This area displays a text message evaluating the first two PROFIBUS standard diagnostic bytes of the redundancy com unit (partner com unit). These bytes are transferred during the device-specific diagnostics. See chapter 7.5.2

In contrast to the PROFIBUS standard diagnostics, the com unit sets the **Redundancy Com Unit Not Found** bit if there is no internal communication connection to the redundancy com unit (equivalent to the message **Station Does Not Exist** set by the master).

All other diagnostic messages correspond to the defined PROFIBUS standard diagnostics. See chapter 7.6

Channel Diagnostics

This area shows the channel-specific diagnostics. See chapter 7.5.2

The slot number, channel number, channel type details, and the cause of the error are displayed for every message.

If more diagnostic information is present than can be transferred, the message **Channel Diagnostic Overflow** appears and the text color changes from black to red.

ID/Module Diagnostics

This area shows the module-specific diagnostics. See chapter 7.5.2

A rectangular indicator is assigned to each slot on the Remote I/O station. As soon as diagnostics are available for a slot, the color of the respective rectangle changes from green to red. To display the slot number, position the cursor over the relevant rectangle.

7.8.1 "Com Unit Status Register" Area

ComUnit-Status:		CU-S	GW-S	Cycle	DP-S	Ind.-C.	Error-C.	Diag 1	Diag 2	CRC	FW	Log.
My		E682	C473	DDEA	0000	20	00	0A	05	032013F4	0624	
Partner		xxxx	xxxx	xxxx	xxxx	xxxx	xxxx	xxxx	xxxx	xxxx	xxxx	

Figure 7.14 Com Unit Status area

CU-S (com unit status) field

The box contains the global status register for the com unit.

GW-S (gateway status) field

The gateway status provides information on internal and external communication. The basic data in this field is displayed in the **GW status** area in encoded format. See chapter 7.8.2

Cycle (program cycle counter) field

This field indicates the status of the program cycle counter for the relevant com unit. The value on the counter is not relevant, but the counter must be moving continuously. A moving counter indicates that the program is running.

DP-S field (DP status)

Information relating to PROFIBUS communication is displayed here. The data in this field is displayed in the DP status area in partially encoded format. See chapter 7.8.3

IND C. (indication counter) field

The indication counter monitors PROFIBUS communication and enables the early detection of failures. The respective counter readings are displayed in the **IND. C** fields.

In redundant systems, the counter values must increase uniformly. If one counter starts to run slower than the other or stops running altogether, a PROFIBUS communication failure has occurred on the com unit concerned. If both counter values increase slowly or inconsistently, this does not mean that the process data transmission has failed completely. It is more an indication that a minor communication error has occurred.

In non-redundant systems, a counter that increases uniformly indicates that PROFIBUS communication is working properly.

Error C (error counter) field

The error counter is a component of the additional PROFIBUS monitoring system incorporating the indication counter and draws attention to potential faults by increasing the counter reading. The additional monitoring function is based on estimates relating to the reliability of future PROFIBUS communication. A prognosis resulting in a **fault** must be confirmed several times in succession by the value increasing on the error counter before a preventative redundancy switchover is initiated. The feasibility of switchover is checked first of all. As faults indicated by the error counter are based on prognosis, an increase in the counter value and a switchover to preventative redundancy are not indications that an error has occurred. The error counter is more a tool for increasing availability.

Continuous switching operations by the com units are not permitted and should be investigated.

Diag 1 and Diag 2 (DP diagnosis) fields

The **Diag 1** and **Diag 2** fields display the first two PROFIBUS standard diagnostic octets. A graphic representation of the PROFIBUS standard diagnostic octets is displayed on the **PB Diag (std.)** tab. However, displaying the **PB Diag (std.)** tab is only supported by com units with firmware version 6.19 or higher.

CRC (checksum calculation) field

The result of the checksum calculation is entered here. The checksum calculation ensures that the required data records are stored in the com unit correctly (parameter and configuration data). If the checksums of the com unit and the redundant com unit are identical, the two com units have been correctly synchronized with each other. Identical values mean that the data records are the same. The checksum changes every time a parameter change is successfully transferred, and the modification process is documented as a result.

FW (firmware) field

The field contains the firmware version of the com unit. In redundant systems, make sure that the firmware version of the com unit and redundant com unit is always the same.

7.8.2

"GW Status" Area

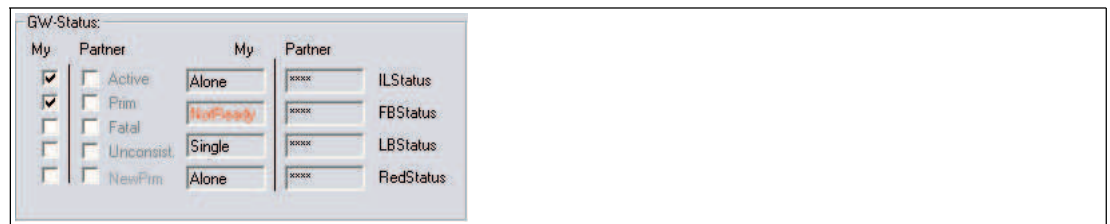

Figure 7.15 GW status area

Active check box (active com unit)

Only one com unit may be active in the remote I/O station at any one time. **Active** indicates which of the two com units is active. In the above illustration, the com unit in the **My** column is active.

Prim (primary com unit) check box

The **Prim** check box allows you to assign data to com unit hardware. Each redundant station has a primary and a secondary com unit slot. In the LB system, the primary slot is the first com unit slot. In the FB system, the primary com unit slot is the com unit slot in the base unit. If, for example, **Prim** is activated in the **My** area, this means that the data in the **My** area represents the com unit in the primary slot.

Fatal (serious error) check box

If the com unit detects a fatal error, this is indicated accordingly by the **Fatal** check box. The com units use error handling routines that are capable of clearing error states. If a fatal error is permanently displayed, or if a fatal error occurs repeatedly, the relevant com unit should be replaced.

Inconsist. (inconsistency) check box

The **Inconsist.** box is used to draw attention to system states that could prevent a redundant remote I/O station from operating correctly. The check boxes are activated in the following situations.

- If the com units have different firmware versions
- If the parameter data of the com units is different
- If both com units are active at the same time
- If both com units are passive at the same time
- If both com units indicate that they are the primary com unit
- If both com units indicate that they are the secondary com unit
- If both com units function as the master on the internal bus
- If both com units function as the slave on the internal bus

Note that short-term inconsistencies are permitted in the startup phase or a transitional phase.

NewPrm (new parameter) check box

This check box is active if the com unit has new parameters. This state is regarded as normal unless it does not clear after a parameterization process.

IL status (internal link status) check box

This box represents the communication path between the two com units. The status can be **Master, Slave, Alone, or Unknown**.

In redundant systems, one com unit must have **Master** status and the other **Slave** status. All other configurations are not allowed. If the **Alone** status is displayed, then the corresponding com unit cannot find its partner, e.g., if the external connection between the two com units is faulty in FB systems.

In non-redundant systems, the status **Alone** is the correct operating status. Here any deviation from the **Alone** status is classed as an error.

FB status (PROFIBUS status) field

This field indicates the status of the PROFIBUS. The status can be

- **Offline:** no PROFIBUS connection available
- **NotReady:** PROFIBUS connection available, but data exchange not possible
- **BadComm:** data exchange possible but malfunctioning
- **Online:** data exchange OK

The status of this field should always be **Online**. If another status is displayed, check the PROFIBUS communication.

Exception: In the case of line-redundant systems, the passive com unit only has read access to the bus and therefore only has limited abilities to maintain communication if a fault occurs. The consequence of this is that the passive com unit briefly loses **Online** status. However, the system automatically sets the passive com unit back to **Online** status after a short time.

LBStatus (internal system bus) field

LBStatus represents the internal system bus between the primary com unit, the secondary com unit and the I/O modules. In addition to start statuses, which are not dealt with in detail here, the **LB status** can display the following statuses.

- **Single:** OK in single systems
- **Alone:** com unit cannot find partner
- **Active:** com unit has bus read-write access
- **Passive:** com unit only has bus read access
- **NoSlots:** no I/O modules can be addressed

If other statuses are displayed permanently, then an error state exists. Note that for proper redundant operation, one com unit must be active and the other must be passive.

RedStatus field

This field contains status details relating to parameter and configuration changes. As part of a change with or without hot configuration in run (HCiR) functionality, the system runs through several individual statuses that will not be described here in detail. The field must show **OK** in normal operation.

If **HCiR** is displayed, a new data record is written to the corresponding com unit, but not yet put into operation by the master. This means that the old data record has not yet been processed and the HCiR process is not yet complete. The **HCiR** status is indicated by the flashing of the green LED on the com unit.

7.8.3 "DP status" area



Figure 7.16 DP status area

The most important information in the **DP status** area is visualized by enabling the **Baud rate** and **DataExch** check boxes. All other information is not suited to user diagnostics and will not be explained here.

Baud rate check box

If **Baud rate** is enabled, the baud rate has been found. If not, a baud rate has not been found.

DataExch check box

If **DataExch** is enabled, process data is transferred. If not, process data is not transferred.

7.9 "Module Status" Tab



Note!

The **Module status** tab is available from DTM version 7.3. The status of the power supplies in the **Power supplies** area is displayed in DTM version 7.5 and higher and depends on the com unit's firmware version.

The **Module status** tab provides an overview of the status of the I/O modules and the power supplies in the overall remote I/O station. Each of the fields in the status/simulation views represents a slot and therefore an I/O module or power supply on the remote I/O station.

The status of the power supplies is only displayed if the firmware of the com unit has a power supply diagnostic function. The power supplies used must also support this diagnostic function.

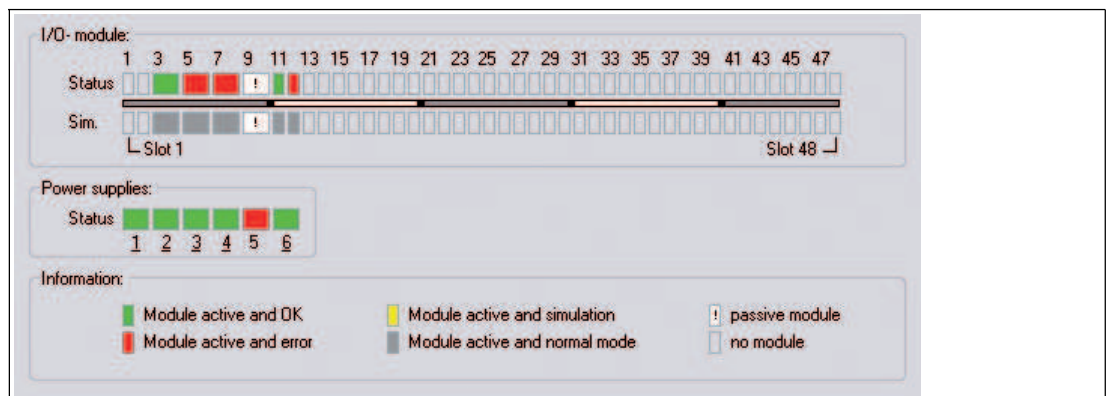

Figure 7.17 Module status tab

The status information is explained on the tab. The I/O module types (display of single/dual width module) and corresponding status areas are requested during each update cycle.

The status of the monitored power supplies is displayed in the **Power Supplies** area. An underlined power supply number indicates that a power supply is available at the relevant position. Power supply monitoring can be activated and deactivated in the com unit device data.



Accessing Information About an I/O Module

You have the option of viewing information about a specific I/O module directly on the **Module status** tab. An active connection to the I/O module may be required, depending on the FDT base application.

1. Right-click on an I/O module in the overview.
2. Access the required information via the context menu.

7.10 PACTware™ Device State Manager

Version 4 and above of PACTware™ includes the **Device State Manager** and **Device State View**. These add-ins enable a cross-device diagnosis based on the NAMUR recommendation NE 107.



Note!

The **Device State Manager** and **Device State View** add-ins may be deactivated. To activate add-ins, select **Extras > Add-ins** in the menu.



Note!

Detailed information on the add-ins described here can be found in the PACTware™ documentation.



Open the Device State Manager window

1. In the project view, right-click on either **HOST PC**, a CommDTM or a com unit.
2. Select **Device State Manager** from the context menu.

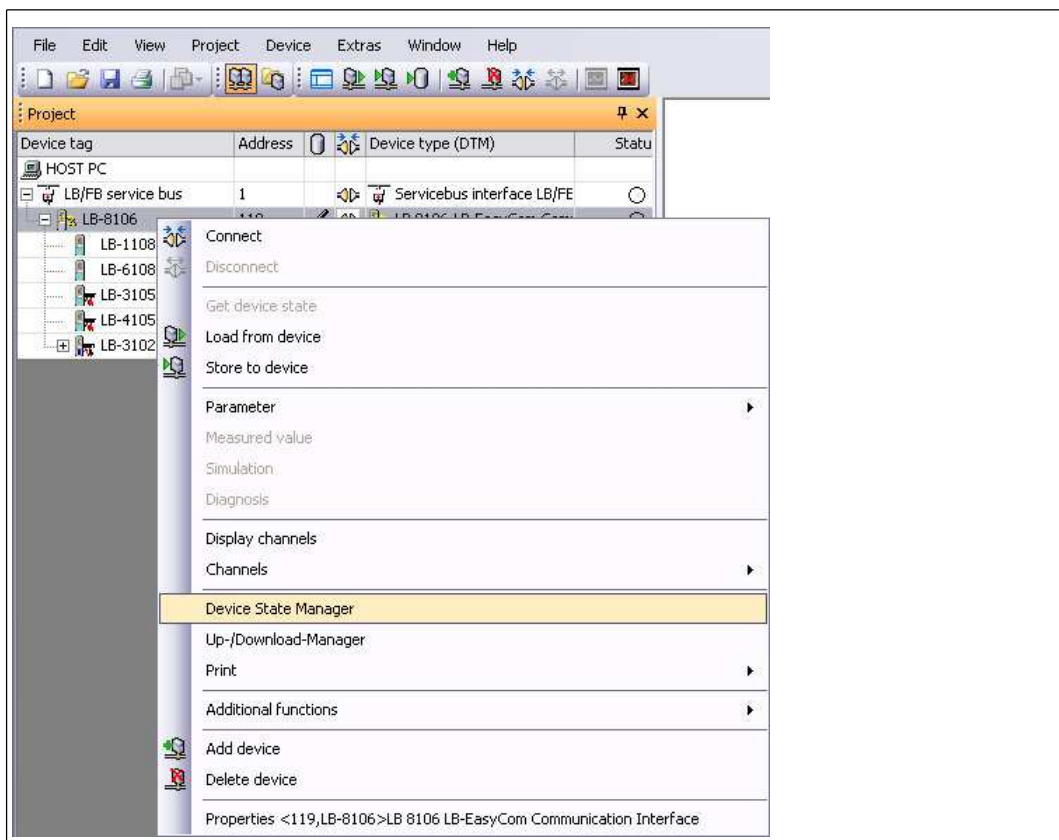

Figure 7.18 Activate Device State Manager

↳ The **Device State Manager** window appears.

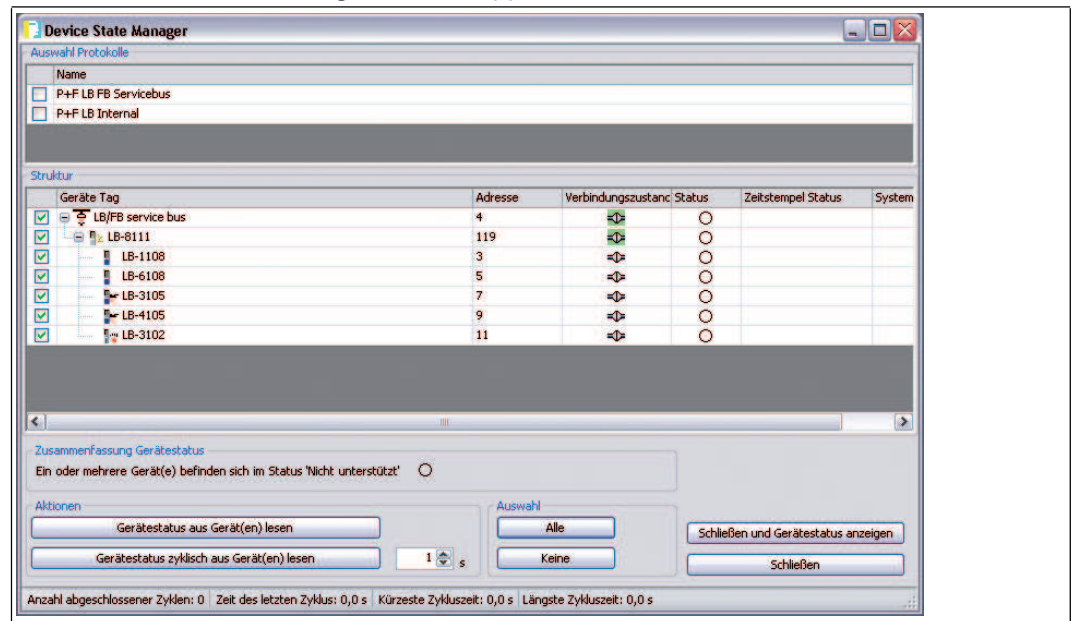

Figure 7.19 Device State Manager window

3. Select the devices that are to be monitored. Use either the check boxes or the buttons in the **Select** area.
4. To read the device status once or at regular intervals, select one of the buttons in the **Actions** area.

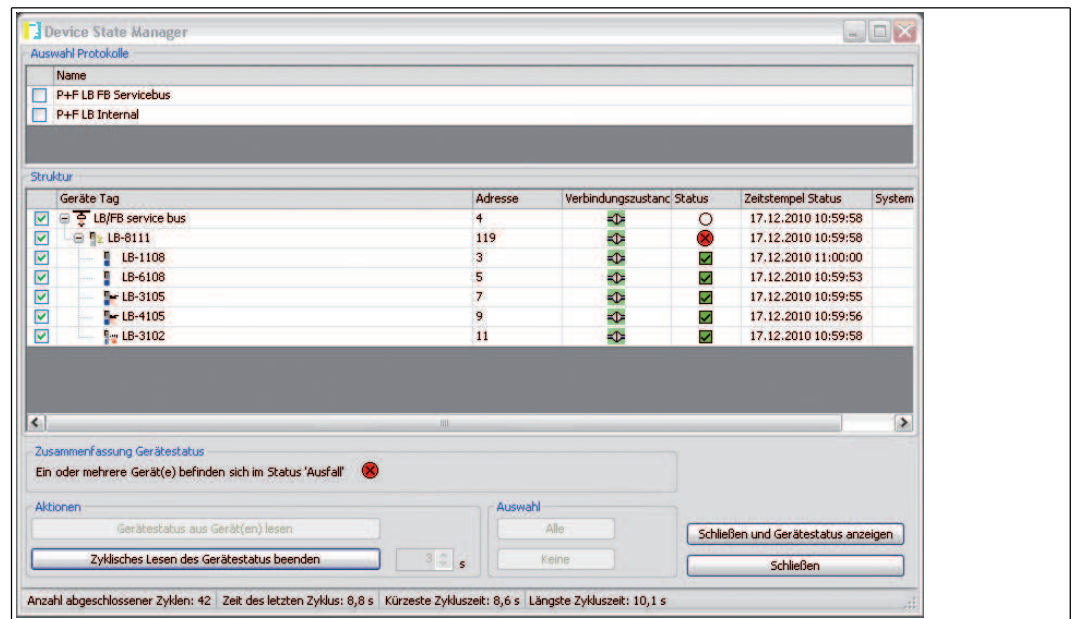

Figure 7.20 Read the device status

↳ A connection to the devices is established and the device status read.

5. Select **Close and Show Device Status**.

↳ The **Device Status** window is displayed. The **Device Status** window contains a list of available status reports. You can filter status reports according to certain criteria and save or delete the list.

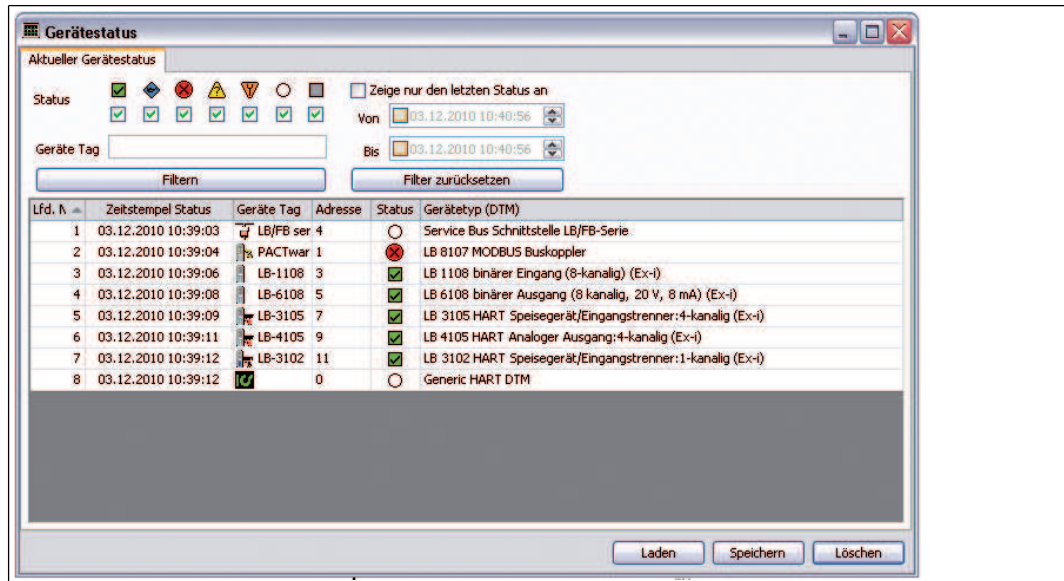

Figure 7.21 Device status window



Note!















Different views for status information

Alternatively, you can open the **Device Status** window via **View > Device Status**. The status symbols are displayed in the project view and the system view.

General meaning of the status symbols in accordance with NAMUR recommendation NE107

Symbol	Meaning
	Active diagnostics
	Passive diagnostics
	Failure
	Function check
	Out of specification
	Maintenance required
	Device status not supported

Specific meaning of the status symbols for remote I/O components

Component	Symbol	Possible meanings
I/O module		Error-free
		Diagnostics switched off (passive I/O module)
		Line fault detection (lead breakage or short circuit)
		I/O module missing
		Incorrect I/O module configured
		Simulation active
		–
		–
	Offline	
Com unit		Error-free
		–
		Field bus communication: no field bus available (for diagnostics scan via service bus only)
		Memory error: PIC/RAM/FLASH
		CPU/PIC fault
		Parameter or arithmetic error
		Redundancy link not available (LB; fault in internal redundancy link)
		–
		Fieldbus communication: fieldbus available, but no data exchange (with PROFIBUS com units only)
		Command error
		Fault in an I/O module
		Fault in power supply
		Redundancy com unit not available
Redundancy link not available (LB; fault in external redundancy link, possibly not connected)		
	Offline	

8 Troubleshooting



Danger!

Risk of explosion

When work is performed on the remote I/O unit in hazardous areas, there is a risk of explosion from spark formation.

Before starting any work on the remote I/O unit, familiarize yourself with the instruction manuals for the components and their relevant certificates.

8.1 Communication error

If there is a communication error, go through the following checklist and take any relevant action.

Fault	Action(s)
Error when communicating with the process control system	<ul style="list-style-type: none"> ■ Check that the cables are connected. ■ In the configuration software, check that the selected address is the same as the Remote I/O station address. ■ Check whether the terminator has been activated. The PROFIBUS must have exactly two terminators per segment; one at the start and one at the end. ■ Check that the bus stations are positioned in linear form and without branches. A star-shaped layout is not permitted. ■ Check that the DP configuration strings of the master and slave are identical. The slave addresses of the master and slave on the fieldbus must be identical. ■ Check that the correct GSD/GSE file is being used.
Communication error on the PROFIBUS	<ul style="list-style-type: none"> ■ In the configuration software, check that the selected address is the same as the Remote I/O station address. ■ Check that the DP configuration strings of the master and slave are identical. The slave addresses of the master and slave on the fieldbus must be identical. ■ Check whether the terminator has been activated. The PROFIBUS must have exactly two terminators per segment; one at the start and one at the end. ■ Check that the bus stations are positioned in linear form and without branches. A star-shaped layout is not permitted. ■ Check the PROFIBUS ID for the Remote I/O station. Some control systems cannot process the GSD/GSE file 0710.
A new Remote I/O station will not work on a bus if other Remote I/O stations are already operating on the bus.	<ul style="list-style-type: none"> ■ Check that the bus terminators are still on the beginning and end of the segment. ■ Check the PROFIBUS ID for the new Remote I/O station.
The software cannot locate a com unit when establishing the connection	<ul style="list-style-type: none"> ■ Check that the yellow LEDs on the com unit are on while the connection is being established. ■ Check that the bus address is within the selected range. If necessary, increase the search range. ■ Check that the com unit is plugged in correctly.

200337 2016-03

Fault	Action(s)
The com unit reports an I/O module error when retrieving saved data from the configuration kit or Remote I/O station.	<ul style="list-style-type: none"> ■ If an I/O module has been installed in the configuration kit or Remote I/O station, this is not an error. The com unit has checked whether any configured I/O modules are available. Install the I/O modules.
Communication error on the service bus after successfully establishing a connection	<ul style="list-style-type: none"> ■ Check that the service bus is galvanically isolated. ■ If you are using a laptop, operate the laptop using a battery. ■ Use a standard interface converter (RS232 to RS485 converter or USB to RS485 converter) with automatic detection of the baud rate and transmission direction.
No HART communication	<ul style="list-style-type: none"> ■ Check that the I/O module in use supports the HART protocol. ■ Ensure that the HART field devices are operating within the permitted operating range of 4 mA ... 20 mA. ■ Check that the correct HART device address was used. ■ Check that the HART software has a DTM for the field device being used. If this is not the case, only basic HART functions will be available.

Fault	Action(s)
FB extension unit not working.	<ul style="list-style-type: none"> ■ Check that the wires on the base unit and extension unit are connected correctly. ■ On redundant systems, check that there is a connection between the extension unit and the redundancy unit.

8.2 Redundancy Faults

If there is a redundancy fault, work through the following checklist and take any relevant action.

Fault	Action(s)
Continuous redundancy switchover	<ul style="list-style-type: none"> ■ Check that the correct type of redundancy is selected (line redundancy or application redundancy). ■ Check that the switchover time been set to a sufficiently long period in the com unit. ■ In FB systems, check whether there is a front connection between the com units. ■ Check that the process control system is configured for this type of redundancy.
No redundancy switchover when a com unit is removed	<ul style="list-style-type: none"> ■ Check that redundancy has been configured at the com unit. ■ Check that there is an electrical connection between the two com units. If not, connect them.
Modules are continuously changing the data	<ul style="list-style-type: none"> ■ Check whether one of the com units has not been configured for redundancy mode. If this is the case, both com units actively try to access the I/O modules and interfere with each other.

8.3 Faults Indicated by LEDs

Fault elimination is supported by a series of LEDs on the com unit, the I/O modules, and the power supply. If the LEDs indicate an error, work through the following checklist and take any relevant action.

Depending on the load, the output circuit may show a lead breakage due to overload. With solenoid valves, this can result in their input resistance being outside the lead breakage detection range. In such cases, connect a high value resistor in parallel to improve the function.

If short-circuit detection is triggered with booster valves, the charging capacitor may be the cause of the error. If this is the case, connecting a small resistor in series may correct this behavior. If necessary, deactivate line fault detection.

LEDs on com units	
Fault	Action(s)
Red LED (2) on com unit is on	Collective error: there is a problem with at least one component (I/O module, power supply, or com unit). <ul style="list-style-type: none"> ■ Check all slots for I/O modules with red LEDs on. All red LEDs must be turned off, otherwise the com unit will continue to report an error. ■ Make sure that all configured components are plugged in and ready for operation (green LED on). ■ Check the global status register in the com unit measured value display to determine the cause of the collective error message.
Yellow LED (5) on the com unit is flashing without the bus being connected	<ul style="list-style-type: none"> ■ The com unit is ready for operation and working with the I/O modules.
Yellow LED (5) on the com unit is flashing at long intervals	<ul style="list-style-type: none"> ■ The com unit is ready for operation and working with the I/O modules. At least one I/O module is in simulation mode.
Fieldbus	
Yellow LEDs (3, 6) on the com unit are showing no activity while communication is being established (LEDs = off)	<ul style="list-style-type: none"> ■ Check that the physical connection between the configuration tool and the remote I/O station was established correctly.
Service bus	
Yellow LEDs (4, 7) on the com unit are flashing while communication is being established via the service bus	<ul style="list-style-type: none"> ■ Check that the configuration cable and the adapter are connected properly.

LEDs on I/O modules and power supplies	
Fault	Action(s)
Red LED on an I/O module is on	<ul style="list-style-type: none"> ■ Check that the field wiring is connected correctly. ■ Check that the sensor is working properly. ■ Check that the field devices are working properly.
Red LED on an I/O module is flashing	<p>No communication between the I/O module and the com unit.</p> <ul style="list-style-type: none"> ■ Check that the I/O module is plugged into the backplane properly. ■ Make sure that the connector pins are not bent. ■ Plug a different I/O module into this slot. If the new I/O module also does not work (red LED flashing), the fault may lie with the backplane.
Yellow LEDs on I/O modules are on	<ul style="list-style-type: none"> ■ For digital inputs, the yellow LEDs provide various status indicators. ■ For transmitter power supplies, the yellow LED indicates that operation is outside the normal range.
Green LEDs on all I/O modules are off	<ul style="list-style-type: none"> ■ Check that the power supply is connected to the backplane correctly. ■ Check that the power supply is working and is plugged into the backplane properly.
Green LED on one I/O module is off	<ul style="list-style-type: none"> ■ Check that the I/O module is plugged into the backplane properly. ■ If necessary, replace the I/O module. ■ If the problem persists, check that the backplane is working correctly.
Green LED on power supply is off	<ul style="list-style-type: none"> ■ Check that the correct voltage is connected to the power supply unit. ■ Check that the power supply is plugged into the backplane correctly and that it is making contact with the backplane. ■ Check the supply voltage. Under maximum load, the 24 VDC voltage must not drop below 20 V including any ripple voltage. ■ The fuse may have blown. FB power supplies do not contain any replaceable fuses and must be replaced with a new FB power supply.

8.4 Signal Fault

Deactivated I/O Modules

Deactivated I/O modules are often used for subsequent extensions. Before deactivating the I/O module, switch off its line fault detection. This prevents the I/O module from triggering an alarm if the com unit launches a query to verify whether an I/O module is installed in that slot.

Fault	Action(s)
No signal change when the parameters are changed	<ul style="list-style-type: none"> ■ Check whether the I/O module is in operation. ■ Check that the change in the Remote I/O station has been saved. ■ Download the parameterization to determine the current parameterization of the I/O module. ■ PROFIBUS com unit: check whether Hot Configuration in Run (HCiR) is active. If yes, the new setting will only be active after a HCiR switchover in the master.
Faulty signal	<ul style="list-style-type: none"> ■ Check if there is a short circuit or lead breakage within the circuit. ■ Check that the field devices and sensors are working properly. ■ If necessary, replace the I/O module. ■ Check the signal path to the I/O module.
All signals for a station are faulty	<ul style="list-style-type: none"> ■ Check that the power supply is working properly. ■ Check the bus connection. ■ Check the bus communication. ■ Use a bus monitor.
Output module switches to substitute values	<ul style="list-style-type: none"> ■ Check the settings for the watchdog on the com unit. The duration for the transition to replacement values must be longer than the duration of a bus cycle.
The output module turns off	<p>Communication with the com unit is interrupted.</p> <ul style="list-style-type: none"> ■ Check that the I/O module is plugged into the backplane properly. ■ If necessary, switch off the status bits for analog outputs.
Input module delivers no measured values sporadically	<p>Communication with the com unit is interrupted.</p> <ul style="list-style-type: none"> ■ Check that the I/O module is plugged into the backplane properly.
I/O module works fine in a certain slot but not in another	<ul style="list-style-type: none"> ■ Check that the connector is in good order on the faulty slot and that the I/O module pins are not bent. ■ If necessary, do not continue to use the slot.
Measured values occasionally incorrect	<ul style="list-style-type: none"> ■ Check whether the measured value is being distorted by external influences. ■ Check that the shielding is intact.
Signal does not change	<ul style="list-style-type: none"> ■ Check if simulation mode is activated for the channel (not for com units LB8*06 or FB8*06). ■ Check if the substitute value is active, because there is no bus communication. ■ Check if there is a line fault.
I/O module not issuing any diagnostic messages	<ul style="list-style-type: none"> ■ Check whether line fault detection is active. If not, activate line fault detection. ■ Check if the expected diagnostic information has been activated in the com unit (PROFIBUS com unit: additional module diagnostics).

Fault	Action(s)
No input/output data	<ul style="list-style-type: none"> ■ Check that the correct I/O module is connected and ready for operation. ■ Check that the analog input/output scaling is compatible with the system requirements. ■ Check that the wiring is in order.
I/O module reported to be faulty	<ul style="list-style-type: none"> ■ Check that the correct I/O module is plugged in. ■ Check that the green LED on the I/O module is lit and that the I/O module is correctly plugged in.
Module fault	<ul style="list-style-type: none"> ■ Check that the green LED on the I/O module is lit. If not, there is no contact with the backplane or the fuse is faulty. If all the I/O modules in a segment have failed, the fault is in the power supply or the backplane. ■ Using the measured values display, check the I/O module diagnostic information.

Fault	Action(s)
6/8 LB modules fail simultaneously (backplanes LB9121, LB9101).	<ul style="list-style-type: none"> ■ Check that the power supply to the segment is working correctly.

Fault	Action(s)
24 FB modules fail simultaneously.	<ul style="list-style-type: none"> ■ Check that the power supply is working perfectly. ■ Check that the extension wiring is correct and intact.

8.5 Faults and their effects

The table below shows what effect different faults will have.

Fault	Diagnostics	Effect
FB power supply failure (redundant)	<ul style="list-style-type: none"> ■ The master receives an error message in the global status register, provided this facility has been preconfigured. ■ The master also receives a redundancy error message. 	<ul style="list-style-type: none"> ■ Redundancy switchover from primary to redundant com unit.
FB power supply failure (non-redundant)	<ul style="list-style-type: none"> ■ The master receives 24 error messages in the global and module status register, provided this facility has been preconfigured. ■ The master receives 24 module-specific and channel-specific error messages if module diagnostics have been enabled. 	<ul style="list-style-type: none"> ■ 24 I/O modules are lost.

Fault	Diagnostics	Effect
Power supply failed (redundant remote I/O station)	<ul style="list-style-type: none"> The master receives an error message in the global status register, provided this facility has been preconfigured (only with LB9022 and LB9024 backplanes). 	<ul style="list-style-type: none"> Backplanes LB9022, LB9024, and LB9029: With 2 out of 3 redundancy when using 3 LB9006 power supplies, full functionality is retained even in the event of a power supply failure. Backplanes LB9121 and LB9101: When using 2 LB9104 power supplies, 8 I/O modules fail as soon as a power supply fails. However, the com units continue to be supplied by the functioning power supply, so communication is maintained.
Power supply failed (non-redundant remote I/O station)	<ul style="list-style-type: none"> The master receives 8 error messages in the global and module status register, provided this facility has been preconfigured. The master receives 8 module-specific and channel-specific error messages if module diagnostics have been enabled. 	<ul style="list-style-type: none"> Backplanes LB9022, LB9024, and LB9029: Only two power supplies are generally used in non-redundant use. This means that in the event of a power supply failure, the whole station may be affected (depending on the number of I/O modules being used). Backplanes LB9121 and LB9101: When using 2 LB9104 power supplies, 8 modules fail as soon as a power supply fails. However, the com unit continues to be supplied by the functioning power supply, so communication is maintained.

Fault	Diagnostics	Effect
Bus communication failed	<ul style="list-style-type: none"> The master detects the failure. 	<ul style="list-style-type: none"> The outputs adopt substitute values provided this facility has been preconfigured.
Com unit or voltage failed	<ul style="list-style-type: none"> The master detects a faulty slave. 	<ul style="list-style-type: none"> The outputs have no voltage unless the system is redundant in design.

Fault	Diagnostics	Effect
I/O module failed	<ul style="list-style-type: none"> ■ The master receives an error message in the global and module status register, provided this facility has been preconfigured. ■ The master receives the Module error message if module diagnostics have been activated. 	<ul style="list-style-type: none"> ■ No signal change. The inputs adopt substitute values provided this facility has been preconfigured. ■ The output has no voltage. ■ In most cases the green LED is off. There are cases, however, when the green LED is on despite an error.
Incorrect I/O module	<ul style="list-style-type: none"> ■ The master receives an error message in the global and module status register, provided this facility has been preconfigured. ■ The master receives the Incorrect module message if module diagnostics have been activated. 	<ul style="list-style-type: none"> ■ No signal change. The inputs adopt substitute values provided this facility has been preconfigured. ■ The output has no voltage. ■ The red LED in the dual width I/O module is flashing.
I/O module missing or has been removed	<ul style="list-style-type: none"> ■ The master receives an error message in the global and module status register, provided this facility has been preconfigured. ■ The master receives the Missing module message if module diagnostics have been activated. 	<ul style="list-style-type: none"> ■ The input is frozen. ■ The output has no voltage.
Module-specific errors		
Line fault in the input module	<ul style="list-style-type: none"> ■ The master receives an error message in the global and module status register, provided this facility has been preconfigured. ■ The master receives an Invalid data error message if module diagnostics have been activated. 	<ul style="list-style-type: none"> ■ The red LED is on. ■ No signal change. The inputs adopt substitute values provided this facility has been preconfigured. ■ Temperature inputs only return to normal operation once the error has been corrected and the LFD delay has lapsed.

Fault	Diagnostics	Effect
Range overflow or underflow in I/O modules LB3101, FB3201, LB3*02, FB3*02, LB3103, FB3203, LB3104, FB3204, LB3*05, FB3*05	<ul style="list-style-type: none"> ■ The master receives an error message in the global and module status register, provided this facility has been preconfigured. ■ The master receives an Invalid data error message if module diagnostics have been activated. 	<ul style="list-style-type: none"> ■ The yellow LED is on. ■ The signal is limited to the predefined trip values.
Line fault in I/O modules LB2002, LB21*, FB22*, LB4101, FB4*01, LB4*02, FB4*02, LB6*08, FB6*08	<ul style="list-style-type: none"> ■ The master receives an error message in the global and module status register, provided this facility has been preconfigured. ■ The master receives an Invalid data error message if module diagnostics have been activated. 	<ul style="list-style-type: none"> ■ The red LED is on. ■ The output has no voltage.

PROCESS AUTOMATION – PROTECTING YOUR PROCESS



Worldwide Headquarters

Pepperl+Fuchs GmbH
68307 Mannheim · Germany
Tel. +49 621 776-0
E-mail: info@de.pepperl-fuchs.com

For the Pepperl+Fuchs representative
closest to you check www.pepperl-fuchs.com/contact

www.pepperl-fuchs.com

Subject to modifications
Copyright PEPPERL+FUCHS • Printed in Germany

 **PEPPERL+FUCHS**
PROTECTING YOUR PROCESS

200337 / TDOCT-1222FENG
03/2016