

**Southeast Toyota Distributors, LLC
Accessory Installation Instructions**

**2020 RAV4
WIRELESS CHARGER TRAY**

Recommended Tools

Year & Model:	2020 RAV4
Part Number:	00016-42506
Accessory Code:	CW1000
PIO / DIO:	PIO & DIO
Business Partner:	J56

Safety Items	
Safety Glasses	Safety Gloves
Special Tools	
Installation Tools	
Padded Work Surface	Protective Blanket
Moulding Remover	Pliers
Ratchet/Driver	Side Cutters
Socket (10mm)	Torque Wrench (48 in*lbs)
Small Slotted Screwdriver	Masking Tape
Special Chemicals	
N/A	

Conflicts

Note: Technology Package

General Applicability

FitsModels:	
1.	All Models
2.	
3.	

Additional Items Required For Installation

Item#	Description:
1	N/A
2	

Sequence of Application

Item#	Accessory:
1	N/A
2	

SPECIALNOTE: InstallationSequences

After TMS & Safety mandated preparatory steps have been taken, the installation sequence is the suggested method for completing the accessory installation. In some instances the suggested sequence is written for one associate to install & in others the sequence is given as part of a team accessory installation. Unless otherwise stated in the document, the associates may perform the installation steps in any order to make the installation as efficient as possible while maintaining consistent quality.

Legend

	STOP: Damage to the vehicle may occur. Do not proceed until process has been complied with.
	OPERATOR SAFETY: Use caution to avoid risk of injury.
	CAUTION: A process that must be carefully observed in order to reduce the risk of damage to the accessory/vehicle and to ensure a quality installation.
	TOOLS & EQUIPMENT: Used in figures calls out the specific tools and equipment recommended for this process.
	REVISION MARK: This mark highlights a change in installation with respect to previous issue.
	SAFETY TORQUE: This mark indicates that torque is related to safety.
	REGULATORY MARK: This mark indicates that the component is related to regulatory compliance.
	VIDEO: This image indicates a video to show a installation procedure, PIO Only.

Document History Revisions

Version	Date	Description of Changes Made
Ver. 1	06/19/2020	Document Published
Ver. 2	06/29/2020	Assure the USB port is in the proper orientation, step 11, pg. 13
Ver. 3	07/01/2020	Update pg. 9 step (a. & b.) Update pg. 18 step (a) for proper procedure. Update Function pg. 20 to read Blue, Red, Green in quick succession.

Table of Contents

I. Preparation.....1-6

 a. History of Revisions.....2

 b. Table of Contents..... 3

 c. Kit/Hardware & Wire Harness Bag Contents..... 4

 d. Parts for Installation.....5

 e. Service & Warranty Information 6

II. Procedures

 a. Battery Removal.....7

 b. Vehicle Disassembly – Installation Process..... 8-18

III. Re-install Battery..... 19

IV. Function and Quality Checks..... 20

V. Diagnostic / Block Diagrams & Connector Procedures.....21-23

VI. Blank Page..... 24

VII. Warranty Statement..... 25-26

Kit & Hardware Bag Contents:

Item #	Quantity	Description
1.	1	Wireless Charger Tray Assembly & Pigtail Harness
2.	1	Wireless Charger "T" Harness
3.	3	Zip Ties 8"
4.	1	User Manual

Parts for Installation:

Care must be taken when installing this accessory to ensure damage does not occur to the vehicle. The installation of this accessory should follow approved guidelines to ensure a quality installation. These guidelines can be found in the “Accessory Installation Practices” document.

This document covers such items as:

- Vehicle Protection (use of covers and blankets, cleaning chemicals, etc.).
- Safety (eye protection, re-checking torque procedure, etc.).
- Vehicle Disassembly/ Reassembly (panel removal, part storage, etc.).
- Electrical Component Disassembly/Reassembly (battery disconnection, connector removal, etc.).

Item #	Quantity	Description
1.	1	Wireless Charger Tray Assembly & Pigtail Harness
2.	1	Wireless Charger “T” Harness
3.	3	Zip Ties 8"
4.	1	User Manual

1.



2.



3.



4.



Service & Warranty Information:

Image Key	Parts Information		Warranty Information	
	Part Number	Description	Warranty Time	Labor Op. Code
A	00016-42506	Wireless Charger Tray Kit	0.5	ACW001

Labor times include consideration for diagnosis and Administration time.
 If you are a dealer located outside of the Southeast Region, please contact the SET Accessory Warranty Department at (888) 851-2722 or email Accessory.Warranty@SETToyota.com for claim payment instructions.

Parts:

A – Wireless Charger Tray Kit





Figure 1-1

BATTERY REMOVAL

Prepare for the Installation:

- (a) The engine components and coolant may be hot.
- (b) Check the kit for contents and any damage.
- (c) Protect the fender.

Note: For Gas vehicles, the battery is in the engine compartment.

For Hybrid vehicles, the battery is in the cargo area.

Remove the battery cover by disengaging the claws. Figure 1-1.



Figure 1-2



Do not disconnect the terminal at the 12mm nut.



Use 10mm socket.

1. Remove the NEGATIVE (-) battery terminal by loosening the 10mm terminal nut before starting any disassembly. Figure 1-2.
2. Place insulator over negative battery terminal.



DO NOT touch the positive terminal.



Wait at least 90 seconds after disconnecting the cable from the negative (-) battery terminal to disable the SRS system.

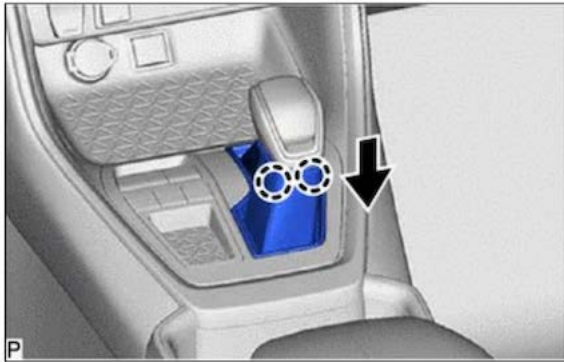

Figure 2

**VEHICLE DISASSEMBLY-
INSTALLATION PROCESS**



Place a protective blanket in the front console work area.

3. REMOVE SHIFT LEVER KNOB SUB-ASSEMBLY

(a) Disengage the 2 claws to disconnect the shifting hole cover sub-assembly as shown in the illustration. Figure 2.

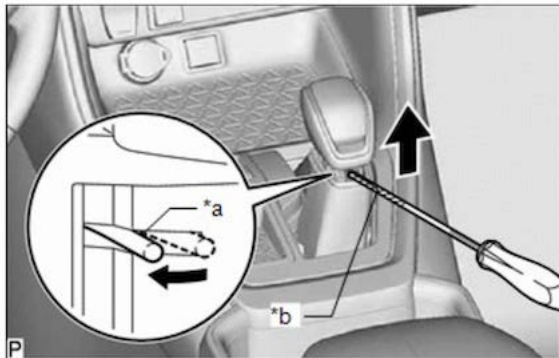

*a	Clip
*b	Protective Tape

Figure 3

**4. REMOVE REAR CONSOLE END
PANEL SUB-ASSEMBLY**



Use a small slotted screwdriver with its tip wrapped with protective tape to avoid damaging the part.

(a) Using a screwdriver with its tip wrapped with protective tape, expand the left side of the clip and remove the shift lever knob sub-assembly from the transmission floor shift assembly as shown in the illustration. Figure 3.



Shift Lever Knob & Retaining Clip

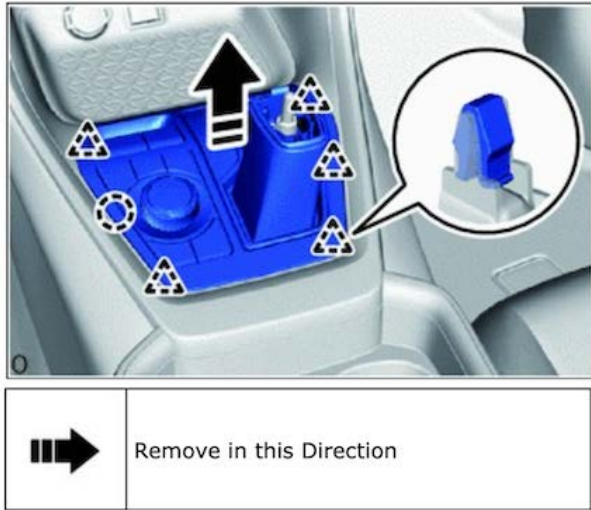

Figure 4



Figure 5

5. REMOVE UPPER CONSOLE PANEL SUB-ASSEMBLY

(a) Lift up in the direction indicated by the arrow shown in the illustration to detach the claw and clip and partially remove the upper console panel sub-assembly. Figure 4.

(b) Disconnect the 2 connectors & assure the upper console panel sub-assembly has a protective cover underneath it and there is no tension on the wires. Fig. 5 as shown.



	Remove in this Direction (1)
	Remove in this Direction (2)

Figure 6

6. REMOVE UPPER CONSOLE BOX (w/o Wireless Charger)

- (a) Rotate in the direction indicated by the arrow (1) shown in the illustration to detach the clip. Figure 6.
- (b) Pull in the direction indicated by the arrow (2) shown in the illustration to detach the guide and remove the upper console box.

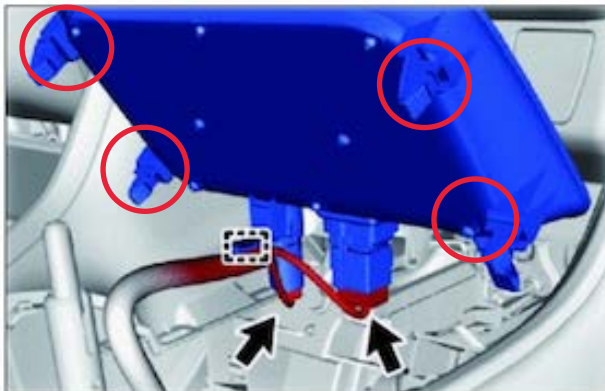



Figure 7

- (a) Detach the clamp and disconnect the 2 connectors. Figure 7.

Note: Remove 4 Red clips from tray and install them onto the new wireless charging tray. Fig. 7



Figure 8

 Perform these steps on a padded surface to avoid damaging the part. Figure 8.

7. REMOVE POWER OUTLET & FRONT USB CHARGER ASSEMBLIES FROM UPPER CONSOLE BOX

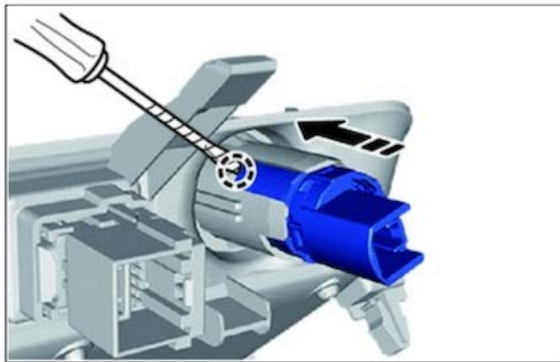





	Protective Tape
	Remove in this Direction

Figure 9

  Use a small slotted screwdriver with its tip wrapped with protective tape to avoid damaging the part.

8. REMOVE NO. 1 POWER OUTLET SOCKET ASSEMBLY
 - (a) Using a screwdriver with its tip wrapped with protective tape, detach the claw and remove the No. 1 power outlet socket assembly as shown in the illustration. Figure 9.

- 9. REMOVE NO. 1 POWER OUTLET SOCKET COVER
(a) Detach the claw and guide to remove the No. 1 power outlet socket cover. Figure 10.

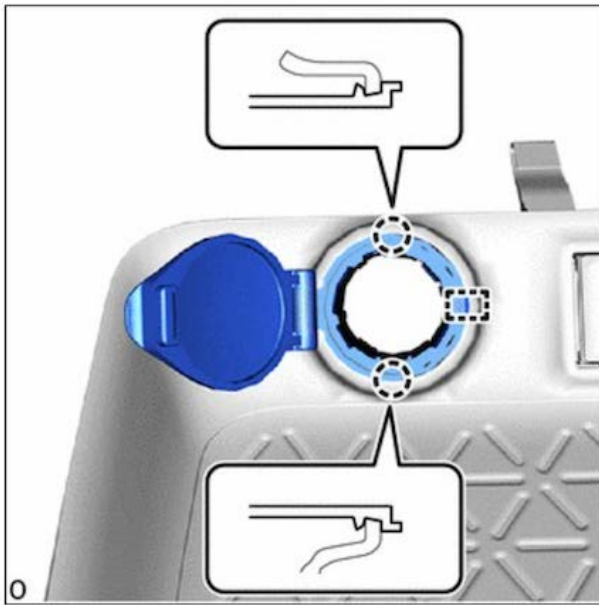

Figure 10

- 10. REMOVE FRONT USB CHARGER ASSEMBLY
(a) Detach the claw and remove the Front USB Charger assembly as shown in the illustration. Figure 11.
(b) Transfer the removed components to the work area next to Wireless Charger Tray.

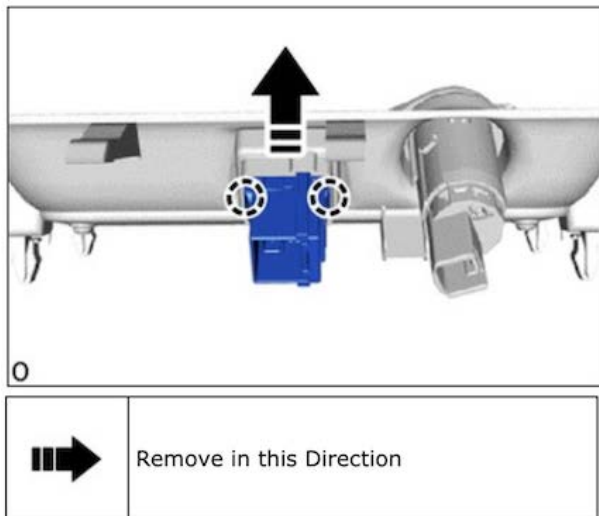

Figure 11

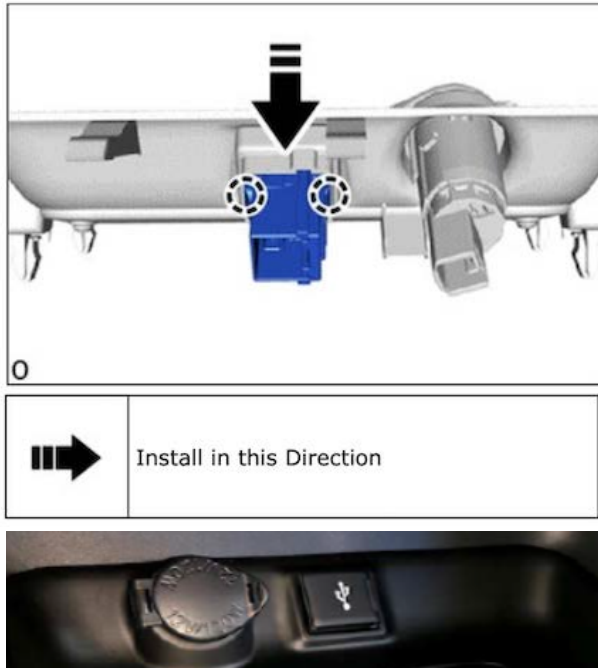

Figure 12

11. INSTALL FRONT USB CHARGER ASSEMBLY INTO WIRELESS CHARGER TRAY

(a) Attach the claw to install the Front USB Charger assembly as shown in the illustration. Assume the USB port is in the proper orientation. Figure 12.

12. INSTALL NO. 1 POWER OUTLET SOCKET COVER INTO WIRELESS CHARGER TRAY

(a) Attach the guide and claw to install the No. 1 power outlet socket cover. Remove and retain clips. Figure 13.

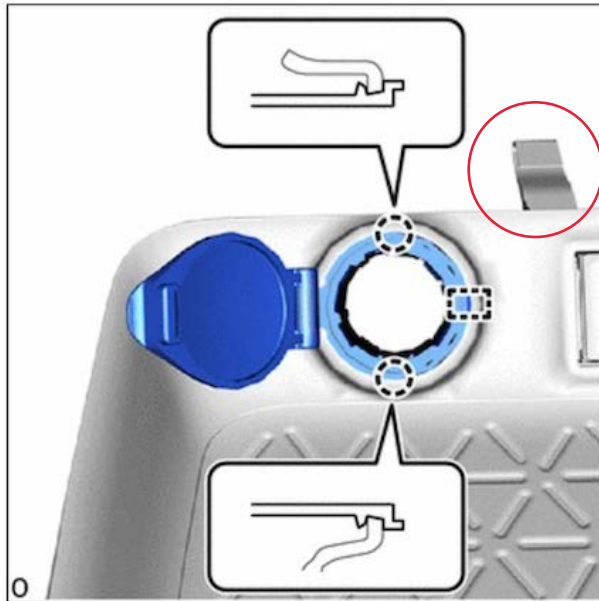

Figure 13

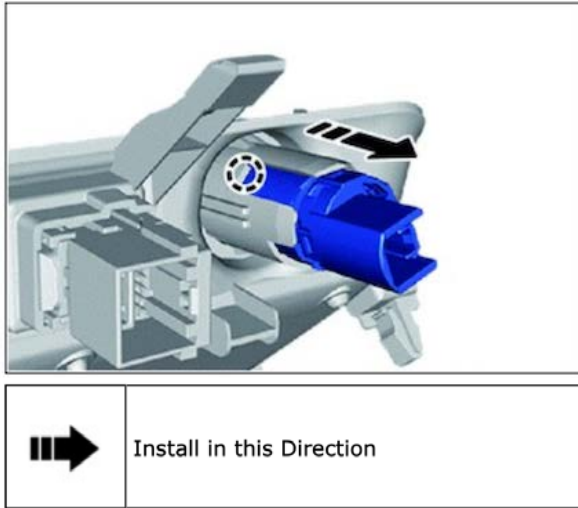

Figure 14

13. INSTALL NO. 1 POWER OUTLET SOCKET ASSEMBLY INTO WIRELESS CHARGER TRAY

(a) Attach the claw to install the No. 1 power outlet socket assembly as shown in the illustration. Figure 14.



Figure 15

14. ATTACH NO. 1 POWER OUTLET SOCKET ASSEMBLY INTO WIRELESS CHARGER TRAY

(a) Connect male Power Outlet connector of the Wireless Charger Tray's "T" wire harness to the No. 1 Power Outlet connector shown by the red circle. Figure 15.



Figure 16

15. CONNECT THE WIRELESS CHARGER TRAY PIGTAIL TO THE T HARNESS

(a) Connect the Wireless Charger Tray Pigtail's male connector (C4) to the T Harness female connector (C1) as shown by the red circle. Figure 16.



Figure 17



Use one (1) 8" zip tie.

16. Bundle & secure the Wireless Charger Tray's "T" harness as shown with one (1) zip tie. Figure 17.



Ensure that the 3A Mini inline fuse is secure yet accessible for service.

- (a) Snip excess zip tie length.
- (b) Move the Wireless Charger Tray assembly back to the front console installation location.

INSTALL WIRELESS CHARGER TRAY:

17. Locate the BROWN USB Charger & BLACK (G22) Power Outlet connectors that were previously disconnected in Step #5b. Figure 18.



Figure 18

18. Connect the male BROWN USB Charger harness connector to USB Charger assembly as shown by the LH red circle. Figure 19.
19. Connect the Wireless Charger Tray's female Power Outlet connector (C2) to the vehicle's male Power Outlet harness connector (G22) as shown by the RH red circle. Figure 19.



Figure 19



Figure 20



Use one (1) 8” zip tie.

20. Bundle & secure the Wireless Charger Tray’s “T” harness to the factory harness as shown with one (1) zip tie. Figure 20.



Ensure that the 3A Mini inline fuse is secure yet accessible for service.

- (a) Snip excess zip tie length.
- (b) Carefully push the wire harness bundle back into the opening so that it does not interfere with the Wireless Charger Tray Assembly.



Figure 21

21. INSTALL WIRELESS CHARGER TRAY ASSEMBLY

- (a) Insert in the direction indicated by the arrow (1) shown in the illustration to attach the guide.
- (b) Rotate in the direction indicated by the arrow (2) shown in the illustration to attach the clip and install the upper console box. Figure 21.

	Install in this Direction (1)
	Install in this Direction (2)

22. INSTALL UPPER CONSOLE PANEL SUB-ASSEMBLY

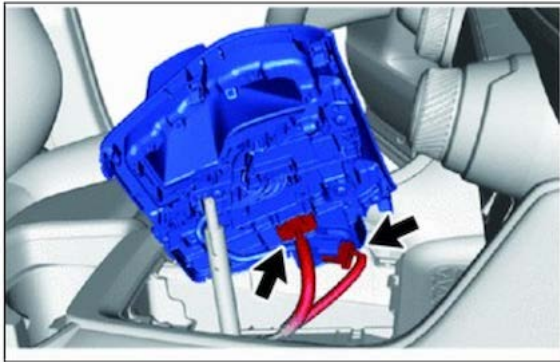

Figure 22

- (a) Connect the 2 connectors. Assure the connectors have no stain on the connectors. Figure 22.



- (b) Attach the claw and clip to install the upper console panel sub-assembly. Figure 23a.

Figure 23a

23. INSTALL SHIFT LEVER KNOB SUB-ASSEMBLY, Figure 23b.

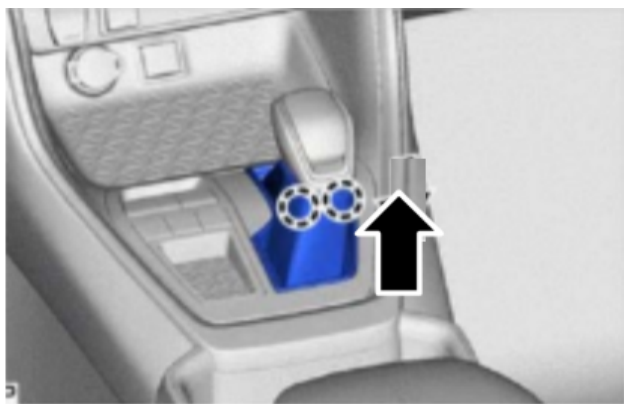

Figure 23b



Figure 27

24. RE-INSTALL BATTERY



Use 10mm socket & torque wrench.

(A) Reconnect the negative battery cable.
Figure 27.



Torque: 48 in•lbs [5.4 N•m]



Caution: DO NOT touch the positive terminal.



When disconnecting the cable, some systems need to be initialized after the cable is reconnected.

(B) Print Warranty Statement and place in the glove box, DIO only.



Figure 28



Test the Wireless Charger Tray function to ensure a quality installation.

(C) Perform the Function & Quality checklist.

FUNCTION AND QUALITY CHECK

CHECKLIST - these points MUST be checked to ensure a quality installation.

ACCESSORY FUNCTION CHECK:

LOOK FOR:

 Turn ignition (ACC power) to On.

Wireless Charger's LED Lights (Power Button & Tray) cycle through **BLUE,RED** then **GREEN** in quick succession:

> Power ON STANDBY – GREEN

No.1 Power Outlet supplies power

Front USB Port supplies power

 User Manual

Place User Manual in the glove box

 Warranty Statement

Place SET Warranty Statement in glovebox – DIO Only

Diagnostic / Block Diagrams & Connector Procedures:

CONNECTOR G22: No. 1 Power Outlet Socket Assembly

Location: Front console

G22
Black

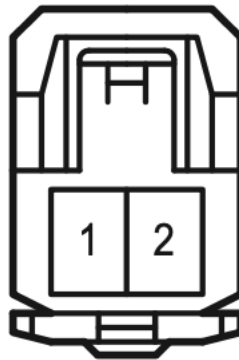

Diagnostic / Block Diagrams & Connector Procedures:

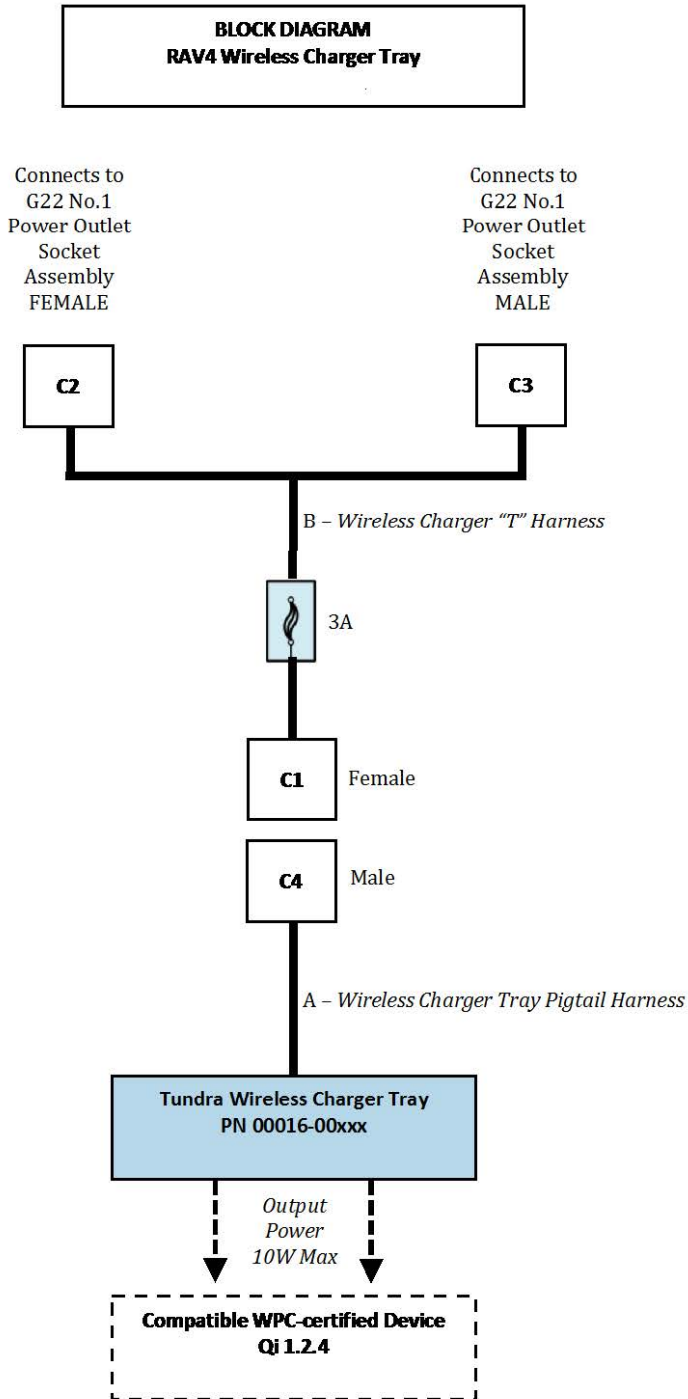

Diagnostic / Block Diagrams & Connector Procedures:**Connector C1 - Wireless Charger "T" Harness (Female)**

Pin	Wire Color	Test Reference	Proper Operation
1	Black	Pin 1 to Ground	Approximately 0 VDC
2	Red	Pin 2 to Ground	Approximately 0 VDC when ignition is OFF +12 VDC when ignition is ACC or ON

**Connector C4 - Wireless Charger Tray Pigtail Harness (Male)**

Pin	Wire Color	Test Reference	Proper Operation
1	Black	Pin 1 to Ground	Approximately 0 VDC
2	Red	Pin 2 to Ground	Approximately 0 VDC when ignition is OFF +12 VDC when ignition is ACC or ON

**Connector C2 - Wireless Charger "T" Harness to G22 Female Connector**

Pin	Wire Color	Test Reference	Proper Operation
1	Red & White	Pin 1 to Ground	Approximately 0 VDC when ignition is OFF +12 VDC when ignition is ACC or ON
2	Black	Pin 2 to Ground	Approximately 0 VDC

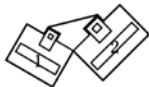
**Connector C3 - Wireless Charger "T" Harness to G22 Male Power Outlet**

Pin	Wire Color	Test Reference	Proper Operation
1	Red & White	Pin 1 to Ground	Approximately 0 VDC when ignition is OFF +12 VDC when ignition is ACC or ON
2	Black	Pin 2 to Ground	Approximately 0 VDC



LIMITED WARRANTY – SOUTHEAST TOYOTA

SOUTHEAST TOYOTA DISTRIBUTORS, LLC (“we,” “our” and “us”) provides the following limited warranty on our accessories, excluding tires, (“Accessories” or “Accessory”) installed on a Toyota. This limited warranty is not provided by and does not bind or provide benefit to the vehicle dealer, the manufacturer, or Toyota Motor Sales, U.S.A., Inc. This limited warranty does not apply to tires; please consult the tire manufacturer and/or its materials accompanying the vehicle for any warranty terms concerning tires. This limited warranty also does not apply to ToyoGuard Exterior Paint Sealant and ToyoGuard Interior Protector; please consult the ToyoGuard Limited Warranty Certificate for the warranty terms concerning those products.

SCOPE OF LIMITED WARRANTY:

A. Protection:

- i. **Accessories Installed by Southeast Toyota Distributors, LLC on a new Toyota vehicle.** We warrant that, for a period of 36 months or 36,000 miles, whichever occurs first, we will repair or replace (includes labor), free of charge, any defect in such an Accessory due to faulty material or workmanship, or, at our option, provide a full refund of the purchase price of the Accessory. The warranty period begins on the vehicle's In-Service Date, which is the first date the new vehicle is either delivered to an ultimate purchaser, leased, or used as a company car or demonstrator. Accessories installed by Southeast Toyota Distributors, LLC are identified on the vehicle's window sticker (Monroney Label).
- ii. **Accessories Installed by a Toyota Dealer on a Toyota vehicle.** We warrant that, for 12 months, regardless of mileage, from the date such an Accessory was installed on the vehicle or the remainder of the Toyota new vehicle warranty, whichever is longer, we will repair or replace (includes labor), free of charge, any defect in the Accessory due to faulty material or workmanship, or, at our option, provide a full refund of the purchase price of the Accessory. For a new vehicle, the warranty period begins on the vehicle's In-Service Date, which is the first date the new vehicle is either delivered to an ultimate purchaser, leased, or used as a company car or demonstrator.
- iii. **Accessories purchased from a Toyota Dealer but not installed by the Toyota Dealer.** We warrant that, for a period of 12 months, regardless of mileage, from the date the accessory was purchased, we will repair or replace (does not include labor), free of charge, any defect in the Accessory due to faulty material or workmanship, or, at our option, provide a full refund of the purchase price of the Accessory.

B. Limitation of Warranty. This limited warranty does not apply to, and we will not repair, replace, or reimburse you for: (1) wheel balancing and wheel alignments, except for one wheel balancing or alignment during the first 12 months or 12,000 miles, whichever occurs first, from the vehicle's In-Service Date, as defined above, (2) abrasions or dents, whatever their cause, and any failure or damage resulting directly or indirectly from accidents, collisions, impacts from foreign objects, fire, theft, larceny, explosion, malicious mischief, vandalism, civil commotion, riots, war, or any other similar causes, (3) any failure or damage resulting directly or indirectly from lightning, windstorms, hail, water, floods, subfreezing temperatures, airborne chemicals, tree sap, dust, salt, and any other environmental conditions or similar causes, (4) any failure or damage caused by: (a) a failure of any part, other than the Accessory, (b) any misuse, abuse, improper towing, negligence or lack of maintenance of the vehicle or Accessory, (c) the alteration, modification or repair of the Accessory by anyone other than persons expressly authorized by us to perform such alteration, modification or repair, or (d) the use of the vehicle for commercial purposes, competitive driving or racing, (5) any failure or damage, if the Accessory has not been installed according to instructions, (6) any failure or damage occurring outside of Canada, the United States of America, its territories or possessions, (7) except to the extent required by the state whose laws govern this limited warranty, any consequential, secondary, or unreasonable costs that may be suffered as a result of the need to repair or replace the Accessory, including without limitation any loss of use of the vehicle, road service, towing, storage charges, inconvenience, loss of wages and/or income, additional expense incurred, loss of transportation, rental car expense, or any derivative damage to persons or things other than the Accessory, including other parts of the vehicle, or (8) liability for damage to property or for injury to or death of any person, arising out of the operation, maintenance or use of your vehicle whether or not related to the covered Accessory.

C. Exclusive Remedy. If there is a valid claim under this limited warranty for a defect due to faulty material or workmanship in the Accessory, we will, at our option, either: (i) repair, (ii) replace or (iii) provide a full refund of the purchase price of the Accessory. We have no other obligations under this limited warranty. Refunds will be made to the vehicle owner. If the vehicle is leased, the refund will be made to the leasing company.

HOW TO MAKE A CLAIM: In the event of a warranty claim, please contact the nearest Toyota dealer to arrange for repairs. The dealership must receive our prior authorization before making repairs covered by this limited warranty. The dealer will contact Southeast Toyota Distributors, LLC at 1-888-851-2722, select option #5 (Warranty Department), then option #4 (Repairs), for instructions on processing a warranty claim, if they are not already familiar with the process. If you have any questions or concerns regarding repairs covered by this limited warranty, please contact our **Customer Assistance Hotline at 1-800-301-6859**.

OUR DISPUTE RESOLUTION PROGRAM: Your satisfaction is our highest priority. In keeping with that focus, in the event that an issue arises related to this Limited Warranty, we invite you to call our Customer Assistance Hotline at 1-800-301-6859 to discuss it. In most cases, we expect that a satisfactory resolution of your issue can be reached through engagement with that Department. If our Customer Loyalty Department is unable to resolve your issue to your satisfaction, we offer a dispute resolution program administered by the National Center for Dispute Settlement (NCDS) (“the Program”). The purpose of the Program is to resolve disputes in an informal setting before an impartial arbitrator. The Program is free of charge to you (although you must bear the cost of any expert witness or attorney you elect to employ). You are required to complete the Program before exercising rights or seeking remedies under the federal Magnuson-Moss Warranty Act, 15 U.S.C. § 2301 et seq. (“the Act”). If you choose to seek remedies that are not created by the Act, you are not required to use the Program before pursuing such remedies – although the Program is still available to you to resolve the dispute. When utilizing the Program, you will need to provide (a) the vehicle identification number of your vehicle, (b) the identity of your selling and servicing dealerships, (c) the mileage on your vehicle at relevant times, (d) the date and nature of any relevant repairs, (e) legible copies of repair orders and other relevant documents, (f) a summary of the unresolved issue and the requested action, and (g) your contact information. In most cases, the dispute resolution process under the Program will be completed within forty (40) days of your submission of your request and will consist of steps such as an initial eligibility determination, an opportunity for you and us to submit information in writing relating to your claim, an oral hearing, and a decision from the arbitrator. A decision will be binding on you only if you choose to accept it. You may submit a request to NCDS by telephone at their toll free number: (877)-276-8848 or in writing at P.O. Box 463196, Mt. Clemens, MI 48046. You may obtain additional information regarding the Program at www.ncdsusa.org. In the event that the NCDS does not exist or no longer handles disputes for us at the time that you seek to submit a request, you may contact our **Customer Assistance Hotline at 1-800-301-6859** to obtain current information about our dispute resolution programs.

GENERAL LIMITATION OF WARRANTY: THIS LIMITED WARRANTY IS IN LIEU OF ALL OTHER EXPRESS WARRANTIES OR LIABILITIES. IN NO EVENT SHALL WE BE LIABLE FOR ANY CONSEQUENTIAL OR INCIDENTAL DAMAGES FOR BREACH OF THIS OR ANY OTHER WARRANTY. SOME STATES DO NOT ALLOW THE EXCLUSIONS OR LIMITATIONS OF INCIDENTAL OR CONSEQUENTIAL DAMAGES, SO THE ABOVE INFORMATION OR EXCLUSION MAY NOT APPLY. NO EXPRESS WARRANTY OF FITNESS OR MERCHANTABILITY IS GRANTED BY THIS LIMITED WARRANTY. THERE ARE NO WARRANTIES WHICH EXTEND BEYOND THOSE DESCRIBED IN THIS DOCUMENT. ANY IMPLIED WARRANTIES, INCLUDING THE IMPLIED WARRANTY OF MERCHANTABILITY OR FITNESS FOR A PARTICULAR PURPOSE, WHICH MAY BE APPLICABLE BY OPERATION OF LAW SHALL BE LIMITED TO THE PERIOD OF THIS WRITTEN LIMITED WARRANTY. SOME STATES DO NOT ALLOW LIMITATIONS ON HOW LONG AN IMPLIED WARRANTY LASTS, SO THE ABOVE LIMITATIONS MAY NOT APPLY. THIS LIMITED WARRANTY PROVIDES SPECIFIC LEGAL RIGHTS, AND THERE MAY BE OTHER RIGHTS WHICH VARY FROM STATE TO STATE. ANY ACTION FOR BREACH OF ANY WARRANTY HEREUNDER, INCLUDING ANY IMPLIED WARRANTY OF MERCHANTABILITY, MUST BE BROUGHT WITHIN A PERIOD NOT EXCEEDING 12 MONTHS AFTER EXPIRATION OF THIS LIMITED WARRANTY. THE REMEDIES SPECIFIED HEREIN AND THOSE SPECIFIED BY APPLICABLE LAW ARE THE ONLY REMEDIES AVAILABLE. WE ASSUME NO OTHER OBLIGATION OR RESPONSIBILITY WITH REGARD TO THE ACCESSORY. WE NEITHER ASSUME, NOR AUTHORIZE ANYONE TO ASSUME FOR US, ANY ADDITIONAL LIABILITY IN CONNECTION HERewith.

GENERAL: This limited warranty describes the complete and exclusive rights that result from the purchase of Accessories. No oral representations or statements may be relied upon. This limited warranty may not be amended or modified, and additional rights may not be granted, unless in a written statement signed by one of our officers. This limited warranty shall be governed by the laws of the state where the vehicle is purchased, excluding laws concerning conflicts of law. We may delegate the performance of our duties and obligations and assign our rights and benefits hereunder. For inquiries regarding this limited warranty, we can be contacted directly at **Customer Assistance Hotline at 1-800-301-6859**, or by mail to: **Southeast Toyota Distributors, LLC, Attention: Customer Loyalty Department, 100 Jim Moran Boulevard, Deerfield Beach, Florida 33442.**