

Application Note

Field Loop Configuration

The Trusted™ Input/Output (I/O) modules are designed to monitor field loops for alarm and field cable fault states. The configuration of field loops differs between modules.

This application note:

- explains the circuits required to allow line monitoring of field wiring.
- describes connection and configuration options for different device types, including system and field powered types, volt-free, current sourcing and sinking and two, three and four wire devices.
- suggests options for isolation and protection.

Issue Record

Issue Number	Date	Modification
1	Feb 07	Initial Issue
2	Aug 07	T8297 connections
3	Dec 07	Circuit options
4	Feb 08	Comments incorporated
5	Jun 08	De-en LM Outputs
6	Sep 08	System cable design
7	Dec 08	Low current loads
8	Feb 10	2,3,4 wire AI,8472 nlthresh
9	Aug 12	Clarifications to DI line monitoring
10	Jun 13	T8403 states 0 and 6 not used
11	Aug 17	Page 22: T8824 Resistor network updated. TOC Updated.

Trusted™

AN-T80004 Field Loop Configuration

Rockwell
Automation

12	Feb 20	Page 32: Clarification on minimum no-load threshold value for T8472. Removed references to T8473
----	--------	---

Table of Contents

Analogue Inputs.....	6
Line monitoring.....	6
T8431 and T8432 Termination Options	6
Current sourcing and sinking, active and passive loops.....	7
Two, three, four wire connections	8
Millivolt inputs.....	10
T8433 Termination Options.....	11
Configuration	14
Threshold online update	15
Overvoltage Faults	16
Voltage signals to Analogue Input Modules	16
Background: Input impedance test	16
Workaround	16
MTEST Diagnostics	16
Digital Inputs	17
Thresholds.....	17
Line Monitoring and Marshalling for Volt-Free Inputs.....	18
T8402 Dual Inputs.....	18
T8403 TMR Inputs	19
T8423 35-120V dc Digital Inputs.....	20
T8424 120V ac Digital Input.....	21
Non volt-free digital inputs.....	22
Current controlled inputs.....	22
Field powered inputs.....	23
Hall Effect and Open Collector/Open Drain	24
Zone Interface and Valve Monitor Inputs.....	25
Termination Options.....	25
Diagnostic Test Termination	25
Configuration	26
Frequency/Pulse Inputs.....	27
Digital Outputs	28
Power Groups	28
Line Monitoring.....	29
No field supply voltage (state 1).....	29
Output de-energised/off (state 2).....	29
Open circuit in field wiring or load (state 3).....	29
Output energised/on (state 4)	30

AN-T80004 Field Loop Configuration

Short circuit in field wiring or load (state 5)	30
Field fault (state 6)	30
Channel fault (state 7+).....	30
No-load (Open Circuit) Threshold	31
Triplicated Modules 8448, 8449, 8451, 8461, 8471	31
Quad Structure Modules 8472	32
Termination	33
T8842 VFTA.....	33
T8850 and T8870 FTAs	34
Power Termination.....	35
T8472 Termination.....	35
Terminating Resistors.....	36
Volt-free outputs.....	36
Hazardous area outputs.....	37
Device Characteristics.....	37
Low current loads.....	37
Dynamic loads.....	37
High inrush current loads	38
Power supply fluctuations	38
Analogue Outputs	39
Module circuit	39
Line Monitoring.....	39
No field supply voltage (state 1).....	39
Output de-energised (state 2)	39
Open circuit in field wiring or load (state 3).....	39
Output energised (state 4)	40
Current demand cannot be met (state 6).....	40
Channel fault (state 7).....	40
Termination	40
Hazardous area outputs.....	40
Pulse Outputs	41
Other Issues	44
System Cable Design.....	44
Analogue or Digital Input module to FTA.....	44
Analogue or Digital Input module to VFTA.....	45
Digital Output module to FTA, Standard Cable.....	46
Digital Output module to FTA, integral power cable	47
Digital Output module to VFTA	48
Analogue Outputs	49

AN-T80004 Field Loop Configuration

Floating Earth Systems and Loop Isolation.....	50
Hazardous Area Protection	50
System installation	50
EEx certification	50
Non-incendive certification.....	50
Lightning Protection.....	50
HART interfacing	51
Cable earth and screen wires.....	52
Free Wire Cables	53

Analogue Inputs

Line monitoring

Field loops providing analogue input signals to a Trusted™ system do not require line monitoring components to be fitted to the field device, because the measured current acts as the proof of the presence of the line. However, analogue inputs should be checked for accuracy periodically because partial shorts will offset the measurement.

T8431 and T8432 Termination Options

The T8431 and T8432 Trusted™ Analogue Input modules are designed to monitor input signals in the range 0-6V (0 to 22mA via a 250R resistor). The input zero volt reference wires are linked together across the module, so although there is isolation between field and system, there is no isolation between channels. The T8431 has 40 triplicated input circuits and the T8432 has 60 dual input circuits.

Field termination assemblies are available to provide field terminations for most applications.

The T8830 allows connection of system powered two wire devices to a T8431. It requires an FTA cable, TC-201, 203, 501 or 503, to connect to its cable socket. It does not provide a zero volt reference to field devices, so it is only able to directly connect to system powered devices.

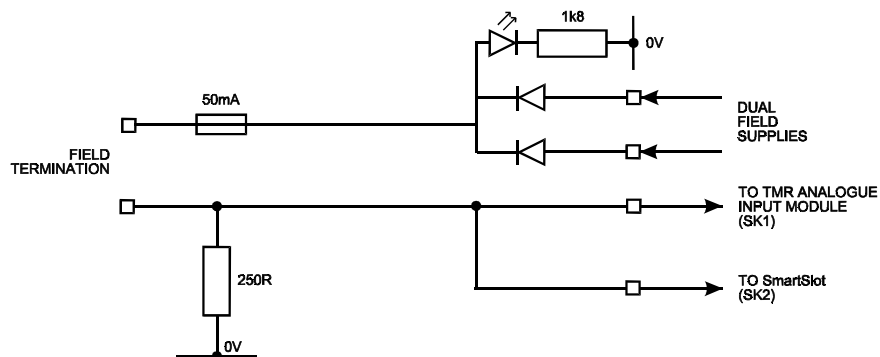

The T8831 is similar but replaces the fuse with a resistor, limiting available power for non-incendive applications (non-incendive hazardous area specifications specify limited loop power and are used in the Americas).

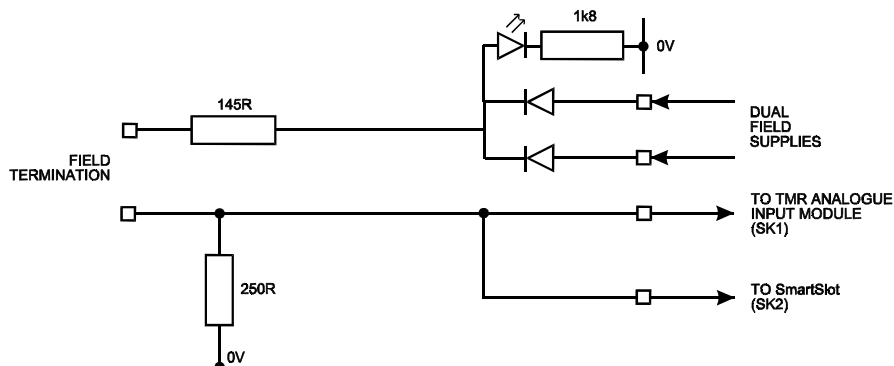

AN-T80004 Field Loop Configuration

The T8842 Versatile Field Termination Assembly (VFTA) provides individually configurable channel circuits for a T8431 and other low voltage 40 channel modules. It also provides three-wire connection (24V supply, signal and zero volt reference). It requires a VFTA cable TC-211, 212, 511 or 512. Circuit configuration is given in PD-8842. Fuse ratings may be chosen up to a total of 3A per group of eight channels. For analogue inputs, a link is required in position E, a 50mA fuse in position A to limit the current loop, and a 315mA fuse in position B. If the device requires more power, fit separate fused terminals alongside the VFTA.

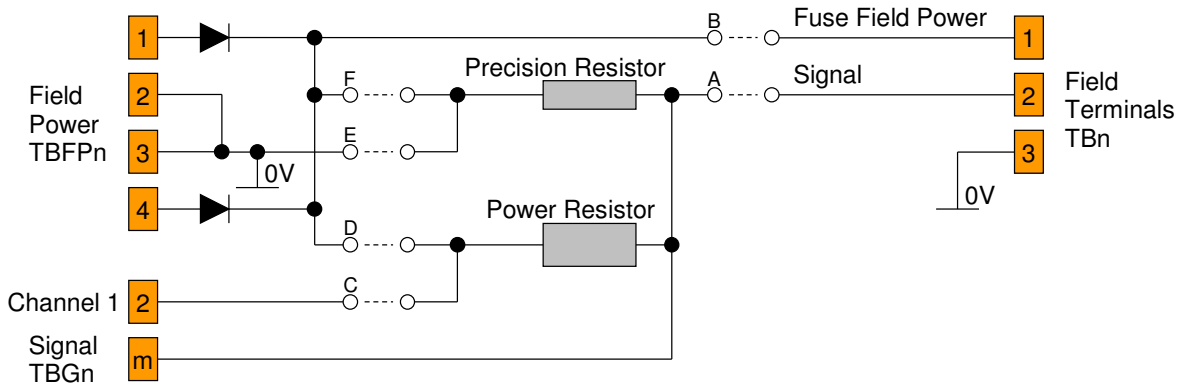

Four-wire devices also require a power 0V return as well as a signal reference. For power less than 315mA, fit both zero volt wires to terminal 3. If separate fuse terminals are required, also fit separate zero volt terminals.

Other VFTAs have existed but were all fixed versions of the T8842.

Current sourcing and sinking, active and passive loops

The T8431 and T8432 all expect to measure the voltage on the channel with respect to the zero volt reference. In the current loop circuits above, current flows into the system circuit, down through a precision resistor (thus creating a voltage drop), and into the zero volt reference. The input channel voltage above the zero volt reference is therefore a measure of the loop current.

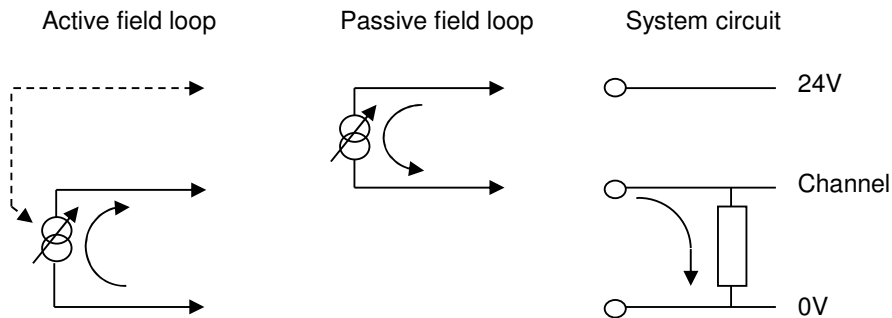

In the diagram above, an active or field powered loop drives current round the loop. It may have its own local power supply, or be powered from the system through VFTA or separate terminals.

A passive or system powered loop takes a little power from the system supply to drive a variable loop resistance which controls the loop current. This is the reason that current loops are usually 4 to 20mA; the spare 4mA is used to power the resistance control.

All these devices are current sourcing, that is, they supply current to the system's channel connection. Some devices are current sinking; they take current from the channel connection. These devices cannot be directly connected to T8431 or T8432 inputs, because the system circuit would have to measure voltage from the supply rail with an upside-down circuit, as shown below. This circuit cannot be used.

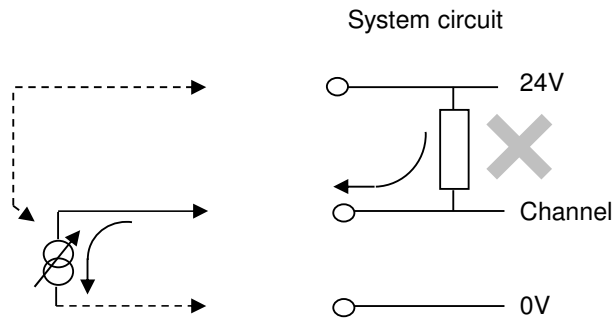

This circuit cannot be used.

Usually the current loop is not even returned to the system but is added to the field device's own power zero volt reference. Therefore the only available measurement point for the current is the channel connection. The T8431 and T8432 are not designed to measure voltage with respect to the supply rail, and so the circuit above is not possible. The solution is to fit a current isolator device (e.g. MTL5040) which makes it possible to reflect the current in the opposite direction, allowing it to be fed into the channel connection.

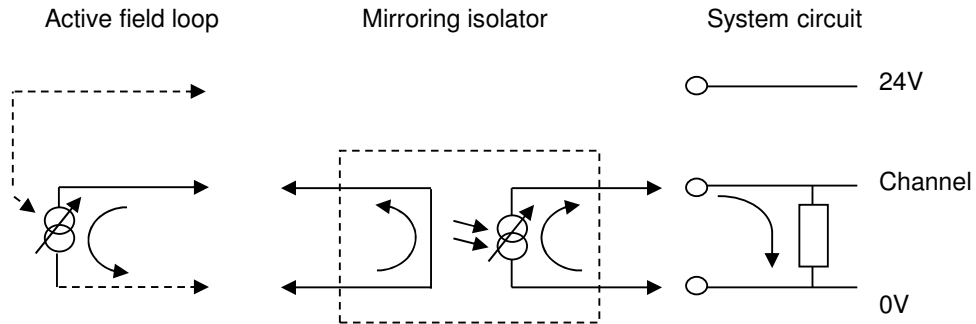

Two, three, four wire connections

The passive field loop shown on the previous page is a two wire device; the 4-20mA loop current is regulated by the device, and flows out on one wire and back on the other. An FTA is adequate for this circuit, and the 50mA fuse protects the input against shorts.

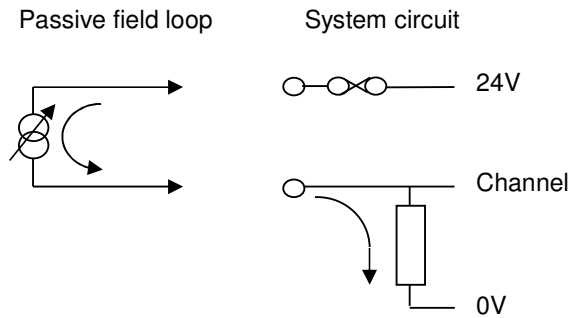

The current loop allows 4mA to drive the device electronics. However, most field devices need higher power. This must be provided with a separate power connection. This is now a three wire device. Note that the fuses on the FTA should not be replaced with higher rating fuses because a short between the fuse and the channel input may damage the channel. VFTAs include a zero volt terminal, but if FTAs are used, fit a separate zero volt terminal.

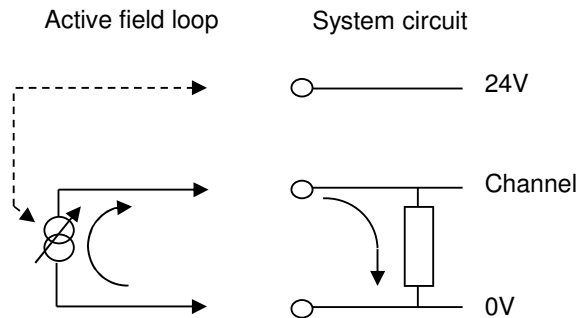

Some devices have another connection. These have separate zero volt power and current loop return connections, allowing the current loop to be isolated. For 8000 series analogue inputs, wire the two connections together.

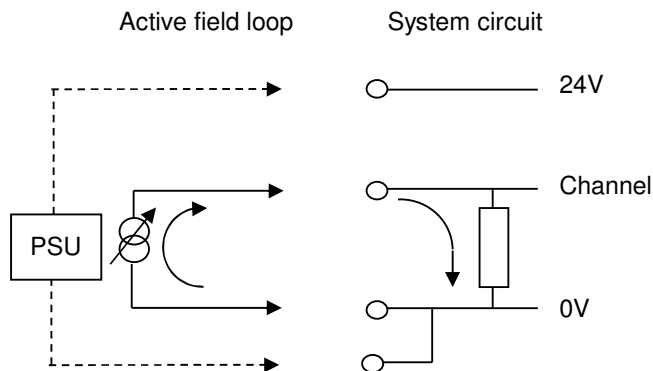

Millivolt inputs

The T8840 allows a block of eight channels of a T8431 to be connected to thermocouple, RTD or other millivolt inputs using plug-in converters. It requires a VFTA cable TC-211, 212, 511 or 512, which provides separate plugs for each group of channels. This can be wired via a VFTA T8842 allowing some channels of the module to be used for current loops. Configuration options are given in PD-8840.

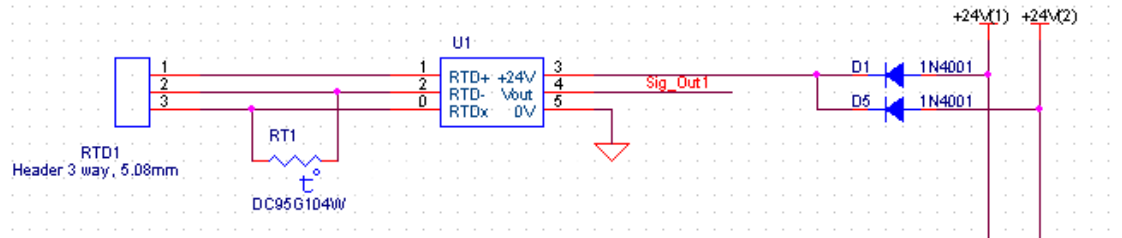

The T8841 is similar to the T8840 but is specially designed for RTD inputs.

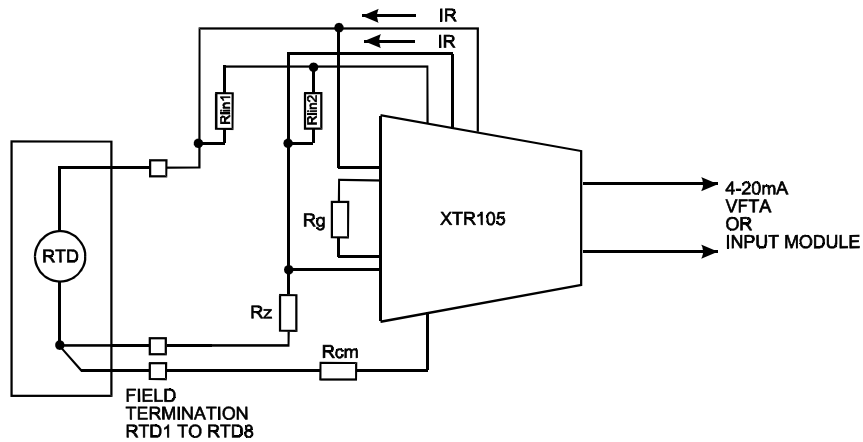

T8433 Termination Options

The T8433 Trusted™ Isolated Analogue Input module has individually isolated inputs. These measure 0-22mA. The module has a three-wire connection for supply, reference and signal; the extra wires mean that there is only room for 20 channels. The module input circuit is completely isolated and requires an external supply of 4.5 to 8 volts, derived in the circuit below from the loop.

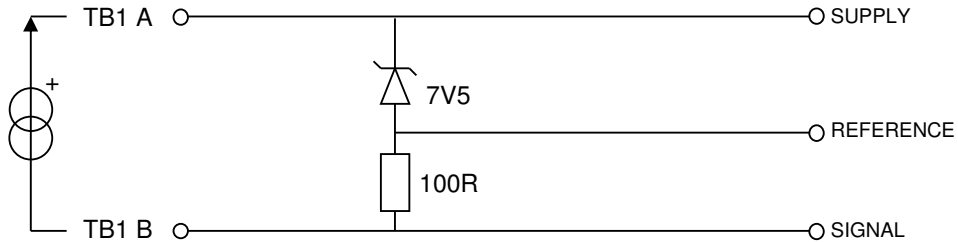

The diagram above shows the input circuit using a T8833 FTA, a T8433 isolated analogue input module and a 60 channel cable TC-601, 603, 701 or 703. 60 channel cables are required due to the extra wires needed.

The current loop is measured across the 100R resistor (creating a voltage drop of 0.4 to 2 volts for 4 to 20mA). However, the isolated input circuit also needs a power source of between 4.5 and 8 volts; in the above circuit it is provided by the zener diode using the current in the loop from the transmitter. All circuit permutations need to allow for current measurement and channel power on opposite sides of the common reference wire.

The T8433 FTA above allows for field powered current sourcing inputs, i.e. from devices that have their own power supply and drive the current loop towards the channel. The device needs to have at least 7.5 volts of spare loop drive available.

If the device is passive, i.e. it controls the current flow through itself but does not supply power to the loop, it can be powered from an individual isolated supply as shown below.

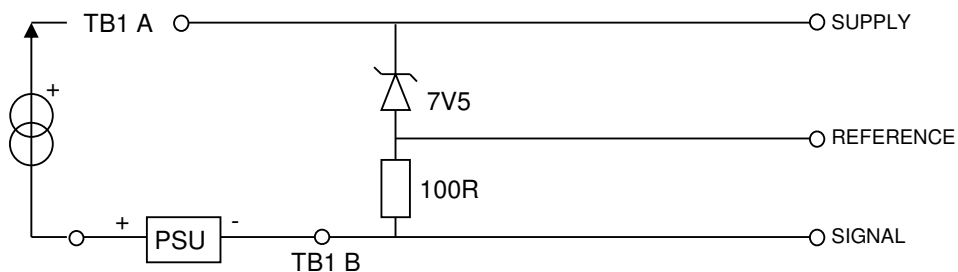

This clearly requires an extra stage of terminals between the FTA and the field. Note that although it is possible to use one power supply to power several loops, they would then no longer be isolated from each other.

AN-T80004 Field Loop Configuration

The T8834 FTA is a configurable version of the T8433. This also connects to I/O cables TC-601, 603, 701 or 703. It also contains a zener diode for the channel power and a precision resistor for the current

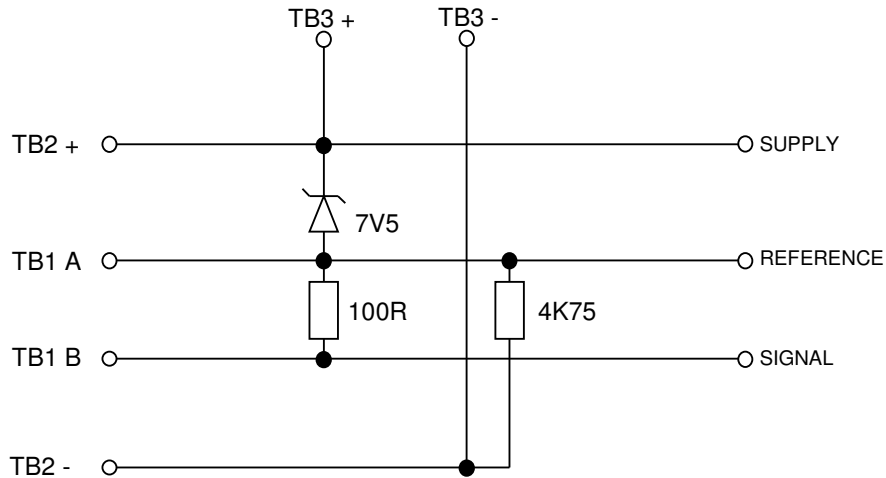

to voltage conversion, but it may be wired in several different ways.

For field powered (active) devices, sourcing current to the channel, where the channel current does not go below 4mA:

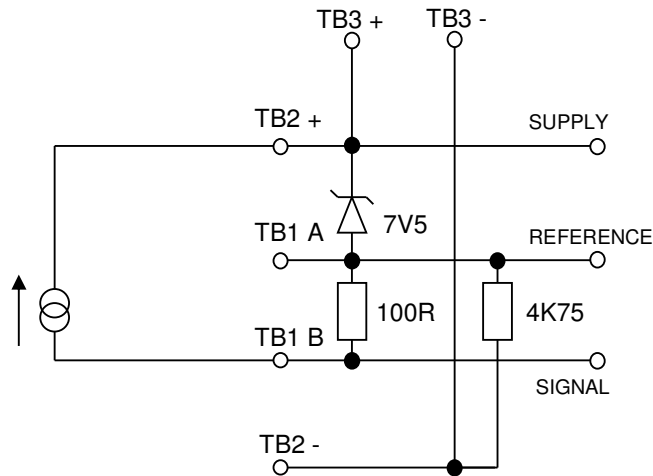

AN-T80004 Field Loop Configuration

For field powered devices, sourcing current, where the channel current could go below 4mA (e.g. gas detector optics alarms):

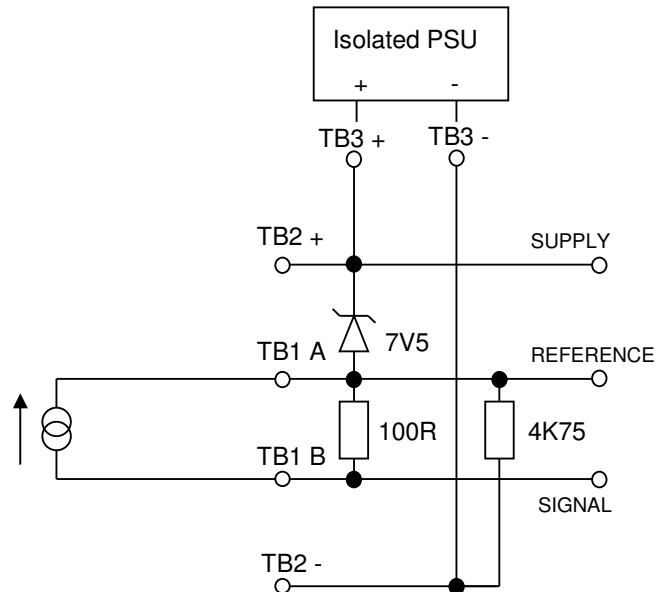

Since the current loop is on the negative side of the channel power, it is possible to configure the T8834 FTA to power and sense current-sinking devices, where the loop draws current away from the channel. Current sinking devices need a separate power supply.

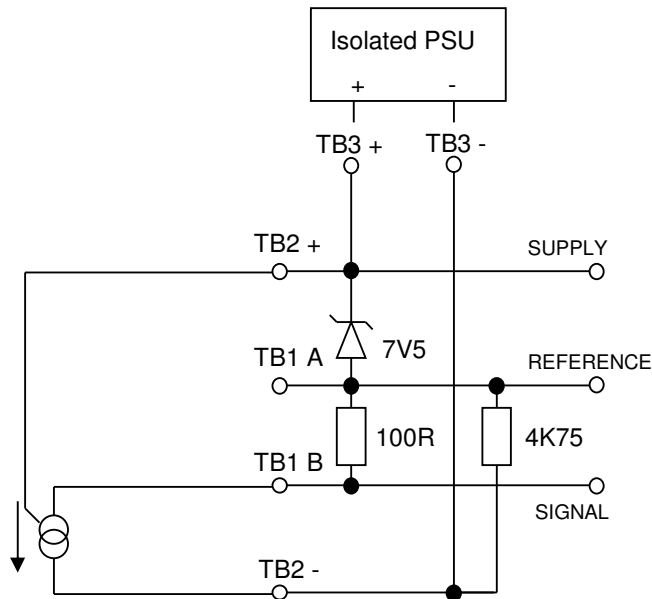

Product description PD-T8834 shows the full circuit diagram of a channel. The circuit includes links which could be modified to accommodate other requirements.

Configuration

There are seven input voltage state thresholds detected by all of the analogue input modules, numbered 0 to 6. States 0 and 6 are 'out of range' indications, outside of the normal operating range. The remaining five are configurable using the System Configuration Manager. The voltage transition between each state can be split into a rising transition and a falling transition. In the diagram below, the input goes from state 4 to state 5 as it rises above 2.28V. It returns to state 4 as it falls below 2.24V. There are four configurable pairs of state transitions, numbered T1 to T8 below. These are configured using a threshold template as described in product description PD-8082.

Typical voltage threshold values		Input Channel State	Line Fault Status		
		Over-range	6	True	
Tmax	6.0	High-High	5	False	
T8	2.28		4 or 5		
T7	2.24	High	4		
T6	1.82		3 or 4		
T5	1.79	Normal	3		
T4	1.52		2 or 3		
T3	1.47	Low	2		
T2	1.12		1 or 2		False / True
T1	1.11	Low-Low	1		True
Tmin	-0.5V	Under-range	0		True

The input states can be used to define alarm trips, detector conditions, near-overrange signals, valve positions on analogue position sensors etc. There is room to define states for input conditions like gas detector dirty optics as well as alarm thresholds. Note that state 1 indicates a line fault.

The system configuration for I/O modules can only be loaded when the system is shut down and restarted. This includes threshold changes. However, there is an online method for entering a new set of thresholds using the THRSHIN and THRSHOUT boards which is described below. Alternatively the analogue reading may be converted in the application using comparative logic.

Threshold online update

The channel thresholds can be read or written using the THRSHOUT and THRSHIN boards in the I/O connection table, through the Toolset Debugger's online view. The thresholds are shown in raw units, at the same scaling as the AI board (0 = 4mA or 1V, 4096 = 20mA or 5V).

To read a channel's thresholds, enter the channel number on THRSHOUT channel 3, then change THRSHOUT channel 2 from 0 to 1. The thresholds will appear on the THRSHIN board. In the example below, the thresholds for channel 10 have been requested.

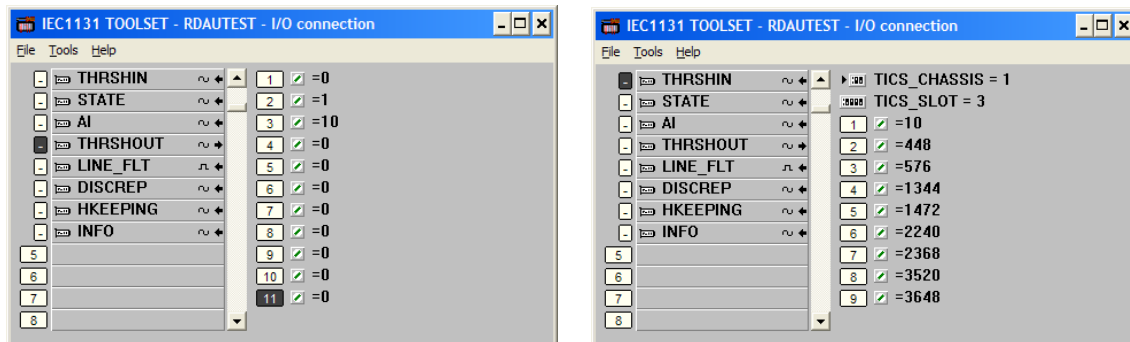

To write new thresholds to a channel, enter the new thresholds on channels 4 to 11 of THRSHOUT. Enter the channel number on channel 3 of THRSHOUT, then change THRSHOUT channel 1 from 0 to 1. In the example below left, new thresholds for channel 13 are been loaded. On also setting channel 2 to 1, the thresholds are confirmed on the THRSHIN board on the right.

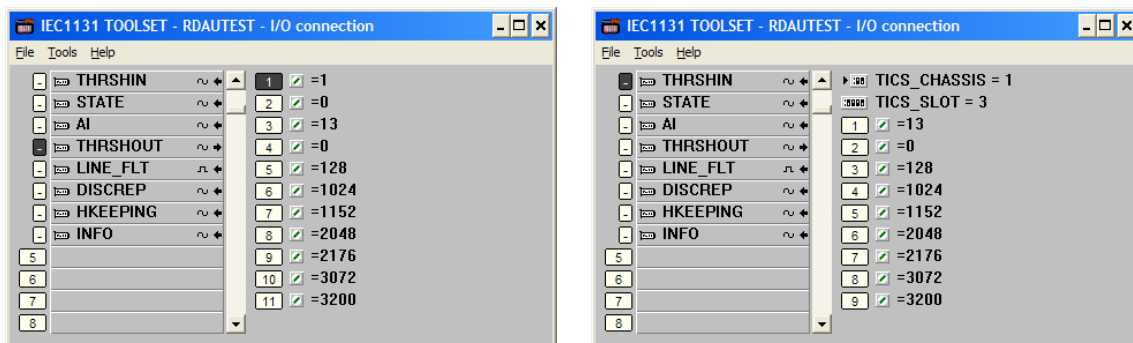

The manual processes described above could also be automated through the application.

Having changed the thresholds online, remember to update the system INI configuration template and load it into the system. This will ensure that the changes are loaded on the next black start. The online changes are not saved in the processor's copy of the INI file.

Overvoltage Faults

The analogue inputs are not designed to measure voltages up to 24V. The A/D conversion will reach its maximum at about 7 volts. Above this point, the measurement parameters will be at the maximum values. This causes module channel faults (0x52nn) to be reported, which appear as slice faults.

Voltage signals to Analogue Input Modules

This section describes the issues involved with the connection of voltage signals to T8431 analogue input modules without the use of a 250 ohm burden resistor, usually used to convert current loops to voltage signals.

Background: Input impedance test

Current loop analogue signals are wired to a 250 ohm burden resistor to convert 0-20mA to 0-5V (as an example). The input circuits are biased internally to 2.5V. An input impedance test is run periodically inside the module. This test adds a disturbance signal to the input circuit which is later filtered out before the measurement is delivered to the processor. The test measures the effect of the disturbance and calculates the impedance of the input circuit. The 250 ohm burden resistor is factored out of the calculation, to leave the true impedance of the line. Out of range (short circuit or open circuit) impedances are recorded. If an out-of-range impedance appears on several subsequent tests on at least two input circuit slices, then a fault state is declared on the channel.

With a voltage input which has very low or high impedance, the above test will declare a fault after confirmation and voting, which can take a few minutes. The result is that the input state number is set to the fault state and the input measurement is set to -2048 as the failsafe value.

Workaround

The recommended method to enable the use of voltage inputs is to fit a 250 ohm resistor. The value is nominal in this case (e.g. 200-300 ohms) and simply biases the impedance into the accepted test range. For low impedance inputs, the resistor should be wired in series to add impedance to the line. For high impedance inputs, the resistor should be wired in parallel as in a current loop circuit. In both cases, the impedance test should be able to detect line faults.

Correcting the input impedance will also improve the input measurement accuracy at the high and low ends of scale. An offset will be observed at the ends of the range if the input impedance differs significantly from 250 ohms.

MTEST Diagnostics

Applications have been reported that inhibit the module diagnostic tests by loading an 'Additional CLI' template with 'MTEST=OFF'. This is not a recommended workaround. This command will turn off other diagnostic functions in the module in addition to the impedance test. It is not stored as part of the INI configuration in the module. This means that although it will be downloaded from the processor on startup or on offline insertion of a module (where the active module is removed and a new module is inserted), it is not transferred on a hot swap to a module in the secondary module position. Therefore if a hot swap is performed to the secondary position, and the secondary module is left in operation, the impedance test will shut down the inputs after a few minutes.

In these applications, it is necessary to swap back to the primary slot before the diagnostics have run, or to remove and reinsert the module in the primary position. Both of these actions will reload the INI from the processor in full. Removal and reinsertion requires redundancy logic in the application to avoid loss of signal.

Digital Inputs

Thresholds

Digital inputs are essentially analogue inputs which are interpreted as digital. The voltage on the input circuit is measured and allocated to an input state using thresholds, similar to analogue inputs above. For digital inputs, the state bands are essential, since they define the digital input 'off/open' and 'on/closed' as well as line fault status. The thresholds are similar to analogue inputs except that they operate over a wider voltage range. There are five configurable states separated by pairs of thresholds for rising and falling state change. There are no THRSHIN and THRSHOUT boards to change the thresholds online.

Typical voltage threshold values		Input Channel State	DI Status	Line Fault Status
	Over-range	7	False	True
Tmax 36.00	Short Circuit (approx 24V)	5	False	True
T8 22.00		4 or 5	False / True	False / True
T7 21.00	Contact Closed (approx 16V)	4	True	False
T6 12.75		3 or 4	False / True	False / True
T5 12.25	Contact Indeterminate	3	False	True
T4 11.75		2 or 3		False / True
T3 11.25	Contact Open (approx 8V)	2	False	False
T2 3.00		1 or 2		False / True
T1 2.00	Open Circuit (approx 0V)	1	False	True
Tmin -8.00	Under-range	7	False	True

Thresholds are defined using a threshold template in the system configuration. Product description PD-8082 describes how to edit threshold templates. The example above shows 'Closed' defined at nominally 16 volts and 'Open' at nominally 8 volts, for a 24V digital input module. These are spaced equally through the input voltage range, which allows broad voltage bands for each state.

Line Monitoring and Marshalling for Volt-Free Inputs

Field loops providing digital input signals to a Trusted™ system need line monitoring components if they are safety related inputs or require assurance of operation.

Defining the open and closed states nominally at 16 and 8 volts (as above) simplifies the selection of line monitoring components.

There are two types of 24V dc digital input module; T8402 (dual) and T8403 (TMR). These use different field termination assemblies, which affects the selection of line monitoring components.

Using both the circuits shown below, an open switch on a healthy line will signal 8V to the module, and a closed switch will signal 16V. Thresholds between each state should be placed to allow at least 2 volts error, an indeterminate state between open and closed, detection of open and short circuit and a gap between each of the rising and falling thresholds to prevent rapid cycling between states.

Other configurations may be used, but the thresholds should be set around the expected voltage levels in each state.

T8402 Dual Inputs

The diagram below shows the recommended configuration of a volt-free contact field loop monitored by a Trusted™ Dual 24V dc Digital Input Module T8402, connected through a T8802 FTA. This requires a 60 channel cable, TC-601, 603, 701 or 703. The T8402 has two input circuits for each of the sixty channels.

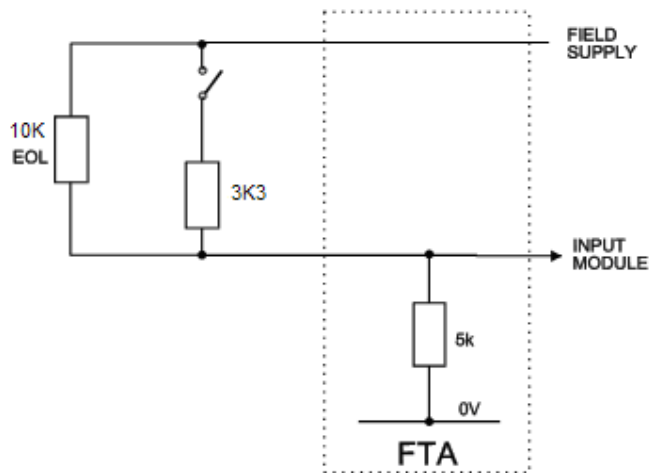

Field devices forming inputs to T8402 input modules may be conditioned using resistors. This is because the equivalent input impedance is located on the Field Termination Assembly (FTA), therefore when the input modules are paired in a hot swap arrangement, the effective impedance seen by the field loop remains unchanged.

It is also possible to use the zener circuit shown below with T8402 module inputs using a T8802 FTA.

If free wire cables (TC-602, 604, 702, 704) are used to wire to terminals, the resistor must be wired in the terminals. 5K is a nominal value and the more standard 4K7 could be used.

T8403 TMR Inputs

When using the Trusted™ TMR 24V dc Digital Input Module T8403 with volt-free contact field devices, it is better to clamp the voltages rather than rely on potential dividers, because the loop termination resistor is inside the module and will be paralleled with another during swapping, changing the resistance.

The field loop configuration shown in the diagram below is recommended for T8403 (and is also acceptable for T8402). The FTAs used for T8403 inputs do not have resistors fitted, but the modules themselves have resistors. The T8403 has three input circuits for each of the forty channels.

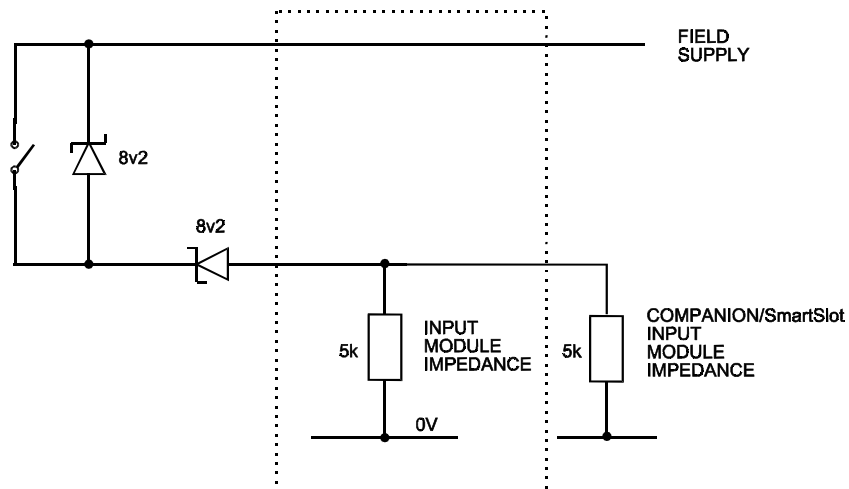

Two Zener diodes are necessary to clamp the voltage at pre-determined levels when a second module is fitted in the adjacent Companion slot or the SmartSlot position. The Zener diodes may also be 7V5; the difference is insignificant. The 8V2 diodes will dissipate 27mW on a closed switch with two modules, but should be rated for at least 410mW with a T8800 FTA, which is the power expected on a short circuit to zero volts due to the T8800 fuse rating of 50mA.

Resistors may also be used for line monitoring with T8403 modules, but the effect of the parallel 5K module impedance (above) and variations in power supply must be taken into account when choosing resistor values and thresholds. The resistors shown for the T8402 on the previous page are a good starting point.

The T8800 has 50mA fused supplies to each channel.

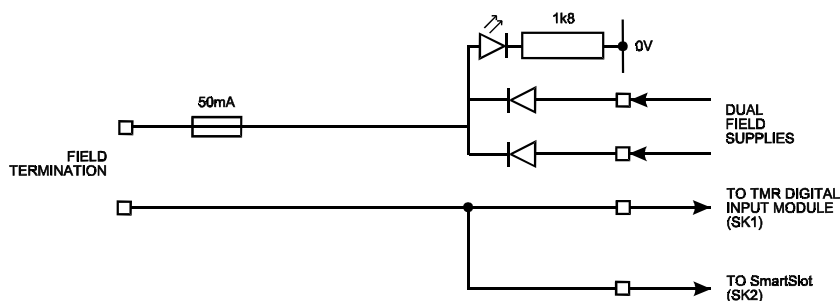

AN-T80004 Field Loop Configuration

For systems conforming to AANSI/ISA non-incendive hazardous area specifications, the T8801 replaces the fuses with resistors to limit the available power. In this case, the field zener diodes will only dissipate 100mW on a full short circuit to zero volts.

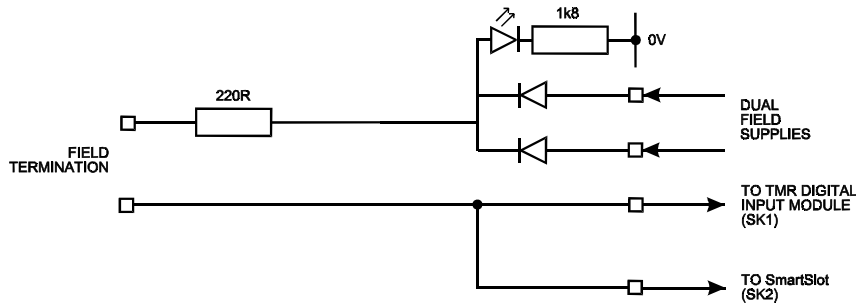

T8423 35-120V dc Digital Inputs

The T8423 is similar to the T8403, but is rated for any supply voltage from the upper range of the T8403 up to 140 volts dc maximum. It has an internal impedance to earth of 60Kohm, so when two modules are paired, the impedance will drop to 30Kohm. Therefore, volt-free contact inputs should use zener diodes, which should be specified at approximately one third of the supply voltage. The thresholds should then be positioned around open and closed voltages of two-thirds and one-third of the supply voltage, as for 24Vdc inputs.

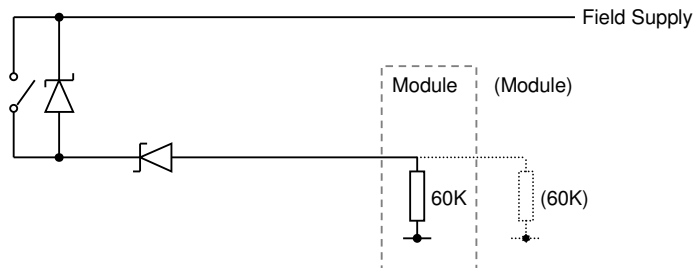

It can be used with the T8821 FTA, which has neon power supply indicators designed for 120V dc. This requires I/O cables TC-201, 203, 501 or 503.

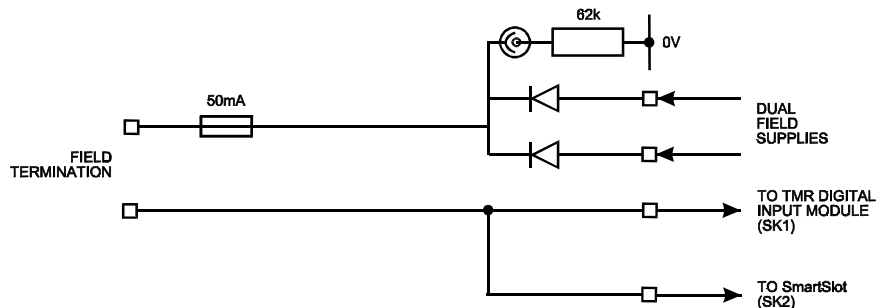

The T8423 can also be terminated at fused terminals (providing the same functions as T8821), using I/O cables TC-202, 204, 502 or 504.

T8424 120V ac Digital Input

The T8424 is actually a T8431 analogue input module with different firmware (and labels). It has to be used with a T8824 FTA and TC-211, 212, 511 or 512 I/O cables.

The T8824 FTA contains resistors that divide the voltage down to analogue input levels. If any resistor goes open circuit, the overall change in value will not change the input state. In the diagram below, the field switch is assumed to be volt-free and the field AC input is the 120V ac power supply.

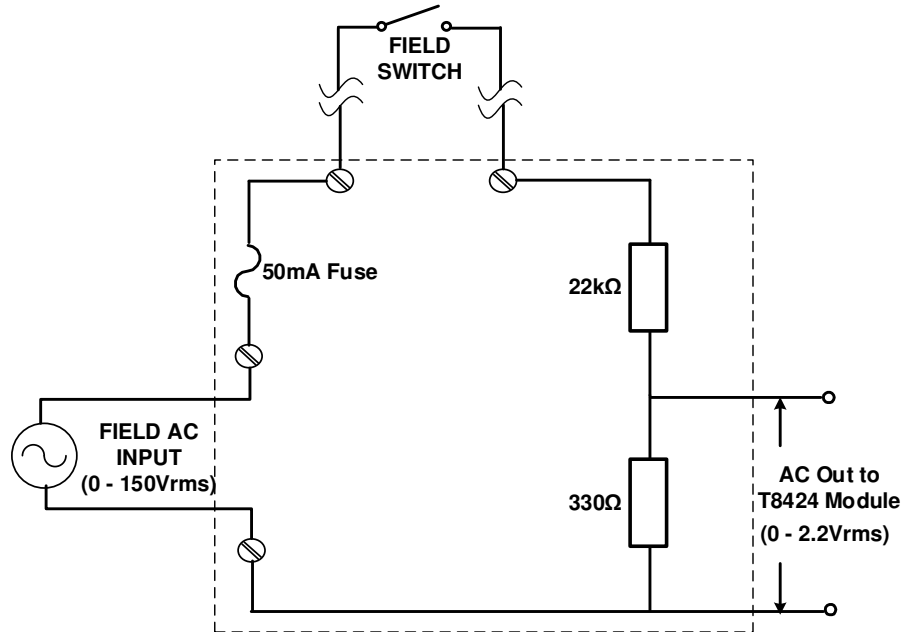

The T8424 does not recognize a threshold template; if one is downloaded it will be ignored. It has fixed state change (hysteresis) voltages. Voltages below 26V ac are reported as 'off' (state 2) and voltages above 82V ac are reported as 'on' (state 4) with the last reported state held between these voltages. The module can measure up to 150V ac.

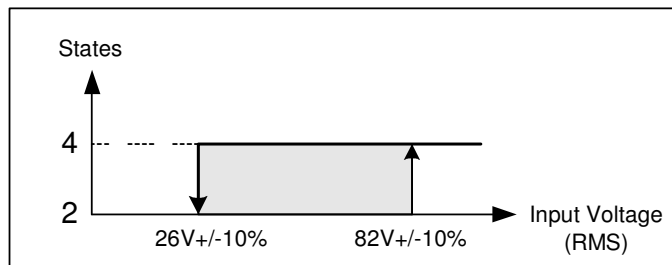

Non volt-free digital inputs

The information above is for isolated volt-free contacts, which are the simplest kind of digital input. The system is able to apply its own voltage and measure the effect without any external influences apart from the switch state. However, the input device or system must isolate the contact, e.g. using a relay or solid state switch.

This section describes approaches for interfacing to digital inputs which are not isolated or not volt-free simple contacts.

Current controlled inputs

This covers all inputs where the loop current (as opposed to the voltage) is used as an indication of input state. One example is proximity sensors to Namur EN60947-5-6. These devices pass about 0.5 to 1mA for 'off' (proximity detected) and about 2 to 6mA for 'on' (proximity absent). They also need a low voltage supply, e.g. 8V. This limits the available detection range for a digital input module.

The answer is to use an interposing barrier, e.g. MTL 4113P or MTL5018ac, which supplies the appropriate voltage and detects the loop current. These will also provide contacts for open/short circuit detection, allowing monitoring of the field loop. They inherently provide intrinsic safety isolation.

Where hazardous area certification is not required, it may be possible to treat the device as an analogue input, wired to an analogue input module. Since the system's 250R resistor will drop some voltage, the supply to the device should be set near the top of its range.

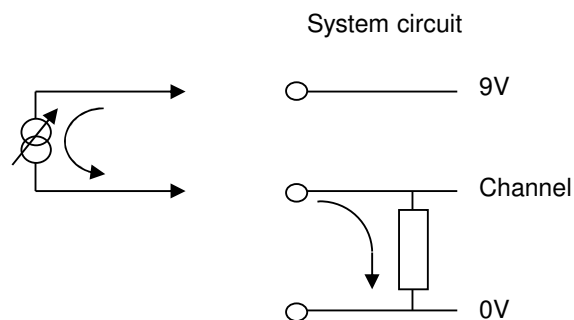

The input may now be treated as a 0 to 20mA loop, and thresholds can be set as described earlier in this document according to the device specification. For Namur proximity sensors, a common specification is:

Open circuit	<0.28mA	<0.07V (with 250R resistor)
Proximity detected	0.35 to 1.2mA	0.09 to 0.3V
Proximity not detected	2.1 to 6mA	0.53 to 1.5V
Short circuit	>6.5mA	>1.63V

These ranges can be converted to input states using a threshold template, with thresholds set between the current values shown above.

Field powered inputs

These inputs appear as a voltage signal, powered by the remote device. This is likely to be another PLC, which may or may not have isolated outputs.

There is an inherent danger with field powered inputs: the system supplies may be on different mains phases, causing damaging potential differences, unsafe wiring, or even just massive signal noise on semi-isolated channels. All field powered inputs must therefore be isolated. In the three circuits shown below, note that each has a point of isolation.

All Trusted digital input modules provide isolation between the system and field voltages, but they do not provide isolation between individual channels. Therefore an input module can be assigned to receive all inputs from another unisolated PLC, as long as there are no other devices connected, or all other devices are isolated. However, the input wiring must be physically protected as if it is mains wiring, because it may be at a high potential with respect to the system.

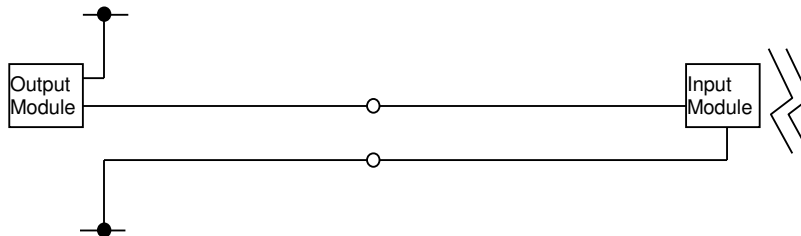

If a whole input module cannot be assigned to just one remote system, care must be taken to ensure that isolation is provided between each supply source. This may include isolated outputs at the remote end to Trusted:

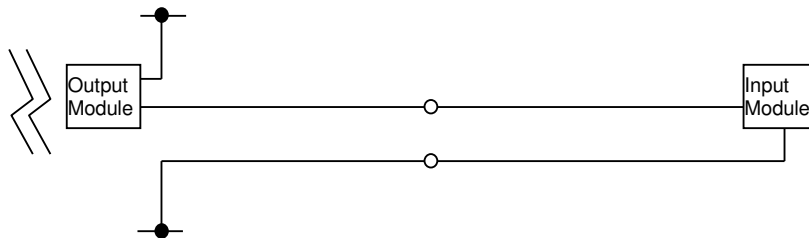

Or relay/galvanic/optical isolation devices in the loop:

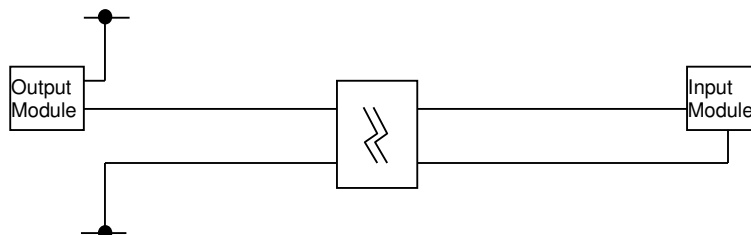

For relay isolation, safety related signals should use appropriate certified safety relays. These are described in the digital outputs section.

The isolation device should be placed near the remote end, so that the digital input module can monitor the line for short/open circuits. Line monitoring components may be required to set the measured voltages for 'open' and 'closed' states. If the remote device is also a safety system, it should be set to monitor its side of the circuit (and an auxiliary contact if using a safety relay).

Hall Effect and Open Collector/Open Drain

These devices are all essentially semiconductor switches in different configurations.

A Hall Effect sensor is a simple proximity detector, using a semiconductor. When magnetic material is nearby, the semiconductor will conduct like a diode (one way). When the device is away from magnetic material, it stops conducting. It may be imagined as a transistor without a base connection. This device has a semiconductor voltage drop when conducting (about 0.6V). It may be treated as a volt-free contact and monitored with two 8 volt (7V5, 8V2 etc.) zener diodes as shown below.

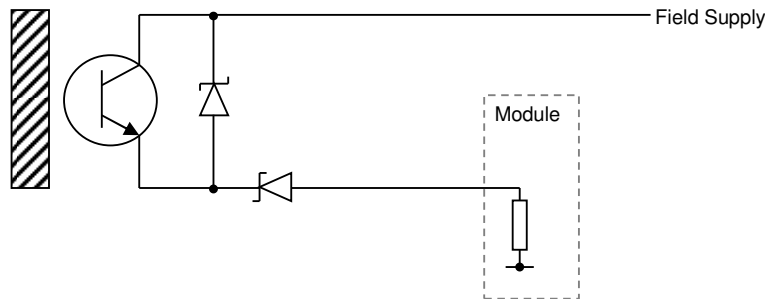

Open collector outputs also act as volt-free contacts but are wired on the collector side. Since these by definition are not isolated or protected, they should only be used when the input module and open collector output may be referenced together on the same local cabinet supply. Open collector outputs are often present on older electronic logic devices. Open drain outputs are the equivalent for FET devices. These outputs will draw significant current when they are switched low/off, but are essentially open circuit when switched high. They therefore need an external pull-up resistor.

A suggested circuit is shown below.

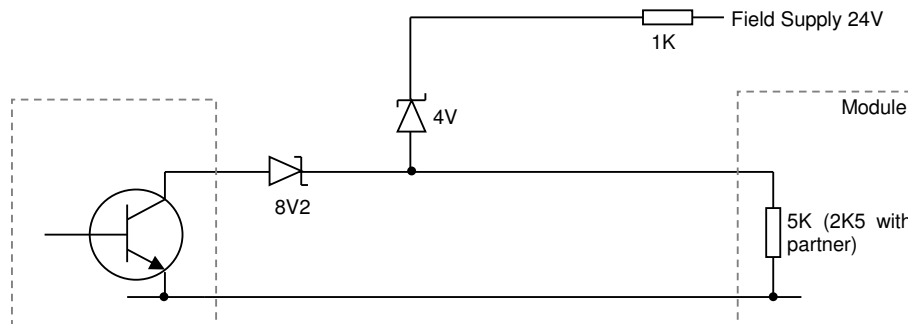

When the output is high, it is open circuit. The current path is therefore through the 1K resistor, 4V zener and the module's internal impedance (shown here for an 8403). The voltage at the digital input will be about 15 to 17 volts, depending on whether the module has a partner fitted.

When the output is low, it will conduct. The voltage at the input will drop to 8.2 volts plus the semiconductor diode voltage drop.

The circuit requires the zero volt returns to be joined between systems, and so this should not be used to connect distant systems. If the zener diodes are fitted near the output end, all line faults can be detected except an open circuit on the zero volt link which will appear as a high output.

Zone Interface and Valve Monitor Inputs

The T8448 and T8449 modules have the same hardware as the T8451 digital output module, but with different firmware fitted to change their operation. The T8448 Zone Interface Module may have its channels individually configured as inputs or outputs and is intended to provide all the I/O needed for a single fire zone. The T8449 Valve Monitor Module has a fixed alternating pattern of inputs and outputs and is intended for driving safety valves with added testing and monitoring through the inputs.

The inputs on these modules use the monitoring circuits normally used to report the actual state of each output. These have a limited accuracy of 1/8th of a volt and so are not suitable for any analogue inputs except from fire or gas detectors. This accuracy is quite adequate for 24V dc digital inputs.

Termination Options

Both of these modules need to be used with the Versatile Field Termination Assembly (VFTA) T8842. They therefore need a 40-channel output module VFTA cable TC-209, 210, 509 or 510. The T8842 is configured using plug-in links and components to allow the use of different field devices. Product description PD-T8842 describes how to configure the VFTA for:

- Fire detector inputs, needing significant power
- Digital inputs from line monitored volt free contacts
- Powered digital outputs
- Current loop analogue inputs
- Inputs from detectors which are reset by removing power
- Valve position switches to convert to a stepped analogue input

The T8842 can connect to three wire devices and supply up to 315mA per channel. If more power is required (e.g. for beam gas detectors) or separate power is required (e.g. for the beam transmitter), fit a separate fused terminal for each device.

Diagnostic Test Termination

These two modules perform a test on input channels to determine if the input will sense a closed contact. To do this, the channel's output circuits are energised briefly and the input is monitored for a voltage rise. If the input is wired to a closed non-line monitored volt-free contact (thus shorted to zero volts) or to a zener diode circuit (thus clamped to a voltage), the voltage will not be able to rise far enough to satisfy the test and a slice fault will be reported.

To allow the test to run with shorted or clamped inputs, an impedance is needed on the line to allow the voltage monitored on the module to rise above a threshold. Therefore all digital inputs to these modules with no resistive line monitoring components require a 1K 0.6W resistor in series with the line, to create a voltage drop. Product Description PD-T8842 describes where the resistor should be fitted for each circuit type. In most cases the resistor can be fitted on the VFTA.

Configuration

T8448 and T8449 inputs may be monitored by the application through either the STATE or the AI boards on the equipment definition. There is no Boolean point available for digital inputs.

The AI board provides the measured voltage in 500^{ths} of a volt (0V = 0, 24V = 12,000 etc.) This can be changed to engineering units with a conversion table, as for analogue inputs.

The STATE board reports a numerical state according to threshold settings, exactly as for digital input modules (except the voltage scaling is slightly different). Refer to the section on Digital Input Thresholds above. The STATE input is an integer and reports 2 for off/open and 4 for on/closed.

Note that the LINE_FLT board will provide the same fault status as for digital inputs above.

Frequency/Pulse Inputs

The T8442 Speed Monitor Module is designed to monitor the speed of a rotating machine (turbine etc.) and provide over-speed and over-acceleration trip outputs to a very high integrity. Its normal purpose is described in its Product Description PD-T8442. This document covers possible alternative uses.

It is therefore ideal for measuring frequency inputs up to 30,000Hz with an accuracy of 1Hz or 0.01%, whichever is greater. However, it does not provide a count of pulses, so it is of no use as an accurate flow total integrator. A pulse count can be interpolated by multiplying the current speed by the latest scan time (measured using a timer variable), but this is only moderately accurate.

The module must be used with its dedicated FTAs T8846 (all inputs) and T8891 (one set of outputs) and I/O cable TC-801 which connects the module to all FTAs. The cable is shown below. This cable allows Companion Slot operation; there is no SmartSlot cable.

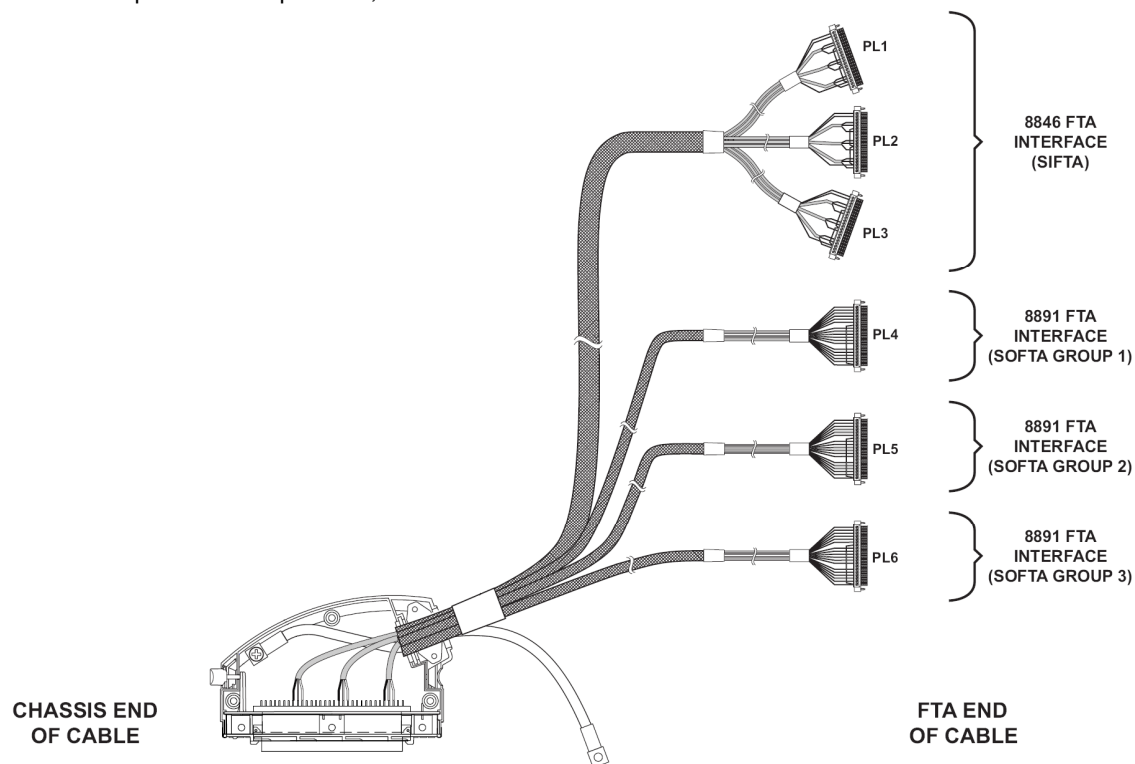

The T8846 FTA allows connection of:

- Active totem pole outputs, device powered from FTA or externally
- Active open collector outputs, device powered from FTA or externally
- Passive inductive sensors

Connection for each device is described in PD-T8846.

If the T8442 is used for pulse/frequency measurement without need for over-speed and over-acceleration trip outputs, the T8891 FTAs are not required. These must be declared as absent in the system configuration in the Speed Monitor template assigned to the module. For each group, uncheck 'SOFTA Present'; this turns off the module's diagnostics of the FTAs. Note that firmware build 133 or later (TUV release 3.5.1) is required to turn off the diagnostics. This firmware is fitted in modules with a manufacturing build label showing a number 2 (e.g. F2).

Digital Outputs

Power Groups

Digital Output module channels are arranged in groups of eight. Forty channel modules therefore have five groups, thirty two channel modules have four and sixteen channel modules have two.

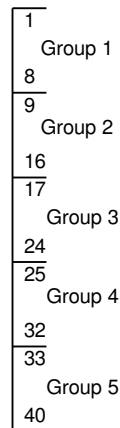

Each group is isolated from each other, allowing different supply voltages to be used for each group. Each group has a triplicated switch in the supply line allowing the whole group to be turned off if a fault cannot be isolated; this is the group failsafe switch (GFSS). The GFSS has a parallel set of three switches, one controlled by each slice. These are failsafe, so that if a slice is set offline, its switch is opened. This switch allowed TUV to permit the system to operate indefinitely with one fault, because there is still a means to shut down the outputs.

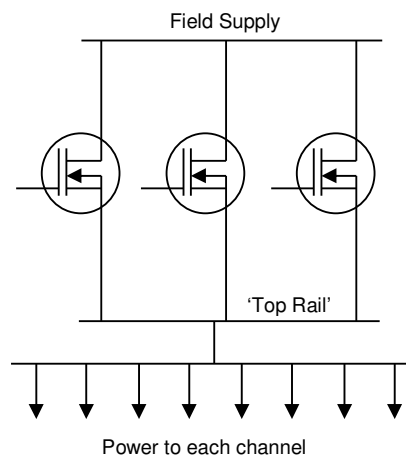

'Top Rail' is used as the reference point for the channel voltage calculations below, and is about one 'diode-drop' below the incoming field supply voltage.

Line Monitoring

Outputs do not have threshold templates. Instead, the state of an output is determined automatically by measurement of its voltage and current with few user-definable settings. The state is the module's measurement of the output condition and is not the same as the output command. Each of the three slices of an output module makes a judgement on the state of the output. The majority vote is reported to the application through the STATE board. If one slice reports a different state, the channel is reported as discrepant with a 70nn series slice fault and a bit is set in the DISCREP channels.

The states are described in the sections below. They refer to the thresholds shown in this table. Note that the values for T8451 also apply to T8448 and T8449. The field supply voltage measurement is after a semiconductor drop through the Group Failsafe Switches (GFSS), so the figures below have been raised by 0.5 volts to reflect the true value. The Off and On thresholds are measured from the field supply voltage downwards, so they will vary with the field supply voltage (and a volt has been added). The measurement is negative because the FET switches in the output circuits are high-sided and thus measurements must be referenced to the top rail (see 'Power Groups' above). The No-Load threshold is user-adjustable and is explained in a later section.

	T8451 to rev. G	T8451 from rev. H ('LV2')	T8461	T8471
Minimum field supply voltage	11.5V	11.5V	12.2V	34.5V
No load threshold per slice (adjustable)	10mA	10mA	10mA	10mA
Off threshold (below supply)	-15.3V	-15.3V	-16.7V	-87V
High On threshold (below supply)	-1.3V	-4.5V	+2.3V	-27.5V
Low On threshold (below supply)	-4.5V	-5.5V	-5V	-82.5V

No field supply voltage (state 1)

This state is reported when the measured field supply voltage for the power group is below the minimum threshold. It is possible to run a module with a low supply voltage. The switching circuits will work, and the output will be energised and de-energised by these switches. However, all channels will report state 1, which effectively means there is no line monitoring.

Output de-energised/off (state 2)

This occurs when an adequate field supply voltage is present and the voltage is below the Off threshold. This demonstrates that the output has successfully switched off and there is no residual voltage on the loop.

Open circuit in field wiring or load (state 3)

This occurs when:

- for energised outputs, an adequate field supply voltage is present and the measured current is below the no-load threshold. This is a common source of 7000 series slice discrepancy faults, if one slice is starved of current by the passive sharing between slices.
- for de-energised outputs, an adequate field supply voltage is present, loop current is below the no-load threshold and the channel voltage is between the low and high On thresholds.

AN-T80004 Field Loop Configuration

Output energised/on (state 4)

This occurs when the channel output current is above the no-load threshold and below the short circuit limit, an adequate field supply voltage is present and the voltage is above the Off threshold. This proves that the output is energising the load and the load is within the module's specification.

Short circuit in field wiring or load (state 5)

This is detected by separate logic that monitors the output current. The logic acts to allow excess current as far as the circuit can stand. Nominal continuous ratings are 2A for T8451, 0.75A for T8461 and 0.5A for T8471.

Field fault (state 6)

This occurs when a de-energised output has an adequate field supply voltage, the measured current is below the no-load threshold and the voltage is above the high On threshold or between the low On threshold and the Off threshold, which implies it is externally biased to a voltage (e.g. supply voltage). This will occur with hardwired matrix lamp tests on outputs driven from Trusted modules.

Channel fault (state 7+)

This state, and any number up to 15, indicates that the module is faulty. When the system considers a channel faulty on a slice, the state is set to 15. The top bit indicates a module fault. The STATE variable can be collected in the digital SOE buffer but only the lower three bits are recorded, so it will appear as a 7 over SOE.

For clarity, the effect of the voltage thresholds is shown here as a graph.

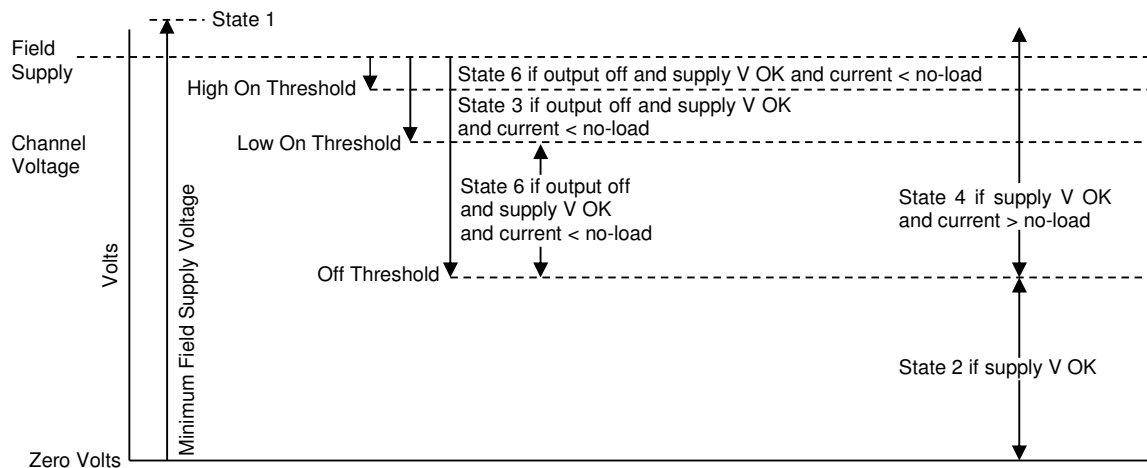

No-load (Open Circuit) Threshold

Triplicated Modules 8448, 8449, 8451, 8461, 8471

(See later for 8472)

The No-Load threshold settings are a common cause of confusion, leading to copying of settings from other configurations without understanding. For this reason they are covered in more detail here.

The no-load threshold is a current in milliamps per channel slice below which the channel is declared open circuit.

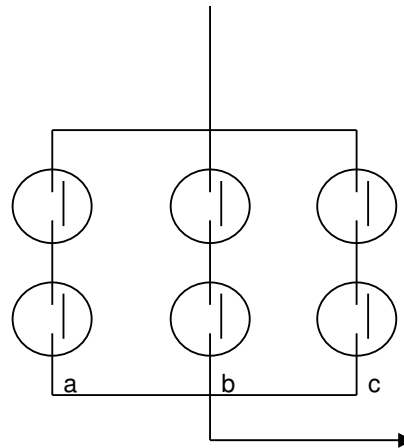

The diagram above shows the FET switches in a single output channel (in simplistic detail). The output channel is switched by the three slices of the triplicated circuit, each of which measures the current through one leg of the circuit. The total channel current is thus the sum of the current through the three legs.

However, the circuit does not share the current evenly. It is quite possible for the current in one leg to be twice that of another leg. For that reason, the channel current at which a no-load is declared may be four or five times the no-load threshold.

The no-load threshold is also used as a detection of cross-talk or noise on de-energised channels. If there is more than the no-load threshold current on a de-energised output, then there is significant leakage, and this is a serious problem in a safety system, to the point that the slice may be isolated by turning it off. A combination of heavy switching loads and a low no-load threshold makes a false positive on these diagnostics more likely. There is also a known cross-talk from channel 18 of an 8461 to some adjacent channels (see technical note TN20031), which will make the problem even more likely if channel 18 has a heavy load.

The no-load threshold can be set for each power group, e.g.:

$n\text{ltresh} = 3,5,10,15,20$

sets a no-load threshold of 3mA per channel circuit leg on outputs 1 to 8, 5mA on channels 9 to 16, 10mA on 17 to 24, 15mA on 25 to 32 and 20mA on 33 to 40. Since the threshold can be set for each power group, it is better to group similar power demands on each group (e.g. don't mix sirens and LEDs). Then apply a no-load threshold that is comfortably below the minimum expected slice current.

The default no-load threshold is 10mA. This will be suitable for any load greater than 50mA. It has been common practice to specify $n\text{ltresh} = 5,5,5,5,5$ i.e. 5mA on all groups. This allows loads down to about 25mA to be recognized properly, and usually recognizes loads down to 20mA if the current balancing is good. However, with very heavy loads in the same group as LEDs and relays, there may be problems with a 5mA setting. 10, 15 or 20mA are more appropriate for heavy loads; see TN20031 and Product Description PD-8082 section 2.3.10.

AN-T80004 Field Loop Configuration

It is advised to add load resistors to loads under about 20 to 25mA to increase them above the minimum threshold. It is also possible to apply a threshold of 3mA to a group, but only if the group has entirely light loads; this setting will otherwise clearly increase the chances of noise causing a false positive diagnosis, causing a potential shutdown.

Quad Structure Modules 8472

This module does not have the triplicated output circuit described above. Instead, it has a quad arrangement of switches. The no-load threshold applies to the entire load current, so a threshold of 20mA allows a minimum load of 20mA. The default is 10mA on older 8472s and 20mA on newer 8472s, as shown in the specifications in the product descriptions. The no-load threshold should not be set to less than the default value.

Termination

Powered digital output terminations are very simple, with minor additions to suit each module type.

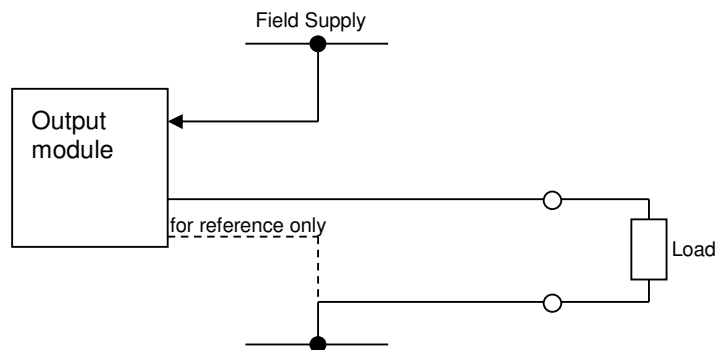

The above diagram is complete for T8448 and T8449 outputs, T8451 and T8461. T8471 requires 330K resistors (0.25W) in parallel with the load and also on unused channels, to provide termination to the diagnostic tests, so they can distinguish between an open circuit and a stuck-on fault. These are fitted to the T8870 field termination assembly (FTA). The T8871 FTA, used for the T8472, has transient protection components.

The zero volt return is taken back to the supply outside the module. A connection is made to the module for measurement of the field supply voltage.

Digital outputs do not require fusing because the modules dynamically control the output and protect against short circuit. In the event of a short circuit, digital outputs will de-energise until turned off and on again or the processor Reset button is pressed, when the module will try to energise the output again.

T8842 VFTA

The T8842 Versatile Field Termination Assembly (VFTA) provides individually configurable channel circuits and is essential for the T8448 and T8449, but could also be used for the T8451 and T8461. It also provides three-wire connection (24V supply, signal and zero volt reference). It requires a VFTA cable TC-209, 210, 509 or 510. Circuit configuration is given in PD-8842.

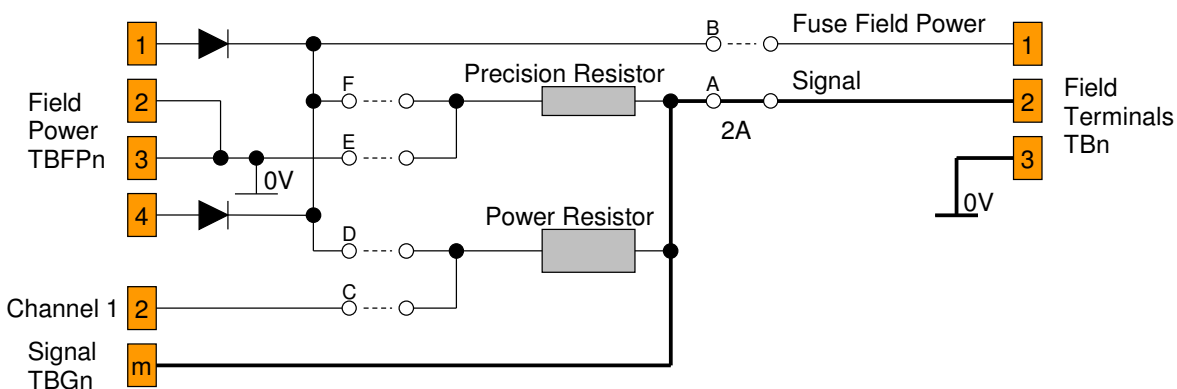

For digital outputs, the resistors play no part in the circuit, which is shown by the bold lines. The 2A fuse is only used as a link and is not a circuit protection.

T8850 and T8870 FTAs

The T8850 and T8870 FTAs are also a simple straight-through connection, but also include power supply indicating LEDs. However, these are only relevant if using integral power cables, where the field power is wired to the FTA and connects through the I/O cable to the module. The T8850 is designed for 24V dc operation but would be appropriate for 48V dc operation if the power supply indicating LEDs are not connected. The T8870 is designed for 120V dc operation for the T8471. It also includes 330K resistors across each channel to terminate the T8471 diagnostics. The T8472 requires its own FTA which is covered later.

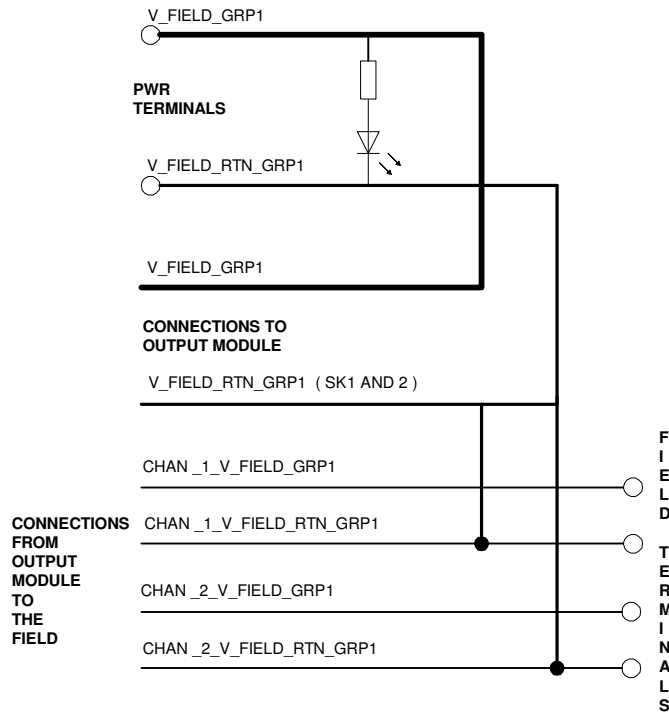

Two variants of I/O cable may be used with these FTAs.

'Integral power' cables include five 2.5mm² wires to carry the field power supply from the FTA back to the module. These cables are TC-215, 217, 515 or 517. These are appropriate where the power supplies are fitted near the FTAs in a marshalling panel which is separate or distant to the system.

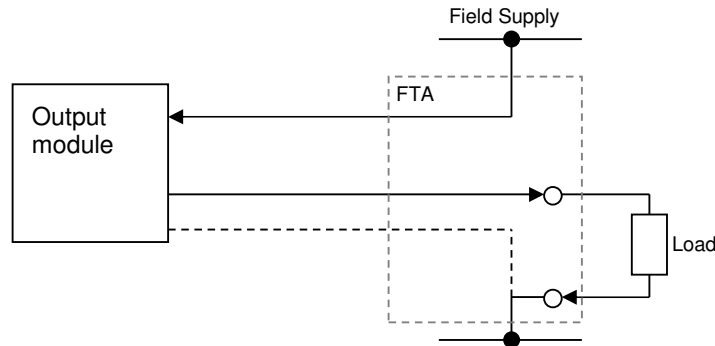

The power supply positive and negative connections should be connected to the PWR TB terminals on the FTA. This will also energise the FTA's power group LEDs, and so this arrangement can only be used at the rated voltage of the FTA.

AN-T80004 Field Loop Configuration

'Standard' cables have two short tails on the chassis end. These cables are TC-205, 207, 505 or 507. One tail connects to the field power supply via a T8290 or T8297 distribution unit. The other connects to the power supply zero volts to provide a reference to the module for measuring the supply voltage, through a plug which fits onto a T8290. The power return is still connected to the FTA, but the FTA has no supply connection (so there is no point in wiring the five supply terminals on terminal block PWR TB to the field supply).

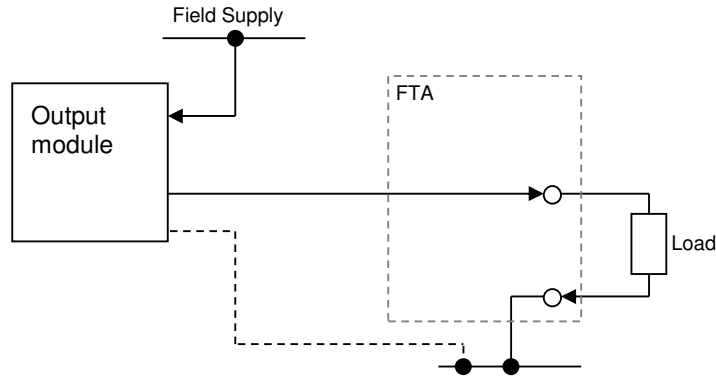

Power Termination

The T8290 is appropriate for digital outputs, because it provides simple termination of the field supply and zero volt reference. The T8297 does not have termination for the zero volt reference; instead it has diodes for bridging low current power supplies. It is therefore appropriate for analogue outputs or for very low power digital outputs.

It is recommended to supply the Trusted system and field circuits with fully separated dual supplies. This ensures that a fault in one supply (e.g. a busbar short) will not cause a fault in the other supply and bring the system down or cause shutdowns. Application note AN-T80005 demonstrates how to design the power supplies. Bridging diodes are fitted in all modules wherever the dual supplies are joined, except for digital output power. Therefore the dual supplies for digital outputs should be passed through high current diodes mounted on suitably rated heatsinks before connection to the T8290 or T8297 studs, which simply link the two supplies together.

The T8290 is rated at 60A. The T8297 studs are also rated at 60A and connect directly to the power sockets in the same way as the T8290. A T8297 may be used for combining digital output power, given that the zero volt reference connections are taken to the power supply by other means. The T8297 also has a central terminal block for connecting field power, which is wired through bridging diodes. This is ideal for analogue outputs, but the diodes are not adequate for digital outputs.

I/O cable TC-219 provides free wire terminations (instead of plugs) for supply power and zero volt reference when using T8850 or T8870 FTAs. There is no TC-519. This allows custom terminations for power supplies instead of T8290 or T8297.

Refer to application note AN-T80008 for information on protecting individual supply connections.

T8472 Termination

The T8472 is terminated using the T8871 FTA and special cables TC-221 and TC-521. The terminations are described in the product descriptions for these parts. AC power (L,N,E) is connected at the FTA on two separate terminal blocks for the two power groups and is fed back through the cable to the module. TC-521 requires a special hot-swap jumper cable TC-310-02.

Terminating Resistors

Unused outputs should be commanded off/de-energised. These need a resistor to satisfy the diagnostic logic, which is wired from the channel output to zero volts. This also prevents the need to force channels to a healthy state.

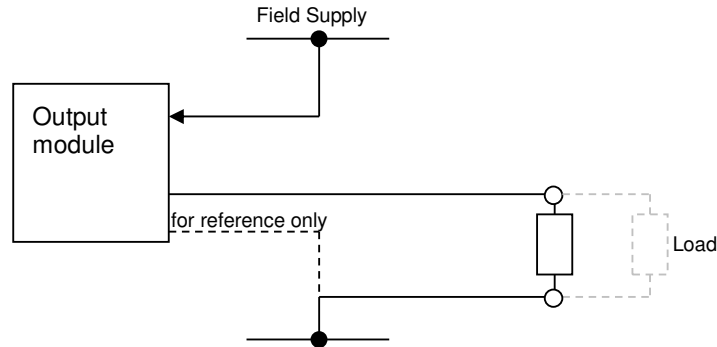

The following values will drain sufficient leakage current to move the channel voltage down to the state 2 (off) range.

T8448, T8449, T8451	4K7 0.5W
T8461	10K 0.5W
T8471	330K 0.25W (already fitted to T8870 FTA)
T8472	33K 2W

Low current digital output loads may need the addition of a parallel resistor to increase the current drain above the minimum load. This is common when the output drives miniature relays, matrix lamps or high impedance inputs, e.g. to other systems. I/O module event logs often fill with field fault states, and it is worth minimising the causes.

The minimum current should be set to five times the no-load threshold, to ensure that all three slices have enough current to detect the load. Parallel resistance should be added to draw the extra current required. If the field load is approximately half of the total, it is likely that a field open circuit will still be detected because all three slices will detect insufficient load. If the resistor can be fitted locally across the actual load, then the cable is still line monitored.

Volt-free outputs

All the termination details in the previous sections assume that the system powers the load with its own supply. This allows full line monitoring for most devices. However, relays are often fitted in output circuits to isolate systems.

If an output is safety related, the relay should be a certified safety relay. These have different designs to satisfy requirements, and fall into two basic categories.

Force-guided contacts have a higher guarantee that the contacts will move. The contacts are joined together and pushed directly instead of relying on their spring tension to return them to the de-energised position. Spare contacts in this set could be used as auxiliary feedback contacts to prove to the system that the contacts have moved, via a digital input. Force-guided contact relays are relatively cheap and follow the EC Machinery Directive.

Some safety relays have dual or multiple redundant circuits with co-ordinating electronics. These are designed to guarantee that the relay can move contacts to the de-energised position, for de-energise-to-trip applications (e.g. ESD) and are more expensive. Electronics in the relay monitors the coil and contact state and will prevent the relay from energising if a fault is detected. These add SIL-specified integrity to de-energising applications but are a hindrance to energise-to-trip applications, e.g. F&G, where a good quality basic relay would be better.

AN-T80004 Field Loop Configuration

If the relay load current is less than the minimum, an extra load resistor is required as described in the previous section.

Hazardous area outputs

Digital outputs are not intrinsically safe or non-incendive. Separate power-limiting devices should be fitted to satisfy the regulations in force. For EEx 'd' devices, mounted in sealed explosion-proof housings, direct connection is allowed because the device housing provides the protection.

Device Characteristics

Digital output line monitoring algorithms expect the output current and voltage to be predictable. This is adequate for linear loads (e.g. resistive, inductive), but many field devices do not present simple loads.

Low current loads

Minature relays, LEDs, lamps and PLC inputs usually have insufficient current to satisfy the channel diagnostics. These should be fitted with load resistors as described above.

Some low current loads can have unusual effects on the diagnostic tests due to nonlinearity. For example, a filament bulb has a very low resistance when cold and may appear as a short circuit when first energised. On firmware versions from TUV 3.5, the output drive logic will drive a short circuit with more determination, whilst protecting the output switches from overheating.

Another example is a load which appears open circuit until adequate voltage is applied; this can frustrate ramp tests for open switches (fault code 0x63nn). This has been seen with LED lamps. The solution is to assume that the load itself has no effect on the impedance seen by diagnostic tests and to add parallel resistors to provide the minimum current at all times.

Dynamic loads

These loads draw irregular current and include strobe beacons, pulsing sirens and other devices that draw intermittent current. These may temporarily draw more than the maximum rated current or less than the minimum load, or even both. When energised, the channel state will not stay continuously in state 4 but will switch to 3 (low load), 5 (short circuit) or even 6 (field fault). This can cause discrepancies which will be indicated as slice faults, when one slice measures a transient at a different point to the other two slices. All transitions in and out of fault states are indicated in the I/O module event logs.

If state 3 is seen, add load resistors as above.

If state 5 is seen, ensure that the digital output module has firmware installed to TUV release 3.5 or later. This is indicated by a firmware version 130 and a manufacturing build number 38 for T8448, T8449, T8451 or T8461, 39 for T8471 and 18 for T8472. This release improved handling of short circuit detection. If release 3.5 output module firmware still reports short circuits on loads apparently within its rating, replace or refit the device to smooth out its demand peaks.

If state 6 is seen, the load is dynamically 'tri-stating' or otherwise changing the impedance, which causes the voltage to change. Add a load resistor as for low current loads, to ensure the voltage remains steady. The output module's voltage sensing circuit causes the line voltage to be lifted to the state 3 region (see page 27) during a true open circuit. A T8461 from hardware build I and a T8451 after build H ('LV2') have an impedance of about 66K to a reference point two volts below field supply voltage. A T8461 before hardware build I has an impedance of about 33K to one volt below supply voltage.

Maintaining line monitoring with devices that go high impedance when de-energised is difficult; the best solution is to add a bleed resistor across the load to lower the open circuit voltage to the state 2 region. Suggested resistors are given in the 'Termination' section of each output module product description (these sections discuss the termination of unused outputs, but the reason is the same). Note that there must still be adequate power available through any I.S. barrier to allow the device to be energised.

Caution

Devices that cannot be reliably line monitored when de-energised must not be used for safety related energise-to-action applications.

State 6 may also be caused by external lamp tests, or otherwise when the outputs are powered from an external source. It is recommended to configure lamp tests through the system application so that there are no secondary connections powering the load. Module diagnostics may detect external supplies as 'stuck-on' faults which will lead to a module shutdown.

High inrush current loads

As for dynamic loads above, release 3.5 firmware or later will improve handling of inrush currents; it will pulse-drive a heavily capacitive load until the current falls within specification. There are no user-replaceable fuses in a Trusted digital output module; instead a DSP algorithm dynamically monitors the load. Before release 3.5, capacitive loads were often reported as short circuits. On detecting a short circuit, the module de-energises the output.

Note that inrush currents can occur with small filament bulbs as well as bacons and sounders. This is due to the very low cold resistance of the filament.

If inrush current is still a problem even with firmware from release 3.5, replace or refit the device to smooth out its demand peaks. Some devices can be fitted with optional 'soft-start' modules to smooth the current demand.

Power supply fluctuations

It is possible that a heavy load may drag the supply voltage down, either on energising/de-energising or with a constant noise signal. Some module diagnostics routines rely on measurements of the field supply voltage. If the voltage changes significantly during a test, the diagnostics may report a fault. This may lead to a slice going offline.

Ensure that the power supply is able to sustain a stable voltage during heavy switching demand. At release 3.5 output module firmware, the outputs will pass considerably more current whilst trying to energise a load (for example, the 'Field Fault' switches on a demonstration kit will bring down the 24V supply with this firmware).

Analogue Outputs

The Trusted T8480 Analogue Output module may be considered as a current controlled digital output module and it has similar termination and characteristics. The specific differences are listed in this section.

Module circuit

Like digital output modules, the T8480 has channels arranged in power groups, each supplied by a common failsafe switch.

Instead of six FET switches, the T8480 has three current controlling switches and three shutdown switches. The demand current is divided between the three slices which interact and ensure that the total loop current remains as constant as possible during module faults and hot-swap pairings.

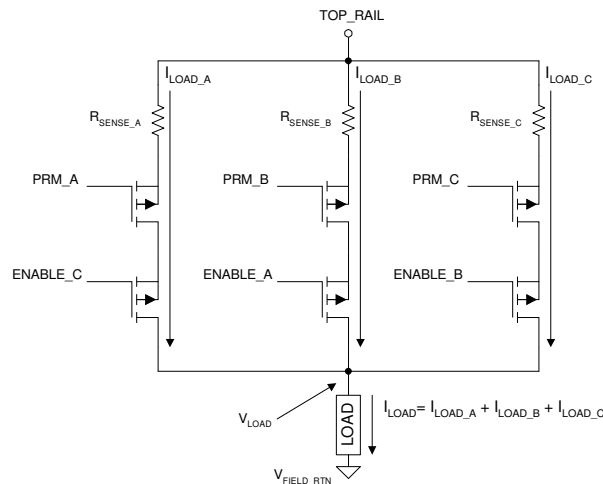

Line Monitoring

There is no no-load threshold for analogue outputs.

The states reported by an analogue output are similar to digital outputs, and are summarised below.

No field supply voltage (state 1)

This operates in a similar way to digital outputs. The module cannot guarantee to supply the required current if it has insufficient supply voltage (for comparison, digital outputs will still switch but the diagnostics is blind).

Output de-energised (state 2)

This state occurs with a load fitted when the current demand is negative.

Open circuit in field wiring or load (state 3)

This occurs when the load impedance is too high for the channel to drive the required current, but the supply voltage is acceptable.

AN-T80004 Field Loop Configuration

Output energised (state 4)

This state occurs with a load fitted when the current demand is zero or positive and is thus the expected state of a healthy output.

Current demand cannot be met (state 6)

(There is no short circuit state 5 for analogue current outputs; the channel will drive a short circuit with the required current).

This occurs when the required current exceeds the capabilities of the channel.

Channel fault (state 7)

This is a module fault and operates in the same way as digital outputs.

Termination

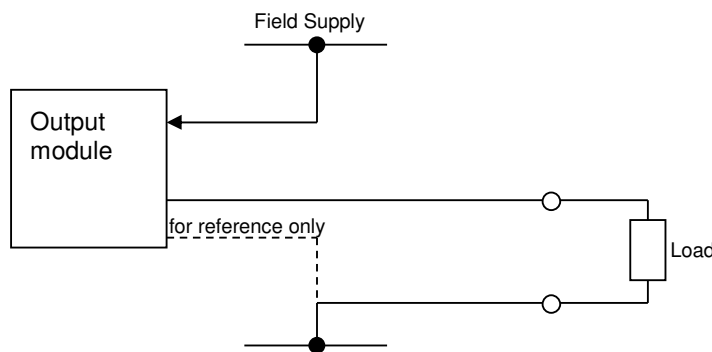

Termination for system powered analogue outputs is very similar to digital outputs; the schematic diagram above is identical. The T8842 VFTA and the T8850 FTA may be used as described for digital outputs. There is no need to add termination resistors to outputs, indeed this will cause errors in the loop current. Unused outputs may be wired to zero volts directly to satisfy diagnostics.

If using the T8850 FTA and I/O cables with power connection at the chassis end, the T8297 power distribution unit should be used to connect field power. Wire the A and B supplies to pins 1 and 2 of the central terminal block TB1; this connects the supplies together after passing through the 6A diodes on the unit. The zero volt connections must be taken to the supply return separately so that the module can measure the supply voltage.

Hazardous area outputs

The T8480 analogue outputs are not intrinsically safe or non-incendive. Separate power-limiting devices should be fitted to satisfy the regulations in force. For EEx 'd' devices, mounted in sealed explosion-proof housings, direct connection is allowed because the device housing provides the protection.

Pulse Outputs

Applications have occasionally required pulse-width modulated outputs. These may be used to control valve positioners using open and close pulses. Other applications may require accurate control of output pulse times.

The T8449 Valve Monitor module is normally used to add valve testing to an output drive. The output is briefly switched to the opposite state and the feedback input channel is monitored by the module to check that the valve has moved. If the valve does not reach the test target position within a time limit, the test is cancelled and the output is reinstated.

If a test is requested which cannot succeed, the output will pulse for the time limit setting, with an accuracy of about 7ms. This may be used to generate output pulses for pulsed applications. Each 'valve test' is configured and demanded by the application as required. If the output is energised, the output is switched off for the 'test' time limit. If the output is de-energised, the output is turned on for the 'test'.

'Tests' are demanded by a rising edge on a Boolean output. The application must therefore run two scans to turn the output off and on to demand a pulse. This is the fundamental limit to the pulse frequency.

Four variables need to be connected to the T8449 I/O definition.

Output Boolean output. Signal to drive steady output state on or off. Wired to odd-numbered DO_TEST channel.

DO_Test Boolean output. Signal to demand a pulse on a rising edge. Wired to next (even numbered) DO_TEST channel after 'Output'.

ETime Integer output. Pulse width in milliseconds 0 to 32767). Wired to odd numbered ETM_EST channel (same channel number as 'Output').

End_State Integer output. A target state number for the test, one which should never occur on the unused input (e.g. 5). Wired to next (even numbered) ETM_EST channel after 'Etime'. This variable should be given an appropriate initial value and does not need to be changed by the application.

The example below shows two channels configured for pulsing. These are controlling positive/opening and negative/closing pulses to a valve positioner.

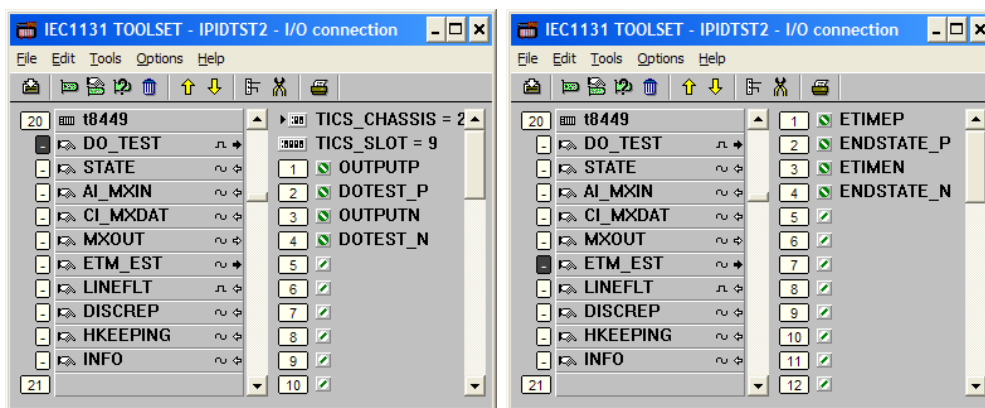

To demand a pulse, set ETime to the required width and set DO_Test from False to True.

A function block has been written to control the opening and closing pulses described above. This provides the three dynamic outputs needed for the connections shown above. Its inputs are described below.

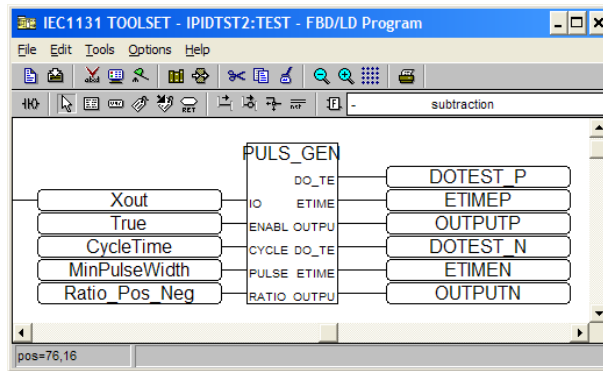

IO	Real	-100% to +100%
		Pulse width from continuous off demand to continuous on demand.
ENABLE	Boolean	True to enable pulses
CYCLE_TIME	Integer	Pulse spacing in milliseconds
PULSE_MIN	Integer	Minimum pulse width in milliseconds (smaller pulses are ignored)
RATIO_POSNEG	Real	Pulse width bias factor (1.0 = linear)

If the pulse width bias factor is 1.0, the function block will demand the following pulse output:

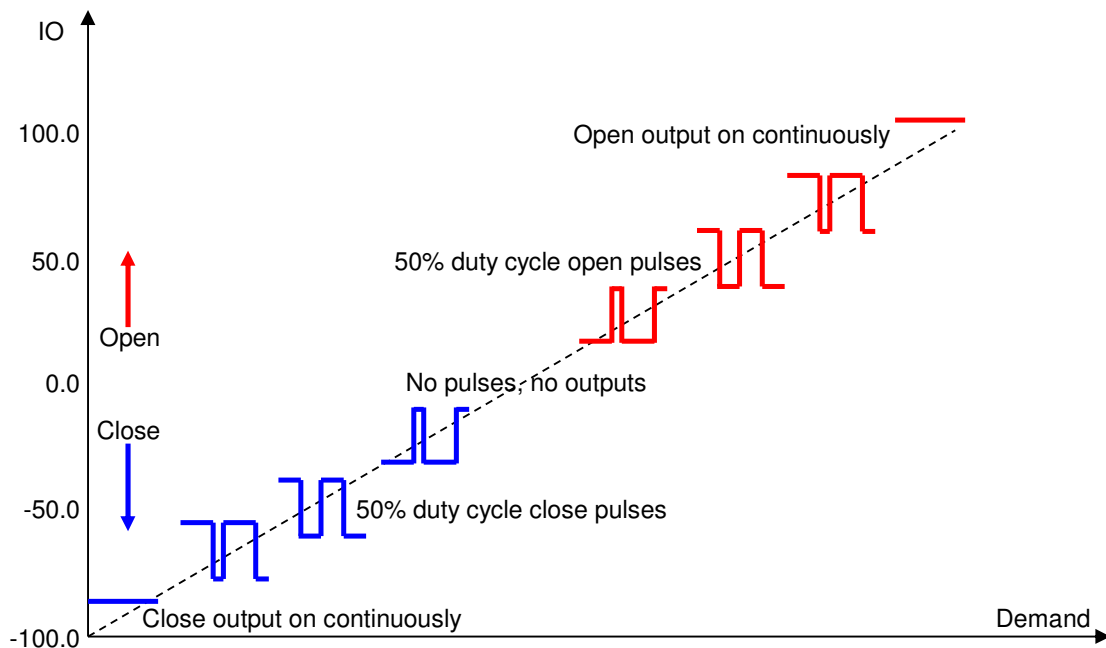

AN-T80004 Field Loop Configuration

The pulse width bias factor is used when the valve moves faster in one direction than the other for the same pulse width. It has the following effect on the output.

Bias factor = 1.0 Mark-space ratio = IO input

Bias factor < 1.0 'Closing' pulse ratio is multiplied by bias factor. 'Opening' pulse ratio is unaffected.

Bias factor > 1.0 'Opening' pulse ratio is divided by bias factor. 'Closing' pulse ratio is unaffected.

A bias factor of 2 will result in an opening output pulse width of 50% for an input of 100%. A bias factor of 0.5 will result in a closing output pulse width of 50% for an input of -100%.

The function block is available from ICS Triplex Technology. Contact support@icstriplex.com.

Other Issues

System Cable Design

The diagrams below show how to wire the system I/O cables and power supplies for each type of termination and cable design. Cable choices are shown in the cable PDs TC-200, TC-500, TC-600 and TC-700.

'Internal' cables are protected with a nylon braid and are suitable for use inside a single panel. 'External' cables have a sheath but are not armoured and are suitable for routing within a building but not in trenches.

Analogue or Digital Input module to FTA

Wire the 24V supplies through 3A fuses; the T8193 is designed for this.

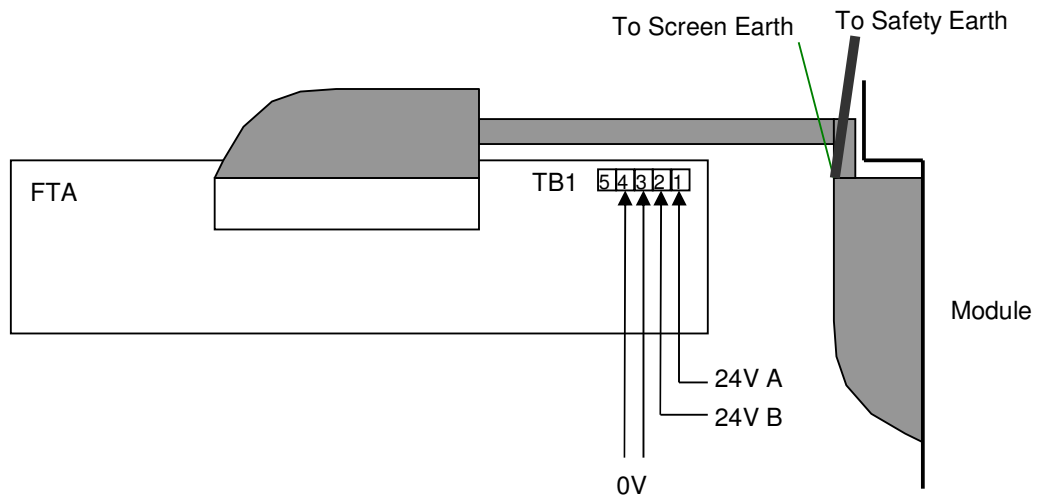

Analogue or Digital Input module to VFTA

The T8842 VFTA has five power supply plugs. Each plug powers one 'power group' of eight channels (see page 28). For field devices that require only milliamps to drive the loop current, only one dual 3A supply is needed and the plugs should be linked together. For field devices that require more current, each plug may be wired from a dual 3A supply. If 3A is not enough for eight channels, fit separate 24V and 0V fused terminals for each channel. The diagram below shows only one 3A dual supply for low current devices, with wire links between the terminals.

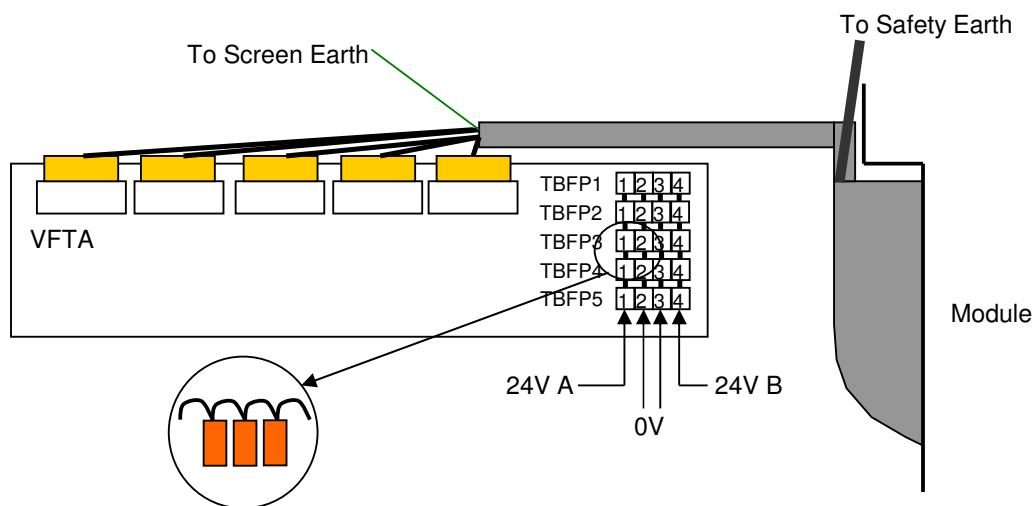

Digital Output module to FTA, Standard Cable

The 'standard' output cables TC-205, TC-505, TC-207 and TC-507 have power connections at the chassis end for a T8290 distribution unit. The dual feeds are linked on the block and wired through five cores to each power group in the module (see page 28). The module switches each load, and the power to each load is wired to the FTA through the I/O cable. The zero volt return from the load is wired back to the power supplies through the FTA.

There is no need to wire the five 24V connections of the FTA to 24V if using a standard output I/O cable. This will only light the FTA LEDs; it does not power the module's field supply.

The two 24V supplies should be wired through two bridging diodes for each module, each capable of passing the full current of all the module's outputs, fitted on heatsinks. If one power supply is shorted, the diodes will protect the outputs (and the rest of the system) from being shorted.

The module has another connector which provides a zero volt reference for the module's internal voltage measurements. This fits on the T8290 unit. Pins 1 and 2 of the centre connector should be wired to zero volts to provide the reference.

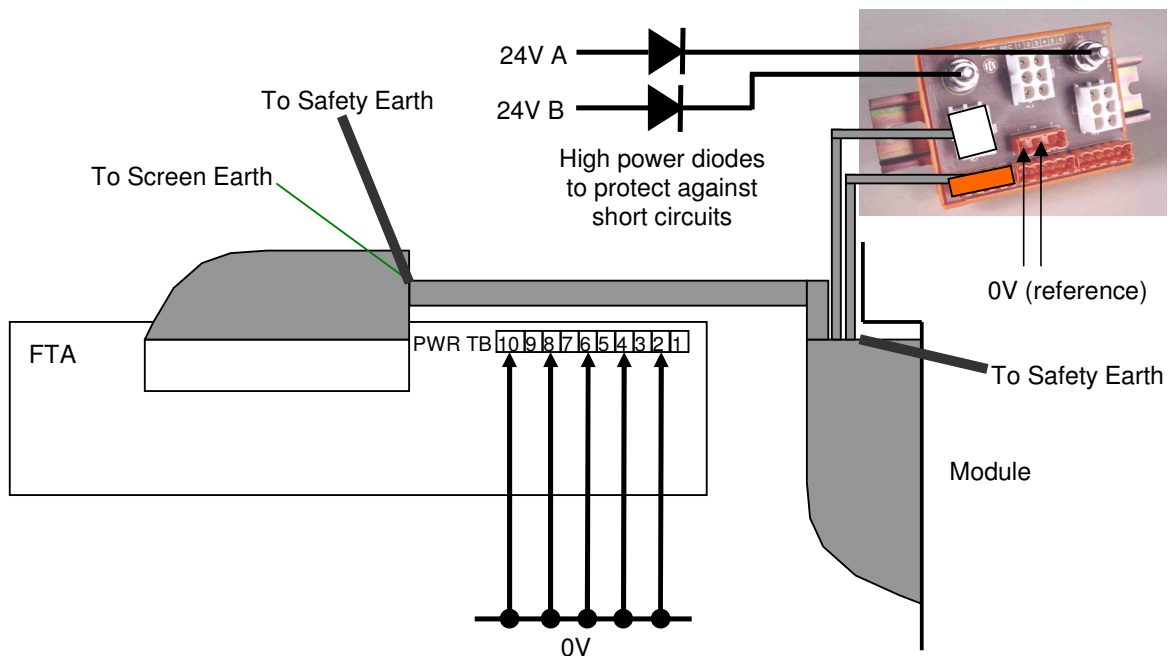

Digital Output module to FTA, integral power cable

The 'integral power' cables TC-215, TC-515, TC-217 and TC-517 have five extra cores from the module to the FTA so that power can be supplied at the FTA. This is appropriate if the power supplies are mounted with the FTAs and are distant from the system panels.

The power for each of the five power groups is wired to the FTA. This should be taken from bridged dual supplies, as for 'standard' power cables above. The supply is wired to the module through the five extra cores. The module switches each load, and the power to each load is wired to the FTA through the I/O cable. The zero volt return from the load is wired back to the power supplies through the FTA.

There is no zero volt reference connection at the module end. Note that the five power groups can be supplied from different voltages if required, but the zero volt returns are linked together on the FTA.

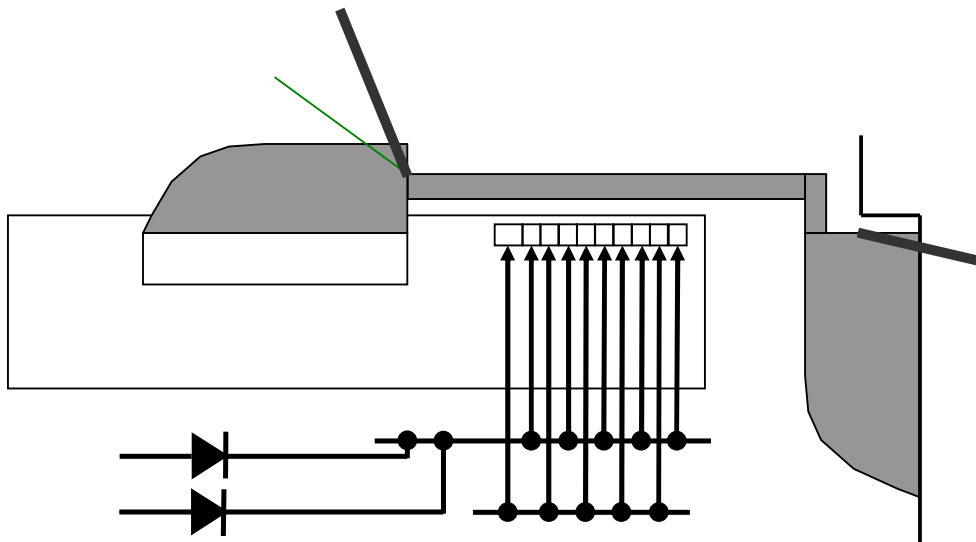

Digital Output module to VFTA

The TC-209, TC-509, TC-210 and TC-510 cables have power connections at the chassis end for a T8290 distribution unit. The dual feeds are linked on the block and wired through five cores to each power group in the module (see page 28). The module switches each load, and the power to each load is wired to the VFTA through the I/O cable. The zero volt return from the load is wired back to the power supplies through the VFTA.

There is no need to wire the 24V connections of the VFTA to 24V supply. The VFTA's power distribution circuits are unused in this configuration.

The two 24V supplies should be wired through two bridging diodes for each module, each capable of passing the full current of all the module's outputs, fitted on heatsinks. If one power supply is shorted, the diodes will protect the outputs (and the rest of the system) from being shorted.

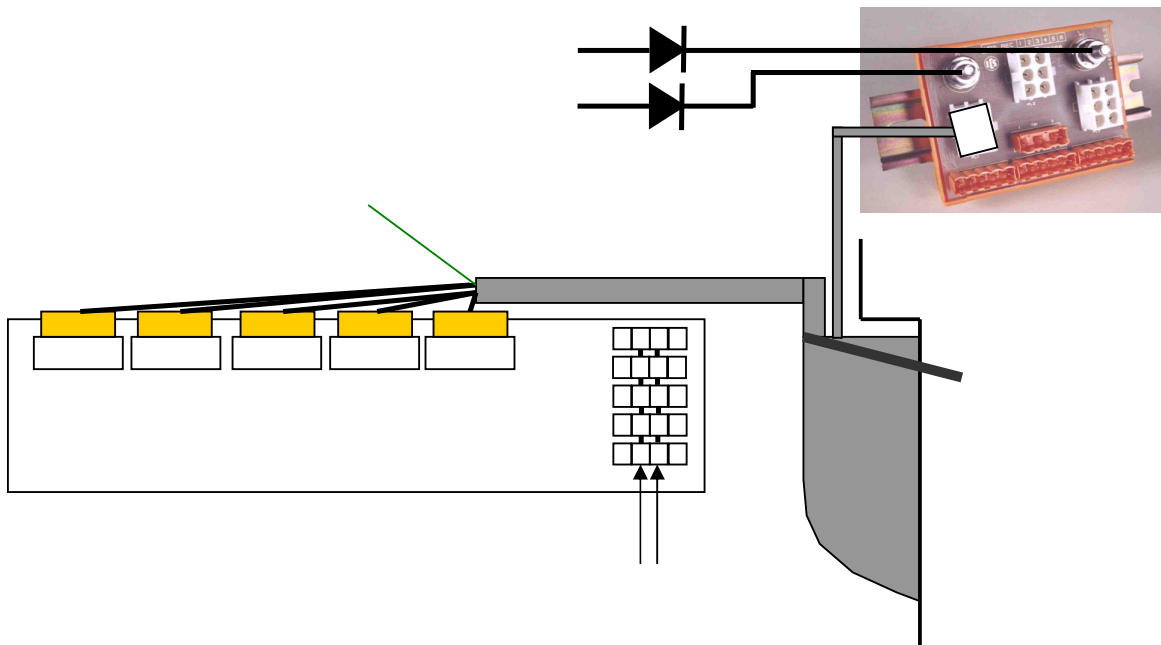

Analogue Outputs

Analogue output circuit options are the same as the digital output options above. However, the heavy power diodes and heatsinks are not necessary for analogue outputs. The T8297 distribution unit includes two diodes for analogue output power bridging. The T8297 can be used with either the FTA 'normal' cables or the VFTA cables shown above for digital output modules. The same cables are used for digital and analogue outputs.

The 24V supply should be wired to the centre connector and not to the studs.

The example below shows an FTA. A VFTA may also be used.

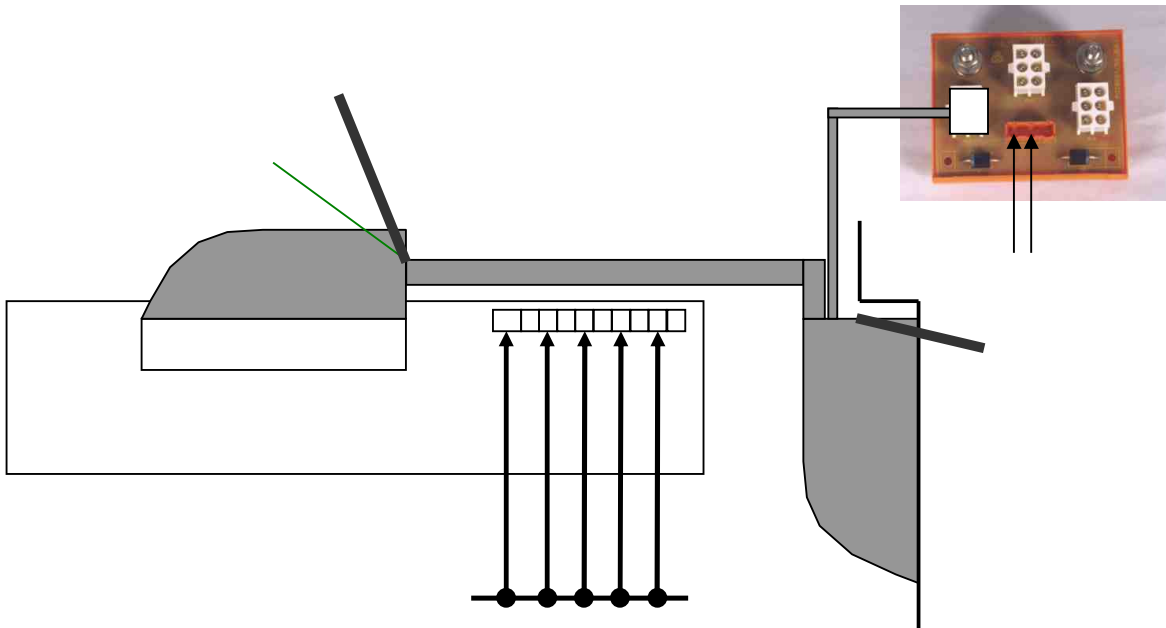

Floating Earth Systems and Loop Isolation

ICS Triplex Technology recommends that system zero volt references are well grounded. This simplifies fault finding; the first earth fault will have a single effect on the field loop on which it occurs. Whilst floating earth systems can survive a single earth fault, they are very unlikely to indicate the position of the fault. Multiple faults can cause random scattered effects which are often impossible to diagnose.

However, at many sites there is no possible secure earth, since the ground is too dry. If an earth point cannot be reached, the alternative is to isolate all I/O individually. If each field loop is isolated, a fault will only affect the loop on which it occurs.

Each loop should be isolated at the system end. If the loops are only isolated in the field, then a fault on one loop can still affect other loops. Inputs may be isolated using separate isolating devices or by using isolated input modules. Output modules may be considered as isolated per power group, i.e. each group of 8 outputs can have a separate supply and zero volt reference, as long as the power wires are separated. Safety relays may be used to reliably isolate individual outputs. A common supply will connect isolated outputs together and should be avoided.

Hazardous Area Protection

System installation

The Trusted system modules are not certified for installation in hazardous areas. The system chassis should be fitted in safe areas with temperature and humidity control. Installation in sealed EEx 'd' enclosures is not advisable because:

- No visual front panel health check is possible.
- System maintenance requires access to modules. This requires the enclosure to be opened. This is only possible if the area is made safe which would probably require a site shutdown and purge.
- Ventilation from the enclosure is not possible, and overheating will occur rapidly.

EEx certification

System I/O is not certified for direct connection to hazardous areas. Appropriate zener barriers or I.S. isolators should be fitted on all field loops to hazardous areas. Zener barriers need a reliable intrinsic safety earth with an impedance of less than 0.1 ohms, which should be separate from all other earths.

Non-incendive certification

FTAs T8801 and T8831 may be used for direct connection of inputs from hazardous areas where non-incendive specifications are used (typically in the Americas). Their application is described in the sections above on digital and analogue inputs. Outputs require external power limiting devices.

Lightning Protection

Trusted system modules and FTAs do not provide protection against lightning strike, power surge or severe induced serial noise. The modules include 2.5kV isolation between field circuits and system circuits (and between channels for isolated modules), but this will not protect field circuits against high potentials applied serially across components. Where lightning strikes are common, field wiring should be protected by individual transient voltage surge suppressors which will reduce (but not eliminate) the

AN-T80004 Field Loop Configuration

risk of damage from induced noise. These will still not protect against direct strike, so the site should also have lightning rods fitted to deflect strikes away from plant and field devices.

HART interfacing

None of the Trusted analogue I/O modules will communicate HART protocol. Separate HART multiplexers should be fitted to the loop to communicate with HART devices. These will not affect the current loop operation.

HART is designed for adding digital communications to a simple 4-20mA current loop. A frequency-shift keyed signal is superimposed on the current loop signal at frequencies far higher than the loop's main signal spectrum as shown. These frequencies can be easily filtered, and do not affect the Trusted modules' current loop control or measurement.

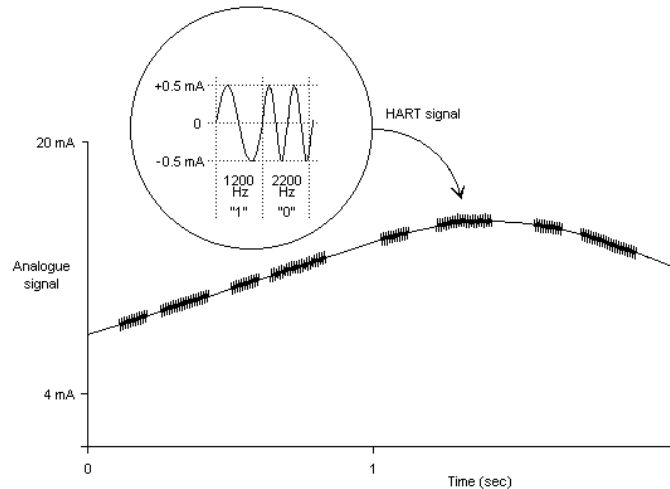

The HART multiplexer should be connected across a loop impedance, so that it is able to drive a signal round the loop. The power supply may be considered as part of the loop, since it appears as a short circuit to the signal.

Some possible connection methods are shown below. The HART multiplexer is shown as a grey box. These permutations are also suitable for isolated analogue inputs; the essential point is that the HART transmitters should see an impedance across their terminals.

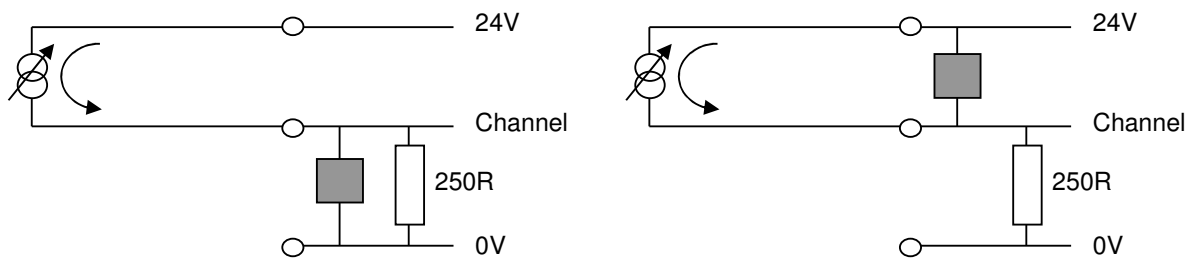

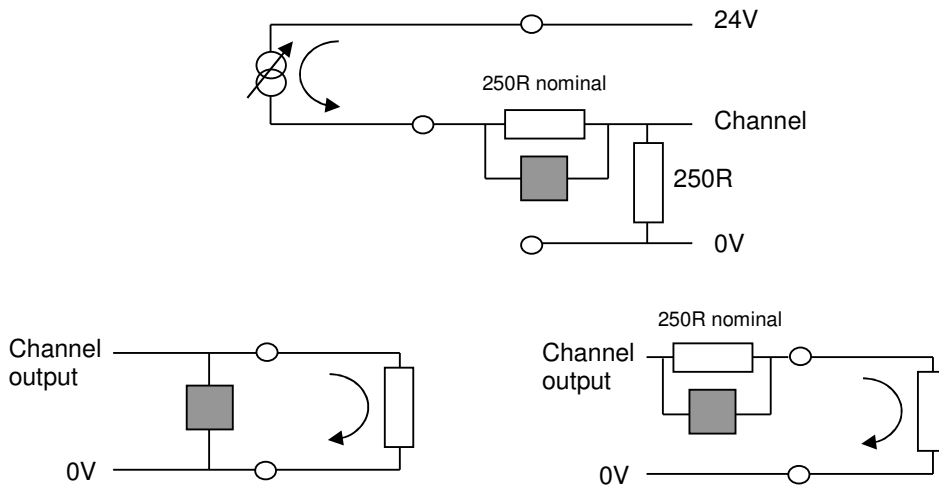

Cable earth and screen wires

At either end of an I/O cable there may be a braid or heavy gauge green or green/yellow cable. This is the protective earth and should be bolted to safety earth. The chassis have a row of threaded holes for terminating these braids.

On some I/O cables there may be a thin green wire. This is a screen earth and should be wired to a separate terminal, connected to a clean reference earth separate from safety earths.

Free Wire Cables

I/O cables without FTA or VFTA plugs are available for most applications and are designed for connection to user-designed terminations (terminal blocks, multicore sockets etc.). These have ident markers on individual cores to show the function of each wire, with the 'CORE' text from the tables below.

The wires are NOT colour coded and core colours will vary between batches or subcontracting manufacturer. The core colours have not been standardised due to regional supply differences. Instead, the idents should be used to distinguish between cores. Some cores have identical functions and are shorted together at both ends (in proper use) as redundant wires. These wires have the same ident and are interchangeable; there is no need to check which module pin is connected to each core.

The wiring tables for each type of free wire cable are shown below for reference.

CONNECTOR 1 (CHASSIS END)				CONNECTOR 1 (CHASSIS END)				CONNECTOR 1 (CHASSIS END)			
CORE	COLOUR	SIZE	PIN	CORE	COLOUR	SIZE	PIN	CORE	COLOUR	SIZE	PIN
		mm ²				mm ²				mm ²	
			a1				b1				c1
-----	-----	-----	a2	-----	-----	-----	b2	-----	-----	-----	c2
CH0		0.5	a3	CH14		0.5	b3	CH28		0.5	c3
-----	-----	-----	a4	-----	-----	-----	b4	-----	-----	-----	c4
CH1		0.5	a5	CH15		0.5	b5	CH29		0.5	c5
-----	-----	-----	a6	-----	-----	-----	b6	-----	-----	-----	c6
CH2		0.5	a7	CH16		0.5	b7	CH30		0.5	c7
-----	-----	-----	a8	-----	-----	-----	b8	-----	-----	-----	c8
0V		0.5	a9	0V		0.5	b9	0V		0.5	c9
CH3		0.5	a10	CH17		0.5	b10	CH31		0.5	c10
-----	-----	-----	a11	-----	-----	-----	b11	-----	-----	-----	c11
CH4		0.5	a12	CH18		0.5	b12	CH32		0.5	c12
-----	-----	-----	a13	-----	-----	-----	b13	-----	-----	-----	c13
CH5		0.5	a14	CH19		0.5	b14	CH33		0.5	c14
-----	-----	-----	a15	-----	-----	-----	b15	-----	-----	-----	c15
CH6		0.5	a16	CH20		0.5	b16	CH34		0.5	c16
-----	-----	-----	a17	-----	-----	-----	b17	-----	-----	-----	c17
CH7		0.5	a18	CH21		0.5	b18	CH35		0.5	c18
-----	-----	-----	a19	-----	-----	-----	b19	-----	-----	-----	c19
0V		0.5	a20	0V		0.5	b20	0V		0.5	c20
CH8		0.5	a21	CH22		0.5	b21	CH36		0.5	c21
-----	-----	-----	a22	-----	-----	-----	b22	-----	-----	-----	c22
CH9		0.5	a23	CH23		0.5	b23	CH37		0.5	c23
-----	-----	-----	a24	-----	-----	-----	b24	-----	-----	-----	c24
CH10		0.5	a25	CH24		0.5	b25	CH38		0.5	c25
-----	-----	-----	a26	-----	-----	-----	b26	-----	-----	-----	c26
CH11		0.5	a27	CH25		0.5	b27	CH39		0.5	c27
-----	-----	-----	a28	-----	-----	-----	b28	-----	-----	-----	c28
CH12		0.5	a29	CH26		0.5	b29	CH40		0.5	c29
-----	-----	-----	a30	-----	-----	-----	b30	-----	-----	-----	c30
CH13		0.5	a31	CH27		0.5	b31	CH41		0.5	c31
-----	-----	-----	a32	-----	-----	-----	b32	-----	-----	-----	c32

TC-202/502/204/504 (40 Channel Input)

Channels 0 and 41 are internal reference channels and should not be connected.

CONNECTOR 1 (CHASSIS END)				CONNECTOR 1 (CHASSIS END)			
CORE	COLOUR	SIZE	PIN	CORE	COLOUR	SIZE	PIN
		mm ²				mm ²	
			a1				c1
-----	-----	-----	a2	-----	-----	-----	c2
CH1		0.5	a3	CH5		0.5	c3
CH2		0.5	a4	CH6		0.5	c4
V FIELD RTNGRP1		0.5	a5	V FIELD RTNGRP1		0.5	c5
CH3		0.5	a6	CH7		0.5	c6
CH4		0.5	a7	CH8		0.5	c7
-----	-----	-----	a8	-----	-----	-----	c8
CH9		0.5	a9	CH13		0.5	c9
CH10		0.5	a10	CH14		0.5	c10
V FIELD RTNGRP2		0.5	a11	V FIELD RTNGRP2		0.5	c11
CH11		0.5	a12	CH15		0.5	c12
CH12		0.5	a13	CH16		0.5	c13
-----	-----	-----	a14	-----	-----	-----	c14
CH17		0.5	a15	CH21		0.5	c15
CH18		0.5	a16	CH22		0.5	c16
V FIELD RTNGRP3		0.5	a17	V FIELD RTNGRP3		0.5	c17
CH19		0.5	a18	CH23		0.5	c18
CH20		0.5	a19	CH24		0.5	c19
-----	-----	-----	a20	-----	-----	-----	c20
CH25		0.5	a21	CH29		0.5	c21
CH26		0.5	a22	CH30		0.5	c22
V FIELD RTNGRP4		0.5	a23	V FIELD RTNGRP4		0.5	c23
CH27		0.5	a24	CH31		0.5	c24
CH28		0.5	a25	CH32		0.5	c25
-----	-----	-----	a26	-----	-----	-----	c26
CH33		0.5	a27	CH37		0.5	c27
CH34		0.5	a28	CH38		0.5	c28
V FIELD RTNGRP5		0.5	a29	V FIELD RTNGRP5		0.5	c29
CH35		0.5	a30	CH39		0.5	c30
CH36		0.5	a31	CH40		0.5	c31
-----	-----	-----	a32	-----	-----	-----	c32

TC-206/506/208/508 (40 Channel Output)

These cables have a short connection at the chassis end for field power supply, designed for a T8290 or T8297 Power Distribution Unit.

151351		
1	V FIELD PG1	2.5mm ² RED
2	V FIELD PG2	2.5mm ² RED
3	V FIELD PG3	2.5mm ² RED
4	V FIELD PG4	2.5mm ² RED
5	V FIELD PG5	2.5mm ² RED

TC-216/516/218/518 (40 Channel Output with Integral Power) Power wires

The integral power cables have the same I/O cores as the TC-206/506/208/508 cables above, but have field power connections wired through to the free end as shown here (one wire for each power group).

CONNECTER 1 (CHASSIS END)	
SIGNAL	PIN
	A1
	A2
CHAN 0 ABC	A3
CHAN 0 ABC	A4
CHAN 1 AB	A5
CHAN 41 C	A6
CHAN 2 AB	A7
CHAN 42 C	A8
0V	A9
CHAN 3 AB	A10
CHAN 43 C	A11
CHAN 4 AB	A12
CHAN 44 C	A13
CHAN 5 AB	A14
CHAN 45 C	A15
CHAN 6 AB	A16
CHAN 46 C	A17
CHAN 7 AB	A18
CHAN 47 C	A19
0V	A20
CHAN 8 AB	A21
CHAN 48 C	A22
CHAN 9 AB	A23
CHAN 49 C	A24
CHAN 10 AB	A25
CHAN 50 C	A26
CHAN 11AB	A27
CHAN 51 C	A28
CHAN 12 AB	A29
CHAN 52 C	A30
CHAN 13 AB	A31
CHAN 53 C	A32

CONNECTER 1 (CHASSIS END)	
SIGNAL	PIN
	B1
	B2
CHAN 14 AB	B3
CHAN 54 C	B4
CHAN 15 AB	B5
CHAN 55 C	B6
CHAN 16 AB	B7
CHAN 56 C	B8
0V	B9
CHAN 17 AB	B10
CHAN 57 C	B11
CHAN 18 AB	B12
CHAN 58 C	B13
CHAN 19 AB	B14
CHAN 59 C	B15
CHAN 20 AB	B16
CHAN 60 C	B17
CHAN 21 BC	B18
CHAN 41 A	B19
0V	B20
CHAN 22 BC	B21
CHAN 42 A	B22
CHAN 23 BC	B23
CHAN 43 A	B24
CHAN 24 BC	B25
CHAN 44 A	B26
CHAN 25 BC	B27
CHAN 45 A	B28
CHAN 26 BC	B29
CHAN 46 A	B30
CHAN 27 BC	B31
CHAN 47 A	B32

CONNECTER 1 (CHASSIS END)	
SIGNAL	PIN
	C1
	C2
CHAN 28 BC	C3
CHAN 48 A	C4
CHAN 29 BC	C5
CHAN 49 A	C6
CHAN 30 BC	C7
CHAN 50 A	C8
0V	C9
CHAN 31 BC	C10
CHAN 51 A	C11
CHAN 32 BC	C12
CHAN 52 A	C13
CHAN 33 BC	C14
CHAN 53 A	C15
CHAN 34 BC	C16
CHAN 54 A	C17
CHAN 35 BC	C18
CHAN 55 A	C19
0V	C20
CHAN 36 BC	C21
CHAN 56 A	C22
CHAN 37 BC	C23
CHAN 57 A	C24
CHAN 38 BC	C25
CHAN 58 A	C26
CHAN 39 BC	C27
CHAN 59 A	C28
CHAN 40 BC	C29
CHAN 60 A	C30
CHAN 61 ABC	C31
CHAN 61 ABC	C32

TC-602/702/604/704 (60 Channel Input)

These cables are idented CH0 to CH61 with six (interconnected) 0V wires. Channels 41 to 60 are connected to two separate pins on the module socket as listed in the table above. This is because the 60 channel modules use a similar field PCB to the 40 channel modules but distribute two circuits to each channel instead of three. Channels 0 and 61 are internal reference channels and should not be connected.

