

# Installation and User Guide

## Pellicon® 3 Cassettes

### Contents

Introduction.....	2
Membrane Type .....	2
Pump Capacity .....	2
Water Quality .....	2
Installation .....	2
Pellicon® 3 88 cm <sup>2</sup> and 0.11 m <sup>2</sup> Cassette Holder Installation.....	2
Pellicon® 3 0.57 or 1.14 m <sup>2</sup> Cassette Benchtop Holder Installation.....	3
Manual Process-Scale Holder Installation .....	4
Hydraulic Process Scale Holder Installation .....	5
Maintenance .....	7
Flushing and Cleaning .....	7
Flushing .....	8
Cleaning .....	8
Sanitization .....	10
Depyrogenation.....	10
Integrity Testing.....	11
Measurement of Normalized Water Permeability .....	11
Storage.....	13
Troubleshooting.....	14
Warranty .....	15

## Introduction

This guide provides installation and maintenance procedures for Pellicon® 3 cassettes. It is not intended to provide validation protocols or supporting data for validation purposes. Please refer to the cassette Validation Guide for this information. Please refer to the Certificate of Quality supplied with each cassette for specifications.

### Membrane Type

Install filters containing only one type of membrane in the filter holder at one time. Do not mix filters with different pore sizes or nominal molecular weight cutoffs. The area of membrane used depends on the filter surface area required for your particular application.

### Pump Capacity

When operating Pellicon® 3 cassettes, select a pump with adequate capacity. Recommended feed flow rate for cassettes is 4 - 6 liter/min/m<sup>2</sup>. Optimal cross flow will depend on the actual solution being filtered.

#### NOTE

Running at sub-optimal feed fluxes can result in poor mass transfer, and larger membrane area requirements. Higher feed fluxes can lead to device and/or system pressure limitations, and require larger pump and pipe diameters. Recommendations are based upon achieving optimal system performance.

### Water Quality

Reverse osmosis (RO) water or water for injection (WFI) is recommended.

## Installation

### Pellicon® 3 88 cm<sup>2</sup> and 0.11 m<sup>2</sup> Cassette Holder Installation

#### NOTE

Pellicon® 3 88 cm<sup>2</sup> and 0.11 m<sup>2</sup> Cassettes must be installed in a Pellicon® Cassette Holder, Catalog Number XX42PMINI.

#### Holder Installation

1. Loosen the nuts on the tie rods of the holder and remove the nuts, washers, tie rod spacers and end plate.
2. Inspect the tie rods and nuts for signs of burrs or stripped threads. Replace any damaged components. Nuts must turn freely on the tie rods to ensure proper tightening of the holder.
3. Slide the Pellicon® 3 Cassette onto the holder so that the tie rods pass through the cutouts in the Pellicon® 3 Cassette. Repeat to install one or two additional Pellicon® 3 Cassettes if required.
4. Slide the end plate onto the tie rods and press the end plate against the cassette.
5. Install the tie rod spacers, washers and nuts. Hand-tighten the nuts, alternating from one nut to the other nut.

#### NOTE

Uneven tightening of the nuts can damage the Pellicon® 3 Cassette. Nonparallel plates or compression of the filters at one end can cause leakage.

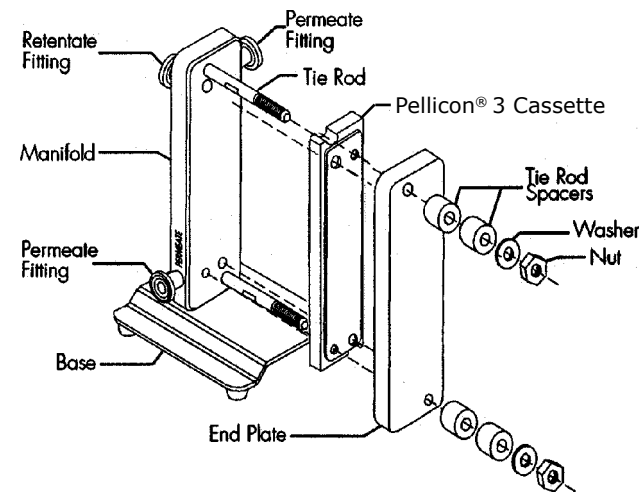

*Pellicon® Cassette Holder, XX42PMINI*

6. Tighten the nuts using the torque wrench and  $\frac{9}{16}$  in. socket supplied with the Pellicon® Cassette Holder. If your wrench has a ratchet style head, move the lever to the right lock position to tighten the nuts or to the left lock position to loosen the nuts.
7. Set the torque wrench at 180 to 200 in. lb. (20.3 to 22.6 Nm) by holding the spring loaded lock collar down and turning the handle until the 180 to 200 in. lb. (20.3 to 22.6 Nm) mark aligns with the 0 (zero) mark on the collar.
8. Rotate the handle slightly to spring the lock collar back into place.
9. Attach the socket to the torque wrench by firmly pressing the socket onto the torque wrench drive.
10. Place the socket over one nut. With a continuous motion, turn each nut  $\frac{1}{4}$  turn, alternating between the nuts, until the wrench clicks, which will indicate it has reached the set force.

## Pellicon® 3 0.57 or 1.14 m<sup>2</sup> Cassette Benchtop Holder Installation

XX42P0060 Pellicon® Cassette Acrylic Filter Holder  
XX42PRV60 Pellicon® Cassette Acrylic Holder Low Retentate Volume  
XX42P0080 Pellicon® Cassette Stainless Steel Holder  
XX42P0K80 Pellicon® Cassette Stainless Steel Holder Assembly

1. Loosen the nuts on the tie rods of the holder and remove the nuts, washers and end plate.
2. Inspect the tie rods and nuts for signs of burrs or stripped threads. Replace any damaged components. Nuts must turn freely on the tie rods to ensure proper tightening of the holder.
3. Clean the manifold adapter plate (XXPEL3MAP) with an alcohol wipe.
4. Slide the manifold adapter plate onto the holder against the holder's manifold plate, with the solid light grey side labeled "Manifold Side" towards the manifold, and the wings resting on the tie rods. Slide the manifold adapter plate directly up against the stainless steel manifold.
5. Slide the Pellicon® 3 cassette up against the manifold adapter plate. The dark grey center with light grey perimeter of the manifold adapter plate should be up against the Pellicon® 3 cassette.
6. Slide additional Pellicon® 3 Cassettes onto the holder if more membrane area is required.
7. Slide the end plate with the handle side up onto the tie rods.
8. Tie rod spacers (XX4200066) are available when operating the system with low membrane area. Place enough spacers on each rod so that the length of exposed threaded tie rod is less than the length of the hex socket. Replace the washers and nuts. Hand tighten the nuts in a diagonal pattern.

### NOTE

Uneven tightening of the nuts can damage the Pellicon® Cassette. Nonparallel plates or compression of the filters at one end can cause leakage.

9. Tighten the nuts using the torque wrench and  $\frac{15}{16}$  in. deep hex socket supplied with the Pellicon® Cassette Holder.
10. Set the torque wrench by turning the knurled locking collar clockwise or by pulling the handle out to unlock. Turn the torque setting scale clockwise until the 350 in-lb (40 Nm) mark on the torque scale is opposite the zero mark on the smooth collar. Turn the knurled locking collar counterclockwise to lock.

11. Using the torque wrench and  $15/16$  in. deep hex socket, turn each nut  $1/8$  turn in the sequence shown here. When the wrench clicks, this indicates that the set force has been reached. **DO NOT OVER TORQUE.** Evenness of torque is critical to system performance.

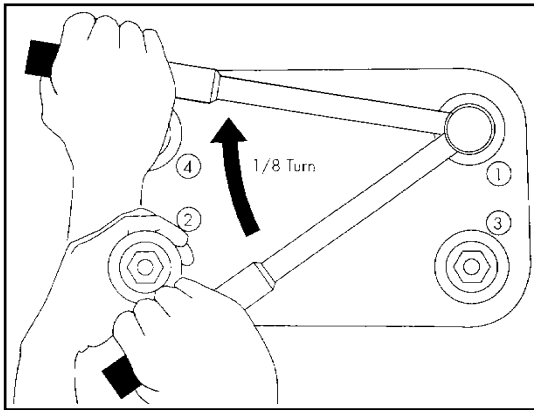

*Pellicon® Holder Tightening Sequence*

**NOTE** Pellicon® 2 and Pellicon® 3 cassettes require 46 kN of axial compressive force to function correctly. If installing in a holder from any other supplier than MilliporeSigma please contact your local Technical Service team for guidance on the appropriate torque settings.

**NOTE** Depending on the results of the Integrity Test, the torque may need to be increased at intervals of 50 in-lb (5.6 Nm) up to a maximum of 550 in-lb (62 Nm).

12. Recheck the torque prior to use.

**NOTE** If the filter holder is tightened in a cold area and moved to a warmer area, loosen the nuts entirely, let the filter holder warm up, and then retighten to allow for thermal expansion of the end plates and cassettes.

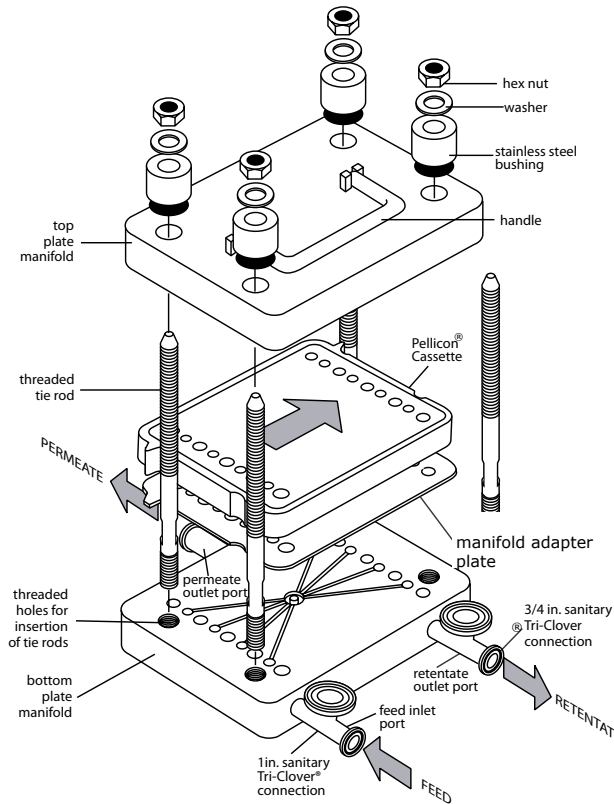

*Exploded View of Stainless Steel Pellicon® Cassette Filter Holder.*

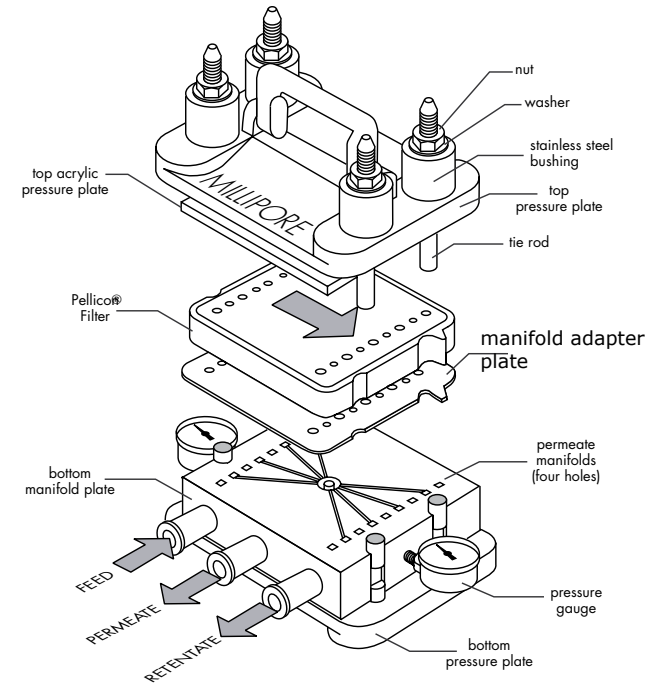

*Exploded View of Acrylic Pellicon® Cassette Filter Holder.*

## Manual Process-Scale Holder Installation

1. Loosen the nuts on the tie rods of the holder and remove the nuts, washers and end plate.
2. Inspect the tie rods and nuts for signs of burrs or stripped threads. Replace any damaged components. Nuts must turn freely on the tie rods to ensure proper tightening of the holder.
3. Clean the manifold adapter plate (XXPEL3MAP) with an alcohol wipe.
4. Slide the manifold adapter plate onto the holder against the holder's manifold plate, with the solid light grey side labeled "Manifold Side" towards the manifold, and the wings resting on the tie rods. Slide the manifold adapter plate directly up against the stainless steel manifold.

- Slide the Pellicon® 3 cassette up against the manifold adapter plate. The dark grey center with light grey perimeter of the manifold adapter plate should be up against the Pellicon® 3 cassette. Slide additional cassettes into the holder against each other if more membrane area is required.
- Replace the spacers, washers and nuts as shown in Figure 5. Hand-tighten the nuts in a diagonal fashion (see Figure 4). Use a few drops of suitable lubricant on the tie-rods and between the nuts and the washers if required.

**NOTE**

Uneven tightening of the nuts can damage the Pellicon® 3 Cassette. Nonparallel plates or compression of the filters at one end can cause leakage.

- Tighten the nuts using the torque wrench and  $15/16$  in. deep hex socket supplied with the Pellicon® 3 Cassette Holder.
- Set the torque wrench by turning the knurled locking collar clockwise or by pulling the handle out to unlock. Turn the torque setting scale clockwise until the 350 in-lb (40 Nm) mark on the torque scale is opposite the zero mark on the smooth collar. Turn the knurled locking collar counterclockwise to lock.
- Using the torque wrench and  $15/16$  in. deep hex socket, turn each nut  $1/8$  turn in the sequence shown in Figure 4. When the wrench clicks, this indicates that the set force has been reached. **DO NOT OVER TORQUE.** Evenness of torque is critical to system performance.

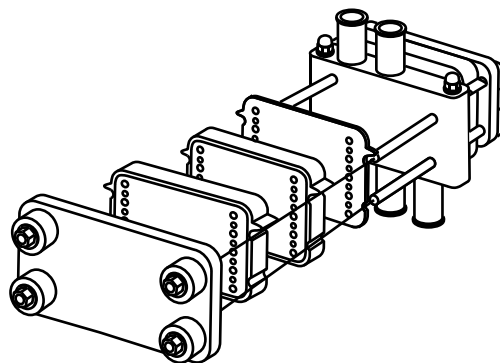

*Process Scale Holder*

**NOTE**

Depending on the results of the Integrity Test, the torque may need to be increased at intervals of 50 in-lb (5.6 Nm) up to a maximum of 550 in-lb (62 Nm).

- Recheck the torque prior to use.

## Hydraulic Process Scale Holder Installation

The Hydraulic Closure with Manual Controls is intended for use with the Millipore Process Scale Filter Holder. It will maintain appropriate compression on the cassettes during processing or during storage of installed filter cassettes.

RUN mode is required for process operations, including flushing and cleaning. The system hydraulic pressure is maintained at 1950 psig  $\pm$  100 psig.

In STORE mode, the system may be stored with the Pellicon® 3 cassettes installed. The system hydraulic pressure is maintained at 1200 psig  $\pm$  100 psig.

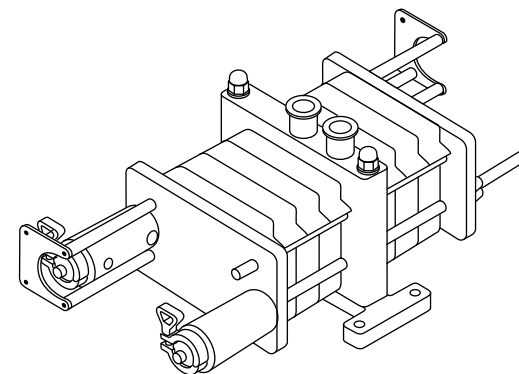

*Hydraulic Process Scale Holder*

- Set the System Mode switch to DUMP.

**NOTE**

Check the Hydraulic Pressure Gauge on the hydraulic power unit panel to be sure the pressure is relieved. Do not proceed until the hydraulic pressure reaches 0 psig as read on gauge PI-2.

2. On the first holder level (if there are more than one), remove the TC clamps and inserts holding the hydraulic cylinders to the clamp rods.
3. Loosen and remove the hand wheels on the clamp rods at the opposite end plate (of the same holder level).
4. Slide the end plate away from the manifold segment, creating an opening for cassette insertion into the holder.
5. Slide the manifold adapter plate or a stainless steel support plate onto the holder against the holder's manifold plate.
6. Slide a Pellicon® 3 Cassette onto the holder. Up to ten 1.14 m<sup>2</sup> cassettes may be installed per side if required.
7. Slide the end plate back against the cassette assembly.
8. Install the grooved clamp rods, TC clamps, inserts and hand wheels.

**NOTE**

The hand wheels require hand tightening only. Ensure that each end plate is flush against the cassette assembly and both hand wheels are snug against the end plate. No less than one inch of excess thread on the clamp rod exiting the hand wheel should be exposed.

9. Repeat the procedure for any other holder levels.

**Holder Pressurization and Operation**

1. The hydraulic fluid reservoir must be full (indicated on the level indicator inside the Hydraulic Power Unit).
2. All hydraulic flex hose connections must be installed from the Hydraulic Power Unit to the hydraulic cylinders.
3. All hardware on the clamp rods must be in place. Tighten the hand wheels until they are hand-tight.
4. Turn on the air supply to the Hydraulic Power Unit. A minimum of 80 psig air pressure should be available. Check the air pressure on the pressure gauge PI-1 on Hydraulic Power Unit front panel.
5. The Power Switch on the Hydraulic Control Unit HS-1 must be in the ON position, and the green Power Indicator must be illuminated.
6. Set the Operating Mode Selector Switch, HS-3 to RUN or STORE, as required.
7. Set the System Mode Selector Switch, HS-2 to ENABLE. The hydraulic closure system will close the holder assembly and maintain the appropriate pressure on the holder for either RUN or STORE mode, as selected.

8. To relieve hydraulic system pressure at any time, set the System Mode Selector Switch to DUMP or open the System Pressure Manual Dump Valve, MV-1 on the left side of the Hydraulic Power Unit.

**NOTE**

When the cassettes are compressed for the first time, reduction of excess space between the cassettes can result in significant movement of the hydraulic piston. In some cases, the entire functional length of the piston (approximately 2 inches/5 cm) may be extended. If this happens, the piston will be exerting force against the hydraulic cylinder instead of against the cassettes and the cassettes will not be properly compressed. To achieve correct cassette compression, relieve the hydraulic system pressure by setting the System Mode Selector Switch to DUMP, manually tighten the hand wheels again, and then re-set the Selector Switch to RUN or STORE. This process may need to be repeated 1 or 2 times over the first 10-15 minutes of compression to ensure the hydraulic piston remains within its functional position during processing.



**Caution**

The hydraulic closure system must remain connected to the holder during processing and during storage of installed cassettes. The hydraulic closure system must be depressurized before connecting or disconnecting fittings. If the position of the Operating Mode Selector Switch (RUN or STORE) is changed while the system is in ENABLE mode, the hydraulic system pressure will drop to 1000 psig and then increase to the correct pressure for the new selected mode. If the hydraulic system pressure drops below 1200 psig while in RUN mode or 800 psig while in STORE mode, the relevant Low Pressure Alarms (PAL-1 or PAL-2 respectively) will be illuminated and the Alarm Horn will sound. Once the problem has been corrected and hydraulic pressure restored, the alarm condition may be cleared by pressing the Alarm Reset – Resume Operation Push-button.

**Maintenance**

Pellicon® 3 Cassettes must be operated while under compression from the holder assembly to ensure that the cassettes will seal properly. The compression is supplied by applying torque to the nuts on the threaded tie-rods of the holder assembly. If proper holder maintenance is not performed, higher torque values will be required to achieve proper sealing.

The following steps are recommended to keep the holders in operational condition:

1. Clean nuts, washers and tie-rods before every use to ensure that they are free of particles. A mild solvent such as IPA and water is generally effective.
2. Use a few drops of suitable lubricant on the tie-rods and between the nuts and the washers, whenever permitted. This could be a food grade vegetable oil or glycerin.
3. Check with your Quality Assurance department before introducing a new lubricant into your production facility.
4. Protect the tie-rods from receiving any blows that could damage their threads, which can lead to galling. Particular care should be taken when using a torque wrench near the tie-rods.
5. Replace any component that is visibly worn or does not spin freely.
6. Rates of wear will vary from system to system, but replacement of nuts and washers should be considered after every ten installations, to maintain high sealing force in the holder.
7. When new nuts do not spin freely, refurbish the threaded rods with a  $\frac{5}{8}$  in-18 die.
8. It is recommended that a set of spare parts be kept on hand at all times.

**Flushing and Cleaning**

Flushing and cleaning are required for following process steps:

**Storage Solution Removal**

Pre-use flushing and cleaning steps are performed to remove shipping solution. A minimum of 60 liters of solution per m<sup>2</sup> of membrane should be used in a combination of flushes and recirculation cleanings.

**Preprocess Equilibration**

A flushing step is utilized to ensure that the system and cassettes are properly prepared for processing. The flushing solution may be something other than water depending upon the initial solution used for the process.

**Post Process Cleaning**

Cleaning and flushing steps are performed after product recovery and are intended to clean and sanitize the system and restore clean water permeability and process flux to within range. Some applications may require a two-step cleaning procedure. In these cases it is imperative that the primary cleaning agent be flushed completely from the system to avoid potentially harmful chemical reactions between cleaning agents. A full cleaning recipe encompasses a sequence of flushes and recirculations to achieve regeneration of the membrane performance, sanitization,

depyrogenation and residual flush out from the system. To select a cleaning method, identify your application or suspected foulant from the Cleaning Agent Selection Chart. Select the cleaning agent or agents compatible with your membrane type and application requirements. Sanitization, depyrogenation and storage agents are chosen similarly. In many instances, sanitization and depyrogenation may be accomplished in the same step.

With consumable agents such as chlorine, monitor the concentration of the agent over the course of the cleaning cycle and add additional cleaning agent as needed to maintain the recommended concentration.

### Suggested Retentate Pressures for Flushing and Cleaning

Membrane Cutoff	Retentate Pressure bar (psi)
3, 5 kD	2.8 - 3.4 (40 - 50)
10, 30, 50 kD	0.5 - 1.0 (5.0 - 15)

Suggested retentate pressures are recommended to achieve desired feed flow to permeate flow conversion rate. Conversion rate of approximately 30% is desired for 10, 30 and 50 kD devices and conversion rate of at least 10% and up to 30% is desired for 3 and 5 kD devices.

## Flushing

The flushing step removes residuals from the cassette and the system piping. Flushing is done primarily with clean water but may be performed with cleaning or buffer solutions. The typical volume of flushing solution for this step is 20 L/m<sup>2</sup> of membrane area.

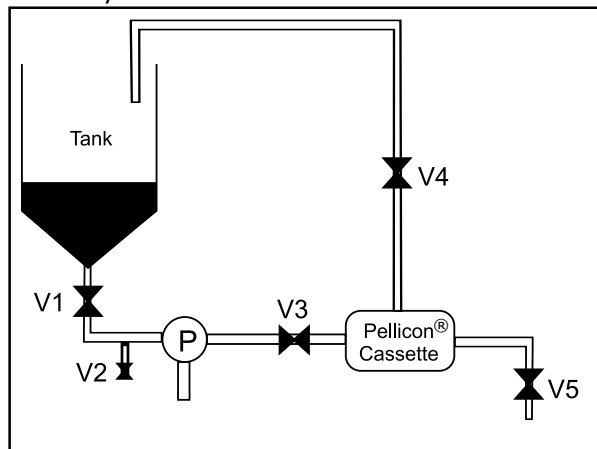

Typical System Setup

1. Close the tank outlet valve (V1) and the tank drain valve (V2).
2. Fill the tank with the flushing solution.
3. Fully open the retentate valve (V4) (and permeate valve (V5) if present) and direct both the retentate and permeate to drain.
4. Open the tank outlet valve (V1).
5. Turn on the feed pump and pump water into the feed port of the Pellicon® Holder. The recommended feed flow rate is 4 to 6 Lpm/m<sup>2</sup>.

6. Once the pump has slowly ramped up to the set point, partially close the retentate valve (V4) to achieve the retentate pressure listed above.
7. Flush the filter(s) until a total of 20 liters of water per m<sup>2</sup> of installed filter area has been pumped through the system to drain. Depending on individual removal criteria, the total flush volume can be adjusted.
8. At the end of the flush, turn off the feed pump, fully open retentate and filtrate lines and drain the retentate and filtrate piping.

## Cleaning

The cleaning step applies to installations where all parts of the system will be exposed for a period of time to the process fluids. Membrane regeneration, system sanitization, depyrogenation and system storage require a cleaning step. The typical volume of cleaning solution for this step is approximately 10 to 20 L/m<sup>2</sup> of membrane area.

1. Close the tank outlet valve (V1) and drain valve (V2).
2. Fill the tank with the cleaning solution. (Cleaning solution selection is noted in the Cleaning Selection Chart.)
3. Fully open the retentate valve (V4) (and permeate valve (V5) if present) and direct both the retentate and filtrate to the tank.
4. Open the tank outlet valve (V1).



5. Turn on the feed pump and pump water into the feed port of the Pellicon® holder. The recommended feed flow rate is 4 to 6 L/min/m<sup>2</sup>.
6. Once the pump has slowly ramped up to the set point, partially close the retentate valve (V4) to achieve the retentate pressure listed in the table above.
7. Recirculate the cleaning solution for the prescribed time period as noted in the Cleaning Conditions Chart.

**NOTE**

If the system is complex and has other associated manifolds, ensure that all wetted surfaces in the manifolds are exposed to the cleaning solution. All valves that have been exposed to process fluids should also be exposed to the cleaning solution. It is good practice to cycle (partially open and the partially close) valves at least twice over the course of the cleaning cycle to ensure that all wetted internal surfaces of the valve body are exposed to the cleaning solution.

8. At the end of the cleaning recirculation, direct the retentate and permeate to drain and continue to run until the tank is empty (without running the pump dry), then turn off the feed pump, fully open the retentate and filtrate lines and drain the retentate and filtrate (permeate) piping.
9. Repeat the flushing procedure after cleaning to remove chemical residue from the cassette and system piping.

### Primary Cleaning Agents and Conditions for Organics, Biofilms, Biopolymer, Proteins and Polyphenolic

Membrane	Cleaning Agent	Concentration	Temp (°C)	pH	Time (min)
Biomax®	NaOH	0.1 N - 1.0 N	25 - 50	13 - 13.7	30 - 60
	NaOCl	200 - 500 ppm	25 - 50	10 - 11	30 - 60
Ultracel®	NaOH	0.1 N - 0.5 N	25 - 50	13 - 13.7	30 - 60

Stable NWP from run to run is achievable after initial exposure. There is an initial NWP decline in Pellicon® 3 Cassettes after initial exposure to 0.5 N NaOH for Ultracel® and 1.0 N NaOH for Biomax®. Better membrane life has been observed at lower concentrations. At the higher concentrations, total exposure time of Pellicon® 3 Cassettes with Ultracel® membrane must not exceed 100 hours and total exposure time of Pellicon® 3 Cassettes with Biomax® membrane must not exceed 200 hours. Contact Technical Service for additional Cleaning Agents and Conditions.

## Sanitization

Sanitization to reduce bioburden should be performed after the Pellicon® 3 Cassette installation has been thoroughly cleaned and flushed. Sanitization pressures, flow rates and volumes are identical to those used during Cleaning. Repeat the flushing procedure after sanitization to remove chemical residue from the cassette and system piping.

### NOTE

Use sanitization agents and conditions that are suitable for the process requirements. Sanitization agents must comply with applicable local regulations.

### Recommended Sanitization Conditions and Agents

Membrane	Sanitizing Agent	Concentration	Temp (°C)	pH	Time (min)
Biomax®	NaOCl	200 - 500 ppm	25 - 50	10 - 11	30
	Peracetic acid-containing Cold Sanitant*	1%	10 - 40	3.5	30
	NaOH	0.1 N - 1.0 N	25 - 50	13-13.7	30
Ultracel®	Peracetic acid-containing Cold Sanitant*	1%	10 - 40	3.5	30
	NaOH**	0.1 N	25 - 50	13	30

\* Typical Peracetic acid-containing cold sanitant contain 20-24% Hydrogen Peroxide, 4.6% Peracetic acid, and 8-10% Acetic acid.

\*\* Use milder conditions if effectiveness of agent is still observed. Better membrane life is expected with lower concentration of caustic and/or at 20-25°C for regenerated cellulose membranes with a nominal molecular weight limit of 3 or 5 kDa.

## Depyrogenation

If depyrogenation is required, it should only be performed after the system has been cleaned, sanitized, and flushed. Depyrogenation pressures, flow rates and volumes are identical to those used during Cleaning. Water for injection should be used during depyrogenation.

### Depyrogenation Conditions and Agents

Membrane	Depyrogenation Agent	Concentration	Temp (°C)	pH	Time (min)
Biomax®	Phosphoric Acid	0.1 M	30 - 50	1	30
	NaOH	0.1 N	25 - 50	13	30
Ultracel®	NaOH*	0.1 N	25 - 50	13	30

\*Use milder conditions if effectiveness of agent is still observed. Better membrane life is expected with lower concentration of caustic and/or at 20-25°C for regenerated cellulose membranes with a nominal molecular weight limit of 3 or 5 kDa.

## Integrity Testing

Pellicon® 3 filter integrity should be tested on a cleaned and thoroughly flushed system. The presence of residual cleaning agents can significantly alter integrity test results. Integrity testing should be performed on a water wet membrane only.

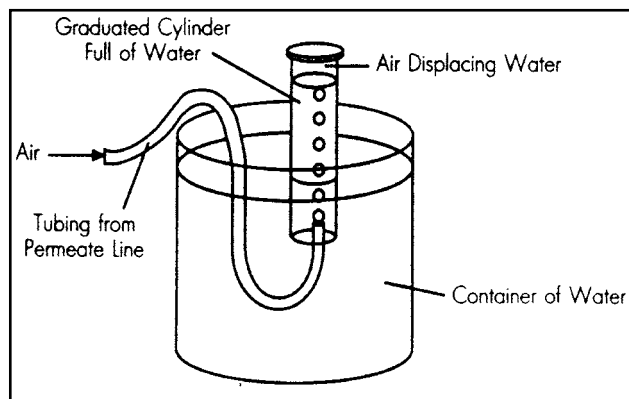

*Integrity Test setup*

1. Drain the system of water. Drain the retentate side of the system as thoroughly as possible.
2. Attach a regulated and filtered air supply to the feed or retentate piping, preferably at the high point of the system.
3. Isolate either the feed or the retentate piping by closing a valve or capping the piping if there is no valve on it (to enable pressurization of the filter feed channels).
4. Open the permeate line.

5. Slowly raise the air pressure to the recommended test value and wait at least 5 minutes to purge residual water in the permeate line. Permeate line must be completely emptied before measuring air flow. Do not exceed the recommended air pressure as this may displace water from the membrane pores and result in excessively high air flow (a false failure). Rewet the membrane if this occurs.
6. After the diffusion air flow pressure stabilizes, measure and record the air pressure, temperature and the air flow rate exiting the permeate line. The air flow rate may be measured with an air flow meter or by measuring the air displaced into a submerged and inverted volumetric cylinder as shown in the figure above.
7. Compare the measured air flow rate to the specified flow value on the Certificate of Quality included with the cassette. If the measured flow rate exceeds the specified flow value, refer to the Troubleshooting section of this guide.

## Measurement of Normalized Water Permeability

The normalized water permeability (NWP) for Pellicon® 3 Cassettes should be established prior to the first product contact of each filter. New membranes should be cleaned, flushed and integrity tested before measuring NWP. The NWP measured at this point is used as a benchmark against subsequent NWP measurements to determine cleaning efficacy.

1. Close the tank outlet valve.
2. Fill the tank with filtered, deionized water, water for injection, or reverse osmosis permeate. The flush water must be extremely pure to avoid fouling the membranes or introducing other contaminants into the system. The NWP may be measured with solutions other than water (i.e. storage solution or buffer) as long as the same conditions and solution are used for each subsequent measurement.
3. Fully open the retentate (and permeate valve if present) and direct both the retentate and permeate lines back to the tank.
4. Open the tank outlet valve.

5. Turn on the feed pump and pump water into the feed port of the Pellicon® holder. The recommended feed flow rate for Pellicon® A, C or D screens is 4 to 6 L/min/m<sup>2</sup>. (The same conditions MUST be used each time NWP is measured in order to ensure accuracy.)
6. Recirculate the water for 10 minutes. Ensure that the pressure and the temperature conditions are stable.
7. Record the feed and permeate flow rate, feed, retentate, and permeate pressures, and the temperature of the water.
8. At the end of the recirculation, fully open the retentate and filtrate lines, turn off the feed pump, and drain the retentate and filtrate piping.

Calculate the NWP:

$$\text{NWP} = R * F / (A * [(P_{in} + P_{out})/2 - P_p])$$

These units yield

LMH/bar [liters/(m<sup>2</sup> •hours•bar)]

Calculate:

R = Permeate Flow Rate in L/hour

P<sub>in</sub> = Feed Pressure in bar

P<sub>out</sub> = Retentate Pressure in bar

T = Water Temperatures in °C

P<sub>p</sub> = Permeate Pressure (if non-zero) in bar

A = Total Filter area in m<sup>2</sup>

F = Temperature correction factor from table

The acceptance criterion for cleaning efficacy as measured by NWP is membrane and application specific, and may vary between plants. Key importance is stable process flux and no carry over.

If the NWP decreases significantly from run-to-run, cleaning procedures may be inadequate. Alternative cleaning agents and procedures should be investigated. Contact a Technical Service Representative for assistance.

### NWP Temperature Correction Factor (F)\*

T (°F)	T (°C)	F	T (°F)	T (°C)	F	T (°F)	T (°C)	F
125.6	52	0.595	96.8	36	0.793	68.0	20	1.125
123.8	51	0.605	95.0	35	0.808	66.2	19	1.152
122.0	50	0.615	93.2	34	0.825	64.4	18	1.181
120.2	49	0.625	91.4	33	0.842	62.6	17	1.212
118.4	48	0.636	89.6	32	0.859	60.8	16	1.243
116.6	47	0.647	87.8	31	0.877	59.0	15	1.276
114.8	46	0.658	86.0	30	0.896	57.2	14	1.310
113.0	45	0.670	84.2	29	0.915	55.4	13	1.346
111.2	44	0.682	82.4	28	0.935	53.6	12	1.383
109.4	43	0.694	80.6	27	0.956	51.8	11	1.422
107.6	42	0.707	78.8	26	0.978	50.0	10	1.463
105.8	41	0.720	77.0	25	1.000	48.2	9	1.506
104.0	40	0.734	75.2	24	1.023	46.4	8	1.551
102.2	39	0.748	73.4	23	1.047	44.6	7	1.598
100.4	38	0.762	71.6	22	1.072	42.8	6	1.648
98.6	37	0.777	69.8	21	1.098	41.0	5	1.699

\*Based on Water Fluidity Relative to 25°C (77°F) Fluidity Value  $F = (\mu_T / \mu_{25})$  or  $(\mu_T / \mu_{77})$

## Storage

Storage solution must be introduced into the system through the cassettes and the system piping to put the system in a bacteriostatic state in between process runs. This procedure requires a minimum of 10 L/m<sup>2</sup> of solution. Refer to [Typical System Setup](#) diagram.

1. Close the tank outlet valve (V1) and drain valve (V2).
2. Fill the tank with the storage solution.
3. Fully open the retentate valve (V4) (and permeate valve (V5) if present) and direct both the retentate and filtrate to the tank.
4. Open the tank outlet valve (V1).
5. Turn on the feed pump and pump water into the feed port of the Pellicon® holder. The recommended feed flow rate for Pellicon® 3 cassettes is 4 to 6 L/min/m<sup>2</sup>.
6. Once the pump has slowly ramped up to the set point, partially close the retentate valve (V4) to achieve the retentate pressure listed [here](#).
7. Recirculate the storage solution for 5 to 10 minutes.

### NOTE

If the system is complex and has other associated manifolds, ensure that all wetted surfaces in the manifolds are exposed to the solution. All valves that have been exposed to process fluids should also be exposed. It is good practice to cycle (partially open and the partially close) valves at least twice over the course of the cycle to ensure that all wetted internal surfaces of the valve body are exposed to the solution.

8. Filters may be stored in holders with the feed, retentate and filtrate isolation valves closed and enough compression on the cassettes to ensure that the storage fluid cannot escape or evaporate.
9. The filters may also be removed from the system and placed in sealed bags or containers. Submerge in storage

solution in appropriate container. Filters should be kept at 2-8°C when removed from the holder. Process holders with hydraulics can properly hold and maintain storage solution. Process holders are also designed with a store mode compression setting that releases to about 60% of the process compression and ensures that the units will not leak externally.

### NOTE

The storage agent used must comply with applicable local regulations.

## Recommended Storage Solutions for Pellicon® 3 Cassette Filters

Membrane	Storage Agent	Concentration	pH	Recommended Time Period
Ultracel®	NaOH*	0.05 N	12.7	1 year
	NaOH	0.1 N	13	6 months
Biomax®	Acetic/ Phosphoric Acid	0.16 M Acetic/0.12 M Phosphoric Acid	2 - 3	1 year
	NaOH	0.1 N	13	1 year

\*Use milder conditions if effectiveness of agent is still observed. Better membrane life is expected with lower concentration of caustic and/or at 20-25°C for regenerated cellulose membranes with a nominal molecular weight limit of 3 or 5 kDa.

These recommended storage agents will ensure membranes remain wet and will prevent microbiological growth without damage to the filter. Upon reinstallation, the filters should be flushed, cleaned and sanitized prior to use.

Filters should not be frozen. Fresh solutions should be prepared after the recommended time period to prevent possible microbial growth or contamination.

Ultracel® membranes can be stored in 0.1 N NaOH only for the recommended time period. Longer exposure may result in membrane damage.



## Troubleshooting

Symptom	Possible Cause	Remedy
Integrity test failure or low retention	Areas of membrane incompletely wetted	Repeat Flushing Procedure. Flush with water, retest
	Manifold adapter plate not installed	Install manifold adapter plate
	Inadequate pump capacity	Use larger pump when wetting filters
	Compression of filter stack inadequate	Inspect threads, nuts and tie rods and system compression. Torque unit again; retest. Increase torque if necessary.
	Temperature change since last time holder was torqued	Torque unit again; retest
	Chemical compatibility problem	Review chemical compatibility of filter. Replace filter.
	Damage to membrane or cassette	Visually inspect filter, replace as needed
	Improper membrane selection	Contact Technical Service.
Low NWP Value	System not vented properly	Ensure system is vented so that air is removed.
	System and cassette not completely flushed	Flush system and cassette.
	System and cassette not completely cleaned	Clean system and cassette.

Symptom	Possible Cause	Remedy
High NWP	Damage to membrane or cassette	Integrity test cassette
	System and cassette over pressurized	Reduce system pressure
	Worn cassette	Replace cassette
Multiple leaks in filter stack	Improper torque or compressive force	Check torque procedure, retorque. Check for dirt or corrosion on tie rods or bolts
Tube fitting leaks	Tube/fitting cracked	Inspect, replace part
	NPT fitting not wrapped	Remove old tape, re-tape adequately with PTFE tape
	End of tubing not cut squarely	Cut tube square and reinstall
	Missing O-ring or ferrule on fittings of defective sanitary gasket	Replace missing component, gasket, or entire fitting
	Loose clamp	Tighten clamp
	Oversized clamp	Replace clamp with smaller diameter clamp
	Leak between holder, filters	Dirt or debris in filter
Immediate complete pressure loss	Compression force too low	Check torque and compressive force
	Tube or fitting leaks	See remedy under Tube/Fitting Leaks above

Symptom	Possible Cause	Remedy
Bubbling at external surface of filter stack	Dirt, debris or loose holder, or chemical incompatibility	See remedy under Leak Between Filters above.
Foaming in system	Fitting leak	See remedy under Tubing/Fitting Leaks
	Loose holder	Retighten holder
	Improper flush out of chemical	Flush with additional water
	Feed line sucking air	Make sure feed line is fixed below fluid/air interface
	Vortex in feed container	Add baffle to break vortex or reduce mixing speed
	Retentate splashing	Fix retentate line below fluid/in feed air interface container
	Pump cavitation	Check feed tubing to pump connection for obstruction; remove obstruction or replace damaged/collapsed tubing
Nuts do not move freely	Damaged thread on tie rod or nuts	Check thread for nicks or dents; if found replace tie rod or nuts.

## Warranty

The applicable warranty for the products listed in this publication may be found at [www.millipore.com/terms](http://www.millipore.com/terms) (within the "Terms and Conditions of Sale" applicable to your purchase transaction).

We provide information and advice to our customers on application technologies and regulatory matters to the best of our knowledge and ability, but without obligation or liability. Existing laws and regulations are to be observed in all cases by our customers. This also applies in respect to any rights of third parties. Our information and advice do not relieve our customers of their own responsibility for checking the suitability of our products for the envisaged purpose.

For worldwide contact information and technical assistance please visit:  
[www.sigma-aldrich.com](http://www.sigma-aldrich.com)

For additional information and documentation please contact:  
Merck KGaA, Darmstadt, Germany  
Corporation with General Partners  
Frankfurter Str. 250  
64293 Darmstadt, Germany  
Phone: + 49 6151-72 0

The vibrant M, Millipore, Pellicon, Ultracel and Biomax are trademarks of Merck KGaA, Darmstadt, Germany or its affiliates. All other trademarks are the property of their respective owners. Detailed information on trademarks is available via publicly accessible resources.

MS\_AN1065EN00 Rev 7, 04/2021. © 2006-2021 Merck KGaA, Darmstadt, Germany and/or its affiliates. All Rights Reserved.

The logo for Millipore Sigma, featuring the word "MILLIPORE" in a bold, blue, sans-serif font above the word "SIGMA" in a similar bold, blue, sans-serif font. The letters are closely spaced and have a slight shadow effect.