

BELL LABORATORIES RECORD

NOVEMBER 1943

VOLUME XXII

NUMBER III

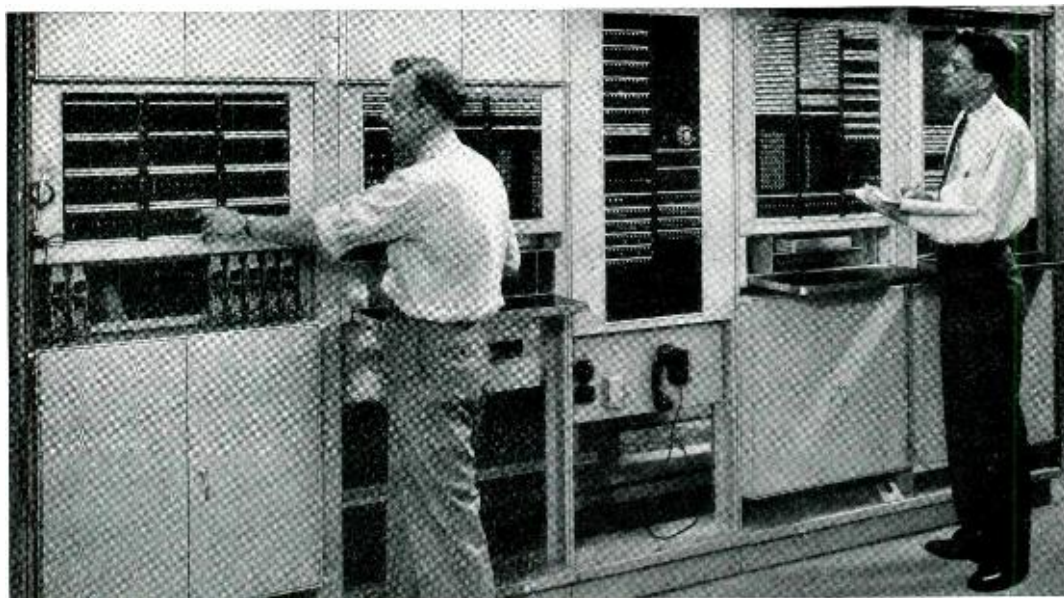

Philadelphia Adopts Automatic Toll Switching

By B. C. BELLOWS
Toll Facilities Director

THE new No. 4 Toll Crossbar System, which was cut into service in Philadelphia on August 22, is arranged to complete connections from trunks from outward toll positions to toll lines for outward calls; from toll lines to trunks to local offices for terminating calls; and from one toll line to another for calls switched through Philadelphia. Outward calls, and incoming calls from toll lines equipped for toll-line dialing, are switched automatically under control of dials or keysets at the originating end of the trunk or toll line. Incoming calls from other toll lines are routed to operator positions, and keysets at these positions control the

subsequent setting up of the connection. All transmission paths through the equipment are four-wire, and telephone repeaters are cut in automatically when required. Another important feature is the use of the multi-frequency method for the transmission of switching codes.

With this new system, crossbar switches with senders and markers are used in the same general way as in the local crossbar system, with such variations and additions as the handling of toll traffic requires. The operator positions, shown on the cover, which supplement the mechanical switching system for handling terminating and through calls from toll lines not equipped for toll-

line dialing, are of the cordless type, but cord positions are used to facilitate the proper handling of traffic over badly congested toll-line groups. The system permits the use of toll-line dialing into a city where local service is given through panel or crossbar offices. The various types of calls handled through the system are shown in Figure 1.

The introduction of this system leaves the handling of outward traffic at the same positions at which it was formerly handled. Since access to toll lines is through the No. 4 equipment instead of through a manual tandem position, however, keysets or dials were added to those outward positions not formerly so equipped. In handling an outward call, the operator keys or dials a three-digit code to reach a toll-line group. If the group concerned is equipped for toll-line

dialing, this code is followed by the necessary codes to control switching equipment at a distant office—the listed number if that office is the terminal office, preceded by a three-digit code if another switch is required to reach the terminal office.

On incoming traffic from toll-line-dialing groups, senders in the No. 4 equipment accept pulses from the distant offices, and control the switching of the connection to the subscriber in the Philadelphia toll center area if the call terminates there. If the call is to be switched to another toll line, the senders also control the connection, and forward pulses to the next office if the toll line selected is of the dialing type.

Incoming calls from toll lines not equipped for toll-line dialing (ringdown or straightforward) are automatically

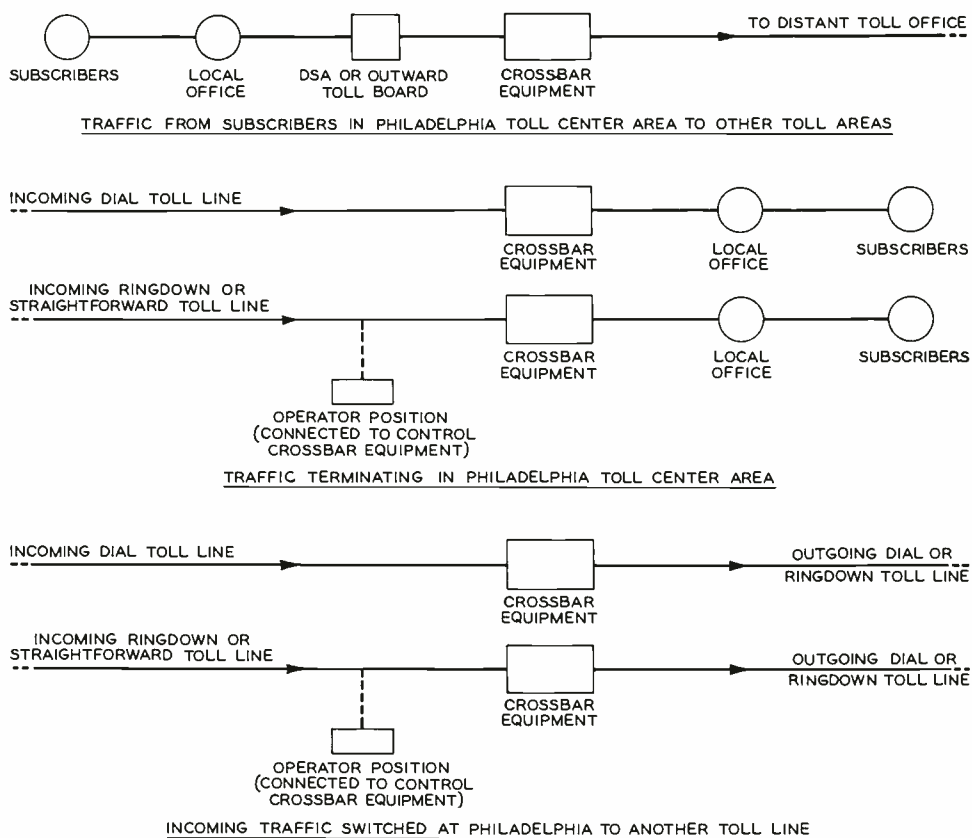

Fig. 1—Types of toll calls handled by the new No. 4 crossbar system

connected to the cordless positions. These are equipped with eleven rows of ten-button keys to control the setting up of connections, and various other keys and lamps to provide for other operating functions. If, for example, a call cannot be completed because the called line is busy or does not answer, a position is connected so that the proper oral report may be passed to the calling operator. Lamps indicate which report should be given. The proportion of calls handled on these positions will decrease as more toll-line groups are converted to toll-line dialing in the future.

Talking paths of all connections through the equipment are four-wire. Trunks or toll lines which are not four-wire are converted to four-wire through hybrid coils before being connected to the equipment. Gain is introduced automatically in any connection requiring it through the use of switched-in repeaters.

Where two-wire switching has been used, incoming trunks of the four-wire type (including two-wire toll lines with terminal repeaters) must be reduced to two-wire before being connected to the switching equipment. In the hybrid coil arrangement which makes this transition is a network that should balance the impedance of any trunk to which connection must be made. There is a considerable proportion of the trunks on which it is economically impracticable to make the impedance uniform, such as trunks to local offices and non-repeated two-wire toll lines. A compromise value for the balancing network toward such trunks must, therefore, be used, and the gain in the terminal repeaters is thereby limited. With four-wire switch-

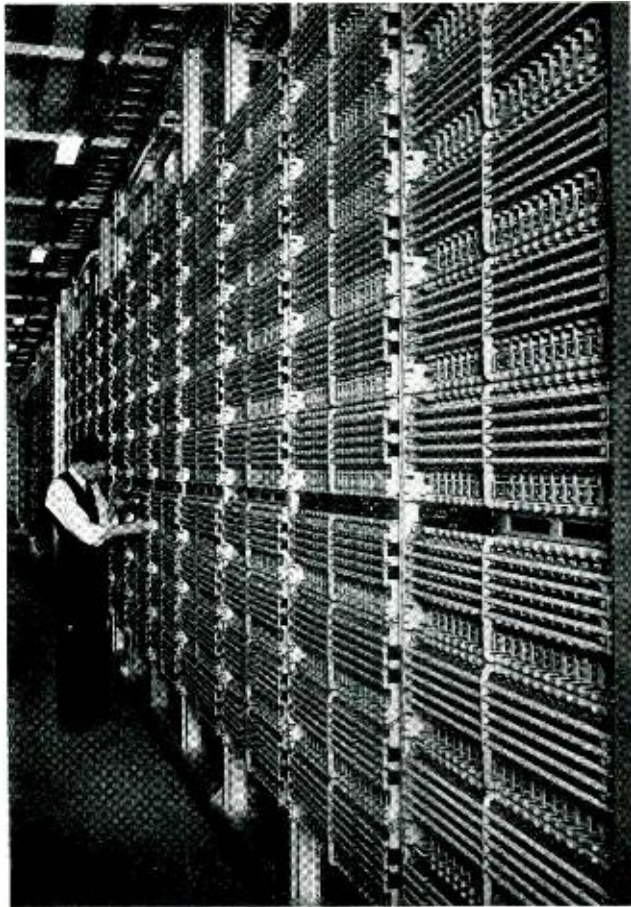

Fig. 2—Crossbar link frames used for handling incoming trunks in the Philadelphia toll office

ing, the balancing networks are associated with individual trunks wherever hybrid coils are needed to permit connection between four-wire and two-wire terminations. They may therefore be precise, and the gain from terminal repeaters may be substantially higher.

The principal economies to be gained from using four-wire switching come from the fact that it permits making many trunks or toll lines high loss by omitting terminal repeaters or using lower grade outside plant. When two such lines are connected together, repeaters are switched in—a provision that is much more difficult to make with two-wire switching because of the balance problems previously referred to.

When such a line is connected to a low-loss line, it is simply necessary to remove a pad normally used in the low-loss line, thereby using the extra gain obtained from the terminal repeater. Four-wire switching also makes it economically possible to bring the overall transmission on switched traffic nearer to that obtained when direct circuits are used.

As in local crossbar offices, automatic testing is provided where needed. There are two trouble indicators, each serving a different group of equipment. These are shown at the right in the photograph at the head of this article. When trouble occurs these indicators furnish a very complete record of the equipment concerned, and so far as practicable the nature of the trouble. These are similar to the trouble indicators provided in local crossbar offices. A very complete system of traffic registers and meters is also provided. These permit measuring

the load carried by various parts of the equipment, thus permitting proper balance in the use of the equipment and assuring the ability to carry maximum load without objectionable service delays. One meter makes a record of calls waiting on the cordless operator positions, which is valuable in the control of proper operator assignment.

Since the estimated load is close to the capacity of the equipment, it was not considered wise to make a complete cutover at one time. The first cut transferred 1,160 toll lines and, as a result, about 100,000 calls a day are being handled through the new system. As it would have been difficult and expensive to keep some of the old manual through positions and provide for switching a call through both these and the No. 4 equipment, all toll lines carrying traffic switched through Philadelphia were included in the first cutover. The remaining 646 toll lines handle only terminal traffic, and are to points to which the traffic volume is large enough to make the provision of a separate group of toll lines for the terminal traffic desirable and economical. These lines were cut over during October.

This cutover introduces the use of multi-frequency keying in handling toll traffic. When a digit key is operated, two of five frequencies in the voice range are transmitted, and the receiver identifies the digit from the two frequencies received. Keysets of this type were installed at the outward positions of the two largest outward units at Philadelphia. They will also be used for pulsing from Baltimore and New York to Philadelphia when those terminal groups are cut over. This is the fastest method for the transmission of switching codes yet used, the system being capable of handling ten digits per second. As at present applied, the speed is limited by the speed with which the operator can operate the sending keyset, which is about two digits per second.

THE AUTHOR: B. C. BELLOWS received his M.E. degree from Cornell in 1906; he immediately joined the A T & T and two years later went to St. Louis as division supervisor for the Long Lines, but in six months returned to his former duties in New York and soon became Toll Line Engineer. In 1912 he joined the Western Union Telegraph Company as



B. C. BELLOWS

Toll Line Engineer, and later became Traffic Engineer. Late in 1914 he returned to the Long Lines as Service Engineer. In 1920 he became Division Traffic Supervisor for the Long Lines in Chicago, and three years later transferred to the Illinois Bell Telephone Company as General Supervisor of Toll Traffic. In 1926 he joined the D & R as Toll Systems Facilities Engineer. He came to the Laboratories with the transfer of the D & R in 1934 and is now Director of Toll Facilities.

Historic Firsts: The Thermophone

“WHEN you can measure what you are speaking about,” according to the famous dictum of Lord Kelvin, “and express it in numbers, you know something about it; but when you cannot measure it, when you cannot express it in numbers, your knowledge is of a meagre and unsatisfactory kind.”

Very meagre and unsatisfactory, prior to the late 1910's, was the information about speech, the vocal product which the telephone transmits, and about the sensitivity of the ear, the organ which leads to its perception.

Following the development of the high-vacuum amplifier — which, of course, as an oscillator, could also serve as a current source of controllable frequency—Bell Telephone Laboratories intensified its program of research in speech and hearing. Important research tools were the condenser microphone and the thermophone. Through their use—with associated apparatus developed for the purpose—it became possible to make absolute measurements of sound. The pressure, for example, delivered by a sound to the ear drum could be quite precisely determined in the physical units for pressures, namely dynes per square centimeter. Using these devices there was initiated under the direction of Harvey Fletcher a productive series of researches which have contributed definitively to all the telephonic arts including sound motion pic-

tures, radio broadcasting, phonographs and hearing aids.

The word “thermophone” has been used with various meanings but at present is synonymous with “thermal telephone receiver.”

That an alternating current in a conductor (of small heat capacity) causes alternations in temperature and, as a result, a periodic expansion and contraction of the adjacent air had long been recognized. The application of this phenomenon, however, to a telephone receiver, which could serve as a quantitatively con-

trollable source of sound, was the development of H. D. Arnold and I. B. Crandall, with contributions by E. C. Wentz. Their description of this new instrument in the *Physical Review* (1917 and 1922) was under the title “thermophone” and that use of the word has since been standardized by the I.R.E., A.S.A. and A.I.E.E.

The thermophone was adapted to two classes of service: as a precise source of sound at any frequency determined by the current supplied to it; or, as a source of sound of known relative loudness at different frequencies throughout the acoustic range. Its basic contribution to acoustics was in calibrating condenser microphones so as to relate, in absolute units, output voltage to input sound pressure. With that accomplished the acoustics of speech and hearing was definitely placed upon a precise basis.

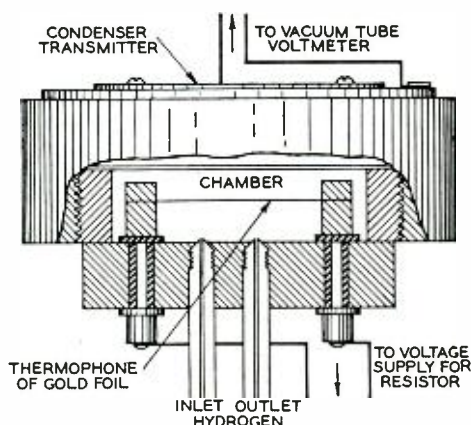

Thermophone calibration by means of the condenser microphone



Locating Buried Cables Electrically

By R. M. C. GREENIDGE

Outside Plant Development

IN THE maintenance of buried inter-city cables it is sometimes necessary to install, for protection against damage by lightning, copper shield wires above a cable already in the ground. Since these wires are placed by a plow, the precise route of the cable has to be determined so that the shield wires can be correctly positioned. It is also important to know the depth of the cable, so that damage to it may be avoided while installing the shield wires. Irregularities in terrain make this depth vary; and the track left by the plow, which buried the cable, soon becomes obliterated, particularly in cultivated land and in swamps. Sometimes the path and depth have to be determined almost continuously over long distances. This can now be done electrically with a simple device which consists of coils

that pick up a tone which has been applied to the cable sheath.

The principle is illustrated in Figure 1, where L is a wire carrying an alternating current. If a coil is held nearby, as in position x , so that the magnetic flux F generated by this current passes through its windings, voltage will be produced across the terminals of the coil and can be detected, after amplification, as an audible tone. If the coil is held in position y , however, with its axis perpendicular to the wire, the flux generates equal and opposite voltages in each half of the windings and no tone will be heard; also if the coil is held in position z , so that the windings are coplanar with the lines of flux, there will be no tone produced.

Construction of the device is shown in Figure 2. The locating coil A , the

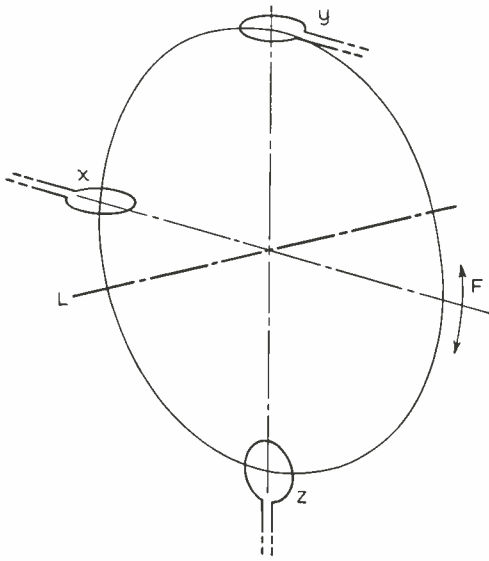

testing valve and the other to a ground rod located from fifty to one hundred feet from the cable. Current flows along the sheath in both directions, and through earth to the ground rod. With the amplifier operating and earphones as detector the selector switch is set on position a, and the apparatus carried across the path of the cable. When coil A comes directly over the cable, a null position (y in Figure 1) is reached and at this point the spike is pushed into the ground, thus locating coil A directly

Fig. 1—Diagram illustrating the principle of the cable depth-exploring device. The magnetic flux F , generated by an alternating current in the wire L , induces voltage in the coil x but none in y , whose axis is perpendicular to the wire, or in z , whose windings are coplanar with the lines of flux

direction coil B and the depth coil c are mounted on a crossbar T attached to a vertical rod which supports a graduated scale s and has a spirit level L on its upper end. A handle H is used to position the apparatus by forcing the spike K into the ground. The selector switch w connects any one of the three coils to the amplifier and detector circuit, which is connected at x . A pointer P indicates the setting of the depth coil c and the shaft F , which slides vertically, permits leveling the apparatus.

The test current is generated by the buzzer of a 20C test set. One of its terminals is connected to the cable sheath at a pressure-

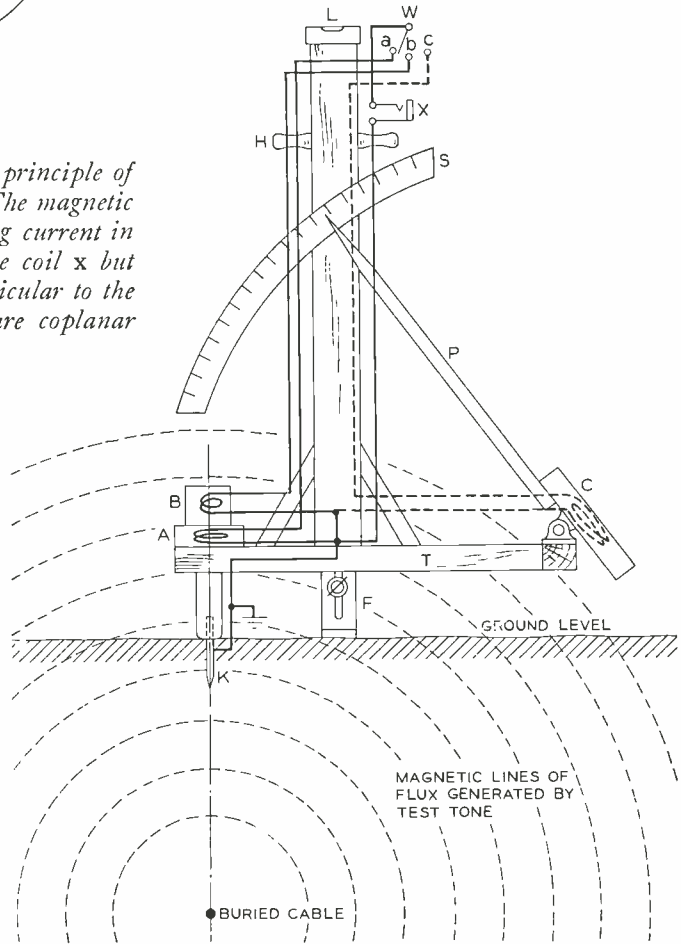

Fig. 2—The locating coil A, the direction coil B and the depth coil c are mounted on a crossbar attached to a vertical rod which supports a graduated scale s . A pointer v indicates the setting of the depth coil. Adjusting the position and direction of the apparatus and the inclination of coil c to give null readings successively in each coil locates the cable and determines its depth

over the cable. By setting the selector switch at b and rotating the apparatus around the spike, the null point of coil B is found. In this position the horizontal bar on which coil c is located is at right angles to the path of the cable. Adjusting the sliding shaft then levels the device, after which the selector switch is set at c and the depth coil rotated on its pivot for the null point. The reading on the scale, as indicated by the pointer, is the distance of the center of the cable below the surface. If r , Figure 3, is the radius of the cable, h the height of the coils above the ground, l the distance between the coils A and c, and d the depth of the cable, $d = l \cot \theta - k$ where $k = r + h$. By this formula the quadrant scale, s of Figure 2, can be calibrated for depth.

The depth indicator is usually handled by a group of three men. One operates the apparatus and another measures distances along the cable and places marker flags. The third member takes notes and carries the flags. The depth indicator is shown in use in Figure 4. In good going, where the cable is buried to a depth of twenty-five inches or more,



Fig. 4—Cable depth indicator in use. Notes were kept for the plow operators

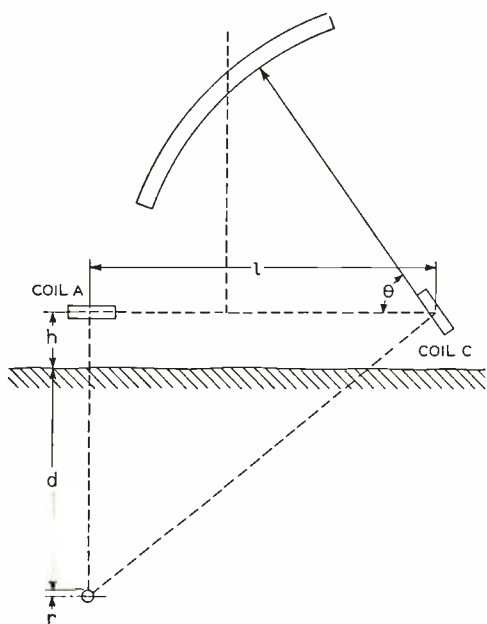

Fig. 3—If r is the radius of the cable, h the height of the coils above the ground, l the distance between the coils and d the depth of the cable, $d = l \cot \theta - k$ where $k = r + h$

measurements are taken every fifty feet. White flags are placed every hundred yards or less to mark the path of the cable. In rocky terrain, or in places where washouts have occurred, measurements are made more frequently because in such locations the cable is apt to be at a relatively shallow depth. Where the depth of the cable is between twenty and twenty-five inches, yellow flags are used; and red ones are used if the depth is less than twenty inches.

The headpiece shows a plow crossing a creek in the process of laying wires above buried cable and Figure 5 the same operation under more favorable conditions in flat terrain. In areas where the cable is near enough to the surface

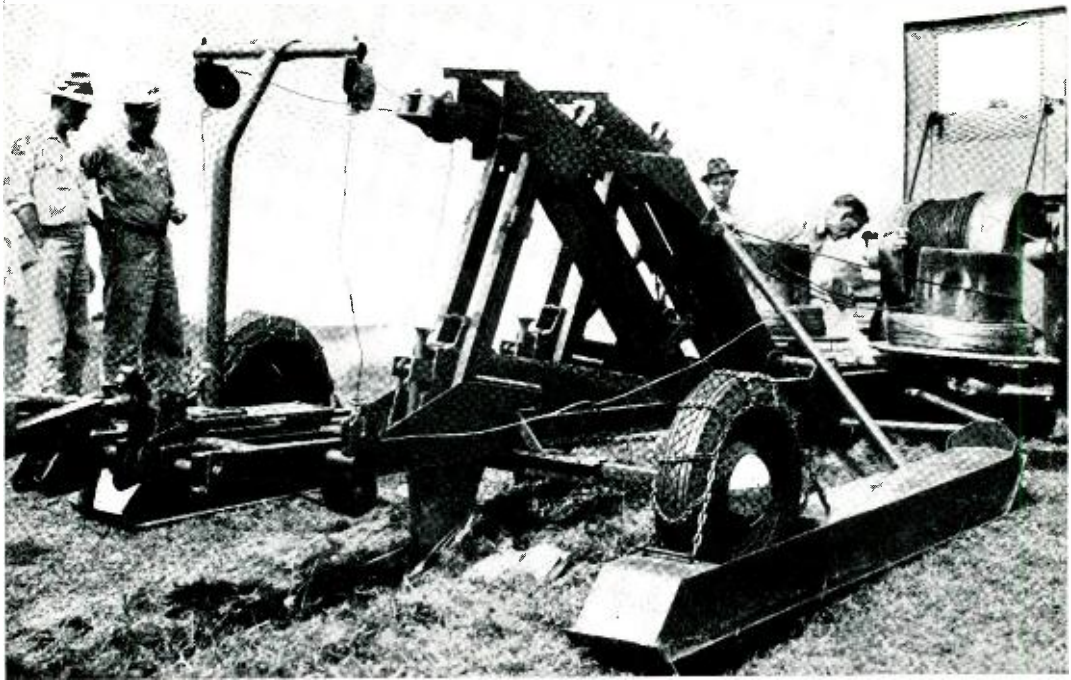

Fig. 5—Two standard wire-laying plows adapted to form a dual unit for laying shield wires simultaneously on each side of a cable. pontoons insure placing the wires at uniform depth

to require red flags to warn the plow operators against the possibility of hitting the buried cable with the point of the plowshare, the depth at which the wires are plowed in is governed by the notes taken during the survey. The plowshare is raised, where possible, so that the wires will be buried at less than the normal depth of 16 inches below the surface of the ground. As a check on the accuracy of the survey² and also the

guiding of the tractor and plow, test holes are dug at intervals to expose the wires and cable after the plow has passed. In most cases the two wires straddle the cable almost exactly and are about four inches distant on each side, but in some instances they are off center by two or three inches. As a result of the depth survey and the precautions during the plowing, damage to the cable is completely avoided.



R. M. C. GREENIDGE

THE AUTHOR: After receiving the B.S. degree in Mechanical Engineering from Harvard University in 1924, R. M. C. GREENIDGE immediately joined the Apparatus Development Department of the Laboratories. Magnetic materials and loading coils were his first assignment. Later he was in charge of a group engaged in developing loading and retardation coils. In 1940 Mr. Greenidge transferred to the Outside Plant Development Department to devise testing apparatus for locating cable faults. The war finds him again with Apparatus Development where he is working on quartz-crystal devices.

Pulsing Between Dial and Manual Offices

By H. C. CAVERLY
Switching Development

WHEN a subscriber in a manual office desires a subscriber in a step-by-step office, the number is given to an "A" operator who completes the call by plugging into a trunk to the desired office and then dialing the number. A subscriber in a step-by-step office usually reaches a subscriber in a manual office within his local dialing area by dialing the number as though it were in another dial office. The pulses are received in the manual office by switches that display the number on a call indicator at the manual "B" board.

In panel and crossbar areas dials are also employed at certain switchboards, but since senders can count and record pulses faster than step-by-step switches can respond to them, a dial operating at a speed of about twice that of the subscriber's dial, or 20 pulses per second, is employed. Because of the wind-up and search time, however, this doubling of the pulsing speed does not halve the dialing speed, but the average operator dialing time is reduced from 20 to 25 per cent, and the call-completion time, the operator-work time, and the sender-holding time are all reduced accordingly.

To provide for the normal flow of traffic from panel to manual offices, the call indicator* is employed. At the "B" positions in the manual offices there is fitted in the key shelf a

*RECORD, Dec., 1929, p. 171.

small rectangular box in which illuminated numbers and letters indicate the number of the line wanted. Associated with it is a circuit that records and translates pulses sent from the originating sender, of either the panel or crossbar type, into signals that will light the proper numbers. All originating senders are equipped with a circuit to send out the required pulses when the number received from the subscriber is that of a manual line. Since this system was developed for the panel system, it was called the panel call-indicator—PCI—system, and the pulses sent are called PCI pulses.

The nature of PCI pulses, and the circuit that sends them, have already been described in the RECORD.* Although the circuit described is that used with the crossbar system, the type of pulses is the same for both, since both of the systems must work into the same circuits at the manual "B" switchboard.

The circuit employed is shown in

*RECORD, April, 1940, p. 236.

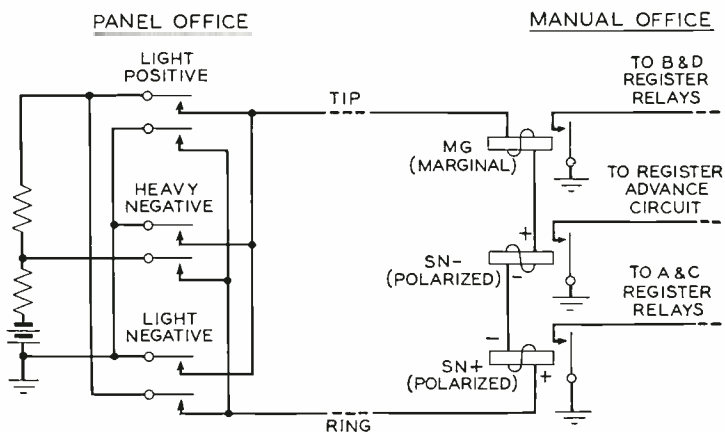

Fig. 1—Simplified schematic of PCI pulsing circuit

TABLE I—DIGITS DIALED, PULSES SENT, RELAYS OPERATED AND DIGITS DISPLAYED IN THE PCI SYSTEM

<i>Digits Dialed</i>			<i>Pulses Sent</i>				<i>Register Relays Operated</i>	<i>Digits Displayed</i>		
<i>Th</i>	<i>St</i>	<i>Other</i>	<i>1st</i>	<i>2nd</i>	<i>3rd</i>	<i>4th</i>		<i>Th</i>	<i>St</i>	<i>Other</i>
0	0	0	—	LN	—	LN		0	0	0
2	1	1	LP	LN	—	LN	A	2	1	1
4	W	2	—	HN	—	LN	B	4	W	2
6	R	3	LP	HN	—	LN	A & B	6	R	3
8	J	4	—	LN	LP	LN	C	8	J	4
1	M	5	—	LN	—	HN	D	1	M	5
3	—	6	LP	LN	—	HN	A & D	3	—	6
5	—	7	—	HN	—	HN	B & D	5	—	7
7	—	8	LP	HN	—	HN	A & B & D	7	—	8
9	—	9	—	LN	LP	HN	C & D	9	—	9

simplified schematic form in Figure 1. At the manual office the tip and ring conductors are connected to the windings of three relays in series to form a loop circuit supplied by battery at the panel office. Two of the relays are of the polarized type; one operates when the tip is positive, and the other when the ring is positive. The third relay is of the marginal type. It will operate when either the tip or ring is positive but requires a larger current than the other two. The circuits at the dial office, shown in detail in the article already referred to, are indicated in Figure 1 only as sources of the three types of pulses sent. A fourth type of pulse, heavy current with ring positive, is sent at the end of the complete number.

From the three relays at the call-indicator end of the circuit, leads run through the contacts of transfer and advance relays to a set of four register relays for each digit or letter to be recorded. The register relays are designated A, B, C, and D. Relay MG operates either register relay B or D, and relay SN+ operates A or C. In each case the A or B register relay is operated unless the advance circuit, operated by control relay SN-, has been operated previously.

The combinations of pulses sent for the various digits and station letters, the register relays operated, and the

digits displayed are shown in Table I. The pulsing period allowed for each digit is divided into four intervals, and in two or three of these intervals one or another of the four types of pulses is sent. To transmit either a hundreds, tens, or units digit 6, for example, the code is LP, LN, —, HN, no signal being sent for the third interval. The LP pulse operates register relay A, the LN pulse operates the register advance circuit, and thus the last HN pulse operates the D register relay. With A and D register relays operated, the digit recorded is 6. It will be noticed in Table I that the order of pulses for the thousands digit is different from that for the other digits.

TABLE II—THREE-WIRE DIRECT-CURRENT KEY PULSING CODES

<i>Digits Dialed</i>	<i>Pulses Sent</i>			<i>Register Relays Operated</i>
	<i>Lead 1</i>	<i>Lead 2</i>	<i>Lead 3</i>	
0	—	—	H	3
1	H	—	H	1, 3, 4
2	L	—	H	1, 3
3	—	H	H	1, 2, 3, 4
4	—	L	H	1, 2, 3
5	—	—	L	None
6	H	—	L	1, 4
7	L	—	L	1
8	—	H	L	1, 2, 4
9	—	L	L	1, 2

This difference permitted a more economical arrangement in the senders for controlling incoming brush selections.

Call-indicator pulsing circuits are incorporated in all originating crossbar and panel senders, and PCI pulsing is the normal method for completing a call to a manual office that originates in either a panel or crossbar office. Provisions must also be made for the reverse operation, so as to permit a call coming in to a manual office to be completed to a dial office. This is done by having the manual "A" operators extend the calls to a "B" board in the panel office called. Instead of a dial,

however, the panel "B" operators are provided with a set of ten non-locking buttons called a ten-button keyset. The buttons are numbered 0 to 9 inclusive, and a correspondingly numbered button is pushed for each digit of the number wanted. This gives much faster operation than the dial. The average time per digit using the 20-pulse-per-second dial is about one second, while with a keyset, numbers can be sent at a rate of approximately ten digits per second as far as the mechanical equipment is concerned, although the normal speed at which operators "write up" numbers on the keyset is

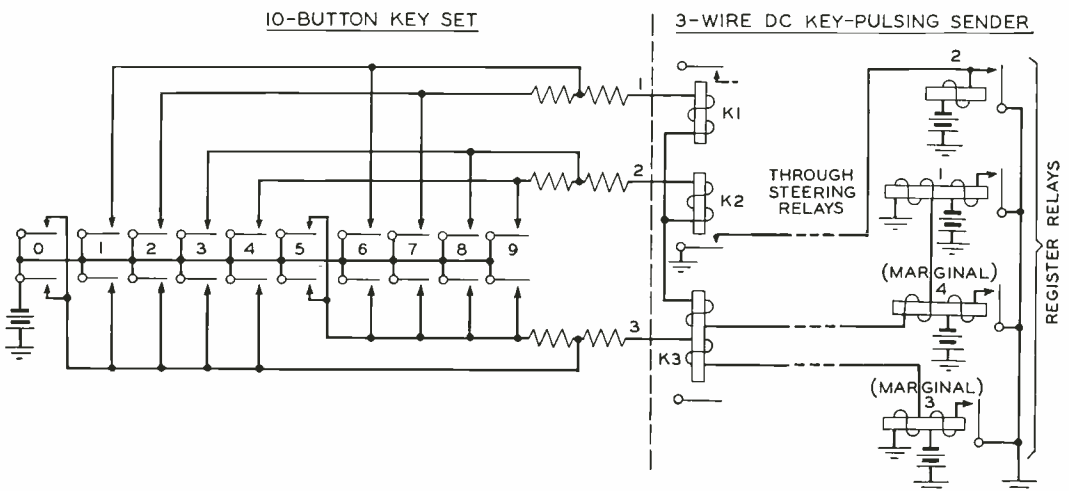

Fig. 2—Simplified schematic for three-wire d-c key pulsing circuit

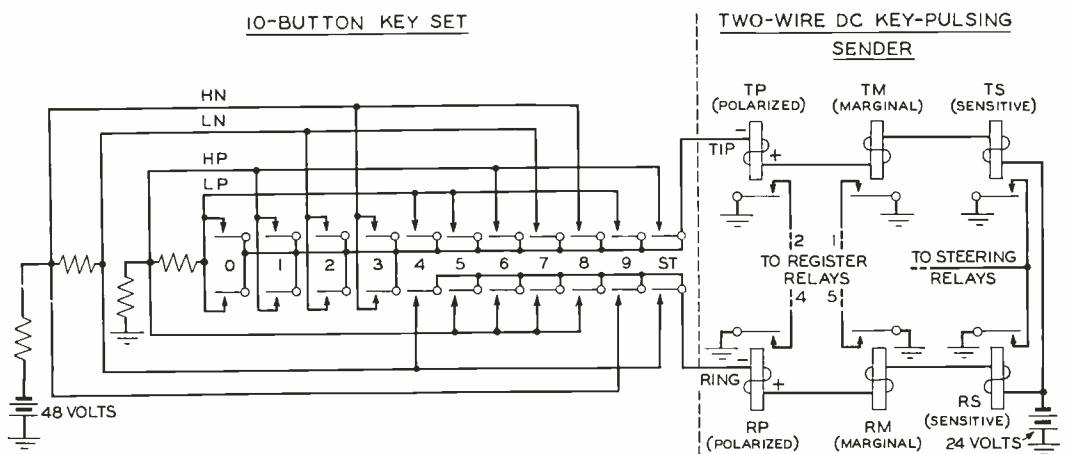

Fig. 3—Simplified schematic of two-wire key-pulsing circuit

more nearly four per second. Each key, when depressed, closes a set of contacts that sends pulses from battery over the conductors of the connecting circuit.

In conjunction with these "B"-position keysets, a sender was developed with a circuit that would receive and record this type of pulses instead of dial pulses. Since these senders are directly associated with the "B" position, a three-wire circuit could be used between the keyset and the sender, and the keyset is arranged to send pulses over one or two of the three leads for each digit.

All pulses are of the same polarity, but they may be either heavy or light and may be over lead 3 alone, for digits 0 and 5, or over either 1 and 3 or 2 and 3 for the other digits. The combinations of pulses sent for the various digits, and the register relays they operate, are shown in Table II. In Figure 2 a schematic of the pulsing circuit is shown for this system, which is known as three-wire d-c key pulsing.

For all digits, relay κ_3 is operated, and serves to advance the circuit to the next set of register relays after the digit

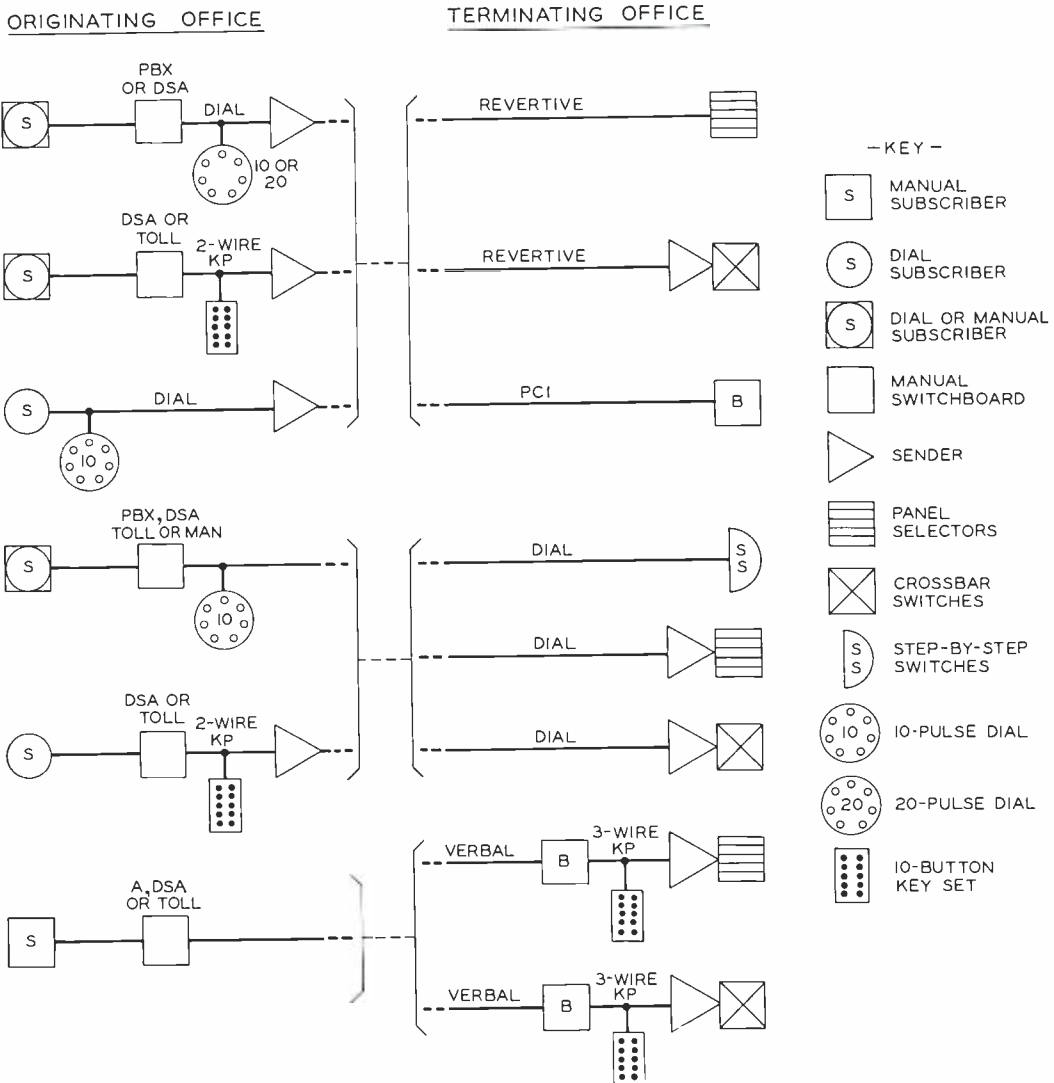

Fig. 4—Diagrammatic representation of situations using various types of pulsing

TABLE III—COMBINATION OF PULSES SENT AND REGISTER RELAYS OPERATED WITH TWO-WIRE KEY PULSING

Digits Keyed	Pulses Sent on		Register Relays Operated
	Tip	Ring	
0	LP	—	None
1	HP	—	1
2	LN	—	2
3	HN	—	1, 2
4	LP	LN	4
5	LP	HP	5
6	HP	HP	1, 5
7	LN	HP	2, 5
8	HN	HP	1, 2, 5
9	LP	HN	4, 5

keyed is recorded. A light pulse over the No. 3 lead operates the κ_3 relay alone, while a heavy pulse operates the No. 3 register relay as well. A light pulse over the No. 1 lead operates the No. 1 register relay, and a heavy pulse, both the No. 1 and No. 4 register relays. A pulse over No. 2 lead does the same as one over the No. 1 lead and in addition operates the No. 2 register relay. After the number has been recorded, the sender controls the completion of the call in the usual manner in either a crossbar or panel office.

At certain toll and DSA boards, high-speed dials have been employed to permit the operators to complete calls to panel and crossbar offices as has already been noted. Where there are many dial calls to be completed from such positions, faster operation than the dial permits is desirable. At such locations only two conductors in the cord are available for the pulsing circuit, however, and thus the key-pulsing circuit already described was not suitable. A two-wire key-pulsing system was thus developed.

This system uses a keyset as for three-wire key pulsing, but requires a two-wire key-pulsing sender at the toll or DSA office. Since only two conductors

are used for pulsing, the connections of the contacts of the keyset differ from those for three-wire key-pulsing. The pulses employed resemble those of the call-indicator system in being of two strengths and two polarities of current, and they are received by polarized and marginal relays. With the call-indicator system, however, the pulses go from one office to another, and because of the possibility of differences in ground potentials at the two offices, the receiving relays are connected into a loop circuit with battery and ground supplied only at the sending end. With such a system the number of receiving relays that can be operated at one time is limited to two, but this handicap is overcome in the PCI system by allowing four pulse positions for each digit. With two-wire key-pulsing, on the other hand, only one set of pulses is sent for each digit, but one pulse is sent over each conductor, each of which has three relays connected to 24-volt battery. The circuit is shown in Figure 3. A 48-volt battery, ground, and two values of resistance at the sending end, and a 24-volt battery at the receiving end, permit pulses of either

THE AUTHOR: Beginning his telephone career with the New England Company,



H. C. CAVERLY

H. C. CAVERLY'S first work was subscriber's station installing, on which he worked for three years. He was appointed manager of the Southbridge exchange in 1903, and in 1906 assumed similar charge at Marlboro. In 1909 he went to Worcester as private-branch exchange

and central-office installer, and came from that city to the Laboratories in 1919. His work with the Systems Development Department has been devoted entirely to sender development.

polarity and strength of current to be sent over the two conductors simultaneously but independently.

This system employs four register relays, 1, 2, 4, and 5, and the sum of the numbers of the relays operated indicates the digit recorded. Of the three relays in each side, one is polarized to operate only on negative pulses, one is marginal and operates only on heavy current, and the third is a sensitive relay that operates on pulses of either polarity and either strength. This latter relay controls only the steering circuit that switches the leads to successive sets of

register relays. The pulses are sent by operation of the various keys, and the register relays operated as a result are shown in Table III.

A similar two-wire key-pulsing system is sometimes employed in step-by-step areas, but the senders associated with it must be arranged to send out dial pulses, while the senders in the panel areas operate on revertive pulses.

The situation employing these various kinds of pulsing are indicated diagrammatically in Figure 4, which is an extension of the chart given in the pulsing article published in the August issue.

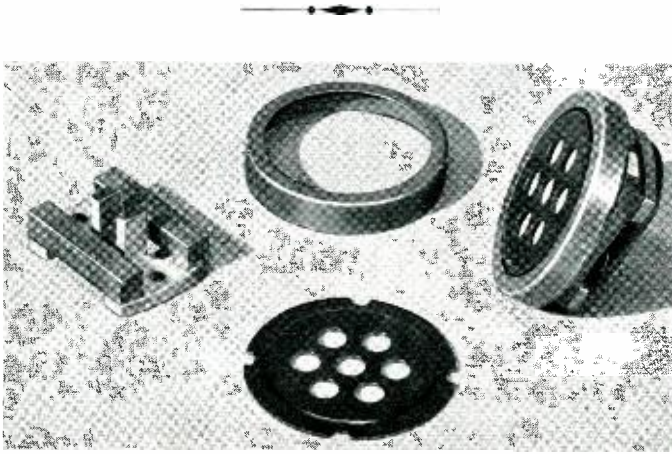

STEEL REPLACES COPPER IN HANDSET PARTS

WAR needs for strategic materials required that the aluminum grids and ferrules of handset transmitters and receivers be changed to copper and then to steel. After receiving a coating of zinc the steel grids are finished in black enamel. The ferrules are dipped in dichromate to inhibit corrosion of the zinc. To reduce telephone

use of nickel, silicon steel has been substituted for permalloy in the cores of the receiver units. This change tends to decrease the efficiency of the unit but it is approximately offset by the effect of the steel grid and ferrule on the magnetic lines through the diaphragm. Transmission data and plant practices are not affected by these changes.

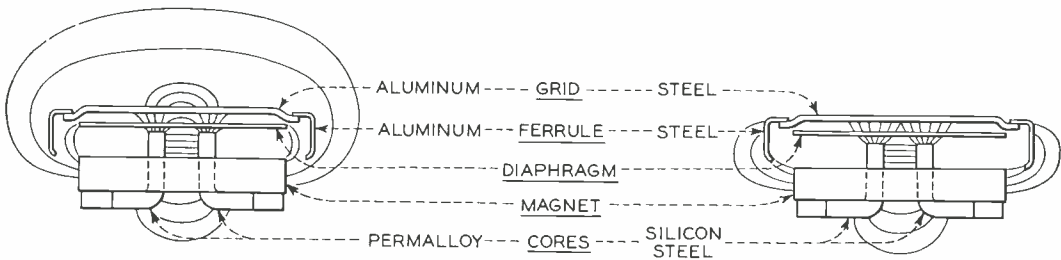



Drop-Wire Painting Tool

By C. C. LAWSON
Outside Plant Development

TO EXTEND the life of drop wire in service and, in the present emergency, to reduce the amount required for maintenance, a tool has been developed by the Laboratories to apply paint to already installed wire and so restore its weatherproofing. The tool, shown in Figure 1, is a trough-shaped container from which paint is applied to drop wire in service by pulling the device along the wire. The wire is kept immersed in the paint by a guide pin, while stiff brushes at one end of the container force the paint

into the braid and remove the excess. By turning the brushes in their holder new bristles can be brought into action when old ones wear. A flexible coating, which penetrates the braid and adheres well to the remaining original finish, is obtained by using Bell System No. 2 asphalt paint. At room temperature it is dry to touch within half an hour.

Prior to painting, the drop is disconnected at the pole and at the upper attachment on the building, so that the wire may be reached from the ground. After inspecting its upper surface, where the effects from weathering are more pronounced, and making minor repairs, such as taping abraded parts or replacing sections of deteriorated wire, painting is begun at the end nearest the building. With the brush end of the tool held toward the building, the wire is pushed under the guide in the container to force it below the surface of the paint, after which it is inserted between the brushes. Drawing the painter along by hand about ten feet per minute insures adequate penetration of the braid and prevents the paint from dripping. Adjacent to the supports of the wire, complete coverage may be obtained by reversing the motion of the tool or its direction. Splices pass readily through the painter and are well coated in the process, but somewhat more thorough protection may be obtained if the movement of the tool is reversed and the splice is passed through a second time.

Several of the associated companies have experimented with drop-wire painters of local design which do not require lowering the wire to apply the paint, Figure 2. The Laboratories has

THE AUTHOR: C. C. LAWSON received the B.S. degree from Yale University in 1925.



C. C. LAWSON

Before coming to the Laboratories he was employed in the Engineering and Inspection Department of the Travelers Insurance Company and also by the Metropolitan Life Insurance Company in their Industrial Hygiene Laboratory. In 1929 he joined the Outside Plant Development Department to work on specifications for vitrified clay conduit and later on the testing of motor vehicle finishes and means of drying cable insulation and splices by the use of desiccants. Since 1935 Mr. Lawson has been concerned with wire development problems, particularly in improving durability of outside distribution wires and developing means of protecting these wires from abrasion. At present he is engaged on the design and development of wires and cables for our armed forces.

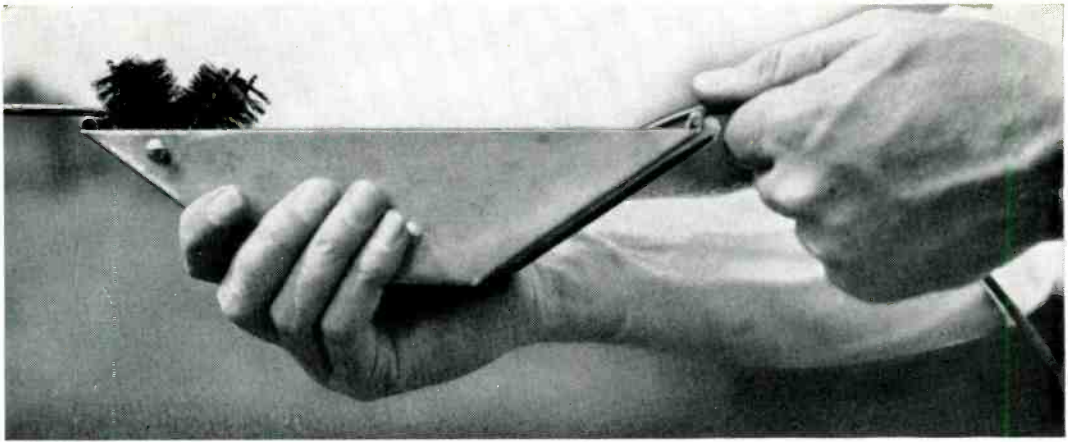
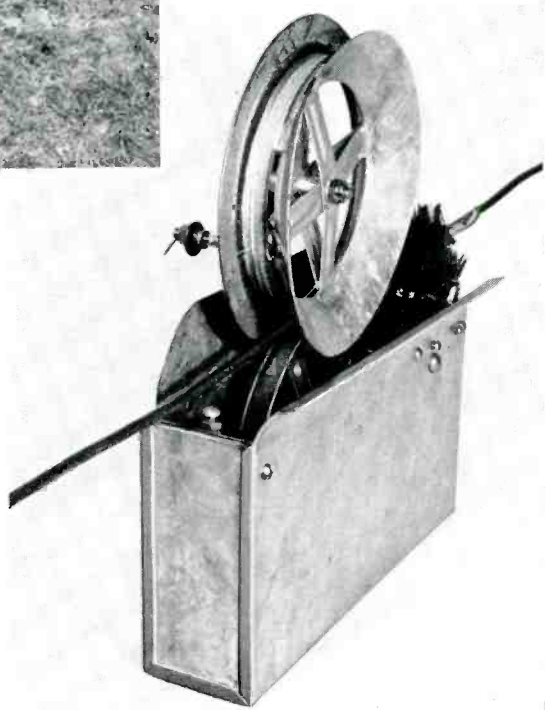

Fig. 1—To extend the useful life of drop wire during the present emergency, a painting tool has been developed to weather-proof the covering of the wire while it is in service



Fig. 2—Albert J. Oppel, repairman in the Newark Suburban District of the New Jersey Bell Telephone Company, uses a drop-wire painter that is attached to a tree pruner handle to permit weather-proofing from the ground

Fig. 3—In the ground-operated painter, the wire passes between two wheels. One is flanged, which serves as guide, and the other has a felt tread to apply the paint



studied these tools and incorporated their best features in the type B aerial drop painter, Figure 3. It is attached to the head section of a tree pruner and is pushed along the wire from the ground. The wire passes between two wheels. One is flanged to guide the tool and the other has a felt tread to apply the paint. The rim of the guide wheel is equipped

with frogs to help in placing the tool on the wire. Brushes distribute the paint and remove the excess.

Painting weathered drops with these devices will keep in service considerable quantities of wire which would otherwise have to be replaced with new wire or with that which had been reconditioned in repair shops.



AUTOMATIC MESSAGE TICKETING

Recently installed message ticketers undergoing test and adjustment at Culver City, California, are shown at the left. These form part of the automatic toll ticketing system that will shortly enable extended-service subscribers in Culver City to dial subscribers in Los Angeles as easily as they now dial a local call. Technical descriptions of this system will appear in the RECORD in forthcoming issues.



Molecular Orientation in Molded Plastics

By W. O. BAKER
Chemical Laboratories

WHEN an organic plastic is forced into the mold of an extrusion press the molecules of the molding material are aligned more or less completely in directions which are determined by the molding conditions. These arrangements of the molecules change the characteristics of the plastic and help to explain why some parts of an object molded by injection, like a hand-set housing, are stronger than others. To study these molecular changes in the laboratory, X-ray diffraction patterns were made of specimens of some of the cellulose esters before and after they had been rolled, stretched or compressed. These mechanical operations produce strains in the material similar to those caused by injection molding.

Under compression, the long axes of the molecules are forced into planes perpendicular to the direction of pressure. This arranges the molecules like a pile of long planks which point in all directions in each layer but which do not project from one layer to another. The random orientation in layers is shown by the pattern of Figure 1A obtained from a sample of cellulose triacetate which had been rolled and was then X-rayed perpendicular to the plane of rolling. The symmetry of the figure indicates no preferred orientation perpendicular to the direction of pressure. When the X-ray beam was parallel to the plane of rolling, however, the rings split into arcs, as shown in Figure 1B, indicating that the molecules are compressed into layers.

The effect of passing organic plastics through an injection nozzle or of drawing operations is illustrated by Figure 1C. It shows exceptional definition for a photograph of its type. A film of cellulose acetate butyrate was prepared from a chloroform solution and cut into strips, which were then elongated by stretching at 200 degrees C. After this treatment the long axes of the molecules are parallel and there is random orientation about the minor axes. These strips resisted folding perpendicular to the direction of stretching but split easily parallel to this direction.

Figure 1D shows the effect of rolling sample c. The pattern is diffuse and many of the arcs are missing. Molecules which had been lined up like cord wood by stretching are now pressed against each other, some thrown askew and the parallelism reduced while preferential ordering occurs around minor axes.

To determine whether the compression after elongation experienced by plastics during injection molding stores strains in the molecules which subsequently cause breaking or warping, the sample of 1D was annealed at 100 degrees C. for three hours. Although 100 degrees below the softening temperature, some of the molecules relaxed into a more ordered state. This is shown in Figure 1E which is less diffuse than 1D. Dimensional changes in molded apparatus thus involve molecular rearrangements and are not solely attributable to inhomogeneities of the various molding compounds.

The effect of compression following elongation is confirmed by the results of elongating after rolling. Pattern 1F was made from an acetate butyrate strip which was rolled and then drawn. The broad arcs show poor parallelism of the long axes after elongation.

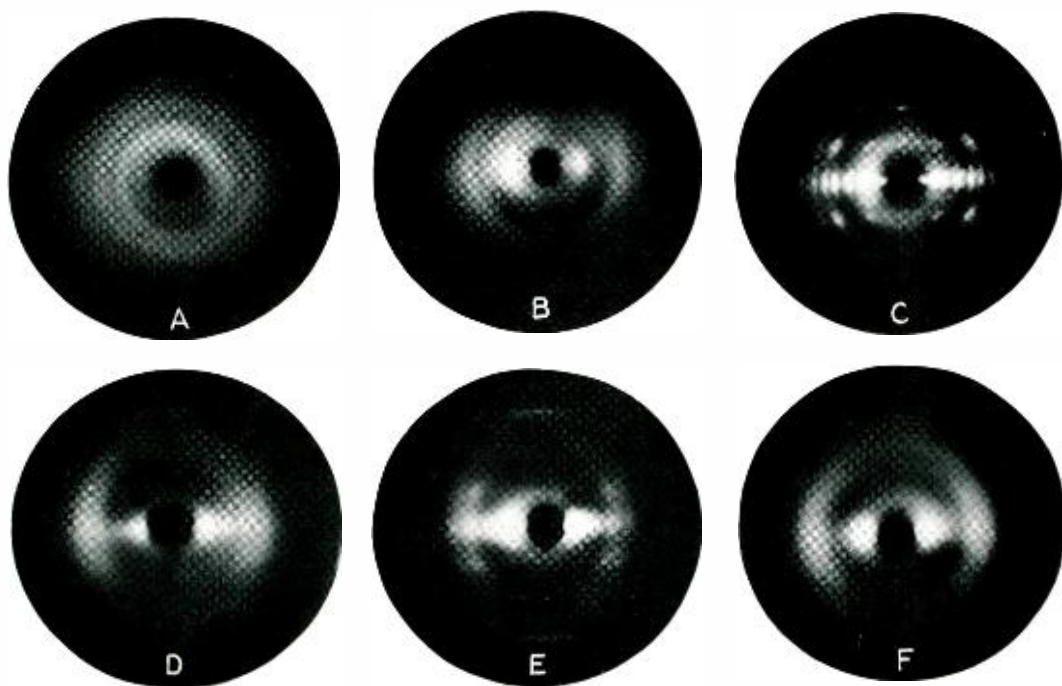

Fig. 1—X-ray patterns of oriented cellulose esters: rolled cellulose triacetate (A) beam perpendicular to plane of rolling, (B) beam parallel to plane of rolling; cellulose acetate butyrate (C) drawn uniaxially, (D) rolled after drawing, beam perpendicular, (E) sample of (D) annealed, same position, (F) sample rolled, then drawn as in (C), beam perpendicular

A high degree of alignment of the molecules in one direction is shown in the pattern of cellulose tributyrate illustrated with unusual detail in Figure 2A. It was obtained with a strip from a quenched sample which was drawn at 150 degrees C. Initial quenching from high temperatures softens the material and favors orientation in an ordered state under mechanical working.

Annealing of this specimen for an hour and a half at 150 degrees C., after drawing, caused loss of orientation which is indicated by the broad rings of Figure 2B. A similar disorientation is shown by a specimen of cellulose acetate butyrate in Figure 2C. These diagrams indicate that molecular orientations tend to disappear in a molding which is held at a high temperature after solidification from the melt. Thus a compression molding of a thermoplastic differs from one made by injection be-

cause molecular orientations that are introduced by compressive shear would probably disappear before the piece could be cooled.

The last three diagrams of Figure 2 also illustrate how strains may be introduced into thermoplastic moldings. Figure 2D shows the pattern from a cellulose triacetate strip with molecular orientation in two directions. It was obtained by both stretching and rolling. This photograph was taken perpendicular to the length of the strip and Figure 2E in the plane of rolling. Figure 2F is from a less highly oriented specimen made by rolling a drawn sample after annealing it. The molecules have been forced from equilibrium positions by the rolling. This is shown by the broad lines of the pattern as compared with that of Figure 2D. A molded object in this condition would crack easily on impact.

X-ray patterns of molded specimens

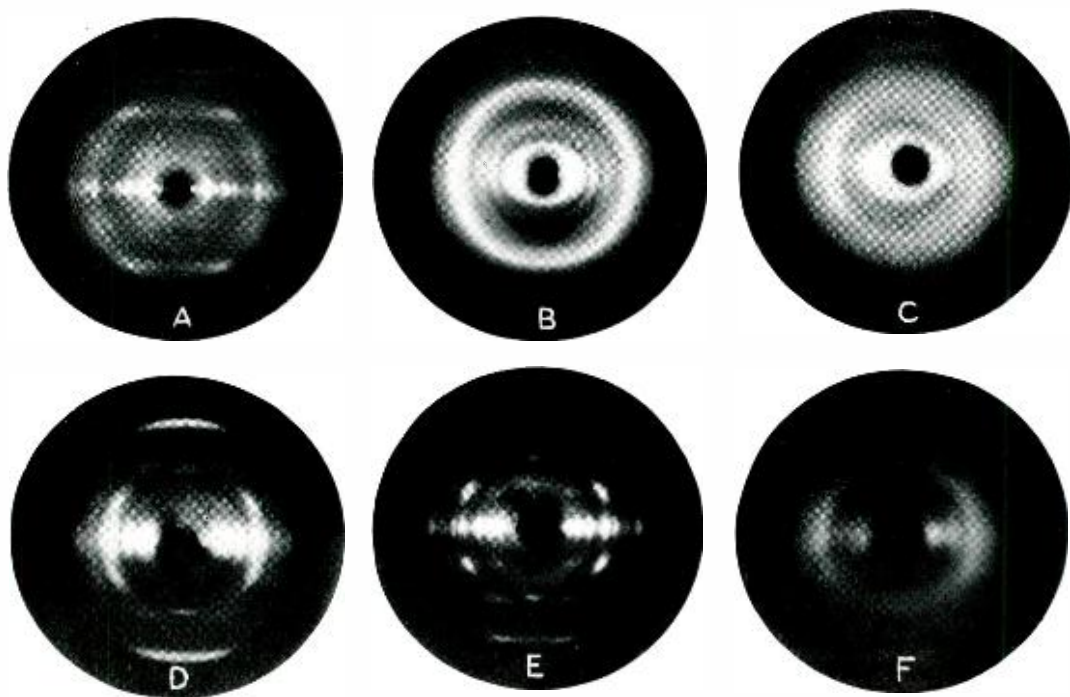

Fig. 2—X-ray patterns of oriented cellulose esters: cellulose tributyrate (A) drawn uniaxially, (B) sample of (A) disoriented thermally; (C) cellulose acetate butyrate drawn and then disoriented thermally; cellulose triacetate (D) drawn and rolled, beam perpendicular to plane of rolling, (E) the same with beam parallel to plane of rolling, (F) drawn, annealed and then rolled

show that the molecular orientations may vary even in a thin section and that surface properties differ from those within. Investigations that have been carried on show that different parts of a handset housing display marked differences in molecular alignment.

Further physical tests must be correlated with these diffraction studies to establish the full significance of the molecular alignments produced by injection molding and other mechanical working. These preliminary studies show, however, that the successive stresses to which plastics are subjected cause molecular rearrangements which affect the tensile strength, elongation and impact resistance of the material and hence the resistance of the final product to distortion and fracture.

THE AUTHOR: W. O. BAKER was graduated from Washington College in 1935 with the B.S. degree and received the Ph.D. from Princeton in 1938. At the latter institution he held a Harvard Fellowship and he was Proctor Fellow at Princeton the year after receiving his doctorate, while engaged in a study of solid dielectrics. In 1939 Dr. Baker joined the Laboratories to work on the physical properties and molecular structure of polymers and plastics. Recently he has investigated synthetic rubbers to correlate their chemical constitution with their physical properties.



W. O. BAKER

joined the Laboratories to work on the physical properties and molecular structure of polymers and plastics. Recently he has investigated synthetic rubbers to correlate their chemical constitution with their physical properties.

THE AMERICAN ENGINEER

“AFTER the incidence of war in Europe in the fall of 1939, we engineers were among the first to turn away from peaceful activities and to give attention to the problems of warfare in the modern style. During the two years that followed and up to Pearl Harbor, each month saw a few more of us put aside the old problems of normal life for the new ones of war. While these two years were invaluable for the initiation of developments and for the orderly building up of production, we did not during this period build up a volume of effort that corresponded to even one-fourth of our potential.

“Beginning with Pearl Harbor, however, our effort expanded at an unprecedented rate. . . . New laboratories and factories were constructed and placed in operation in time intervals measured in months. . . . We are already producing more than all Axis countries combined. While they made preparation for war their principal industry for almost fifteen years, we, with only two years of slowly increasing effort and one

year and nine months of total war effort, have already exceeded their combined maximum production rates. . . .

“From already published material the conclusion is inescapable that the functional quality of these war tools that we have developed is as uniquely outstanding as is the volume in which they have been made. . . . When the story can be told, we shall find that the American scientist and engineer, by ability not only to research and to engineer, but also to coöperate and to organize the effort from research through manufacture, have made most important and valuable contributions to implementing our warfare by the development, design and manufacture of new facilities. Progress has been made in some fields of technology in a four-year interval that, under the normal conditions of peace, would have required from ten to twenty years. . . .”

*M. J. Kelly, Director of Research,
in “The Bridge of Eta Kappa Nu,”
September, 1943.*

November 1943

Communication and Invasion

ALLIED landings on Sicily highlight the importance of proper communications in modern amphibious warfare. How crucial this element of invasion may be more fully gauged when it is recalled that United Nations troops swarmed ashore at three widely separated points: Yanks at Gela, Canadians at Pachino, and British at Augusta. In order to coordinate these three major landings, proper communications were vital.

The exact part the Signal Corps of the Army Service Forces played in the Sicilian operations cannot, as yet, be detailed. But an over-all picture of its activities in the assault upon the Italian island can be given, and we may assume that Signal Corps units operated generally in the manner outlined in the following paragraphs.

Before the start of the attack, the terrain, of course, is closely studied, and participating troops are assigned definite sectors to attack and defend. X Division, for example, part of the Task Force, is assigned the establishment of a beachhead in one particular sector of operation.

X Division includes, in addition to the usual complement of infantry, artillery and other special troops, a Division Signal Company. In that company are a radio section, a telephone and telegraph section, an intercept section, a direction-finding section, and construction, service, repair, and maintenance sections. It is their job to insure proper communications for the troops ashore.

As the amphibious Task Force approaches its objective, Naval Forces bombard the beach. Air Force bombers and strafing fighters concentrate on the same spot. As the cannonading lifts, assault troops make the initial landing. During this first phase com-



U. S. Army Signal Corps Photo

munications are short and direct. The Handie-Talkie and Walkie-Talkie radio sets enable shock troops to keep in contact with each other and with divisional headquarters aboard a ship.

The Handie-Talkie is a small, compact radio sending and receiving instrument which can be carried by a single soldier in one hand. It has a range of several miles. The Walkie-Talkie is similarly a small, compact radio sending and receiving instrument that is carried on the back of a single soldier just as a haversack is. The range of this apparatus is somewhat greater.

Visual signaling, such as flag hoists, lamps, and pyrotechnics are used by the Navy during the early phases to control landing traffic and gunfire.

Short-range radio is also used to maintain communications for air support. Air-support units are in constant contact with Air Force headquarters and enable ground troops to call for and receive tactical air support.

Depending on the tactical situation, it may be several hours or even several days before the battle enters the second phase.



Acme Photo

With American tanks rumbling past them in the valley of El Guetar and the din of battle roaring in their ears, three Signal Corps men work speedily as they establish lines of communication during the battle for Bir Marbott Pass



U. S. Army Signal Corps Photo

In constant touch with their own forces by telephone, these U. S. soldiers in the El Guetar sector of Tunisia are shown here on reconnaissance for an artillery battalion

However, when this does occur, signal communications begin to expand. Assault wire, which is a thin, light line, is laid to connect up the command posts of the various assault battalions in action.

Also, as depth is gained, use is made of the more powerful radios. One sample of this type is the vehicular radio set, which can be mounted in reconnaissance cars, half-tracks, and so forth. For use in conjunction with jeeps and other vehicles, the cavalry guidon radio set, originally made to fit into the guidon boat, is used. By this time tanks, each of which has a radio, are ashore and are pushing forward.

At the end of the second phase, with success, sufficient depth has been gained to allow regular combat operational communications to be established. The long-range mobile headquarters set is now operating for divisional and corps headquarters communications. This set has a range of several hundred miles. The light, fragile assault wire is superseded by regular field wire. A message center is established, as are radio and wire systems.

Assuming, as the invasion continues, that the mission, in addition to establishing a beachhead, is to take a town some miles inland, Signal Corps special troops have their part to play. Special combat teams race for the nerve centers of the town as soon as it is entered by our troops. Included among them are two groups of Signal Corps soldiers: a telephone team and a radio team.

The telephone team has as its job the taking over of the local telephone plant, its rehabilitation if necessary, and its operation for our own use if possible. These men have the job of utilizing existing telephone and telegraph communications, and should they not find such facilities, are responsible for putting up rapid pole-line construction for overhead wire, or of laying the special spiral-four field cable.* In most cases these wire men find it necessary to "bridge," for some of the telephone lines run out

into enemy territory. In that case, special wire crews go out and tap the line within the farthest boundaries of our own advance and connect the two taps with field wire.

The radio team has as its objective the local radio station or stations. Its job is to take over the radio station, repair it if it is damaged, and put it back on the air for the use of American forces. The radio station is used for long-distance military communications and announcements to the local populace.

The establishment of powerful radio broadcasting and receiving stations for military purposes is also part of the Signal Corps' responsibility. Ultimately our forces would have a broadcasting and receiving station for military communications powerful enough to reach the United States, London, or any of the headquarters of the United Nations.

The work of Signal Corps radio interception and direction-finding men and equip-



U. S. Army Signal Corps Photo

Entrance to a cave containing a switchboard installation for an American front line battalion during the late stages of the Tunisian campaign

*RECORD, April, 1943, p. 251.

ment deserves special mention. Signal Corps Radio Intercept teams, during the first phase, normally operate from one of the vessels of the invading fleet. Their job is to listen in on enemy traffic and turn over the information they receive to the G-2 of the force. If the messages intercepted are in enemy code, they are turned over to the cryptographic section for decoding. Last, but not least, radio interceptor units monitor our own radio communications to keep radio traffic under control and to see that military security is not compromised by our own people.

Direction-finding equipment, operated by Signal Corps personnel, goes ashore as soon as possible after the beachhead is established. Direction finding is done by two radios set as far apart as possible. By tuning in on enemy stations the Signal Corps operators are enabled to compute, through triangulation, the position of enemy communications centers. After establishing the position of an enemy station, direction-

finding signal men relay their information to artillery, which lays down a barrage at that point. The information also might be used to send out an air mission to bomb and strafe the enemy location.

Signal Corps photographers accompany each assault battalion and their mission is to take pictures from the moment of landing for military intelligence, historical, and training purposes.

Signal equipment and troops also are intimately concerned with the operations of the Air Forces. One of the first objectives in this respect is air fields.

Paratroops overrun enemy air fields after they have been bombed and strafed by American aircraft. Their means of communication is the Handie-Talkie. Among the air troops are signal troops who have the responsibility of establishing the same kind of communications as their ground force comrades—a message center, a network of radio stations, and, where necessary, complete telephone and telegraph communications.

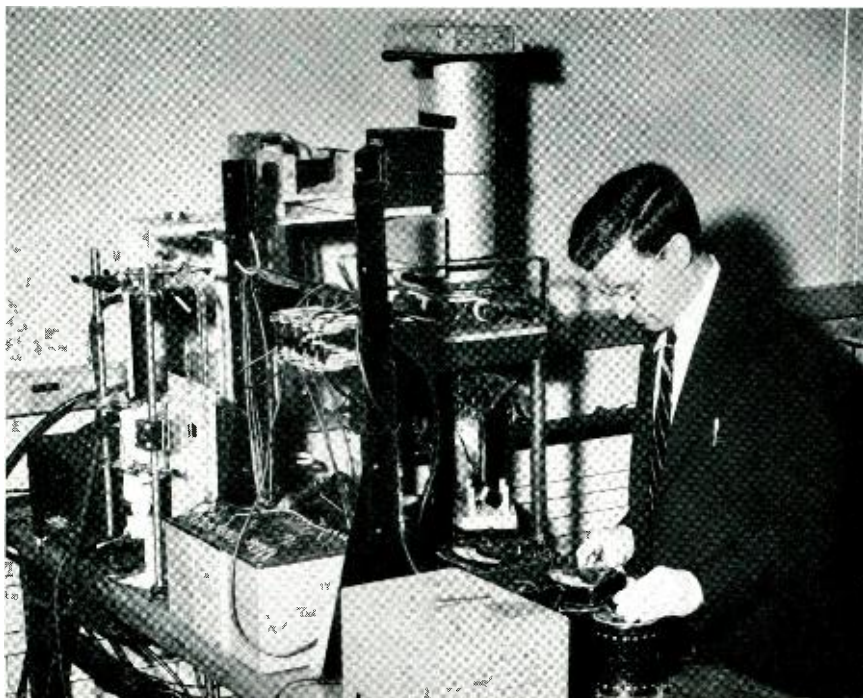

One of the laboratories in which Dr. C. J. Davisson's researches on electronics are carried out at Murray Hill. G. E. Reitter measures ionization potentials

News and Pictures of the Month

Edward Rafter of Deal Development Shop Rescues Two People

On September 13, EDWARD RAFTER, an instrument and tool maker in the Development Shop at the Deal Radio Laboratory, began his vacation. His home is on the Manasquan River, which is an ideal spot for boating and fishing. On the first day of his vacation he saved the lives of two people, an experience we in the Shop are very proud of.

As Eddie was walking along the river with his wife and a neighbor's son he heard cries coming from a row boat about 300 feet from shore. It did not take Eddie long to realize that someone in the water was in trouble. Without any regard for the danger in rescuing persons who are drowning, he stripped off his outer clothing and swam to the aid of a man and a woman.

The couple had been fishing. The man caught a fish and the woman, in an attempt to help him get it into the boat, lost her balance and fell overboard. She could not swim so the man jumped in to help her. They both became exhausted and Eddie arrived just in time to bring the woman to shore. He then returned and assisted the man who by this time was almost helpless. In the meantime Mrs. Rafter had called the First Aid Squad. Both people were taken to the hospital for treatment and later released.

When Mr. Rafter returned from his vacation L. J. SZILAGYI, on behalf of the people in the Deal Development Shop, presented him with a ship's wheel clock in recognition of his good deed.

—G. HAEGE.

New High in Bond Purchases and Payroll Deductions

During the Third War Loan drive which took place in September the Laboratories exceeded its previous highs in purchase of bonds both for cash and by authorized payroll deduction.

The Financial Department — W. C. BURGER, G. A. BRODLEY and their assist-



L. J. Szilagyi (left) and Edward Rafter of the Deal Development Shop

ants—was kept busy by Laboratories members who purchased a total of 2,456 bonds at a cost of \$180,460 and a maturity value of \$236,150. This far exceeds the previous good record made in the Second War Loan drive in April when 1,262 bonds were sold at a cost of \$91,029 and a maturity value of \$118,250.

It was in payroll deductions, however, that Laboratories members responded most loyally. During July and August both the percentage of those participating and the purchase of bonds by payroll allotment decreased sharply due in a large part to the withholding tax. On September 12, just before the Third drive started, the Laboratories as a whole had made a low with only 86 per cent participating and only 6.9 per cent of payroll going into bonds. On the tenth of October the figures were 96.6 per cent participation and 9.39 per cent of salaries and overtime payments allotted to bond purchases.

All departments contributed to this remarkable showing. The high in participation was the 100 per cent of the Legal Department and in amount of payroll deduction,

the Bureau of Publication and Library passed the goal with 10.3 per cent. Of the large departments the 98.1 per cent participation of Systems Development and the 9.97 per cent of pay of Research Department were the highs. The greatest change in position in payroll allotments was that of the General Staff Departments which went from below 6 per cent to 8.81 per cent.

These percentages were calculated by G. B. SMALL's group in the Payroll Department whose members were working extra overtime during the drive because of the thousands of cards calling for increased allotments which had to be entered and tabulated. The percentages represent the figures as of the tenth of October but do not take into account the increased payroll due to salary adjustments, effective October 1. For the month of October the Laboratories' comparison with other Bell System Companies on the basis of returns for that month will, therefore, be less favorable than these figures indicate unless many of those who have had salary readjustments promptly make corresponding increases in their allotments.

Laboratories Chapter of Telephone Pioneers Organized

On September 24, 1943, a new Chapter of the Telephone Pioneers of America, Bell Telephone Laboratories Chapter No. 54, was created and DR. F. B. JEWETT was

elected its first president. A division of the Edward J. Hall Chapter, which heretofore included A T & T and Laboratories people, had been contemplated for some time on account of the very large and rapidly increasing membership of this unit. The separation became official and Chapter 54 made its formal bow at an organization meeting of the Bell Laboratories membership in the Auditorium on the above date.

LEO MONTAMAT, previously appointed Chairman of an Organization Committee, presided at the meeting and introduced B. W. KENDALL, Chairman of a Subcommittee on Constitution and By-Laws. Following adoption of the latter, H. H. LOWRY, acting as Chairman of a Subcommittee on Nominations, presented the following slate of officers and members of the Executive Committee:

President FRANK B. JEWETT
Vice-President OLIVER F. BUCKLEY
Secretary ROY J. HEFNER
Treasurer ARTHUR O. JEHLE

Executive Committee

W. A. BOLLINGER	W. H. FREES
R. M. BURNS	R. A. HAINSLIP
J. W. FARRELL	MISS L. E. SMITH

These officers were unanimously elected and, in the absence of Dr. Jewett, the meeting was turned over to Dr. Buckley. In taking the chair, he expressed his regrets at the

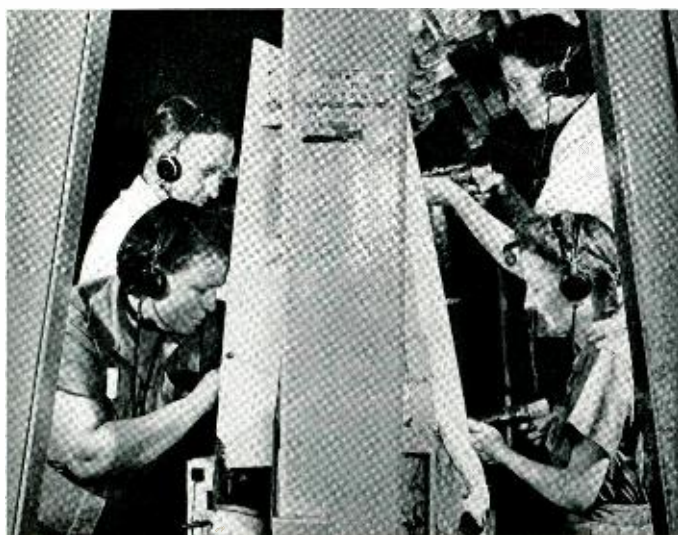

WORLD'S SHORTEST TELEPHONE LINE

Riveters and rivet-buckers at the Boeing Airplane Company, Wichita, Kansas, use Western Electric throat microphones to communicate with each other on the progress of their work. Although the riveters are only 12 inches apart, they are separated by a wall of metal through which they can communicate by no other method except a telephone

Boeing Photo

National War Fund

I ask you to give thoughtfully and generously and proportionately—remembering as you give that a share in the National War Fund is a share in winning the war, and in winning the right of free men to live in a better world.—Franklin Delano Roosevelt.

The Laboratories has been asked to help in obtaining contributions for the National War Fund. This coördinated national campaign to raise \$125,000,000 has been organ-

ized to meet the human needs of our fighting forces and of our Allies. The War Fund will be devoted to the support of the following organizations:

United Service Organizations (USO)	Norwegian Relief
United Seamen's Service	Polish War Relief
War Prisoners Aid	Queen Wilhelmina Fund
Belgian War Relief Society	Russian War Relief
British War Relief Society	United China Relief
French Relief Fund	United Czechoslovak Relief
Friends of Luxembourg	United Yugoslav Relief Fund
Greek War Relief Association	Refugee Relief Trustees
U. S. Committee for Care of European Children	

Bell Laboratories Club is conducting the campaign for contributions. Pledge cards have been distributed by the Club's War Fund Committee and representatives will personally solicit every member of the

Laboratories. Arrangements have been made whereby contributions which you make at the Laboratories will be credited to your own home community as directed on your pledge card.

I urge whole-hearted coöperation and trust that all of us will make contributions through this fund to its worthy causes.—O. E. Buckley

breaking of the ties with the Edward J. Hall Chapter, but indicated that he looked forward to the interest and enthusiasm which would be shown in the formation of the new chapter under the leadership of Dr. Jewett in his last year of active service to the Bell System.

Dr. Buckley then introduced S. T. Cushing, Secretary of the Pioneers Association, who delivered an address of welcome and expressed his best wishes for the success of the new chapter. H. E. Smith of the New Jersey Bell, Regional Vice-President of the Pioneers Association, then formally presented the charter for the new chapter which was accepted by Dr. Buckley.

Subsequent to the Organization Meeting, Dr. Jewett appointed the following standing committees to serve the chapter:

Membership Committee, R. H. Wilson,

chairman. Members representing *West Street*: W. A. Bischoff, H. W. Dippel, H. W. Everett, A. G. Jensen, A. E. Petrie, A. H. Sass, Miss Louise Van Bergen. *Graybar-Varick*: E. I. Green, J. H. Sailliard. *Davis*: H. P. Franz. *14th Street*: J. S. McDonough. *Murray Hill*: A. H. Inglis, R. C. Mathes, P. Venneman. *Whippany*: J. V. Kelly. *Holmdel and Deal*: J. C. Schelleng.

Entertainment Committee, M. B. Long, chairman, H. J. Delchamps, F. F. Farnsworth, D. D. Haggerty, E. D. Johnson, Miss C. C. Maull, Miss H. B. Mayhew, D. R. McCormack, A. A. Oswald, H. Schucht, S. W. Shiley.

Auditing Committee, H. R. Jeffcoatt, chairman, O. B. Jacobs, A. J. Snyder.

Publicity Committee, P. W. Blye, chairman, P. B. Findley, G. F. Fowler, F. J. Given, D. K. Gannett, Miss Estelle Womack.

The Secret Weapon That Will Win the War

Congress can't vote it.—

Dollars won't buy it.—

It's YOUR job to build it.—

MORALE

Be a Rumor Stopper. Rumors help the enemy. Trace the facts. Face the facts. Don't exaggerate. Make your community gossip-proof, smear-proof, panic-proof, fear-proof. Every patriot shoots a rumor dead on sight!

Meet Shortage by Sharing. Use all of everything. Don't hoard. If everybody cares enough, and everybody shares enough, everybody will have enough. No waste in your ice box, cash-box, brain-box.

Keep the Moral Standards of the Nation High. Don't weaken the home front by wangling something for yourself on the side. Dishonesty and indulgence sap the nation's fighting strength. A decent world tomorrow depends on how you live today.

On the Alert for What Telephone Subscribers Think

Within the past two or three years, a definite and scientific program of periodic or "repeat" surveys of the public's opinion of telephone service, covering all phases of attitude, has been worked out jointly by the Chief Statistician's division of the A T & T and several of the Associated Companies. These surveys keep the companies continuously informed on trends in public thinking regarding the telephone business.

Several methods are used for gathering the information from customers. Some surveys are conducted by telephone, and others on a house-to-house basis. A new approach, which seems particularly suited to wartime conditions, has been developed recently and tried out in Rochester, Minn., and Columbus, Ohio: booklets containing a number of questions were left with customers, who were asked to check off their

answers. The filled-in booklets were picked up later in the same day. Names of the persons to be contacted are selected from lists of subscribers—sometimes from the telephone directory, sometimes from directory delivery or information records—in order to get an accurate cross-section of subscribers in the area to be surveyed.

What do customers think of their telephone service in these war times, and what do they think of the telephone company? Recent opinion surveys in seven cities show a generally favorable attitude:

Eight out of ten subscribers consider their telephone service entirely satisfactory.

Most of those interviewed said the service is just as good as last year; a few said it was worse.

Nine out of ten feel that they are getting their money's worth from the telephone, and few had seriously considered doing without it.

A considerable majority think telephone rates are reasonable; that the telephone company is run economically; and that the company is doing all it can to keep down the cost of service.

The surveys also provided evidence that our customers are aware of the Bell System appeal for considerate use of the telephone by civilians in wartime. Moreover, they know the reason for this request: to enable the company to handle the flood of war calls.

When considered in the light of the difficult wartime job our people are doing, the results are a source of some satisfaction and encouragement. Much of the encouragement comes from our customers' fine spirit of sympathetic understanding of the unusual problems faced by the company in its job of providing the public with telephone service in this war period.

Signal Corps Affiliated Plan Terminated

Major General Harry C. Ingles has paid high tribute to the 5,000 Bell System men who formed the nucleus for many Signal Corps units under terms of the affiliated plan recently concluded. This plan was worked out between the Signal Corps and the telephone industry long before Pearl Harbor. Through it, nearly 5,000 Bell System employees of considerable experience volunteered for specific positions, were recommended by their companies, and were selected by the Signal Corps as qualified for those assignments. Of these men more than

3,000 became technicians and non-commissioned officers. The great majority was enrolled in specialists' groups, which provided a nucleus of skilled telephone men within many Signal Corps units, but a number of officers were assigned to staff positions or became post signal officers at army air bases.

Termination of the plan means that the Signal Corps' own training program will provide the number of experienced officers and men required in the future.

Wacs Plug for Victory on Allied Headquarters' Switchboard

An American general lifts a telephone at Allied Headquarters in the Mediterranean area and speaks: "Gypsy Lee 123." He's placing a telephone call upon which the lives and military fortunes of thousands of fighting men may depend. His manner is stern, intent. Farthest from his mind are the Broadway stage and Gypsy Rose Lee. But a smile may appear for an instant on the face of the Wac operator who took the call at the switchboard. For Gypsy Lee is the name of a telephone exchange within the network connected to Allied Headquarters.

Names of the exchanges are fantastic concoctions usually suggested by the various



Operators from the ranks of the Women's Army Corps put through calls in many languages at the Allied Headquarters' switchboard in the Mediterranean area

combat or operating units in a spirit of fun. The names are changed frequently. Some used in the past include Hot Box, Frock Coat, Auntie, Rattlesnake, Frantic, Mildew, Radish, and of course, Gypsy Lee.

You probably have read recently what a grand job the Wacs are doing overseas as telephone operators. Army men continue to heap praise upon them, and this praise confirms what Bell System people have known for a long time—that women can operate switchboards better than men.

The international switchboard at Allied Headquarters is one of the busiest, and certainly one of the most important, in the world. Since the Wacs arrived and replaced men at the board, service has improved 100 per cent, says General W. B. Smith, chief of staff at headquarters. It's an exciting and unusual switchboard, too, because it serves people who speak many different languages. The Wac operators are becoming skilled linguists. Those who were language experts before their enlistments serve as interpreters.

Most of the Wacs assigned to the Allied switchboard have had previous experience in the Bell System. Some of the others were trained on the job. They are housed in a modern city apartment building. During spare time they shop, swim, take part in a physical education program, go sight-seeing and help entertain service men at dances.

Sales and Swaps

For the convenience of members who have something they don't need, or need something they don't have, Bell Laboratories Club has set up bulletin boards at all Laboratories locations on which members may display their needs or haves. Notices must be typed on half-size sheets and carry the sponsor's name, department number and extension number.

In view of shortages in many lines of merchandise, Club members who have on hand cameras, radio sets, electrical appliances or similar articles which are serviceable are urged to make them available to others.

Each notice may be posted for two weeks, and may be reposted after a ninety-day interval. Notices should be sent to D. D. Haggerty, Executive Secretary of the Club.

Bell Laboratories Club

Harry W. Heimbach, 1886-1943

HARRY W. HEIMBACH, a former member of the Technical Staff in the Apparatus Development Department who retired in 1936 after twenty-four years of service, died on September 19.

News Notes

THE 36TH SIGNAL Construction Battalion calls itself "The Bell Battalion" because of the predominance among officers and non-coms who were Bell System men before entering the Army.

DR. MELVILLE H. MANSON has been appointed Medical Director of the American Telephone and Telegraph Company, effective November 1, succeeding Dr. C. H. Watson who retired on October 1. Dr. Manson entered the Bell System in 1940 as Medical Director of the Laboratories, and since July, 1942, has been Medical Director of the New York Telephone Company.

R. I. JONES has been appointed a member of the Non-Ferrous Metallurgical Advisory Board of the Army Ordnance Department. The function of the Board is to review and coordinate non-ferrous metal specifications

with commercial practices and experience, and to advise on other matters.

I. H. GERMER presented a paper, *Methods of Electron Diffraction*, at a symposium on *Research Tools of the Colloid Chemist* under the auspices of the Division of Colloid Chemistry, American Chemical Society.

R. M. BURNS, on September 22, gave a talk on *Corrosion Problems of Modern War* before the Pittsburgh Section of the Electrochemical Society.

AT A MEETING of the Technical Association of the Pulp and Paper Industry held in Chicago on September 23, D. A. McLEAN spoke on *Paper Problems in Telephone Apparatus*. While in Chicago he also discussed miscellaneous insulation problems with Western Electric engineers at Hawthorne.

Bell Laboratories Club

Many a newcomer to the Laboratories wonders about the Club. It isn't a secret society—you are a member of it. You became one automatically when you joined Bell Telephone Laboratories.

The Club was organized to promote athletic and social interests of members of the Laboratories. It operates the Lounge and



Archery practice on the lawn in front of the buildings at Murray Hill. Left to right: J. H. Riley, F. C. Loeber and G. E. Hanan are shooting at a target forty paces away

the Club Store for your benefit. This season it has made arrangements for the following activities:

Bowling—Wednesday and Friday evenings for men. Friday evenings for women.

Bridge—Noontimes in the Auditorium at West Street.

Chess—Noontimes in the Auditorium at West Street.

Horseshoe Pitching—Noontimes at the rear of Building T.

Rifle Club—Swiss Hall, Jersey City.

Motion Picture Camera Club—Third Wednesday at 5:45 P.M. in the Auditorium.

Orchestra—Every Friday at 5:45 P.M. in the Club Lounge.

Photographic Forum—Second Wednesday at 5:45 P.M. in the Auditorium.

Stamp Club—Luncheon meetings at 11:45 on the second and fourth Thursdays in the Conference Dining Room at West Street.

Opera Tickets—The Club has several pairs of opera tickets for the 1943-44 season in the family circle for Monday nights. For further information call Extension 1449.

The Club also sponsors several activities at Whippany, Murray Hill, Holmdel and Deal.

Officers for the 1943-44 season are:

L. P. BARTHELD, *President*

C. J. CHRISTENSEN LOUISE VAN BERGEN
First Vice-President Second Vice-President

D. D. HAGGERTY is *Executive Secretary and Treasurer* and MRS. C. A. SMITH, *Assistant Secretary and Treasurer* of the Club.

Departmental representatives on the Executive Committee are:

CATHERINE C. MAULL

Administration, Personnel and Publication

R. A. HECHT
*Apparatus
Development*

E. VAN HORN
*General Service and
Accounting*

D. A. S. HALE
Research

W. E. GRUTZNER
Systems Development

R. T. HOLCOMB
Patent Department

J. J. SHINDLE
Plant Department

Appointed members are:

E. C. WENTE
Planning

M. J. WEAN
Bowling

R. L. SHEPHERD
Publicity

MISS E. MEYERS
Whippany

F. S. MALM, in Washington, attended a meeting of the Hard Rubber Technical Committee of the Rubber Director's Office to consider the conversion of hard rubber products from natural to synthetic rubber.

R. R. WILLIAMS, C. J. CHRISTENSEN and A. N. HOLDEN were at Hawthorne on development problems of crystals.

W. O. BAKER spoke on *The Nature of the Solid State of Polymers* at a meeting of the North Jersey Section of the American Chemical Society held in Elizabeth, New Jersey, on October 11.

G. DEEG, JR., visited the General Aniline and Film Corporation at Easton with reference to plastics development.

MEMBERS OF THE LABORATORIES given in the 1943 roster of officers and committees of the Institute of Radio Engineers published in the last RECORD were taken from an advance announcement which was incomplete. In addition there are the following serving on committees:

LLOYD ESPENSCHIED, *Admissions*; J. C. SCHELLENG, *Awards*; R. A. HEISING, chairman, *Constitution and Laws*; R. A. HEISING, vice-chairman, and F. B. LLEWELLYN, *Executive*; W. H. DOHERTY, P. B. FINDLEY and J. A. MORTON, *Membership*; RALPH BOWN, *Nominations*; F. B. LLEWELLYN, chairman, H. A. AFFEL, F. W. CUNNINGHAM, F. B. FERRELL, D. K. MARTIN, G. G. MULLER and S. A. SCHELKUNOFF, *Papers*; A. A. OSWALD, *Papers Procurement*; P. B. FINDLEY, *Public Relations*; E. L. NELSON, *Registration of Engineers*; R. A. HEISING, chairman, and F. A. POLKINGHORN, *Sections*; F. B. LLEWELLYN, *Electronics*; and W. L. BOND and W. P. MASON, *Crystals*.

In addition WILLIAM WILSON (retired) represents the Institute on the *Committee of Applied Physics*; LLOYD ESPENSCHIED on the *National Advisory Council on Radio in Education, Committee on Engineering Developments*; and E. L. NELSON on the *Planning Committee, National Conference on Educational Broadcasting, American Council on Education*.

J. A. KATER spent a week at Hawthorne in connection with work on problems of condensers for government use.

C. T. WYMAN spent nine days at Hawthorne on an investigation of manufacture of networks for war projects.

GRACE CONNOR



CAPT. STEPHEN DUMA

J. F. MCCARTHY

W. H. GRAY



In the Nation's Service

William H. Gray

When WILLIAM GRAY's father picked up a morning paper recently he learned for the first time that the ship William was serving on was sunk in the Mediterranean more than two months ago.

The loss of the submarine chaser PC-496 by underwater explosions was included in the Navy announcement of six Allied warships sunk by the Axis in recent months. No news of the crew members was released, but evidently Seaman 2nd Class William H. Gray was among those saved, for his parents have been hearing from him regularly since the sinking June 6.

"Bill never so much as mentioned anything happening to his boat," his father said. "He did say he had some 'exciting and fascinating stories' to tell us, but that could have meant most anything."

Mr. Gray suspected something was up when a number of letters to his son were returned to him. Meanwhile, until official word is received, he is satisfied to know Bill is safe.

From Bill's letters, Mr. Gray thinks he is now at a land base somewhere in North Africa. "He's been telling us about going to the movies twice a week, riding camels and jackasses, and even about the time he and a few of his mates wrapped mattress covers around themselves to keep out the dust. They were mistaken for Arab women. Bill wrote that he got a good laugh out of the ex-

pressions on the faces of Arab men they passed who thought some of their women were riding in an Army truck."

The PC-496, built in 1941, and one of the largest sub-chasers, was Bill's first ship assignment. He enlisted in the Navy last February when he was 19 and went overseas in May, after training at Bainbridge, Md. A graduate of Scott High School in East Orange, he worked in the Commercial Products Development Department.

Grace Connor

GRACE CONNOR, who was a member of the first, and only, group of Waves to receive an Electrician's rating, is a Third Class Petty Officer. She was formerly of the West Street PBX. Grace lives on a reservation of three thousand women in Washington and doesn't miss civilian life a bit.

John F. McCarthy

JOHN F. MCCARTHY of the Marines had completed his boot training at Parris Island, special training at Quantico in telephony and * * * and was home on leave on the fateful December 7, 1941. He left for Pearl Harbor a few days later. After six months there he was assigned to the Solomons where he served on both Tulagi and Guadalcanal, earning his ratings the hard way. Last Christmas he was made a sergeant and given a well-earned rest. Since then Mac has seen

further action in the South Pacific, has suffered an attack of malaria, fully recovered, and is back in action where they keep him "pretty busy." He was a member of the Development Shop before enlisting in June, 1941.

Joseph A. Ceonzo

As soundman aboard a destroyer, JOSEPH A. CEONZO maintains and uses special equipment for submarine detection. "The Labs is making such equipment now," he says. "Chasing a submarine is like trying to catch a fish—refraction causes us to lose him and then we pick him up again."

Joe was aboard the destroyer that gave chase to an enemy submarine which had shot down a blimp. (*He is now taking advanced training in Illinois.*)



Charles R. Leutz hopes to be commissioned as a bomber pilot in the Marines shortly

Leonard M. Nielsen

"Greetings from Greenland! Your article on * * * in June is everything it's built up to be and a lot more. I can safely say that more than once on our way up here it saved us from tasting salt water. Since I've been here I've added quite a bit to my telephone knowledge. Working with a line crew I learned about the outside work to be done

November 1943

on lines and recently I have been moved to the central office.

"Cold weather doesn't seem to matter much. From what I gather there's a greater percentage of frost-bitten cases in Virginia than there is here. We sure are lucky, thanks to G. I. arctic equipment. Here's hoping to hear from you all very soon."

Edward J. Yastremski

EDWARD J. YASTREMSKI, a first cook at Camp Croft, S. C., came home on his first furlough recently to visit the Restaurant where he used to work.

Captain Stephen Duma

STEPHEN DUMA, a Captain in the Marine Corps, has been assigned to Virginia as * * * officer. His previous assignment was Rhode Island where he was sent upon completion of courses at the Harvard School of Electronics and at M.I.T.

Marilyn M. Pearson

MARILYN M. PEARSON, Aviation Machinist's Mate, one of forty girls in a class with three hundred men, came through seventh in the class, first among the women. Marilyn received her Third Class Petty Officer's



MARILYN M. PEARSON



Major Emil Alisch (left) is training troops at Camp Van Dorn. On a leave, he related his many assignments since he entered the service in September, 1940. He had previously been stationed in New Jersey, Louisiana, Kansas, Washington, Arizona and Georgia



Going overseas, Lieut. Col. Richard A. Devereaux stopped in at West Street to bid good-bye to his friends. Col. Devereaux had been stationed at the Anti-Aircraft Artillery School, Camp Davis, N. C.

rating in Oklahoma and has been shipped to an air field in Corpus Christi where she'll take airplane engines apart and repair them. A former draftswoman from Room 965, she visited her friends here before leaving for her new station.

Lieut. Col. Charles H. Greenall

LIEUT. COL. C. H. GREENALL has become director in charge of Frankford Arsenal Laboratory, the largest laboratory within the Ordnance Department. A few of the many projects undertaken by the laboratory since the war include work on substitute solder,

zinc base die casting, brass die casting, tough pitch copper for pressure cylinders, brass cartridge cases, steel cartridge cases for small arms and artillery, armor piercing, tracer and incendiary bullets, propellants, lubricants and solvents. In addition, research has been done on such subjects as season cracking of brass, the effects of low-melting alloys on ignition, as a part of primer development work, corrosion and finishes, and methods of physical, chemical and spectrographic testing. Development and correction of non-ferrous metallurgical specifications are handled under the general supervision of the arsenal.

Military Leaves of Absence

There were 635 members of the Laboratories on military leaves of absence as of Sept. 30.

Army 420 Waves 21 Wacs 8

Marine Corps Women's Reserve 2

Navy, Marines and Coast Guard 184

RECENT LEAVES

United States Army

Major Arnold E. Bowen	Edward J. Moskal
William C. Brossok*	Rita E. Ray
Stephen F. Lubniewski	Robert J. Seymour
Hans W. Menzel*	John P. Slickers
George J. Thiergartner	

United States Navy

William A. Beatty, Jr.	Leon P. H. Newby
Harry W. Dohlmair	Casimir J. Osiecki
Charles J. Efinger	Edith K. Ruhe
William F. Lynch	Joseph W. Wolek
Eloise Young	

United States Marines

Glen S. Bishop	Mildred E. Bourne
----------------	-------------------

*Previously on personal leaves of absence to attend Signal Corps Training School.

Lieut. Col. Raymond O. Ford

"I am still an instructor at the Command and General Staff School at Fort Leavenworth. I have just returned from a two-month trip to New Guinea and Australia where I ran across LIEUT. R. C. WINANS of the Laboratories."

Major Arnold E. Bowen

ARNOLD E. BOWEN has received his commission as a major in the Army Air Forces and has taken up his new post at Washington. Last year he did some special work with the Army in Trinidad and during the past summer he spent a month at Langley Field as a technical consultant. He holds several patents for micro-wave devices.

Joseph F. Daly

"In the last mail call I was fortunate to receive two copies of the RECORD. Needless to say, I was knocked off my feet when I read the remarks of DR. O. F. BUCKLEY on * * * in the June issue. I heard there was publication by the War Department but not to this

extent. I certainly would have enjoyed the May 17 *Telephone Hour*.

"If it would be possible I'd like to express my gratitude to members of the Labs for creating such a marvelous weapon. It has saved many a day in the past and will in the future. So I'd like to say, 'Thanks, Friends, for giving us the finest weapon to eliminate the enemy.'"

James de G. Cuyler

"MAYBE YOU MEN in 7511 thought it was hot up in the shop in summer, as I once did," says JAMES CUYLER. "But since being in the deserts of Arizona I think differently. Was with a convoy last week and we had a special ice bag hung on the radiator to keep the engine cool and an extra one to keep our feet cool. I have also been operating a portable machine shop in the desert—temperature 125 degrees in the shade."

Capt. Ernest Graunas

"It pleased me no end to hear from you and have you tell me about people with whom I've formerly worked. There are so many I'd like to know about, but I'm sure after your contact with GEORGE SCHMIDT he'll write me and tell me more. It is good news to hear that those remaining behind are doing their bit and are quite happy—they should be. Australia is nothing compared to the United States, but then there are a good many places as pleasant I'm sure.

"As to my work—I've been relieved of command of a Signal Radio Intelligence Company, having served in that capacity for over eleven months. My new assignment is in the Office of the Signal Officer, Headquarters USASOS and I work with LIEUT. COL. MISENHEIMER, also formerly of the Labs. I regret I haven't given you any technical



JAMES DE G. CUYLER

information of equipment with which I've been associated because it has been radio equipment I've worked with and not telephone. Then again, most of it is classified as secret and therefore Army Regulations don't permit its release. As for pictures, unfortunately I didn't bring a camera along—for fear of losing it and of being handicapped with excess equipment. I regret it now.

"Greetings are sent all and an urge to all to continue the fight on the home front."

Capt. William H. Lichtenberger

"My original orders assigned me directly to the Signal Corps Laboratories at Fort Monmouth on February 19, 1942, and I have been in these Laboratories ever since, except for temporary assignments at the Office of the Chief Signal Officer in Washington. I



Donald J. Oakley (left) finished his boot training and put in for gunner's mate before his recent leave. Donald visited the Blueprint Department

Traveling on troop trains as first cook is no fun. You can have Arthur Jackson's word for it. He has been to Arizona, Texas, Wyoming and California on trips recently, but he has seen very little of the countryside. Hungry soldiers give a cook no rest





EDWINA GOLDING MAJ. J. H. DEWITT

have been engaged in development and production engineering work involving most types of Signal Corps equipment. Since the latter part of February of this year I have been assigned as the Liaison Officer between all Laboratories of the Signal Corps Ground Signal Agency and the Signal Corps Standards Agency at Red Bank. My duty is to assure that all items being standardized by the latter Agency fulfill the engineering requirements for satisfactory use in ground signal equipment.

"On that score you may be interested to know that I do not feel far from the Labs because much of the work you are doing comes to my attention in one way or another and because I have met with many Bell Labs men on various projects. In every trip I have somehow met at least someone from the Bell System whom I knew. Then too, in uniform I have recurrent in-line-of-duty associations with COLONELS MORTON SULTZER and WILLIAM H. EDWARDS; MAJORS STANLEY H. LOVERING and FLOYD A. MINKS; CAPTAINS ARNOLD R. BERTELS and FREDERICK J. SKINNER; and many others from the Western Electric Company and the Operating Companies. These associations and your RECORD keep us all pretty close to home."

Margaret E. Stonebridge

"Hello Everybody: The day after I arrived at this air base at Pueblo, Colorado, I went to work as secretary to the chaplain. My job includes typing, stenography and social work (visiting the boys at the hospital).

"Just being on an Army air base makes everything very exciting. Planes are always overhead and I'm so used to their taking

off and landing now that it's just a natural drone in my ears. Regards to all."

Jesse M. Jackson

"My last visit to Murray Hill was in July of last year. I reported aboard this minesweeper shortly after and have been serving outside of the continental United States almost all of the time since. I have been in North African waters for a year.

"We have been very busy since arriving over here and probably will stay busy until our return. They say this war will be over



C. E. MERKEL J. C. STANISCI

before long. It can't be over too soon to suit me. I've been trying to get married ever since I joined the Navy, but never get enough time to do it."

* * * * *

EDWINA E. GOLDING of the Waves has has been assigned to Radcliffe College for further studies.

GEORGE J. WOLTERS of Commercial Relations was slightly injured on maneuvers in Louisiana. "I landed in the hospital (one-night stand) to get a piece of cartridge shell removed from my leg." A few days later George returned to Virginia to join his company which had left without him.

ROBERT F. FLINN is taking an eighteen-month course in electrical engineering at De Paul University.

MAJOR JOHN H. DEWITT, formerly of Whippany, was at West Street in September. Mr. DeWitt attended Officer's Basic Military Training School and is a Consultant to the office of the Chief Signal Officer.

CHARLES E. MERKEL, a member of Systems Drafting, who was on furlough recently, is in the Intelligence Section of an armored division at Camp Gordon.

ANDREW F. BARTINELLI, "Pvt. Andy of the Infantry," as he always signs himself, is still in Africa where he enjoys reading of his friends' whereabouts in the RECORD.

EUGENE L. FIELDHAMMER is studying radio at Oxford, Ohio.

JACK C. STANISCI, on leave recently, hopes to be sent to Radio School. He was attached to the utility service group under E. J. REILLY.

"ALWAYS GLAD to see a new issue of the RECORD. It's almost like going back to work for a few minutes." From JOHN K. GARDNER, an aviation cadet at Selman Field, Ia.

BERTRAND H. SOMMER was another visitor to West Street in September.

DAVID WEBSTER was at West Street on furlough from a Medical Detachment at St. Petersburg, Florida.

FRANK R. MONFORTE is at Robins Field, Warner Robins, Georgia.

HARRY VERGES, awaiting orders to be shipped from Camp Ellis, has received a first cook's rating.

JOHN H. ISLEIB received a promotion to Technician 5th Grade at Camp Hood, Texas.

EUGENE A. HULTS is in New York awaiting orders to sail.

HAROLD H. HOFFMAN believes he is going to study * * * when his training at Miami Beach ends.

"AT PRESENT I am Chief Property Accountant of a Signal Regiment at Fort Monmouth," writes FRANCIS M. HODGE. "Although it is a desk job, we must still qualify as soldiers by marching, going on bivouac, running a simulated combat course and handling weapons."

D. R. SCHEIDERMAN is stationed at Camp Santa Anita, California. He hopes to be transferred to the Air Corps.

THOMAS J. O'NEILL had returned from desert maneuvers to Fort Leonard Wood, Missouri, just before his furlough visit in September. "Tommy," as he's known throughout the West Street building, is a wireman and telephone operator in his outfit and to those duties has been added the assignment of assistant to the chaplain.

LIEUT. EVERETT C. WALSMAN is assistant to the Executive Officer of the Patuxent River Naval Air Station, Maryland.

FROM SIOUX FALLS, S. D., where he is an instructor in radio theory, F. E. TUCKER says much of the equipment used is Bell System design and W. E. Co. manufacture.

A FORMER MEMBER of the Laboratories who visited friends at 463 was LUISE WEYHENMEYER who is now in the Quartermaster branch of the Women's Marine Corps Reserve at Edenton Air Station, N. C.

"A HAPPY DAY today for I received the RECORD," writes Marine WILLIAM M. EHLER from New River, North Carolina. "It's nice to see familiar faces and read about their activities. Best wishes to G. F. DOPPEL, G. I. SIEGMAN, MISS MAYHEW and all the girls in the 4A Files."



DAVID WEBSTER

D. R. SCHEIDERMAN

ALEXANDER HOWITT is in an American hospital on a royal estate located about two hours' distant from London. British-born Al should be at home there.

HENRY H. SHARPE is on maneuvers somewhere in Tennessee.

EVELYN R. JOSD of the Waves is stationed at Potomac Park, Washington.

"I am studying at Oklahoma A. and M. College. It's the heck of a way to fight a war but the Army seems to think it best." From ARMIN J. McNAUGHTON's recent letter.



T. J. O'NEILL

LUISE WEYHENMEYER



W. R. O'Neill, a member of the Air Corps ground crew, is in Georgia. His squadron has been broken up and he has been sent north

HOME FROM Africa, WILSON TAYLOR had several campaign bars when he visited the Restaurant late in August. He lost one finger to a sniper and also suffered from shock. He is at Halloran Hospital.

LIEUT. EDWARD J. BYBEL was also a visitor to the Labs. The first man to join up from the Apparatus Development Drafting Room, he is so anxious to see active service that he transferred to a Tank Corps from the Air Corps where he was an aerologist. Mr. Bybel is now at Fort Sill, Oklahoma.



Charles E. Kempf has been transferred from Fort Monmouth to Camp Crowder and back again since his furlough visit to West Street recently

CAPT. LOUIS T. MILLER, who instructs students in B24 Liberators at Maxwell Field, claims "It's a real airplane to fly and I enjoy every minute of it."

"TRYING TO DIG a foxhole in Missouri is like digging a stone quarry with a teaspoon," according to GEORGE J. McARDLE who is at Camp Crowder.

"PLEASE CHANGE my mailing address to Allenhurst, N. J." writes LIEUT. JAMES H. MILLER. "Now that I have returned from England I hope you will substitute the regular edition RECORD in place of the 'Gypsy Rose Lee' edition."

KENNETH C. OESTREICHER has started Army aviation cadet training at Kansas State College.

HAVING COMPLETED a *** course, FINO A. PASANEN has been assigned to an aircraft warning outfit at Tampa, Fla.

ELWOOD N. RIKER has just one month to go for those silver wings and gold bars down at Greenville, Miss. "I was glad to see a picture of my old pal, JOHN H. PENNSTROM, in print recently."

Lieut. Halsey A. Frederick, Jr., is secretary to the Salvage Board for the Naval Air Material Center. Mr. Frederick was at West Street in September



"FOLLOWING A six-month stalemate at Fort Lewis, Washington, a transfer brought me to Fort McClellan where I completed a six-week course in the School of Practical Application which was little short of commando tactics." CAPT. FINAR REINBERG has been given command of a battalion. He is looking forward to a ten-day leave when he will return to the Labs to renew old acquaintances.

GREGORY CHABRA is flying a PT19 open cockpit plane at Coleman Field, Texas.

"THE OTHER day I ran into BOB SEARCH," writes ROBERT B. BURNS from Scott Field, Illinois. "You'll never guess where—in the chapel. I came in late and all but sat in his lap."

MARCELLE LESIRE flew part of the way home from Corpus Christi, Texas, where she is a Third Class Petty Officer at an air base. Her friends in Transcription enjoyed seeing her again.

THE FOLLOWING members of the Labs have also sent cards or letters to the RECORD: Thomas Fox, W. E. Thacker, R. W. Search, T. S. Diab, F. J. Schwetje, Ellis Gilliam, G. V. Smith, J. J. Emmons, R. H. Funck, F. R. Hanlon, J. R. Walsh, R. L. Norton,



Lieut. Ernest G. Graf is in Utah where he is training with the bomber crew with whom he will see action



V. J. Wycheck returned to visit his friends in the Plant Department after completing his boot and advanced training as a Navy Seabee. He is now en route to Island X.

Lt. F. W. Whiteside, A. H. Lobisser, G. F. Hall, William Flushing, George Bickard, E. J. Buckley.

Ensign W. L. French, P. E. Watts, W. R. Spenninger, H. W. Raimert, R. F. Logar, W. B. Schellerup, Paul Melkonian, S. G. Reed, A. O. Schmitz, W. C. Sylvernal, W. R. Frees, Harold Jaffe, G. E. Eltz, J. E. Young, Henry Algarin, J. J. Rosato, G. W. Galbavy, R. R. Stephens, R. H. Koehn, A. W. Schmidt, J. A. Zweig and W. F. Wilson.

“THE TELEPHONE HOUR”

(NBC, Monday Nights, 9:00 P.M., Eastern War Time)

NOVEMBER 8, 1943

Non Più Andrai from “The Marriage of Figaro” Nelson Eddy	Mozart
Melodie Orchestra	Tschaikowsky
Through the Years from “Smilin’ Through” Tower of Babel Nelson Eddy	Youmans
Carnaval Overture Orchestra	MacGimsey
The Lost Chord Nelson Eddy	Glazounoff
	Sullivan

NOVEMBER 15, 1943

Hills	LaForge
Last Night the Nightingale Woke Me Helen Traubel	Kjerulf
Cossack Dance from “Mazeppa” Orchestra	Tschaikowsky
My Bill from “Show Boat” Helen Traubel	Kern
Sextette from “Lucia di Lammermoor” Orchestra	Donizetti
Adieu Forêts from “Joan of Arc” Helen Traubel	Tschaikowsky

NOVEMBER 22, 1943

Oath of Allegiance James Melton and Chorus	Christie
Autumn Frolics from “Woodland Sketches” Orchestra	Herbert
Witness	Spiritual arr. Johnson
The Lord’s Prayer James Melton	Marlotte
Song for America Chorus and Orchestra	Sowerby

NOVEMBER 29, 1943

2nd Regiment March Orchestra	Reeves
Les Filles de Cadiz Lily Pons	Delibes
Etude in D Flat Orchestra	Liszt
I’ll Follow My Secret Heart Lily Pons	Coward
Romanza Andaluza Orchestra	Sarasate
Una Voce Poca Fa from “The Barber of Seville” Lily Pons	Rossini

Men of the Laboratories

Chosen by Lot

FELIX THIEL has always liked negotiation; back in his Scouting days he was a business manager of the newspaper published at the Jamboree in Washington. So it is natural that he should be doing a good job in smoothing out difficulties in the application of Western Electric parts to assemblies made by other manufacturers.

After high school in Worcester, Felix went to Polytechnic there, graduating in 1942. On entering the Laboratories, he was assigned to a group working on mechanical design of the gun-director. That means he hasn't had much leisure; when he does, he skates or goes to one of the Long Island beaches, or plays basket-ball. With two other men from the Laboratories, he lives in an Elmhurst apartment.

* * * * *

A LIFE STORY as strange as any Horatio Alger ever penned lies back of PAUL WRIGHT's quiet face. An orphan, his lot followed the conventional pattern until, a runaway, he was befriended by a Y.M.C.A. man in Chicago who took the fifteen-year-old lad into his own home. For eighteen



Belying his appearance, F. A. Thiel, Jr., of Switching Apparatus, is sometimes called "F.A.T."; the reason, well, you guess it!

months he formed cables for the Western Electric Company, then knocked around until, in 1924, he enlisted in the Signal Corps and became an operator and technician on radio, telegraph and cable systems. Half of his five-year "hitch" was spent in Alaska, where he assisted in the installation of radio stations.

Late in 1929 Mr. Wright joined the Mountain States company at Salt Lake City in the toll test room group and soon transferred to Long Lines as a testboard man. His interest in communication engineering led him to enroll in the University of Utah and eventually he received his B.S. degree in physics. After three years at Phoenix—1938 to 1941—he transferred to the Southern California company's



Paul Wright discusses with his associate, E. W. Holman (left), a detail of network apparatus

toll test room at Los Angeles, and eventually became a transmission and radio engineer. In June of this year he achieved his ambition—to join the Laboratories' transmission networks group. Originally working on coaxial cable equalizers, he now helps in the design and testing of military devices.

In their home in Hollis the Wrights have four children—two boys and two girls—the youngest a native daughter of New York State. As he looks them over, he is happy and proud to have provided for them the childhood security that he never knew.

* * * * *

JACK BELL knows something about the American frontier, for he has actually panned gold in a mountain stream. However, that was a summer pastime; for serious vacation employment, he chose the Mountain States company. His home town was Great Falls, Montana. On graduation from the University of Colorado in 1939—B.S. in E.E.—he went to work for Mountain States in their plant organization. Last June he transferred to the Laboratories; here in the trial installation group he is engaged in engineering work in connection with the design and construction of facilities for the Armed Forces of the United States.

Just after he graduated, Jack married his roommate's sister. Coming to New York was a great experience for both of them; from

the Empire State Building and the sight-seeing yacht and the bus top they saw all the places they had read about. With their daughter, Judy, they live in Baldwin.

* * * * *

AT THE POINT BREEZE PLANT of the Western Electric Company H. H. GLENN, C. A. WEBBER and D. R. BROBST discussed substitutes for rubber insulation.



J. W. Bell is in the trial installation group of the Equipment Development Department

During August and September the United States Patent Office Issued Patents on Applications Previously Filed by These Members of the Laboratories

H. H. Abbott	R. D. Fracassi	R. F. Mallina (2)	W. T. Rea (2)
L. G. Abraham	H. W. Goff (2)	C. O. Mallinckrodt	J. B. Retallack
H. M. Bascom	N. I. Hall	W. H. Martin	L. J. Scott
W. S. Bishop	L. N. Hampton	H. E. Marting	A. H. Shangle
N. W. Bryant	H. C. Harrison	A. S. Martins	H. S. Shope
H. T. Budenbom	H. A. Henning	W. P. Mason	A. M. Skellett
R. K. Bullington	W. H. T. Holden	B. McKim	G. G. Smith
C. J. Christensen (2)	A. L. Hopper	L. A. Meacham	A. G. Souden
F. S. Corso	A. W. Horton, Jr.	J. M. Melick	H. H. Spencer
S. I. Cory	F. A. Hubbard	M. E. Mohr	H. M. Stoller
A. C. Dickieson	W. F. Ingerson (2)	C. M. Morris	H. F. Stover
T. L. Dimond	S. B. Ingram	E. R. Morton	S. M. Sutton
J. T. Dixon	R. C. Johnson	G. E. Mueller	C. H. Trenkle
T. L. Dowey	D. H. King	P. Neill	D. E. Trucksess
K. S. Dunlap	C. D. Koehling	D. B. Parkinson	H. W. Ulrich
L. L. Eagon	F. R. Lamberty	R. L. Peek, Jr.	K. G. VanWynen
P. G. Edwards (3)	B. F. Lewis	K. W. Pflieger	E. F. Watson
W. C. Ellis	J. B. Little	C. E. Pollard, Jr.	C. H. Young
E. L. Erwin	C. A. Lovell (4)		W. R. Young, Jr.

Members of Bell System Companies Transferred to the Laboratories to Aid in War Work—April 1, 1943, to October 1, 1943

A. T. & T.

C. L. Cahill.....3400	G. J. Heinzelman...3400
G. T. Coker.....1700	C. P. Maine.....1700
J. H. Durrett.....1700	F. W. Mayo.....3200
W. H. Goodell.....3600	O. D. Schmidt.....1700
Alvin Hecker.....3200	E. F. Schuster.....3500



J. G. Braybrook Miss Stephan C. H. Fasse

New York Tel.

E. C. Amrhein.....3600	E. J. Keiper.....3500
G. T. Anderson.....3200	S. C. King.....3200
C. E. Barker.....2100	J. F. Kraus.....1700
G. J. Bennett.....2600	E. F. Leach.....3200
J. H. Bigelow.....6200	F. A. Lindeberg.....2600
E. F. Billman.....2400	A. L. Loh.....3200
A. E. Blackman.....1700	L. V. Matzuga.....2100
W. L. Bridges.....7400	R. C. Miles.....2200
H. B. Button.....3200	H. A. Milmoie.....6100
D. M. Castagna.....7200	J. P. Mortensen.....3600
T. W. Chisholm.....3600	W. E. Nicholson.....2100
G. J. Christ.....3100	J. W. Nordstrom.....7400
V. K. Concannon.....2100	Leo Novak.....1700
D. S. Dewire.....3600	D. C. Osborne.....3200
R. L. Dickinson.....7400	A. D. Petterson.....2400
H. F. DuBois.....7100	F. J. G. Schebler.....7400
W. R. DuVernet.....2200	J. M. Seaman.....2600
H. I. Emery.....2600	C. J. Smith.....3200
C. G. Graf.....2100	Martin Sorensen.....3200
D. E. Haight.....2200	Christine Stephan.....6200
C. M. Hanley.....3200	H. J. Theiling.....3200
J. R. Hendl.....7400	R. W. Ulmer.....3100
H. B. Hengerer.....2600	A. E. Valentine.....6200
A. J. Hyatt.....7400	S. M. Wikel.....2600
J. G. Jonassen.....2200	L. S. Youngling.....7500

Michigan Bell

J. G. Braybrook...3200

Pacific Tel.

O. M. Akey.....3400
E. L. Blanchard.....2400
W. G. Collins.....1700
K. H. Haber.....1100
G. B. Lake.....1700
W. S. Neville.....3500
I. P. Price.....1700
J. M. Roberts.....2100

New Jersey Bell

N. K. Balderston...3600
E. W. Borden.....3400
S. B. Coleman.....3600
C. E. Foss.....3100
A. B. Horgan.....3400

Cincinnati & Suburban

C. H. Fasse.....7500
F. A. Wahle.....3200
C. E. Whitney.....3200

Chesapeake & Potomac

A. N. Feelemyer...3200	T. A. O'Halloran...3200
H. P. Kelly.....3500	M. L. Peipon.....3200
H. W. King.....3100	M. F. Rheinhardt...2100
F. L. McNair.....2200	E. R. Seim.....2100
G. C. Wilson.....1700	

Illinois Bell

A. M. DeRose.....3200	V. E. Lowden.....1100
S. L. Eppel.....3100	H. D. Magnuson...1700
F. B. Henderson...1400	G. L. Martin.....1700
J. F. Jirousek.....3200	M. J. Van Weelden...3200
W. T. Larner.....3200	F. G. Varenhorst...1700
B. R. Wohld.....1700	

Mountain States

J. W. Bell.....3200	Abe Maiman.....1100
R. V. Dean.....3400	E. J. Noon.....3200
W. W. Dieter.....1700	Conrad Sikes.....1700
R. B. Hannah.....1700	H. J. Strelesky...3200
G. G. Thomas.....2400	

Western Electric

C. B. Brown.....2200	H. J. Kostkos.....6600
Gilbert Goodman...1200	J. T. Muller.....1700
F. J. Grattan.....3500	Emil Munger.....3500
Stephanie Jacewiuk...7100	J. I. Politzer.....3200
R. E. Keim.....3500	H. L. Smith.....3500
R. L. Vance.....1400	

Southern New England

D. B. Henderson...3200
W. A. Shaw.....3200

Bell of Pa.

E. F. Doubs.....3200

Southwestern Bell

L. L. Burns.....3400
J. N. Cosby.....1700
E. A. Hegar.....1700
F. R. Small.....1700
A. D. Yarbrough...2100

Southern California

R. J. Foulke.....2200
C. E. Pierce.....3200
P. B. Wright.....2100

Northwestern Bell

F. O. Bernard.....3400
B. C. Nourse.....3600

Ohio Bell

G. R. Frost.....3600
H. R. Garing.....3600
C. E. Miller.....2200
H. C. Smith.....2500



A. D. Yarbrough H. P. Kelly R. L. Dickinson

- 1100 Physical Research (H. Fletcher)
- 1200 Chemical Laboratories (R. R. Williams)
- 1400 Electronics Research (J. R. Wilson)
- 1700 Commercial Products (O. M. Glunt)
- 2100 Transmission Apparatus (R. G. McCurdy)
- 2200 Switching Apparatus (H. A. Frederick)
- 2400 Station Apparatus (W. H. Martin)
- 2500 Quality Assurance (G. D. Edwards)
- 2600 Apparatus Staff (H. S. Sheppard)
- 3100 Switching Engineering (H. M. Bascom)

- 3200 Equipment Development (H. H. Lowry)
- 3400 Transmission Engineering (R. K. Potter)
- 3500 Transmission Development (D. A. Quarles)
- 3600 Systems Administration (M. Sultzer*)
- 6000 Personnel (G. B. Thomas)
- 6500 Bureau of Publication (John Mills)
- 7100 General Accounting (A. O. Jehle)
- 7400 Commercial Relations (B. B. Webb)
- 7500 Plant (S. H. Willard)

*On Military Leave of Absence.

FLORIDA COMFORT
G. T. Ford was presented with this air-conditioning system—à la Rube Goldberg—at his recent retirement dinner. A. G. Jeffery, who designed and produced the system, is shown explaining the system to Mr. Ford

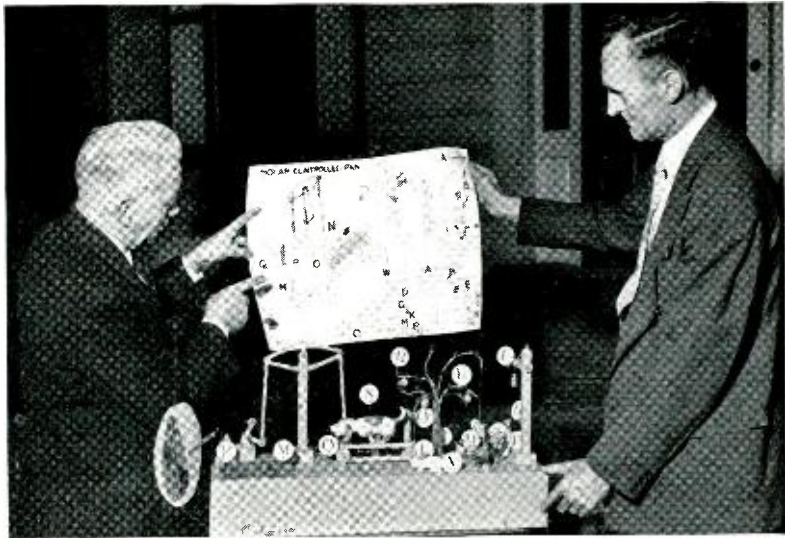

Army Public Telephone Service

LATEST FIGURES showing the extent to which attended public telephone service and full-time camp manager representation are being provided to meet the needs of the armed forces show that the number of attended locations has increased from 253 to 280 and the number of camp managers from 212 to 239. Plans call for 131 more attended locations and 69 more managers.

October Retirements

R. S. Wilbur

R. S. WILBUR, Switching Development Engineer of Systems Development, was retired on October 31 at his own request with a Class A pension upon completion of over thirty-three years of service. Mr. Wilbur's telephone experience began in the independent field in 1899 and, during the ensuing eleven years, he worked for several operating and manufacturing companies in Ohio and for the Schenectady Home Telephone Company and Albany Home Telephone Company in New York. Coming to the Western Electric



R. S. WILBUR

Company in 1910, he entered the Circuit Laboratory and engaged in miscellaneous circuit design work, particularly in connection with the development of telephone repeaters. Later, he turned to the development of circuits involved in toll switchboards, test boards and signaling systems for standard use in the telephone plant, and in 1919 was placed in charge of the toll switchboard group. A year later he was one of a commission that went to Havana to make a survey to determine the requirements for a telephone cable system between Key West and Havana where his concern was with particular reference to the switchboard required for the operation of such a system. When this cable was installed in 1921 he was concerned with the testing of the switchboard circuits during installation.

Since 1922, first as Toll Circuit Engineer and more recently as Switching Development Engineer, Mr. Wilbur has been responsible for important improvements in toll signaling and switching; notable among these have been the general introduction of

During 1942 the Bell System re-used 9,000,000 pounds of copper line wire for making essential additions to long distance circuits. Currently the System's entire needs for this type of wire are being met without using new stocks.

voice-frequency ringing methods, the development of the No. 3 toll switchboard, the No. 5 toll test board and the No. 8 test and control board, signaling and control circuits in connecting wire lines to radio circuits, toll line dialing, a-c key pulsing and important aspects of the No. 4 toll crossbar system recently placed in operation in Philadelphia.

A. C. Magrath

A. C. MAGRATH of the Switching Apparatus Development Department retired on



A. C. MAGRATH

October 24 with a Class A pension following a year of absence due to sickness. He joined the Drafting Department of the Western Electric Company in 1900 and two years later left to complete his studies at Pratt Institute, subsequently engaging in the design of tools and machinery for other concerns. In 1910 he rejoined the Western Electric Company and after two years of drafting became a member of the newly formed Dial Apparatus Group where he was concerned with design work on switching mechanisms.

During World War I Mr. Magrath was engaged in the design of radio equipment and in 1919 returned to the development of switching mechanisms. Since then he had done extensive design work on both step-by-step and crossbar switching apparatus and was also largely responsible for the design of the 51-type dial tester. In this connection a number of patents have been issued in his name. More recently Mr. Magrath was associated with several war projects.

F. G. C. Volkert

FRED G. C. VOLKERT of the Equipment Development Department retired on Oc-



F. G. C. VOLKERT

tober 31 at his own request with a Class A pension upon completion of thirty-nine years of service in the Bell System. Mr. Volkert joined the Installation Department of the Western Electric Company in 1904 and shortly thereafter entered the Engineering Department to engage in power engineering and order editing. Later he took charge of the order editing division, which was transferred

October Services Anniversaries of Members of the Laboratories*

<p>10 Years</p> <p>T. F. Rogan</p>	<p>R. H. Ross</p> <p>F. J. Scaccia</p> <p>J. J. Scanlon</p> <p>R. R. Scoville</p> <p>W. J. Szmekal</p> <p>W. A. Tracy</p> <p>H. E. Vaughan</p> <p>J. W. Wolek</p>	<p>Mary Koncelik</p> <p>E. A. Krauth</p> <p>J. A. Kreck</p> <p>Andres Llorente</p> <p>Frank McFadd</p> <p>W. J. Means</p> <p>J. D. Sarros</p> <p>E. S. Savage</p>	<p>C. C. Munro</p> <p>C. D. Richard</p>
<p>15 Years</p> <p>Virginia Ahearn</p> <p>F. M. Burelbach</p> <p>R. L. Conklin</p> <p>Harry Hansen</p> <p>A. H. Hearn</p> <p>W. F. Hoover</p> <p>E. H. Jones</p> <p>Arthur Ludwig</p> <p>S. N. Markocki</p> <p>W. H. McAuliffe</p> <p>J. A. McHugh</p>	<p>20 Years</p> <p>Aniello Arcella</p> <p>G. E. Atkins</p> <p>I. H. Baker</p> <p>L. J. Barker</p> <p>T. J. Broder</p> <p>C. W. Carter, Jr.</p> <p>F. A. Hoyt</p>	<p>25 Years</p> <p>Anna Dahlman</p> <p>Mary Farmer</p> <p>R. J. Heffner</p> <p>Kathryn Joyce</p> <p>Barton Koopman</p> <p>Morris Le Boff</p>	<p>30 Years</p> <p>G. D. Edwards</p> <p>J. D. Hubbell, Jr.</p> <p>R. E. Ottman</p> <p>L. W. Parker</p>
			<p>35 Years</p> <p>G. A. Locke</p> <p>A. H. Sass</p>
			<p>40 Years</p> <p>C. H. Berry</p> <p>George Dodd</p>

*Biographies of 25-year people that have not as yet appeared will be published in future RECORDS.

as a unit successively to the Commercial Engineering Department and the General Sales Department. Transferring to the Foreign Sales Department, he became responsible for editing foreign orders and handled special assignments for the executive staff. In 1911 he went to Montreal to supervise the power division of the Equipment Engineering Department of the Northern Electric and Manufacturing Company.

On returning to New York in 1919 Mr. Volkert joined the Systems Development Department, with which he has since been associated. For some time he had charge of the preparation of recommendations and specifications for power plants to be used with step-by-step equipment. He also handled the development and standardization of the automatic power plants for 700C PBX equipment. In 1925 he was placed in charge of the special equipment engineering group which handles analyzation questions relating to power plant equipment, providing the telephone companies and Western Electric with recommendations on orders to which standard equipment is not applicable. Recently Mr. Volkert had been concerned with special projects for the Signal Corps.

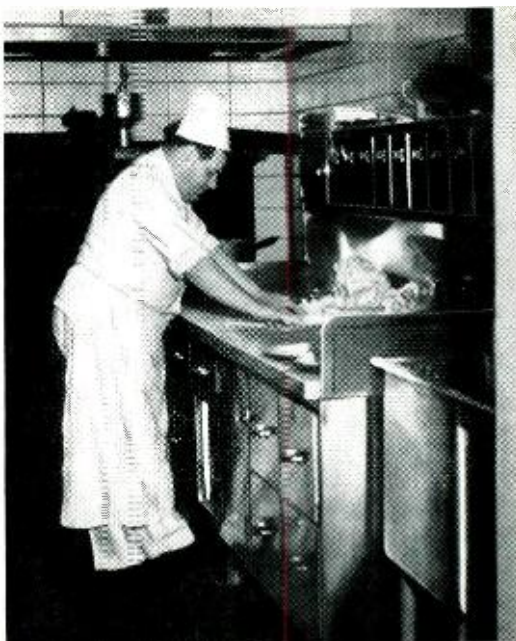

If you are at Murray Hill, you know Charlie Erb's pies, made in this Pastry Kitchen

AT HAWTHORNE, C. T. GRANT and N. INSLEY discussed crystal units; D. R. BROBST and W. A. BUNZEL, network manufacturing problems; and C. A. WEBBER, cable and wire.

R. T. STAPLES, in Boston, conferred on the manufacture of some special cable.

H. H. STAEBNER went to Washington on the development of special cables.

C. S. KNOWLTON and E. F. HELBING visited the Leland Electric Company at Dayton and the General Electric Company at Fort Wayne in connection with rotary machinery.

F. B. CAVE was at the Patent Office in Washington during September relative to patent matters.

THE LABORATORIES were represented in interference proceedings at the Patent Office in Richmond by Miss C. MATTICE before the Board of Interference Examiners and by R. O. COVELL before the Primary Examiner.



Service pantry at Murray Hill. Mrs. A. Force and O. Mohni preparing tomorrow's luncheon

Women of the Laboratories



LOUISE R. CARBONE

BORN AND RAISED on a farm in Moonachie, New Jersey, LOUISE CARBONE still loves that life. After a hectic week in the Payroll Department she turns for relaxation to the pastime she shares with her husband—raising prize stock rabbits. At her home in Little Ferry she has one hundred Flemish Giants and white New Zealand Does which she sells for breeding purposes and for laboratory specimens. Her pet is a red buck rabbit, the pedigreed GENERAL MACARTHUR, who weighs eighteen pounds and has won three blue ribbons. This year she also helped raise a Victory Garden and divided her vacation between working on it and helping to pick tomatoes on her husband's farm. Some day she hopes to own a stock farm and raise animals.

Louise, a graduate of Ridge-

field Park High School, came to the Laboratories as a messenger in 1936. She was transferred to Payroll where she now works at Fourteenth Street on social security taxes and their adjustments for members of the Laboratories on monthly payroll. She determines when to stop collecting the tax from those who have passed the three thousand dollar mark; assists in the preparation of state unemployment insurance reports; and prepares social security statements for employees leaving the company.

* * * * *

ADELINE GORDON wears the overseas campaign ribbon of her husband, a Navy Seabee now in Trinidad. While he does his part to win the war, she does hers by buying bonds, by writing to him daily and by doing essential work in the Development Shop of the Laboratories. Recently she accomplished a task of which she is justly proud. Operating a power press for the first time, she punched out approximately eight thousand contacts daily for step-by-step switchboard terminals needed in a telephone experiment. The work consisted of three operations—inserting the



ADELINE GORDON

guide pins, swedging and punching out the terminals. She did an accurate, speedy job with little shrinkage.

The Gordons have two children, Margaret who is ten, and William, seven. Adeline spends most of her spare time with her family. She has recently joined the Bell Laboratories Bowling Club.

* * * * *

DRAFTING is part work and part school for girls like JOAN CURTIS of the Research Staff Department. Joan joined the Laboratories in 1942 and, after being a messenger for three months, was accepted as a student for a full-time six-week introductory drafting course given by the Personnel Department. Upon its completion she was assigned to her present position where she works at a drafting board all but five hours a week—those five hours being spent in advanced part-time training. She is now studying drafting, computations and engineering materials in the second of three sixteen-week terms. Her picture was taken at the blackboard in a classroom at Fourteenth Street where she was reviewing a rotated section and a removed section.

Joan lives in Old Town, Staten Island, with her mother, brother and her father, C. F. CAMPAGNA, who is a draftsman in the Davis building. Her mother and grandmother taught her to sew and to cook—she makes some of her own clothes and used to specialize in butter cookies in days before butter was sixteen points a pound. Roller skating and collecting popular records are her hobbies—Harry James and Frankie Carle's piano recordings are her favorites.

SHIRLEY GRIMM, a graduate of Dickinson High School and New York Preparatory School, worked at Western Electric for six months before transferring to the Laboratories where she is in the Development Projects and Service group of the Commercial Relations Department. For fourteen years she has been a member of this group, first in the Research and then in the Central Service Department. Her work includes typing in the required forms the various types of orders that come to the department, recording their costs and the time of their completion, and maintaining an active file of shop orders together with their drawings, as well as the file of engineers' sketches. She also maintains a monthly record of work sent to the Development Shop and receives requests for "long" and "short" order work.

Miss Grimm spends some of her weekends aboard an ex-Coast Guard yacht, the

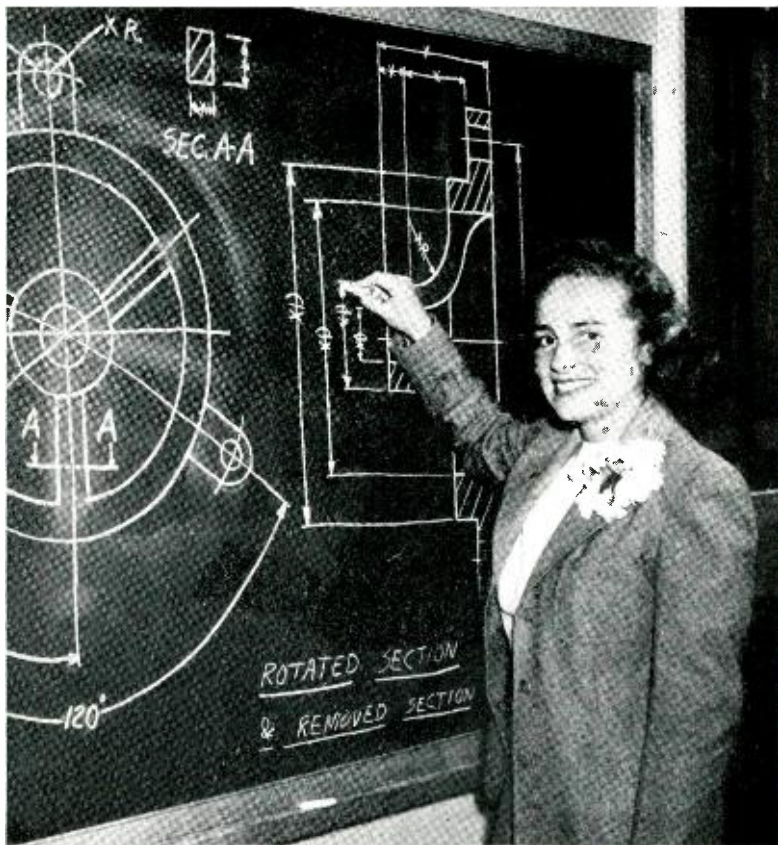

Joan Curtis takes advanced part-time drafting training in the classrooms provided at Fourteenth Street



SHIRLEY A. GRIMM

Ayana. With sailing her first choice as an avocation, fishing, naturally, follows as her second, and swimming her third choice. Over those week-ends when the boat is in

dock she becomes a dry-land sailor who is as familiar with ship routines there as she is in the deep. With the women aboard the *Ayana* she has learned to prepare a meal, but claims no talents as a cook. Her winter-time hobbies are ice skating and sleigh riding.

Christmas Kits for Servicemen Overseas

Filling kits for servicemen overseas gave a great deal of pleasure to one hundred and fifty girls at West Street. The contents of each kit was selected by the girl who filled it. Many of the gifts were wrapped in Christmas paper, and included, besides the usual practical items, were such things as tins of candy, dried fruit, nuts, tobacco, books, novelty writing paper and pipes. The kits were donated by the Red Cross and distributed under the direction of MARY REDDINGTON, who is chairman of the committee. She was assisted by EVELYN FITZSIMMONS, HELEN HOAR, GERTRUDE KEININGHAM, DOROTHY KOVELL, NANCY MARTIN, HELEN MAYHEW, HILDA MULLER, MAR-



These are members of the Red Cross Christmas Kit Committee for Servicemen Overseas, with some of the one hundred and fifty kits filled by girls at West Street. Left to right: Hilda Muller, Nellie Schofield, Nancy Martin, Evelyn Fitzsimmons, Dorothy Kovell, Helen Mayhew, Margaret Reen, Mary Reddington, Gertrude Keiningham



JESSIE B. MCGOWAN

GARET REEN and NELLIE SCHOFIELD. Due to the shortness of time it was not possible to distribute the kits for filling outside of West Street. It is hoped that the project will be Laboratories-wide next year.

* * * * *

IT IS RARE to find among girl technical assistants one who has the knack for using and understanding the wide variety of measuring circuits which electrical engineers use. Such circuits are loss circuits, impedance bridges, and phone circuits. JESSIE MCGOWAN has that knack. She was originally interested in medicine, had started pre-medical work, and was on the way to become a doctor. The war changed all that. She has switched her course at New York University and expects to work for a degree in electrical engineering. A member of Apparatus Development, she is in the filter and crystal group where she does general laboratory work, makes measurements of electrical networks and assists the engineers on confidential war work.

Miss McGowan is a graduate of Walton High School in the Bronx where she lives with her parents. Her brother is in the Navy.

She has been a member of the Laboratories for over a year, having spent five months "on the mail" before her promotion to technical assistant. Her favorite recreation is a toss-up between the theater and books—at graduation she wrote and directed the class play at Walton High; her collection of books has reached the five hundred mark.

* * * * *

GROWING UP in a family of ten children taught JOANNA FAUROSS the art of "give and take," with emphasis on the giving. This training stands her in good stead at the Whippany Laboratories where she is a member of the Operations and Maintenance group. Her many duties include the care of



JOANNA B. FAUROSS



Here are some of the 3,000 toys which members of Bell Laboratories gave to needy children last Christmas. The children of many servicemen and seamen will be among those who will be benefited by your generosity this year

special passes at that location, the assignment of lockers, the maintenance of records of gasoline consumption at Whippany and the duties of cashier in the restaurant in emergencies. She sees that the cars are out of the garage in the morning and back in again at night, helps to get them gassed, and sometimes meets visitors at the Morristown station. She also assists in the sorting and delivery of the payroll and of time cards.

Joanna has a younger sister at that location and two brothers in the Army; the other members of her family are married. Her likes include jive, popular music, people in general and Bing Crosby in particular. She finds time to report once every two weeks to her local Office of Civilian Defense where she does clerical work.

The Doll and Toy Committee Asks Your Support

Christmas comes to children in spite of economic conditions, and somehow in the face of the international situation the feeling this year seems to be "We'll give them a better Christmas than ever." And so the 1943 Doll and Toy Committee under the

chairmanship of MARY-ELLEN BAGLEY is already at work to make their annual contribution to some fifty odd charitable institutions in the metropolitan area. You remember the splendid showing last year of \$1,250 which bought over 3,000 items. Let's do it again, and if your departmental representative has not already approached you, she will. Give her your contribution for the children.

New Jersey locations have established their own organization, with headquarters at Murray Hill, and their returns will go to welfare groups in their own areas.

Junk Jewelry Wanted

Your *junk* jewelry is worth more than its weight in gold. Your husband, fiancé or brother in service needs it for wampum in bartering with natives in the South Pacific—and he needs it now. For that tarnished gold pin of yours, or the bracelet with a stone missing, a native will gleefully dig a foxhole, or carry a wounded man back from the front lines. An instance of a man's digging fifty foxholes for a necklace has been reported.

You can do your part to help your fighting men by cleaning out jewelry boxes and dresser drawers for faded strings of beads, old



"—and I thought that costume jewelry was sure fire"

Departmental Representatives for the Doll and Toy Committee

Mary-Ellen Bagley..... <i>Chairman</i>	Helen C. Mockler.....	}3100, 3300, 3500, 3600	Mable Sleght.....6000
Charlotte M. Brotzfield. 110, 210	Mildred M. Ralph.....	}3200	Mary L. Reddington....6500
Nellie Schofield..... <i>Research</i>	Catherine Cronin.....	}3200	Louise Van Bergen.....7000
Jean E. Davis.....	Margaret R Emmelman.....	}Drafting	Ruth Schneider.....
Elvira Lang.....	Violet Stahland.....	}Rooms	}Graybar- Varick
Louise Van Bergen.....2500	Agnes C. Hirsch.....		Ada I. Van Riper.....Davis
Bernice J. Potwin.....	Helen Findley.....		Marie G. Wright.....
Henrietta M. Purkrabek}	Rosemary T. Kennedy..	}3400	}Murray Dorothy Storm.....}Hill
	Constance D. Roke....	}5000	

rings, valueless buttons and earrings, and the like. Bring them to the Laboratories, and put them in the mail in a sealed envelope, addressed to R. C. FISHER, Room 131-A, West Street. The jewelry will be packed and sent off to the South Pacific.

This appeal, while primarily for the girls of the Laboratories, is also meant for the men. During the past five years they have bought for their families and friends most of the jewelry sold in the Club Store. They will help the drive by passing the word along to their womenfolk and by bringing in the discarded jewelry collected at home.



Do You Eat a Nourishing Lunch?

A "sandwich and —" is not an adequate lunch. At noon your meal should supply up to one-third of the day's required calories. When you do eat a well-balanced luncheon, you'll plunge into the afternoon's work with vigor. Those late afternoon jitters will disappear; you'll be more efficient; and you'll be able to work through the day with less fatigue. Try eating a good lunch and see!

News Notes

W. E. CAMPBELL attended a meeting of the subcommittee on Friction Lubrication and Wear of the National Advisory Committee on Aeronautics in Pittsburgh on September 15. While there he also discussed

corrosion problems with engineers of the Aluminum Company of America.

V. T. WALLDER was at the Frankford Arsenal in Philadelphia to discuss the conversion from natural to synthetic rubber for cable insulation.

C. J. FROSCHE spent some time at Hawthorne in discussions of plastics.

R. A. HEISING, W. P. MASON and W. L. BOND were at Hawthorne and at Cleveland during the latter part of September. R. A. SYKES also went to Hawthorne.

B. S. BIGGS and R. H. ERICKSON presented a paper entitled *A Method for Determination of Plasticizer Content of Cellulose Esters* before the Pittsburgh meeting of the American Chemical Society.

W. L. BETTS has been appointed Chairman of the Program Committee of the Metropolitan Section of the A.S.M.E. for the 1943-1944 season.

Engagements

Eng. Pierce A. Cassidy, U. S. Navy—*Corinne Steers
 *William A. Hoefener—Irene Koelling
 *Harry C. Meier, U. S. Army—Dorothy Swartz
 Charles G. Schmitz—*Jean Davis
 Lt. Kenneth Steen, U. S. Navy—*Frances Preston
 Henry Tew—*Elizabeth Carl
 *Stuart R. White—Lucy Young

Weddings

*Carl G. Braun—Virginia Wittenberg
 Lt. George H. Dietz, U. S. Army—*Elizabeth Churchill
 *Herbert H. Koehn—*Anna Mills
 *Ernest T. Lundgren—Dorette Bernasconi
 John F. Sconhoft, U. S. M. C.—*Mabel Gatehouse
 *Vincent Wycheck, U. S. Navy—*Patricia Beattie

*Members of the Laboratories. Notices of engagements and weddings should be sent to Mrs. Helen McLoughlin, Associate News Editor, Room 1103.

R. H. COLLEY and G. Q. LUMSDEN were in New Haven and Forestville, Conn., in connection with the studies, conducted jointly by The Southern New England Telephone Company and the Laboratories, on poles treated full length with preservative salts under pressure and butt treated with creosote.

I. G. ABRAHAM, J. A. CARR and R. J. NOSSAMAN worked with the Signal Corps Board at Fort Monmouth on a manual on *Open-Wire Line Construction*.

H. T. LANGABEER and A. J. WIER, with representatives of the A T & T Company and Western Electric Company, visited the Dallas-San Antonio and Chicago-Terre Haute K2 carrier installations. Mr. Langabeer also visited several of the auxiliary carrier repeater stations between Dallas and Waco, Texas, and the auxiliary station at Waco.

The 1943-1944 Roster of committees of the American Institute of Electrical Engineers includes the following members of the Laboratories: H. M. TRUEBLOOD, *Board of Examiners*; R. L. JONES, *Constitution and By-Laws, Standards*; O. F. BUCKLEY, chairman, *Charles LeGeyt Fortescue Fellowship*; O. B. BLACKWELL, *Lamme Medal*; F. G. D. PATERSON, *Membership*; H. A. AFFEL, *Award of Institute Prizes*; JOHN MILLS, *Publication*; M. J. KELLY, *Research*; J. D. TEBO, secretary, and M. J. KELLY, *Basic Sciences*; H. A. AFFEL, chairman, JOHN DAVIDSON, JR., S. B. INGRAM and R. G. McCURDY, *Communication*; G. B. THOMAS, *Education*; S. B. INGRAM, chairman, *Elec-*

Thus far in World War II more than one-third of all the electronic and communications equipment produced in the United States for the armed forces has come from the assembly lines of the Western Electric Company.



WHAT'S THE GAG?

Just a reminder that silence, where your work is concerned, will help win the war—sooner!

GUARD YOUR SPEECH

tronics; F. I. GREEN, secretary, *Committee on Instruments and Measurements*.

J. M. WOODARD discussed possible changes and additions in the Chicago toll office while on a recent trip to that city.

W. C. F. FARNELL and H. J. KOSTKOS visited the "Back the Attack" Army Show in Washington. Mr. Farnell, stopping at Philadelphia on his return, visited The Franklin Institute Museum and The Bell Telephone Company of Pennsylvania.

C. D. HANSCOM, as a member of the special subgroup of the A.S.A. Sectional Committee on Standards for Graphic Presentation, was the author of an article, *New Standard Aids Legibility in Engineering Graphs*, published in the September issue of *Industrial Standardization*.

C. T. MILLER discussed motor problems at the Speedway Manufacturing Company, Cicero, Ill., and the Dumore Company, Racine, Wis.

MOTOR driven blower units were the reason for F. F. SIEBERT's recent visit to the American Blower Corporation, Detroit.

We See by the Papers, that

The operational calculus is associated particularly with the names of Oliver Heaviside, T. J. I'A. Bromwich, and J. R. CARSON. . . . By means of an equation Carson set up a correspondence between $f(t)$, a given function of the time, and its operational representation or symbolic image $\phi(p)$. From this he derived a set of theorems of the utmost importance in operational calculus and in the solution of electrical problems. . . . —*Nature, London, July 24, 1943.*

[For many years prior to his death in 1940, Dr. Carson was a member of the Laboratories.—EDITOR.]

According to an article by C. H. PRES-COTT (*BELL LAB. REC.*, 21, No. 4; Dec., 1942), the solubilities in mercury of silver,



BLOOD DONORS

From the Murray Hill Laboratory

- | | |
|---------------------|-----------------|
| Jean Asbury | L. Kruskamp |
| Marjorie Bacheler | C. A. Landsidle |
| B. S. Biggs | C. V. Lundberg |
| G. Bittrich | E. P. Mack |
| Lois Burford | J. Madden |
| A. E. Clark | D. J. Mahoney |
| Kathleen Culbertson | Rose Mancuso |
| E. J. Davis | J. M. Meehan |
| L. Dorrance | C. C. Miller |
| E. E. Emerson | Phyllis Nimmo |
| C. W. Engelke | Jean Norris |
| R. H. Erickson | Lillian Ortolan |
| E. E. Francois | N. R. Pape |
| C. J. Frosch | J. H. Riley |
| L. O. Fry | C. Sconyers |
| Frances Galbavy | Dorothy Shaw |
| Gilbert Goodman | T. H. Thomas |
| I. J. Grunfest | F. C. Tolley |
| C. E. Hollister | P. Venneman |
| J. B. Howard | L. Vieth |
| Elizabeth Hyde | Marion Yannell |
| Q. Jaycox | M. F. Zimmer |

ment, for which it had been considered inadequate, and for which India mica has been required, will probably be permitted as a result of a new grading system being developed by WPB in cooperation with Bell Telephone Laboratories, Inc.—*New York Herald Tribune, September 15, 1943.*

According to an article (BELL LAB REC., 21, No. 8; April, 1943) by F. S. MALM, the Bell Laboratories have for many years been actively engaged in research on the chemical and physical properties of rubber and its compounds, to determine the kind of materials required to withstand severe weathering and the constantly changing conditions of temperature, humidity and light exposure.—*Nature, London, August 7, 1943.*

Equipment for securing data on the efficiencies of air filters is described in an article by O. C. ELIASON (BELL LAB REC., 21, No. 8; April, 1943).—*Nature, London, August 7, 1943.*

copper, nickel and platinum, and of iron and stainless steel, have been determined recently by the Bell Laboratories. . . . —*Nature, London, July 24, 1943.*

Under wartime urgency to meet measurements more exacting than ever before, U. S. industry has been moving quality control away from rule of thumb toward rules rigid as physical law. The pioneer in this field is DR. WALTER A. SHEWHART.—*Fortune, October, 1943.*

In High-Gain Amplifiers the noise contributed by the first tube is of prime importance since it determines the ultimate signal-to-noise ratio. A method of tube-noise measurement is described in the August, 1943, issue of the BELL LABORATORIES RECORD in an article by J. J. DEBUSKE titled "Noise Measurements in Vacuum Tubes."—*Radio, September, 1943.*

One thing the world needs is an amplifier for the still small voice.—*The Villager, September 16, 1943.*

Wider use of domestic mica in a variety of applications within radio-frequency equipment
November 1943

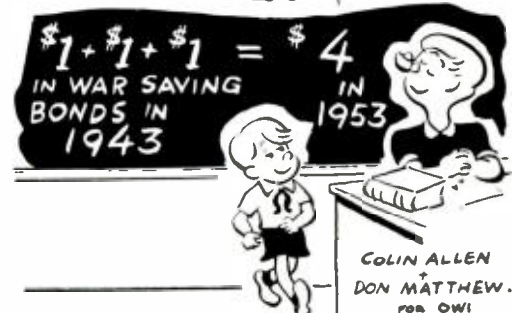
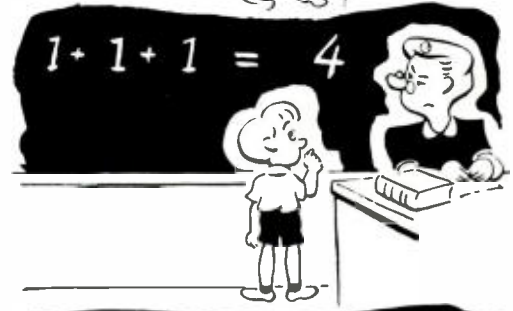
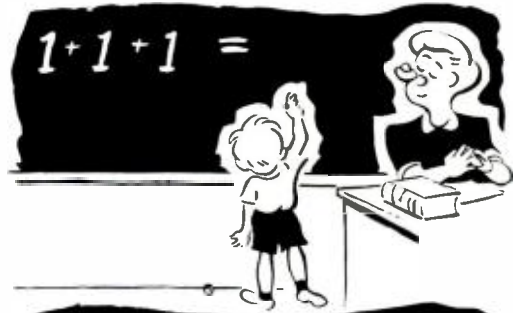

COLIN ALLEN
DON MATTHEW.
FOR OWI

Bell, A. G. and Decibels—*an editorial by John Miller*

MONUMENTS more enduring than bronze have been erected to the discoverers of the fundamental phenomena of electricity by the application of their names to the units of that science. Faraday, a pure genius; Gilbert, the physician with his terrella and compass needles; Volta with his battery; Coulomb; Ampere; Gauss; Ohm; Watt, whose first name was James, not Kilo; Maxwell, the mathematically minded; Joseph Henry of Princeton; Joule; Oersted; a mighty army.

Alexander Graham Bell is commemorated by the "bel" and its euphonious submultiple, the "decibel." This unit is used for the comparison of the power of sound — or of electric power while being telephonically transmitted. Unlike kilowatt or horsepower, it stands not for an amount but for a percentage difference in power.

Underlying its adoption, although not decisive therein, was a psychological justification. A general law — subject to exceptions — relates increase of sensation to increase of stimulus. If, for example, you listen alternately to two pure musical tones of identical pitch and equal intensity you will hear them equally loud. Now keeping one fixed in intensity, increase the other by small steps and compare after each change. You will find the sound must be increased in power about 26 per cent before a difference in aural sensation is perceptible.

The next sensation level, in other words, corresponds to a stimulus about 1.26 times

greater. If 10 represents the original power, successive levels just perceptibly different in sensation are 12.6, 15.8, 20.0, 25.1, and so on—do your own arithmetic or consult the scale pictured below.

The stimuli corresponding to this series increase successively by one decibel. Qualitatively, in other words, we can think of one decibel as measuring the minimum increase in stimulus to give a new kick. If ten cigarettes a day no longer satisfy, your next number should be 12.5, and when that fails, 16.

By definition, one decibel measures comparatively two powers where one is 25.9 per cent the larger. If the difference is 2 db, one is 58.5 per cent larger; if 3 db, the percentage difference is 99.5 — that is, one is practically double the other. If you tell someone to pipe down by 3 db, you mean reduce to one-half the vocal power.

The great convenience of the decibel—inherent in its logarithmic character and telephonic origin—is its additive property. Ten db, for example, means a tenfold increase in power. Hence 20 db means ten times tenfold or a hundredfold. Also, for example, since 3 db means twofold power, 13 db—which is 10 plus 3—means ten times twofold or twentyfold power. Simple addition serves for computation.

The decibel, the unit named after Bell, like the telephone system developed from his invention, is convenient and simple to use—the complexity is all behind the scenes.

