



Innovation  
that excites

# NISSAN PATROL



NSC STAMP

NISSAN  
PATROL



THE LIVING LEGACY. GO ANYWHERE, ANYTIME.

FIRST GENERATION 4W60

## 1951-1960



The NISSAN PATROL legacy began in 1951 with the 4W60.

It had an authentic 4X4 chassis, selectable 4WD and a powerful 6-cylinder engine. The 4W60 quickly proved to be the most reliable, rugged and downright versatile 4X4 available, and it was not long before it became the preferred mode of off-road transportation in many parts of Asia.

The first generation PATROL went through many changes as NISSAN made constant improvements to the engine and look of the vehicle.

The 4W65, which was introduced in October 1958, was the first to boast a NISSAN badge on the grille and PATROL badge.

The 4W73, which was launched in 1959, marked the end of the impressive first generation.

SECOND GENERATION G60

## 1960-1980



Building on the impressive achievements of the first generation was the soft-top PATROL 60 series or G60.

This three-door, four-seat model was first sold in Australia in 1960 and was with short-, medium- and long-wheelbase chassis. It has a 3956cc petrol engine, four-speed manual gearbox and leaf-springs all-around.

The second generation PATROL captured the imagination of the Australian market when it became the first vehicle to cross the treacherous Simpson Desert. This daunting desert covers an area of 176,500sq km and contains the longest parallel sand dunes in the world, some of which are over 40m high.

THIRD GENERATION 160 SERIES

## 1980-1987



Next in line was the PATROL 160 series, which was launched in 1980.

With a five-door layout and seating for seven people, the 160 was the ultimate family adventure vehicle of the 80's. Air conditioning and power steering were big and welcomed improvements and some versions also featured Limited Slip Differentials (LSD), which further improved off-road handling.

The 160 series quickly came to be loved and respected for its uncompromising quality and strength, and these are still a common sight in challenging terrains everywhere.

The third generation PATROL'S reputation was further strengthened by winning first place in the Paris-Dakar Rally in 1984 and second place in 1985 in the Production Diesel class.

FOURTH GENERATION Y60

## 1987-1997



The Y60 PATROL, was introduced to the world in 1987, and was radically different from its predecessors.

It had coil-spring suspension and the rear axle was on a 5 link setup which considerably improved the NISSAN PATROL'S on-road handling, whilst still retaining its unmatched and legendary off-road performance. This model also had a five-speed transmission and all-round disc brakes. Some Y60s even featured a PTO-driven front mounted winch.

As a result of its superb wheel articulation (making it the perfect vehicle for rock-crawling) combined with the ease with which parts can be replaced out in the field, it is still being manufactured for military purposes in Asia and the Middle East.

FIFTH GENERATION Y61

## 1997-2004



When the Y61 hit the market in 1997 it was clear that NISSAN not only stayed true to the traditions of the original PATROL but surpassed it.

Its underbody hardware was so significantly strengthened that it is still considered to be the strongest components fitted to any production 4WD.

Technological developments included an automatic gearbox, electric windows and mirrors plus the fitment of a chilled cooler box between the front seats. NISSAN also added a host of safety features including all-round ABS for the fully ventilated disc brakes, powerful Halogen headlamps and a reinforced cabin structure with side impact beams.

This remarkable 4x4 came third in the 2003 FIA cross-country Rally World cup in the T1 class and won the 2004 Dakar Rally in the T1 class.

SIXTH GENERATION Y61FACELIFT

## 2004-2010



In 2004 the significantly face-lifted PATROL Y61 was released.

It boasted new headlights, box flares on each guard, larger tail lights and an extra 40ℓ fuel tank and could seat up to ten people. NISSAN also made a two-door pickup version of the Y61 series available as a bare chassis and cab. The Y61 series is still a favourite amongst off-road enthusiasts.

Thanks to the PATROL Y61's dependability and superior 4X4 capabilities, it was selected for the Miles Ahead Expedition into Africa undertaken by Barclays Bank in 2005.

This voyage saw the PATROL team covering 17 countries in total, and some of the world's most inhospitable terrain in only 157 days.



SEVENTH GENERATION Y62

# THE PINNACLE OF METICULOUSLY CRAFTED LUXURY

A reputation for superior performance that spans more than six decades has earned the NISSAN PATROL enviable recognition as the 'King of the Off-Road'. It is no surprise that the PATROL is a formidable presence in the African off-road vehicle landscape.

# THE GREATEST ADVANCE IN 4X4 HISTORY

The impressive exterior of the NISSAN PATROL shields an interior that offers nothing short of first class comfort and style. The designers of the PATROL have paid significant attention to every detail. Large panelled wooden areas, chrome finishes and soft touch leather gives this vehicle a status of sophistication.

By combining functionality, versatility and powerful performance with an attractive design, superior styling and refinement, the PATROL takes sophistication and capability to a whole new level. Placed as the most powerful and technologically advanced 4x4 in its class, the PATROL offers the discerning motorist modern lines, innovative safety features, highly advanced technologies, supreme comfort and more.



# CONTENTS

THE LIVING LEGACY. GO ANYWHERE, ANYTIME.	ii
THE PINNACLE OF METICULOUSLY CRAFTED LUXURY	vi
THE GREATEST ADVANCE IN 4X4 HISTORY	vii
INTELLIGENCE TO ADAPT TO ANY TERRAIN	03
SUPERIOR PERFORMANCE, STABILITY AND CONTROL	05
RAW POWER THAT PUTS YOU AHEAD OF THE PACK	08
CRAFTED WITH YOU IN MIND	09
INNOVATION EXPRESSED IN ELEGANCE	12
THE PERFECT BALANCE BETWEEN LUXURY AND TECHNOLOGY	14
FIRST-CLASS LEVELS OF COMFORT	18
THE VEHICLE THAT PROTECTS YOU	21
EXCLUSIVE BODY COLOURS AND TRIM	23
DIMENSIONS	25
SPECIFICATIONS	26





POWER AT YOUR COMMAND



OFF-ROAD CAPABILITY

# INTELLIGENCE TO ADAPT TO ANY TERRAIN

Armed with an array of ingenious technologies, the NISSAN PATROL makes every trip a pleasure.

**Auto Speed Cruise Device (ASCD)** helps make driving less tiring on long trips. A simple touch of a button activates the cruise control and allows you to set the desired cruising speed.

The NISSAN **Intelligent Key** allows for just the press of a button on the door handle or trunk to unlock them, while the keys remain in the pocket or purse. With the standard Push Start Button feature the vehicle is ready to go with just a push of the button. This technology also memorises the driver's seat position and for added safety the engine immobiliser prevents anyone without the key from starting the car.

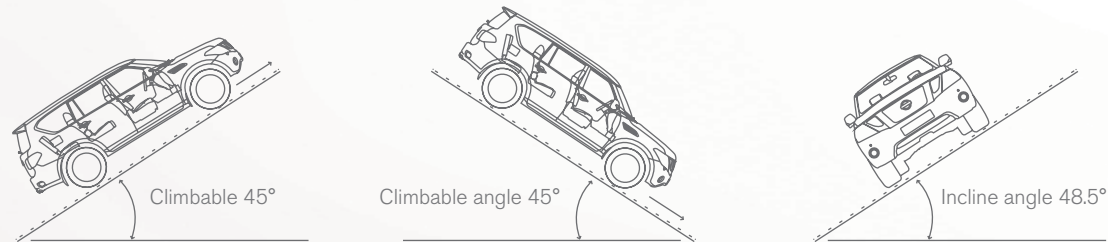

The **ALL MODE 4x4** system utilises advanced electronics to ensure that no matter how severe the driving conditions, the PATROL will be able to grip the road at all times by transferring drive between wheels and axles.

**Variable 4x4 Mode** select allows you to effortlessly switch between four drive modes; sand, on-road, snow and rock with just a flick of a switch.





INNOVATIVE TECHNOLOGY

# SUPERIOR PERFORMANCE, STABILITY AND CONTROL

Travelling in Africa presents a diverse range of challenging landscapes and the NISSAN PATROL is well equipped to tackle any terrain thanks to its technology, design and forethought.

**Hydraulic Body Motion Control (HBMC)** system offers 4-wheel independent suspension. Working with the chassis and body frame the system maximises the suspension stroke on off-road running and prevents roll angle, to maintain flat riding with high damping force at cornering. The HBMC system gives the PATROL superb stability on rugged and sandy terrain, while also delivering a comfortable ride in the city.

**Helical Limited Slip Differential (LSD)** and **Rear Differential Lock** allows the driver to maintain momentum, even on slippery slopes or roads when a wheel is spinning or slipping.

**Active Brake Limited Slip (ABLS)** is a traction control mechanism that uses sensors from the **Anti-lock Braking System (ABS)** to transfer power from a slipping wheel to a wheel with more traction.

**Off-Road Monitor** function offers information to support off road driving tyre conditions, while the **Tyre Pressure Monitoring System (TPMS)** with tyre inflation indicator provides visual and audible signals outside the vehicle for inflating the tyres to the recommended pressure.

**Hill Start Assist (HSA)** is useful when the driver encounters a steep incline. HSA applies brake pressure for two seconds after the driver releases the brake pedal to avoid any roll back before moving forward. With this technology, the driver feels secure on a slope particularly in sandy or gravel conditions.

**Hill Descent Control (HDC)** assists the driver down a steep or slippery slope at a constant slow speed without the need for braking, enabling the driver to concentrate on handling the vehicle.

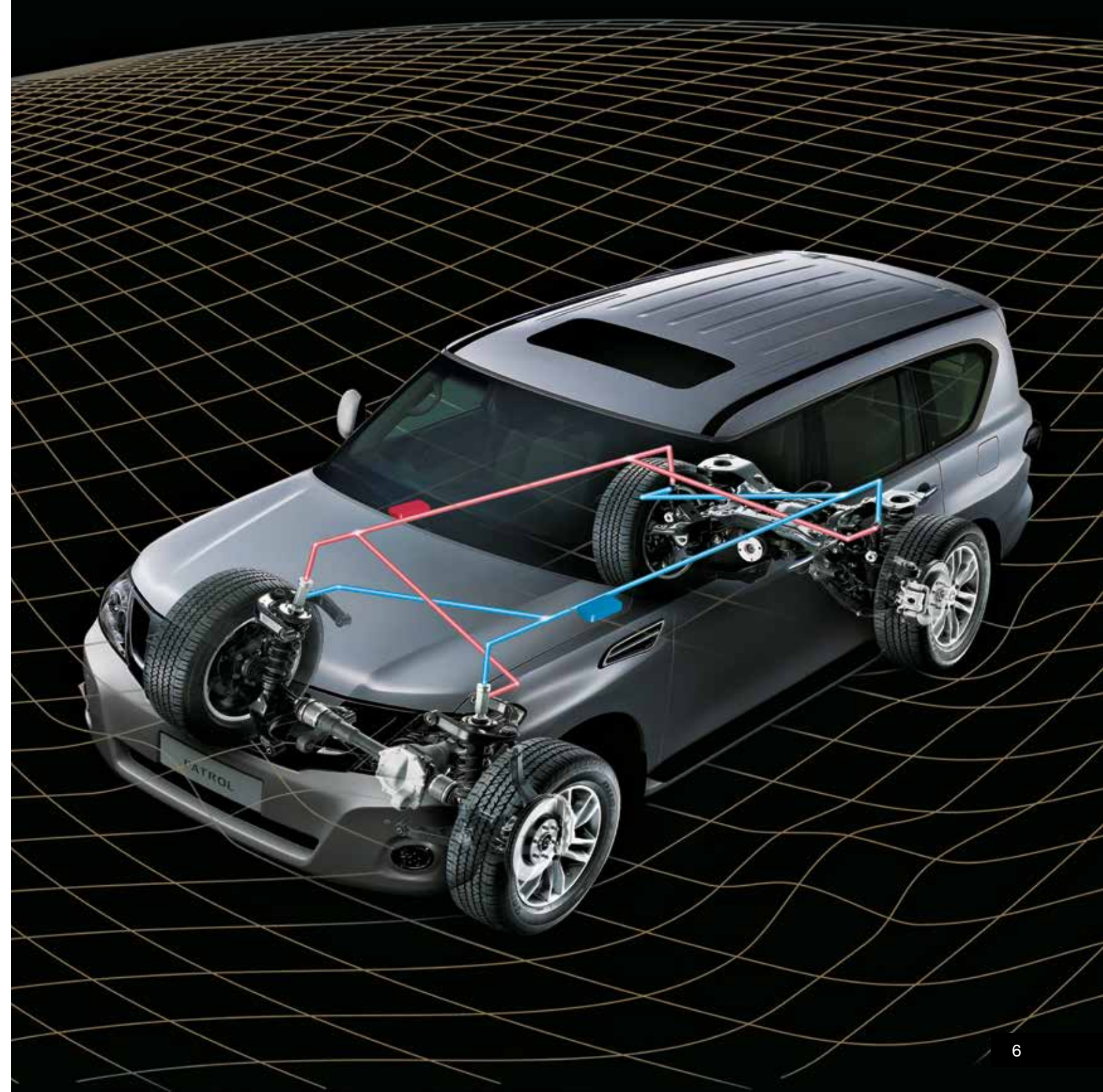



CLASS-LEADING ENGINE PERFORMANCE

# RAW POWER THAT PUTS YOU AHEAD OF THE PACK

From the very beginning, the NISSAN PATROL has been synonymous with power. Each new model has employed advanced technologies that enhance both on and off-road performance to unsurpassable levels. The latest generation PATROL is no exception.

The 5.6L V8 engine offers the ultimate power trip. Variable Valve Event and Lift (VVEL) and Direct Injection Gasoline (DIG) technologies improve efficiency, power and torque with lower emissions. The 7-speed VVEL automatic transmission with manual mode, offers seamless acceleration with 298kW of power and 560Nm of torque that delivers a drive of unmatched performance and dynamic control.

POWER

**298kW**  
400hp

TORQUE

**560Nm**

AUTO TRANSMISSION

**7-SPD**



## NISSAN'S COMMITMENT TO THE ENVIRONMENT

Nissan's environmental philosophy embraces people, vehicles and nature. In the pursuit of a sustainable mobile society, the Nissan Green Program aims to reduce the environmental impact of Nissan vehicles at every stage of the vehicle life cycle, while corporate activities address environmental challenges.

SOPHISTICATED INTERIOR REFINEMENT

# CRAFTED WITH YOU IN MIND

A fresh and modern design approach underpinned the creation of the formidable exterior. From the high-tech image of the front head lamps to the dynamic rear end sporting combination lamps, each exterior element on the NISSAN PATROL is a statement in luxury. The bold window graphic of the blackened A pillar, alloy wheels, as well as the new angle strut grille all contribute to the vehicle's formidable on-road presence. Chrome finishes on the air intake vents and window frames express dignity and grace. The integrated protective bumper has been designed with perfect approach angle to allow this off-road stalwart to go anywhere.

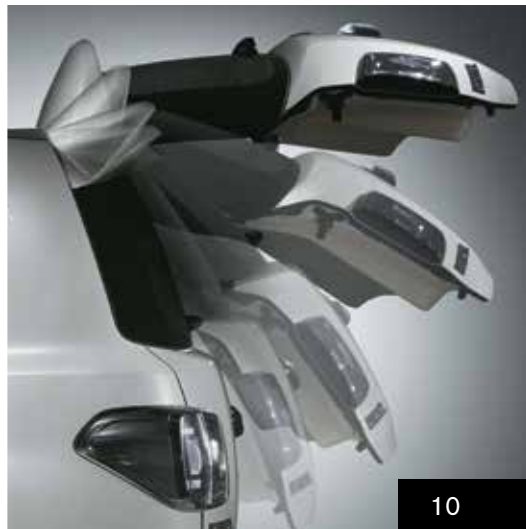



#### INTERIOR COMFORT

# INNOVATION EXPRESSED IN ELEGANCE

#### INTERIOR SPACE

The NISSAN PATROL offers the largest interior space in its class. Legroom has increased due to the longer wheelbase, and expansive luggage space is created in seconds through the easy seat folding operation. A built-in cooler box, that incorporates a double hinged design to enable access from both the first and second row seats, has capacity for six 500ml drinking bottles.

#### QUIET CABIN

In comparison to normal glass, the laminated windshield and front windows reduce noise by 35% in the PATROL. Ultra micro-fibre insulation, called thinsulate, in the front door panel and luggage areas, provides advanced insulation to maintain the cabin temperature and a quieter cabin.

#### TEMPERATURE CONTROL

The PATROL's air conditioning system features curtain vents mounted in the ceiling above each side window and upper vents mounted above the windshield. A strong current of cool air forms a curtain of air that acts as a barrier to heat penetrating the vehicle. Dual Zone climate control allows front and rear passengers to personally set the air conditioning to different levels.

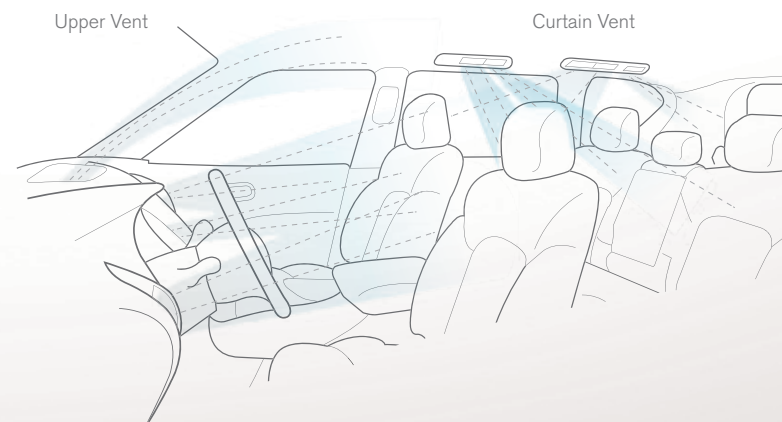



INTERIOR TECHNOLOGY

# THE PERFECT BALANCE BETWEEN LUXURY AND TECHNOLOGY

The NISSAN PATROL technologies are practical, useful and indulgent. Enjoy home LCD quality on the two 7-inch WVGA monitors for second row passengers with two headphones and a remote control. The 8-inch WVGA navigation display monitor on the sizable instrument panel in the front of the vehicle offers superb clarity. The three monitors display three different screens, connecting to the various sources of music, video and entertainment, such as the DVD, iPod and game player.



**SECOND ROW SCREENS.** A 7" multi-screen entertainment system with headsets and a remote control will keep all second row passengers firmly glued to their seats.



**8-INCH SCREEN.** See it all with the 8" Wide Video Graphic Array (WVGA) centre display.



**DVD PLAYER.** A multi-format DVD player will ensure you're entertained whenever and wherever you go.



**BLUETOOTH®.** Stay connected with Bluetooth® capabilities in the PATROL. Radio AM/FM, CD/MP3 player with 2GB HDD music box (500MB storage), Bluetooth, USB and iPod connectivity.



**INSTRUMENT PANEL.** The fine vision instrument display provides all of the driver's information needs in a stylish way.



**NISSAN INTELLIGENT KEY.** Allows the driver to keep the key in his or her pocket when unlocking and starting the vehicle.

**MULTI-SCREEN DVD ENTERTAINMENT SYSTEM**

The passengers in the 2nd row can enjoy the two displays on the back of the 1st row headrests, with two headphones and a remote-control switch.

**CLIMATE CONTROLLED SEATS**

Driver seat slide and recline adjustment with lifter, lumbar, memory and climate control.

**COOLER BOX- CENTRE CONSOLE**

The console box with cooling function allows easy access for both 1st & 2nd row passengers.

**HOSPITALITY LIGHT**

The puddle light, lightens the step for your safety.

**4WD SYSTEM - CONTROLLER**

Control switches of 4WD related devices are integrated for smart access.

**BOSE SOUND SYSTEM**

Passengers can enjoy high quality sound with 13 BOSE speakers. All passengers listen to the same quality sound in any seat.

**LUGGAGE SPACE**

By folding flat the 2nd and 3rd row seats, a large luggage space of 3170 litres is created.

**TAILGATE**

The tailgate has adopted auto open/close buttons with power both on the driver's seat and on the bottom of the gate.

**QUIET AND COMFORTABLE CABIN SPACE**

Laminated windows, ultra-micro fibre insulation and aerodynamics contribute to the quiet cabin.

**ROOMY CABIN**

Class-leading knee, shoulder and headroom.

**AUDIO STEERING CONTROL DEVICE**

Leather-wrapped steering wheel and controls with power tilt adjust and telescopic.

**LUXURY CONSOLE**

Well-harmonised chrome and wooden panel.

**AIR CONDITIONER**

The Dual Zone climate control with upper vents and rear curtain vents, cool down the inside effectively.

**ENGINE - VK56DE**

Powerful 5.6/ V8 with outstanding power (298kW).



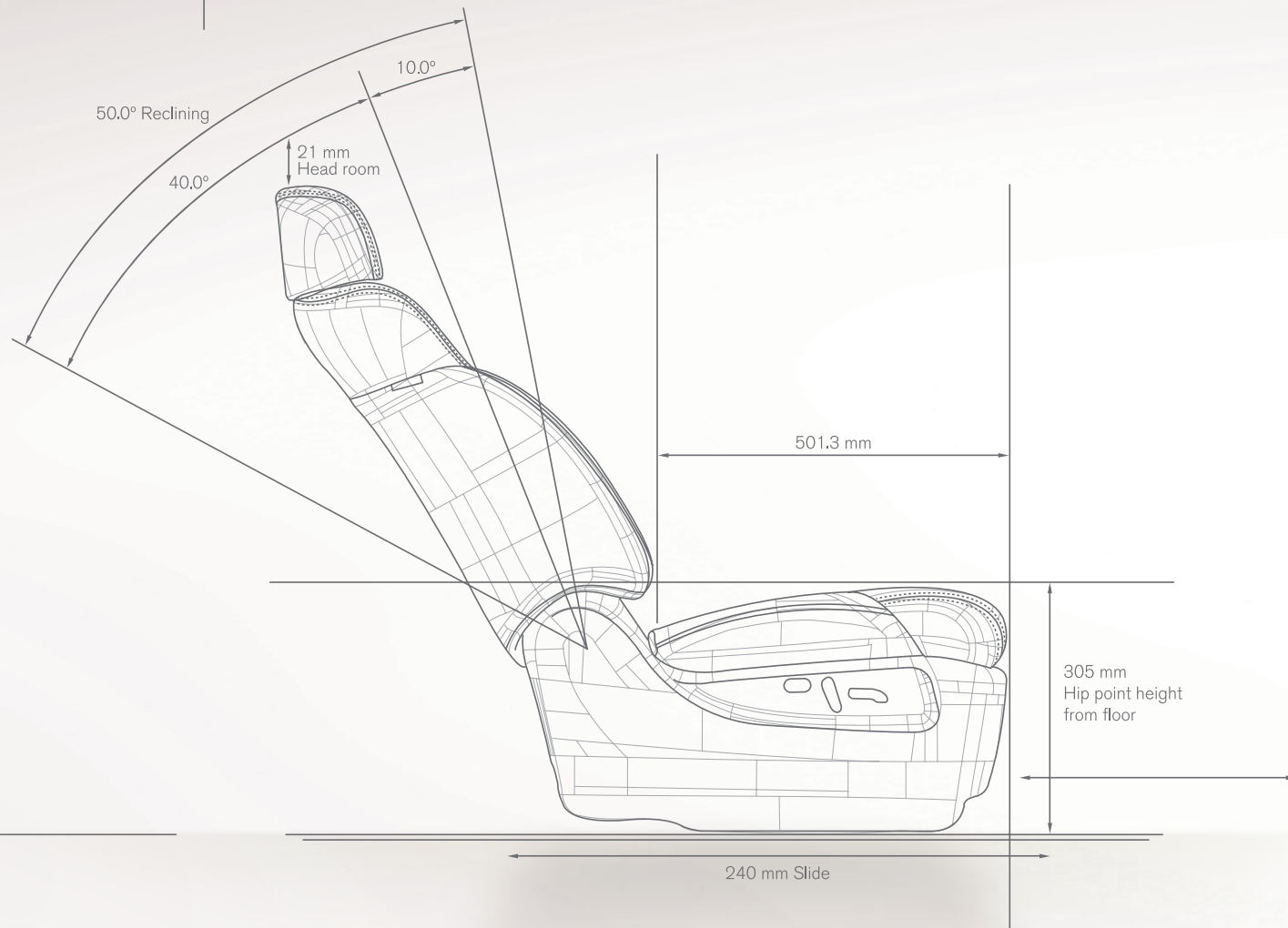

INTERIOR COMFORT

# FIRST-CLASS LEVELS OF COMFORT

Every journey in the NISSAN PATROL is more enjoyable than the previous one.

In keeping with the PATROL'S mission to deliver more comfort and more room, the PATROL offers versatile luxury leather seat dimensions that outclass the competition. Voluminous cushions for enhanced comfort on 3 rows of more-luxurious-than-ever seating, while the lavish space around the 2nd row seats is reminiscent of a private jet, the 3rd row seats offer unprecedented comfort thanks to the new reclining and sliding mechanism.

The possible 8 different seating/cargo configurations in the 1st, 2nd and 3rd row create the biggest rear luggage space in its class with the ultimate comfort.



ENHANCED INTERIOR  
COMFORT AND LUXURY  
FOR THE WHOLE FAMILY



# THE VEHICLE THAT PROTECTS YOU

THE "SAFETY SHIELD" CONCEPT WILL HELP THE DRIVER TO:



### MAINTAIN COMFORTABLE DRIVING CONDITION

In the event of potential risk, NISSAN technologies make it easier for the driver to maintain safe driving conditions. Some of these innovations reduce the driver's burden, while others enhance visibility and awareness of the immediate surroundings, at night and when parking.



### RECOVER FROM DANGEROUS CONDITIONS TO SAFE DRIVING

When a risk appears, warnings and automatic countermeasures help the driver recover from dangerous driving conditions to avoid the risk and resume safe driving.



### MINIMIZE DAMAGE WHEN A COLLISION IS UNAVOIDABLE

In cases where a collision cannot be avoided, the inherent NISSAN technology deploys to minimise damage, and more importantly help reduce injuries by activating the brakes, restraining passengers, and applying other measures.



### Vehicle Dynamic Control

Automatically prevents the vehicle from sliding sideways on slippery road surfaces when changing lanes or negotiating a curve.



### ABS and EBD

The Anti-lock Braking System (ABS) helps prevent skidding during emergency braking, while Electronic Brake force Distribution (EBD) optimises brake force according to payload.



### Intelligent Brake Assist

Enhances full braking performance in emergency situations, with its high quality anti-fading performance brake, the PATROL incorporates intelligent Brake Assist (BA) technology.



### Zone body construction

Enhances cabin safety by combining impact-absorbing "crushable zones" with a high-strength "occupant zone" to protect passengers.



### Front Seat Belt Pretensioners and Load Limiters

Seat belt pre-tensioners on front seat belts automatically tighten the seat belts in certain frontal collisions, while load limiters are designed to give a little, to absorb belt-force load transmitted to front occupants.



### Active Head Restraints

In certain rear-end collisions, front seat active head restraints move upward and forward to help cushion the head, and to reduce whiplash-type injuries.



### 6-SRS Airbag System

The 6-SRS Airbag System in the NISSAN PATROL comes equipped with driver and front passenger airbags, front-seat mounted side airbags and roof-mounted curtain airbags to cushion its occupants in the event of a collision.



### Crash-sensitive Door Unlock

On detecting a collision, the crash-sensitive door unlock function will automatically unlock to ensure free movement of the occupants.



### High Intensity Discharge (HID) xenon headlamps

Ensures bright and consistent illumination of the road which increases comfort and reduces fatigue when driving when dark.



### Elevated Cockpit

The elevated cockpit area is made possible by the ground clearance of 283mm to ensure optimal visibility at any weather and road conditions.



### Around View Monitor

The Around View Monitor uses four cameras to display a bird's eye view of the vehicle to assist with parking even in tight spots.



### Intelligent Cruise Control

Intelligent Cruise Control maintains the desired distance between the vehicle and slow moving traffic, and accelerates to the pre-set speed and distance as the traffic flow picks up.



Around View Monitor



Vehicle Dynamic Control

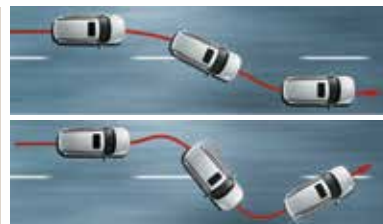

Intelligent Brake Assist

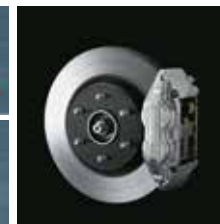

6-SRS Airbag System

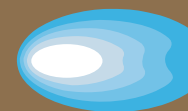

SAFETY SHIELD

In the commitment to "Real World Safety", NISSAN pursues innovation as part of its Safety Shield concept. Based on the idea that cars should help protect people; advanced and proactive safety technologies help driver and passengers to avoid danger and injury.

# EXCLUSIVE BODY COLOURS AND TRIM



Light Beige [PM]/HAE



Grey [M]/K51



Black [2S]/KH3



Silver [M]/K23



Pearl White [3P]/QAA



Brownish Purple [2P]/L50



Greyish Green [PM]/JAE



Interior black leather seat trim.

## NISSAN'S COMMITMENT TO QUALITY

To provide each of our customers with a consistently high level of quality, we apply the same high quality standards worldwide - ensuring that all Nissan owners enjoy peace of mind for the lives of their vehicles.

## DIMENSIONS

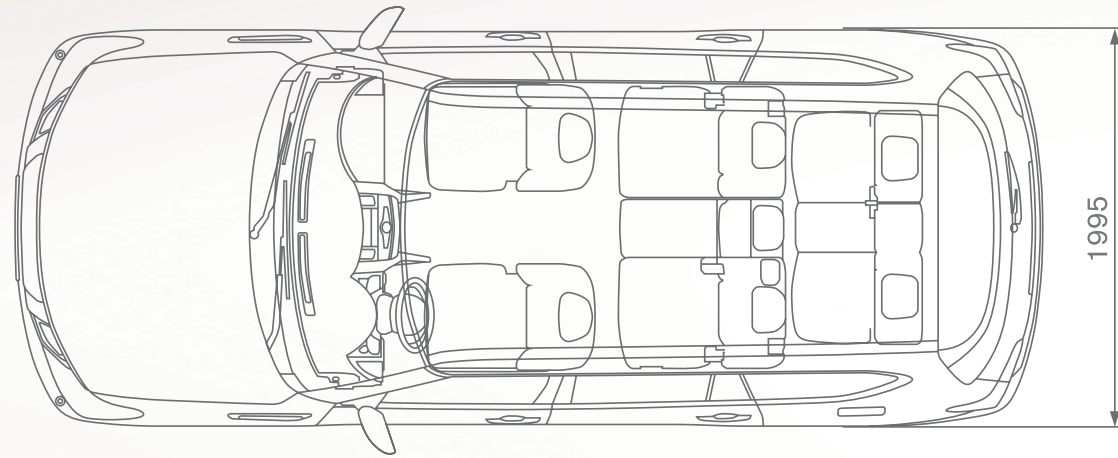

Unit: mm

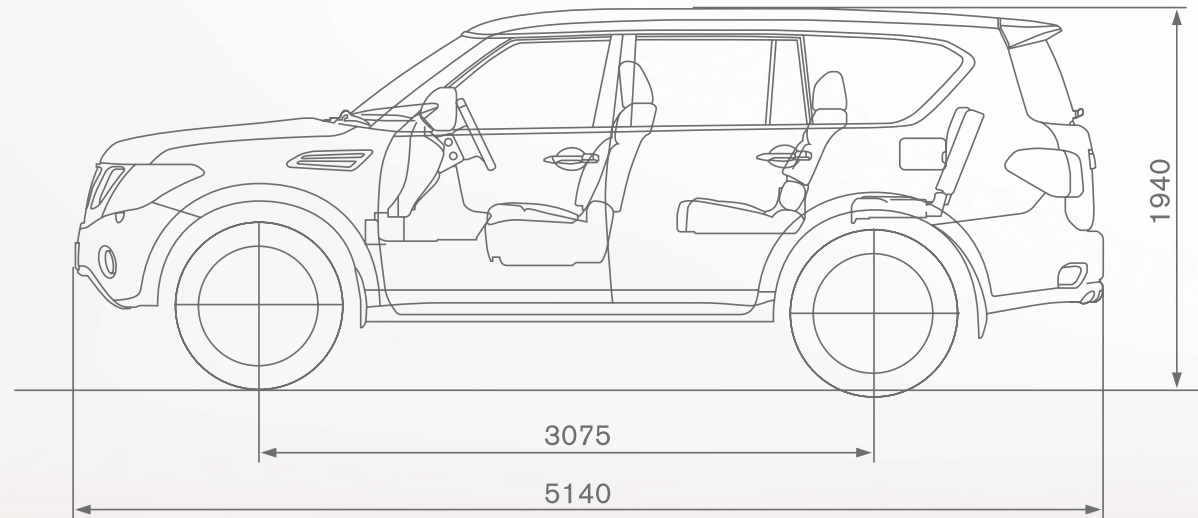

## SPECIFICATIONS

MODEL		LE	LE+
<b>ENGINE INFORMATION</b>			
Max power	kW (hp)	298 (400)@5800rpm	
Max torque	Nm (kg-m)	560 (53.7)@4000rpm	
Number of cylinders, configuration		8, in line	
Valves per cylinder		4, DOHC	
Air intake system		Natural Aspiration	
Engine capacity	cc	5600	
Bore x Stroke	mm	98 x 92	
Compression ratio		10.8	
Fuel type		Petrol	
Fuel capacity	litres	140	
Engine type		DOHC V8 - Direct fuel injection	
Max speed	km/h	200	
<b>TRANSMISSION</b>			
7-speed VVEL A/T with manual mode & synchro rev. control			Standard
Gear ratio		4.887	
		0.775	
Reverse gear ratio		4.041	
Transfer gear ratio		2.679	
Final gear ratio		3.357	
<b>MECHANISM</b>			
Front and rear suspension with HBMC		N/A	Standard
Front and rear suspension		Standard	Standard
Front and rear ventilated disc breaks		Standard	Standard
<b>DIMENSIONS AND WEIGHTS</b>			
Overall length, height, width		mm	5140, 1940, 1995
Wheel base		mm	3075
Interior height 1st/2nd/3rd row		mm	1267/1253/1110
Luggage capacity (VDA) behind 1st row		litres	3170
Luggage capacity (VDA) behind 2nd row		litres	1490
Luggage capacity (VDA) behind 3rd row		litres	550
Kerb weight		kg	2830
Gross Vehicle Mass		kg	3450
Maximum trailer weight braked (towing capacity)		kg	3500
Maximum trailer weight unbraked (towing capacity)		kg	750
Permissible vertical force on hitch ball		kg	140
Maximum roof load with roof rails		kg	100

MODEL		LE	LE+
<b>CAPABILITIES</b>			
All MODE 4x4			Standard
Front overhang	mm		925
Rear overhang	mm		1 140
Turning circle	m		12.5
Ground clearance	mm		283
Departure angle	Deg		26
Approach angle	Deg		35
Ramp breakover angle	Deg		24
Maximum wading depth	mm		700
Limited Slip Differential (LSD)			Standard
Rear diff lock			Standard
<b>COMFORT AND CONVENIENCE</b>			
Intelligent key entry and engine start/stop			Standard
Power steering		Standard	Twin Orifice
Steering wheel height , tilt adjust and telescopic			Standard
Drive computer			Standard
Air conditioning: Front auto dual zone climate control. Rear indirect full auto dual zone climate control			Standard
Cruise control with Audio Steering Control Device			Standard
Radio: AM/FM & FM SUB, FM diversity, 1 DVD, MP3 and 13 premium BOSE speakers			Standard
USB, iPod and handsfree Bluetooth connectivity			Standard
Navigation monitor LCD 8" colour QVGA display		Standard	N/A
Navigation monitor front: LCD 8" QVGA C/DISPLAY / rear: LCD 7" colour display with Infrared, Bluetooth & VTR JACK & Rear entertainment system)		N/A	Optional
Auto light system and automatic hazzard warning signal			Standard
Auto compass intergerated in mirror			Standard
Interior rear view mirror with electric anti-dazzle			Standard
Exterior rear view mirror with light, defrosting and heater		N/A	Standard
Heated rear screen with defogger, timer and intermittent wipers			Standard
Electric adjustable rear view mirror			Standard
Electrical outside folding mirror with manual anti-dazzle			Standard
Automatic adjustable xenon headlamps with headlight wipers			Standard
Tinted windscreen variable intermittent wipers with mist and speed sensor			Standard
Programmable exterior rearview mirrors with position memory synchronisation			Standard
Sunroof roof front tilt & rear slide		N/A	Standard
Front and rear electric, timer, anti-pinch window			Standard
Driver and passenger sunvisor with mirror, lights and extension			Standard
No. of cup holders: 7 and 8 bottle holders			Standard
Roof console storage, microphone and sunglass holder			Standard
Front and rear door storage			Standard
Rear seats personal lighting			Standard
Glove cool box with light, lock and damper		N/A	Optional
Centre console with storage and cool box			Standard
Luggage room with 8 hooks, light and secret storage			Standard
12Vx4 sockets: Front and rear side of front console and luggage side			Standard
Rear tailgate auto close			Standard
Rear tailgate with auto closer and power back door		N/A	Standard

MODEL		LE	LE+
<b>INTERIOR</b>			
Front headrest		Active headrest	Active headrest with 7" WVGA Display
Driver seat slide and recline adjustment with lifter, lumbar memory and climate control		Manual adjust	Electric adjust
Passenger seat slide, recline and lift adjustment		Manual adjust	Electric adjust
Rear headrest			Standard
2nd row seats with manual reclining, rear centre armrest with storage and manual fold			Standard
3rd row seats 60:40 split manual lever fold down and reclining			Standard
Seat material			Black leather
<b>EXTERIOR AND TYRES</b>			
Front and rear fog lights			Standard
Turn signal light with side repeaters on door mirrors			Standard
Roof rails		N/A	Standard
Tyre size			265/70R18 Alloy
Spare wheel full size			Standard
Towing hook: 3			Standard
<b>SAFETY AND SECURITY</b>			
Driver, passenger, side and curtain airbags			Standard
ABS, EBD, BA			Standard
Driver and passenger 3 point ELR seatbelt with reminders, pre-tensioners and load limiters			Standard
Rear seatbelts 2nd and 3rd row 3-point ELR with height adjust			Standard
ISOFIX with 2 tether			Standard
Path control with Vehicle Dynamic Control (VDC)			Standard
Hill Start Assist (HSA), Hill Descent Control (HDC)			Standard
Driving assistance with around view monitor and proximity radar			Standard
Parking and corner sensor			Standard
Rear LED lamp			Standard
Raised brake lights			Standard
Electric door locking with crash sensitive door unlock function			Standard
Anti-theft device immobiliser and alarm			Standard

Disclaimer: Every effort has been made to ensure that the contents of this brochure is correct at the time of going to print (July 2013). This brochure has been produced featuring prototype or accessorised vehicles exhibited at motorshows and in accordance with the company's policy of continuously improving its products. Nissan South Africa reserves the right to change the specifications and the vehicles described and shown in this brochure at any time. Nissan dealers will be informed of any such modifications as quickly as possible. Please check with your local Nissan dealer to receive the most up-to-date information. Due to the limitations of the printing process used, the colours shown in this brochure may differ slightly from the actual colours of the paint and interior trim material used. All rights reserved. Reproduction in whole or part of this brochure without the written permission from Nissan is forbidden.