

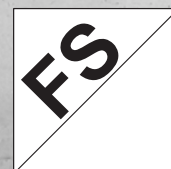

SEW
EURODRIVE

Manual

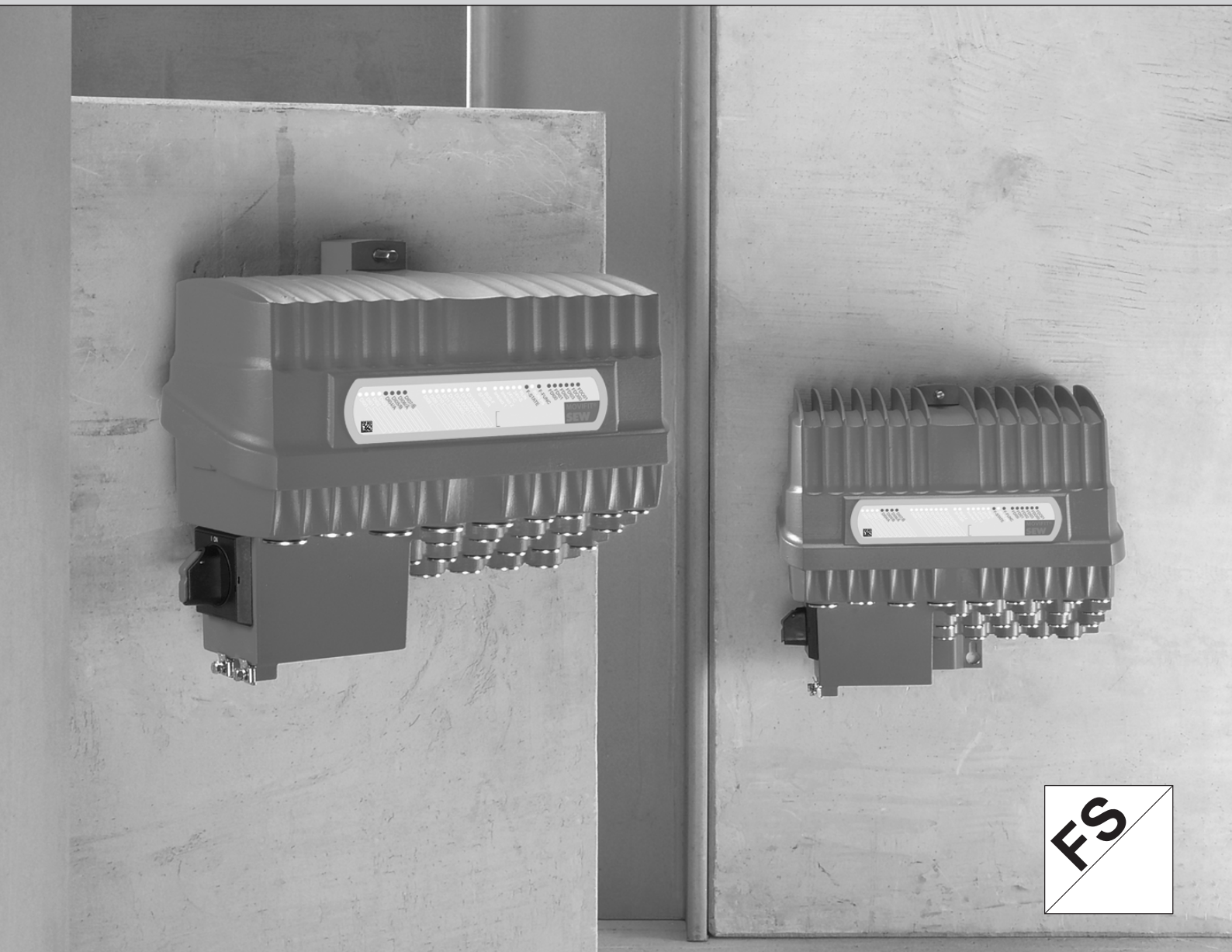

MOVIFIT® MC/FC Functional Safety with S12 Safety Option



Contents

1	General information.....	9
1.1	About this documentation	9
1.2	Structure of the safety notes	9
1.2.1	Meaning of signal words	9
1.2.2	Structure of section-related safety notes.....	9
1.2.3	Structure of embedded safety notes	10
1.3	Rights to claim under limited warranty	10
1.4	Content of the documentation.....	10
1.5	Exclusion of liability.....	11
1.6	Other applicable documentation	11
1.7	Product names and trademarks.....	11
1.8	Copyright notice	11
2	Safety notes	12
2.1	General information	12
2.2	Target group	12
2.3	Designated use	12
2.4	Transportation, storage.....	13
2.5	Installation.....	13
2.6	Definitions	14
3	Safety concept	15
3.1	MOVIFIT® MC safety concept	15
3.1.1	MOVIFIT® MC block diagram	15
3.1.2	Functional description	16
3.1.3	Restrictions	17
3.2	MOVIFIT® FC safety concept	18
3.2.1	MOVIFIT® FC block diagram.....	18
3.2.2	Functional description	19
3.2.3	Restrictions	19
3.3	Safety concept of S12 safety option	20
3.4	Safety functions	21
3.4.1	STO – Safe Torque Off	21
3.4.2	SS1(a) – Safe Stop 1	22
3.4.3	SS1(c) – Safe Stop 1	23
3.4.4	SLS – Safely Limited Speed	24
3.4.5	SDI – Safe Direction.....	24
3.5	Safety concept of Assist S12	25
3.5.1	Safety parameters.....	25
3.5.2	Test concept and test procedure.....	25
4	Safety conditions.....	26
4.1	Nameplates.....	26
4.1.1	Nameplate position	26
4.1.2	Nameplate of complete device.....	27
4.1.3	Description of FS logo.....	27

22865268/EN – 06/2016

4.2	Device replacement requirements	27
4.3	Installation requirements	28
4.4	External sensors and actuators – requirements	28
4.5	Startup requirements	29
5	Hazard caused by a coasting drive.....	30
6	Electrical installation.....	31
6.1	Installation instructions.....	31
6.2	Safe disconnection MOVIFIT®	32
6.2.1	MOVIFIT® MC.....	32
6.2.2	MOVIFIT® FC	36
6.2.3	Voltage supply of the S12 safety option	39
6.3	S12 safety option	40
6.3.1	Terminal assignment.....	40
6.3.2	Safety-related inputs (F-DI.).....	43
6.3.3	Safety-related outputs (F-DO. and F-DO_STO).....	51
6.4	Built-in encoder EI7C FS	57
6.4.1	Properties	57
6.4.2	Installation	57
7	Safety functions of the S12 safety option	67
7.1	STO – Safe Torque Off.....	67
7.1.1	Description of the function.....	67
7.1.2	Activation.....	68
7.1.3	Status	68
7.1.4	Parameter	68
7.2	SS1(c) – Safe Stop 1	69
7.2.1	Description of the function.....	69
7.2.2	Activation.....	69
7.2.3	Status	69
7.2.4	Parameter	69
7.3	SS1(a) – Safe Stop 1	70
7.3.1	Description of the function.....	70
7.3.2	Activation.....	70
7.3.3	Status	70
7.3.4	Parameter	71
7.4	SLS – Safely Limited Speed	72
7.4.1	Description of the function.....	72
7.4.2	Activation.....	73
7.4.3	Status	73
7.4.4	Error response	73
7.4.5	Parameter	74
7.4.6	Speed filter	75
7.5	SDI – Safe Direction	76
7.5.1	Description of the function.....	76
7.5.2	Activation.....	77
7.5.3	Status	77

7.5.4	Error response	77
7.5.5	Parameter	77
7.6	Safety-related inputs	77
7.6.1	Description of the function	77
7.6.2	Connection type	78
7.6.3	Status	79
7.6.4	Error response	79
7.6.5	Parameter	79
7.7	Safety-related outputs	80
7.7.1	Description of the function	80
7.7.2	Error response	80
7.7.3	Status	81
7.7.4	Parameter	81
7.8	Function assignment	82
7.8.1	Parameter	82
7.9	Test mode	83
7.9.1	Description of the function	83
7.9.2	Activation	83
7.9.3	Status	83
7.10	Coasting time measurement	84
7.10.1	Definition	84
7.10.2	Description of the function	84
7.10.3	Determining the reference value	85
7.10.4	Activation	85
7.10.5	Parameter	85
8	Startup	87
8.1	General startup instructions	87
8.2	Startup variants 1 – 3	87
8.2.1	Variant 1: Default parameter setting (without "Assist S12" parameterization tool)	87
8.2.2	Variant 2: Independent operation (no connection to PROFIsafe)	88
8.2.3	Variant 3: With PROFIsafe connection	88
8.3	Setting the safety function parameters	89
8.3.1	Requirements	89
8.3.2	Parameter setting procedure	89
8.4	Startup of the fieldbus and the higher-level F-PLC	91
8.4.1	Requirements	91
8.4.2	Setting the PROFIsafe address	91
8.4.3	Configuring the S12 safety option in STEP 7	93
8.5	Verification and validation	97
8.5.1	Overview	97
8.5.2	Verification and acceptance protocol	97
8.5.3	Validation	99
9	Assist S12	100
9.1	Structure of the user interface	100

9.1.1	Menu bar	101
9.1.2	Parameterization steps	102
9.1.3	Tool bar	102
9.1.4	Parameterization window	103
9.1.5	Plausibility error indication	103
9.1.6	Status bar	104
9.1.7	Change password	104
9.2	Data management	105
9.2.1	Project-relevant files.....	105
9.2.2	Data management with non-configured S12 safety option	106
9.2.3	Data management with configured S12 safety option	106
9.3	Functional description	107
9.3.1	Parameter setting procedure.....	107
9.3.2	Establishing a connection	108
9.3.3	Parameterization	109
9.3.4	Validation	111
9.4	Device data	112
9.5	Status displays.....	112
9.6	Display and status of the safety functions.....	113
9.6.1	Overview	113
9.6.2	Safety function status.....	113
9.6.3	F-DI inputs.....	114
9.6.4	F-DO outputs.....	116
9.6.5	Test mode	116
9.6.6	Application coasting when selecting STO	116
9.7	Process data	117
9.8	Encoder.....	117
9.9	Error memory.....	118
10	Data exchange with higher-level controller	119
10.1	Introduction	119
10.2	F periphery access of the S12 safety option in STEP 7.....	119
10.2.1	F periphery DB of S12 safety option	119
10.2.2	F user data of S12 safety option	121
10.2.3	Activation examples for the S12 safety option	126
11	Response times	130
12	Service.....	131
12.1	Diagnostics LEDs.....	131
12.1.1	"FDI.." LEDs	132
12.1.2	"FDO.." LEDs	132
12.1.3	"F-FUNC" LED	132
12.1.4	"F-STATE" LED.....	133
12.2	STO jumper plug.....	134
12.3	X71F plug connector for safety-related disconnection (option).....	135
12.4	Error states of the S12 safety option.....	136
12.4.1	Error in the safety section	136

12.4.2	PROFIsafe timeout.....	136
12.4.3	Safety diagnostics via PROFIBUS DP	137
12.4.4	Safety diagnostics via PROFINET IO	137
12.5	Diagnostics with Assist S12	138
12.5.1	Status displays	138
12.5.2	Error memory	140
12.6	Device replacement	142
12.6.1	Data backup	142
12.6.2	Device replacement depending on the operating mode.....	142
12.6.3	EBOX device replacement	143
12.6.4	Device replacement of ABOX with/without EBOX.....	145
12.7	Error table of the S12 safety option	146
13	Parameter description.....	155
13.1	General information	155
13.1.1	10122.7 IO error effects	155
13.1.2	10122.10 PROFIsafe fieldbus	155
13.1.3	10122.2 Encoder type	155
13.1.4	10122.8 Maximum motor speed (n1)	155
13.1.5	10122.9 Minimum motor speed (n2)	156
13.2	F-DI	156
13.2.1	Safety-related digital inputs	156
13.2.2	Diagnostics.....	157
13.3	F-DO	158
13.3.1	10124.6 F-DO-STO line diagnostics	158
13.3.2	10124.9 F-DO-STO test duration (t1).....	158
13.3.3	10124.12 F-DO-STO wire break monitoring	158
13.3.4	10124.2, 10124.3 F-DO0/1 connection type	158
13.3.5	10124.4, 10124.5 F-DO0/1 line diagnostics.....	158
13.3.6	10124.7, 10124.8 F-DO0/1 test duration (t2, t3)	158
13.3.7	10124.10, 10124.11 F-DO0/1 wire break monitoring	159
13.4	STO.....	159
13.4.1	10125.3 STO delay (t1).....	159
13.4.2	10125.2 STO status display delay (t2)	159
13.4.3	10125.4 Permitted coasting time (t3)	159
13.5	SS1	159
13.5.1	10126.2 Function	159
13.5.2	10126.3 SS1c delay (t1).....	160
13.5.3	10126.6 SS1a ramp monitoring delay (t2)	160
13.5.4	10126.5 SS1a ramp time (t3).....	160
13.5.5	10126.7 SS1a distance to ramp (n1)	160
13.5.6	10126.4 SS1a STO function selection delay (t4)	160
13.6	SLS 0, 1, 2, 3	161
13.6.1	10128.2 – 10131.2 Function	161
13.6.2	10128.3 – 10131.3 Limit speed, positive (n1)	161
13.6.3	10128.4 – 10131.4 Limit speed, negative (n1).....	161
13.6.4	10128.5 – 10131.5 Distance to limit speed (n3).....	161

13.6.5	10128.6 – 10131.6 SDI function.....	161
13.7	SLS (general).....	161
13.7.1	10127.4 Ramp monitoring delay (t1).....	161
13.7.2	10127.2 Ramp time (t2).....	162
13.7.3	10127.3 Distance to ramp (n4).....	162
13.7.4	10127.5 Error response to overspeed.....	162
13.7.5	10127.6 Speed filter.....	162
13.7.6	10127.7 SDI tolerance.....	162
13.8	Function assignment.....	163
13.8.1	Safety-related inputs.....	163
13.8.2	Safety-related outputs.....	164
14	Application examples.....	165
14.1	Example 1: Independent operation.....	165
14.2	Example 2: PROFIsafe connection.....	168
15	Technical data.....	171
15.1	Safety characteristics.....	171
15.1.1	Overall component: S12 safety option.....	171
15.1.2	Extended safety class for safety-related digital inputs and outputs.....	172
15.1.3	MOVIFIT® FC.....	173
15.1.4	MOVIFIT® MC.....	173
15.2	Technical data: S12 safety option.....	174
15.2.1	Voltage supply.....	174
15.2.2	Safety-related inputs.....	175
15.2.3	Sensor supply of pulse outputs.....	175
15.2.4	Safety-related outputs.....	176
15.2.5	Encoder interface.....	177
15.2.6	Ambient conditions.....	177
15.3	Technical data MOVIFIT® MC (safety technology).....	178
15.4	Technical data MOVIFIT® FC (safety technology).....	178
	Index.....	179

1 General information

1.1 About this documentation

This documentation is an integral part of the product. The documentation is intended for all employees who perform assembly, installation, startup, and service work on the product.

Make sure this documentation is accessible and legible. Ensure that persons responsible for the machinery and its operation as well as persons who work on the device independently have read through the documentation carefully and understood it. If you are unclear about any of the information in this documentation or require further information, contact SEW-EURODRIVE.

1.2 Structure of the safety notes

1.2.1 Meaning of signal words

The following table shows the grading and meaning of the signal words for safety notes.

Signal word	Meaning	Consequences if disregarded
▲ DANGER	Imminent hazard	Severe or fatal injuries.
▲ WARNING	Possible dangerous situation	Severe or fatal injuries.
▲ CAUTION	Possible dangerous situation	Minor injuries
NOTICE	Possible damage to property	Damage to the drive system or its environment.
INFORMATION	Useful information or tip: Simplifies handling of the drive system.	

1.2.2 Structure of section-related safety notes

Section-related safety notes do not apply to a specific action but to several actions pertaining to one subject. The hazard symbols used either indicate a general hazard or a specific hazard.

This is the formal structure of a safety note for a specific section:



SIGNAL WORD







Type and source of hazard.

Possible consequence(s) if disregarded.

- Measure(s) to prevent the hazard.

Meaning of the hazard symbols

The hazard symbols in the safety notes have the following meaning:

Hazard symbol	Meaning
	General hazard
	Warning of dangerous electrical voltage
	Warning of hot surfaces
	Warning of risk of crushing
	Warning of suspended load
	Warning of automatic restart

1.2.3 Structure of embedded safety notes

Embedded safety notes are directly integrated into the instructions just before the description of the dangerous action.

This is the formal structure of an embedded safety note:

▲ SIGNAL WORD Type and source of hazard. Possible consequence(s) if disregarded. Measure(s) to prevent the hazard.

1.3 Rights to claim under limited warranty

Read the information in this documentation. This is essential for fault-free operation and fulfillment of any rights to claim under limited warranty. Read the documentation before you start working with the unit!

1.4 Content of the documentation

The current version of the documentation is the original.

This document contains additional safety-relevant information and conditions for use in safety-related applications.

1.5 Exclusion of liability

Read the information in this documentation, otherwise safe operation is impossible. You must comply with the information contained in this documentation to achieve the specified product characteristics and performance features. SEW-EURODRIVE assumes no liability for injury to persons or damage to equipment or property resulting from non-observance of these operating instructions. In such cases, SEW-EURODRIVE assumes no liability for defects.

1.6 Other applicable documentation

This manual supplements the existing documentation and limits the application notes according to the information below. Use this manual only together with the following documents:

- "DR.71-225, 315 AC Motors" operating instructions
- "MOVIFIT® FC" and "MOVIFIT® MC" operating instructions
- "MOVIMOT® MM..D" operating instructions
- Manuals for the corresponding function level and fieldbus:
 - "MOVIFIT® Classic Function Level ..."
 - "MOVIFIT® Technology Function Level ..."
- "Safety-Rated Encoders – Functional Safety for AC Motors" addendum

1.7 Product names and trademarks

The brands and product names in this documentation are trademarks or registered trademarks of their respective titleholders.

1.8 Copyright notice

© 2016 SEW-EURODRIVE. All rights reserved. Unauthorized reproduction, modification, distribution or any other use of the whole or any part of this documentation is strictly prohibited.

2 Safety notes

2.1 General information

Never install or operate damaged products. In the event of damage, submit a complaint to the shipping company immediately.

During operation, inverters can have live, bare and movable or rotating parts as well as hot surfaces, depending on their degree of protection.

Removing required covers without authorization, improper use or incorrect installation and operation may result in severe injury to persons, or damage to machinery.

Refer to the documentation for additional information.

2.2 Target group

Any work with the software may only be performed by adequately qualified personnel. Qualified personnel in this context are persons who have the following qualifications:

- Appropriate instruction.
- Knowledge of this documentation and other applicable documentation.
- SEW-EURODRIVE recommends additional product training for products that are operated using this software.

All mechanical work on connected devices is to be performed exclusively by adequately qualified personnel. Qualified personnel in the context of this documentation are persons familiar with the design, mechanical installation, troubleshooting and servicing of the product, who possess the following qualifications:

- Training in mechanical engineering, e.g. as a mechanic or mechatronics technician (final examinations must have been passed).
- Knowledge of this documentation and other applicable documentation.

All electrical work on connected devices is to be performed exclusively by adequately qualified electricians. Qualified electricians in the context of this documentation are persons familiar with electrical installation, startup, troubleshooting and servicing of the product, who possess the following qualifications:

- Training in electrical engineering, e.g. as an electrician or mechatronics technician (final examinations must have been passed).
- Knowledge of this documentation and other applicable documentation.
- Knowledge of the relevant safety regulations and laws.
- Knowledge of all other standards, directives and laws named in this documentation.

The above mentioned persons must have the authorization expressly issued by the company to install, operate, program, configure, label and ground devices, systems and circuits in accordance with the standards of safety technology.

All work in the areas of transportation, storage, operation and waste disposal must be carried out by persons who are trained appropriately.

2.3 Designated use

The S12 safety option is designed for installation in the MOVIFIT® drive controller.

When installed in machines, startup of the S12 safety option (i.e. start of designated operation) is prohibited until it is determined that the machine complies with the local laws and directives. In the individual area of application, you must especially observe the Machinery Directive 2006/42/EC as well as the EMC Directive 2014/30/EU. The EMC test specifications EN 61000-4-2, EN 61000-4-3, EN 61000-4-4, EN 61000-4-6, EN 61000-6-2 and EN 55011 form the basis for this. EN 60204-1 must also be observed.

The S12 safety option is a parameterizable safety controller that can be used to realize safety shutdowns and safety functions. The module can be used as follows:

- In emergency off devices
- As safety component according to Machinery Directive 2006/42/EC
- As PES for risk reduction according to IEC 61508
- In safety circuits according to EN 60204-1 and EN 60204-32
- As PES for functional safety according to IEC 62061
- As SRP/CS according to EN ISO 13849
- As device for implementing the safety functions according to EN 61800-5-2
- As logics device for signal conversion and processing in two-hand control according to EN 574

Observe the technical data and information on the connection requirements as provided on the nameplate and in the documentation.

2.4 Transportation, storage

Observe the notes on transportation, storage and proper handling. Comply with the requirements for climatic conditions stated in chapter "Technical data of S12 safety option".

2.5 Installation

The devices must be installed and cooled as stipulated in the corresponding documentation, see chapter "Other applicable documentation".

Protect the S12 safety option from improper strain. Ensure that components are not deformed and/or insulation spaces are maintained, particularly during transportation. Avoid contact with electronic elements and contacts.

The S12 safety option contains components that can easily be damaged by electrostatic energy and improper handling. Prevent mechanical damage or destruction of electric components (may pose health risk).

The following applications are prohibited unless explicitly permitted:

- Use in potentially explosive atmospheres.
- Use in areas exposed to harmful oils, acids, gases, vapors, dust, radiation, etc.

2.6 Definitions

- The designation F-DI. stands for safety-related input.
The designation F-DO. stands for safety-related output.
The dot "." is a placeholder.
- The designation S12 is used as a generic term for all derivatives of the S12 product series. If a particular derivative is referred to in the manual, then the complete designation is used.
- The term "safe" used in this manual refers to the classification as a safe function according to EN ISO 13849-1.
- PROFIsafe is a technology standard for a safe fieldbus system.
- The "Assist S12" parameterization tool is a user interface for setting the parameters of the S12 safety option.

3 Safety concept

The S12 safety option has been developed and tested according to EN 61800-5-2. This was certified by TÜV Nord. Copies of the TÜV certificate and the corresponding report are available from SEW-EURODRIVE on request.

3.1 MOVIFIT® MC safety concept

3.1.1 MOVIFIT® MC block diagram

The following block diagram shows the MOVIFIT® MC safety concept:

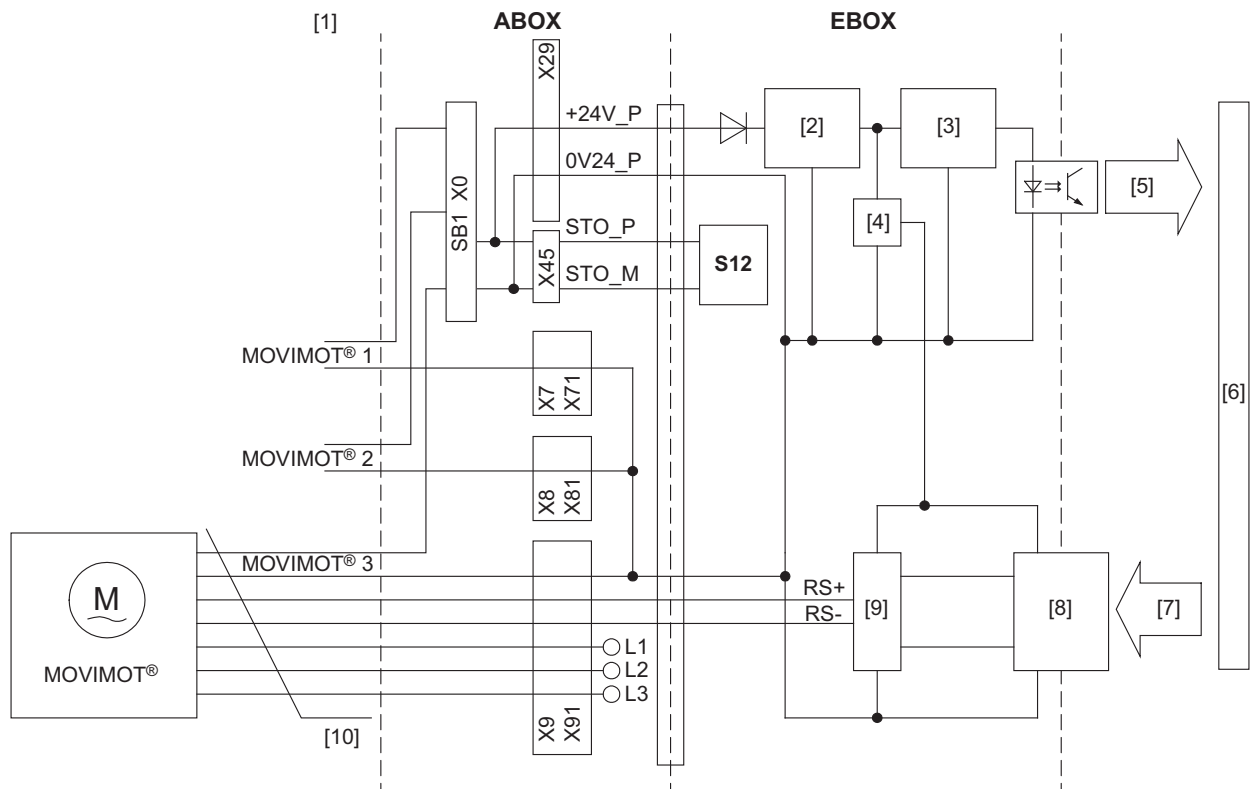

9007209046002443

- [1] Field
- [2] Short-circuit protection
- [3] 24V_P voltage monitor
- [4] Switched-mode power supply
- [5] Voltage status 24V_P
- [6] MOVIFIT® processor
- [7] Serial interface
- [8] Coupler
- [9] Transceiver
- [10] SEW-EURODRIVE hybrid cable

3.1.2 Functional description

The MC design of MOVIFIT® acts as a power distributor and communication interface for controlling up to 3 MOVIMOT® drives. Using the S12 safety option integrated in MOVIFIT® MC, the safety-related 24 V supply voltage (24V_P) of the MOVIFIT® can be switched off to ensure safe torque off. This leads to the switch-off of the supply voltage of the MOVIMOT® drives which is necessary to generate a rotating field in the motor.

The safety-related 24 V supply voltage (24V_P) is connected in the ABOX and fed to the EBOX via a plug strip. The EBOX houses electronic components, such as a short-circuit protection, voltage monitor, RS485 transceiver and coupler. The safety-related 24 V supply voltage (24V_P) is routed through a polarity protection diode at the input of the EBOX. A switch-mode power supply generates 5 V voltage for the RS485 transceiver and the coupler.

In the ABOX, the 24 V supply voltage (24V_P) is additionally routed via the STO load current limit SB1 and forwarded from there directly to the MOVIMOT® drives.

SB1 limits current peaks when the 24 V supply voltage of the MOVIMOT® drives is switched on, and protects the cabling from overload and short circuits.

The STO load current limit SB1 is a mandatory component of the MOVIFIT® MC device with S12 safety option.

The MOVIMOT® MM..D frequency inverter is characterized by the connection option to the S12 safety option. This de-energizes all active elements that generate the pulse trains to the power output stage (IGBT) by switching off the safety-related 24 V supply voltage. This ensures that the frequency inverter no longer supplies power to the motor for generating torque.

Disconnecting the safety-related 24 V supply voltage ensures that the voltage supplies required for operation of the drive are safely interrupted.

MOVIFIT® MC with integrated S12 safety option can be used:

- with Safe Torque Off according to EN 61800-5-2.
- with Safe Stop according to EN 61800-5-2.
- with restart inhibit in accordance with EN 1037.
- in compliance with performance level d according to EN ISO 13849-1.

The MOVIFIT® MC supports stop categories 0 and 1 according to EN 60204-1.

3.1.3 Restrictions



▲ WARNING

Electric shock due to dangerous voltages in the ABOX. If the safety-related 24 V voltage is disconnected, the MOVIFIT® device remains connected to the mains voltage.

Severe or fatal injuries.

- De-energize MOVIFIT®. Observe the minimum switch-off time after disconnection from the supply system:
 - **1 minute**
- The safety concept is only suitable for performing mechanical work on driven system/machine components.
- A system/machine-specific risk assessment must be performed by the system/machine manufacturer and be observed when using MOVIFIT® MC.

3.2 MOVIFIT® FC safety concept

3.2.1 MOVIFIT® FC block diagram

The following block diagram shows the MOVIFIT® FC safety concept:

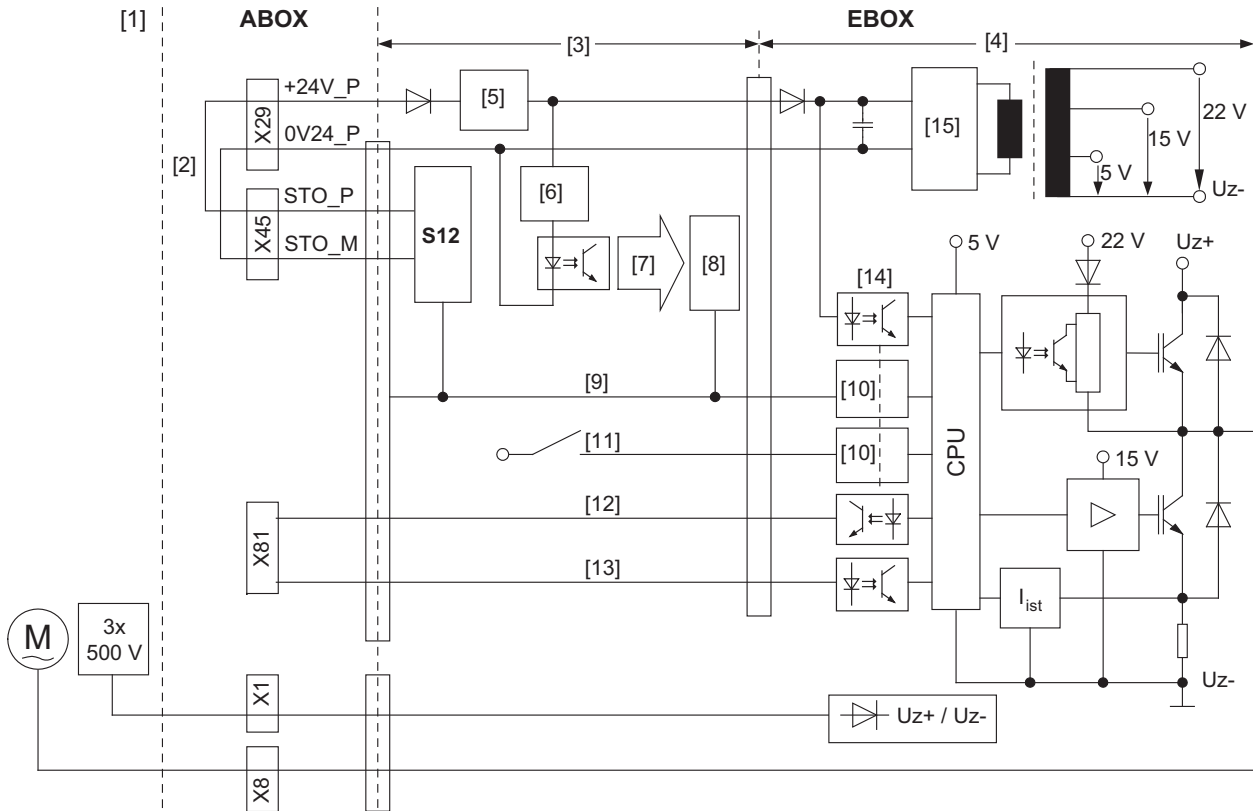

18014407398517899

- [1] Field
- [2] 2 jumpers between X29 and X45
- [3] Control electronics
- [4] Power section
- [5] Short-circuit protection
- [6] 24V_P voltage monitor
- [7] Voltage status 24V_P
- [8] MOVIFIT® processor
- [9] CAN interface
- [10] Coupler
- [11] Read DIP switch
- [12] Digital brake output
- [13] TF/TH evaluation
- [14] 24V_P voltage monitor
- [15] Switched-mode power supply

3.2.2 Functional description

The FC version of MOVIFIT® acts as a power distributor and communication interface with an integrated frequency inverter with a power range of 0.37 to 4 kW. The S12 safety option integrated in MOVIFIT® FC enables switching off the 24 V voltage supply required for generating a rotating field at the inverter output, to ensure that the torque is safely switched off.

The safety-related 24 V voltage supply (24V_P) is connected to terminal X29 in the ABOX and is fed to the control electronics via a plug strip, and to the power section via the direct plug connector. The control electronics and the power section are housed in the EBOX. The safety-related 24 voltage supply (24V_P) is routed through a polarity protection diode at the input of the EBOX. A switched-mode power supply generates a 5 V voltage from the safety-related 24 V supply voltage for the CPU of the power section as well as the supply voltages for the output stage control.

The supply voltages and motor voltages are connected to a terminal strip in the ABOX and fed directly to the power section via a power connector.

The pulse patterns generated in the computer are conditioned in the respective control and relayed to the circuit breaker. If the supply voltages for the controls are switched off, no pulse patterns can be generated at the inverter output.

This kind of disconnection ensures that all active elements required to generate a pulse pattern at the inverter output are switched off.

MOVIFIT® FC with integrated S12 safety option can be used:

- with Safe Torque Off according to EN 61800-5-2.
- with Safe Stop 1 according to EN 61800-5-2
- with restart inhibit in accordance with EN 1037.
- in compliance with performance level d according to EN ISO 13849-1.

MOVIFIT® FC supports stop categories 0 and 1 according to EN 60204-1.

3.2.3 Restrictions



▲ WARNING

Electric shock due to dangerous voltages in the ABOX. If the safety-related 24 V voltage is disconnected, the MOVIFIT® device remains connected to the mains voltage.

Severe or fatal injuries.

- De-energize MOVIFIT®. Observe the minimum switch-off time after disconnection from the supply system:
 - **1 minute**
- The safety concept is only suitable for performing mechanical work on driven system/machine components.
- A system/machine-specific risk assessment must at all costs be carried out by the system/machine manufacturer and be observed when using the MOVIFIT® FC device.

3.3 Safety concept of S12 safety option

- The S12 safety option is an integrated, safety-related electronic assembly that can be operated with or without PROFIsafe connection. It is equipped with safety-related inputs and outputs (F-DI, F-DO). It is available in the following 2 versions.

S12A safety option:

- 4 safety-related inputs
- 1 safety-related 2-channel output F-DO_STO
- 2 safety-related 2-channel outputs

S12B safety option:

- 8 safety-related inputs
- 1 safety-related 2-channel output F-DO_STO
- No other safety-related outputs
- The safety-related output F-DO_STO is used to disconnect the 24 V supply voltage to the inverter, which achieves safety-related stopping of the drive. In this context, observe the safety concept of the MOVIFIT® FC/MC, all conditions, and all installation specifications in this publication.
- The safety concept of this subassembly is based on the fact that there is a safe state for all safety-related process values. For the S12 safety option, this value is "0" for all inputs F-DI and outputs F-DO.
- The system was designed according to IEC 61508 SIL3 and EN ISO 13849-1 Performance Level e.
- In combination with the EI7C FS built-in encoder, the S12 safety option can control and safely monitor movement functions. The standard process data of the inverter are limited by the S12 safety option if the safety function is active. If the maximum speed is exceeded, the F-DO_STO output is used to achieve a safety-related stop of the drive. Program adjustments in the control section are therefore not necessary.

The safety class of the MOVIFIT® basic device determines the safety-related switch-off of the following overall systems:

- **MOVIFIT® MC** with:
 - S12 safety option
 - MOVIMOT® MM..D drive

MOVIFIT® MC may only be used in applications up to Performance Level d according to EN ISO 13849-1.

- **MOVIFIT® FC** with:
 - S12 safety option
 - Motor (group drive not permitted)

MOVIFIT® FC may only be used in applications up to Performance Level d according to EN ISO 13849-1.

3.4 Safety functions

This chapter describes the safety functions according to EN 61800-5-2. Some of the safety functions of the S12 safety option exceed the definitions in the standard.

The following table shows the availability of the drive safety functions described below depending on the respective MOVIFIT® device type.

MOVIFIT® device type	Safety function				
	Standstill			Motion	
	STO	SS1(c)	SS1(a)	SLS	SDI
			only with EI7C FS built-in encoder		
MOVIFIT® FC	x	x	x	x	x
MOVIFIT® MC	x	x			

3.4.1 STO – Safe Torque Off

When the STO function is active, the drive inverter no longer supplies power to the motor. As a result, the drive cannot generate torque. This safety function corresponds to a non-controlled stop according to EN 60204-1, stop category 0.

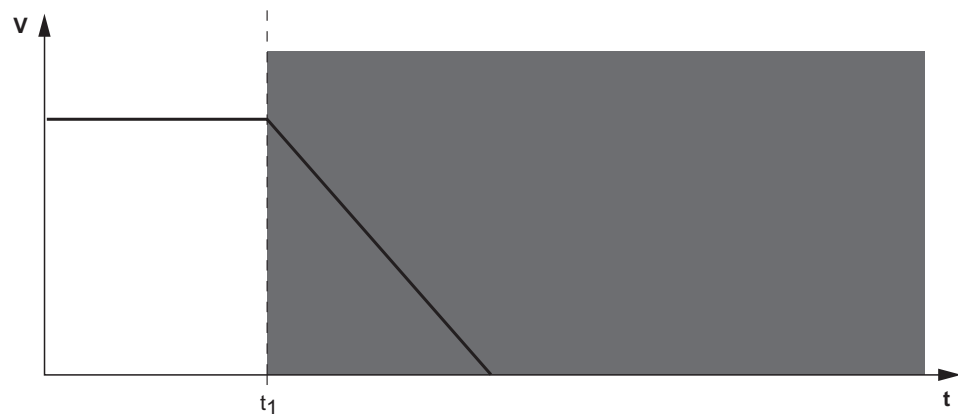

9007201225613323

- = Safety function trips
- v = Speed
- t = Time
- t_1 = Point of time when STO is triggered

INFORMATION



The motor coasts to a halt or is stopped mechanically.
Controlled standstill is preferred, if possible.

3 Safety concept



Safety functions

3.4.2 SS1(a) – Safe Stop 1

When the SS1(a) function is active, the inverter brings the motor to a standstill electrically. The braking operation is controlled and monitored. The safety function STO is triggered when the monitored brake curve is exceeded or when standstill is reached.

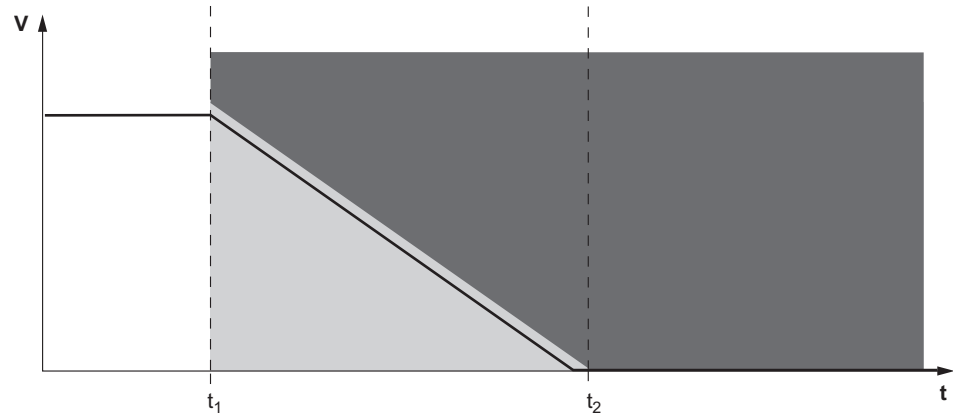
This safety function corresponds to a controlled stop of the drive according to EN 60204-1, stop category 1.



-  Safety function is monitoring
-  Safety function trips

v = Speed

t = Time

t₁ = Point of time when SS1(a) is activated and the braking action is triggered

t₂ = Point of time when STO is triggered

3.4.3 SS1(c) – Safe Stop 1

When the SS1(c) function is active, the inverter brings the motor to a standstill electrically. The STO safety function will be triggered after a specified, safety-relevant time.

This safety function corresponds to a controlled stop of the drive according to EN 60204-1, stop category 1.

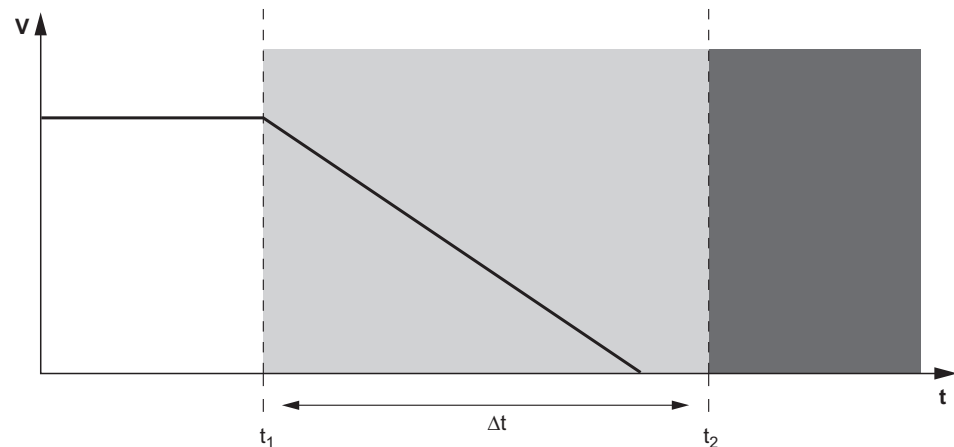

9007201225618443

 = Safety function is monitoring

 = Safety function trips

v = Speed

t = Time

t_1 = Point of time when SS1(c) is activated and motor deceleration is triggered

t_2 = Point of time when STO is triggered.

Δt = Safety-related period of time

INFORMATION



- The SS1(c) function does not monitor the stopping of the drive.
- The safety-related period of time Δt allows the drive to come to a stop. In the event of a fault, the drive does not come to a stop and becomes de-energized at the time t_2 (STO).

3.4.4 SLS – Safely Limited Speed

The SLS function prevents the drive from exceeding a specified velocity. If the permitted velocity is exceeded, the safety function will be triggered and an error response will be initiated (usually STO or SS1).



9007201225702923

- = Safety function is monitoring
- = Safety function trips
- v = Speed
- t = Time
- t₁ = Time when SLS is activated.
- t₂ = Time when SLS is deactivated.

3.4.5 SDI – Safe Direction

The SDI function controls that there is no movement in an unintended direction. If this condition is violated, an error response (STO) is triggered.

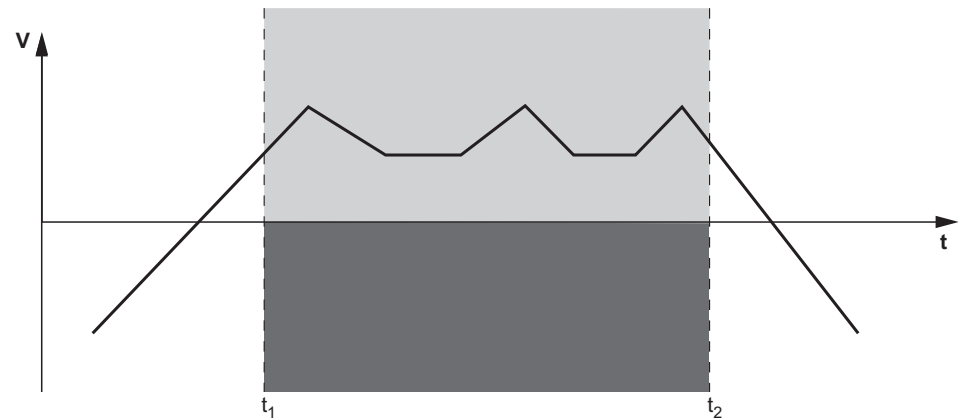

9007201225717643

- Safety function is monitoring
- Safety function trips
- v = Speed
- t = Time
- t₁ = Point of time when SDI is activated
- t₂ = Point of time when SDI is deactivated

3.5 Safety concept of Assist S12

3.5.1 Safety parameters

All safety functions of the S12 safety option can be set via safety parameters (*F-iPar*).

The safety parameters (*F-iPar*) determine the behavior of the corresponding safety function and are therefore safety-relevant. All safety parameters (*F-iPar*) are combined in the *F-iPar* parameter set.

3.5.2 Test concept and test procedure

The parameters of the S12 safety option are set using an engineering PC with the "Assist S12" parameterization tool. As the PC and the "Assist S12" parameterization tool are not safety-related and therefore not error-free, the safety concept requires the following measures:

- Identifying the MOVIFIT® device.
For this, the device serial number must be entered in a dialog box while the connection to the S12 safety option is established.
- Guided parameter setting procedure with the parameterization tool "Assist S12" with integrated safety features such as plausibility check of entries. The user must compare the entered parameters with the device parameters and confirm (verify) them.
- Completing the parameterization by verification of parameters, assisted by the parameterization tool "Assist S12" with subsequent creation of a acceptance protocol for validation of the safety functions.

4 Safety conditions

The following conditions are mandatory for installation and operation of MOVIFIT® in safety-related applications according to the safety concept mentioned above. The conditions are divided into the following sections:

- Nameplate of complete device
- Installation requirements
- Requirements for external sensors and actuators (in combination with S12 safety option)
- Startup requirements
- Operational requirements

4.1 Nameplates

4.1.1 Nameplate position

The following figure shows the positions of the nameplates on the ABOX:

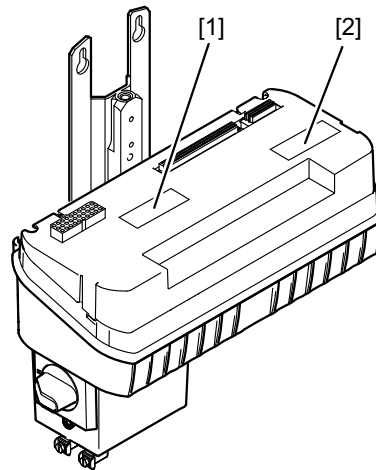

7012396683

- [1] Nameplate of the complete device (EBOX and ABOX)
- [2] Nameplate of the ABOX

4.1.2 Nameplate of complete device

The following figure provides an example of a nameplate of the complete MOVIFIT® FC device (EBOX and ABOX):



8510442251

This nameplate is only available if the EBOX and the ABOX have been ordered as one device.

INFORMATION



Only components marked with the FS logo for functional safety may be installed in safety applications. For combinations of devices without FS logo (consisting of individual EBOX and ABOX), the safety function must be described in the documentation.

4.1.3 Description of FS logo

The following FS logo is printed on the nameplate of the overall MOVIFIT® device:



MOVIFIT® with STO (with or without S11 PROFIsafe option)

For more information about MOVIFIT® with **FS01** logo, refer to the "MOVIFIT® MC / FC – Functional Safety manual".



MOVIFIT® with S12 safety option

For more information about MOVIFIT® with **FS80** logo, refer to this manual.

4.2 Device replacement requirements

INFORMATION



Only components marked with the FS logo for functional safety may be installed in safety applications. For combinations of devices without FS logo (consisting of individual EBOX and ABOX), the safety function must be described in the documentation.

Observe the following device replacement requirements:

- In case of safety-related applications, a defective EBOX may only be replaced by an EBOX according to the type designation on the nameplate of the complete MOVIFIT® device.
- In case of safety-related applications, a defective ABOX may only be replaced by a complete MOVIFIT® device (EBOX and ABOX) with identical type designation.

4.3 Installation requirements

- The wiring technology used must comply with EN 60204-1.
- Observe the values specified for safety components when designing the safety circuits.
- Observe the notes in the "MOVIFIT® MC/FC" and "MOVIMOT® MM..D" operating instructions on EMC compliant cabling.
- For all 24 V supply voltages of the MOVIFIT® device only voltage sources with safe disconnection (SELV/PELV) according to EN 60204-1 and EN 61131-2 are permitted. In case of a single fault, the voltage between the outputs or between any output and grounded parts may not exceed DC 60 V.
- Observe the technical data of MOVIFIT® and MOVIMOT® MM..D.

Note the additional requirements in connection with the EI7C FS built-in encoder:

- When connecting an EI7C FS built-in encoder to the MOVIFIT® device, the encoder cable must not carry a TF signal.
- When using an EI7C FS built-in encoder together with application modules, the digital inputs DI04 – DI07 at the X25 terminal of the application module may not be used at all, or as encoder inputs only.

4.4 External sensors and actuators – requirements

- The project planner and the operator of the system or machine are responsible for the selection and use of external sensors and actuators to connect to the safety-related inputs and outputs of the S12 safety option.
- Use the calculation tool "SISTEMA" from the "IFA" (Institute for Occupational Safety and Health of the German Social Accident Insurance) for selecting a suitable sensor technology and suitable actuators.
- To meet the required Performance Level (PL)/SIL, you have to use suitable and qualified sensors and actuators, and observe the relevant wiring diagrams and notes in chapter "Safety-related inputs" (→ 43) and "Safety-related outputs" (→ 51).

4.5 Startup requirements

After parameterization and startup, the startup engineer has to check and document the correct performance of the safety functions.

For MOVIFIT® applications with safety-related disconnection of the drive

- with Safe Torque Off according to EN 61800-5-2
- with Safe Stop according to EN 61800-5-2
- in stop category 0 or 1 in accordance with EN 60204-1,
- with restart inhibit in accordance with EN 1037
- and compliance with Performance Level d according to EN ISO 13849-1,

startup checks of the disconnecting device and the correct wiring must always be carried out and documented.

When these functions are changed or additional safety functions are activated, validate them according to EN ISO 13849-2.

This is supported by the "Assist S12" parameterization tool with a acceptance protocol.

INFORMATION



The insert labels of the MOVIFIT® EBOXes are assigned to the respective EBOX. If you take out the labels to mark them, make sure that they are re-inserted in the right EBOX.

To avoid danger in the application, the user has to check whether the error response time of each safety function (when a failure occurs) is shorter than the maximally permitted error response time of the application. The maximally permitted error response time may not be exceeded!

5 Hazard caused by a coasting drive



▲ WARNING

Hazard caused by coasting of the drive without mechanical brake or if the brake is faulty, the drive might coast to a halt.

Severe or fatal injuries.

- If coasting the drive to a halt results in application-dependent hazards, take additional protective measures (for example, guards with locking device), which cover the hazardous area until persons are no longer in danger. As an alternative, you must equip the drive with a safety brake.
- The additional protective covers must be designed and integrated so that they meet the requirements determined in the risk assessment for the machine.
- After activating the stop command, access to the machine must remain blocked until the drive has reached standstill according to the risk. As an alternative, you must determine the access time and calculate the resulting safety clearance that must be adhered.

6 Electrical installation

6.1 Installation instructions

To guarantee electrical safety and fault-free operation, you must observe the general installation instructions and the notes in the MOVIFIT® operating instructions.



▲ WARNING

Only the types of connection described in this publication may be used.

Severe or fatal injuries.

- Any different types of connection specified in other publications are not permissible.

6.2 Safe disconnection MOVIFIT®

6.2.1 MOVIFIT® MC

STO load current limit (SB1) and terminals

The following figure shows the STO load current limit (SB1) [2] and the printed circuit board [1] with terminals in the ABOX of a MOVIFIT® MC.

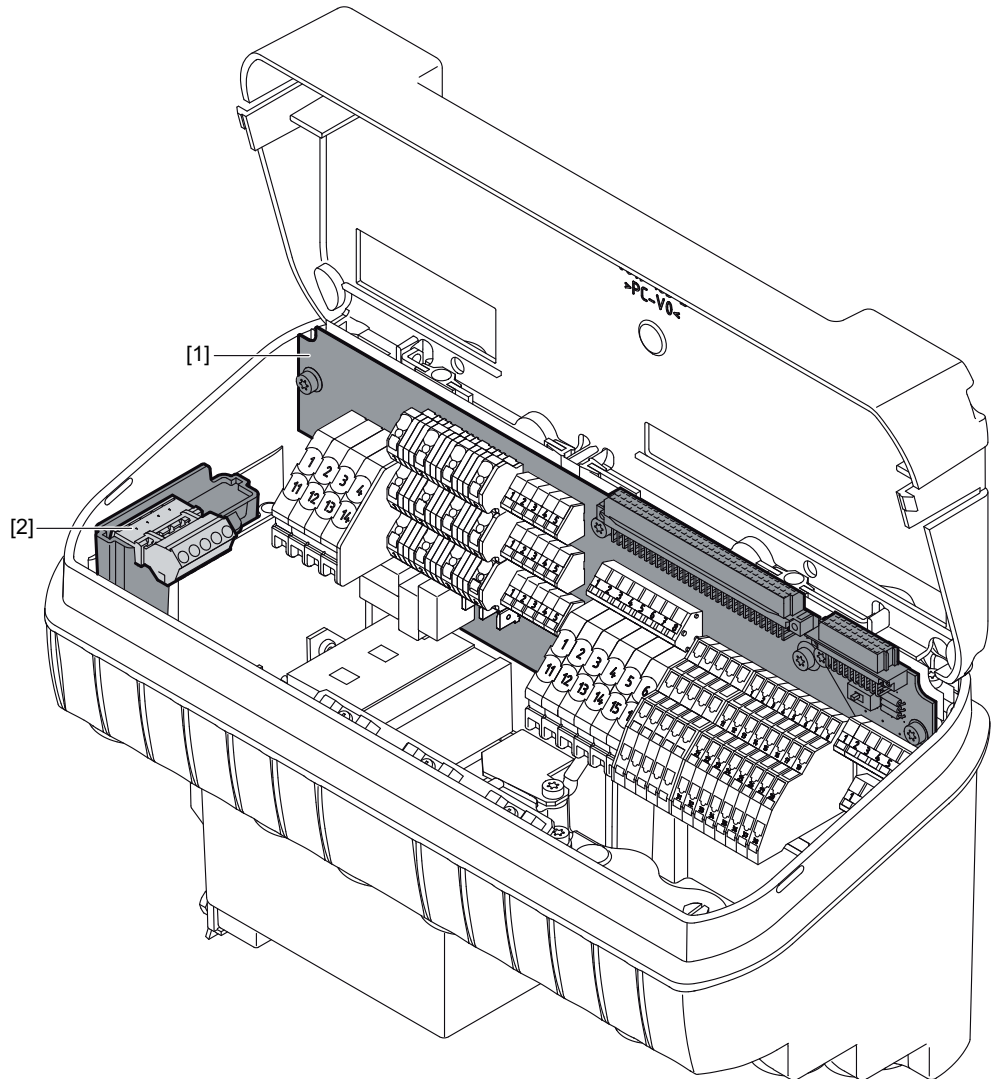

9007211271211275

- [1] Printed circuit board with terminals
- [2] STO load current limit (SB1)

Terminals relevant for safe torque off

The following figure depicting the standard ABOX "MTA...-S01.-...-00" shows the terminals relevant for Safe Torque Off of MOVIFIT® MC with the STO load current limit (SB1).

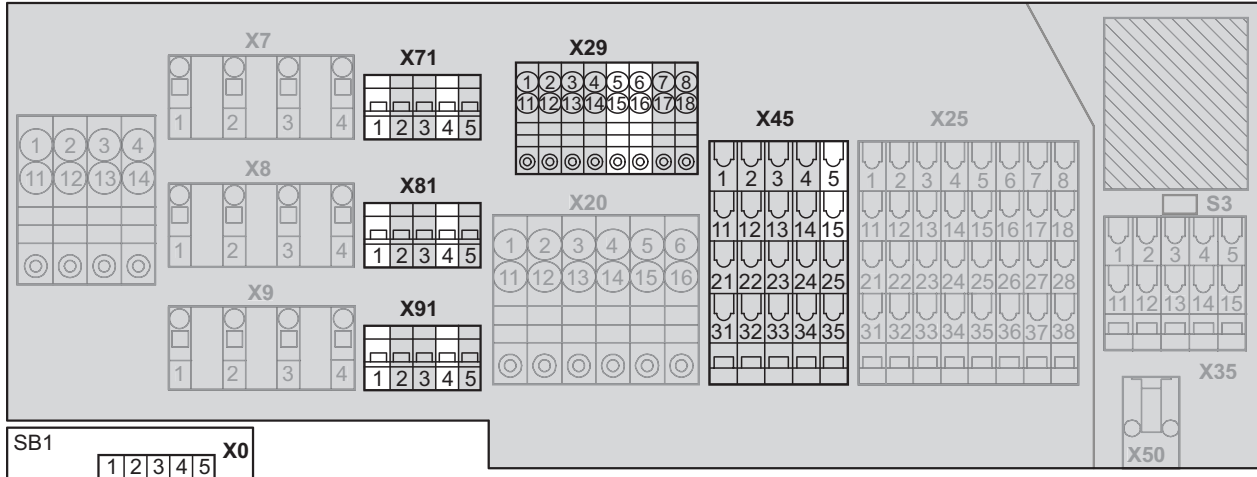

9792220427

Terminal strip	Name	Function
X29/5	+24V_P	Safety-related +24 V supply voltage (IN) +24 V supply (IN) Jumper to X45/5 (delivery state)
X29/6	0V24V_P	Reference potential safety-related 24 V supply voltage 0V24 reference potential (IN), Jumper to X45/15 (delivery state)
X29/15	+24V_P	Safety-related 24 V supply voltage +24 V supply (OUT) Jumper to SB1 X0/1 (delivery state)
X29/16	0V24V_P	Reference potential safety-related 24 V supply voltage 0V24 reference potential (OUT) Jumper to SB1 X0/2 (delivery state)
X71/1, X71/4 X81/1, X81/4 X91/1, X91/4	0V24V_MM	STO output 0V24 reference potential safety-related 24 V 0V24 reference potential MOVIMOT® 1 to 3
X45/5	F-DO_STO_P	Safety-related output F-DO_STO (sourcing signal) for Safe Torque Off in the drive (STO) Jumper to X29/5 (delivery state)
X45/15	F-DO_STO_M	Safety-related output F-DO_STO (sinking signal) for Safe Torque Off in the drive (STO) Jumper to X29/6 (delivery state)

22865268/EN – 06/2016

Terminal X0 (SB1)	Name	Function
X0/1	STO_P	STO input reference potential safety-related 24 V supply voltage Connection to X29/15 (delivery state)
X0/2	STO_M	STO input 0V/24 reference potential safety-related 24 V supply voltage Connection to X29/16 (delivery state)
X0/3	STO_P_OUT	STO output safety-related 24 V supply voltage +24 V supply voltage MOVIMOT® 1 (+24V_MM)
X0/4	STO_P_OUT	STO output safety-related 24 V supply voltage +24 V supply voltage MOVIMOT® 2 (+24V_MM)
X0/5	STO_P_OUT	STO output safety-related 24 V supply voltage +24 V supply voltage MOVIMOT® 3 (+24V_MM)

Wiring diagram for MOVIFIT® MC with S12 safety option for safety-related disconnection

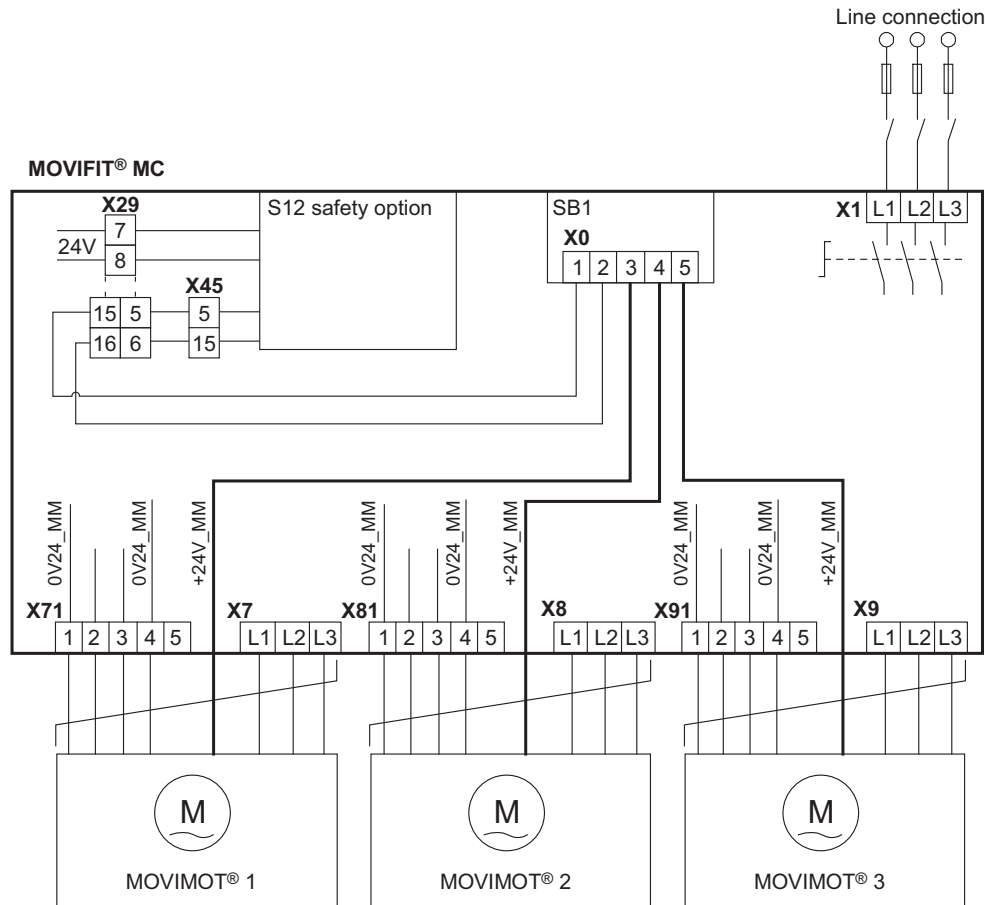

18014406981369995

▲ WARNING



The safety-related disconnection of MOVIFIT® MC is only permitted for applications up to Performance Level d according to EN ISO 13849-1.

Severe or fatal injuries.

- Observe the relevant "Safety concept" (→ 15) as well as the "Safety requirements" (→ 26).
- The safety functions must be verified and documented during startup.

6

Electrical installation

Safe disconnection of MOVIFIT®

6.2.2 MOVIFIT® FC

Terminals relevant for Safe Torque Off

The following figure depicting the standard ABOX "MTA...-S02-...-00" shows the terminals relevant for safe disconnection of MOVIFIT® FC.

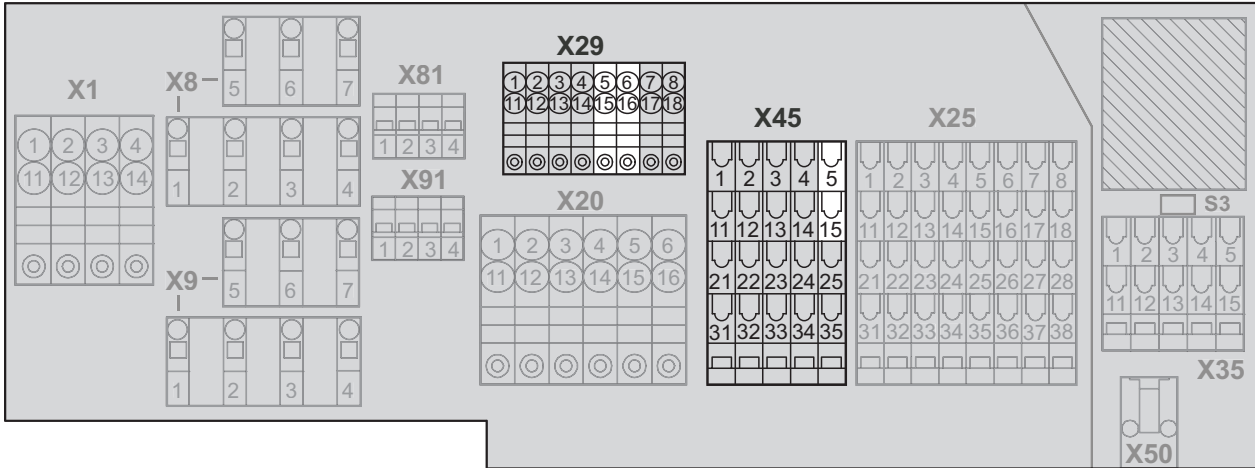

9007203349349131

Terminal strip	Name	Function
X29/5	+24V_P	Connection of safety-related 24 V supply voltage +24V supply for integrated frequency inverter
X29/6	0V24_P	Connection of safety-related 24 V supply voltage 0V24 reference potential for integrated frequency inverter
X29/15	+24V_P	Connection of safety-related 24 V supply voltage +24V supply for integrated frequency inverter
X29/16	0V24_P	Connection of safety-related 24 V supply voltage 0V24 reference potential for integrated frequency inverter

Terminal strip	Name	Function
X45/5	F-DO_STO_P	Safety-related digital output F-DO_STO (sourcing signal) for Safe Torque Off in the drive (STO)
X45/15	F-DO_STO_M	Connection of safety-related 24 V supply voltage Safety-related digital output F-DO_STO (sinking signal) for Safe Torque Off in the drive (STO)

22865268/EN – 06/2016

Wiring diagram for MOVIFIT® FC with S12 safety option for safety-related disconnection

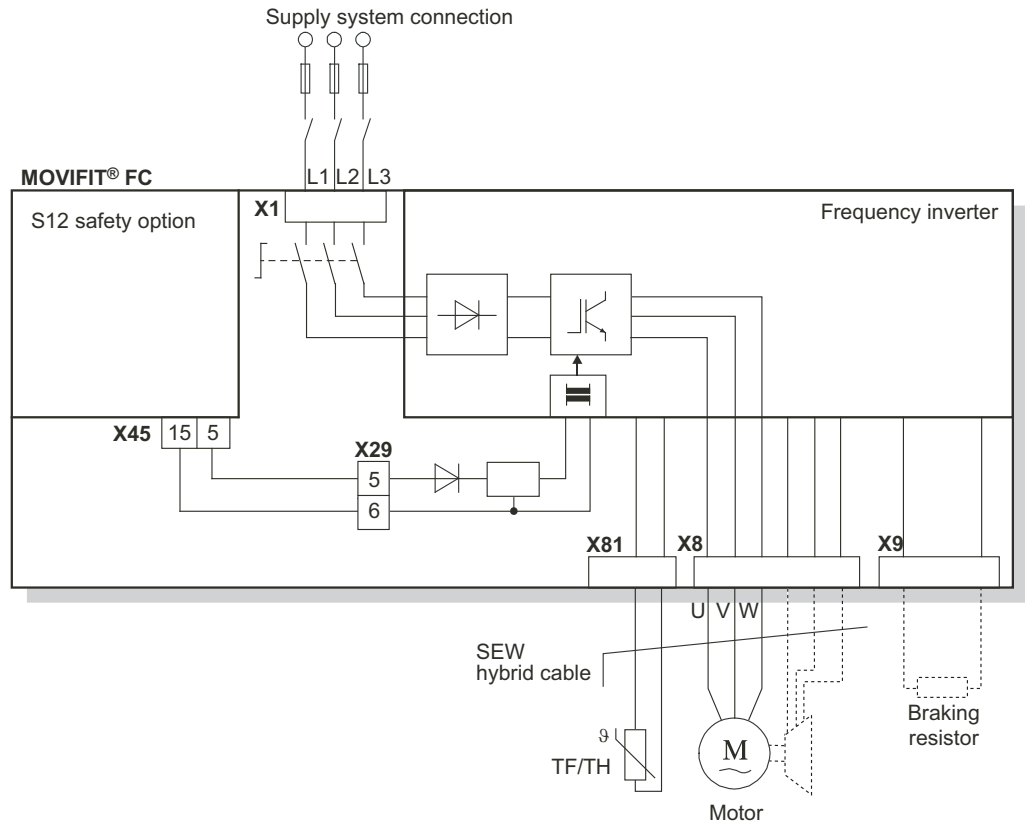

9007207726662539

Safety-related disconnection

The following wiring diagram shows the wiring to ensure the safety-related disconnection of the MOVIFIT® FC drive.

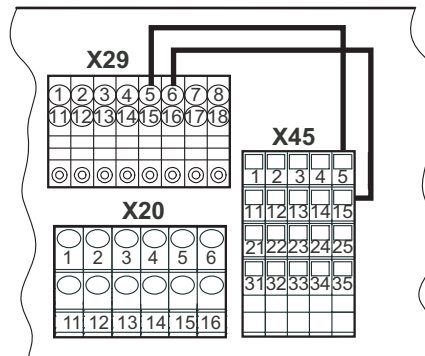

9007203349743243



▲ WARNING

The safety-related disconnection of the power section of MOVIFIT® FC is only permitted for applications up to Performance Level d according to EN ISO 13849-1.

Severe or fatal injuries.

- Observe the relevant "Safety concept" (→ 15) as well as the "Safety requirements" (→ 26).
- The safety functions must be verified and documented during startup.

6.2.3 Voltage supply of the S12 safety option

The following wiring diagram shows the voltage supply of the S12 safety option via terminal X29. The electronics and sensor voltage 24V_C is used for this purpose.

For detailed information on supplying the electronics and sensor voltage 24V_C refer to chapter "Power bus connection examples" in the "MOVIFIT® FC" and "MOVIFIT® MC" operating instructions.

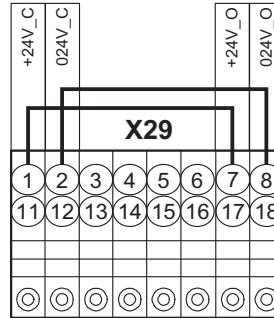

18258535691

INFORMATION



SEW-EURODRIVE recommends using the 24V_C electronics and sensor voltage to supply the S12 safety option. Alternatively, always switch the 24V_O option voltage supply and the 24V_C voltage on and off together.

Otherwise, this might cause faults and error messages in the communication with the safety controller, as the 24V_O voltage supplies the entire safety electronics of the S12 safety option. If 24V_O is switched off, the PROFIsafe station is missing in the network.

6 Electrical installation

S12 safety option

6.3 S12 safety option

6.3.1 Terminal assignment

The following connection terminals are relevant for operating the S12 safety option. The following figures show an example of the connection board for MOVIFIT® FC.

X29: 24 V distributor terminals

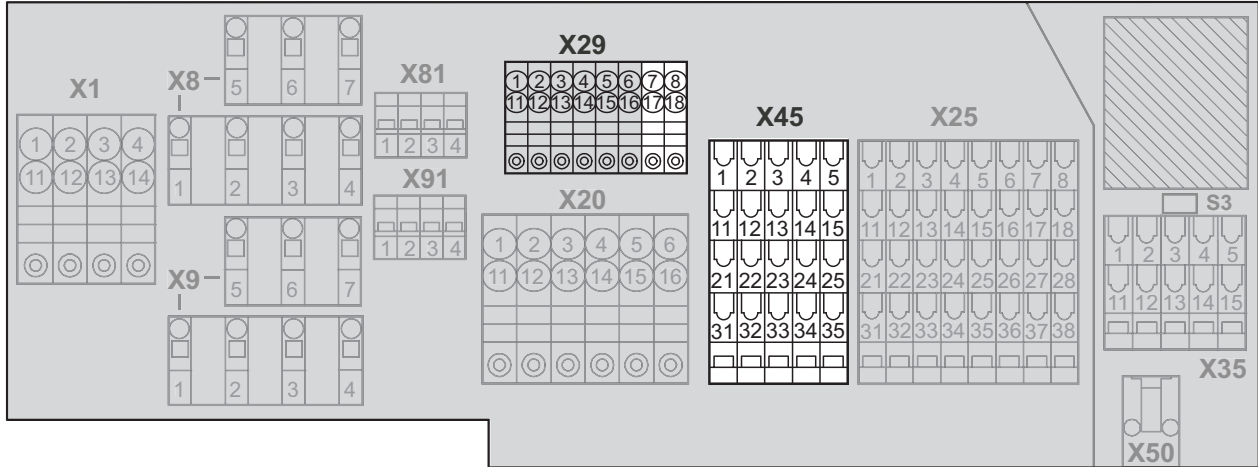

4094748427

Distributor terminal 24 V (for distributing the supply voltage to the option card)			
No.		Name	Function
X29	7	+24V_O	+24 V supply for option card.
	8	0V24_O	0V24 reference potential for option card.
	17	+24V_O	+24 V supply for option card.
	18	0V24_O	0V24 reference potential for option card.

X45: I/O terminals for safety-related inputs/outputs with S12A safety option

I/O terminals for safety-related inputs/outputs (only in connection with S12A safety option)			
No.	Name	Function	
X45	1	F-DI00	Safety-related digital input F-DI00 (switching signal).
	2	F-DI02	Safety-related digital input F-DI02 (switching signal).
	3	F-DO00_P	Safety-related digital output F-DO00 (sourcing signal).
	4	F-DO01_P	Safety-related digital output F-DO01 (sourcing signal).
	5	F-DO_STO_P	Safety-related digital output F-DO_STO (sourcing signal) for Safe Torque Off in the drive (STO).
	11	F-DI01	Safety-related digital input F-DI01 (switching signal).
	12	F-DI03	Safety-related digital input F-DI03 (switching signal).
	13	F-DO00_M	Safety-related digital output F-DO00 (sinking signal).
	14	F-DO01_M	Safety-related digital output F-DO01 (sinking signal).
	15	F-DO_STO_M	Safety-related digital output F-DO_STO (sinking signal) for Safe Torque Off in the drive (STO)
	21	F-SS0	+24 V sensor supply for safety-related inputs F-DI00 and F-DI02
	22		
	23	F-SS1	+24 V sensor supply for safety-related inputs F-DI01 and F-DI03
	24		
	25		
	31	0V24_O	0V24 reference potential for safety-related inputs/outputs.
	32		
	33		
	34		
	35		

X45: I/O terminals for safety-related inputs/outputs with S12B safety option

I/O terminals for safety-related inputs/outputs (only in connection with S12B safety option)			
No.	Name	Function	
X45	1	F-DI00	Safety-related digital input F-DI00 (switching signal).
	2	F-DI02	Safety-related digital input F-DI02 (switching signal).
	3	F-DI04	Safety-related digital input F-DI04 (switching signal)
	4	F-DI06	Safety-related digital input F-DI06 (switching signal)
	5	F-DO_STO_P	Safety-related digital output F-DO_STO (sourcing signal) for Safe Torque Off in the drive (STO).
	11	F-DI01	Safety-related digital input F-DI01 (switching signal).
	12	F-DI03	Safety-related digital input F-DI03 (switching signal).
	13	F-DI05	Safety-related digital input F-DI05 (switching signal)
	14	F-DI07	Safety-related digital input F-DI07 (switching input)
	15	F-DO_STO_M	Safety-related digital output F-DO_STO (sinking signal) for Safe Torque Off in the drive (STO)
	21	F-SS0	+24 V sensor supply for safety-related inputs F-DI00, F-DI02, F-DI04 and F-DI06.
	22		
	23	F-SS1	+24 V sensor supply for safety-related inputs F-DI01, F-DI03, F-DI05 and F-DI07.
	24		
	25		
	31	0V24_O	OV24 reference potential for safety-related inputs/outputs.
	32		
	33		
	34		
	35		

6.3.2 Safety-related inputs (F-DI.)

The safety-related inputs (F-DI.) are connected at terminal X45. The following sections explain and describe the permitted connection options.

The safety-related inputs are processed in 2-channel mode in the S12 safety option. The safety-related inputs are therefore suitable for applications up to SIL 3 according to IEC 61508 and Performance Level e according to EN ISO 13849-1. The external sensors and their wiring must comply with the required safety class.

Note the wiring diagrams below. In addition, observe the "Sensor and actuator requirements" (→ 28).

Unassigned inputs need not be wired. An open input is always read as a "0" signal.

Pulsed voltage supply and crossfault monitoring

For information about parameter setting and operating principles, refer to chapter "Startup".

If crossfault monitoring is active for a safety-related input F-DI, the following assignment between the sensor supply F-SS and the safety-related input F-DI must be adhered to:

- F-DI00, F-DI02, F-DI04 (S12B only), F-DI06 (S12B only) via the respective sensor to F-SS0
- F-DI01, F-DI03, F-DI05 (S12B only), F-DI07 (S12B only) via the respective sensor to F-SS1

Crossfault monitoring can be selected separately for each input.

If crossfault monitoring is not active (e.g. for sensors with OSSD output), the sensors can be supplied by F-SS0 / F-SS1 or by another +24 V supply that has the same ground reference as 24V_O. If 24V_O and 24V_C are jumpered (X29), you can use the sensor supply of terminal X25.

The safety-related inputs do not require shielded cables.

▲ WARNING



Danger due to incorrect setting of parameter *F-DI. connection type* when connecting 2-channel sensors. With the setting "1-channel", there is no redundancy or discrepancy check.

Severe or fatal injuries.

- When connecting 2-channel sensors, you must set the parameter *F-DI. connection type* to "2-channel (non-equivalent/equivalent)".

Only the connection variants shown below are permitted in safety-related applications. Also note the assignment of connection options of the safety-related inputs to the category structure according to EN ISO 13849-1.

a) Sensors with contact (1-channel)

A 1-channel sensor is connected via the sensor supply F-SS0 or F-SS1. This allows for crossfaults in the wiring to be detected. Note the detailed assignment of F-DI. to the sensor supply F-SS0 or F-SS1 in chapter "Terminal assignment".

Settings in the parameterization tool "Assist S12":

- Choose the 1-channel connection type.
- Activate or deactivate "crossfault monitoring and pulsed sensor supply" (→ 43), depending on the safety requirements.

The following figure shows the S12 safety option with 1-channel sensors with contacts.

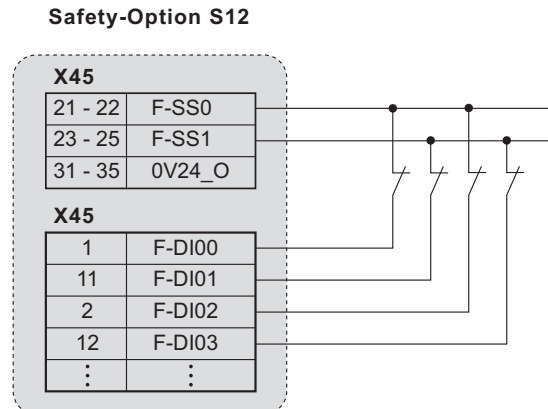

8411741579

Operation with activated crossfault monitoring

The following errors are detected:

- Crossfaults between the digital input and a 24 V supply voltage
- Crossfaults between the digital input and the sensor supply that is **not** assigned to the input, and all input lines connected to this sensor supply.

▲ WARNING



The S12 safety option **cannot** detect a short circuit between a F-SS. sensor supply and a corresponding safety-related input F-DI. (bridging the sensor).

Severe or fatal injuries.

- Make sure that a short circuit between the sensor supply F-SS. and a corresponding safety-related input F-DI. is not possible.

▲ WARNING



If crossfault monitoring is deactivated, the S12 safety option **cannot** detect crossfaults in the wiring. This configuration is **not** permitted for safe applications without further measures.

Severe or fatal injuries.

- A 1-channel sensor with crossfault monitoring can achieve a category 2 structure according to EN ISO 13849-1.

b) Sensors with contact (2-channel)

A 2-channel sensor with contacts is connected via the sensor supply F-SS0 and F-SS1. Note the detailed assignment of F-DI. to the sensor supply F-SS0 and F-SS1 in chapter "Terminal assignment".

Settings in the parameterization tool "Assist S12":

- Choose the 2-channel connection type.
- Activate or deactivate crossfault monitoring and pulsed sensor supply, depending on the safety requirements.
- Set the permitted discrepancy time between the two input signals of the sensor you are using.

22865268/EN – 06/2016

The following figure shows the S12 safety option with 2-channel sensors with contacts in the connection variants "non-equivalent" and "equivalent".

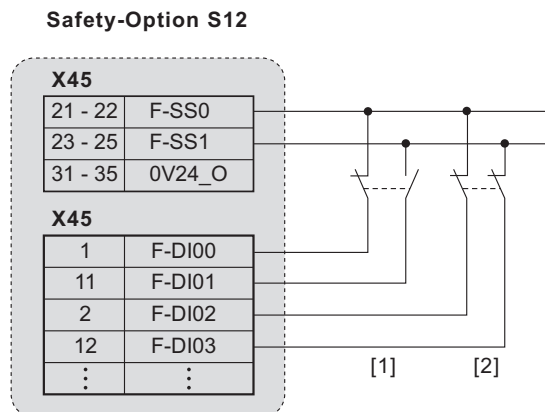

8411745035

[1] Non-equivalent

[2] Equivalent

Operation with activated crossfault monitoring

The following errors are detected:

- Crossfault between a digital input and a 24 V supply voltage
- Crossfault between the two digital inputs of an input pair.

Operation without crossfault monitoring

When using a 2-channel, non-equivalent sensor, the S12 safety option can detect a crossfault between the two digital inputs of an input pair.

▲ WARNING



The S12 safety option cannot detect a short circuit between a F-SS. sensor supply and a corresponding safety-related input F-DI. (bridging the sensor).

Severe or fatal injuries.

- Make sure that a short circuit between the sensor supply F-SS. and a corresponding safety-related input F-DI. is not possible.

▲ WARNING



If crossfault monitoring is deactivated and a 2-channel, equivalent-switching sensor is used, the S12 safety option **cannot** detect crossfaults in the wiring.

Severe or fatal injuries.

- Make sure that crossfaults are not possible at the safety-related inputs F-DI.



INFORMATION

- Both connection variants, implemented as 2-channel sensor (equivalent or non-equivalent), can achieve a **category 3 structure** according to EN ISO 13849-1 **without crossfault monitoring**.
 - Both connection variants, implemented as 2-channel sensor (equivalent or non-equivalent), can achieve a **category 3 structure** according to EN ISO 13849-1 **without crossfault monitoring**.
 - Note that in the non-equivalent connection variant, the NC contact is connected to the sensor supply F-SS0.
-

c) Active sensors (2-channel)

When connecting a 2-channel sensor with additional voltage supply, the voltage is supplied via the respective pins of terminal X25. The voltage supplies for the sensor outputs are connected to the sensor supply F-SS0 and F-SS1. The safety-related outputs of the sensor are connected with 2 channels to the respective inputs F-DI. at terminal X45.

Note the detailed assignment of F-DI. to the sensor supply F-SS0 and F-SS1 in chapter "Terminal assignment".

Settings in the parameterization tool "Assist S12":

- Choose the 2-channel connection type (equivalent/non-equivalent).
- Activate or deactivate the pulsed sensor supply, depending on the safety requirements.
- Parameterize the permitted discrepancy time between the two input signals of the sensor you are using.

The following figure shows the S12 safety option with active sensor (2-channel).

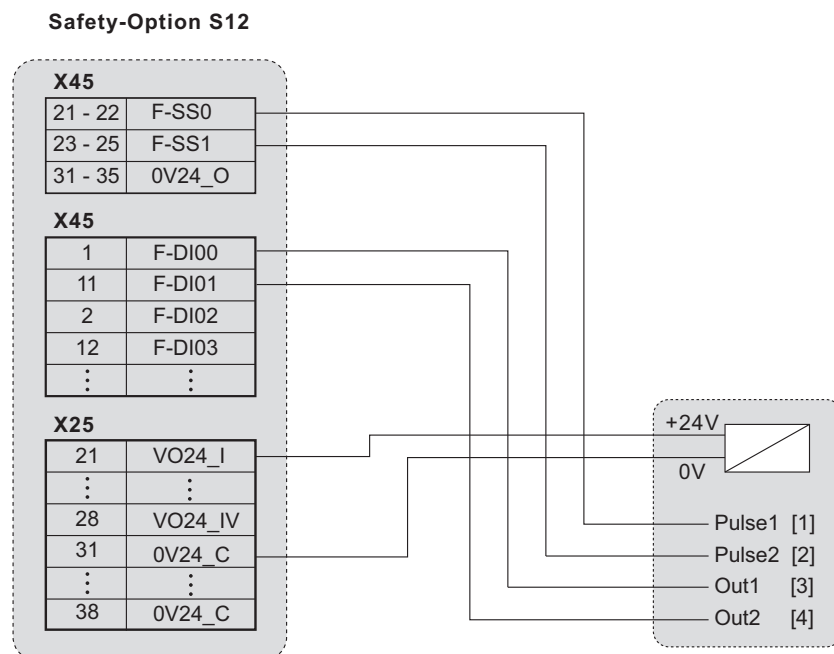

8411749259

- [1] Supply of output 1 (Out1)
- [2] Supply of output 2 (Out2)
- [3] Safety-related digital output 1
- [4] Safety-related digital output 2

Operation with activated crossfault monitoring

The following errors are detected:

- Crossfault between a digital input and a 24 V supply voltage
- Crossfault between the two digital inputs of an input pair.



▲ WARNING

The S12 safety option cannot detect a short circuit between a F-SS. sensor supply and a corresponding safety-related input F-DI. (bridging the sensor).

Severe or fatal injuries.

- Make sure that a short circuit between the sensor supply F-SS. and a corresponding safety-related input F-DI. is not possible.



▲ WARNING

If crossfault monitoring is deactivated, the S12 safety option **cannot** detect crossfaults in the wiring.

Severe or fatal injuries.

- Make sure that crossfaults are not possible at the safety-related inputs F-DI., or that they can be detected by the sensor.



INFORMATION

- Both connection variants, implemented as 2-channel sensor (equivalent or non-equivalent), can achieve a **category 3 structure** according to EN ISO 13849-1 **without crossfault monitoring**.
- Both connection variants, implemented as 2-channel sensor (equivalent or non-equivalent), can achieve a **category 3 structure** according to EN ISO 13849-1 **without crossfault monitoring**.

The S12 safety option must be supplied by the electronics and sensor voltage 24V_C, see chapter "Connection example for power bus" in the "MOVIFIT® FC" and "MOVIFIT® MC" operating instructions.

d) Sensors with semiconductor outputs (OSSD, 2-channel)

When connecting an OSSD sensor, make sure that pulsed voltage supply is deactivated.

INFORMATION



Deactivate the crossfault monitoring at the respective safety-related inputs if the OSSD-capable sensor technology.

OSSD-capable sensor technology tests and diagnoses the OSSD outputs on its own. The faults detected in the wiring depend on the diagnostic function of the used sensor.

For OSSD sensors, the following two connection variants are possible (examples):

Connection variants 1

If sensors with contact are used in addition to sensors with OSSD-capable outputs and if the sensors with contact require crossfault monitoring, the OSSD-capable sensors can be supplied via the respective connections of the terminal X25.

Safety-Option S12

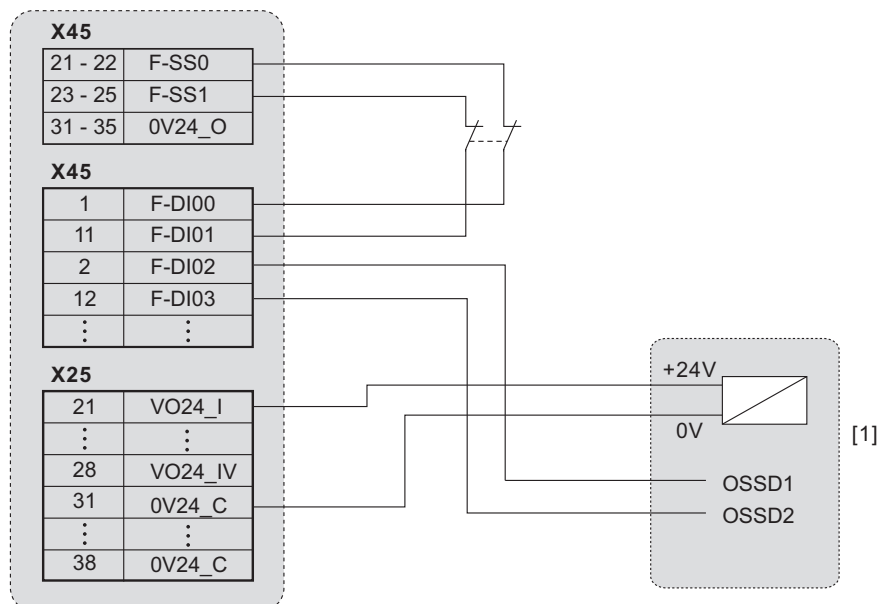

8411757835

[1] OSSD sensor (e.g. scanner or light grid)

The S12 safety option must be supplied by the electronics and sensor voltage 24V_C, see chapter "Connection example for power bus" in the "MOVIFIT® FC" and "MOVIFIT® MC" operating instructions.

Connection variants 2

If only OSSD sensors are used, the voltage can also be supplied via terminals F-SS0 and F-SS1.

Settings in the parameterization tool "Assist S12":

- In this case, deactivate the pulsed sensor supply (F-SS0 and F-SS1).

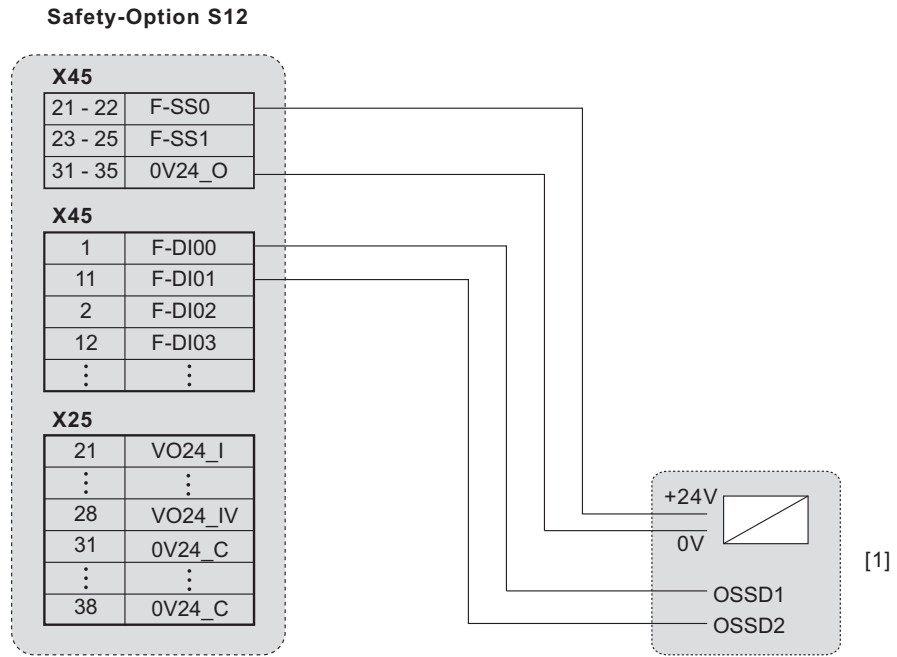

[1] OSSD sensor (e.g. scanner or light grid)

INFORMATION



The achievable Performance Level is mainly determined by the OSSD sensors used. Use the voltage supply of the terminal X25 for sensors that have a higher current consumption than the sensor supply F-SS. can supply.

6.3.3 Safety-related outputs (F-DO. and F-DO_STO)

General information

The safety-related outputs are processed in 2-channel mode within the S12 safety option. The safety-related outputs can therefore achieve SIL 3 according to IEC 61508 and Performance Level e according to EN ISO 13849-1. The external actuators and their wiring must comply with the required safety class.

The safety-related outputs (F-DO. and F-DO_STO) are connected to terminal X45.

The actuators are connected to the safety-related output F-DO_STO via 2 poles, sourcing/sinking output. Other connection variants are not permitted.

The actuators can be connected to the safety-related outputs F-DO00 and F-DO01 (only available with S12A variant) via 2 poles, sourcing/sinking output, or via 1 pole, sourcing output.

- Set the respective configuration during startup using the parameterization tool "Assist S12" (→  100).

1-pole, sinking digital outputs are not permitted.

The safety-related digital outputs do not require shielded cables.

Note that the achievable Performance Level (PL) and SIL depend on the selected connection variant for the safety-related outputs.

Information about permitted loads

The connectable loads are subject to the following restrictions:

Control of safe torque off of the inverter

- MOVIFIT® FC: Disconnection of the safety-related 24 V supply voltage of the power section (24V_P at X29).

Each safety-related output of the S12 safety option may control maximally 1 power section of the MOVIFIT® FC inverter.

- MOVIFIT® MC: Disconnection of the safety-related 24 V supply voltage to switch-off the lower level MOVIMOT® devices.

Only the safety-related output F-DO_STO of the S12 safety option may control the lower level MOVIMOT® devices via the load current limit SB1. The STO load current limit (SB1) must be used between the safety-related output F-DO_STO of the S12 safety option and the MOVIMOT® devices.

In addition to the control of the 24 V supply voltage (24V_P) of the inverter, ohmic and inductive loads can be connected. However, you may not connect capacitive loads. The current consumption of the additional load must not exceed 100 mA.

Capacitive loads

- Without any additional measures, a capacitive load of no more than 130 µF may be connected to the output. Capacitive loads often occur in electronic assemblies as buffer capacitors.

The capacitive load must be equipped with a diode in series with the output. This is often installed as polarity protection diode in electronic assemblies.

- If the capacitive load is not known, or higher than 130 µF, the inrush current must be limited to the permitted values of the output according to EN 61131-2.



INFORMATION

Maximum switching frequency of the outputs.

- Due to the thermal load of output components, the values for the switching frequency of the outputs specified in chapter "Safety-related outputs" (→ 176) must be observed with capacitive loads.

Inductive loads

Inductive loads are, for example, relays, contactors, valves.

- Inductive loads always have to be connected between sourcing and sinking outputs.
- The energy stored in the load inductance, which depends on the inductance value and the current, may not exceed the values specified in chapter "Technical data".

NOTICE

Operation of inductive loads without flyback diode can damage the S12 safety option.

Damage to the S12 safety option.

- Inductive loads must always be connected via a freewheeling diode. The safety-related outputs of the S12 safety option are not equipped with flyback diodes.
- Varistors and other overvoltage protection elements are not permitted.

Ohmic loads

Ohmic loads for example are lamps.

- Lamps can be connected to display statuses. Note that when using incandescent lamps or halogen lamps, an increased cold current flows when they are switched on. The cold current must not exceed the permitted output current according to EN 61131-2.

Information about line diagnostics and test pulses

Short voltage pulses are added to the output signals to monitor the wiring. This means the output voltage is interrupted briefly (clock pulse). The maximum duration of the interruption can be set in the F-DO parameter *Test duration*. The required duration of test pulses is determined by the capacitances in the connected load, which affect the line diagnostics.

For safe disconnection of MOVIFIT® FC or MOVIFIT® MC with a maximum of 3 MOVIMOT®, a test duration of 1 ms must be used.

A capacitance of 1 µF may not be exceeded with connected loads at the F-DO00 and F-DO01 outputs (only applies to setting the maximum test duration of 5000 µs).

Line diagnostics can be deactivated via parameters. Only short circuit and overload protection is active in that case. Crossfaults will not be detected.

It is therefore not recommended to operate the devices without line diagnostics.



▲ WARNING

When line diagnostics is deactivated, the S12 safety option **cannot** detect a short circuit between a sourcing output (F-DO._P) and the +24 V supply voltage or between an M switching output (F-DO._M) and the reference potential.

Severe or fatal injuries.

- Install the wiring in such a way that a short circuit is impossible
 - between a sourcing output (F-DO._P) and the +24 V supply voltage
 - or between an sinking output (F-DO._M) and the reference potential

The outputs F-DO00 and F-DO01 are equipped with an optional open-circuit monitoring function. This function checks whether the connected actuator is consuming a minimum current. If the actuator current is below the minimum value, the S12 safety option detects this as an open circuit.

An wire break detection cannot be activated for the F-DO_STO output.

Only activate open-circuit monitoring when you are sure that the current consumption of the actuator is always above the minimum current (see chapter "Technical data of S12 safety option" / "Safety-related outputs").

Actuator (2-channel, sourcing / sinking output)

S12 safety option

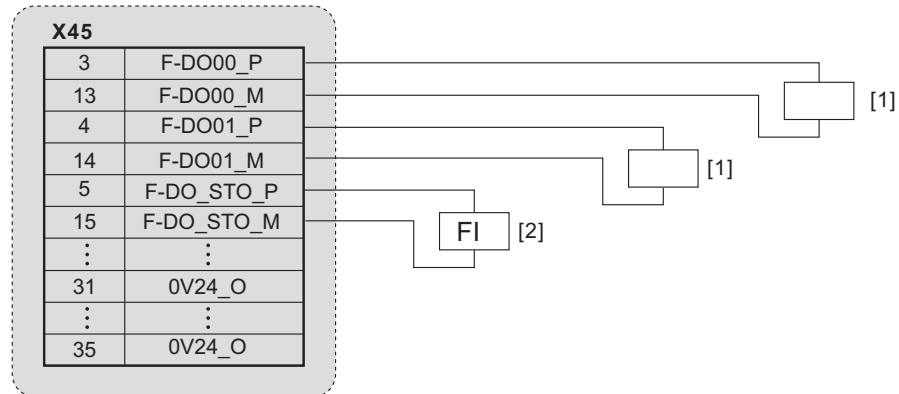

8411782283

[1] Actuators

[2] STO = Safe torque off of the inverter

Connect the actuator between F-DO._P and F-DO._M. The actuator can still be switched off in case of a crossfault in one of the connection lines, as the S12 safety option disconnects the sourcing and the sinking output terminal.

The input of the actuator must be floating and without any connection to a reference potential. Inside the S12 safety option, there is a switching element between F-DO._M and the reference potential. With a non-floating actuator, this switching element would be bridged. The redundancy of the sourcing and sinking output would no longer be given.

The sourcing / sinking output connection variant is therefore suitable for applications up to SIL 3 according to IEC 61508 and Performance Level e according to EN ISO 13849-1.

Fault detection using line diagnostics

The S12 safety option detects the following faults in the external wiring when the output is switched on or off:

- Short circuit between the sourcing output and the +24 V supply voltage
- Short circuit between the sinking output and the 0V24_O reference potential
- Short circuit between the sinking output and the +24 V supply voltage

The S12 safety option can also detect the following faults when the output is activated:

- Short circuit between different sourcing outputs
- Short circuit between different sinking outputs
- Short circuit between sourcing output and sinking output
- Short circuit between the sourcing output and the 0V24_O reference potential
- Overload at any output
- Wire break (with F-DO., if activated)

INFORMATION



In case of a short circuit, a high short-circuit current can occur for a short time. Depending on the 24 V supply voltage used, this can cause a voltage drop that affects the operation of MOVIFIT® and/or individual assemblies.

If the voltage supply is not stable enough, it may result in a reset and a restart of the S12.

- Make sure the voltage supply does not collapse in case of output short circuits.

Actuator (1-channel, sourcing)

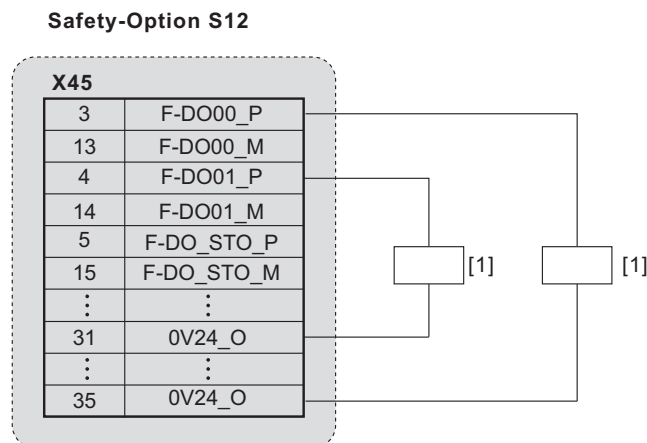

8411764235

[1] Actuators

Connect the actuator between F-DO._P and the 0V24_O reference potential.

The actuator input does not have to be floating.

The sourcing output connection variant is therefore suitable for applications up to SIL 3 according to IEC 61508 and Performance Level d according to EN ISO 13849-1.

The S12 safety option detects the following faults in the external wiring when the output is switched on or off:

- Short circuit between the sourcing output and the +24 V supply voltage

The S12 safety option can also detect the following faults when the output is activated:

- Short circuit between different sourcing outputs
- Short circuit between the sourcing output and the 0V24_O reference potential
- Overload at any output
- Wire break (F-DO., if activated)

**▲ WARNING**

In case of a short circuit between the sourcing output and a 24 V supply voltage, the S12 safety option can no longer switch off the actuator and go to a safe state.

The line diagnostics function can detect the fault, however, the S12 safety option cannot go to a safe state as there is no redundant switch-off channel in this connection variant.

- Route the cables in such a way that a short circuit between the sourcing output and a +24 V supply voltage is not possible.
- Or make sure that an additional, redundant switch-off channel is available for the actuator (e.g. by using a second sourcing output).

INFORMATION

SEW-EURODRIVE recommends to use the sourcing/sinking output or 2 parallel, sourcing outputs, if possible.

For safety-related outputs, refer also to chapter "Technical data".

INFORMATION

In case of a short circuit, a high short-circuit current can occur for a short time. Depending on the 24 V supply voltage used, this can cause a voltage drop that affects the operation of MOVIFIT® and/or individual assemblies.

If the voltage supply is not stable enough, it may result in a reset and a restart of the S12.

- Make sure the supply does not collapse in case of output short circuits.

6.4 Built-in encoder EI7C FS

6.4.1 Properties

The EI7C FS built-in encoder is a safety-related incremental encoder with 24 signal periods per revolution.

The S12 safety option can detect a minimum speed of 60 min^{-1} in connection with an EI7C FS built-in encoder.

The EI7C FS built-in encoder is used to monitor the speed or direction of rotation of the motor for the safety functions SS1a, SLS, and SDI.

The S12 safety option evaluates the signal of the EI7C FS built-in encoder.

The S12 safety option and the EI7C FS built-in encoder monitor the encoder signal. The S12 safety option detects interruptions and crossfaults in the encoder line. If an error occurs, the S12 safety option activates the STO safety function in MOVIFIT®, and the torque is safely switched off.

Only use the EI7C FS built-in encoder in connection with the S12 safety option.

6.4.2 Installation

Use a shielded cable to connect the EI7C FS built-in encoder to the matching encoder inputs of MOVIFIT®.

The EI7C FS built-in encoder is connected to the terminal box of the motor with an 8-pole M12 plug connector. Pins 7 and 8 of the plug connector must **not** be connected.

The encoder cable must meet the following requirements:

- Max. length of the encoder cable: 30 m
- Minimum core cross section: 0.25 mm^2
- The encoder cable must be shielded. The shield must be connected over a large surface area at both ends.
- The cores of the encoder cable must be twisted in pairs.

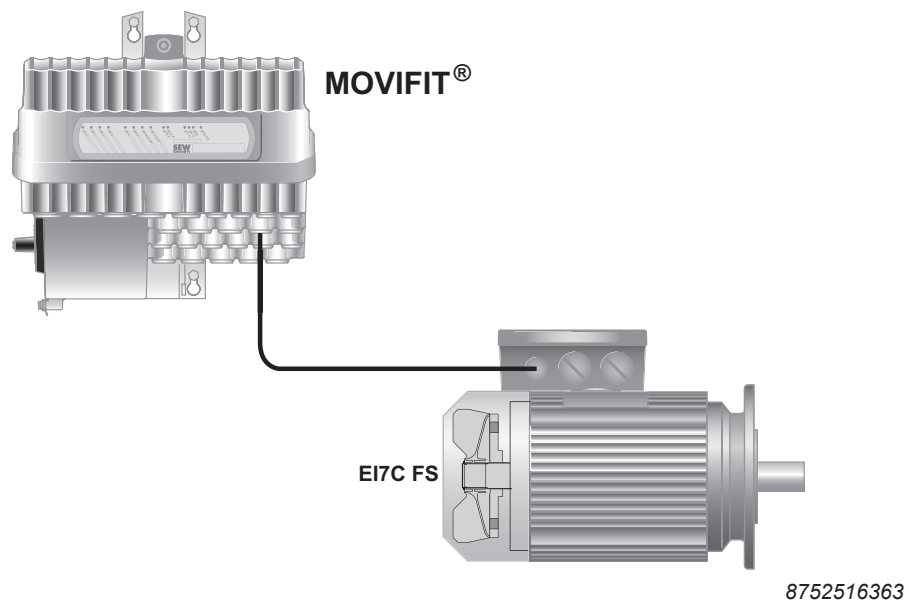

**▲ WARNING**

Incorrect wiring can disable the encoder functions and encoder monitoring.

Severe or fatal injuries.

- Only connect the encoder with the S12 safety option as illustrated above.
- The encoder signals may only be connected to the designated terminals of a MOVIFIT® device. It is not permitted to connect other devices or assemblies.
- Only use the designated cables and plug connectors to connect the encoder (M12, 8-pole and M12, 4-pole). Other plug connectors or terminals are not permitted.

**INFORMATION**

- When connecting an EI7C FS built-in encoder to the MOVIFIT® device, the encoder cable must not carry a TF signal.
- When using an EI7C FS built-in encoder together with application modules, the digital inputs DI04 – DI07 at the X25 terminal of the application module may not be used at all, or as encoder inputs only.
- The S12 safety option can detect a minimum speed of 60 min⁻¹ in connection with an EI7C FS built-in encoder.

Standard ABOX encoder connection

X25: I/O terminals



▲ WARNING

Danger due to incorrect connection of EI7C FS built-in encoder. If the track signals of the encoder are swapped by mistake during wiring, the encoder can report an incorrect direction of rotation. This might lead to the motor turning in the wrong direction.

Severe or fatal injuries.

- Make sure that the EI7C FS built-in encoder is wired correctly according to the following terminal assignment:

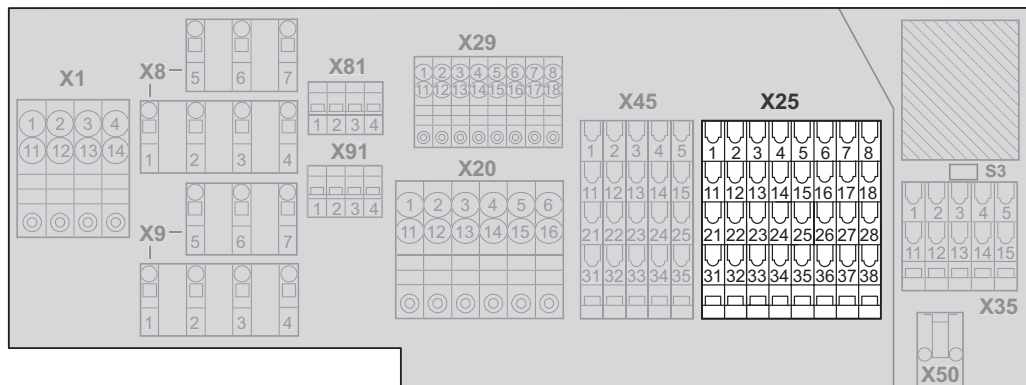

812537739

I/O terminal for digital inputs/outputs (connection of sensors + actuators)						
No.	"Technology" function level with					
	<ul style="list-style-type: none"> • PROFIBUS • PROFINET 					
	Function level "Classic" with PROFINET			Function level "Classic" with PROFIBUS		
	Name	Function	Name	Function		
X25	3	DI04	FS encoder track A connection	DI02	FS encoder track A connection	
	4	DI06	FS encoder track \bar{A} connection	DI03	FS encoder track \bar{A} connection	
	13	DI05	FS encoder track B connection	B	FS encoder track B connection	
	14	DI07	FS encoder track \bar{B} connection	B/	FS encoder track \bar{B} connection	
	23	VO24-II	+24 V sensor supply group II (DI04 – DI07) from +24V_C	+24 V sensor supply group II (DI02 – DI03) from +24V_C		
	24	VO24-II	+24 V sensor supply group II (DI04 – DI07) from +24V_C	+24 V sensor supply group II (DI02 – DI03) from +24V_C		
	33	0V24_C	0V24 reference potential for sensors			
	34	0V24_C	0V24 reference potential for sensors			

22865268/EN – 06/2016

Wiring diagram

The following wiring diagram shows the basic encoder connection with the available cables.

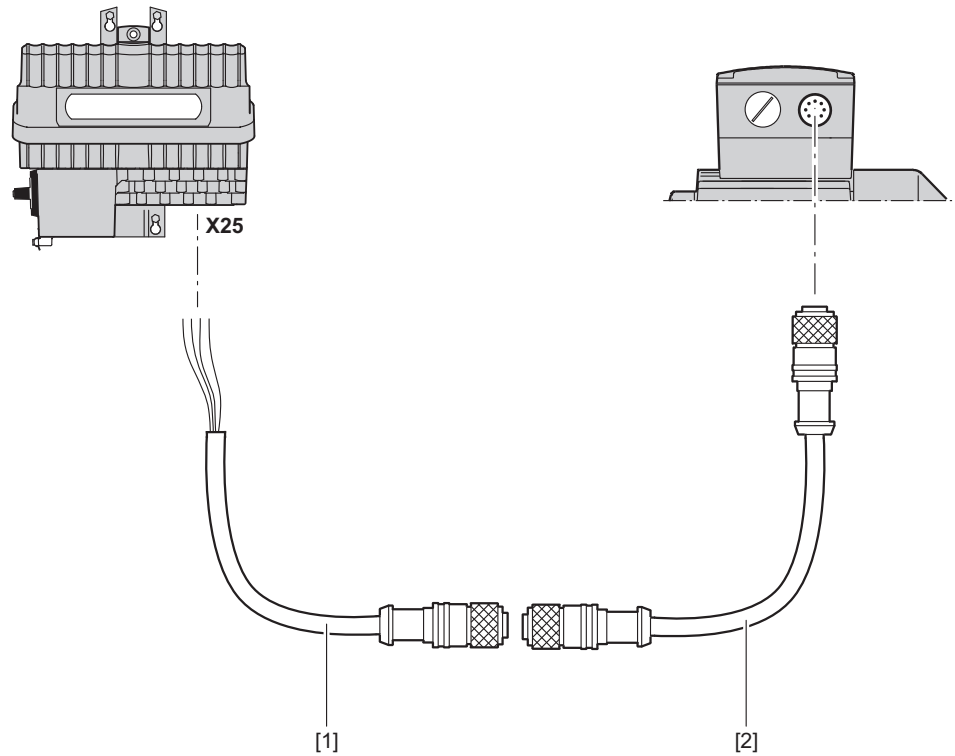



12524754187

- [1] Encoder cables
- Part number: 18156754
- [2] Extension cable, 8-pole
- Part number: 18158013 (cable carrier installation possible)

Connection cable

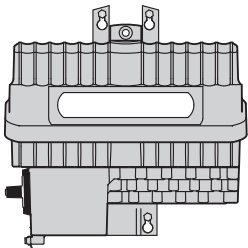
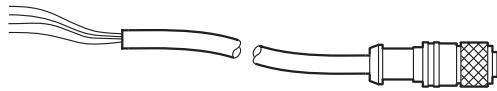
The following table shows the cables available for this connection:

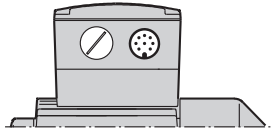
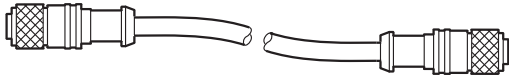
MOVIFIT®	Connection cable	Length/Installation type	Drive
Standard ABOX: 	Encoder cables Part number: 18156754 	Variable 	Motor with cable glands and AVRE plug connector 
	Socket M12, 8-pole, female, A-coded	Extension cable, 8-pole Part number: 18158013 (cable carrier installation possible) 	

Pin assignment M12 socket

The following table shows the pin assignment of the M12 socket of the encoder cable (part number: 18.156.754).

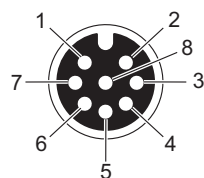

M12, 8-pole, female, A-coded			
Pin	Terminal	Color coding	Function
1	X25/23	Gray	24 V supply
2	X25/33	Pink	0V24 reference potential
3	X25/3	Brown	FS encoder track A
4	X25/4	White	FS encoder track \bar{A}
5	X25/13	Yellow	FS encoder track B
6	X25/14	Green	FS encoder track \bar{B}

22865268/EN – 06/2016

Hybrid ABOX encoder connection

X23, X24: Digital inputs/outputs

The number and assignment of digital inputs/outputs depends on

- the function level (technology or classic)
- and the fieldbus interface of the MOVIFIT® device.

X23, X24 assignment

The following table shows information about these connections:

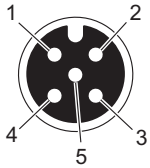
Function			
Digital inputs/outputs of the hybrid ABOX			
Connection type			
M12, 5-pole, female, A-coded			
Wiring diagram			
			
MOVIFIT® variant	Assignment		
PROFINET: • Technology • Classic PROFIBUS: • Technology	No.	X23 (FS encoder connection)	X24 (FS encoder connection)
	1	VO24-II	VO24-II
	2	FS encoder track B DI05	FS encoder track \bar{B} DI07
	3	0V24_C	0V24_C
	4	FS encoder track A DI04	FS encoder track \bar{A} DI06
5	n.c.	n.c.	
PROFIBUS: • Classic	No.	X23	X24
	1	VO24-II	VO24-II
	2	FS encoder track B -	FS encoder track \bar{B} -
	3	0V24_C	0V24_C
	4	FS encoder track A DI02	FS encoder track \bar{A} DI03
5	n.c.	n.c.	

Wiring diagram

The following wiring diagram shows the basic encoder connection with the available cables.

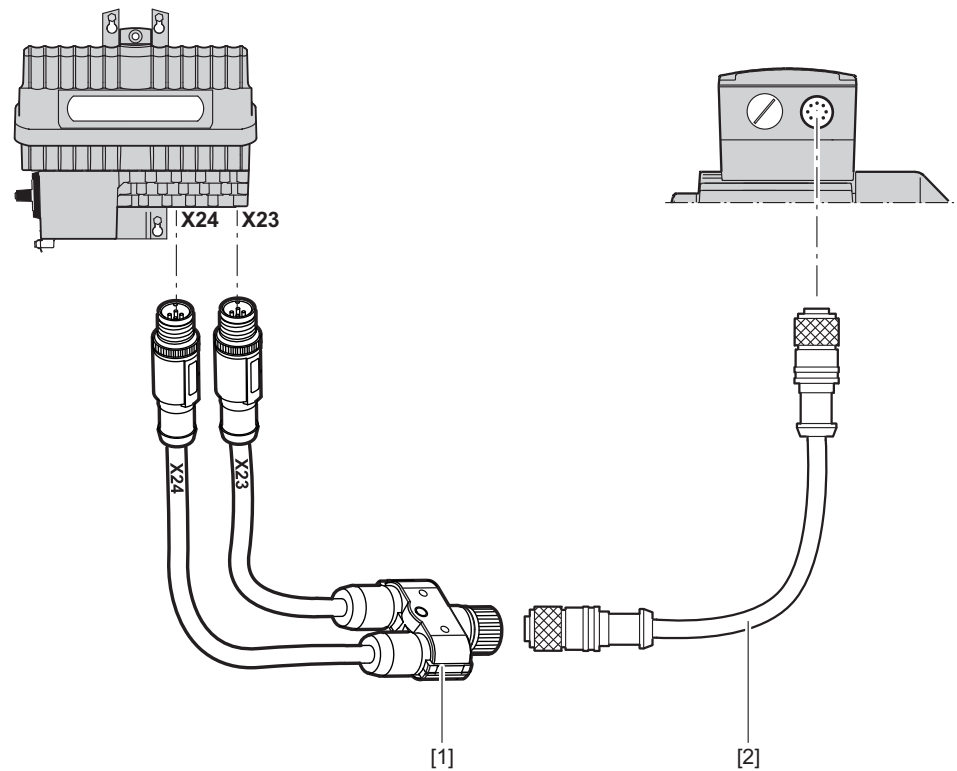

12524758283







- [1] Y adapter M12-Y AVRE-MOVIFIT V01
Part number: 19093632
- [2] Extension cable, 8-pole
- Part number: 18148670 (cable carrier installation not possible)
 - Part number: 18158013 (cable carrier installation possible)

6 Electrical installation

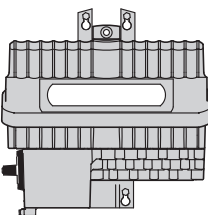
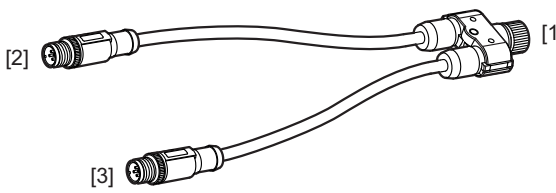
Built-in encoder EI7C FS

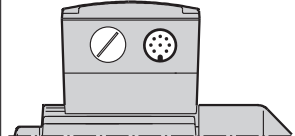
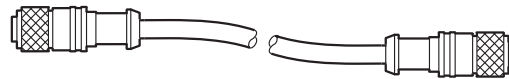
Connection cable

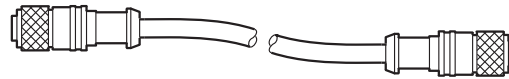
The following table shows the cables available for this connection.

MOVIFIT®	Connection cable	Length/ Installation type	Drive
	Y adapter M12-Y AVRE-MOVIFIT V01 Part number: 19093632 	0.3 m 	Motor with cable glands and AVRE plug connector 
	[1] Socket M12, 8-pole, female, A-coded [2] Connector (Connection to X23 hybrid ABOX) M12, 4-pole, male, standard-coded [3] Connector (Connection to X24 hybrid ABOX) M12, 4-pole, male, standard-coded	Extension cable, 8-pole Part number: 18148670 (cable carrier installation not possible) 	Variable 
	Part number: 18158013 (cable carrier installation possible) 		

INFORMATION



Both connection cables (Y adapter and extension cable) must be used at all times!

22865268/EN – 06/2016

Pin assignment M12 socket

The following table shows the pin assignment of the M12 socket (item [1]) of the Y adapter cable (part number: 19.093.632).

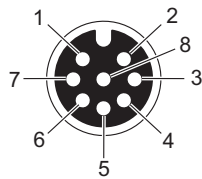

M12, 8-pole, female, A-coded	
Pin	Function
1	+24 V supply voltage
2	0V24 reference potential
3	Encoder input track A
4	Encoder input track \bar{A}
5	Encoder input track B
6	Encoder input track \bar{B}
7, 8	Not connected

Pin assignment M12 connector (connection to X23 of hybrid ABOX)

The following table shows the pin assignment of the M12 connector (item [2]) of the Y adapter cable (part number: 19093632).

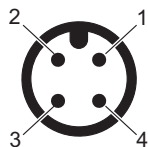

M12, 4-pole, male, standard-coded	
Pin	Function
1	+24 V supply voltage
2	Encoder input track B
3	0V24 reference potential
4	Encoder input track A

Pin assignment M12 connector (connection to X24 of hybrid ABOX)

The following table shows the pin assignment of the M12 connector (item [3]) of the Y adapter cable (part number: 19.093.632).

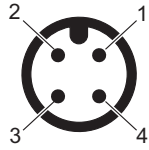

M12, 4-pole, male, standard-coded	
Pin	Function
1	N.C.
2	Encoder input track \bar{B}
3	N.C.
4	Encoder input track \bar{A}

7 Safety functions of the S12 safety option

This chapter describes the safety functions of the S12 safety option. Information about standards and directives for the safety functions is given in chapter "Drive safety functions" (→ 21).

The figures and parameter abbreviations (e.g. t_1) are those from the parameterization tool "Assist S12".

7.1 STO – Safe Torque Off

7.1.1 Description of the function

The following figure shows the sequence of events:

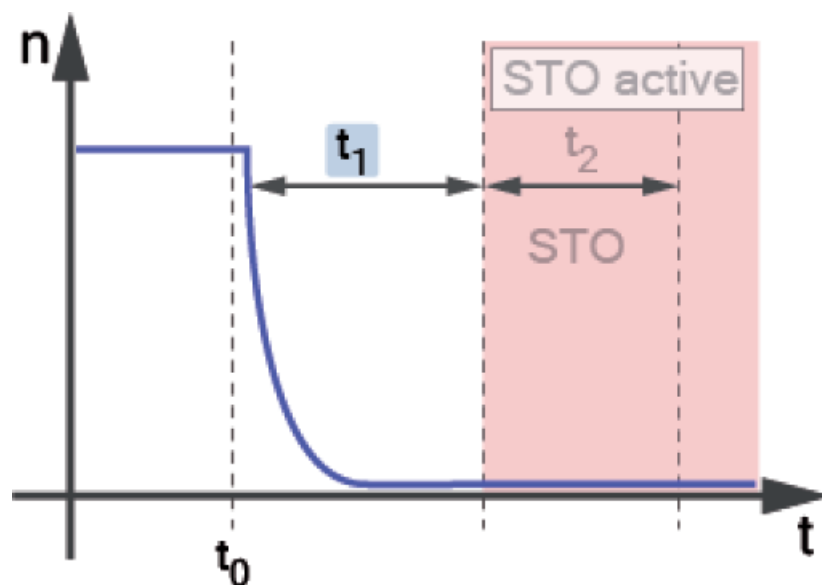

9007208000810635

The STO function in connection with the assigned safety-related output and the power section is used to safely deactivate the torque of the drive (see chapter "Safe disconnection of MOVIFIT®" (→ 32)).

With the S12A safety option, you can also assign the safety-related outputs F-DO00 and F-DO01 to the STO function.

Function "STO selected" (only in S12A safety option variant)

When the STO function is activated, all safety-related outputs assigned to the function "STO selected" are switched off immediately. With the *STO delay* (t_1) parameter, the switching off of the safety-related output F-DO_STO is delayed. This allows the shut-down of the actuators before the motor torque is switched off.

If STO is activated due to a fault, e.g. limit speed exceeded (SLS), the "STO delay" (t_1) is not used.

The MOVIFIT® FC version offers a diagnostic function that monitors the communication connection to the power section.

When the S12 safety option detects a communication with the integrated FC power section even though the F-DO_STO output is switched off, an error message is issued.

This function allows the system to detect a "bridged/faulty" STO connection with the power section.

INFORMATION



The communication monitoring function is not safety-related and is only available with integrated power section of the FC variant. If the power section is wired incorrectly or in case of crossfaults in the output, a error response to establish a safe state (STO) cannot be ensured.

7.1.2 Activation

The safety function "Safe Torque Off (STO)" can be activated at the time t_0 by the following control signal sources:

- F-DI (see function assignment)
- Process data (PROFIsafe)

7.1.3 Status

The status of the STO safety function is transmitted via the status information in the "STO Active" process data.

7.1.4 Parameter

The following table lists the parameters of the safety function.

Parameter	Description
<i>STO delay (t1)</i>	The <i>STO delay (t1)</i> is the time delay between tripping the STO safety function and switching off F-DO_STO, and other F-DO outputs parameterized to STO, if applicable. F-DO outputs can also be assigned to the tripping of the safety functions STO (at time t_0).
<i>STO status display delay (t2)</i>	The <i>STO status display delay (t2)</i> is the time by which the STO active signal in the PROFIsafe process data is delayed after the F-DO_STO output is switched off.
<i>Permitted coasting time (t3)</i>	The coasting duration is the time between tripping the STO safety function and the drive going below the minimum speed (see chapter "Coasting duration measurement" (→ 84)).

7.2 SS1(c) – Safe Stop 1

7.2.1 Description of the function

The following figure shows the sequence of events:

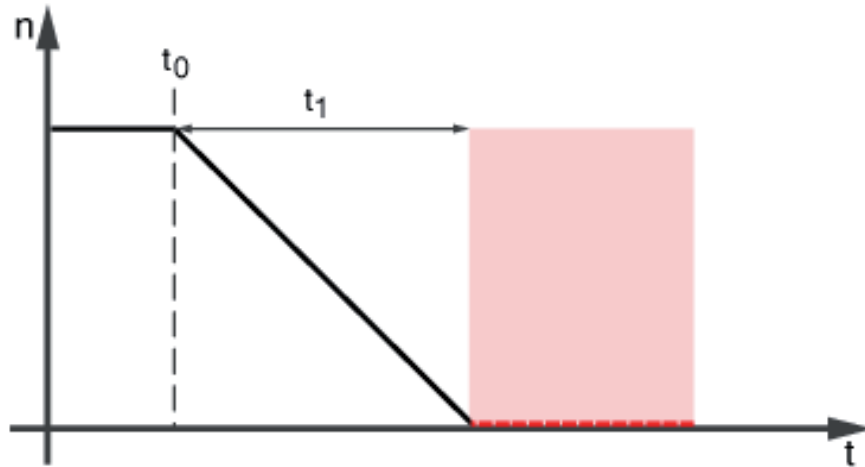

8746073611

When the SS1(c) safety function is tripped, the parameterized SS1(c) delay (t_1) is started, and a stop command is transmitted to the inverter at the same time. After the delay time has elapsed, the STO function is tripped, see chapter "STO – Safe Torque Off" (→ 67).

When SS1(c) is deactivated, the STO function is deactivated as well (as long as it is not activated by other control signal sources).

If the SS1 function is deactivated during the SS1(c) delay, the stop command to the inverter is revoked.

7.2.2 Activation

The safety function SS1(c) can be activated at the time t_0 by the following control signal sources:

- F-DI (see function assignment)
- Process data (PROFIsafe)

7.2.3 Status

The status of the SS1(c) safety function is transmitted via the status information in the "SS1 Active" process data.

7.2.4 Parameter

The following table lists the parameters of the safety function.

Parameter	Description
Function	Function enable.
SS1c delay (t_1)	The SS1(c) delay (t_1) is the time between the tripping of the safety function and the activation of the STO function.

7 Safety functions of the S12 safety option

SS1(a) – Safe Stop 1

7.3 SS1(a) – Safe Stop 1

7.3.1 Description of the function

The following figure shows the sequence of events:

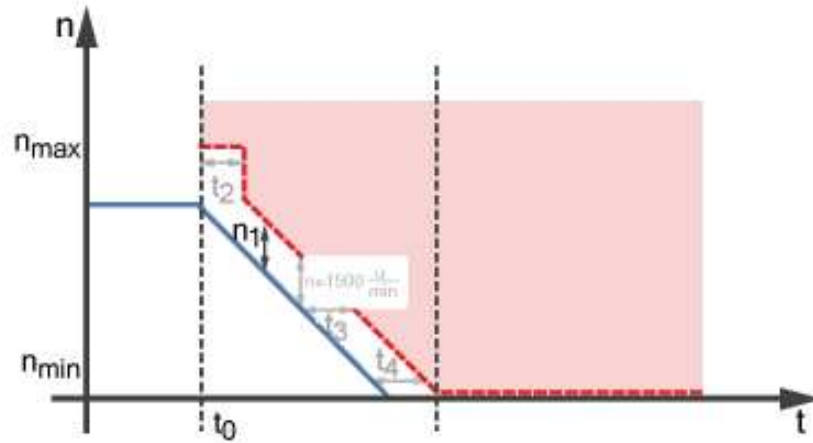

8746077579

The safety function described below is only available with connected encoder and parameterizable encoder evaluation.

The SS1(a) variant of the SS1 function is used to monitor the deceleration of the drive to a standstill. The inverter receives a stop command and the parameterized limit of the speed deceleration ramp *SS1a ramp time* (t_3) and initiates the speed deceleration ramp.

For the duration of the *SS1a ramp monitoring delay* (t_2), the speed is only monitored with respect to the parameterized *maximum motor speed* n_{max} .

After that, the function starts monitoring whether the ramp-shaped speed limit curve is exceeded.

The STO function is activated when the speed limit curve reaches "0", or when the currently monitored speed limit values are exceeded.

If the SS1 function is deactivated before the STO function is activated, the stop command to the inverter is revoked.

When SS1(a) is deactivated, the STO function is deactivated as well (as long as it is not activated by other control signal sources).

The speed is monitored symmetrically in both directions of rotation.

7.3.2 Activation

The SS1(a) safety function can be activated by the following control signal sources:

- F-DI (function assignment)
- Process data (PROFIsafe)

7.3.3 Status

The status of the SS1(a) safety function is transmitted via the status information in the "SS1 Active" process data.

22865268/EN – 06/2016

7.3.4 Parameter

The following table lists the parameters of the safety function.

Parameter	Description
<i>Function</i>	Function enable.
<i>SS1a ramp monitoring delay (t2)</i>	Time delay until the speed deceleration ramp is monitored.
<i>SS1a ramp time (t3)</i>	Ramp time of the speed limit curve and limit of the speed deceleration ramp for the inverter
<i>SS1a STO function selection delay (t4)</i>	Delay time from when the drive goes below the minimum speed until the STO function is tripped
<i>SS1a Distance to ramp (n1)</i>	Speed tolerance for calculating the speed limit curve
<i>Maximum motor speed (n_{max})</i>	Monitored maximum speed from the activation of the safety function until the start of monitoring of the speed deceleration ramp (speed limit curve). Applicable for SS1(a) function and all SLS function blocks together.
<i>Minimum motor speed (n_{min})</i>	Lower limit for speed monitoring.

7.4 SLS – Safely Limited Speed

7.4.1 Description of the function

The following figure shows the sequence of events.

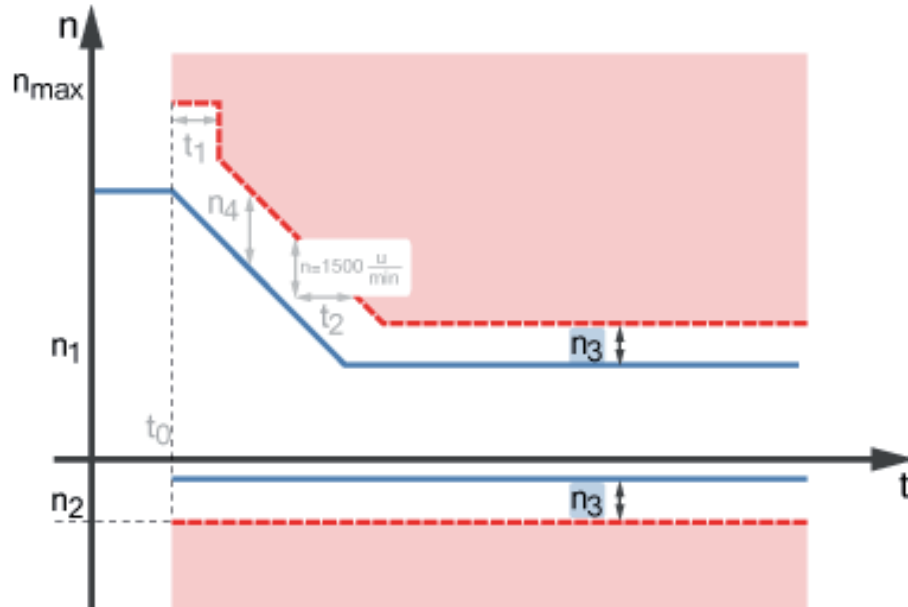

8746081547

The safety function described below is only available with connected encoder and parameterizable encoder evaluation.

The SLS function monitors the motor speed for violation of a limit value. This is implemented with different speed limit values for the positive and negative direction of rotation.

Before the safety function becomes active when tripped, the speed can be reduced along a monitored deceleration ramp if the speed is higher than the set speed setpoint limit for the inverter at the time when the function is tripped.

When the function is tripped, the setpoint limits for both directions of rotation and the parameterized limit of the speed deceleration ramp *SLS ramp time* are transferred to the inverter, so that the inverter can begin with the speed deceleration ramp.

The setpoint limits for the inverter result from the SLS speed limit values *Limit speed, positive (n1)* and *Limit speed, negative (n2)* minus the SLS speed tolerance *Difference to limit speed (n3)*.

For the duration of the *SLS ramp monitoring delay (t1)*, the speed is only monitored with respect to the parameterized *maximum motor speed n_max*.

After that, the function starts monitoring whether the ramp-shaped speed limit curve is exceeded.

In the opposite direction, the parameterized SLS speed limit is monitored during the entire time. The monitored speed reduction phase ends when the ramp-shaped speed limit curve reaches the parameterized speed limit value. Then, the SLS safety function becomes active.

For operation of systems with speed overshoots, a speed filter is integrated in the SLS function. If the activated SLS function detects an overshoot over the speed limit values, this will be tolerated within the parameterized rotation angle range *SLS speed filter* without initiating an error response.

The parameterized error response is only triggered when the integral of the overspeed exceeds the parameterized *speed filter* limit value.

This means speed overshoots can be tolerated without the motor speed exceeding the parameterized speed limit values for a longer time.

If an error causes the exceedance of the current speed limit value during the ramp phase or of the parameterized integral limit value, the parameterized error response (SS1 or STO) is triggered.

There are 4 equal-priority function blocks available for the SLS function. They control and monitor the parameterized speeds independently of each other. When more than 1 SLS function block is activated, the lowest setpoint limitation is relevant.

De-select the SLS function to cancel speed limitation.

7.4.2 Activation

The individual function blocks of the SLS safety function can be activated by the following control signal sources:

- F-DI (function assignment)
- Process data (PROFIsafe)

7.4.3 Status

The status of each function block of the safety function is transmitted via a separate status information block in the "SLS Active" process data.

7.4.4 Error response

The error response to overspeed can be parameterized:

- STO (the time *STO delay* ($t1$) is not effective)
- SS1(a) or SS1(c), depending on the parameter settings for the SS1 function

7.4.5 Parameter

The following table lists the parameters of the safety function:

Parameters that are not specific to SLS:

Parameter	Description
<i>SLS ramp monitoring delay (t1)</i>	Time delay until the speed deceleration ramp is monitored.
<i>SLS ramp time (t2)</i>	Ramp time for the monitored speed limit curve in the S12 safety option and for the limit of the speed deceleration ramp in the inverter
<i>SLS difference to ramp (n4)</i>	Speed tolerance to calculate the speed limit curve during the speed deceleration ramp.
<i>SLS speed filter</i>	Limit value for the integral of the tolerated exceedance of the speed limit values (= tolerated angle of rotation). This means speed overshoots can be tolerated without the motor speed exceeding the parameterized speed limit values for a longer time.
<i>SLS error response to overspeed</i>	Error response of SLS function to over-speed.
<i>Maximum motor speed</i>	Monitored maximum speed from the activation of the safety function until the start of monitoring of the speed deceleration ramp (speed limit curve). Also applies to SS1a function.
<i>Minimum motor speed</i>	Lower limit for speed monitoring. Also applies to SS1a function.

Parameters that are specific to SLS function blocks:

Parameter	Description
<i>SLS function</i>	Function enable.
<i>SLS positive limit speed (n1)</i>	Speed limit value in the positive direction of rotation, which is monitored by the S12 safety option when the respective SLS function block is activated.
<i>SLS negative limit speed (n2)</i>	Speed limit value in the negative direction of rotation, which is monitored by the S12 safety option when the respective SLS function block is activated. This value is not signed.
<i>SLS difference to limit speed (n3)</i>	Speed tolerance (corresponds with the difference between monitored speed limit value and the setpoint limit for the inverter). This parameter applies to both directions of rotation.

7.4.6 Speed filter

The following figure shows the speed filter.

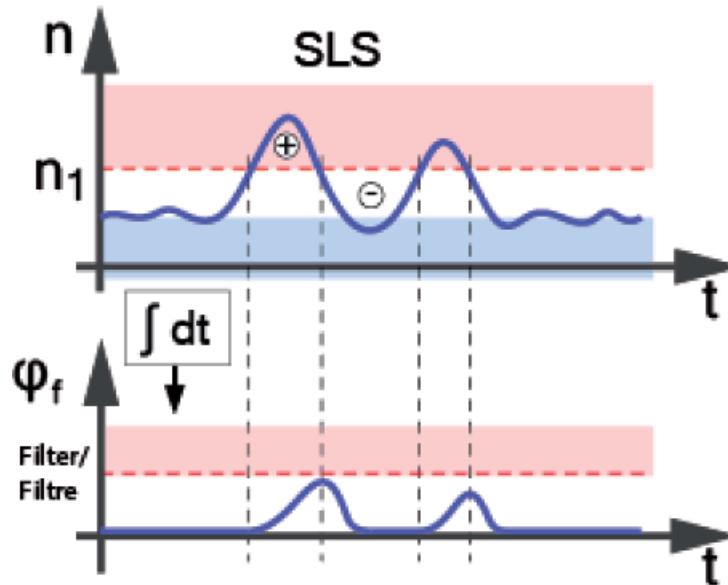

9007208001389579

The value of the speed filter is the tolerable limit value for a brief exceedance of the parameterized SLS limit speed. Physically, the filter limit value corresponds to a tolerated angle of rotation (integral filter of the angle of rotation).

Determination of speed filter value:

1. In the "SLS general" screen of the "Assist S12" parameterization tool, enter the maximum value of the *speed filter* and accept the parameter settings (1000°).
2. Determine the maximum overshoots in productive operation.
3. Read out the determined maximum value from the diagnostics screen "Safety function (maximum overshoot)" of the "Assist S12" parameterization tool. Add a suitable tolerance to the value and compare this value with the value from the risk assessment. Transfer the determined parameter *SLS speed filter* and accept the parameter settings.

7.5 SDI – Safe Direction

7.5.1 Description of the function

The following figure shows the sequence of events.

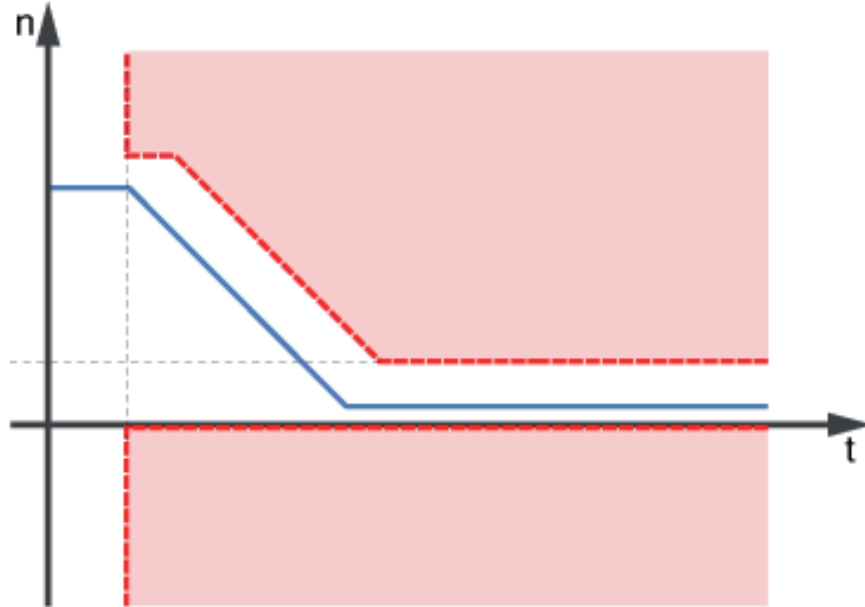

8746085515

The safety function described below is only available with connected encoder and parameterizable encoder evaluation.

The "SDI function" monitors the direction of rotation of the motor. It is part of each SLS function block and can only be selected via this function block.

The SDI function is parameterized in the respective parameter blocks of the SLS function. The SDI function is activated by selecting the corresponding SLS function.

Within a SLS function block, you can block either the positive or negative direction of rotation by enabling the SDI function. When the drive moves into the blocked direction, the STO function is activated after an adjustable tolerance value *SDI tolerance* and a system-related error detection time. A system-related tolerance value of 7° must be added to the adjustable tolerance value *SDI tolerance*.

INFORMATION



The SDI function is for monitoring purposes only. The blocked direction of rotation must be restricted in addition by the SLS function. To do so, parameterize the SLS limit speed of the blocked direction of rotation to the tolerance value (SLS parameter *Difference to limit speed (n3)*).

7.5.2 Activation

The SDI safety function can be activated by the following control signal sources:

- F-DI (function assignment)
- Process data (PROFIsafe)

In each case, it can only be activated by selecting the corresponding SLS function.

7.5.3 Status

The status of the SDI safety function is transmitted via the status information in the process data. When the SDI safety function detects an incorrect rotation into the prohibited direction, the "ASF error" bit is set to "0".

7.5.4 Error response

Error response for movement into the blocked direction of rotation:

- STO (the time *STO delay (t1)* is not effective)

7.5.5 Parameter

The following table lists the parameters of the safety function:

Parameter	Description
<i>SDI function</i>	Function enable (blocking a direction of rotation)
<i>SDI tolerance</i>	Tolerated movement into the blocked direction of rotation. Applies to all SLS/SDI function blocks.

7.6 Safety-related inputs

7.6.1 Description of the function

The S12A variant has 4 inputs. The S12B variant has 8 safety-related inputs. The inputs can be connected and parameterized in 1-channel, 2-channel equivalent, or 2-channel non-equivalent mode.

You can connect the following sensors to the safety-related F-DI inputs:

- Electromechanical sensors (switches, buttons, emergency off, etc.)
- Sensors with contact-based outputs
- Sensors with electronic output (initiators, etc.)
- Sensors with OSSD output

The possible connection variants depend on the type of sensor. The range of connection variants might be limited depending on the sensor type.

The following chapters describe the evaluation of terminal signals for the permitted connection types. For detailed information about electrical connections, refer to chapter "S12 safety option" (→ 40).

7.6.2 Connection type

Connection type: 1-channel

Each input terminal is assigned one-to-one to a process value.

Input terminal Dlx	Process value Dlx	Discrepancy monitoring
0	0	–
1	1	–

(x = 0, 1, 2, ..., 7)

Connection type: 2-channel equivalent

The two input terminals Dlx and Dlx+1 of the input pair are connected to equivalent-switching sensors/switches. They are assigned to the shared process value Dlx. The Dlx+1 process value is set to "0" in 2-channel connection mode.

Input terminal Dlx	Input terminal Dlx+1	Process value Dlx	Process value Dlx+1	Discrepancy monitoring
0	0	0	(0)	OK
0	1	0	(0)	Discrepancy detected
1	0	0	(0)	Discrepancy detected
1	1	1	(0)	OK

(x = 0, 2, 4, 6)

Connection type: 2-channel non-equivalent

The two input terminals Dlx and Dlx+1 of the input pair are connected to non-equivalent switching sensors/switches. They are assigned to the shared process value Dlx. The Dlx+1 process value is set to "0" in 2-channel connection mode.

Input terminal Dlx+1 (inverted processing)	Process value Dlx	Process value Dlx+1	Discrepancy monitoring
0	0	(0)	Discrepancy detected
1	0	(0)	OK
0	1	(0)	OK
1	0	(0)	Discrepancy detected

(x = 0, 2, 4, 6)

The F-DI process value determined in this way is both sent via fieldbus (F-Dlx bit) and used for function assignment. If an error occurs in input processing (e.g. crossfault, no stable signal within the filtering time, etc.), the process value of the corresponding F-DI input pair goes to a safe state. This case is not shown in the tables above.

Discrepancy time

Discrepancy monitoring is active for the 2-channel connection types. It checks for invalid switching states within one F-DI input pair (equivalent switching type: different levels, non-equivalent switching type: same levels), which can be caused by a defect. If a prohibited switching state exists longer than the set discrepancy time, an error is detected.

Depending on the type of the connected switch(es), there can be a significant time delay between the switching times of the two inputs when the switch is actuated. The discrepancy time should be set longer than the maximally expected time delay.

Input filter

The input signal goes through a parameterizable filter to eliminate contact bouncing and interference. Bounces that are shorter than the set filter time are removed from the signal.

The filter has an additional time monitoring function. If a fault lasts longer than the set filter time, an error can be detected.

Crossfault monitoring

To detect faults in the external wiring, the "Crossfault monitoring" diagnostic function can be use. It can be activated for each input via the parameter *Crossfault monitoring*.

Crossfaults are detected by the S12 safety option switching off the sensor supplies F-SS0 and F-SS1 briefly with a time delay (pulsed voltage supply). A logical "0" level is now expected at the corresponding F-DI terminals. The prerequisite for this is that the connected switches are supplied by the corresponding sensor supplies, and that pulsed sensor supply is activated.

Pulsed sensor supply of F-SS0 and F-SS1 can be activated or deactivated together via the parameter *F-DI pulsed sensor supply*. With pulsed sensor supply deactivated, +24 V is permanently present at the F-SS0 and F-SS1 terminals.

Switch test

The switch test function is used to check a connected switch when a discrepancy error occurs. Before the error can be acknowledged, the switch must be actuated, so that both signals of the F-DI input pair are in the required state for the switch test.

Switch test state	Input terminal DIx	Input terminal DIx +1
Equivalent connection type	0	0
Non-equivalent connection type	0	1

With this, the system can detect faulty switches, which would lead to a discrepancy only in the actuated state (e.g. in case of emergency off switches).

7.6.3 Status

The status of the safety-related inputs is transmitted via the status information in the process data.

7.6.4 Error response

The error response to the exceedance of the input filter time or the discrepancy time:

- Process value of the F-DI input pair is set to 0.

The effects depend on the setting of the parameter "IO error effects" within "General".

7.6.5 Parameter

The following table lists the parameters of the safety function:

Parameter	Description
<i>Connection type</i>	Setting the desired F-DI connection type (1-channel, 2-channel equivalent or 2-channel non-equivalent).

22865268/EN – 06/2016

Parameter	Description
<i>Input filter time (t1)</i>	Filter time for the input signal.
<i>Discrepancy time (t2)</i>	Maximum permitted time difference between the signal changes of the input signals of a 2-channel connection.
<i>F-DI pulsed sensor supply</i>	Pulsed voltage supply active: F-SS0 and F-SS1 are connected to a pulsed voltage supply. Pulsed voltage supply not active: F-SS0 and F-SS1 are connected to a continuous 24 V supply.
<i>F-DI crossfault monitoring</i>	Activation of crossfault monitoring for the corresponding F-DI.
<i>F-DI switch test</i>	Switch test active: Errors can only be acknowledged after a signal change to the disabled state.

7.7 Safety-related outputs

7.7.1 Description of the function

The safety-related output F-DO_STO is fixedly assigned to the STO safety function of the S12 safety option. It is used to activate the safe torque off function of the integrated FC inverter or of the connected MOVIMOT® drives.

The S12A variant has 2 additional, safety-related, freely usable 24 V switching outputs F-DO00 and F-DO01, which can be controlled via fieldbus and the "STO active" and "STO selected" safety functions of the S12 safety option. The two outputs can be used as 2-pole sourcing/sinking outputs or 1-pole sourcing outputs.

Each output has a sourcing output terminal F-DO._P and a sinking output terminal F-DO._M.

For a sourcing/sinking output connection, the load is connected between F-DO._P and F-DO._M, so that each output terminal can interrupt the current flow through the load.

For a sourcing output connection, the load is connected between F-DO._P and ground.

All outputs offer the following testing and monitoring functions:

- Short circuit and overload protection is always active. The output current of each output is monitored. In case of overload, the output is switched off. The sum of the output currents is also monitored.
- Line diagnostics can detect short circuits and crossfaults in external wiring. When the output is active, test pulses are used to test the functioning and wiring of the output. You can deactivate this with the *Line diagnostics* parameter, if necessary.
- Wire-break monitoring can detect an interrupted output circuit if the output current falls below the minimum load. You can activate this monitoring function with parameter *Wire break monitoring*.

7.7.2 Error response

The error response during tripping of the diagnostic functions line diagnostics and wire break monitoring:

- Process value of the output is set to 0.

The effects depend on the setting of the parameter "IO error effects" within "General".

7.7.3 Status

The status of the safety-related outputs is transmitted via the status information in the process data.

7.7.4 Parameter

The following table lists the parameters of the safety function.

Parameter	Description
<i>Connection type</i>	Setting the chosen connection type (2-pole sourcing/sinking or 1-pole sourcing).
<i>Line diagnostics</i>	Activation of line diagnostics for the output.
<i>Test duration</i>	Maximum switch-off time for line diagnostics of the safety-related output F-DO.
<i>Wire break monitoring</i>	Activation of wire break monitoring (can only be activated with F-DO).

7.8 Function assignment

The following figure shows an example for a function assignment in the parametrization tool "Assist S12".

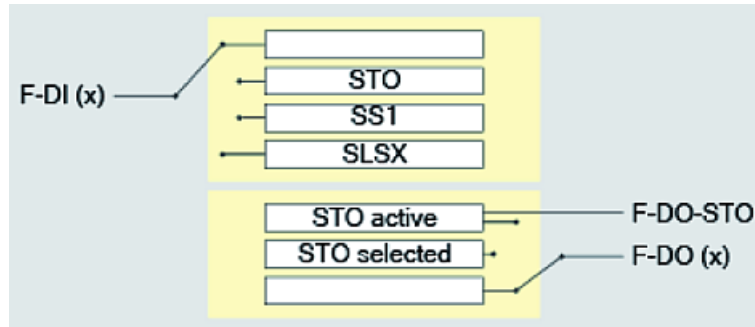

12069950475

Safety functions control

All safety functions can be controlled via the digital inputs of the S12 safety option. For this purpose, the process values of the digital inputs are assigned to the safety functions control. It is also possible to assign several inputs to one safety function.

In fieldbus operation, simultaneous control via F-DI and bus process data is possible. The safety function becomes active when at least one of the control signal sources requests its activation.

The same applies to the assignment of multiple F-DI to one safety function.

Different safety functions can be activated in parallel and at the same time.

Output control

In addition to control via process data, the freely usable outputs F-DO00 and F-DO01 can be controlled by the functions "STO active" and "STO selected". Each control signal can switch off the output.

When the outputs are assigned to the STO function, the input for safe torque off of other frequency inverters can be connected there.

Interlocking logic

For applications in which a deactivation of safety functions without user intervention must be prevented (e.g. automatic restart), the interlocking logic can be used. The F-DI process value for the activation of the safety function remains in a safe state until it is acknowledged.

Interlocking can be acknowledged:

- Via a separate F-DI that was parameterized to the function "Acknowledge interlocking F-DI and error"
- Or via fieldbus (safe process output data).

Interlocking is always acknowledged with a rising edge (0/1).

The interlocking logic can be activated by setting the relevant parameters.

When the S12 safety option is switched on, the process values of F-DI parameterized to "interlocking" are initially interlocked in a safe state (irrespective of the input signal).

7.8.1 Parameter

The following table shows the parameters:

Parameter	Description
<i>F-DI interlock</i>	Activation of the F-DI interlock function.

22865268/EN – 06/2016

Parameter	Description
<i>F-DI function</i>	Assignment of F-DI to safety functions or to acknowledging/interlocking function.
<i>F-DO function</i>	Only with S12A safety option: Assignment of "STO active"/"STO selected" safety functions to outputs F-DO00 and F-DO01.

7.9 Test mode

7.9.1 Description of the function

To validate the safety functions, it is necessary to test the associated monitoring functions and their limits. With the test mode the speed control functions of the S12 safety option to the inverter can be deactivated for the safety functions.

The safety functions themselves including speed monitoring remain active in test mode. When test mode is activated, the inverter can be controlled via its standard control sources (e.g. fieldbus, manual operation, application module) so that it violates the speed limits of the selected safety functions, which will allow you to assess the corresponding error response behavior.

7.9.2 Activation

- "Assist S12" parameterization tool
- Process data (PROFIsafe) via "SF test" bit

The test mode has a time limit. It is cancelled automatically after 5 minutes.

If you still require the test mode after 5 minutes, you must re-activate it. Test mode is also cancelled automatically if the STO function is activated intentionally or as an error response, e.g. with the SS1(a) or SLS/SDI function.

7.9.3 Status

The activation state of the test mode is shown by the "SF test active" status message in the process input data (PROFIsafe) and by the green/yellow-flashing F-State LED in the device.

The test mode offers no status message indicating the correct operation of the tested safety function. To assess the correct operation of the drive, you can use the error messages of the SLS and SS1 function.

7 Safety functions of the S12 safety option

Coasting time measurement

7.10 Coasting time measurement

7.10.1 Definition

The coasting time is the period from activating the STO function to when the drive falls below the minimum speed.

The coasting time depends on several factors, especially load torque, moment of inertia of the load, and the braking torque of the brake. If the coasting time is relevant or if it must be checked regularly, the parameterization tool "Assist S12" supports this if an EI7C FS built-in encoder is used.

The application coasting time changes over time due to different influencing factors such as e.g. wear. The function "coasting time measurement" measures the application coasting time cyclically. This way, maintenance and service work can be initiated at an early stage.

7.10.2 Description of the function

The following figure shows the sequence of events:

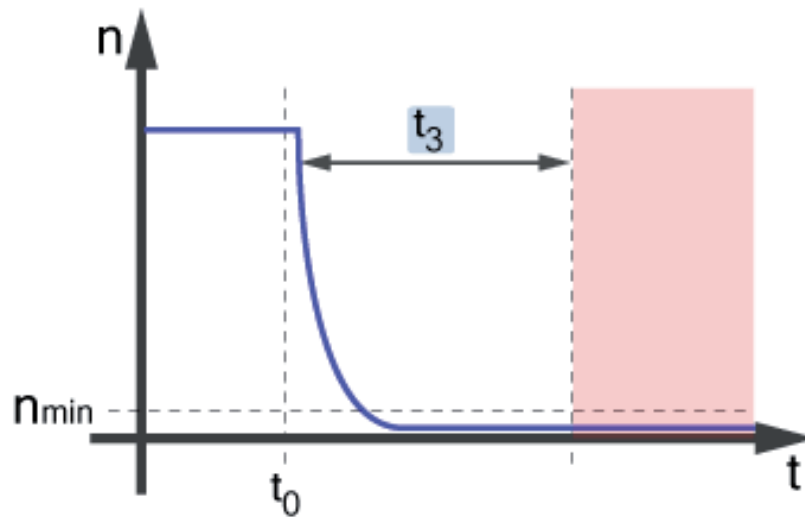

8746089483

To check the coasting time, the parameterization tool "Assist S12" provides the function "coasting time measurement".

The coasting time measurement function measures the time between the activation of the STO function and the undercut of the minimum speed, using the safety-related EI7C FS built-in encoder and speed measurement.

It compares the measured time with the parameterized limit value *Permitted coasting time* (t_3) and issues an error message if the limit value is exceeded.

7.10.3 Determining the reference value

Proceed as follows to determine the reference value for the parameter *Permitted coasting time (t3)*:

1. Enter the maximum value (65535 ms) into the "STO" screen on the parameterization tool "Assist S12" for the parameter *Permitted coasting time (t3)*.
2. Transfer the parameterization to the S12 safety option.
3. Execute the STO function at maximum speed and then control the display values "Application coasting with selecting STO" in "Safety functions".

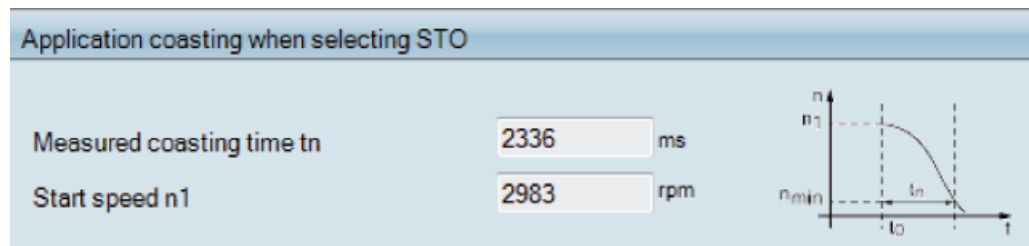

12078453259

4. Add an additional value suitable for your application to the display value *Measured coasting time (tn)* and enter the result in the field for the parameter *Permitted coasting time (t3)*.
5. Transfer the parameterization to the S12 safety option.

Now, the function "coasting time measurement" can be used as described in chapter "Activation".

INFORMATION



If the limit value for the permitted coasting time is specified by a risk assessment, this value must be entered as limit value.

7.10.4 Activation

The coasting time measurement starts when the STO function is activated if a *Permitted coasting time* limit value \neq "0" is parameterized. When the parameterized limit value is exceeded, an error message is only issued if the test mode for the safety function was activated before the STO function. (The test mode is automatically deactivated again when STO is activated).

INFORMATION



The result of the coasting time measurement is valid only if the STO function decelerates the drive to a standstill.

7.10.5 Parameter

The following table lists the parameter of the diagnostic function.

Parameter	Description
<i>Permitted coasting time (t3)</i>	Limit value for the STO coasting time. An error message is issued when this limit is exceeded.

**INFORMATION**

To assess the correct operation of the drive, you can use the error messages of the S12 safety option. The measured coasting time and the corresponding current speed when the STO function is activated are shown in the "Assist S12" parameterization tool.

The coasting time measurement function is for diagnostic purposes only.

8 Startup

8.1 General startup instructions

INFORMATION



- The startup procedure of the standard functions of MOVIFIT® FC or MOVIFIT® MC is described in the respective "MOVIFIT®..." operating instructions and in the corresponding "MOVIFIT® Function Level Classic..." or "MOVIFIT® Function Level Technology..." fieldbus manual.
- The following chapters describes the additional startup procedure of the S12 safety option and its safety functions.
- Note the prerequisites for installation and operation of MOVITOOLS® MotionStudio.
- With MOVITOOLS® MotionStudio versions before V6.00, note that the device signature of the S12 safety option contains 16 digits.
- When starting up several similar devices with identical S12 parameterization, they can be parameterized via the "Import/Export" function. Note that you have to validate every single device.

8.2 Startup variants 1 – 3

8.2.1 Variant 1: Default parameter setting (without "Assist S12" parameterization tool)

The S12 safety option is delivered with a default parameter set that allows you to use the S12 safety option without changing any parameters. In this operating mode, the following conditions must be taken into account:

- This operating mode is only possible with PROFIsafe fieldbus operation.
- The iPar CRC value is stored as default value in the GSDML file for the S12A safety option. This value is suggested to the user during the configuration process. The S12B safety option is also delivered with a default parameter set.

With the S12B safety option, the iPar CRC value must be entered in the PROFIsafe master.

- The statuses of F-DI. and F-DO. can be processed and controlled via the F-PLC without any further parameter setting steps.
- For this startup variant only the safety function STO is supported.

Perform the following steps for startup:

1. "Startup of the fieldbus and the higher-level F-PLC" (→ 91).
2. Startup of the standard functions.
(For detailed information, refer to chapter "Startup" in the "MOVIFIT® ..." operating instructions.)
3. The default parameterization is validated after a function test during the complete approval of the F-PLC program.

8.2.2 Variant 2: Independent operation (no connection to PROFIsafe)

The S12 safety option can be parameterized and operated without PROFIsafe connection (independent operation).

Consider the following conditions for this operating mode:

- The parameters of the S12 safety option are set with the "Assist S12" parameterization tool.
- The validation of the plant is supported by an acceptance protocol generated in the "Assist S12" parameterization tool.

Perform the following steps for startup:

1. "Parameterization of safety functions" (→ [89](#)) in the "Assist S12" parameterization tool.
2. Startup of the standard functions.
(For detailed information, refer to chapter "Startup" in the "MOVIFIT® ..." operating instructions.)
3. "Verification and validation" (→ [97](#)) supported by the "Assist S12" parameterization tool.

8.2.3 Variant 3: With PROFIsafe connection

The S12 safety option can be parameterized and operated with a PROFIsafe connection (fieldbus connection).

Consider the following conditions for this operating mode:

- The parameters of the S12 safety option are set with the "Assist S12" parameterization tool.
- The validation of the plant is supported by an acceptance protocol generated in the "Assist S12" parameterization tool.

Perform the following steps for startup:

1. "Parameterization of safety functions" (→ [89](#)) in the "Assist S12" parameterization tool.
2. "Startup of the fieldbus and the higher-level F-PLC." (→ [91](#))
3. Startup of the standard functions.
(For detailed information, refer to chapter "Startup" in the "MOVIFIT® FC/MC" operating instructions.)
4. "Verification and validation" (→ [97](#)) supported by the "Assist S12" parameterization tool.

8.3 Setting the safety function parameters

8.3.1 Requirements

You need the parameterization tool "Assist S12" for a successful startup. The parameterization tool "Assist S12" is available in MOVITOOLS® MotionStudio (as of version 5.90, download from www.sew-eurodrive.com).

8.3.2 Parameter setting procedure

This chapter illustrates the parameterization of the safety functions step-by-step.

1. Start MOVITOOLS® MotionStudio

2. Scan network

Scan the network that contains your engineering interface to MOVIFIT® device (RS485, Ethernet, etc.).

3. Start the "Assist S12" parameterization tool.

Start the Assist S12 parameterization tool from the user interface of MOVITOOLS® MotionStudio.

A window appears in that prompts you to enter the serial number of the device.

4. Enter the serial number of the device and establish a connection

Enter the serial number of the MOVIFIT® device which needs to be parameterized and confirm your entry with [OK].

The serial number is on the nameplate of the MOVIFIT® EBOX (SO#XX.XXXXXXXXXX.XXXX.XX)

The serial number ensures that the "Assist S12" parameterization tool connects to the right device.

5. Upload the current parameter settings of the device

After entering the serial number, the current parameter settings of the S12 safety option are uploaded to the "Assist S12" parameterization tool. The uploaded values are shown in the "S12 actual value" column. This is to read out the current configuration; it can also be done during operation.

6. Parameter setting

Set the parameterization according to your safety-related requirements of your application.

To set the parameters of the S12 safety option, call the individual sections in the parameter tree and enter the required values. In the "General parameters" area, the higher-level parameters, such as IO error effects, fieldbus connection, encoder activation, and maximum speed of the motor are set. In the areas "F-DI" and "F-DO", the parameters of the sensors and actuators are set. After that, the parameters of the safety functions are set and assigned to the parameterized inputs/outputs in the "function assignment" area.

The "Assist S12" parameterization tool creates a parameter set from all parameters.

7. Download the parameter set to the device

Click on the [Download] button to download the parameter set to the S12 safety option. The download is password-protected.

Standard password (default): **sew_s12**

After the download, the transferred parameter set is checked for consistency and plausibility. Possible inconsistencies or plausibility errors are shown and can be corrected.

8. Scan network again

The power section is now detected during this new network scan.

9. Configure the complete MOVIFIT® device (without parameter set)

Configure the complete device using MOVITOOLS® MotionStudio.

This way, all not safety-related parameters are saved locally on the device.

10. Saving the safety-related parameters

Restart the parameterization tool "Assist S12". During the start, already created iPar parameter sets are saved in the project directory of the MOVIFIT® device.

INFORMATION

When you configure the complete device in MOVITOOLS® MotionStudio, the safety-related parameters are **not** saved.

The MOVIFIT® device can only be configured when the S12 safety option has enabled the power section.

For a detailed description of steps 4 – 7, refer to chapter "Assist S12" (→  100).

When the parameter set has been transferred to the S12 safety option without any problems, you can start up the standard functions and, if required, connect it to the higher-level safety controller (F-PLC).

8.4 Startup of the fieldbus and the higher-level F-PLC

Note that this startup variant only supports the safety-related fieldbus profile "PROFIsafe".

8.4.1 Requirements

- The higher-level F-PLC must support iPar CRC.
- You need the parameterization tool "Assist S12" for a successful startup. The parameterization tool "Assist S12" is available in MOVITOOLS® MotionStudio (as of version 5.90, download from www.sew-eurodrive.com).
- Additional requirements for using the S12 safety option with PROFIsafe fieldbus connection via PROFIBUS or PROFINET:
 - STEP7, optional "Distributed Safety" package version 5.4 and higher (for controllers from the company Siemens)
 - GSD file (PROFIBUS) or GSDML file (PROFINET, version 2.6 and higher):
Download from www.sew-eurodrive.com

8.4.2 Setting the PROFIsafe address

Once the MOVIFIT® device including S12 safety option is supplied with 24 V voltage, you must enter the PROFIsafe device address (= F destination address) using the MOVITOOLS® MotionStudio engineering software. Addresses 1 to 65534 are permitted.

Make sure that the device settings match the parameterized PROFIsafe address set in the configuration software of the bus master (e.g. Siemens STEP7 HW Config).

- Start the MOVIFIT® gateway configurator in the MOVITOOLS® MotionStudio engineering software.
- Set the PROFIsafe device address (= F destination address) in the MOVIFIT® gateway configurator, or via the parameter tree for devices with function level "Technology".

Refer to the following illustration:

8

Startup

Startup of the fieldbus and the higher-level F-PLC

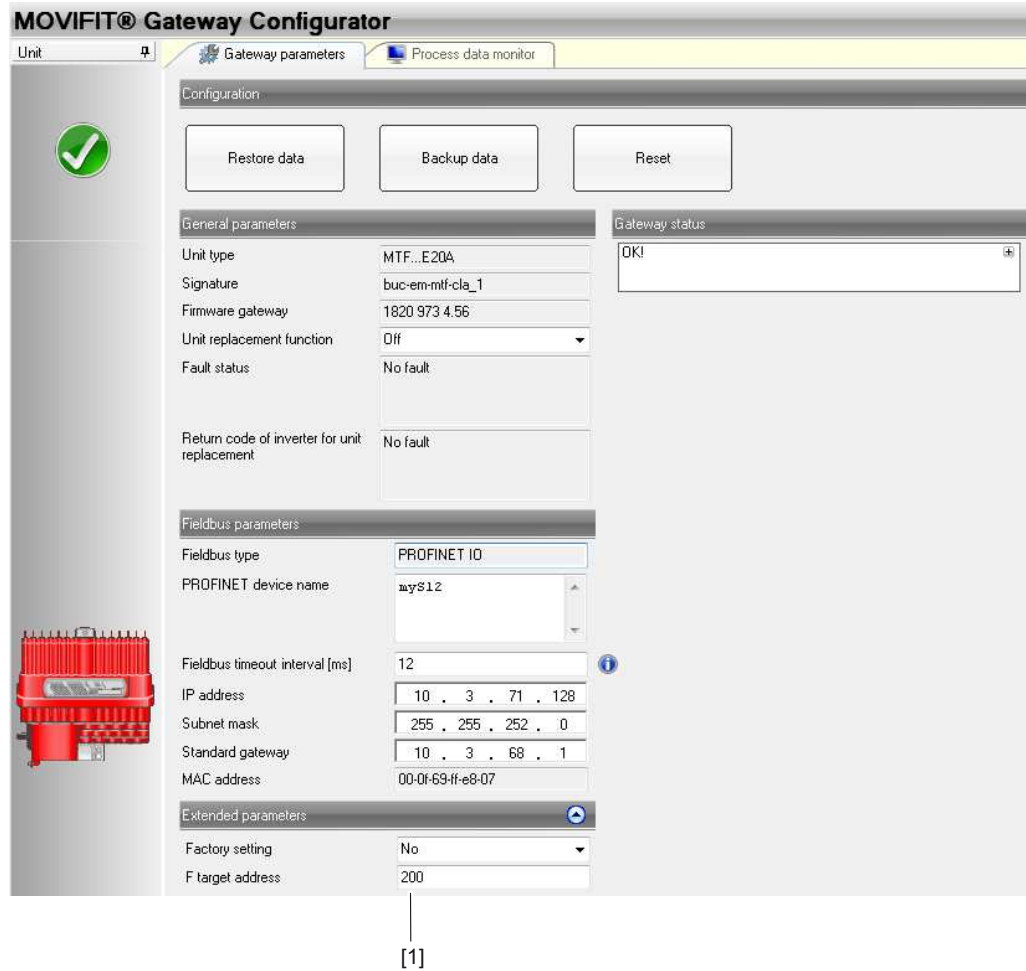

8412992523

[1] Setting the PROFI-safe device address (= F destination address)

8.4.3 Configuring the S12 safety option in STEP 7

To ensure fault-free MOVIFIT® operation using PROFIsafe, you need the optional package "Distributed Safety" as of version V5.4 for the parameterization and configuration under STEP7.

- Make sure that you have installed the current version of the corresponding GSD/ GSDML file.
- When configuring the buses for PROFIBUS DP and PROFINET IO, follow the steps described in the software manual "MOVIFIT® Function Level Classic" or "MOVIFIT® Function Level Technology ...".
- Configure the "F module I/O (5/4 byte)" [1] in slot 1.

To do so, drag-and-drop the module [1] to slot 1 [2] and enter the desired I/O or periphery addresses.

The following figure shows the configuration of a MOVIFIT® with "Classic" function level as PROFINET version.

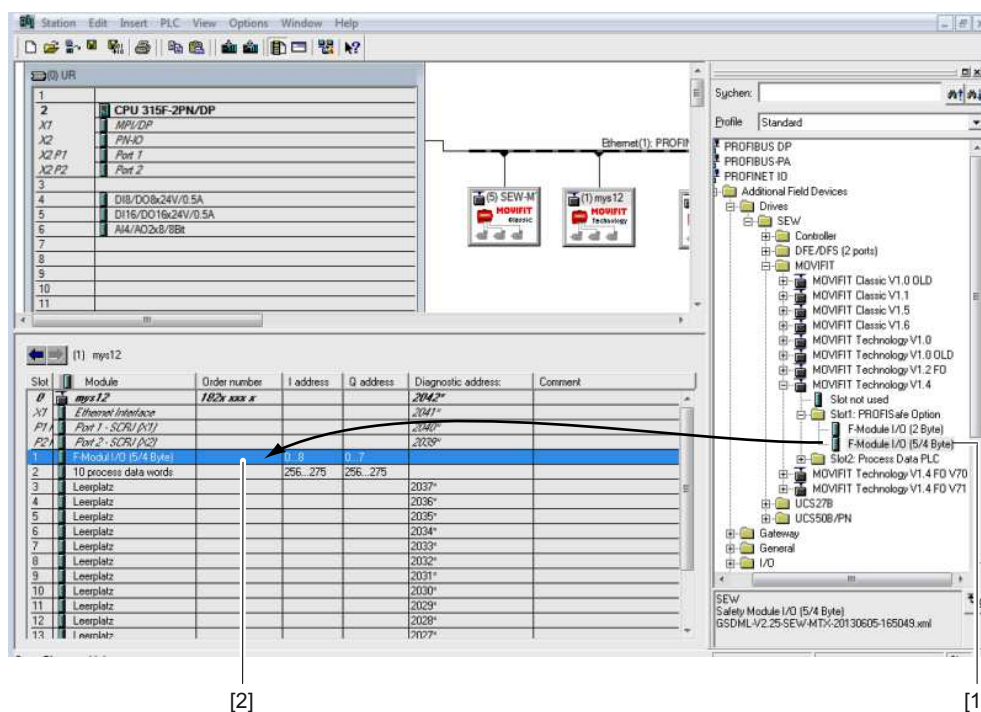

8413287307

- Then, parameterize the S12 safety option via STEP7.

Configuration of S12 safety option

Select the F module at MOVIFIT® slot 1.

Make a right-click to open the context menu, select "Properties", then the "PROFIsafe" or "F parameters" tab. Below is an example of a PROFINET I/O device.

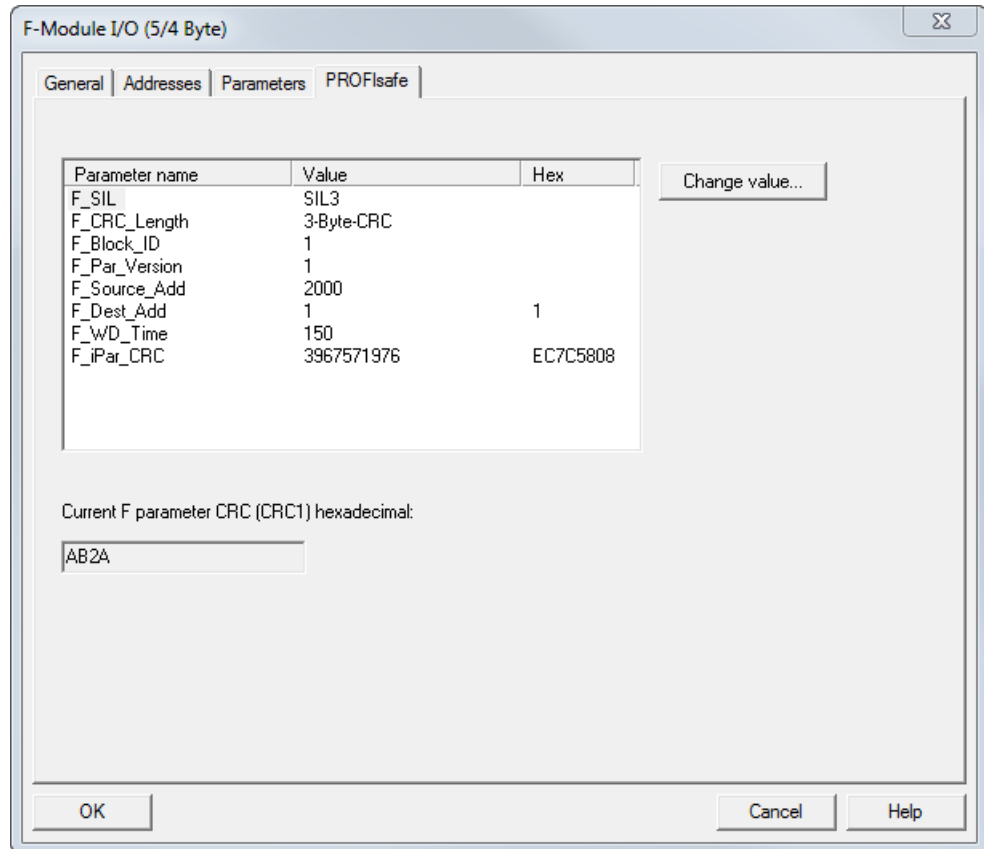

8929749131

When the fieldbus or network systems starts up, the bus master sends the safety-relevant parameters in an F parameter block to the S12 safety option of the MOVIFIT®.

They are checked for plausibility in the option. The S12 safety option only exchanges data with the bus master after a positive confirmation of this F parameter block.

Depending on bus system being used the following safety-related parameters that are available to be transferred to the S12 safety option.

PROFIsafe F parameter	Bus system	
	PROFIBUS DP	PROFINET IO
<i>F_Check_SeqNr</i>	Fixed	Not available
<i>F_SIL</i>	Fixed	Fixed
<i>F_CRC_Length</i>	Fixed	Fixed
<i>F_Block_ID</i>	Fixed	Fixed
<i>F_Par_Version</i>	Fixed	Fixed
<i>F_Source_Add</i>	Fixed	Fixed
<i>F_Dest_Add</i>	Variable	Variable
<i>F_WD_Time</i>	Variable	Variable
<i>F_iPar_CRC</i>	Variable	Variable

F_SIL parameter

This parameter allows F stations to check whether the safety category matches that of the F host. Safety circuits with different safety classes SIL 1 to SIL 3 (SIL = safety integrity level) are available for these safety-relevant cases according to the risk.

The S12 safety option supports the following setting:

- F_SIL = SIL 3

INFORMATION



The safety class SIL 3 only applies to the S12 safety option. The possible safety class for the safety functions depends on the type of the respective MOVIFIT® basic device.

F_CRC_Length parameter

Depending on the length of the F user data (process values) and the PROFIsafe version, the length of the required CRC value varies. This parameter communicates the anticipated length of the CRC2 key in the safety telegram to the F component.

The S12 safety option handles useful data that is less than 12 bytes in length, so that with PROFIsafe V1, a 2 byte CRC is used and with PROFIsafe V2, a 3 byte CRC is used.

The S12 safety option supports the following settings:

- F_CRC_Length = 2 byte CRC (only with PROFIsafe V1 with PROFIBUS)
- F_CRC_Length = 3 byte CRC (only with PROFIsafe V2)

F_Block_ID parameter

The parameter has the value "1" if it exists, and "0" if it doesn't.

The value "1" shows that the data set for *F_iPar_CRC* is expanded by 4 bytes.

NOTICE: The *F_Block_ID* parameter must not be changed.

F_Par_Version parameter

This parameter identifies the PROFIsafe version supported by the S12 safety option. When using a MOVIFIT® device with PROFIBUS, you can choose between PROFIsafe V1 and PROFIsafe V2; with PROFINET, only PROFIsafe V2 is supported.

F_Source_Add parameter

The PROFIsafe addresses are used for a clear identification of source (*F_Source_Add*) and destination (*F_Dest_Add*). The combination of source and destination address must be unique across the network and all nodes. The source address *F_Source_Add* is assigned automatically via STEP7 depending on the configuration of the master.

Values ranging from 1 to 65534 can be entered in parameter *F_Source_Add*.

You cannot directly edit this parameter in STEP7-HW Config.

F_Dest_Add parameter

Enter the PROFIsafe address, previously set for the MOVIFIT® device with MOVITOOLS® MotionStudio, in this parameter.

The *F_Dest_Add* parameter can have values between 1 and 65534.

F_WD_Time parameter

This parameter defines a monitoring time in the failsafe S12 safety option.

A valid safety telegram must arrive from the F-CPU within this monitoring time. Otherwise, the S12 safety option reverts to safe status.

Select a monitoring time of sufficient length so that communication can tolerate telegram delays, but also short enough for your safety application to run without restrictions.

You can enter the *F_WD_Time* parameter in steps of 1 ms, ranging from 1 ms to 10 s for the S12 safety option.

F_iPar_CRC parameter

This parameter represents the CRC value that is calculated from the safety-related device parameters.

The following figure shows the parameter in the "Assist S12" parameterization tool in the window of the "Status display" tool bar.

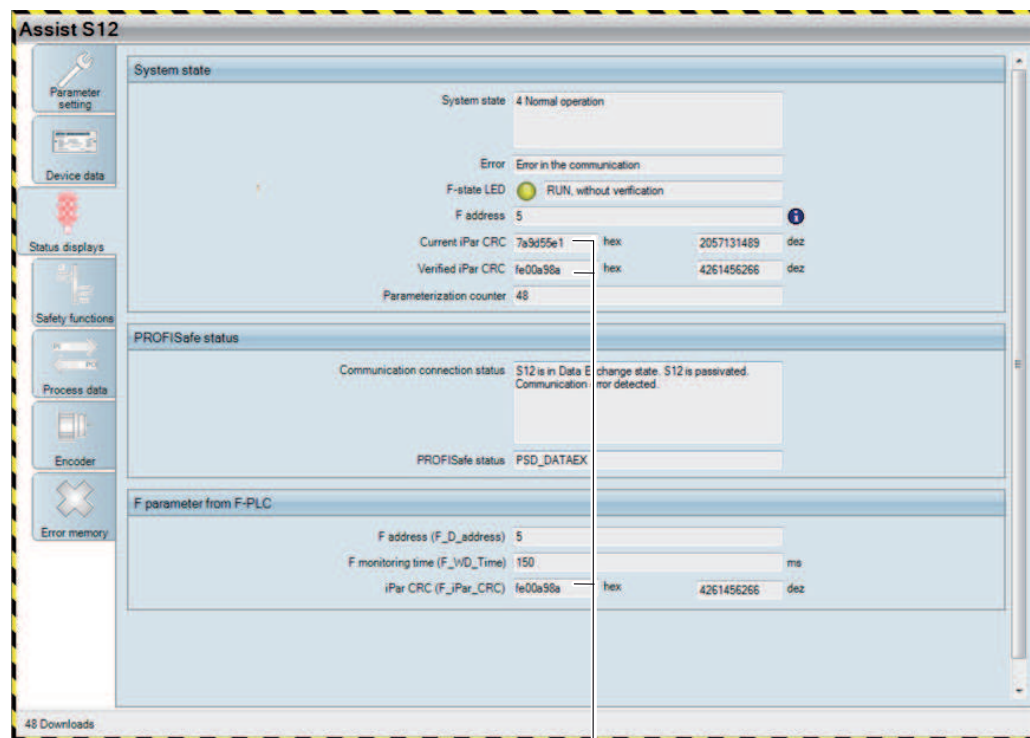

[1]

8419405707

[1] iPar-CRC/F-iPar-CRC

8.5 Verification and validation

8.5.1 Overview

To ensure that the parameterized safety functions work, you have to check the parameters after startup and record this.

- First, check and confirm all parameters in the "Assist S12" parameterization tool (verification).
- Then validate the parameterized safety functions within the framework of a functional test.

To support the validation, the "Assist S12" parameterization tool offers an acceptance protocol function.

For the startup variant "Default programming" note the following:

INFORMATION



Upon delivery the S12 safety option has the status "RUN with approval". The individual areas in the parameter tree need not be verified and the approval protocol is not necessary. The default functions are validated during the overall validation of the application based on the PROFIsafe master.

8.5.2 Verification and acceptance protocol

1. First, check all parameters in the "Assist S12" parameterization tool. To do so, compare the entered values with the displayed actual values.
2. Confirm the check by ticking the "Verified" check box and repeat this process for every page on the "Parameterization" tab.

The verification status is shown in the parameter tree. There you can see which parameter block has already been verified and which still needs to be checked and confirmed. After ticking all "Verified" check boxes, the [Finish] button becomes active in the header.

3. Click the [Finish] button to continue. The "Verification" dialog opens.

8752594059

4. Enter all relevant data. To do so, use the following tabs:
 - Project
 - Validation
 - Contact
 - Application description
5. Click [OK] to transfer the verification status to the device.

The acceptance protocol opens and shows the data you have entered before.

After transferring the verification status, finish the verification depending on the parameterization of the fieldbus connection as follows:

- PROFIsafe: The verification is completed by the bus startup.
- Independent operation: The verification is completed by switch the device off and on again.

INFORMATION



The validation is not completed by transferring the verification status to the S12 safety option.

The user is obliged to carry out a validation of the safety functions by means of functional tests and document them.

8.5.3 Validation

Procedure

Each parameterized safety function must be validated and documented within the framework of a functional test. The "test mode" (→ 83) implemented in the parameterization tool "Assist S12" supports the function tests of speed-related safety functions.

Further, the tool "SEWScope" can be used to record and document speed profiles. For information about using "SEWScope", refer to MOVITOOLS® MotionStudio online help.

Structure of the acceptance protocol

The first chapter of the acceptance protocol lists all relevant system information from the "Verification" windows. The second chapter lists all parameter settings and the corresponding checksum (block CRC).

INFORMATION



- All listed parameters must be validated in the system and confirmed in the acceptance protocol.
- The user must validate all the configured data in the printed acceptance protocol. To do so, the user must check all the set limit values of the activated monitoring functions by performing a functional test.
- The user must check the following in the acceptance protocol:
 - If validation is repeated, the previous protocol can be used for comparison. In this case, the user only has to check the blocks in which parameters have been changed. Note that the CRC values may only deviate in blocks with changed values. In blocks with unchanged parameter value, the CRC values must be the same as in the previous protocol. In the block with changed values, all values have to be checked.
 - The user may not make any subsequent changes in the acceptance protocol.

The user must check the version ID of the parameter set that is printed in the acceptance protocol. The version ID describes the structure of the safety-related parameter set. The version ID changes when the parameter set changes.

The iPar CRC value describes the content of the parameter set. The iPar CRC value changes if one or several parameter is changed.

The following table shows the version ID and the iPar CRC values of the S12 variants.

S12 variant	Version ID	Default iPar CRC	Default iPar CRC (hex)
S12A	3565205509	3967571976	EC7C5808
S12B	2609672025	4219245997	FB7C95AD

9 Assist S12

9.1 Structure of the user interface

The following figure shows the user interface of the "Assist S12" parameterization tool:

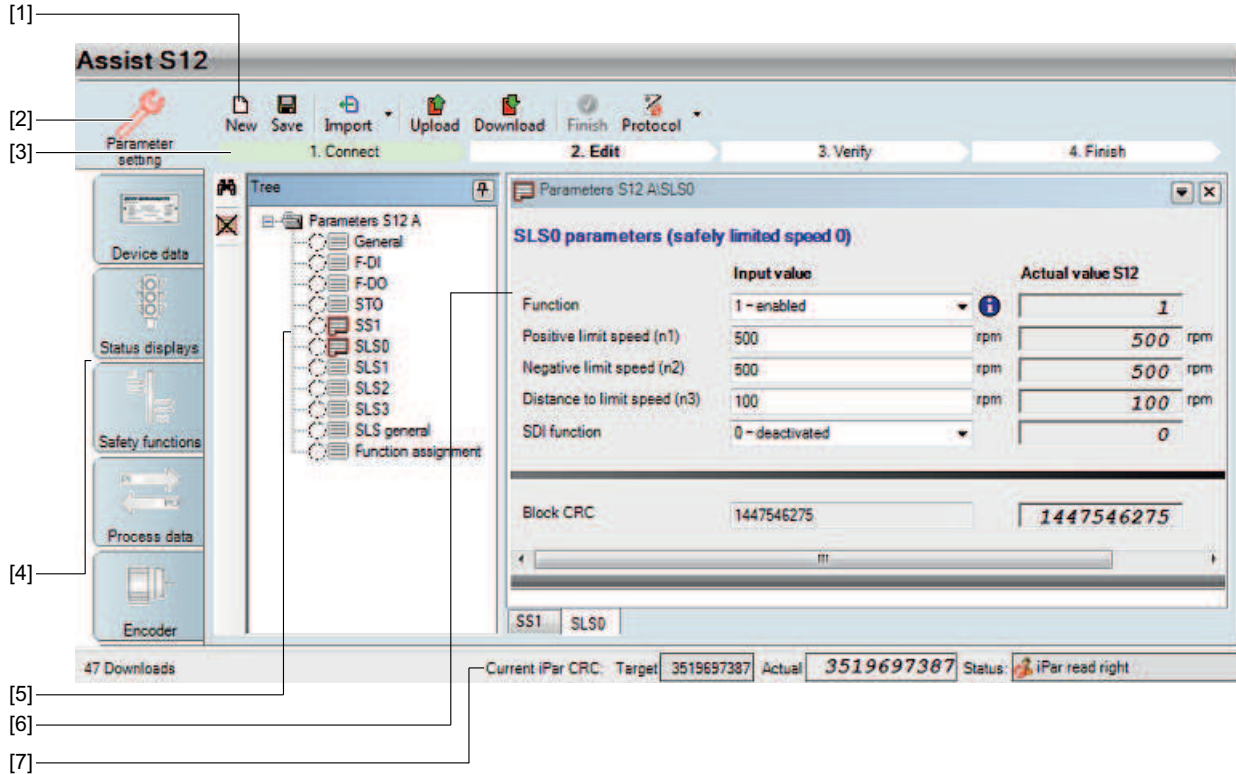

9007207359736715

[1]	Menu bar	The menu bar offers different selection options (depending on the current step in the parameterization procedure). For detailed information, refer to chapter "Menu bar" (→ 101).
[2]	"Parameter setting" function	The "Assist S12" parameterization tool starts the parameter setting function.
[3]	Display of parameterization steps	The parameterization process is shown in 4 steps from left to right: 1. Connect 2. Edit 3. Verify 4. Finish The active step is highlighted and corresponds with the respective selection options in the menu bar.
[4]	Tool bar	Vertically arranged buttons for all tasks. For detailed information, refer to chapter "Tool bar" (→ 102).
[5]	Folder for parameter groups	Double-click a folder to show all the parameters of a group.

[6]	Window of the active parameter group	This window shows drop-down menus and edit boxes to adjust the parameters of a certain group.
[7]	Status bar	The following information is displayed: <ul style="list-style-type: none"> • iPar CRC (setpoint and actual value) • Status (e.g. iPar read access)

The following pages describe the control elements in detail.

9.1.1 Menu bar

The menu bar contains the following buttons:

- **[New]**
Loads the default parameter set to the input value column (corresponding to the connected S12 variant).
- **[Save]**
Saves the current setpoint parameters (input value column) to the PC.
- **[Import/Export/Transfer of actual values → input values]**
 - [Import]
Imports the saved values of a file. The imported values are shown in the "Input value" column.
 - [Export]
Saves the current setpoint parameters ("input value" column) in a selectable file.
 - [Transfer actual values→ input values]
The parameters of the "Actual value S12" column are transferred to the "Input value" column (available as of MOVITools® MotionStudio version 6.20).
- **[Upload]**
Loads the parameters from the S12 safety option to the S12 actual value column.
- **[Download]**
Sends the current setpoint parameters of the input value column to the S12 safety option. The "Upload" is then carried out automatically.
- **[Finish]**
After a download, the user has to compare and verify the input value and S12 actual value columns again. The result of this verification (= the ticked check boxes) is sent to the S12 safety option by clicking the [Finish] button.
- **[Protocol]**
Shows the acceptance protocol that was generated last. The user can also select an acceptance protocol from the drop-down list connected to the [protocol] button.

9.1.2 Parameterization steps

The parameterization steps are shown below the menu bar. The steps are represented by 4 arrows that show the active step in the parameterization process.

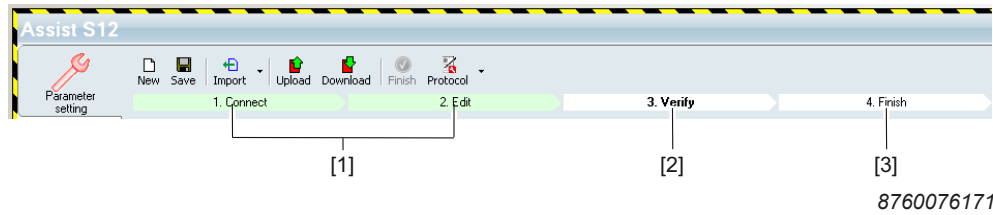

Arrow colors:

- Green arrows [1] show the steps that have already been completed (here: "1. Connect" and "2. Edit").
- The white arrow with the bold print [2] shows the currently active step (in this case "3. verify").
- The other white arrows [3] show the steps that are yet to be completed.

9.1.3 Tool bar

The tool bar contains buttons for the following tasks:



8783091339

- Click on a button to open the window with the display and entry options for the corresponding task.

The following chapter describes the individual tasks in detail.

9.1.4 Parameterization window

The window in the "Parameterization" area is divided into two parts:

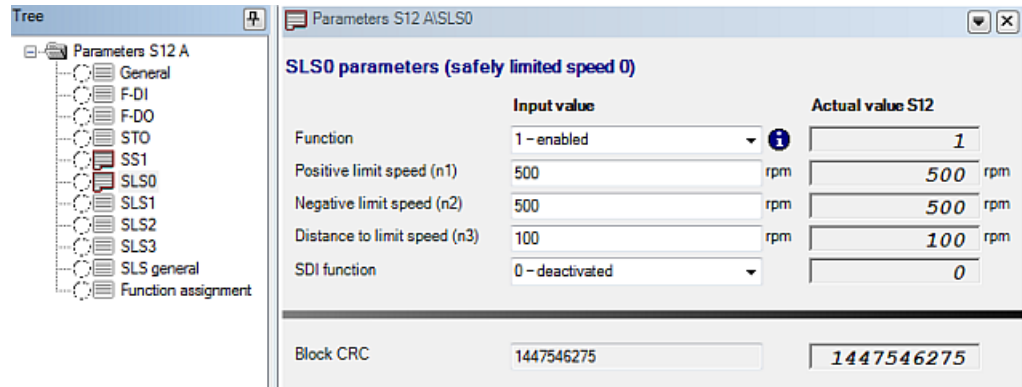

9007208014821515

The left shows the parameter tree, which can be used to navigate between the parameter groups. Double-click on the individual parameter blocks/groups to expand them. The parameters are then shown on the right.

9.1.5 Plausibility error indication

The following figure gives an example of how plausibility errors are shown in the two parameter groups (on the left) "General" and "SLS0":

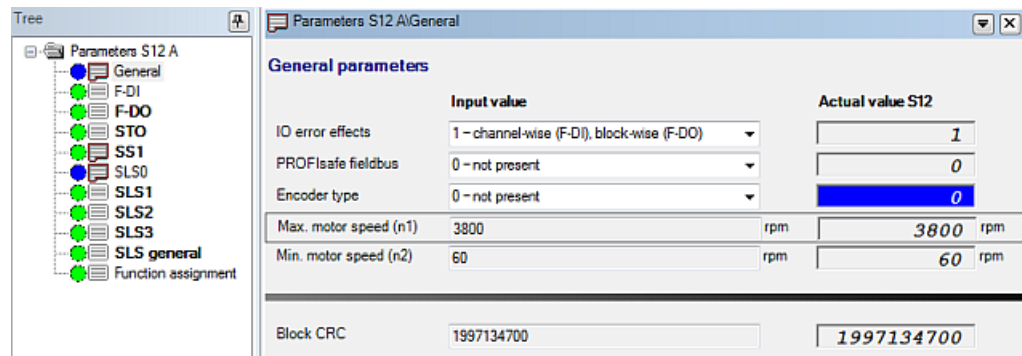

9007208031234315

Plausibility errors are marked with the following colors:

- **Blue:** Both the faulty "S12 actual values" (on the right) and the corresponding parameter groups (on the left) are marked in blue.

When you move the mouse pointer over the field marked in blue, a tooltip for the indicated error is shown.

- **White:** Parameter groups are marked in white if it is not possible to indicate their status.

This can have the following reasons:

- The "Assist S12" parameterization tool was started; no data has been uploaded yet.
- Data has been uploaded, but not downloaded yet. The blocks cannot be marked in green without a download.

- **Green:** No plausibility error

9.1.6 Status bar

The status bar indicates the status of the parameterization:

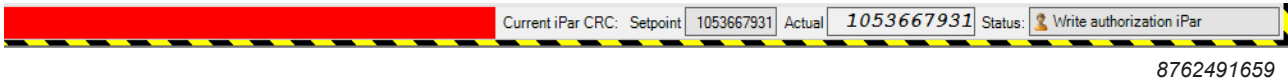

8762491659

After uploading the data, the current parameterization status of the S12 safety option is shown on the left. On the left in the figure above, a faulty, invalid parameter setting is shown highlighted in red. Next to it, the iPar CRC values with all setpoint and actual values is shown (setpoint = entire iPar CRC value of all parameters in the "input value" column; actual = entire iPar CRC value of the current S12 parameters). On the very right, the access state of the S12 safety option is shown with the following possible values:

- Connection request received (only when connecting the S12 safety option)
- Read access to iPar parameters
- Write authorization to iPar (additional write authorization with parameterization password. The F parameters in the S12 safety option can only be changed in this mode).
- Not connected (there is no valid connection)

9.1.7 Change password

The password offers protection from unintentional access. It does not safeguard the configuration.

The following preset passwords are available:

- Default password: **sew_s12**
- Master password: **sew_s12m**

INFORMATION



Change the default password with your first access.

To change the password, proceed as follows:

1. Move the mouse pointer (no clicking) over the "Change password" area [1]:
The input window [2] opens.

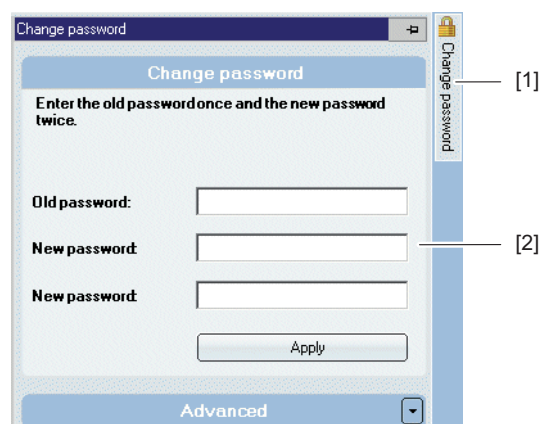

8776482571

2. To change the password, enter the old password and then twice the new password in the input window [2].

3. Click on [Apply] to confirm your entries.

You can undo password changes by entering the master password "sew_s12m" in the password prompt. The default password "sew_s12" is now restored. The master password is only accepted in the "Give write authorization" window.

9.2 Data management

General note on data management: The person starting up or operating the S12 safety option must ensure the availability of the current parameter set. The "Assist S12" parameterization tool offers suitable mechanisms for this (save, import/export).

9.2.1 Project-relevant files

The following 3 files are important for the parameterization process with the "Assist S12" parameterization tool. They are stored in the project directory of MOVITools® MotionStudio:

- **Configuration file "xxx.vd0"**

The name xxx is automatically derived from the MOVIFIT® signature during the configuration.

This file belongs to the standard configuration mechanism (export, import, upload, download, etc.) of MOVITools® MotionStudio. It also contains diagnostic parameters that are not safety-relevant for the S12 safety option, such as the serial number or the content of the error memory. It does not contain the safety-related F parameters.

In contrast with configuration files of non-safety-related devices, this file cannot be used for direct parameterization of the S12 safety option.

- **Acceptance protocol "S12Protocol-xxx-yyy.pdf"**

xxx stands for the serial number of the S12 safety option, yyy for the creation time of the file.

This file does not belong to the standard offline mechanism of MOVITools® MotionStudio. The "Assist S12" parameterization tool automatically uses the right file as soon as the parameterization tool has read out the serial number (online when establishing a definitive connection with the S12 safety option, or offline from the *.vd0 file).

This file can only be created online during the verification process (verification of the set parameters).

This file contains the system information and the F parameter values.

- **Last opened file "lastOpened_xxx.s12par"**

xxx stands for the serial number of the S12 safety option.

This file does not belong to the standard configuration mechanism of MOVITools® MotionStudio. The "Assist S12" parameterization tool automatically uses the right file as soon as the serial number is read (online when establishing a definitive connection with the S12 safety option, or offline from the vd0 file).

This file contains the setpoints of the F parameters set last in the "Assist S12" parameterization tool. It cannot be downloaded directly to the S12 safety option. The user has to go through the parameterization process of the "Assist S12" parameterization tool.

The directory in which the mentioned files are stored depend on whether the MOVIFIT® device was configured with the S12 safety option or not. Note that the S12 safety option is always configured together with the MOVIFIT® device. The directories are based on the "MotionStudio project folder" that is defined in "New project" dialog in MotionStudio.

The target directory and name form the name of the basic folder of this MotionStudio project.

9.2.2 Data management with non-configured S12 safety option

In the non-configured state (i.e. there is a MotionStudio project, but the MOVIFIT® unit with safety option has not been connected yet to the project view), you can only work online.

In this case, there is no configuration file that can be used as a basis for offline mode.

The data of the "Assist S12" parameterization tool is stored in the user directory of MOVITOOLS® MotionStudio.

Example:

The MotionStudio project folder is `C:\Users\USERNAME\Documents\SEW\MotionStudio\MMSProjektS12`

At first, this directory only contains the project file `MMSProjektS12.sewproj`. The subfolder `\UserData` is still empty.

After completion of the parameterization process (online), `\UserData` contains the following file and a subdirectory:

- `lastOpened_01.1241714603.0001.08.s12par`
- Subdirectory `\S12Protocol-01.1241714603.0001.08` with the PDF protocol file created during the parameterization process.

In this example, "01.1241714603.0001.08" is to be the serial number of the S12 safety option.

For each S12 safety option connected to other MOVIFIT® units, these files and the subdirectory are created with the respective serial number.

Each verification of the same unit (= same serial number) generates another PDF file in the folder with a new creation time in the file name.

9.2.3 Data management with configured S12 safety option

In the configured state (i.e. there is a project for the MOVIFIT® unit with the S12 safety option), you can work online or offline. In this case, there is a configuration file that is used as a basis for offline mode.

You can only configure a MOVIFIT® unit together with an S12 safety option. The S12 safety option cannot be configured separately.

The data of the "Assist S12" parameterization tool is stored in the MOVITOOLS® MotionStudio project in the device directory of the S12 safety option.

Example:

The MotionStudio project folder is `C:\Users\USERNAME\Documents\SEW\MotionStudio\MMSProjektS12`

At first, this directory only contains the project file `MMSProjektS12.sewproj`. The subdirectory `\Devices` has been added.

\Devices now contains a subdirectory (the name of which has been derived from the MOVIFIT® signature "MovifitS12" during the configuration process) for the S12 safety option: \MovifitS12 - O_1.

The directory \MovifitS12 - O_1 contains the following file and subdirectory:

- lastOpened_01.1241714603.0001.08.s12par
- Subdirectory \S12Protocol-01.1241714603.0001.08 with the PDF protocol file created during the parameterization process.

In this example, "01.1241714603.0001.08" is to be the serial number of the S12 safety option.

For each S12 safety option connected to other MOVIFIT® units, these files and the subdirectory are created with the respective serial number.

Each verification of the same unit (= same serial number) generates another PDF file in the folder with a new creation time in the file name.

Startup before configuration

If the S12 safety option has been started up before the configuration process in MOVITOOLS® MotionStudio, any data has been saved in the \UserData directory of MOVITOOLS® MotionStudio.

When the "Assist S12" parameterization tool is started after the configuration process, the following file is copied once:

- lastOpened_...s12par

Source directory of the copying process:

```
C:\Users\USERNAME\Documents\SEW\MotionStudio\MMSProjektS12\UserData
```

Target directory of the copying process:

```
C:\Users\USERNAME\Documents\SEW\MotionStudio\MMSProjektS12\Devices\Devicename
```

The folder with acceptance protocol files is copied as well, if it exists.

9.3 Functional description

9.3.1 Parameter setting procedure

Assist S12 provides a guided parameterization procedure for the parameterization of the S12 safety option.

The parameterization process basically looks as follows:

- Enter setpoints in the "Assist S12" parameterization tool in the left input value column.
- The "Download" function sends the values to the S12 safety option.
- The S12 safety option checks the transmitted setpoints for consistency and plausibility.
- After a successful transmission, you can check the parameterization with a first functional test.
- Compare all input values and actual values and verify their consistency.
- The verification process is completed by clicking on the [Finish] button.

9.3.2 Establishing a connection

After the start of the parameterization tool "Assist S12" in MOVITOOLS® MotionStudio, a window is displayed where the serial number of the device must be entered:

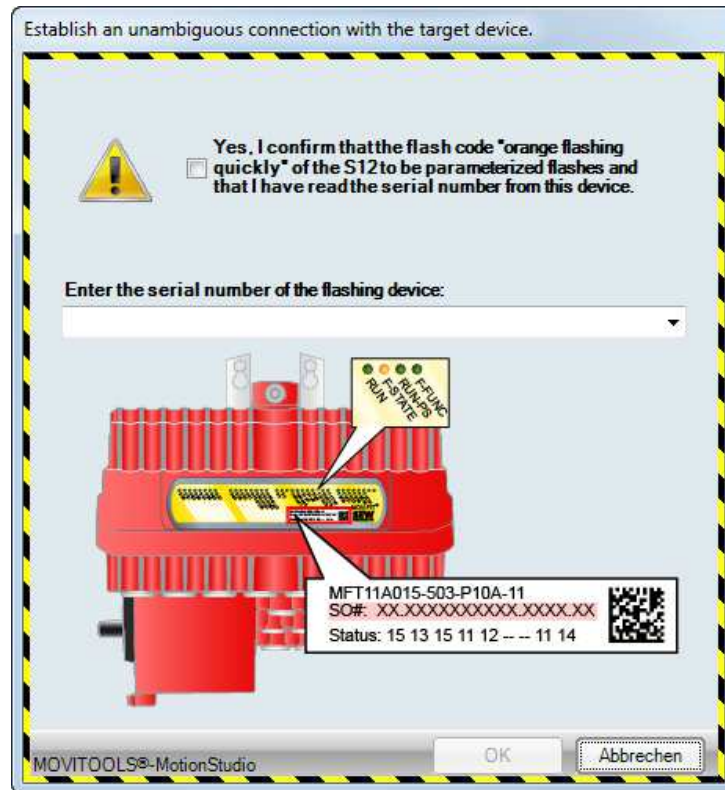

8763895051

When the "Assist S12" parameterization tool is opened, an LED of the connected S12 safety option starts flashing in a certain way. Read off the serial number from the S12 safety option with the flashing "F State LED" and enter it.

The serial number is sent back to the connected S12 safety option and checked there. This process ensures that the S12 safety option selected at the PC is the desired S12 safety option.

Note: You only have to enter the serial number for a certain device when you establish a connection for the first time. If you want to re-establish a connection with the device at a later time, simply select the serial number from the drop-down list.

When connecting the "Assist S12" parameterization tool with a certain S12 safety option (which can be identified via the serial number) for the first time, the default set-points are used. You can always restore these default values by clicking on the [New] button.

9.3.3 Parameterization

Upload the current parameter settings of the device

Click on the [Upload] button to upload the current parameter settings of the S12 safety option to the "Assist S12" parameterization tool. The uploaded values are shown in the "S12 actual value" column. This is to read out the current parameterization; it can also be done during operation.

Enter the parameterization

Double-click the parameter directories and enter the setpoints in the respective fields in the "input value" column.

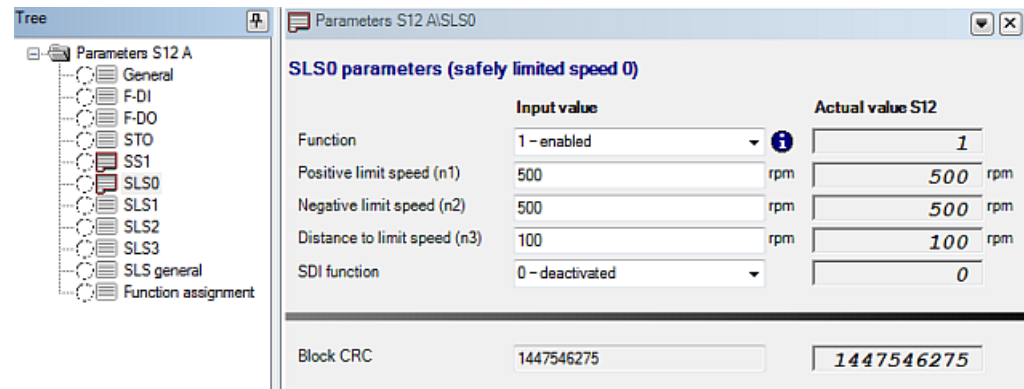

9007208014821515

Download the parameter set to the device

Click on the [Download] button to download the parameter set to the S12 safety option. The download is password-protected.

Enter password

Standard password (default): **sew_s12**

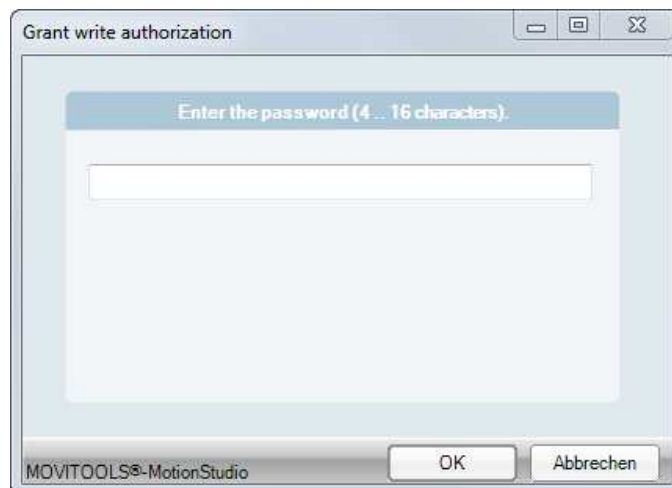

8764828683

Identify and correct plausibility errors

Identify any plausibility errors based on their color marking. For detailed information, refer to chapter "Plausibility error indication" (→ 103).

Verify the parameterization

If the S12 safety option does not detect any plausibility error, the individual parameters are displayed with a check box, which you have to tick for verification. Go through all parameter groups, check that your input values correspond with the read-back actual values in the S12 safety option, and tick all blocks that are correct. If you adjust any parameters here, you have to download the parameter settings again.

Once you have ticked (verified) all parameter groups, the [Finish] button becomes active.

	Input value		Actual value S12
Function	1 - enabled		1
Positive limit speed (n1)	500	rpm	500 rpm
Negative limit speed (n2)	500	rpm	500 rpm
Distance to limit speed (n3)	100	rpm	100 rpm
SDI function	0 - deactivated		0

Block CRC: 1447546275 1447546275 Verified

12202231947

Changing the parameter settings

The original process is shortened because verified data is already available:

- **Automatic recovery of the last setpoints**

When you exit the "Assist S12" parameterization tool, the setpoints for each parameterized S12 safety option are saved locally on the PC.

When you open the "Assist S12" parameterization tool again, these setpoints are automatically shown in the "Input values" column.

- **Verification of changed parameter blocks only**

If you change individual parts of the parameter set, you only have to re-verify the changed blocks.

Unchanged parameter blocks are shown as verified ("ticked off") and can no longer be changed; otherwise, they have to be verified again.

The following figure shows the difference between verified parameter blocks and non-verified parameter blocks:

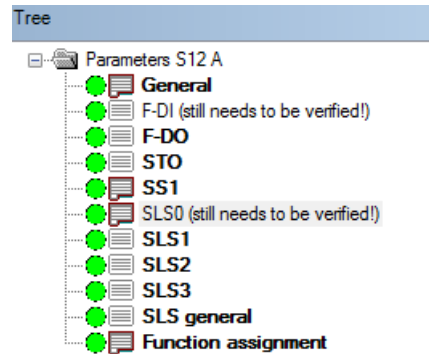

9007208019804043

- The names of unchanged parameter blocks are displayed in "bold".
The names of parameter blocks that still need to be verified are shown "normally".
In addition, "still needs to be verified" is shown next to the parameter block designation.

Parameter display

To show the current parameter settings, proceed as follows:

- Click [Upload].
The current parameter settings are uploaded and shown in the actual value columns.

The actual values of the S12 safety option are shown via an independent channel in the "Assist S12" parameterization tool. The "Assist S12" parameterization tool cannot interpret this data.

The user compares the iPar CRCs of the setpoint and actual values which shows whether the setpoint and actual values are identical.

9.3.4 Validation

Click the [Finish] button to tell the S12 option that you have verified all parameters.

Create acceptance protocol

The "Assist S12" parameterization tool creates a PDF file for validation and documentation, the so-called acceptance protocol. It contains the parameter settings, a checksum, a parameterization counter, and a system description. You can determine the content of this system description in a dialog window.

This dialog window appears automatically when you click the [Finish] button.

The acceptance protocol can be printed out and used in the validation of the system. Here, too, you can tick off the individual parameter blocks that have already been validated.

When at least one protocol file has been created, the [Protocol] button becomes active.

You can open the last generated protocol, or select and open a protocol from the drop-down list of generated protocols.

9.4 Device data

The area "device data" displays the following data:

- Serial number
- Device signature
- Device type
- Firmware part number
- Release number of the connected S12 safety option

9.5 Status displays

The "Status displays" block shows the system status with error messages, F state LED, F address, parameterization counter, and CRC values for the F parameters. Next to this, the PROFIsafe status and F-PLC parameters are displayed.

For detailed information, refer to chapter "Diagnostics with Assist S12" (→  138).

9.6 Display and status of the safety functions

The "Safety functions" block shows information about the inputs and outputs (F-DI and F-DO) and about the safety functions of the S12 safety option.

9.6.1 Overview

The following figure shows the display elements for the "Safety functions" block.

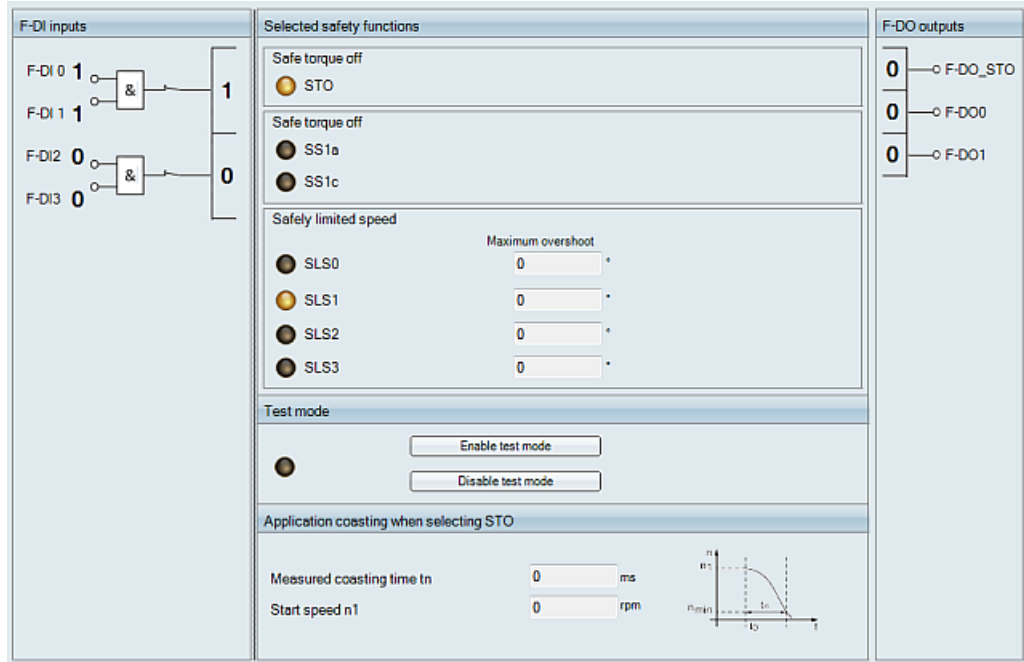

9007208025379851

The following pages describe the display elements in detail.

9.6.2 Safety function status

The status of the safety functions is displayed with the following LED colors.

LED color	Meaning
Yellow	Function selected
Light gray	Connection interrupted
Black	Function not active

INFORMATION



The status displays in the "Assist S12" parameterization tool are NOT safety-related and can be faulty.

They are only for diagnostics purposes.

9.6.3 F-DI inputs

F-DIs are displayed in the left part of the window with 4 or 8 inputs, depending on the variant (S12A or S12B). The inputs can be parameterized as 1-channel or 2-channel inputs. With 2-channel parameterization, a difference is made between equivalent and non-equivalent connection (see figure for example 2).

On the left margin of the F-DI block, the detected input levels of the safety-related F-DI inputs are shown; on the right margin, the corresponding F-DI process values are shown. They are also used to control the safety functions and are output via the safe process input data.

When the *IO error impact* parameter is set to "entire assembly", not only the process value of the F-DI affected by the error goes to safe state, but the process values of all other F-DIs as well. This status is shown by open switches between the F-DI input signal and the F-DI process values.

Example 1: 4 F-DI 1-channel, not interlocking

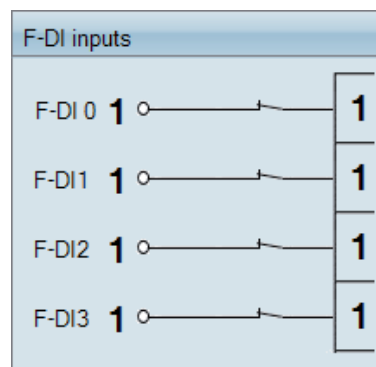

8770917643

Example 2: 2 F-DI 2-channel combined to one input (equivalent-switching)

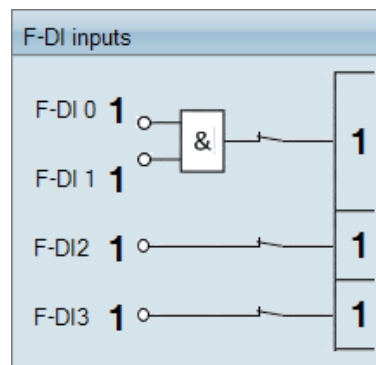

8770921995

Example 3: 2 F-DI programmed to interlocking

The F-DIs can be programmed to interlocking"" (→ 82). A lock indicates that the process values of an F-DI are in a locked state. In an error state (switch open) or when the input signal is 0, the lock symbol is not displayed.

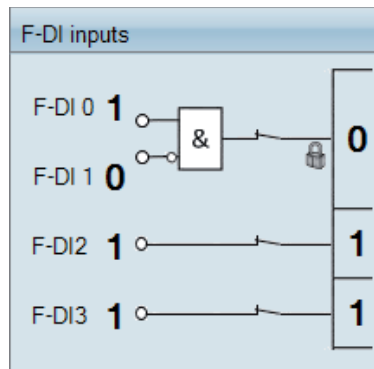

8772053131

The following figure shows the unlocked F-DI after acknowledgement:

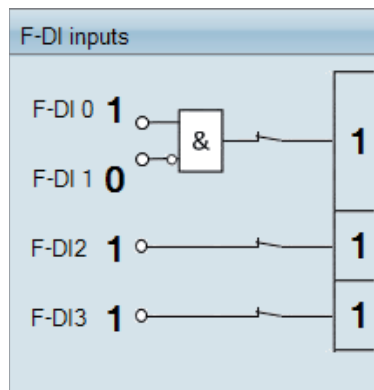

8772060811

Text conventions

The following 6 elements are used for representing F-DIs.

Element	Meaning/example
Designation of input	Text that designates the input (e.g. F-DI0)
Value of the input signal (signal level)	1: Voltage connected 0: No voltage or error
Input link	Solid line for 1-channel inputs Logic gate of two F-DI with 2-channel programming
Switch	A closed switch indicates that no error was detected in the input evaluation and that the process value of the F-DI / the F-DI pair is used to control the safety functions and to form the process input data. In case of an error, the switch is displayed as open.
Interlocking state	Represented by a lock in front of the process value of the F-DI / F-DI pair (if the input signal is "1" but the input is locked and therefore the process value is "0").

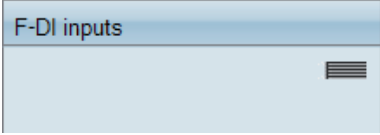
Element	Meaning/example
Process value of the F-DI or F-DI pair	<p>If it is not possible to give information on terminal programming and assignment because the connection to the S12 safety option is interrupted, the F-DIs are displayed as a small rectangle.</p> <p>Displayed in a small box on the right margin of the F-DI block:</p>  <p>8772067467</p>

9.6.4 F-DO outputs

The F-DOs are shown in the right part of the window. They cannot be programmed.

9.6.5 Test mode

You can switch the test mode on and off in the "Safety functions" block.

The test mode is the only area in which values of the S12 safety option are not only displayed, but can also be controlled by the user via the PC.

As the test mode can also be switched on and off with a process data bit via fieldbus, note the following:

The activation signal for test mode via the "Assist S12" parameterization tool is linked with the activation signal via process data with an OR operation. The test mode is activated with a rising edge in one of both activation signals. To deactivate the test mode, both activation signals must be set to "off".

If the test mode has been activated via process data, control via the "Assist S12" parameterization tool is limited.

The test mode is deactivated automatically after 5 minutes. This time frame starts with the first activation of the test mode and cannot be extended by further activation edges.

9.6.6 Application coasting when selecting STO

If the "Coasting time measurement" (→ 84) function is used, the measured coasting time (in ms) and the starting speed at the time of activation of the STO function (in rpm) are displayed in the "Safety functions" mask in the area "Application coasting when selecting STO".

9.7 Process data

In the "Process data" block, you can see the process data that are exchanged between the higher-level controller and the MOVIFIT® device.

Process data are only displayed with PROFIsafe connection via PROFIBUS or PROFINET.

In the upper part of the window, the process data are displayed in hexadecimal format. In the lower part of the window, you can display individual bits by clicking on the drop-down list of the corresponding process data word (PI., PO.).

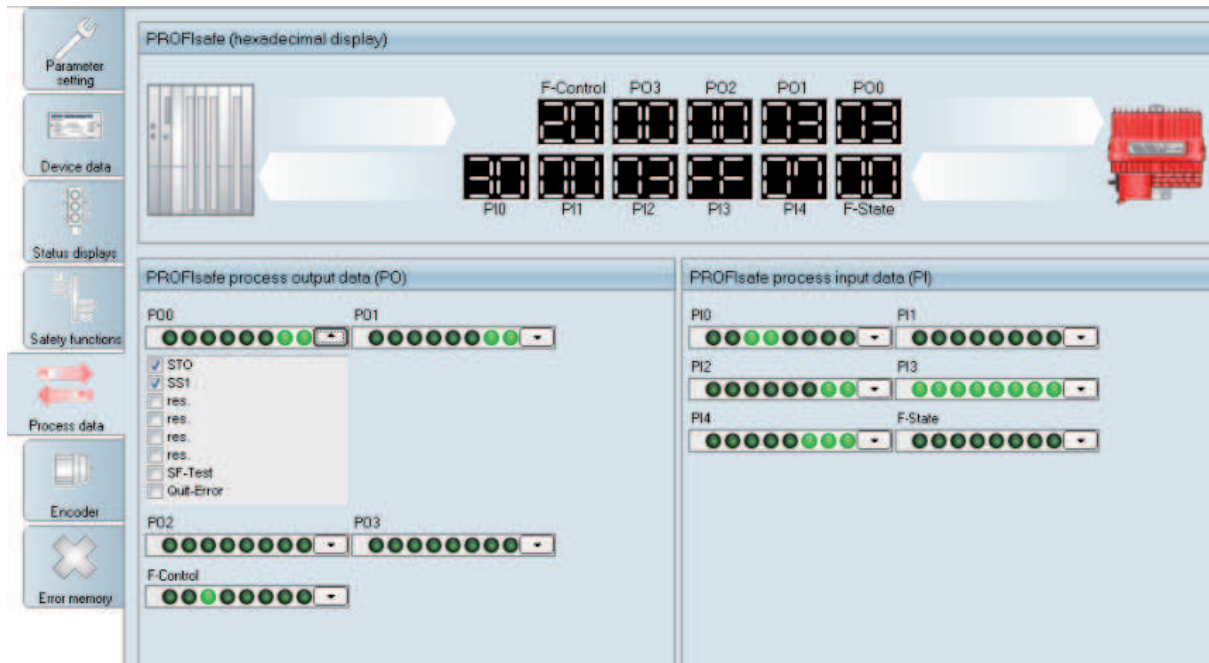

8772108939

9.8 Encoder

The "Encoder" block shows the speed measured by the encoder. It also indicates whether the parameterized minimum speed of the motor is exceeded.

INFORMATION



In applications without EI7C FS built-in encoder, "Minimum speed motor exceeded" is always "Yes".

9.9 Error memory

The "Error memory" block shows the two error memories of the S12 safety option.

In the upper part of the window, the "current errors" are shown. The entries in the "current errors" list are reset if the S12 safety option is switched off. Acknowledgeable errors are deleted after they are acknowledged.

The content of the lower error memory is preserved after a reconnection or acknowledgement. This memory can be deleted with the [Reset error memory] button. The memory is a circular buffer. The new entries overwrite the oldest entries as soon as the memory capacity limit is reached.

The specified time is the duty time of the S12 safety option. It is given in seconds. For comparison reasons, the current duty time is shown to the left of the [Reset error memory] button (in the example below, the current duty time is 4453740 s).

Current error	
Error Channel A	Error Channel B
0	--
1	--
2	--
3	--
4	--
5	--
6	--
7	--
8	--

Error memory 4453740s							Reset error memory
Channel A			Channel B				
	Error	Time [s]	Range	Error	Time [s]	Range	
0	2009E365 Safe process data set	1524225	SP error	902201 Encoder signal monitoring error	1603573	Encoder	
1	2009E365 Safe process data set	1520613	SP error	902201 Encoder signal monitoring error	1548320	Encoder	
2	2009E365 Safe process data set	1499682	SP error	902201 Encoder signal monitoring error	1548311	Encoder	
3	2009E365 Safe process data set	1498112	SP error	902201 Encoder signal monitoring error	1548282	Encoder	
4	2009E365 Safe process data set	1497403	SP error	902201 Encoder signal monitoring error	1524207	Encoder	
5	2009E365 Safe process data set	1497391	SP error	902201 Encoder signal monitoring error	1520607	Encoder	
6	2009E365 Safe process data set	1497381	SP error	2009E365 Safe process data set	1499682	SP error	
7	932206 Faulty track signals	1497370	Encoder	2009E365 Safe process data set	1498112	SP error	
8	2009E365 Safe process data set	1496344	SP error	326719 HW diagnostics DO internal error	1498102	F-DO error	
9	--	--	--	326719 HW diagnostics DO internal error	1498076	F-DO error	
10	--	--	--	326719 HW diagnostics DO internal error	1498069	F-DO error	
11	--	--	--	2009E365 Safe process data set	1497403	SP error	
12	--	--	--	2009E365 Safe process data set	1497391	SP error	
13	--	--	--	2009E365 Safe process data set	1497381	SP error	
14	--	--	--	902201 Encoder signal monitoring error	1497347	Encoder	
15	--	--	--	902201 Encoder signal monitoring error	1496980	Encoder	

8773153803

For detailed information, refer to chapter "Diagnostics with Assist S12" / "Error memory" (→ 140).

10 Data exchange with higher-level controller

10.1 Introduction

MOVIFIT® devices with integrated S12 safety option support parallel operation of standard and safety-related communication via a bus system or network. You can run safety-related PROFIsafe communication via PROFIBUS DP and PROFINET IO.

The transmitted bus messages contain standard information for conventional MOVIFIT® operation and the PROFIsafe safety telegram. Depending on the configuration, the maximum available expansion level enables parallel exchanges of PROFIsafe safety data, the parameter channel, and process data between the bus master and the MOVIFIT® device.

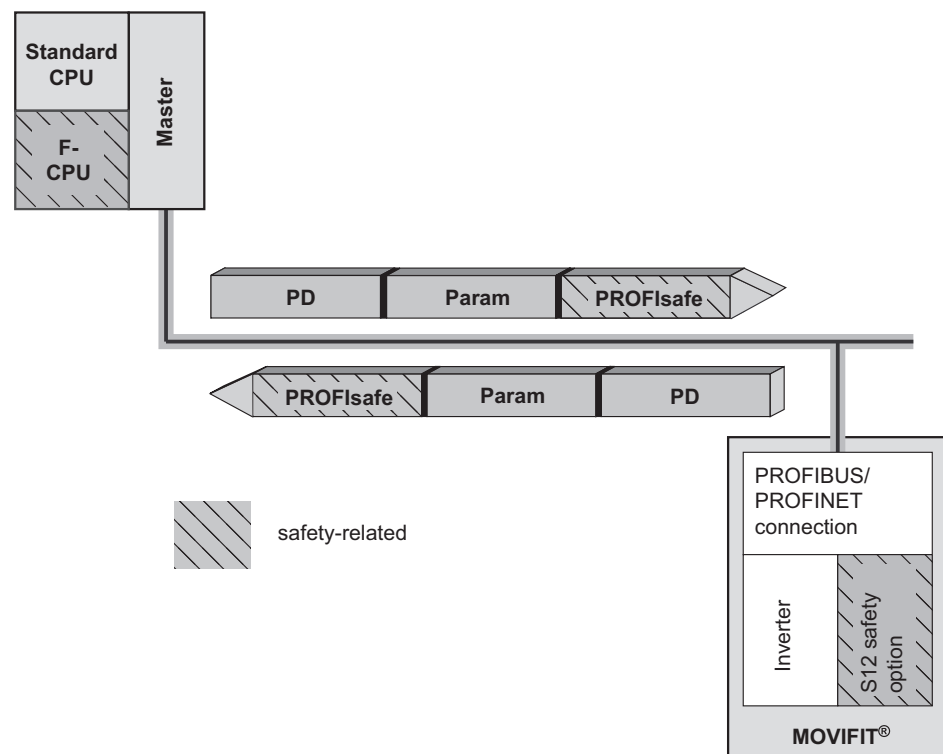

10.2 F periphery access of the S12 safety option in STEP 7

For safety-related communication, the S12 safety option needs a total of 9 bytes for input data and 8 bytes for output data for the PROFIsafe telegram part and occupies them in the process image. Of these, 5 input bytes and 4 output bytes constitute the actual safety-related I/O data (F user data), and the remaining 4 bytes are required for telegram protection in accordance with the PROFIsafe specifications.

10.2.1 F periphery DB of S12 safety option

During compilation in the configuration tool (HW Config), the system automatically generates an F periphery DB for every S12 safety option. The F periphery DB offers a user interface in which you can evaluate or control variables in the safety program.

The symbolic name consists of the invariable prefix "F", the start address of the F periphery, and the name entered in the object properties during configuration for the F periphery (e.g. F00008_198).

The following table shows the F periphery DB of the S12 safety option:

	Address	Symbol	Data type	Function	Default
User-controllable variables	DBX0.0	"F00008_198.PASS_ON"	Boolean	1 = activate passivation	0
	DBX0.1	"F00008_198.ACK_NEC"	Boolean	1 = acknowledgement required for reintegration with S12 safety option	1
	DBX0.2	"F00008_198.ACK_REI"	Boolean	1 = acknowledgement for reintegration	0
	DBX0.3	"F00008_198.IPAR_EN"	Boolean	Variable for resetting parameters (not supported by S12 safety option)	0
Variables that can be evaluated	DBX2.0	"F00008_198.PASS_OUT"	Boolean	Run passivation	1
	DBX2.1	"F00008_198.QBAD"	Boolean	1 = substitute values are output	1
	DBX2.2	"F00008_198.ACK_REQ"	Boolean	1 = acknowledgement required for reintegration	0
	DBX2.3	"F00008_198.IPAR_OK "	Boolean	Variable for resetting parameters (not supported by S12 safety option)	0
	DBB3	"F00008_198.DIAG"	Byte	Service information	

PASS_ON

This variable lets you activate passivation of the S12 safety option. Provided that PASS_ON = "1", the F periphery is passivated.

ACK_NEC

After a fault has been corrected, the S12 safety option is reintegrated, depending on ACK_NEC.

- ACK_NEC = 0: Automatic reintegration
- ACK_NEC = 1: Automatic reintegration following acknowledgement by the user

WARNING

The variable ACK_NEC = 0 may only be parameterized if automatic reintegration is safe for the process in question.

Severe or fatal injuries.

- Check if automatic reintegration is permitted for the process in question.



ACK_REI

In order to reintegrate the S12 safety option after the fault has been corrected, user acknowledgement with positive edge of variable ACK_REI is required. Acknowledgement is only possible if variable ACK_REQ = 1.

ACK_REQ

The F control system sets ACK_REQ = 1 after all faults in the data exchange with the S12 safety option have been corrected. After successful acknowledgement, the F control system sets ACK_REQ = 0.

PASS_OUT

Indicates whether the S12 safety option has been passivated. Substitute values are output.

QBAD

Error in the data exchange with the S12 safety option. Indicates passivation. Substitute values are output.

DIAG

For service information purposes, the variable DIAG supplies non-failsafe information about faults that have occurred in the F control system. For further information, refer to the relevant F control system manual.

10.2.2 F user data of S12 safety option

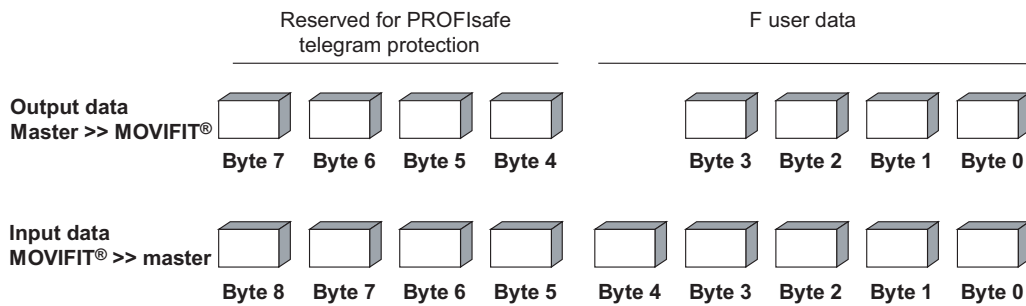

8469829771

F process output data

Byte	Bit	Name	Value	Description
0	0	STO	0	STO is selected.
			1	STO is not selected.
	1	SS1	0	SS1 function is selected (execution of parameterized SS1(a) or SS1(c) function).
			1	SS1 function is not selected.
	2 – 5	Reserved	–	–
	6	SF test	0	Test mode for safety functions is not selected.
			1	Test mode for safety functions is selected (edge 0/1).
7	Acknowledge error	0	For 0/1 edge: Acknowledgement of pending errors and unlocking of interlocking F-DI inputs. Information: After the acknowledgement, the bit should be reset to "0" to avoid unintentional acknowledgements during startup and reintegration of the controller.	
		1		
1	0	SLS0	0	The SLS0 safety function is selected.
			1	The SLS0 safety function is not selected.
	1	SLS1	0	The SLS1 safety function is selected.
			1	The SLS1 safety function is not selected.
	2	SLS2	0	The SLS2 safety function is selected.
			1	The SLS2 safety function is not selected.
	3	SLS3	0	The SLS3 safety function is selected.
1			The SLS3 safety function is not selected.	
4 – 7	Reserved	–	–	
Byte	Bit	Name	Value	Description
2	0	F-DO00	0	F-DO00 output is not selected; the safety-rated output is open.
			1	F-DO00 output is selected; the safety-rated output is closed.
	1	F-DO01	0	F-DO01 output is not selected; the safety-rated output is open.
			1	F-DO01 output is selected; the safety-rated output is closed.
2 – 7	Reserved	–	–	
3	0 – 7	Reserved	–	–

F process input data

Byte	Bit	Name	Value	Description
0	0	STO active	0	The STO function is not active; 24 V supply voltage is switched on, safe disconnection for the connected drive is not effective or an error has occurred at the output.
			1	The STO function reports the status "STO active", and all outputs parameterized to STO are without voltage.
	1	SS1 active	0	The SS1 function is not active. The function is not selected, or an error has occurred. The STO status is not part of the SS1 status and must be consulted via bit 0.
			1	The SS1 function is active. The drive is brought to a safe stop with a safely monitored ramp with SS1 (a) or after the delay time with SS1(c). There is always a transition to STO.
	2 – 3	Reserved	–	–
	4	Standstill	0	Standstill is not active, axis is rotating.
			1	Standstill is active, standstill ($n < n_{min}$) detected
	5	ASF error	0	Speed error in active safety function SS1(a) or SLS/SDI.
			1	No speed error in any active safety function.
	6	SF test active	0	Test mode for safety functions is not active.
			1	Test mode for safety functions is active.
	7	Error	0	The S12 safety option is running without any errors.
			1	At least one error is active in the S12 safety option.
	1	0	SLS0 active	0
1				The SLS0 safety function is active.
1		SLS1 active	0	The SLS1 safety function is not active, or an error has occurred.
			1	The SLS1 safety function is active.
2		SLS2 active	0	The SLS2 safety function is not active, or an error has occurred.
			1	The SLS2 safety function is active.
3		SLS3 active	0	The SLS3 safety function is not active, or an error has occurred.
			1	The SLS3 safety function is active.
4 – 7		Reserved	–	–

Byte	Bit	Name	Value	Description
2	0	F-DI00	0	Process value of digital, safety-related input F-DI00, no voltage or error present.
			1	Process value of digital, safety-related input F-DI00, voltage present.
	1	F-DI01	0	Process value of digital, safety-related input F-DI01, no voltage or error present.
			1	Process value of digital, safety-related input F-DI01, voltage present.
	2	F-DI02	0	Process value of digital, safety-related input F-DI02, no voltage or error present.
			1	Process value of digital, safety-related input F-DI02, voltage present.
	3	F-DI03	0	Process value of digital, safety-related input F-DI03, no voltage or error present.
			1	Process value of digital, safety-related input F-DI03, voltage present.
	4	F-DI04	0	Process value of digital, safety-related input F-DI04, no voltage or error present.
			1	Process value of digital, safety-related input F-DI04, voltage present.
	5	F-DI05	0	Process value of digital, safety-related input F-DI05, no voltage or error present.
			1	Process value of digital, safety-related input F-DI05, voltage present.
	6	F-DI06	0	Process value of digital, safety-related input F-DI06, no voltage or error present.
			1	Process value of digital, safety-related input F-DI06, voltage present.
7	F-DI07	0	Process value of digital, safety-related input F-DI07, no voltage or error present.	
		1	Process value of digital, safety-related input F-DI07, voltage present.	

Byte	Bit	Name	Value	Description
3	0	QFDI0	0	Qualifier F-DI00; "bad": The corresponding F-DI is transmitted with the substitute value.
			1	Qualifier F-DI00; "good": The corresponding F-DI is transmitted with the current process value.
	1	QFDI1	0	Qualifier F-DI01; "bad": The corresponding F-DI is transmitted with the substitute value.
			1	Qualifier F-DI01; "good": The corresponding F-DI is transmitted with the current process value.
	2	QFDI2	0	Qualifier F-DI02; "bad": The corresponding F-DI is transmitted with the substitute value.
			1	Qualifier F-DI02; "good": The corresponding F-DI is transmitted with the current process value.
	3	QFDI3	0	Qualifier F-DI03; "bad": The corresponding F-DI is transmitted with the substitute value.
			1	Qualifier F-DI03; "good": The corresponding F-DI is transmitted with the current process value.
	4	QFDI4	0	Qualifier F-DI04; "bad": The corresponding F-DI is transmitted with the substitute value.
			1	Qualifier F-DI04; "good": The corresponding F-DI is transmitted with the current process value.
	5	QFDI5	0	Qualifier F-DI05; "bad": The corresponding F-DI is transmitted with the substitute value.
			1	Qualifier F-DI05; "good": The corresponding F-DI is transmitted with the current process value.
	6	QFDI6	0	Qualifier F-DI06; "bad": The corresponding F-DI is transmitted with the substitute value.
			1	Qualifier F-DI06; "good": The corresponding F-DI is transmitted with the current process value.
7	QFDI7	0	Qualifier F-DI07; "bad": The corresponding F-DI is transmitted with the substitute value.	
		1	Qualifier F-DI07; "good": The corresponding F-DI is transmitted with the current process value.	
4	0	QFDO-STO	0	Qualifier QFDO-STO; "bad": The corresponding F-DO is switched off due to an error.
			1	Qualifier QFDO-STO; "good": The corresponding F-DO is switched via the current process value.
	1	QFDO0	0	Qualifier QFDO0; "bad": The corresponding F-DO is transmitted with the substitute value.
			1	Qualifier QFDO0; "good": The corresponding F-DO is transmitted with the current process value.
	2	QFDO1	0	Qualifier QFDO1; "bad": The corresponding F-DO is transmitted with the substitute value.
			1	Qualifier QFDO1; "good": The corresponding F-DO is transmitted with the current process value.
	3 – 7	Reserved	–	–

10.2.3 Activation examples for the S12 safety option

In the example for activating the failsafe functions of the S12 safety option, it is prerequisite that a safety program and a process group have been created, and that an F control program module is available.

You can activate the failsafe functions and the F periphery as well as the evaluation of the responses by the F periphery by using flags. Note that in STEP7, flags are only permitted for coupling between the standard user program and the safety program. Flags may not be used as buffers for F data.

INFORMATION



SEW-EURODRIVE accepts no liability for the information provided in this example. This example does not represent a customer-specific solution, its aim is simply to assist the reader.

The following table shows allocation of input/output addresses to flags:

Address	Symbol	Flag	Meaning	Comment
E 8.0	S12 PowerRe- moved	M 8.0	Feedback: safety-related output switched.	1-active
E 9.0	S12 SLS0 act- ive	M 9.0	Feedback: SLS0 active.	
E 10.0	S12 F-DI00	M 9.1	Status of the safety-related input F-DI00	
A 8.0	S12 STO	M 80.0	STO is selected.	0-active
A 9.0	S12 SLS0	M 90.0	SLS0 is selected.	
A 10.0	S12 F-DO01	M 90.1	Safety-related output DO01 is selected.	1-active
DB811.DBX0.0	"F00008_198". PASS_ON	M 10.0	Activating the passivation of the S12 safety option.	–
DB811.DBX0.1	"F00008_198". ACK_NEC	M 10.1	Parameterizing the reinteg- ration of S12 safety option.	
DB811.DBX0.2	"F00008_198". ACK_REI	M 10.2	Activating the user ac- knowledgement for the S12 safety option.	
DB811.DBX2.0	"F00008_198". PASS_OUT	M 10.3	S12 safety option passiv- ated.	
DB811.DBX2.1	"F00008_198". QBAD	M 10.4	Error in the S12 safety op- tion.	
DB811.DBX2.2	"F00008_198". ACK_REQ	M 10.5	Indicates whether user ac- knowledgement is required for reintegration of the S12 safety option.	

Network 1 : Control STO

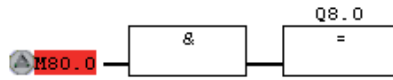

Network 2 : STO feedback



Network 3 : Control SLS0

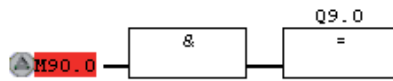

Network 4 : SLS feedback



8638278539

10 Data exchange with higher-level controller

F periphery access of the S12 safety option in STEP 7

Network 5 : F-feedback

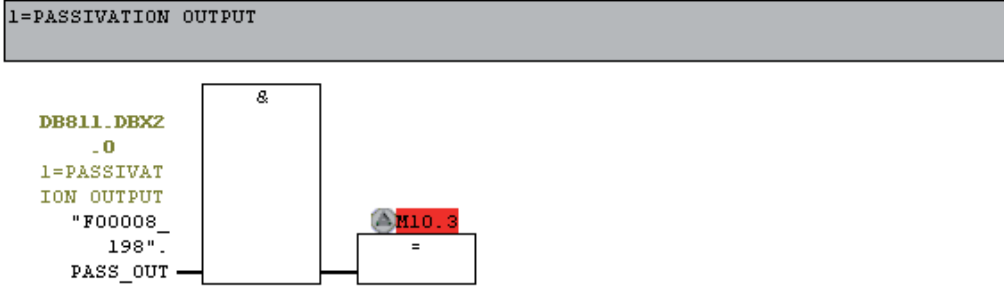

Network 6 : F-feedback

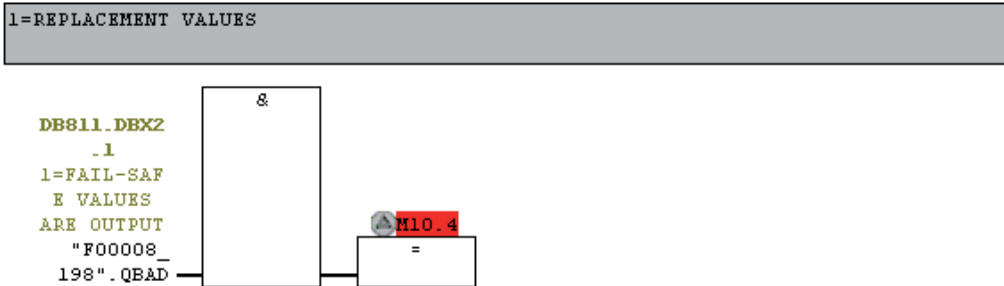

Network 7 : F-feedback

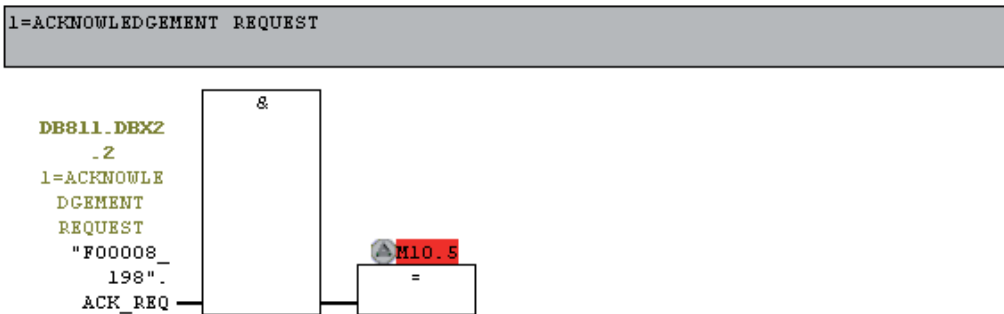

Network 8 : User can activate passivation

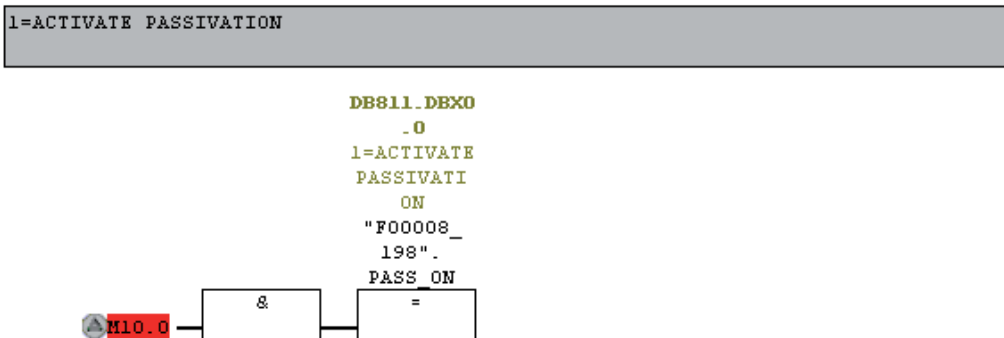

8640624395

- ACK_NEC = 0: Automatic reintegration
- ACK_NEC = 1: Automatic reintegration following acknowledgement by the user

22865268/EN – 06/2016

▲ WARNING



The variable ACK_NEC = 0 may only be parameterized if automatic reintegration is safe for the process in question.

Severe or fatal injuries.

- Check if automatic reintegration is permitted for the process in question.

☐ Network 9 : Parametrize the reintegration

l=ACKNOWLEDGEMENT NECESSARY

```
DB811.DBX0
-1
l=ACKNOWLEDGEMENT
NECESSARY
"FO0008_
198".
ACK_NEC
```

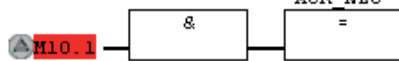

☐ Network 10 : User must acknowledge the reintegration of the F-device

l=ACKNOWLEDGEMENT FOR REINTEGRATION OF THE F-DEVICE

```
DB811.DBX0
-2
l=ACKNOWLEDGEMENT
FOR
REINTEGRATION
"FO0008_
198".
ACK_REI
```

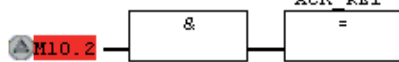

8640291339

11 Response times

Response times play a decisive role in the design and execution of safety functions of systems and machines. In order to match the response time to the requirements of a safety function, always take the entire system from sensor (or control device) to actuator into account. The following times are of particular importance in connection with the S12 safety option:

- Response times of the connected sensors
- PROFIsafe cycle time
- Processing time (cycle time) in the safety controller
- PROFIsafe monitoring time F_WD_Time
- Internal response times of S12 safety option
- Response time of actuators (e.g. frequency inverters)

Establish the response sequence for each safety function in your application and determine the maximum response time for each case considering the relevant manufacturer data. Observe the information in the safety documentation of the used safety controller.

For detailed information about the maximum response time of the S12 safety option, refer to chapter "Technical data of the S12 safety option" (→ 171). For detailed information about response time consideration for safety-related PROFIsafe communication, refer to the respective standard: IEC 61784-3-3.

12 Service

12.1 Diagnostics LEDs



▲ WARNING

Danger due to incorrect interpretation of the "FDI..", "FDO..", "F-FUNC" and "F-STATE" LEDs.

Severe or fatal injuries.

- The LEDs are not safety-related and may not be used as a safety device.

This chapter describes the option-specific LEDs for the S12 safety option. In the following figure, these LEDs are shown as dark.

The following figure shows an example of the S12A safety option:

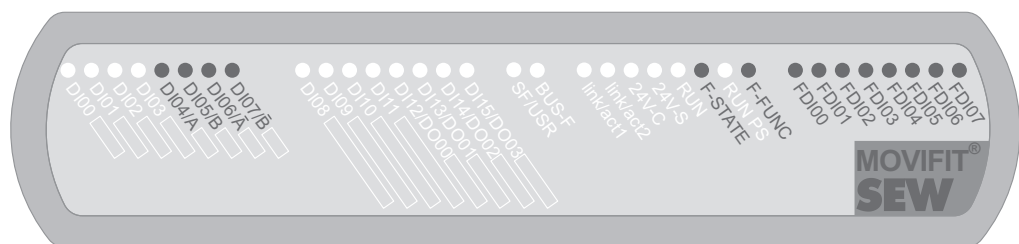

9007207954081291

The following figure shows an example of the S12B safety option:

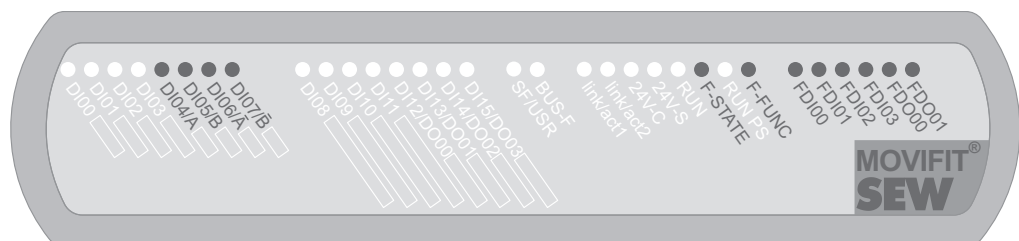

9007207954077579

12.1.1 "FDI.." LEDs

The following table shows the statuses of the "FDI.." LEDs:

LED	Meaning
Off	LOW level at input F-DI.. or open
	Parameterization is active.
Yellow Illuminated	HIGH level at input F-DI..
	Display test, 2 s after reset
Red Illuminated	Error at input F-DI.. (except discrepancy errors)

12.1.2 "FDO.." LEDs

The following table shows the statuses of the "FDO.." LEDs:

LED	Meaning
Off	F-DO.. output is inactive (switched off).
Yellow Illuminated	F-DO.. output is active.
	Display test, 2 s after reset
Red Illuminated	Error at output F-DO..

INFORMATION



The "FDO.." LEDs are only relevant for the S12A safety option.

12.1.3 "F-FUNC" LED

The following table shows the statuses of the "F-FUNC" LED:

LED	Meaning
Off	Safety function is not active or error at output F-DO_STO.
Yellow Illuminated	Drive is in safe torque off mode, F-DO_STO without voltage.
	Brake ramp is active (SLS, SS1a).
Yellow Flashing 250 ms cycle	
Yellow Flashing 1 s cycle	Speed monitoring is active (SLS).

12.1.4 "F-STATE" LED

The following table shows the statuses of the "F-STATE" LED:

LED	Meaning	Measure
Off	The S12 safety option is currently in the initialization phase. S12 safety option is not available. Verification is not completed (by switch-off/on or by bus startup)	<ul style="list-style-type: none"> • Check configuration of bus master. • Switch the unit off/on.
Yellow Illuminated	S12 safety option is in RUN mode, but safety parameters not verified yet.	<ul style="list-style-type: none"> • Perform verification of safety parameters.
Yellow Flashing	Flash code for identification of the device during authentication (entering the serial number in "Assist S12")	
Green Illuminated	S12 safety option is in RUN mode, verification of safety parameters completed.	-
Yellow/green Flashing	Test mode for drive safety functions is active.	-
Red Flashing	Error occurred (error can be acknowledged).	<ul style="list-style-type: none"> • Error diagnostics. • Correct the error and acknowledge via F host or programmed F-DI input.
Red Illuminated	An error has occurred. (Error cannot be acknowledged) No 24 V ₀ supply voltage	<ul style="list-style-type: none"> • Error diagnostics • Check voltage supply.

12.2 STO jumper plug



▲ WARNING

Safety-related disconnection of the MOVIFIT® drive is not possible when the STO jumper plug is used.

Severe or fatal injuries.

- You may only use the STO jumper plug when the MOVIFIT® drive does not fulfill any safety function.



▲ WARNING

Disabling of safety-related disconnection of other drive units due to parasitic voltages when using an STO jumper.

Severe or fatal injuries.

- You may only use the STO jumper when all incoming and outgoing STO connections have been removed from the drive unit.

The STO jumper plug can be connected to the X70F/X71F STO plug connector of the MOVIFIT® device. The STO jumper plug deactivates the safety functions of the MOVIFIT® device.

The following figure shows the STO jumper plug, part number 11747099:

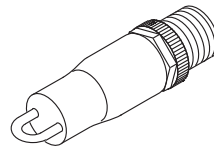

63050395932099851

12.3 X71F plug connector for safety-related disconnection (option)



▲ WARNING

No safety-related disconnection of the MOVIFIT® drive if the STO jumper plug is plugged in at the X71F plug connector.

Severe or fatal injuries.

- Do not use the 24 V output (+24V_C and 0V24_C) for safety-related applications with MOVIFIT® drives.
- You may only jumper the STO connection with 24 V when the MOVIFIT® drive is not used to fulfill any safety functions.

The following table shows information about this connection:

Function
Safety-related digital output F-DO_STO for safe torque off in the drive (STO)
Connection type
M12, 5-pole, female, A-coded
Wiring diagram
<p style="text-align: right;">17865149963</p>

Plug connector	Name	Function	Ter-minals	
X71F	1	+24V_C	+24 V supply for digital inputs – continuous voltage	X29/1
	2	F-DO_STO_M	Safety-related digital output F-DO_STO (sinking signal) for safe torque off in the drive (STO)	X45/15
	3	0V24_C	0V24 reference potential for digital inputs – continuous voltage	X29/2
	4	F-DO_STO_P	Safety-related digital output F-DO_STO (sourcing signal) for safe torque off in the drive (STO)	X45/5
	5	n.c.	Not connected	n.c.

12.4 Error states of the S12 safety option

INFORMATION



Depending on the safety controller used, other terms may be used for "passivation" and "reintegration" in the safety controller documentation. For detailed information, refer to the safety controller documentation.

12.4.1 Error in the safety section

The S12 safety option is able to detect various internal and external faults (at the safety-related inputs/outputs). For information on the types of error, exact responses, and how to correct the errors, refer to chapter "Error table of the S12 safety option".

The error response of the S12 safety option can be parameterized. For detailed information, refer to chapter "Parameter description" / "General information".

INFORMATION



In fieldbus operation, the S12 safety option is not passivated with every error.

12.4.2 PROFIsafe timeout

If the safety-related PROFIsafe communication is interrupted or delayed, the S12 safety option responds with passivation and assuming a safe status after the adjustable monitoring time "*F_WD_Time*" (see description of F parameters) has expired. After this time has expired, the relevant assembly is passivated in the safety controller, and the associated safety-related process values for the safety application are set to "0" (→ safe status).

▲ WARNING



Automation reintegration can also be set in the safety controller.

Severe or fatal injuries.

- This function must not be used in safety-related applications.

12.4.3 Safety diagnostics via PROFIBUS DP

The status of PROFIsafe communication and S12 safety option error messages is transmitted to the DP master via a status PDU in accordance with the PROFIBUS DPV1 standard.

The following figure shows the structure of the diagnostic data for PROFIsafe communication via slot 1. In slot 1, the F module for the S12 safety option is configured.

Byte 11 is used for transferring diagnostics messages. These are defined in the PROFIsafe specifications.

Bytes 12 and 13 transmit the status and error status of the S12 safety option to the higher-level DP master.

The figure below shows the structure of diagnostics data for PROFIBUS DPV1:

Status block							
Bytes 1...6	Byte 7	Byte 8	Byte 9	Byte 10	Byte 11	Byte 12	Byte 13
6 bytes Standard diagnostics	Header	Status Type	Slot Number	Status Specifier	Diag User Data 0	Diag User Data 1	Diag User Data 2
...	0x07	0x81	0x00	0x00	PROFIsafe	F-State 1	
	↑	↑	↑	↑	↑	↑	
	7 bytes module-specific Diagnostics	0x81 = Status block with status message	0x00 = Slot 1 (S12 safety option)	No DPV1 specifier	PROFIsafe diagnostic information in accordance with PROFIsafe profile V2.0	Cyclical F_State of the MOVIFIT®	

Diagnostic messages of the PROFIsafe layer

INFORMATION



For more information on the meaning and remedy of error messages, refer to the manuals on the PROFIBUS-DP master and to chapter "Error table of S12 safety option" (→ 146).

12.4.4 Safety diagnostics via PROFINET IO

The status of PROFIsafe communication and error messages of the S12 safety option are reported to the PROFINET IO controller, where they can then be diagnosed. For more information on diagnostics refer to the manual MOVIFIT® function level "Classic..." or "Technology...".

Diagnostic messages of the PROFIsafe layer

INFORMATION



For detailed information on the meaning and remedy of error messages, refer to the manuals on the PROFINET IO controller and to chapter "Error table of S12 safety option" (→ 146).

12.5 Diagnostics with Assist S12

12.5.1 Status displays

The following figure shows the "status displays" block.

The screenshot displays the 'Assist S12' diagnostic interface. On the left is a navigation menu with icons for: Parameter setting, Device data, Status displays (selected), Safety functions, Process data, Encoder, and Error memory. The main area is divided into three sections:

- System state:**
 - System state: 4 Normal operation
 - Error: Error in the communication
 - F-state LED: ● RUN, without verification
 - F address: 5
 - Current iPar CRC: 7a9d55e1 (hex) / 2057131489 (dez)
 - Verified iPar CRC: fe00a98a (hex) / 4261456266 (dez)
 - Parameterization counter: 48
- PROFISafe status:**
 - Communication connection status: S12 is in Data Exchange state. S12 is passivated. Communication error detected.
 - PROFISafe status: PSD_DATAEX
- F parameter from F-PLC:**
 - F address (F_D_address): 5
 - F monitoring time (F_WD_Time): 150 ms
 - iPar CRC (F_iPar_CRC): fe00a98a (hex) / 4261456266 (dez)

At the bottom left of the interface, it says '48 Downloads'.

8773724299

The following table lists the values of the status display.

Display group	Display parameters	Display value/status	Meaning
System state	System state	0 - initialization	
		1 - parameterization	Processing and transferring of parameters.
		2 - verification completed	The parameter settings were verified. System waiting for restart or bus restart (safe state).
		4 - run	Normal operation.
		5 - stopping	Exiting "run" status during verification or re-parameterization. The inverter goes to safe status (STO).
	Error(s)	Displays the current error code	For details on the error code, refer to the following page.
	F-state LED	Off	Option not available; 24V_O missing; initialization phase active.
		Yellow	iPar parameters not verified yet.
		Flashing yellow	Device identification.
		Green	System status RUN; verification completed.
		Flashing yellow/green	Test mode active.
		Flashes red	Error status can be acknowledged.
		Red	Error status cannot be acknowledged
	F address	Display of set F address (For detailed information about F address settings, refer to chapter "Setting the PROFIsafe address" (→ 91)).	
	Current iPar CRC	Current and verified iPar CRC values.	
Verified iPar CRC			
Parameterization counter	Displays the number of parameterization processes.		
PROFIsafe status	Communication connection status	Descriptive text for communication status.	
	PROFIsafe status	Communication status ID.	

Display group	Display parameters	Display value/status	Meaning
F parameters from F PLC	F address F monitoring time iPar CRC		Displays the F parameters set in the F PLC.

12.5.2 Error memory

The following figure shows the "error memory" block.

	Error Channel A	Error Channel B
0	-	-
1	-	-
2	-	-
3	-	-
4	-	-
5	-	-
6	-	-
7	-	-
8	-	-

Channel A			Channel B			
Error	Time [s]	Range	Error	Time [s]	Range	
0	2009E365 Safe process data set	1524225	SP error	902201 Encoder signal monitoring error	1603573	Encoder
1	2009E365 Safe process data set	1520613	SP error	902201 Encoder signal monitoring error	1548320	Encoder
2	2009E365 Safe process data set	1499682	SP error	902201 Encoder signal monitoring error	1548311	Encoder
3	2009E365 Safe process data set	1498112	SP error	902201 Encoder signal monitoring error	1548282	Encoder
4	2009E365 Safe process data set	1497403	SP error	902201 Encoder signal monitoring error	1524207	Encoder
5	2009E365 Safe process data set	1497391	SP error	902201 Encoder signal monitoring error	1520607	Encoder
6	2009E365 Safe process data set	1497381	SP error	2009E365 Safe process data set	1499682	SP error
7	932206 Faulty track signals	1497370	Encoder	2009E365 Safe process data set	1498112	SP error
8	2009E365 Safe process data set	1496344	SP error	326719 HW diagnostics DO internal error	1498102	F-DO error
9	-	-	-	326719 HW diagnostics DO internal error	1498076	F-DO error
10	-	-	-	326719 HW diagnostics DO internal error	1498069	F-DO error
11	-	-	-	2009E365 Safe process data set	1497403	SP error
12	-	-	-	2009E365 Safe process data set	1497391	SP error
13	-	-	-	2009E365 Safe process data set	1497381	SP error
14	-	-	-	902201 Encoder signal monitoring error	1497347	Encoder
15	-	-	-	902201 Encoder signal monitoring error	1496980	Encoder

8773153803

- **Current errors (error list)**

The "current errors" list is a chronological error history. The first error is displayed in line 0. Subsequent errors are entered in the lines below that without regard for priorities. Identical error codes are not entered more than once. When there are more than 10 errors with different error codes, only the error code in line 9 is overwritten (no circular buffer).

If no non-acknowledgeable errors are pending, the current error list is deleted completely with an error acknowledgement. With a 24 V reset, the list is deleted irrespective of the acknowledgeability of the listed errors. The error list helps you to analyze details when several error messages are interconnected.

- **Fault memory**

All initial errors (i.e. error that occur after switching on the S12 safety option or that occur again after acknowledging an error) are stored remanently with the corresponding time stamp. Directly inherited errors that occur before an error acknowledgement or 24 V reset are stored in the error memory only if they have a higher display priority.

To the left of the [Reset error memory] button, the current value of the operating hours counter of the S12 safety option is shown in seconds.

The error memory can only be deleted by clicking the [Reset error memory] button. The entries remain in the memory after an error acknowledgement, a 24 V reset or a parameter download.

In line 0 of the list, the most recent initial or inherited error is shown. The list is a circular buffer. If there are more than 32 entries, the oldest error is overwritten.

- **Structure of the error codes**

The error list entries consist of the error code ID (hex value) and the collective error designation (see chapter "Error table of the S12 safety option" (→ 146)).

12.6 Device replacement

Observe the following information:

INFORMATION



- Only components marked with the FS logo for functional safety may be installed in safety applications. For combinations of devices without FS logo (consisting of individual EBOX and ABOX), the safety function must be described in the documentation.
- A faulty S12 safety option must be put out of operation within the next 100 hours.

For device replacement, a MOVIFIT® in the system/application is replaced by an identical device. The replacement device must not necessarily be a new device. The safety parameter set is stored locally in the ABOX. This is why the ABOX should only be replaced if absolutely necessary. When replacing the ABOX, the overall device must be validated again. When the EBOX is replaced an automatic data acceptance from the ABOX memory is only supported in fieldbus operation. In this case, you do not have to validate the safety functions. In independent operation, the safety functions must be re-parameterized and re-validated.

After a device replacement, the functionality of the application should be restored without user interaction. The possible device replacement scenarios and corresponding measures are described in the chapters below.

Adjust the verification documentation accordingly after the device replacement.

When replacing a MOVIFIT® device, a difference is made between the following variants.

12.6.1 Data backup

Before MOVIFIT® with S12 safety option is replaced create a data backup. Proceed as follows:

- Save the data of the standard components (control board, power section, application module) via the engineering software MOVITOOLS® MotionStudio depending on the MOVIFIT® design.
- Save the data of the safety parameter set (S12 parameterization) via the parameterization tool Assist S12.
- The safety parameter set must not be saved in fieldbus operation.

12.6.2 Device replacement depending on the operating mode

In general the replacement behavior of the device components differs depending on the operating mode:

- Fieldbus operation/PROFIsafe

In fieldbus operation, the EBOX can be replaced without any further user intervention.

- Independent operation

In independent operation, parameter verification and overall validation become necessary after a device replacement.

The user must not disassemble the MOVIFIT® EBOX.

The following replacement scenarios are supported for the EBOX:

Initial situation	Response of the S12 safety option	Necessary measure
Fieldbus operation is activated in the safety parameter set.	Device starts as usual.	None.
Safety parameter set or hardware is incompatible with the new S12 safety option.	Device fault.	Re-parameterization and verification A password set earlier for this item (ABOX) is reset to the default setting.
Fieldbus operation is deactivated in the safety parameter set (independent operation).	Device fault.	
The ABOX is new or has never been operated together with the S12 safety option. The new EBOX contains the default safety parameter set (e.g. brand-new).	The device starts with the verified default safety parameter settings.	If operation with default parameter settings is desired: Enter the default iPar CRC value in the F controller (overall validation necessary). Otherwise re-parameterization, verification, and overall validation.

An overall validation of the safety functions after replacing the EBOX is not necessary if the iPar CRC value of the safety parameter set remains unchanged after re-parameterization. This can be proven by comparing the iPar CRC value with the existing acceptance protocol.

After replacing the EBOX, make sure to enter the new serial number of the EBOX in the existing acceptance protocol of the complete device.

12.6.3 EBOX device replacement

Open



▲ WARNING

Electric shock due to dangerous voltages in the ABOX.

Severe or fatal injuries.

- De-energize the new MOVIFIT® device. Observe the minimum switch-off time after disconnection from the supply system:
 - **1 minute**

When opening the device, adhere also to the safety notes in the "MOVIFIT® .." operating instructions. > Chapter "Central opening/closing mechanism".

1. Turn the central retaining screw in counterclockwise direction using a socket wrench (SW8).

2. Remove the EBOX from the ABOX.
3. Check the type designation on the nameplate of the new EBOX.
 - ⇒ In case of safety-related applications the EBOX may only be replaced by a new EBOX [2] with the same type designation as listed as EBOX type designation on the entire MOVIFIT® device [1].

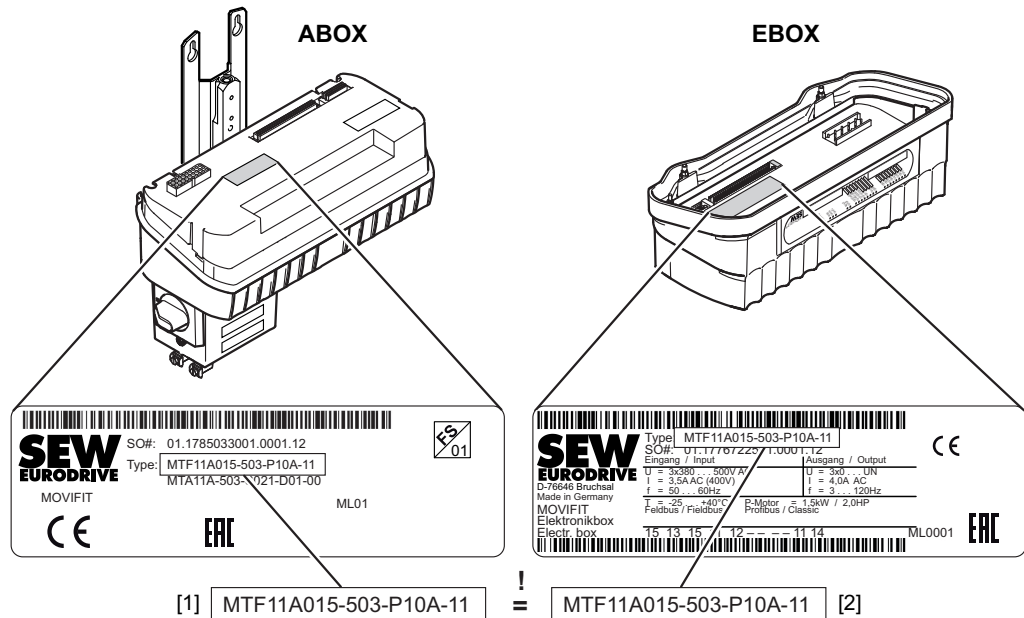

- ⇒ This ensures the FS 80 functionality after device replacement.

Closing

When closing the device, adhere also to the information in the "MOVIFIT® .." operating instructions. > Chapter "Central opening/closing mechanism" > "Closing".

1. Position the new EBOX on the ABOX.
2. Turn the retaining screw in clockwise direction (tightening torque max. 7 Nm).
3. Supply the MOVIFIT® device with voltage.

Startup with replaced EBOX

S12 in autonomous operation

1. Download, verify and approve the S12 parameterization (data backup) via "Assist S12". The verification is complete when the device is restarted.
2. Save the data of the standard component (control board and power section, application module) using the engineering software MOVITOOLS® MotionStudio.
3. Validation of the S12 parameterization

After a brief function test the approved parameterization can be performed by comparing the iPar CRC value old/new. When this is not possible, a complete verification is required.

S12 in fieldbus operation

1. The S12 parameterization is transferred to the S12 safety option from the ABOX memory after the EBOX replacement. After the iPar CRC values were compared by the higher-level safety controller, the S12 parameterization is enabled. The S12 safety option then has the status "Approved". This is displayed at the device via the LED F state = green, or in the parameterization tool Assist as "RUN with approval". The S12 parameterization must not necessarily be downloaded.
2. Save the data of the standard component (control board and power section, application module) using the engineering software MOVITOOLS® MotionStudio.
3. A further validation is not required.

12.6.4 Device replacement of ABOX with/without EBOX

The following replacement scenarios are supported for the ABOX or the complete device:

Initial situation	Response of the S12 safety option	Necessary measure
Complete device is prepared (parameterized and verified).	Device starts.	Validating the wiring.
Complete device (brand-new).	Device starts, if iPar CRC value has been registered in the controller.	Re-parameterization, verification, and overall validation.
Replacing the ABOX (Parameterization of the replacement device or the replacement ABOX unknown).	Possible device error.	Re-parameterization, verification, overall validation.

INFORMATION



If the iPar CRC value of the safety parameter settings remains the same after re-parameterization (comparison of acceptance protocol with previous protocol), you only have to validate the wiring after replacing the ABOX or the complete device.

Replacing individual circuit boards in the ABOX is not permitted.

Startup of the replaced ABOX or of the entire device

1. Download, verify and approve the S12 parameterization (data backup) via the parameterization tool "Assist S12".
2. Save the data of the standard component (control board, power section, application module) using MOVITOOLS® MotionStudio.
3. Validation of the S12 parameterization
After a brief function and wiring test, the approved parameterization can be performed via comparison of the iPar CRC values new/old. When this is not possible, a complete verification is required.

12.7 Error table of the S12 safety option

Reading the errors from the error memory

The errors codes in the fault memory of the Assist S12 are displayed hexadecimally with 6 or 8 digits and a short text depicting the device status.

To find the entries in the following table, only the first 2 digits (for 6-digit error codes) or the first 4 digits (for 8-digit error codes) are relevant:

Fault memory 806400s		
Channel A		
	Error	Time [s]
10	74B08 SDI0 fault: CCW direction of rotation	493354

0074		SDI0/1/2/3 error: Counterclockwise direction of rotation
0075		
0076		
0077		

12105325707

Error table

Code	Meaning	Response	Possible cause	Measure
0002	Internal system error.	<ul style="list-style-type: none"> Display Switching off the F-DO outputs Safe status of option (depending on parameterization) 	Internal system error.	<ul style="list-style-type: none"> Acknowledge error, switch device off and on again, if necessary. If this error occurs repeatedly, replace the EBOX or contact SEW-EURODRIVE Service.
0004	DSO supply voltage error.	Safe status of option.	Fault detected in the over-voltage protection of the S12 safety option (supply voltage exceeds the permitted range, hardware fault n protection circuit detected).	<ul style="list-style-type: none"> Check 24 V voltage supply at terminal 24V_O (permitted voltage range, voltage peaks, voltage dips). If this error occurs repeatedly, replace the EBOX or contact SEW-EURODRIVE Service.
0008	Ext memory DSO error.	Warning or safe status of option.	EEPROM data error.	<ul style="list-style-type: none"> Acknowledge error, check parameterization (re-parameterize, if necessary). If this error occurs repeatedly, replace the EBOX or contact SEW-EURODRIVE Service.
0014	HW diagnostics: DI internal error.	Parameterizable F-DI error response.	Error detected in internal evaluation of safety-related F-DI inputs.	<ul style="list-style-type: none"> Acknowledge error. If this error occurs repeatedly, replace the EBOX or contact SEW-EURODRIVE Service.

22865268/EN – 06/2016

Code	Meaning	Response	Possible cause	Measure
0016	Discrepancy error F-DI00 – F-DI01	Parameterizable F-DI error response.	<ul style="list-style-type: none"> Parameterizable discrepancy time in 2-channel evaluation of safety-related F-DI inputs exceeded/error in sub-channel. Switch test conditions not fulfilled. 	<ul style="list-style-type: none"> Check the connected 2-channel switch/sensor at the safety-related input pair F-DI 0/1 (2/3, 4/5, 6/7) or increase the parameter <i>F-DI 0/1 (2/3, 4/5, 6/7) discrepancy time</i>. When the function <i>F-DI 0/1 (2/3, 4/5, 6/7) switch test</i> is activated, the switch test condition must be fulfilled before the error can be acknowledged.
0018	Discrepancy error F-DI02 – F-DI03			
001A	Discrepancy error F-DI04 – F-DI05			
001C	Discrepancy error F-DI06 – F-DI07			
0020	Crossfault F-DI00	Parameterizable F-DI error response.	Crossfault detected at safety-related F-DI input.	Check external wiring/connection of safety-related F-DI input for crossfaults.
0021	Crossfault F-DI01			
0022	Crossfault F-DI02			
0023	Crossfault F-DI03			
0024	Crossfault F-DI04			
0025	Crossfault F-DI05			
0026	Crossfault F-DI06			
0027	Crossfault F-DI07			
0028	Wiring fault F-DI00	Parameterizable F-DI error response.	No stable input signal within the parameterized input filter time at safety-related F-DI input.	Check the switch/sensor connected to the safety-related F-DI input. Increase the <i>F-DI input filter time</i> parameter.
0029	Wiring fault F-DI01			
002A	Wiring fault F-DI02			
002B	Wiring fault F-DI03			
002C	Wiring fault F-DI04			
002D	Wiring fault F-DI05			
002E	Wiring fault F-DI06			
002F	Wiring fault F-DI07			

Code	Meaning	Response	Possible cause	Measure
0032	HW diagnostics: DO internal error	Safe state of option or parameterizable F-DO error response.	Error detected in internal hardware of safety-related F-DO outputs.	<ul style="list-style-type: none"> Acknowledge error. If this error occurs repeatedly, replace the EBOX or contact SEW-EURODRIVE Service.
0034	F-DO overcurrent error	Safe status of option	The safety-related F-DO outputs are overloaded in total.	Reduce the sum of the current load at the safety-related F-DO outputs.
0035	DO_STO error: Crossfault	Parameterizable F-DO error response.	Error in internal hardware of the safety-related F-DO_STO output (internal crossfault).	<ul style="list-style-type: none"> Acknowledge error. If this error occurs repeatedly, replace the EBOX or contact SEW-EURODRIVE Service.
0036	DO_STO error: Overcurrent		Current load at safety-related F-DO_STO output is too high.	Reduce the current load at safety-related F-DO_STO output.
0037	DO_STO error: Overvoltage		Crossfault detected at safety-related F-DO_STO output.	Check external connection of safety-related F-DO_STO output for crossfaults.
0038	DO_STO error: Internal measuring error	Safe state of option or parameterizable F-DO error response.	Error in internal hardware of the safety-related F-DO_STO output (internal measuring error).	<ul style="list-style-type: none"> Acknowledge error. If this error occurs repeatedly, replace the EBOX or contact SEW-EURODRIVE Service.
0039	DO00 error: Crossfault	Parameterizable F-DO error response.	Error in internal hardware of the safety-related F-DO00 output (internal crossfault).	
003A	DO00 error: Overcurrent		Current load at safety-related F-DO00 output is too high.	Reduce the current load at safety-related F-DO00 output.
003B	DO00 error: Overvoltage		Crossfault detected at safety-related F-DO00 output.	Check external connection of safety-related F-DO00 output for crossfaults.
003C	DO00 error: Internal measuring error	Safe state of option or parameterizable F-DO error response	Error in internal hardware of the safety-related F-DO00 output (internal measuring error).	<ul style="list-style-type: none"> Acknowledge error. If this error occurs repeatedly, replace the EBOX or contact SEW-EURODRIVE Service.
003D	DO01 error: Crossfault	Parameterizable F-DO error response.	Error in internal hardware of the safety-related F-DO01 output (internal crossfault).	<ul style="list-style-type: none"> Acknowledge error If this error occurs repeatedly, replace the EBOX or contact SEW-EURODRIVE Service.
003E	DO01 error: Overcurrent		Current load at safety-related F-DO01 output is too high.	Reduce the current load at safety-related F-DO01 output.
003F	DO01 error: Overvoltage		Crossfault detected at safety-related F-DO01 output.	Check external connection of safety-related F-DO01 output for crossfaults.
0040	DO01 error: Internal measuring error	Safe state of option or parameterizable F-DO error response.	Error in internal hardware of the safety-related F-DO01 output (internal measuring error).	<ul style="list-style-type: none"> Acknowledge error If this error occurs repeatedly, replace the EBOX or contact SEW-EURODRIVE Service.

Code	Meaning	Response	Possible cause	Measure
0041	DO_STO error: Wire break	Parameterizable F-DO error re- sponse.	Minimum current not reached with active F- DO_STO output.	Check external connection of safety-related F-DO_STO output for wire break/interruption.
0042	DO00 error: Wire break		Minimum current not reached with active F-DO00 output.	Check external connection of safety-related F-DO00 output for wire break/interruption.
0043	DO01 error: Wire break		Minimum current not reached with active F-DO01 output.	Check external connection of safety-related F-DO01 output for wire break/interruption.
0050	SLS0/1/2/3: n _{max} exceeded	STO/SS1 (de- pending on parameteriza- tion).	The parameterized limit value <i>Max. motor speed</i> with selected SLS0/1/2/3 function or within the parameterized monitoring delay of SLS0 is exceeded.	<ul style="list-style-type: none"> • Check application. • Increase the <i>Max. motor speed</i> parameter.
0051				
0052				
0053				
0054	SLS0/1/2/3: n _{sis} exceeded		Parameterized SLS speed ramp exceeded while decel- erating the drive to the SLS0/1/2/3/ limit speed.	<ul style="list-style-type: none"> • Check application/startup. • Extend the SLS parameter <i>ramp time</i>. • Increase the SLS parameter <i>ramp monitoring delay</i>. • Increase the SLS parameter <i>difference to ramp</i>.
0055				
0056				
0057				
0058	SLS0/1/2/3: n _{sis_r} exceeded		Parameterized SLS0/1/2/3 limit speed <i>positive limit speed</i> exceeded.	<ul style="list-style-type: none"> • Check application/startup. • Increase the SLS0/1/2/3 para- meter <i>difference to limit speed</i>. • Increase the SLS parameter <i>speed filter</i>.
0059				
005A				
005B				
005C	SLS0/1/2/3: n _{sis_l} exceeded	STO/SS1 (de- pending on parameteriza- tion).	Parameterized SLS0/1/2/3 limit speed <i>negative limit speed</i> exceeded.	
005D				
005E				
005F				
0060	n _{sis0} in opposite direction ex- ceeded		Parameterized SLS0/1/2/3 limit speed in opposite direc- tion exceeded while drive is decelerating.	<ul style="list-style-type: none"> • Check application/startup. • Extend the SLS parameter <i>ramp time</i>.
0061	n _{sis1} in opposite direction ex- ceeded			
0062	n _{sis2} in opposite direction ex- ceeded			
0063	n _{sis3} in opposite direction ex- ceeded			

Code	Meaning	Response	Possible cause	Measure
0064	SS1A: n_{\max} exceeded	STO	The parameterized limit value <i>Max. motor speed</i> with selected SS1(a) function or within the parameterized monitoring delay of SS1(a) is exceeded.	<ul style="list-style-type: none"> • Check application. • Increase the <i>Max. motor speed</i> parameter.
0065	SS1A: n_{\max} in ramp exceeded		Parameterized SS1(a) speed ramp exceeded while decelerating the drive to speed 0.	<ul style="list-style-type: none"> • Check application/startup. • Extend the parameter <i>SS1a ramp time</i>. • Increase the parameter <i>SS1a ramp monitoring delay</i>. • Increase the parameter <i>SS1a distance to ramp</i>.
0066	SS1A: n_{\min} at standstill exceeded		After reaching standstill (i.e. speed below parameterized minimum speed <i>minimum motor speed</i>), the minimum speed was exceeded again.	<ul style="list-style-type: none"> • Check application. • Increase the <i>Min. motor speed</i> parameter. • Use a brakemotor / check brake wear.
0067	STO: Disconnection by-passed	(STO)	MOVIFIT® FC variant: After disconnecting the F-DO_STO output, communication with the inverter is still detected (monitoring is not safety-related)	Check connection/wiring of power section to safety-related F-DO_STO output (safe disconnection of power section).
0068	STO: Coasting time exceeded	STO	Parameterized STO limit value <i>permitted coasting time</i> (time from activation of STO until detection of standstill) exceeded.	<ul style="list-style-type: none"> • Check application / brake wear. • Increase the STO parameter <i>permitted coasting time</i>.
0070	SDI0/1/2/3 error: CW direction of rotation	STO	Movement detected in the positive direction that is blocked by SDI0/1/2/3.	<ul style="list-style-type: none"> • Check application. • Increase the SLS parameter <i>SDI tolerance</i>.
0071				
0072				
0073				
0074	SDI0/1/2/3 error: CCW direction of rotation	STO	Movement detected in the negative direction that is blocked by SDI0/1/2/3.	<ul style="list-style-type: none"> • Check application. • Increase the SLS parameter <i>SDI tolerance</i>.
0075				
0076				
0077				

Code	Meaning	Response	Possible cause	Measure
0080	Parameter setting not plausible	Safe state of S12	The current parameter setting contains parameter values outside the permitted value range and/or not permissible combinations of parameter values.	Correct the parameter settings according to the notes in the "Assist S12" parameterization tool and download the parameter settings again.
0081	Parameter setting corrupt		The safety parameter set is corrupt and cannot be used.	Re-parameterize the device.
0082	Parameter setting not compatible		The safety parameter set is not compatible with the current device firmware.	
0083	Device replacement error		A device was replaced, and PROFIsafe mode is deactivated in the local parameter set (ABOX). In this case, the local parameter set cannot be transferred.	
0084	S12 parameter set missing in ABOX		There is no safety parameter set stored in the local memory (ABOX).	
0085	Error when storing data in the ABOX	STO	An error occurred when storing the safety parameter set in the local memory (ABOX).	<ul style="list-style-type: none"> Switch device off and on again. Check the parameter settings, re-parameterize, if necessary. If this error occurs repeatedly, replace the EBOX/ABOX or contact SEW-EURODRIVE Service.
0086	Internal parameter set corrupt	Warning	The safety parameter set in the internal memory (EBOX) is corrupt and cannot be used.	<ul style="list-style-type: none"> Re-parameterize the device If this error occurs repeatedly, replace the EBOX or contact SEW-EURODRIVE Service.
0087	Internal error between S12 and control board	Safe state of S12	Internal communication error.	<ul style="list-style-type: none"> Switch device off and on again. If this error occurs repeatedly, replace the EBOX or contact SEW-EURODRIVE Service.
0088	Error saving verification	No transition to RUN/STO set	An error occurred when storing the safety parameter set in the local memory.	<ul style="list-style-type: none"> Switch the device off and on again. Verify the parameter settings (repeat validation, if necessary). If this error occurs repeatedly, replace the EBOX/ABOX or contact SEW-EURODRIVE Service.

Code	Meaning	Response	Possible cause	Measure
0090	Encoder signal monitoring error	STO	Non-equivalence error in the encoder track signals or encoder in error state.	<ul style="list-style-type: none"> Check the encoder track signal lines. Replace encoder, if necessary.
0091	Encoder level monitoring error		Error in the level monitoring function for the encoder track signals.	<ul style="list-style-type: none"> Check the encoder track signal lines. Replace encoder, if necessary.
0092	Error limit speed		The encoder detected a speed that exceeds the maximally evaluable value of 3800 rpm.	Check the parameterization of inverter/application.
0093	Faulty track signals		Interference in the encoder track signals.	<ul style="list-style-type: none"> Check encoder cable and connection. Check ground connection and shielding.
1040	Ambient temperature too high	Safe status of option	The temperature sensor for the EBOX electronics reports that the max. permitted temperature is exceeded.	<p>Improve the cooling of the EBOX. Reduce the load on the safety-related F-DO outputs.</p> <p>MOVIFIT® FC variant: Reduce the motor load / PWM frequency of the inverter.</p>
1041	Ambient temperature too low		The temperature sensor for the EBOX electronics reports that the min. permitted temperature is undercut.	Increase the ambient temperature.
1042	Supply voltage too high	All F-DOS switched off	Voltage supply (24V_O) too high.	Check 24 V voltage supply at terminal 24V_O.
1043	Supply voltage too low		Voltage supply (24V_O) too low.	

Code	Meaning	Response	Possible cause	Measure
2000	DSO status error when receiving FPAR	Warning	Safety protocol error: Set-Prm process - DSO not in a valid state.	Disconnect/connect communication.
2001	Error applying FPAR to DSO	Safe status of option	Safety protocol error: Set-Prm process – transfer of FPar failed.	
2002	Faulty process data length	Warning or safe status of option	Safety protocol error: Check configuration process – faulty process data length of PO/PI data.	
2003	CRC2 configuration error	Safe status of option	Safety protocol error: Check configuration process – configuration in SPD failed, invalid CRC length.	
2004	Error in configuration process		Safety protocol error: Check configuration process – invalid return when configuring SPD.	
2005	DSO status when receiving CheckCfg	Warning	Safety protocol error: Set-Prm check configuration process	PowerOFF/powerON S12
2006	Error in SPD	Warning or safe status of option	Safety protocol error: Check configuration process – faulty process data length of PO/PI data	
2007	Communication error	Warning	Safety protocol error: Cyclic data exchange error.	
2008	Timeout safety protocol	Warning	Safety protocol error: Cyclic data exchange error, timeout detected.	
2009	Safe process data set		Safety protocol error: Cyclic data exchange error, process data in safe state	
200A	SP zero message received		Safety protocol error: Cyclic data exchange error, zero telegram was received.	

Code	Meaning	Response	Possible cause	Measure
8040	Mismatch of F_Dest_Add	Safe status of option	F parameterization error: Mismatch of safety destination address.	Check F parameters in the configuration tool of the safe fieldbus master.
8041	F_Dest_Add not valid		F parameterization error: Safety destination address not valid.	
8042	F_Source_Add not valid		F parameterization error: Safety source address not valid.	
8043	F_WD_Time is 0 ms		F parameterization error: Safety watchdog Time value is 0 ms.	
8044	F_SIL exceeds SIL f. application		F parameterization error: Parameter F_SIL exceeds.	
8045	F_CRC_Length does not match		F parameterization error: Parameter F_CRC_Length not valid.	
8046	F parameter set incorrectly		F parameterization error: Version of F Parameter Set incorrect.	
8047	Inconsistent FPar CRC1 error		F parameterization error: Data inconsistent in received F parameter block.	
8048	Device information, see manual		F parameterization error: Device-specific diagnostics.	
8049	Save iParameter WDT exceeded		F parameterization error: Save iParameter watchdog time exceeded.	
804A	Restore iParameter WDT exceeded		F parameterization error: Restore iParameter watchdog time exceeded.	
804B	Inconsistent iParameter iParCRC		F parameterization error: Inconsistent IParameters (iParError).	
804C	F_Block_ID not supported		F parameterization error: F_BlockID not supported.	
804D	Transmission error: CRC2 error		F parameterization error: Transmission error: data inconsistent.	
804E	Transmission error: WDT elapsed		F parameterization error: Transmission error: timeout.	
804F	Reserved for further use		F parameterization error: Reserved do not use numbers, do not evaluate numbers.	

13 Parameter description

13.1 General information

13.1.1 10122.7 IO error effects

The drop-down list contains the following options:

- Entire assembly:
The entire safety option goes to a safe state.
- Channel-wise, (F-DI), block-wise, (F-DO):
F-DI: When an error is pending at an F-DI, only the F-DI that is affected by the error goes to a safe state.
F-DO: When an error is pending at an F-DO, all the other F-DOs go to a safe state as well.
- Channel-wise, (F-DI, F-DO)
F-DI: When an error is pending at an F-DI, only the F-DI that is affected by the error goes to a safe state.
F-DO: When an error is pending at an F-DO, only the F-DO that is affected by the error goes to a safe state.

13.1.2 10122.10 PROFIsafe fieldbus

The drop-down list contains the following options:

- Available:
The S12 safety option supports the PROFIsafe protocol.
- Not available:
The S12 safety option is used independently.

13.1.3 10122.2 Encoder type

The drop-down list contains the following options:

- Not available:
No encoder evaluation and monitoring. Speed-related safety functions cannot be parameterized.
- EI7C FS:
The connected EI7C built-in encoder is evaluated and the speed-related safety functions can be executed with the determined speed information (only available with MOVIFIT® FC variant).

13.1.4 10122.8 Maximum motor speed (n1)

Unit: rpm

Value range:

- 60 – **3800**

The maximum motor speed (n1) is the limit speed that is tolerated when the speed-related safety functions are selected. If the motor speed is above the parameterized maximum motor speed when these safety-functions are selected, an error is tripped.

If the drive exceeds a speed of 3800 rpm, an error is tripped irrespective of the selected function when operation with speed sensor is parameterized.

13.1.5 10122.9 Minimum motor speed (n2)

Unit: rpm

Value range:

- **60** – 200

The minimum motor speed (n2) is the speed below which speed monitoring is no longer active.

An exceedance of the parameterized speed limit can only be detected above the minimum speed. A speed below the minimum speed is interpreted by the S12 safety option as standstill.

13.2 F-DI

13.2.1 Safety-related digital inputs

10123.2 – 10123.5 Connection type

The drop-down list contains the following options:

- 1-channel:

The corresponding F-DIs are evaluated independently of each other.

- 2-channel equivalent:

The input levels are processed in pairs. If the input levels are not equal, the process value of the F-DI pair goes to a safe state. After the parameterized discrepancy time has elapsed, an error message is generated and the process value is kept in a safe state until the error is acknowledged.

With equivalent input levels, the process value follows the input level of the input channel with an even channel number.

- 2-channel non-equivalent:

The input levels are processed in pairs. If the input levels are equal, the process value of the F-DI pair goes to a safe state. After the parameterized discrepancy time has elapsed, an error message is generated and the process value is kept in a safe state until the error is acknowledged.

With non-equivalent input levels, the process image follows the input level of the input channel with an even channel number.

10123.10 – 10123.17 Input filter time (t1)

Unit: ms

Value range: 4 – **10** – 250

Description: The input signal goes through a parameterizable filter to eliminate contact bouncing and interference. Bounces that are shorter than the set filter time are ignored.

10123.6 – 10123.9 Discrepance time (t2)

Unit: ms

Value range: 25 – **500** – 5000

The discrepancy time (t2) is the tolerated time in which the F-DIs of an F-DI pair that is parameterized for 2-channel mode may have a discrepancy in the input level (equivalent: both different, non-equivalent: both identical) before an error is tripped.

13.2.2 Diagnostics**10123.18 F-DI pulsed sensor supply**

The drop-down list contains the following options:

- Active:
Pulsed sensor supply for F-SS0 and F-SS1 is active. Activated pulsed sensor supply is a prerequisite for the activation of crossfault monitoring.
- Not active:
Pulsed sensor supply for F-SS0 and F-SS1 is not active.
A constant 24 V supply is output at F-SS0 and F-SS1.

10123.19 –10123.26 Crossfault monitoring

The drop-down list contains the following options:

- Active:
Crossfault monitoring is active. Faults in the sensor wiring can be detected.
- Not active:
Crossfault monitoring is not active.

10123.28 –10123.30 F-DI. switch test

The drop-down list contains the following options:

- Active:
The switch test function for 2-channel evaluation is active. When the switch test function is active, a discrepancy error is only acknowledged if the input levels meet the switch test conditions.
 - Equivalent:
Both F-DI input levels are LOW.
 - Non-equivalent:
Even-numbered F-DI input level is LOW and uneven-numbered F-DI input level is HIGH.
- Not active:
The switch test function for 2-channel evaluation is not active.

13.3 F-DO

13.3.1 10124.6 F-DO-STO line diagnostics

The drop-down list contains the following options:

- Not active:

The line diagnostics function is not active.

- Active:

The line diagnostics function is active.

13.3.2 10124.9 F-DO-STO test duration (t1)

Unit: μs

Value range: 250 – **1000** – 5000

Description: Maximum test pulse duration for the F-DO STO switch tests

13.3.3 10124.12 F-DO-STO wire break monitoring

The drop-down list contains the following options:

- Not active:

The wire break monitoring function is not active.

- Active:

The wire break monitoring function is active.

13.3.4 10124.2, 10124.3 F-DO0/1 connection type

The drop-down list contains the following options:

- 2-pole sourcing/sinking:

The load is connected between F-DO0/1_P and F-DO0/1_M.

- 1-pole sourcing:

The load is connected between F-DO0/1_P and 0V24_O.

13.3.5 10124.4, 10124.5 F-DO0/1 line diagnostics

The drop-down list contains the following options:

- Not active:

The line diagnostics function is not active.

- Active:

The line diagnostics function is active.

13.3.6 10124.7, 10124.8 F-DO0/1 test duration (t2, t3)

Unit: μs

Value range: 250 – **1000** – 5000

Description: Maximum test pulse duration for the F-DO0/1 switch tests

13.3.7 10124.10, 10124.11 F-DO0/1 wire break monitoring

The drop-down list contains the following options:

- Not active:
The wire break monitoring function is not active.
- Active:
The wire break monitoring function is active.

13.4 STO

13.4.1 10125.3 STO delay (t1)

Unit: ms

Value range: 0 – 1000

The STO delay (t1) is the time delay between tripping the "STO selected" safety function and switching off F-DO_STO, and other F-DO outputs parameterized to STO, if applicable.

Only for S12A safety option.

13.4.2 10125.2 STO status display delay (t2)

Unit: ms

Value range: 0 – 40 – 500

The STO status display delay (t2) is the delay time after which the status of the STO function is shown as active at the earliest after switching off the F-DO_STO output. This applies to the STO status both in the safe process input data and in internal processing.

This parameter should be set to the time that the actuator (e.g. inverter) needs to go to a safe state (e.g. STO) after switching off the safety-related F-DO_STO output. (Response time of actuator with respect to STO).

13.4.3 10125.4 Permitted coasting time (t3)

Unit: ms

Value range: 0 – 65535

The coasting time is defined as the time between selecting the STO safety function and the standstill of the drive. The coasting time can be measured and monitored with respect to exceeding the parameterized limit value. If the test mode is active, exceeding the limit value *Permitted coasting time* trips an error and maintains the STO status until the error is acknowledged. An encoder must be parameterized to use this function. Coasting measurement is only active when a value \neq "0" is parameterized.

13.5 SS1

13.5.1 10126.2 Function

The drop-down list contains the following options:

- Inhibited:
No SS1 safety function can be selected.

- SS1a enabled:
Variant a of the SS1 safety function can be selected.
- SS1c enabled:
Variant c of the SS1 safety function can be selected.

13.5.2 10126.3 SS1c delay (t1)

Unit: ms

Value range: 10 – **1000** – 10000

The SS1c delay time (t1) is the time between the selection of the safety function and the activation of the STO function.

13.5.3 10126.6 SS1a ramp monitoring delay (t2)

Unit: ms

Range of values: 10 – **500** – 1000

The SS1a ramp monitoring delay (t2) is the time between the selection of the SS1(a) function and the start of monitoring of the speed deceleration ramp. (The stop command is sent to the inverter immediately when the function is selected). During the delay time, adherence to the maximum motor speed (n1) is monitored. This time is necessary to compensate for the transmission delay to the inverter.

13.5.4 10126.5 SS1a ramp time (t3)

Unit: ms

Value range: 10 – **1000** – 10000

The ramp time (t3) is the ramp time for the monitored speed limit curve in the safety option and the limit of the speed deceleration ramp in the inverter.

The ramp time refers to a speed change of 1500 rpm.

13.5.5 10126.7 SS1a distance to ramp (n1)

Unit: 1/min

Range of values: 0 – **100** – 1000

SS1 distance to ramp (n1) is the tolerance speed that is added to the current value of the motor speed when the function is selected. This determines the initial value of the monitored speed limit curve.

13.5.6 10126.4 SS1a STO function selection delay (t4)

Unit: ms

Value range: 10 – **250** – 1000

If the motor speed decreases faster than specified by the SS1(a) ramp time, STO is also activated earlier, when the motor speed falls below the minimum motor speed (n2) for at least the time specified in SS1(a) function selection delay. The parameterized time prevents the early activation of STO when the speed only briefly falls below the minimum speed.

13.6 SLS 0, 1, 2, 3**13.6.1 10128.2 – 10131.2 Function**

The drop-down list contains the following options:

- Enabled:
SLS function can be selected.
- Inhibited:
The SLS function cannot be executed.

13.6.2 10128.3 – 10131.3 Limit speed, positive (n1)

Unit: rpm

Value range: 60 – **3800**

The positive limit speed (n1) is the speed limit value in the positive direction of rotation when the corresponding SLS function has been activated by the safety option.

13.6.3 10128.4 – 10131.4 Limit speed, negative (n1)

Unit: rpm

Value range: 60 – **3800**

The negative limit speed (n2) is the speed limit value in the negative direction of rotation when the corresponding SLS function has been activated by the safety option.

13.6.4 10128.5 – 10131.5 Distance to limit speed (n3)

Unit: rpm

Value range: 0 – **100** – 1000

The distance to the limit speed (n3) is the tolerance between the SLS speed limit value n1/n2 monitored by the safety option via an encoder and the speed setpoint limit values that are active in the inverter.

13.6.5 10128.6 – 10131.6 SDI function

The drop-down list contains the following options:

- deactivated:
The direction of rotation is not monitored.
- Positive/negative direction permitted:
The positive/negative direction of rotation is monitored. Movement that exceeds the permitted tolerance (see 10127.7) into the blocked (not permitted) direction trips an error with STO error response.

13.7 SLS (general)**13.7.1 10127.4 Ramp monitoring delay (t1)**

Unit: ms

Value range: 10 – **500** – 1000

The ramp monitoring delay (t_1) is the time between the selection of the SLS function and the start of monitoring of the speed deceleration ramp. (The speed limitation is sent to the inverter immediately when the function is selected). During the delay time, adherence to the maximum motor speed (n_1) is monitored.

This time is necessary to compensate for the transmission delay to the inverter.

13.7.2 10127.2 Ramp time (t_2)

Unit: ms

Value range: 10 – **1000** – 10000

The ramp time (t_2) is the ramp time for the monitored speed limit curve in the S12 safety option and the limit of the speed deceleration ramp in the inverter.

The ramp time refers to a speed change of 1500 rpm.

13.7.3 10127.3 Distance to ramp (n_4)

Unit: rpm

Value range: 0 – **100** – 1000

The distance to the ramp (n_4) is the tolerance speed that is added to the current value of the motor speed when the function is selected. This determines the initial value of the monitored speed limit curve for monitoring the deceleration to the SLS speed limit values.

13.7.4 10127.5 Error response to overspeed

The error response to exceeding the monitored speed limit curve can be parameterized with the SLS function. The error response applies to all SLS function blocks. (The STO error response always applies to the SDI sub-function).

The drop-down list contains the following options:

- STO:

The STO function is activated when the speed monitoring function trips.

(When STO is activated as an error response to SLS; the safety-related outputs are deactivated immediately. There is no deactivation delay by the parameterized *STO delay (t_1)* time.)

- SS1:

The SS1 function is activated when the speed monitoring function trips. This is the SS1 variant that was parameterized for the SS1 function.

13.7.5 10127.6 Speed filter

Unit: Degree

Value range: **0** – 1000

The value of the speed filter is the tolerated limit value for a brief exceedance of the parameterized SLS speed limit values. Physically, the filter limit value corresponds to a tolerated angle of rotation. Filtering is not active yet while the drive is decelerating to the parameterized SLS speed limit values.

13.7.6 10127.7 SDI tolerance

Unit: Degree

Value range: 0 – 3600

The parameter specifies the maximally permitted tolerance of the SDI functions for movement into the blocked direction. Due to mechanical conditions, the actually tolerated movement into the blocked direction can be up to 7° greater than this parameter value.

13.8 Function assignment

13.8.1 Safety-related inputs

10132.3 – 10132.10 F-DI0 – FDI7 interlocking

The drop-down list contains the following options:

- Not active:

Interlocking function is not active.

- Active:

The process value of the F-DI that controls the safety functions and that is sent via the safe process input data remains locked in a safe state until the error is acknowledged.

After starting the S12 safety option, all process values of F-DIs parameterized for interlocking are in a locked/safe state, irrespective of the current input information.

10132.11, 10132.14, 10132.17, 10132.20, 10132.23, 10132.26, 10132.29, 10132.32 Function of F-DI0 – FDI7

The drop-down list contains the following options:

- No assignment:

The F-DI does not select any safety function. Its process value is still output via the safe process input data.

- STO:

The F-DI selects the STO function.

- SS1:

The F-DI selects the SS1c or SS1a function.

- SLS0, 1, 2, 3:

The F-DI selects one of the SLS function blocks.

- Acknowledgement of interlocking F-DI and error:

A 0-1 edge at the F-DI triggers an error acknowledgement, which cancels the locked state of F-DIs parameterized for interlocking.

With 2-channel evaluation, only the resulting process value (even-numbered channel number) can be assigned a function. A safety function can be assigned to more than one F-DI. In this case, the F-DIs are ANDed.

13.8.2 Safety-related outputs

10132.35, 10132.36 Function of F-DO0/1

The drop-down list contains the following options:

- No assignment:

The safety-related output is controlled by the safe process output data. In independent operation, the output is always deactivated.

- STO active:

The safety-related output can be deactivated by the safe process output data or by the "STO selected" function. If the output is controlled by the "STO selected" function, it switches simultaneously with the F-DO_STO output.

- STO selected:

The safety-related output can be deactivated by the safe process output data or by the STO function. If the output is controlled by the STO function, it switches simultaneously with the STO function selection.

The output is active as long as none of the other active control sources (process data, error responses, system state, STO/SBC function) demands deactivation.

14 Application examples

This chapter contains examples for starting up typical applications.

The examples show all startup steps in a table with the following sequence:

Startup step	
A	Electrical installation
B	Parameter setting
C	Startup of standard part / periphery (fieldbus)
D	Verification and validation

14.1 Example 1: Independent operation

The following chapter shows examples of how the safety functions STO and SS1(c) are realized. A speed sensor is not required to implement the safety functions. The safety functions are controlled via F-DI. The MOVIFIT® device in use is operated independently (i.e. no PROFIsafe connection).

- Use the S12B variant of the safety option for independent operation.

The following figure shows the application example:

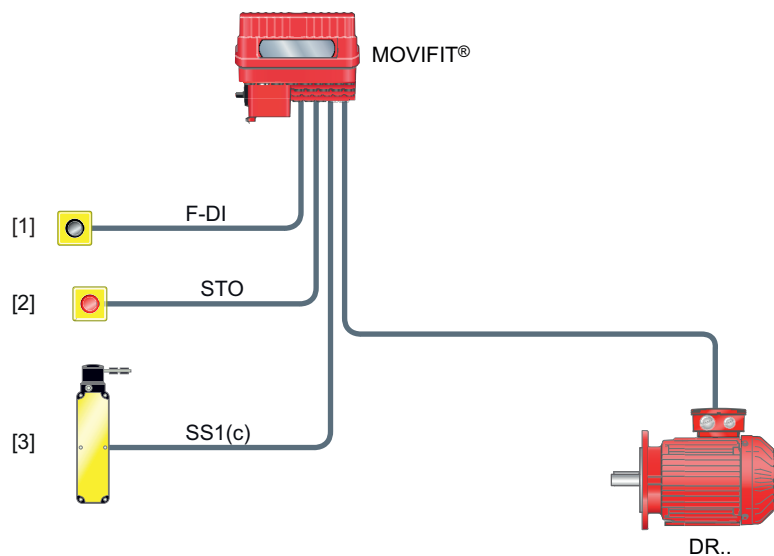

9007207957287051

- [1] Acknowledgement button
- [2] Emergency stop
- [3] Door switch

The following table shows the startup sequences.

A	Electrical installation	
1.	Connection of 24 V supply voltage	+24V -> X20:2 0V24 -> X20:3
2.	Connection of supply voltage for S12 safety option	X29:1 -> X29:7 X29:2 -> X29:8

A		Electrical installation
3.	Emergency stop [2]: (2-channel, non-equivalent)	X45:1 -> X45:21 X45:11 -> X45:23
4.	Door switch [3]: (2-channel, equivalent)	X45:2 -> X45:22 X45:12 -> X45:24
5.	Acknowledgement button [1]: (1-channel)	X45: 3 -> X45: 25
B		Parameter setting
1.	Switch on the device	LED status after powering up the device LED F-STATE = RED (flashing) LED RUN PS = OFF LED F-FUNC = YELLOW
2.	Start MOVITOOLS® MotionStudio and scan the network via the RS485 interface.	The safety option is detected in the network.
3.	Start the "Assist S12" parameterization tool.	A window for entering the serial number opens.
4.	Enter the serial number of the device.	The "Assist S12" parameterization tool starts.
5.	Call the default parameter set by clicking the [New] button.	The default parameter set is shown in the "input value" column.
6.	Adapt the following parameters in the parameter tree: General <ul style="list-style-type: none"> PROFIsafe fieldbus: 0 – not present F-DI <ul style="list-style-type: none"> F-DI 0/1 connection type: 2 – 2-channel non-equivalent F-DI 2/3 connection type: 1 – 2-channel equivalent F-DI 4 connection type: 0 – 1-channel SS1 <ul style="list-style-type: none"> Function: 1 – SS1c enabled Function assignment parameters <ul style="list-style-type: none"> Function of F-DI0: 1 – STO Function of F-DI2: 2 – SS1 Function of F-DI4: 9 – Acknowledgement interlocking F-DI and error 	

B		Parameter setting
7.	Click the [Download] button in the menu bar.	<p>The parameter set is downloaded to the device.</p> <p>LED status after the download: LED F-STATE = YELLOW (RUN, without verification) LED RUN PS = YELLOW LED F-FUNC = OFF LED FDI00 - FDI03 = YELLOW</p>
C		Standard part startup
1.	Startup the standard part as described in the MOVIFIT® FC operating instructions.	
D		Verification and validation
1.	Go to the "Assist S12" parameterization tool and verify individual blocks in the parameter tree. (Tick the "Verified" check box.)	After all blocks have been verified, the [Finish] button in the menu bar becomes active.
2.	Click the [Finish] button. Enter the system information in the dialog and click [OK] to confirm.	<p>The verification is downloaded to the device. Then, the acceptance protocol is opened for validation of the system.</p> <p>LED F-STATE = OFF (S12 not ready) LED RUN PS = OFF LED F-FUNC = YELLOW LED FDI00 - FDI03 = OFF</p>
3.	Print acceptance protocol and switch the device off and on.	The startup is now completed.
4.	Validate the system and document this.	

14.2 Example 2: PROFIsafe connection

The following example shows the implementation of the safety functions STO, SS1(a), and SLS. The STO and SS1(a) safety functions are controlled via process data. The SLS safety function is controlled via F-DI. In this example, an OSSD-capable light grid is installed.

The following figure shows the application example.

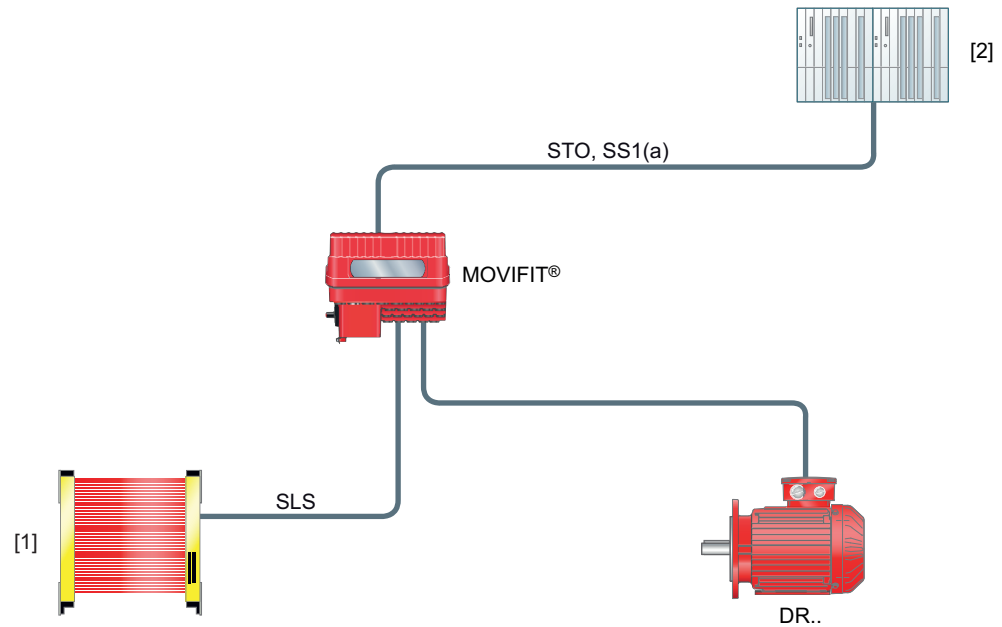

18014407212109195

- [1] Light grid (OSSD-capable)
- [2] PLC

The following table shows the startup sequence:

A	Electrical installation	
1.	Connection of 24 V supply voltage	+24V -> X20:2 0V24 -> X20:3
2.	Connection of supply voltage for S12 safety option	X29:1 -> X29:7 X29:2 -> X29:8
3.	Light grid (OSSD-capable) [1]	+24V -> X45:21 0V24 -> X45:31 OSSD1 -> X45:1 OSSD2 -> X45:11
4.	Connection of EI7C FS	Encoder track A -> X25:3 Encoder track /A -> X25:4 Encoder track B -> X25:13 Encoder track /B -> X25:14 +24V -> X25: 23 0V24 -> X25: 33

22865268/EN – 06/2016

B	Parameter setting	
1.	Switch on the device	LED status after powering up the device LED F-STATE = RED (flashing) LED RUN PS = OFF LED F-FUNC = YELLOW
2.	Start MOVITOOLS® MotionStudio and scan the network via the RS485 interface.	The safety option is detected in the network.
3.	Start the "Assist S12" parameterization tool.	A window for entering the serial number opens.
4.	Enter the serial number of the device.	The "Assist S12" parameterization tool starts.
5.	Call the default parameter set by clicking the [New] button.	The default parameter set is shown in the "input value" column.
6.	Adapt the following parameters in the parameter tree: General <ul style="list-style-type: none"> • Encoder type: 12 – EI7C FS F-DI <ul style="list-style-type: none"> • F-DI 0/1 connection type: 1 – 2-channel equivalent SS1 <ul style="list-style-type: none"> • Function: 2 – SS1a enabled SLS0 <ul style="list-style-type: none"> • Function: 1 – enable • Limit speed positive (n1): e.g. 500 rpm • Limit speed negative (n2): e.g. 500 rpm Function assignment parameters <ul style="list-style-type: none"> • Function of F-DI0: 3 – SLS0 	
7.	Click the [Download] button in the menu bar.	The parameter set is downloaded to the device. LED status after the download: LED F-STATE = YELLOW (RUN, without verification) LED RUN PS = YELLOW LED F-FUNC = OFF LED FDI00 - FDI03 = YELLOW
C	Startup of periphery (F-PLC / fieldbus)	
1.	PROFIBUS DP / PROFINET IO start-up	See "MOVIFIT® Function Level 'Classic' / 'Technology' " manual

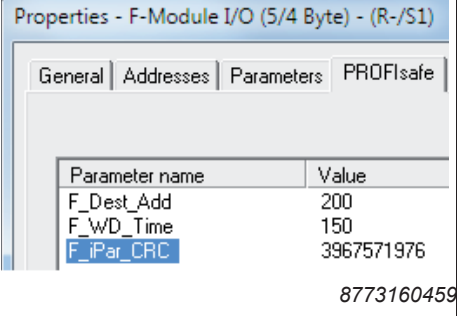
C Startup of periphery (F-PLC / fieldbus)		
2.	<p>Enter the current F_parameter in the PROFIsafe controller.</p> <p>Important: Read out the current F-iPar_CRC value in the "Status" of the "Assist S12" parameterization tool and enter it in the engineering tool of the higher-level PROFIsafe controller in the F_parameters of the MOVIFIT® device.</p>	 <p style="text-align: right;">8773160459</p>
3.	<p>Activation of the STO and SS1 safety functions:</p> <p>Activate PO0, bit 0 and 1 = "true".</p> <p>Acknowledge any errors, PO0, bit 7</p>	<p>STO and SS1 become active (PI0, bit 0 and 1 = "false")</p> <p>Safety part without errors</p> <p>F-State LED = GREEN</p> <p>RUN-PS = YELLOW</p>
4.	Startup of MOVIFIT® inverter	See MOVIFIT® operating instructions.
D Verification and validation		
1.	Go to the "Assist S12" parameterization tool and verify individual blocks in the parameter tree. (Tick the "Verified" check box.)	After all blocks have been verified, the [Finish] button in the menu bar becomes active.
2.	Click the [Finish] button. Enter the system information in the dialog and click [OK] to confirm.	<p>The verification is downloaded to the device. Then, the acceptance protocol is opened for validation of the system.</p> <p>LED F-STATE = OFF (S12 not ready)</p> <p>LED RUN PS = OFF</p> <p>LED F-FUNC = YELLOW</p> <p>LED FDI00 - FDI03 = OFF</p>
3.	Validate the system and document this.	The startup is now completed.

15 Technical data

15.1 Safety characteristics

15.1.1 Overall component: S12 safety option

The tables below show the safety characteristics of the overall component.

Designation	Characteristic safety values according to	
	IEC 62061 / IEC 61508	EN ISO 13849-1
Classification	SIL 2 ¹⁾	PL d
System structure	HFT = 0	Category 2
Operating mode selection	High demand	–
Probability of dangerous failure per hour (PFHd value)	$< 1.5 \times 10^{-8}$ 1/h	$< 1.5 \times 10^{-8}$ 1/h
Mission time / service life	20 years	
Proof test interval	Not required	–
Safe state	<ul style="list-style-type: none"> • PROFIsafe: Logic value "0" for all safety-related process values • Safety-related F-DO outputs: Outputs deactivated (logic "0")²⁾ 	
Safety functions	<ul style="list-style-type: none"> • STO, SS1, SLS, SDI (according to EN 61800-5-2) • Safety-related digital inputs and outputs • PROFIsafe communication 	

1) The S12 safety option is a subsystem of type B according to IEC 61508.

2) When a safety-related output is used to control the STO function of the inverter, the function is activated in a safe state.

15.1.2 Extended safety class for safety-related digital inputs and outputs

The following tables show the safety characteristics for safety-related digital inputs and outputs.

Designation	Characteristic safety values according to	
	IEC 62061 / IEC 61508	EN ISO 13849-1
<ul style="list-style-type: none"> • Safety-related inputs • Safety-related outputs (sourcing/sinking) • PROFIsafe 		
Classification	SIL 3	PL e
System structure	HFT = 1	2 channels (corresponds to category 3)
Probability of dangerous failure per hour (PFHd value)	$< 1 \times 10^{-9}$ 1/h	$< 1 \times 10^{-9}$ 1/h

Designation	Characteristic safety values according to	
	IEC 62061 / IEC 61508	EN ISO 13849-1
<ul style="list-style-type: none"> • Safety-related outputs (sourcing/sinking) • PROFIsafe 		
Classification	SIL 3	PL e
System structure	HFT = 1	2 channels (corresponds to category 3)
Probability of dangerous failure per hour (PFHd value)	$< 4 \times 10^{-9}$ 1/h	$< 4 \times 10^{-9}$ 1/h

15.1.3 MOVIFIT® FC

The following table shows the MOVIFIT® FC characteristic safety values.

Designation	Characteristic safety values according to EN ISO 13849-1
Classification	PL d
Probability of dangerous failure per hour (PFHd value)	0 (fault exclusion)
Mission time/service life	20 years
Safe state	Safe torque off
Safety functions	STO, SS1 ¹⁾ according to EN 61800-5-2

1) With suitable external control

15.1.4 MOVIFIT® MC

The following table shows the MOVIFIT® MC characteristic safety values.

Designation	Characteristic safety values according to EN ISO 13849-1
Classification	PL d
Probability of dangerous failure per hour (PFHd value)	0 (fault exclusion)
Mission time/service life	20 years
Safe state	Safe torque off
Safety functions	STO, SS1 ¹⁾ according to EN 61800-5-2

1) With suitable external control

15.2 Technical data: S12 safety option

15.2.1 Voltage supply

Designation	Value
Option voltage supply 24V_O	DC 24 V -15% / +20% according to EN 61131-2
Max. internal consumption	<ul style="list-style-type: none"> • Internal consumption S12: ≤ 100 mA • Internal consumption including F-DI With all F-DI supplied via F-SS0/1: <ul style="list-style-type: none"> – S12A: ≤ 160 mA (when using mechanical switches) – S12B: ≤ 200 mA (when using mechanical switches)
Total current consumption	Internal consumption of S12 + output current F-DO00 + F-DO01 + F-DO_STO + F sensor supply
Electrical isolation	Isolation between safety electronics (24V_O) and all other supply voltages

15.2.2 Safety-related inputs

Designation	Value	
<ul style="list-style-type: none"> F-DI00 – F-DI03 (S12 type A) F-DI00 – F-DI07 (S12 type B) 		
Features	according to EN 61131-2 DC 24 V, type 3	
Signal level	-3 V – +5 V +11 V – +30 V	Logic "0" = input LOW Logic "1" = input HIGH
Reference ground for F-DI	0V24_O	
Input impedance	ca. 3 kΩ	
Type. Power demand	0.21 W at 24 V	
Input filter time, parameterizable	4 ms – 250 ms	
Permitted cable length	30 m	
Minimum input signal duration ¹⁾	Filter time + 50 ms	
Response time (input switches -> bit F-DI. in the PROFIsafe user data updated)	1-0 transition: ≤ 2 x input filter time + 20 ms 0-1 transition: ≤ 2 x input filter time + 50 ms	
Error response time with single-pole connection	No greater than the response time without error	
Rise rate of input signal	> 120 V/s	

1) Minimum duration of an activation or deactivation pulse that is guaranteed to be processed by the system and sent with the PROFIsafe user data for at least one bus cycle.

15.2.3 Sensor supply of pulse outputs

Designation	Value	
<ul style="list-style-type: none"> F-SS0, F-SS1 		
Features	DC 24 V output according to EN 61131-2, protected against short circuits and overloads, no electrical isolation	
Rated current	250 mA	
Internal voltage drop	2 V	
Short-circuit protection	Electronic, response value: 0.7 A – 2.1 A	
Pulsed voltage supply (if activated)	F-SS 6 ms energized (HIGH), 2 ms deenergized (LOW)	
Permitted cable length	30 m (per sensor)	

15.2.4 Safety-related outputs

Designation	Value
<ul style="list-style-type: none"> F-DO_STO, F-DO00, F-DO01 (S12 type A) F-DO_STO (S12 type B) 	
Features	DC 24 V outputs according to EN 61131-2 Short circuit and overload protection
Permissible total current of outputs	≤ 1.9 A
Rated current	
F-DO00, F-DO01	1.9 A
F-DO_STO	1 A
Leakage current (with "0" signal)	≤ 1 mA
Internal voltage drop	Sourcing/sinking connection: 3 V Sourcing connection: 2 V
Permitted loads (each output)	<ul style="list-style-type: none"> STO deactivation: <ul style="list-style-type: none"> – 1 MOVIFIT® FC or – 1 MOVIFIT® MC (1 – 3 MOVIMOT®) with SB1 option Capacitive load: ≤ 130 µF Inductive load: <ul style="list-style-type: none"> 0.5 H at maximum current ≤ 2 H at < 1 A ≤ 10 H at < 0.3 A
Switching frequency at capacitive load	Max. 2 Hz
Response threshold wire break monitoring	150 mA
F-DO00, F-DO01	
Short-circuit protection	10 A – 24 A
Overload protection	Response value:
F-DO00, F-DO01	2.4 A – 2.7 A
F-DO_STO	1.2 A – 1.4 A
Test pulses	250 µs – 5000 µs (can be set in steps of 250 µs)
Permitted cable lengths	Max. 30 m
Bus response time (bit F-DO. in the PROFIsafe user data updated → output switches)	≤ 8 ms
Terminal response time (assigned F-DI. terminal switches → output switches)	1-0 transition: ≤ 2 x input filter time + 10 ms 0-1 transition: ≤ 2 x input filter time + 40 ms

15.2.5 Encoder interface

Designation	Value	
Features	Encoder interface for HTL encoder signals A, A, B, B	
Permitted encoders	EI7C FS	
Signal level	0 V – +3 V: +10.7 V – +30 V:	Encoder track LOW (logic "0") Encoder track HIGH (logic "1")
Maximum operating speed	3600 1/min	
Max. permitted input frequency	1520 Hz	
Response time of speed measurement	Calculated according to the formula: Response time of speed measurement (in ms) = 13 + 7500 / n n: Speed in rpm	
Error response time of speed measurement ¹⁾	No greater than the response time without error	

1) The error response time is the total time from when an internal error occurs or an external error in the encoder circuit is detected until the S12 safety option goes to a safe state.

15.2.6 Ambient conditions

Designation	Value
Ambient temperature for the entire device	-25 °C to +40 °C
Climate class	EN 60721-3-3, class 3K3
Storage temperature	-25 °C to +85 °C (EN 60721-3-3, class 3K3)
Permissible oscillation and impact load	according to EN 61800-5-1
Overvoltage category	III according to IEC 60664-1 (VDE 0110-1)
Pollution class	2 according to IEC 60664-1 (VDE 0110-1) within the housing

15.3 Technical data MOVIFIT® MC (safety technology)

The table below provides the technical data for MOVIFIT® MC (safety technology). Also observe the technical data and approvals specified in the MOVIFIT® MC and MOVIMOT® MM..D operating instructions.

Designation	Value				
	Min.	Typical	Max.	Unit	
Safety-related 24V_P supply voltage (U _{IN} according to EN 61131-2)	20.4	24.0	28.8	V (DC)	
Short-circuit protection for 24V_MM (elec- tronic, response value)	1.4		4.5	A	
Input capacitance, after polar- ity protection diode	PROFIBUS, DeviceNet™	9	10	11	μF
	PROFINET, EtherNet/IP™	18	20	22	μF
Input capacitance MOVIMOT® MM..D (up to 3 connections)	see "MOVIMOT® MM..D Functional Safety" manual				
Current consumption MOVIMOT® MM..D (up to 3 connections)					
STO response time					

15.4 Technical data MOVIFIT® FC (safety technology)

The table below provides the technical data for MOVIFIT® FC (safety technology). The technical data and approvals detailed in the MOVIFIT® FC operating instructions must also be observed.

Designation	Value			
	Min.	Typical	Max.	Unit
Safety-related 24V_P supply voltage (U _{IN} according to EN 61131-2)	20.4	24.0	28.8	V (DC)
Input capacitance, after polarity protection di- ode	80	100	120	μF
Current consumption	130	150	170	mA
STO response time			150	ms

Index

A

ABOX replacement.....	145
Acceptance protocol.....	98
Acceptance protocol (file).....	105
Actuators	
1-channel, sourcing output.....	55
1-channel, sourcing/sinking output.....	54
Application example	
Independent operation.....	165
Operation with PROFIBUS DP.....	168
Operation with PROFINET IO.....	168
Operation with PROFIsafe connection.....	168
Assist S12	
Change password.....	104
Data management.....	105
Device data.....	112
Diagnostics.....	138
Display of parameterization steps.....	102
Encoder.....	117
Error memory.....	118
Fault memory.....	140
Inputs, representation.....	114
Menu bar.....	101
Outputs, representation.....	116
Parameterization.....	107
Parameterization tool.....	100
Parameterization window.....	103
Plausibility error indication.....	103
Process data.....	117
Safety functions.....	113
Status bar.....	104
Status displays.....	112, 138
Status of safety functions.....	113
Test mode.....	116
Tool bar.....	102
User interface.....	100

B

Block diagram	
MOVIFIT® FC, inverter.....	18
MOVIFIT® MC.....	15
Built-in encoder EI7C FS.....	57
Connection.....	57

C

Changing the password in Assist S12.....	104
Characteristic safety values	
MOVIFIT® FC.....	173
MOVIFIT® MC.....	173
Coasting time measurement.....	84
Conditions, safety.....	26
Configuration file.....	105
Connection	
Built-in encoder EI7C FS.....	57
Cable for EI7C FS encoder.....	61, 64
Encoder EI7C FS, connection cable.....	61, 64
Encoder EI7C FS, hybrid ABOX.....	62
Encoder EI7C FS, standard ABOX.....	59
I/O terminal with S12A safety option.....	41
I/O terminal with S12B safety option.....	42
MOVIFIT® FC.....	36
MOVIFIT® FC, Wiring diagram.....	37
S12 safety option.....	40
S12A safety option, I/O terminals.....	41
S12B safety option, I/O terminals.....	42
Standard ABOX.....	40
Connection type (parameter).....	156
Connection types.....	78
Control of outputs.....	82
Copyright notice.....	11
CRC value.....	96
Crossfault monitoring.....	43, 79
Crossfault monitoring (parameter).....	157

D

Data exchange with the S12 safety option.....	119
Control example.....	126
F periphery access in STEP 7.....	119
F periphery DB.....	119
F process input data.....	123
F process output data.....	122
F user data.....	121
Introduction.....	119
Data management.....	105
S12 safety option configured.....	106
S12 safety option not configured.....	106
Default parameterization (without Assist S12)....	87
Definitions.....	14

Designated use 12

Device data 112

Device replacement

 Replacing the ABOX 145

 Replacing the EBOX 142

Diagnostics of lines 53

Diagnostics via PROFIBUS DP 137

Diagnostics via PROFINET IO 137

Diagnostics with the S12 safety option

 Diagnostics LEDs 131

 Error in the safety module 136

 Error states 136

 PROFIsafe timeout 136

 Safety diagnostics using PROFIBUS DP 137

 Safety diagnostics via PROFINET IO 137

 with Assist S12 138

Diagnostics, coasting time measurement 84

Discrepancy time 78

Discrepancy time (t2) (parameter) 157

Distance to limit speed (n3) (parameter) 161

Distance to ramp (n4) (parameter) 162

Documents, applicable 11

Drive coasting 30

Drive safety functions

 SDI – Safe direction 76

 SLS – Safely limited speed 72

 SS1(a) – Safe stop 1 70

 SS1(c) – Safe stop 1 69

 STO – Safe Torque Off 67

E

EBOX replacement 142

EI7C FS built-in encoder 57

Electrical installation 31

 Installation instructions 31

 S12 safety option 40

 S12 safety option, standard ABOX 40

 Safe disconnection MOVIFIT® FC 36

 Safe disconnection MOVIFIT® MC 32

 Safety-related disconnection 38

 Safety-related inputs 43

 Safety-related outputs 51

 Terminal assignment 40

 Voltage supply of S12 safety option 39

Embedded safety notes 10

Encoder interface, technical data 177

Encoder type (parameter) 155

Encoder, representation in Assist S12 117

Error in the safety module 136

Error memory in Assist S12 140

Error memory, representation in Assist S12 118

Error response to overspeed (parameter) 162

Error states of the S12 safety option 136

Error table 146

Examples for the S12 safety control 126

Exclusion of liability 11

F

F periphery access in STEP 7 119

F periphery DB 119

F process input data 123

F process output data 122

F user data 121

F_CRC_Block_ID (parameter) 95

F_CRC_Length (parameter) 95

F_Dest_Add (parameter) 95, 96

F_iPar_CRC (parameter) 96

F_Par_Version (parameter) 95

F_SIL (parameter) 95

F_Source_Add (parameter) 95

F-DI pulsed sensor supply (parameter) 157

F-DI. switch test (parameter) 157

F-DI0 – FDI7 interlocking (parameter) 163

F-DO0/1 connection type (parameter) 158

F-DO0/1 line diagnostics (parameter) 158

F-DO0/1 test duration (t2, t3) (parameter) 158

F-DO0/1 wire break monitoring (parameter) 159

F-DO-STO line diagnostics (parameter) 158

F-DO-STO test duration (t1) (parameter) 158

F-DO-STO wire break monitoring (parameter) .. 158

Files, project-relevant 105

FS logo 27

Function (parameter) 159, 161

Function assignment 82

Function of F-DI0 – FDI7 (parameter) 163

Function of F-DO0/1 (parameter) 164

Functional description

 MOVIFIT® FC, inverter 19

 MOVIFIT® MC 16

G

Data backup	
Unit replacement	142

H

Hazard caused by a coasting drive	30
Hazard symbols	
Meaning.....	10
Hybrid ABOX	
Connection of I/O terminal with S12A option..	41
Connection of I/O terminal with S12B option..	42

I

I/O terminal with S12A safety option, connection	41
I/O terminal with S12B safety option, connection	42
Independent operation (no connection to PROFIsafe)	88
Independent operation, application example.....	165
Information	
Designation in the documentation	9
Input filter.....	79
Input filter time (t1) (parameter).....	156
Inputs, safety-related	43, 77
Installation instructions	31
Installation requirements	28
Interlocking logic.....	82
Intermittent sensor supply	43
IO error effects (parameter).....	155
iPar-CRC (parameter)	96

J

Jumpers 24 V supply	38
---------------------------	----

L

Last opened file	105
LED	
"FDI."	132
"FDO."	132
"F-FUNC"	132
"F-STATE"	133
Line diagnostics.....	53
Load, permitted	51

M

Maximum motor speed (n1) (parameter).....	155
Minimum motor speed (n2) (parameter).....	156

Monitoring time (parameter)	96
-----------------------------------	----

MOVIFIT® FC

Connection	36
Safety concept, block diagram	18
Safety concept, functional description.....	19
Safety concept, restrictions	19
Technical data, safety technology	178
Terminal assignment	36
Wiring diagram	37

MOVIFIT® MC

Characteristic safety values	173
Safety concept, block diagram	15
Safety concept, functional description.....	16
Safety concept, restrictions	17
Technical data, safety technology	178

N

Nameplate of MOVIFIT®, complete device	27
Negative limit speed (n2) (parameter).....	161
Notes	
Meaning of the hazard symbols	10

O

Other applicable documentation.....	11
Outputs, safety-related	51, 80

P**Parameter**

F_CRC_Block_ID	95
F_CRC_Length	95
F_Dest_Add	95, 96
F_iPar_CRC	96
F_Par_Version	95
F_SIL.....	95
F_Source_Add	95
F-DI. Switch test	157
SS1a Distance to ramp (n1)	160
SS1a ramp monitoring delay (t2).....	160
SS1a STO function selection delay (t4)	160

Parameter setting

Change.....	109
Display.....	109

Parameterization

Procedure.....	107, 108
Representation in Assist S12	103

Parameterization steps, representation in Assist S12	102	STO status display delay (t2)	159
Parameters		Passivation	120
Connection type	156	Performance level	16, 19, 29
Crossfault monitoring	157	Permitted coasting time (t3) (parameter).....	159
Discrepancy time (t2)	157	Plausibility errors, representation in Assist S12	103
Distance to limit speed (n3).....	161	Positive limit speed (n1) (parameter)	161
Distance to ramp (n4).....	162	Process data, representation in Assist S12.....	117
Encoder type	155	Product names	11
Error response to overspeed.....	162	PROFIBUS DP, diagnostics with S12 safety option .	137
F-DI pulsed sensor supply.....	157	PROFINET IO, diagnostics with S12 safety option ..	137
F-DI0 – FDI7 interlocking	163	PROFIsafe address setting	91
F-DO0/1 connection type	158	PROFIsafe destination address (parameter).....	95
F-DO0/1 line diagnostics	158	PROFIsafe fieldbus (parameter)	155
F-DO0/1 test duration (t2, t3)	158	PROFIsafe source address (parameter)	95
F-DO0/1 wire break monitoring	159	PROFIsafe timeout.....	136
F-DO-STO line diagnostics	158	PROFIsafe version (parameter)	95
F-DO-STO test duration (t1).....	158	R	
F-DO-STO wire break monitoring.....	158	Ramp monitoring delay (t1) (parameter)	161
For F-DI	156	Ramp time (t2) (parameter).....	162
For F-DO	158	Reintegration of S12 safety option	120
For input function assignment	163	Replacing the ABOX	145
For output function assignment.....	164	Replacing the EBOX	142
For SLS (general).....	161	Response times of S12 safety option	130
For SLS 0, 1, 2, 3	161	Restrictions	
For SS1	159	MOVIFIT® FC, inverter	19
For STO.....	159	MOVIFIT® MC.....	17
Function.....	159, 161	Rights to claim under limited warranty	10
Function of F-DI0 – FDI7	163	S	
Function of F-DO0/1	164	S12 safety option	
Input filter time (t1)	156	Configuration in STEP7	93
IO error effects	155	Connection	40
Maximum motor speed (n1)	155	Control example	126
Minimum motor speed (n2)	156	Data exchange	119
Negative limit speed (n2).....	161	Data exchange, introduction.....	119
Permitted coasting time (t3)	159	Diagnostics LEDs	131
Positive limit speed (n1)	161	Diagnostics with Assist S12	138
PROFIsafe fieldbus	155	Electrical installation.....	40
Ramp monitoring delay (t1).....	161	Error in the safety module	136
Ramp time (t2).....	162	Error states.....	136
SDI function.....	161	Error table.....	146
SDI tolerance.....	162	F periphery access in STEP 7	119
Speed filter	162	F periphery DB	119
SS1a ramp time (t3)	160		
SS1c delay (t1).....	160		
STO delay (t1).....	159		

F process input data	123	SS1(c) – Safe stop 1	23, 69
F process output data	122	Status in Assist S12	113
F user data	121	STO – Safe Torque Off	21, 67
Fault memory	140	Safety notes	
Parameter setting	94	Definitions	14
PROFIsafe timeout	136	Designated use	12
Response times	130	Designation in the documentation	9
Safety diagnostics using PROFIBUS DP	137	General information	000
Safety diagnostics via PROFINET IO	137	Installation	13
Safety-related disconnection	38	Meaning of the hazard symbols	10
Safety-related inputs	43	Structure of embedded	10
Safety-related outputs	51	Structure of the section-related	9
Setting the PROFIsafe address	91	Target group	12
Standard ABOX	40	Transportation and storage	13
Startup of the fieldbus and the F-PLC	91	Safety option S12A, I/O terminal connection	41
Status displays	138	Safety option S12B, I/O terminal connection	42
Technical data	174	Safety telegram, length (parameter)	95
Voltage supply	39	Safety-related inputs	77
S12A safety option, I/O terminal connection	41	Safety-related outputs	80
S12B safety option, I/O terminal connection	42	Safety-relevant conditions	26
Safe disconnection		Installation requirements	28
MOVIFIT® FC	36	Sensor and actuator requirements	28
MOVIFIT® MC	32	Startup requirements	29
Safety characteristics		SDI – Safe direction	24, 76
S12 safety option	171	SDI function (parameter)	161
Safety-related inputs and outputs	172	SDI tolerance (parameter)	162
Safety concept		Section-related safety notes	9
Assist S12	25	Sensor and actuator requirements	28
MOVIFIT® FC, functional description	19	Sensors	
MOVIFIT® FC, inverter	19	1-channel, with contact	43
MOVIFIT® FC, restrictions	19	2-channel, active	47
MOVIFIT® MC, block diagram	15	2-channel, with contact	44
MOVIFIT® MC, functional description	16	2-channel, with semiconductor outputs (OSSD) .	49
MOVIFIT® MC, restrictions	17	Setting the safety function parameters	89
S12 safety option	20	Signal words in safety notes	9
Safety concept, block diagram	18	SIL safety class (parameter)	95
Safety functions	21	SLS – Safely limited speed	24, 72
Safety functions	21, 67	Speed filter	75
In Assist S12	113	Speed filter (parameter)	162
Inputs, representation in Assist S12	114	SS1(a) – Safe stop 1	22, 70
Outputs, representation in Assist S12	116	SS1(c) – Safe stop 1	23, 69
Parameter setting	89	SS1a distance to ramp (n1) (parameter)	160
SDI – Safe direction	24, 76	SS1a ramp monitoring delay (t2) (parameter) ...	160
SLS – Safely limited speed	24, 72	SS1a ramp time (t3) (parameter)	160
SS1(a) – Safe stop 1	22, 70		

SS1a STO function selection delay (t4) (parameter) 160	Switch test 79
SS1c delay (t1) (parameter) 160	T
Standard ABOX	Target group 12
Connection of I/O terminal with S12A option.. 41	Technical data 171
Connection of I/O terminal with S12B option.. 42	Ambient conditions 177
Standards 16, 19, 29	Encoder interface 177
Startup	MOVIFIT® FC, safety technology 178
Configuration in STEP7 93	MOVIFIT® MC, safety characteristic values . 173
Default parameterization (without Assist S12) 87	MOVIFIT® MC, safety technology 178
Fieldbus and the higher-level F-PLC 91	S12 safety option 174
Independent operation (without PROFIsafe con- nection) 88	Safety-related inputs 175
Parameter setting 94	Safety-related outputs 176
PROFIsafe and higher-level F-PLC 91	Sensor supply cycle outputs 175
Setting the PROFIsafe address 91	Terminal assignment 40
With PROFIsafe connection 88	MOVIFIT® FC 36
Startup requirements 29	Test mode 83, 116
Status displays 112	Test pulses 53
Status displays in Assist S12 138	Trademarks 11
STO	Transport (safety notes) 13
Jumper plug 134	V
STO – Safe Torque Off 21, 67	Validation 99
STO delay (t1) (parameter) 159	Verification 97
STO jumper plug 134	X
STO status display delay (t2) (parameter) 159	X71F, STO plug connector (optional) 135

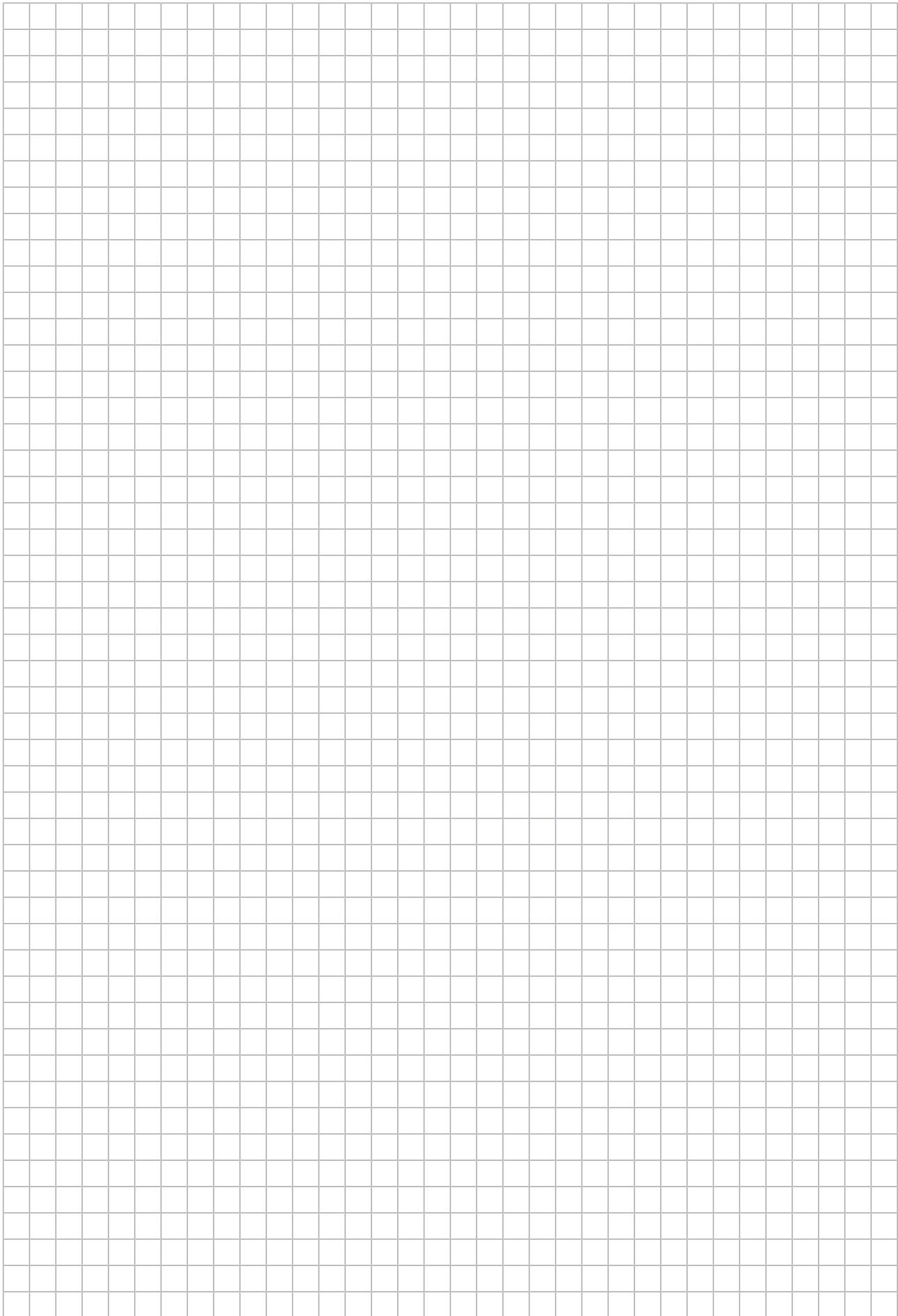

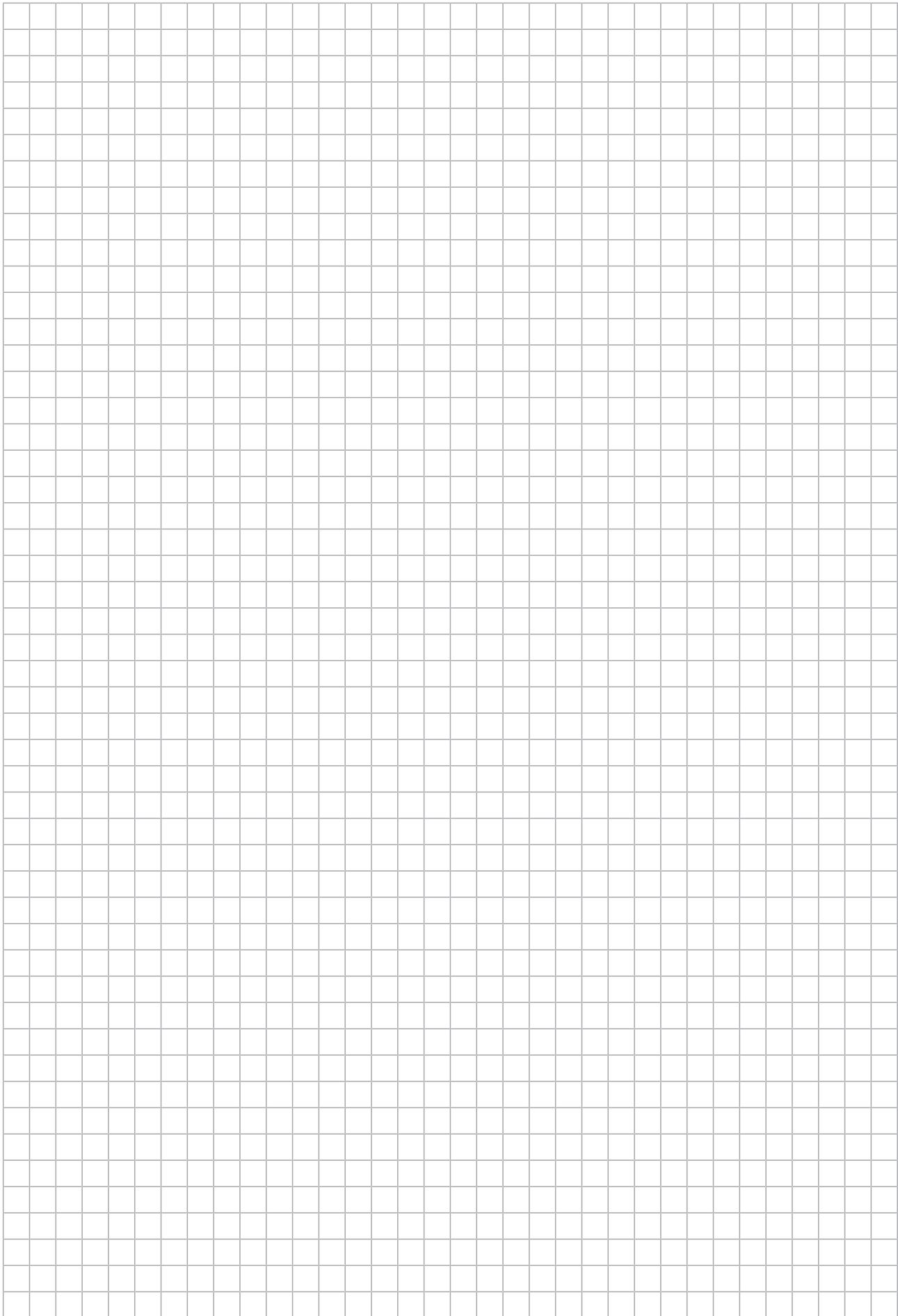

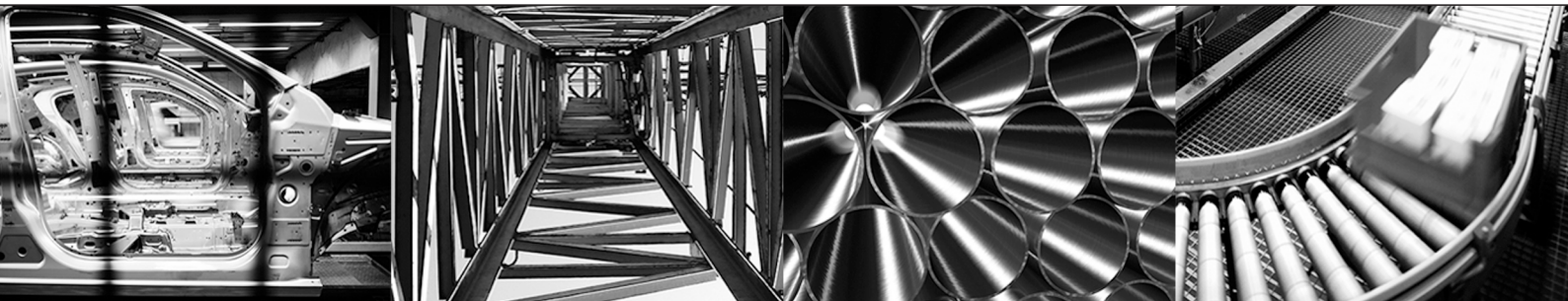



SEW-EURODRIVE
Driving the world

SEW
EURODRIVE

SEW-EURODRIVE GmbH & Co KG
P.O. Box 3023
76642 BRUCHSAL
GERMANY
Phone +49 7251 75-0
Fax +49 7251 75-1970
sew@sew-eurodrive.com
→ www.sew-eurodrive.com