

NE 1/ 3926 GB

**RENAULT PREMIUM
DXi 11
330 - 380 - 440**

50 21 022 931 - 06/2005

english edition

Contents

Chapter

FOREWORD.....	A
PRESENTATION.....	B
DRIVING.....	C
USE OF THE EQUIPMENT.....	D
FEATURES - SERVICING.....	E
QUICK BREAKDOWN REPAIR.....	F
BODYBUILDER INFORMATION.....	G

RENAULT TRUCKS

Société Anonyme au capital de 50 000 000 €
Siège social : 99, route de Lyon
69802 Saint-Priest
Siret 954 506 077 00 120 - RCS LYON B 954 506 077

The manufacturer reserves the right to make any modifications deemed necessary during production. This handbook should not be considered as a specification for the model in question.

© **RENAULT TRUCKS SA - 2004 - Imprimé en France**

Alphabetical index

A

Accelerator pedal, C4-6
ADR vehicle (transport of dangerous materials), B3-4, C5-3
Adjusting the steering wheel, B2-50
Advice, E20-6
Air filters, E6-6
Air tanks, E2-3, E26-2
Air vents, B2-60
Alarm, B1-9
Anti-slip regulator (ASR), C6-2
APM (Air Production Management) unit, E26-1
Axle, steering maintenance operations, E5-9

B

Beam height correction, E3-9
Bleeding the fuel system, E8-5
Bodywork, G-1
Brakes maintenance operations, E5-10
Brakes types, E19-1
Brake pads, E19-2
Brake valve, E26-1
"EBS" braking system, C4-42
Bulbs, E3-1
Bunks and storage compartments, B2-69

C

Cab overhead lights, B2-74
Cab tilting system oil capacity, E18-1
Cab tilting, B1-20, E18-1
Chassis, cab, electrics maintenance operations, E5-11
Checking the oil level, E2-2, E6-3
Child safety, B3-2
Circuit capacity, E9-1
Cleaning the cockpit, E28-2
Cleaning the fascia panel, E28-2
Cleaning the headlamps, E28-2
Cleaning the seats, E28-2
Clutch fluid level, E2-1
Clutch system, E9-2
Clutch types, E9-1

Clutch, gearbox, power take-off maintenance operations, E5-8
Combined lights and horn switch, B2-47
Coolant level, E2-1
Coolant, E7-1
Cruise control, C4-3

D

Daily checks, E2-1
Dashboard, B2-6
Description of Optidriver 2, C4-29
Diagnostic socket, D2-1
Display test, C2-5
Doors, B1-2
Drive axle P 1395 A oil change, E15-2
Drive axle P13170 oil change, E15-1
Drive axle, prop shaft maintenance operations, E5-9
"Rear drive axle(s)" diff. lock, C6-1
Driving a solo tractor, C1-3
Driving Monitoring System, C4-20
Driving on difficult terrain, C6-1
DXi 11, E6-2

E

Economic driving, C1-3
Electrically operated rearview mirrors, B2-46
Electrically operated sun-roof, B2-53
Electric window raiser controls, B2-52
Electronic air suspension, D1-9
Electronic speed limiter, C4-6
Emergency brake, C4-49
Engine idling speed adjustment device, C3-5
Engine immobilizer, C2-4
Engine maintenance operations, E5-6
Engine oil capacities, E6-2
Engine oil level gauge, C2-2
Engine operating speed, C4-2
Engine starting with pilot-controlled starter feature, C3-3
"ESP" (electronic stability program) system, C4-47

Alphabetical index

Exhaust brake and exhaust brake
"OPTIBRAKE" (with Optidriver 2
gearbox), C4-12
Exhaust brake with engine brake
"OPTIBRAKE" (with manual gearbox),
C4-10
Exhaust brake with engine brake
"OPTIBRAKE" coupled with a VOITH
hydraulic retarder (with Optidriver 2
gearbox), C4-14
Exhaust brake with or without engine
brake "OPTIBRAKE" coupled with a ZF
hydraulic retarder (with ZF gearbox),
C4-18
Exhaust brake (with manual gearbox),
C4-9
External storage locker(s), B1-23

F

Fall-back mode (lever disconnected),
C4-40
Fan-coil heater filter, E21-2
Fast idling device, C3-6
Fault display, C2-6
Fifth wheel coupling, D1-2
"FONTAINE" sliding fifth wheel
coupling, D1-8
"GEORG FISCHER" fifth wheel
coupling, D1-4
"JOST" fifth wheel coupling, D1-5
"JOST" 42 fifth wheel coupling, D1-6
Fifth wheel types, E27-1
Filling the engine cooling system, E7-6
Filter cartridge replacement, E17-1
Fire extinguisher, B3-3
First aid kit, B3-8
Front axle types, E14-1
Front axle, E14-1
Front grille, B1-17
Front suspension, E16-1
Fuel filter(s), E8-3
Fuel preheater, E8-8
Fuel tank capacities, E8-1
Fuel tank(s), B1-25, E8-6
Fuel, E4-3
Fuses, E3-10

G

Gearbox oil capacity, E10-2
Gearbox types, E10-1
ZF gearbox + Intarder oil change, E10-9
General usage instructions for
commercial vehicles, A-2

H

Headlamps wash reservoir, E2-5
Headlights adjustment, B2-49, E3-8
Heated windscreen, B2-46
Heating - Ventilation, B2-54
Heating, air conditioning maintenance
operations, E5-12
Hydraulic power-assisted steering, C4-1,
E17-3

I

Ignition switch, C2-5
Independent heating, B2-61
Infomax, D2-1
Inspection / lubrication, E27-1
Instrument panel, B2-10
International standards, E4-7

K

Keys, B1-1
Key to switches, B2-24
Key to warning pictograms, B2-16
Key to "gearbox" warning pictograms,
B2-21
Key to "tachograph" warning pictograms,
B2-22

L

Location of jack and onboard kit, F-2
Lubricants, E4-4
Lubrication diagram(s), E4-12

M

Maintenance display, C2-7
Maintenance, E16-1, E21-1
Master switch, B1-26

Alphabetical index

"ADR" master switch (transport of dangerous materials), B1-27
Monitoring / management equipment, D2-1
Multi-function information display, B2-28

O

Oil capacity, E15-1
Oil change, E6-4, E10-8
Oil filters, E6-4
Onboard radio, B2-74
Optidriver 2 gearbox oil change, E10-3
Optidriver 2 gearbox, C4-26, E4-7, E4-9

P

Parking brake, B2-51, C4-50
Power take-off types, E12-1
Power take-off, D1-20, D1-21, E4-9
Precautions, E19-1
Preheating the engine cooling system, C1-4
Prior to getting into the vehicle, C2-1
Protecting diesel fuel against freezing and additives, E8-7

R

Radiator mosquito net, E7-2
Rational use of batteries, E23-6
Rear drive axle types, E15-1
Rear suspension, D1-9, E16-1
Refrigerator, B2-71
Regulatory test display, C2-5
Remote control battery, E3-18
Remote control box, D1-10
Retarder types, E11-1
Retarder, C4-7
VOITH retarder oil change, E10-6
Reversing buzzer, C4-41
Roof air vent, B2-53
Roof deflector, D1-25
Routine servicing, E3-1

S

Seats, B2-1

Seat belts, B3-1
Servicing frequencies, E5-1
Servicing, E22-1
Side fairings, B1-18
Soundproofing screens and heat shields, E6-1
Spare wheel carrier, F-4
Starter types, E25-1
Starting the engine, C3-1
Starting the vehicle using an external power source, F-1
Steering types, E17-1
Stopping the engine, C5-1
Suspension maintenance operations, E5-10

T

Test procedure, D1-19
Tightening the wheel nuts, E20-2, F-7
Towing, F-8
Trade equipment, D1-1
Trailer brake, C4-49
Turbocharger, E6-8
Tyres, E2-4
Tyre features, E20-1
Tyre pressures, E20-3

U

Use at high altitude, C1-2
Use during the summer or in hot climates, C1-2
Use during the winter or in cold climates, C1-1
Use in dusty atmospheres, C1-2
Use of the equipment, D1-1
Use on downhill runs, C4-37
Using the jack, F-5

V

Variable-drive cooling fan, E7-3
Vehicle identification, E1-1
4x2 vehicle with adjustable rear suspension, D1-11
4x2 - 6x2 vehicle with adjustable rear suspension, D1-13

Alphabetical index

4x2 - 6x2 vehicle with integral suspension, D1-17

W

Warranty, E4-1

Washing the body, E28-1

Washing the vehicle, E28-1

Welcome onboard your new RENAULT, A-1

Welding on vehicle, G-1

Wheels, tyres maintenance operations, E5-12

Wheel chocks, B3-3

Windscreen wash reservoir level, E2-4

Windscreen wiper, windscreen wash and headlamps wash control, B2-49

Working spotlight (tractor), D1-1

A-1 Foreword

Welcome onboard your new RENAULT

You have now taken possession of your new vehicle.

We trust that it will give you the entire satisfaction you have the right to expect and which was the reason for your original choice.

This driving and servicing handbook has been laid out to provide all the information you need and will enable you to:

- Get to know your Renault better and, on the same occasion, to derive the maximum of benefit from all the technical perfections with which it is endowed, under the very best working conditions.
- Permanently guarantee optimum operation by simply - but strictly - observing maintenance recommendations.
- Cope with any minor malfunctions not requiring assistance from a specialist, without losing too much time.



This handbook covers all the options proposed to customers.

Take into account only indications corresponding to the model in your possession.

The few moments devoted to reading this handbook will be well worthwhile on account of the information it contains and the new technical features you will discover. If any details remain unclear, our dealer staff will be pleased to provide you with any further information you may require.

To read the text:

The reference numbers, figures and letters mentioned in the text refer back to two types of illustration:

- *Figures correspond to figures or photographs situated in proximity to the text.*
- *Letters, sometimes followed by a figure, correspond to the instrument panel diagram to be found inside the handbook.*

"Bon voyage" at the wheel of your Renault !

RENAULT TRUCKS: Frontier-free service

Renault Trucks 24/24 has been in operation for several years now.

19 emergency call centres are listening in for you 365 days a year .

Spare parts officially approved by RENAULT TRUCKS meet both the requirements of the vehicle specification and the regulations in force. Only premium Renault parts will ensure:

- Original Equipment safety standards,
- Full Manufacturer's Warranty,
- Maintenance of original characteristics and performance.

A-2 Foreword

General usage instructions for commercial vehicles

If you are a professional driver using your own vehicle, or a haulier entrusting one of your vehicles to a member of your staff, it is essential to follow and ensure the application of the following instructions. They are only a reminder of the basics of the trade and standard professional practice and in no way are to be taken as exhaustive. In this way you will obtain the maximum profit from your material and prevent any risk of accidents and incidents.

1. A few basic instructions

- Every driver must possess all necessary licences and should only drive when physically fit and sufficiently rested.
- The vehicle must be in conformity with current legislation in the country or countries in which it is used.
- Any signs indicating hazardous substances must be affixed and be in good condition.
- Loads:
 - All-up or per-axle weights (regulatory or technical) must not be exceeded.
 - Loading and securing of loads must be carried out using conventional procedures, tarpaulins and side curtains must be correctly stretched and fastened and doors and sideboards locked, etc...
- In the cab:
 - Never carry dangerous products (such as petroleum, trichlorethylene, thinner, etc.).
 - If an animal is carried, it must be kept away from the driving position.
- Getting in and out of the vehicle:
 - Use the steps and the handles provided. Never jump down from the vehicle. When leaving the vehicle, observe the traffic flow, particularly if you have been driving for a long time.
 - Take extra care when the climatic conditions are bad (rain, snow, ice) and at night.



- **USE IN CLOSED PREMISES:**
 - **NEVER LEAVE THE ENGINE RUNNING IN CLOSED OR POORLY VENTILATED PREMISES. THE EXHAUST GASES CONTAINED EXTREMELY TOXIC CONSTITUENTS. THEIR CONCENTRATION MAY HAVE VERY SERIOUS EFFECTS ON YOUR HEALTH.**

A-3 Foreword

2. Before getting into the vehicle, check:

- General condition of your vehicle, visually (as per handbook);
- Tyre condition, tyre pressures (including the spare wheel), and that nothing is jammed between the twin wheels;
- Cleanliness of cab windows, rearview mirrors, headlights and other lights and number plates;
- Regulatory and optional lighting systems for correct operation;
- Semi-trailer and/or trailer for correct coupling (hook, brake hoses - colour coding - electrical connector...);
- For the presence and contents of the onboard tool kit;
- In winter, for the presence of anti-skid chains and that they are securely fastened;
- Vehicles equipped with side guard panels and beams should be permanently provided with this equipment. At the time of removal, make sure that the locks are correctly locked and tighten the setscrews moderately.

3. In the cab

- Check the condition of the non-slip foot pedal covers.
- Ensure that the safety controls (steering wheel, foot pedals, gear lever etc...) are never cleaned with a slippery product like silicone).
- Adjust your driving position:
 - Steering wheel: check that the steering column is locked.
 - Seat: check that the seat is firmly locked.
 - Rearview mirrors.
 - Seat belt: it is compulsory to wear one, so buckle up.
 - Onboard children: comply with the laws in force.
- Before starting the engine: ensure that the gear lever is properly in neutral.
- Check that all instrument panel indications are normal (if you are not certain of what the nominal readings are supposed to be, refer to the Driving & Servicing Handbook).

Analogue tachograph

- Check that the tachograph chart is in place in the tachograph unit and that the unit is working properly.

Digital tachograph

- Check that the driver's tachograph chart **1** is in place in the tachograph tray.
If there is a 2nd driver, Check that his tachograph chart is in place in the tachograph tray **2**.
Check that the tachograph unit is working properly.

A-4 Foreword

4. When driving

- If you detect any anomaly in the way the vehicle is operating, stop and locate the malfunction.
Do not move off again until you are sure that the incident has not impaired technical performance and safety.
- When driving, the use of some of the standard-fitted equipment, and other optional or added equipment is strictly forbidden (i.e. hand-operated sun-roofs, television sets, etc...) or only permitted if all necessary precautions are taken so as not to affect road safety (cigar lighter, manual selection of radio stations, CB, onboard telephone...).
- Adapt your driving style to suit your load (cant or bend, if the centre of gravity is high, etc...) to take account of weather conditions and the time of day.
If necessary, adjust the headlight beam levels.
- Never shut down the engine when the vehicle is moving (as this will cut off the supply to the power-assisted steering system and could decrease brake effectiveness).

5. When parking

- Check that the vehicle is correctly parked (i.e. that it does not obstruct traffic flow or threaten the security of neighbouring installations).
- If the vehicle is going to remain stationary for some time, use one or more wheel chocks to prevent it from moving (e.g. semi-trailer compressed air leakage, or in black ice conditions...).
- Check that:
 - The parking brake is locked and immobilizes the road train or rig.
 - The gear lever is in neutral.
 - The battery isolating switch is open (turned off).
 - The electromagnetic retarder is switched off.
 - The air vents are not blocked (if an independent heater is used).
 - The parking lights are switched on at night.
- Check that you have not left in the cab:
 - important documents (personal, vehicle, load).
 - unaccompanied animals.

A-5 Foreword

6. When repairing / servicing the vehicle



Prior to carrying out any work on the electronic air suspension (other than calibration), place axle stands under the chassis.

- Check the tightness of the wheel nuts according to recommendations.
- Prior to tilting the cab:
 - Ensure there is enough necessary space available in front of the vehicle.
 - Set the limits of a safety perimeter **around the cab** inside which you must pay attention that nobody tries to cross that area or park in it, not only during the cab tilting operations but also when the cab is fully tilted.
 - Stop the engine, put the gear lever into neutral and make sure that no object is likely to fall onto the windscreen. If a refrigerator is fitted, drain it. Close the doors.
 - Tilt the cab as far as possible. If the cab is only partially tilted, wedge it to prevent accidental movement.
- If the engine is running:
 - Do not approach moving parts (fan, drive belts, etc...).
 - Do not turn off the electrical power supply (shut down the engine first).
- When climbing up onto or down from the ramp behind the cab (tractor), use the steps and grab handles provided. Never jump down from the ramp. Take care not to burn yourself (on the vertical exhaust pipe and silencer).
- Fuel is inflammable: if the fuel filler cap is open, smoking is forbidden and there must be no naked flame in the vicinity.
- Batteries are filled with acids, which can cause serious injuries. They must be handled with great care.
- If you start the engine using an external power source:
 - Use cables of the correct dimensions.
 - Make sure that the + and - polarities are connected properly.
- When changing a fuse, it is vital to use another fuse of the same size.
- Only specialists should install additional power lines.
- The installation of additional air lines requires a technical study carried out or approved by the manufacturer.
- It is strictly forbidden to heat polyamide hoses (braking circuit pipes).
- Raising the vehicle with a jack. chock the wheels prior to jacking.
- Immobilizing the vehicle: use one or several wheel chocks as necessary.
- Wheels and tyres:
 - Never check tyre pressures or inflate or deflate a tyre, which is hot.
 - Never stand in front of a tyre when checking the pressure or inflating it.
 - When fitting a roadwheel, take great care to centre wheels fitted with centring clamps (for trillex wheels, position the clamp at the segment crossover point).

A-6 Foreword

- Repairs on the open road: collect the fluids, which have been drained (such as oil, fuel, coolant...).
- With an eye to environmental protection, take into consideration the laws in force (recovery of oil / anti-freeze / cartridges).

When draining oils (engine / gearbox / drive axles), you run the risk of burning yourself (hot oil).

When draining coolant, you run the risk of burning yourself (hot fluid).

- Independent heater: use motor vehicle diesel fuel only.
- If anti-skid chains are used, the rear wings should be removed, road speed should be reduced and chain tension should be tested at regular intervals.

Any modification to circuits (electrical, electronic or compressed air) may have serious consequences. Such work should only be undertaken in agreement with the manufacturer. RENAULT TRUCKS decline any responsibility in the event of non-conformity in assembly.

Only genuine, original RENAULT TRUCKS parts and circuits defined by the manufacturer guarantee quality, safety and reliability.

By observing the above instructions, you will be using your vehicle in the best possible way. However, you must also carefully read the driving handbook and consult the RENAULT TRUCKS network whenever you need any further information.

We remind you that application of the contractual warranty by RENAULT TRUCKS is subject, among other things, to proof by the customer that servicing and maintenance of the vehicle have been carried out according to our recommendations (frequency, operations to be performed, quality of expendable and consumable products guaranteed by genuine certified or recommended spare parts, quality and training of repair mechanics and use of specific tools...). Observance of these recommendations will also guarantee long-term reliability of the vehicle.

Servicing and maintenance conducted by the RENAULT TRUCKS network is a guarantee of observance of these recommendations. If the operations are conducted outside our network, the customer must provide formal proof that our recommendations have been observed.

A-7 Foreword

Warnings

In this document, safety instructions are symbolized as follows:



DANGER! NON-OBSERVANCE OF THE PROCEDURE DESCRIBED OR LACK OF CARE OR ATTENTION RISK CAUSING SERIOUS INJURY OR EVEN DEATH.



WARNING! Any different or inappropriate working method risks causing damage to the product.



NOTE! Draws attention to particular or important points of the method.



Draws attention to special important points of procedures or regulations in force that must be obeyed without fail, especially those relative to the recovery and treatment of used parts and waste.

A-8 Foreword

B1-1 Presentation

Vehicle access and protection

Keys

Depending on your vehicle's equipment

Note down your key and remote control numbers here:

- **Ignition:**
- **Doors:**
- **Remote control:**

B1-2 Presentation

Doors

Opening from the outside

Unlock by inserting the key into lock (1).
Tilt handle (2) upwards and pull the door.

Closing

Push the door until it engages automatically.
Lock the door with the key in lock (1).



Opening of the door actuates the stepwell lighting and the overhead lights.

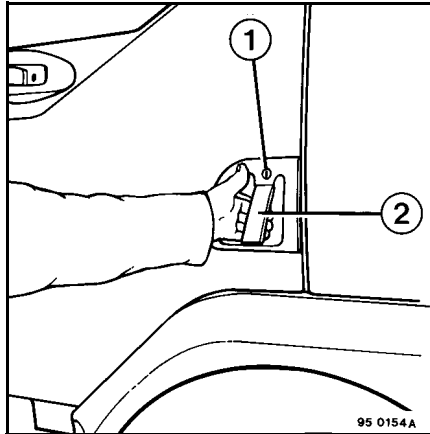

Opening from the inside

Unlocking:

Tilt handle (3) upwards and push the door.



With the door open, handle (3) tilted downwards, the door unlocks automatically upon closing.

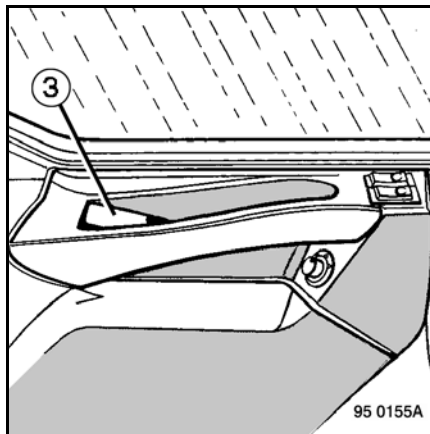

B1-3 Presentation

Closing:

Pull the door until it engages.

Locking:

With the door closed, tilt handle (3) downwards.

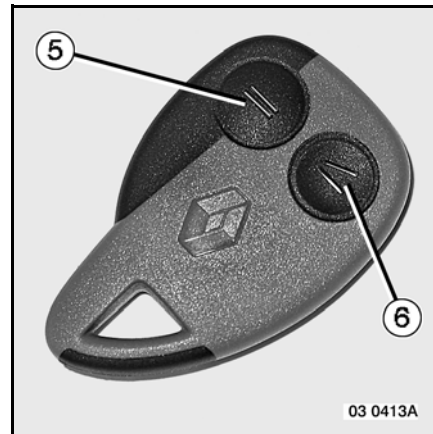

Central locking

Central locking from the inside:

Central locking is actuated:

- manually, by tilting handle (3) downwards,
- with the remote control, by pressing button (5),
- with dashboard switch (F4).



With the door open, handle (3) cannot be tilted downwards and the door unlocks automatically upon closing.

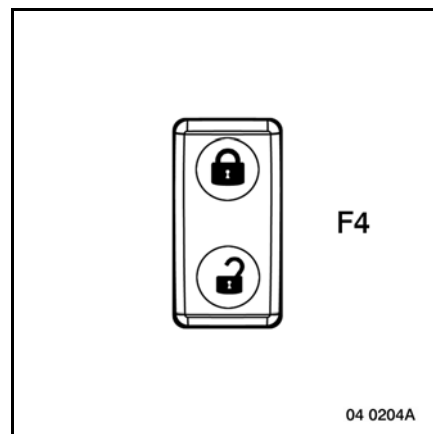

B1-4 Presentation



With the doors locked, prolonged pressing of switch (F4) in the locking position until the doors unlock, changes over from synchronized mode to de-synchronized mode and vice versa (pressing until unlocking).

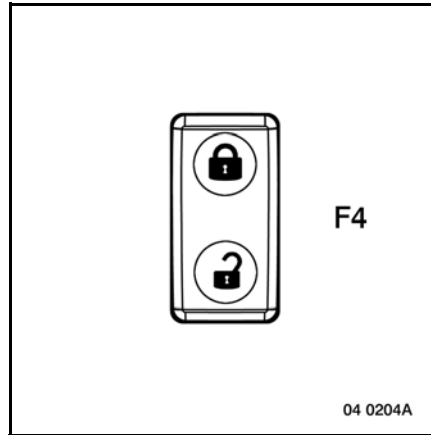

Synchronized mode:

- Simultaneous opening of the doors by dabbing button (6) on the remote control.
- Simultaneous opening of the doors by turning the key in the driver's or passenger's side door lock.

Desynchronized mode:

- Opening of the driver's door by dabbing button (6) on the remote control.
- Opening of the passenger's door by dabbing a second time on button (6) on the remote control.
- Opening of the driver's door by turning the key in the door lock once.
- Opening of the passenger's door by turning the key in the door lock a second time in less than 3 seconds.

Simultaneous closing of the doors by dabbing button (5) on the remote control.

Simultaneous closing of the doors by turning the key in the door lock a second time.

B1-5 Presentation

With the remote control

When you press locking button (5), the direction indicator warning light and the hazard lights warning light flash 4 times.

When you press unlocking button (6), the warning lights flash once.



Central locking is neutralized when the door is open.

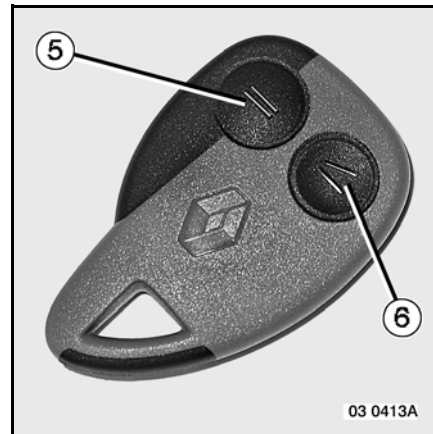

Doors radio-frequency remote control

Depending on your vehicle's equipment

This device does the same job as the door keys. All the doors are locked or unlocked without discrimination by keys or the remote control.

Use

The remote control is powered by a battery (CR 2032-3V) that should be replaced when the actuating range of the remote control becomes reduced.

Unlocking the doors and powering up the vehicle

Press button (6). This action, signalled by the flashing lights flashing, commands:

- powering up the vehicle (for vehicles equipped with an electrical master switch),
- disabling of the engine immobilizer,
- unlocking of the doors.

B1-6 Presentation

Locking of the doors only

Press button (5). This action, signalled by the flashing lights flashing 4 times, commands locking of the doors. The vehicle remains powered up with the engine immobilizer disabled.

Powering down the vehicle

A 2nd press on button (5) less than 10 minutes after the 1st press, signalled by a long flash lasting 1.5 seconds, causes:

- activation of the engine immobilizer,
- opening of the master switch for vehicles equipped with an electrical master switch.



If the flashing lights flash more than 4 times (e.g. after replacing the remote control battery), during the flashing phase, press one of the buttons 2 times to reactivate the remote control.

If the flashing lights do not flash during the locking phase (in spite of the fact that they are working normally), it means that:

- *at least one of the doors is not closed properly,*
- *there is a door locking actuator fault,*
- *there is a receiver fault.*

B1-7 Presentation

Interior and stepwell lighting

The vehicle is provided with 2 overhead lights, one above each of the doors, and 2 stepwell lights.

These lights come on and go out when the doors are opened and closed, when the vehicle is unlocked and locked and when the ignition key is in the "on" position prior to starting.

- When the doors are unlocked by the remote control, the interior lights comes on for a period of 17 seconds.
- When a door is opened, the interior lights stay on or come on again if they have gone out, for a period of 5 minutes (if at least one door remains open beyond that limit).
- After a door is closed, the interior lights stay on for 17 seconds, to give you time to put the key into the ignition switch.
- Switching on the ignition immediately causes the interior lights to go out.
- Stopping the engine causes the interior lights to come on for a period of 17 seconds.
- Locking of the doors causes the interior lights to immediately go out.

The overhead lights can be forced to come on by actuating one of the two switches.

See page(s) B2-74.

B1-8 Presentation

Replacing the battery

Using a screwdriver (1), open the casing in the place marked.

Replace battery (2) complying with the polarity engraved on the cover.

Use an alkaline type battery: **CR 2032-3V**.

The battery service life is about 3 years.

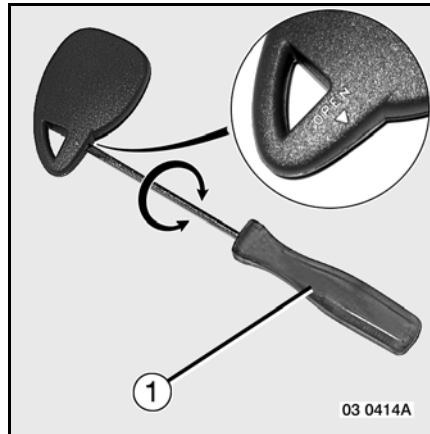

Do not forget to make a note of the number of your keys. If you lose them or would like another set of keys or remote control, contact a RENAULT TRUCKS service point or dealer. Tell him the key numbers and show him the vehicle documents.



B1-9 Presentation

Alarm

Features

- "Panic" button in the event of aggression to the driver.
- Volumetric protection of the cab.
- Perimetric protection of cab doors.
- Cab tilting protection.
- "After ignition positive" protection.
- Protection against disconnection of batteries and disconnection of siren (self-powered siren).
- Alarm activation warning light on the control box.
- A pictogram and a message on the information display and a sound given off by the siren serve to identify the nature of the aggression.



The following features are only possible if the vehicle body and/or the coupled trailer is equipped with the freight protection box distributed by the RENAULT TRUCKS Boutique.

- Perimetric protection of vehicle body and/or trailer doors.
- Surveillance of onboard freight while at a standstill or when moving (opening of doors and unplugging of trailer electrical socket).

"Panic" button

In the event of aggression, press "panic" button (E3) for about 2 seconds to give the alert. The siren sounds immediately and the hazard lights flash. To stop the siren and the hazard lights, press button (E3) again for about 2 seconds.

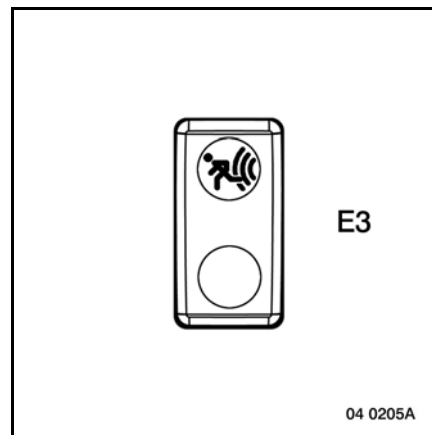

B1-10 Presentation

Activation of the alarm



The alarm is activated and disabled by means of the radio frequency remote control. If the vehicle body and/or trailer are equipped with the freight protection box, it will be automatically taken into account by the central alarm box.

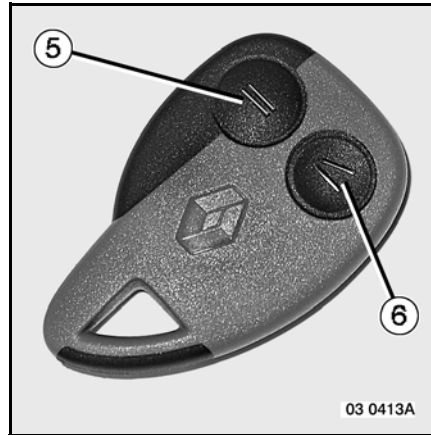

Vehicle powered up (master switch closed): press the remote control button (5):

- The cab doors lock.
- The hazard lights flash 4 times.
- The red LED (4) on the control box (3) flashes - the alarm is activated 10 seconds later.

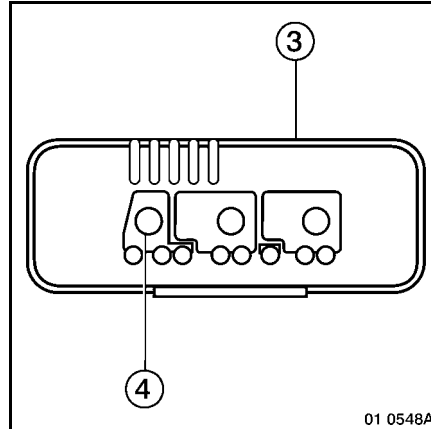

B1-11 Presentation

Control box position (1)

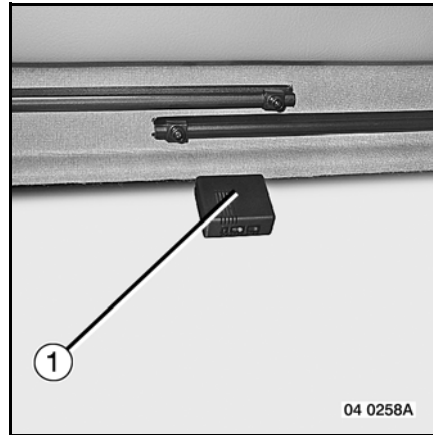

Activation of the alarm without volumetric protection and without cab tilting protection
Vehicle powered up (master switch closed):
Two methods are proposed:
Ignition key in steering lock position (1) or (2).

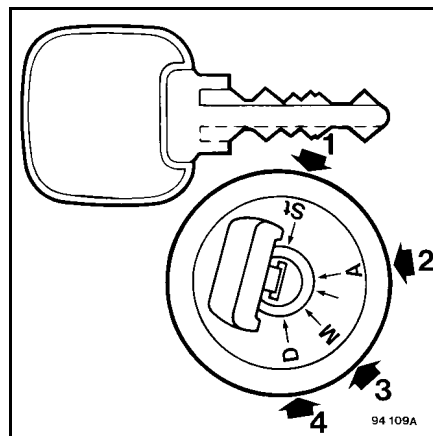

The "volumetric alarm exclusion arm" warning light (E1) is on.

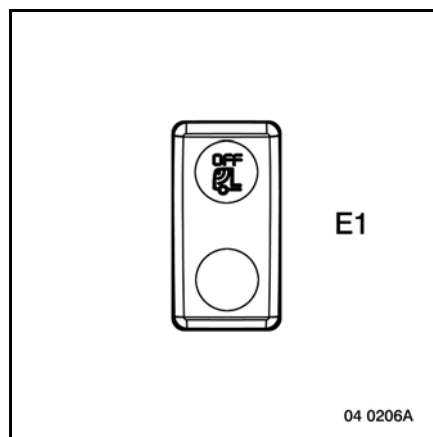

B1-12 Presentation

Press button (5) on the remote control:

- The cab doors lock.
- The warning light on the "volumetric alarm exclusion" switch (E1) goes out,
- The hazard lights flash 4 times.

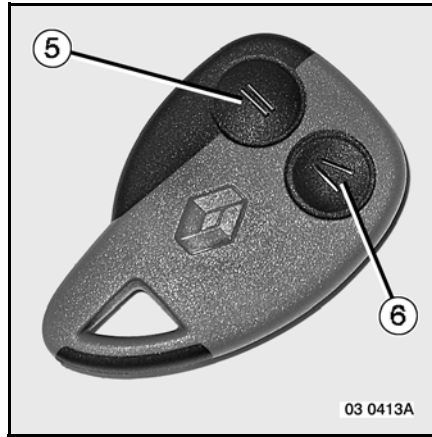

- The red LED (4) on the control box (3) flashes - the alarm is activated 10 seconds later.

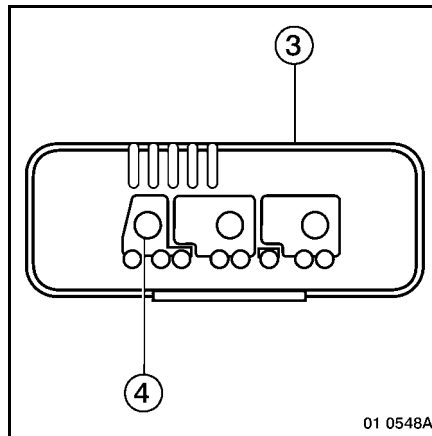

B1-13 Presentation

Ignition key in your possession

- Take the key out of the ignition switch.
- Press "volumetric alarm exclusion" switch (E1), warning light comes on.

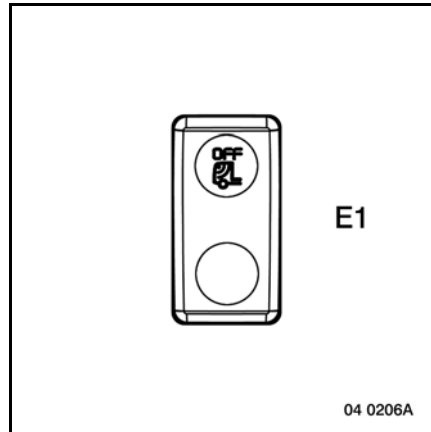

- Press button (5) on the remote control:
 - The warning light on the "volumetric alarm exclusion" switch (E1) goes out.
 - The cab doors lock.
 - The hazard lights flash 4 times.

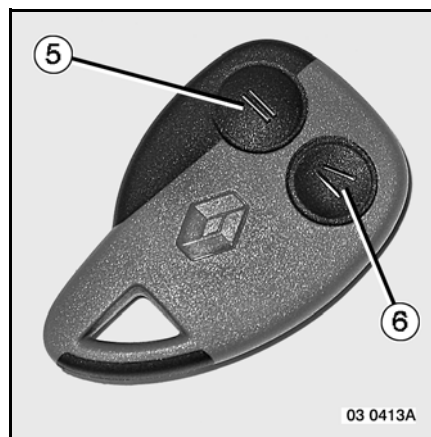

- The red LED (4) on the control box (3) flashes - the alarm is activated 10 seconds later.



When your vehicle is being transported by boat or rail convoy, activate the alarm without volumetric protection and without cab tilting protection to avoid any inadvertent triggering of the alarm.

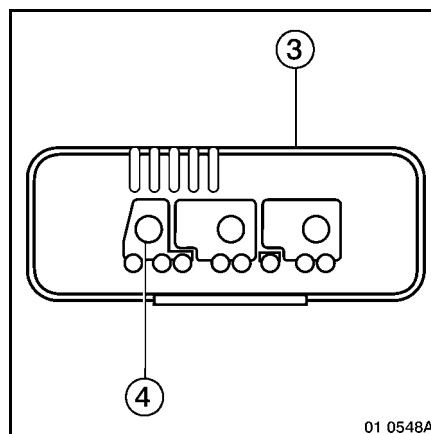

B1-14 Presentation

Fall-back mode

During the 10 seconds necessary to activate the alarm, all the alarm sensors are checked out. If a door has been left open, the siren sounds to draw attention to the problem. After these 10 seconds, the door in question will be excluded and not protected. The fall-back mode can be used while freight is being unloaded.

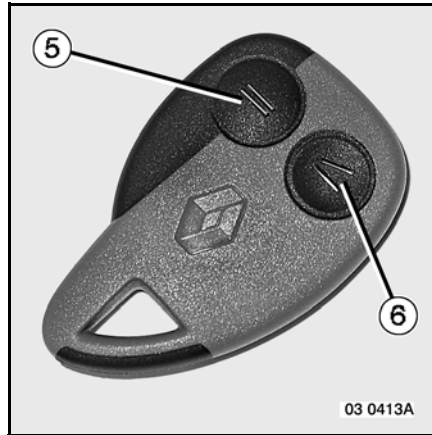

If the door in question is closed after the alarm is activated, it will be locked and protected.

B1-15 Presentation

Disabling of the alarm

With the vehicle powered up, press button (6) on the remote control:

- The vehicle is powered up (only for vehicles equipped with an electrical master switch).
- The cab doors unlock.
- The red LED (4) on the control box (3) goes out.

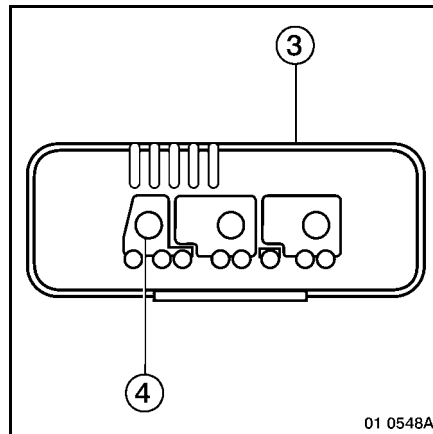

In the event of remote control malfunction, you can disable the alarm by turning the ignition key to the "ignition" position (3). After that, it is necessary to re-synchronize the remote control with the alarm by activating and de-activating the system once more.

If there is an attempt at theft of the vehicle or its freight, the siren sounds after the alarm has been disabled. It is possible to find out what kind of intrusion has been perpetrated by means of the message and the pictogram (G36) shown on the information display.

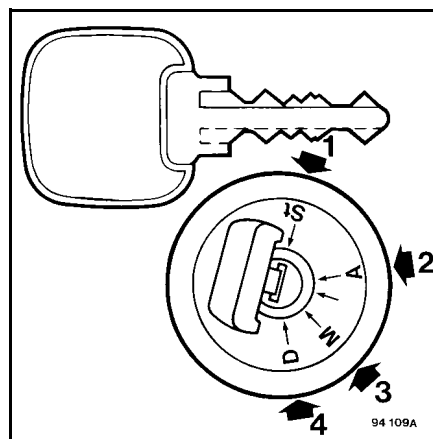

The message and the pictogram are erased when the ignition is switched on, with the ignition key in position (3).

B1-16 Presentation

"Starting impossible"

In the event of transponder malfunction, it is impossible to start the engine. The message **"Starting impossible"** is shown on the information display. Call upon the nearest RENAULT TRUCKS service point or dealer.

Stopping of the alarm without opening the door(s)

If the doors are unlocked and the alarm stops without the doors being opened within a period of 2 minutes, the doors are locked and the alarm is re-activated automatically.

B1-17 Presentation

Front grille

Pull the bottom part of the radiator grille to open it. Push it to close.



WHEN WORKING AT THE FRONT END OF THE VEHICLE WITH THE FRONT GRILLE OPEN, ENSURE THAT THE WINDSCREEN WIPER SWITCH IS IN THE "OFF" POSITION. IT MIGHT PROVE TO BE DANGEROUS IF YOU PLACE YOUR HANDS ON THE SCREEN WIPER LINKAGE. IF POSSIBLE, DISENGAGE THE MASTER SWITCH.

B1-18 Presentation

Side fairings

Opening

Unlock side fairings (1):

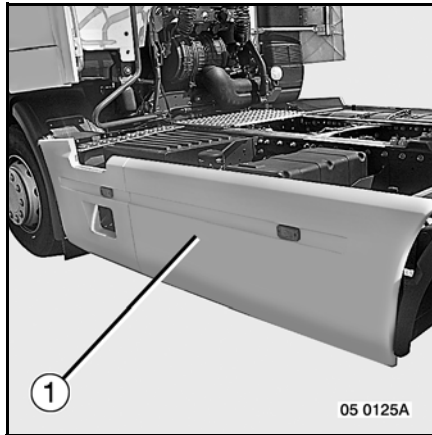

Lift up catches (2), pivot them through 1/4 of a turn, then pull the fairings until they are held by straps (3).

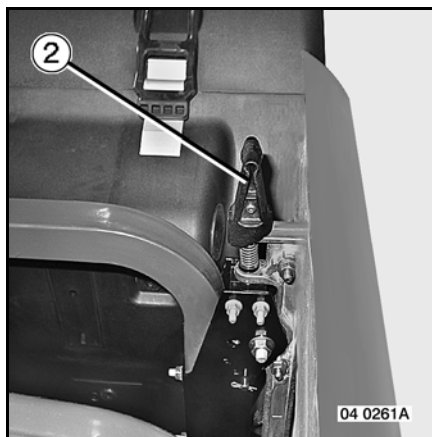
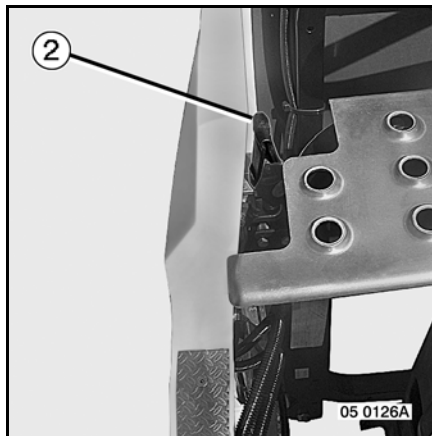

B1-19 Presentation

It is possible to remove the fairings completely by unhooking the holding straps (3) and pulling the fairings towards yourself to dislodge them from the rubber sandwich mountings (4).

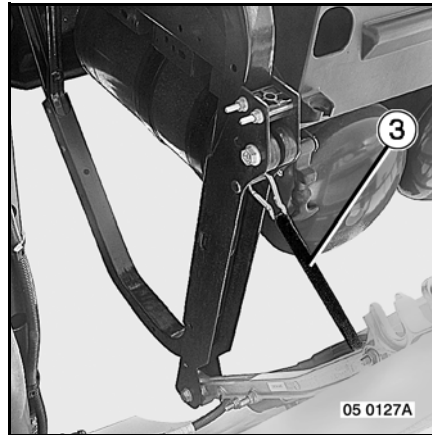

Closing

If the fairings have been removed, fit them into the rubber sandwich mountings (4) by pushing them at the bottom and fasten the strap snap hooks (3).

Push the side fairings (1), pivot the catches (2) through 1/4 of a turn.

Ensure that the fairings are correctly locked.

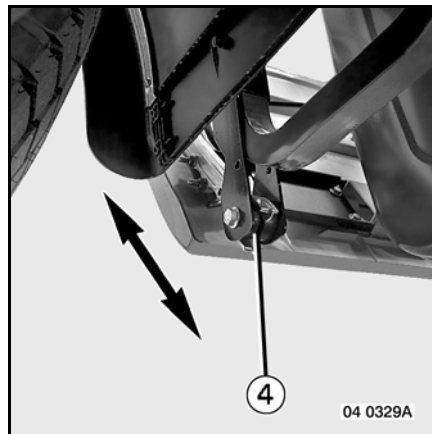

B1-20 Presentation

Cab tilting



NEVER TILT THE CAB WHILE THE ENGINE IS RUNNING.

Before restarting the engine, check:

- Cab raised: that the gear lever is in neutral.
- Cab lowered: that the gearshift linkage is locked, after checking that all gears shift correctly.

When working underneath the cab (on the engine, etc...), the cab must be fully tilted.

Any work on the cab tilt hydraulic system requires strict observance of the safety instructions and should therefore be carried out by a RENAULT TRUCKS service point or dealer.

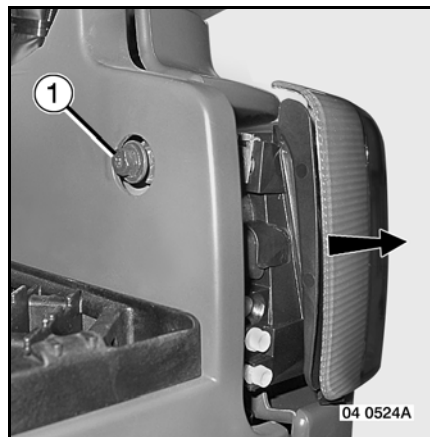

Cab tilting hydraulic system

Filling and checking oil level

With the cab in the "road" position, fill with oil through oil reservoir filler port (2).

To gain access to the oil reservoir, slacken screw (1) and pivot the headlamp insert.

Check the oil level: the oil should be flush with the top of piston (3) when it is in the "down" position.

Carefully carry out one complete tilting manoeuvre (up and down), then check the oil level again. In the event of malfunction, consult a RENAULT TRUCKS service point or dealer.

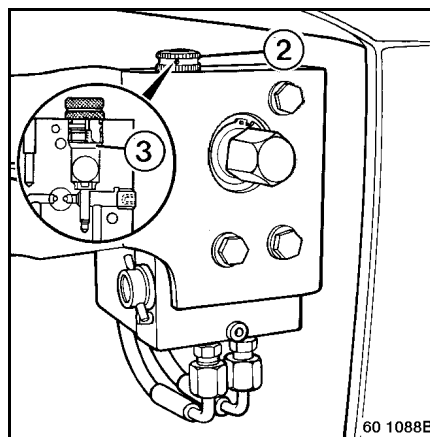

B1-21 Presentation

Depending on your vehicle's equipment

Before tilting the cab:

- Lock the storage compartments.
- Empty the bottle-holder.
- Stop the refrigerator.

Depending on your vehicle's equipment

Mechanical control

With the vehicle stationary, engine shut down, gear lever in neutral, doors properly closed, make sure that no loose articles in the cab can be thrown against the windscreen. Clear the area in front of the cab. Place lever (1) in the "up" position. Use operating bar (2).

Since unlocking is automatic, pump until the cab tilts fully. Use jack handle (3) to add leverage to the operating bar (2). Force the operating bar fully downwards.

To return the cab to the "road" position, place lever (1) in the "down" position, pump until the cab locks automatically.

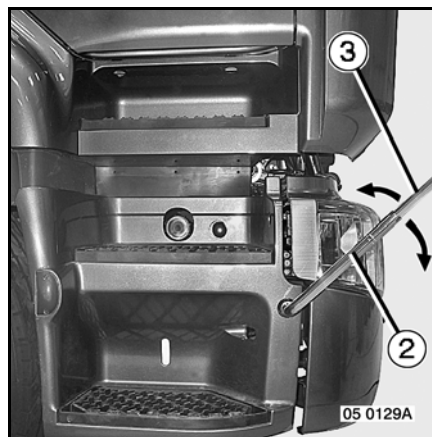
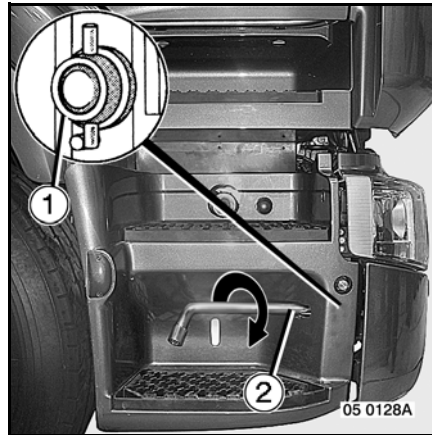

If you experience difficulty in tilting, return the cab to the "road" position and check the oil level. Top up with oil, if necessary.

Carefully carry out one complete tilting manoeuvre (up and down), then check the oil level again. In the event of malfunction, consult a RENAULT TRUCKS service point or dealer.

It is impossible to open the front grille when the cab is tilted.

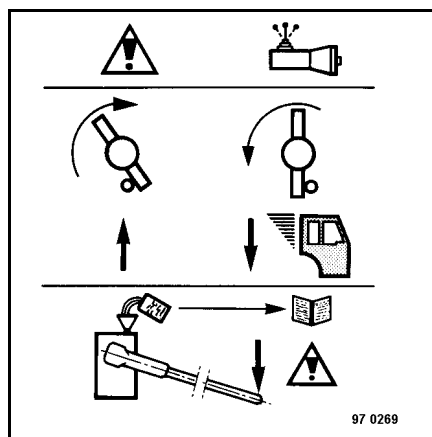

B1-22 Presentation

Depending on your vehicle's equipment

Electrical control

Depending on the assembly, the mechanical control is assisted by an electrical control. Place lever (1) in the "up" position. Use operating bar (2).

With the ignition switched on, press button (4). Since unlocking is automatic, pump until the cab tilts fully.

To return the cab to the "road" position, place lever (1) in the "down" position, press button (4) until the cab locks automatically. **Do not leave your hands on the step during the manoeuvre.**

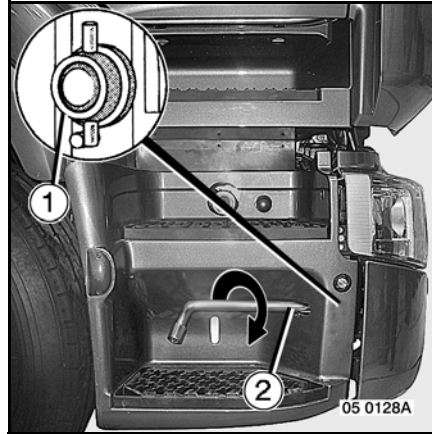

After 2 successive tilting manoeuvres (up and down), wait for 15 minutes for the pump motor to cool down before starting again.

If you experience difficulty in tilting, return the cab to the "road" position and check the oil level.

In the event of electrical failure (control or pump), use the mechanical cab tilt control.

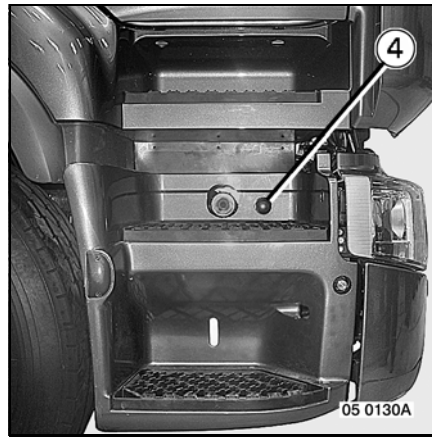
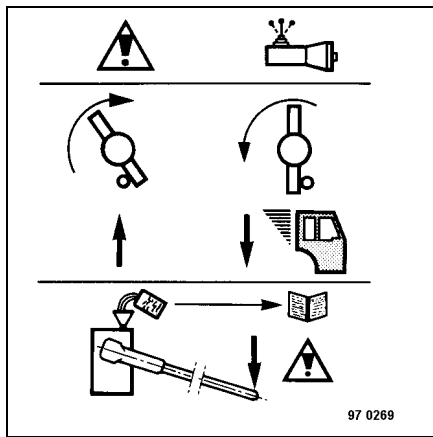

B1-23 Presentation

External storage locker(s)

Depending on your vehicle's equipment

Opening and closing of compartment (1) with handle (2). Locking with key lock.

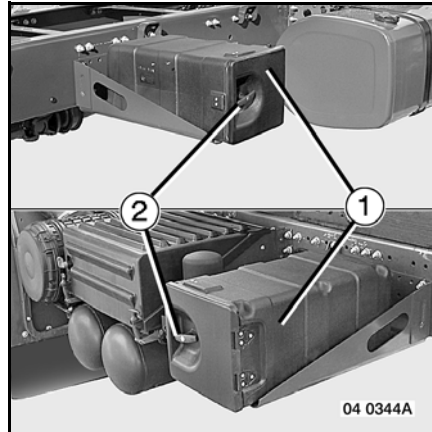

Opening and closing of compartment (1) with handle (2). Locking with key lock.

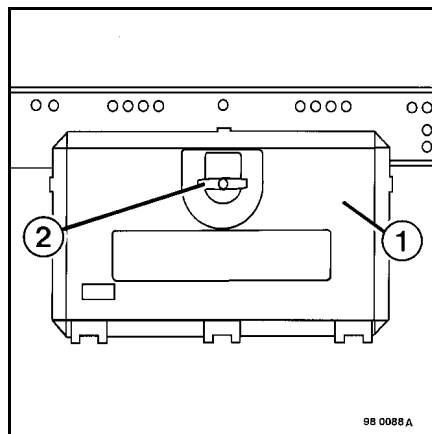

B1-24 Presentation

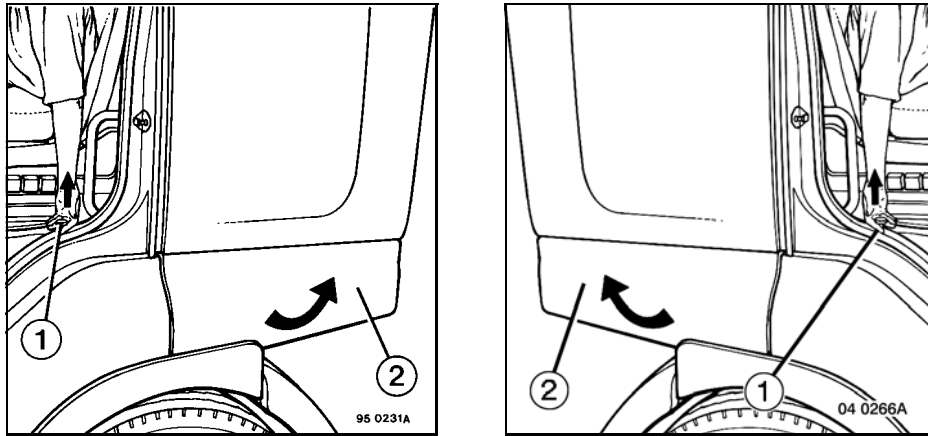

Opening: Pull control (1) to unlock the door. Lift up door (2). There is a strut to hold the door open.

A light fitted with a switch comes on when the master switch is engaged.

Closing: Push control (1) free the strut and close door (2). Locking is automatic.

The tool locker under the cab is not provided with a strut. It is held open by a hard spot that has to be overcome when closing.

B1-25 Presentation

Fuel tank(s)

Fuel filler cap

The filler cap is locked by a key lock (1).

Vehicle equipped with two fuel tanks without changeover valve

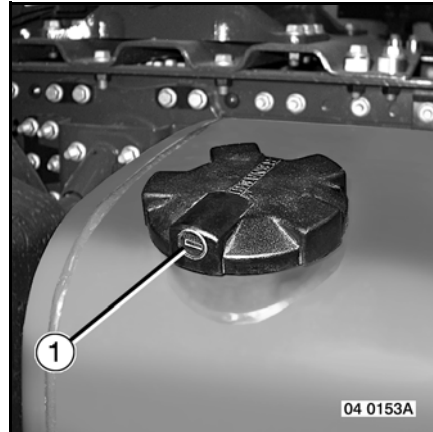

Since there is no fuel gauge switch, the fuel level gauge shows the total contents of both fuel tanks.



When filling up with fuel, you are recommended to put fuel into both tanks.

Depending on your vehicle's equipment



SWITCH OFF THE INDEPENDENT HEATER BEFORE YOU FILL THE FUEL TANK(S).

B1-26 Presentation

Master switch

Depending on your vehicle's equipment

Turn handle (1) through one quarter of a turn to isolate the electrical installation except for alarm, central door locking, tachograph, independent heating timer and hazard lights.

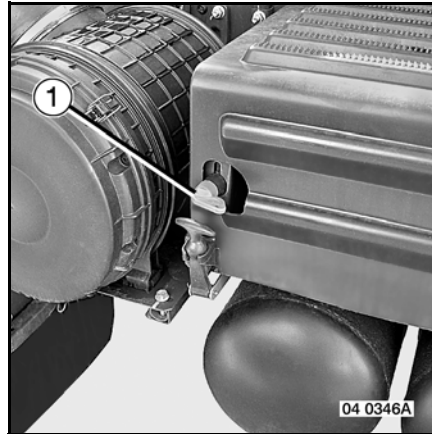

If the vehicle is equipped with a remote control for electrically locking the doors coupled with the master switch control, refer to page B-1-5 on how to use it.

B1-27 Presentation

"ADR" master switch (transport of dangerous materials)

Use of the ADR battery isolating switch

Several parameters are involved:

- ignition key inserted in ignition switch,
- chassis exterior switch,
- cab interior switch,
- following electrical consumers:
 - side/parking lights,
 - hazard lights,
 - suspension,
 - independent heating.

Operation

Cab interior switch (B4)

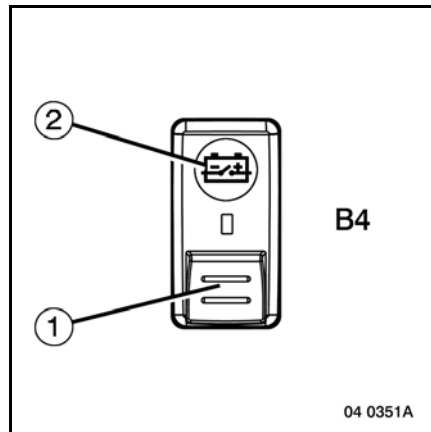

Chassis exterior switch (2)

Switch type operation

The battery isolating switch can be operated by means of switch (B4) or (2).

If either of the two switches is actuated, it is essential for the key to be put back into the ignition switch and for the those switches to be in the "ON" position to close the battery isolating switch.

The "ADR" battery isolating switch serves to supply electrical power to the vehicle if neither of the two switches is actuated by the driver.

If either of the two switches is actuated, the "ADR" battery isolating switch cuts the electrical power supply to the vehicle and the engine stops automatically.

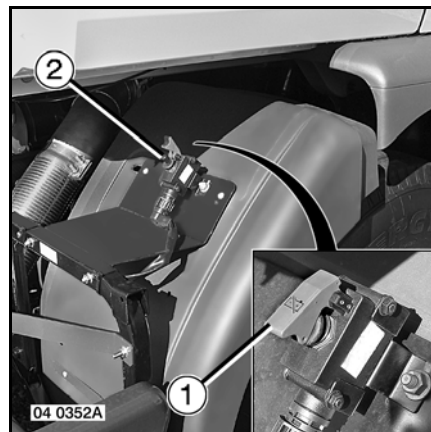

B1-28 Presentation

Operation by insertion of ignition key in ignition switch

With the "ADR" battery isolating switch in the position for supplying electrical power to the vehicle (switches (B4) - (1) not actuated and ignition key inserted in ignition switch); if the driver takes the ignition key out of the ignition switch and if none of the electrical consumers quoted earlier is in operation, the "ADR" battery isolating switch cuts the electrical power supply to the vehicle after a period of 20 minutes.

The electrical power supply will be restored to the vehicle when the ignition key is inserted into the ignition switch. If the driver's door is locked by the door key, unlock it with that key.

Vehicle equipped with independent heating

(See page B2-66).

B2-1 Presentation

Driving position

Seats



For your own safety, it is essential to remove the plastic protective cover when putting the vehicle into commission.

Seat suspension

Adjust the flexibility of the suspension according to the state of the road and the user's weight.

Air-operated seats

Controls will only work if there is sufficient air pressure.

Driver's seat

Passenger(s) seat

Depending on your vehicle's equipment



Depending on seat use (i.e. driver, passenger, left or right hand drive), controls are located to one side or the other. The seat type shown is just one possible solution.

- 1 - "Vertical" Ssuspension "vertical" flexibility adjustment:
 - Upwards: hard suspension.
 - Downwards: supple suspension.
- 2 - Fast suspension lowering.
- 3 - "Lower" lumbar support adjustment control.
- 4 - "Upper" lumbar support adjustment control.
- 5 - Side support adjustment.
- 6 - Heated seat cushion and squab (automatic thermostat-regulated operation).



**FOR SAFETY REASONS, ALL SEAT ADJUSTMENT OPERATIONS MUST BE CARRIED OUT WHEN THE VEHICLE IS AT A STANDSTILL.
WHEN THE VEHICLE IS MOVING, ANY USE OF THE SEATS IN A POSITION OTHER THAN THAT OF "FACING THE ROAD" INVOLVES THE RESPONSIBILITY OF THE USERS.**

B2-2 Presentation

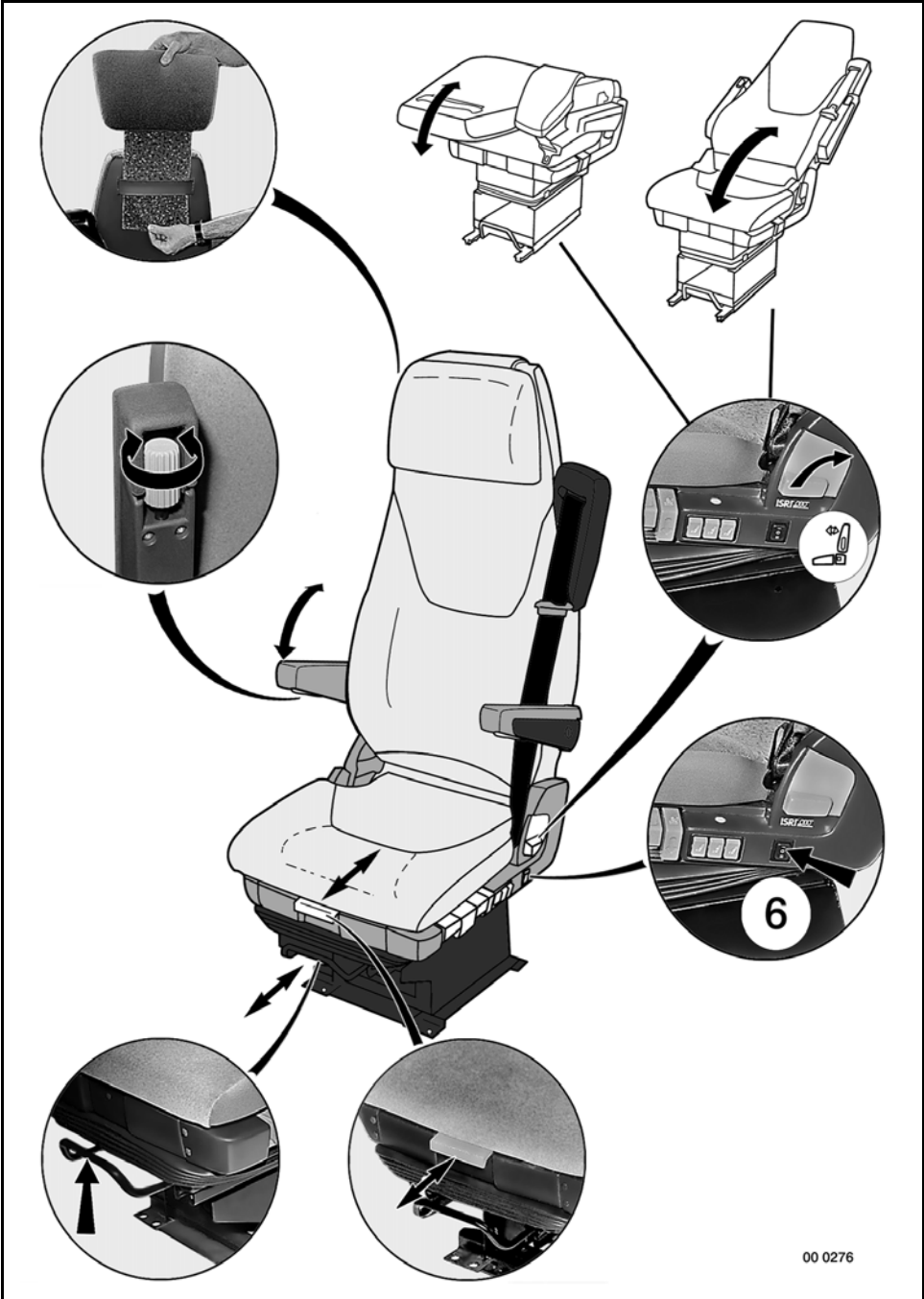

B2-3 Presentation

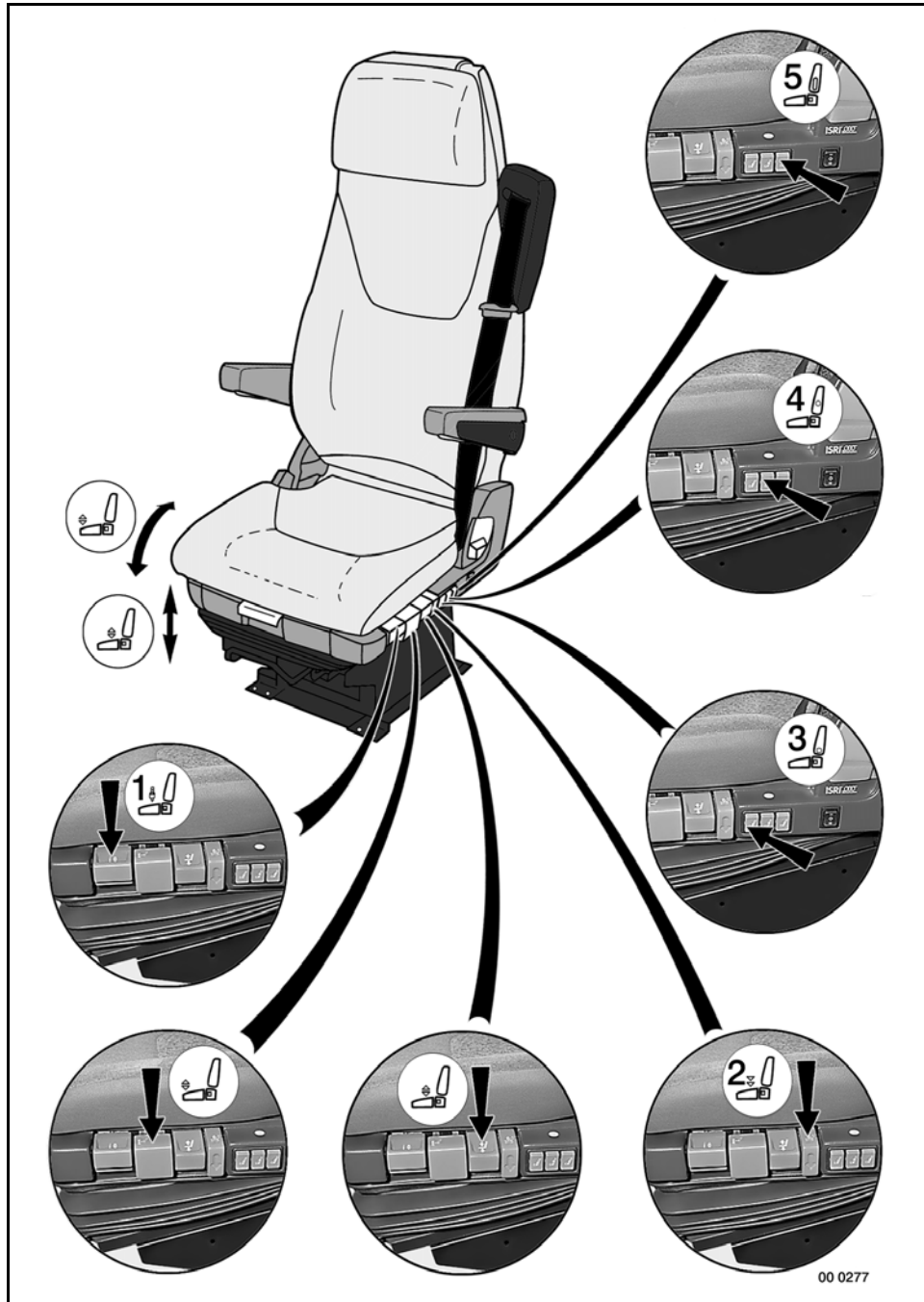

B2-4 Presentation

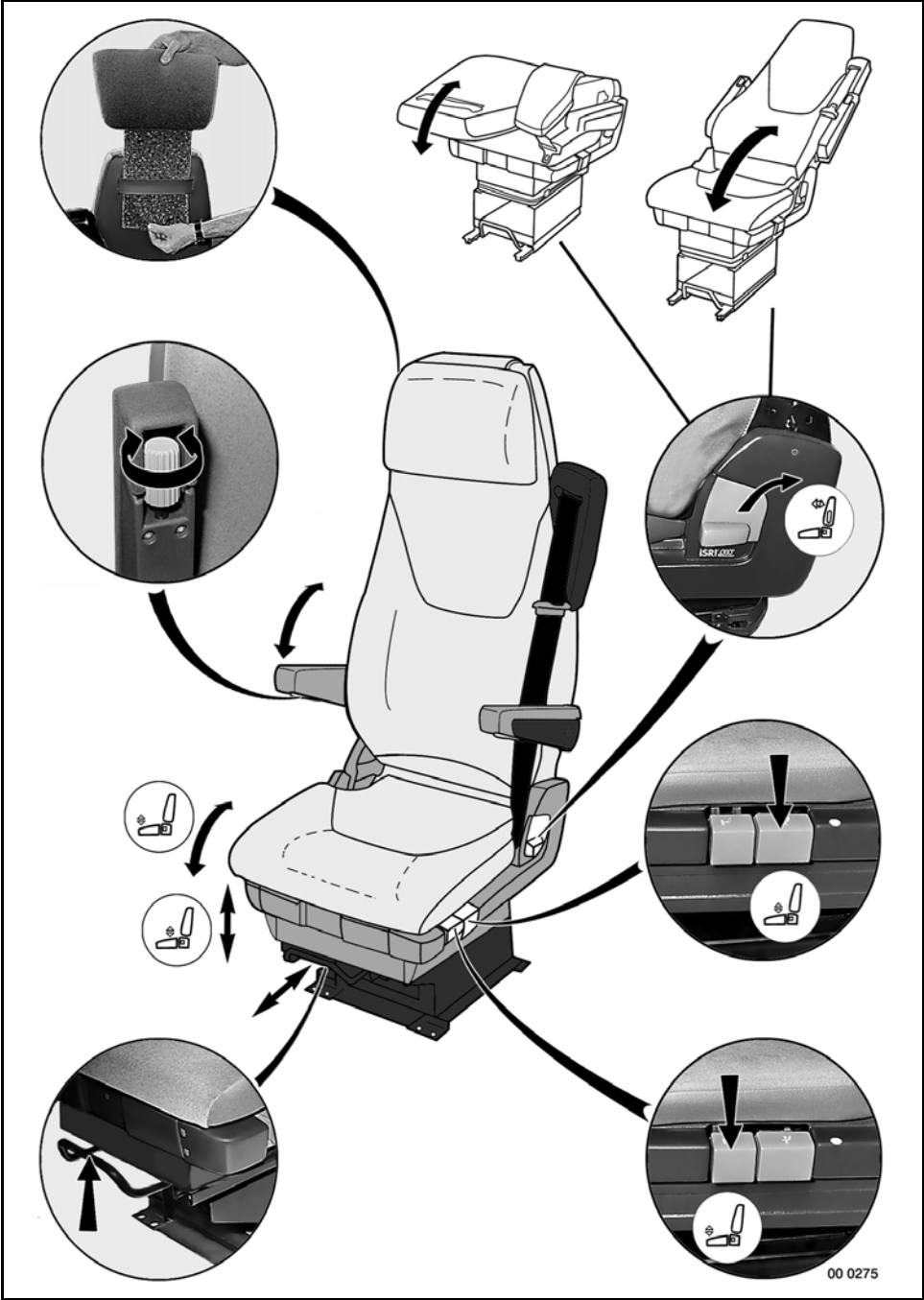

B2-5 Presentation

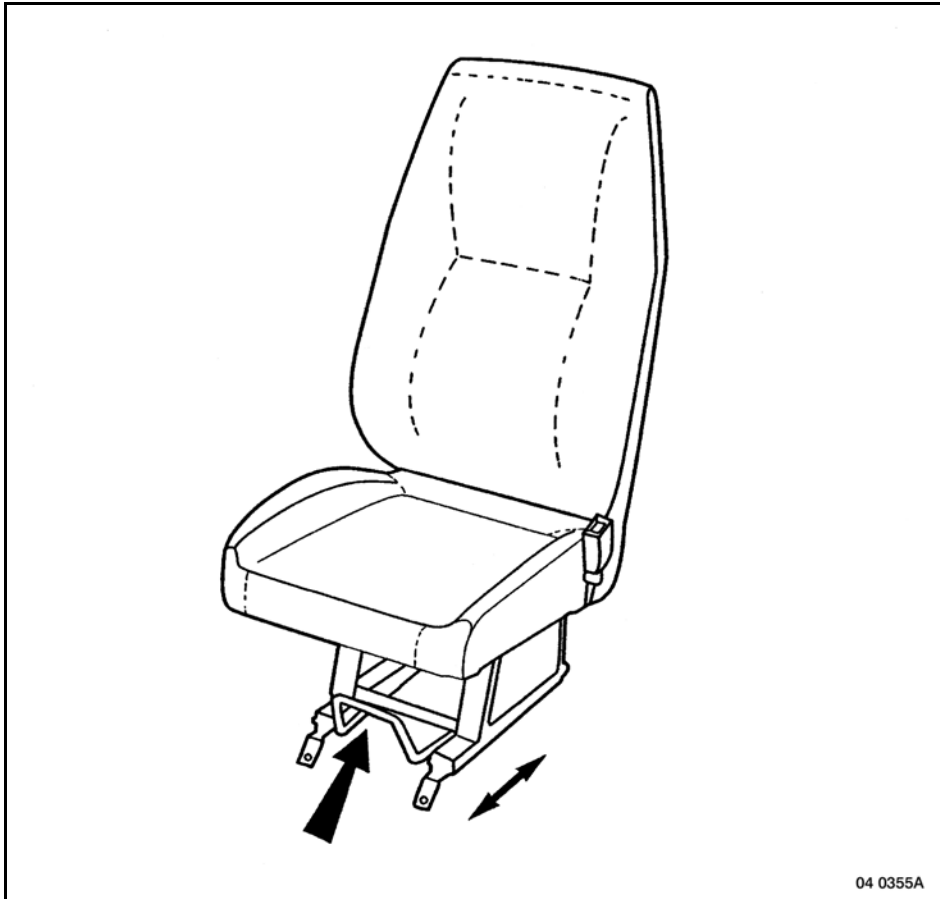

04 0355A

B2-6 Presentation

Dashboard

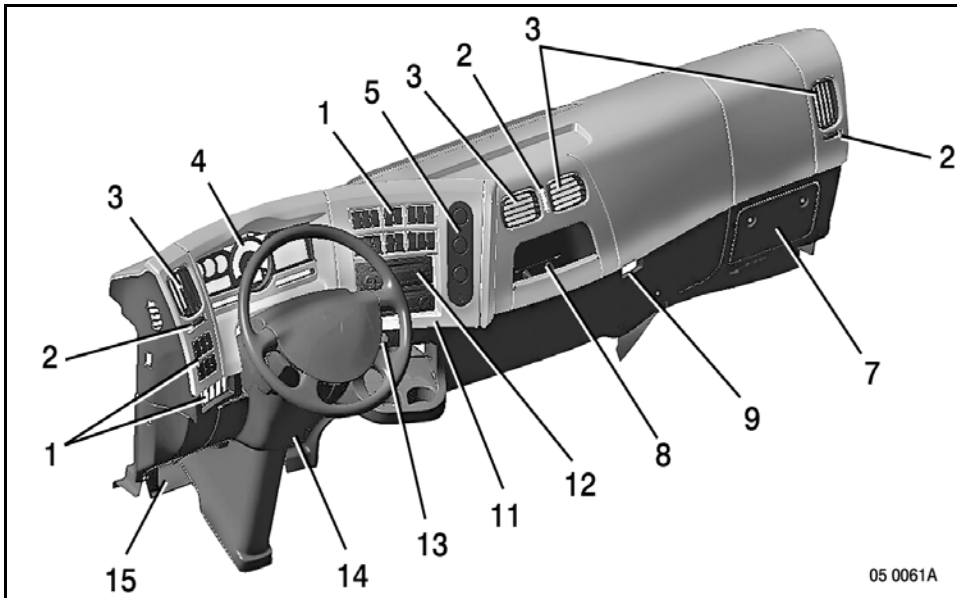
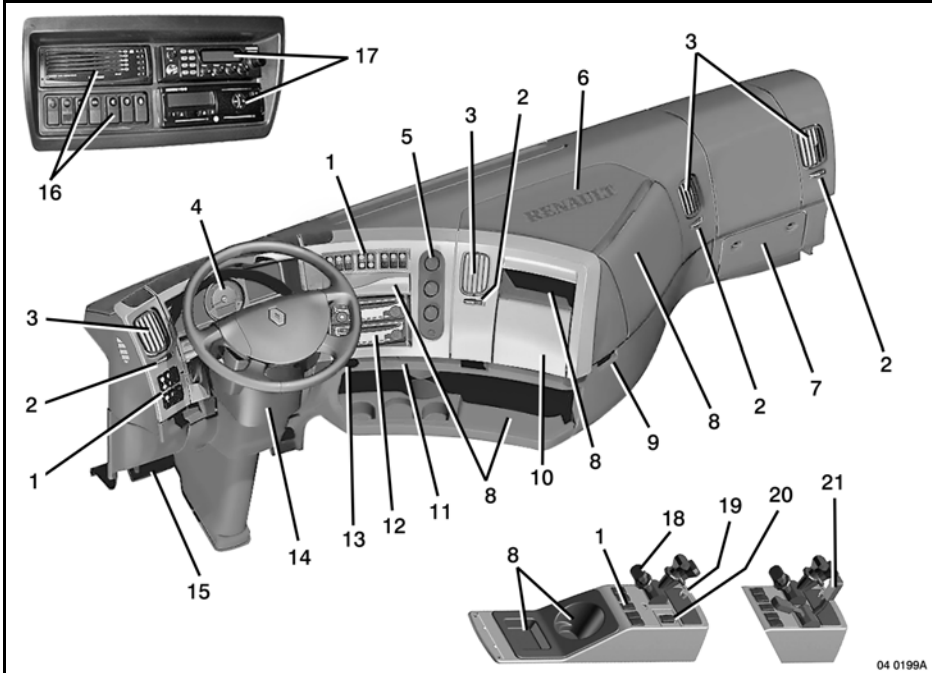

B2-7 Presentation

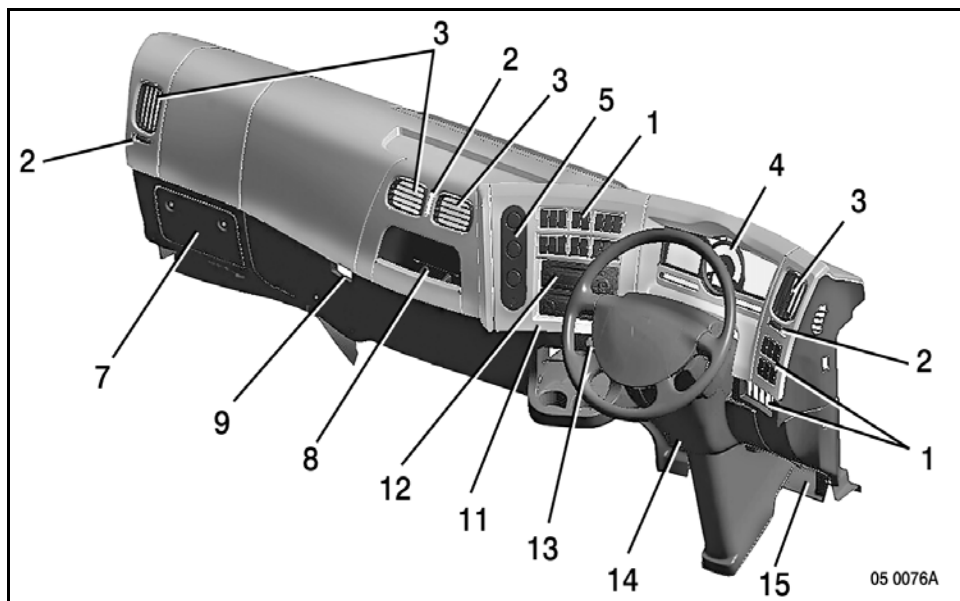
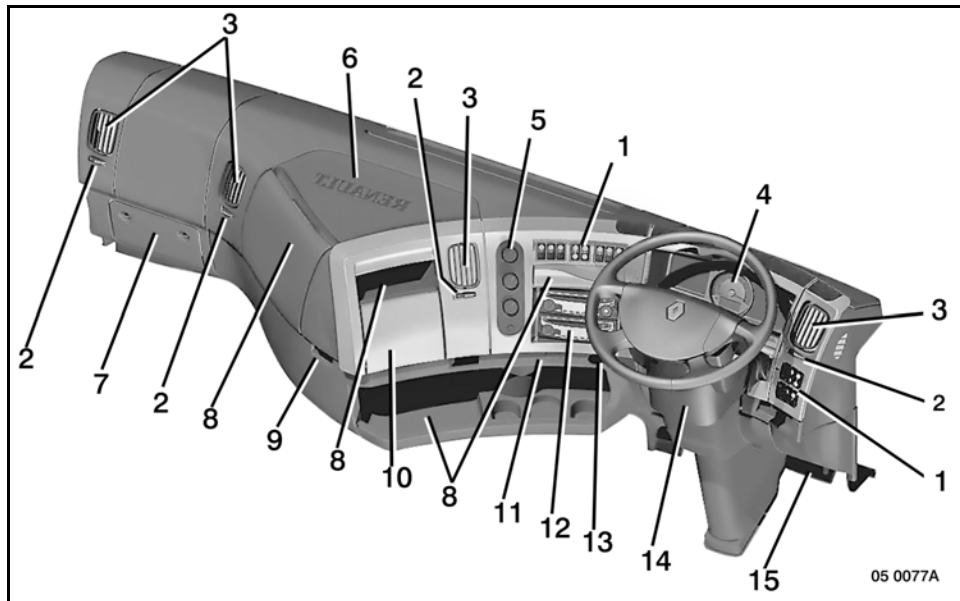

B2-8 Presentation

Depending on your vehicle's equipment

- 1 - Switches (see page B2-24)
- 2 - Air vent(s) control
- 3 - Air vent
- 4 - Information display
- 5 - Thermal comfort panel
- 6 - Ledge with non-slip surface (to be used only when the vehicle is stationary).
- 7 - Fuses
- 8 - Storage spaces
- 9 - Electrical socket 24V (360W maxi)
- 10 - Storage drawer / modular space
- 11 - Electrical socket 12V (120W maxi)
- 12 - Modular space (radio)
- 13 - Cigar lighter
- 14 - Steering wheel adjuster
- 15 - Diagnostic socket
- 15 - Infomax socket
- 16 - Switches / modular space
- 17 - Modular space (tachograph)
- 18 - Parking brake control
- 19 - Air blower outlet
- 20 - Static trailer brake
- 21 - Trailer brake

B2-9 Presentation

B2-10 Presentation

Instrument panel

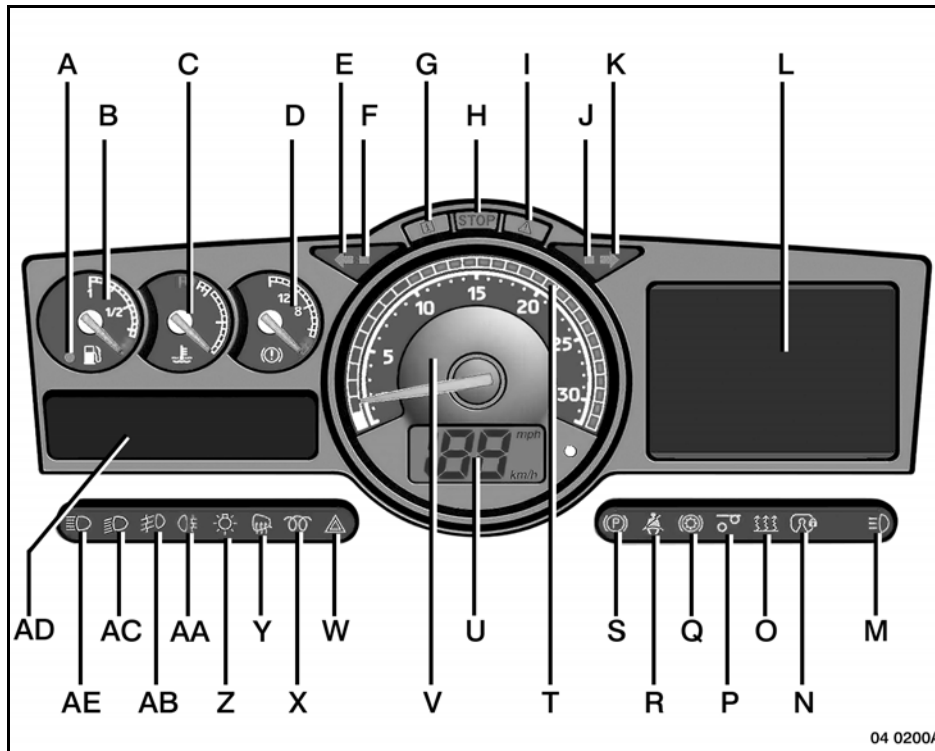

04 0200A

- A - Fuel minimum reserve warning light
- B - Fuel level gauge
- C - Engine cooling system temperature gauge
- D - Air pressure gauge
- E* - Tractor/rigid left-hand direction indicators warning light
- F** - Trailer left-hand direction indicators warning light
- G - "INFORMATION" tell-tale light indicating that a new message has appeared on the multi-function information display (see page B2-28)
- H - Immediate stop "DANGER" warning light
- I - "SERVICE" warning light: Make your way to the nearest RENAULT TRUCKS service point or dealer
- J** - Trailer right-hand direction indicators warning light
- K* - Tractor/rigid right-hand direction indicators warning light
- L - Multi-function information display (see page B2-28)

B2-11 Presentation

- M - Long range driving lights warning light
- N - Not used
- O - Independent heating in service warning light (see page B2-61)
- P - Lift-up axle warning light
- Q - Retarder(s) in service warning light
- R - "SEAT BELT NOT BUCKLED" warning light
- S - Parking brake warning light
- T - Engine speed operating zone (see page C4-2)
- U - Speedometer
- V - Rev counter
- W - Hazard lights warning light
- X - Preheating warning light
- Y - Windscreen defrosting warning light
- Z - Not used
- AA - Rear fog lights warning light
- AB - Fog driving lights warning light
- AC - Dipped beam headlights warning light
 - Comfort information display:
- AD
 - Clock
 - Outside temperature gauge
 - Onboard radio
- AE - Main beam headlights warning light

B2-12 Presentation

Operation of direction indicator lights warning lights

Without trailer

As soon as a direction indicator or hazard lights control is activated, warning light (E) or (K) should flash and the clicker should sound. If they are inoperative, one of the tractor bulbs is defective.

** With trailer

As soon as a direction indicator or hazard lights control is activated, warning lights (E - F) or (K - J) should flash and the clicker should sound.

If warning light (E) or (K) should flash and the clicker should sound. If they are inoperative, one of the tractor bulbs is defective.

If warning light (F) or (J) is inoperative, one of the trailer bulbs is defective.

If the clicker is inoperative, there is a fault both on the tractor and on the trailer.

B2-13 Presentation

Tachograph



To avoid damage to the tachograph, carefully read the manufacturer's instruction book supplied with your vehicle's onboard documents.

If warning pictogram (G61) is displayed, make sure that:

Analogue tachograph

- the tachograph chart is in place in the tachograph unit.

Digital tachograph

- the driver's tachograph chart (1) is in place in the tachograph tray.

If this is not the case, make your way to the nearest RENAULT TRUCKS service point or dealer as quickly as possible to get the repair carried out.

Digital tachograph



To insert and eject the tachograph chart (1) into and from the tachograph chart tray, the vehicle must be at a standstill and the ignition switched on. Upon opening of the tray, the driving time and rest time information shown on the multi-function display is automatically zeroed.

Upon insertion of the driver's tachograph chart, the driving help information previously recorded on the chart is shown on the multi-function display after a few minutes.

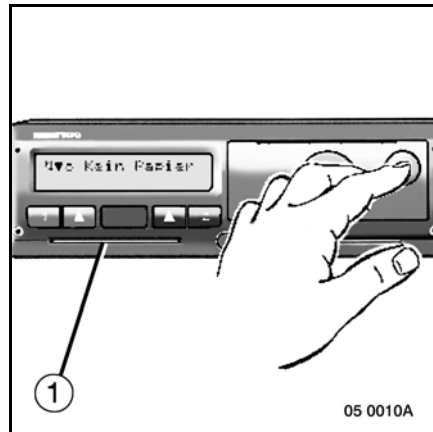

While the data is being loaded from the driver's chart to the tachograph, it is possible to select an activity and move away.

B2-14 Presentation

Insertion of the paper roll



This operation must be carried out with the vehicle at a standstill and the ignition switched on.

Press key (1) to open the printer tray.

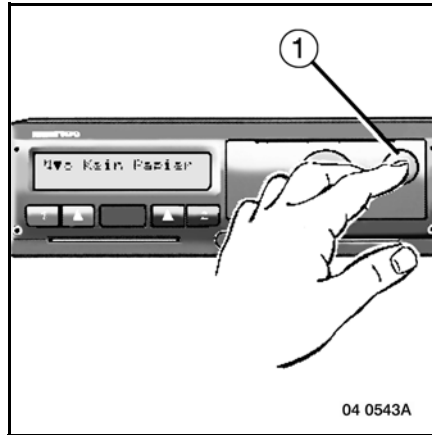

DEPENDING ON THE AMOUNT OF CHARTS PRINTED, THE HEAD OF THE THERMAL PRINTER MAY BE VERY HOT AND THERE IS A RISK OF BURNING YOUR FINGERS.

Take the old paper roll out of the printer tray.
Insert the new paper roll into the printer tray (see illustration).
See that the end of the paper roll (2) overlaps the edge of the tray.
Press the front middle of the printer tray to close.
The printer feeds the paper through automatically.

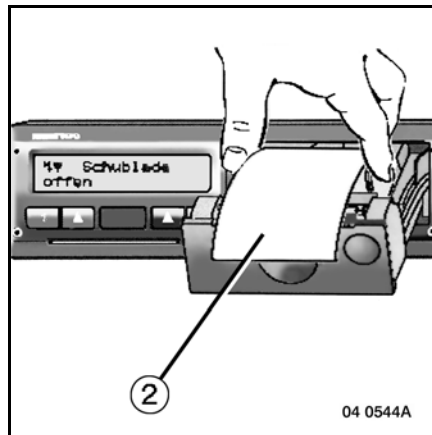

Only paper rolls bearing the following indications may be used:

- type approval sign "e1 84",
- official approval sign "e1 174".

B2-15 Presentation



ENSURE THE PRINTER TRAY IS ALWAYS KEPT CLOSED TO AVOID RISKS OF CUTTING YOURSELF ON THE SHARP CUT EDGE OF THE PAPER.

Analogue tachograph



To open the tachograph chart tray, the vehicle must be at a standstill and the ignition switched on. Upon opening the tray, the driving time and rest time information shown on the multi-function display is automatically reset to zero.

The multi-function information display (L) indicates the activity of driver (1) depending on the tachograph selection made.

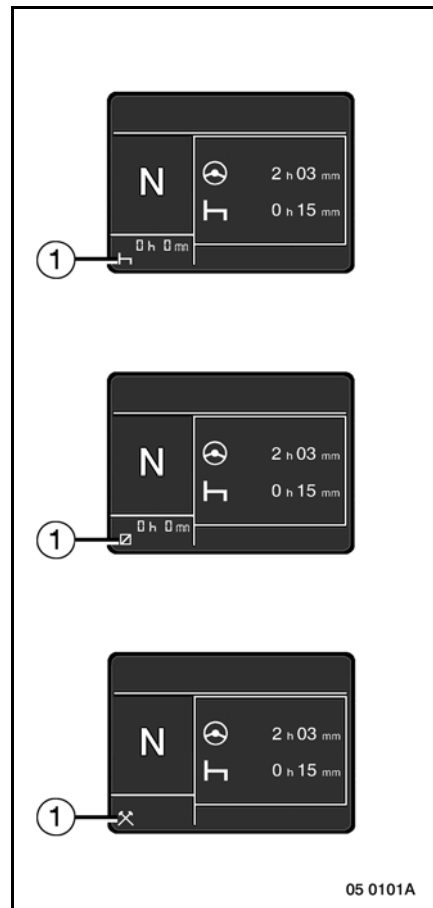

B2-16 Presentation

Key to warning pictograms

Depending on your vehicle's equipment

A text indicating the procedure to be followed or an information message is displayed below the warning pictogram.

These warning pictograms are shown in the multi-function information display.



G1 - Driver information warning pictogram



G2 - Information display fault warning pictogram



G3 - Batteries warning pictogram
- Batteries charging fault warning pictogram



G4 - Engine oil pressure "Alert" warning pictogram



G5 - Engine oil temperature "ALERT" warning pictogram



G6 - Engine oil level "ALERT" warning pictogram



G7 - Engine oil level "OK" warning pictogram



G8 - Engine oil level information loss warning pictogram



G9 - Vehicle electronic fault warning pictogram
- Bodybuilder box fault warning pictogram



G10 - CAN bus link fault warning pictogram

B2-17 Presentation



G11 - Unknown electronic box warning pictogram



G12 - Engine electronic fault warning pictogram
- Air preheating "ALERT" warning pictogram



G13 - Air minimum pressure "ALERT" warning pictogram
- EBS fault warning pictogram



G14 - Trailer "ABS/EBS" warning pictogram:
- small pictogram: check-out of device upon ignition switch-on (no fault)
- large pictogram: device fault "Information"



G15 - Tractor "ABS/EBS" warning pictogram:
- small pictogram: check-out of device upon ignition switch-on (no fault)
- large pictogram: device fault "Information"



G16 - Brake pads wear warning pictogram



G17 - Brakes high temperature warning pictogram



G18 - Air management fault warning pictogram



G19 - Parking brake not applied upon opening of driver's door warning pictogram



G20 - Hill-start assist warning pictogram



G21 - Lighting fault warning pictogram



G22 - Water in fuel warning pictogram



G23 - Fuel pressure trouble warning pictogram

B2-18 Presentation



G24 - Fuel bleeding in progress warning pictogram



G25 - Driver's presence warning pictogram: brake or accelerator pedal depressed



G26 - Clutch overheating warning pictogram



G27 - Fleet management fault warning pictogram



G28 - Maintenance alert warning pictogram



G29 - Electronic air suspension "ALERT" warning pictogram



G30 - Engine cooling system temperature "ALERT" warning pictogram



G31 - Engine coolant low level warning pictogram



G32 - Air filter and/or fuel filter clogging warning pictogram



G33 - Gearbox fault warning pictogram



G34 - Piloted starter trouble warning pictogram



G35 - Electronic engine immobilizer fault warning pictogram



G36 - Alarm warning pictogram

B2-19 Presentation



G37 - Engine overspeed warning pictogram



G38 - Retarder fault warning pictogram



G39 - Cruise control in service warning pictogram



G40 - Not used



G41 - Gearbox PTOs in service warning pictogram
Item numbers (1-2-3) are displayed according to the PTOs engaged.



G42 - PTO maximum speed warning pictogram



G43 - PTO minimum speed warning pictogram



G44 - Inter-wheel diff. lock in service warning pictogram



G44 - Inter-wheel diff. lock in service warning pictogram



G45 - Wheel slip or "ASR" in service warning pictogram
- "ASR" threshold change warning pictogram



G46 - "ASR" disconnected warning pictogram (roller bench testing)



G47 - Electronic air suspension "INFORMATION" warning pictogram



G48 - Axle load-shedding "INFORMATION" warning pictogram

B2-20 **Presentation**



G49 - Revolving beacons in service warning pictogram



G50 - Working spotlight warning pictogram



G51 - Cab tilting trouble warning pictogram



G52 - Screen wash reservoir level warning pictogram



G53 - Message received warning pictogram (fleet management)



G74 - Information pictogram: vehicle equipped with an ESP system



G75 - ESP calibration mode warning pictogram



G76 - Anti-tipover device in service warning pictogram



G77 - ASR in service warning pictogram

B2-21 Presentation

Key to "gearbox" warning pictograms

Depending on your vehicle's equipment



G54 - OPTIDRIVER 2 warning pictogram: move lever to position (D)



G55 - OPTIDRIVER 2 warning pictogram: move lever to position (N)



G56 - OPTIDRIVER 2 warning pictogram: integral automatic mode



G57 - OPTIDRIVER 2 warning pictogram: full-time or part-time manual mode



G58 - OPTIDRIVER 2 warning pictogram: maximum vehicle mobility



G59 - OPTIDRIVER 2 warning pictogram: use brakes or retarders



G60 - Gearbox splitter fault warning pictogram

B2-22 Presentation

Key to "tachograph" warning pictograms

Depending on your vehicle's equipment



G61 - Tachograph fault warning pictogram
- Driving style information pictogram



G62 - Cumulated driving time indication pictogram



G63 - Cumulated rest time indication pictogram



G64 - Rest in progress indication pictogram



G65 - Availability time indication pictogram



G66 - Working time indication pictogram

B2-23 Presentation

Key to "bodybuilder equipment" information pictograms

Depending on your vehicle's equipment



G67 - Body interior lighting tell-tale pictogram



G68 - Bodybuilder system unlock tell-tale pictogram



G69 - Bodybuilder system active tell-tale pictogram



G70 - Tail-lift in dangerous position warning pictogram



G71 - Tipper in working position warning pictogram



G72 - Crane deployed warning pictogram



G73 - Sideboard open warning pictogram

B2-24 Presentation

Key to switches Dashboard

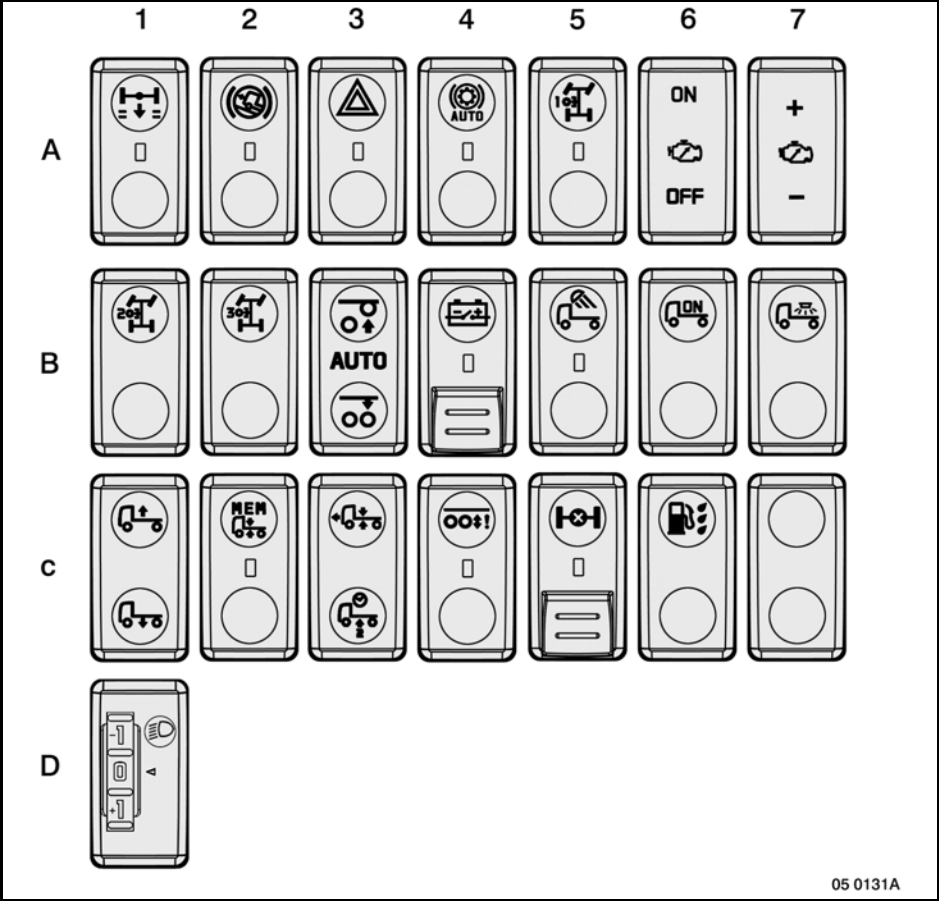

B2-25 Presentation

Depending on your vehicle's equipment

- A1 - "ASR" control switch
- A2 - Hill-start assist control switch
- A3 - Hazard lights control (see page C-4-46)
- A4 - Retarder control switch (manual / automatic)
- A5 - Power take-off control switch
- A6 - Fast idling ON/OFF control
- A7 - Fast idling engine speed regulator ON/OFF control
- B1 - Additional PTO control switch
- B2 - Engine PTO control
- B3 - Lift-up axle control switch
- B4 - Master switch cut-off control switch (ADR)
- B5 - Working spotlight control switch
- B6 - Bodybuilder's equipment control switch
- B7 - Bodybuilder's lighting control switch
- C1 - Suspension "RAISE / LOWER" control
- C2 - "MEMORIZE / RECALL MEMORIZED SETTING" control
- C3 - "RETURN TO ROAD POSITION / STANDBY" control
- C4 - Axle load-shedding control switch
- C5 - Inter-wheel diff. lock control switch (4x2 - 6x2)
- C6 - Bleed water from fuel control
- C7 - Blanking plug
- D1 - Headlights beam height adjustment control

B2-26 Presentation

Ledge

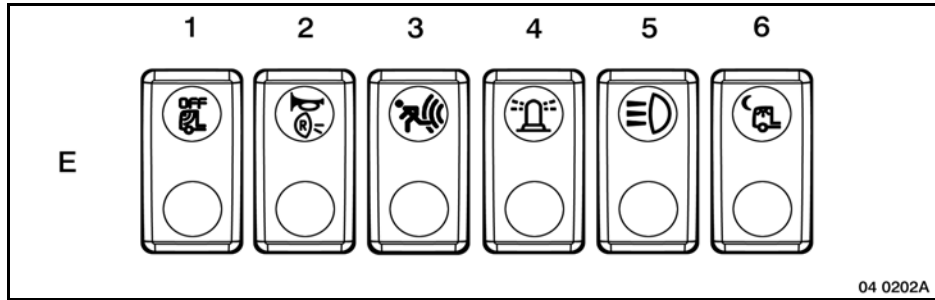

- E1 - Volumetric alarm exclusion control switch
- E2 - Reversing buzzer control switch
- E3 - "PANIC" alarm control switch
- E4 - Revolving beacon switch
- E5 - Extra lights control
- E6 - Red interior lighting control

B2-27 Presentation

Engine tunnel console

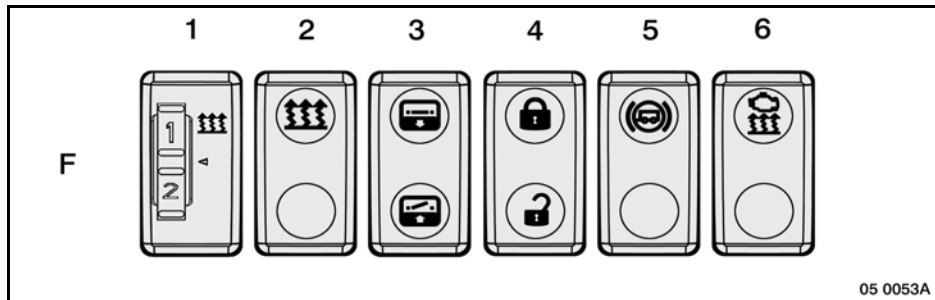

- F1 - Independent heating rheostat
- F2 - Independent heating control switch
- F3 - Sun-roof control switch
- F4 - Central doors locking control switch
- F5 - Trailer brake control switch
- F6 - Air/water independent heating by-pass control

B2-28 Presentation

Multi-function information display

Description:

The multi-function information display is divided into 5 distinct zones.

Zone (1)

Zone displaying active function pictograms and present faults.

When you activate a new function or if a fault appears on the vehicle, the pictogram symbolizing the function or fault is first of all displayed in zone (2) for 15 seconds. Then, it is displayed in zone (1).

Any action on control (AF) is displayed directly in zone (1).

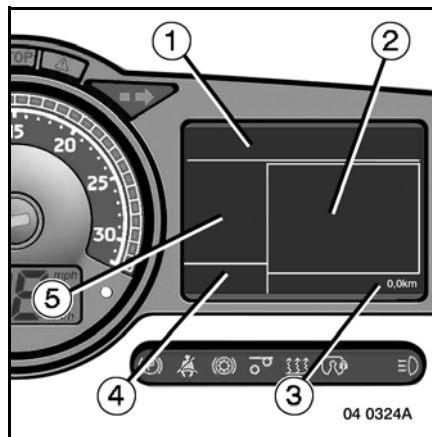

The function pictograms are aligned starting on the left and the fault pictograms are aligned starting on the right.

Zone (2)

This is the main information display zone. Here, the different menus are displayed.

When the ignition is switched on:

- If the engine is not started immediately, the oil level is displayed for a few seconds (see page C-2-2).
- The pictograms connected with the auto-test are displayed for a few seconds (see page C2-5).
- Once the previously mentioned controls have finished their action, the "supplementary driving information" menu is displayed.

When you activate a new function or if a fault appears, the pictogram and the related text are displayed for a moment in this zone, then the active menu before manipulation or appearance of the fault is displayed again. The pictogram is then displayed in zone (1).

Any action on control (AF) is displayed in zone (1).



When zone (1) is full, the following pictograms are displayed in succession every 3 seconds in zone (2).

B2-29 Presentation

Zone (3)

Total mileage (in km).

Zone (4)

When the ignition is switched on:

- information connected with the tachograph.

During driving:

- information connected with the "cruise control" function.

Zone (5)

information connected with the use of the gearbox.

The button (AF) has a different function depending on whether you are in the "SUPPLEMENTARY DRIVING INFORMATION" menu or in one of the other menus or sub-menus.

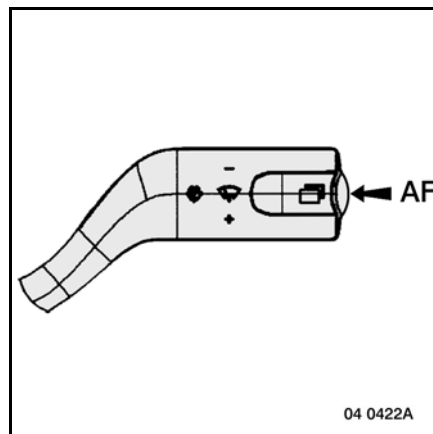

Supplementary "driving information" menu

- Press control (AF) each time to go to the next screen (see page B-2-32).
- When a pictogram appears in display zone (2), press control (AF) to transfer the pictogram to zone (1) without waiting for the end of the time-delay.

Other menus

Press control (AF) to go directly to the "SUPPLEMENTARY DRIVING INFORMATION" menu (**without confirmation**).

B2-30 Presentation

Onboard radio / display remote control

The "RADIO/DISPLAY" remote control, located under the steering wheel, serves to adjust the radio without taking your hands off the steering wheel. It also serves to "navigate" in the different menus of the information display.



IN "DISPLAY" MODE, YOU ARE ADVISED TO USE THE REMOTE CONTROL WHEN THE VEHICLE IS STATIONARY AND CORRECTLY PARKED, FOR SAFETY REASONS.

Functions

- 1- Select stations (radio).
- 2- Go back to menu or previous setting (display).
- 3- Increase radio sound volume / move around in menu.
- 4- Call up main menu / access menu or sub-menu selected / confirm settings (display).
- 5- Reduce radio sound volume / move around in menu.
- 6- Activate automatic station search (radio).
- 7- Scroll through memorized radio stations / scroll through menus.

B2-31 Presentation

B2-32 Presentation

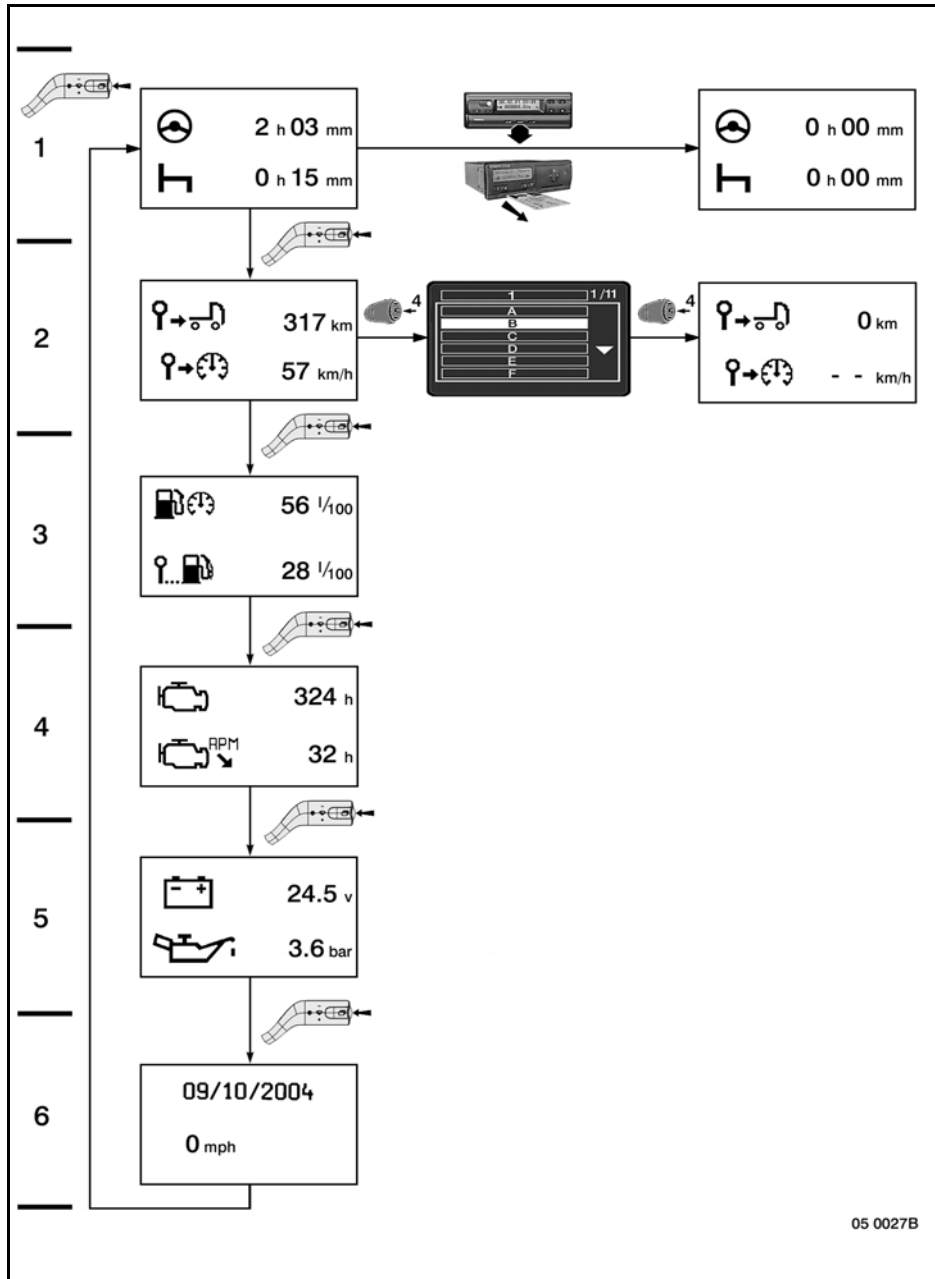

B2-33 Presentation

Supplementary driving information

Using control (AF) (see page B-2-30), it is possible to display different information items in succession, that can amount to 6 in total and vary depending on your vehicle's equipment.

The display of this information is time-delayed when the ignition is switched on, with the engine running or shutdown, and when the vehicle is not moving.

As soon as the vehicle moves off, if you select an information item, it remains permanently displayed.

1- Cumulated driving time.

Cumulated rest time.

The cumulated rest time is incremented after a period of 15 minutes of rest or availability at a stretch.

The cumulated driving time displayed on the instrument panel corresponds to the effective vehicle running time (speed different from 0 km/h).

Brief stops, due to traffic, are automatically deducted.

This information is reset to zero:

- when the tachograph chart tray is closed,
- when driving or working is resumed after 45 minutes of accumulated rest.



The times displayed are given for guidance purposes. Only information recorded on the chart has any legal value.

2- Partial mileage (in km).

Average road speed.

This information is reset to zero by pressing control (AF) and keeping it depressed for more than 15 seconds.

3- Instant fuel consumption in litres per 100 km.

Average fuel consumption in litres per 100 km.

The instant fuel consumption is given for guidance purposes - it may reach substantial proportions during acceleration or when moving off, but it is not significant of the vehicle's average fuel consumption.

4- Total engine operating hourmeter.

Engine operating hourmeter with vehicle stationary.

5- Battery voltage.

Engine oil pressure.

6- Date.

Vehicle road speed in the unit you have not chosen for the instrument panel speedometer (U) (mph or km/h).

B2-34 Presentation

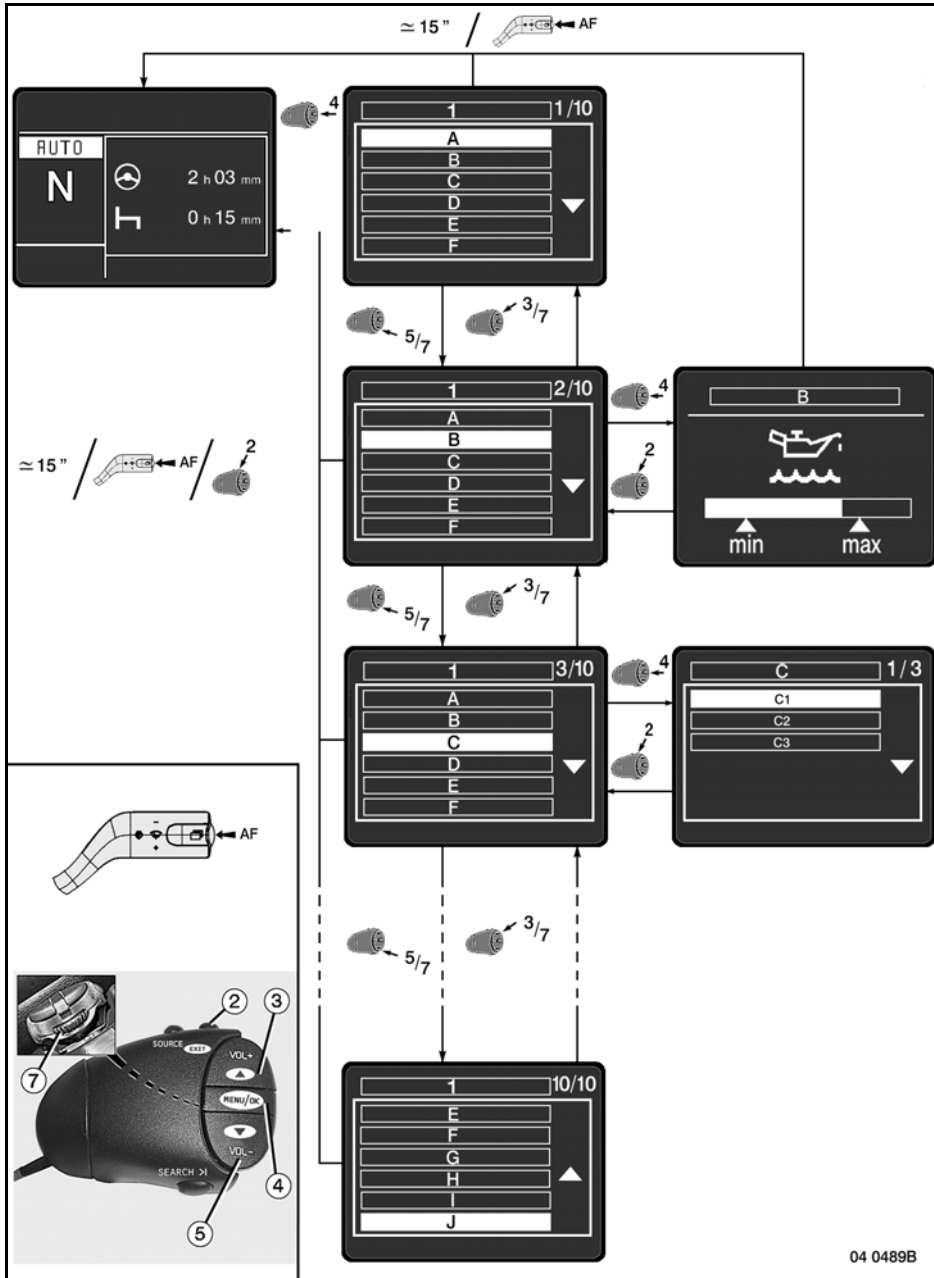

B2-35 Presentation

Menus and sub-menus

Use the remote control and control (AF) (see page B-2-30).

Press control (4) to gain access to the main menu (1). Controls (3) and (5) or thumbwheel (7) enable you to move around in the main menu in order to choose a menu. Press control (4) to open the menu selected or the relative sub-menu .

Control (2) serves to go back to the previous screen.



The use of sub-menus is identical as for using the main menu described above.

*Control (AF) serves to go back directly to the "SUPPLEMENTARY DRIVING INFORMATION" menu (**without confirmation**).*

*If after around 15 seconds, no action has been taken, the display goes back directly to the "SUPPLEMENTARY DRIVING INFORMATION" menu (**without confirmation**).*

(1) Main menu

- A: Reduced display
- B: Oil level
- C: Programming
 - c1: Heating programming
 - c2: Alarm clock programming
 - c3: Time zone changing
- D: Brightness
- E: Sound adjustments
 - e1: Sound level
 - e2: Choice of sounds
 - e3: Recommended gear
 - e4: Info
- F: Languages
 - f1: French
 - f2: English
 - f3: German
- G: Reminder of info
- H: Equipment message
- I: Expert
 - i1: Autotest
 - i2: Maintenance schedule
 - i3: Diagnostics
 - i4: Choice of units
 - i5: Day running lights
 - i6: Roller bench mode

To use the different menus, see the following pages.



When driving, only the "reduced display", "brightness" and "sound volume" menus are accessible.

B2-36 Presentation

A - Reduced display

This feature puts the multi-function information display into stand-by mode .

 Press control (4) to activate or disable lighting of the multi-function information display and press control (AF) to go directly to the "supplementary driving information" menu .

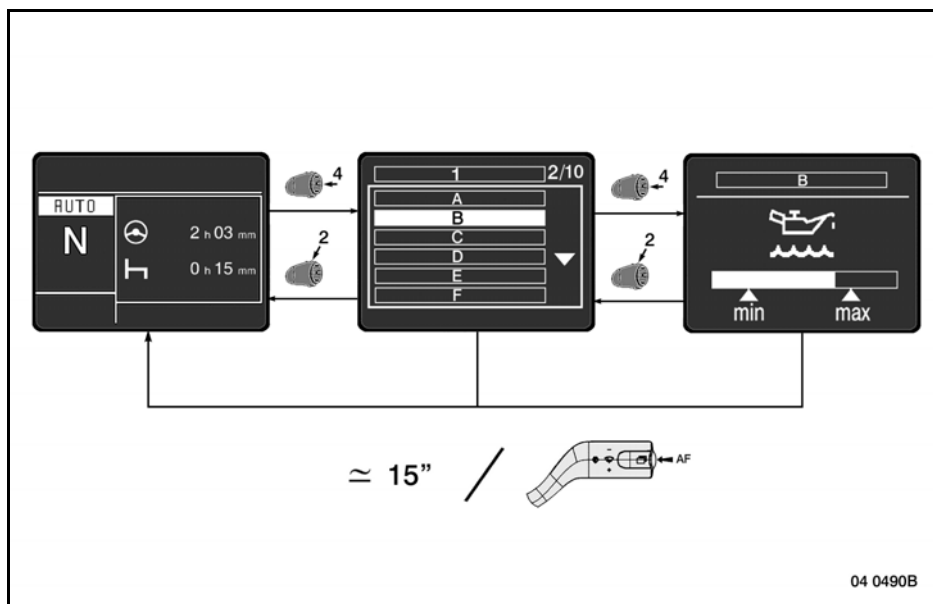

B - Oil level

The "oil level" menu can only be consulted when the engine has been shutdown.
For further details on how to interpret the value displayed, refer to page C-2-2.

 The oil level is displayed for 15 seconds, then the display returns to the "supplementary driving information" menu. Press control (2) to go back to the main menu (1) or press control (AF) to go back directly to the "supplementary driving information" menu.

B2-37 Presentation

C - Programming

This menu cascades down into 3 sub-menus.

c1 - Heating programming

This menu cascades down into 4 sub-menus.

c1-1 - Activation of programming

Choose the line (on / off) by pressing controls (3) - (5) - (7).

Confirm your choice by pressing control (4).

c1-2 - Choice of day

Choose the line by pressing controls (3) - (5) - (7).

Confirm your choice by pressing control (4).

Go back to the menu by pressing control (2).

Choose the line by pressing controls (3) - (5) - (7).

Confirm your choice by pressing control (4).

c1-3 - Choice of starting time

Adjust the hour by pressing controls (3) - (5) - (7).

Confirm by pressing control (4).

Adjust the minutes by pressing controls (3) - (5) - (7).

Confirm by pressing control (4).

Go back to the menu by pressing control (2).

c1-4 - Heating time

Choose the line by pressing controls (3) - (5) - (7).

Confirm your choice by pressing control (4).

Adjust the minutes by pressing controls (3) - (5) - (7).

Confirm by pressing control (4).

c2 - Alarm clock programming

c2-1 - Activation of programming

Choose the line (on / off) by pressing controls (3) - (5) - (7).

Confirm your choice by pressing control (4).

Go back to the menu by pressing control (2).

c2-2 - Disabling of programming

Choose the line (on / off) by pressing controls (3) - (5) - (7).

Confirm your choice by pressing control (4).

Go back to the menu by pressing control (2).

c2-3 - Choice of starting time

To adjust the time of day, see page B-2-38

When the alarm clock is programmed, the warning pictogram is shown on the information display.

To stop the alarm, press control (AF).

This action disables the alarm clock feature.

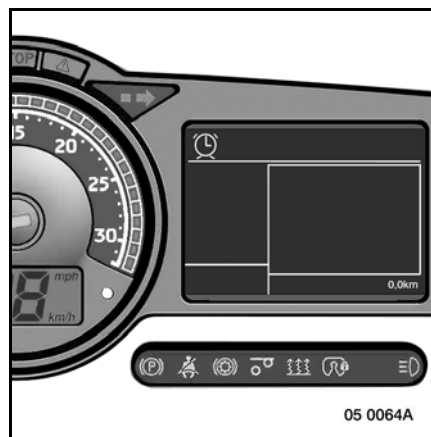

B2-38 Presentation

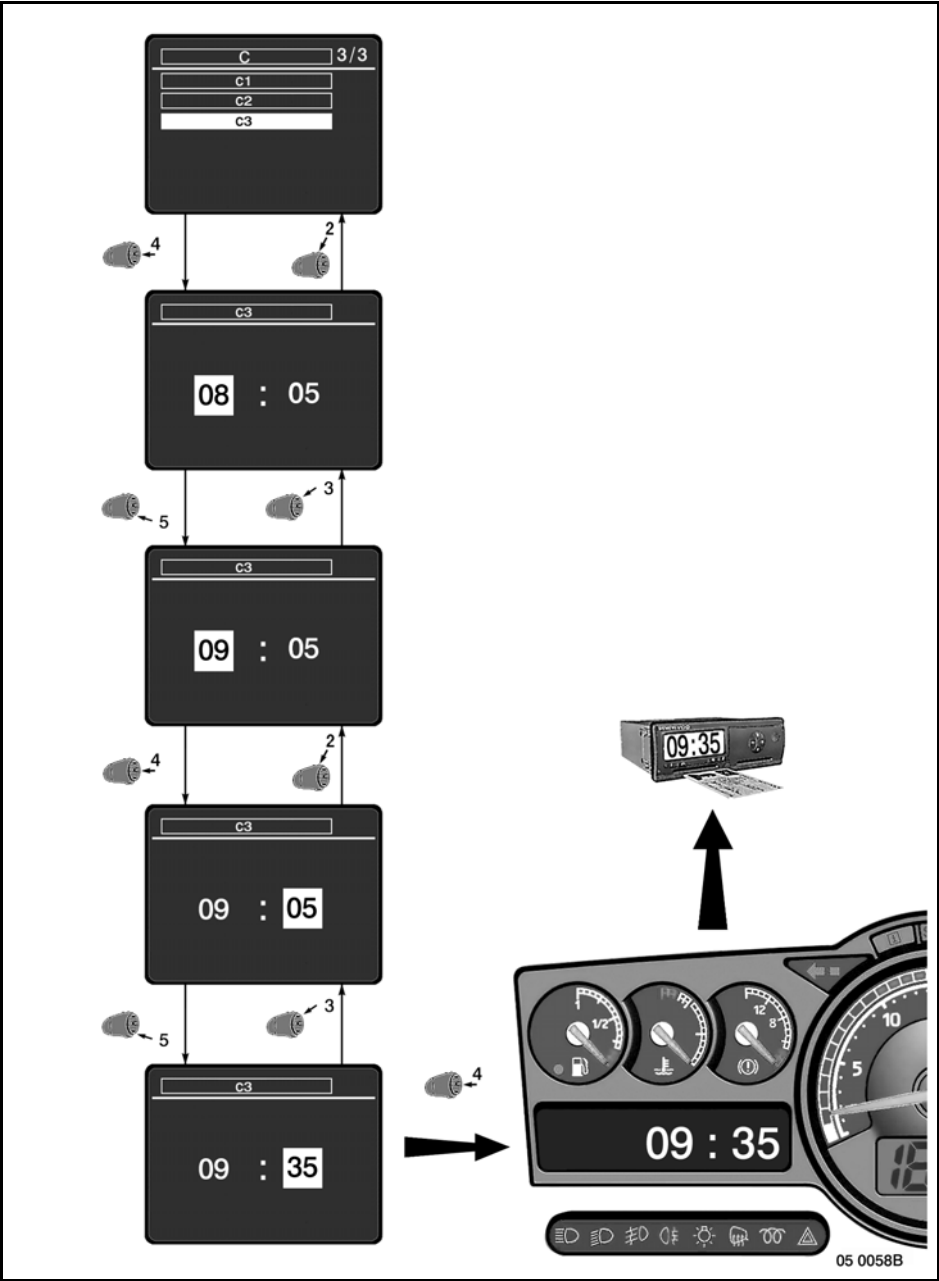

B2-39 Presentation

c3 - Adjustment to local time

This feature serves to adjust the time on the instrument panel and on the digital tachograph. Adjust the hour by pressing controls (3) - (5), confirm by pressing control (4).

Adjust the minutes (in 30 minute slices) by pressing controls (3) - (5), confirm by pressing control (4).



For vehicles equipped with a digital tachograph, it is possible to adjust the "UTC" (Coordinated Universal Time) by ± 1 minute per week (consult the tachograph manufacturer's instruction book).

Withdrawal of the tachograph chart causes automatic zeroing of the cumulated driving time and rest time.

When the driver's chart is inserted, the driving help information previously recorded on the chart is shown on the multi-function display after a few minutes.

D - Brightness

- Press control (3) = increase
- Press control (5) = reduce
- Press control (4) = confirm

B2-40 Presentation

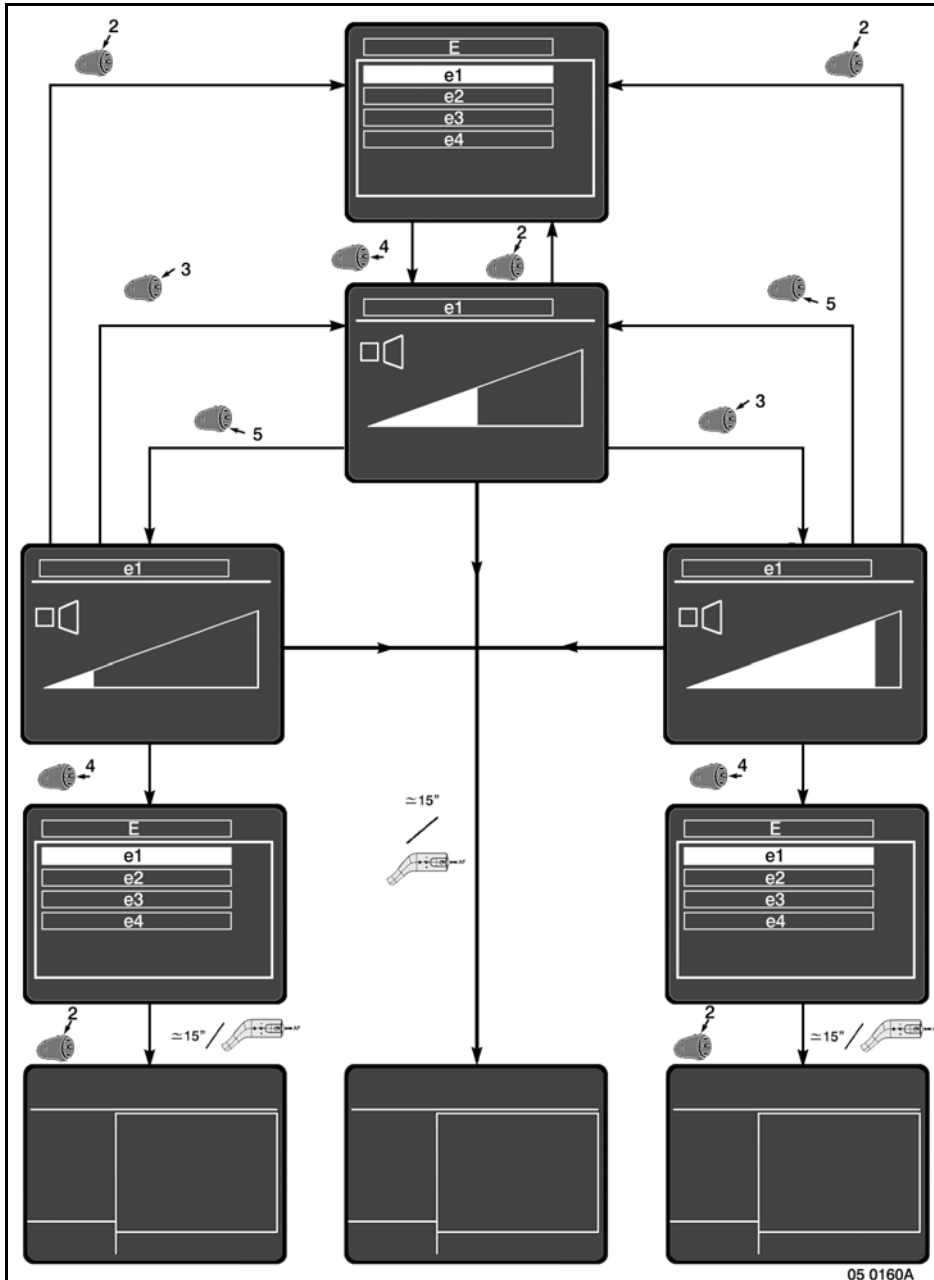

B2-41 Presentation

E - Sound level adjustment

e1 - Sound level

This function serves to modulate the sound volume.

Adjustment: see (D).

e2 - Choice of sounds

Choose the line (A / B) by pressing controls (3) - (5) - (7).

Confirm your choice by pressing control (4).

e3 - Recommended gear

Choose the line (A / B) by pressing controls (3) - (5) - (7).

Confirm your choice by pressing control (4).

e4 - Info

Choose the line (A / B) by pressing controls (3) - (5) - (7).

Confirm your choice by pressing control (4).

B2-42 Presentation

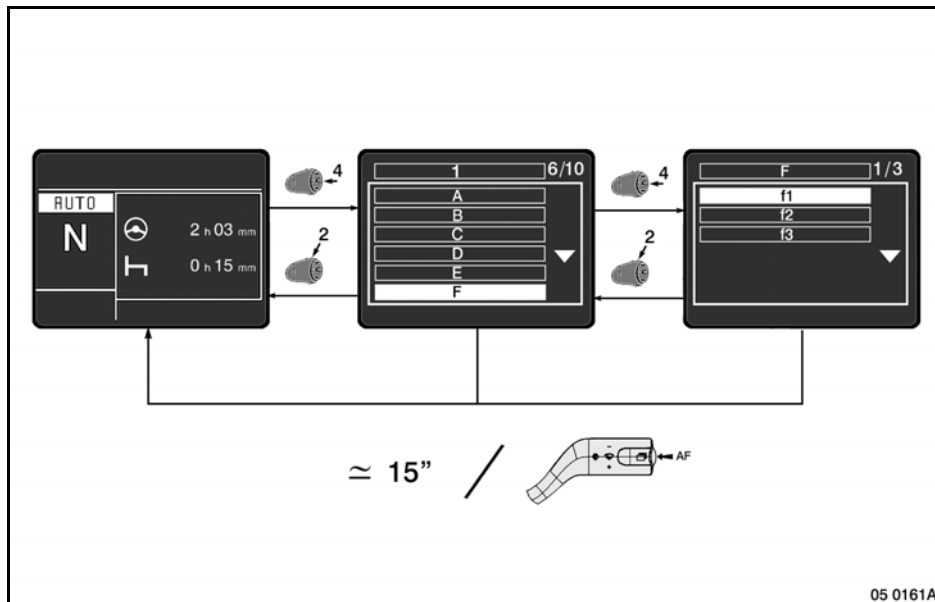

F - Languages

Select the language of your choice by pressing controls (3) and (5) then confirm by pressing control (4).

 Control (AF) serves to go back directly (**without confirmation**) to the "supplementary driving information" menu.
If after around 15 seconds, no action has been taken, the display goes back directly to the "supplementary driving information" menu (**without confirmation**).

Memorized language active .

f1 - first language " Français" "French".

f2 - second language "English" "English".

f3 - third language "Deutsch" "German".

Three languages are proposed by default. This choice of languages can be modified by a RENAULT TRUCKS service point or dealer.

B2-43 Presentation

G - Reminder of info

This function serves to view active functions and present faults at the moment of consultation of this menu by displaying the corresponding pictograms.

H - Equipment message

This feature serves to view initialized bodybuilder functions.

B2-44 Presentation

I - Expert

This menu cascades down into 6 sub-menus.

This feature serves to check out the information display.

i1 - Autotest

i2 - Maintenance schedule

- Drive belt
- Air filter
- Coolant
- Air dryer
- Gearbox oil
- Engine oil
- Brake linings
- Last brake change
- Clutch
- Alternator brushes
- Starter brushes
- Drive axle oil
- Regulatory inspection
- Tachograph inspection



Keep control (4) pulled out for more than 5 seconds to update mileage or date information.

Choose the feature by pressing controls (3) - (5) - (7).

Confirm by pressing control (4).

i3 - Diagnostics

- Transponder
- Present faults
- Flashing codes
- Part numbers
- Memorized faults

i4 - Choice of units

Choose the unit (km/h / mph) by pressing controls (3) - (5) - (7).

Confirm by pressing control (4).

i5 - Day running lights

Choose the feature (on / off) by pressing controls (3) - (5) - (7).

Confirm by pressing control (4).

B2-45 Presentation

i6 - Roller bench mode

Choose the feature (on / off) by pressing controls (3) - (5) - (7).
Confirm by pressing control (4).



Some of these sub-menus cascade down in turn into sub-menus that usually represent each of the electronic boxes or ECUs fitted to your vehicle.

This feature serves to view faults affecting the vehicle.

If several faults originate from the same electronic box or ECU, you can consult them in succession by pressing controls (3) - (5) - (7).

B2-46 Presentation

Electrically operated rearview mirrors

With the master switch engaged, move control (1) to position:

- **A** to adjust the LH rearview mirror.
- **C** to adjust the RH rearview mirror.
- **B** to render the control inactive.

Adjustment

Select the rearview mirror to be adjusted, then press control (1). The control is of the omnidirectional type.

Defrosting

To defrost, actuate the control (2).

The warning light (Y) comes on during the defrosting operation.

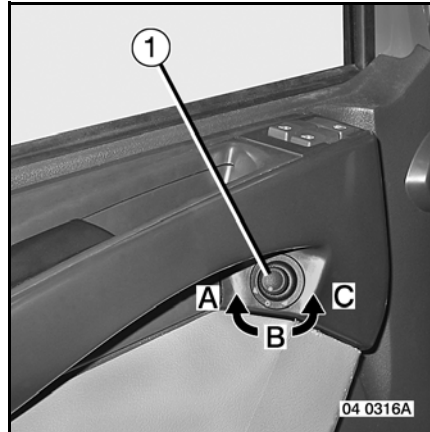

Depending on your vehicle's equipment

Heated windscreen

Defrosting:

The windscreen is defrosted in conjunction with the electrically controlled rearview mirrors.

When switch (2) is actuated, the windscreen defrosting operation lasts for 12 minutes.

The rearview mirrors are defrosted full-time.

The built-in warning light (Y) comes on during the defrosting operation.



B2-47 Presentation

Combined lights and horn switch

Direction indicator

Move the control stalk parallel to the steering wheel.

Position (1): RH flasher.

Position (2): LH flasher.

When the stalk is released, it automatically returns to its initial position.



The warning lights associated with the direction indicator inform you on the state of the system (see page B-2-12).

Horn

Push down on the end of the control stalk to sound.

Headlamps flasher warning unit

Pull the control stalk towards you.

Warning light (AE) comes on.

Lights

Side/parking lights

Turn the control stalk to position (3).

Dipped beam headlights

Turn the control stalk to position (4).

Warning light (AC) comes on.

Main beam headlights

With the control stalk in position (4), pull the control stalk towards you to position (5).

Warning light (AE) comes on.

To dip the headlights again, pull the control stalk towards you to position (5).

Warning light (AC) comes on.

The instrument panel lighting comes on in all "Lights" positions.

Extinction

The control stalk must be in position (6).

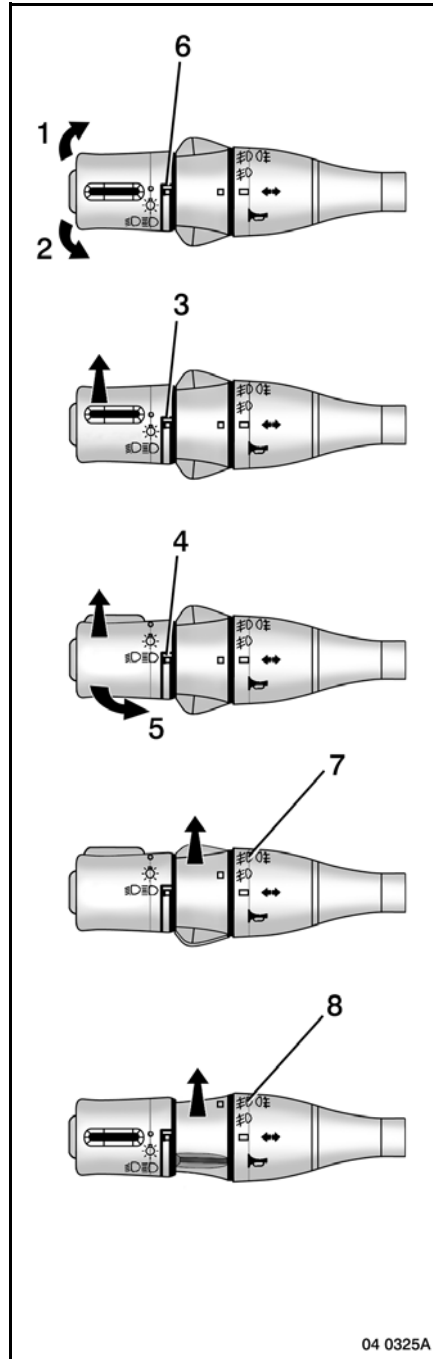

B2-48 Presentation

Fog driving lights

With the side/parking lights or dipped beam headlights on, turn the ring to position (7). Warning light (AB) comes on.

Fog driving lights and rear fog lights

With the side/parking lights or dipped beam headlights on, turn the ring to position (8). Warning lights (AA - AB) come on.



When the fog driving lights are on, it is not possible to use the main beam headlights.

Depending on your vehicle's equipment

Control without fog driving lights

Rear fog lights

With the dipped beam headlights on, turn the ring to position (9). Warning light (AA) comes on.

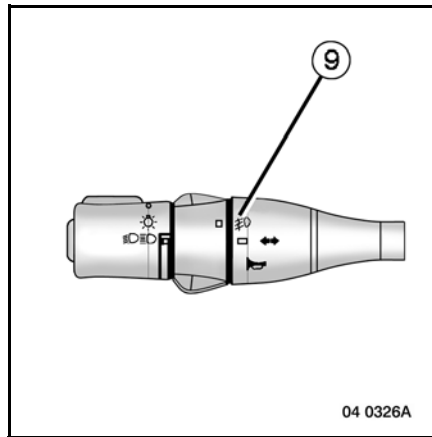

If the dipped beam headlights warning light does not come on (AC), check the operation of the dipped beam headlights; if necessary, replace the defective bulb (see page E3-1).

If the trouble is not due to the bulbs, Make your way to the nearest RENAULT TRUCKS service point or dealer.

B2-49 Presentation

Headlights adjustment

Depending on your vehicle's equipment

Vehicle unladen: thumbwheel (1) is in position "0".

Vehicle laden: turn thumbwheel (1) to correct the beam height.

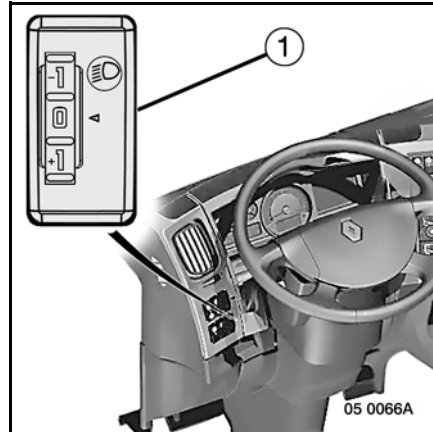

Windscreen wiper, windscreen wash and headlamps wash control

Move the control stalk parallel to the steering wheel.

Position (1): Stop.

Position (2): Intermittent wipe.

Position (3): Slow wipe.

Position (4): Fast wipe.

Flick wipe:

Flick the control stalk in the direction of position (5) and let it return on its own. The windscreen wiper will make 2 to and fro wipes.

Hold the control stalk in position to operate at the same time:

- screen wipe and screen wash,
- headlamp wash (if fitted) provided the lights are on.

When you release the stalk, headlamp washing and screen washing are interrupted. The screen wiper continues for a few wipes before stopping.

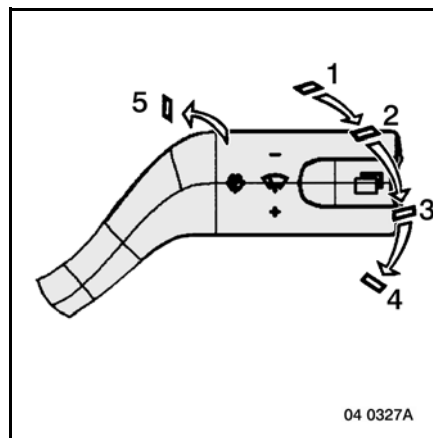

B2-50 Presentation

Adjusting the steering wheel

Press control (1).

This control features a time-delay.

Pull, lift, lower or push the steering wheel to the required position.

Lift up control (1) or wait until the end of the time-delay.



Control (1) will enter into operation when the circuit air pressure is sufficient.

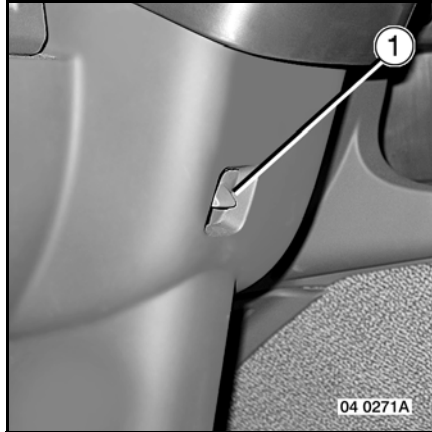

B2-51 Presentation

Parking brake

This valve acts simultaneously on the rear axle of the tractor and on the semi-trailer.

Release

Lift the locking sleeve and move the lever from position (2) to position (1). Warning light (S) goes out.

Application

Move the lever from position (1) to position (2) (negotiate the hard spot). Make sure the lever is correctly locked in position (2). Warning light (S) comes on.

See page(s) C4-50.

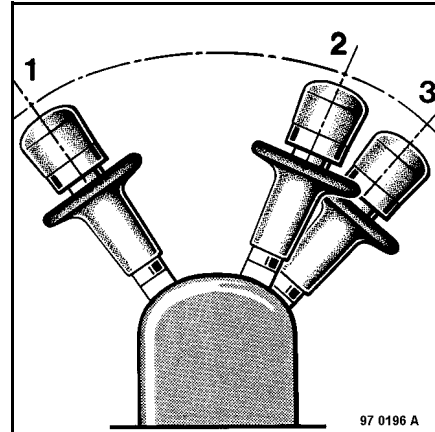

Depending on your vehicle's equipment

Vehicle with trailer

Before leaving the vehicle, move the lever to the "Test" position to ensure efficiency of the parking brake.

Test

Press the lever and move it from position (2) to position (3). This position releases the trailer brake and holds the road combination on the tractor brake. This position serves to ensure that the tractor can alone hold the entire immobilized vehicle.

As soon as the lever is released, it returns automatically to position (2), i.e. to the parking position.

B2-52 Presentation

Electric window raiser controls

- (1) - Driver's left side window raiser control
- (2) - Driver's right side window raiser control
- (3) - Passenger's right side window raiser control

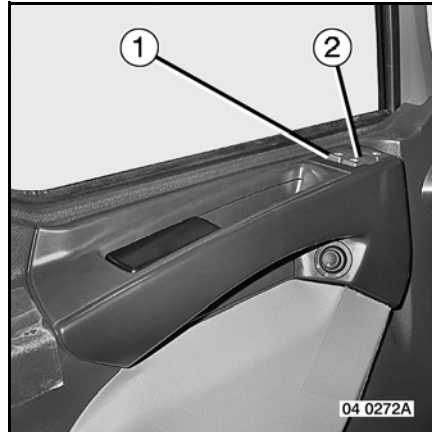

Use of the controls:

Lowering: Press the front of the control..

Raising: Press the rear of the control..

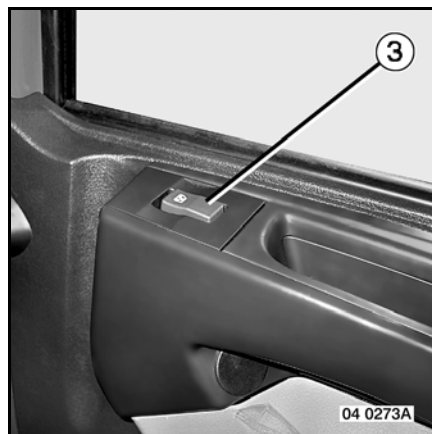

B2-53 Presentation

Roof air vent

Depending on your vehicle's equipment

Opening

Push air vent (1) as far as the required degree of opening.

Closing

Return the air vent to its initial position.

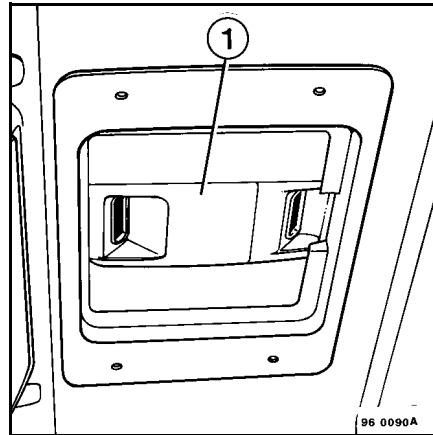

Electrically operated sun-roof

The sun-roof is operated by means of a 2-position control switch (F3).

Opening

Press end (2) of the control until the sun-roof opens as far as you wish.

Closing

Press end (1) of the control until the sun-roof is fully closed.

Before you leave the vehicle, as precaution, make sure the sun-roof is properly closed.

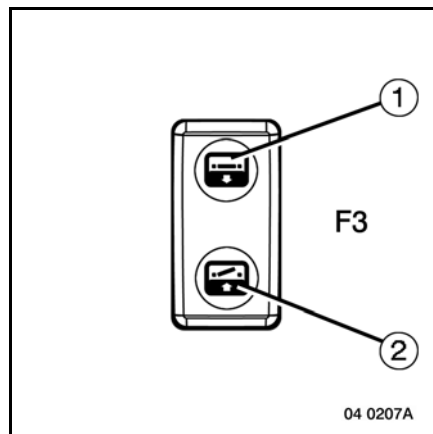

In the event of incident, it is possible to operate the sun-roof by hand.

Remove trim (1 - 2) to gain access to the emergency control.

Insert a 5 mm Allen key into hole (3). Drive in the key to release the motor clutch and turn it to operate the sun-roof.

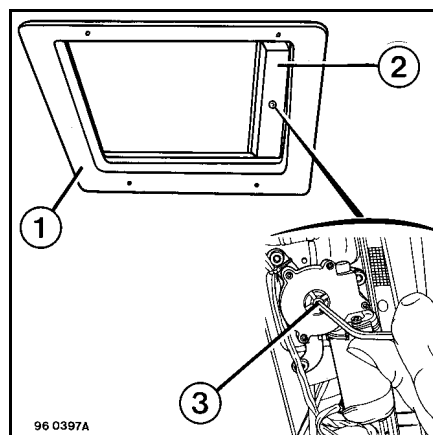

B2-54 Presentation

Heating - Ventilation

Depending on your vehicle's equipment

Version without air conditioning:

- 1- Cab air distribution control
(see detail page B-2-55).
- 2- Temperature variator
(see detail page B-2-57).
- 3- Ventilation control
(see detail page B-2-56).

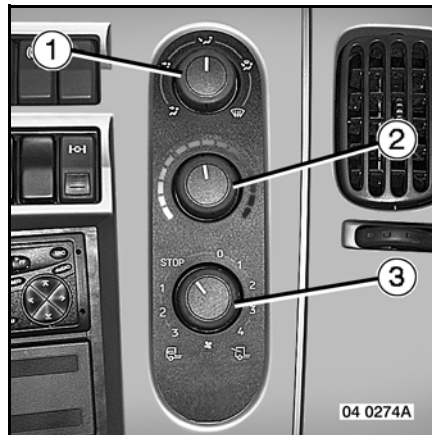

Version with non-regulated air conditioning:

- 1- Cab air distribution control knob
(see detail, page B-2-55).
- 2- Temperature variator knob
(see detail, page B-2-57).
- 3- Ventilation control knob
(see detail, page B-2-56).
- 4- Air conditioner control
(see detail, page B-2-57).

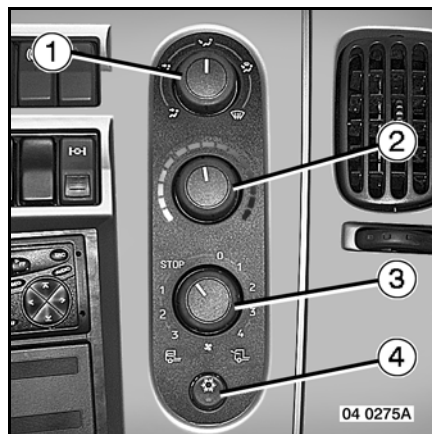



To limit risks of leakage subsequent to prolonged lay-up, it is recommended to run the air conditioning system for a few minutes at least once a week.

B2-55 Presentation

Cab air distribution control knob

The control distributes the air between the various outlet ports according to the position chosen.

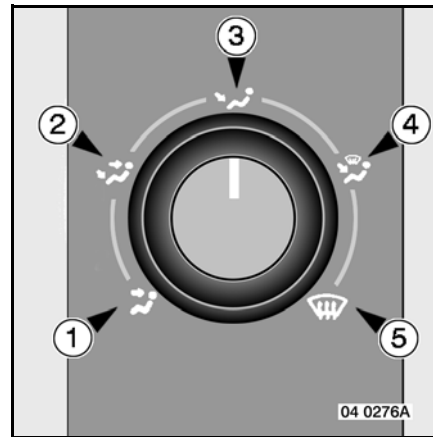
Combined with the temperature variator and the ventilation control, it assures optimized temperature according to the positioning of the outlets.



Position 1

Air directed upwards (to the dashboard air vents) and gentle flow downwards (to the footwell).

Position 2

Air directed upwards (to the dashboard air vents) and downwards (to the footwell).

Position 3

Air directed downwards (to the footwell) and gentle flow upwards (to the windscreen).

Position 4

Air directed downwards (to the footwell) and gentle flow upwards (to the windscreen and side windows).

Position 5

Air directed upwards only (to the windscreen and side windows).



When the side and central air vents are open, the air flow is distributed between the different ports selected for each control position.

B2-56 Presentation

Ventilation control knob

This control knob incorporates two features:

External air ventilation feature

Turn the knob clockwise.

- Position STOP: stop (air intake closed).
- Position 0: stop (air intake slightly open).
- Position 1: fan control (1st speed).
- Position 2: fan control (2nd speed).
- Position 3: fan control (3rd speed).
- Position 4: fan control (4th speed).



Internal air ventilation feature (recycling)

Turn the knob anti-clockwise.

- Position STOP: stop (air intake closed).
- Position 1: fan control (1st speed).
- Position 2: fan control (2nd speed).
- Position 3: fan control (3rd speed).



Recycling makes it possible to:

- avoid breathing in stale air from the exterior (road tunnels, polluted areas...).
- obtain maximum cooling or maximum heating power from the air conditioner.

Only use the recycling feature in short spells.

B2-57 Presentation

Air conditioner control button (6)

With the engine running, move the ventilation control knob to at least position 1 and press the air conditioner control button to operate the air conditioning.

A built-in warning light comes on when the air conditioning feature is activated.

Set the temperature variator to the desired temperature.



Temperature variator knob

Move the temperature variator knob to the desired temperature:

- blue zone: cold.
- blue/red zone: temperate.
- red zone: hot.

Once you have made the adjustment, wait for a few moments to appraise the result before changing it slightly, if necessary.

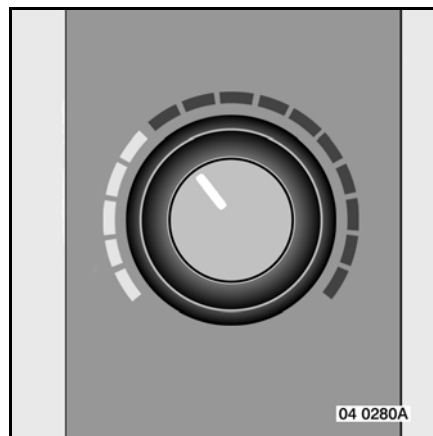

B2-58 Presentation

Quick defrosting ("Warm hold" feature)

This device speeds up the defrosting function.

With the vehicle stationary, for an ambient temperature below 5°C and a coolant temperature below 70°C, after a time-delay that is variable according to ambient temperature and engine temperature, a device holds the engine at the idling speed of that moment and actuates the exhaust brake so as to quickly raise temperature of the engine cooling system.

This function is disabled when the cooling system temperature reaches 70°C, then reactivated as soon as the circuit temperature drops below 50°C.

Conditions permitting the "WARM HOLD" function

- ambient temperature below 5°C,
- coolant temperature below 70°C,
- road speed below 3 km/h,
- no PTOs active.

Conditions preventing the "Warm hold" function

- ambient temperature above 5°C,
- coolant temperature above 70°C,
- road speed above 3 km/h,
- action on the accelerator pedal,
- activation of a PTO,
- vehicle with OPTIDRIVER 2 gearbox, changeover from (N) (neutral) to (D).



If the parking brake is not applied, the "warm hold" function can only be activated after a time-delay of 150 seconds.

B2-59 Presentation

Use in cold weather:

Defrosting / demisting

- Close the side and central air vents.
- Move the fan control to position "0" (external air side).
- Move the air distribution control knob to the "defrosting/demisting".
- Move the temperature variator knob into the "hot" zone.

As soon as the temperature rises:

- Move the ventilation control knob to position 1.

With air conditioning:

- Press the air conditioner control button.

With or without air conditioning:

- Increase the air flow as the engine temperature rises.

When the "defrosting/demisting" action is finished, move the temperature variator into the desired zone. The reaction time varies according to the position chosen. Maintain a minimum air flow for better efficiency.

Use in hot weather:

If the temperature inside the cab is higher than the outside temperature:

- Aerate the cab by driving for a few minutes with the windows down.
- Move the temperature variator knob to "max. cold" and the ventilation control knob to position 4 to obtain maximum air flow.

With air conditioning:

- Press the air conditioner control button.

As soon as the desired level of comfort is reached:

With or without air conditioning:

- Return the temperature variator knob to a more moderate position.
- Choose the air distribution control knob position.
- Reduce the ventilation. Maintain a minimum air flow for better efficiency (position 1 minimum).

If you wish to increase the heating or cooling power, use the cab air recycling feature with the air conditioner engaged. Only use the recycling feature in short spells.

B2-60 Presentation

Air vents

To open the air flow:

turn thumbwheel (1) anticlockwise.

To close the air flow:

turn thumbwheel (1) clockwise.

To swivel horizontally: tilt the air vent.

To swivel vertically: use control (2).

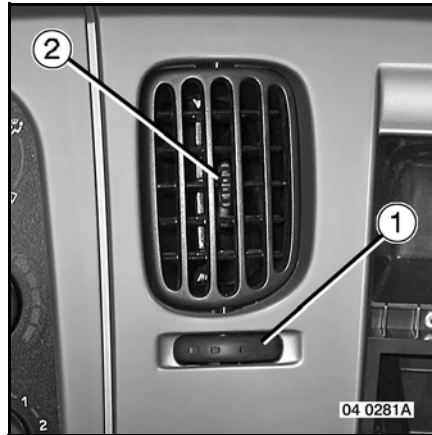

 THE EVOLUTION OF CLIMATE CONTROL AND SOUNDPROOFING HAVE LED TO CABS BECOMING MORE AND MORE HERMETICALLY SEALED. IT IS THEREFORE NECESSARY, WHEN YOU HAVE TO STAY INSIDE THE CAB FOR A LONG PERIOD, TO PROVIDE ADEQUATE VENTILATION (WINDOWS PARTLY OPEN, ROOF AIR VENT) TO AVOID CONFINEMENT OF THE AIR.

B2-61 Presentation

Independent heating

Depending on your vehicle's equipment



**Shut off the heater unit near filling stations. Whenever electric welding is carried out on the vehicle it is absolutely essential to disconnect the batteries to avoid destruction of the electronic monitoring system.
Stop the heater before disengaging the master switch.**



THE EVOLUTION OF CLIMATE CONTROL AND SOUNDPROOFING HAVE LED TO CABS BECOMING MORE AND MORE HERMETICALLY SEALED. IT IS THEREFORE NECESSARY, WHEN YOU HAVE TO STAY INSIDE THE CAB FOR A LONG PERIOD, TO PROVIDE ADEQUATE VENTILATION (WINDOWS PARTLY OPEN, ROOF AIR VENT) TO AVOID CONFINEMENT OF THE AIR.

Independent heater fuel supply

The independent heater operates perfectly with commercial diesel fuel. If the heater is supplied from a separate tank, it must contain the same diesel fuel as the vehicle fuel tank. When changing over from summer diesel fuel to winter diesel fuel, run the independent heater to purge the fuel pipes.



WHEN USING THE INDEPENDENT HEATER, MAKE SURE THE DISCHARGE APERTURE (1) IS NOT OBSTRUCTED.

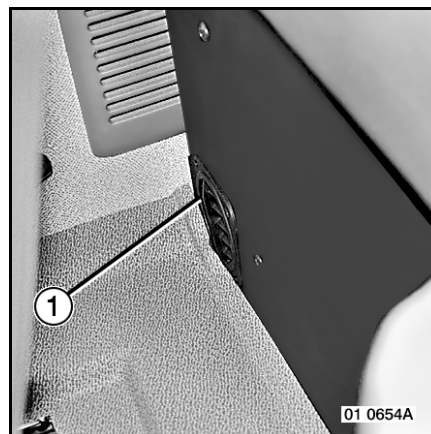

B2-62 Presentation

Non "ADR" independent heater

Prior to starting, make sure the suction and discharge apertures are not obstructed. There should be no objects encumbering the area reserved for the heater unit.

Temperature regulation

Set the required temperature on thermostat (F1).

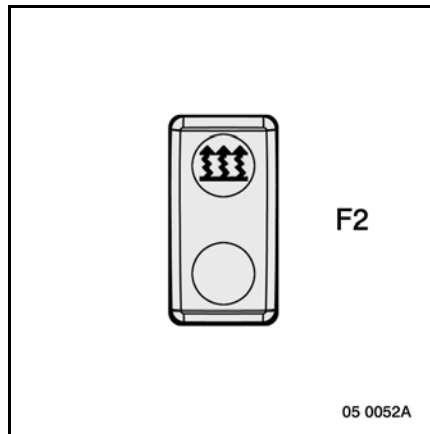
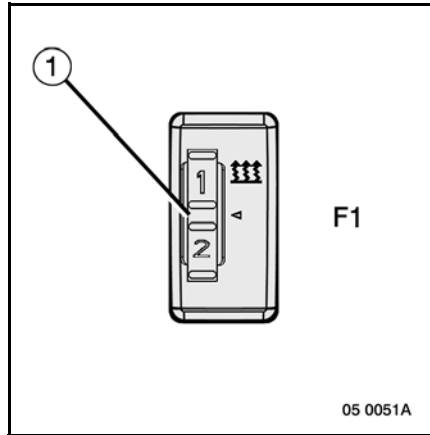

Start-up without programming

Press button (F2).

Warning pictogram (O) appears.

The flame glow plug is supplied with voltage and the blower runs at low speed. After about 30 seconds, combustion begins. Check that the heater is operating correctly. The blower speed varies according to temperature.

Heater operating time

The timer limits the heater operating time to 120 minutes.

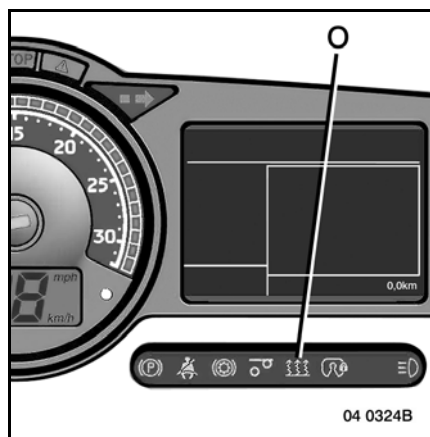

B2-63 Presentation

Stopping

Press button (F2). Warning pictogram (O) disappears. The blower continues turning to cool the heater (retarded shutdown) then stops automatically.

Heating programming

To programme the heating, see page B-2-37
When programming is finished, warning pictogram (1) appears on the information display.

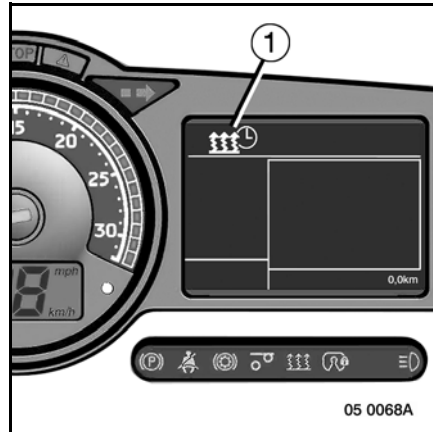

Air/water heater specific details

With switch (F6) in the "off" position: heating of the engine and cab water circuit.

With switch (F6) in the "on" position (switch warning light on): priority to heating of the cab water circuit. The engine circuit is heated only a little.

Use with switch

Move the ventilation and temperature adjustment controls to the required positions.
See pages B2-54.

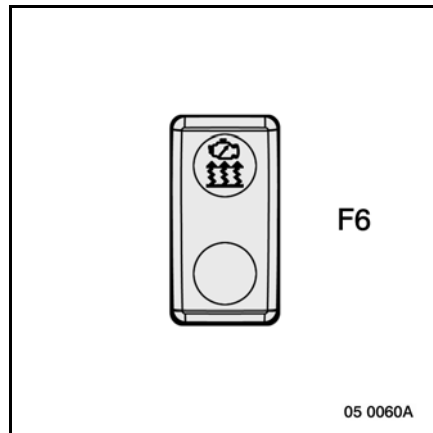

Use without switch



For the air/water heater, move the ventilation control to the (stop) or (0) position (see page B-2-56).

B2-64 Presentation

Troubleshooting

Heater will not start

Heater will not start: check fuse(s) (F1 - F31 - F76 - F108) and press button (F2) again.

If the heater does not start after the start-up cycle, call in a RENAULT TRUCKS service point or dealer.

Heater stops when in operation

Heater overheating

Make sure the suction and discharge apertures are not obstructed.

After a few minutes, restart the heater (warning light (O) visible).

If it stops again, call in a RENAULT TRUCKS service point or dealer.

Flame goes out: find the cause.

- Fuel supply defect.
- Electrical power supply failure.
- Appliance or regulation control unit defect.

To restart, press button (F2) to stop and repeat the procedure (no more than 3 times).

If the heater stops again, call in a RENAULT TRUCKS service point or dealer.



It is forbidden to use the heater in closed premises or in places where inflammable or explosive vapours or accumulations of dust might be produced.

Avoid exposing gas cartridges and spray canisters to the hot air flow.

If electric welding work is carried out on the vehicle, it is essential to disconnect the batteries to prevent causing irreparable damage to the electronic control system.

Stop the heater before disengaging the master switch.

B2-65 Presentation

Air/water heater

Appliance overheating

Let the heater cool down, then re-engage circuit-breaker (13) by pressing the rubber plunger.

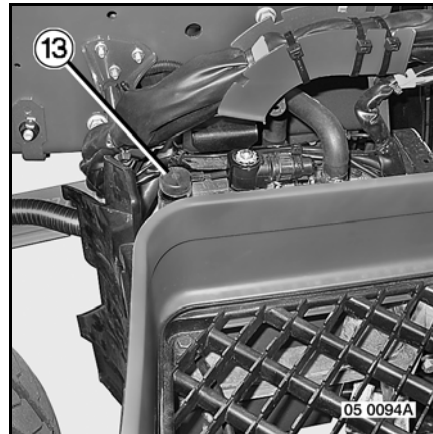

Diagnostic socket (3)

The diagnostic socket serves for checking out the independent heating system using the RENAULT TRUCKS test tool.

To gain access to diagnostic socket (3) (2) through 1/4 of a turn (3), to open cover (1).

If warning pictogram (O) flashes, contact a RENAULT TRUCKS service point or dealer.

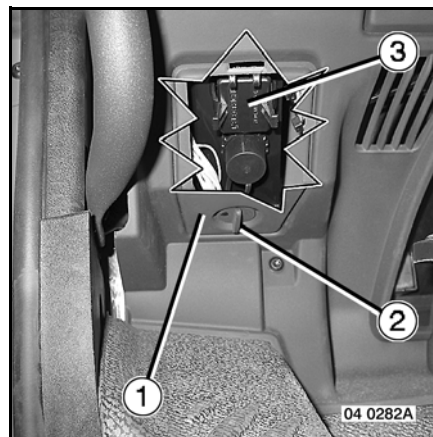

B2-66 Presentation

WEBASTO independent heater type AT 2000 ST "ADR"



This heater cannot be programmed.

Prior to starting, make sure the suction and discharge apertures are not obstructed. There should be no objects encumbering the area reserved for the heater unit.

Starting up

Press button (F2).

Warning pictogram (O) appears.

The flame glow plug is supplied with voltage and the blower runs at low speed. After about 30 seconds, combustion begins. Check that the heater is operating correctly. The blower speed varies according to temperature.

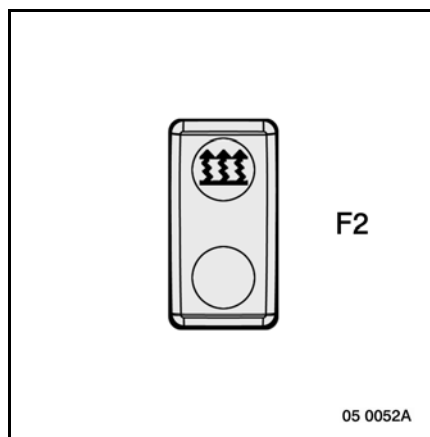

Stopping

Press button (F2). Warning pictogram (O) disappears. The blower continues turning to cool the heater (retarded shutdown) then stops automatically.

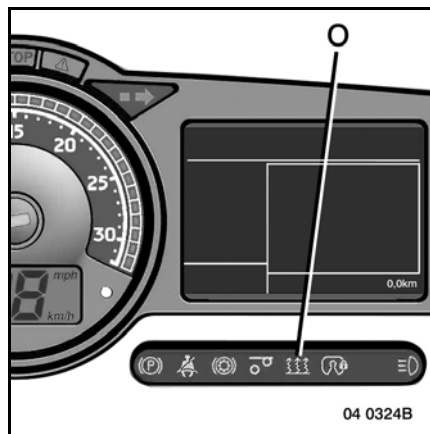

B2-67 Presentation

Temperature regulation

Set the required temperature on thermostat (11).

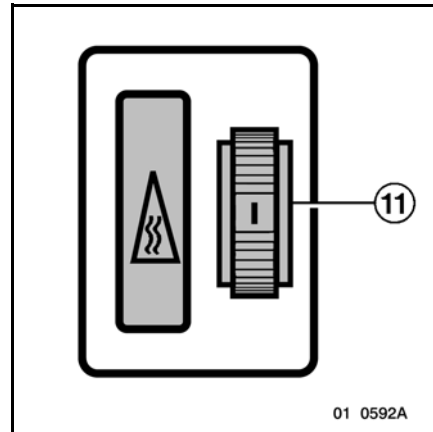

Shut off the heater near service stations and when you are filling your vehicle with fuel.

Switch off the heater before entering any high risk zones.



The heating may change over to safety mode in the following cases:

- when the ignition is switched off;
- when a PTO is set into service;
- when an offloading pump is set into service (if the bodybuilder connection has been made), even though it has not been turned off with the switch .

In such case, when the ignition is switched on, the light comes on but the heating does not start up:

- Press the switch a second time: the heater runs through its ventilation cycle, then stops:
- Press the switch twice again: the heater starts up again.

B2-68 Presentation

Diagnostic socket (1)

The diagnostic socket serves for checking out the independent heating system using the RENAULT TRUCKS test tool.

To gain access to diagnostic socket (3) (2) through 1/4 of a turn (3), to open cover (1).

If warning pictogram (O) flashes, contact a RENAULT TRUCKS service point or dealer.

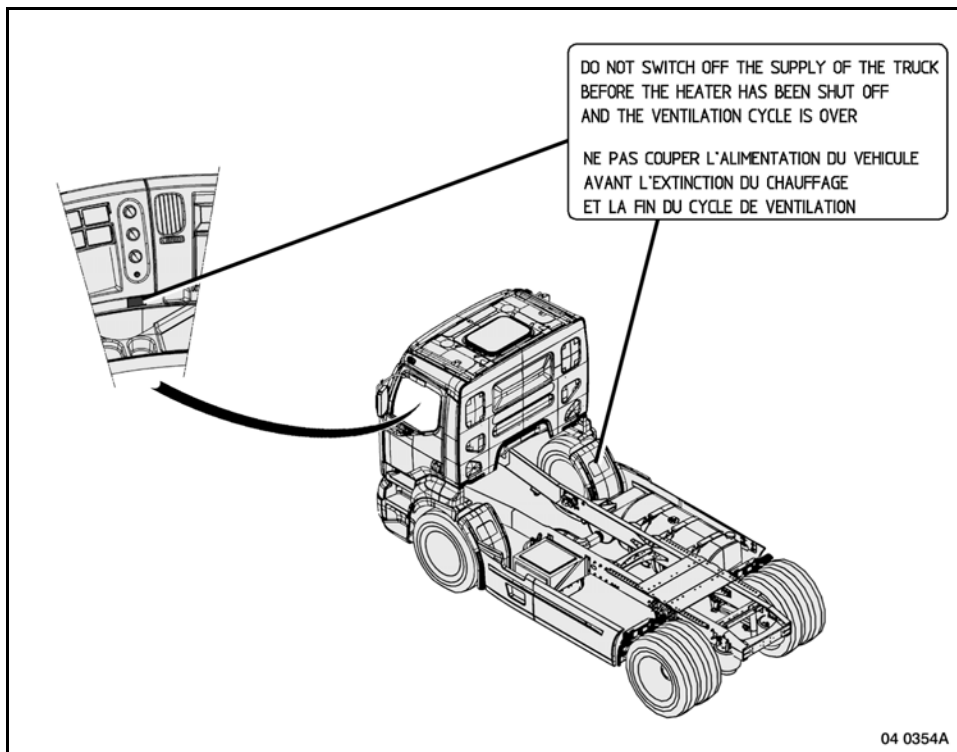
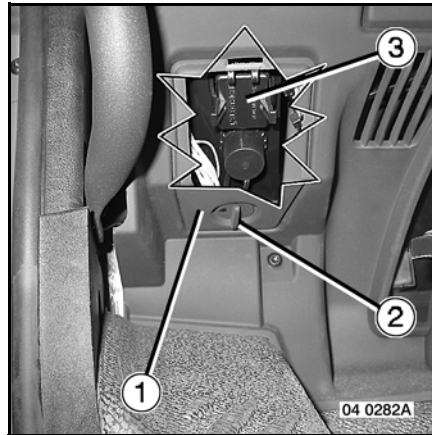

B2-69 Presentation

Bunks and storage compartments

Depending on your vehicle's equipment

Top bunk

To position the bunk, move the seats forwards.
Before taking the road, raise the bunk.



**WHEN THE TOP BUNK IS IN USE,
UNWIND RETAINING NET (1) AND
FASTEN IT WITH HOOKS (2).**

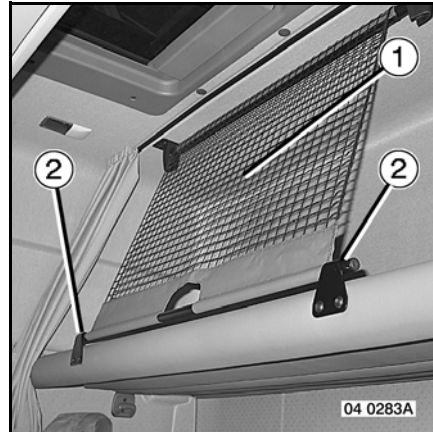

Bottom bunk

- 1- Storage compartments.
- 2- Storage space or refrigerator.

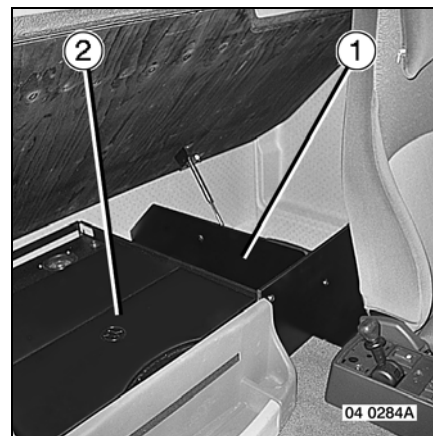
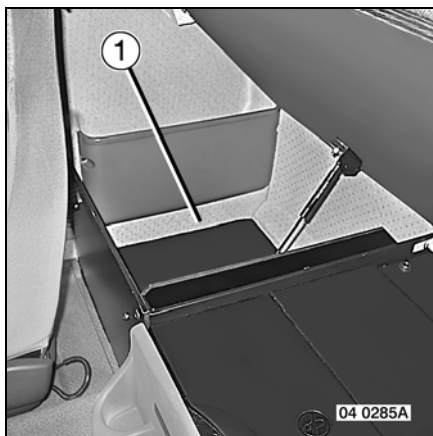

*Storage compartment (1) located on the independent heater supports a load of less than 10 kg.
Before tilting the cab, switch off the refrigerator, empty it and the storage compartments.*

B2-70 Presentation

Bench seat convertible into a bunk

To convert the rear bench seat squab into a top bunk, lift up the squab to unlock, then pull to lock it in the "up" position.

To convert the bench seat cushion into a bottom bunk, pull on strap (1) to lift up the cushion and raise the lower portion (2) into the "bunk" position.

Proceed in the reverse sequence to go back to the "bench seat" configuration.

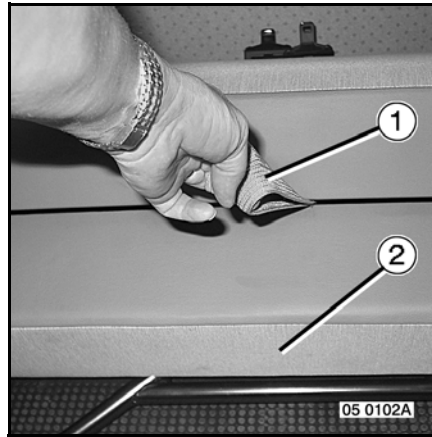

Storage compartment (2)

Opening

Push handle (3) downwards and pull compartment (2) forwards.

Closing

Push handle (3) downwards and push compartment (2) backwards until the lock engages automatically.

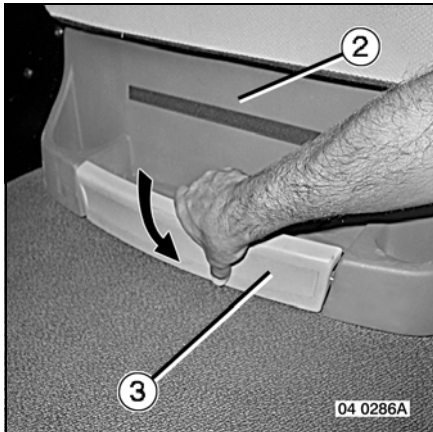

B2-71 Presentation

Depending on your vehicle's equipment

Refrigerator

Operation

A thermostat (4) regulates the operating temperature.

To stop the refrigerator, move the thermostat to the "0" position.



In the event of malfunction, call upon a RENAULT TRUCKS service point or dealer.

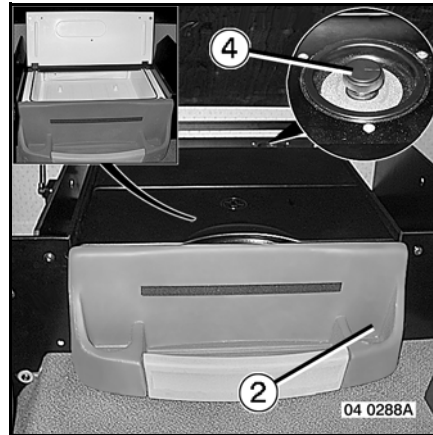

Top ledge storage space

- 1- Storage compartments.
- 2- Shelf.

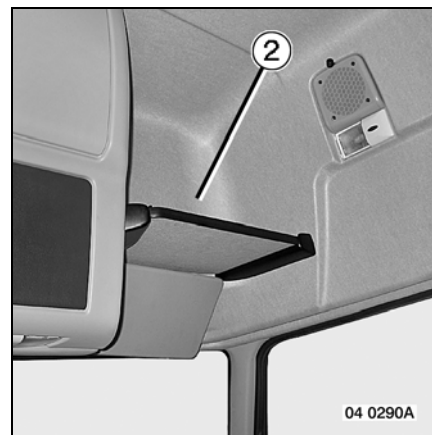
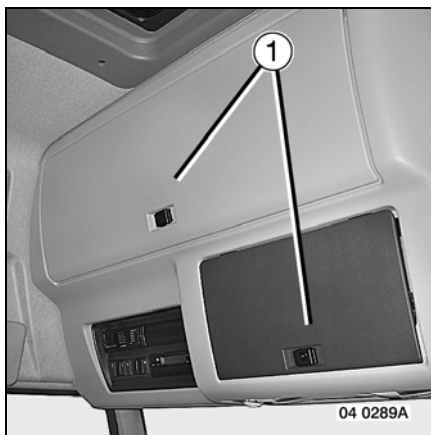

B2-72 Presentation

Dashboard storage spaces

- 1- Drawer.
- 2- Glove box.

Glove box (2).

Opening

Press handle (3).

Closing

Push the door until it snaps shut automatically.

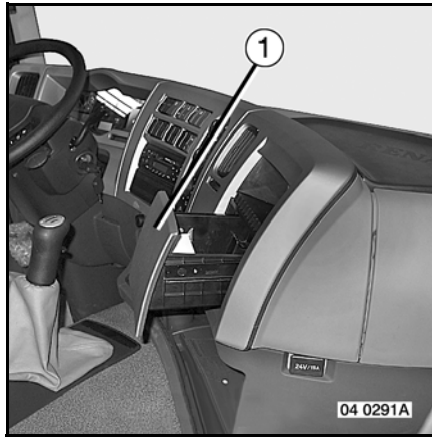

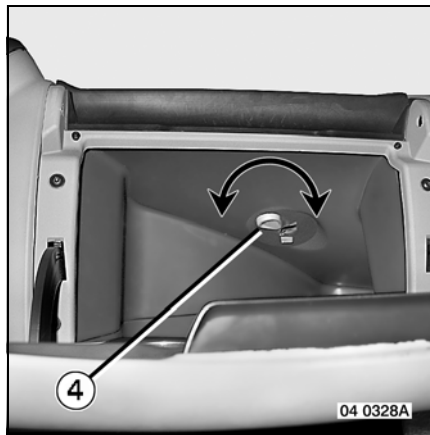
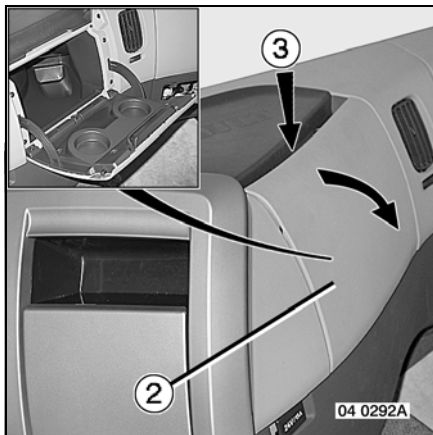

If your vehicle is equipped with air conditioning, pivot blanking plug (4) to chill glove box (2)

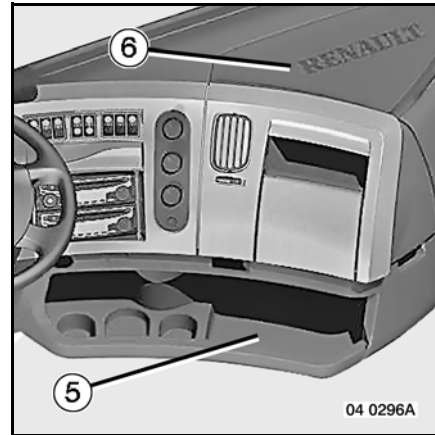

B2-73 Presentation

Oddments tray (5).
Ledge (6) features a non-slip surface .



 **USE LEDGE (6) ONLY WHEN THE VEHICLE IS STATIONARY. IT SHOULD BE FREE FROM ALL ARTICLES WHEN THE VEHICLE IS MOVING OR WHEN THE CAB IS BEING TILTED.**

B2-74 Presentation

Cab overhead lights

Switch (3) lights the swivelling map reader (1). Each overhead light (2) features one lighting switch (4) with 2 positions.

The overhead lights come on, depending on the equipment, when the doors are opened or automatically (see page B-1-7).

Switches (4) serve to switch on the overhead lights when you so wish.

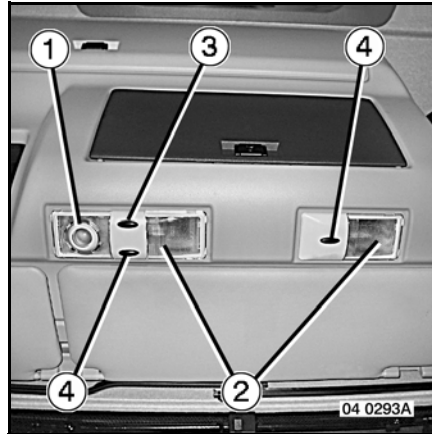

Onboard radio

Depending on your vehicle's equipment

Carefully read the notice supplied in the onboard kit.

Radio remote control

- 1- Select stations (radio).
- 2- Go back to menu or previous setting (display).
- 3- Increase radio sound volume / move around in menu.
- 4- Call up main menu / access menu or sub-menu selected / confirm settings (display).
- 5- Reduce radio sound volume / move around in menu.
- 6- Activate automatic station search (radio).
- 7- Scroll through memorized radio stations / scroll through menus.



 To mute the sound, press controls (3 - 5) simultaneously.

B2-75 Presentation



For any work on the onboard radio, contact a **RENAULT TRUCKS** service point or dealer.

Any modification to the installation may lead to vehicle malfunction.

Your vehicle is equipped with a radio/cassette player or a radio/mono CD player. To these two equipment items can be added a CD loader (8) and an infra-red remote control (9).

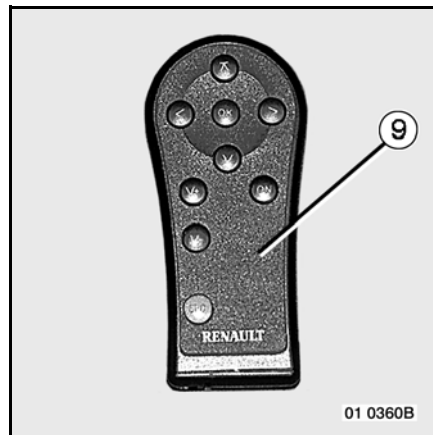
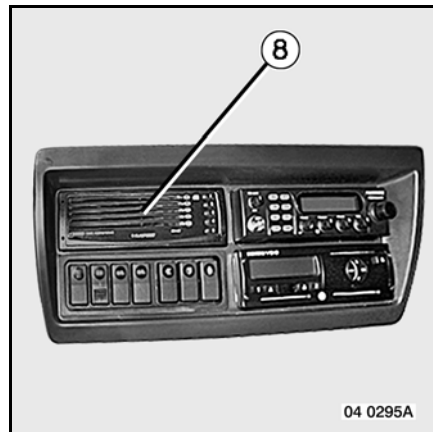

The radio is powered with a supply voltage of 24 Volts. It can be used when the ignition is switched off but the master switch must be engaged.

Anti-theft code

Your radio set is supplied with the code not activated.

B2-76 Presentation

B3-1 Presentation

Safety

Seat belts

Inertia reel seat belts

Slowly unwind the strap so as to be able to engage tongue (1) in buckle (2). If the strap jams, pull it back a little then continue unwinding.

Unlocking

Press button (3) on buckle (4); the belt is returned by the inertia reel. Accompany tongue (1) with your hand to facilitate this operation.

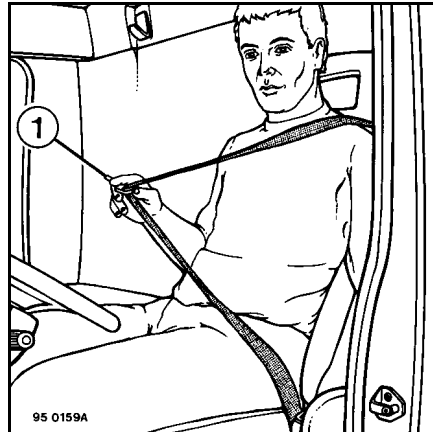

Depending on your vehicle's equipment

A buzzer will inform you when you have to attach your seat belt.



To ensure your own safety, wear your seat belt whenever you take the road. Before moving off: Firstly regulate your driving position, then adjust your seat belt correctly.

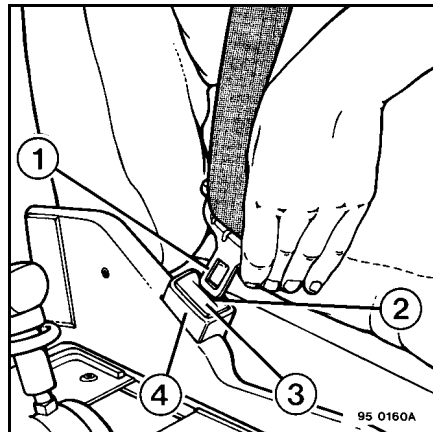

**BABIES OR CHILDREN SHOULD IN NO CIRCUMSTANCE BE CARRIED ON THE KNEES OF OCCUPANTS OF THE VEHICLE.
NEVER USE ONE SEAT BELT TO ATTACH TWO PERSONS.**



NEVER PASS THE SHOULDER STRAP UNDER YOUR ARM, OR BEHIND YOUR BACK.

B3-2 Presentation

Child safety

The use of devices for retaining babies and children is subject to regulations.

In Europe, children under 12 years old, with height below 1.50 metres and weighing less than 36 kilograms, must be attached with a type approved device suitable for the height and weight of the child.

The driver is responsible for correct use of such a device.

We recommend you to use a type approved device according to European regulation ECE 44.



*Comply with the laws in force in the country in which you are travelling.
They may differ from the indications given herein.*



**BABIES OR CHILDREN SHOULD IN NO CIRCUMSTANCE BE CARRIED ON THE KNEES
OF OCCUPANTS OF THE VEHICLE.**

NEVER USE ONE SEAT BELT TO ATTACH TWO PERSONS.

Before installing a child's seat in the front place (if installation is permitted)

If the passenger's seat is so equipped, proceed with the following adjustments:

- Move the passenger's seat as far back as possible.
- Straighten the seat squab as vertically as possible.
- Lower the seat cushion as low as possible.
- Raise the head-rest as high as possible.
- Place the seat belt height control in the low position.

B3-3 Presentation

Fire extinguisher

Depending on your vehicle's equipment

There is a fire extinguisher (1) near the driving position. Its exact location varies according to its capacity.

This appliance is subject to regulations. It must be inspected regularly by an approved body.



Wheel chocks

To remove the chock(s) (1) unhook securing straps (2). Upon assembly, ensure the correct position of chock(s) (1) and hook up the securing straps (2).

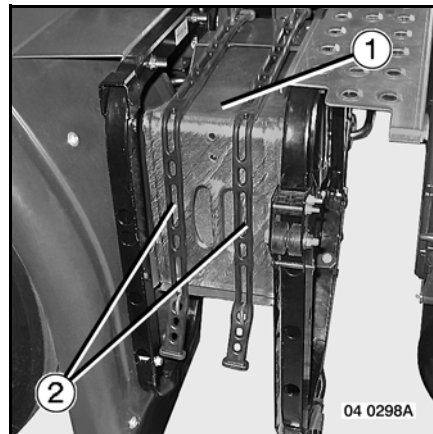

B3-4 Presentation

ADR vehicle (transport of dangerous materials)

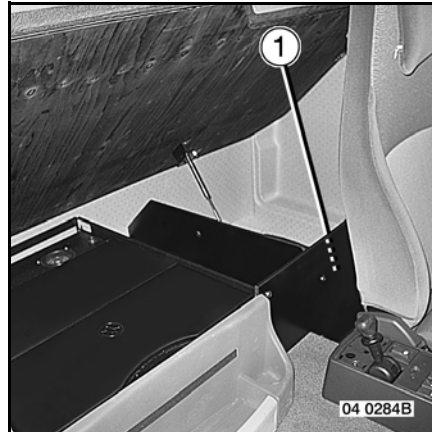

Depending on your vehicle's equipment

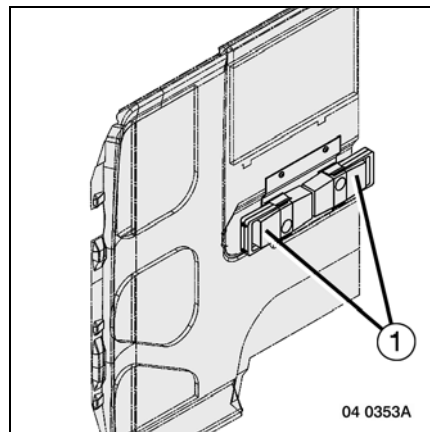
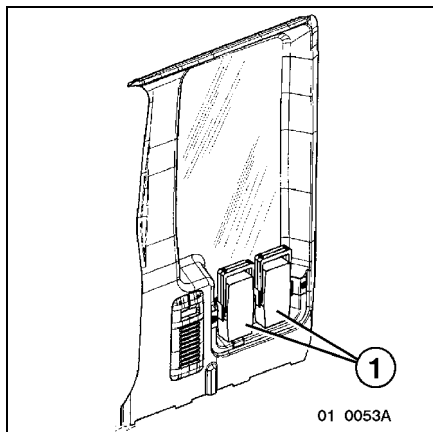

B3-5 Presentation

Self-contained lights (1).

Switch (2) features three positions:

A: orange flashing light.

B: off.

C: white steady light.

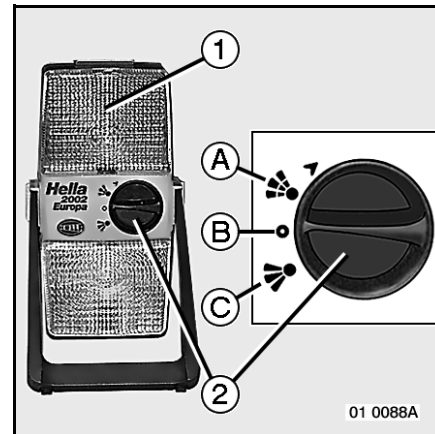

The self-contained lights are supplied without battery.

B3-6 Presentation

Life onboard

Movable ashtray:

Movable ashtray (1) must always be put back into one of the locations provided for that purpose, with the cover closed, after use.

Watch that this safety instruction is observed when the vehicle is moving or when the cab is being tilted.

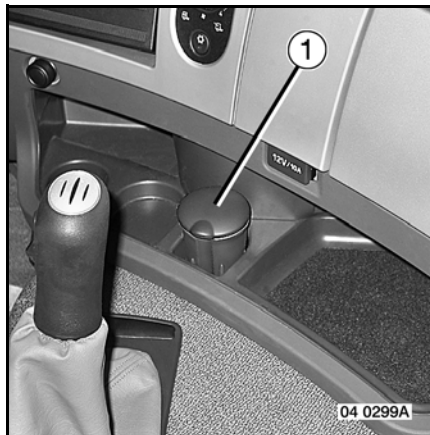

Comply with the maximum power ratings authorized for cab electrical sockets:

- 12V / 10A = 120W
- 24V / 15A = 360W



Never plug adapters into the cigar lighter.



It is strictly forbidden to store inflammable products in the cab.

B3-7 Presentation

Cab lighting

When you replace an overhead light bulb, replace it with a bulb with the same power rating and take care to refit the transparent cover without fail.



Location (1) is recommended for installing a mobile 'phone support bracket. Ensure that the fixing screws do not penetrate into the dashboard by more than 10 millimetres.



B3-8 Presentation

First aid kit

Depending on your vehicle's equipment
First aid kit location (1).

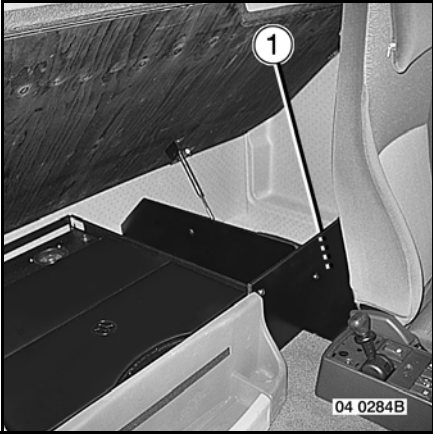
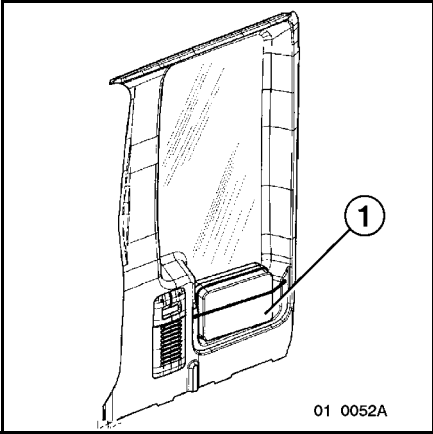

C1-1 Driving

Special conditions

Running-in

During the running-in period (5 000 km approximately), do not run the engine at maximum revs, except for short distances.

Do not use high engine speeds or allow the engine to labour at low or high speeds.

A careful watch should be kept on the water temperature gauge and the oil level.

The vehicle must be loaded as for normal operation.

Use during the winter or in cold climates

Engine starting

(see "Start-up" page C3-1)

Prior to driving away, allow the engine to run for a few seconds to ensure that oil circulation is established. It is best not to warm up the engine by prolonged running at idle or no-load, but, to drive it slowly using the lower gears until normal running temperature is achieved. Never demand maximum power from your engine until the coolant temperature reaches 80°C.



UNDER NO CIRCUMSTANCES SHOULD RADIATOR BLINDS OR SHUTTERS BE FITTED ON VEHICLES EQUIPPED WITH TURBOCHARGED INTERCOOLED ENGINES. SUCH ACCESSORIES PREVENT COOLING OF THE TURBOCHARGER AIR AND THUS REDUCE ENGINE EFFICIENCY, PERFORMANCE AND SERVICE LIFE.

Engine cooling system

This vehicle is supplied with "ULTRACOOLING PLUS" engine coolant (a Renault Trucks Oils product) conforming to the RENAULT TRUCKS specifications. It gives frost protection down to - 25 or - 40 °C.

Batteries

Keep the batteries fully charged since their resistance to frost depends on their state of charge.

C1-2 Driving

Use during the summer or in hot climates

Check the battery electrolyte level frequently. Do not labour the engine, change gear as often as necessary to maintain optimum engine speed. Thus, the circulation of water in the cooling system will be improved, keeping the engine temperature within the required specification limits. Frequently clean the exterior of the radiator by blowing compressed air through the core from the engine side, to remove any insects or dust that may restrict the air flow. Ensure that the radiator is in good condition and, if necessary, descale.

Use in dusty atmospheres

It is recommended to carefully inspect the air filter clogging indicator every day.

Air filter

Normal servicing (see page E6-6)

Do not forget that filter fouling depends on engine revs. If low gear ratios are constantly used (mountainous terrain), then the filter should be serviced on a time basis rather than mileage.

A blocked filter can cause serious damage.

Use at high altitude

The use of the vehicle at high altitudes affects engine performance. The reduction in power is in the region of 10% for naturally aspirated engines and around 5% for turbocharged engines for every 1,000 metres increase in altitude. In another connection, bear in mind that the boiling point of water decreases by 3.5°C every 1,000 metres increase in altitude.

C1-3 Driving

Economic driving

To obtain the very best performance from your gearbox, and more particularly lower fuel consumption, observe the following driving rules:

- Always choose the step-down ratio allowing you to use the engine at its best rotating speed. The maximum torque giving the lowest fuel consumption is to be found in that band.
- Choose the gear ratio in terms of the contour of the road.
- Remember that: **Any change in gear entails an increase in fuel consumption.**



For ADR vehicles, remove the flame trap outside sensitive zones in order to reduce fuel consumption.

Driving a solo tractor

Since the rear wheel grip is reduced because of the lack of load, drive carefully.

C1-4 Driving

Preheating the engine cooling system

Depending on your vehicle's equipment

The connector (1) serves to supply power to the cooling system preheater.

With the engine shut down, plug the electrical extension (2) from the onboard kit into the connector (1) to connect up with an external power source of 220 / 240 V 16 A meeting the standards in force.

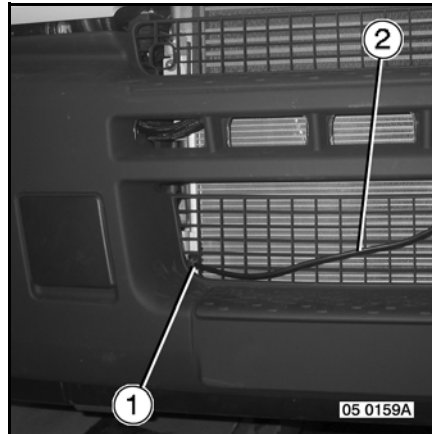

THERE IS LIVE 220 V CURRENT AT THE COOLING SYSTEM PREHEATER WHEN AN ELECTRICAL CORD IS PLUGGED INTO THE CONNECTOR.

Unplug the electrical extension and stow it away before using the vehicle.

C2-1 Driving

Prior to starting

Prior to getting into the vehicle

Check in particular:

- That there are no traces of oil, coolant or fuel under the vehicle.
- Oil levels:
 - engine
 - power steering
 - clutch
- Coolant level.



For further details on the various level checks, refer to the "checking levels" chapter, page(s) E2-1.

- Screen wash reservoir fluid level.
- Headlamp wash reservoir level.
- Tyre pressures.
- Air filter clogging indicator.
- That the connections between tractor and trailer have been made correctly.
- Cab locking system.
- Leaks from major units. Should a leak occur, clean the breather. A clogged breather allows pressure to build up in the casing and leads to leaks.

APM: Actuate the bleed valves to get rid of all water from the air tanks.

Carry out this operation:

- **Every day:** in winter.
- **Every week:** outside winter.

If not, get the APM checked out (see page E26-1).

C2-2 Driving

Engine oil level gauge

The oil level should be read on flat ground after the engine has been shutdown for a long period of time.

When the ignition is switched on and for around 30 seconds:

- If the oil level is correct, pictogram (G7) is displayed and a bargraph (1) shows the oil level.



The amount of oil (3) shown when the level is not at "max." corresponds to the volume of engine oil that must be added to reach that level.

This information is given for guidance. Topping up with oil is not vital as long as the oil level is above "min."

- If the oil level is correct, pictogram (G6) and a corresponding information text are displayed. A bargraph (1) shows the oil level.
- If the oil level is too low, bargraph (1) shows that the "min." level is reached and the indication (4) flashes.

The SERVICE warning light (I) comes on. It is vital to top up with oil as soon as possible.

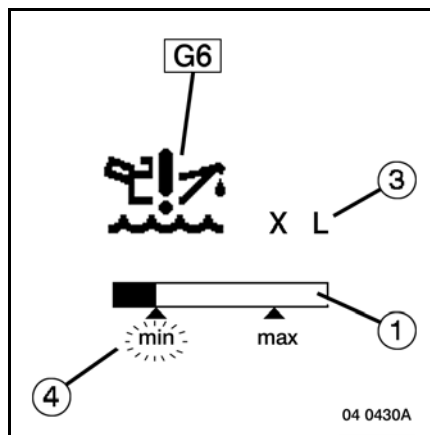
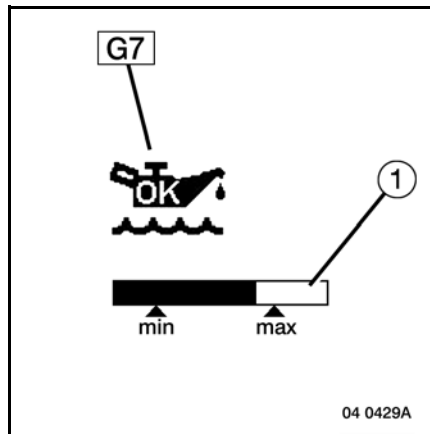

C2-3 Driving

- If the oil level is too high, bargraph (1) shows the "max." level has been exceeded and indication (5) flashes. The SERVICE warning light (I) comes on. Call upon a RENAULT TRUCKS service point or dealer without fail.

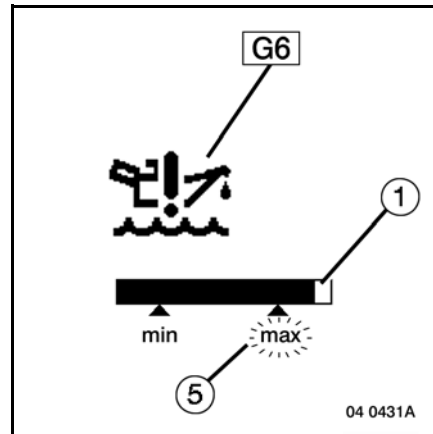

- If the oil level gauge is defective, pictogram (G8) and a corresponding information text are displayed. A full bargraph (1) is displayed, without the "min." and "max." indications. Check the oil level on the dipstick (see page E2-2) and make your way to the nearest RENAULT TRUCKS service point or dealer.

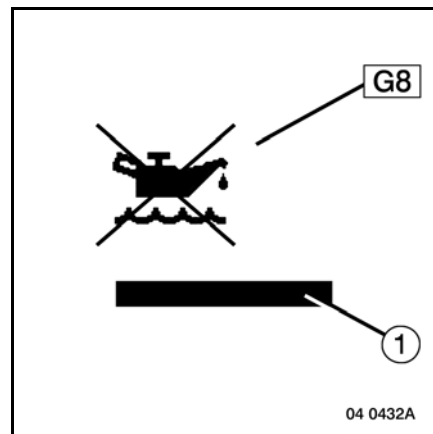

Fuel preheater

The fuel preheater starts up automatically.

A thermostat regulates its action according to the fuel temperature.

C2-4 Driving

Engine immobilizer

Depending on your vehicle's equipment

Starting switch with electronic anti-theft device

The vehicle is supplied with coded ignition keys paired up to the electronic anti-theft device. With the master switch engaged, insert the ignition key and turn it to the "ignition" position (3).

Warning light (G35) comes on for a few seconds, then goes out.

The system has recognized the key code number and authorizes engine start-up (key in "starting" position (4)).

"Starting impossible"

In the event of transponder malfunction, it is impossible to start the engine.

The message "**Starting impossible**" is shown on the information display.

Call upon the nearest RENAULT TRUCKS service point or dealer.

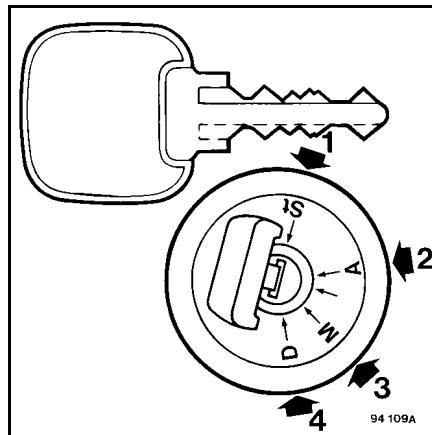

ANY FRAUDULENT ACTION ON THE ELECTRONIC IGNITION CUT-OFF SYSTEM WILL LEAD TO MALFUNCTION AND THIS REPRESENTS A REAL DANGER WHEN USING THE VEHICLE.

C2-5 Driving

Ignition switch

Ignition switch / steering lock

- "Engine stop and column lock" position (1): take out the ignition key and turn the steering wheel until the steering lock clicks.
- "Comfort accessories power supply" position (2): engine stopped, steering wheel free.
- "Ignition" position (3).
- "Starting" position (4).



To stop the engine, move the ignition key from position (3) to position (1).

If the key remains jammed, do not force it, but call in an electrician.

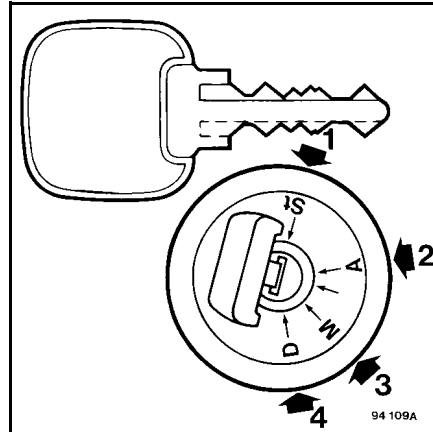

Display test

When the ignition is switched on, an auto-test runs for 4 seconds. This test serves to check all the instrument panel indicators for correct operation.

Regulatory test display

After the display test, the regulatory test mode is activated.

Depending on your vehicle's equipment, warning pictograms (G13 - G14 - G15 - G74) for the functions to be tested are displayed for about 3 seconds.

Warning pictogram (1) indicate that the vehicle is equipped with an ESP system.

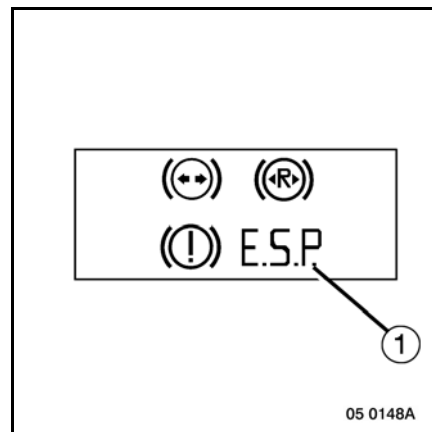

C2-6 Driving

Fault display

If there are any faults, one or several warning pictograms (1) are displayed on the instrument panel. In such case, the warning light (STOP or SERVICE) comes on simultaneously to specify the level of importance of the fault(s).

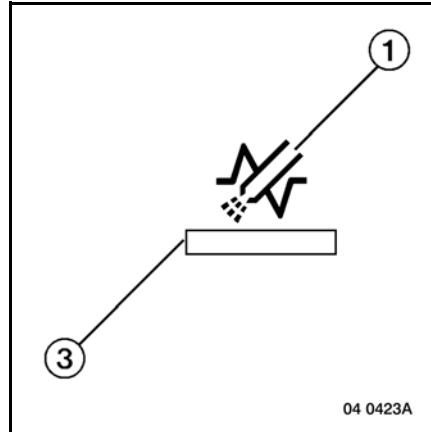

There are 2 possible cases:

- If the SERVICE warning light (I) comes on: you must, if possible, identify the problem and get it remedied or make your way to the nearest RENAULT TRUCKS service point or dealer.
- If the STOP warning light (H) comes on: you must, if possible, identify the problem and, where applicable, consult the nearest RENAULT TRUCKS service point or dealer.

If warning pictogram (G13) is displayed, start the engine so as to pressurize the compressed air circuit to see if it disappears. If it stays displayed, it may involve an EBS fault or a compressed air system problem.

If different faults are present (STOP and SERVICE), only STOP warning light (H) comes on.

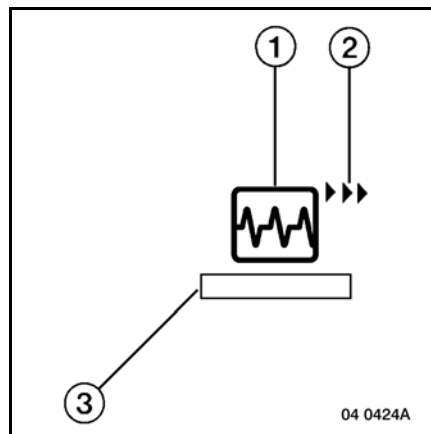

When several faults are present, arrows (2) appear and warning pictograms (1) (that depend on the nature of the fault) are displayed in succession, then offset to the top of the information display (see page B2-28).

A text (3), indicating the steps to take or information on the fault, is displayed below pictogram (1).

C2-7 Driving

Maintenance display

The maintenance alert pictogram may be displayed in 2 possible cases:

- As pre-alert, after the regulatory test, warning pictogram (G28) is displayed for around 30 seconds .
- As alert, warning pictogram (G28) is displayed and warning light (I) comes on. Make your way to the nearest RENAULT TRUCKS service point or dealer to get the maintenance carried out.

A text (3) specifies the type of maintenance to be carried out.

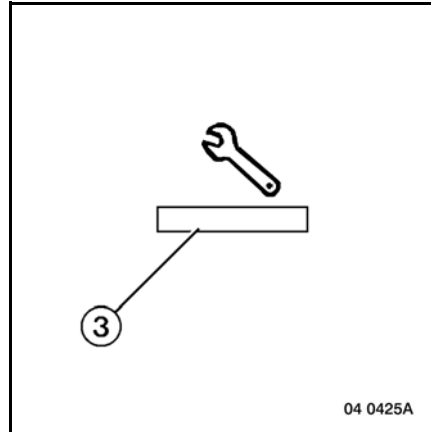

c2-8 Driving

C3-1 Driving

Start-up

Starting the engine



Depending on your vehicle's equipment, check that the engine cooling system preheater is disconnected. Do not start the engine if the preheater is connected for you run the risk of destroying the preheater resistor.

Make sure the parking brake is released.

Make sure the gear lever is in neutral.

Cancel the "Emergency stop" control by pressing switch (B4) (case of ADR vehicles for transport of hazardous substances).

Actuate the starter, without accelerating.

Temperatures below 5°C: the engine speed varies according to engine temperature and the "warm hold" function is activated (see page B-2-58).

Temperatures above 5°C: the engine speed varies according to engine temperature.

Temperatures below 0°C: Move the ignition key to position (3) (preheating), wait for warning light (X) to go out, turn the key to position (4) to actuate the starter and release the key as soon as the engine fires.

In all cases, the engine speed varies according to engine temperature.



The use of "Start pilote" type products (ether) for starting the engine is strictly forbidden (serious risk of spontaneous combustion or explosion).

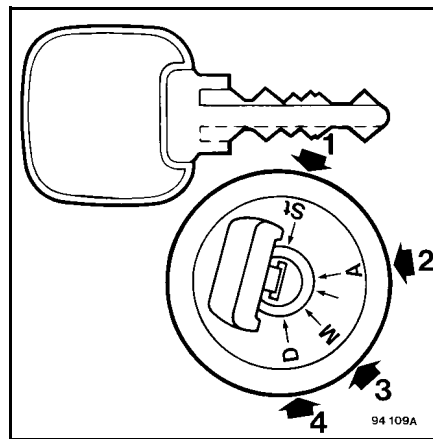
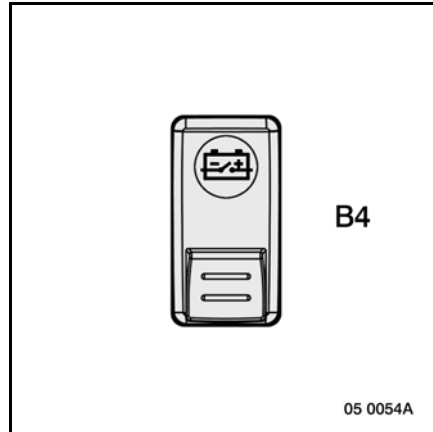

C3-2 Driving

Do not move away until:

- Brakes air pressure warning pictogram (G13) has disappeared and all circuits are operating correctly.
- You are certain that warning light (S) goes out when the parking brake lever is moved to the "road" position.



If the vehicle is equipped with a lift-up axle, warning light (P) stays on for as long as the axle is raised.

Depending on your vehicle's equipment

Check that there is no fault warning pictogram displayed on multi-function information display (L).

The symbol "N" (1) indicates that the gearbox is in neutral.

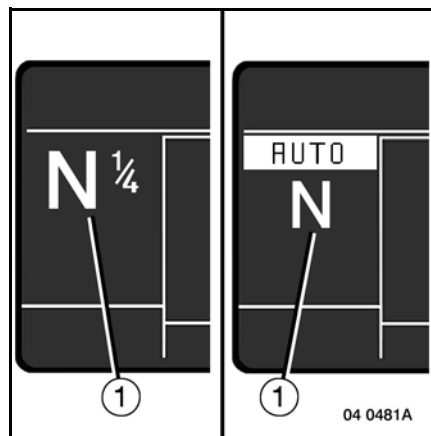

Depending on your vehicle's equipment

Vehicle equipped with an electric fuel preheater

Fuel preheating is controlled automatically according to the temperature of the fuel.

C3-3 Driving

Engine starting with pilot-controlled starter feature

Normal use:

Without accelerating, turn the key to position (4) and hold it there so that the starter drives the engine. Release the key in position (3) as soon as the engine fires.

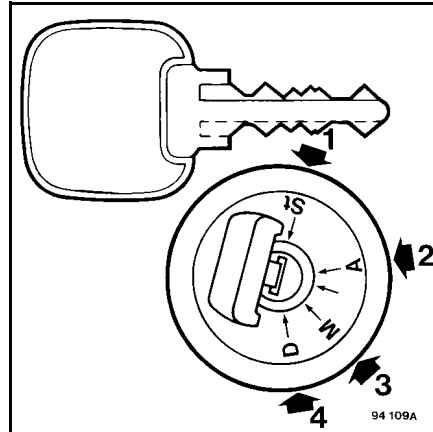

However, if the starter driving phase is interrupted before the engine starts and you want to re-activate the starter immediately, pictogram (G34) accompanied by a text (5) are displayed and requesting you to please wait. In this case, hold the key for 3 seconds in position (4) so that the starter again drives the engine. Release key in position (3) as soon as the engine fires.

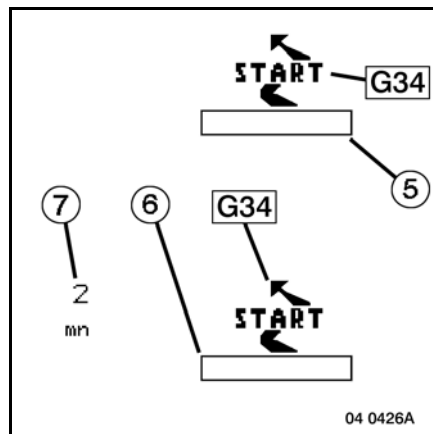

C3-4 Driving

Prolonged use:

The "pilot-controlled starter" function works according to an operating logic that prevents overheating of the starter and therefore avoids causing it serious damage.

The starter can drive the engine for 10 seconds followed by a 3 seconds break. Pictogram (G34) accompanied by a text (6), is displayed for these 3 seconds. This cycle can be repeated 4 to 5 times in succession by releasing the key in position (3) each time. After these 4 to 5 cycles, the starter enters into thermal protection mode. Pictogram (G34), accompanied by a text (6) informing you that the starter is in thermal safety mode and a countdown (7) are displayed.

As soon as indications (G34 - 6 - 7) disappear, it is possible to repeat 2 cycles, then the starter reverts to thermal protection mode and so on.

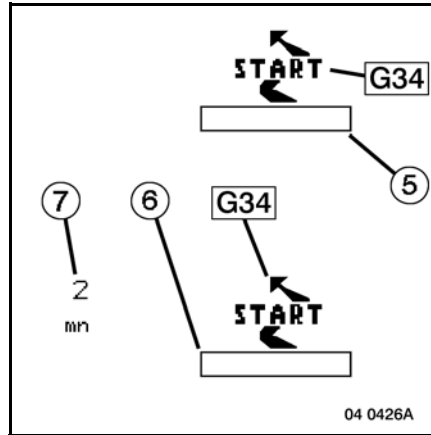

Forced running



The used of starter forced running is only permitted in case of danger (vehicle immobile on a level crossing, etc...). To do this, move the ignition key 3 times in less than 2.5 seconds from position (3) to position (4). This operation is kept in the memory and can be viewed using the RENAULT TRUCKS test tool.



IF YOUR VEHICLE IS EQUIPPED WITH A ZF GEARBOX, THE USE OF STARTER FORCED RUNNING INHIBITS THE "NEUTRAL" SAFETY FEATURE. MAKE SURE THE GEARBOX IS IN "NEUTRAL" OR RELEASE THE CLUTCH BEFORE ACTUATING THE STARTER.

C3-5 Driving

Engine idling speed adjustment device

Depending on your vehicle's equipment

This device serves to adjust the engine idling speed in a band lying between 590 and 650 rpm.

Use

With the vehicle stationary, parking brake engaged, engine idling, move control (A6) from "OFF" to "ON" at least 3 times in less than 2 seconds (OFF → ON → OFF → ON → OFF → ON).

With control (A6) in the "ON" position, adjust the new engine idling speed:

- press the "+" side of control (A7) to increase the engine speed;
- press the "-" side of control (A7) to reduce the engine speed.

Once you have defined the engine idling speed, depress the clutch pedal or the brake pedal and release it, to memorize the new engine speed and move control (A6) to the "OFF" position to quit the adjustment mode.

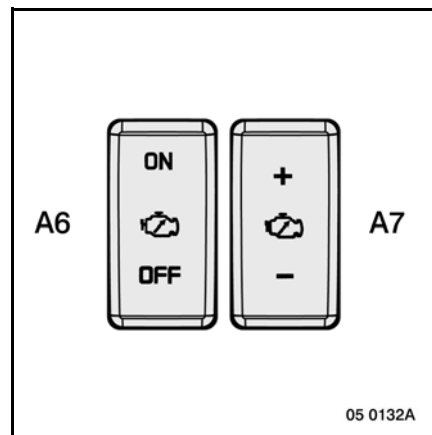

C3-6 Driving

Fast idling device

This device serves to control the engine idling speed when the vehicle is stationary.

Use

With the parking brake applied, gearbox in neutral, press the "ON" end of control switch (A6). To vary the engine speed, use control switch (A7).

Bring the engine to the required speed, using the accelerator pedal, and in that position, press the "-" end of control switch (A7) to memorize the engine speed.

Release the accelerator pedal.

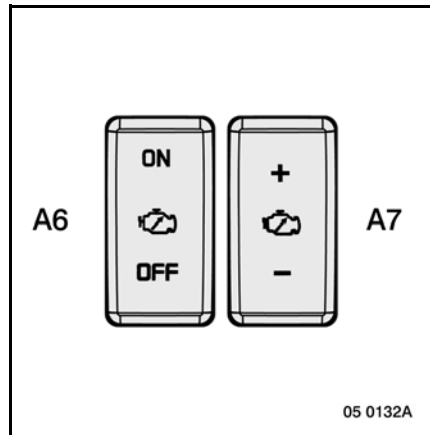

After activating the function by pressing the "ON" end of control switch (A6), press the "+" end of control switch (A7) to directly call up the nominal engine speed of 1000 rpm.

To fine tune the engine speed:

- Press the "+" end of control switch (A7) to gradually increase the engine speed.
Or dab the "+" end of control switch (A7) to increase the engine speed in increments.
- Press the "-" end of control switch (A7) to gradually reduce the engine speed.
Or dab the "-" end of control switch (A7) to reduce the engine speed in decrements.

Any action on the brake pedal, any gear changing or any pressing of the "OFF" end of control switch (A6) overrides the function.

Vehicle equipped with PTO(s)

When at least one PTO is in operation, the first action on control switch (A7) calls up the engine speed preset in the works (1000 rpm.).

This engine speed can be adjusted but is limited to 1500 rpm (see page(s) D1-20 or D1-21). Depending on the equipment fitted by the equipment manufacturer, the input conditions for this engine speed can be modified using the RENAULT TRUCKS test tool.



Avoid touching the accelerator pedal during use of the fast idling feature.

C4-1 Driving

On the road

Hydraulic power-assisted steering



When the engine is shut-down, power assistance to the steering is lost and between 5 and 7 times as much effort is needed to turn the steering wheel. In general, if loss of assistance is experienced, proceed as follows: Check the fluid level in the reservoir, check for leaks from hose and pipe unions and rectify if possible (tighten the unions or change the hoses). Top up the reservoir with clean fluid to the recommended specification. Restart the engine and check that the pump performs normally. Test at low engine and road speed.

If any doubt remains concerning the pump's efficiency, the unit must be inspected by an approved specialist.

Under no circumstances must hydraulic components be removed or their initial settings altered. This work must be carried out by a specialist.

A hydraulic system can only operate efficiently if it is kept perfectly clean. Great care must therefore be taken to ensure that no dirt enters the system when the above operations are carried out.

C4-2 Driving

Engine operating speed

Always choose the step-down ratio allowing you to use the engine at its best operating speed, in the green zone on the engine rev counter (T).

When you make use of retarder(s), a blue sector appears on the engine rev counter (T). This blue sector shows you the maximum efficiency band of the retarder(s).



**When the engine speed approaches to within 300 rpm of its maximum, a red zone rouge appears on the engine rev counter (T).
Never let the engine speed reach the red zone.**

C4-3 Driving

Cruise control



DO NOT USE THE CRUISE CONTROL ON SLIPPERY ROAD SURFACES

Above a speed of 30 km/h, this feature serves to travel at a steady speed without using the accelerator pedal.

If your vehicle is equipped with a retarder control with 2 to 5 setting positions.

When travelling downhill, the cruise control automatically pilots the different retarders in order to maintain the memorized speed.

A blue sector appears in zone (T) of the engine rev counter (V) to indicate the engine speed at which efficiency of the retarder(s) is optimal. Warning pictogram (1) or (2) also appears depending on the background colour selected for the information display (L).

If the retarders cannot maintain the set-point speed, the memorized speed flashes - use of the brakes is necessary.

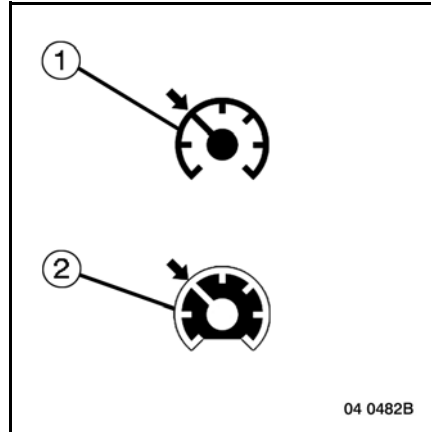

In this case, you are advised to memorize a lower speed and/or change down through the gears.

C4-4 Driving

Use

- Bring the vehicle to the desired road speed, using accelerator pedal, retarder control or service brake.



Upon activation of the cruise control or adjustment of the set-point speed, the information is displayed in large format in the main zone (2) of the information display. It is then displayed in zone (4) of the information display when the retarder is active ("ON").

- Press the steering wheel "ON/OFF" control switch.

The memorized speed (3) is displayed (by default, - - km/h).

- Press the "-" end of the control switch to memorize the speed.

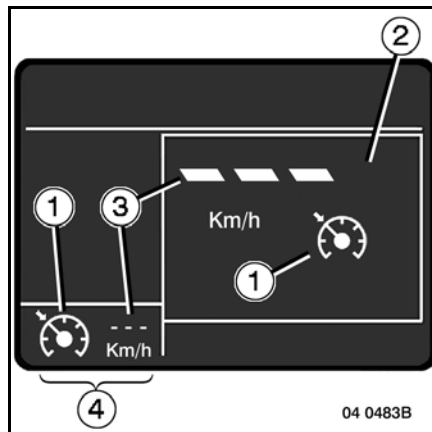

C4-5 Driving

To adjust your cruising speed:

- Press the "+" end of the control switch to increase the speed.
- Press the "-" end of the control switch to reduce the speed.
- A dab on the switch modifies the speed by 1 km/h.

Keeping the "+" end of the switch pressed varies the speed until the switch is released.

Keeping the "-" end of the switch pressed activates the retarders so as to slow the vehicle down faster .

At any moment, any action on the accelerator pedal serves to momentarily overstep the set speed.

Any action on the clutch pedal momentarily overrides the feature. Release the clutch pedal and the cruise control feature resumes automatically.

The feature is cancelled, pictogram (G39), item (1) disappears. the memorized speed remains displayed if:

- The road speed is below 15 km/h;
- You actuate the brake pedal or the retarder control, except on downhill sections, if the road speed remains less than 2 km/h higher than the cruise control speed.

In the event of slowing down to within ± 2 km/h of the memorized speed, pictogram (G39) flashes.

To return to the memorized road speed, press control switch "RES".

Pressing the "ON/OFF" switch cancels the function.



The cruise control is not a speed limiter and cannot be used as such.

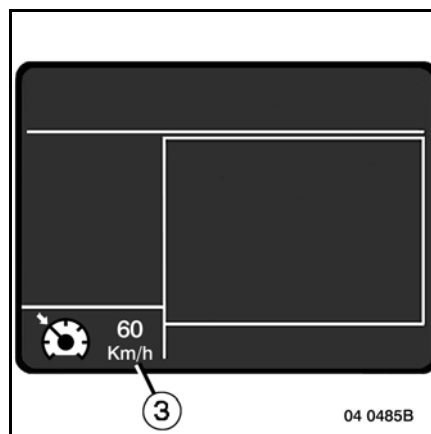
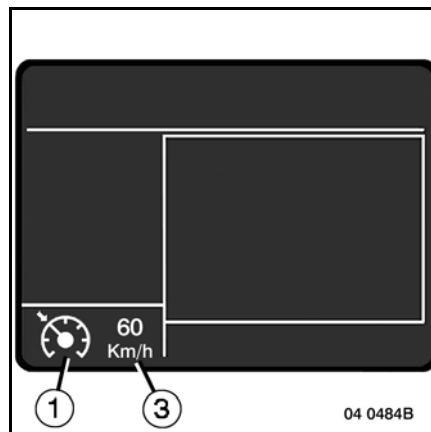

C4-6 Driving

Electronic speed limiter

Speed limitation is managed by the electronic fuel-injection system. In the event of malfunction, only RENAULT TRUCKS service points or dealers are empowered to take action.

Accelerator pedal

Depending on your vehicle's equipment

Vehicle equipped with "Optidriver 2" gearbox

By kicking through the slight hard spot at the end of the accelerator pedal travel, gearshifting management can be modified to obtain optimal mobility from your vehicle.



This feature accentuates fuel consumption.

C4-7 Driving

Retarder



Choose the step-down ratio allowing you to use the engine at its best speed. On hilly runs, use the retarder, if necessary.

Never drive downhill in neutral.

Do not use the retarder on slippery surfaces. Actuate switch (A4) to disable automatic operation.

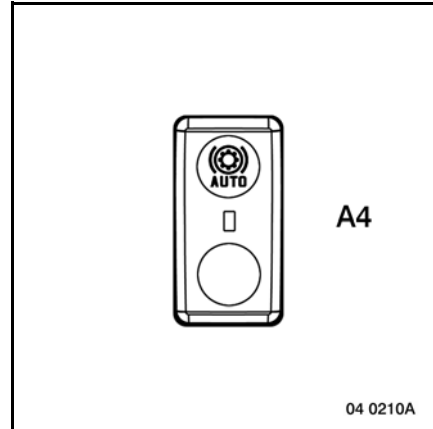

When the retarder function is active, a blue sector appears on the engine rev counter (T). This blue sector shows you the maximum efficiency band of the retarder(s). The engine-brake and propeller shaft retarder features are inhibited in the ABS and ESP phase.



Never let the engine speed reach the red zone (runaway speed).

C4-8 Driving

A single control under the steering wheel serves to activate the different retarders.

There are 4 possible options:

- Control with 1 active position: (see page C4-9). This serves to actuate the exhaust brake (with manual gearbox).
- Control with 2 active positions: (see page C-4-10). This serves to actuate the exhaust brake and the engine brake "optibrake" (with manual gearbox).
- Control with 3 active positions: (see page C-4-12). This serves to actuate the exhaust brake and the engine brake "optibrake" (with Optidriver 2 gearbox).
- Control with 5 active positions: (see page C-4-14). This serves to actuate the exhaust brake, the engine brake "optibrake" and the hydraulic retarder.

Switch

A = Not activated:

- Manual operation (see page C4-9).

B = Activated:

- Retarder coupling to foot brake (main brake).

The exhaust brake, engine brake and prop shaft retarder feature is activated whenever the foot brake pedal is actuated, if the retarder control lever (1) is in position "0".



The retarder feature is inhibited for the first 5 times the brake pedal is depressed after the ignition is switched on.

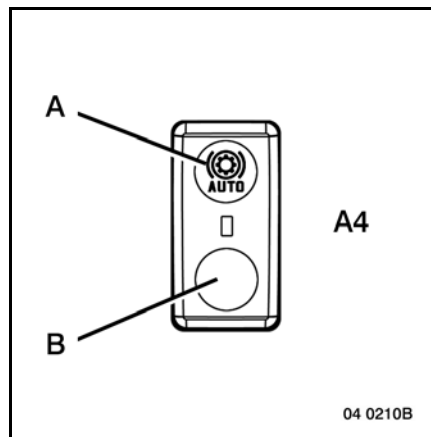

The retardation power is modulated according to the vehicle load and the pressure exerted on the brake pedal. Warning light (Q) is out.

Coupling of retarder with cruise control (constant speed)

Warning light (Q) comes on and a blue sector appears on the rev counter (T), if the prop shaft and/or engine-brake functions are active (see page C4-3).



C4-9 Driving

Exhaust brake (with manual gearbox)

Depending on your vehicle's equipment

Use the gear combinations to choose the down-hill speed according to the gradient. To slow the vehicle, release the accelerator pedal and move control lever (1).

– **Position 0:**

The feature is not active: the warning light (Q) together with the rev counter blue sector (T) are extinguished.

– **Position 1 with action on the accelerator pedal:**

The engine brake feature is preselected but is not active: the rev counter blue sector (T) is illuminated.

– **Position 1 without action on the accelerator pedal:**

Above 900 rpm, the engine brake feature is active: warning light (Q) together with the rev counter blue sector (T) are illuminated.

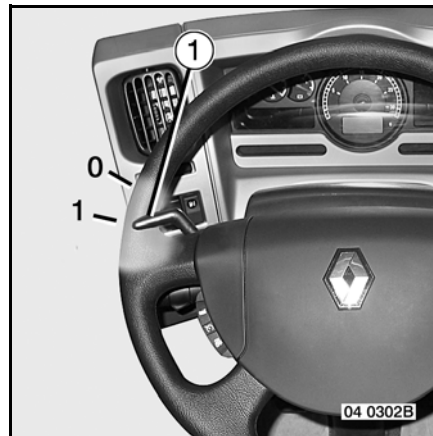

This blue sector indicates the maximum efficiency band of the retarder.



Never let the engine speed reach the red zone (runaway speed).

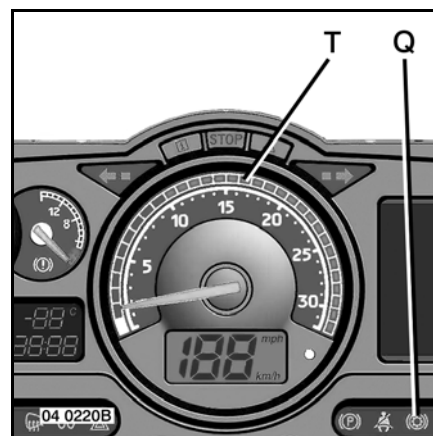

C4-10 Driving

Exhaust brake with engine brake "OPTIBRAKE" (with manual gearbox)

Depending on your vehicle's equipment

Use the gear combinations to choose the down-hill speed according to the gradient. To slow the vehicle, release the accelerator pedal and move control lever (1).

– **Position 0:**

The feature is not active: the warning light (Q) together with the rev counter blue sector (T) are extinguished.

– **Position 1 with action on the accelerator pedal:**

The engine brake feature is preselected but is not active: the rev counter blue sector (T) is illuminated.

– **Position 1 without action on the accelerator pedal:**

The exhaust brake plus engine brake feature is active at about 50% torque efficiency depending on the vehicle load: warning light (Q) together with the rev counter blue sector (T) are illuminated.

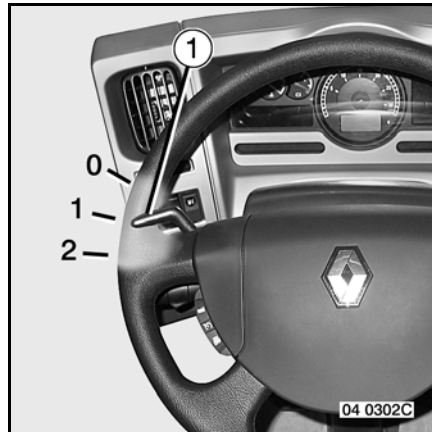

This blue sector indicates the maximum efficiency band of the retarder.



Never let the engine speed reach the red zone (runaway speed).

– **Position 2 with action on the accelerator pedal:**

The exhaust brake plus engine brake feature is preselected but is not active: the rev counter blue sector (T) is illuminated.

– **Position 2 without action on the accelerator pedal:**

The exhaust brake plus engine brake feature is active at 100% torque efficiency: warning light (Q) together with the rev counter blue sector (T) are illuminated.



This blue sector indicates the maximum efficiency band of the retarder.

C4-11 Driving



Never let the engine speed reach the red zone (runaway speed).



C4-12 Driving

Exhaust brake and exhaust brake "OPTIBRAKE" (with Optidriver 2 gearbox)

Depending on your vehicle's equipment

Use the gear combinations to choose the down-hill speed according to the gradient. To slow the vehicle, release the accelerator pedal and move control lever (1).

– **Position 0:**

The exhaust brake plus engine brake feature is not active: the warning light (Q) together with the rev counter blue sector (T) are extinguished.

– **Position 1 with action on the accelerator pedal:**

The exhaust brake plus engine brake feature is preselected but is not active: rev counter blue sector (T) is illuminated.

– **Position 1 without action on the accelerator pedal:**

The exhaust brake plus engine brake feature is active at about 50% torque efficiency depending on the vehicle load: warning light (Q) together with the rev counter blue sector (T) are illuminated.

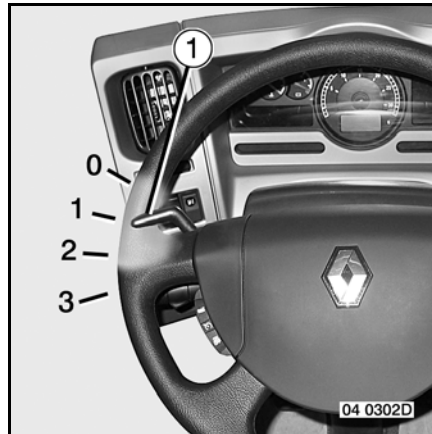

This blue sector indicates the maximum efficiency band of the retarder.



Never let the engine speed reach the red zone (runaway speed).

– **Position 2 with action on the accelerator pedal:**

The exhaust brake plus engine brake feature is preselected but is not active: the rev counter blue sector (T) is illuminated.

– **Position 2 without action on the accelerator pedal:**

The exhaust brake plus engine brake feature is active at 100% torque efficiency: warning light (Q) together with the rev counter blue sector (T) are illuminated.



This blue sector indicates the maximum efficiency band of the retarder.

C4-13 Driving



Never let the engine speed reach the red zone (runaway speed).

- **Position 3 (MAX mode activated) with action on the accelerator pedal:**

The exhaust brake plus engine brake feature is preselected but is not active: rev counter blue sector (T) is illuminated.

- **Position 3 (MAX mode activated) without action on the accelerator pedal:**

The exhaust brake plus engine brake feature is active at 100% torque efficiency: warning light (Q) together with the rev counter blue sector (T) are illuminated.



This blue sector indicates the maximum efficiency band of the retarder.



Never let the engine speed reach the red zone (runaway speed).



The engagement of "MAX" mode initiates downshifting of the Optidriver 2 gearbox, enabling the engine speed to be raised and thus increase retardation. This position is unstable.

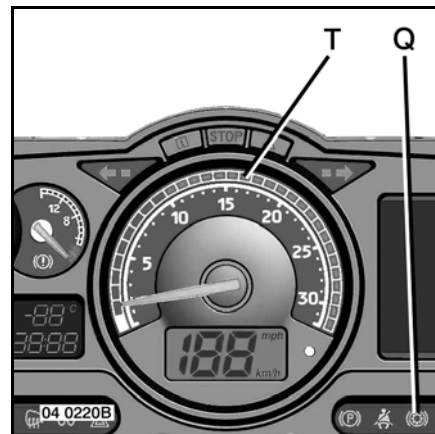

C4-14 Driving

Exhaust brake with engine brake "OPTIBRAKE" coupled with a VOITH hydraulic retarder (with Optidriver 2 gearbox)

Depending on your vehicle's equipment

Use the gear combinations to choose the down-hill speed according to the gradient. To slow the vehicle, release the accelerator pedal and move control lever (1).

5-position control: except in case of absolute need, never move control directly from position 0 to position 5.

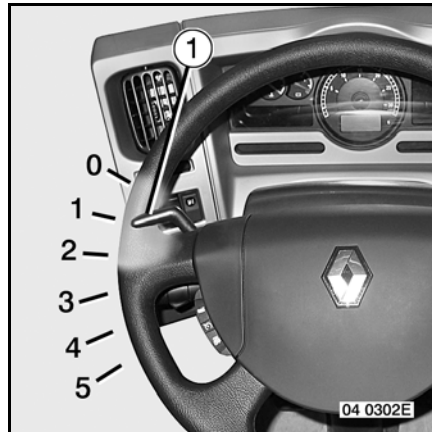

– **Position 0:**

The feature is not active: the warning light (Q) together with the rev counter blue sector (T) are extinguished.

– **Position 1 with action on the accelerator pedal:**

The exhaust brake, engine brake plus prop shaft retarder feature is preselected but is not active: the rev counter blue sector (T) is illuminated.

– **Position 1 without action on the accelerator pedal:**

The exhaust brake, engine brake plus prop shaft retarder feature is active at about 25% torque efficiency depending on the vehicle load: warning light (Q) together with the rev counter blue sector (T) are illuminated.

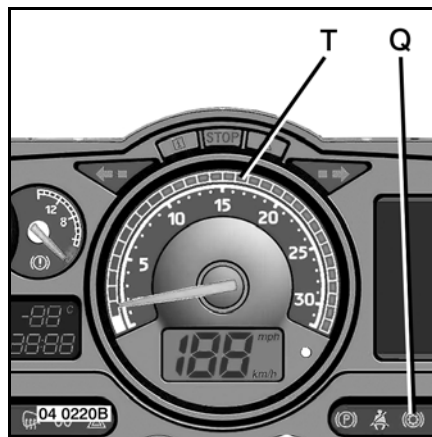

This blue sector indicates the maximum efficiency band of the retarder.

C4-15 Driving



Never let the engine speed reach the red zone (runaway speed).

– **Position 2 with action on the accelerator pedal:**

The exhaust brake, engine brake plus prop shaft retarder feature is preselected but is not active: the rev counter blue sector (T) is illuminated.

– **Position 2 without action on the accelerator pedal:**

The exhaust brake, engine brake plus prop shaft retarder feature is active at about 50% torque efficiency depending on the vehicle load: warning light (Q) together with the rev counter blue sector (T) are illuminated.



This blue sector indicates the maximum efficiency band of the retarder.



Never let the engine speed reach the red zone (runaway speed).

– **Position 3 with action on accelerator pedal:**

The exhaust brake, engine brake plus prop shaft retarder feature is preselected but is not active: the rev counter blue sector (T) is illuminated.

– **Position 3 without action on accelerator pedal:**

The exhaust brake, engine brake plus prop shaft retarder feature is active at about 75% torque efficiency depending on the vehicle load: warning light (Q) together with the rev counter blue sector (T) are illuminated.



This blue sector indicates the maximum efficiency band of the retarder.



Never let the engine speed reach the red zone (runaway speed).

C4-16 Driving

- **Position 4 with action on accelerator pedal:**

The exhaust brake, engine brake plus prop shaft retarder feature is preselected but is not active: the rev counter blue sector (T) is illuminated.

- **Position 4 without action on accelerator pedal:**

The exhaust brake, engine brake plus prop shaft retarder feature is active at 100% torque efficiency: warning light (Q) together with the rev counter blue sector (T) are illuminated.



This blue sector indicates the maximum efficiency band of the retarder.



Never let the engine speed reach the red zone (runaway speed).

- **Position 5 (MAX mode activated) with action on accelerator pedal:**

The exhaust brake, engine brake plus prop shaft retarder feature is preselected but is not active: the rev counter blue sector (T) is illuminated.

- **Position 5 (MAX mode activated) without action on accelerator pedal:**

The exhaust brake, engine brake plus prop shaft retarder feature is active at 100% torque efficiency: warning light (Q) together with the rev counter blue sector (T) are illuminated.



This blue sector indicates the maximum efficiency band of the retarder.

C4-17 Driving



Never let the engine speed reach the red zone (runaway speed).



The engagement of "MAX" mode initiates downshifting of the Optidriver 2 gearbox, enabling the engine speed to be raised and thus increase retardation. This position is unstable.

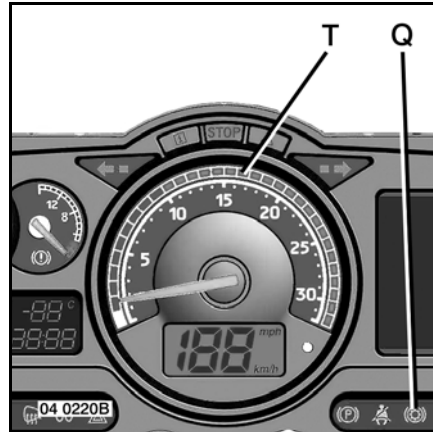

C4-18 Driving

Exhaust brake with or without engine brake "OPTIBRAKE" coupled with a ZF hydraulic retarder (with ZF gearbox)

Depending on your vehicle's equipment

Use the gear combinations to choose the downhill speed according to the gradient. To slow the vehicle, release the accelerator pedal and move control lever (1).

Control with 5 positions: except in case of absolute need, never move control (1) directly from position 0 to position 5.

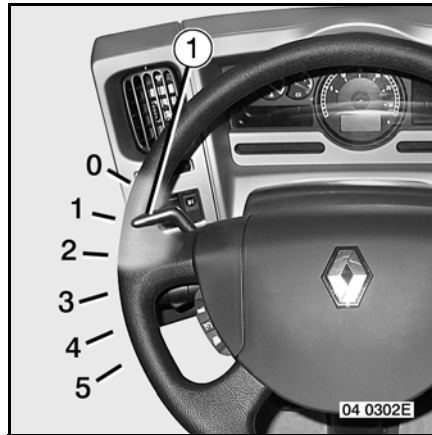

– **Position 0:**

The feature is not active: the warning light (Q) together with the rev counter blue sector (T) are extinguished.

– **Positions 1 to 5 with action on accelerator pedal:**

The exhaust brake, engine brake and prop shaft retarder feature is pre-selected but not active: the rev counter blue sector (T) is illuminated.

– **Positions 1 to 5 without action on accelerator pedal:**

The prop shaft plus engine brake retarder feature is active with a progressive increase in power according to the position of control (1): warning light (Q) together with the rev counter blue sector (T) are illuminated.

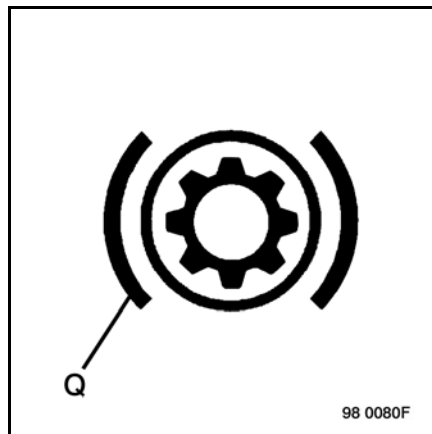

C4-19 Driving

To optimize cooling of the hydraulic retarder on steep downhill runs, keep the engine speed above 1500 rpm.



This blue sector indicates the maximum efficiency band of the retarder.



Never let the engine speed reach the red zone (runaway speed).

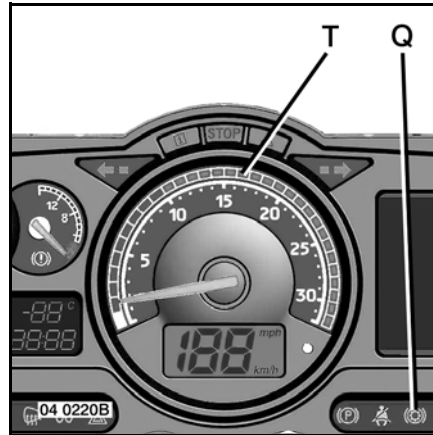

C4-20 Driving

Driving Monitoring System

For vehicles equipped with a ZF gearbox, a device called "Driving Monitoring System" determines then suggests the best gear to be engaged in order to optimize the use of your engine and gearbox. Several information items appear on the display (L) to guide you while driving. The "DMS" suggestions take into account vehicle load, road gradient and accelerator pedal position. In such case, favour the "DMS" suggestion over use of the rev counter zone (T).



The "DMS" system cannot anticipate the contour of the road (approaching a slope, downhill section, etc...). In such case, it is advisable to not follow the "DMS" suggestion unerringly

C4-21 Driving

Operation

Since the gear engaged is higher than 2nd low, the "gear engaged" information (1) and the position of the splitter (low range warning light (2) or high range warning light (3)) are displayed only when:

- the vehicle is running, accelerator pedal depressed;
- a retarder is in service and there is no action on the accelerator pedal;
- there is no action (even slight) on the clutch pedal.

When it is necessary to change gear and/or shift the splitter, the "recommended gear" (4) information and the recommended splitter position light (5) are displayed.

Only during changing up does a "bleeper" sound accompany the display of this information. This beeping sound avoids you having to permanently keep an eye on the display for notification of a new recommendation, but it does not sound when a second recommendation is displayed if the first recommendation has not been followed.

Several combinations of recommendations are possible (see page C-4-22).

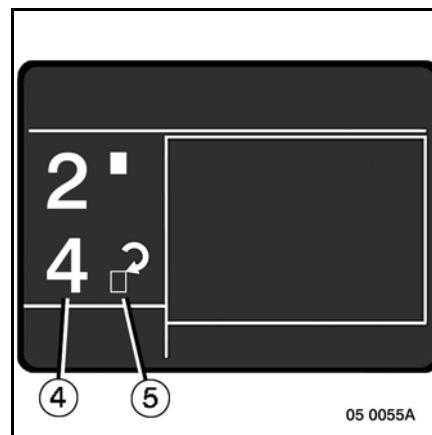
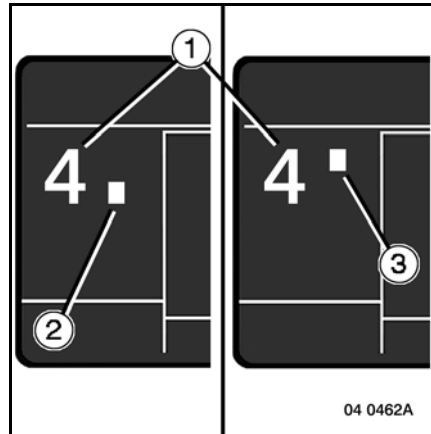

C4-22 Driving

Suggestion (1)

Shift the splitter to high range without changing gear.

Suggestion (2)

Shift the splitter to low range without changing gear.

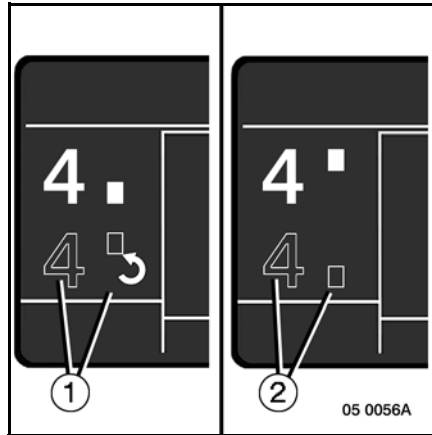

Suggestion (3)

Engage the gear shown while leaving the splitter in low range.

Suggestion (4)

Engage the gear shown while leaving the splitter in high range.



Splitter light (3 - 4) empty: no change in splitter position. Splitter light (5 - 6) full: change in splitter position.

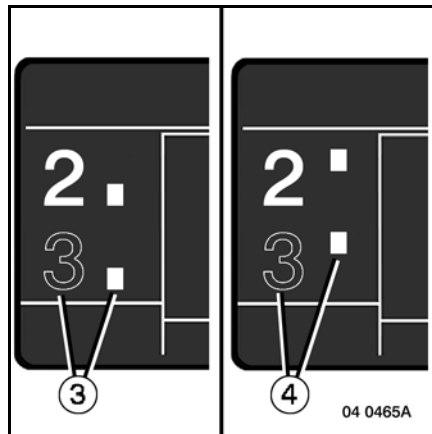

Suggestion (5)

Engage the gear shown and shift the splitter to high range.

Suggestion (6)

Engage the gear shown and shift the splitter to low range.

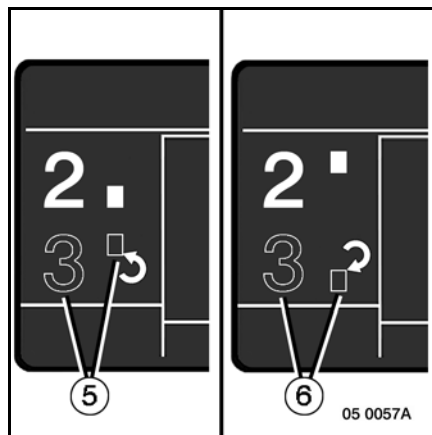

C4-23 Driving

Suggestion (7)

Engage a suitable higher gear.



*The "bleep" can be adjusted
(see page B-2-40).*

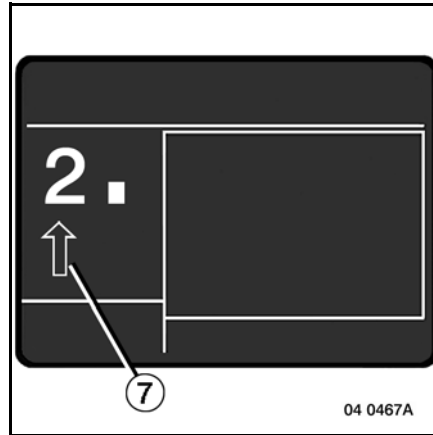

C4-24 Driving

Manual gearbox

Depending on your vehicle's equipment



The gearboxes are fitted with an oil pump for lubrication, therefore coasting downhill in neutral (free-wheeling) will cause rapid damage to the gearbox (for towing, see page F-8).

Always move away in first gear, then change through the gears in a regular sequence to prevent premature wear of the clutch.

Changing gear

Gear pattern

Gearbox

Driving

Since the gearbox is synchronized, gear changes should be made without double-declutching or double-peddalling.

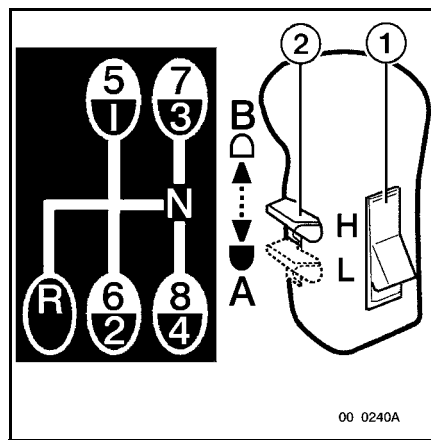

The gear pattern is a single superimposed H.

The "high range" plane is superimposed on the "low range" plane. There is one single neutral position which is automatically situated in the 3rd/4th gear plane of the low range or in the 7th/8th gear plane of the high range.

The range is selected by the selector (2), position A low range, position B high range, as follows:

- If the gear lever is in neutral, with the vehicle at a standstill, the splitter shifts immediately.
- If a gear is engaged, the splitter moves to neutral before engaging a gear.

To change down from 5th gear to 4th gear, the vehicle speed must be lower than 30 km/h (forbidden by safety device)

To change down from 3rd gear to 2nd gear, the vehicle speed must be lower than 15 km/h. For safety reasons, the manoeuvre is nevertheless possible, but requires great force to be exerted on the gear lever (Warning: risk of damage to gearbox, engine and clutch).



When you are in splitter high range and you *inadvertently or accidentally* select low range, the splitter will not shift if the vehicle speed is higher than 30 km/h.

C4-25 Driving

Below this speed, it is possible to change down from 6th gear to 1st gear, but with risk of overspeed that may cause damage to engine, clutch and gearbox.

This manoeuvre goes against good driving practice and is strictly forbidden.

State of "low/high range" splitter.

In neutral, when "low range" is selected, the indication (3) is displayed and when "high range" is selected, the indication (4) is displayed.

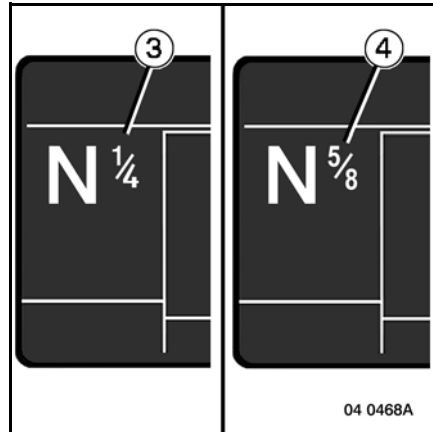

The splitter can be shifted from "low/high" range and vice versa at all speeds and to do so, proceed as follows:

Flip the gear lever switch (1) to position "H", fully depress the clutch pedal, release the clutch pedal: splitter high range is engaged and warning indication (5) is displayed while it is in use.

To engage splitter low range, flip the gear lever switch (1) to position "L", fully depress the clutch pedal, release the clutch pedal: splitter high range is engaged and warning indication (6) is displayed while it is in use.

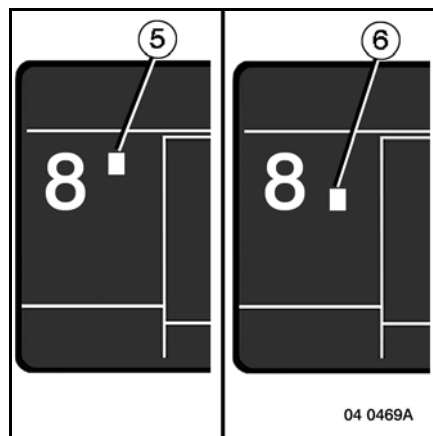

Pre-select splitter "low/high" range: the splitter changes from low to high range, and vice versa, only when the clutch is depressed.



It is advised against using the reverse gear when the selector is in position B (high range), except in special circumstances (vehicle unladen, over a short distance, flat ground, in a straight line and on a good surface).

C4-26 Driving

Optidriver 2 gearbox

Depending on your vehicle's equipment



The gearboxes are fitted with an oil pump for lubrication, therefore coasting downhill in neutral (free-wheeling) will cause rapid damage to the gearbox (for towing, see page F-8).

"Optidriver 2" system

The "Optidriver" system makes it possible to automatically determine, then engage a gear suited to vehicle load, road contour, accelerator pedal position and activation or not of the retarders. It improves driving smoothness and safety by reducing driver fatigue, as he no longer has to concentrate on traffic conditions.

The **Optidriver 2** system can be used in 2 different ways: in integral automatic mode or in manual mode. You are strongly advised to use the integral automatic mode in order to benefit from optimum management of the powertrain. In the event of system trouble, you can benefit from a fall-back (limp home) mode.

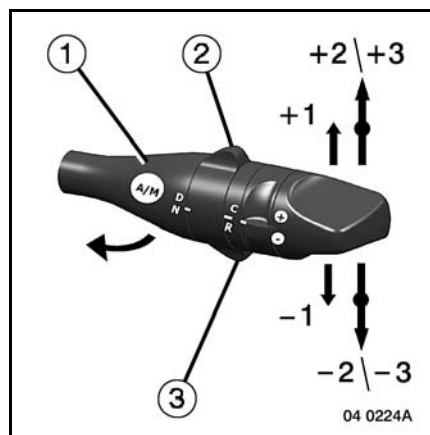

C4-27 Driving

First contact with Optidriver 2

Start-up

With ring (2) of selector (1) in the "neutral" position and the line on the ring opposite indication "N".

Start the engine.

With the parking brake engaged, move the ring (2) to position "D".

The moving away gear is engaged.

Depress the brake pedal and release the parking brake.

Release the brake pedal and depress the accelerator pedal: the vehicle moves forwards.

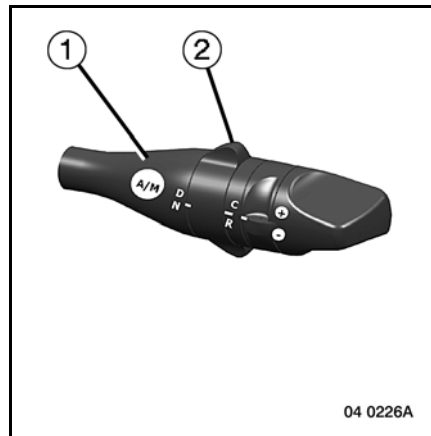

It is recommended to not change the position of the accelerator pedal when changing gear.



The system refuses to engage gears that may lead to overspeed.

Manoeuvring

Changing into 1st gear

With the vehicle at a standstill: move the ring (3) of selector (1) to position "C" .

Changing into reverse gear

With the vehicle at a standstill: move the ring (3) of selector (1) to position "R".

The system engages reverse low range reverse gear R1. With reverse gear engaged: nudge the selector rearwards (-) to shift from R1 to R2 (or from R2 to R3) and forwards (+) to shift from R2 to R1 or from R3 to R2.

Shifting from R3 to R4 or from R1 to R2 can be carried out while the vehicle is moving.

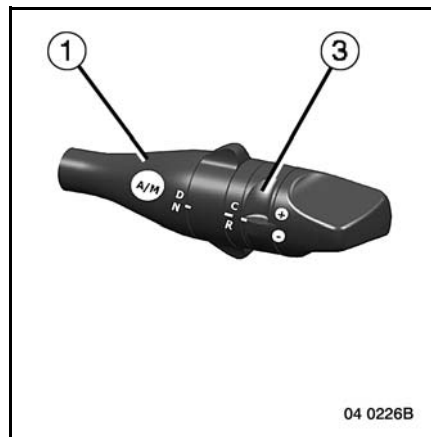

High range reverse gears R3 and R4 should not be used for manoeuvring. It is recommended to not move away in R4.

C4-28 Driving



When you change to reverse gear, the information "Manu" (4) and "R" (5) are displayed. Conduct your manoeuvre and move the gear selector (1) in the direction of mark "AM" to change over to integral automatic mode.

Manoeuvring mode

To easily couple or uncouple a semi-trailer, adjust the trailer landing legs so that the load on the tractor fifth wheel is minimal (see page D1-2).

Stopping

Move the ring (2) of selector (1) to position "N" to change the gearbox into neutral and apply the parking brake before leaving the vehicle .



When the engine is shut-down, the gearbox is in neutral, so it is impossible to change gears.

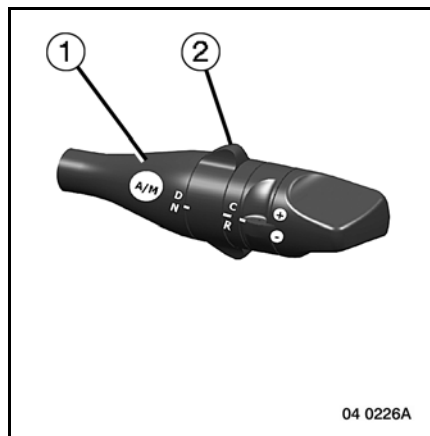
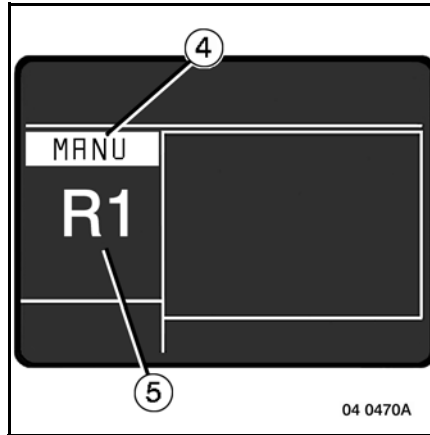

C4-29 Driving

Description of Optidriver 2

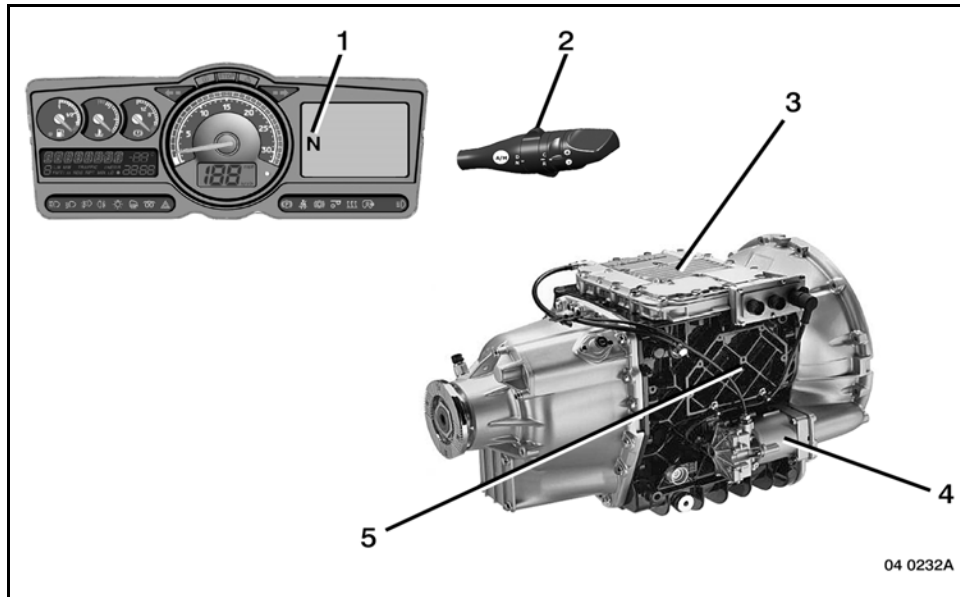

The Optidriver 2 gearbox consists of 5 major components:

- A dedicated zone on information display (1),
- A gear selector (2) with integrated ECU,
- A gearshift control module (3) with integrated ECU,
- A clutch control device (4),
- A manual gearbox incorporating dog clutches (5).

C4-30 Driving

Gear selector (1)

The selector (1) can be moved in 3 directions for driving and is provided with 2 rings (2 - 3) for changing into neutral and for the "manoeuvring mode":

Ring (2): positions "N" / "D"

Move the ring to position "N". The gearbox changes into neutral.

Move the ring to position "D". The gearbox engages the moving away gear.

Ring (3): positions "C" / "R" ("manoeuvring mode")

Move the ring to position "D". The gearbox engages 1st forward gear.

Move the ring to position "R". The gearbox engages 1st reverse gear.

Pull the selector towards yourself ("A/M") to quit the "manoeuvring" mode.

Nudging the selector forwards (parallel to the steering wheel): to position "+" serves to correct the automatic driving mode for changing into higher gears.

Nudging the selector rearwards (parallel to the steering wheel): to position "-" serves to correct the automatic driving mode for changing into lower gears.

Pulling the selector briefly towards yourself ("flashing headlights" style): to position "A/M"

Pull the selector briefly to change from automatic mode to full-time manual mode and vice versa.

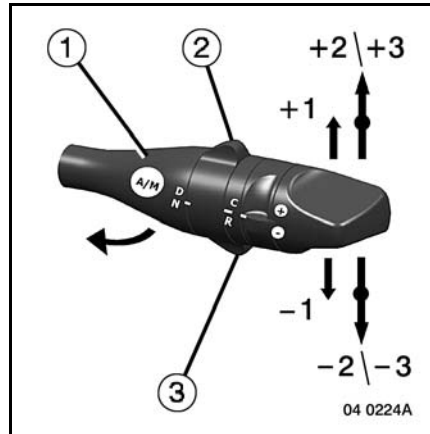

Moving away

Ring (2) in the "neutral" position.

Start the engine.

With the parking brake applied, move the ring (2) to position "D".

The moving away gear is engaged.

Depress the brake pedal and release the parking brake.

Release the brake pedal and depress the accelerator pedal: the vehicle moves forwards.

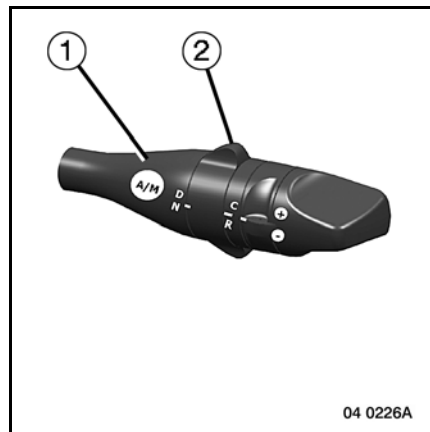

C4-31 Driving



If the accelerator pedal is not depressed after the parking brake is released, the vehicle may move forwards: use the brake pedal to hold it on the service brake.

Moving away gear

Move the ring (2) of selector (1) from position "N" to position "D".

In automatic mode, the system engages the optimal gear in relation to vehicle load and road contour.



The system serves to select moving away gears only as high as 6th low.



It is possible to change the moving away gear, but the use of an unsuitable higher gear may lead to premature clutch wear.

Moving away uphill

Start the engine; the correct moving away gear will be engaged upon changeover to mode "D".

Depress the brake pedal and release the parking brake.

The vehicle moves forward.



YOUR VEHICLE MAY BE EQUIPPED WITH A "HILL-START CONTROL" TO HELP IN MOVING AWAY ON UPHILL GRADIENTS. WHEN THIS FEATURE IS ACTIVATED (SWITCH (A2)), THE BRAKES ARE KEPT APPLIED FOR 1 SECOND AFTER THE BRAKE PEDAL IS RELEASED. IF NO ACTION IS TAKEN BEFORE THIS PERIOD ELAPSES (ACCELERATION, BRAKE PEDAL APPLIED AGAIN), THE BRAKES WILL NO LONGER BE KEPT APPLIED AND THE VEHICLE WILL START TO ROLL BACKWARDS.

See page C-4-45

C4-32 Driving

Moving away on gradients

Start the engine: the correct moving away gear will be engaged upon changeover to mode "D".

Release the parking brake.

The vehicle moves forward (the clutch engages).



If you move the selector from position "N" to position "D" while the vehicle is moving forwards: the system chooses a gear suited to the travelling speed and the clutch engages.



It is forbidden to let the vehicle move backwards with the gear selector in neutral.

Changing into neutral

The gearbox changes automatically into neutral when the ignition is switched on or switched off (engine shut-down).

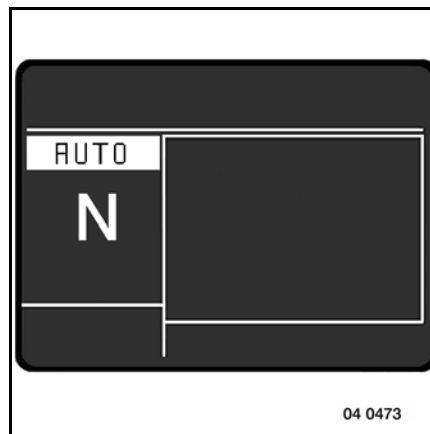

It is possible to start the engine with the gear selector in position "D". However, it is essential to move the gear selector to position "N" then back to position "D" in order to engage a gear. The pictogram (1) invites you to conduct this manoeuvre.

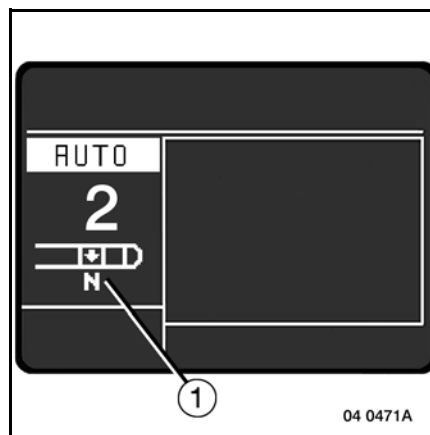

C4-33 Driving



When driving at a speed above 90 km/h, any changing into neutral is forbidden by the gearbox. The gear engaged remains engaged, a buzzer sounds and a pictogram (2) is displayed to invite the driver to move the gear selector to position "D".

For obvious safety reasons, never drive with the gearbox in neutral, with the gear selector in position "N" whatever the road speed.

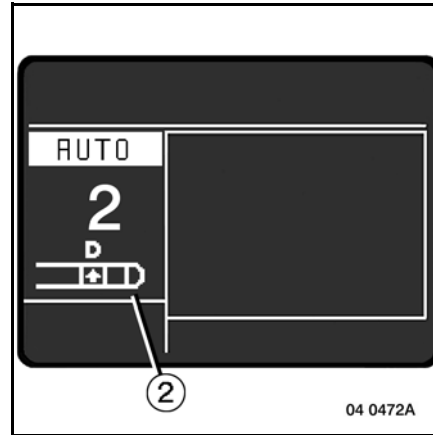

Engine brake

It is not necessary to disable the engine brake when you change gear. The system disables it automatically, then re-activates it after the gear has changed.



The engine brake is activated by the system during certain gear changes to improve the gear change time.

Stopping



With the engine running, before leaving the vehicle:

- Move the ring of the selector to position "N",
- Apply the parking brake.

Opening of the driver's door with the gear selector in position "D" is signalled by a buzzer sounding and a pictogram (1) being displayed inviting the driver to put the gear selector back to position "N".

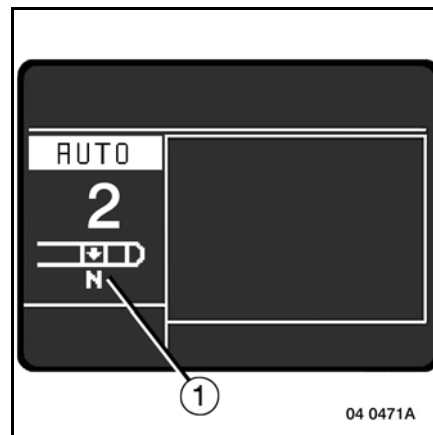

C4-34 Driving

Final stopping of the vehicle

When the vehicle has come to a complete halt, apply the parking brake, move the ring (2) of selector (1) to position "N" and stop the engine with the ignition key.

Protection of the clutch

For the most part in manoeuvring mode, any overheating of the clutch is signalled by the display of a warning pictogram (1) and a message (2) "CLUTCH OVERHEATING".

Excessive use of slipping the clutch is no longer possible:

- Upon acceleration, the clutch is engaged and may cause the engine to stall.
- If you release the accelerator pedal, the clutch is released.



To avoid clutch wear:

- Accelerate freely to move away,
- Move the ring (2) on selector (1) to position "N" if you stop for more than a minute.

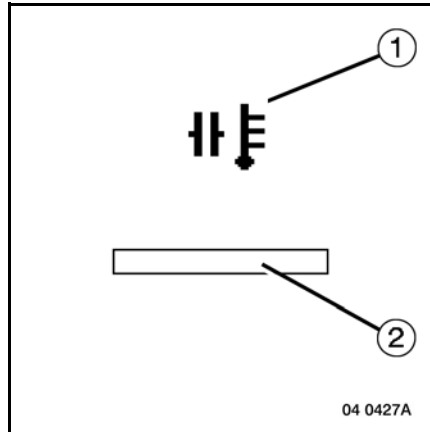

Protection against overspeed

The system prevents gears from being engaged that could lead to engine runaway.

C4-35 Driving

Roller power test bench (2 wheels)

After the vehicle has been put into place on the rollers.

With the vehicle stationary, engine running::

- Move the ring (2) of selector (1) from position "N" to position "D",
- Accelerate fully.

The engine will accelerate to its maximum speed. After a few seconds, the gears will be changed automatically.

The gearbox has changed over to "roller bench" mode".

Information:

- Upshifting: The gears change 2 by 2 at around 1700 rpm.
- Downshifting: upon deceleration, the gears change at around 1100 rpm.

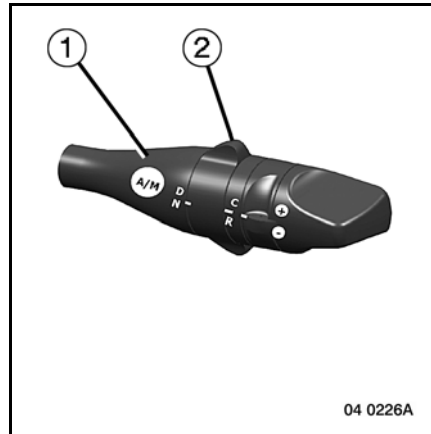

The gear changes are not optimal. The roller bench mode does not allow the application of fuel consumption saving measures.

Quitting the roller bench mode

The system quits the roller bench mode as soon as the front wheel of the vehicle rotate. The normal gear changing mode is re-initialized.

Setting into service at low temperature

Obey the following instructions:

- At temperatures below - 20°C, let the engine run for 10 minutes in order to reach the gearbox operating temperature.

C4-36 Driving

Integral automatic mode

Whenever the engine has been started, when you move the ring (2) of selector (1) from position "N" to position "D", the appropriate moving away gear (4) and the information "Auto" (5) are displayed by default.

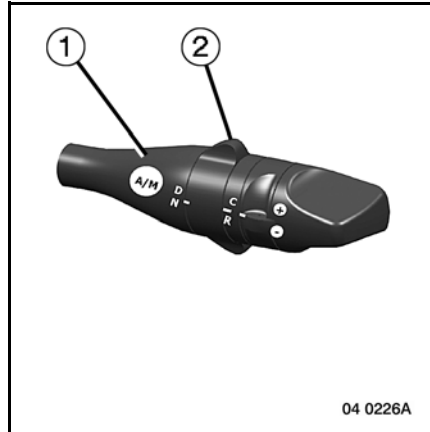

The gearbox shifts through one or several gears automatically, according to the position of the accelerator pedal.



On uphill runs, let gear changing be managed by the system even though the engine speed may seem too low to you.

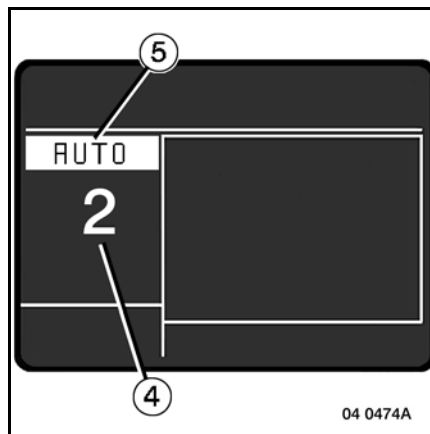

C4-37 Driving

Activation of the "Power" feature

When you wish to overtake and get more power to obtain maximum vehicle mobility, depress the accelerator pedal: the information "Power" (6) is displayed.

Disabling of the "Power" feature

Gently release the accelerator pedal: the information "Power" (6) is erased.



The "Power" feature accentuates fuel consumption.

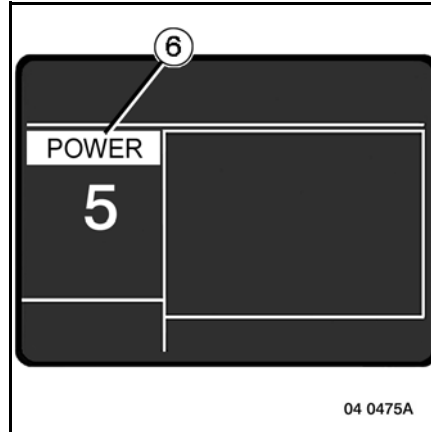

Use on downhill runs

In slowing down phase (brakes or retarder(s) activated), if you are negotiating a steep downhill section with the engine speed high (close to engine overspeed) and with the accelerator pedal fully released, no gear is changed automatically. This serves to hold back the vehicle. In this case, warning pictogram (7) is displayed meaning that the vehicle must be slowed down using the brakes or the retarder(s).

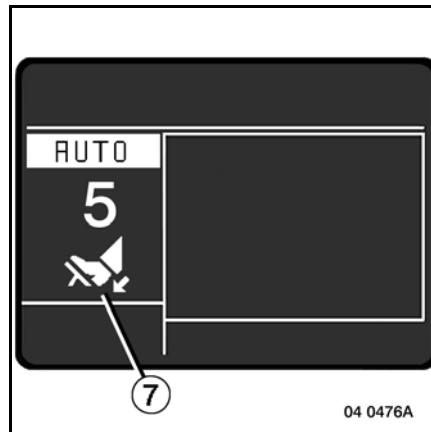

With the retarder(s) inactive and the brakes not applied, if you are negotiating a steep downhill section, the system will automatically change down the gears to protect the engine against overspeed.



If you press hard down on the accelerator pedal, maximum mobility is demanded and the gearbox will change up through several undesired gears.

C4-38 Driving

Full-time manual mode

To change over from automatic mode (information "Auto" (4) displayed) to full-time manual mode (information "Manu" (5) displayed) or vice versa, pull the gear selector briefly in the direction of position "A/M" on the selector (1). This changeover can be made with the vehicle stationary or moving.

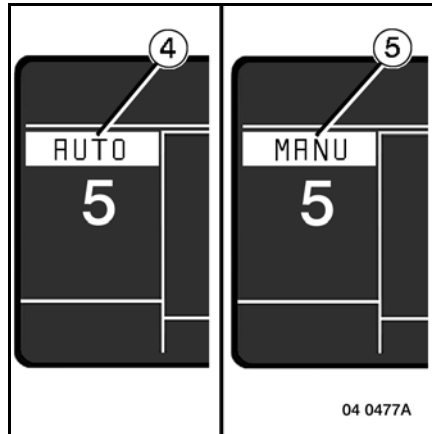

C4-39 Driving

Changing gear

Changing 1 gear:

- To change up 1 gear, move the gear selector (1) forwards in the direction of (+) or rearwards in the direction of (-).

Changing 2 gears:

- To change up 2 gears, move the gear selector (1) forwards in the direction of (+) or rearwards in the direction of (-) while negotiating the hard spot.

Changing 3 gears:

- To change up 3 gears, move the gear selector (1) forwards in the direction of (+) or rearwards in the direction of (-) while negotiating the hard spot and hold the selector in that position for a moment.

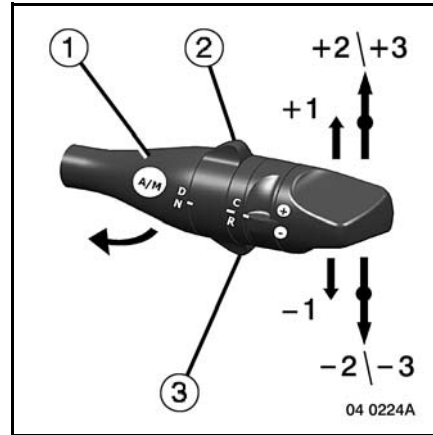

In full-time manual mode, a "driving aid" feature is activated. In addition to the gear engaged (6), the system displays a recommended gear (7).

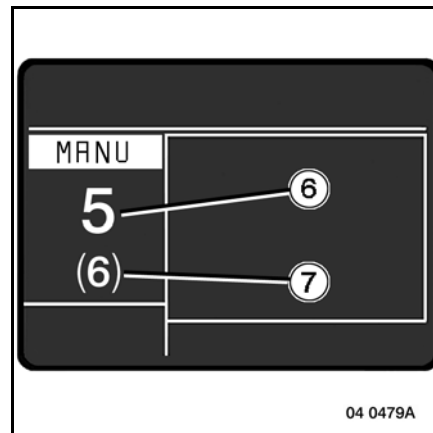

C4-40 Driving

Part-time manual mode

The vehicle is moving, you are in "Auto", information (4) is displayed. If you wish to change the gear engaged by the system, to anticipate a change in the road contour, you can change up or down a gear with the selector (1) by pushing it in the direction of (+) or (-). The information "Manu" (5) flashes: you are in part-time manual mode. To change back to "Auto", you have several courses of action:

- Fully release the accelerator pedal, then depress it again.
- Actuate the "cruise control" feature.
- Push the gear selector (1) in the direction of "A/M".

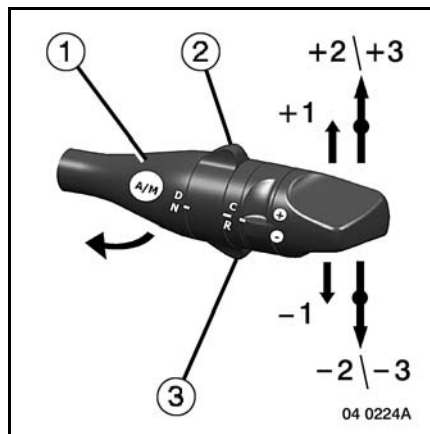
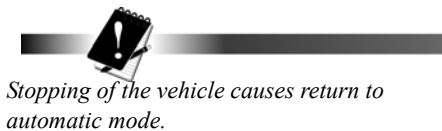
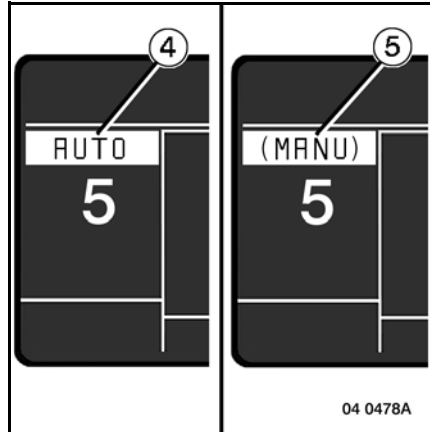

Fall-back mode (lever disconnected)

You can change into neutral by applying the parking brake.

You can engage the moving away gear by releasing the parking brake then depressing the brake pedal.

In both cases, you can make your way to the nearest RENAULT TRUCKS service point or dealer.

C4-41 Driving

Reversing buzzer

Depending on your vehicle's equipment

When you change into reverse gear, a buzzer sounds to warn other road users and passers-by that the vehicle is reversing.

A switch (E2) serves to override the "buzzer" feature.

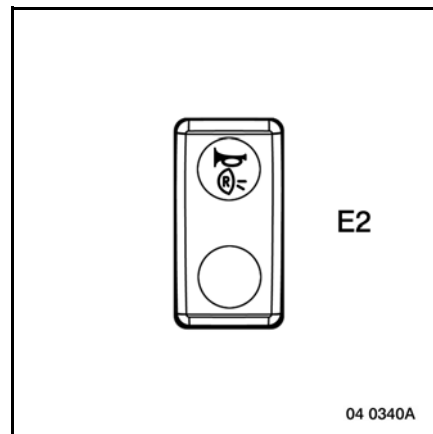

C4-42 Driving

"EBS" braking system

Depending on your vehicle's equipment

The "EBS" system manages vehicle braking and assures anti-lock braking (ABS) and anti-slip regulator (ASR) features.

Anti-lock braking system "ABS"

This system prevents the roadwheels from locking when you apply the brakes sharply.

- Vehicle coupled to a trailer with ABS system: below the threshold, variable from 5 to 15 km/h, depending on the system installed, pictogram (G14) should be illuminated. Above the limit, it should be extinguished.
- Vehicle coupled to a trailer without ABS system: pictogram (G14) remains extinguished.



On some trailers, the pictogram disappears after a few seconds, even when the vehicle is stationary.

In the event of system trouble or malfunction (warning pictogram(s) (G14 - G15) illuminated), its action is overridden and the vehicle reverts to conventional braking. Quickly make your way to a RENAULT TRUCKS service point or dealer to get the system overhauled.



In the event of electronic control mode failure, the EBS system changes over to emergency compressed air mode and a loss of feel may be experienced when you depress the brake pedal. The maximum braking power is still available when you fully depress the brake pedal.

Anti-slip regulator "ASR"

When you move away or during acceleration, this system prevents the roadwheels from slipping, whatever the condition of the road surface.

The system enters into action:

- If a roadwheel spins, it applies the brakes to that wheel to lower its speed to that of the other wheel on the same axle.
- If both roadwheels on the same axle spin, it limits the engine speed, then applies the brakes to the wheel that is still spinning to lower its speed to that of the other wheel.

On the road

During operation of the ASR system, pictogram (G45) is displayed.

On surfaces giving poor wheel grip (snow, ice, gravel...), it is possible to push back the operating threshold of the ASR system by actuating switch (A1). Pictogram (G45) is displayed.

Brakes temperature alert

If the temperature of the brakes is too high, warning pictogram (G17) appears on the information display (L).

It is then necessary to adapt the road speed and your style of driving. Use the retarder(s) if the vehicle is thus equipped.

C4-43 **Driving**

Reduced braking performance alert

If the system detects a significant drop in braking performance of the road combination, warning pictogram (G15) appears on the information display (L). It works together with warning light (I).

Get the condition of the tractor and trailer braking system checked out by a RENAULT TRUCKS service point or dealer (brake-testing bench test).

Defective brakes alert

If the system detects a significant drop in braking performance on one of the tractor road-wheels, warning pictogram (G15) appears on the information display (L). It works together with warning light (I).

Get the condition of the roadwheel braking system concerned checked out by a RENAULT TRUCKS service point or dealer (brake-testing bench test).

ESP anti tip-over alert

If the system detects a risk of vehicle tip-over, it applies the brakes to one or several road-wheels to correct the trajectory. Pictogram (G76) appears on the information display and remains illuminated after the corrective action for a further 5 seconds to inform the driver of a dangerous manoeuvre.

This operation may prove to be dangerous when test driving on tracks with high raised kerbs.

If necessary, get this function disabled by a RENAULT TRUCKS service point or dealer.

C4-44 Driving

Hill-start assist control

This feature serves to simplify uphill moving away manoeuvres by keeping the vehicle brakes applied during the moving away phase.



Use this feature only when moving away uphill.

This feature is not a parking system and should not be used as such.

Vehicle with manual gearbox

- 1- Keep the vehicle stationary by holding it on the brakes.
- 2- Keep the clutch pedal depressed.
- 3- Select a suitable gear for moving away.
- 4- Press switch (A2); the switch warning light comes on.
- 5- Release the brake pedal; the vehicle is held automatically on the brakes. Warning pictogram (G20) appears on the information display (L) for as long as the vehicle is held automatically on the brakes.
- 6- Move away while accelerating and releasing the clutch pedal. The brakes are released automatically when the engine torque is sufficient or when the clutch pedal is fully released.
- 7- Press the switch again to disable the feature; the switch warning light goes out.

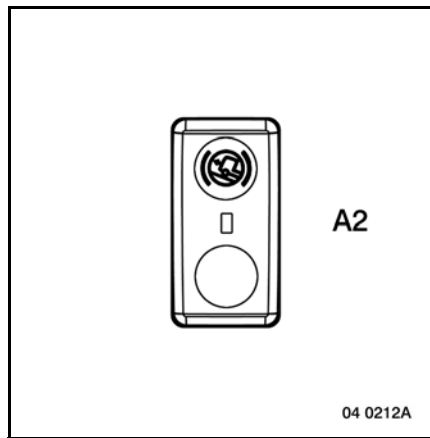

The feature is automatically disabled if the road speed exceeds 30 km/h or if the ignition is switched off with the ignition key.

C4-45 Driving

Vehicle with Optidriver 2 gearbox

- 1- Keep the vehicle stationary by holding it on the brakes.
- 2- Press switch (A2), the switch warning light comes on.
- 3- Release the brake pedal; **the vehicle is held automatically on the brakes for 1 second.** Warning pictogram (G20) appears on the information display (L) and a buzzer sounds for as long as the vehicle is held automatically on the brakes.
- 4- Move away while accelerating. The brakes are released automatically when the engine torque is sufficient or a short instant later when the brake pedal is released.
- 5- Press switch (A2) again to disable the feature; the switch warning light goes out.

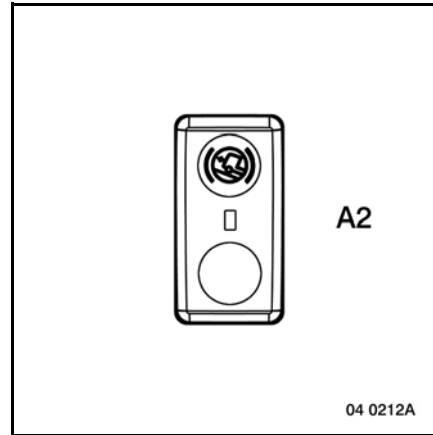

The feature is automatically disabled if the road speed exceeds 30 km/h or if the ignition is switched off with the ignition key.



WHEN THE "HILL-START ASSIST" CONTROL IS ACTIVATED (SWITCH (A2)), THE BRAKES ARE KEPT APPLIED FOR 1 SECOND AFTER THE BRAKE PEDAL IS RELEASED. IF NO ACTION IS TAKEN BEFORE THIS PERIOD ELAPSES (ACCELERATION, BRAKE PEDAL APPLIED AGAIN), THE BRAKES WILL NO LONGER BE KEPT APPLIED AND THE VEHICLE WILL START TO ROLL BACKWARDS.



Once selected with switch (A2), the feature will be active whenever the vehicle stops as long as:

- it is not disabled by pressing switch (A2) again;
- the ignition is not switched off with the ignition key;
- the road speed is below 30 km/h.

C4-46 **Driving**

Emergency braking aid

The system serves to detect an emergency braking situation by measuring the speed of depression of the brake pedal.

In such case, the braking pressures are scaled down in order to obtain more efficient braking. This feature ensures having maximum power available for emergency braking.

When emergency braking is detected, the hazard lights are automatically switched on. To stop them, actuate switch (A3) twice.

Roller bench testing

When the vehicle is to be tested on a roller bench, it is necessary to disable certain monitoring checks made by the EBS system on roadwheel speeds.

Activation of the mode:

- With the information display menu and the remote control .

See pages B-2-37 - B-2-30.

Disabling of the mode:

- By switching off the ignition with the ignition key.
- Automatically, when the front roadwheels speed exceeds 12 km/h.
- With the information display menu and the remote control .

See pages B-2-37 - B-2-30.

C4-47 Driving

"ESP" (electronic stability program) system

Depending on your vehicle's equipment

Warning pictogram (1) (G74) is displayed for 3 seconds when the ignition is switched on to indicate that the vehicle is equipped with the ESP system.

"ESP": trajectory monitoring

This is a stability monitoring system to reduce risks of skidding and tip-over.

If the system detects skidding, the acceleration is reduced and the brakes are automatically applied on all the roadwheels to enable the vehicle to maintain its trajectory.

Active retarders are automatically inhibited in the ESP phase.

Warning pictogram (G77) is illuminated during the ESP phase.

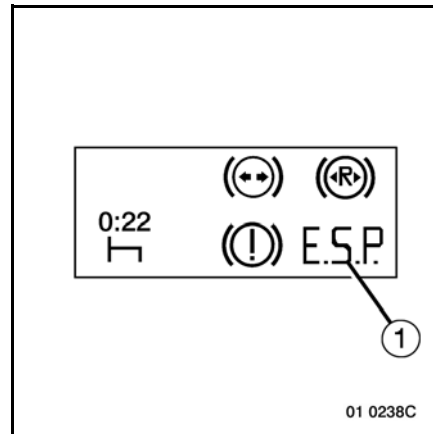

C4-48 Driving

"ESP": anti tip-over

If the system detects a risk of tip-over, the acceleration is reduced. If such reduction is insufficient, the system automatically applies the vehicle brakes to reduce the road speed. The feature is optimized when it is combined with a trailer equipped with ABS or EBS. Warning pictogram (G76) appears on the information display (L) during the ESP phase and disappears 5 seconds after it has finished.



Use the vehicle in the same way as a vehicle without ESP.

ESP reduces risks of tip-over and skidding. However, a vehicle may tip over if the load features a very high centre of gravity, if it hits a kerb at high speed or if the driving style is inappropriate.

The vehicle can also skid on icy roads in spite of it being equipped with ESP.



DO NOT USE A VEHICLE EQUIPPED WITH ESP ON TRACKS WITH VERY HIGH RAISED EDGES (TEST CIRCUIT TYPE).



USING A VEHICLE ON ROADS WITH VERY HIGH RAISED KERBS MAY LEAD THE ESP TO ENTER INTO ACTION WITH DANGEROUS CONSEQUENCES. IF THE VEHICLE HAS TO BE USED ON THIS TYPE OF ROAD, CONSULT A RENAULT TRUCKS SERVICE POINT OR DEALER TO INHIBIT THE ESP FEATURE.



This feature is a supplementary aid for critical driving.

However, it does not push back the limits of the vehicle.

It should not incite the driver to drive faster. It should in no way replace the vigilance or responsibility of the driver during manoeuvres (the driver must always be attentive to sudden events that may arise during driving).

C4-49 Driving

Trailer brake

Depending on your vehicle's equipment

Static trailer brake

Keep switch (F5) pressed to apply the trailer brakes.

The brakes will only be applied if the road speed is below 4 km/h .

The brakes will be release if the road speed exceeds 7 km/h or if the switch is released.

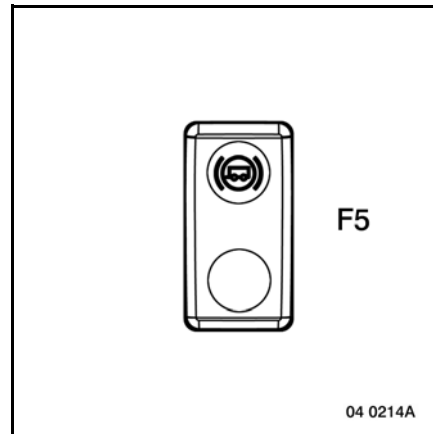

Trailer brake valve

If the tractor is equipped with a lever actuating the trailer brake valve and thus enabling the tractor-trailer unit to be braked by the towed trailer, only use this facility under exceptional circumstances.

Application

Pull the lever.

Release

Release the lever, it automatically returns to its initial position.

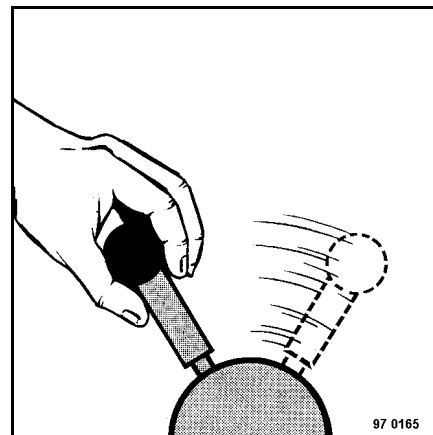

Emergency brake

In the event of failure of the service brakes on an axle, the other axle ensures the efficiency of emergency braking.

C4-50 Driving

Parking brake

Rigid vehicle

Release

Lift up the locking sleeve and move the lever from position (2) to position (1). The warning light goes out.

Application

Lift up the locking sleeve and move the lever from position (1) to position (2). Release the locking sleeve and make sure the lever is locked in position (2). The warning light (S) comes on.

The vehicle is immobilized by the rear axle brakes.

Moving away on hills

To simplify moving away on hills, you can use the parking brake until it reaches the hard spot, without pulling past it. As soon as the lever is released, it automatically returns to position (1).

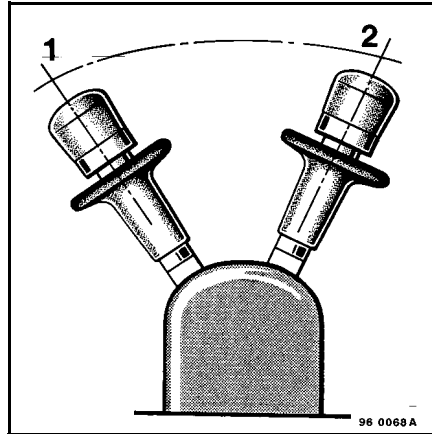

If warning light (S) stays on during release of the parking brake, it may be due to lack of circuit air pressure.

A buzzer sounds and pictogram (G13) is illuminated on the information display to warn the driver that the driver's side door is open or 5 seconds after the ignition has been switched off that the parking brake has not been locked.

Parking brake with safety valve (Scandinavian brakes)

Release

Lift up the locking sleeve and move lever from position (2) to position (1).

Warning pictogram (G25) is displayed, inviting you to depress the brake pedal or the accelerator pedal.

Warning light (S) goes out.

C4-51 Driving

Drawbar rigid and tractor vehicles

This safety valve acts simultaneously on the rear axle of the tractor and on the trailer.

Release

Lift up the locking sleeve and move the lever from position (2) to position (1). The warning light (S) goes out.

Application

Move the lever from position (1) to position (2) (negotiate the hard spot). make sure the lever is locked in position (2). The warning light (S) comes on.

Before leaving the vehicle, move the lever to the "Test" position to ensure efficiency of the parking brake.

Test

Press the lever and move it from position (2) to position (3). This position releases the trailer brake and holds the road rig on the tractor brake. This position serves to ensure that the tractor can alone hold the entire immobilized vehicle.

As soon as the lever is released, it returns automatically to position (2), i.e. to the parking position.

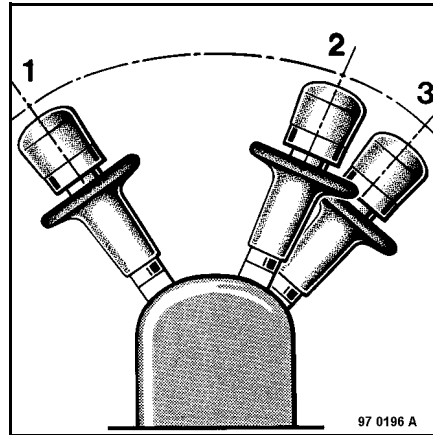

If your road rig has a gross train/combination weight (GTW/GCW) of 60 tonnes, the parking brake also acts on the front axle of the tractor vehicle.

C4-52 Driving

Moving away on hills

To simplify moving away on hills, you can use the parking brake until it reaches the hard spot, without pulling past it. As soon as the lever is released, it automatically returns to position (1).



If warning light (S) stays on during release of the parking brake, it may be due to lack of circuit air pressure.

A buzzer sounds and pictogram (G13) is illuminated on the information display to warn the driver that the driver's side door is open or 5 seconds after the ignition has been switched off that the parking brake has not been locked.

Parking brake with safety valve (Scandinavian brakes)

Release

Lift up the locking sleeve and move lever from position (2) to position (1).

Warning pictogram (G25) is displayed, inviting you to depress the brake pedal or the accelerator pedal.

Warning light (S) goes out.

C5-1 Driving

Stopping

Stopping the engine

Apply the parking brake and move the gear lever into neutral. Always wait for the engine to return to idling speed before actuating the shut-down control.

To stop the engine, switch off the ignition.

Disengage the master switch to cut the current.

Never turn off the master switch while the engine is running to avoid damage to the alternator and the vehicle's electronic components.

If the tachograph printer tray is open when the ignition is switched off, the buzzer sounds and the message (1) "printer tray open" is displayed for around 6 seconds. Close the printer tray before getting out of the vehicle.

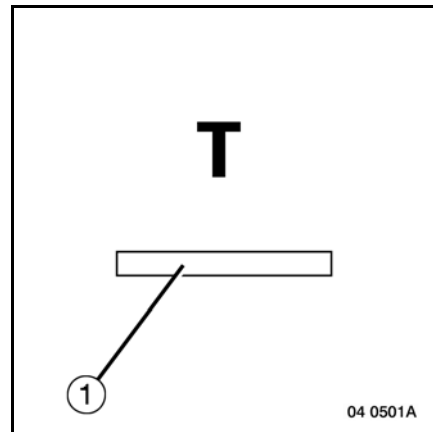

Digital tachograph

If the tachograph printer tray is open when the ignition is switched off, the buzzer sounds and the message (1) "printer tray open" is displayed for around 6 seconds. Close the printer tray.



If the vehicle is to be laid up for a prolonged period of time (more than 10 days), disconnect the circuit by means of the circuit-breaker or remove the fuse (F7) to avoid discharging the batteries through the tachograph.



In the event of fracture of a propeller shaft, if the gearbox is in neutral and the output shaft is moving, take out the fuse (F40) and switch off the ignition to stop the engine.

C5-2 Driving

Engine stop control (cab tilted (1)).

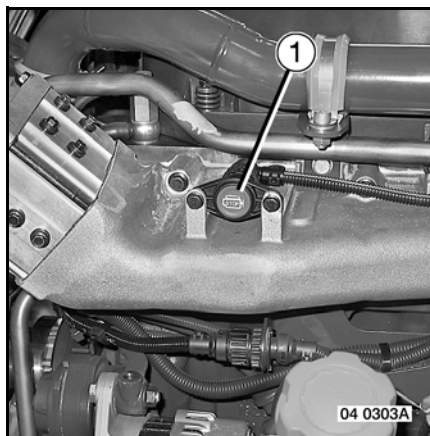

C5-3 Driving

ADR vehicle (transport of dangerous materials)



It is essential to obey engine stopping instructions according to the situation in which you find yourself. Any other procedure may prove to be dangerous.

Switch inside the vehicle

Unlock the switch with the button, then press the bottom of the switch. The "ADR" cut-out cuts off the vehicle's electrical power supply. To reset the cut-out, unlock switch (B4) with button (1), then press the top of the switch.

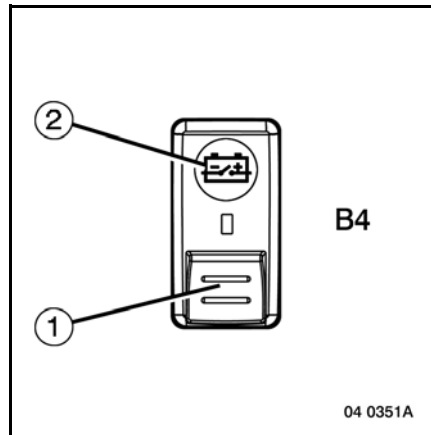

Control outside the vehicle

Lift up guard cover (1), push the control down (2); the engine stops. The "ADR" cut-out cuts off the vehicle's electrical power supply. (see page(s) B1-27).

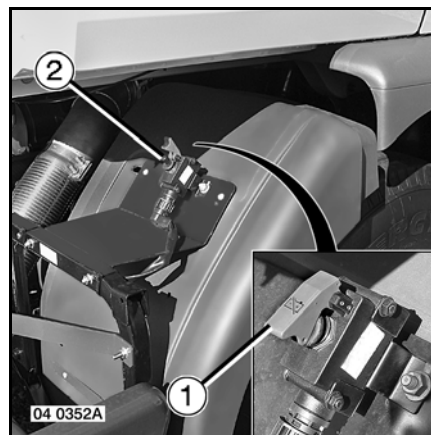

c5-4 Driving

C6-1 Driving

Driving on difficult terrain

"Rear drive axle(s)" diff. lock

Depending on your vehicle's equipment

Do not use:

- On ground giving a firm grip (roads, dry or rocky ground).
- On bends.
- When the vehicle is equipped with an anti-skid device (snow chains, etc...).

Engagement

On ground giving poor grip or when approaching a slippery section of the roadway (while driving, without altering your driving speed), press tab (1) to unlock, then press the top (2) of switch (C5). Pictogram (G44) is displayed.

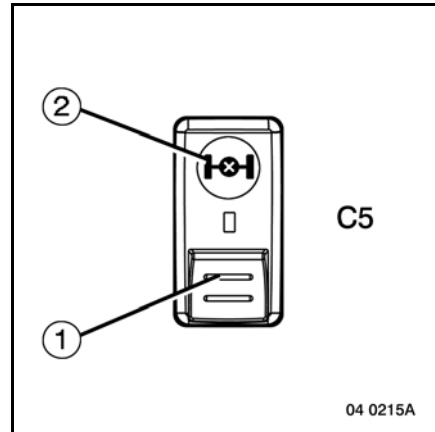

Never engage the diff. lock when one of the drive wheels is slipping. In such case: release the clutch and operate the switch (C5).

Engage the clutch and do not accelerate until the warning pictogram (G44) is displayed.

Disengagement

Press switch (C5). Pictogram (G44) should disappear. If it does not, gently lock the steering over to the right and to the left, while driving very slowly, to enable release of the dog clutch and put out the warning light(s).



The diff. lock disengages automatically when the road speed is above 30 km/h. When the road speed drops below 25 km/h, it re-engages automatically.

C6-2 Driving

Anti-slip regulator (ASR)

This system prevents the roadwheels from slipping when you are moving away or during acceleration, whatever the condition of the road surface.

The system enters into action:

- If a roadwheel spins, it applies the brakes to that wheel to lower its speed to that of the other wheel on the same axle.
- If both roadwheels on the same axle spin, it limits the engine speed, then applies the brakes to the wheel that is still spinning to lower its speed to that of the other wheel.

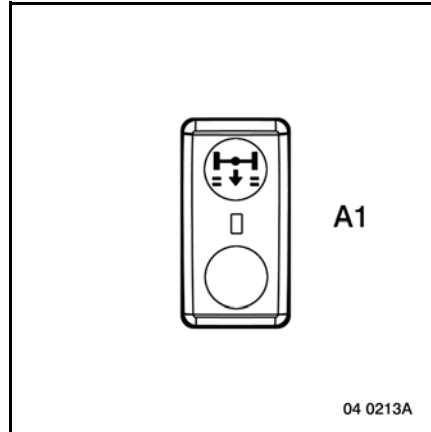

On the road

- During operation of the ASR system, warning pictogram (G45) is displayed.
- On surfaces giving poor wheel grip (snow, ice, gravel...), it is possible to push back the operating threshold of the ASR system by actuating switch (A1). Warning pictogram (G45) flashes.

D1-1 Use of the equipment

Trade equipment

Working spotlight (tractor)

To switch on the working spotlight (1), press switch (B5). Warning pictogram (G50) is displayed.

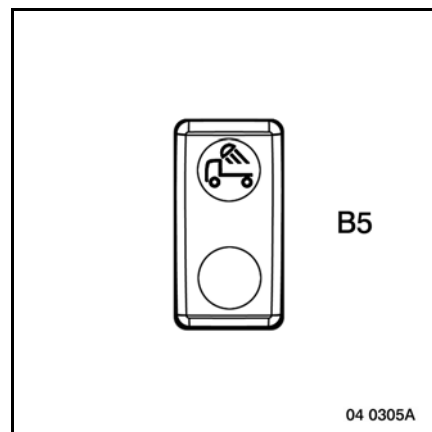
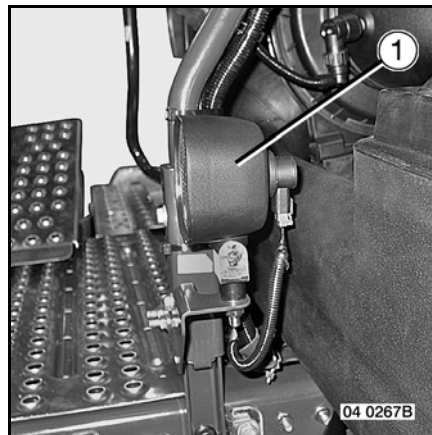

D1-2 Use of the equipment

Fifth wheel coupling



Only fifth wheels mounted by RENAULT TRUCKS are covered in this document. For using fifth wheels mounted as adaptation, refer to the manufacturer's brochure.

These instructions are only a reminder as they form part of the rules of the road haulage profession. Use of the locking handle and safety system: see pages D1-4 - D1-7).

Hitching

Prior to hitching the trailer, check that:

- the fifth wheel locking system is open;
- the support face of the semi-trailer is slightly below the fifth wheel skid plate (about 5 cm). If necessary, adjust the height of the semi-trailer or of the tractor if it is equipped with air suspension;
- the skid plate, the locking system and the kingpin are plentifully greased;
- there is no foreign matter on the friction surfaces;
- the trailer is immobilized by its parking brake or by wheel chocks.

Reverse the tractor slowly into the alignment of the semi-trailer until the skid plate comes into contact with the semi-trailer. Engage the vehicle under the semi-trailer until the fifth wheel locks automatically.

Visually ensure that:

- the fifth wheel is properly locked and in particular that the unlocking prevention system (snap-hook, lock pin, safety lever or catch) is engaged (see pages D1-4 - D1-7).
- the semi-trailer is applied over the full extent of the skid plate.

Carry out a pulling test (with the semi-trailer brake applied, begin to move away gently to ensure that the kingpin is correctly locked in the fifth wheel: the tractor must be held by the trailer).

Connect the yellow brake line, then the red brake line, in sequence.

Connect the hydraulic and electric pipes and lines.

Release the semi-trailer parking brake, according to the assembly.

Raise the landing legs and return the suspension to the "normal" position.

The vehicle is ready to move off.

D1-3 Use of the equipment



If the fifth wheel is provided with an instruction plate, scrupulously follow the directives it contains.

Checks on correct locking (visual and towing test) are vital. They avoid inadvertent unhitching of the semi-trailer and all serious consequences that may entail. If the coupling has not been performed correctly, repeat the hitching operation in full.

Vehicles equipped with double pivots: free the double pivot system when driving on hilly ground.

Unhitching

Immobilize the semi-trailer on flat and stable ground.

Apply the parking brake and scotch the semi-trailer wheels with chocks.

Lower the landing legs and raise the semi-trailer to the coupling level.

Disconnect the red brake line, then the yellow brake line, in sequence.

Disconnect the electric and hydraulic lines and pipes.

Take the strain off the coupling by reversing the tractor very slightly and operate the handle in the direction of "unlocking".

Move the tractor forwards.



Vehicles with air suspension: see page D1-9.

D1-4 Use of the equipment

"GEORG FISCHER" fifth wheel coupling

Unlocking

Press down on lever (1). Pull handle (2) towards yourself to the left. Hook handle (2) on the edge (3) of the skid plate.

Locking

Locking takes place automatically when the lever (2) is returned to its initial position during the hitching phase.

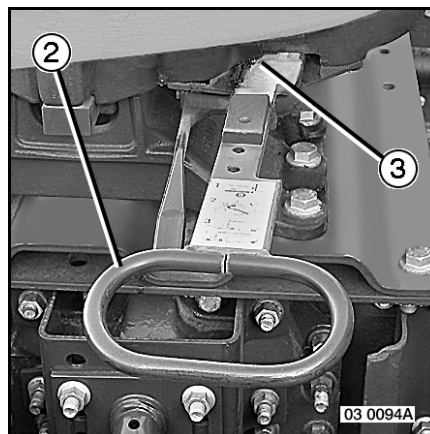
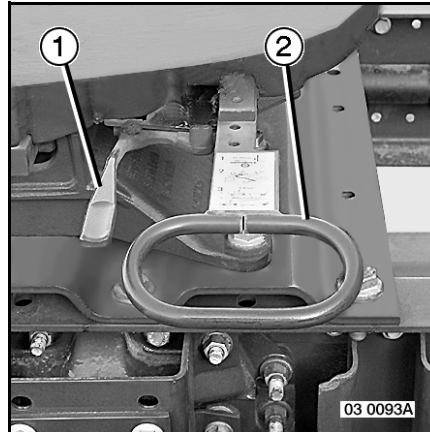

D1-5 Use of the equipment

"JOST" fifth wheel coupling

"JOST" fifth wheel couplings - all models except "JOST 42"

Unlocking

Lift up the bolt (1) by pulling cable (2).
Swing lever (3) forwards and pull it fully outwards. The lever (3) immobilizes in the "unlocking" position.

Locking

Locking takes place automatically when the lever (3) is returned to its initial position during the hitching phase.

Checking locking

Make sure the bolt (1), back in the "locking" position, forbids any forward movement of the lever (3).
The opening (4) can be used to place a safety snap-hook in position.

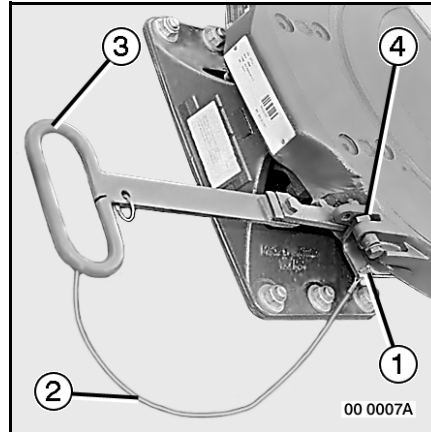

Fifth wheel coupling "JSK 38" is not provided with a cable (2). Lift up the bolt (1) by hand.

D1-6 Use of the equipment

"JOST" 42 fifth wheel coupling

Unlocking

Swing the lever (1) forwards and pull it fully outwards. Hook the lever (1) over the edge of the fifth wheel coupling (2).

Locking

Locking takes place automatically when the lever (1) is returned to its initial position during the hitching phase.

Checking locking

Make sure the lever (1) is sufficiently engaged in the fifth wheel coupling (the red marked catch (3) should no longer be visible).

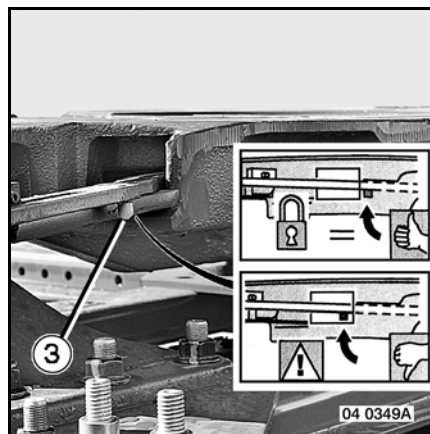
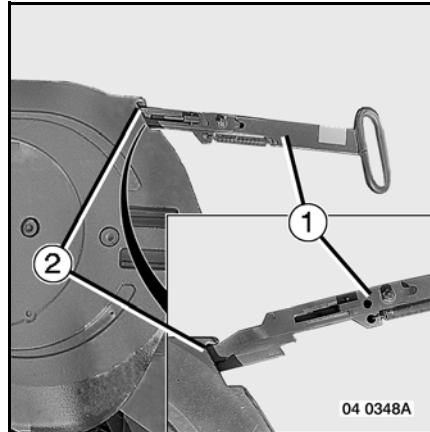

D1-7 Use of the equipment

"FONTAINE" fifth wheel coupling

Unlocking

Pull the handle (1). Swing the lever (2) forwards and pull it fully outwards. The lever (2) immobilizes in the "unlocking" position.

Locking

Locking takes place automatically when the lever (2) is returned to its initial position during the hitching phase.

Checking locking

Make sure the bevelled end (3) of the handle (1) is engaged in its housing. The opening (4) must be fully uncovered. It can be used to place a snap-hook in position.

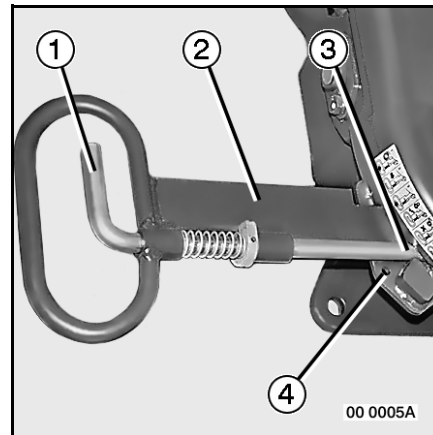

D1-8 Use of the equipment

"FONTAINE" sliding fifth wheel coupling

Unlocking the fifth wheel

Take off the snap hook (1).
Swing the lever (2) forwards and pull it fully outwards. Hook the lever (2) on the edge (3) of the fifth wheel

Locking the fifth wheel

Locking takes place automatically when the lever (2) is returned to its initial position during the hitching phase.

Checking fifth wheel locking

The opening (4) must be fully uncovered. Put the snap hook (1) back into place.

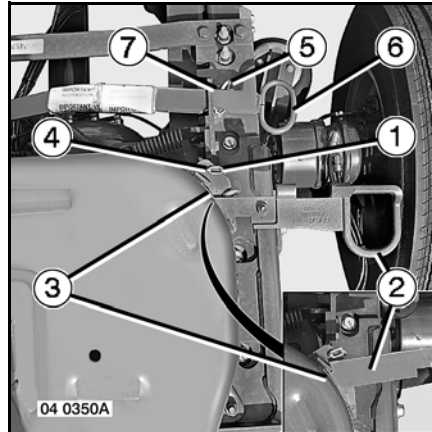

Moving the carriage

Take off the snap hook (5).
Swing the lever (6) forwards, pull it fully outwards and hook it up. Operate the fifth wheel.

Locking the carriage

Release the lever (6) and operate the fifth wheel to allow the locking catches to be properly seated in the bottom of the slots.

Checking carriage locking

Check the positioning of the racks on both sides of the fifth wheel.
The opening (7) must be fully uncovered. Put the snap hook (5) back into place.



Check that there is no interference between the semi-trailer and the tractor, especially during manoeuvring.
Comply with load distribution obligations and the highway code in general.

D1-9 Use of the equipment

Rear suspension

Depending on your vehicle's equipment

Electronic air suspension

This is an air suspension system controlled and monitored by an electronic microprocessor based device. On top of the advantages of a conventional air suspension system, it contributes the following benefits:

- optimization of loading bay services and memorizing of the last level setting (even after a power cut);
- automatic level correction to bring the suspension parallel with the centre-line of the vehicle (even if the load is poorly distributed);
- savings on tyre wear (with lift-up axle option);
- operations piloted by one remote control box (or by dashboard switches for 4x2 vehicles without remote control);
- reduced number of air lines;
- speedy adjustment of level and low air consumption;
- built-in safety systems (alarm, fall-back operating procedures);
- system programming depending on the vehicle and legislation in the country of use;
- above 10 km/h, return of the chassis to the normal level.

Operation

- **Automatic mode**
The system keeps the suspension at a normal level, defined by programming.
- **Manual mode**
Manual mode is programmed, but operation in manual mode is only possible at speeds below 10 km/h.
The manual mode allows the height of the chassis to be adjusted to the required level. To return to automatic mode, press the button on the remote control (normal level) (or press the dashboard switch on 4x2 vehicles without remote control) or when the road speed is above 10 km/h.
- **Information pictogram (G47)**
This pictogram is illuminated when the vehicle level is different from the normal level.
- **Alert pictogram (G29)**
This pictogram is displayed as soon as a fault is identified. The electronic box safety device automatically neutralizes the control system, partly or in full..

On the road

Pictogram (G29) is displayed when a suspension malfunction has been detected.

When stationary

Pictogram (G29) is displayed when a suspension malfunction has been detected. Run a test (see page D1-19).

When taking the road

When the vehicle moves off, the suspension height is only taken into consideration when the parking brake is released .

D1-10 Use of the equipment

Remote control box

Depending on your vehicle's equipment

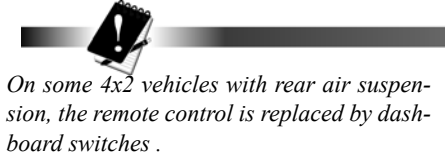

For each suspension model, there is a corresponding type of control box.

Location of remote control box (1) in cab.

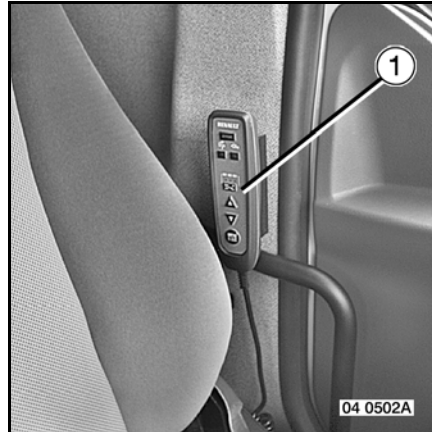

Hitching/unhitching a semi-trailer on a vehicle equipped with air suspension

To unhitch the semi-trailer:

- Raise the suspension to the "up" position.
- Lower the trailer landing legs.
- Unlock the fifth wheel coupling.
- Move the vehicle forwards slightly to disengage the kingpin.
- Lower the vehicle slightly to dislodge the fifth wheel coupling.
- Disengage the tractor, then lower the suspension to the 'road' position before moving away.

To hitch the semi-trailer:

- Adjust the height of the fifth wheel coupling before engaging the vehicle.
- Perform a pulling test (see page D1-2).
- When hitching is finished, move the suspension to the 'up' position.
- Raise the trailer landing legs.
- Return the suspension to the 'road' position before moving away.

D1-11 Use of the equipment

4x2 vehicle with adjustable rear suspension

Depending on your vehicle's equipment

Without remote control

Switches (C1 - C2 - C3), located on the dashboard, serve to raise and lower the rear suspension and return to the road level.

The ECS system only takes account of commands transmitted by the switches if the air pressure is above 8 bars and the road speed is below 10 km/h.

Controls available:

- C1 : "raise / lower" control,
- C2 : "memorize / recall memorized setting" control,
- C3 : "return to road level / standby" control.

Use

Engage the master switch.

Switch on the ignition (if the air pressure is too low, start the engine).

"Raise" feature"

To raise the suspension, move toggle switch (C1) to position (1). When the suspension reaches its bottom abutment height, the system no longer takes account of the switch being moved to position (1).

"Lower" feature"

To lower the suspension, move toggle switch (C1) to position (2). When the suspension reaches its bottom abutment height, the system no longer takes account of the switch being moved to position (2).

Memorizing a level

To memorize a level, the suspension must have previously been set to that level by means of toggle switch (C1).

Once the required height is reached, press toggle switch (C2) for at least 5 seconds, then release it.

The required height is memorized.

To recall this height, just press toggle switch (C2) for at least 2 seconds, but no longer than 5 seconds.

Return to road level

To recall the road level, move toggle switch (C3) to position (1).

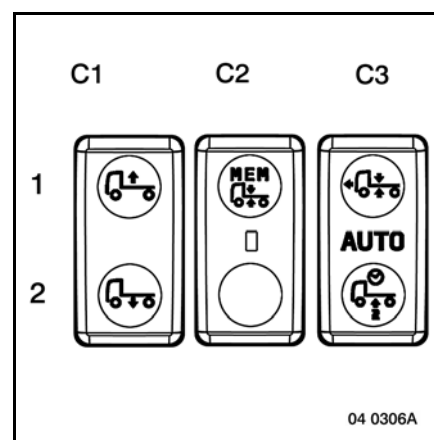

D1-12 Use of the equipment



IN THE EVENT OF DANGER, IT IS POSSIBLE TO STOP THE MOVEMENT STRAIGHT AWAY BY PRESSING SWITCH (C1) ONCE.



If the speed of movement is considered too fast by the electronic system, it limits that speed by cutting the air flow.

Standby

Keep toggle switch (C3) depressed in position (2) and switch off the ignition.

The suspension will remain in a stabilized position for 1 hour. It is also possible to modify the suspension height with the raise / lower switch (C1).



IF YOUR VEHICLE HAS A GROSS TRAIN/COMBINATION WEIGHT (GTW/GCW) OF 60 TONNES, THE PARKING BRAKE ACTS ON THE FRONT AXLE IN ADDITION TO THE DRIVE AXLE.

DURING SUSPENSION ADJUSTMENT OPERATIONS, THE FRONT AXLE BRAKE IS RELEASED SO AS TO NOT GENERATE ANY MECHANICAL STRESS.

BEFORE ADJUSTING THE SUSPENSION, MAKE SURE THERE IS NO RISK OF THE VEHICLE MOVING.

D1-13 Use of the equipment

4x2 - 6x2 vehicle with adjustable rear suspension

Depending on your vehicle's equipment

With remote control

The remote control serves to raise and lower the rear suspension and return to the "road" position.

It is connected to the ECS electronic box, which provides power supply to the internal electronics system.

The ECS system does not take account of controls transmitted by the remote control if the air pressure is more than 8 bars and if the road speed is less than 10 km/h.

D1-14 Use of the equipment

Controls available:

- "STOP" control (1).
- "Standby" control (2).
- "Return to road position" control (3).
- "Up" control (4).
- "Down" control (5).
- "Memorize" control (6).

Using the remote control box

Engage the master switch.

Switch on the ignition (if the air pressure is too low, start the engine).

To activate a feature

Press the button corresponding to the manoeuvre required.

"Raise" feature

To raise the suspension, press control button (4). When the suspension reaches its top abutment height, the system no longer takes account of control button (4).

"Lower" feature

To lower the suspension, press control button (5). When the suspension reaches its bottom abutment height, the system no longer takes account of control button (5).

Memorizing a level

To memorize a level, the suspension must have previously been set to that level by means of control buttons (4) and (5).

Once the required height is reached, press control button (6) for at least 5 seconds, then release it.

The required height is memorized.

To recall this height, just press control button (6) for at least 2 seconds, but no longer than 5 seconds.

Return to road level

To recall the road level, press control button (3).

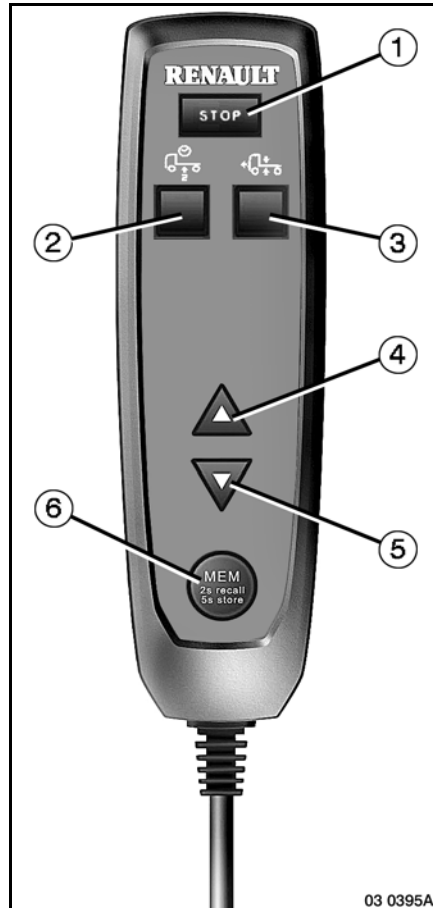

D1-15 Use of the equipment



IN THE EVENT OF DANGER, IT IS POSSIBLE TO STOP THE MOVEMENT STRAIGHT AWAY BY PRESSING BUTTON (1) ONCE.



If the speed of movement is considered too fast by the electronic system, it limits that speed by cutting the air flow.

Standby

Keep toggle switch (2) depressed and switch off the ignition.

The suspension will remain in a stabilized position for 1 hour. It is also possible to modify the suspension height with the raise / lower switch (4) - (5).



IF YOUR VEHICLE HAS A GROSS TRAIN/COMBINATION WEIGHT (GTW/GCW) OF 60 TONNES, THE PARKING BRAKE ACTS ON THE FRONT AXLE IN ADDITION TO THE DRIVE AXLE.

DURING SUSPENSION ADJUSTMENT OPERATIONS, THE FRONT AXLE BRAKE IS RELEASED SO AS TO NOT GENERATE ANY MECHANICAL STRESS.

BEFORE ADJUSTING THE SUSPENSION, MAKE SURE THERE IS NO RISK OF THE VEHICLE MOVING.

D1-16 Use of the equipment

6x2 vehicle with adjustable rear suspension + lift-up axle

Keep toggle switch (C3) depressed: the axle will be raised if the load on it permits.

Warning pictogram (P) appears on the information display.

Press the top of switch (C3): the axle will be lowered.

A first dab on switch (C4) serves to optimize vehicle traction. Warning pictogram (G48) appears on information display (L).

The load on the live axle is at the maximum of its legal capacity.

A second dab on switch (C4) serves to apply maximum load on the rear axle in order to get out of a difficult situation provided that the vehicle speed is less than 30 km/h. Warning pictogram (G48) appears on the information display.

A third dab on switch (C4) returns the system to automatic load balancing mode.

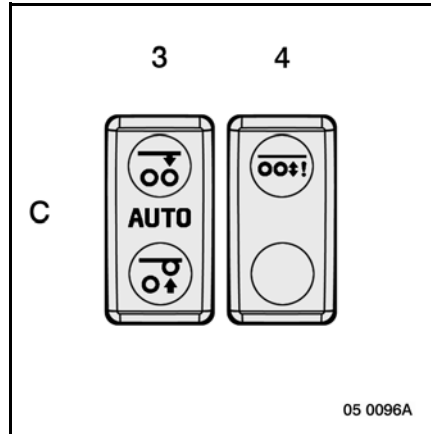

D1-17 Use of the equipment

4x2 - 6x2 vehicle with integral suspension

The remote control serves to raise and lower the front and/or rear suspension and return to the 'road' position.

It is connected to the ECS electronic box, which provides power supply to the internal electronics system.

The ECS system does not take account of controls transmitted by the remote control if the air pressure is more than 8 bars and if the road speed is less than 10 km/h.

Controls available:

- "STOP" control (1).
- "Standby" control (2).
- "Return to road position" control (3).
- Selection control: "drive axle and axle(s)" / "memorized heights" (4).
- "Up" control (5).
- "Down" control (6).
- "Memorize" / "Recall memorized setting" control (7).

Use of the remote control box

Engage the master switch.

Switch on the ignition (if there is insufficient air pressure, start the engine).

Adjusting the suspension height

Using control (4), select:

- front suspension.
- rear suspension.
- front and rear suspensions.



Without taking action on the selection control (4), any action on the "raise" (5) and "lower" (6) controls simultaneously affects the front and rear suspensions.

"Raise" function

To raise the suspension, press button (5). When the suspension has reached top abutment, the system no longer takes the button (5) into account.

"Lower" function

To lower the suspension, press button (6). When the suspension has reached bottom abutment, the system no longer takes the button (6) into account.

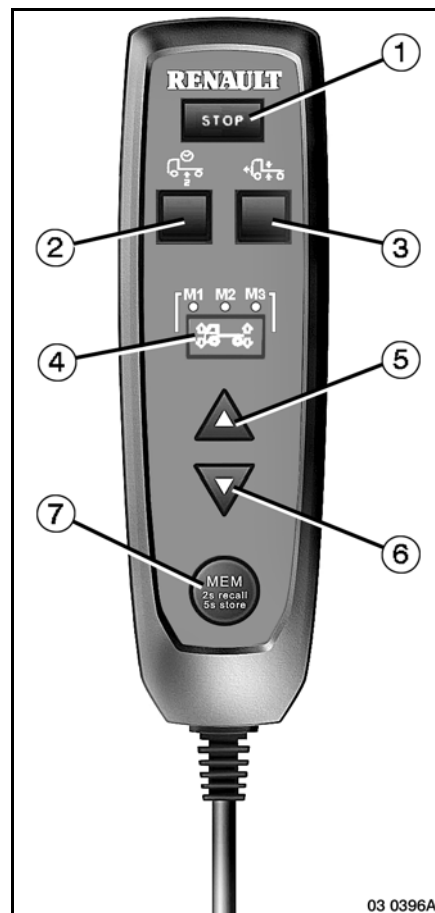

D1-18 Use of the equipment

Memorizing a level

To memorize a level, it must have been previously set using buttons (5) and (6).

Once the required height is reached, select the required memorized setting with button (4), press button (7) for at least 5 seconds, then release.

The required height is memorized.

To recall this height, just select the corresponding memorized setting with button (4) then press button (7) for at least 2 seconds, but for less than 5 seconds.

Return to road position

To recall the road position, press button (3).



IN CASE OF DANGER, IT IS POSSIBLE TO IMMEDIATELY STOP A MOVEMENT BY GIVING A DAB ON BUTTON (1).



If the speed of movement is considered too fast by the electronic system, it limits that speed by cutting the air flow.

Standby

Keep toggle switch (2) depressed and switch off the ignition.

The suspension will remain in a stabilized position for 1 hour. It is also possible to modify the suspension height with the raise / lower switch (5) - (6).

D1-19 Use of the equipment

6x2 vehicle with adjustable front and rear suspensions + lift-up axle

Keep toggle switch (C3) depressed: the axle will be raised if the load on it permits.

Warning pictogram (P) appears on the information display.

Press the top of switch (C3): the axle will be lowered.

A first dab on switch (C4) serves to optimize vehicle traction. Warning pictogram (G48) appears on information display (L).

The load on the live axle is at the maximum of its legal capacity.

A second dab on switch (C4) serves to apply maximum load on the rear axle in order to get out of a difficult situation provided that the vehicle speed is less than 30 km/h. Warning pictogram (G48) appears on the information display (L).

A third dab on switch (C4) returns the system to automatic load balancing mode.

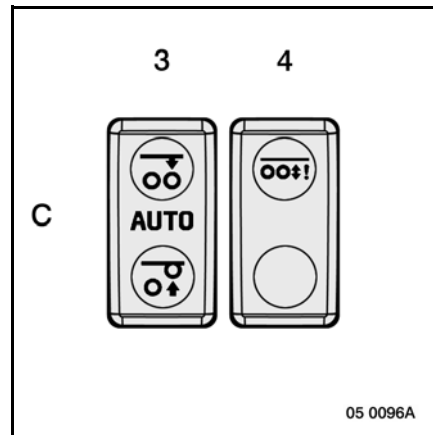

Test procedure

Disengage then re-engage the master switch (10 seconds interruption).

If alert pictogram (G29) is displayed again, consult the nearest RENAULT TRUCKS service point or dealer.

Drive at low speed (20 km/h max.) and take extra care to maintain ample stopping distances.

If alert pictogram (G29) disappears, the minor fault has been cleared. Nevertheless, consult the nearest RENAULT TRUCKS service point or dealer.

Fault finding and maintenance is to be carried out using the RENAULT TRUCKS test tool plugged into diagnostic socket (3).

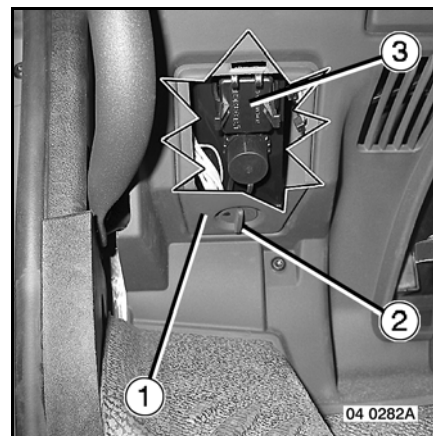

Any work carried out on sensors, linkage or controls, or replacement of the electronic control unit, requires the system parameters to be re-programmed and the system to be re-calibrated. These operations must be carried out by a RENAULT TRUCKS service point or dealer.

D1-20 Use of the equipment

Power take-off

Depending on your vehicle's equipment

Power take-offs mounted on gearbox ZF

With the vehicle stationary, engine idling, gearbox in neutral, parking brake and/or service brake applied, release the clutch.

Depending on the PTO chosen, press one of the control switches (A5 / B1 / B2) and keep it depressed: pictogram (G1) and "PTO engagement" are displayed.

Once pictogram (G41) is displayed, release switch (A5 / B1 / B2) and the clutch pedal.

The power take-off rotates as from that moment.

Warning pictogram (G1) and "PTO forbidden" are displayed if any one condition is not fulfilled.

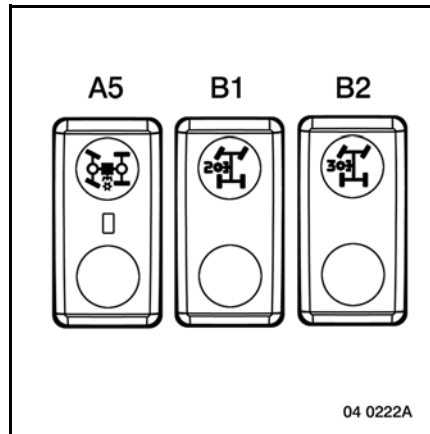

Disengagement

To disengage the PTO, it is necessary to release the clutch and press the corresponding control switch (A5 / B1 / B2).

The PTO disengages automatically if the gear lever changes state, if the ignition is switched off or if the engine stalls.

Engine rotating speed

If a hydraulic pump is being driven, do not exceed the engine speed indicated by the equipment manufacturer.

The minimum engine speed is limited to 600 rpm, the maximum engine speed to 1500 rpm and the rated engine speed to 1000 rpm ex works.

Depending on the equipment built by the equipment manufacturer, the engine speed and certain engagement conditions can be modified using the RENAULT TRUCKS bodybuilder test tool.

D1-21 Use of the equipment

Power take-off

Depending on your vehicle's equipment

Power take-offs mounted on gearbox Optidriver 2

Two possible uses (when stationary or while moving)

Use while stationary

- Engine speed < 700 rpm.
- Ring (2) on selector (1) in position "N" (gearbox in neutral).
- Parking brake and/or service brake applied.
- Zero road speed.

Press PTO control switch (A5) until pictogram (G41) is displayed.

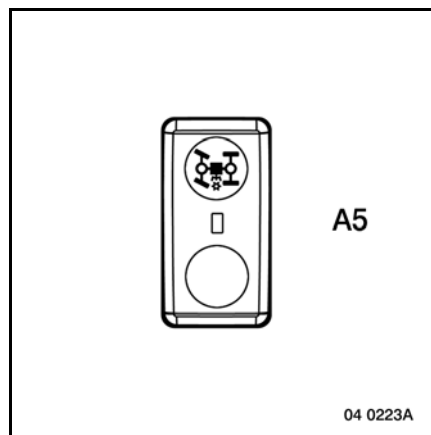
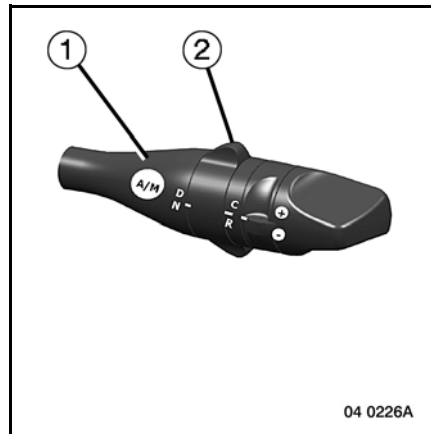

D1-22 Use of the equipment

Once the PTO is engaged, adjust the engine speed:

- Move toggle switch (A6) to the "ON" position.
- Adjust the engine speed with toggle switch (A7).

The symbol "N" and pictograms (G42 - G43) are displayed.

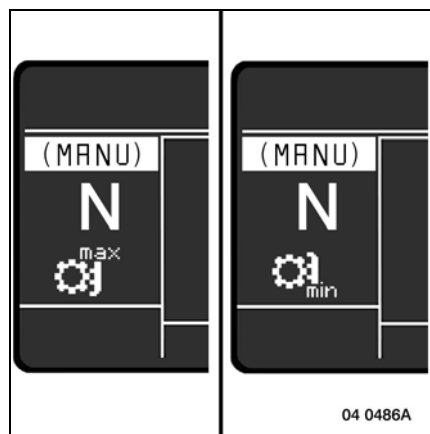
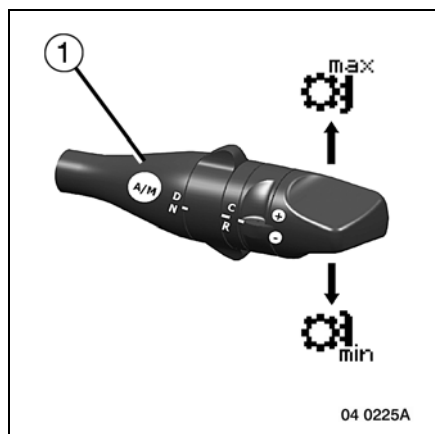
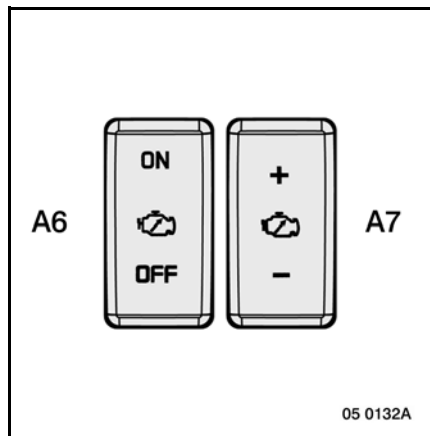

Two operating speeds for the power take-off

When the vehicle is stationary, select the "min." or "max." speed by moving the selector (1):

- forwards, parallel with the steering wheel, to the (+) "max." speed position.
- rearwards, parallel with the steering wheel, to the (-) "min." speed position.

D1-23 Use of the equipment

Use when the vehicle is moving



Feature to be enabled by dealer or by bodybuilder using the RENAULT TRUCKS bodybuilder test tool

The power take-off is engaged while the vehicle is stationary.

- Engine speed < 700 rpm.
- Parking brake and/or service brake applied.
- Zero road speed.
- Ring (2) on selector (1) in position "N".
- Press PTO control switch (A5). Pictogram (G41) and "PTO engagement" are displayed.



To facilitate engagement of the PTO, release the service brake and gently depress the accelerator pedal.

- The PTO is engaged, pictograms (G41 - G42) or (G41 - G43) appear on the information display.
- Release PTO control switch (A5).
- With the vehicle stationary, select the moving away gear suitable for such use (only the first 6 gears are possible).



- *The rotating speed of the PTO depends on the gear engaged:
1st, 3rd or 5th gear: PTO minimum speed.
2nd, 4th or 6th gear: PTO maximum speed.*
- Depress the accelerator pedal to move the vehicle away: the PTO begins to rotate.



Gear changing is no longer possible.



When using the PTO while the vehicle is moving, the cruise control / engine speed regulator will be inoperative for safety reasons. The engine speed is to be modified by using the accelerator pedal.

D1-24 Use of the equipment

Disengagement of the PTO

The PTO is disengaged:

- by pressing switch (A5),
- if the selector is moved back to the neutral position (ring (2) in position "N"),
- if the engine stalls.



Certain PTO engagement / disengagement and engine speed regulation conditions can be adjusted using the RENAULT TRUCKS bodybuilders software.

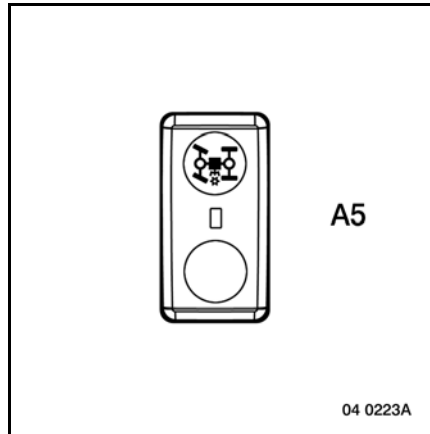

PTO rotating speed

For an engine speed of 1000 rpm.

Front splitter in low speed range (PTO minimum speed): gearbox neutral, 1st, 3rd or 5th gear.

- Hydrocar 81: 705 rpm.
- Hydrocar 84: 910 rpm.

Front splitter in high speed range (PTO maximum speed): gearbox neutral, 2nd, 4th or 6th gear.

- Hydrocar 81: 897 rpm.
- Hydrocar 84: 1159 rpm.

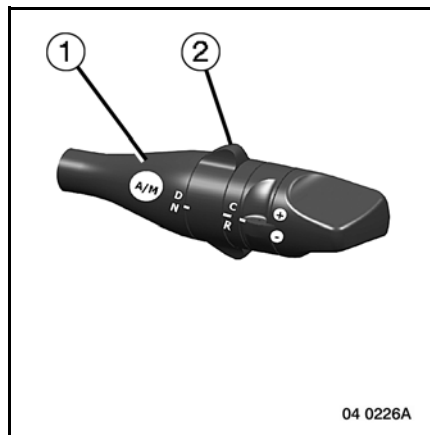

D1-25 Use of the equipment

Roof deflector



Vehicle equipped with refrigerator unit:

If the vehicle is equipped with a roof deflector, ensure that the deflector does not interfere with correct operation of the refrigerator unit (limited cooling of the condenser).

D1-26 Use of the equipment

D2-1 Use of the equipment

Monitoring / management equipment

Diagnostic socket

To gain access to diagnostic socket (3) (2) through 1/4 of a turn (3), to open cover (1).

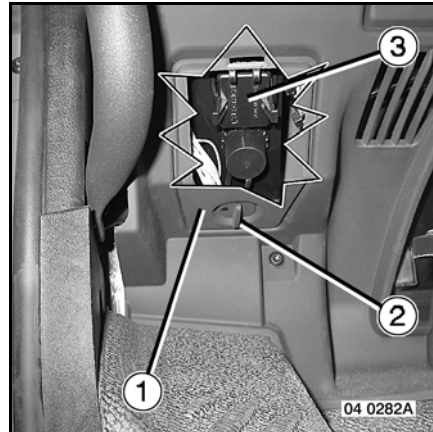

Infomax

Depending on your vehicle's equipment

To gain access to the "SAE" socket (3) to plug in Infomax, open cover (1) by turning the catches (2) through 1/4 of a turn.

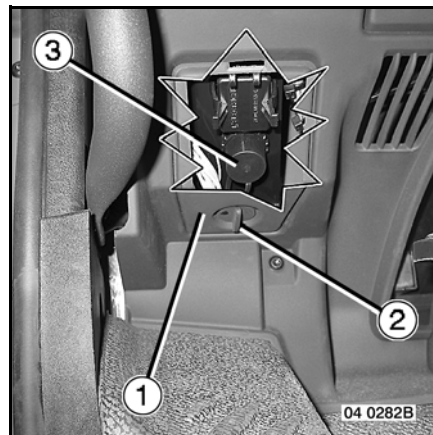

D2-2 Use of the equipment

E1-1 Features - servicing

Identification

Vehicle identification

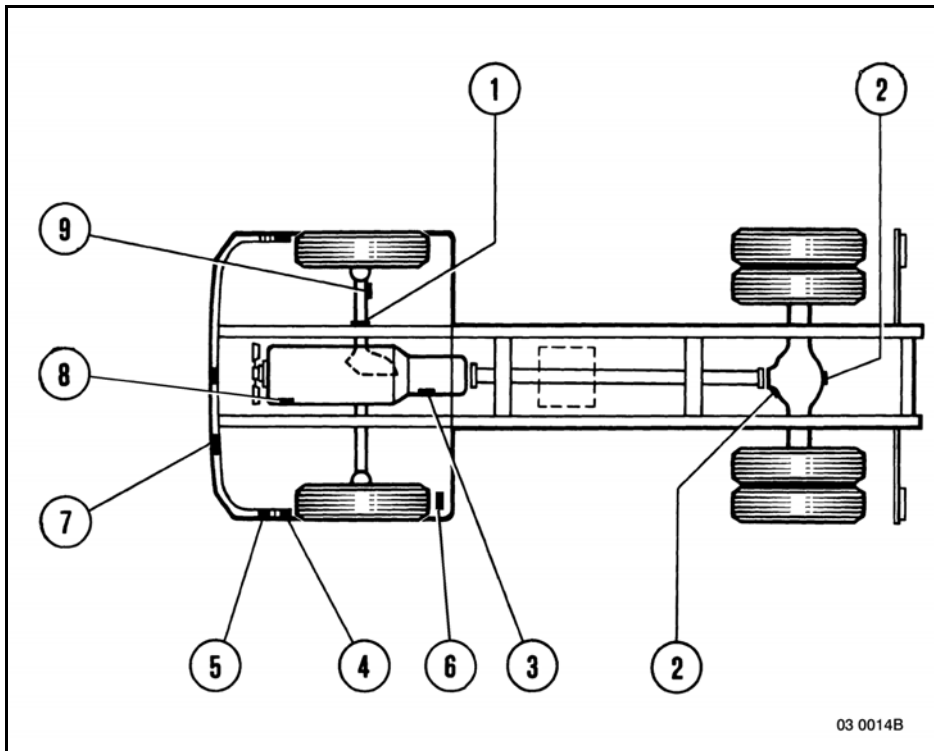

E1-2 Features - servicing

Depending on your vehicle's equipment

- 1- Chassis
- 2- Drive axle
- 3- Gearbox
- 4- Manufacturer's plate
Pollution index
Headlamps wash label
- 5- Conformity plate
ADR plate
- 6- Tachograph plate
- 7- Paint reference N°
CAM plate N°
- 8- Engine
- 9- Axle

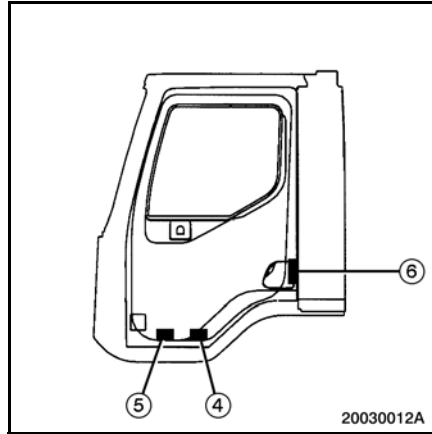

E2-1 Features - servicing

Daily checks

Clutch fluid level

Hydraulic system

- Check the fluid level in reservoir (1). The fluid level should be between the "MIN." and "MAX." marks. Top up, if necessary.



Exclusively use the recommended clutch fluid.

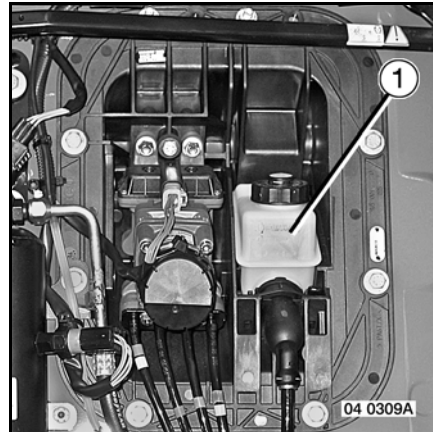

Coolant level

Check the coolant level through the transparent wall of the expansion chamber. The coolant level should be flush with the filler port. Top up, if necessary.



IF FOR SOME VITAL REASON THE COOLANT HAS TO BE TOPPED UP WHILE THE ENGINE IS HOT, FIRST OF ALL CAREFULLY RELEASE THE PRESSURE-VACUUM CAP (1) BY 1/4 OF A TURN TO DECOMPRESS THE SYSTEM. RETIGHTEN THE CAP IMMEDIATELY. THEN REMOVE THE FILLER CAP (2) AND TOP UP THE COOLANT.

USE ONLY THE COOLANT RECOMMENDED BY RENAULT TRUCKS.

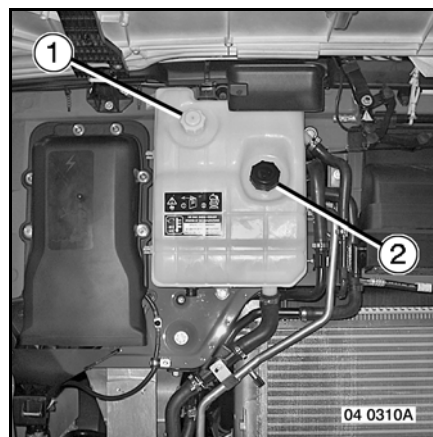

E2-2 Features - servicing

Checking the oil level

Tilt the cab.

Check the oil level with dipstick (1).



Always check the oil level on flat ground 2 hours after the engine has been shut-down.

Top up with oil to level, if necessary.

Filler cap (2).

Oil dipstick reading:

- 1- Maximum level
- 2- Minimum level

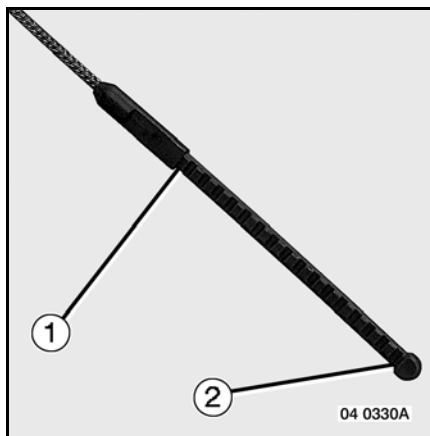
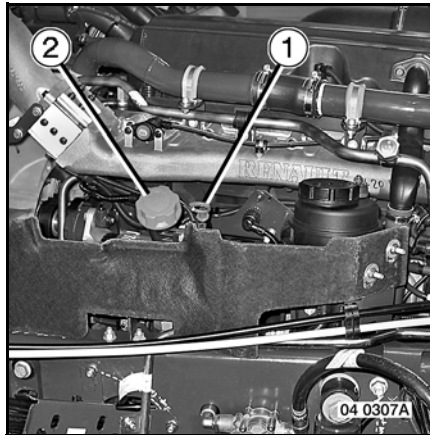

It is always possible for you to top up the engine oil without having to check the dipstick, by following the instructions on the information display.

Filler plug.

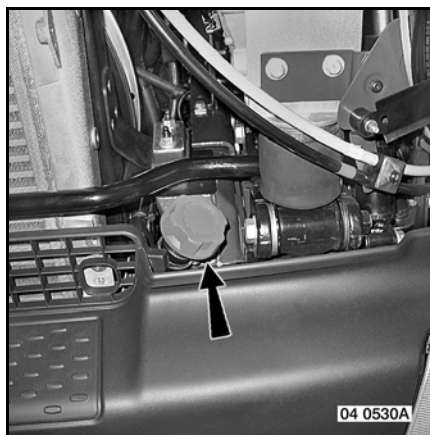

E2-3 Features - servicing

Steering oil level

Tilt the cab.

(See page B1-20).

Check the steering oil level (2).

Top up with oil to level through filler cap (1), if necessary.

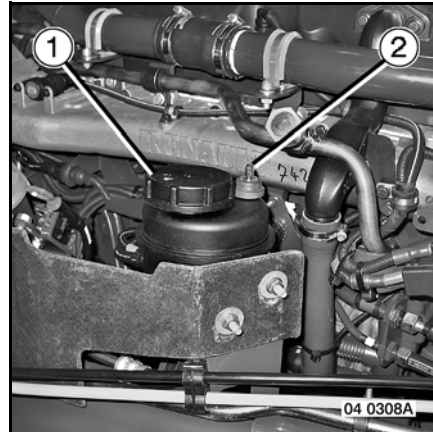

Air tanks

Actuate bleed valves (1) to get rid of all water from the air tanks.

Carry out this operation:

- Every day (in winter).
- Every week (outside winter).

If not drain the air tanks.

Get the APM checked out by a RENAULT TRUCKS service point or dealer and replace the cartridge (see page E26-1).

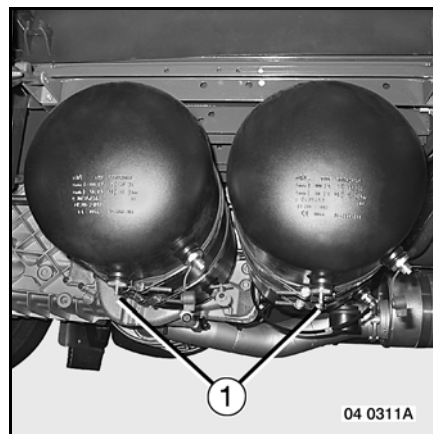

AS SAFETY PRECAUTION, MOVE THE GEAR LEVER TO NEUTRAL BEFORE DRAINING THE AIR TANKS.

E2-4 Features - servicing

Tyres

Tyre pressures (see page E20-3).

Windscreen wash reservoir level

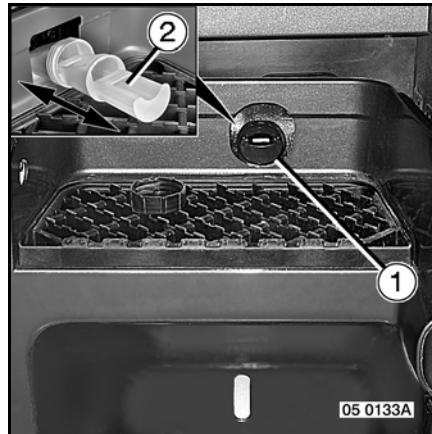

Windscreen wash reservoir capacity

Litres

9

Regularly check the level in reservoir (1). Top up, if necessary. To avoid scale deposits and pipe obstruction, it is advised to add a screen wash additive (RENAULT TRUCKS product). This product also serves as anti-freeze. It can be left in all the year round, if necessary. To top up the level, unfold filler spout (2).

E2-5 Features - servicing

Headlamps wash reservoir

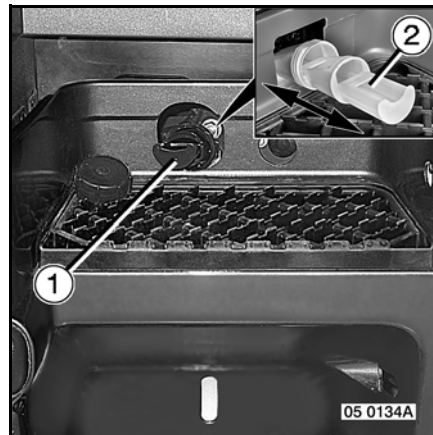

Headlamps wash reservoir capacity

Litres

9

Regularly check the level in reservoir (1). Top up, if necessary. To avoid scale deposits and pipe obstruction, it is advised to add a screen wash additive (RENAULT TRUCKS product). This product also serves as anti-freeze. It can be left in all the year round, if necessary. To top up the level, unfold filler spout (2).

E2-6 Features - servicing

E3-1 Features - servicing

Routine servicing

Bulbs

If a bulb has to be changed, always replace it with a bulb of the same wattage and type.

Depending on your vehicle's equipment

Table of bulbs

Assignment	Wattage
Front side/parking lights	5W
Lateral side/parking lights	3W
Rear side/parking lights	2x5W
Front flashing lights	21W
Side flashing lights	21W
Rear flashing lights	21W
Quartz-iodine dipped beam headlights	70W
Xenon dipped beam headlights	35W
Main beam headlights	70W
Fog driving lights	70W
Marker lights	5W
Registration plate light	10W
Stop lights	21W
Fog light(s)	21W
Reversing lights	21W
Stepwell lights	5W
Cab overhead light	10W
Bunk overhead light	10W
Map reader	10W
Working spotlights (tractor)	21W
Working spotlights (tractor)	70W

E3-2 Features - servicing

Changing bulbs

To gain access to the front bulbs, loosen screw (1) and pivot the headlamp unit.

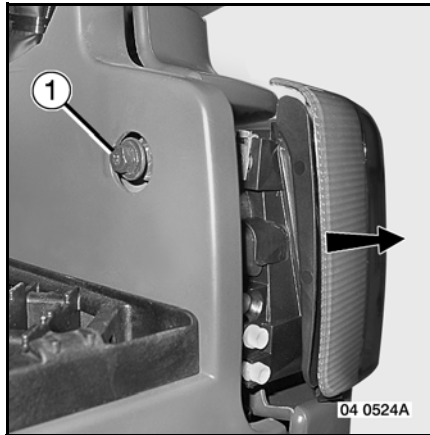

Front flashing lamps

Turn socket (4) through 1/4 of a turn and take it out.

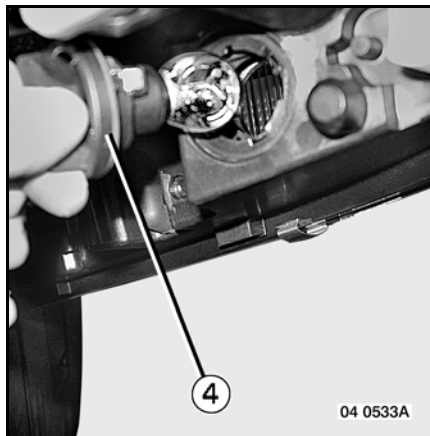

Front side/parking lamps

Turn socket (3) through 1/4 of a turn and take it out.



E3-3 Features - servicing

Dipped beam headlamps (5)

To gain access to the bulbs, remove blanking plug (8).

Main beam headlamps (6)

To gain access to the bulbs, remove blanking plug (7).

Fog driving lamps (2)

To gain access to the bulbs, take off blanking plug (9).

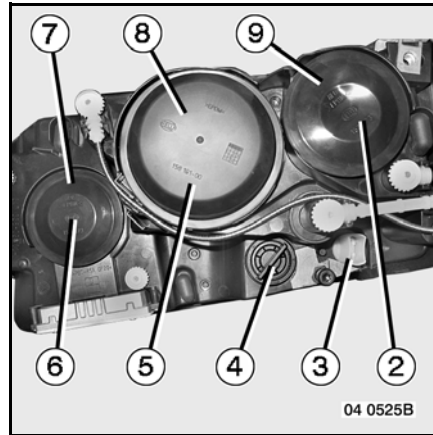

When changing a bulb, carefully put back the rubber or plastic blanking plug to ensure perfect sealing of the headlamp insert unit.



E3-4 Features - servicing

Quartz-iodine bulbs

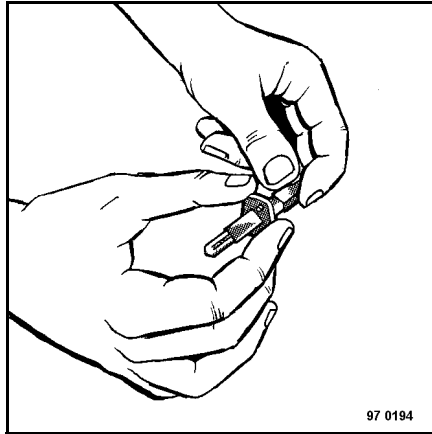

To fit these bulbs, preferably hold them by their metal end-piece. If you have to take hold of them on the glass side, use a cloth or clean paper. The least trace of a fingerprint or grease risks making the bulb ineffective when lighting up. If you are not sure whether the bulb is clean before fitting, clean with methylated spirits. Before removing a bulb, and if it has been previously lit, wait for a few minutes for it to cool down sufficiently to avoid the risk of being seriously burnt.

E3-5 Features - servicing

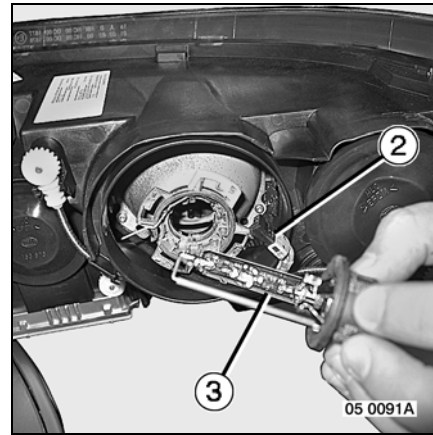
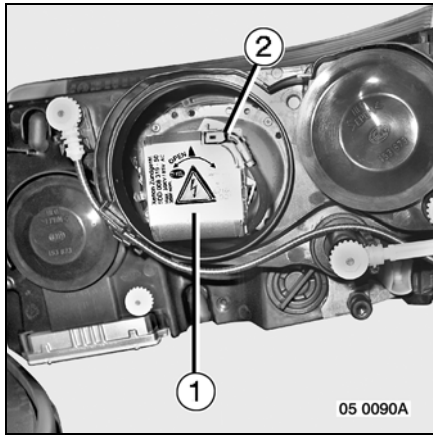

Xenon bulbs

- Turn headlamp module (1) anticlockwise in the "open" direction.
- The power supply connector (2) automatically jumps out under the pressure.
- Withdraw headlamp module (1).
- Unclip and replace bulb (3).
- Put back headlamp module (1) and turn clockwise in the "close" direction.
- Plug power supply connector (2) into headlamp module (1).



Do not plug in the connector (2) as long as the headlamp module (1) is not correctly fastened to the reflector: you run the risk of seriously burning yourself.

If you are unable to refit the headlamp module (1), check that the notches (4) are correctly aligned, if not, re-align them using a small screwdriver.

Take special precautions to not break the bulb, it contains a rare toxic gas.

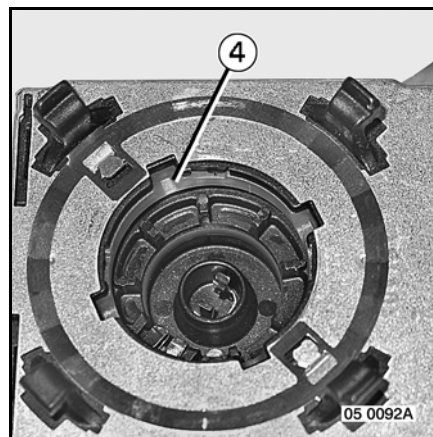

E3-6 Features - servicing

Replacement of side flasher lamp bulbs

Unscrew the securing screw and disengage lamp (1).

Turn the connector / bulb-holder assembly (2) through 1/4 of a turn and take out the bulb.

Replace the bulb and refit in the reverse sequence to removal.

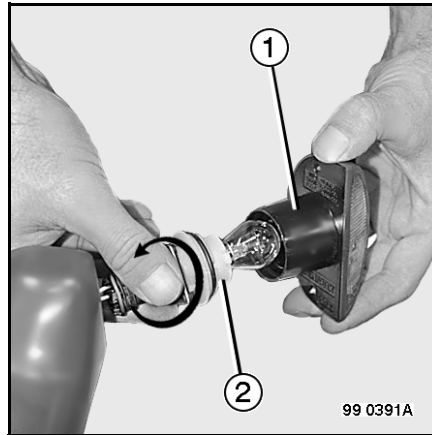

Replacement of side lamp bulbs

Remove attaching screws (1) and disengage the lamp.

Unclip connector (2).

Turn the bulb-holder (3) through 1/4 of a turn and take it out.

Replace the bulb and refit in the reverse sequence to removal.

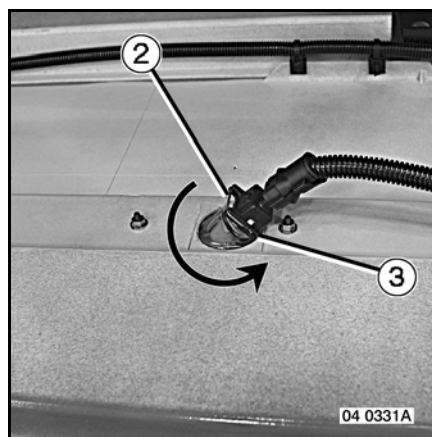
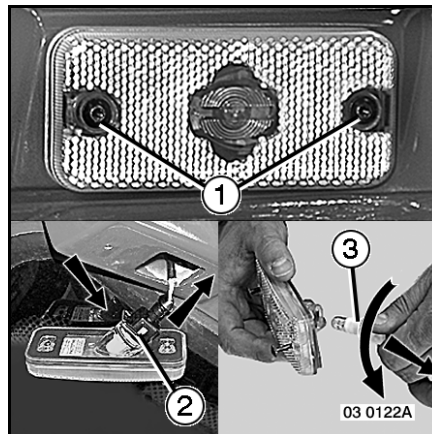

E3-7 Features - servicing

Replacing a roof lamp bulb

Turn the bulb-holder (1) through 1/4 of a turn and take out the bulb.

Replace the bulb and refit in the reverse sequence to removal.

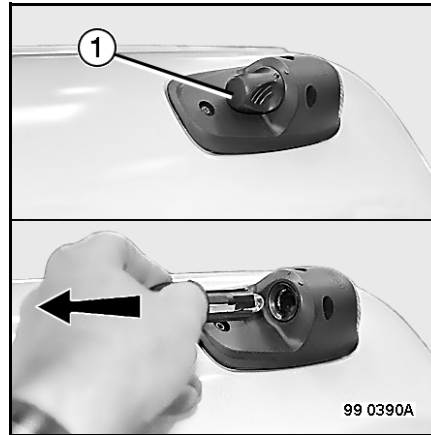

Replacement of a working spotlight bulb (5)

Unclip connector (6).

Turn the bulb-holder (7) through 1/4 of a turn and take it out.

Replace the bulb (8) and refit in the reverse sequence to removal.

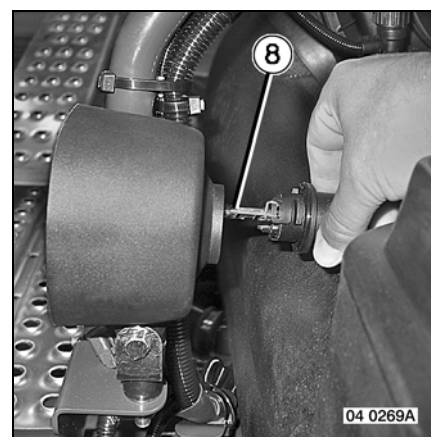
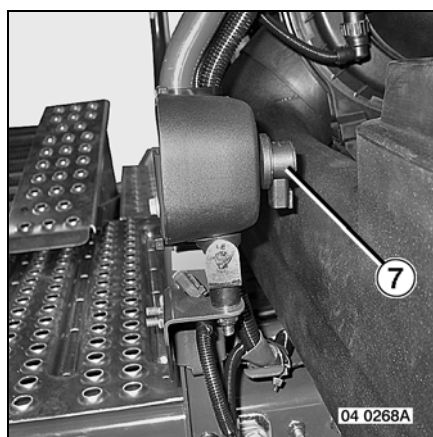
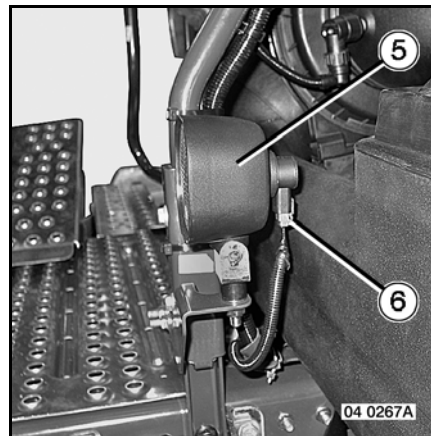

E3-8 Features - servicing

Headlights adjustment

To gain access to the beam adjusters, unscrew screw (1) and pull the headlamp insert.

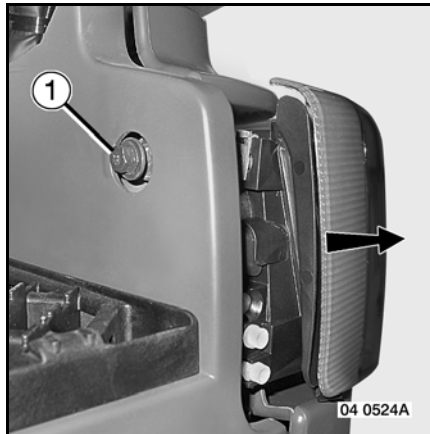

Main beam headlights adjustment

- Beam height (2).
- Main beam parallelism (1).

You are obliged to pivot the headlamp insert unit to adjust the light beam.

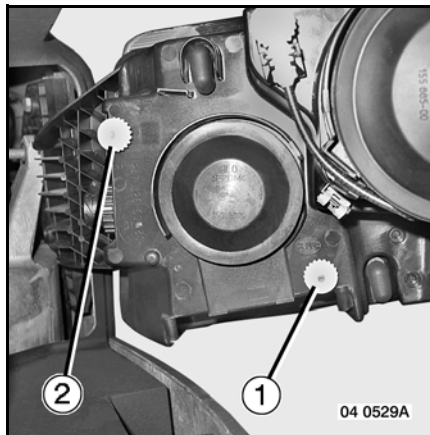

Dipped beam headlight and fog driving lights adjustment

- Beam height (2).
- Dipped beam parallelism (4).
- Fog driving beam parallelism (3).



Any headlamp adjustment work must be carried out in a specialized workshop.

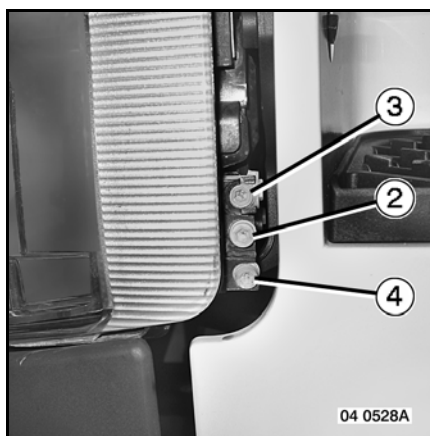

E3-9 Features - servicing

Beam height correction

Depending on your vehicle's equipment

Vehicle unladen: thumbwheel (1) is in position "0".

Vehicle laden: turn thumbwheel (1) to correct the beam height.

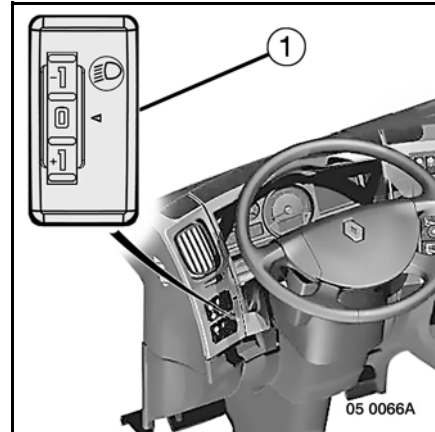

E3-10 Features - servicing

Fuses

To gain access to the fuses:

- Turn the two catches(2) through 1/4 of a turn.
- Remove cover 1/4.

When you have finished, refit cover (1) and turn the catches(1) through 1/4 of a turn.

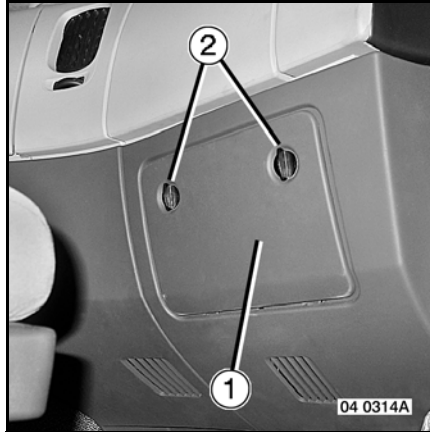

Replace faulty fuses using tweezers (3).

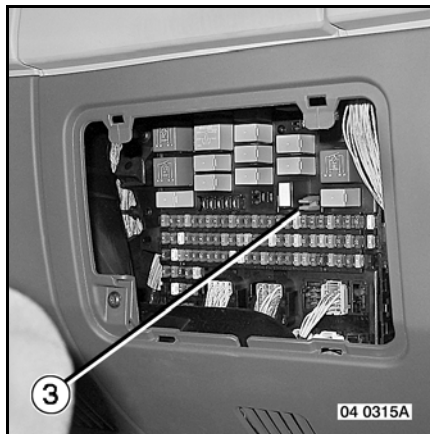

E3-11 Features - servicing

Table of fuses on electrical distribution box

The diagram shows a perspective view of a rectangular electrical distribution box. The top surface is a grid of fuse locations. The labels are arranged as follows:

- Row 1: F01, F02, F03, F04, F05, F06, F07, F08, F09, F10, F11, F12, F13, F14, F15, F16
- Row 2: F17, F18, F19, F20, F21, F22, F23, F24, F25, F26, F27, F28, F29, F30, F31, F32
- Row 3: F33, F34, F35, F36, F37, F38, F39, F40, F41, F42, F43, F44, F45, F46, F47, F48
- Row 4: F49, F50, F51, F52, F53, F54, F55, F56, F57, F58, F59, F60, F61, F62, F63, F64
- Row 5: F65, F66, F67, F68, F69, F70, F71, F72, F73, F74, F75, F76, F77, F78, F79, F80
- Row 6: F81, F82, F83, F84, F85, F86, F87, F88, F89, F90, F91, F92, F93, F94, F95, F96
- Row 7: F97, F98, F99, F100, F101, F102, F103, F104, F105, F106, F107, F108

03 0357A

Always replace a fuse by another fuse with the same rating.

Depending on your vehicle's equipment

Assignment	Item	Amperage
Electric curtains	F2	10
Cab tilting	F3	7.5
Accessories (reversing camera, electronically managed fifth wheel...)	F3	7.5
Information display	F4	5
Windscreen wash / headlamp wash pump and relay	F5	30
Information display	F6	5
Vehicle master ECU	F7	5
Tachograph	F7	5
Alarm	F8	5
Transponder	F8	5
Information display	F8	5
Centralized air management (auxiliary equipment, service...)	F8	5
Central locking	F8	5

E3-12 Features - servicing

Assignment	Item	Amperage
Bodybuilder electronic box power supply (BBM)	F9	5
Air conditioning	F10	30
"ZF" retarder	F11	10
"Optidriver 2" gearbox	F12	10
Automatic gearbox ECU	F12	10
Windscreen wiper motor	F13	20
Cigar lighter	F14	15
Diagnostic socket	F15	5
"INFOMAX" socket	F15	5
Diff. lock	F16	10
Power take-off	F16	10
RH main beam headlamp	F17	10
Horn	F18	10
Air conditioning	F19	5
Onboard radio	F20	10
Doors central locking	F20	10
Alarm	F20	10
"EBS" trailer socket	F21	20
Cab lighting	F22	10
Suspension ECU	F23	5
Fuel preheater	F24	20
Bodybuilder pre-arrangements (van lighting, machine control)	F25	10
Chassis pre-arrangements	F26	15
Windscreen wash motors	F27	20
"EBS" ECU	F28	20
Onboard management	F29	10
Automatic gearbox ECU	F29	10
Dipped beam headlamps	F30	30
Windscreen wiper speed controller	F30	30
Cab heating	F31	20
Customer pre-arrangements	F32	10
Cab tilting pump	F33	30
Onboard management	F34	3

E3-13 Features - servicing

Assignment	Item	Amperage
Automatic gearbox selector	F34	3
Not used	F35	20
Flasher unit	F36	10
Hazard lights control	F36	10
Onboard radio	F37	10
CD loader	F37	10
Hands-free kit	F37	10
Working spotlight	F38	10
Swivelling defrosting rearview mirrors	F39	15
Engine master ECU	F39	15
Engine master ECU	F40	30
Engine master ECU	F41	15
Engine preheating relay	F42	10
Engine fan relay	F42	10
24V / 12V Prises sockets24V / 12V	F43	15
Revolving beacons	F46	15
Centralized air management (auxiliary equipment, service...)	F47	7.5
"EBS" ECU	F48	3
Suspension ECU	F49	5
Piloted steering axle ECU	F51	5
Ignition switch	F52	10
Transponder	F52	10
Onboard management	F54	10
Airbag	F55	5
Seat belt pretensioner	F55	5
Hydraulic retarder control	F57	10
Alternator	F58	3
ADR	F58	3
Onboard management	F59	10
Reversing light(s)	F59	10
Headlights adjustment	F61	15
24 V sockets	F63	15
Trailer socket	F64	10

E3-14 Features - servicing

Assignment	Item	Amperage
Sun-roof	F66	10
Cab lighting	F66	10
"Optidriver 2" gearbox	F67	10
Automatic gearbox ECU	F67	10
24 V sockets	F68	20
Refrigerator	F68	20
12 V socket	F68	20
Trailer "ABS" socket	F70	10
Cab pre-arrangements	F71	15
LH main beam headlamp	F72	10
Heated seat	F75	15
Bodybuilder pre-arrangements box (engine running)	F75	15
Independent heating	F76	10
Hourmeter	F76	10
Customer pre-arrangements	F77	15
Steering wheel fingertip controls	F90	3
LH side/parking lamps	F91	10
RH side/parking lamps	F92	10
Trailer side/parking lamps	F93	10
Bodybuilder pre-arrangement (parking lamps)	F93	10
Trailer side/parking lamps	F94	10
Bodybuilder pre-arrangement (parking lamps)	F94	10
Instrument panel warning lights night lighting	F96	3
Customer pre-arrangements in cab	F97	5
Fog driving lamps	F100	15
Fog lamp(s)	F101	10
Long range driving lamps	F102	10
Reversing lamp(s)	F103	10
Stop lamps	F104	10
Battery direct positive "+"	F105	10
Contact	F106	10
Not used	F107	10
Independent heating	F108	20

E3-15 Features - servicing

Fuses located in battery compartment

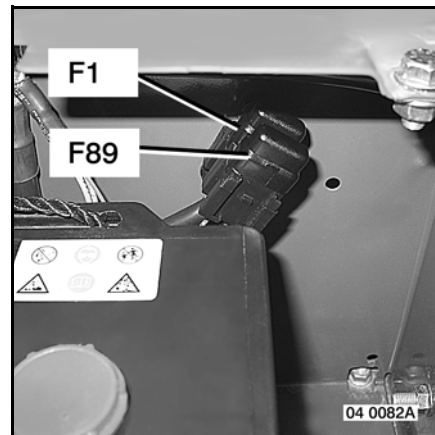

Assignment	Item	Amperage
Flasher unit	F1	25
Independent heating	F1	25
Onboard radio	F1	25
Alarm	F1	25
Central closing	F1	25
Tachograph (non ADR)	F89	5
Tachograph (ADR)	F89	1

E3-16 Features - servicing

Fuses in fuse box (1) located in battery compartment

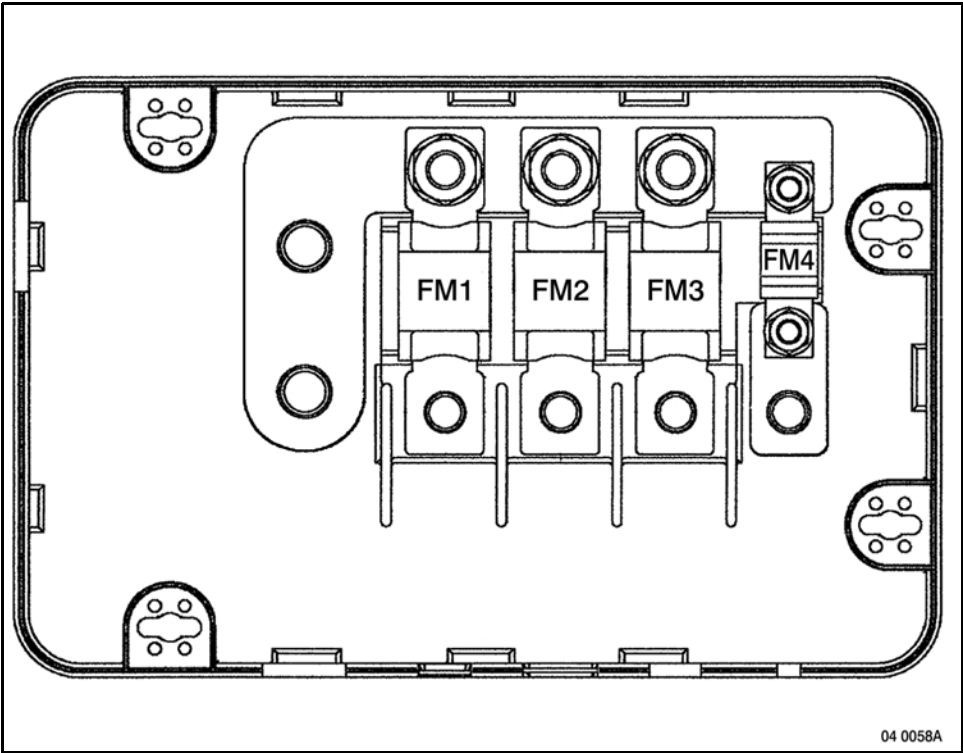
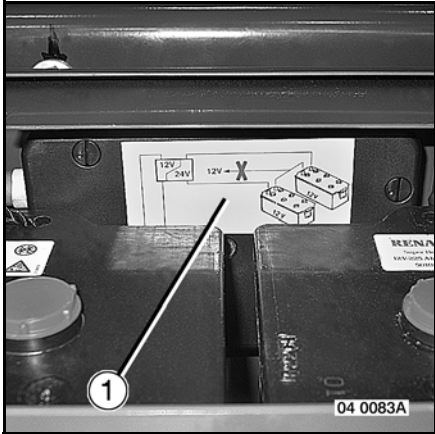

E3-17 Features - servicing

Assignment	Item	Amperage
Cab power supply	FM1	125
Electric tail-lift	FM2	200
Engine intake air preheating	FM3	125
Windscreen defrosting	FM4	40

E3-18 Features - servicing

Remote control battery

Replacing the battery

Using a screwdriver (1), open the casing in the place marked.

Replace battery (2) complying with the polarity engraved on the cover.

Use an alkaline type battery: **CR 2032-3V**.

The battery service life is about 3 years.

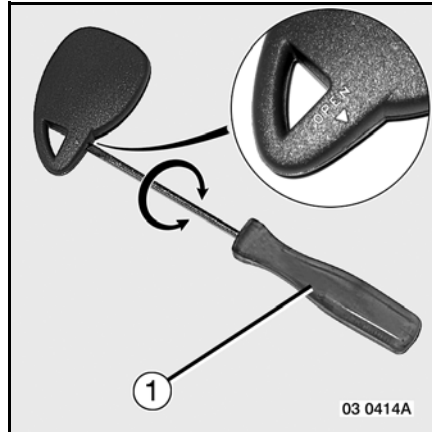

E4-1 Features - servicing

Maintenance instructions

Warranty

Servicing is the prime guarantee.

Recommended inspection and servicing intervals are given as a guide and are intended for vehicles operating under normal road conditions. The tougher the operating conditions, the shorter the service and inspection intervals. In some cases it will be necessary to consider servicing and inspection in terms of hours rather than mileage. The manufacturer cannot be held responsible for damage caused by driving errors, or failure to comply with the recommendations made in this handbook, particularly regarding the use of lubricants that are not in conformity with the performance specifications given.

Topping up engine oil



The engine is to be topped up with RENAULT TRUCKS RLD-2 grade oil until the first service is performed. Subsequently, the choice of oil to be used is defined by the customer according to use of the vehicle.

Implementation of the above checks is essential for the validity of the vehicle warranty. To obtain these inspections, consult your normal RENAULT TRUCKS dealer and give him the warranty certificate you received when the vehicle was supplied.

Lubrication

The manufacturer specifies the performance levels of the lubricants required for the correct operation of the vehicles supplied, and also defines the lubrication intervals.

These recommendations must be strictly followed

Their observance will increase the service life of the equipment and components. Failure to comply can invalidate the warranty offered.



Draining major units: always drain the oils on level ground with the oils hot to aid the flow.

When refitting the drain plugs, fit new gaskets.

E4-2 Features - servicing

Checking the oil levels (all major units).

Oil levels must always be checked on flat ground and conditions should always be identical (i.e. vehicle empty or laden). Wait for 5 minutes after the vehicle has stopped before carrying out the check.



Engine oil level: *for a more accurate reading, the oil level should be checked when the engine is cold, after prolonged shutdown (2 hours minimum), in the morning, prior to start-up, for example:*

- *Vehicle with mechanical suspension: check the level with the vehicle unladen.*
- *Vehicle with air suspension: check the level with the suspension in the 'road' position.*

Road tests

After the warranty inspection, the vehicle manufacturer should make sure that the user clearly understands all the driving and servicing instructions in the handbook.

E4-3 Features - servicing

Fuel

Diesel fuel

If the fixed engine oil change interval is chosen (see page(s) E5-3) it should be halved if the sulphur content is more than 0.3 %.



Use only commercially available diesel fuel for motor vehicles (to standard EN 590). You are advised against using diesel fuel containing additives.

The use of "biodiesel" (with rapeseed oil base) is authorized at a maximum rate of 5% on condition that it meets the requirements of standard EN 590.

You are advised against using diesel fuel containing additives.

The use of diesel fuel containing additives might invalidate the vehicle warranty.

Storage of diesel fuel in drums or jerry cans might allow the ingress of impurities capable of causing fuel supply system malfunction. In such case, it is necessary to filter the diesel fuel before pouring it into the fuel tank.

The use of "aquazole" is strictly forbidden".



IF YOUR VEHICLE IS EQUIPPED WITH A FUEL PREHEATER: THE INCORPORATION OF ADDITIVES (PARAFFIN OR KEROSENE) IS STRICTLY FORBIDDEN.

E4-4 Features - servicing

Lubricants

Adapt the viscosity of the oil used to the climatic conditions of the region in which you use your vehicle.

The use of lower grade oil calls for more frequent oil changes. Your RENAULT TRUCKS service point or dealer is at your disposal to advise you.

For the choice of lubricants according to operating temperatures, see pages E4-7 - E4-9.

Engine oil filter cartridge(s)

For correct operation and long engine service life, use original filters only, where the filtration threshold and filtering area have been designed by the manufacturer.

Engine oil(s)

Renault Trucks Oils	RENAULT TRUCKS specifications
Maxima RD Eco 15 W 30	RD-2
Maxima RD 15 W 40	RD-2
Maxima RLD Eco 15 W 30 ⁽¹⁾	RLD-2
Maxima RLD 15 W 40	RLD-2

⁽¹⁾ Original fitment oil.

RD-2: Specification for RENAULT TRUCKS lubricant to level ACEA E3+VDS-2.

RLD-2: Specification for RENAULT TRUCKS lubricant to level ACEA E7+VDS-3.

ZF gearbox (+ Intarder) oil(s)

Renault Trucks Oils	API standards
Prexima 40	CF- 4 / SF
Longevia Eco 75 W 80 ⁽¹⁾	GL4*
Longevia BXI Eco 75 W 80 ***	GL4*

⁽¹⁾ Original fitment oil.

75 W 80 (GL4*): Synthetic oil conforming to ZF specification: **TE-ML 02D**

***** Longevia BXI Eco:** meets RT POWERTRAIN standard **97307**

E4-5 Features - servicing

Optidriver 2 gearbox oil(s)

Renault Trucks Oils	API standards
Prexima 40	CF- 4 / SF
Longevia BXI Eco 75 W 80 *** (1)	GL4*

(1) Original fitment oil.

*** Longevia BXI Eco: meets RT POWERTRAIN standard 97307

75 W 80 (GL4*): Synthetic oil conforming to ZF specification: TE-ML 02D

VOITH retarder oil(s)

Renault Trucks Oils	RENAULT TRUCKS specifications
Extensia RXD 10 W 40	RXD
Extensia RXD Eco 5W30	RXD
Longevia BXI Eco 75 W 80 ***	GL4*
Prexima 30 (1)	CF / SF

(1) Original fitment oil.

RXD: Specification for RENAULT TRUCKS lubricant to level ACEA 99-E4 and meeting the requirements of test MACK T9 according to specification MACK EO-M PLUS.

*** Longevia BXI Eco: meets RT POWERTRAIN standard 97307

75 W 80 (GL4*): Synthetic oil conforming to ZF specification: TE-ML 02D

Drive axle P 1395 A oil(s)

Renault Trucks Oils	API standards
HD 80 W 90	GL5**
HD Eco 80 W 90	GL5**
Longevia P Eco 80 W 90 (1)	GL5**
Longevia PM Eco 75W90****	GL5**
Longevia PXD 75 W 90	GL5**

(1) Original fitment oil.

(GL5) High temperature extreme pressure oil conforming to oxidation test N° CEC L48A95 at 140° C.**

**** Longevia PM Eco: meets RT POWERTRAIN standard 97312

E4-6 Features - servicing

Drive axle MS 13170

Renault Trucks Oils	API standards
HD 85W140	GL5**
HD Eco 85W140	GL5**
Longevia P Eco 80W140	GL5**
Longevia PM Eco 75W90**** (1)	GL5**

(1) Original fitment oil.

(GL5)** High temperature extreme pressure oil conforming to oxidation test N° CEC L48A95 at 140° C.

****** Longevia PM Eco:** meets RT POWERTRAIN standard **97312**

E4-7 Features - servicing

International standards

Choice of lubricants according to operating temperature

Engine

Oil	Operating temperature
SAE 15 W 30	- 15°C → + 30°C
SAE 15 W 40	- 15°C → + 50°C

ZF gearbox (+ Intarder)

Power take-off

Oil	Mil-L	API	Operating temperature
SAE 40	2104 E	CE / SF	- 10°C → + 40°C
SAE 75 W 80	2105	GL4*	- 25°C → + 40°C

75W80 (GL4)*: Synthetic oil conforming to ZF specification: TE-ML 02 (ZFN 13010)

Optidriver 2 gearbox

Oil	Mil-L	API	Operating temperature
SAE 40	2104 E	CE / SF	- 10°C → + 40°C
SAE 75 W 80	-	GL 4	- 25°C → + 40°C

E4-8 Features - servicing

VOITH retarder

Oil		Operating temperature	
SAE 5 W 30	-	GL 5	- 25°C → + 40°C
SAE 75 W 80	-	GL 4	- 25°C → + 40°C
SAE 10 W 40	2104 E	CF	- 25°C → + 40°C
SAE 30	2104 E	CE / SF	- 25°C → + 40°C

Rear drive axle(s) P 1395 A

Wheel hubs

Oil	Mil-L	API	Operating temperature
SAE 80 W 90	2105 D	GL5	- 25°C → + 30°C
SAE 80 W 90	2105 D	GL5**	- 25°C → + 50°C
SAE 75 W 90	-	GL5	- 35°C → + 40°C

(GL5**) High temperature extreme pressure oil conforming to oxidation test N° CEC L48A95 at 140° C.

Rear drive axle(s) MS 13170

Oil	Mil-L	API	Operating temperature
SAE 75 W 90	-	GL5	- 35°C → + 40°C
SAE 80 W 140	-	GL5	- 20°C → + 40°C
SAE 85 W 140	-	GL5	- 15°C → + 40°C

E4-9 Features - servicing

We recommend Renault Trucks Oils.

Choice of lubricants according to operating temperature

Engine

Oil	Operating temperature
Maxima RD 15 W 40	- 15°C → + 50°C
Maxima RD ECO 15 W 30	- 15°C → + 30°C
Maxima RLD 15 W 40	- 15°C → + 30°C
Maxima RLD Eco 15 W 30 ⁽¹⁾	- 20°C → + 30°C

⁽¹⁾ Original fitment oil.

ZF gearbox (+ Intarder)

Power take-off

Oil	Operating temperature
Prexima 40	- 10°C → + 40°C
Longevia Eco 75 W 80 ⁽¹⁾	- 25°C → + 40°C
Longevia BXI Eco 75 W 80	- 25°C → + 40°C

⁽¹⁾ Original fitment oil.

Optidriver 2 gearbox

Oil	Operating temperature
Prexima 40	- 10°C → + 40°C
Longevia BXI Eco 75 W 80 ⁽¹⁾	- 25°C → + 40°C

⁽¹⁾ Original fitment oil.

E4-10 Features - servicing

VOITH retarder

Oil	Operating temperature
Extensia RXD 10 W 40	- 25°C → + 40°C
Extensia RXD Eco 5 W 30	- 25°C → + 40°C
Longevia BXI Eco 75 W 80	- 25°C → + 40°C
Prexima 30 ⁽¹⁾	- 25°C → + 40°C

⁽¹⁾ Original fitment oil.

Rear drive axle(s) P 1395 A

Oil	Operating temperature
HD 80 W 90	- 25°C → + 30°C
HD ECO 80 W 90	- 25°C → + 30°C
Longevia P Eco 80 W 90 ⁽¹⁾	- 25°C → + 40°C
Longevia PM Eco 75W90	- 35°C → + 40°C
Longevia PXD Eco 75 W 90	- 35°C → + 40°C

⁽¹⁾ Original fitment oil.

Rear drive axle(s) MS 13170

Oil	Operating temperature
HD 85 W 140	- 15°C → + 40°C
HD Eco 85 W 140	- 15°C → + 40°C
Longevia P Eco 80 W 140	- 20°C → + 40°C
Longevia PM Eco 75 W 90 ⁽¹⁾	- 35°C → + 40°C

⁽¹⁾ Original fitment oil.

E4-11 Features - servicing

Hydraulic system(s)

Circuit	Renault Trucks Oils	Standards
Steering	Starmatic 3	ATF DEXRON III
Clutch	Fluid FE 4	SAE J 1703 F / DOT4
Cab tilting T>-15°C	Starmatic 3	ATF DEXRON III
Cab tilting T<-15°C	ST 15M	HV ISO 15
Cab tilting T<-37°C	HGF 26	HV ISO 15
Engine coolant	Ultracooling Plus	RENAULT Type D*
Engine cooling system anti-freeze	Maxigel Plus	RENAULT Type D*

*: Organic

Grease

Symbols	Renault Trucks Oils	Standards
	Superol HP2	NLGI 2 lithium soap grease with lead-free calcium EP additive

Greasing



With grease nipples



Without grease nipples

Location on chassis



2 grease nipples on left



1 grease nipple on right

E4-12 Features - servicing

Lubrication diagram(s)

4x2 rigid and tractor

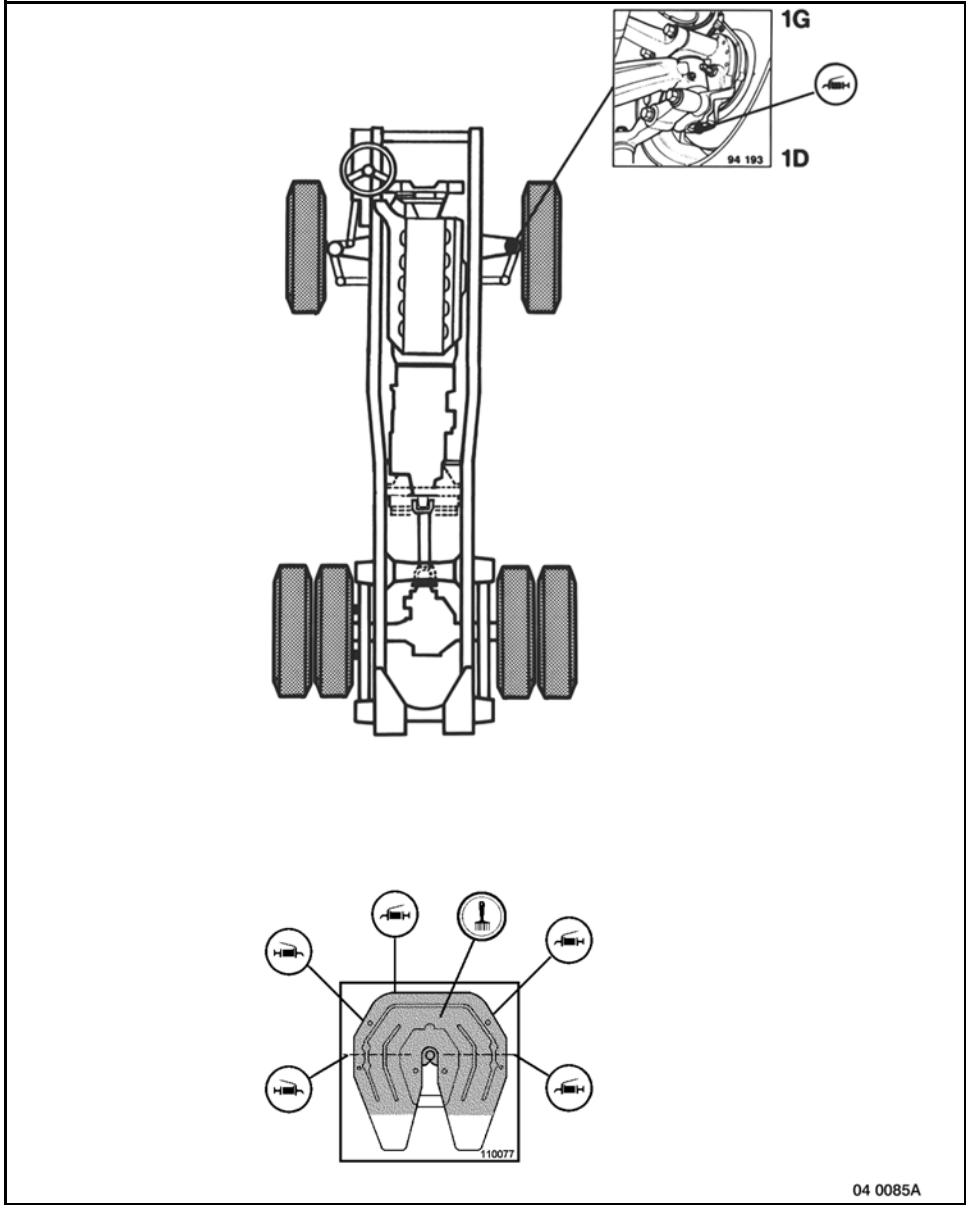

E4-13 Features - servicing

6x2 rigid and tractor

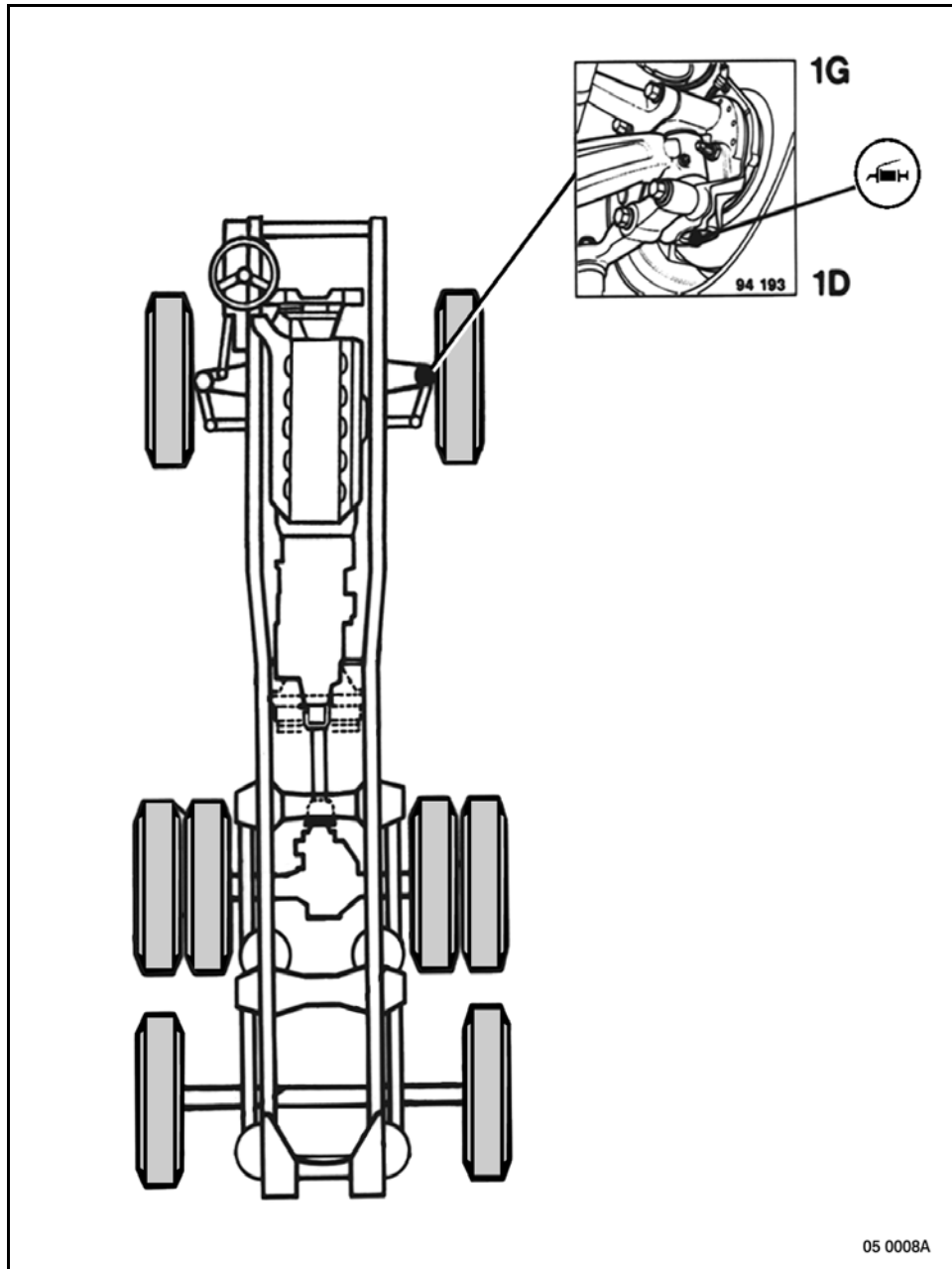

E4-14 Features - servicing

E5-1 Features - servicing

Servicing intervals

Servicing frequencies

Your vehicle is equipped with a system for optimizing servicing intervals in relation to its use.

Maintenance alert warning pictogram is displayed on the instrument panel to warn the driver that the term for a maintenance operation is close or due, based on the works parameter definitions.

If the pictogram is displayed, with the vehicle at a standstill, consult the maintenance menu on the display (see page C2-7) to visualize the term and the maintenance operations concerned.

The display is shown in kilometres, date or engine operating time depending on which term is closest.



No maintenance term specific to the retarder is available on the information display.

The maintenance term for the ZF Intarder is attached to that of the gearbox.

The maintenance term for the VOITH retarder cannot be followed up on the information display.

E5-2 Features - servicing

Table of maintenance features consultable on the dashboard information display in relation to parameter definitions

Component	Fixed	Predictive	km	Date	Time
Engine oil	X*	X	X		
Gearbox oil	X		X	X	X
Drive axle(s) oil	X		X	X	X
Coolant	X		X	X	X
Brake linings	X*	X	X	X	X
Drive belts	X		X	X	X
Air filter	X		X	X	X
APM	X		X	X	X
Regulatory inspection	X			X	
Tachograph inspection	X			X	

x*: Fixed until first maintenance.

New vehicle: only engine and APM maintenance features are active. At the time of the first maintenance operation, it is possible to initialise other components together with the type of maintenance best suited to the usage of your vehicle (predictive or fixed), using the INFO-MAX software or the RENAULT TRUCKS test tool. For that, consult a RENAULT TRUCKS service point or dealer.

Predictive maintenance: means that the terms are formulated by the onboard electronic boxes and vary according to vehicle use.

Fixed maintenance: means that the terms are predetermined and invariable.

E5-3 Features - servicing

Maximum intervals (first term reached)

Major unit(s)	Renault Trucks Oils	Km	
		All uses	
		Fixed maintenance	Predictive maintenance
Engine DXi 11	Maxima RD Maxima RD Eco	Harsh use * 30 000 or 2 years Standard use** 40 000 or 2 years	Term calculated according to use.
	Maxima RLD Maxima RLD Eco ⁽¹⁾	Harsh use* 40 000 or 2 years Standard use** 60 000 ⁽²⁾ or 2 years	

⁽¹⁾ Original fitment oil.

⁽²⁾ On condition that the predictive maintenance feature has not been disabled and the first term has been reached (60 000 km or ignition alert) is fulfilled.

* Harsh use: tonnage more than 44 tonnes, mountain runs .

** Standard use: all other usages.

E5-4 Features - servicing

Unit (s)	Renault Trucks Oils	km	
		Fixed maintenance	
		Harsh use	Standard use
ZF gearbox + intarder Power take-off	Prexima 40	90 000 or 2 years	160 000 or 2 years
	Longevia Eco 75W80 ⁽¹⁾	200 000 or 2 years	300 000 or 2 years
	Longevia BXI Eco 75W80	200 000 or 2 years	300 000 or 2 years
Gearbox Optidriver 2	Prexima 40	90 000 or 2 years	120 000 or 2 years
	Longevia BXI Eco 75W80 ⁽¹⁾	400 000 or 3 years	
VOITH retarder	Extensia RXD Eco 5W30	160 000 or 2 years	
	Longevia BXI Eco 75W80	180 000 or 2 years	
	Extensia RXD 10W40	135 000 or 2 years	
	Prexima 30 ⁽¹⁾	120 000 or 2 years	

E5-5 Features - servicing

Unit (s)	Renault Trucks Oils	km	
		Fixed maintenance	
		Harsh use	Standard use
Drive axle(s) MS 13170	HD 85W140	Forbidden	120 000 or 2 years
	HD Eco 85W140	Forbidden	120 000 or 2 years
	Longevia P Eco 80W140	90 000 or 2 years	120 000 or 2 years
	Longevia PM Eco 75W90 ⁽¹⁾	120 000 or 2 years	240 000 or 2 years
Drive axle(s) P 1395 A	HD 80W90	80 000 or 2 years	120 000 or 2 years
	HD Eco 80W90	80 000 or 2 years	120 000 or 2 years
	Longevia P Eco 80W90 ⁽¹⁾	120 000 or 2 years	240 000 or 2 years
	Longevia PM Eco 75W90	240 000 or 2 years	400 000 or 3 years
	Longevia PXD Eco 75W90	240 000 or 2 years	400 000 or 3 years

⁽¹⁾ Original fitment oil.



1 hour's operation = 50 km.

Every 10 000 km: Grease the fifth wheel locking mechanism and the towing hook.

E5-6 Features - servicing

Engine maintenance operations

M1: At the time of each engine oil change

M3: Every year

MP: Special maintenance (first term reached)

A: Every 800 000 km

B: Every 3 years or 400 000 km

C: Every 3 years or 300 000 km

D: Every 2 years or 400 000 km

E: Every 240 000 km

MAINTENANCE		M1	M3	MP
Drain and refill:				
Engine (see page(s) E5-3)		X		
Engine cooling system and replace pressure/vacuum cap				B
Carry out:				
Replace engine oil filter cartridge(s)		X		
Replace fuel filter cartridge(s)		X		
Replace air filter and clean sediment bowl			X	
Replace drive belt(s)				C
Replace alternator tensioner roller				A
Replace fuel prefilter		X		
Clean:				
Radiator mosquito net by blowing through with low pressure compressed air (or hot water) (Perform this operation early in spring or summer).			X	
Radiators by blowing low pressure compressed air (or hot water) through the core from the engine side (Perform this operation early in spring or summer)			X	

E5-7 Features - servicing

MAINTENANCE		M1	M3	MP
Check:				
Air supply system for leaks (position of hoses, tightness of clamps...)		X		
Operation of air filter clogging indicator		X	X	
Engine for leaks (oil, coolant, fuel)		X		
All levels		X		
Maximum no-load engine speed				E
Condition and tension of drive belts		X		
Air filter inlet grille (clean if necessary)			X	
External cleanliness of radiator cores		X		
Valve clearances				D
Engine brake adjustment				D
Condition and security of fastening of engine cooling system preheater wiring harnesses, connections and gaskets		X		
Condition and secure tightening of engine and radiator rubber sandwich mountings			X	
Degree of protection of cooling system			X	

E5-8 Features - servicing

Clutch, gearbox, power take-off maintenance operations

M1: At the time of each engine oil change

M3: Every year

MP: Special maintenance (first term reached)

B: Every 3 years or 400 000 km

F: at the time of each gearbox oil change

MAINTENANCE		M1	M3	MP
Drain and refill:				
Gearbox (see page(s) E5-3)				X
Power take-off				F
Hydraulic retarder (see page(s) E5-3)				X
Clutch hydraulic system				B
Carry out:				
Replace gearbox oil filter				F
Check:				
All levels		X		
Gearbox for leaks (oil and air)		X		
Hydraulic retarder for leaks		X		
Power take-off for leaks		X		
Clutch hydraulic system for leaks		X		
Clutch servo master cylinder push-rod clearance, slave cylinder travel			X	
Clutch wear indicators		X		
Condition and secure tightening of gearbox rubber sandwich mountings			X	

E5-9 Features - servicing

Drive axle, prop shaft maintenance operations

M1: At the time of each engine oil change

M3: Every year

MP: Special maintenance (first term reached)

MAINTENANCE		M1	M3	MP
Drain and refill:				
Rear drive axle(s) (see page(s) E-5-5)				X
Check:				
All levels		X		
Drive axle(s), hub reduction units for leaks (oil)		X		
Prop shaft(s) play		X		
Secure tightening of universal joint nuts and bolts (prop shaft)			X	

Axle, steering maintenance operations

M1: At the time of each engine oil change

M3: Every year

MP: Special maintenance (first term reached)

MAINTENANCE		M1	M3	MP
Carry out:				
Replace steering fluid reservoir filter cartridge			X	
Check:				
All levels		X		
Hydraulic steering system for leaks		X		
Condition of steering components (hub/swivel play)		X		
Condition of ball-joints and rubber protective bellows seals			X	
Condition and security of attachment of steering lines and flexible pipes			X	
Operation of the steering		X		

E5-10 Features - servicing

Suspension maintenance operations

M1: At the time of each engine oil change

M3: Every year

MP: Special maintenance (first term reached)

MAINTENANCE		M1	M3	MP
Check:				
Condition of suspension springs, pads, front and rear anti-roll bars		X		
Security of attachment and condition of shock absorbers		X		
Air suspension and remote control		X		
Atmospheric venting of electronically managed air suspension pressure sensor connectors		X		

Brakes maintenance operations

M1: At the time of each engine oil change

M3: Every year

MP: Special maintenance (first term reached)

G: Every years or 80 000 km

MAINTENANCE		M1	M3	MP
Carry out:				
Replace APM cartridge				G
Drain water from air tanks		X		
Check:				
Condition of brake pads and discs		X		
Condition and security of attachment of brake lines and flexible pipes			X	
Braking reaction and directional stability		X		
Visually, connection of brake wear sensors		X		

E5-11 Features - servicing

Chassis, cab, electrics maintenance operations

M1: At the time of each engine oil change

M3: Every year

MP: Special maintenance (first term reached)

MAINTENANCE		M1	M3	MP
Carry out:				
Grease all points		X		
Grease all points without grease nipples: door hinges, locks, cab locking, etc...			X	
Fuel tank(s) (drain water)			X	
Check:				
General condition of bodywork (doors, locks, remote control)		X		
Presence and positioning of soundproofing screens and heat shields		X		
Security of mounting of cab (stability, air suspension)		X		
Cab tilting hydraulic system for leaks		X		
Operation of cab locking mechanism by a RENAULT TRUCKS service point or dealer		X	X	
Condition of wiring harnesses, supports, pipes		X		
Operation of dashboard instrumentation (warning lights, pressure gauges, heating controls)		X		
Operation of signalling devices (lighting, headlights, marker lights, stop lights, reversing lights, overhead lights, windscreen wiper, horn, etc...)		X		
Operation of warning lights		X		
Security of attachment of batteries and operation of master switch		X		
Operation of locking and security of attachment of fifth wheel coupling (tractor)		X		
Operation of locking and safety of towing hook locking mechanism (rigid)		X		
Clearance between fifth wheel coupling and semi-trailer (see page E27-1)		X		
All circuits for leaks (fuel, braking, auxiliary equipment, steering, engine cooling)		X		
Atmospheric venting of fuel tank(s)		X		

E5-12 Features - servicing

Heating, air conditioning maintenance operations

M1: At the time of each engine oil change

M3: Every year

MP: Special maintenance (first term reached)

B: Every 3 years or 400 000 km

MAINTENANCE		M1	M3	MP
Clean:				
Fan-coil heater filter		X		
Carry out:				
Replace chilling fluid and dehydrator filter				B
Clean:				
Air conditioner condenser by blowing low pressure compressed air (or hot water) through the core from the rear of the condenser (Perform this operation early in spring or summer).			X	
Check:				
Operation of heater(s) and check for leaks		X		
Operation of independent heater			X	

Wheels, tyres maintenance operations

M1: At the time of each engine oil change

M3: Every year

MP: Special maintenance (first term reached)

H: Every 6 months

MAINTENANCE		M1	M3	MP
Check:				
Condition and wear of tyres, spare wheel and security of attachment		X		
Secure tightening of wheel nuts				H
Inflation pressures of tyres and spare wheel		X		

E6-1 Features - servicing

Engine

Soundproofing screens and heat shields

When a vehicle comes into the workshop, ensure that soundproofing screens and heat shields are present and properly fitted.

Failing this, it is absolutely essential to bring the vehicle into compliance.

After any work requiring the removal of soundproofing screens and heat shields, they must without fail be put back into place, in accordance with the original fitment, and making sure that they do not enter into contact with their surrounds.



After removal, only perfectly clean screens should be refitted.

Pay particular attention that inflammable products (oil, grease...) are never used on the protective films of the screens and shields.

No solvents or paints are to be applied at all on either the inner or the outer faces of soundproofing screens and heat shields.

Any soiled or damaged screen is to be replaced.

In the event of on-vehicle welding or the use of a sanding disk, provide efficient protection to the screens and shields.

Overtightening of screen and shield attaching nuts and bolts may lead to damage.



Any work on fuel or oil systems requires the prior removal of all screens and shields liable to be soiled during the operations.

When cleaning the vehicle, limit the jet pressure to 80 bars maximum, the temperature to 80°C and keep the jet at least 80 mm away from all screens and shields.

E6-2 Features - servicing

DXi 11

Specifications

Power setting	DXi 11 440
Capacity	10 840 cm ³
Bore/stroke	123/152 mm
"DELPHI" fuel- injection equipment	Unit pump injectors
Injection order	1.5.3.6.2.4
Maximum no-load engine speed	2 200 rpm.
Idling speed	600 ^{+50/-10} rpm.

Engine oil capacities

	Litres
Engine dry	36
With filter change	35

Servicing intervals

See page E5-3

E6-3 Features - servicing

Checking the oil level

Tilt the cab.

Check the oil level with dipstick (1).



Always check the oil level on flat ground 2 hours after the engine has been shut-down.

Top up with oil to level, if necessary.

Filler cap (2).

Oil dipstick reading:

- 1- Maximum level
- 2- Minimum level

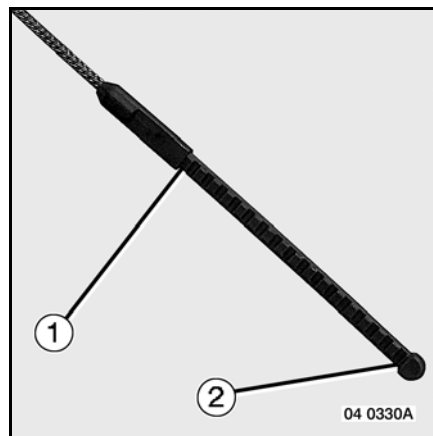
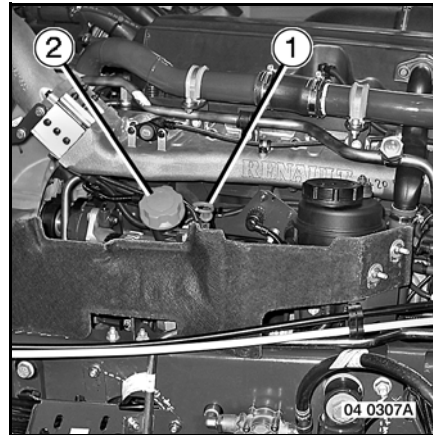

It is always possible for you to top up the engine oil without having to check the dipstick, by following the instructions on the information display.

Filler plug.

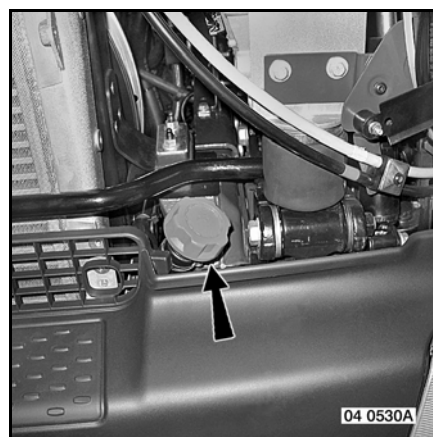

E6-4 Features - servicing

Oil change



Always drain the oil on flat ground.

Remove all soundproofing screens that may risk becoming soiled.

See page(s) E6-1.

Drain plug (3).

Replace the gasket(s).

Tighten to a torque of 57 Nm.

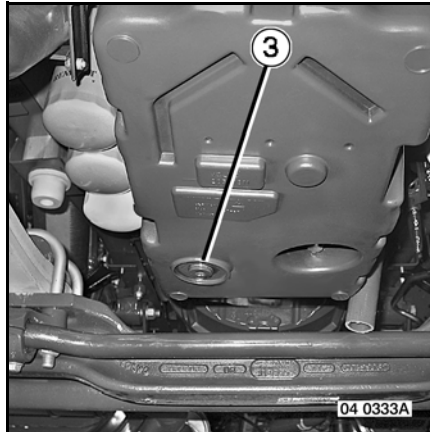

Oil filters

Throw-away oil filter cartridge(s)

To replace, unscrew oil filter cartridge(s) (4).

Upon refitting:

Fill the filter cartridge(s) (4) with oil.

Oil the gasket(s).

Screw up the oil filter cartridge by hand until it makes contact.

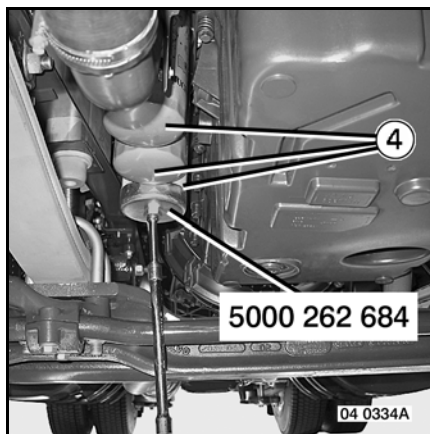

- Tighten to a torque of 25^{±5} Nm.
- Use tool N° 50 00 262 684.
- Use a torque wrench.

E6-5 Features - servicing

Pour oil into the engine through port (2).

Run the engine and check for leaks.

In the event of leakage, remove the filter cartridge, check the joint face and recommence fitting operations.

After running the engine, check the oil level on dipstick (1).

Top up with oil to level, if necessary.

Filler cap (2).

When the work is finished, refit the sound-proofing screens correctly in place.

See page(s) E6-1.

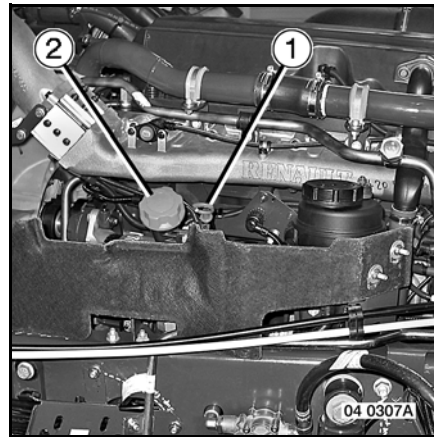

E6-6 Features - servicing

Air filters

Air filter clogging indicator

Check regularly

If warning light (G32) comes on, it means that the air filter cartridge is clogged. Replace the cartridge. At the scheduled intervals, check operation of the clogging indicator by blanking off the filter inlet (with the engine running at 1500 rpm).

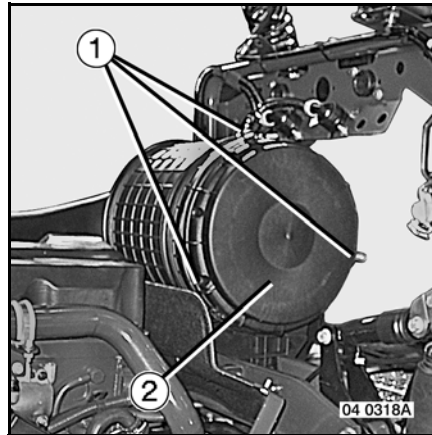

Dry element air filter

When the clogging indicator gives the alert, or once a year, replace primary element (3).

Undo clips (1). Withdraw cover (2).

Remove primary element (3). Turn and pull out the element.

Depending on the assembly, the filter is fitted with a safety element (4). Replace safety element (4) every three primary element changes (3).

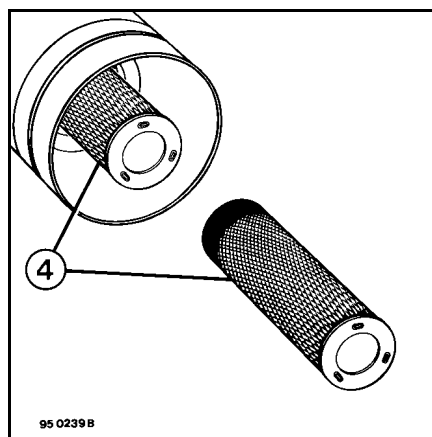
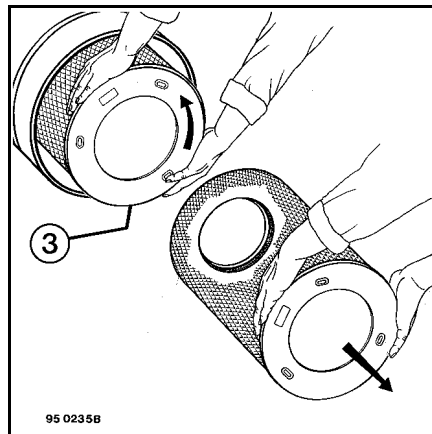

E6-7 Features - servicing

Before fitting the cartridge(s), clean and carefully inspect bowl (6) and the sealing zone (7). This zone must not be damaged.

New cartridges must be free from any signs of knocks or deformation. Especially inspect the sealing zones (8 – 9).

Upon refitting, ensure correct positioning of the cartridges. Exert firm pressure on their ends.

Position the cover according to the pointer.

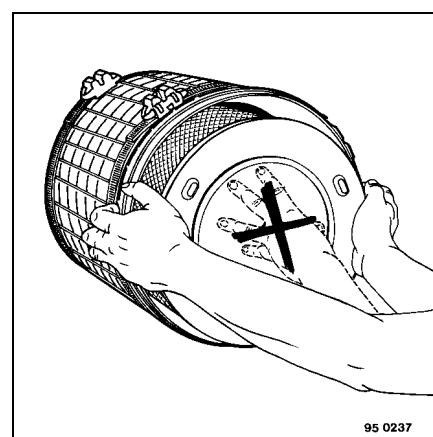
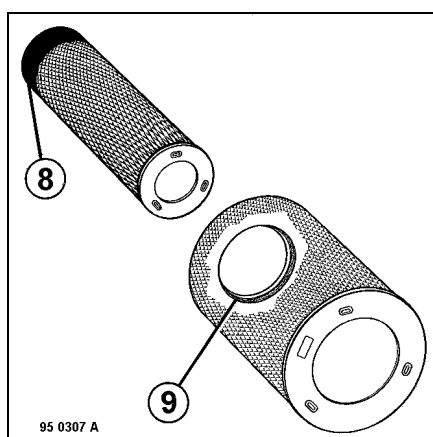
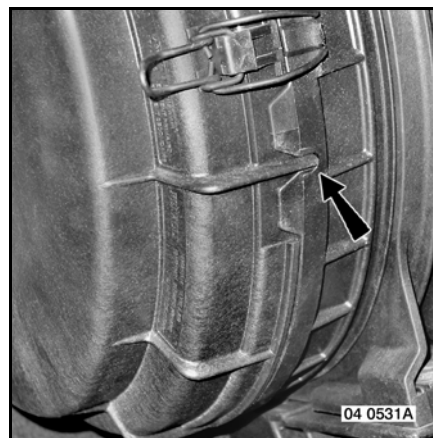
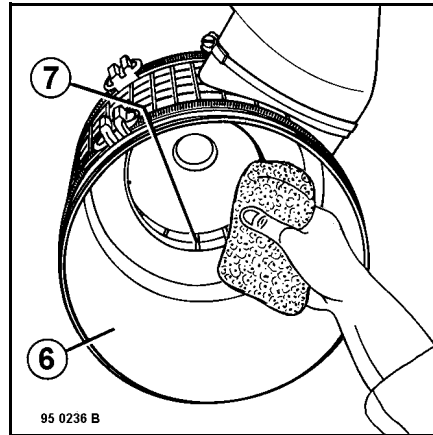

E6-8 Features - servicing

Turbocharger

Turbocharger problems

Indications of incorrect turbocharger operation are lack of engine power, strange noise or the ingress of oil into the inlet manifold.

Should this occur, make your way to the nearest RENAULT TRUCKS service point or dealer. On no account must any internal work be carried out on the turbocharger.



It is essential for heat shields to be fitted to the turbocharger to prevent any risk of fire on the vehicle or damage to surrounding components.



All work on the exhaust line and its brackets requires tightening to torque. Call upon a RENAULT TRUCKS service point or dealer.

E7-1 Features - servicing

Engine cooling

Coolant

	Litres
Cooling system	33.5
Cooling system + ZF INTARDER	51
Cooling system + VOITH retarder	46.5

These capacities are to be decreased by 1 litre for right-hand drive vehicles (smaller expansion bottle).

Engine cooling system

Protecting the system throughout the year

This vehicle is supplied with "ULTRACOOLING PLUS" coolant (a RENAULT TRUCKS OILS product) conforming to RENAULT TRUCKS specifications. Besides its anti-freeze properties, this fluid protects the cooling system against corrosion, scale, etc... It gives frost protection down to - 25°C.

If the temperature drops lower than this, replace a part of the coolant with "MAXIGEL PLUS" antifreeze:

- + 5% "MAXIGEL PLUS" for circuit protection down to - 33°C.
- + 10% "MAXIGEL PLUS" for circuit protection down to - 40°C.



The coolant can remain in the system for 3 years or 400,000 km.

In all countries, whatever the climate or season, exclusively use "ULTRACOOLING PLUS" coolant.

Depending on the destination, the vehicle is delivered with "ULTRACOOLING PLUS -35" coolant (arctic climates). A label affixed to the vehicle indicates this protection.



Under no circumstance should other antifreezes or other coolants be poured into the coolant system. The use of additives is forbidden.

E7-2 Features - servicing

Radiator(s): external cleaning

Once a year, preferably at the beginning of spring or at the beginning of summer, or if the coolant temperature "DANGER" warning light comes on, clean the exterior of the radiator by blowing compressed air or a high pressure hot water/detergent mixture through the radiator core from the engine side.



Never use greasy products such as kerosene, paraffin, diesel fuel, etc...

Radiator mosquito net

If your vehicle is equipped with this accessory, see page E7-2 for servicing.

Radiator mosquito net

Radiator mosquito net

Disassembly:

Remove clips (1).

Disengage mosquito net (2).

Unhook springs (3) and remove the mosquito (2) net.

Cleaning:

Early in spring or summer, clean the radiator mosquito net (2) by blowing through with low pressure compressed air or hot water. Avoid high pressure cleaning jets.

Assembly:

Proceed in the reverse sequence to disassembly. Ensure correct fastening of the mosquito net.

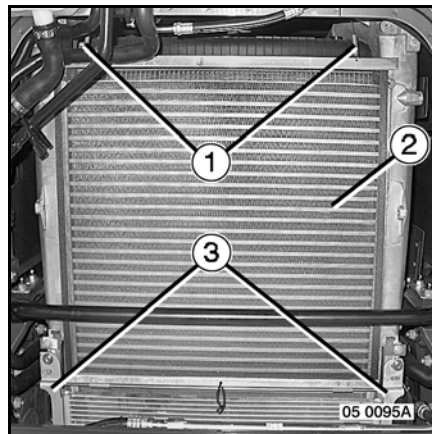

E7-3 Features - servicing

Variable-drive cooling fan

The operation of this fan is managed by the engine electronic system. In the event of cooling fan malfunction, warning pictogram (G9) is displayed on the instrument panel. Get the cooling fan repaired as soon as possible by a RENAULT TRUCKS service point or dealer.

Draining the engine cooling system

Depending on your vehicle's equipment

Open fan-coil heater valve (max. hot).

Engage the master switch.

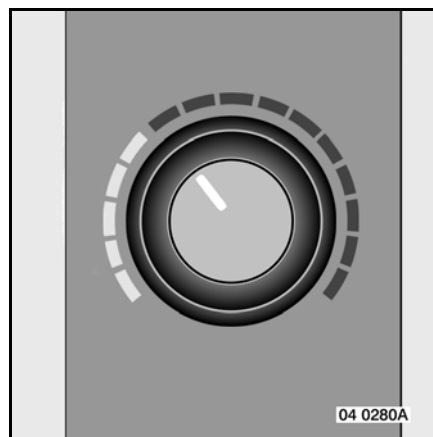

Vehicle equipped with air/water independent heater

Move control (F6) to position (OFF).

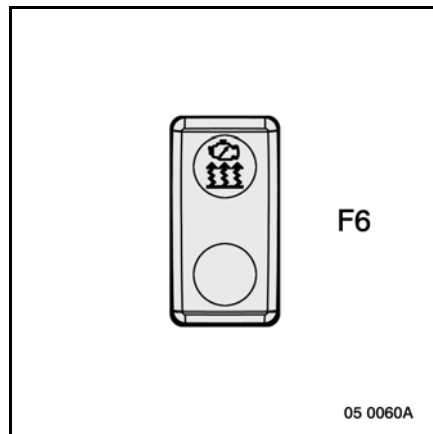

E7-4 Features - servicing

Remove filler cap (2).

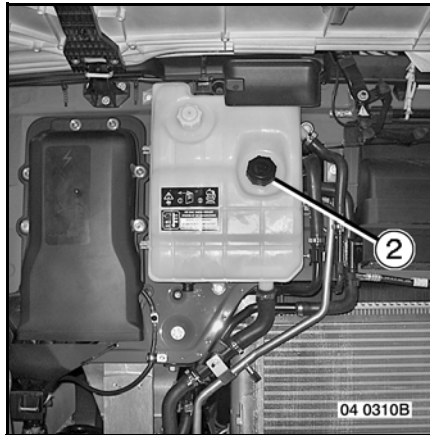

Remove radiator drain plug (3).
Plug tightening torque: 2 Nm.

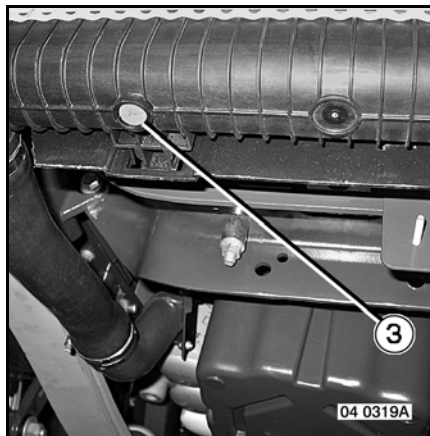

Loosen engine block drain plug (5).
Plug tightening torque: 40 Nm.

RENAULT TRUCKS service points and dealers make use of a flexible pipe 74 09 996 049 for draining the cylinder block without having to loosen the plug (5).

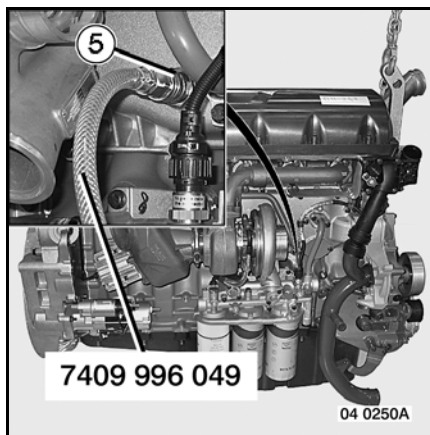

E7-5 Features - servicing

Remove plug (6) (with ZF INTARDER).
Plug tightening torque: 36 Nm.



Remove plug (7) (with VOITH retarder).
Plug tightening torque: 25 Nm.

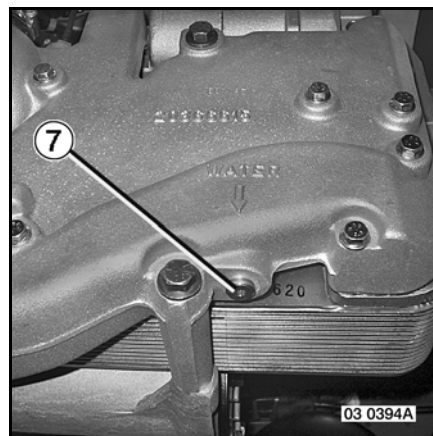

E7-6 Features - servicing

Filling the engine cooling system

Depending on your vehicle's equipment

Check that the drain plugs are quite tight.

Initially fill through the filler (2), pouring the coolant slowly to enable all the air to escape from the system.

Top up with coolant until flush with the port.

Refit filler cap (2).

Start the engine.

Run the engine for 3 minutes at 1 200 rpm, then stop it.

Carefully open pressure-vacuum cap (1).

Check the level and top up, if necessary. Put back filler cap (2).

Run the engine until it reaches its operating temperature (thermostat open), then stop it.

Let the engine cool down and top up with coolant, if necessary.

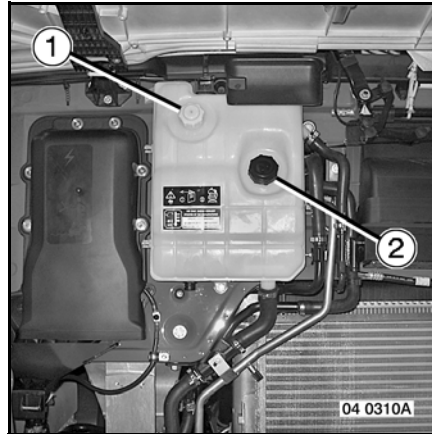

Vehicle equipped with air/water independent heater

Bleed air from the heater. To do so, run the heater for 15 to 20 seconds, operate the electric water circulating pump. Top up with coolant when the heater has stopped.

If the heater trips out, bleed the cooling system once again.



In addition to the dashboard "alert" pictogram (G31), the coolant level in the expansion chamber is visible through a transparent wall.

If for some vital reason the coolant has to be topped up while the engine is hot, first of all carefully release the pressure-vacuum cap (1) by 1/4 of a turn to decompress the system.

Retighten the cap immediately. Then remove the filler cap and top up the coolant.

E8-1 Features - servicing

Fuel system

Fuel tank capacities

Depending on your vehicle's equipment

Steel

	Litres
Fuel tank	255
	315
	330
	365
	415
	445
	450
	505
	610
	630

Aluminium

	Litres
Fuel tank	255
	315
	330
	365
	415
	445
	450
	505
	610
	630
	650
	690
	730
	790

E8-2 Features - servicing

Plastic

	Litres
	215

Steel

	Litres
Extra fuel tank	255
	315
	330
	365
	450

Aluminium

	Litres
Extra fuel tank	255
	315
	330
	365
	450

E8-3 Features - servicing

Fuel filter(s)



Fuel filter(s)

Your vehicle is equipped with a high-performance fuel-injection system.

It is vital to use fuel filters provided for that purpose.

The use of poorly adapted filters can be quite harmful.

Since this fuel-injection system is more sensitive to pollution than in-line pump systems, risks of damage are much higher. Therefore it is essential to assemble genuine, original parts guaranteed by the manufacturer.

Do not modify the diesel fuel system without permission from the manufacturer.

Remove all soundproofing screens that may risk becoming soiled.

(See page E6-1).

Replacement of filter cartridge

Unscrew filter cartridge (1).

Clean the filter housing joint face.

Upon fitting, make sure the gasket is impeccably clean. Lubricate the new filter gasket with engine oil and tighten the cartridges by hand.

When the work is finished, refit the soundproofing screens correctly in place.

(See page E6-1).

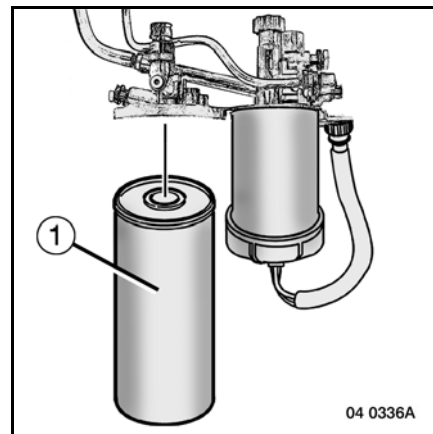

For full reliability, use original filters only.

Do not fill the filter cartridge with fuel before refitting.

E8-4 Features - servicing

Fuel prefilter

Depending on your vehicle's equipment

Draining the sediment bowl

Unplug connector (1) from the wiring harness.

Remove prefilter (2) from the bracket.

Remove sediment bowl (3) from the prefilter

Cleaning

Clean sediment bowl (3) exclusively with diesel fuel.

Check that the drain holes are not obstructed.

When refitting sediment bowl (3) to prefilter (2), lubricate the new gasket with engine oil.

Lubricate the prefilter gasket and place it on the bracket.

Screw up the prefilter by hand and tighten through 1/2 to 3/4 of a turn.

Plug in connector (1).

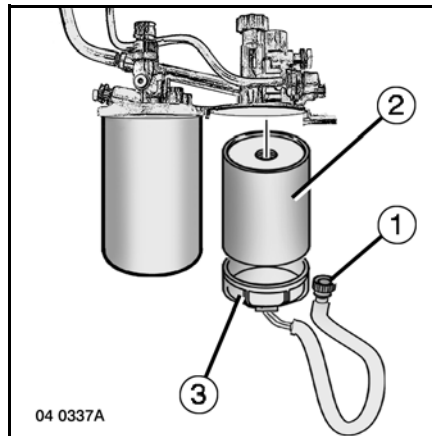

E8-5 Features - servicing

Bleeding the fuel system

Unscrew feed pump plunger (1) then operate it.
Pump until plunger (1) becomes hard.
Screw up feed pump plunger (1).

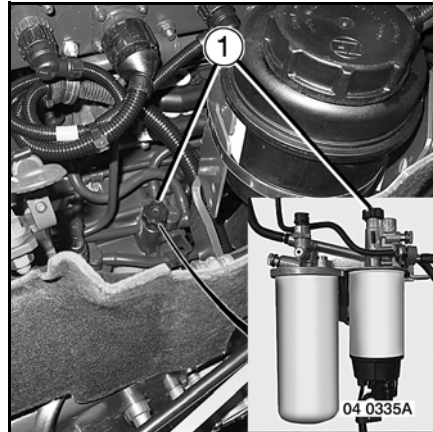

Bleeding water from the fuel / water separator

Press switch (C6): the drain valve opens and the water drains out.

The drainage of water lasts for a few seconds.
The following conditions must be fulfilled so that water can be drained from the fuel / water separator:

- The fuel / water separator sensor indicates a high water level (pictogram (G22) displayed).
- The vehicle is stationary.
- The engine is shut-down.
- The ignition is switched on.
- The parking brake is applied.

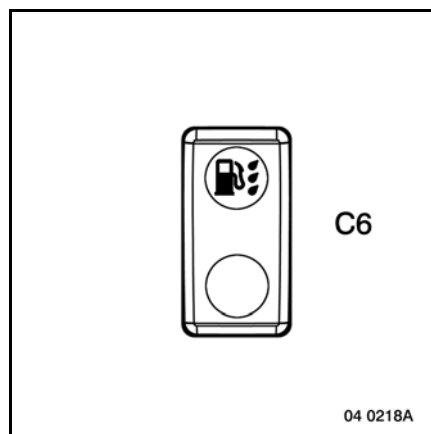

E8-6 Features - servicing

Fuel tank(s)

Fuel filler cap

The filler cap is locked by a key lock (1).

Vehicle equipped with two fuel tanks without changeover valve



Since there is no fuel gauge switch, fuel level gauge (B) shows the total contents of both fuel tanks.

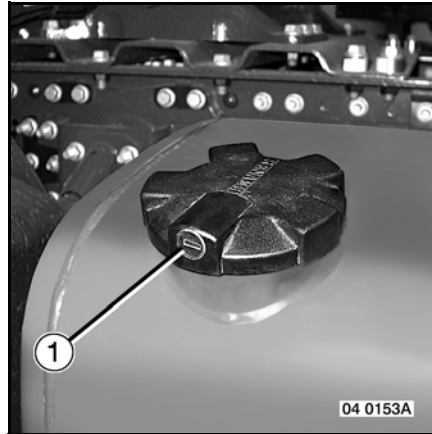

Depending on your vehicle's equipment



SWITCH OFF THE INDEPENDENT HEATER BEFORE YOU FILL THE FUEL TANK(S).

E8-7 Features - servicing

Protecting diesel fuel against freezing and additives

Different makes of diesel fuel are commercially available. The quality of the diesel fuel differs according to the period of use (winter or summer). The filterability limit temperature (FLT) varies according to the type of diesel fuel used. At a temperature close to the filterability threshold, paraffin crystals begin to form in diesel fuel and these block the fuel lines and filters.

To improve its properties when cold, it is possible to add kerosene or petrol to the diesel fuel. Outside winter, the addition of products lowering the viscosity of the diesel fuel is strictly forbidden.

- For protection down to - 15 °C: use diesel fuel Class "E" (TLF - 15 ° C)
- For protection down to - 20 °C: use diesel fuel Class "E" + 20 % kerosene (or paraffin)
- For protection below - 25 °C: use diesel fuel Class "ARTIC 4" (TLF - 44 ° C)



- a) *For maximum efficiency, the additives should be mixed with the fuel at a temperature above 0 °C.*
- b) *In France, do not exceed 30 % paraffin or kerosene (Customs regulations).*
- c) *In other countries, always limit paraffin or kerosene addition to 50 % maximum (check National regulations).*
- d) *However, we recommend that at all times the percentage be kept to the minimum necessary and that paraffin be used in preference to petrol.*



Use only commercially available diesel fuel for automotive vehicles (to standard EN 590.

The use of "biodiesel" (with rapeseed oil base) is authorized at a maximum rate of 5% on condition that it meets the requirements of standard EN 590.

You are advised against using diesel fuel containing additives.

The use of diesel fuel containing additives might invalidate the vehicle warranty. Storage of diesel fuel in drums or jerry cans might allow the ingress of impurities capable of causing fuel supply system malfunction. In such case, it is necessary to filter the diesel fuel before pouring it into the fuel tank.

The use of "aquazole" is strictly forbidden.

E8-8 Features - servicing

Fuel preheater

This equipment serves to lower the filterability limit threshold temperature of the diesel fuel. This filterability limit temperature is different according to the type of diesel fuel used.



If your vehicle is equipped with a fuel preheater: the incorporation of additives (paraffin or kerosene) is strictly forbidden.

E9-1 Features - servicing

Clutch

Clutch types

Depending on your vehicle's equipment

VALEO	430 DTE
SACHS	MFZ 430
SACHS	MFZ 2.400

Circuit capacity

	Litres
Clutch release hydraulic circuit	0.5

E9-2 Features - servicing

Clutch system

Depending on your vehicle's equipment

The clutch pedal clearance should be: 0 mm.
To adjust the clearance, consult a RENAULT TRUCKS service point or dealer.

Hydraulic system

– Check the fluid level in reservoir (1).
The fluid level should be between the "MIN." and "MAX." marks. Top up, if necessary.



Exclusively use the recommended clutch fluid.

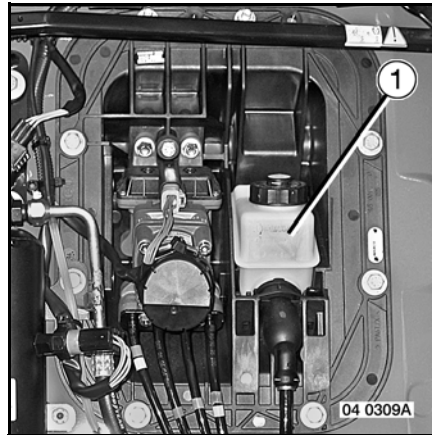

Bleeding the clutch system

Using a pressure bleeder, pressurize the reservoir (2 bar approx.). Bleed the clutch slave cylinder by means of bleed screw (2).

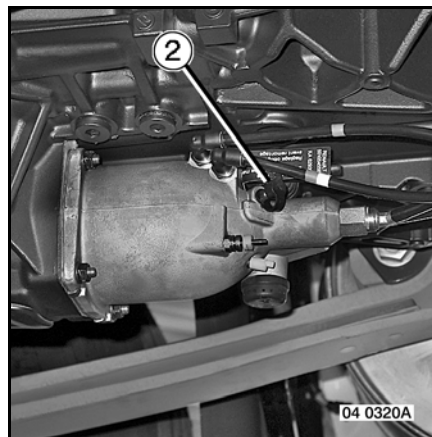

Depending on your vehicle's equipment

Manual gearbox

Clutch lining wear indicator

With the engine stopped, check the driven plate wear (with the clutch engaged).

A : new plate.

B : worn plate.

Clutch type: VALEO 430 DTE

When the value X is equal to $25^{\pm 1}$ mm, the clutch plate is to be replaced.

Clutch type: SACHS MFZ 2.400

When the value X is equal to $34^{\pm 1}$ mm, the clutch plate is to be replaced.

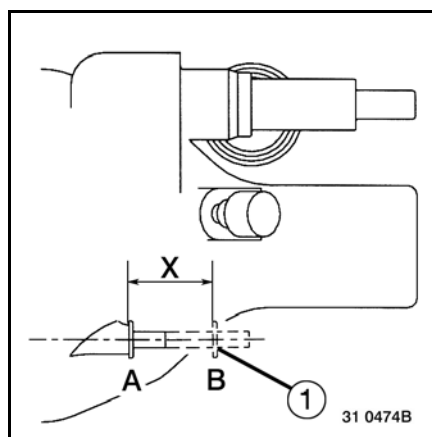

E9-3 Features - servicing

Gearbox Optidriver 2

Clutch type: SACHS MFZ 430

Pictogram (G33) (1) and the message "clutch worn" (2) are displayed when the clutch is to be replaced.

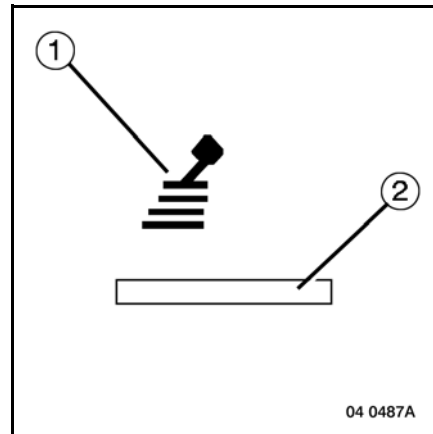

The degree of wear of the clutch can only be determined with the RENAULT TRUCKS test tool

E9-4 Features - servicing

E10-1 Features - servicing

Gearbox

Gearbox types

Depending on your vehicle's equipment

Gearbox	ZF 16S 1620 TD
	ZF 16S 1820 TO
	ZF 16S 1920 TD
	ZF 16S 2220 TO
	ZF 16S 2220 TD
	Optidriver 2

E10-2 Features - servicing

Gearbox oil capacity

Depending on your vehicle's equipment

Gearbox ZF 16S 1620 TD / 1820 TO

	Litres
Normal oil change	8
Sump dry	11
Power take-off	1

Gearbox ZF 16S 1620 TD / 1820 TO + intarder

	Litres
Normal oil change	11
Sump dry	18.5
Power take-off	1

Gearbox ZF 16S 1920 TD / 2220 TO / 2220 TD

	Litres
Normal oil change	10
Sump dry	13
Power take-off	1

Gearbox ZF 16S 1920 TD / 2220 TO / 2220 TD + intarder

	Litres
Normal oil change	18
Sump dry	21.5
Power take-off	1

Gearbox Optidriver 2

	Litres
Normal oil change	13
Hydrocar PTO	1
PTR.D PTO	1.2

VOITH retarder

	Litres
Oil change	5.4

E10-3 Features - servicing

Optidriver 2 gearbox oil change

Depending on your vehicle's equipment

Remove all soundproofing screens that may risk becoming soiled.

(See page E6-1).

Protect the exhaust line against splashing oil.

Draining

Remove plug (1).



Replace gasket(s) and clean the magnet whenever you change the oil.

Refit plug (1).

Plug tightening torque (1): $35^{\pm 5}$ Nm.

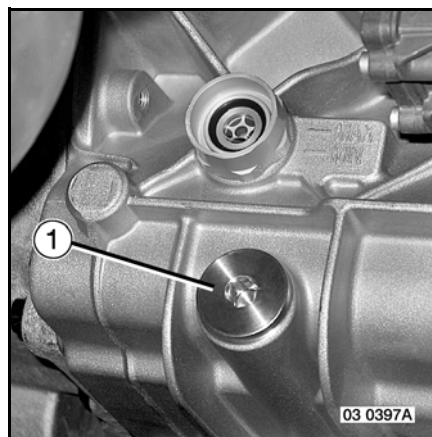

E10-4 Features - servicing

Filling

Remove plug (2).

Fill with oil through port.

Check the oil level through sight (3).

The oil level should be between marks (4) and (5).

Screw up the plug but do not tighten.

With the vehicle at a standstill, run the engine for 5 minutes. Stop the engine and let it rest for 5 minutes. Check the oil level through sight (3) and top up, if necessary.

Tighten plug (2).

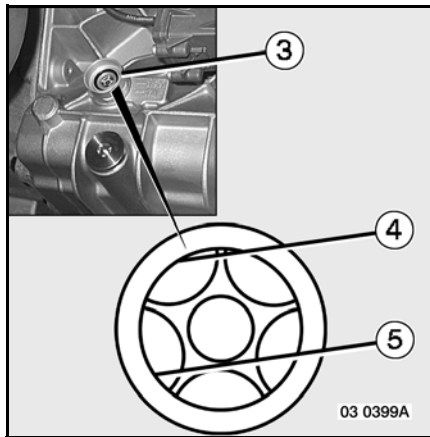
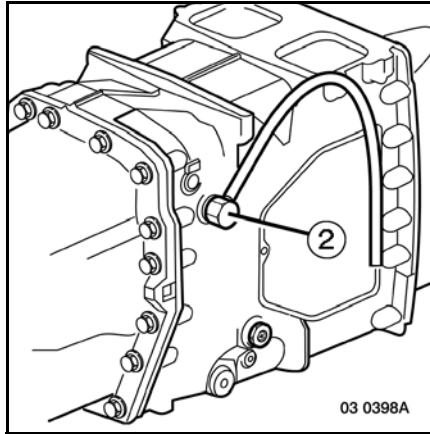

E10-5 Features - servicing

Replacement of oil filter

Remove the setscrews, withdraw cover (A), withdraw gasket (B), remove filter.

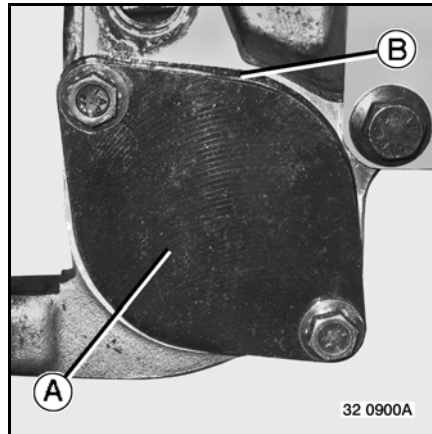

Using inertia tool 0918, remove filter support plate (C).

Clean the cover and gearbox joint face.

Fit a new filter to the shaft. Replace filter support plate gaskets.

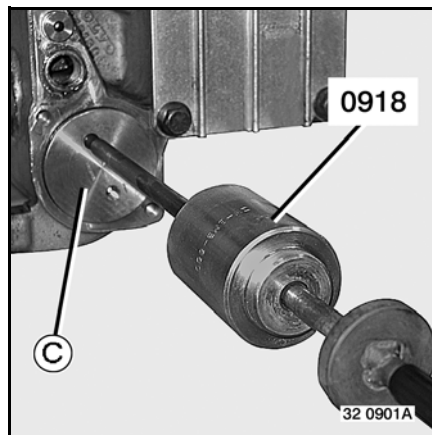

Replace gasket (B).

Fit cover (A). Fit the setscrews.

Tighten the setscrews.



When changing oil and replacing filters on gearboxes with transparent level plugs, fill with oil to the "max." mark. The oil level drops when the oil filter housing fills up.

When the work is finished, refit the sound-proofing screens correctly in place.
(See page E6-1).

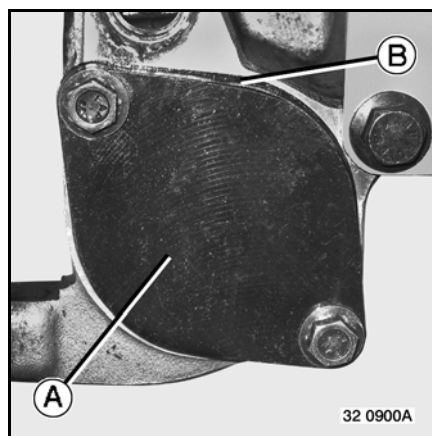

E10-6 Features - servicing

VOITH retarder oil change

Depending on your vehicle's equipment

Remove all soundproofing screens that may risk becoming soiled.

(See page E6-1).

Draining

Remove plug (1).

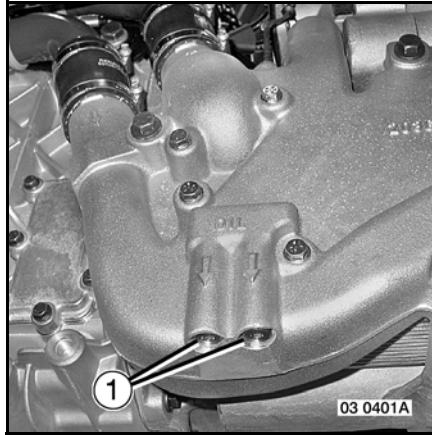

Remove filler plug (2).

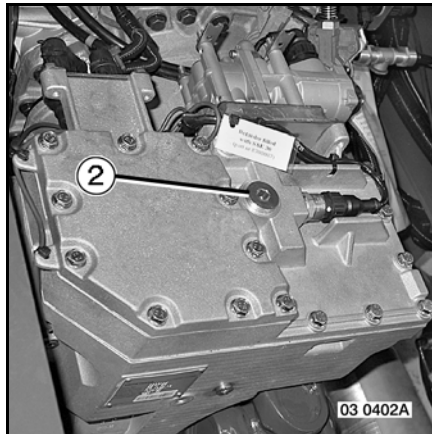

E10-7 Features - servicing

Remove venting plug (3).

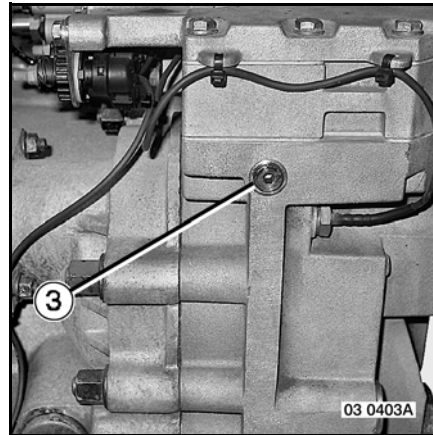

Remove plug (4).
Remove and clean plug strainer.
Replace the gasket.
Refit plug (4) complete with strainer.
Tighten plug (4) to a torque of 100 Nm.

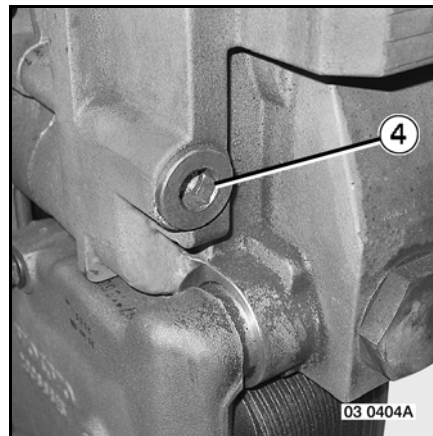

Filling

Replace the gaskets and put back the drain plugs.
Tighten plug (1) to a torque of 20 Nm
Pour the exact quantity of oil into the retarder.
Replace the gasket and put back filler plug (2).
Tighten plug (2) to a torque of 70 Nm.
Replace the gasket and put back venting plug (3).
Tighten plug (3) to a torque of 20 Nm.
When the work is finished, refit the soundproofing screens correctly in place.
(See page E6-1).

E10-8 Features - servicing

Oil change

Type ZF 16S 1620 / 1820 / 1920 / 2220

Depending on your vehicle's equipment

Remove all soundproofing screens that may risk becoming soiled.

(See page E6-1).

Draining

Remove plug (1 - 2).



Replace gasket(s) and clean the magnet whenever you change the oil.

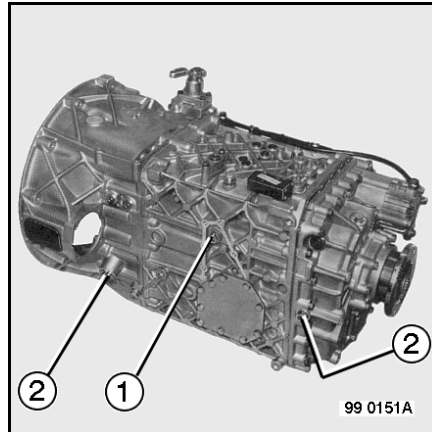

Filling

Fill with oil through port (3).

As soon as the oil overflows, screw up the plug but do not tighten.

With the vehicle at a standstill, run the engine for 5 minutes. Stop the engine and let it rest for 5 minutes. Remove plug (3) and top up the oil level. Refit the plug.

Plug tightening torque (1 - 2 - 3): 60 Nm.

Breather

Wash the breather in diesel fuel and dry it with compressed air before refitting.

When the work is finished, refit the soundproofing screens correctly in place.

(See page E6-1).

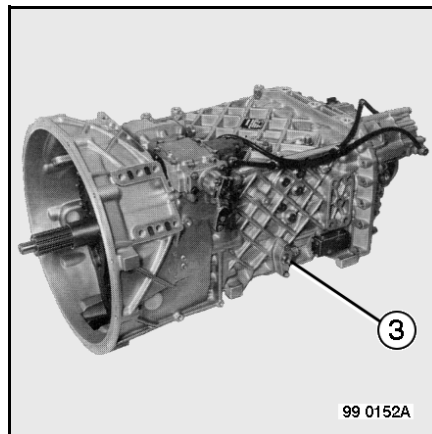

E10-9 Features - servicing

ZF gearbox + Intarder oil change

Depending on your vehicle's equipment

Remove all soundproofing screens that may risk becoming soiled.

(See page E6-1).

Draining

Remove plug (1 – 2 – 4).



Replace gasket(s) and clean the magnet whenever you change the oil.

Plug tightening torque (1): 120 Nm.

Plug tightening torque (2): 60 Nm.

Filling

Fill with oil through port (4). Screw up filler plug (4).

Take the vehicle for a run at a road speed of more than 10 km/h for at least 1 minute, without actuating the ZF Intarder retarder.

Check the oil level at port (4); top up with oil, if necessary, and tighten the filler plug to a torque of 60 Nm.

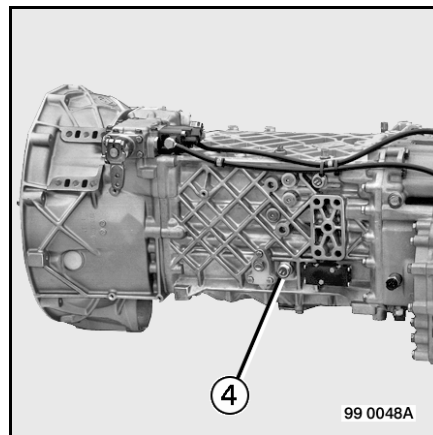
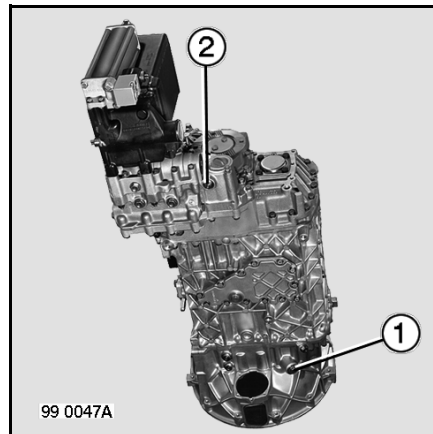

E10-10 Features - servicing

Retarder oil filter replacement

Remove screw (10), take off cover (3), replace filter (6).

Oil O-rings (7 – 8). Fit filter (6). Inspect O-rings (7 – 8). Replace them, if necessary.

Secure magnet (5) to the new filter.

Fit cover (3). Insert screw (10) (tightening torque: 23 Nm).

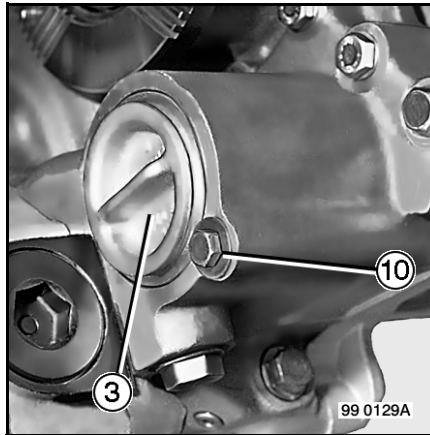

When the work is finished, refit the sound-proofing screens correctly in place.
(See page E6-1).

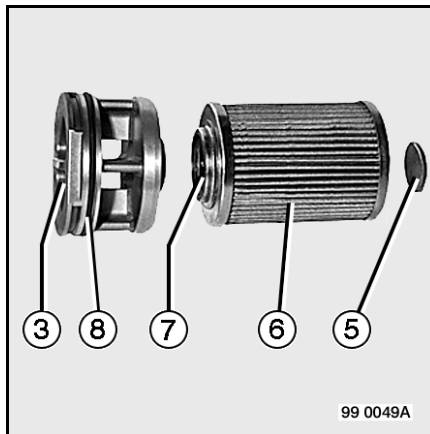

E11-1 Features - servicing

Hydraulic retarder

Retarder types

Depending on your vehicle's equipment

ZF "INTARDER" hydrodynamic brake

VOITH hydrodynamic brake

E11-2 Features - servicing

E12-1 Features - servicing

Power take-off

Power take-off types

Depending on your vehicle's equipment

	N221-10.B/C*
_____	HYDROCAR S81Z1 B/C*
_____	HYDROCAR S81Z2 C*
_____	HYDROCAR S84Z1 B/C**
_____	HYDROCAR S84Z2 C*
_____	PTR.D B/C*

*: Full-time service.

** : Part-time service < 30 min (30 minute interval between two periods of use).

E12-2 Features - servicing

E13-1 Features - servicing

Prop shaft

Prop shaft types

Tubular shafts fitted with universal joints.

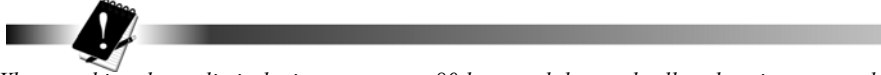

When washing down, limit the jet pressure to 80 bars and do not dwell on bearing cup seals and joints.

E13-2 Features - servicing

E14-1 Features - servicing

Axle

Front axle types

Axle

E 80

Front axle



To avoid any risk of damage to the steering system, it is essential that the stub axle lock stops be adjusted after any changes to the stub axle, steering arms, track rods, etc... Consult a RENAULT TRUCKS service point or dealer.

Track rod clamps



Whenever you touch the nuts and bolts (e.g. when adjusting wheel alignment), you must systematically replace the track rod clamps.

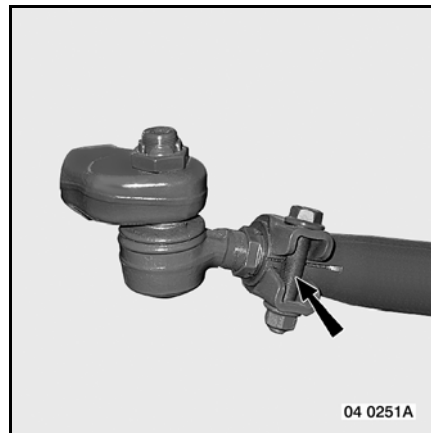

E14-2 Features - servicing

E15-1 Features - servicing

Rear drive axle

Rear drive axle types

Drive axle	MS 13170
	P 1395A

Depending on your vehicle's equipment
With inter-wheel diff. lock.

Oil capacity

Depending on your vehicle's equipment

	Litres
Drive axle (pan) MS 13170	17
Drive axle (pan) P 1395A	16.5
Hub reduction units P 1395A	2×1

Drive axle P13170 oil change MS 13170

Filler plug (2).

Drain plug (3).

Breather

Remove breather (1) and blow through with compressed air before refitting.

If a breather is fitted with a gasket, replace the gasket.

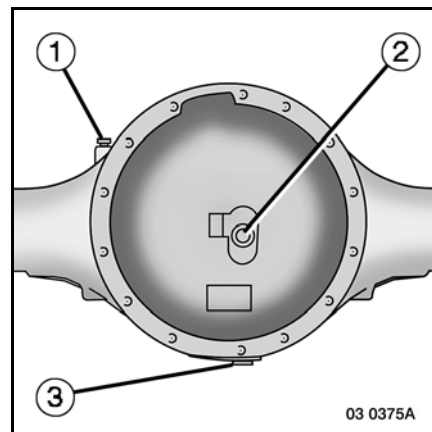

E15-2 Features - servicing

Drive axle P 1395 A oil change

Filler and level plug (2).

Drain plug (3).

Plugs (2 - 3) tightening torque: $80^{\pm 16}$ Nm.

Breather

Remove tube (1) and blow through with compressed air before refitting.

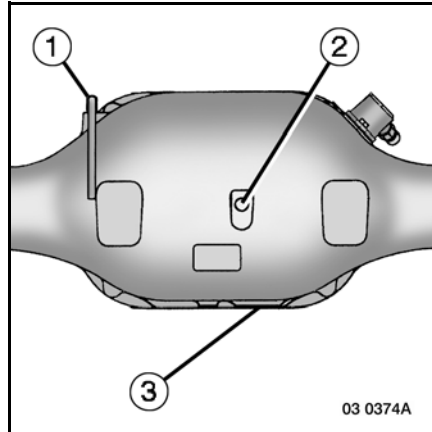

Depending on your vehicle's equipment

Wheel hub reduction units

Drainage:

Remove plug (1) placed in the downwards position.

Filling:

Plug port placed in the upwards position, pour 1 litres of oil into each hub reduction unit, then refit the plug. Any surplus oil will flow into the drive axle pan where the overall level can be checked.

Plug (1) tightening torque: $30^{\pm 6}$ Nm.

Level:

With the arrow pointing downwards, the oil should be flush with port (1).

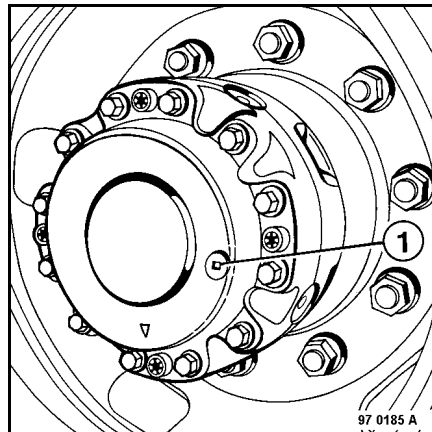

Replace the gasket(s) at the end of each operation and clean the magnet.

E16-1 Features - servicing

Suspension systems

Front suspension

Depending on your vehicle's equipment

Leaf springs, hydraulic shock absorbers and anti-roll bars.

Air suspension.

Rear suspension

Air suspension.

Maintenance

Front suspension

Rear suspension

Suspension components

Shock absorbers do not require any special maintenance. However, at the scheduled intervals, remove them and make sure they are checked by a specialist.

U-bolt tightening torques

Front: 440 Nm.

Rear: 860 Nm.

Anti-roll bar play

At the scheduled intervals, check the play between the bushes and the anti-roll bars.

See pages E5-10.

Air suspension



Never spray oil or diesel fuel on the flexible rubber air bellows or pipes. Regularly check the external condition of the air bellows.

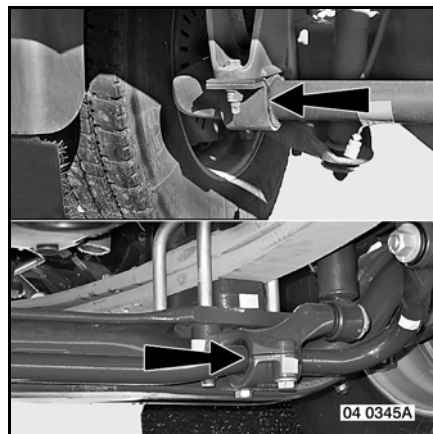

E16-2 Features - servicing

Depending on your vehicle's equipment

Electronic air suspension

Any work carried out on sensors, linkages or controls, or replacement of the electronic control unit, requires the system to be recalibrated. Fault finding and maintenance is to be carried out using the RENAULT TRUCKS test tool plugged into diagnostic socket (3).

Testing and programming operations need to be carried out by a RENAULT TRUCKS service point or dealer.

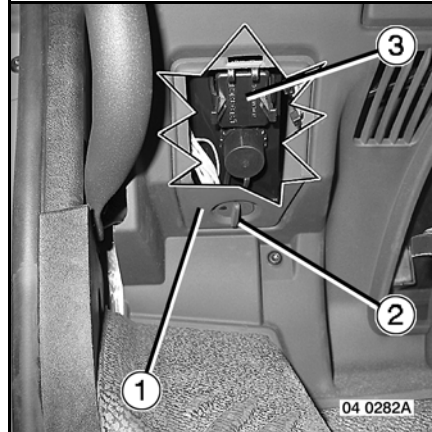

Prior to carrying out any work on the electronic air suspension (other than calibration), place axle stands under the chassis.

E17-1 Features - servicing

Steering

Steering types

ZF 8098

Hydraulic power assisted

System oil capacity

Litres

Power steering hydraulic system

4

Filter cartridge replacement

Remove all soundproofing screens that may risk becoming soiled.

(See page E6-1).

Remove filler cap (1). Press and turn handle (2) through 1/4 of a turn.

Withdraw the cartridge unit. Fit a new cartridge, press and turn handle (2) through 1/4 of a turn so as to engage it under the catches on the reservoir. Check oil level (3).

When the work is finished, refit the soundproofing screens correctly in place.

(See page E6-1).

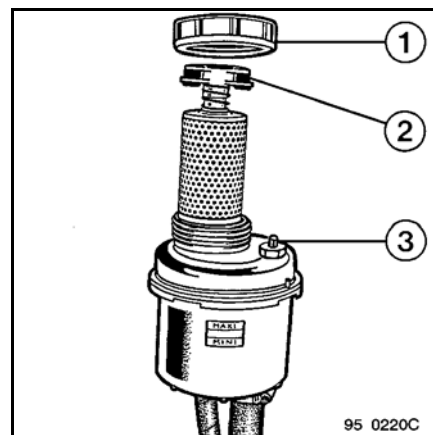

E17-2 Features - servicing

Filling the steering system and bleeding

Raise the front end of the vehicle.

Fill the reservoir with oil via filler (1). When the reservoir level stabilizes, operate the starter a few times to turn the pump - top up accordingly. When the level is stabilized once again, start the engine and run at idling speed. Turn the steering wheel from one lock to the other several times so as to bleed the air from the circuit. Keep an eye on the fluid level (2) during this operation and top up, if necessary. This is to be repeated until the oil level remains constant. Stop the engine and top up the level. Lower the roadwheels back onto the ground.

Continue the lockover manoeuvres on the ground until you can no longer hear any flowing noise and the oil in the reservoir has become clear and is no longer emulsified.

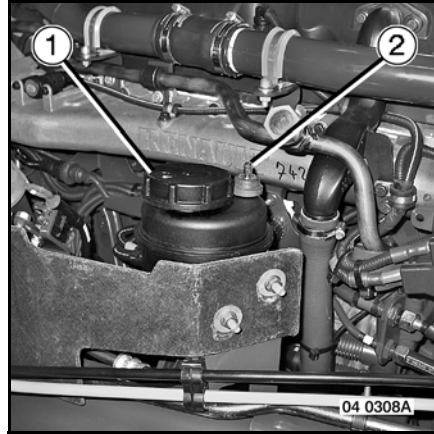

A hydraulic circuit can only operate if it is perfectly clean. The utmost care must therefore be taken to ensure that no dirt enters the system when performing the above operations.

E17-3 Features - servicing

Hydraulic power-assisted steering



When the engine is stopped, the hydraulic power assistance system is inoperative: the effort to turn the steering wheel will be very high .

If the steering becomes hard while you are driving, stop the vehicle and find the cause.

If you experience any incident whatsoever, stop the vehicle and find the cause.

- Check the level in the steering oil reservoir.
- Check for leaks from hose and pipe unions or pipes. If there are, rectify if possible (retighten the unions or change the hoses).

Fill the steering reservoir with clean fluid to the recommended specification. Restart the engine and check that the pump performs normally. Turn the steering wheel a few times at low engine and road speed.

If the steering is still hard or if any doubt remains concerning the pump's efficiency, the steering system must be inspected by a RENAULT TRUCKS service point or dealer.

Under no circumstances must hydraulic components be removed or their initial settings altered. This work must be carried out by a RENAULT TRUCKS service point or dealer.

A hydraulic system can only operate efficiently if it is kept perfectly clean. Great care must therefore be taken to ensure that no dirt enters the system when the above operations are carried out.

E17-4 Features - servicing

E18-1 Features - servicing

Cab tilting

Cab tilting system oil capacity

	Litres
Cab tilting hydraulic system	0.7

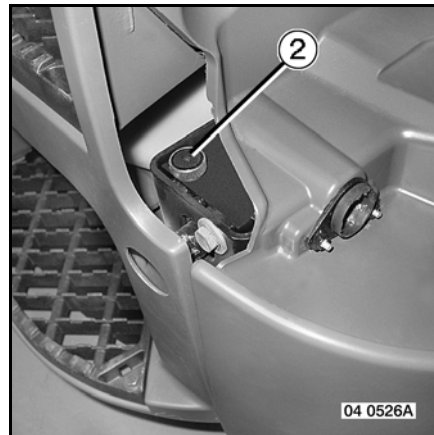

Filler port (2).
See pages B1-20.

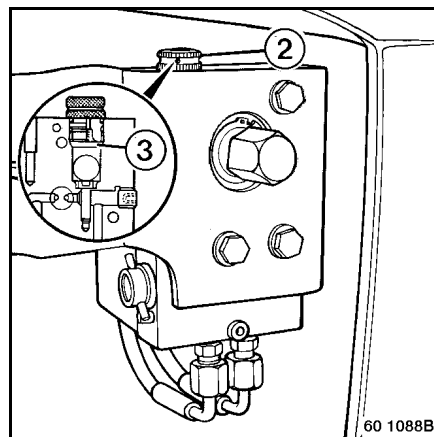

E18-2 Features - servicing

E19-1 Features - servicing

Brakes

Brakes types

Air
"EBS" braking system

Precautions



We remind you that it is forbidden to modify the brake circuit or brake components. Users are advised that they are fully responsible for ensuring that when any additional pneumatic equipment is connected to the vehicle, all the regulations in force are complied with.

This vehicle is equipped with snap-on sealing couplings. If the air pressure in the air tanks drops rapidly when the vehicle is stationary, get the compressed air system checked out by the nearest RENAULT TRUCKS service point or dealer.



**Vehicle equipped with "EBS" braking system:
The alternator and the batteries form part of the system. Their characteristics are integrated in the vehicle type approval dossier. For any modification, contact the nearest RENAULT TRUCKS service point or dealer.**

E19-2 Features - servicing

Brake pads

At the scheduled intervals, or if warning pictogram (G16) is illuminated, check the degree of wear of the brake linings.

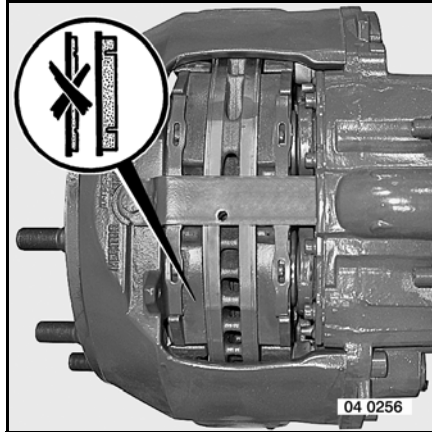

Replacement of one brake pad requires replacement of all the pads on the same axle.

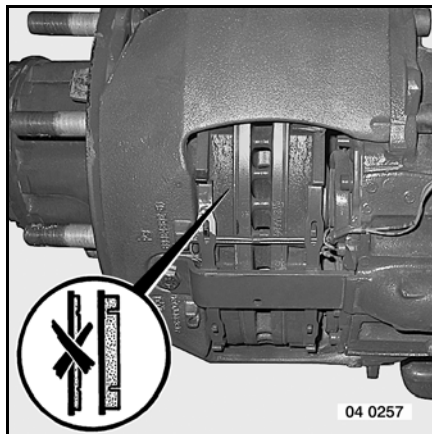

E20-1 Features - servicing

Roadwheels / Tyres

Tyre features

- 1- Tyre type
- 2- Tubeless
- 3- Load index: single fitment
- 4- Load index: dual fitment
- 5- Tyre max. speed symbol

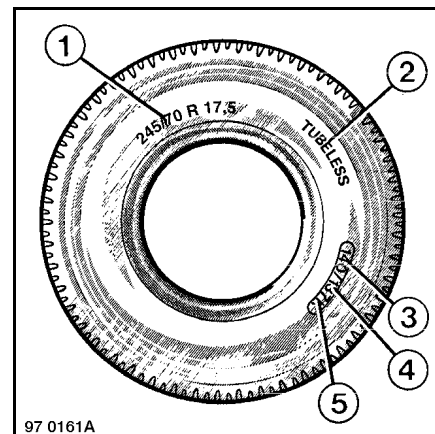

For any modification to tyre type, you must re-programme the braking system parameters without fail. Contact the nearest RENAULT TRUCKS service point or dealer.

Get the tachograph calibrated by an SIM approved workshop.

E20-2 Features - servicing

Tightening the wheel nuts

Tightening sequence

- Disc wheels

Steel wheels

Wheel nuts tightening torque:
 $200^{\pm 8}$ Nm. + $90^{\pm 10}$ °

Light alloy wheels

Wheel nuts tightening torque:
 $200^{\pm 8}$ Nm. + $90^{\pm 10}$ °.

Wheel nuts tightening torque: at least 670 Nm.

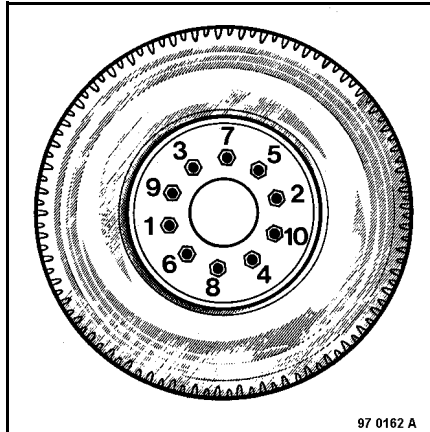

CHECK THE TIGHTNESS OF THE WHEEL NUTS AFTER FITTING A NEW WHEEL OR AFTER A WHEEL CHANGE: AFTER 20 TO 30 KM, THEN BETWEEN 150 AND 250 KM.

CHECK THE TIGHTNESS OF THE WHEEL NUTS EVERY 6 MONTHS WHETHER THE WHEEL HAVE BEEN REMOVED OR NOT.

DURING THE CHECK, IF JUST ONE WHEEL NUT HAS NOT BEEN TIGHTENED TO THE MINIMUM TORQUE OF 670 NM, LOOSEN ALL THE WHEEL NUTS AND RETIGHTEN TO THE RECOMMENDED TORQUE AND ANGLE.

FAILURE TO CARRY OUT THESE ELEMENTARY PRECAUTIONS MAY RESULT IN LOOSENING OF THE WHEEL NUTS AND LEAD TO SERIOUS CONSEQUENCES.

E20-3 Features - servicing

Tyre pressures

Inflation pressures



Follow the tyre manufacturer's recommendations. Follow the tyre manufacturer's recommendations. If they are not available, temporarily use the following pressures given for guidance purposes. For chassis intended to receive equipment liable to modify loads per axle, refer to the manufacturer's data according to make, type and usage. Comply with the loads/speed index marked on the sidewall of the tyre.

Depending on your vehicle's equipment

Tyre type: fitting at front only

Tyre type	Load in kg according to fitment		Pressure in bar
	Single	Dual	
385/65 R 22.5	6 500	-	6.5
	7 000	-	7.0
	7 500	-	7.5
	8 000	-	8.0
385/55 R 22.5	6 500	-	6.7
	7 000	-	7.3
	7 500	-	7.8
	8 000	-	8.4
	8 500	-	9.0

E20-4 Features - servicing

Depending on your vehicle's equipment

Tyre type	Load in kg according to fitment		Pressure in bar
	Single	Dual	
11 R 22.5	4 860	8 960	6.0
	5 220	9 620	6.5
	5 580	10 280	7.0
	5 940	10 940	7.5
	6 300	11 600	8.0
12 R 22.5	5 560	9 880	6.5
	5 950	10 560	7.0
	6 330	11 240	7.5
	6 720	11 920	8.0
	7 100	12 600	8.5
13 R 22.5	5 790	10 340	6.0
	6 210	11 100	6.5
	6 640	11 870	7.0
	7 070	12 630	7.5
	7 500	13 400	8.0
	8 000	13 400	8.0**
275/70 R 22.5	5 010	9 720	7.0
	5 330	10 350	7.5
	5 650	10 970	8.0
	5 980	11 600	8.5
	6 300	-	9.0
	7 100	12 600	9.0
295/60 R 22.5	5 330	9 800	7.0
	5 680	10 420	7.5
	6 020	11 050	8.0
	6 360	11 680	8.5
	6 700	12 300	9.0
295/80 R 22.5	5 560	9 880	6.5
	5 950	10 560	7.0
	6 330	11 240	7.5
	6 720	11 920	8.0
	7 100	12 600	8.5

E20-5 Features - servicing

Tyre type	Load in kg according to fitment		Pressure in bar
	Single	Dual	
305/70 R 22.5	5 660	10 555	7.0
	6 030	11 240	7.5
	6 395	11 920	8.0
	6 760	12 600	8.5
	7 100	-	9.0
	6 700	12 300	8.5**
315/60 R 22.5	5 560	10 550	7.0
	6 030	11 240	7.5
	6 390	11 920	8.0
	6 760	12 600	8.5
	7 100	-	9.0
315/70 R 22.5	5 980	11 225	7.0
	6 370	11 955	7.5
	6 755	12 675	8.0
	7 140	13 400	8.5
	7 500	-	9.0
	7 100	12 600	8.5**
315/80 R 22.5	6 270	11 090	6.5
	6 700	11 860	7.0
	7 140	12 640	7.5
	7 570	13 400	8.0
	8 000	-	8.5
	7 500	13 400	8.0**

** : according to load index and speed symbol.

E20-6 Features - servicing

Advice

Roadwheels - Tyres

Changing a roadwheel

Precautions to be taken when fitting wheels on the vehicle:

Before fitting

Carefully clean the wheel naves and hubs. In particular, clean all contacting parts (remove all grease, earth, mud, metal burrs, excess paint,, etc...).

Upon fitting

Lightly lubricate the studs and nuts (engine oil). Tighten the nuts gradually using the wheel nut spanner provided in the onboard tool kit. Correct tightening is obtained by pulling the tool lever arm.



Overtightening may cause damage. Do not use tubes, bars or other devices to increase the leverage.

In-service checks

Check the tightness of the wheel nuts after fitting a new wheel or after a wheel change: after 20 to 30 km, then between 150 and 250 km.

Failure to carry out these elementary precautions may result in loosening of the wheel nuts and lead to serious consequences.

Principal causes of premature tyre wear

- Manner of driving (excessive braking, driving through potholes, etc...).
- Overloading of the vehicle or bad distribution of loads.
- Over-inflation or under-inflation (inflate to a pressure corresponding to the weight per axle.
- Incorrect pairing (always twin tyres of the same size, type and with the same degree of wear).
- Incorrect front axle geometry.

Tyre inflation pressures (vehicle laden)

See page(s) E20-3.

E20-7 Features - servicing

Checking tyre pressures

Frequency

The tyre pressures must be checked regularly.

Method

The tyre pressures must always be checked when the tyres are cold.

It is essential to never deflate hot tyres.

Safety

In the event of a tyre hitting an obstacle or if it is necessary to stop as the result of a puncture, it is essential to get the tyre immediately checked by a specialist.

Light alloy wheels

Instructions for fitting roadwheels:

To make for subsequent easy removal of the roadwheel, lubricate the hub spigot zone with "FREYLUBE, ROCOL, MG or ESSO MOBY" copper-free grease".



Use only nickel-plated or chromium-plated valves recommended by the Manufacturer. When replacing a valve, lubricate the valve hole and inner seat of the rim with "FREYLUBE, ROCOL, MG or ESSO MOBY" grease.

E20-8 Features - servicing

E21-1 Features - servicing

Heating / Air conditioning

Maintenance

Depending on your vehicle's equipment

Air conditioner

Dehydrator filter

At the scheduled intervals, get filter (1) replaced.

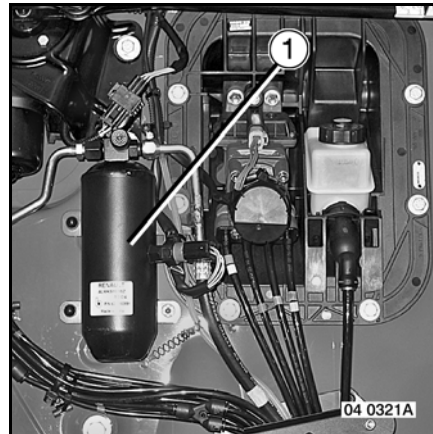

**ANY WORK ON THE CHILLING SYSTEM OR APPLIANCES REQUIRES SPECIAL SAFETY REGULATIONS TO BE MET.
CONSULT A RENAULT TRUCKS SERVICE POINT OR DEALER.**

E21-2 Features - servicing

Fan-coil heater filter

Removal

Remove attaching screws (1), take off the grille and remove the filter.

Cleaning with compressed air

At the scheduled intervals, clean the filter. Apply a maximum pressure of 7 bars. Direct the compressed air jet in the opposite direction to that of filtration. Hold the nozzle at least 5 cm away from the filter.

Cleaning with water

Immerse the filter in a solution of detergent and water for around 15 minutes. Rinse the filter until the rinsing water remains clear. Let dry in the open air or use compressed air.

If the filter shows signs of irregularities, replace it.

Fitting:

Place the filter in position. Ensure correct positioning of the grille and tighten the screws (1).

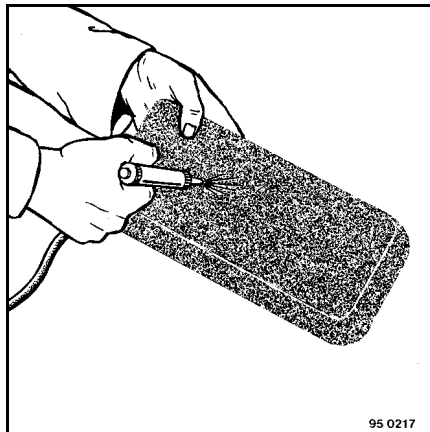
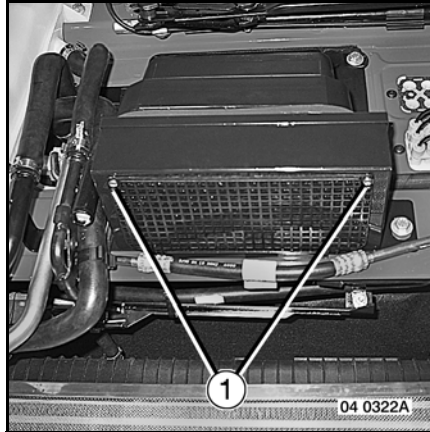

E22-1 Features - servicing

Independent heating

Servicing

At the scheduled intervals, get the heater serviced by a RENAULT TRUCKS service point or dealer.

Outside the heating period, the heater should be run for 1/4 of an hour every month.

Check the suction and discharge ports and clean, if necessary.



If electric welding work is carried out on the vehicle, it is essential to disconnect the batteries to prevent causing irreparable damage to the electronic control system.

Type "Thermo 90 ST" Independent (add-on) heater

When renewing the engine coolant, it is important to bleed air from the heater. To do so, run the heater for 15 to 20 seconds and operate the electric water feed pump. Top up with coolant when the heater has stopped.

E22-2 Features - servicing

E23-1 Features - servicing

Batteries

Features - Servicing

Depending on your vehicle's equipment

2 batteries	170 Ah
	185 Ah
	225 Ah

Before working on the electrical system, disconnect the batteries. Always remove the negative (-) terminal first.

E23-2 Features - servicing

Depending on your vehicle's equipment

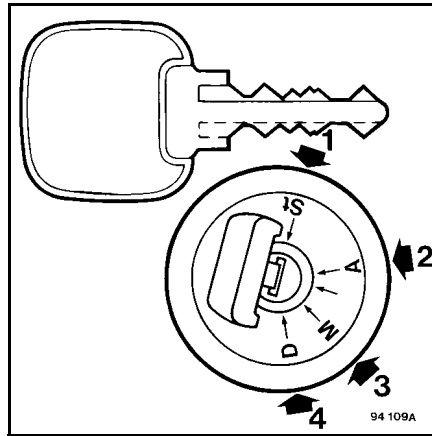

Vehicle equipped with a "Cobra" alarm

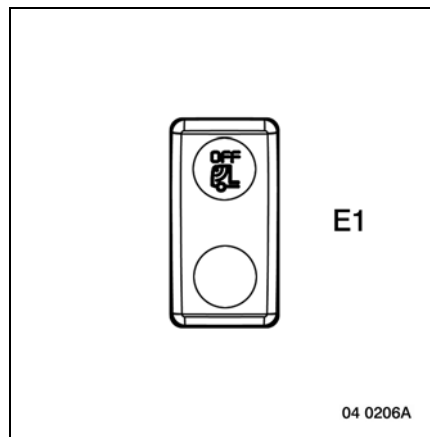

To disconnect the vehicle batteries

Disable the alarm, switch on the ignition (move the ignition key to position (3)), keep volumetric exclusion switch (E1) and remote control locking button (5) depressed. The siren buzzer emits a low intensity sound and warning light (4) on LED box (3) is on steady. Switch off the ignition (move the ignition key to position (1)) and disconnect the batteries.

E23-3 Features - servicing

To reconnect the batteries

Connect up the batteries, switch on the ignition (move the ignition key to position (3)), keep volumetric exclusion switch (E1) depressed and press remote control locking button (6). Warning light (4) on LED box (3) goes out and the alarm is once again set for operation.

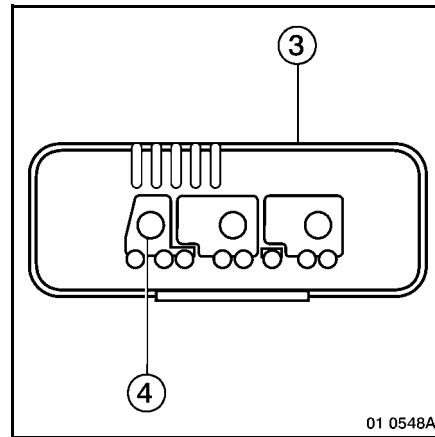

E23-4 Features - servicing

Checking

Prior to checking the electrolyte level, clean the filler plugs and their surrounds. The electrolyte level must stay at 3 cm above the plates. Top up with distilled water, if necessary. Resistance to freezing depends on the state of charge. In addition, the available capacity of a fully charged battery varies with temperature as follows:

100% at 27°C

66% at 0°C

41% at -20°C

Never use a naked flame near the cell vents (risk of explosion).

Checking the state of charge:

Carry out this operation on a battery while in the idle state (battery not having been charged for 2 hours) or after a run: switch on the headlights for 5 minutes, switch them off and wait for 3 minutes before making the check. Measure the voltage across the terminals (battery isolation switch contacts fully open) (see table). This should be slightly higher than the rated voltage. A lower voltage indicates that the battery needs recharging. To ascertain the exact condition of the battery, use a battery tester.

Trickle charge the batteries at 1/10th of their capacity for 10 hours.

No-load voltage (V)	Specific gravit (g/cm ³)	State of charge (%)	Temperature withstood (°C)
12.8	1.273	100	-70
12.6	1.241	80	-45
12.4	1.205	60	-35
12.2	1.170	40	-20
11.9	1.130	20	-15
11.7	1.080	0	-5

If the state of charge is below 80%, recharge the batteries and conduct an electrical check-up on the vehicle.

If a battery has to be removed, always disconnect the negative (-) terminal first.

When refitting a battery, always start with the positive (+) terminal. Terminal post tightening torque: 0.65 daNm.



The difference in specific gravity between cells must not exceed 0.030.

E23-5 Features - servicing

Maintenance-free batteries

For commercial vehicles, this type of battery does incorporate filler plugs. Take the same precautions as for ordinary batteries. However, the trickle charging current should not exceed 1 Amp.

Before using a charger, disconnect the batteries.

If starting with an auxiliary battery, make sure to connect the (+) terminal of the auxiliary battery to the (+) terminal of the vehicle battery and the (-) terminal of the auxiliary battery to the (-) terminal of the vehicle battery.

Incidents involving electrical appliances on tractor vehicles are quite often caused by deficiencies in the electrical installations of trailers. Before hitching up a trailer, carefully check its electrical installation so as to avoid the destruction of fuses, and in particular the earth link.



Overloading the electrical system by adding bulbs or supplementary or more powerful equipment than that for which the system was designed may cause extremely serious damage to all the equipment installed and may produce abnormal discharging of the batteries. Such action will invalidate the manufacturer's warranty.

12 Volts power supply

The supply voltage for the installed equipment must be equal to the vehicle's rated voltage.

Any appliance having a 12 Volts rated voltage needs the use of a voltage dropper.

Connection to the mid-point of the two batteries is strictly forbidden.

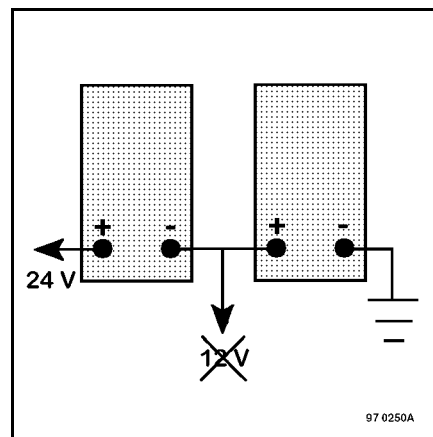

E23-6 Features - servicing

Rational use of batteries

Only fully charged batteries will allow you to start your engine properly.

The original battery / alternator unit enables different electrical equipment to be used and gives optimum battery charging.

Get the charging capacity of your batteries checked regularly. It diminishes in cold weather. In winter, only use necessary electrical equipment.

If numerous accessories (refrigerator, coffee maker, micro-wave oven, television set, independent heater, etc...) are fitted to the vehicle, it is considered necessary to fit batteries with a higher rated capacity. Take advice from your dealer.

The capacity of a battery is expressed in Ampere-hours (Ah).

The consumption of an electrical appliance in amperes (A) is connected with the time of use.

Example: Television set (2A) x 2 hours = 4 A/h.

Engine running: The alternator supplies the energy; the batteries compensate, if necessary.

Engine shutdown: Only the batteries supply the energy.

Limit your consumption and realize that a minimum of 50% of the battery capacity is necessary for starting the engine.

Main appliances and their electrical consumption in 1 hour

- Ignition position = 4 A
- Cab overhead light = 2 A
- Side/parking lights = 5 A
- Refrigerator = 3 A
- "Air" type independent heater = 2 A
- Tail-lift = 150 A
- "Air / water" type independent heater = 10 A
- Coffee maker = 10 A

If the forecast calculation reveals a battery discharge of more than 50%, limit the number of appliances or compensate by intermediate charging (engine running at 1500 rpm for at least 1 hour).



Batteries connected in parallel: the capacities are added together

(2 x 12 V - 14 Ah = 12 V - 280 Ah).

Batteries connected in series: invariable capacity (2 x 12 V - 140 Ah = 24 V - 140 Ah).

E23-7 Features - servicing

Charge indicator

This function is performed by a charge warning lamp (G3).

Charge warning lamp: The charge warning light should remain out when the engine is running. If the light remains on, the charging system is defective.

Starting the engine using an external power source (see page F-1)



**The use of a power charger as starting aid is forbidden
(damage to electronic systems).**

E23-8 Features - servicing

E24-1 Features - servicing

Alternator

Alternator type(s)

Depending on your vehicle's equipment

	Capacity
Alternator "MITSUBISHI"	90 A

Before working on the electrical system, disconnect the batteries. Always remove the negative (-) terminal first.



The voltage regulator is integral with the alternator. Never leave the alternator switched on when the vehicle is stopped (ignition key, master switch). Never break the circuit while the engine is running. Avoid making any connection errors. Never run an engine with batteries disconnected or removed.

Charge indicator

This function is performed by a charge warning lamp (G3).

Charge warning lamp: The charge warning light should remain out when the engine is running. If the light remains on, the charging system is defective.

E24-2 Features - servicing

E25-1 Features - servicing

Starter

Starter types

Starter

Mitsubishi

E25-2 Features - servicing

E26-1 Features - servicing

Compressed air system

APM (Air Production Management) unit

At the scheduled intervals, replace the cartridge.

Replacement of cartridge:

Clean the APM and its surrounds. Fully drain all the air tanks.

Replace cartridge (1). Tighten by hand.



Cartridge with left-hand thread

Get the APM re-initialized by a RENAULT TRUCKS service point or dealer.

Upon assembly, lightly oil the gasket(s).

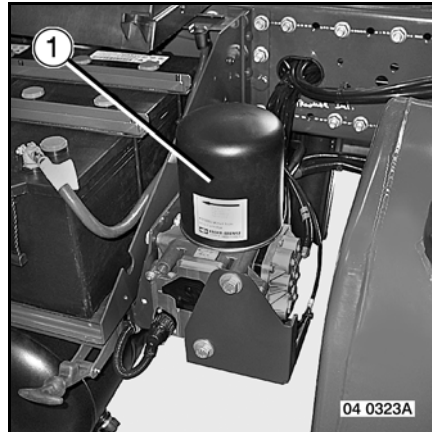

Spent cartridges are to be considered as special industrial waste and must meet treatment regulations. Take the laws in force into account.

Brake valve

This unit does not require any special maintenance. In the event of malfunction, get it checked out by an approved specialist.

E26-2 Features - servicing

Air tanks

Actuate the drain valves (1) to ensure there is no water in the air tanks.

Perform this operation:

- Daily (in winter).
- Weekly (outside winter).

If there is water in the tanks, get the air dryer checked out (see page E26-1).

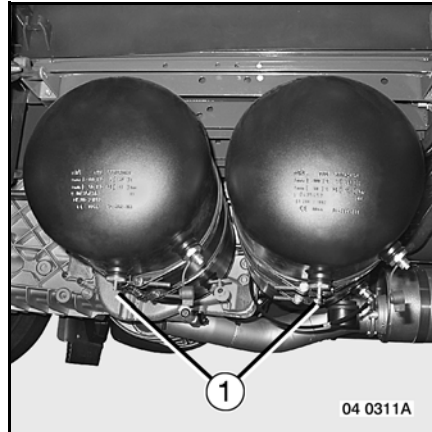

As safety precaution, move the gear lever into neutral before draining the air tanks.

E27-1 Features - servicing

Fifth wheel coupling

Fifth wheel types

Depending on your vehicle's equipment

"GEORG FISCHER" fifth wheel

"JOST" fifth wheel

"FONTAINE" fifth wheel

Inspection / lubrication

At the recommended intervals, check the clearance between the fifth wheel coupling and the semi-trailer. This clearance should not originate from play in either the locking mechanism or the bearings.

- Play in locking mechanism: Check the kingpin. Adjust locking.
If adjustment is impossible, replace the locking mechanism.
- Play in bearings: Check bearings for wear. Replace, if necessary.



The fifth wheel is a coupling unit that must meet extreme safety requirements.

Contact your RENAULT TRUCKS service point or dealer, the original equipment manufacturer or an approved specialist to obtain the tools, gauges and parts needed for inspecting and repairing the fifth wheel.



Grease the fifth wheel before taking the road for the first time.

Every 10 000 km: Grease the fifth wheel locking mechanism.

E27-2 Features - servicing

E28-1 Features - servicing

Cleaning

Washing the body

To prolong bodywork life and maintain the sparkle of the paintwork, we recommend that your vehicle be washed regularly. We advise against the use of brushes, especially during the first few months of use of the vehicle. Do not use a high temperature steam spray.

Neutral washing products are commercially available which do not dull the paintwork.

To remove grease spots, use cleaning fluid (and not petrol or gasoline for motor vehicles).

If the aluminium components are very dirty, clean them with water to which has been added a small amount of non-alkaline washing product, and rinse with clean water.

Washing the vehicle

To limit any risk of incident, do not apply too much water to:

- electronic boxes, electrical junction boxes and electrical appliances.
- window runner seals.
- hinge pins.
- air inlets to heater, engine intake and air filter.
- compressed air units.
- noise baffles and soundproofing screens.



Stop the engine and disengage the master switch before you wash the vehicle. Limit wash jet pressure to a maximum of 80 bar. For soundproofing screens, limit the temperature to 80°C and keep the jet at least 80 mm away from all screens and shields.



When washing the vehicle, grease all points. More particularly, grease the fifth wheel locking mechanism and the towing hook locking mechanism.

Front end

When the front grille is raised, avoid splashing pressurized water.

E28-2 Features - servicing

Cleaning the headlamps

Since the headlamps feature plastic lenses, use a soft or cotton cloth.

If this is not sufficient, use a soft (or cotton) cloth lightly soaked with soapy water.

Rinse with a soft or damp cotton cloth, then dry carefully with a soft dry cloth.

Any other products are strictly forbidden.

Cleaning the cockpit

Spray or wipe a cleaning product on with a rag (soapy water, methylated spirits).

Never use petroleum-based or trichlorethylene-based products.

Lightly coat the door and window seals and runners with talc.

Cleaning the fascia panel

Only use soapy water (and no other product whatsoever).

Cleaning the seats

Plastic parts: Use soapy water or an alcohol-based product.

Fabric parts: Clean with a degreasing product (spirits of turpentine, stain-remover, etc.).

Leather parts: To supple and preserve the gloss of the leather, use a damp cloth. For other products, take a visit to the RENAULT TRUCKS boutique.

F-1 Quick breakdown repair

Starting the vehicle using an external power source

If the engine will not start due to discharged batteries, it is possible to use an external power source (battery cart).

Procedure:

- Disengage the master switch.
- Connect up the battery cart, while ensuring correct polarities.
- Engage the master switch.
- Actuate the starter.
- Run the engine at a speed of **1 300 rpm for about 5 minutes.**
- Switch on the dipped beam headlights then lower the engine speed to idling.
- Let the engine run at idling speed for 1 minute.
- Disconnect the battery cart, starting with the negative terminal.
- Switch off the headlights.

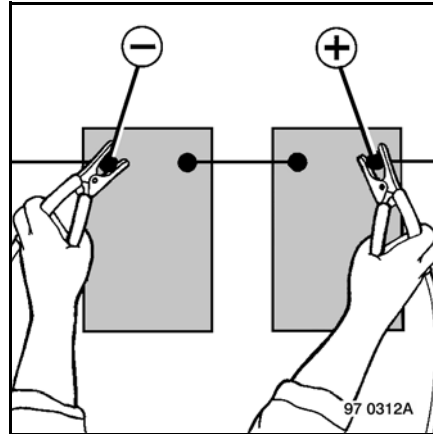

The use of a power charger as starting aid is forbidden (damage to electronic systems).

F-2 Quick breakdown repair

Location of jack and onboard kit

Depending on your vehicle's equipment

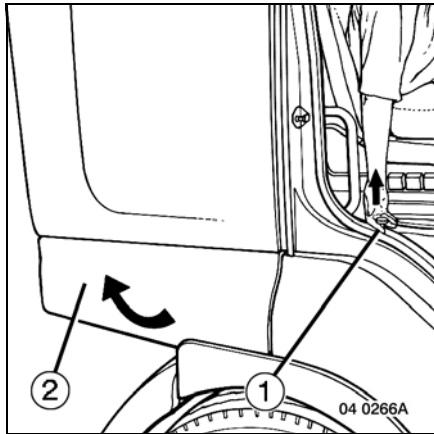

Cab external locker

Opening: Pull handle (1) to unlock the door. Lift up the door (2). A hard spot holds the door open.

A light fitted with a switch comes on when the master switch is engaged.

Closing: Push handle (1), close the door (2). Locking is automatic.

Chassis tool locker

Opening the locker

Turn handle (2) and open locker (1).
The locker is provided with a lock.

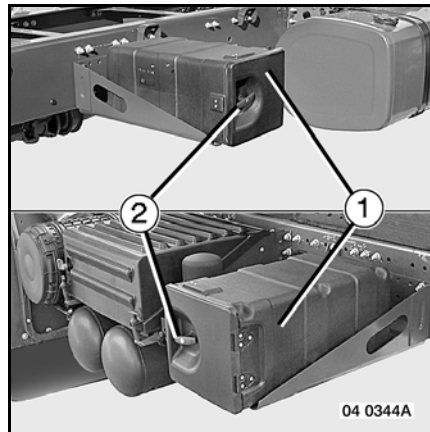

F-3 Quick breakdown repair

Arrangement of tools in the locker

- Jack (3)
- Wheel wrench (4)
- Tool kit (5)
- Cab tilt operating bar (6)
- Jack and wheel wrench handle (6)
- Towing yoke (7)
- Jack mounting plate (8)
- Advance warning triangle (9)

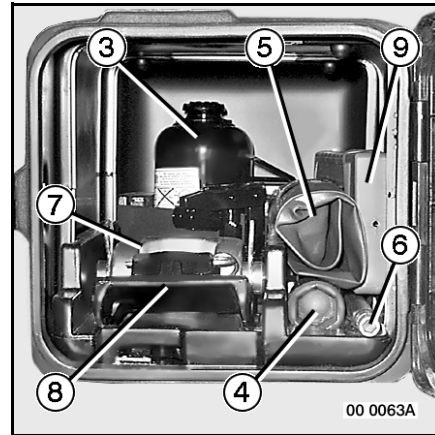

F-4 Quick breakdown repair

Spare wheel carrier

Depending on your vehicle's equipment

Removal

Remove the fairing.

Remove the nuts (1 – 2) and turn the winch to lower the wheel (3).

Fitting

Hoist up the wheel using the winch (3) and lock the nuts (1 – 2).

Fit the fairing.



Lock the spare wheel on the spare wheel carrier, then slacken the winch rope.



Depending on your vehicle's equipment, the jack may be housed in the spare wheel carrier.

Removal

Remove bolt (2) from the fairing to gain access to jack (1).

Loosen locknut (3) and unscrew jack knurled wheel (4).

Fitting

To fit, proceed in the reverse sequence to removal.

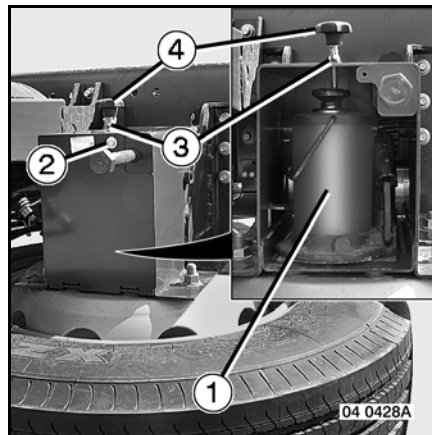
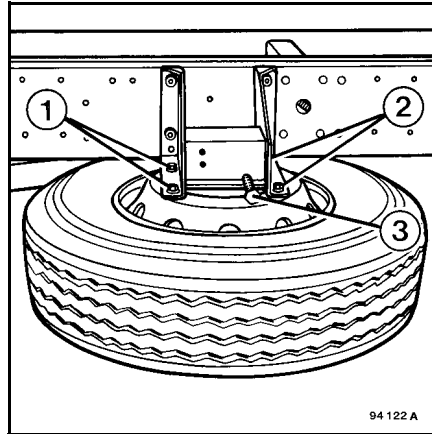

F-5 Quick breakdown repair

Using the jack

Depending on your vehicle's equipment

Front end support points (1)

It is essential to use the adapter (2) by fastening it to the head of the jack with two split pins (3). Place the jack as close as possible to the axle.



Chock the rear roadwheels.

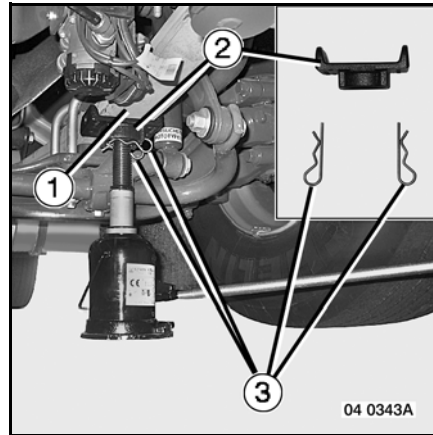

If necessary, use the jack tommy bar to disengage the adapter (2).

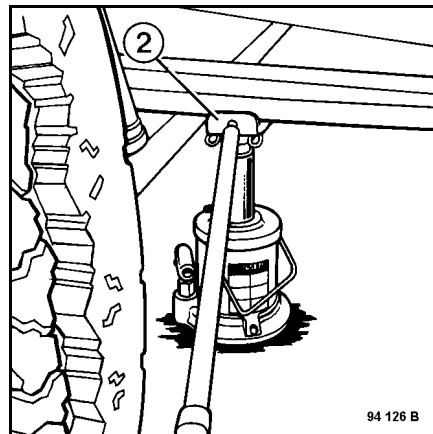

Rear end support points (1)



Chock the front roadwheels.

Air suspension: move the suspension to the "down" position.

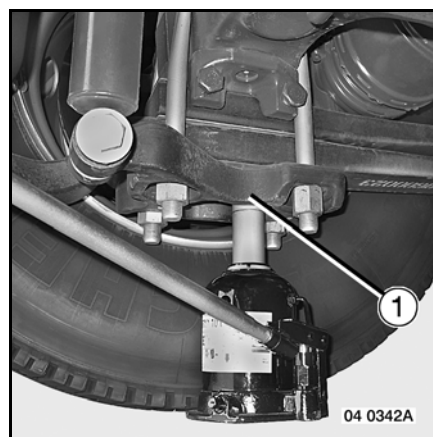

F-6 Quick breakdown repair

Wheel chocks

Top remove the chock (1), undo clip (2). Upon assembly, ensure the correct position for chock (1) and lock the clip (2).

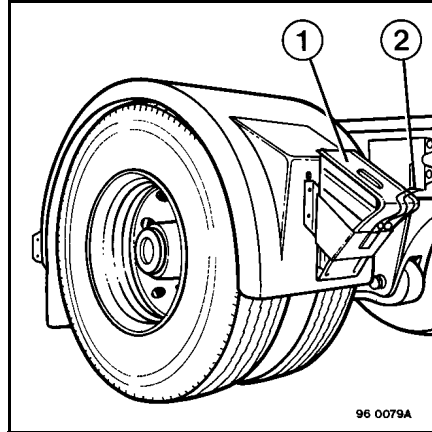

Depending on your vehicle's equipment

To remove wheel chock (1), unhook elastic tightener (2). Upon fitting, ensure that wheel chock (1) is correctly in position and hook up elastic tightener (2).

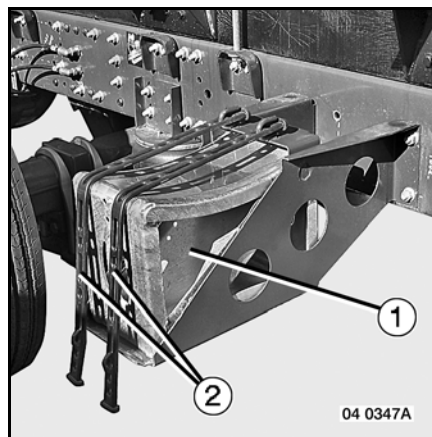
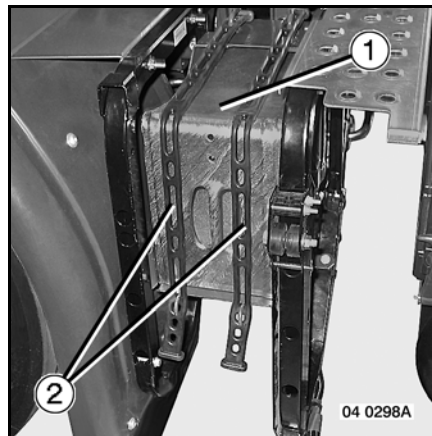

F-7 Quick breakdown repair

Tightening the wheel nuts

Tightening sequence

- Disc wheels

Steel wheels

Wheel nuts tightening torque:
 $200^{\pm 8}$ Nm. + $90^{\pm 10}$ °

Light alloy wheels

Wheel nuts tightening torque:
 $200^{\pm 8}$ Nm. + $90^{\pm 10}$ °.

Wheel nuts tightening torque: at least 670 Nm.

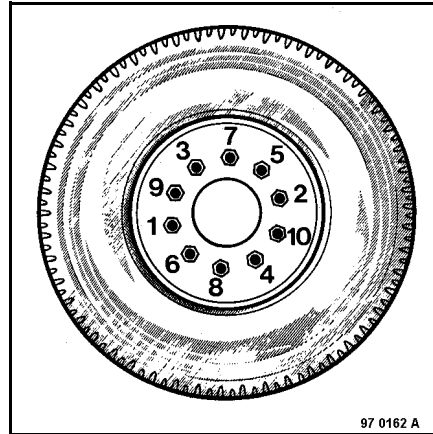

CHECK THE TIGHTNESS OF THE WHEEL NUTS AFTER FITTING A NEW WHEEL OR AFTER A WHEEL CHANGE: AFTER 20 TO 30 KM, THEN BETWEEN 150 AND 250 KM.

CHECK THE TIGHTNESS OF THE WHEEL NUTS EVERY 6 MONTHS WHETHER THE WHEEL HAVE BEEN REMOVED OR NOT.

DURING THE CHECK, IF JUST ONE WHEEL NUT HAS NOT BEEN TIGHTENED TO THE MINIMUM TORQUE OF 670 NM, LOOSEN ALL THE WHEEL NUTS AND RETIGHTEN TO THE RECOMMENDED TORQUE AND ANGLE.

FAILURE TO CARRY OUT THESE ELEMENTARY PRECAUTIONS MAY RESULT IN LOOSENING OF THE WHEEL NUTS AND LEAD TO SERIOUS CONSEQUENCES.

F-8 Quick breakdown repair

Towing

If your vehicle has to be towed, use towing yoke supplied in the vehicle onboard kit. Unclip blanking plug (1) and screw in the yoke.



The yoke attached to the front cross-member is designed for on-road towing under normal conditions. When pulling bogged down vehicles with spinning drive wheels out of mud or loose soil, it is vital to take the customary precautions. Proceed with towing only when the engine is running.

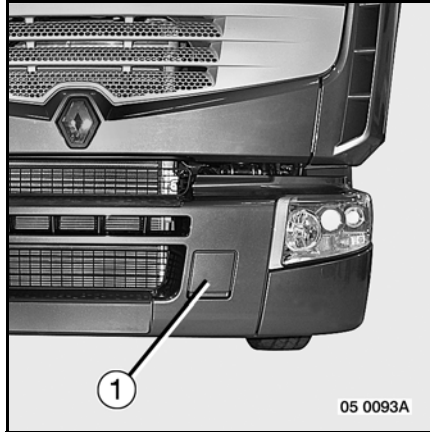

In the event of engine breakdown:

- Mechanically neutralize the brake cylinders if the vehicle has suffered loss of air pressure.
- The steering will be hard to turn as the power assistance system is inoperative.

"4 x 2" type

Put the gear lever into neutral.

- Uncouple the propeller shaft at the drive axle.
- Use the towing yoke.

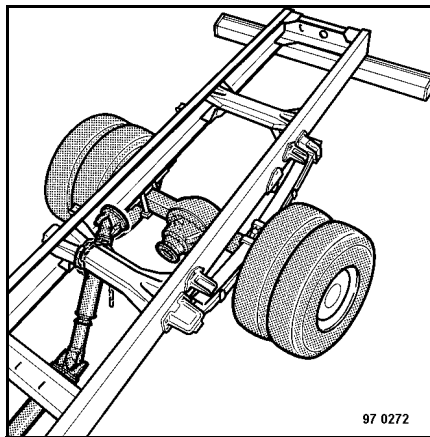

F-9 Quick breakdown repair

Releasing the parking brake

In the event of accidental loss of pressure, proceed as follows to move the vehicle (towing). Using a 24 mm wrench, unscrew bolt (2) on each brake chamber until the roadwheels are free.

Putting back into service: Apply an air pressure of approximately 5 bars to the circuit. Bring the bolt (2) into contact with the cylinder and tighten it at a torque of 75 Nm.

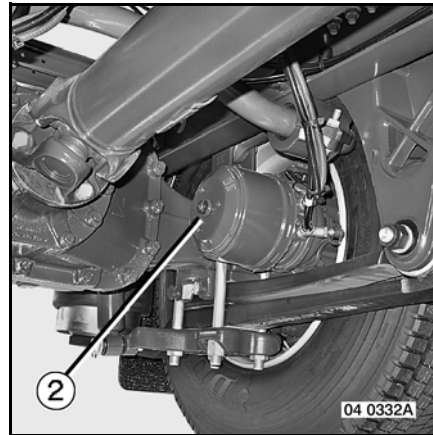

Chock the roadwheels.

F-10 Quick breakdown repair

G-1 Bodybuilder information

Bodywork

It is essential to obtain 1:20th scale chassis drawings from your dealer when fitting bodywork or special equipment (loading crane, fifth wheel, etc...). For the attachment of this bodywork or equipment and also electrical connections, we ask manufacturers and bodybuilders to comply with the RENAULT TRUCKS specifications and standards drawn up for this purpose.

These are readily available from your dealer.

Welding on vehicle



Important precautions to be taken without fail prior to any welding operations

The vehicle is equipped with numerous electronic circuits and numerous ECUs. Prior to carrying out any electric welding work, it is essential to eliminate all potentials by connecting all the ECUs to earth. This can be done quickly by disconnecting the positive (+) cable from the battery terminal and connecting it to earth and then closing the master switch, if fitted. Place the earthing clamp as close as possible to the weld, but never attach it to a rotating part (prop shaft, hub, fan, etc...), nor to any sub-assembly having moving parts (air compressor, turbocharger, etc...). Nearby plastic pipes and electrical cables are to be protected or removed. This also applies for grinding or drilling work. When you reconnect the batteries, When reconnecting the batteries, respect the polarities by always beginning with the positive (+) terminal. If the polarity is reversed, you run the risk of causing irreparable damage to the electronic components.

Supplement to

NE 1/3926 GB

**RENAULT PREMIUM
DXi 11**

Cruise Control/Engine Speed Regulator

50 21 024 392 - 06/2005

english edition

Contents

Chapter

DRIVING.....A

USE OF THE EQUIPMENTB

RENAULT TRUCKS

Société Anonyme au capital de 50 000 000 €
Siège social : 99, route de Lyon
69802 Saint-Priest
Siret 954 506 077 00 120 - RCS LYON B 954 506 077

The manufacturer reserves the right to make any modifications deemed necessary during production. This handbook should not be considered as a specification for the model in question.

© **RENAULT TRUCKS SAS - 2005 - Imprimé en France**

— | | —

Alphabetical index

C

Cruise control, A3-1

E

Engine idling speed adjustment device,
A2-1

F

Fast idling device, A2-2

K

Key to switches, A1-2

P

Power take-off, B1-1

— | | —

— |

| —

— |

| —

A1-1 Driving

A1-2 Driving

Driving position

Key to switches

Dashboard

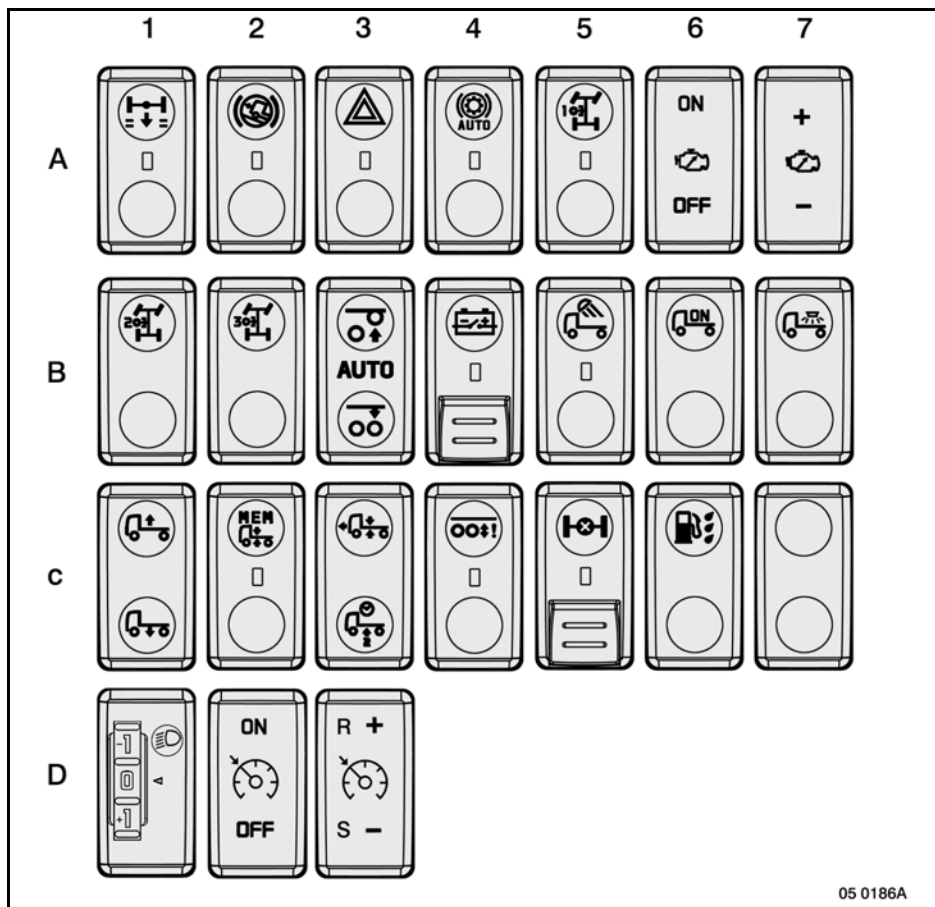

A1-3 **Driving**

Depending on your vehicle's equipment

- A1 - "ASR" control switch
- A2 - Hill-start assist control switch
- A3 - Hazard lights control (see "EBS system" in "Driving" chapter)
- A4 - Retarder control switch (manual / automatic)
- A5 - Power take-off control switch
- A6 - Fast idling ON/OFF control
- A7 - Fast idling engine speed regulator ON/OFF control
- B1 - Additional PTO control switch
- B2 - Engine PTO control
- B3 - Lift-up axle control switch
- B4 - Master switch cut-off control switch (ADR)
- B5 - Working spotlight control switch
- B6 - Bodybuilder's equipment control switch
- B7 - Bodybuilder's lighting control switch
- C1 - Suspension "RAISE / LOWER" control
- C2 - "MEMORIZE / RECALL MEMORIZED SETTING" control
- C3 - "RETURN TO ROAD POSITION / STANDBY" control
- C4 - Axle load-shedding control switch
- C5 - Inter-wheel diff. lock control switch (4x2 - 6x2)
- C6 - Bleed water from fuel control
- C7 - Blanking plug
- D1 - Headlights beam height adjustment control
- D2 - Fast idling/engine speed regulator ON/OFF control
- D3 - Fast idling/engine speed regulator regulation control

A1-4 Driving

Ledge

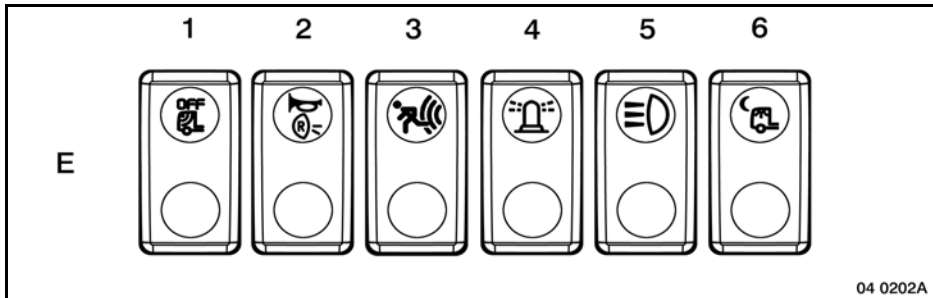

- E1 - Volumetric alarm exclusion control switch
- E2 - Reversing buzzer control switch
- E3 - "PANIC" alarm control switch
- E4 - Revolving beacon switch
- E5 - Extra lights control
- E6 - Red interior lighting control

Engine tunnel console

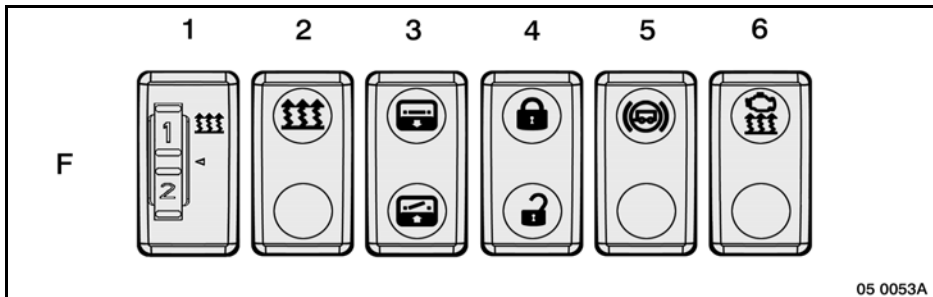

- F1 - Independent heating rheostat
- F2 - Independent heating control switch
- F3 - Sun-roof control switch
- F4 - Central doors locking control switch
- F5 - Trailer brake control switch
- F6 - Air/water independent heating by-pass control

A2-1 Driving

Start-up

Engine idling speed adjustment device

Depending on your vehicle's equipment

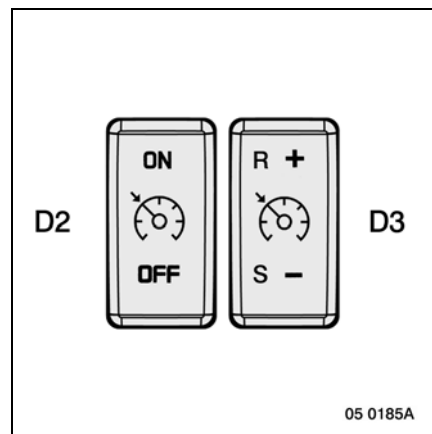
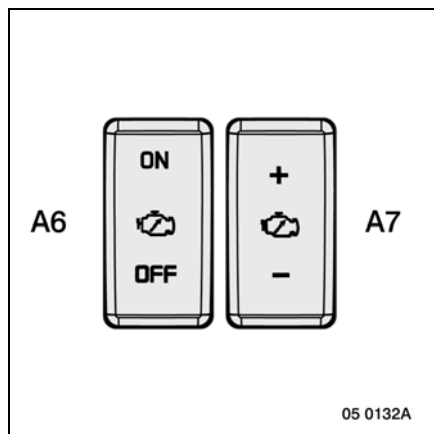

This device serves to adjust the engine idling speed in a band lying between 590 and 650 rpm.

Use

With the vehicle stationary, parking brake engaged, engine idling, move control (A6) - (D2) from "OFF" to "ON" at least 3 times in less than 2 seconds (OFF → ON → OFF → ON → OFF → ON).

With control (A6) - (D2) in the "ON" position, adjust the new engine idling speed:

- press the "+" side of control (A7) - (D3) to increase the engine speed;
- press the "-" side of control (A7) - (D3) to reduce the engine speed.

Once you have defined the engine idling speed, depress the clutch pedal or the brake pedal and release it, to memorize the new engine speed and move control (A6) - (D2) to the "OFF" position to quit the adjustment mode.

A2-2 Driving

Fast idling device

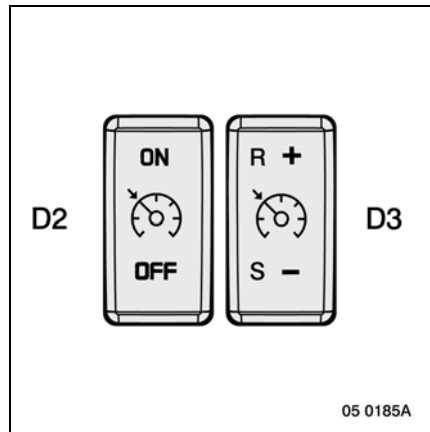
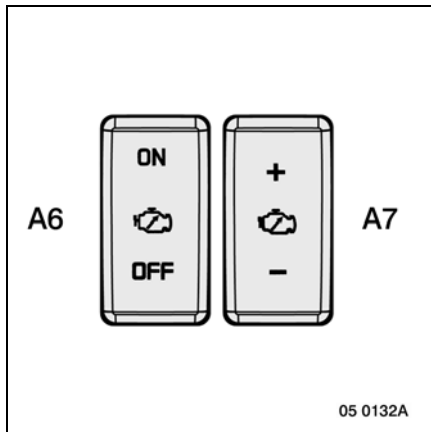

This device serves to control the engine idling speed when the vehicle is stationary.

Use

With the parking brake applied, gearbox in neutral, press the "ON" end of control switch (A6) - (D2). To vary the engine speed, use control switch (A7) - (D3).

Bring the engine to the required speed using the accelerator pedal, and in that position, press the ("-") end of control switch (A7) - (D3) memorize the engine speed.

Release the accelerator pedal.

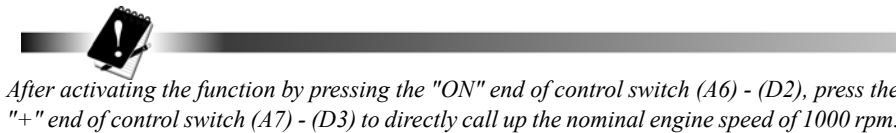

To fine tune the engine speed:

- Press the "+" end of control switch (A7) - (D3) to gradually increase the engine speed.
Or dab the "+" end of control switch (A7) - (D3) to increase the engine speed in increments.
- Press the "-" end of control switch (A7) - (D3) to gradually reduce the engine speed.
Or dab the "-" end of control switch (A7) - (D3) to reduce the engine speed in decrements.

Any action on the brake pedal, any gear changing or any pressing of the "OFF" end of control switch (A6) - (D2) overrides the function.

A2-3 **Driving**

Vehicle equipped with PTO(s)

When at least one PTO is in operation, the first action on control switch (A7) - (D3) calls up the engine speed preset in the works (1000 rpm).

This engine speed can be adjusted but is limited to 1500 rpm (see "Power take-off" in the "Use of the equipment" chapter).

Depending on the equipment fitted by the equipment manufacturer, the input conditions for this engine speed can be modified using the RENAULT TRUCKS test tool.



Avoid touching the accelerator pedal during use of the fast idling feature.

A2-4 **Driving**

A3-1 Driving

On the road

Cruise control



Above a speed of 30 km/h, this feature serves to travel at a steady speed without using the accelerator pedal.

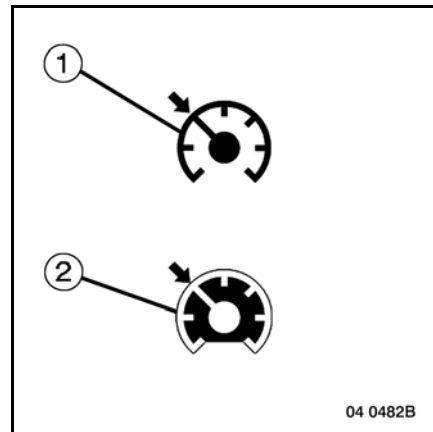

If your vehicle is equipped with a retarder control with 2 to 5 setting positions.

When travelling downhill, the cruise control automatically pilots the different retarders in order to maintain the memorized speed.

A blue sector appears in zone (T) of the engine rev counter (V) to indicate the engine speed at which efficiency of the retarder(s) is optimal. Warning pictogram (1) or (2) also appears depending on the background colour selected for the information display (L).

If the retarders cannot maintain the set-point speed, the memorized speed flashes - use of the brakes is necessary.

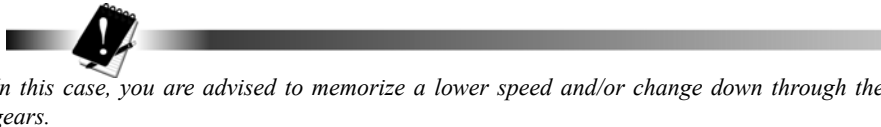

Use

- Bring the vehicle to the desired road speed, using accelerator pedal, retarder control or service brake.

A3-2 Driving



Upon activation of the cruise control or adjustment of the set-point speed, the information is displayed in large format in the main zone (2) of the information display. It is then displayed in zone (4) of the information display when the retarder is active ("ON").

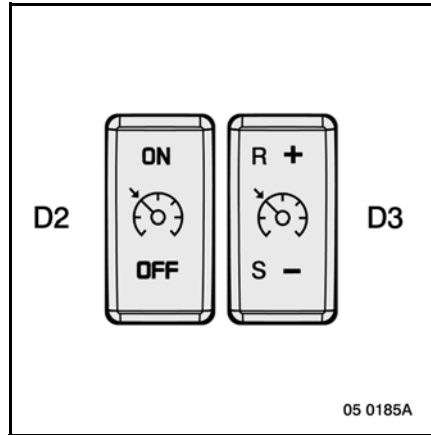

- Press the "ON" control on switch (D2).
The memorized speed (3) is displayed (by default, - - km/h).
- Press the "S-" end of the control switch to memorize the speed.

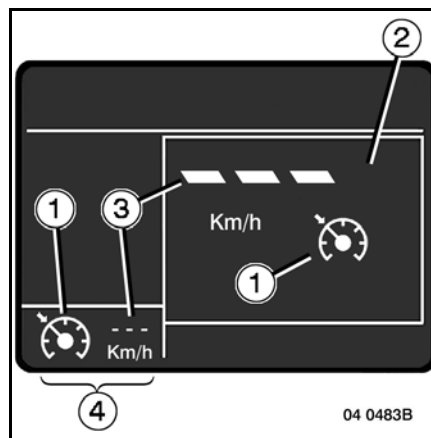

A3-3 Driving

To adjust your cruising speed:

- Press the "R+" end of the control switch to increase the speed.
- Press the "S-" end of the control switch to reduce the speed.
- A dab on the switch modifies the speed by 1 km/h.

Keeping the "R+" end of the switch pressed varies the speed until the switch is released.

Keeping the "S-" end of the switch pressed activates the retarders so as to slow the vehicle down faster.

At any moment, any action on the accelerator pedal serves to momentarily overstep the set speed.

Any action on the clutch pedal momentarily overrides the feature. Release the clutch pedal and the cruise control feature resumes automatically.

The feature is cancelled, pictogram (G39), item (1) disappears. the memorized speed remains displayed if:

- The road speed is below 15 km/h;
- You actuate the brake pedal or the retarder control, except on downhill sections, if the road speed remains less than 2 km/h higher than the cruise control speed.

In the event of slowing down to within ± 2 km/h of the memorized speed, pictogram (G39) flashes.

To return to the memorized road speed, press control "R+".

Pressing the "OFF" control on switch (D2) cancels the function.



The cruise control is not a speed limiter and cannot be used as such.

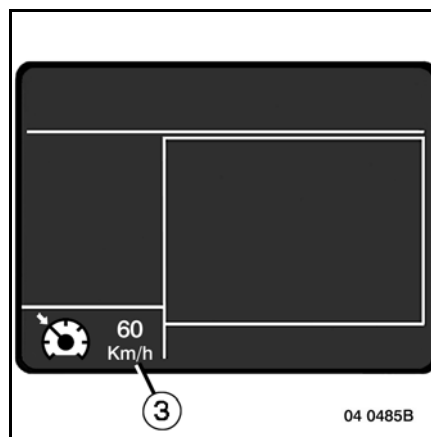
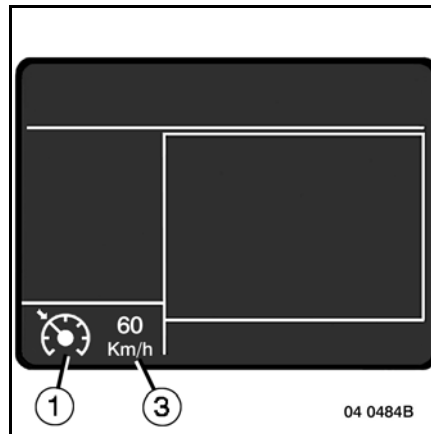
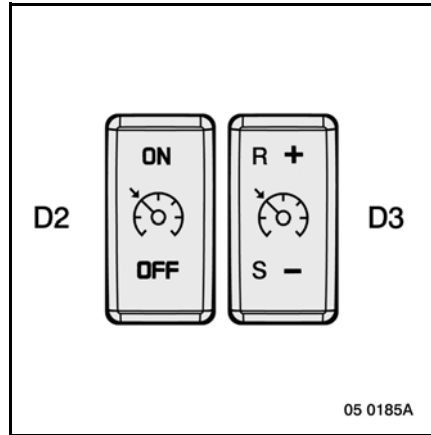

A3-4 Driving

B1-1 Use of the equipment

Trade equipment

Power take-off

Depending on your vehicle's equipment

Power take-offs mounted on gearbox

Optidriver 2

Two possible uses
(when stationary or while moving)

Use while stationary

- Engine speed < 700 rpm.
- Ring (2) on selector (1) in position "N"
(gearbox in neutral).
- Parking brake and/or service brake
applied.
- Zero road speed.

Press PTO control switch (A5) until pictogram
(G41) is displayed.

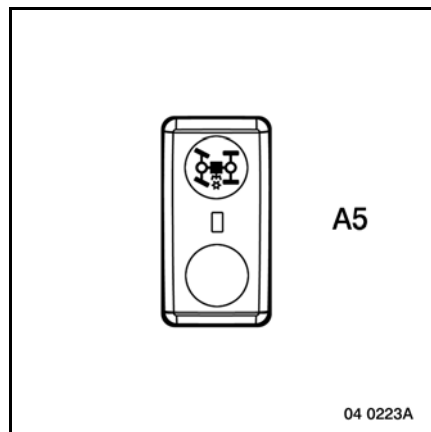
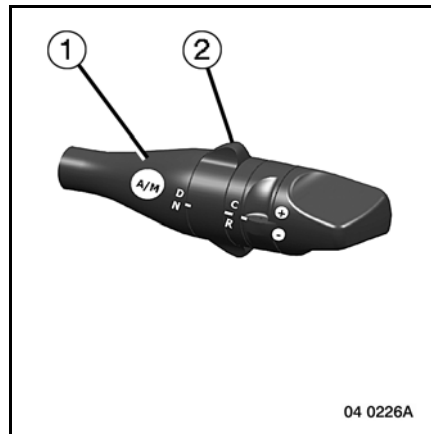

B1-2 Use of the equipment

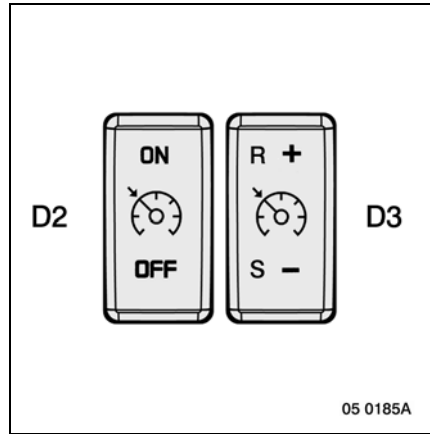
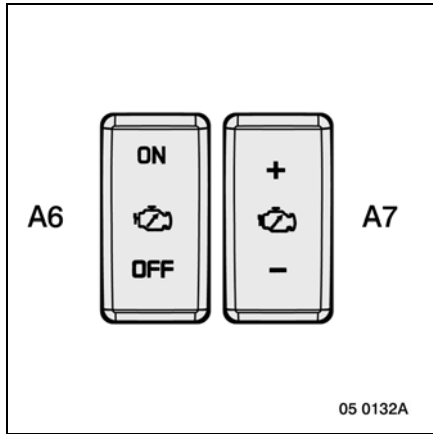

Once the PTO is engaged, adjust the engine speed:

- Move toggle switch (A6) - (D2) to the "ON" position.
- Adjust the engine speed with toggle switch (A7) - (D3).

The symbol "N" and pictograms (G42 - G43) are displayed.

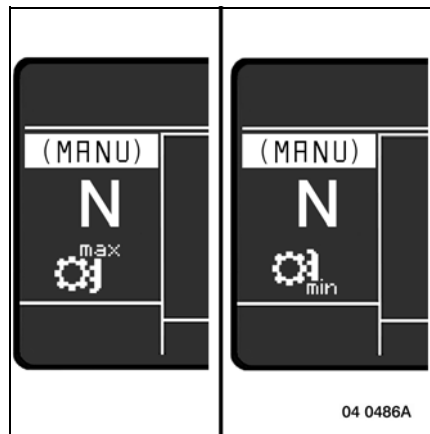
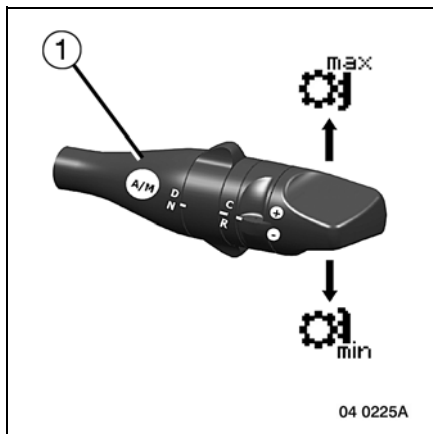

Two operating speeds for the power take-off

When the vehicle is stationary, select the "min." or "max." speed by moving the selector (1):

- forwards, parallel with the steering wheel, to the (+) "max." speed position.
- rearwards, parallel with the steering wheel, to the (-) "min." speed position.

B1-3 Use of the equipment

Use when the vehicle is moving



Feature to be enabled by dealer or by bodybuilder using the RENAULT TRUCKS bodybuilder test tool

The power take-off is engaged while the vehicle is stationary.

- Engine speed < 700 rpm.
- Parking brake and/or service brake applied.
- Zero road speed.
- Ring (2) on selector (1) in position "N".
- Press PTO control switch (A5). Pictogram (G41) and "PTO engagement" are displayed.



To facilitate engagement of the PTO, release the service brake and gently depress the accelerator pedal.

- The PTO is engaged, pictograms (G41 - G42) or (G41 - G43) appear on the information display.
- Release PTO control switch (A5).
- With the vehicle stationary, select the moving away gear suitable for such use (only the first 6 gears are possible).



- *The rotating speed of the PTO depends on the gear engaged:
1st, 3rd or 5th gear: PTO minimum speed.
2nd, 4th or 6th gear: PTO maximum speed.*

- Depress the accelerator pedal to move the vehicle away: the PTO begins to rotate.



Gear changing is no longer possible.



When using the PTO while the vehicle is moving, the cruise control / engine speed regulator will be inoperative for safety reasons. The engine speed is to be modified by using the accelerator pedal.

B1-4 Use of the equipment

Disengagement of the PTO

The PTO is disengaged:

- by pressing switch (A5),
- if the selector is moved back to the neutral position (ring (2) in position "N"),
- if the engine stalls.

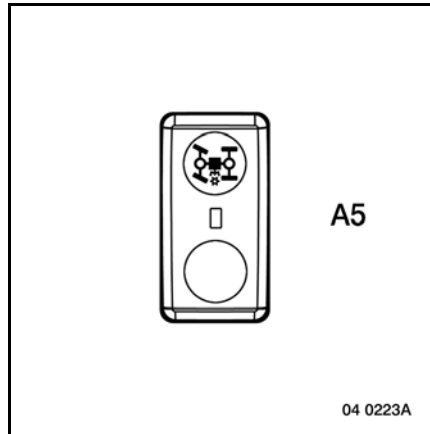

 Certain PTO engagement / disengagement and engine speed regulation conditions can be adjusted using the RENAULT TRUCKS bodybuilders software.

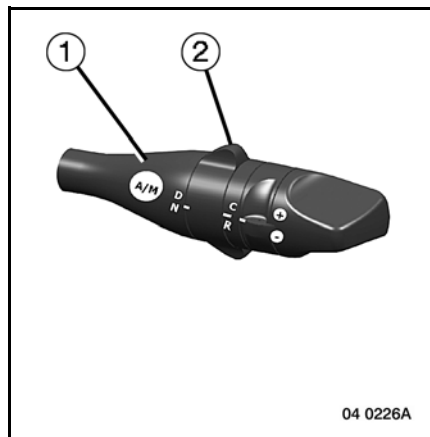

PTO rotating speed

For an engine speed of 1000 rpm.

Front splitter in low speed range (PTO minimum speed):

gearbox neutral, 1st, 3rd or 5th gear.

- Hydrocar 81: 705 rpm.
- Hydrocar 84: 910 rpm.

Front splitter in high speed range (PTO maximum speed):

gearbox neutral, 2nd, 4th or 6th gear.

- Hydrocar 81: 897 rpm.
- Hydrocar 84: 1159 rpm.