

**SUNBA**<sup>®</sup>

# Illuminati Auto Tracking Network PTZ Camera

User Manual 1.0

2019/11

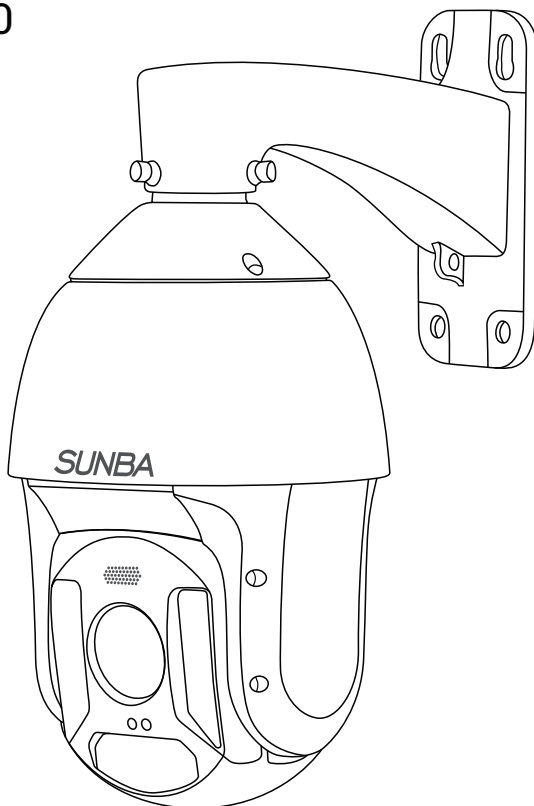

Visit <http://autotrack.sunba.net> to access the step by step YouTube video tutorials for setting up Sunba Illuminati.

# FCC Warning (U.S.A)

The device has been tested in compliance with limits set by Part 15 of Federal Communication Commission (Class B). The operation of the device is thus limited by the following two conditions:

1) it is not permitted to cause harmful interference to any authorized radio communications, and 2) it must accept any interference it receives.



WARNING: Please test the camera locally by directly connecting to the default power adapter from the package before mounting it outside. Stay at least 24 hours to test both daytime and night vision IR LED.

## MENU

1. Model Specification	01
2. Connection and Installation	01
3. Camera Management	05
3.1 Web Interface	05
3.2 Client Software	06
3.3 Smartphone app	10
4. Static IP Management	13
5. PTZ, Preset and Patrol	13
6. The Full Preset List	15
7. Auto Tracking	16
8. Remote Access	22
9. User Management	25
10. Motion Detection	26
11. FTP Communication	28
12. Cable Waterproof Measures	29
13. ONVIF Integration	30
14. Smartphone Push Notification	31
15. On-Screen-Display	32
16. Reset the Camera	34
17. Warranty	38

# 1. Model Specification

Model	Illuminati
Image Sensor	1/2.8" Progressive SONY CMOS
Resolution	50HZ: 25fps (1920×1080) 60HZ: 30fps (1920×1080) 50HZ: 25fps (1280×720) 60HZ: 30fps (1280×720)
Focal Length	4.8 ~120mm
Angle of View	57.6 ~ 2.5 Degrees (Wide-angle ~ Telescope)
Aperture Range	F1.6 ~ F3.5
Min. Illumination	Color: 0.05Lux@(F1.6, AGC ON) B/W: 0.01Lux@(F1.6, AGC ON)
Focus	Auto/Manual/Semi-auto
Pan & Tilt	Pan: 0 ~ 360° Tilt: -15 ~ 90°
Zoom	Optical: 25X Digital: 16X
Day/Night Mode	BW/Color/Auto
Night Vision	Up to 1000ft
Standard	TCP/IP, HTTP, DHCP, DNS, DDNS, RTP, RTSP, PPPoE, SMTP, NTP, UPnP, SNMP, FTP, 802.1x, QoS, HTTPS, IPv6 (SIP/SRTP)
API Interface	ONVIF/ISAPI/SDK
Auto Tracking	Preset Tracking, Intrusion Tracking, Line Cross Tracking
Audio	G.722.1, G.711-a law, G.711-u law, MP2L2, G.726, AAC, PCM

## 2. Connection and Installation

### 2.1 Indoor Bench Test

Please test the camera properly on the bench for 24/7 before install it outside. The pre-installing test is so critical to ensure all equipments will work as expected. This will test network and power transmission, monitor day and night video quality, and avoid any potential issues that might develop when the camera is finally mounted.

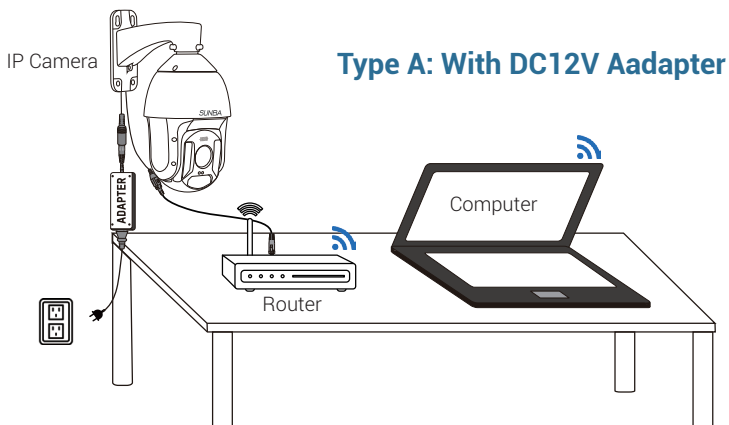



Test the camera on your desk before mounting outside.

Do NOT extend the power cable during the bench test because DC power drops quickly along the transmission. A bench test helps you rule out all problems caused by power supply. Underpower causes problems such as

- 1. Ghost image**
- 2. Unstable infrared (camera reboots repeatedly) and**
- 3. Random spinning dome.**

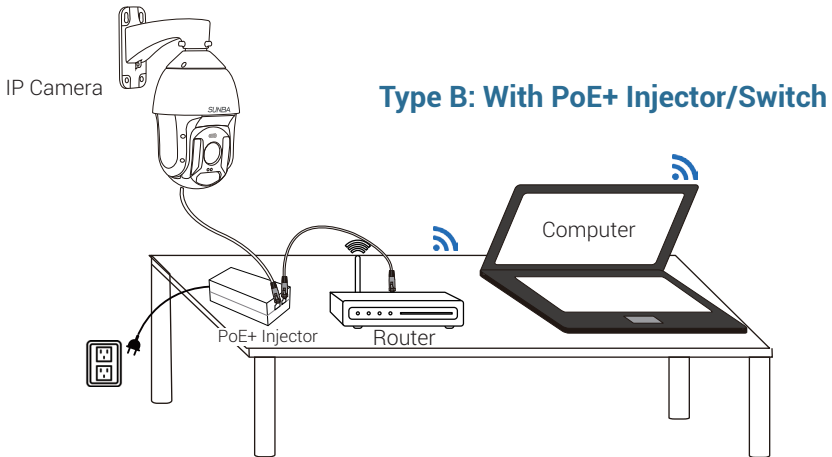

### Built-in self-test

When powered up, the speed dome automatically begins a self-diagnostic process during which the camera will pan horizontally and vertically to make sure PTZ, lens and other parts of the camera are functional. Please contact our technical staff if a self-test does not happen on your unit. Please refrain from disassembling the unit before contacting us. Thanks for your cooperation.



- ✓ Connection Good
- ✓ Power Good
- ✓ Video and Control Good
- ✓ Tested Day and Night
- ✓ Guess we are ready to mount it outside.

Questions? Ask [support@sunba.net](mailto:support@sunba.net)

## 2.2 PoE+ Requirement

PoE+IEEE 802.3at standard is required. Note traditional PoE system( 802.3af standard) delivers up to 15.4W, which is unable to fully support the camera. Dome cameras, especially with 20x zoom-in capacity, have higher power requirements than fixed cameras.

### Transmission distance

PoE will also drop power along the Ethernet cable. With PoE+ adapter supplying 30W, please don't run Ethernet over 200ft. The maximum travel distance depends on the quality of the cable and the maximum power supplied by switch/injector.

### NVR's built-in PoE switch

Some NVRs have built-in PoE switches. It is important to check whether each port can supply at least 25W (with 802.3at) as some of those are for bullet cameras and can't supply enough power for PTZ (with 802.3af only).

### Biggest issue when underpower

In the daytime, even 802.3af (conventional PoE system) can provide enough power to the camera. However, in the night time, if you are underpower, the following problem begins: low light environment detected -> infrared on -> not enough power -> reboot -> low light environment detected -> infrared on -> not enough power -> reboot ..... (cycling)

## 2.3 Install the TF Card

Illuminati camera comes with a built-in micro SD card slot that can store videos and snapshots.

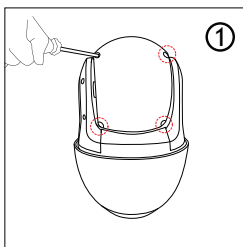

Remove the 4 screws to take off the camera back cover.

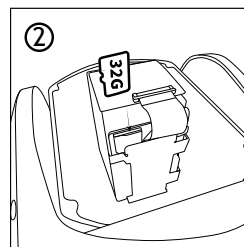

Insert the TF card as directed by the arrow.

## 2.4 Mounting Outdoor



Good, the camera is working correctly. Now I just need to pick the right extension cable and mount it outside!

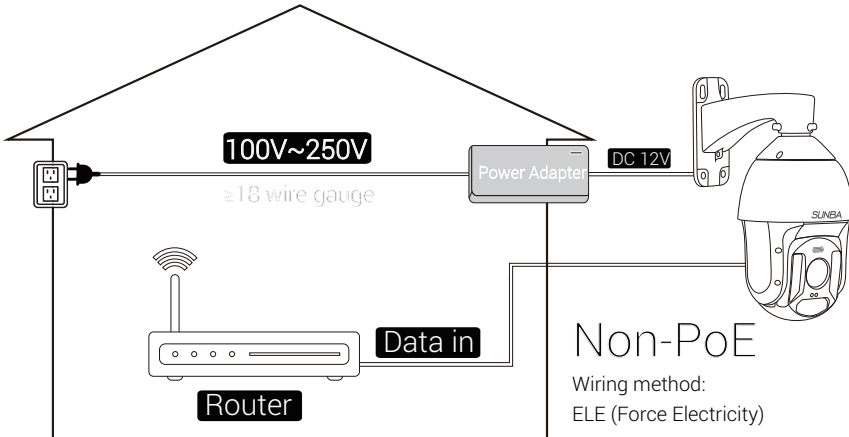
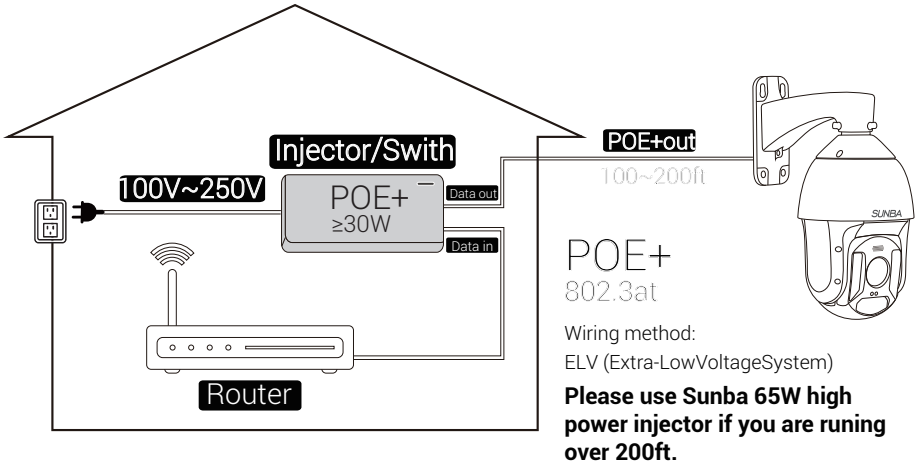

Consider using extension cord to get AC the required distance first, then use the power adapter. If that's not possible in your environment, pick a thicker wire ( $\geq 18$  AWG) for DC extension or consider running PoE+.

The screws and anchors to attach the camera to the installation environment are not included and please set the appropriate screws subject to the specific environment such as concrete, wood, dry wall and bricks.

# 3. Camera Management

The camera is set to DHCP mode by default, meaning the router will automatically assign a matching IP to the camera. Therefore, the camera should be in “online” status once it has been powered and connected to the router.

Default Username/Password:

Username: admin

Password: **Admin12345**

**Note:** Please pay attention to the capitalized A in the password field.

## 3.1 Camera Management by Web

The following browsers are supported:

Internet Explorer 11 (Windows)

Chrome (Windows)

Firefox (Windows)

The first step of accessing the camera via a web browser is to obtain its IP, which is the url of the camera. **The IP scanning tool called SADP is required to be installed first.**

The SADP tool (Mac & Windows) can be retrieved from the CD-ROM or from Sunba website (under download section: <https://sunbatech.com/download/>)

Below is a screenshot of the tool and the “IPv4 Address” column stands for the IP of the camera.

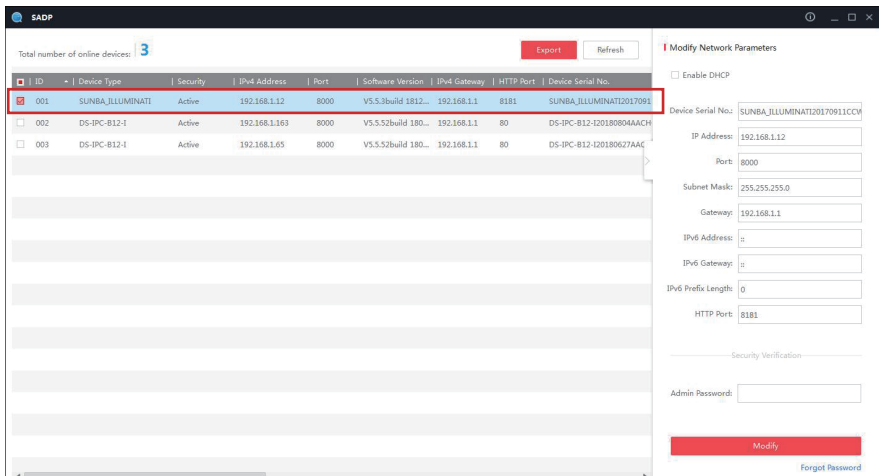

Next, please open a compatible web browser, and input the IP of the camera in the address line. For example, for the above camera, please enter `http://192.168.1.12` in the address line. In the future, if the default HTTP port (80) of the camera has been changed, the url to login the camera through web interface will be `http://IP:HTTP Port`

A web plugin must be installed manually for all browsers. The plugin file can be obtained from Sunba website or from the CD-ROM came with the camera.

In the login page, please input the default username/password of the camera:



Click “Login” to log into the camera.

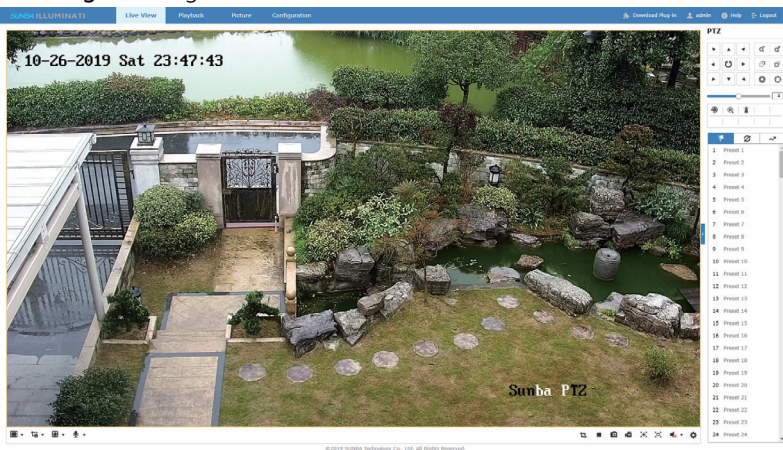

### 3.2 Camera Management by Client Software

Windows: iFollow

Mac: Guarding Vision

The software set can be retrieved from the CD-ROM or from Sunba website (under download section: <https://sunbatech.com/download/>)

Install and open the software, which will ask you to assign a user for the iFollow client. Note this is **NOT** the credential for the camera. The purpose of creating an account for iFollow client is to avoid unauthorized access to the surveillance monitor software. Users can also “**enable auto-login**” to skip the authentication step every time the software is open.



The 'Register Administrator' dialog box contains the following text and fields:

Please create a super user for the Sunba iFollow Client to avoid unauthorized access to the surveillance monitor software.

Super User: [text input field]

Password: [password input field]

Confirm Password: [password input field]

Enable Auto-login

Buttons: Register, Cancel

Next, the client will display all discoverable online device and please select a device, and click “**Add to Client**” to add the camera to the Device for Management.

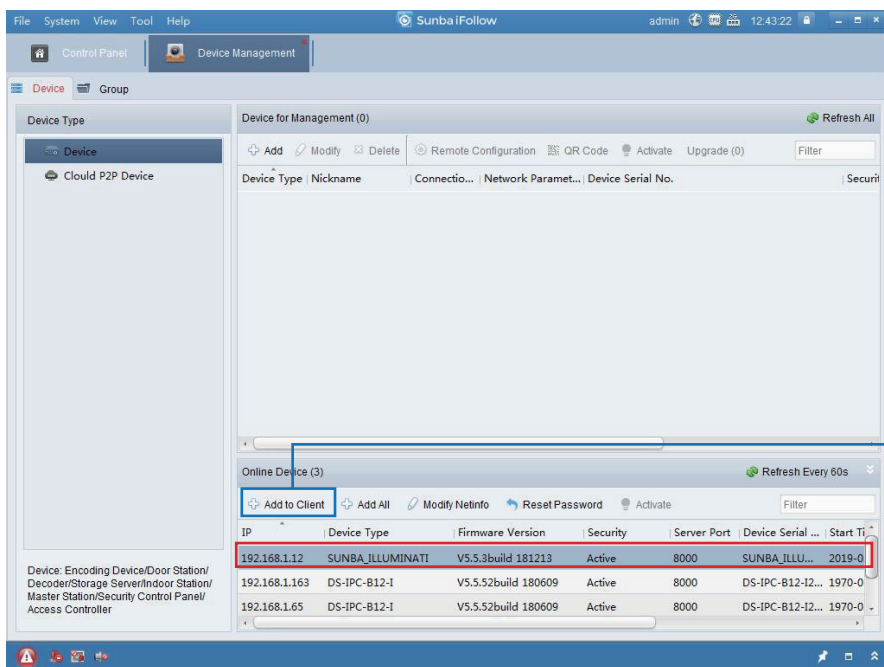

The Sunba iFollow software interface shows the 'Device Management' tab. It features a 'Device for Management (0)' section and an 'Online Device (3)' section. The 'Online Device (3)' section contains a table with the following data:

IP	Device Type	Firmware Version	Security	Server Port	Device Serial ...	Start Ti
192.168.1.12	SUNBA_ILLUMINATI	V5.5.3build 181213	Active	8000	SUNBA_ILLU...	2019-0
192.168.1.163	DS-IPC-B12-I	V5.5.52build 180609	Active	8000	DS-IPC-B12-12...	1970-0
192.168.1.65	DS-IPC-B12-I	V5.5.52build 180609	Active	8000	DS-IPC-B12-12...	1970-0

Users can customize a nickname for the device, enter its username/password and choose whether to “**Synchronize the Device Time**” to the desktop.

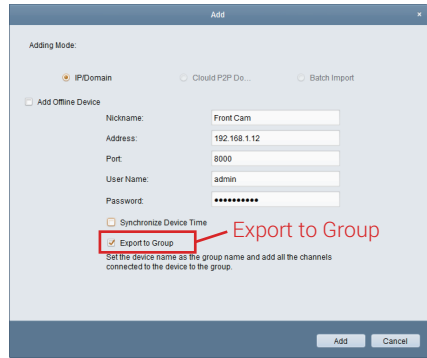
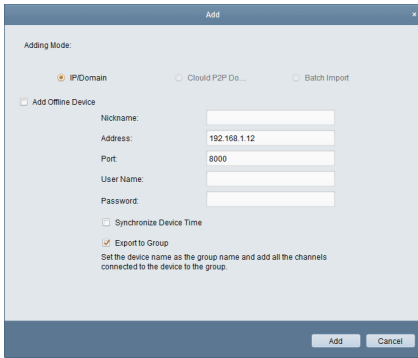

Please remember to click **“Export to Group”**, which is a required step before users are able to view and configure the camera over the client software. The purpose of **“Group”** is to better categorize different cameras in a surveillance project.

If the **“Export to Group”** option is not selected when the camera has been initially added, users can go to **“Group”** and click **“Import”** to manually assign the camera to a group.

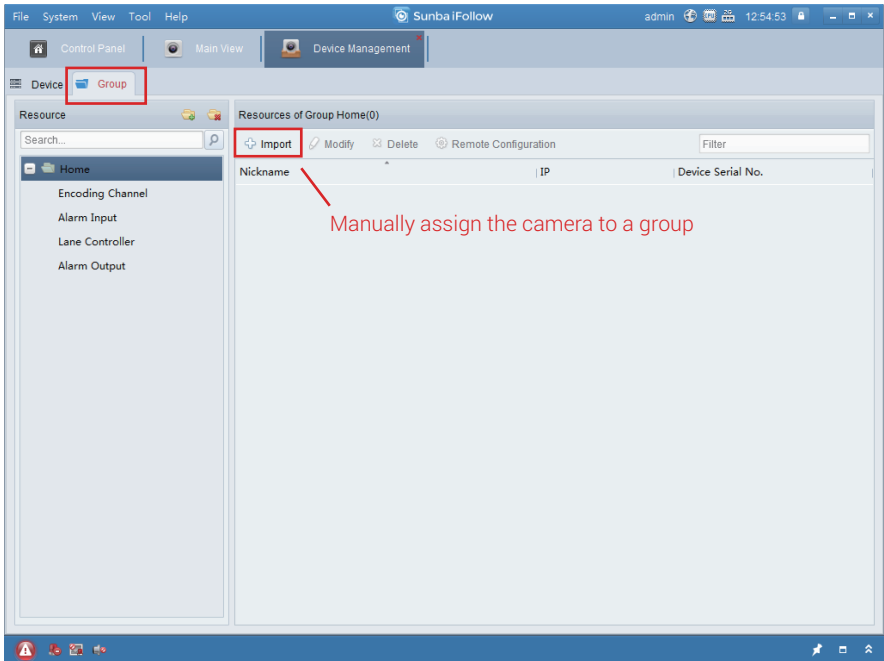

In the Import menu, select the camera on the left hand side, and create a group folder on the right hand side such as **“Home”**, **“Office”** or **“Sunba”** by the characteristics of cameras for categorizing purpose.

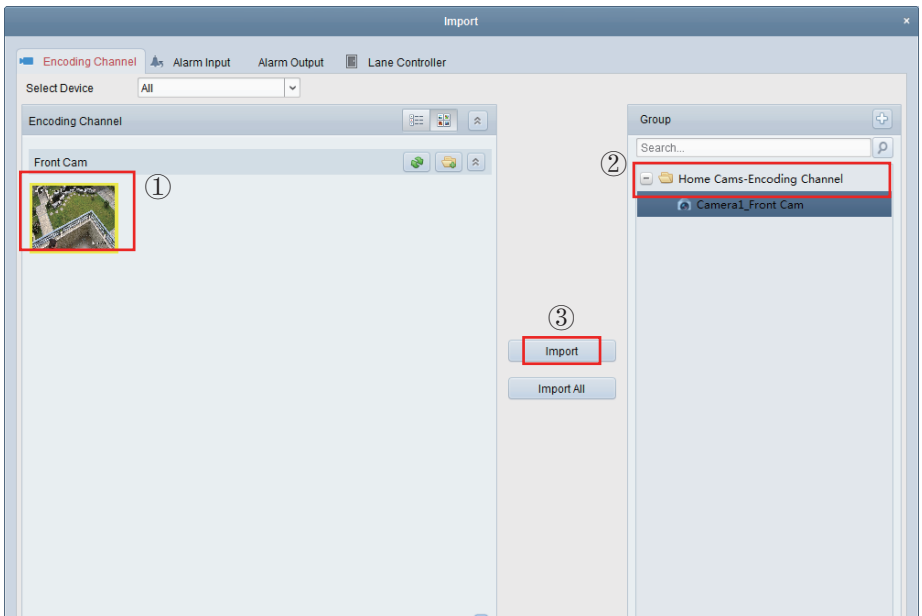

Click **"Import"** to import the camera to the specified group.

Next, please go to the **Main View** page and double click the camera to start live view.

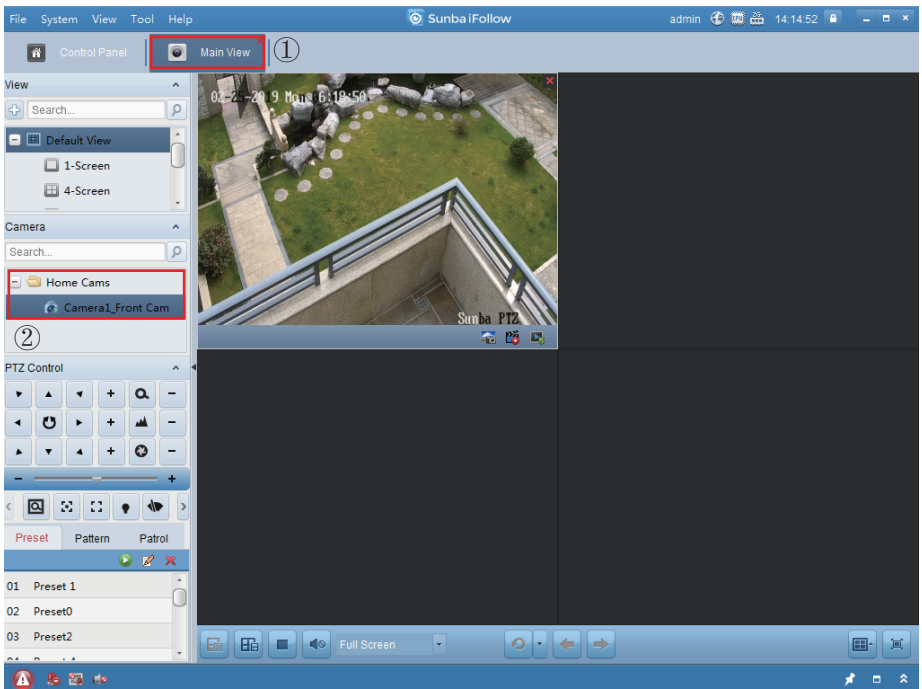

### 3.3 Camera Management by Smartphone App

#### IOS & Android: **Guarding Vision**

Step 1. Select Country and Region.

Please note the regions cannot be changed once your account has been created.

Step 2. Create a cloud account and login. You can authenticate the account through either phone number or email address.

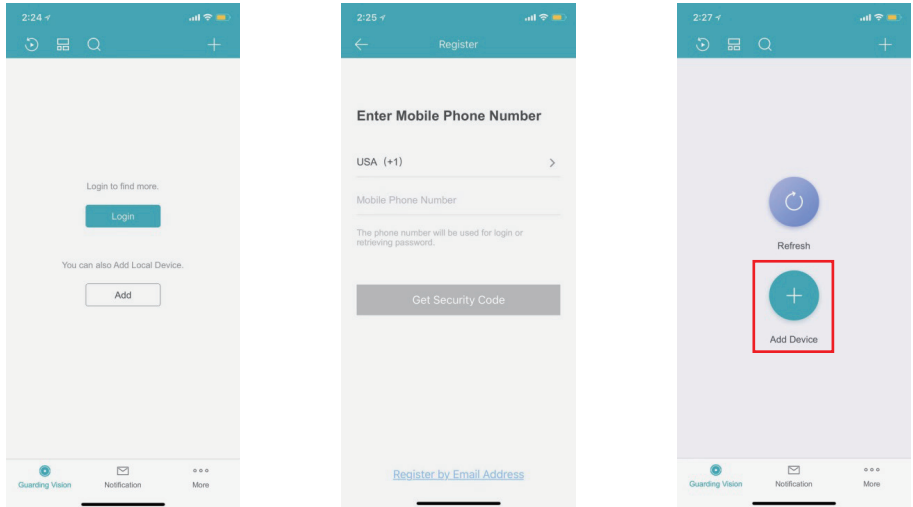

Step 3. Add a Verification Code

In **Configuration>Network>Advanced Settings>Platform Access**, the cloud platform status must be "Enable" and the status must be "Online" before the P2P service works. A verification code must be added as well to verify the connection on your smartphone account as well.

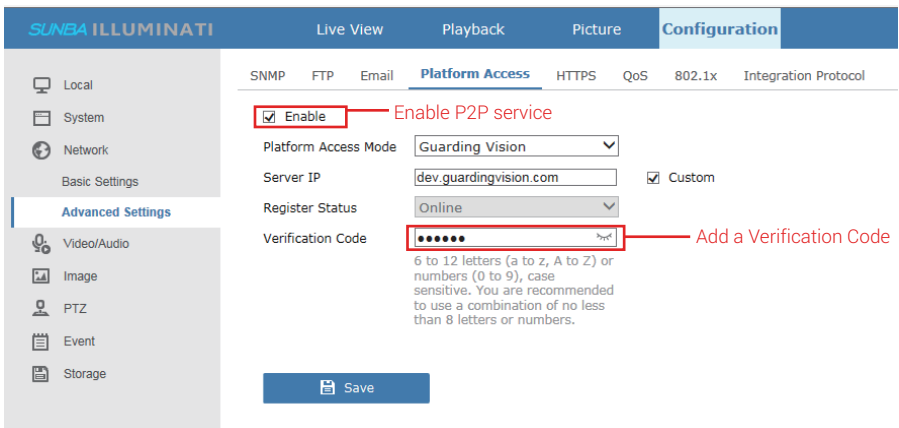

#### Step 4. Add Device

Tap “Add Device” to scan the QR barcode on the silver label of the camera body, or tap the “+” icon on the top right corner to manually enter the camera serial number. The serial number can be found from the silver label. Alternatively, you can find the serial number from the SADP tool, Web Interface or the iFollow client.

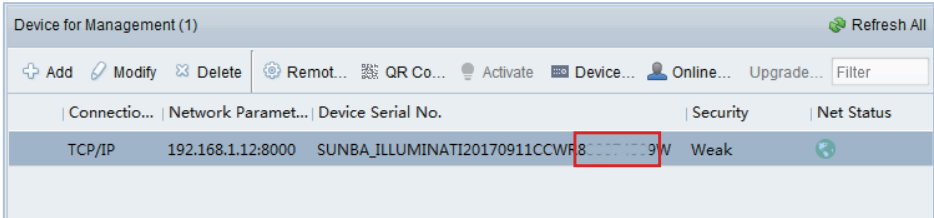

Connectio...	Network Paramet...	Device Serial No.	Security	Net Status
TCP/IP	192.168.1.12:8000	SUNBA_ILLUMINATI20170911CCWR8[redacted]9W	Weak	

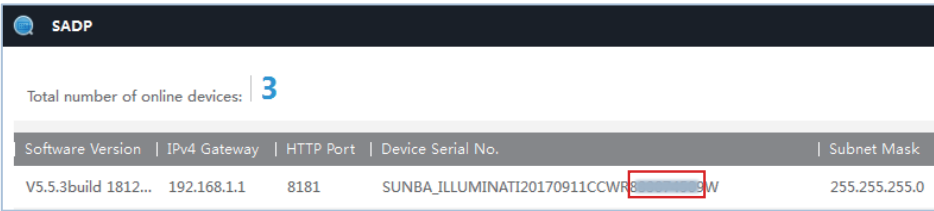

Total number of online devices: **3**

Software Version	IPv4 Gateway	HTTP Port	Device Serial No.	Subnet Mask
V5.5.3build 1812...	192.168.1.1	8181	SUNBA_ILLUMINATI20170911CCWR[redacted]9W	255.255.255.0

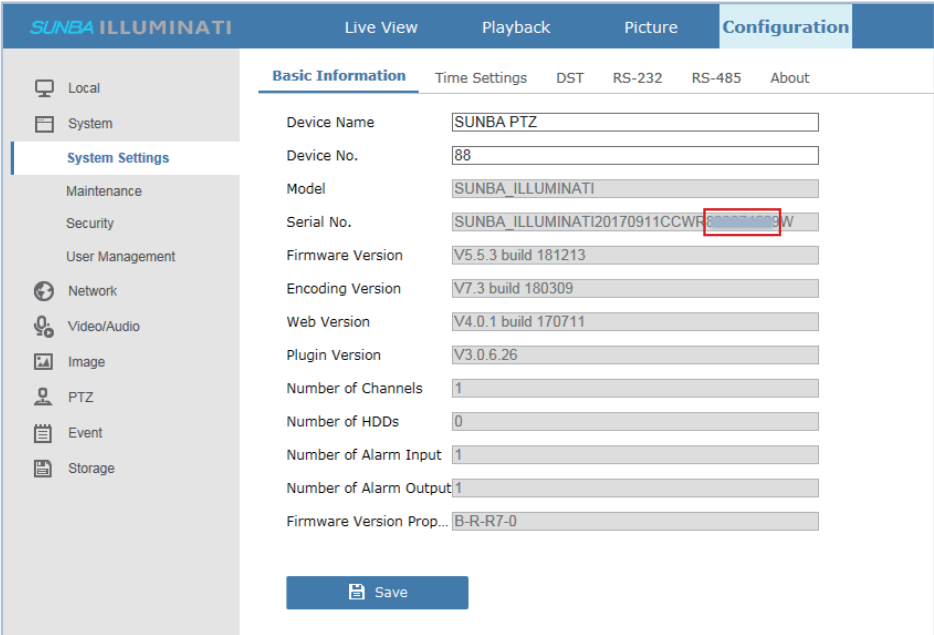

**SUNBA ILLUMINATI**      Live View      Playback      Picture      **Configuration**

Local      System

**System Settings**

- Maintenance
- Security
- User Management
- Network
- Video/Audio
- Image
- PTZ
- Event
- Storage

**Basic Information**      Time Settings      DST      RS-232      RS-485      About

Device Name:

Device No.:

Model:

Serial No.:

Firmware Version:

Encoding Version:

Web Version:

Plugin Version:

Number of Channels:

Number of HDDs:

Number of Alarm Input:

Number of Alarm Output:

Firmware Version Prop...:

**The numeric values between WR and W represent the serial number.**

### Step 5. Live View

The app may ask you to enter the verification code (see step 3) before you are able to watch live view. If the verification code fails, try modifying another code in the web interface and click “Save” to refresh the code. Tap the device name under “My Device” to start live viewing.

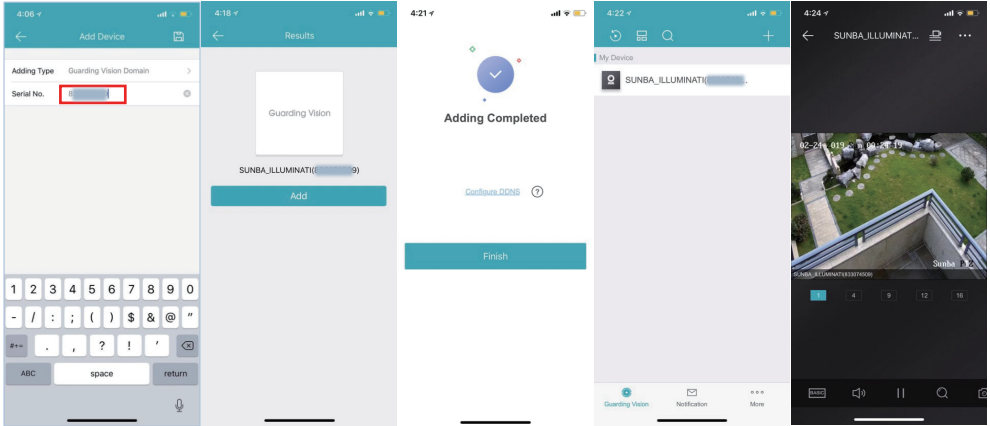

### Step 6. Control pan tilt zoom and preset.

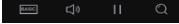
Apart from live viewing, users can control pan tilt zoom and preset through the app. Browse the toolbar  at the bottom and tap the pan tilt zoom icon to open the page below.

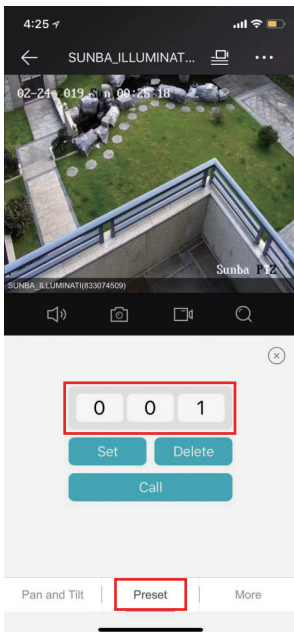

Tap “Preset” to the preset config page to set, call and delete a preset. Please refer to Chapter 5, 6 and 7 to learn more about setting up a preset and enabling auto tracking.

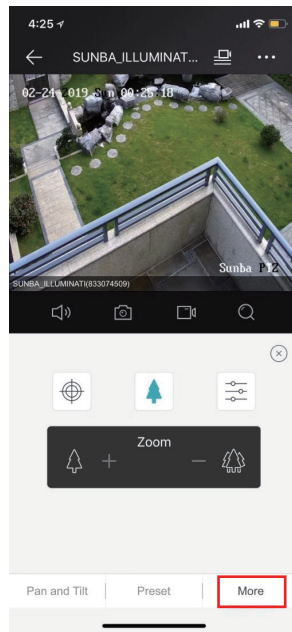

Tap “More” and select the tree icon to access/control the zoom toolbar.

# 4. Static IP Management

To assign a static IP to the camera, please go to **Configuration-Network-Basic Setting-TCP/IP** and unselect DHCP. Then manually modify the camera IP and click “Save”.

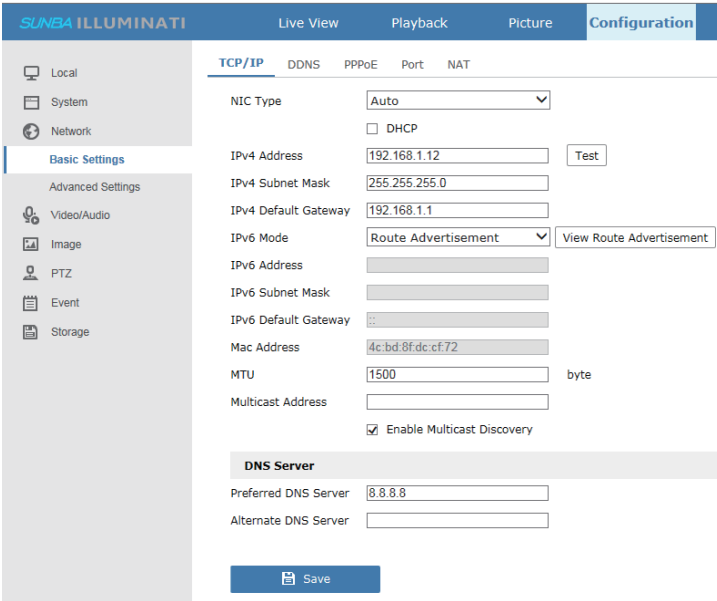

In the rare cases that IP conflicts, the router may manually assign another static IP to the camera. Therefore, it is also recommended to configure a Mac-IP reservation through the router as well.

# 5. PTZ, Preset and Patrol

## PTZ Preset Position

Sunba dome cameras can set preset PTZ positions for which cameras can memorize and travel directly by calling the preset. Preset positions are represented by numbers. You need to “add” a preset and then “call” it. You can always “delete” them later.

Find the preset number and hit “⚙️” to set/add/save a position preset.

Find the preset number and hit “➡️” to call a position preset.

Find the preset number and hit “✖️” to delete a position preset.

In the web interface, users can double click the preset name on the list to customize the name for the position preset such as front gate, back yard or parking lot.



### Special Presets

Special presets are preset numbers associated with advanced commands that cameras can follow to enable settings such as changing infrared LED night vision mode, setting up auto tracking etc. You can call the preset directly (no need to “add” a preset as they are pre-existed) according to

#### The Full Preset List.

Note: You cannot delete any special preset.

### Patrol

The PTZ camera can travel from one preset to another by order. A patrol is usually named as a tour or a cruise. The total presets included in a patrol can be up to 10. To activate a patrol, first you will need to save corresponding presets you want to tour across. For example, a tour from preset 1 to preset 10 can be activated by calling special preset 88 (see **The Full Preset List**).

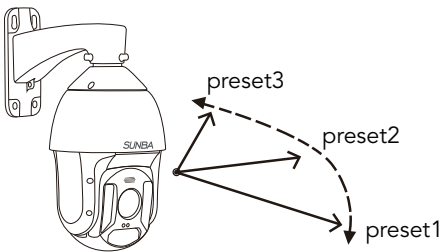

Note: When executing any PTZ related commands including calling a preset and pressing PTZ direction key, the camera will stop patrolling.

### Tracking Presets

Tracking presets are a mixture of position preset and special preset. More details can be found in **Chapter 7. Auto Tracking**.

**[Preset Tracking]** Preset tracking requires you to set a position preset (53-59) first, and call it to activate the preset tracking. The camera will follow any moving object in this pre-defined position.

**[Intrusion Tracking]** User needs to set a home position (preset 50) for the intrusion event, and call preset 50 to activate intrusion tracking. The camera will return back to preset 50 when tracking completes.

**[Line Cross Tracking]** User needs to set a home position (preset 51) for the line cross event, and call preset 51 to activate line cross tracking. The camera will return back to preset 51 when tracking completes

# 6. The Preset List

Preset No.	Name	Set	Call	Delete	Park Act	Note
1-49	Position Presets	Yes	Yes	Yes		Only preset 1-32 support Park Act.
50	Intrusion Tracking	Yes	Yes	Yes	Yes	A surveillance scene (preset 50) and an intrusion defense region must be created first.
51	LineCross Tracking	Yes	Yes	Yes	Yes	A surveillance scene (preset 51) and a line must be created first.
53	Preset Tracking	Yes	Yes	Yes	Yes	Preset Tracking
54	Preset Tracking	Yes	Yes	Yes	Yes	Preset Tracking
55	Preset Tracking	Yes	Yes	Yes	Yes	Preset Tracking
56	Preset Tracking	Yes	Yes	Yes	Yes	Preset Tracking
57	Preset Tracking	Yes	Yes	Yes	Yes	Preset Tracking
58	Preset Tracking	Yes	Yes	Yes	Yes	Preset Tracking
59	Preset Tracking	Yes	Yes	Yes	Yes	Preset Tracking
81	Left Boundary	Yes	N/A	Yes		Set a left boundary to run a scan
82	Right Boundary	Yes	Yes	Yes	Yes	Set the right boundary to run a scan, and call to activate the scan
83	Clear Preset	N/A	Yes	N/A		Clear all preset (restart/refresh the browser to take effect)
92	Default	N/A	Yes	N/A		Reset the lens to factory setting (you need to activate the camera again using the SADP tool after you call preset 92)
95	OSD Menu	N/A	Yes	N/A		Open the on-screen-display menu of the camera
98	360° Scan	N/A	Yes	N/A		Perform a 360 degrees continuous scan
100	IR ON	N/A	Yes	N/A		Turn the infrared LED on
101	IR OFF	N/A	Yes	N/A		Turn the infrared LED off
102	IR AUTO	N/A	Yes	N/A		Turn the infrared LED into AUTO mode
103	IR ALL ON	N/A	Yes	N/A		Turn both sides (high beam & low beam) of infrared LED on
Any other presets not mentioned or grayed out	Position Presets	Yes	Yes	Yes		

Note: some presets have been grayed out for future development purposes.

# 7. Auto Tracking



## 7.1 An Overview of the Tracking Algorithm

The camera can be set in one of 3 tracking modes: 1) preset tracking, 2) line cross tracking or 3) intrusion tracking. The tracking will begin once a motion is detected (with adjustable sensitivity), and will follow the moving object for a set duration (adjustable) or until the object is lost before return back to the pre-configured position.

Note: Regular motion detection is **NOT** activated when the camera is in smart tracking mode.

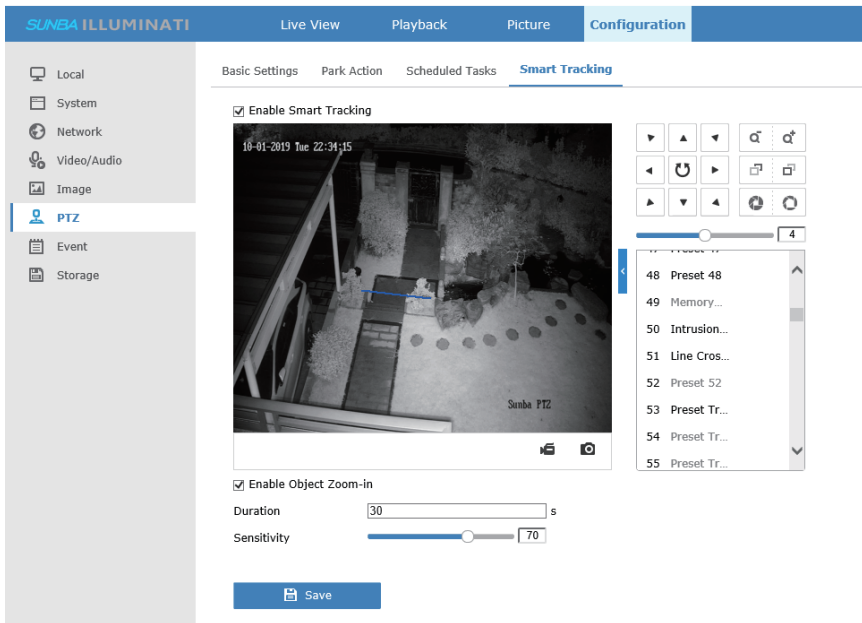

The main features of tracking is set up in **Configuration-PTZ-Smart Tracking**. It is recommended to adjust the following values subject to the installation environment of the camera.

**[Enable Object Zoom-in]** Check to enable the zoom-in feature of the camera during auto tracking.

**[Duration]** Edit to set a tracking duration (in seconds). The speed dome will stop tracking when the “duration” time is up and go back to the preconfigured position until the next motion object is detected.

**[Sensitivity]** Slide the bar to set the sensitivity of motion tracking. Higher sensitivity will enable the camera to track smaller moving objects.

## 7.2 Preset Tracking

Preset tracking is the same as home position tracking. The PTZ camera will track a moving object at a pre-designated view. For example, if the camera is installed at the house front, users would generally want the camera to start tracking an object while the camera is exactly facing the front gate. In this case, users can add a preset at their desired home position.

Steps to enable preset tracking:

1. Click  to add a preset. The presets available to serve as a tracking preset can be selected from **53-59**.



2. Click  the icon to call the preset set in step 1. The camera would then follow a moving object for a set duration (set in **Chapter 7.1**) and return back to the preset position; if the moving object is lost, the tracking will stop as well and return back to the preset position.

If the user performs any other pan tilt zoom related action, the preset tracking will stop. To continue preset tracking, add the tracking preset into **Park Action (Configuration-PTZ-Park Action)** so that the camera will actively call the designated preset as long as the speed dome doesn't receive other commands from the user.

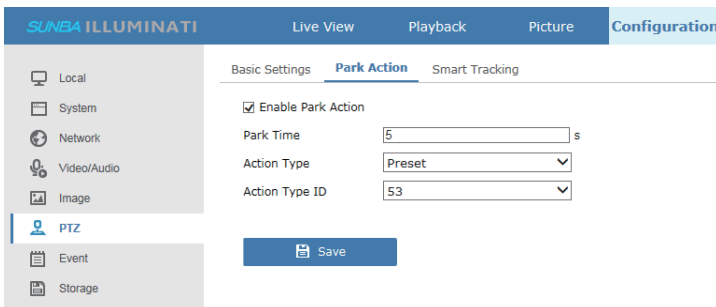

## 7.3 Line Cross Tracking

Line cross tracking is an upgrade to conventional preset tracking to improve tracking efficiency. Instead of tracking any moving object at the designated view, it would only start tracking if a line from the view has been crossed by a moving object. For example, users can draw a line on their front gate, and the camera will start following any moving object passing the line (gate).

Steps to enable line cross tracking:

1. Set the desired surveillance view as preset 51
2. Set a line cross algorithm at **Configuration->Event->Smart Event->Line Crossing Detection**

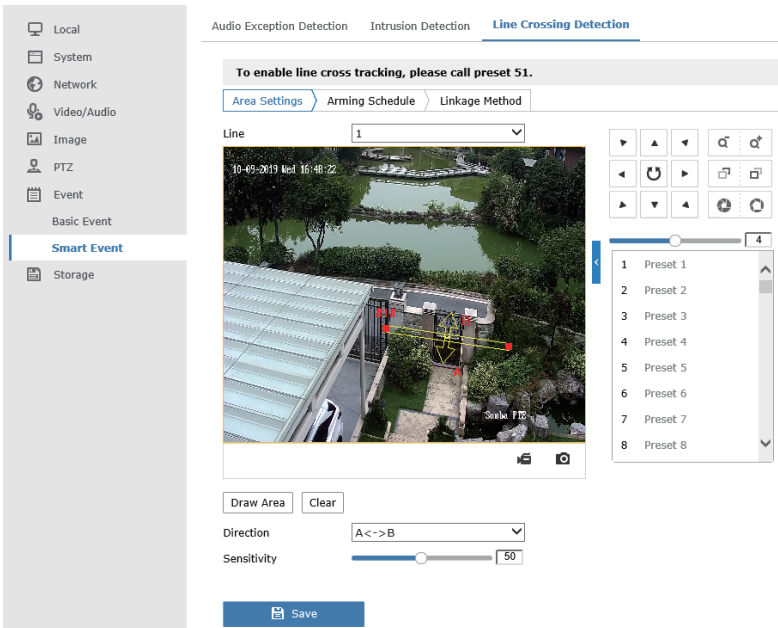

**[Draw Area]** Draw a line

**[Clear]** Clear any existing lines

**[Direction]** Select the crossing direction to trigger the alarm to be one of 1) A to B (A->B), 2) B to A (B->A) or 3) bi-lateral (A<->B)

**[Sensitivity]** The sensitivity needs to be set in **Configuration-PTZ-Smart Tracking**

3. (Optional) Add additional lines if applicable. Users can add up to 4 different lines.

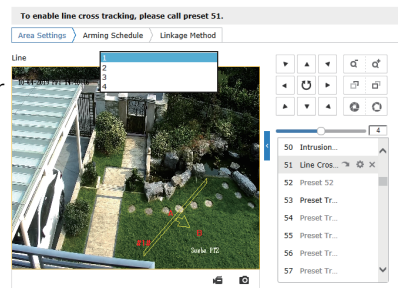

#### 4. Set the Arming Schedule

Line cross tracking can be customized to activate only at a specific time slot. By default, the tracking is scheduled to run 24/7.

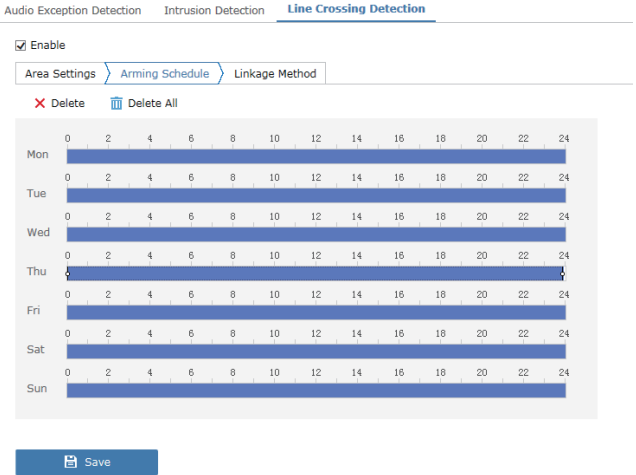

Drag the time bar to adjust the arming schedule:

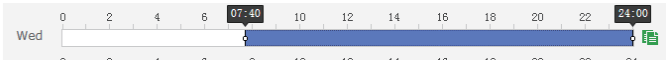

#### 5. Set up linkage methods

The linkage method sets up a series of available actions the camera can do in response to a line cross event.

**[Smart Tracking]** Activate the tracking feature for a line cross event. You **must** enable this if you want the camera to follow the moving object that triggers the alert.

**[Send Email]** Send an email alert for any line cross event. Please set up the email sender/recipient information under

**Configuration-Network-Advanced Setting-Email.**

**[Notify Surveillance Center]** Send a push alert to client software and smartphone apps such Guarding Vision app and the iFollow client software. You must register a cloud account and enable push notification on your smartphone first.

**[Upload to FTP/Memory Card/NAS]** Upload a video clip or a snapshot to FTP, memory card and NAS for any line cross motion event. Note, without a memory card (TF card), the camera is unable to upload a video to the FTP due to limited ROM. The TF card serves as the transfer media to large videos.

You can also “trigger recording” as a linkage method. This would add videos on push notifications but a TF card is required before the camera can store any video clips.

Enable

Area Settings > Arming Schedule > Linkage Method

Normal Linkage	Trigger Alarm Output	Trigger Recording
<input type="checkbox"/> Send Email <input checked="" type="checkbox"/> Notify Surveillance Center <input type="checkbox"/> Upload to FTP/Memory Car... <input checked="" type="checkbox"/> Smart Tracking	<input type="checkbox"/> A->1	<input type="checkbox"/> A1

6. Call preset 51 to activate the line cross tracking. Select preset 51 from the list and hit the call button. Once preset 51 has been called, a blue line will appear, which indicates the tracking has been activated. After that, the camera will begin tracking whenever a moving object crosses the cordon.

### 7.4 Intrusion Tracking

Intrusion tracking is an upgrade to conventional preset tracking to improve tracking efficiency. Instead of tracking any moving object at the designated view, it would only start tracking if a perimeter (a protected zone) from the view has been intruded by a moving object. For example, the perimeter can be a restricted zone in a museum where no one should be allowed to enter.

If the user performs any other pan tilt zoom related action, the line cross tracking will stop. To continue line cross tracking, add the tracking preset (50) into **Park Action (Configuration-PTZ-Park Action)** so that the camera will actively call the designated preset as long as it doesn't receive other commands from the user.

SUNBA ILLUMINATI    Live View    Playback    Picture    **Configuration**

Basic Settings    **Park Action**    Smart Tracking

Enable Park Action

Park Time:  s

Action Type:

Action Type ID:

Steps to enable intrusion tracking:

- 1) Set the desired view as preset 50
- 2) Set an intrusion detection algorithm at **Configuration->Event->Smart Event->Intrusion Detection**

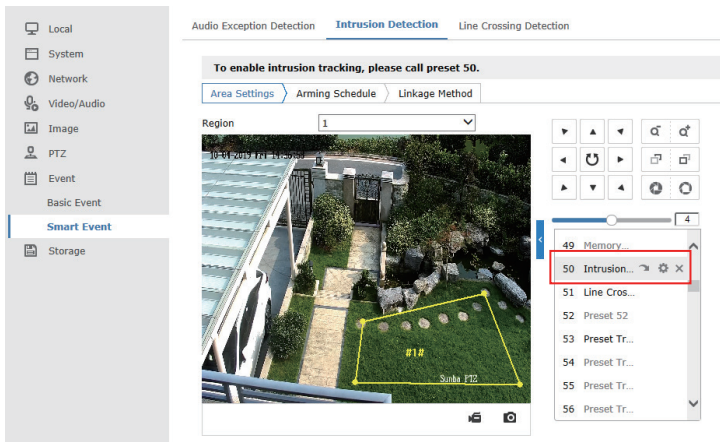

**[Draw Area]** Draw a quadrangle as the perimeter of the protected region

**[Clear]** Clear any existing regions

**[Sensitivity]** The sensitivity needs to be set in Configuration-PTZ-Smart Tracking

3. (Optional) Add additional regions if applicable. Users can add up to 4 regions by drawing different tetragons.

4. Set the Arming Schedule: [Please refer to chapter 7.3 \(Step 4\)](#).

5. Set up linkage methods: [Please refer to chapter 7.3 \(Step 5\)](#).

6. Call preset 50 to activate the intrusion tracking

Select preset 50 from the list and hit the call button. If tracking rule is enabled, a blue rectangle will appear representing the perimeter you draw. Once preset 50 has been called, the camera will begin tracking whenever a moving object enters the restricted zone.

## 7.5 Disable the tracking rules

Blue lines and rectangles represent any lines or perimeter set for the tracking, and a green moving box corresponds to the current moving object from the surveillance view. To turn off the tracking rule, go to **Configuration-Local** and set the rules to “**disable**”.

After you enable/disable the display rule, you have to reboot the device to take effect. The reboot can be performed by power cycling the unit or by clicking the “Reboot” button via **Configuration-System-Maintenance**.

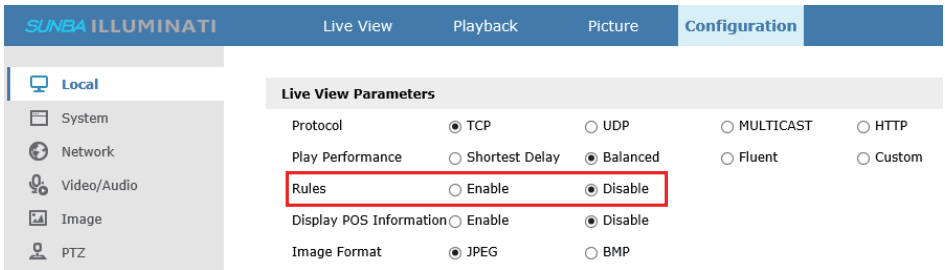

**NOTE:** Rules for smart events can not be enabled for live view in Chrome/Firefox.



## 8. Remote Access

### 8.1 P2P Cloud

P2P technology allows you to remotely connect, and configure your pan tilt zoom camera even though you are thousands miles away through Sunba encrypted cloud server. Below we will introduce how to use P2P to connect to your device through Guarding Vision app and iFollow desktop client. Note in both apps, since the camera is registered on US servers, your account will be automatically migrated if it is registered in other regions.

For smartphone app P2P access, please read **Chapter 3.3 Camera Management** by Smartphone App.

For iFollow desktop client access, go to **Device Management** and select **“Cloud P2P Device”** under Device Type. Click Login.

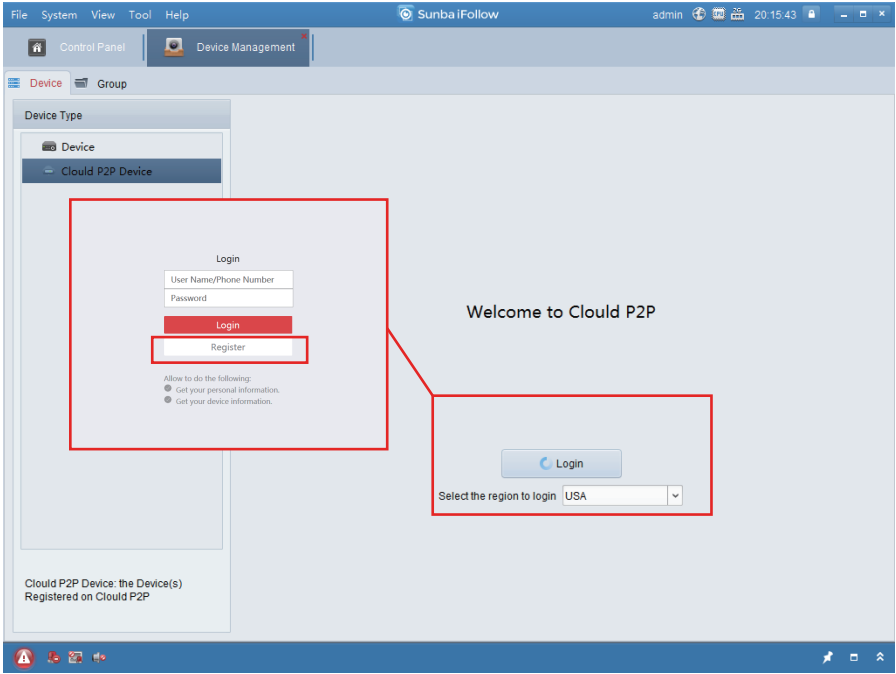

Register a cloud account and login.

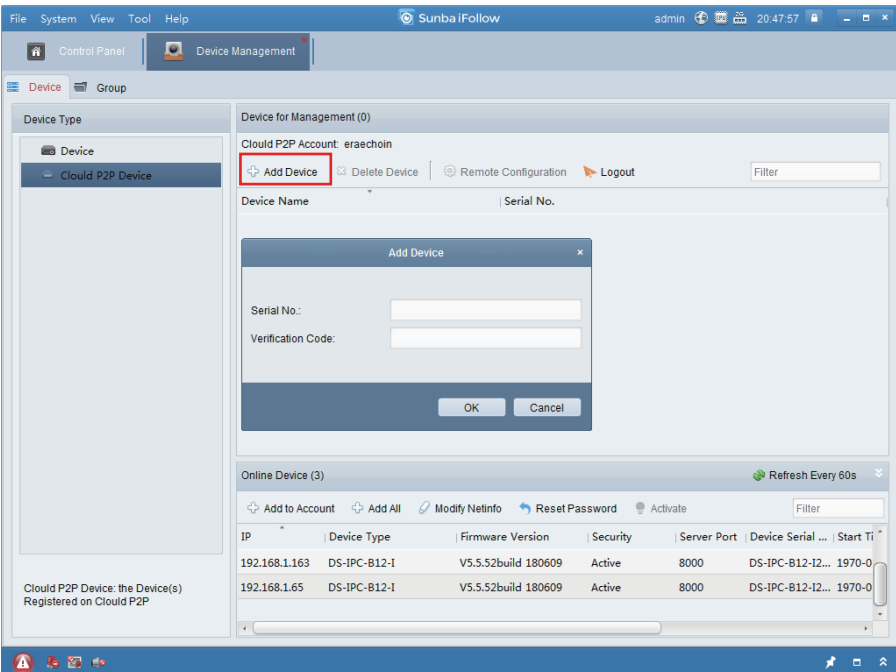

Add the camera serial number and the cloud platform verification code.

In **Configuration-Network-Advanced Settings-Platform Access**, a verification code must be added upfront before you are able to use the P2P function for remote access.

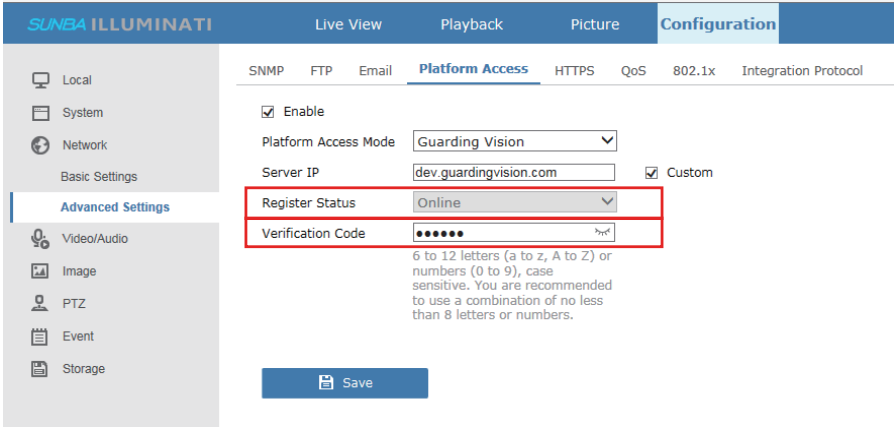

## 8.2 Port Forwarding

This is a very conventional way of remotely connecting IP cameras. By definition, port forwarding will enable remote access by mapping traffic through specific ports to specific device on the LAN (Local Area Network). For Sunba Illuminati, both HTTP/ONVIF port (80) and TCP/Media port (8000) need to be forwarded. However, this method is not the most secured way for remote control. And it is suggested to establish a firewall to deny unauthorized access. We do not recommend using this as the preferred way of remotely accessing your IP camera.

## 8.3 RTSP

Please use the following URL along with any 3rd party RTSP service provider to establish a remote broadcast stream:

`rtsp://[username]:[password]@[ip]:[port]/[codec]/[channel]/[subtype]/av_stream`

Below is an example of an IP camera with H.264, an IP of 192.168.1.10 and the default username and password.

`rtsp://admin:Admin12345@192.168.1.10:554/h264/ch1/main/av_stream`

where 554 is the default RTSP port  
h264 is the encoding format, and can be replaced by h265 or mpeg4

## 8.4 VPN

This is one of the most secured ways of accessing your device remotely but the setup can be moderately difficult for beginners. VPN allows you to remotely connect to your LAN at home as if you are physically present at the remote site. This means you can view the remote IP camera through its local IP address as if you are at home. Meanwhile, all your data will be encrypted in the VPN server. The setup varies a little different across different routers, please refer to the user manual of each router for detailed server side setup.

For more details, please refer to <http://vpn.sunbatech.com>

# 9. User Management

Go to **Configuration-System-User Management** to add, delete or modify a user. Click any existing user, and click "**modify**" to change its password or its permission range.

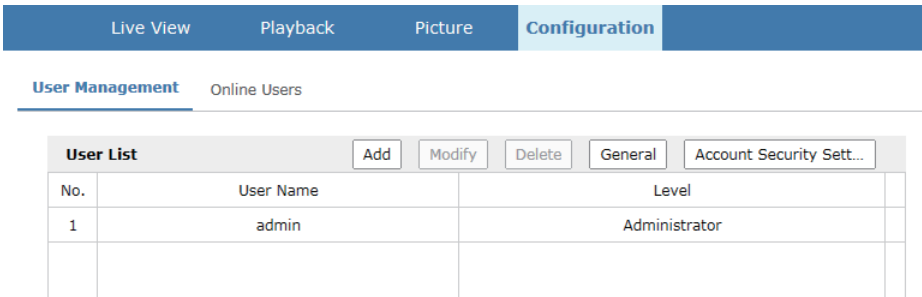

The screenshot shows a web interface for user management. At the top, there are navigation tabs: Live View, Playback, Picture, Configuration (selected), and an unlabeled tab. Below the tabs, there are two sub-sections: User Management and Online Users. The main content area is titled 'User List' and contains a table with columns for No., User Name, and Level. There are also buttons for Add, Modify, Delete, General, and Account Security Sett... above the table.

No.	User Name	Level
1	admin	Administrator

There are 3 types of user levels with different ranges of permissions:

- 1) An administrator gets access to all features by default.
- 2) An operator is able to access main features of the camera customized by the administrator.
- 3) A user can only watch live view of the camera.

### Set Security Questions and Reserved Email

Please remember to set security questions and recovery email upfront as these are necessary if you want to recover your password later. Click "**Account Security Setting**" to enter security questions and a password recovery email. .

**Security Question Configuration**

Security Question1	<input type="text" value="Your father's name?"/>
Answer	<input type="text"/>
Security Question2	<input type="text" value="Your mother's name?"/>
Answer	<input type="text"/>
Security Question3	<input type="text" value="Your head teacher's name in senior high :"/>
Answer	<input type="text"/>

**Password Recovery via E-mail**

E-mail Address	<input type="text"/>
----------------	----------------------

OK

Cancel

Click **"General"** to set the maximum online connection. Under the user management page, administrator can also see the list of online user.

The screenshot shows the SUNBA ILLUMINATI web interface. The top navigation bar includes "Live View", "Playback", "Picture", and "Configuration". The left sidebar has a "User Management" section. The main content area shows "User Management" with a sub-tab for "Online Users". Below this is a "User List" table with a "Refresh" button.

No.	User Name	Level	IP Address	User Operation Time
1	admin	Administrator	220.184.205.166	2019-10-04 14:16:22
2	admin	Administrator	192.168.1.9	2019-10-04 14:20:13

## 10. Motion Detection

To set up motion detection, please go to **Configuration-Event-Basic Event-Motion Detection** and check **"Enable Motion Detection"**. Motion detection is automatically disabled when the camera is set to advanced tracking features. Below are settings you can adjust to optimize the detection:

**[Enable Dynamic Analysis for Motion]** The red square represents the detection zone. When **Dynamic Analysis for Motion** is set to ON, anything triggering motion within the red squares will flash with green squares, which shows the detected objects. This is helpful when you are adjusting the sensitivity of motion as it reflects how sensitive a motion can be triggered with the green squares.

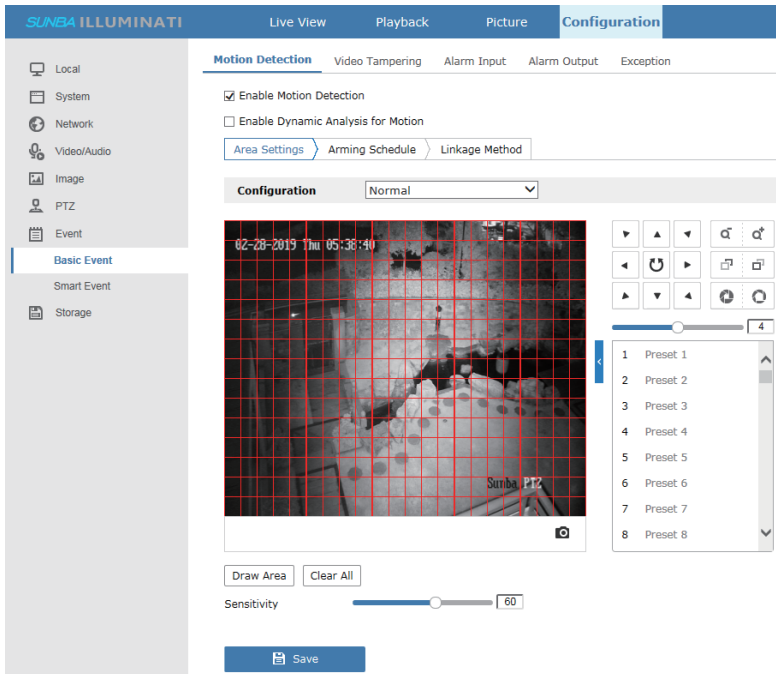

**[Draw Area]** Draw red squares to mark motion detection zone and avoid any unwanted alert zone.

**[Clear All]** Clear all drawings.

**[Scheduled Image Setting]** This is set to customize the day/night motion trigger sensitivity. The “auto switch” option will automatically separate the day/night profile when the camera enters night vision mode. The “scheduled switch” option allows you to separate the day/night profile by time.

**[Area]** Customize the day/night motion trigger sensitivity in 8 different areas.

**[Percentage]** The percentage evaluates the size of the object in a motion detected area. It is calculated as the area covered by the moving object in the frame divided by the total area. Any percentage above the set value will be considered as a motion event.

**[Sensitivity]** The bar controls how sensitive a moving object will be recognized as motion.

You can also set more parameters under the **Expert mode** by browsing the drop-down list of configuration.

The sensitivity evaluates the image pixel differences between subsequent video frames. The higher the sensitivity, the smaller the pixel difference is required to trigger a motion alert.

- Enable Motion Detection
- Enable Dynamic Analysis for Motion

Area Settings Arming Schedule Linkage Method

Configuration Expert



Scheduled Image Setti... OFF

Area 1

Sensitivity 50

Percentage 0

4

- 1 Preset 1
- 2 Preset 2
- 3 Preset 3
- 4 Preset 4
- 5 Preset 5
- 6 Preset 6
- 7 Preset 7
- 8 Preset 8

Stop Drawing Clear All

Save

# 11. FTP Communication

FTP can be setup in **Configuration-Network-Advanced Setting-FTP**.

SUNBA ILLUMINATI Live View Playback Picture **Configuration**

SNMP **FTP** Email Platform Access HTTPS QoS 802.1x Integration Protocol

Server Address 192.185.3.207 ✓

Port 21 ✓

User Name ftptest@sunbatech.com  Anonymous ✓

Password ●●●●●● ✓

Confirm ●●●●●● ✓

Directory Structure Save in the root directory

Picture Filing Interval 1 Day(s)

Picture Name Default

Upload Picture

Test

Save

**[Server Address]** The FTP service address, please enter without the “ftp://” prefix.

**[Port]** Enter the port of your FTP server. The default value is usually 21.

**[Directory Structure]** You can choose to save captured pictures in the root directory, parent directory or child directory. For parent directory and child directory, you will be asked to specify the name of the directory.

**[Picture Filing Interval]** Choose how long you would want to write a new folder in your FTP server. All pictures captured during the save time interval will be saved in one file. If you choose 1 day, then all pictures from 1 day will be saved in an individual folder.

**[Picture Name]** Customize the name of the picture file.

Please check “upload picture” to enable picture upload to the FTP server.

## 12. Waterproof Measures

The camera itself is IP 66 Waterproof Rating. However, the cable connectors may still have exposures to water under different applications. It is always recommended for users to take precautions to protect the cable connectors of the camera.

Below are 3 popular methods:

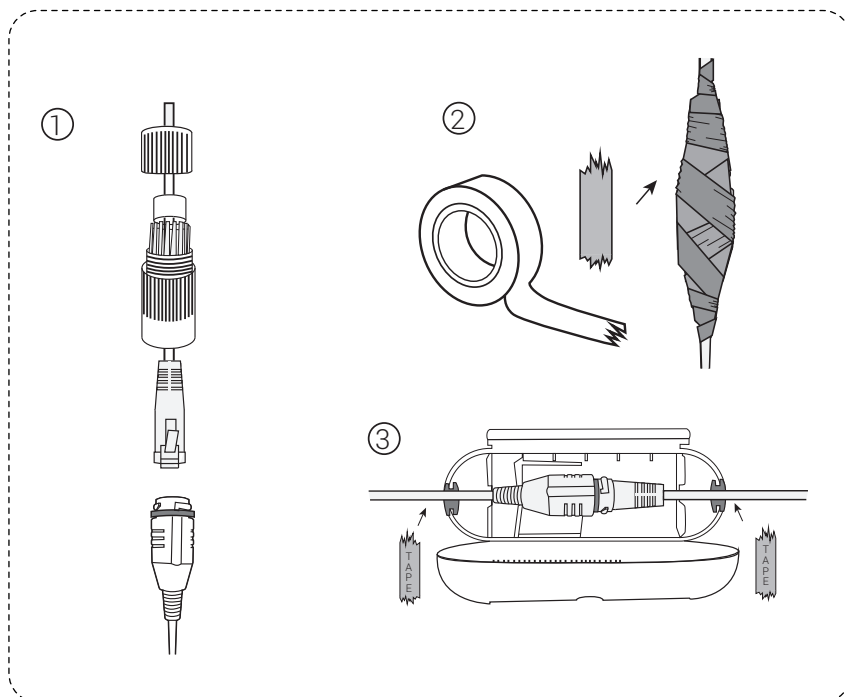

1. Sunba Illuminati has waterproof ethernet kit shipped together with the camera. To apply the waterproof kit, you have to cut the crystal head, thread the ethernet cable through the waterproof kit, and then finally use crimper tool to add the crystal head back to the cable.
2. Using electrical waterproof tape is one of the most popular ways of protecting connectors for water exposure.
3. Using waterproof connector protector together with some electrical waterproof tapes can be another option.

## 13. ONVIF Integration

To integrate to ONVIF Network Video Recorder/VMS software such as Synology, QNAP, Milestone, Blue Iris or Onvif Device Manager, it is required to enable the ONVIF protocol first on the camera and assign a unique set of username/password specifically for the ONVIF protocol.

The ONVIF configuration can be modified in

**Configuration-Network-Advanced Settings-Integration Protocol.** By default, the ONVIF protocol is enabled with the same default username/password as the camera's private protocol (admin/Admin12345).

If ONVIF is disabled, the camera will not be discoverable by any other ONVIF device/software including Blue Iris and ONVIF Device Mnager.

The ONVIF username and password can also be modified and separate from the camera's main username/password.

The screenshot displays the configuration interface for the SUNBA ILLUMINATI camera. The 'Configuration' tab is active, and the 'Integration Protocol' sub-tab is selected. The 'Enable ONVIF' checkbox is checked. The 'User List' table is as follows:

No.	User Name	Level
1	admin	Administrator

There are 3 types of user levels with different ranges of permissions:

- 1) An administrator gets access to all features by default.
- 2) An operator is able to access main features of the camera customized by the administrator.
- 3) A user can only watch live view of the camera.

To login the camera through an ONVIF program/device, you need to input the camera's IP, ONVIF username/password you set above as well as the ONVIF port. The ONVIF port for Sunba Illuminati is the same as the HTTP port. The default value is 80.

## 14. Smartphone Push Notification

After you setup the camera on your smartphone by following **Chapter 3.3**, there are a few additional steps before enable the push notification:

- 1) Ensure you have registered a cloud account withIn the Guarding Vision app instead of storing the device info locally as the notification will be sent from the cloud server.
- 2) Ensure the smartphone has enabled the notification permission for the Guarding Vision app. With iOS, go to **Settings-Notifications and select "Allow Notifications"**. The steps of managing notification for android smartphone vary between different devices.

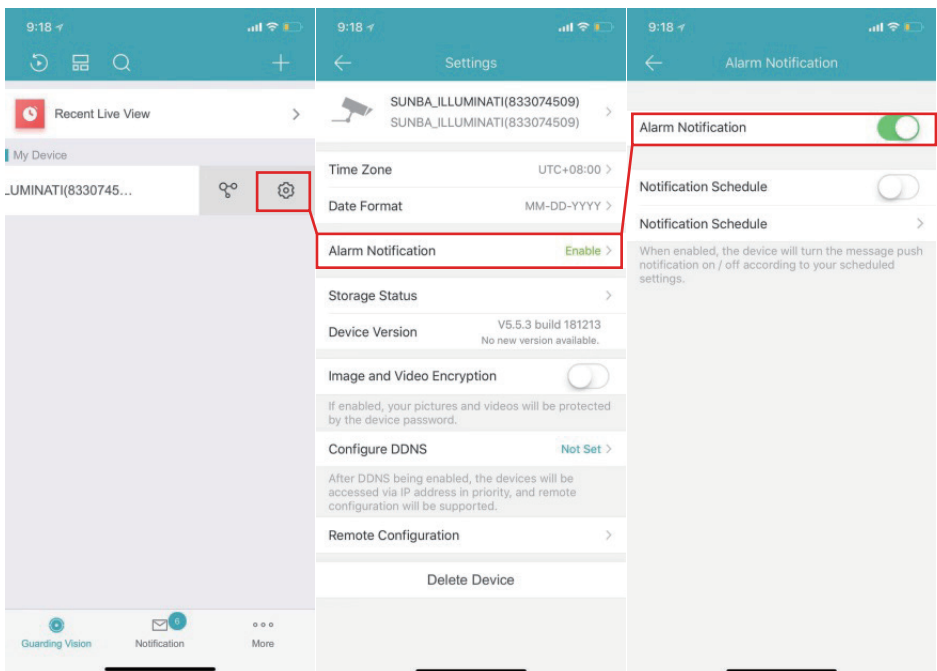

- 3) Please swipe the device to open the setting menu. Under “**Alarm Notification**”, choose “**Enable**” and set the “**Notification Schedule**” if you want. The notification schedule allows you to customize the specific time slot you want to receive the notification.
- 4) From the camera interface, please always ensure the “**Notify Surveillance Center**” option is checked for each type of event you want to receive an alert.

Area Settings > Arming Schedule > Linkage Method

<input type="checkbox"/> Normal Linkage	<input type="checkbox"/> Trigger Alarm Output	<input checked="" type="checkbox"/> Trigger Recording
<input checked="" type="checkbox"/> Send Email	<input type="checkbox"/> A->1	<input checked="" type="checkbox"/> A1
<input checked="" type="checkbox"/> <b>Notify Surveillance Center</b>		
<input type="checkbox"/> Upload to FTP/Memory Car...		

Check this to receive push notification.

Save

## 15. OSD Menu and Night Vision

The On-Screen-Display menu for Sunba Illuminati is only designed to customize the night vision activation mode and threshold.



How to activate and control the OSD?



Call to activate the OSD Menu.

Please call preset 95 to open the OSD menu. Use the up and down key to browse and move the cursor, left key to go back to the previous menu, right key to select and confirm.

IR SETTING	
- IR MODE	AUTO
IR ON SENS	210
IR OFF SENS	185
EXIT	

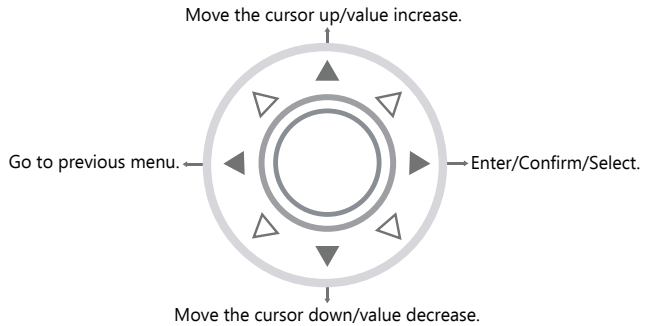

## IR MODE

**A.AUTO:** Turn on/off IR LED automatically according to darkness of ambient environment. If the value of the CURRENT LEVEL (darkness) is  $\geq$  the IR ON SENS, then the LED will be turned on automatically, vice versa. **Larger CURRENT LEVEL is equivalent to darker environment.** AUTO MODE is selected by default.

**B.MANUAL:** Turn on and off the IR LED manually. This can be accomplished using special presets 100~103 as well. Please check [specialpreset.sunba.net](http://specialpreset.sunba.net)

## IR ON SENS

The adjustable darkness threshold to turn on the IR LED, default is 210.

## IR OFF SENS

The adjustable darkness threshold to turn off the IR LED, default is 185.

### How the IR LED works:

The difference between the LED ON and LED OFF values must be at least 30 to avoid problems of IR LED blinking. Like vehicle lights, only half side of IR will be on for near view (low beam), please zoom in to enable the further view (high beam), which is the other side of the IR. Use preset 103+call to manually turn on both sides together. However, turning on both sides of IR LED on might cause torchlight effect, and may not necessarily improve the overall night vision capacity.

# 16. Reset the Camera

## 16.1 Reset the camera configuration

To reset the camera to factory reset, please access the camera web interface, and find preset 92 from the preset list. Click to select the preset, and hit the call button next to preset 92.

**NOTE:** After you reset the camera, you must re-activate the camera using the SADP tool.



## 16.2 Recover Password

### Method A. Security Questions.

#### Before You Start:

- 1) You should have set up security questions already.
- 2) You are on the same network as the camera.

Enter the camera web interface, and click “**Forgot password**”.



Select **Security Questions Verification** as the **Verification Mode**, answer all 3 questions to set a new password.

### Method B. Security Questions.

#### Before You Start:

- 1) You should have set up a reserved email account already.
- 2) You are on the same network as the camera.

Enter the camera web interface, and click “**Forgot password**”.

Select **Email Verification** as the **Verification Mode**, and export the **QR code**.



E-mail Verification

QR Code

Export QR Code

1. Click Export QR Code and save the code to local.
2. Send the code to pw\_recovery@device-service.com as an attachment. Your email account for password recovery will receive a verification code in 5 minutes.
3. Input the verification code in the text field below.

Verification Code

Next Clear

Save the QR code and send it to **pw\_recovery@device-service.com** as an attachment (PNG format).

Note:

- 1) You can use either your reserved email or any email to send this QR code. Only the reserved email will receive a valid verification code within 5 mins.
- 2) The verification code is only valid for 24 hours.
- 3) The QR code changes when you change the reserved email address.

### Method C. Reset using Safety File

If you don't have upfront security questions set, you can send security verification files to Sunba support team.

Go to SADP tool, and search the camera.

Note: If the SADP IPV4 search doesn't identify online device, make sure the camera is connected to the main router (instead of any secondary router/switch) and is **on the same network** with your computer. You can also try directly connecting the camera to the computer with Ethernet.

Select the device and click "**Forgot Password**".

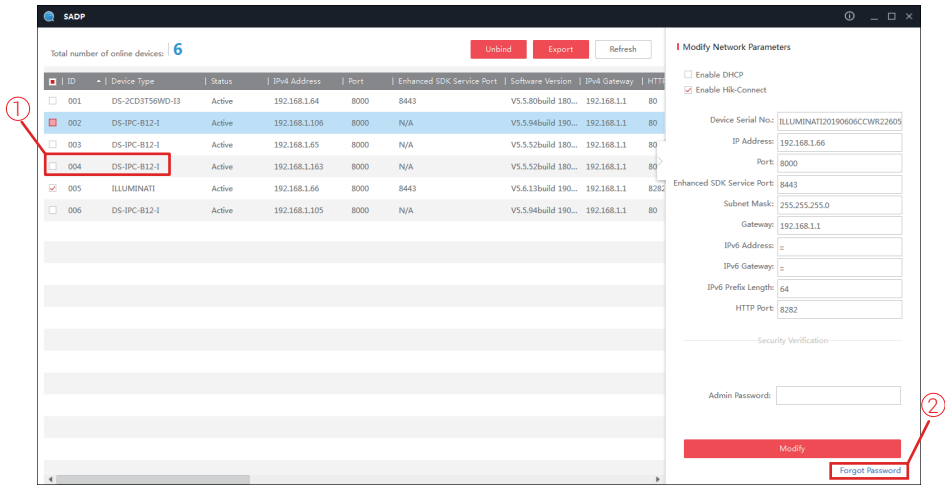

Select “Export/Import Secret Key Mode” and click “Export” to select a path that exports the XML key request file.

An XML key file will be generated automatically in the selected path.



Please send the following information to [support@sunba.net](mailto:support@sunba.net):

- 1)XML key request file or QR Code in the attachment
- 2)Order ID or proof of purchase

Sunba support team will return a verification file within 24 hours.

Note:

- 1) You can power off the computer or exit the SADP tool waiting for the key from Sunba.
- 2) Please do **NOT** power off/reboot the camera. The camera needs to stay powered before getting the return verification key, otherwise the previously sent key request file will expire.
- 3) After you receive the verification key file from Sunba, please import it within 24 hours otherwise the file will expire.

Mode:

Export/Import Secret Key Mode ▾

- 1 Step 1: Click Export to download the key request file (XML file) or take a photo of the QR code. Send the XML file or QR code photo to our technical engineers.

Export

QR code

- 2 Step 2: Input the key or import the key file received from the technical engineer to reset the password for the device.

 Input Key Import File

C:/Users/Administrator/Desktop/ILLUMINATIZ



New Password:

●●●●●●●●

Weak

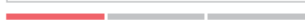

Confirm Password:

●●●●●●●●

Confirm

Cancel

## Warranty Statement

1.This product comes with a 2-year limited warranty in USA (1 year in other regions) and covering parts only. You must pay the labor fee for repair inside the warehouse. However, any parts replacements are always covered and we will be sending you videos & paper instructions on how to fix the unit. Please contact us first within the warranty period to make sure the condition of warranty is met.

2.Our warranty does not extend to any products that are physically damaged or are not under normal operating conditions as a result of misuse or improper installation on the user's end.

## Sunba's Return Policy

### Return Window

Please return your product within 30 days of your receipt. That's the official deadline the return request must be received. Exception applies for items in resellable conditions.

### RMA

We will provide a Returned Merchandise Authorization (RMA) Number for each item that satisfies the return request. Please put your RMA sheet inside the box for reference to expedite the refund process. All products must be returned within 14 days from the RMA issuing date.

### Complete Package Rule

Please return the product with its original packaging, including manuals, brackets and toolkit that come with the unit for a full refund. According to Amazon's restocking fee policy, returns with incomplete/materially different package may enable sellers to charge a restocking fee up to 15% subject to the completeness of the package. Therefore, please make sure you keep the package in good condition in the period of valid return window to avoid any additional charge.

### Refund

If you didn't receive an automatic refund within 10 days of the receipt of your return, it is either the RMA was not attached to the package or the RMA was lost by the warehouse. In this case, please kindly provide us with your tracking number so that we can match the return package and the refund will be manually processed within 24 hours. Please watch your email notifications.

For any questions, don't hesitate to reach [support@sunba.net](mailto:support@sunba.net)  
SUNBA®Technology

