

Clarke®

air



AIR FILTER/REGULATOR

MODEL NO: CAT161

PART NO: 3120175

FITTING & MAINTENANCE INSTRUCTIONS

ORIGINAL INSTRUCTIONS

GC01017-ISS2

INTRODUCTION

Thank you for purchasing this CLARKE Filter/Regulator. This unit is designed to remove up to 95% of foreign matter greater than 5 micron in size from the airline and to set the delivery pressure accurately using the gauge.

Before attempting to use this product, please read this manual thoroughly and follow the instructions carefully. In doing so you will ensure the safety of yourself and that of others around you, and you can look forward to your purchase giving you long and satisfactory service.

SPECIFICATION

Model Number	CAT161
Max Supply Pressure	213 psi / 14.7 bar
Max Outlet Pressure	140 psi / 9.7 bar
Regulating Range	7-120 psi / 0.5-8.3 bar
Air throughput	40 cfm (1140 L / min) at max @ 90psi
Air Inlet/Outlet Size	1/2" BSP female
Dimensions (D x W x H)	115 x 70 x 254 mm
Pressure Gauge Range	0-150 psi / 0-10.3 bar
Filtration	5 um
Bowl Capacity	45 cm ²
Bowl Material	Polycarbonate
Ambient/Media Temperature	5-60°C

GUARANTEE

This product is guaranteed against faulty manufacture for a period of 12 months from the date of purchase. Please keep your receipt which will be required as proof of purchase. This guarantee is invalid if the product is found to have been abused or tampered with in any way, or not used for its intended purpose. Faulty goods should be returned to their place of purchase, no product can be returned to us without prior permission.

This guarantee does not effect your statutory rights.

GENERAL SAFETY RULES



CAUTION: FAILURE TO FOLLOW THESE PRECAUTIONS COULD RESULT IN PERSONAL INJURY, AND/OR DAMAGE TO PROPERTY.

WORK ENVIRONMENT

1. Keep the work area clean and tidy.
2. Dress appropriately - do not wear loose clothing or jewellery. Tie long hair out of the way.
3. Keep children and visitors away - do not let children handle the tools.
4. Do not operate air tools where there are flammable liquids or gases.

USE OF AIRLINE EQUIPMENT

1. Stay alert and use common sense - do not operate an air tool when you are tired or under the influence of alcohol, drugs or medication.
2. Do not overreach - Keep your proper footing and balance at all times.
3. Never use oxygen, carbon dioxide, combustible gasses or any type of bottled gas as a source of power for air tools.
4. Do not exceed the maximum pressure for the airline component stated in the specification.
5. Check airline hoses for leaks or worn condition before use and ensure that all connections are secure.
6. Keep the air supply hose away from heat, oil and sharp edges.
7. Avoid damaging the components by applying excessive force.

COMPRESSED AIRLINE REQUIREMENTS



WARNING: COMPRESSED AIR CAN BE DANGEROUS. ENSURE THAT YOU ARE FAMILIAR WITH ALL PRECAUTIONS RELATING TO THE USE OF COMPRESSORS AND A COMPRESSED AIR SUPPLY.

- Use only clean, dry, regulated compressed air.
- Air compressors must comply with the appropriate European Community Safety Directives.
- A build-up of moisture in the air compressor will accelerate wear and corrosion in the air tool. Ensure any moisture is drained from the compressor daily and the airline filter is kept clean.
- If an unusually long air hose is required, (over 8 metres), the line pressure or the hose inside diameter may need to be increased.
- The air hose must be rated at least 150% of the maximum operating pressure of the air tool.

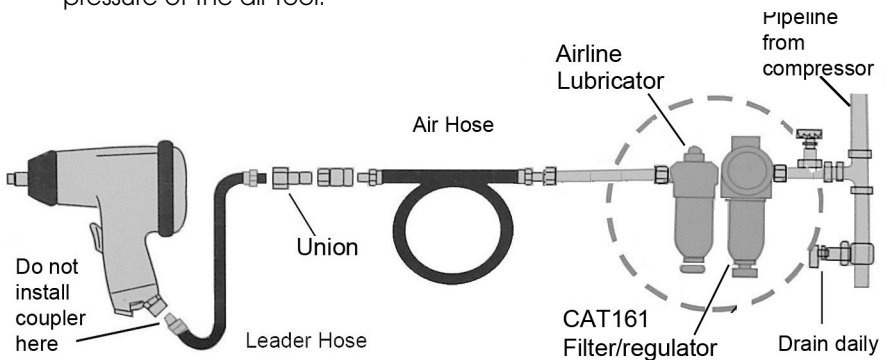

- A typical air line layout is shown above. If an automatic in-line filter & regulator are used, they will keep the tool in good condition, and the lubricator should be regularly checked and topped up with oil.
- Ensure that air pressure does not exceed that stated in the specification for the tool or regulator. Higher pressures and contaminated air will shorten the life of the air tool due to faster wear and is a possible safety hazard.

IMPORTANT! Any airline lubricator required for motorised air tools must be fitted downstream of the filter/regulator.

INSTALLATION



WARNING: COMPRESSED AIR CAN BE DANGEROUS. ENSURE THAT YOU ARE FAMILIAR WITH ALL PRECAUTIONS RELATING TO THE USE OF AIR COMPRESSORS AND COMPRESSED AIR SYSTEMS.

MOUNTING THE UNIT

This filter/regulator is supplied with a bracket for mounting it to a wall or any suitable framework.

It should ideally be connected to a fixed airline or be mounted at the outlet of the compressor.

1. Secure the bracket to the regulator using the locking ring.
 - Airflow direction is marked with an arrow on the regulator body.
2. Ensure sufficient free space above the regulator for future adjustments.
3. Ensure the compressor is turned off when making connections. Take care not to overtighten when connecting the airline unions.
4. After connection, turn on the air supply and check for air leaks. Rectify any found before starting work.
 - PTFE tape may be useful for sealing threaded connections.

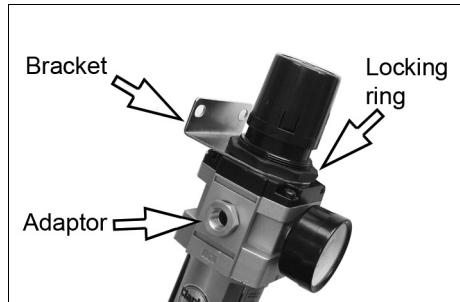

SETTING

The adjustment knob is of the locking type.

1. Adjust the delivery air pressure as required, by pulling the regulator cap upwards and then twisting clockwise to increase or anti-clockwise to reduce the outlet pressure as displayed on the gauge. When the pressure is correct, press the cap back to lock and retain the setting.
 - Turning the adjustment knob clockwise increases the pressure as displayed by the gauge. Turning counter clockwise will reduce the pressure.
 - + and - are marked on the knob.

CARE AND MAINTENANCE

A build-up of moisture in the air compressor will accelerate wear and corrosion in airline tools. Ensure any moisture is drained from the compressor routinely and that any in-line filter is kept clean.

The filter bowl will require draining by manually pulling the valve open. Ensure the water level always remains below the baffle inside the bowl.

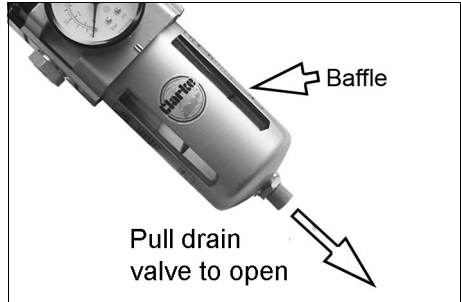

With use, the filter will become sufficiently blocked that the air throughput can become severely diminished. It should be removed and cleaned as follows:

1. Shut off the air compressor and vent any remaining air from the airline.
2. Remove the outer bowl cover by pulling the spring loaded catch down, then push up and twist the bowl 45 deg, before pulling the bowl from the body (against any frictional resistance from the O-ring).
3. Gently clean the filter and body using dishwashing liquid and allow to dry before re-assembly. Blow out internal passages in the body with compressed air.

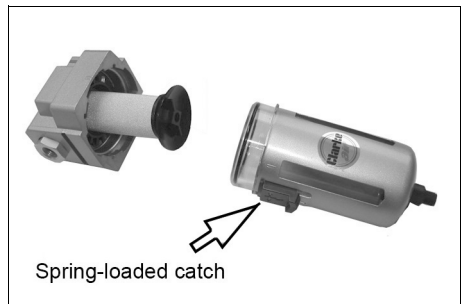

Your filter/regulator has been designed to give long and trouble free service. If, however, having followed the instructions in this booklet carefully, you encounter problems, take the unit to your local CLARKE dealer.



COMPONENT PARTS



No	Description
1	Main Body
2	Filter Element
3	Baffle
4	O-Ring
5	Bowl Assembly
6	Deflector
7	Bowl Cover
8	Drain Valve
9	1/4" BSP Adaptor
10	Diaphragm

No	Description
11	Spring
12	Valve Assembly
13	Regulator Control Assembly
14	Screw & washer
15	Locking Ring
16	Pressure Gauge
17	Regulator Valve Assembly
18	Mounting Bracket
19	Regulator Valve
20	Reducing Connector

A SELECTION FROM THE VAST RANGE OF

Clarke®

QUALITY PRODUCTS



AIR COMPRESSORS
From DIY to industrial, Plus air tools, spray guns and accessories.

GENERATORS
Prime duty or emergency standby for business, home and leisure.

POWER WASHERS
Hot and cold, electric and engine driven - we have what you need

WELDERS
Mig, Arc, Tig and Spot.
From DIY to auto/industrial.

METALWORKING
Drills, grinders and saws for DIY and professional use.

WOODWORKING
Saws, sanders, lathes, mortises and dust extraction.

HYDRAULICS
Cranes, body repair kits, transmission jacks for all types of workshop use.

WATER PUMPS
Submersible, electric and engine driven for DIY, agriculture and industry.

POWERTOOLS
Angle grinders, cordless drill sets, saws and sanders.

STARTERS/CHARGERS
All sizes for car and commercial use.



PARTS & SERVICE: 0208 988 7400

E-mail: Parts@clarkeinternational.com or Service@clarkeinternational.com

SALES: UK 01992 565333 or Export 00 44 (0)1992 565335

Clarke INTERNATIONAL Hemnall Street, Epping, Essex CM16 4LG
www.clarkeinternational.com