



Boxxer 318 - 2015 Owner's Manual

HydraMaster
11015 47th Avenue West
Mukilteo, Washington 98275

MAN-46585 Rev. A, May 20, 2015
(P/N 000-182-418)

No part of this manual may be reproduced or used in any form or by any means (i.e. graphic, electronic, photocopying or electronic retrieval systems) without the express written permission of HydraMaster. Specifications and information in this document are subject to change without prior notice. All rights reserved. © 2015 HydraMaster



000-182-418

Table of Contents

GENERAL INFORMATION.....	SECTION 1
Contact Information	1-3
Warnings, Cautions and Notices	1-4
Responsibilities	1-8
System Concept	1-10
Machine Specifications	1-11
High Altitude Operation	1-13
Local Water Precautions.....	1-13
CLEANING AND CHEMICALS.....	SECTION 2
Precautions.....	2-1
Preparing the Carpet for Extraction	2-2
Rinse and Recover	2-2
Overwetting.....	2-3
Streaking.....	2-3
Cleaning Tool Tips	2-4
OPERATING INSTRUCTIONS.....	SECTION 3
Start-up Procedure	3-1
Water Extraction Procedure.....	3-4
Shut-down Procedure.....	3-4
MACHINE MAINTENANCE.....	SECTION 4
Operational Maintenance.....	4-2
High Pressure Pump Maintenance	4-4
Vacuum System Maintenance	4-8
Descaling Procedure (Required)	4-9
Freeze Guarding.....	4-10
Tensioning the Pump Drive Belt.....	4-12
WATER AND CHEMICAL SYSTEM	SECTION 5
Water and Chemical Flow Operation.....	5-1
ELECTRICAL SYSTEM.....	SECTION 6

TROUBLESHOOTING	SECTION 7
Heating System	7-2
Chemical System.....	7-3
Engine.....	7-5
High Pressure System.....	7-9
Vacuum System.....	7-11
ASSEMBLIES AND PARTS LIST	SECTION 8
Console Assembly Parts List	8-8
Frame Assembly Parts List.....	8-11
Engine Assembly Parts List	8-14
Blower Assembly Parts List	8-16
Pump Assembly Parts List.....	8-18
Heat Exchanger Assembly Parts List.....	8-20
Silencer Assembly Parts List	8-21
Water Box Assembly Parts List.....	8-23
Dash Assembly Parts List.....	8-26
Differential Check Valve Assembly Parts List	8-27
By-Pass Valve Assembly Parts List	8-28
Orifice Assembly Parts List.....	8-29
Idler Pulley Assembly Parts List.....	8-30
Exhaust Assembly Parts List	8-31
65 Gallon Universal Recovery Tank (URT) Assembly Parts List	8-34
100 Gallon Universal Recovery Tank (URT) Assembly Parts List	8-36
100 Gallon Universal Recovery Tank (URT) Cover Assembly Parts List.....	8-37
Vacuum Relief Valve Assembly Parts List	8-38
70 Gallon Fresh Water Tank (FWT) Assembly Parts List.....	8-41
Dura-Flow APO 90 Degree Assembly Parts List.....	8-43
APO Pump Assembly Parts List	8-44
APO Connection Kit Assembly Parts List	8-45
Hose Routings	8-46
HOW TO ORDER PARTS	SECTION 9
Warranty Parts Orders.....	9-1
Parts Orders	9-1
Emergencies.....	9-1

WARRANTY INFORMATION	SECTION 10
Blower	10-1
High Pressure Water Pump	10-1
Recovery Tank	10-2
Chemical System	10-2
Control Panel	10-2
Vacuum and Solution Hoses	10-2
Cleaning Wand	10-2
Water Heating System	10-2
Hard Water Deposits	10-2
Warranty Procedure.....	10-3
 ACCESSORIES AND CHEMICAL SOLUTIONS.....	 SECTION 11

List of Figures

Figure 1-1. Hard Water Map of Mainland United States.....	1-14
Figure 3-1. Location of Throttle, Choke and Pump-In/Pump Clutch Switch	3-1
Figure 3-2. Front View of Boxxer 318 Console.....	3-2
Figure 3-3. Side View of Boxxer 318 Console.....	3-3
Figure 4-1. Servicing the Valves.....	4-5
Figure 4-2. Recirculation Fitting.....	4-9
Figure 5-1. Flow Diagram - View 1 of 3.....	5-3
Figure 5-2. Flow Diagram - View 2 of 3.....	5-4
Figure 5-3. Flow Diagram - View 3 of 3.....	5-5
Figure 6-1. Electrical Schematic.....	6-3
Figure 6-2. Wiring Diagram - View 1 of 2	6-4
Figure 6-3. Wiring Diagram - View 2 of 2	6-5
Figure 8-1. Adhesive/Sealant Material Reference.....	8-2
Figure 8-2. Console Assembly - View 1 of 5.....	8-3
Figure 8-3. Console Assembly - View 2 of 5.....	8-4
Figure 8-4. Console Assembly - View 3 of 5.....	8-5
Figure 8-5. Console Assembly - View 4 of 5.....	8-6
Figure 8-6. Console Assembly - View 5 of 5.....	8-7
Figure 8-7. Frame Assembly - View 1 of 2	8-9
Figure 8-8. Frame Assembly -View 2 of 2	8-10
Figure 8-9. Engine Assembly - Part 1 of 2.....	8-12
Figure 8-10. Engine Assembly - Part 2 of 2.....	8-13
Figure 8-11. Blower Assembly - View 1 of 2	8-15
Figure 8-12. Blower Assembly - View 2 of 2.....	8-16
Figure 8-13. Pump Assembly - View 1 of 2	8-17
Figure 8-14. Pump Assembly - View 2 of 2	8-18
Figure 8-15. Heat Exchanger Assembly.....	8-19
Figure 8-16. Silencer Assembly.....	8-21
Figure 8-17. Water Box Assembly	8-22
Figure 8-18. Dash Assembly - View 1 of 2	8-24
Figure 8-19. Dash Assembly - View 2 of 2	8-25

Figure 8-20. Differential Check Valve Assembly.....	8-27
Figure 8-21. By-Pass Valve Assembly.....	8-28
Figure 8-22. Orifice Assembly	8-29
Figure 8-23. Idler Pulley Assembly.....	8-30
Figure 8-24. Exhaust Assembly.....	8-31
Figure 8-25. 65 Gallon Universal Recovery Tank (URT) Assembly View 1 of 2.....	8-32
Figure 8-26. 65 Gallon Universal Recovery Tank (URT) Assembly - View 2 of 2.....	8-33
Figure 8-27. 100 Gallon Universal Recovery Tank (URT) Assembly.....	8-35
Figure 8-28. 100 Gallon Universal Recovery Tank (URT) Cover Assembly	8-37
Figure 8-29. Vacuum Relief Valve Assembly	8-38
Figure 8-30. 70 Gallon Fresh Water Tank (FWT) Assembly - View 1 of 2.....	8-39
Figure 8-31. 70 Gallon Fresh Water Tank (FWT) Assembly View 2 of 2	8-40
Figure 8-32. Dura-Flow APO 90 Degree Assembly.....	8-42
Figure 8-33. APO Pump Assembly.....	8-44
Figure 8-34. APO Connection Kit	8-45

1- General Information

The Boxxer™ 318 is a carefully engineered truckmount by HydraMaster for carpet cleaning, upholstery cleaning and water extraction/restoration as well.

The system utilizes an internal combustion engine to provide the power necessary to turn both a blower (also referred to as a vacuum pump) and a high pressure water pump.

The heat of the engine and blower exhausts is transferred to the high pressure water in the heat exchanger of the system.

Finally, the chemical is injected into the pressurized water stream and the heated solution is delivered to the cleaning tool.

The solution is recovered by the vacuum generated by the blower and is collected in the recovery tank for proper disposal.



To provide an on-board fresh water source in a space-saving configuration, the 70 Gallon Sub-Mount RMT Freshwater Tank (P/N 000-163-212) is available as an option.

BOXXER 318

It is the purpose of this manual to help the technician properly understand, maintain and service the truckmount. By following these guidelines carefully, you can expect years of reliable operation.

This section contains the following information:

- Contact Information
- Warnings, Cautions and Notices
- Responsibilities
- System Concept
- Machine Specifications
- High Altitude Operation
- Local Water Precautions

CONTACT INFORMATION

If you have any questions regarding the operation, maintenance or repair of this machine, please contact your local distributor.

To find a local distributor, please visit our website at <http://hydramaster.com/HowToBuy/DealerLocator.aspx>

If your question cannot be resolved by your distributor or by the information within this manual, you may contact HydraMaster direct using the following phone numbers.

HOURS	TELEPHONE NUMBERS	E-MAIL ADDRESSES
Monday-Friday 7:00 a.m. to 5:00 p.m. Pacific Time	Technical Support (800) 426-1301 FAX : (800) 426-4225	Technical Support techsupport@hydramaster.com
	Customer Service/Parts (800) 426-1301 FAX : (800) 426-4225	Customer Service/Parts parts@hydramaster.com

When calling your distributor, be sure to reference the serial number and date of purchase.

FOR YOUR REFERENCE:

Serial No. _____

Date of Purchase: _____

Purchased From (Distributor): _____

WARNINGS, CAUTIONS AND NOTICES

WARNING

HydraMaster uses this WARNING symbol throughout the guide to warn of possible injury or death.

CAUTION

This CAUTION symbol is used to warn of possible equipment damage.

NOTICE

This NOTICE symbol indicates that federal or state regulatory laws may apply, and also emphasizes supplemental information.

⚠ WARNING

During the operation of the truckmount many components are in motion. Never touch any part of the truckmount that is in motion. Serious injury may result.

⚠ WARNING

During the operation of the truckmount many surfaces will become extremely hot. Never touch hot surfaces. Serious injury may result.

⚠ WARNING

The operation of this truckmount can produce noise levels exceeding 85 decibels to a distance of 10 feet. The Occupational Safety and Health Administration (OSHA) recommends the use of hearing protective equipment if a person is exposed to an average of 85 decibels over an eight hour period. Check with local and state agencies concerning hearing conservation rules.

⚠ WARNING

During the operation of the truckmount carbon monoxide and other toxic fumes are produced. Position the vehicle so that any fumes produced will be directed away from inhabited areas and any points of building entry (doors, windows, air conditioning units, fans, etc.). Do not occupy the vehicle while the truckmount is in operation. Serious injury may result.

⚠ WARNING

During the operation of the truckmount chemicals known to the State of California to cause cancer, birth defects and other reproductive harm are produced by the engine exhaust.

⚠ WARNING

Never operate the truckmount with a portable gas container inside the vehicle. Doing so will increase the risk of fire and explosion. Serious injury or death may result.

⚠ WARNING

Transporting a vented fuel container that presently contains, or has ever contained in the past, a flammable liquid is strictly forbidden by HydraMaster and by federal and state regulations. Doing so will increase the risk of fire and explosion. Serious injury or death may result.

BOXXER 318

▲ WARNING

Never smoke in or around the truckmount. Doing so will increase the risk of fire and explosion. Serious injury or death may result.

CAUTION

During the operation of the truckmount the exhaust system will become extremely hot. Keep all flammable materials away from the truckmount exhaust system. Failure to do so will increase the risk of fire and explosion. Serious property damage may result.

CAUTION

Never operate the truckmount when the vehicle is tilted more than 10 degrees in any direction. Doing so will result in improper lubrication of the internal components, and will increase the risk serious component or engine damage.

CAUTION

Never perform cleaning operations when the truckmount engine is running at the IDLE throttle position. Failure to do so will increase the risk of serious component or engine damage.

CAUTION

Never operate the truckmount with the vehicle doors closed. Doing so results in extremely high temperatures inside the vehicle and will lead to serious component or engine damage.

CAUTION

Never use concentrated acids or solvents (including d-limonene) in the truckmount water system or chemical system. Use of these products will cause serious component damage.

CAUTION

Never operate the truckmount with a water hardness reading measuring 3.0 grains per gallon or higher. Using reading than 3.0 grains per gallon will cause scale to build up inside the truckmount water system. Scale build up causes serious component damage. Test all water prior to use and use water softening equipment if necessary.

CAUTION

Never allow water to freeze inside the truckmount. Serious component damage will occur. Perform all freeze guarding procedures outlined in the digital Owner's Manual.

CAUTION

Many vehicles have critical components mounted directly below the floor that can easily be damaged. Before drilling holes in the floor of the vehicle, inspect the underside of the vehicle for critical components. Failure to do so may result in damage to the vehicle.

CAUTION

During the operation of this equipment, surfaces will become hot. Do not allow components such as hoses to touch hot surfaces. Failure to heed this warning can result in equipment damage which is not covered by warranty.

RESPONSIBILITIES

The Purchaser's Responsibilities

Prior to purchasing a van, ensure that the payload is suitable for all of the equipment that will be installed and transported. This includes and is not limited to: the truckmount, recovery tanks, fresh water tanks and on-board water, hose reels, hoses, cleaning tools, chemicals, drying equipment, etc. Payload capacity information is available through the auto dealer, the manufacturer's web site, and is also located on the door pillar of the driver's side door.

Purchase a heavy duty Group 24 (550 CCA or better) battery for this truckmount. This is normally available from the installation dealer.

Prior to dropping your van off at the distributor for the truckmount to be installed, have a spray-on bed liner applied to the floor such as Rhino Lining® or Line-X®.

Prior to operating the truckmount read this manual in its entirety and familiarize yourself with the information contained here. Special attention should be paid to all cautions and warnings.

The distributor is responsible for the correct installation of the truckmount. The distributor is also responsible to train you in the correct and proper operation and maintenance of the truckmount.

NOTICE

Any modification of the truckmount may void the warranty.

The Distributor's Responsibility

Acceptance of Shipment

Before accepting the truckmount, check the following:

- The truckmount should be free from any damage during shipping. Do not sign the delivery receipt until you have closely inspected the truckmount and noted any damage on the delivery receipt. Hidden damage may be present even if the box looks okay. It is recommended that the box be opened before signing for the shipment.
- Check the packing list and verify that all items are accounted for.

Installation Responsibilities

- Ensure proper payload capacity. It is the distributor's responsibility to verify that the equipment package does not exceed the vehicle capacity.
- Ensure installation of a safe fuel tap system and through-floor fittings as provided by HydraMaster.
- Proper placement of the truckmount, recovery tank, fresh water tank, and accessories in the vehicle and securing them with bolts and back up plates. The distributor should verify that the owner is in agreement with the layout.
- Ensure proper connection of the fuel lines.
- Ensure proper connection and installation of the battery. Verify that the battery is in accordance with HydraMaster's recommendation.
- Check the pump, vacuum blower and engine oil levels prior to starting the truckmount.
- Start and run the truckmount and check that all systems function properly.
- Test all hoses, wands, etc. for correct operation.
- Ensure timely return of the document package.

Training

The distributor should provide a thorough review of the operation manual with the purchaser along with instruction and familiarization in:

- How all the truckmount's systems function.
- All safety precautions and their importance.
- How to correctly start and shut down the truckmount.
- How to correctly clean with the truckmount.
- Where and how often to check and change component oil levels.
- Freezing damage and how to avoid it. This includes explaining proper freeze guarding procedures.
- How to do basic troubleshooting of the truckmount.
- Hard water damage and how to avoid it. This includes how to determine if hard water exists in your area and the installation and use of water softening systems.
- The truckmount's warranty and warranty procedures.

BOXXER 318

SYSTEM CONCEPT

The system utilizes an internal combustion engine to provide the power necessary to turn both a vacuum pump and a high pressure water pump.

The heat of the engine and blower exhausts is transferred to the high pressure water in the finned tube heat exchanger of the system.

Finally, the chemical is injected into the pressurized water stream and the heated solution is delivered to the cleaning tool. The solution is recovered by the vacuum generated by the vacuum pump. This solution is collected in the recovery tank for proper disposal.

MACHINE SPECIFICATIONS

Frame Dimensions	24.0" W x 31" H x 36" D	
Weight	570 lbs	
Engine- Briggs and Stratton Vanguard 18HP	Oil Type	Synthetic 5W-30
	Capacity	Approx. 1 1/2 quarts (48 oz.) when changing oil and filter
	Engine rpm	3,150 rpm
	Fuel Consumption	1.0 gph
Ignition	Electric Key Start	
Vacuum Blower- Tuthill 3006 Competitor Plus SL (Dual Splash Lubrication)	Max. Vac.	12" Hg
	Oil Type	PneuLube or other ISO 100 rating
	Gear End Capacity	Approx. 7.0 oz.
	Drive End Capacity	Approx. 5.0 oz.
	Blower rpm	3,150 rpm
Water Pump	Oil Type	30W non-detergent
Electric Clutch	Capacity	Approx. 8.0 oz.
	Pump Rate	3.5 gallons per minute
	Pump rpm	1,750 rpm
Operating Pressure	0 - 1,000 psi	
Chemical System	Stainless Steel Last Step Chemical Injection	
Heating System	Finned Tube Heat Exchanger	

BOXXER 318

Standard Equipment	High Pressure Hose	1/4" High Temperature Lined/ Vinyl Cover - 100 ft.
	Vacuum Hose	2" Vacuum Hose- 100 ft.
		1-1/2" Wand Whip Line- 10 ft.
	Recovery Tank	65 gallon MaxAir Universal Tank
	Cleaning Wand	Stainless Steel S-bend
		Replaceable Grip
		Rebuildable Solution Valve
	Chemical Jug	5 gallon
	Battery Box	
	Van Decal	
	Van Installation Kit	
	Owner's Manual (on CD)	
	Owner's Guide (paper copy)	
Optional Equipment	Recovery Tank	100 Gallon MaxAir Universal Tank - Single Port
	Fresh Water Tank	70 Gallon Rotomolded Tank
		85 Gallon Rotomolded Tank
	Automatic Pump Out (APO)	Dura-Flow APO

HIGH ALTITUDE OPERATION

Elevation plays a key role in how the truckmount will operate. Operation at high altitude (above 5,000 ft.) may require a high-altitude carburetor jet. Use of this jet at high altitude will improve power, reduce fuel consumption and help reduce excessive carbon build-up in the exhaust and heat exchanger systems.

Contact the local Briggs and Stratton dealer or HydraMaster to obtain the proper jet size. Your local Briggs and Stratton dealer can be located at <http://www.briggsandstratton.com/us/en/support/dealerlocator>.

LOCAL WATER PRECAUTIONS

The quality of water varies greatly. Many areas have an excess of minerals in the water which results in what is commonly called “hard water.” These minerals tend to adhere to the insides of heater coils and other parts of the machines causing damage and a loss of cleaning effectiveness. This influences the reliability and efficiency of equipment in direct proportion to the level of hardness.

Hard Water Advisory

HydraMaster recognizes that any hard water deposits which might occur within the water system of our truckmounts is a serious problem. The precision technology of truckmount heat exchanger systems is intolerant of any foreign material. Hard water deposits will ultimately decrease the performance of the system and are expected to seriously lower the reliability of the machine.

To validate a machine’s warranty, HydraMaster requires that all machines operating in designated “Hard Water Areas” (3.0 grains or more per gallon) be fitted with a water softening system, or a properly installed magnetic-type descaler must be used and maintained. Periodic descaling or acid-rinsing alone is not adequate in these areas. HydraMaster does not recommend any particular type or brand; however, the relative effectiveness of some types of magnetic descalers or softeners may require additional periodic use of descaling agents.

HydraMaster also recommends, in the strongest possible terms, that machines in all areas be fitted with a water softening system for improved operation and reliability.

CAUTION

Failure to take appropriate measures to prevent scale build up can result in system failure and loss of warranty on affected parts.

Hard Water Area Map

The hard water map, shown in Figure 1-1, defines hard water areas in the continental United States which compromise fluid related components such as hoses, fittings, heaters, pumps, valves and water-cooled engines. For other countries, hard water area maps can be obtained from geological societies.

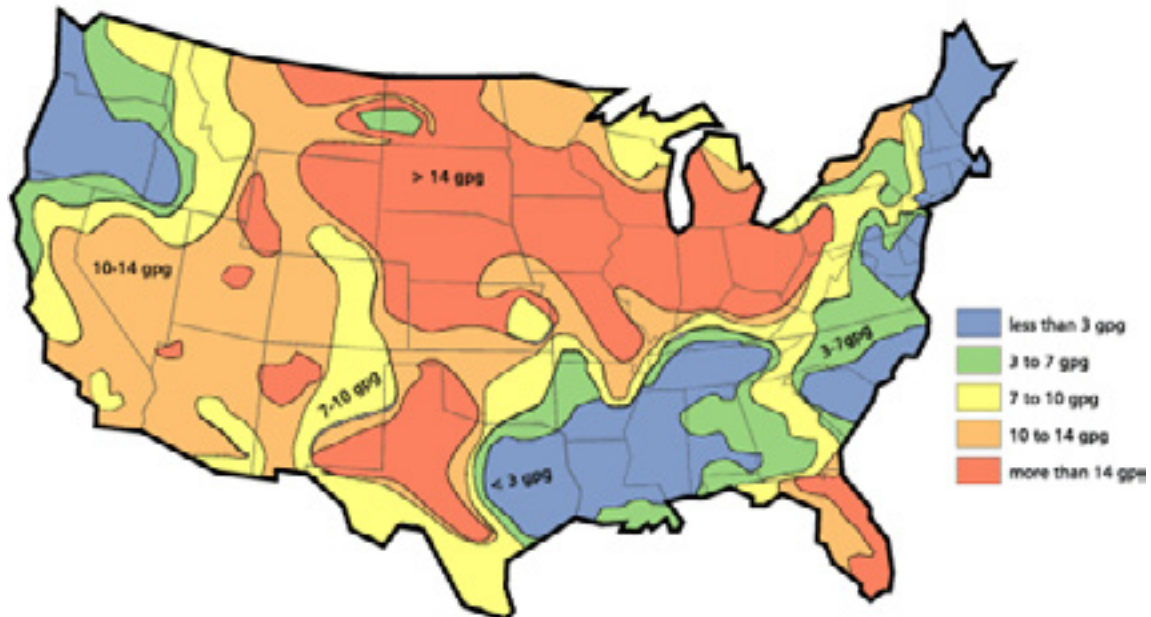

Figure 1-1. Hard Water Map of Mainland United States

NOTICE

The map shown in Figure 1-1 is provided for general reference only. Water hardness in your geographical location should be confirmed by testing.

Water Softener

Cleaning efficiency and equipment life is increased, chemical use decreased, and the appearance of cleaned carpets enhanced when water softeners are incorporated in hard water areas. HydraMaster strongly urges the use of water softener units with the Boxxer 318 in areas exceeding 3.0 grains per gallon.

Failure to use a water softener in these areas will invalidate the machine's warranty. Referring to the hard water area map shown Figure 1-1, determine the quality of water in your area and take immediate action if the water hardness exceeds 3.0 grains per gallon.

The relatively low cost of a water softener service is more than made up for by an increased life of machine parts, reduced chemical costs and continued cleaning efficiency. The water softener will also increase the effectiveness of the cleaning chemicals, therefore less chemical will be needed.

Contact a water softener distributor in your area for information on the rental of a simple water treatment unit to carry in your truck. Be sure to charge the water softener in accordance with the capability of the softener.

For example: If the softener will treat 900 gallons of water and the machine uses an average of 30 gallons/hour, for an average of 5 hours a day, this equals 150 gallons per day). In 6 days the machine would use 900 gallons of water. Therefore, the softener would need to be charged every 6 working days for maximum softening.

BOXXER 318

Waste Water Disposal Advisory

There are laws in most communities prohibiting the dumping of recovered “gray” water from carpet cleaning in any place but a sanitary treatment system.

The cleaning rinse water, recovered into your unit’s vacuum tank, contains materials such as detergents, and must be safely processed before entering streams, rivers and reservoirs.

In most cases, an acceptable method of waste water disposal is to discharge into a municipal sewage treatment system after first filtering out solid material such as carpet fiber. Access to the sanitary system can be obtained through a toilet, laundry drain, RV dump, etc. Permission should first be obtained from any concerned party or agency.

One disposal method which usually complies with the law is to accumulate the waste water and haul it to an appropriate dump site. Another solution to the disposal problem is to equip your Boxxer 318 with an Automatic Pump-Out System (APO). These systems are designed to remove waste water from the extractor’s recovery system and actively pump the water through hoses to a suitable disposal drain.

HydraMaster makes an APO System which can be ordered with new equipment or installed later.

When properly configured, the systems will continuously monitor the level of waste water and pump it out simultaneously with the cleaning operation. The hidden benefit of this process is that the technician does not have to stop his/her cleaning to empty the recovery tank.

NOTICE

IN ACCORDANCE WITH EPA, STATE AND LOCAL LAWS, DO NOT DISPOSE OF WASTE WATER INTO GUTTERS, STORM DRAINS, STREAMS, RESERVOIRS, ETC.

The penalties for non-compliance can be serious. Always check local laws and regulations to be sure you are in compliance.

2 - Cleaning and Chemicals

Your HydraMaster truckmount has been engineered using the latest and most sophisticated technology available to produce the finest carpet cleaning results possible. Despite this, it remains only a tool of the carpet cleaning trade and can produce only as good a job as the person operating it.

HydraMaster strongly recommends attending an Institute of Inspection, Cleaning and Restoration Certification (IICRC) approved school as soon as possible and to always follow the IICRC guidelines when cleaning.

This section describes the carpet cleaning procedure in the following areas:

- Precautions
- Preparing the Carpet for Extraction
- Rinse and Recover
- Overwetting
- Streaking
- Cleaning Tool Tips

PRECAUTIONS

The use of some chemicals (such as concentrated acids and/or solvents) in your truckmount can seriously damage the internal plumbing and high pressure pump.

HydraMaster strongly recommends purchasing a water softener to prevent the buildup of scale and hard water deposits in your truckmount.

HydraMaster recommends only the use of chemicals containing rust and corrosion inhibitors and water softening agents to prevent chemical buildup which may lead to component failure and warranty invalidation.

CAUTION

Increased demand for a neutralizing rinse results in the need for special care when using these acid based chemicals in your truckmount. The negative side of these products is the corrosive effects the acid can have on metals, including fittings, pumps, heat exchangers, etc.

HydraMaster's **ClearWater Rinse™** has been formulated to protect vital components. HydraMaster will not warranty parts that have been damaged from using acid products that have obviously caused failures.

PREPARING THE CARPET FOR EXTRACTION

Pre-Vacuum the Carpet

Whether you instruct the customer to pre-vacuum or you offer it as part of your service, proper vacuuming will make your job easier with superior end results. The more time spent removing loose particulate soil, the easier it will be to remove the oily soil stuck to the fibers.

Pretreat the Carpet

This process of applying traffic lane type chemicals to the carpet (whether by sprayer or rotary scrubber) is essential prior to extraction with your truckmount.

By applying cleaning agents to the carpet and letting them dwell 10-20 minutes prior to rinsing, you allow the product to dissolve and emulsify the oily, sticky binders holding the soil to the fiber. This will allow more soil to be removed in one or two cleaning passes and help prevent over-wetting.

Remember the solution coming out of your cleaning tool is only in contact with the carpet fiber for a few seconds. Relying on the rinse detergent to do the majority of the cleaning will result in overly long dry times and excess detergent residue left in the carpet.

HydraMaster recommends the use of our pre-sprays: **Fastbreak™** for residential carpet and **Blitz™** for commercial carpet needs.

RINSE AND RECOVER

Whether you are using a wand or a rotary extraction tool, you should clean an area approximately 3 ft. x 3 ft. with the solution valve open then immediately go over that area with vacuum only to remove any excess moisture.

CAUTION

Olefin fiber is becoming more popular, particularly in commercial installations. The process mentioned above can leave excessive residual moisture because olefin fibers will not absorb any of the cleaning solution. You must only apply solution during the backward stroke of the wand so it can be immediately captured by the vacuum head. RX-20® users should follow each pass with a dry pass. Failure to follow this procedure will cause solution to flow to the back of the carpet along with some of the soil. This, along with any soil imbedded in the backing, will be wicked to the surface of the fibers as the carpet dries.

HydraMaster recommends the following rinse aids: Alkaline - **Hydra-Dri Powder™** or **Hydra-CleanLiquid™**. Acid - **Clear Water Rinse™**.

NOTICE

For more information about HydraMaster's complete chemical product line, visit this webpage: <http://hydramaster.com/Products/Chemicals.aspx>

OVERWETTING

Overwetting is an annoyance to all concerned. Extended drying times will leave the customer with a negative impression of both the cleaning company and the process used.

There are several factors that will cause over-wetting:

1. Too few vacuum strokes.
2. Clogged vacuum blower filter or Recovery Tank lid not sealing properly.
3. Recovery Tank drain valve left partially open.
4. Obstructed, cut or kinked vacuum hoses.
5. Obstructed vacuum hoses while cleaning a heavily foam-saturated carpet (it is recommended to use a crystal type defoamer distributed evenly over the carpet).

STREAKING

Streaks in the carpet can appear in both clean or dirty areas and normally appear in heavily soiled, light colored carpets.

Possible reasons of streaking may include:

1. Clogged or improperly angled spray nozzles.
2. Spray nozzles that overlap, concentrating the solution.
3. A partially clogged vacuum head.
4. Inconsistent solution temperature.

CLEANING TOOL TIPS

Wands

With a wand, keep cleaning strokes short, front to back, and run a “dry pass”.

After pulling the wand for a strip of 3 or 4 ft long with the solution trigger activated, go back up to the top of the stroke, and make a “dry “ pass [i.e. no solution flowing]. This gives the wand a second chance to pick up the solution on the carpet.

If you do not run a dry pass, the carpet can take longer to dry, and, possibly, the pad under the carpet can become saturated.

Be aware of the carpet seams; try to use strokes that are parallel with the seam. Avoid pulling the wand across the seam. Every stroke can peel the seam connection and pull the carpet off the floor.

Also, tilt the wand handle down [head up] to move the tool forward, and away from you, on the carpet. This means less pull on the carpet and less work for you.



The Evolution Wand is truly the next evolution in wand design and performance. The Aluminum tube and Rotomolded head make it extremely lightweight which helps to reduce fatigue on the technician. The sealed Delrin® glides help the wand to be easily pushed across the carpet, and are tapered to keep a good seal on the fibers.

No other tool has made such a dramatic increase in soil removal and water recovery. The laminar airflow design of the Evolution wand has boosted the performance of some portable extractors from a bronze to a gold level of certification from the Carpet and Rug Institute's Seal of Approval Program for tested cleaning performance. The Evolution will change the way carpets are cleaned.

Available in two sizes: a 12" head with 1-1/2" tube and two jets or a high production 16" head with 2" tube and 6 jets.

Evolution Wands
Half the weight, twice the performance.
The Evolution is not your standard wand.



BOXER 318



1½" HydraHoe Carpet Cleaning Wand

Glides over carpet without chattering! 12" wide head increases production. High temperature, high pressure, stainless steel fabrication, stainless valve, quick coupler and assist handle.

Item #163-020

1½" S-Bend Two Jet Wand

This 12" wide S-Bend wand has two jets. It uses a 1½" tube and glides over the carpet for easy operation.

Item #100-011-106

UT-40 Utility Cleaning Tool

An all purpose tool for cleaning carpeted divider panels, under restaurant booths, landings, stairs and hard to reach carpeted areas. All stainless construction, 9" wide head and 40" long shaft allows operator to "stand-up" when cleaning stairs.

Item #163-008

UT-14 Truckmount Stair Tool

The best stair tool on the market today. This tough stainless steel hand tool is 14" long with 6" wide cleaning head and stainless steel valve with quick coupler, assist handle.

Item #163-009

RX-20® Tool

Before turning on the RX-20, adjust the handle; it should rest right below or even with the bottom of your pants' front pockets, with the tool resting flat on the floor. Take your time in adjusting the tool's height; make sure the head of the tool is flat with the floor while you are holding the handle. Relax your posture; the more difficult it is to hold the tool's head flat on the floor surface, the more quickly you will tire.

While the tool is running, control the left and right movements of the tool by tilting the head to the front and back, and lifting the handles up and pushing the handles down. The tool can be driven to the forward and backward by tilting the head of the unit to the left and right. The head must be turning to use the self driving feature of the tool, and only requires a slight bit of pressure to handles to get the head to move the tool across the floor.

As with the wand, drying times will be improved if you run a dry pass between wet passes. Hold down the solution trigger and move the unit left or right across the floor 3 or 4 ft, then immediately back across the same pass, without the solution flowing, to make the dry pass. Make the next pass half-overlapping the previous pass.

Use the RX-20 in very heavily trafficked areas or if it has been a long time since the carpet has been cleaned. Beware of the seam edges of carpets and transition edges between floor surfaces. Use extreme caution when cleaning these areas.

Sometimes it is necessary to use an edge tool or wand to run the perimeter of the room on in difficult-to-reach areas where the circular head of the rotary units will not reach.

For Truckmount or Portable Carpet Cleaning Systems

- ***Aggressive restorative extractor tool for carpet, hard surface and bonnet cleaning***
- ***Labor-saving, ergonomic design***
- ***Superior agitation for cleaning stains, heavily soiled and matted carpet***
- ***Durable construction for long life***
- ***Reduces fatigue of the operator***



The 5 vacuum heads and 3 jets rotate at 130 rpm, creating 650 complete cleaning passes per minute.

Upholstery Tool - DriMaster 3

Use the upholstery tool on small rugs and furniture. When you clean rugs, be sure that the temperature and chemicals are safe for that particular type of rug.



As with the larger tools, do not leave the surface of the upholstery too wet. Adjust the volume of water on the tool without it touching any surface: the water should just barely come out of the tool before the vacuum pulls it back in. The water will only just spray the top layer of the furniture and the vacuum will pull the dirty water back into the tool.

If you find it necessary to do a dry pass, keep strokes short to limit the amount of water that comes into contact with the fabric surface.

3 - Operating Instructions

START-UP PROCEDURE

1. Perform all daily and periodic maintenance as specified in Section 4 of this Owner's Manual.
2. Connect a garden hose to supply water to the truckmount. If used, turn the "PUMP-IN" switch to the "ON" position (see Figure 3-1).

NOTICE

The water box must be full prior to starting the truckmount.

3. Connect the cleaning tool to the length of hose required to perform the cleaning job.
4. Turn the key to "ON". Pull the choke and start the truckmount with the throttle cable fully depressed ("IDLE" position - see Figure 3-1).
5. After the engine starts, push the choke in and allow the truckmount to run in "IDLE" for 2 - 3 minutes to warm up.
6. Pull the throttle cable to full extension and twist the handle clockwise to lock.



Figure 3-1. Location of Throttle, Choke and Pump-In/Pump Clutch Switch

BOXXER 318



Figure 3-2. Front View of Boxxer 318 Console

7. Press the “PUMP CONTROL” switch to engage the pump clutch for carpet cleaning or upholstery cleaning as follows:
 - a. Switch to the “HP Only” if connected to a fresh water supply from a building.
 - b. Switch to the “HP ON & Pump-In ON” if connected to a fresh water tank.
8. Set the temperature to the desired level on the “TEMPERATURE” knob.
9. If used, turn the “AUTO PUMP-OUT” switch to the “ON” position.
10. Adjust the “PRESSURE REGULATOR”, located on the left hand side of the machine (see Figure 3-3), to the desired cleaning pressure level.

Suggested Settings:

Carpet Cleaning: 300 - 400 psi

Hard Surface Cleaning: 1,000 psi or as indicated on the tool

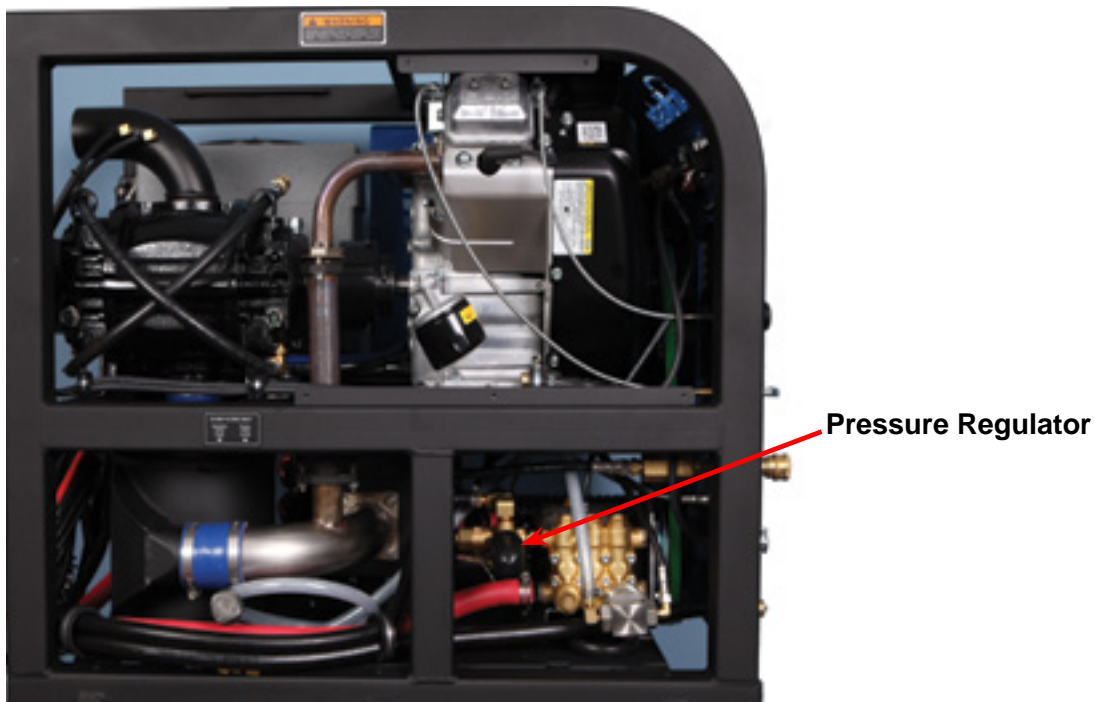

Figure 3-3. Side View of Boxxer 318 Console

11. Turn the “CHEMICAL SELECTION VALVE” to the “PRIME” position to purge any air from the system.
 - a. With the truckmount running at full throttle, block off the vacuum intake to the recovery tank. The vacuum gauge should read 12”-14” Hg. This will assist in priming the chemical system.
 - b. Allow the chemical to flow through the chemical meter at full flow for 30 seconds.
 - c. Turn the “CHEMICAL SELECTION VALVE” to “ON.” The restriction can now be removed from the vacuum inlet.
 - d. While spraying solution from the cleaning tool adjust the chemical flow by turning the “CHEMICAL METERING CONTROL KNOB”.
12. Begin cleaning.

CAUTION

Never perform cleaning operations when the truckmount engine is running at the IDLE throttle position. Failure to follow this caution will increase the risk of serious component or engine damage.

WATER EXTRACTION PROCEDURE

To perform water extraction, set the “PUMP CONTROL” switch to the flood extraction position. This will disengage the pump clutch, allowing for the machine to run without fresh water connected to the machine.

SHUT-DOWN PROCEDURE

1. Flush clean water through the chemical system for 10 seconds. Turn the “CHEMICAL SELECTION VALVE” to “OFF.”
2. Cool the truckmount down by turning the “TEMPERATURE CONTROL” dial to the lowest position (counter-clockwise). Spray the cleaning wand into the vacuum hose for 3 - 5 minutes. The chemical is now flushed from the truckmount, hoses and cleaning tool.
3. Remove the vacuum hose.
4. Lubricate the blower to prevent it from rusting internally.
 - a. Allow the unit to run for a few minutes with the vacuum hose disconnected in order to remove moisture from the blower.
 - b. Cap off the inlet(s) to the vacuum tank.
 - c. Spray a HydraMaster-recommended spray lubricant into the “BLOWER LUBE PORT” for about 5 to 7 seconds while the unit is running (see Figure 3-2).
 - d. Allow machine to run additional 2 to 5 minutes under load to flush off lubricant.
 - e. Uncap the inlet(s) and run the unit for another minute to allow the blower to cool down.
5. If freeze guarding is necessary perform the procedure at this time. See Section 4 of the Freeze Guarding section in the Owner’s Manual.
6. Return the engine throttle to the “IDLE” position.
7. Turn the key to “OFF.”
8. Drain the water box using the valve.
9. Drain the vacuum tank in an appropriate location.

NOTICE

In accordance with the EPA, state and local laws, do not dispose of water into gutters, storm drains, streams, reservoirs, etc.

10. Perform daily maintenance as specified in Section 4 of this Owner’s Manual.

4 - Machine Maintenance

To avoid costly repairs and down-time, it is imperative to develop and practice good maintenance procedures from the beginning. These procedures fall into daily, weekly, monthly and quarterly increments, and are outlined in this section. All recommended maintenance must be performed by competent service personnel.

This section covers:

- Operational Maintenance
- Overall Machine Maintenance
- High Pressure Pump Maintenance
- Vacuum System Maintenance
- Descaling Procedure (Required)
- Freeze Guarding
- Tensioning the Pump Drive Belt

NOTICE

Record the date and machine hours on the maintenance log provided for your convenience in the Owner's Guide. Records of maintenance must be kept and copies may be required to be furnished to HydraMaster before the warranty is honored. It is recommended that you affix a copy of the log on the vehicle door near your unit for convenience and to serve as a maintenance reminder.

OPERATIONAL MAINTENANCE

Daily Maintenance

- Check the engine oil level. Add oil if needed.
- Check the high pressure pump oil. Add oil if needed.
- Inspect and clean the recovery tank filters.
- Inspect and clean the orifices and filters.
- Inspect and clean the garden hose screen.
- Inspect the truckmount for water and oil leaks, loose electrical connections, etc. and repair as needed.
- Lubricate the blower lube port with HydraMaster-recommended spray lubricant.

Weekly Maintenance

- Inspect the recovery tank filters for tears, holes, etc. Repair or replace as needed.
- Inspect the vacuum relief valve. Clean and lubricate as necessary.
- Clean the recovery tank thoroughly with pressure washer.
- Check the oil level in the blower. Add oil if needed.
- Check the pump drive belt for wear and proper tension. Tighten as needed.
- Check all the hoses and wiring for wear and chafing. Secure as needed.
- Flush the water and chemical systems with solution of equal parts white vinegar and water.
- Check all the nuts and bolts. Tighten as needed.
- One time change of the high pressure pump oil after 50 hours of operation. (Every 500 hours thereafter.)
- One time change of the engine oil after 8 hours of operation.
- Change the engine oil every 50 hours. (Every 25 hours if operating in high ambient temperatures or heavy use conditions.) Change oil filter every oil change.

Monthly Maintenance

- Check the engine air filter. Clean or replace as necessary.
- Check the water level in battery. Fill as needed.
- Clean the battery terminals as needed.
- Change the blower oil after first 100 hours of use.

Quarterly Maintenance

- Check the fuel lines. Repair or replace as needed.
- Clean and gap the spark plugs to 0.030". Replace if excessive carbon buildup is visible.
- Change the fuel filter.
- Change pump drive belt.

100 Hours

- Replace spark plugs

250 Hours

- Check coupler element (rubber insert) for cracks or wear. Replace as necessary.

500 Hours

- Change the blower oil.
- Change the high pressure pump oil.
- Check the engine valve clearance (intake and exhaust 0.004" - 0.006")
- Change the fuel filter.
- Check coupler element (rubber insert) for cracks or wear. Replace as necessary.

1000 Hours

- Change air filters.
- Check plug wires. Replace as necessary.
- Check carburetor. Clean or replace as necessary.
- Clean the heat exchanger core.
- Replace coupler element (rubber insert) for cracks or wear.

NOTICE

Refer to the Interval Hours Maintenance chart in the Owner's Guide.

HIGH PRESSURE PUMP MAINTENANCE

Daily

Check the oil level and the condition of the oil. The oil level should be up to the center of the sight glass on the rear of the pump or between the “MIN” and “MAX” lines on the dipstick. The dipstick may be found by removing the oil cap.

Periodically

Change the oil after the initial 50 hours of operation and every 500 hours after that. It may be necessary to replace the pump seals and check valves at 500 hours if the truckmount has been running in high ambient temperatures.

CAUTION

If the oil becomes discolored or contaminated one of the oil seals may be damaged. Do not operate the pump if the crankcase oil has become contaminated. Do not rotate the drive shaft without oil in the crankcase reservoir.

CAUTION

The pump should never be run dry. Running the pump dry will cause premature wear on the seals, packing and plungers. Running the pump dry for a prolonged period of time may cause damage that cannot be repaired and voids warranty.

CAUTION

Do not run the pump with frozen water in the manifold. If there is a risk of freezing, freeze guard the truckmount. See page 4-10 of this section for freeze guarding information.

Service

The next few pages explain how to disassemble and inspect all user serviceable parts of the pump.

CAUTION

Do not disassemble the pump unless you are a skilled mechanic. For assistance, contact your distributor.

Valve Maintenance (See Figure 4-1)

1. Using a 22-mm wrench or socket, remove all six valve caps on the manifold of the pump.
2. Examine each valve cap O-ring for cuts or distortions and replace if worn.
3. Using needle nose pliers, remove the suction and delivery check valves. The valve assembly usually stays together when removing. If the valve comes apart, use the needle nose pliers or reverse pliers to remove the remaining parts.
4. Inspect each suction and delivery check valve assembly for wear and pitting, and replace if necessary. The valve assembly consists of the plastic cage, spring, valve seat, poppet and O-ring. One valve kit is needed for complete valve change of one pump.

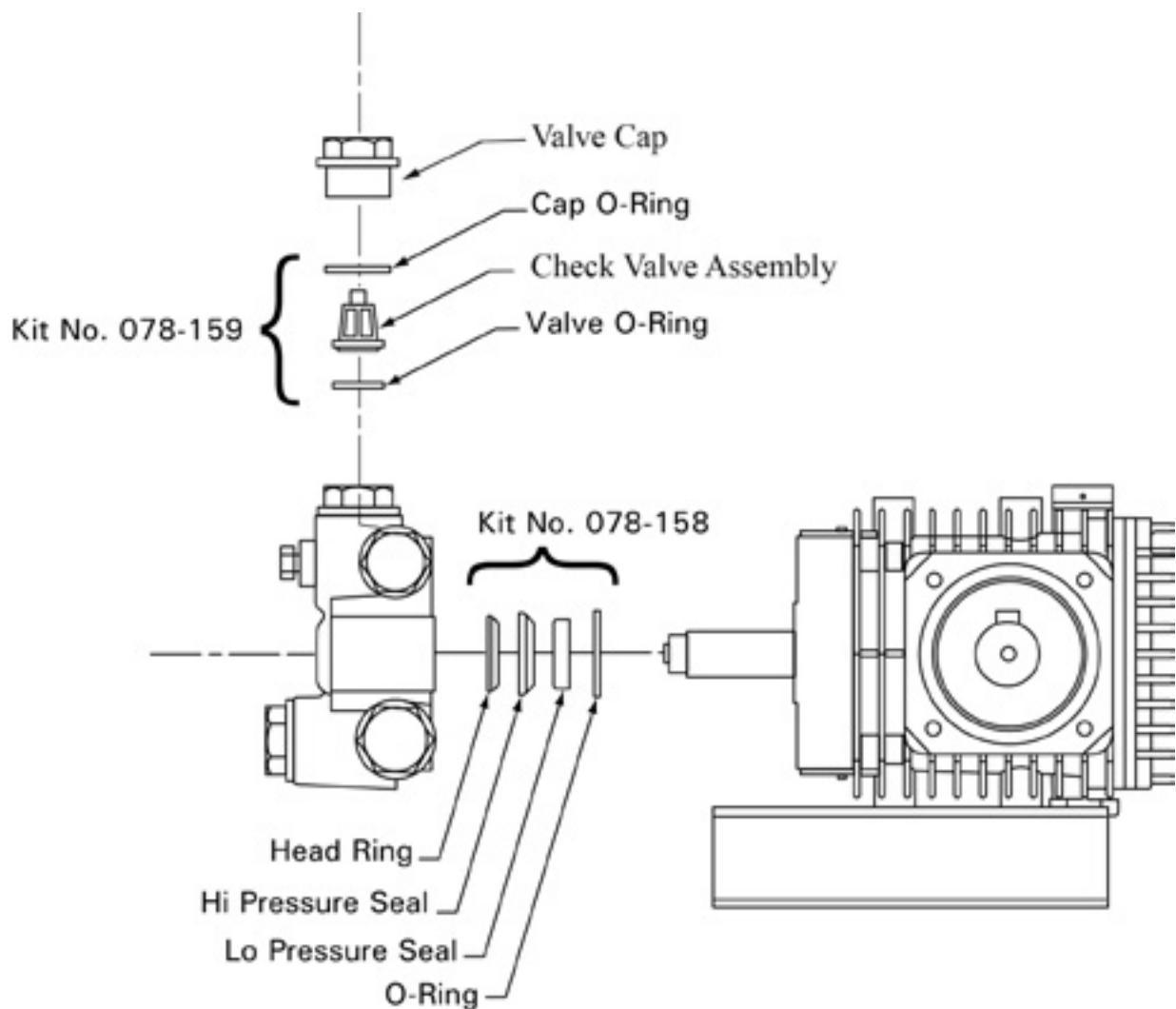

Figure 4-1. Servicing the Valves

BOXXER 318

5. Replace old valves with new valves by placing the assembly in the valve chamber. Press down firmly on the top of the valve assembly.
6. Replace valve caps by applying LOCTITE® 243 to valve cap and torque to 33 ft-lbs.

Removing and Replacing Pump Manifold

1. Remove the manifold of the pump by taking a 5-mm Allen head wrench and removing the eight head bolts.
2. With the pump firmly secured, take a medium sized flat head screwdriver and apply pressure to the manifold by prying between the crankcase and manifold. Work around from all sides of the manifold evenly until it comes off of the pistons. Keep the manifold properly aligned with the pistons to prevent damage to the seals and pistons.
3. When replacing the manifold, turn the crankshaft of pump until the top of the pistons are closely aligned. Lubricate the pistons and cylinders with grease and evenly press the manifold toward crankcase until flush.

Seals and V-Packing Maintenance

1. Remove the manifold as previously described. It is possible that the seal and brass retainer ring assembly will stay on the piston or will remain in the manifold when removing it.
2. Carefully remove the brass retainer ring/seal stack. Remove the low-pressure seal using needle nose pliers. Discard the old seal.
3. Remove the outer O-ring by taking a small flat head screwdriver and working it under the O-ring. Simply roll off the old O-ring and discard.
4. The old V-packing stack can be taken apart by hand and discarded.

Seals and V-Packing Reassembly

1. Generously lubricate parts with grease when reassembling. Examine all brass components for any damage or water residue build-up. Clean or replace as needed.
2. Insert a new low pressure seal by working it in by hand.
3. Install the new outer O-ring by simply starting on one side and working it into the groove.
4. Stack the new V-packing in the correct order and firmly press the assembly into the manifold.
5. Install a new low pressure oil seal by laying the seal into the opening and evenly pressing it into place.
6. Re-install the manifold onto the pump as previously described.

Plunger Maintenance

1. Remove the manifold as previously described. Remove the packing retainers if they remain on the pistons after removing the manifold.
2. Remove the nut and washer on the end of the piston using a 13-mm wrench or socket.
3. Slide the ceramic plunger and the remaining washer from the piston guide. Inspect the ceramic piston, O-ring and washers for wear. Replace if necessary.

Plunger Re-assembly

1. Generously grease the piston guide. Replace the O-ring making sure it does not twist or roll.
2. Slide the lower washer and ceramic bushing onto the piston guide.
3. Place a small amount of LOCTITE 243™ on the piston guide threads. Replace the old washer and thread the nut onto the piston guide. Torque to 4.5 ft-lbs.

Servicing the Crankcase

1. While the manifold and plungers are removed, rotate the crankshaft by hand. Closely examine the crankcase oil seals for drying, cracking or leaking.
2. Consult the local HydraMaster distributor if crankcase servicing is necessary.

VACUUM SYSTEM MAINTENANCE

The vacuum pump in this machine is commonly referred to as a “rotary positive displacement blower” or “blower” for short. The performance and life of the truckmount is greatly dependent on the care and proper maintenance it receives. Review the blower’s owner’s manual, which has been included, for a better understanding of this piece of machinery.

To protect the blower from overloading and damaging itself, a vacuum relief system is installed on the recovery tank. When the recovery tank inlet is completely sealed off, a maximum of 12” Hg will be attained.

CAUTION

Solid objects entering the blower will cause serious damage to the internal components of the blower. Extreme caution should be used when the truckmount is being run for test purposes with the inlet to the blower open to the atmosphere.

CAUTION

Foam passing through the blower can lead to serious problems with the truckmount. It is important to keep the recovery tank free of foam. The tank is protected from overflowing by a float kill switch; however, this switch is not activated by foam.

Daily

At the end of each day the internal components of the blower need to be lubricated. This helps to prevent rust deposits and prolongs the life of the truckmount.

Lubricate the blower to prevent it from rusting internally by:

1. Allowing the unit to run for a few minutes with the vacuum hose disconnected in order to remove moisture from the blower.
2. Capping off the inlet(s) to the recovery tank.
3. Spraying a HydraMaster-recommended spray lubricant into the “BLOWER LUBE PORT” for about 5 to 7 seconds while the unit is running.
4. Uncapping the inlet(s) and run the unit for another minute to allow the blower to cool down.

Periodically

Change the oil in both ends of the blower after the initial 100 hours of use. Change the oil each 500 hours of use thereafter.

DESCALING PROCEDURE (REQUIRED)

Scale deposits on the interior of the heating system can cause a noticeable loss in heating performance. Deposits of this kind result from hard water deposits. The frequency with which descaling procedures are required will vary. If the area has particularly hard water, you may have to descale often.

To descale the system, add an appropriate descaler chemical to the water box. Circulate it through the system. Let it stand. Flush and repeat as necessary. Clean all screens and strainers, and check them frequently following descaling.

NOTICE

If using TM DeScaler™ through the flow meter, make sure to run clean water through the flow meter after this procedure.

To descale using the recirculation kit (P/N 000-078-058), start with an empty water box.

1. Fill a third of the water box with TM DeScaler. Follow the recommendations on the TM DeScaler label for proportions. Verify that the float is not lying horizontal, but floats below.
2. Attach the recirculation fitting provided in the kit to the garden hose quick connect (see Figure 4-2) and this combination to the front of the truckmount.
3. Attach one section of the solution hose to the outgoing solution fitting on the front of the truckmount and the other end to the garden hose and recirculation fitting combination that is attached to the front of the truckmount. Additional hoses may be attached inline if descaling of hoses is needed.
4. Start the truckmount and allow it to run for 3 - 5 minutes. Do not leave the TM DeScaler solution in the system. Flush the system with clean water and turn the truckmount OFF.

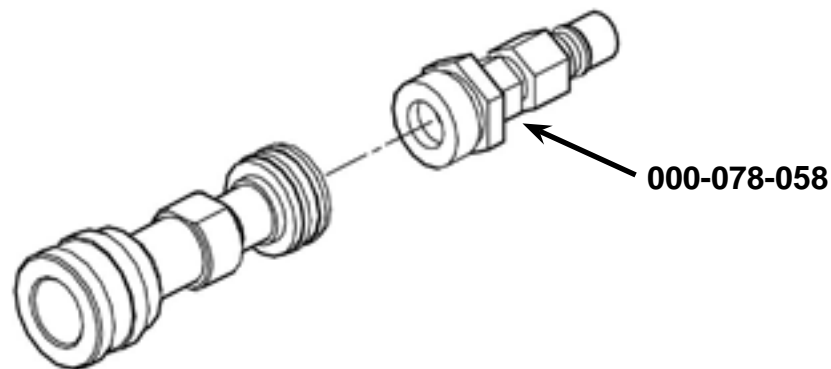

Figure 4-2. Recirculation Fitting

FREEZE GUARDING

To avoid permanent damage to the truckmount, it is imperative to follow the freeze guard procedure whenever the possibility of freezing temperatures exists.

CAUTION

When disposing of antifreeze follow local laws and regulations. Do not discard into storm sewers, septic systems, or onto the ground.

⚠ WARNING

Antifreeze is harmful or fatal if swallowed. Do not store in open or unlabeled containers. Keep out of reach of children and animals.

Freeze Guard Procedure

1. With the truckmount turned off and the incoming water line disconnected, open the water box drain valve on the front of the truckmount. Allow the system to fully drain.
2. Add 2 gallons of 50/50 antifreeze and water mix to the water box.
3. Attach a section of solution hose to the outgoing solution fitting on the front of the machine. Attach the opposite end to the recirculation fitting. (If more sections of hose are to be freeze guarded attach those inline.)
4. Start the truckmount and allow it to run for 2 to 3 minutes. This will distribute antifreeze solution throughout the truckmount.
5. Remove the chemical feed line from the chemical jug. Turn the selector valve to "PRIME." This will vacuum the chemical remaining in the lines to the recovery tank.

NOTICE

If using the recirculation kit, skip ahead to step 7.

6. Remove the quick connect from the truckmount.
7. Spray the antifreeze and water mix out of the truckmount and into a container to reclaim the solution. Run the truckmount until there is no more solution coming from the truckmount.
8. The truckmount is now freeze guarded. Remember to flush antifreeze from the system prior to carpet cleaning. See the following procedure.

NOTICE

The reclaimed antifreeze solution may be used three times before being discarded.

NOTICE

To freeze guard the hoses and wand perform step 7 with the items to be freeze guarded attached.

Recovering Antifreeze for Re-Use

1. Attach all hoses and wands which have been freeze guarded to the truckmount.
2. Attach the incoming water source to the front of the truckmount.
3. Start the truckmount.
4. Spray the solution through the hoses and wands into a sealable container until all signs of antifreeze are gone.

Freeze Protection of the Pump-In System

1. Drain the fresh water tank.
2. Remove the garden hose adapter from the pump-in pump hose and position the hose so it is pointing outside the van.
3. Turn on the pump-in pump and run for 1-2 minutes until all the water is purged from the hose.

NOTICE

The next time the truckmount is used it may take a few minutes before the water box begins to fill.

TENSIONING THE PUMP DRIVE BELT

1. Remove the Boxxer 318 grill to gain access to the idler pulley.
2. Loosen but **do not remove** the 2 ¼" long bolt (P/N 000-143-041) on the idler pulley. See Section 9 in the Owner's Manual.
3. Remove the right cover of the machine to gain access to the tensioning screw.
4. Adjust the tension of the belt by turning the 4" long screw (P/N 000-143-376).
5. After the proper belt tension is achieved, tighten the ½" bolt on the idler pulley.

CAUTION

Ensure there is no contact between idler assembly (including belt) and no other part of the truckmount. Contact between the parts could result in damage to the truckmount.

6. Replace the right cover and grill.

5 - Water and Chemical System

This section describes the water and chemical systems in the following areas:

- Water and Chemical Flow Operation
- Water and Chemical Flow Diagrams

WATER AND CHEMICAL FLOW OPERATION

Fresh water is brought through the front of the truckmount into the water box. The level of water in the box is maintained by the use of a float valve. The water is then gravity fed to the pump where it is pressurized.

Next, the pressurized water enters the by-pass valve. This valve allows manual adjustment of the pressure level. When the valve at the wand is closed, nearly all of the water in the system is recirculated to the water box at this point. When solution is being used at the wand the necessary amount of high pressure water passes through the by-pass valve and to the heat exchanger.

The pressurized water then travels to the exhaust heat exchanger. In the finned tube heat exchanger, the temperature of the water is raised to the selected cleaning temperature. The heat necessary to do this is provided by both the engine and blower exhausts. The heated water finally travels to the high pressure manifold.

The high pressure manifold houses both the temperature sensor for the heat control system and a high temperature shutdown switch. There is an orifice located in the manifold, referred to as a recirculation (or primary) orifice which allows a small amount of high pressure, high temperature water to pass back to the water box. This prevents excessive pressure building up in the heat exchanger when the wand valve is closed and no solution is exiting the truckmount.

The water that is being called for by the wand then exits the manifold and passes through a check valve. Finally, the water joins the chemical where the solution is created.

The chemical is pressurized by the HydraMaster diaphragm chemical pump attached to the head of the water pump. This pump pulls the chemical from the jug through the chemical meter. After being pressurized, the chemical travels through the metering valve and is injected into the high pressure stream. This solution then exits the front of the truckmount and is delivered to the cleaning tool.

BOXER 318

Figure 5-1. Flow Diagram - View 1 of 3
000-179-038 Rev. C

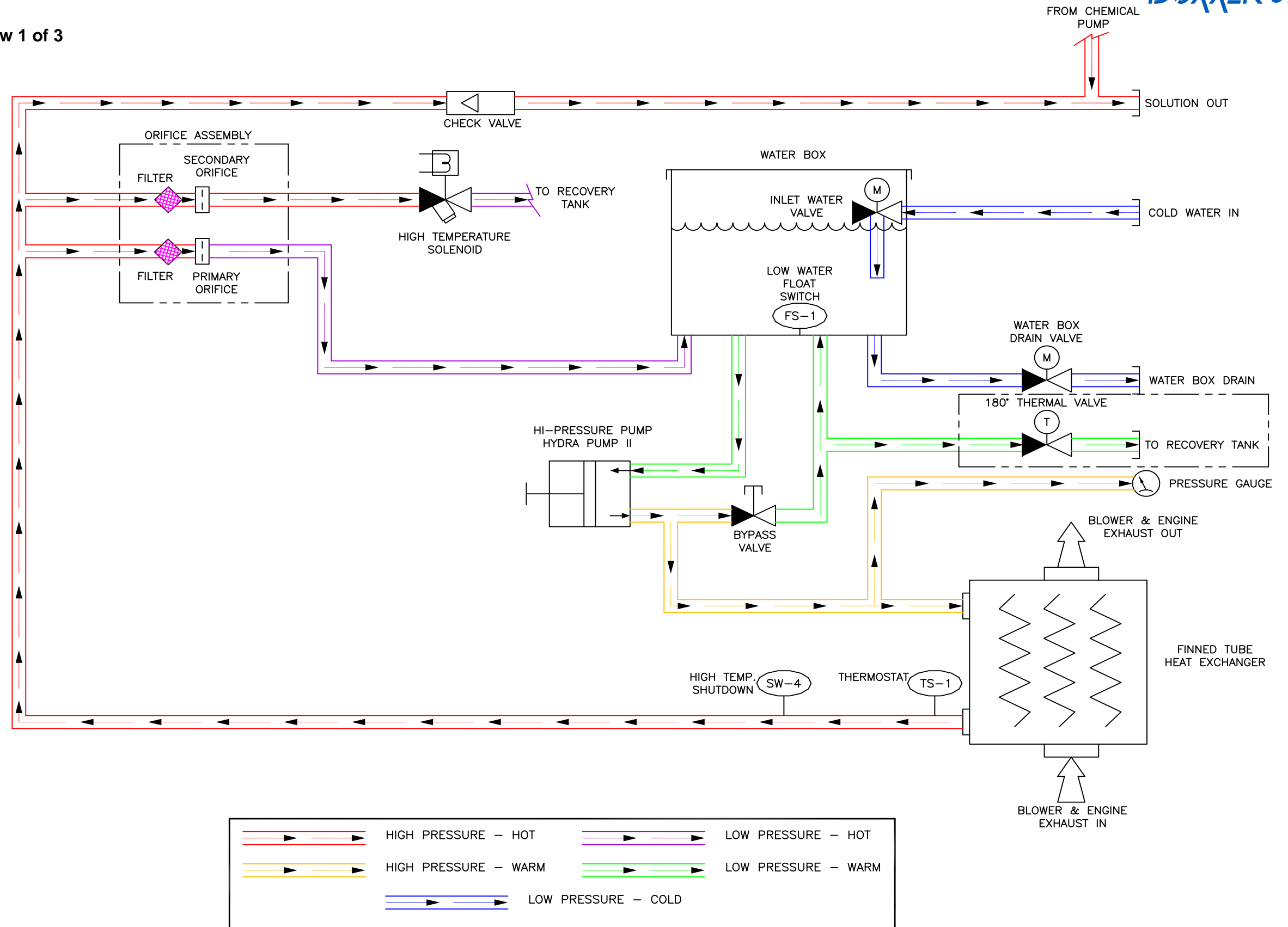

BOXER 318

Figure 5-2. Flow Diagram - View 2 of 3
000-179-038 Rev. C

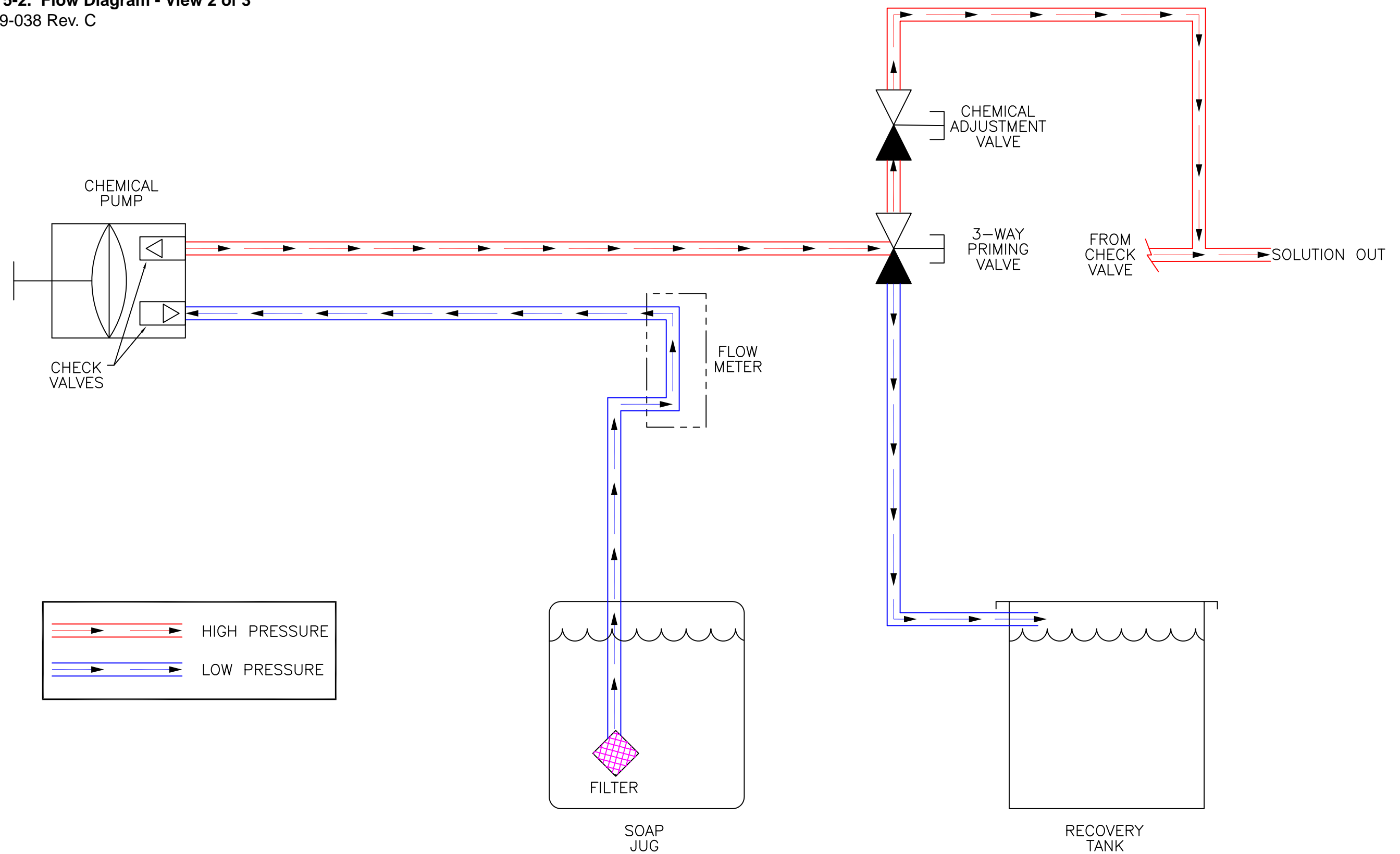
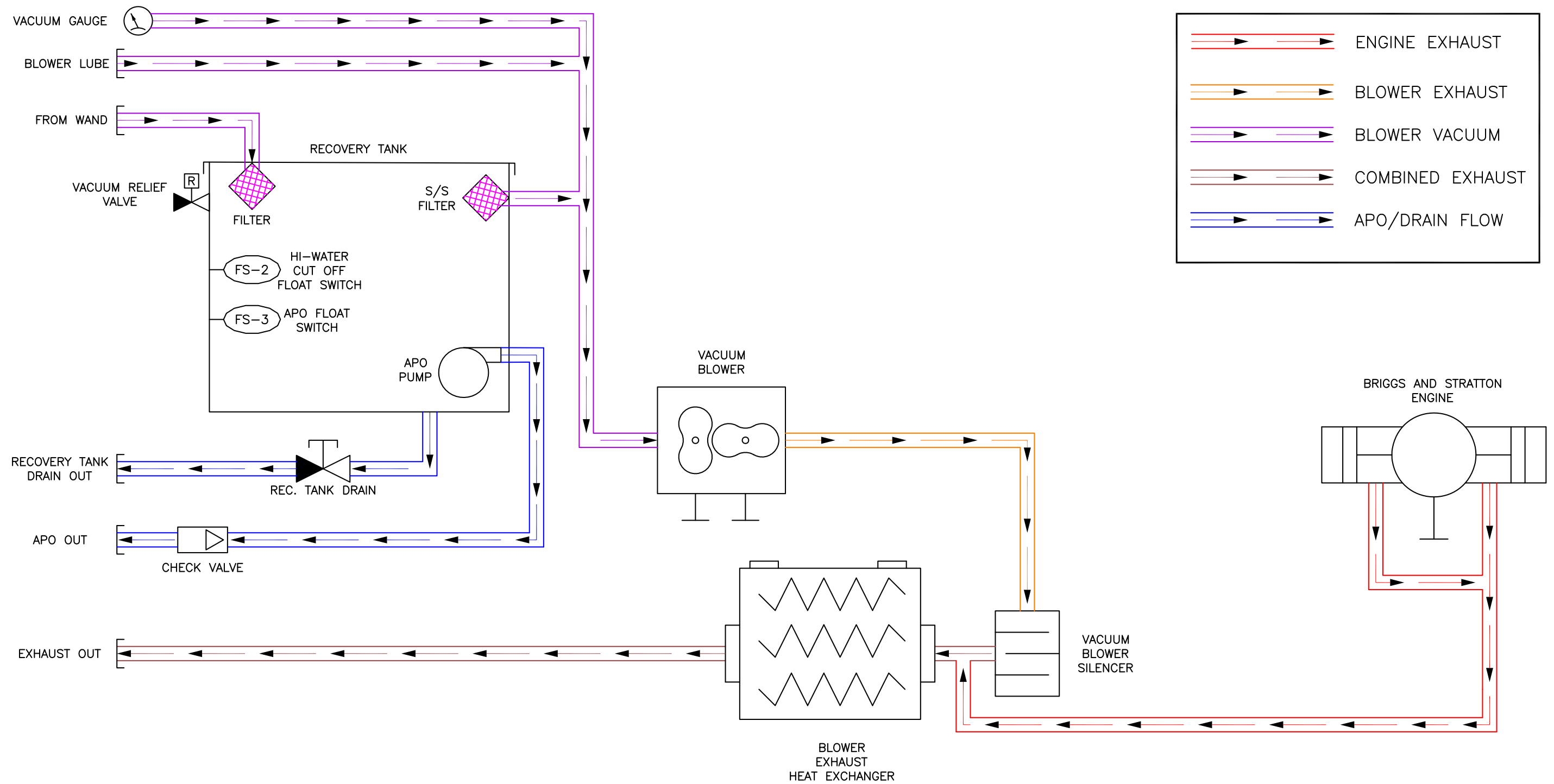

Figure 5-3. Flow Diagram - View 3 of 3
000-179-038 Rev. C



BOXER 318

6 - Electrical System

This section describes how the electrical system functions in the following manner:

- Electrical System Information
- Electrical Schematic
- Wiring Diagram

The Boxxer 318 electrical system operates on 12 V DC which is provided by the battery. Battery levels are maintained by a 20 Amp alternator that is built into the engine.

NOTICE

When a new battery is installed, check that it is properly charged before installation or damage to the charging system may occur.

BOXER 318

Figure 6-1. Electrical Schematic
000-179-048 Rev. A

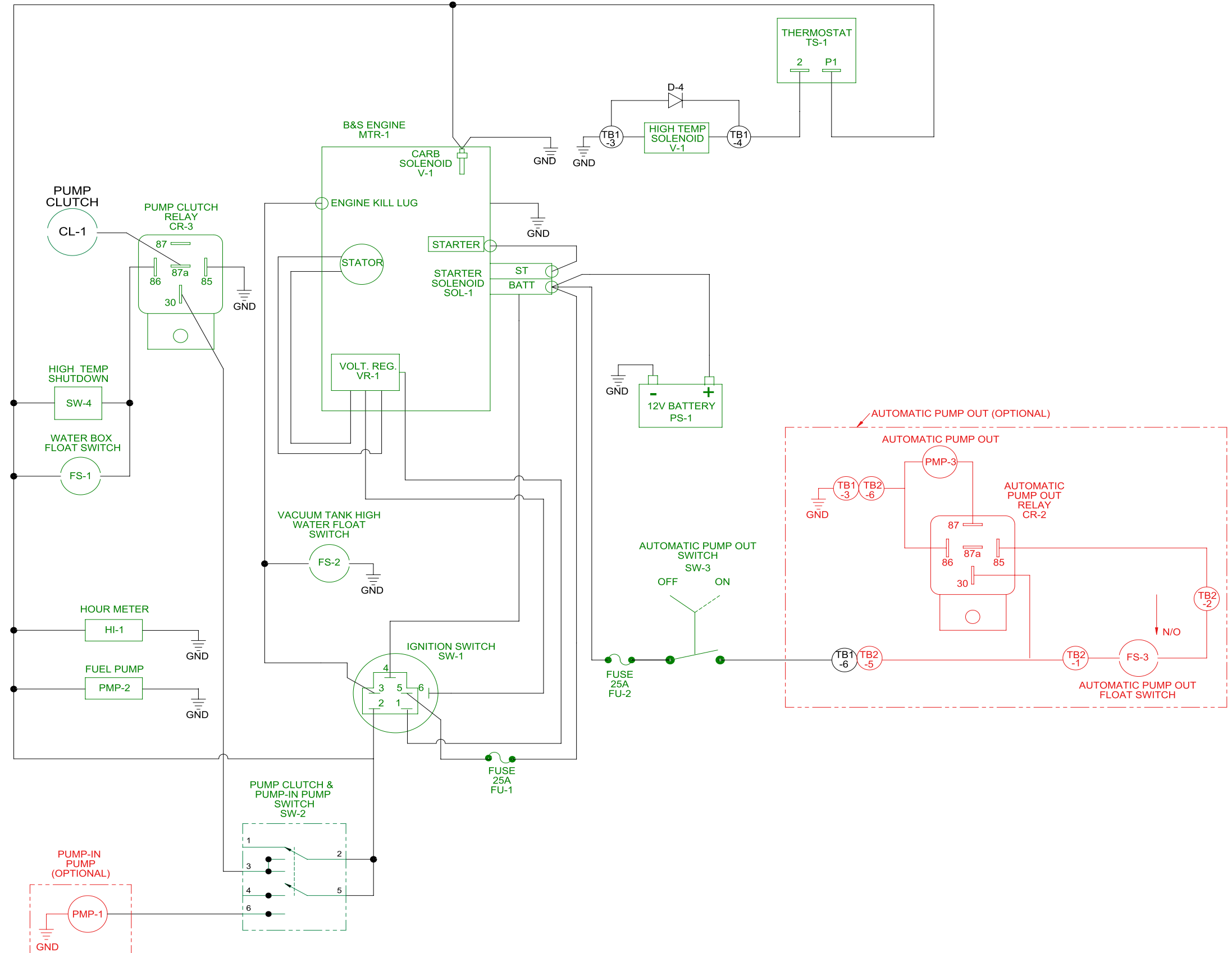
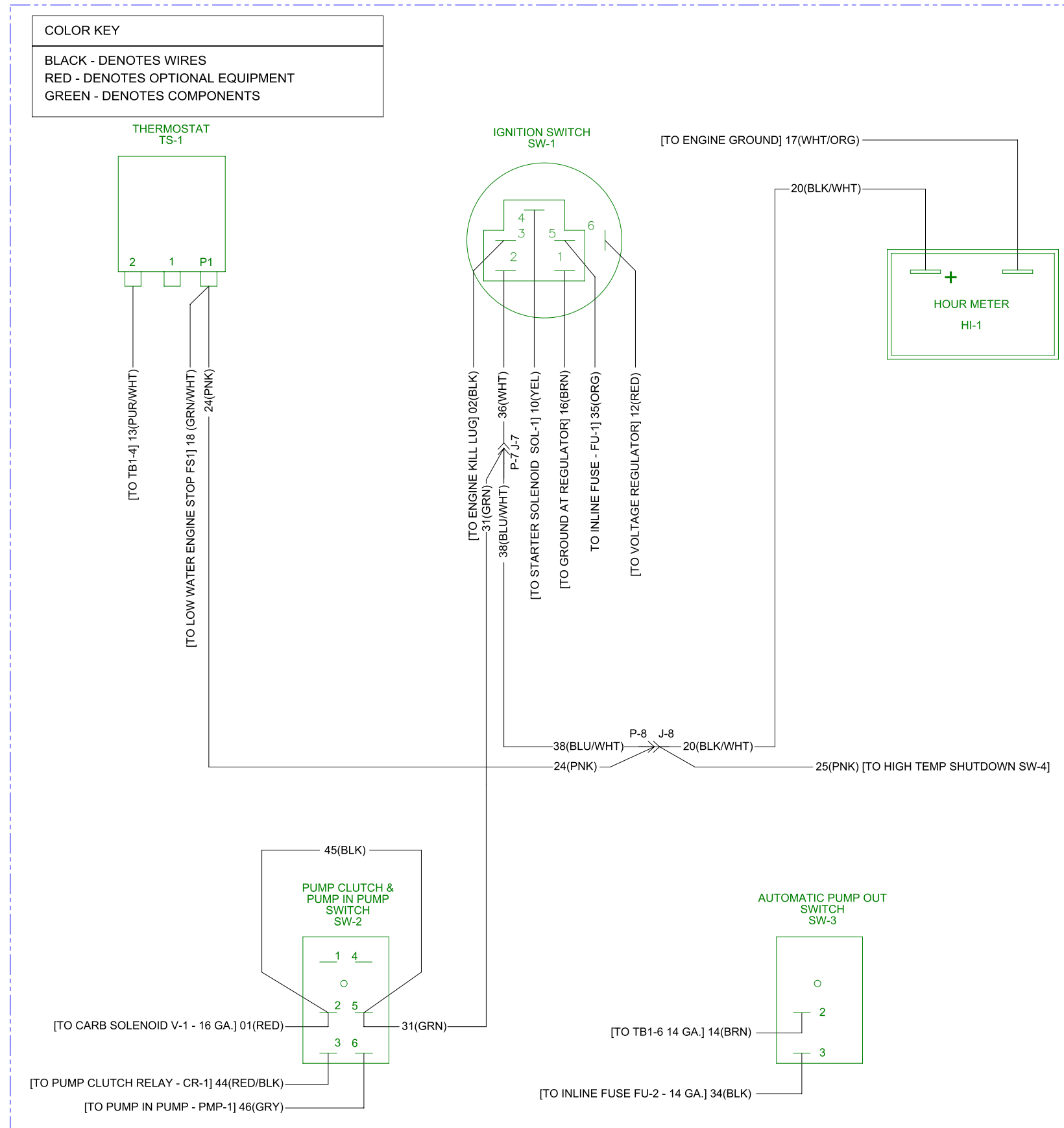

Figure 6-2. Wiring Diagram -
View 1 of 2
000-179-047 Rev. A



*ALL WIRES ARE 18 GAUGE UNLESS OTHERWISE STATED

BOXER 318

Figure 6-3. Wiring Diagram - View 2 of 2
000-179-047 Rev. A

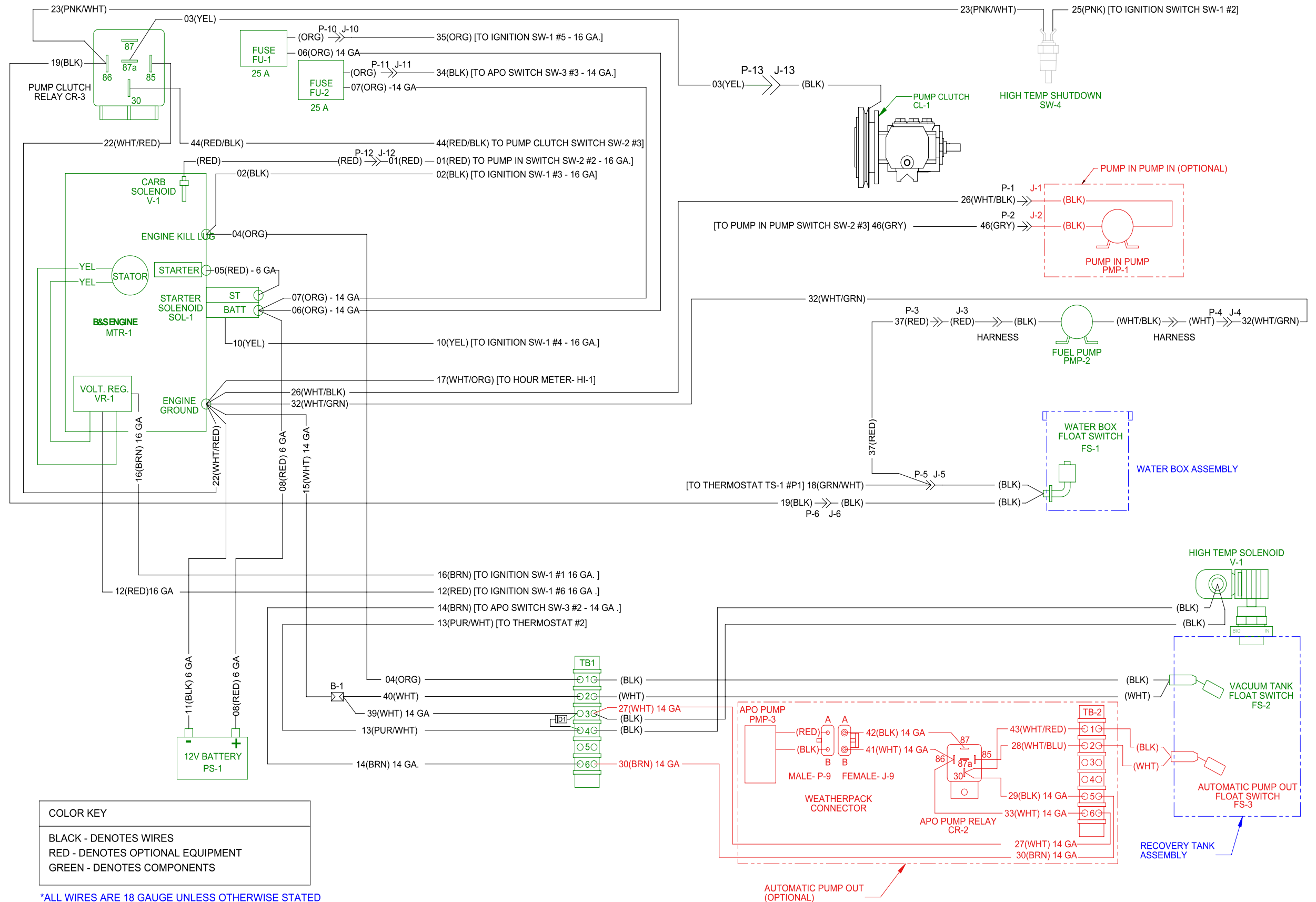

BOXER 318

7 - Troubleshooting

This section describes the standard troubleshooting procedures in the following areas:

- Heating System
- Chemical System
- Engine
- High Pressure System
- Vacuum System

HEATING SYSTEM

1.0 Truckmount overheats and shuts down

	Possible Cause	Solution
1.1	The orifice or filter screen are restricted.	Remove and inspect. Clean as necessary.
1.2	The high pressure dump solenoid is restricted.	Inspect the solenoid and the hose that delivers water to it. Clean or replace as necessary.
1.3	The dump solenoid is faulty.	Check the main fuse. If the fuse is blown, inspect electrical system for worn or shorted wires. Repair or replace as necessary.
		Inspect the solenoid and test for functionality. If the solenoid is operable, refer to a qualified service technician to test the temperature controller and sensor.

2.0 Unable to achieve normal cleaning solution temperature

	Possible Cause	Solution
2.1	Temperature control knob is turned down.	Inspect the knob. Adjust if necessary.
2.2	The dump solenoid is faulty.	Inspect the solenoid and test for functionality. If the solenoid is operable, refer to a qualified service technician to test the temperature controller and sensor.
2.3	Excessive solution flow at tool.	The cleaning tool jet is too large or worn. Inspect the jet. Replace if necessary.
2.4	The heat exchanger has hard water scale buildup.	Descale the system.
2.5	The heat exchanger has blockage on the exhaust side.	Inspect the interior of heat exchanger. Remove the debris and clean as necessary.

CHEMICAL SYSTEM

1.0 System will not prime

	Possible Cause	Solution
1.1	The check valves in chemical pump are faulty.	Remove the valves and inspect. Clean or replace as necessary.
1.2	The chemical pump diaphragm is faulty.	Remove and inspect. Replace as necessary.
1.3	The check valve in high pressure pump is faulty (piston which chemical pump is attached to).	Remove the valve and inspect. Clean or replace as necessary.
1.4	The filter on feed line in chemical jug is clogged.	Inspect and clean.
1.5	The feed line from chemical jug is loose, pinched or damaged.	Inspect and repair.
1.6	The chemical selector valve is faulty.	Inspect the valve for leaks between ports. Replace as necessary.

2.0 Chemical flow is unstable or low

	Possible Cause	Solution
2.1	Air is in the lines.	Check that all fittings and connections are tight and in good condition. Repair or replace as necessary.
2.2	The check valve in high pressure pump is faulty (piston which chemical pump is attached to).	Remove the valve and inspect. Clean or replace as necessary.
2.3	The filter screen in the chemical jug is partially obstructed.	Inspect and clean.
2.4	The chemical selector valve is faulty.	Inspect the valve for leaks between ports. Replace as necessary.
2.5	The chemical metering valve is faulty.	Remove and inspect the valve. Clean or replace as necessary.
2.5	The high pressure check valve is faulty.	Remove and inspect the valve. Clean or rebuild as necessary.

3.0 Chemical is present in water box

	Possible Cause	Solution
3.1	The chemical pump diaphragm is faulty.	Remove and inspect the chemical pump diaphragm. Replace as necessary.
3.2	The high pressure check valve is faulty.	Remove and inspect the valve. Clean or rebuild as necessary.

ENGINE

1.0 Will not turn over

	Possible Cause	Solution
1.1	A loose or corroded battery terminal.	Clean and tighten the battery terminal connections.
1.2	The battery is dead.	Recharge or replace the battery. Test the charging system. Repair if necessary. <div style="background-color: yellow; text-align: center; padding: 5px;">CAUTION</div> <p>Do not attempt to jump start the truckmount from a running vehicle. The amperage output from an automobile will damage the charging system of the truckmount.</p>
1.3	The main fuse is blown.	Check the main fuse.
		If the fuse is blown, inspect the electrical system for worn or shorted wires. Repair or replace as necessary.
1.4	The vacuum blower has seized.	Attempt to turn the coupler by hand. If it will not turn refer to the Vacuum System Troubleshooting Section.
1.5	The ignition switch is faulty.	Test to see if there is power both to and from the switch. Refer to the Electrical Section.
1.6	The starter solenoid is faulty.	Test to see if there is power to solenoid with ignition in "Start" position. Refer to Electrical Section.
1.7	The starter motor is faulty.	Test to see if there is power to the motor with the ignition in "Start" position. Refer to the Electrical Section.
1.8	None of the above.	Refer to a qualified service technician for further troubleshooting.

2.0 Turns over but will not start. there is no spark. (To check for spark, refer to engine manual.)

	Possible Cause	Solution
2.1	The recovery tank is full.	Drain the tank.
2.2	The recovery tank float is faulty.	Inspect the float. Repair or replace as necessary.
2.3	The engine ignition system is faulty.	Refer to a qualified service technician for further troubleshooting.

3.0 Turns over but will not start; there is spark. (To check for spark, refer to engine manual.)

	Possible Cause	Solution
3.1	Fuel is not reaching the carburetor.	Test for power to the fuel pump. Refer to Electrical Section.
		If power is present, inspect the fuel pump. Replace if necessary.
		Inspect the fuel lines between the source and the carburetor. Repair or replace as necessary.
3.2	The carburetor solenoid is faulty.	Test for power to the solenoid. Refer to Electrical Section.
		If power is present, inspect the solenoid. Replace if necessary.
3.3	The engine is flooded.	Pull the throttle cable completely and crank until the engine starts.
3.4	The spark plugs are worn or dirty.	Inspect and replace as necessary.
3.5	None of the above.	Refer to a qualified service technician for further troubleshooting.

4.0 Will not come up to normal operating rpm (Engine should be adjusted to run at 3,150 rpm under a vacuum load of 0" Hg.)

	Possible Cause	Solution
4.1	The throttle linkage is out of adjustment.	Inspect for broken or loose linkage. Repair or replace as necessary.
4.2	Excessive load on the engine.	Inspect and clean the recovery tank filters.
		Inspect the recovery tank to the blower hose. Repair or replace as necessary.
4.3	Excessive back pressure on the engine exhaust.	Inspect for blockage in the heat exchanger. Clean or replace as necessary.

5.0 Runs rough at high speed

	Possible Cause	Solution
5.1	The spark plug(s) are faulty.	Remove and inspect the plugs. Clean or replace as necessary.
5.2	The spark plug wire(s) are faulty.	Inspect the wires and connectors for damage or loose connections. Repair or replace as necessary.
5.3	Inadequate fuel supply to the carburetor.	Check if the fuel pump is mounted in a vertical position near the fuel source. Correct if necessary.
		Check for blockage in the filter. Repair or replace as necessary.
		If operating altitudes have changed, contact your distributor to have the engine carburetor jets checked.

6.0 Runs rich.(Black smoke)

	Possible Cause	Solution
6.1	The air filter is dirty.	Inspect and replace as necessary.
6.2	The choke is partially closed.	Inspect and adjust or repair as necessary.
6.3	Excessive fuel to the carburetor.	Check to see if the proper fuel pump is installed.
		If operating altitudes have changed, contact your distributor to have the engine carburetor jets checked.

7.0 Engine overheats

	Possible Cause	Solution
7.1	Poor ventilation in the van.	Open all the van doors. Install a roof vent in the van.
		Remove any dividers or other objects impeding airflow around the truckmount.
7.2	Low oil level.	Check the level and fill as necessary. CAUTION Running the engine with a low oil level can cause severe damage to the engine. If this situation occurs, the engine should be inspected by a qualified service technician.
7.3	The engine rpm is too high.	Check the engine rpm. Adjust as necessary to run at 3,150 rpm under a vacuum load of 0" Hg.
7.4	Excessive back pressure on the engine exhaust.	Inspect for blockage in the heat exchanger. Clean or replace as necessary.

HIGH PRESSURE SYSTEM

1.0 The pump will not come up to normal cleaning pressure

	Possible Cause	Solution
1.1	The pressure adjusting valve is faulty.	Inspect the valve. Repair or replace if necessary.
1.2	Worn seals or valves in the pump.	Test the pump output volume directly from the pump at normal running rpm. If the volume is below the manufacturer's specifications, replace the seals and inspect for defective valves.
1.3	The pump rpm is too low.	Check for a loose pump belt. Adjust or replace as necessary.
		Check the engine rpm and adjust as necessary to 3,150 rpm under a 0" Hg vacuum load.
1.4	The primary orifice is missing or loose.	Remove and inspect. Tighten or replace as necessary.
1.5	The primary and secondary orifices have been installed incorrectly.	Inspect and reverse if necessary. Refer to the Machine Assemblies & Parts List Section.
1.6	The primary orifice is worn.	Measure the orifice size and replace as necessary. Correct size is 0.039".

2.0 No pressure reading on gauge

	Possible Cause	Solution
2.1	The pump belt is broken.	Inspect and replace if necessary.
2.2	The gauge is faulty.	Replace the gauge.
2.3	Water box is empty.	Fill the water box.
2.4	Water box switch is faulty.	Replace water box switch.

3.0 The psi gauge reads normal; low pressure from wand

	Possible Cause	Solution
3.1	Restriction in the cleaning tool.	Inspect the tool jet(s) and clean or replace as necessary.
		Inspect any filters in the cleaning tool and clean or replace as necessary.
3.2	Faulty quick connect in the system.	Inspect each quick connect and replace as necessary.
3.3	Restriction in one of the solution hoses.	Remove the quick connects and inspect hoses. Clean or replace as necessary.
3.4	Hard water deposits restricting the system.	Descale the truckmount.

4.0 Pressure pulsation

	Possible Cause	Solution
4.1	Air leak between the water box and pump.	Check all the hoses and fittings for cuts, breaks, cracks, etc. Repair as necessary.
4.2	The check valve(s) in the pump are faulty.	Remove each valve and inspect for correct operation. See the Machine Maintenance Section.
4.3	The chemical pump is not primed.	Prime the chemical pump.

5.0 Water box empty or fills slowly

	Possible Cause	Solution
5.1	Restriction in the water supply system.	Inspect the supply system from the source through the incoming quick connect.
5.2	The float valve in the water box is faulty.	Disassemble and inspect the valve. Repair or replace as necessary.

6.0 The water box overflows

	Possible Cause	Solution
6.1	The float valve in the water box is faulty.	Disassemble and inspect the valve. Repair or replace as necessary.
6.2	The float has absorbed water and lost buoyancy.	Detach the float and check to see if it will float to the surface. Replace the valve as necessary.
6.3	The float has come out of adjustment.	Adjust the float as necessary.

VACUUM SYSTEM

1.0 A weak vacuum at wand. The gauge reads normal.

	Possible Cause	Solution
1.1	Blockage in the hoses or wand tube	Disconnect the hoses and check for an obstruction.
1.2	Excessive length of hose connected to the truckmount	Do not attach excessive lengths of hose.

2.0 A weak vacuum

	Possible Cause	Solution
2.1	Air leak somewhere in the vacuum system.	Check the vacuum relief valve for proper adjustment.
		Carefully check all the vacuum hoses for a cut or break.
		Check the recovery tank lid gasket.
		Make sure the recovery tank drain valve is fully closed.
2.2	The vacuum blower is turning too slowly.	Check the rpm of the engine. Adjust as necessary to 3,150 rpm under a 0" Hg vacuum load.
2.3	The vacuum gauge is defective.	Test the gauge and replace if necessary.

3.0 The vacuum gauge reads too high with no hoses attached

	Possible Cause	Solution
3.1	The filter in recovery tank is clogged.	Remove and clean or replace as necessary.
3.2	The hose from recovery tank to the vacuum blower is collapsed internally.	Inspect and replace as necessary.

4.0 Excessive noise produced by the blower

	Possible Cause	Solution
4.1	The blower is low on oil.	Inspect the oil levels and replenish as necessary. Note: Running the blower with low oil levels can cause severe damage. If this situation occurs the blower should be inspected by a qualified service technician.
4.2	The vacuum blower has internal damage.	Refer to a qualified service technician.

5.0 The vacuum blower is locked and will not turn

	Possible Cause	Solution
5.1	Truckmount has been inactive for a period of time and the blower was not properly lubricated prior to final shutdown. Rust has possibly built up on the internal surfaces.	Spray penetrating oil into the blower and let sit for at least 1 hour. Then very carefully use pipe wrench on the outer diameter of the pulley on the coupler to attempt to free lobes of the blower. Do not use a wrench directly on the blower shaft.
		If unable to free up the blower in this manner, refer to a qualified service technician.
5.2	There is internal damage to the blower.	Refer to a qualified service technician.

6.0 Water in truckmount exhaust

	Possible Cause	Solution
6.1	The recovery tank has been filled with foam or overfilled with water.	Inspect the recovery tank. If full, drain the tank.
		Inspect the high level shutoff switch for proper operation. Clean or replace the switch as necessary.
		If foam is in recovery tank, use de-foamer on the carpet being cleaned.
6.2	Condensation in system.	This will be more common in cool weather and humid climates. If this is the cause, it should dissipate after a few minutes of running.
6.3	The heat exchanger is leaking water.	Inspect and repair or replace as necessary.

8 - Assemblies and Parts List

This section of the manual provides detailed illustrations and parts lists for the following assemblies.

NOTICE

When ordering parts for assemblies, first refer to the appropriate assembly listed here and then find the part number listed on that specific page. In most cases, you do not have to order the entire assembly to get a part.

If you have an electronic copy (a .pdf) of this manual, you can search for the part number by pressing the **CTRL** key and the **F** key at the same time. This will “pop up” the Find window on your monitor. Type the part number, including dashes, into the Find window and press the **Enter** key.

■ Console Assembly Parts List	8-8	■ Idler Pulley Assembly Parts List.....	8-30
■ Frame Assembly Parts List	8-11	■ Exhaust Assembly Parts List.....	8-31
■ Engine Assembly Parts List	8-14	■ 65 Gallon Universal Recovery Tank (URT) Assembly Parts List.....	8-34
■ Blower Assembly Parts List.....	8-16	■ 100 Gallon Universal Recovery Tank (URT) Assembly Parts List.....	8-36
■ Pump Assembly Parts List	8-18	■ 100 Gallon Universal Recovery Tank (URT) Cover Assembly Parts List	8-37
■ Heat Exchanger Assembly Parts List.....	8-20	■ Vacuum Relief Valve Assembly Parts List.....	8-38
■ Silencer Assembly Parts List.....	8-21	■ 70 Gallon Fresh Water Tank (FWT) Assembly Parts List.....	8-41
■ Water Box Assembly Parts List.....	8-23	■ Dura-Flow APO 90 Degree Assembly Parts List.....	8-43
■ Dash Assembly Parts List	8-26	■ APO Pump Assembly Parts List.....	8-44
■ Differential Check Valve Assembly Parts List.....	8-27	■ APO Connection Kit Assembly Parts List.....	8-45
■ By-Pass Valve Assembly Parts List.....	8-28	■ Hose Routings	8-46
■ Orifice Assembly Parts List	8-29		

Some of the illustrations in this section reference sealants, thread lockers, adhesive, primer, anti-seize and lubricant specifications that are used in the construction of HydraMaster equipment.

Refer to Figure 8-1 to identify those substances such as A1, A2 and so forth. Equivalent products are acceptable if they meet or exceed current specifications and are approved by HydraMaster.



Figure 8-1. Adhesive/Sealant Material Reference

Figure 8-2. Console Assembly - View 1 of 5
610-050-737 Rev. A

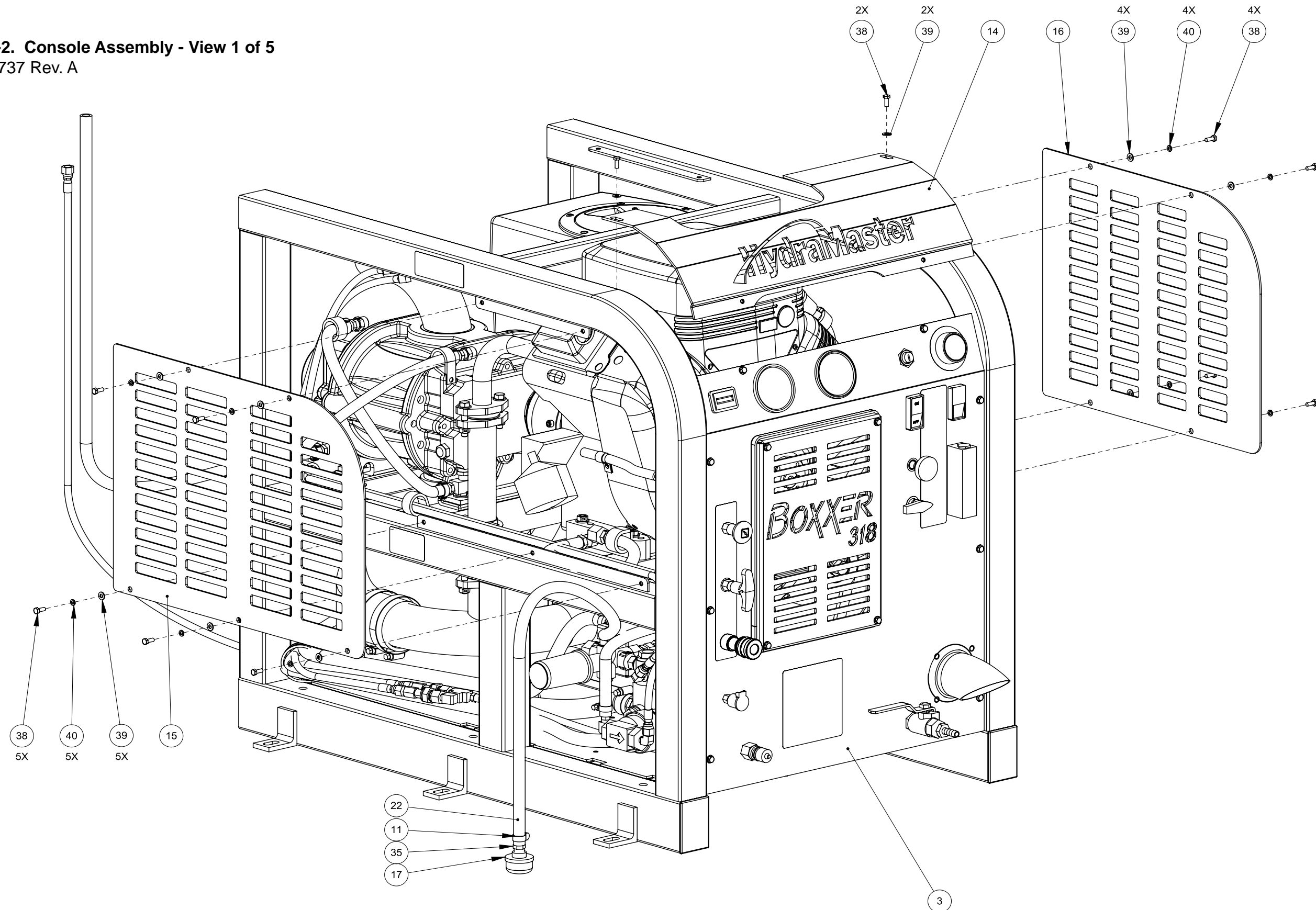

Figure 8-3. Console Assembly - View 2 of 5
610-050-737 Rev. A

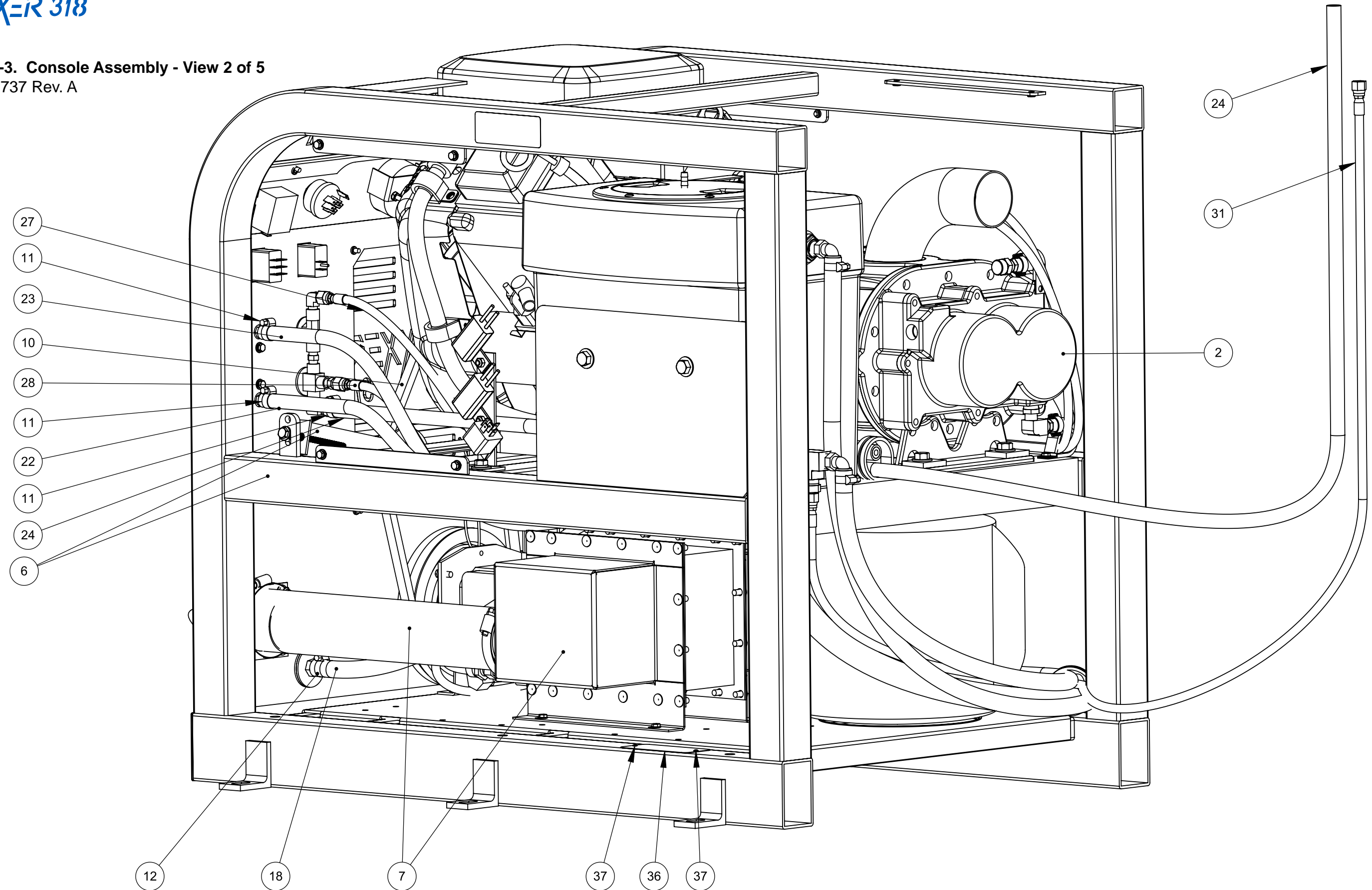

Figure 8-4. Console Assembly - View 3 of 5
610-050-737 Rev. A

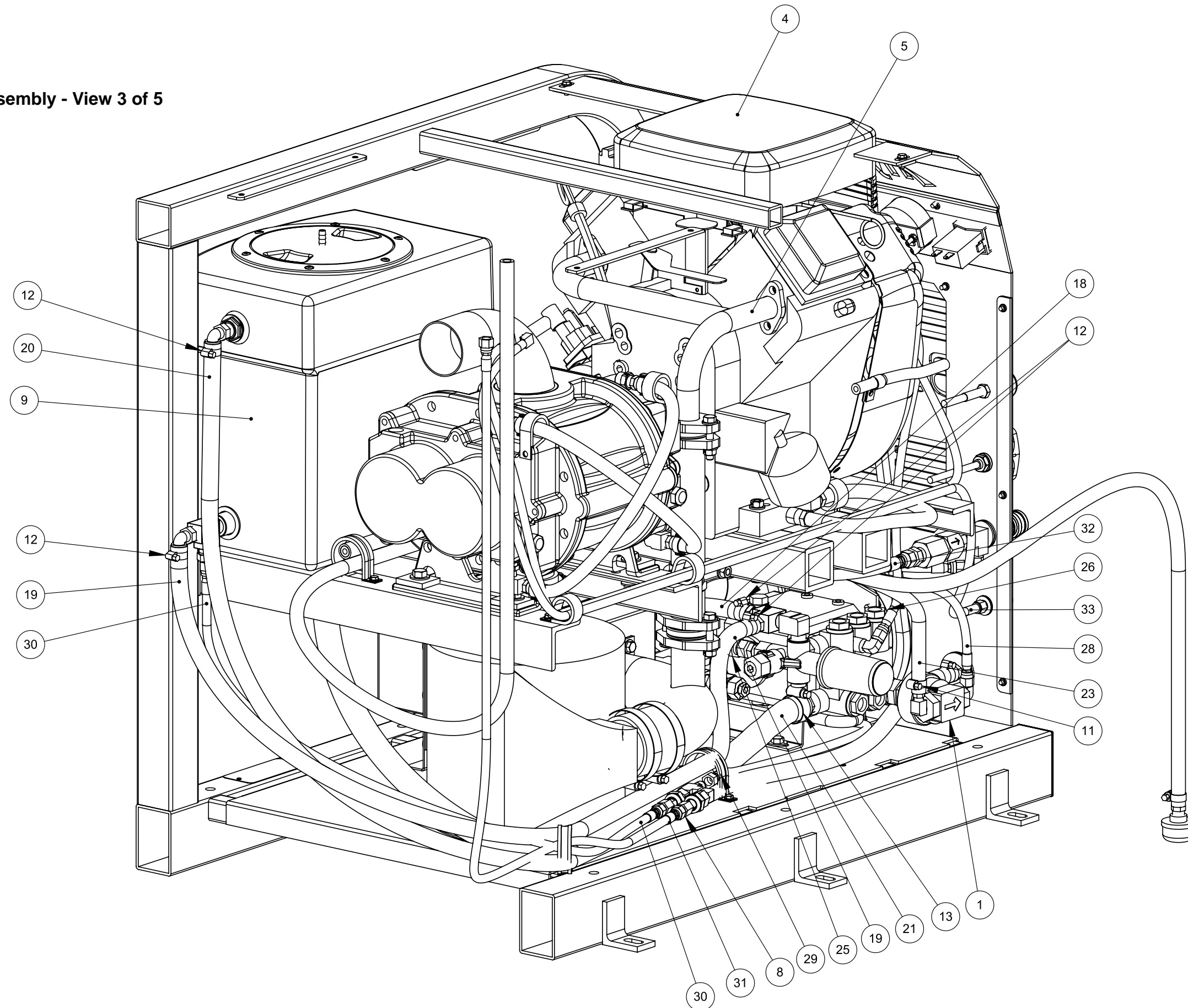

Figure 8-5. Console Assembly - View 4 of 5
610-050-737 Rev. A

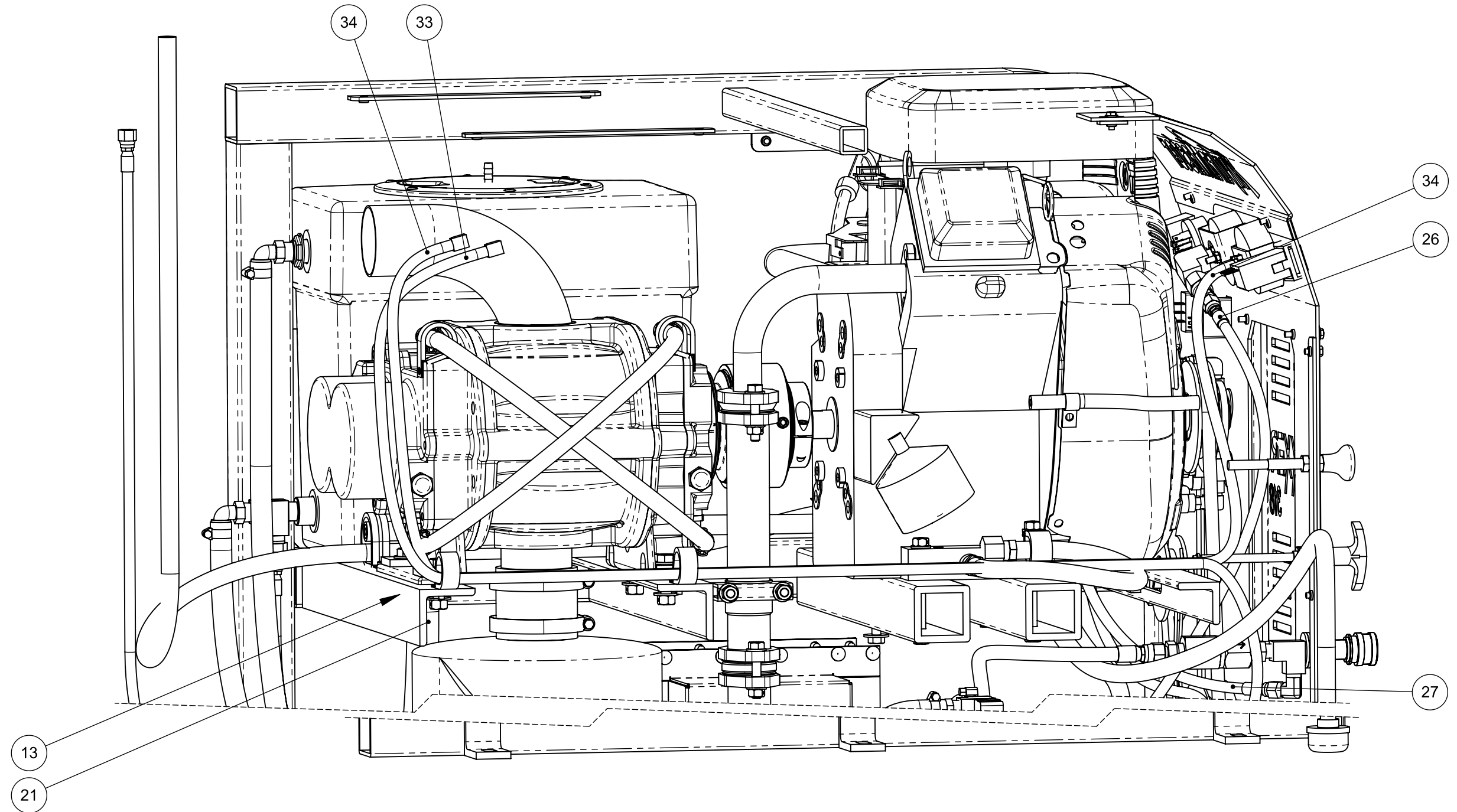
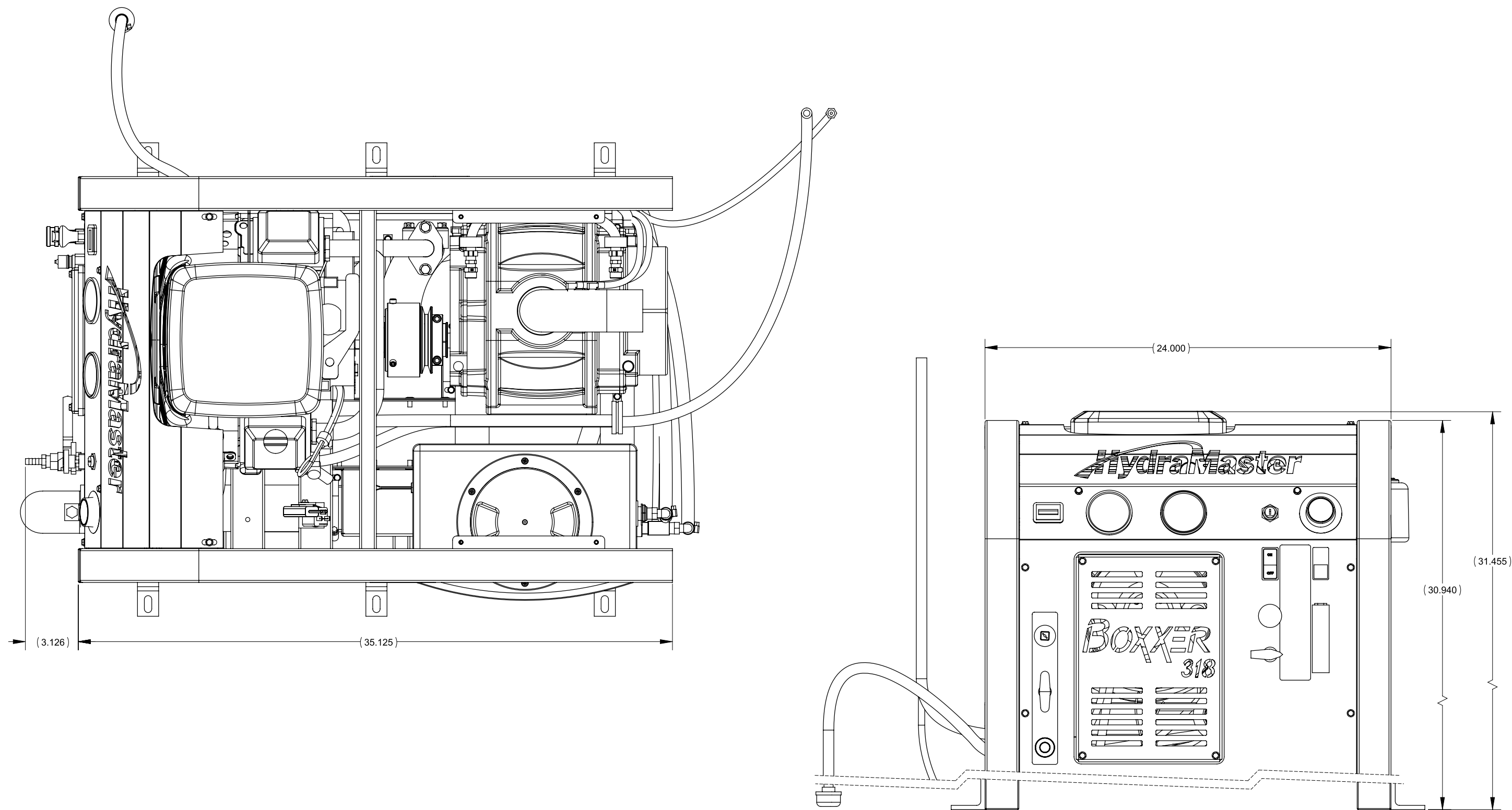

Figure 8-6. Console Assembly - View 5 of 5
610-050-737 Rev. A



Console Assembly Parts List

Item	Part Number	Description	Qty	Item	Part Number	Description	Qty
1	610-007-737	Assembly, Pump	1	24	000-068-972	Hose, 3/8" I.D. Rubber X 76" Lg. (Chemical Prime to Rec Tank)	1
2	610-002-725	Assembly, Blower	1	25	000-068-587	Hose, 3/8" I.D. Throb X 17.5" Lg. (Throb)	1
3	610-018-737	Assembly, Dash	1	26	000-068-518	Hose, 3/16" I.D. X 18.25" Lg. (Pump to Gauge)	1
4	610-004-724	Assembly, Engine	1	27	000-068-517	Hose, 3/16" I.D. X 23" Lg. (Chemical Metering to Solution Out)	1
5	610-013-729	Assembly, Exhaust	1	28	000-068-517	Hose, 3/16" I.D. X 23" Lg. (Chemical Pump to Prime)	1
6	610-001-729	Assembly, Frame	1	29	000-068-888	Hose, 3/16" I.D. X 24" Lg. (Heat Exchanger to Orifice Assy)	1
7	610-005-729	Assembly, Heat Exchanger	1	30	000-068-203	Hose, 3/16" I.D. X 34" Lg. (Orifice Assembly to Water Box)	1
8	610-021-729	Assembly, Orifice	1	31	000-068-627	Hose, 3/16" I.D. X 44" Lg. (Orifice Assembly to Rec Tank)	1
9	610-010-729	Assembly, Water Box	1	32	000-068-724	Hose, 5/16" I.D. X 18" Lg. (Heat Exchanger to Solution Out)	1
10	000-010-124	Belt, 9430HD	1	33	000-068-978	Hose, 5/32" I.D. Vacuum X 52" Lg. (Blower to Lube Port)	1
11	000-033-003	Clamp, Size #4 Mini Hose	5	34	000-068-977	Hose, 5/32" I.D. Vacuum X 82" Lg. (Blower to Vacuum Gauge)	1
12	000-033-005	Clamp, Size #5 Hose	6	35	000-052-102	Insert, #46 (1/4" NPT X 3/8" Barb)	1
13	000-033-029	Clamp, Size #12 Hose	2	36	000-105-012	Plate, Machine Serial I.D.	1
14	000-041-011	Cover, Brow - Machine - Coated	1	37	000-140-001	Rivet, AB4-3A Aluminum Pop 1/8" X 1/4" Lg.	2
15	000-041-451	Cover, Left Side - Coated	1	38	000-143-126	Screw, #10-24UNC X 0.50" Lg. Hex Head	11
16	000-041-452	Cover, Right Side - Coated	1	39	000-174-001	Washer, #10 Flat	11
17	000-049-118	Filter, Chemical Inlet High Pressure	1	40	000-174-014	Washer, #10 Lock	9
18	000-068-967	Hose, 1/2" I.D. Rubber X 20" Lg. (Water Box Drain)	1				
19	000-068-968	Hose, 1/2" I.D. Rubber X 56" Lg. (Pump to Water Box)	1				
20	000-068-969	Hose, 1/2" I.D. Rubber X 69" Lg. (Fresh Water In to Water Box)	1				
21	000-068-970	Hose, 3/4" I.D. Rubber X 50" Lg. (Pump to Water Box)	1				
22	000-068-980	Hose, 3/8" I.D. Clear w/ Braid X 28.5" Lg. (Chemical Jug to Flow)	1				
23	000-068-971	Hose, 3/8" I.D. Clear w/ Braid X 60" Lg. (Chemical Pump to Flow)	1				

Figure 8-7. Frame Assembly - View 1 of 2
610-001-729 Rev. E

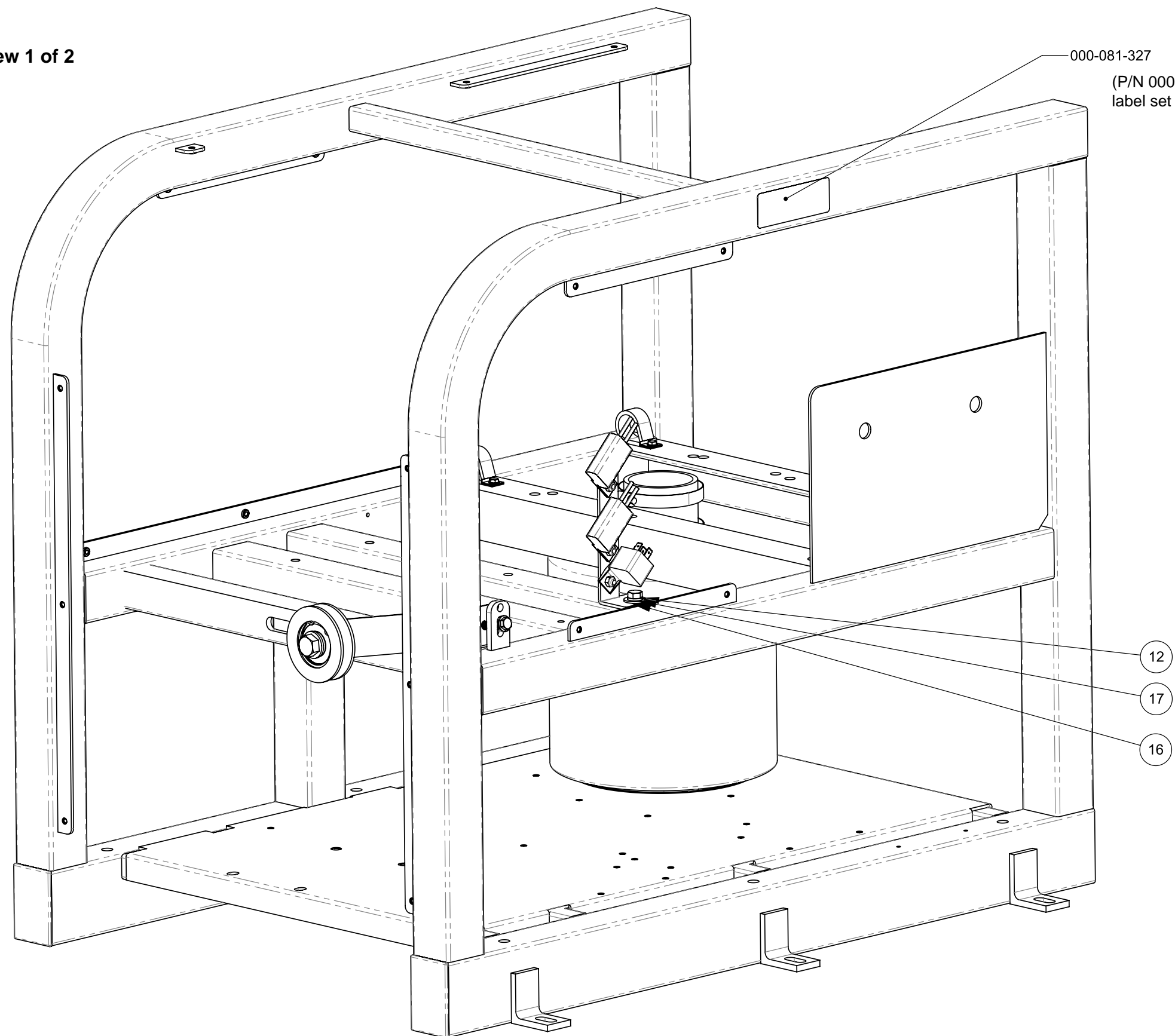

000-081-327

(P/N 000-081-327 available only as part of label set P/N 000-081-039.)

12

17

16

Figure 8-8. Frame Assembly -View 2 of 2
610-001-729 Rev. E

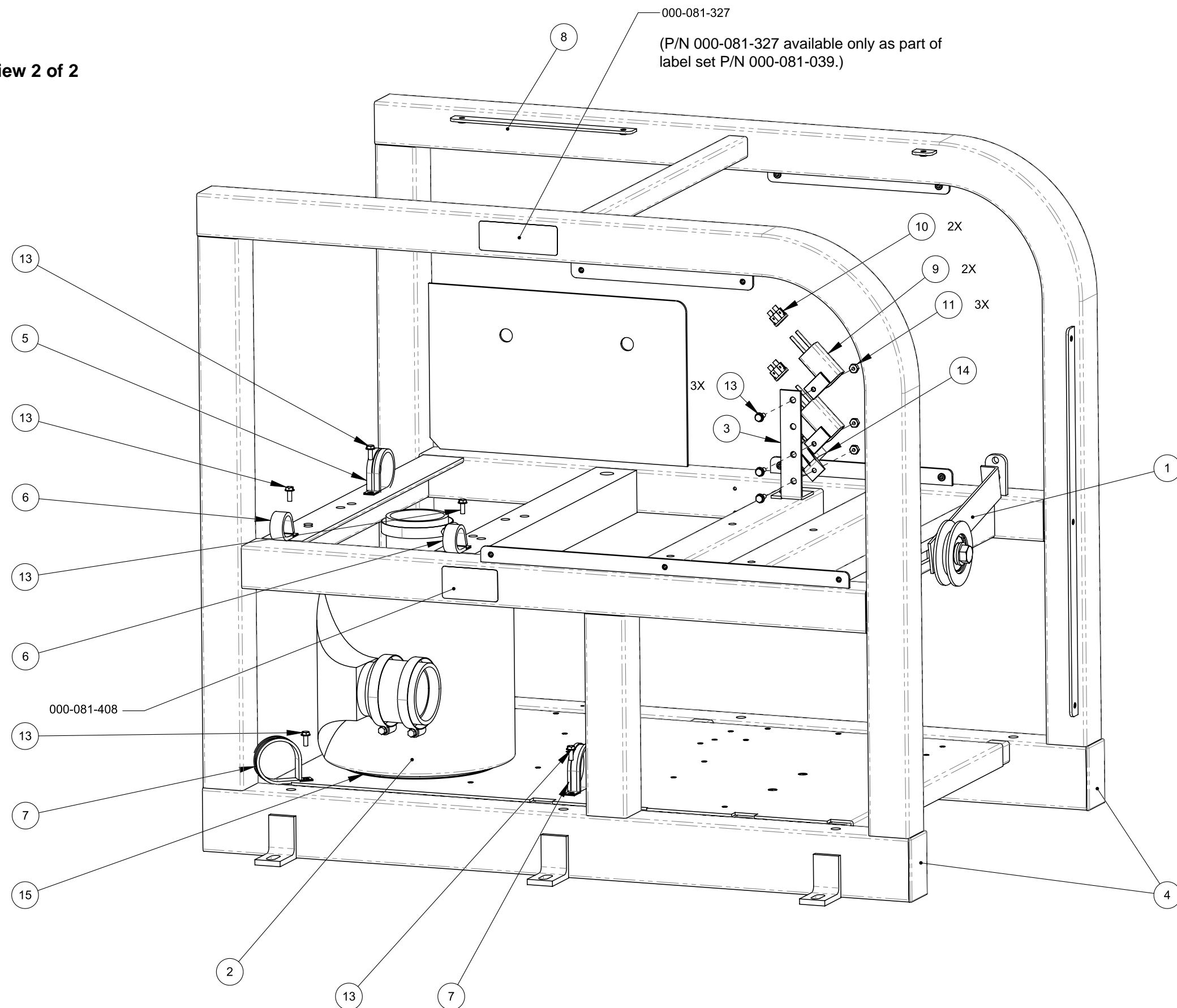

Frame Assembly Parts List

Item	Part Number	Description	Qty
1	610-021-009	Assembly, Idler Pulley	1
2	610-021-724	Assembly, Silencer	1
3	000-015-177	Bracket, Dual Heat Exchanger Mounting - Left - Coated	1
4	000-027-110	Cap, 2" X 3" Frame End	2
5	000-033-050	Clamp, 1-3/4" Cushion Loop	1
6	000-033-057	Clamp, 1" Cushion Loop	2
7	000-033-067	Clamp, 2" Cushion Loop	2
8	000-055-195	Frame, Complete - Coated	1
9	000-056-006	Fuse Holder, In-Line - Weatherproof	2
10	000-056-011	Fuse, 30 Amp	2
11	000-094-034	Nut, #10-24UNC Nylock	3

Item	Part Number	Description	Qty
12	000-143-012	Screw, 5/16"-18UNC X 3/4" Lg.	1
13	000-143-583	Screw, #10-24UNC X 0.50" Lg. Hex Head Flange Z/P	8
14	000-157-022	Switch, Relay	1
15	000-131-131	Trimlok, 3/8" X 1/8" Rubber - Bulk	1
16	000-174-004	Washer, 5/16" Flat, USS	1
17	000-174-018	Washer, 5/16" Lock	1

Figure 8-9. Engine Assembly - Part 1 of 2
610-004-724 Rev. G

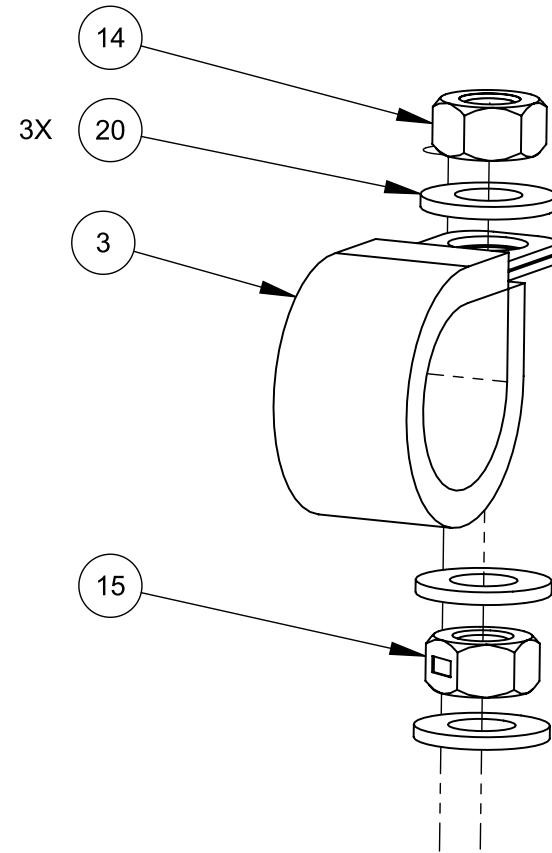

DETAIL VIEW A

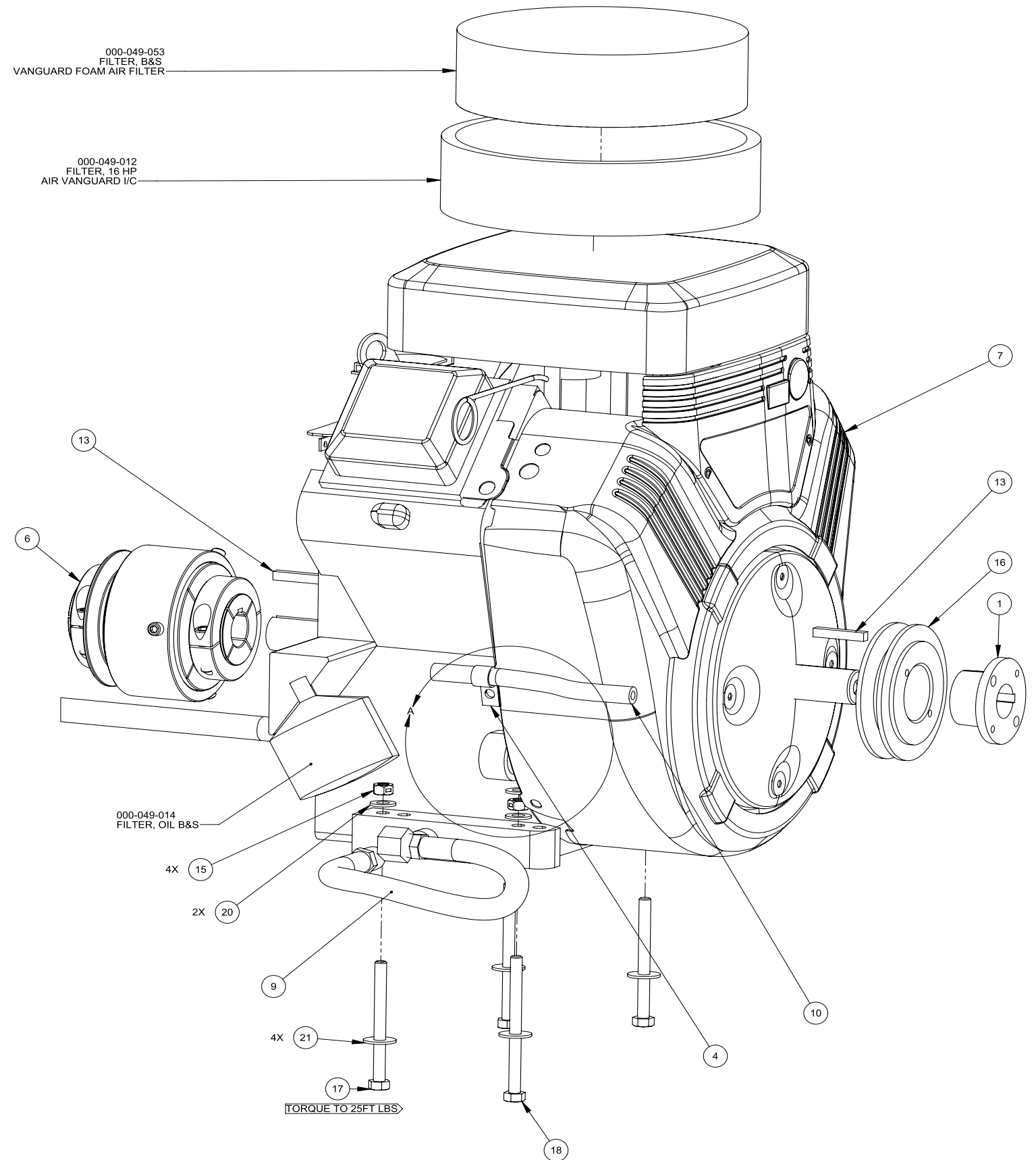
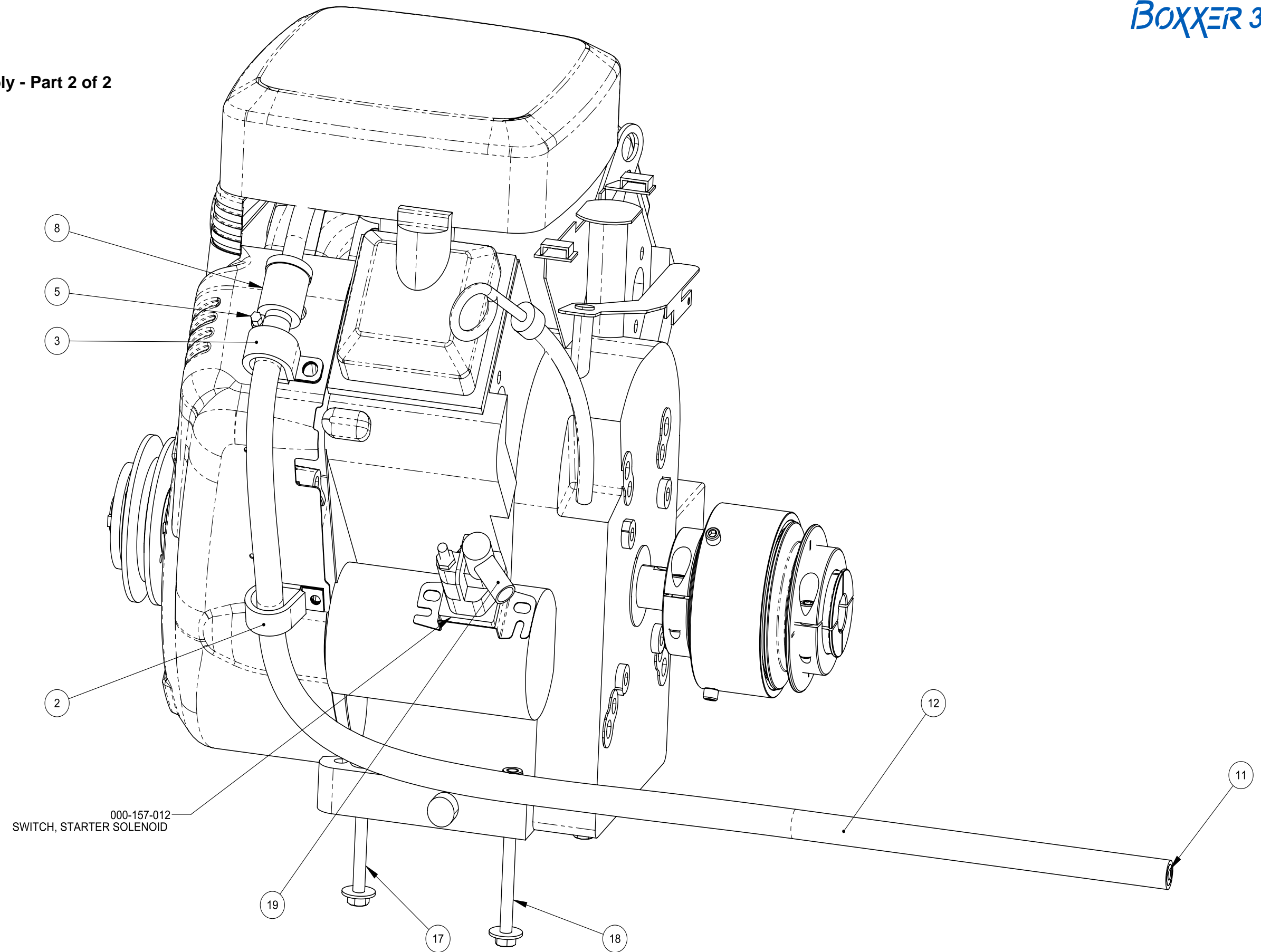

Figure 8-10. Engine Assembly - Part 2 of 2
610-004-724 Rev. G



Engine Assembly Parts List

Item	Part Number	Description	Qty	Item	Part Number	Description	Qty
1	000-020-025	Bushing, H X 1"	1	12	000-131-139	Insulation, 1" Hi-Temp Alum Sleeve X 60" Lg.	1
2	000-033-057	Clamp, 1" Cushion Loop	1	13	000-077-010	Key, 1/4" X 1-1/2" Lg. Class 2 Fit	2
3	000-033-117	Clamp, 1" Cushion Loop w/ 7/16 Mount Hole	2	14	000-094-012	Nut, 5/16"-18UNC Hex	1
4	000-033-046	Clamp, 1/2" Wide X 1/2" Tube	1	15	000-094-081	Nut, 5/16"-18UNC Hex 2 Way Locking	4
5	000-033-003	Clamp, Size #4 Mini Hose	1	16	000-109-040	Pulley, AK47-H	1
6	000-039-054	Coupler, 40 Series	1	17	000-143-659	Screw, 5/16"-18UNC X 3.5" Lg. Grade 8	2
7	000-047-028	Engine, 18Hp	1	18	000-143-660	Screw, 5/16"-18UNC X 4.0" Lg., Hex Head	2
8	000-049-258	Filter, Fuel	1	19	000-152-009	Sleeve, Solenoid Insulator	1
9	000-068-219	Hose Assembly, Pump Drain	1	20	000-174-049	Washer, 5/16" Flat	6
10	000-068-157	Hose, 1/4" Fuel, Low Perm, Non Fuel Injected Only	1	21	000-174-004	Washer, 5/16" Flat, USS	4
11	000-068-979	Hose, 1/4" I.D. Fuel Low Perm X 120" Lg.	1				

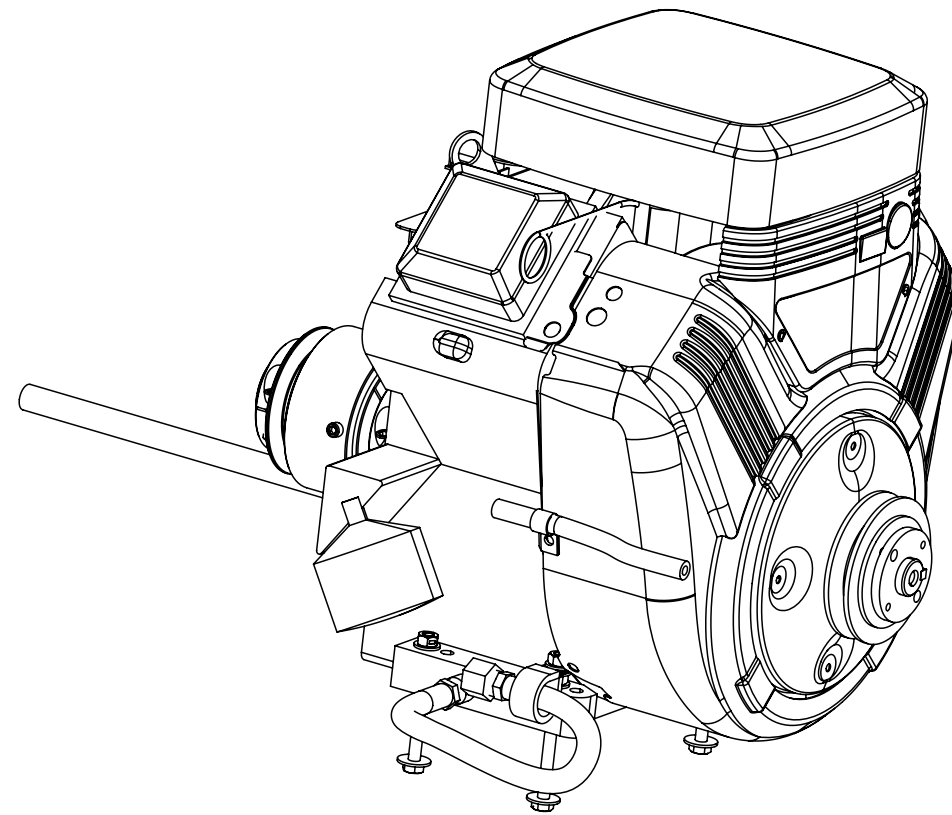

Figure 8-11. Blower Assembly - View 1 of 2
610-002-725 Rev. G

NOTICE

See Figure 8-1 for adhesive/sealant information.

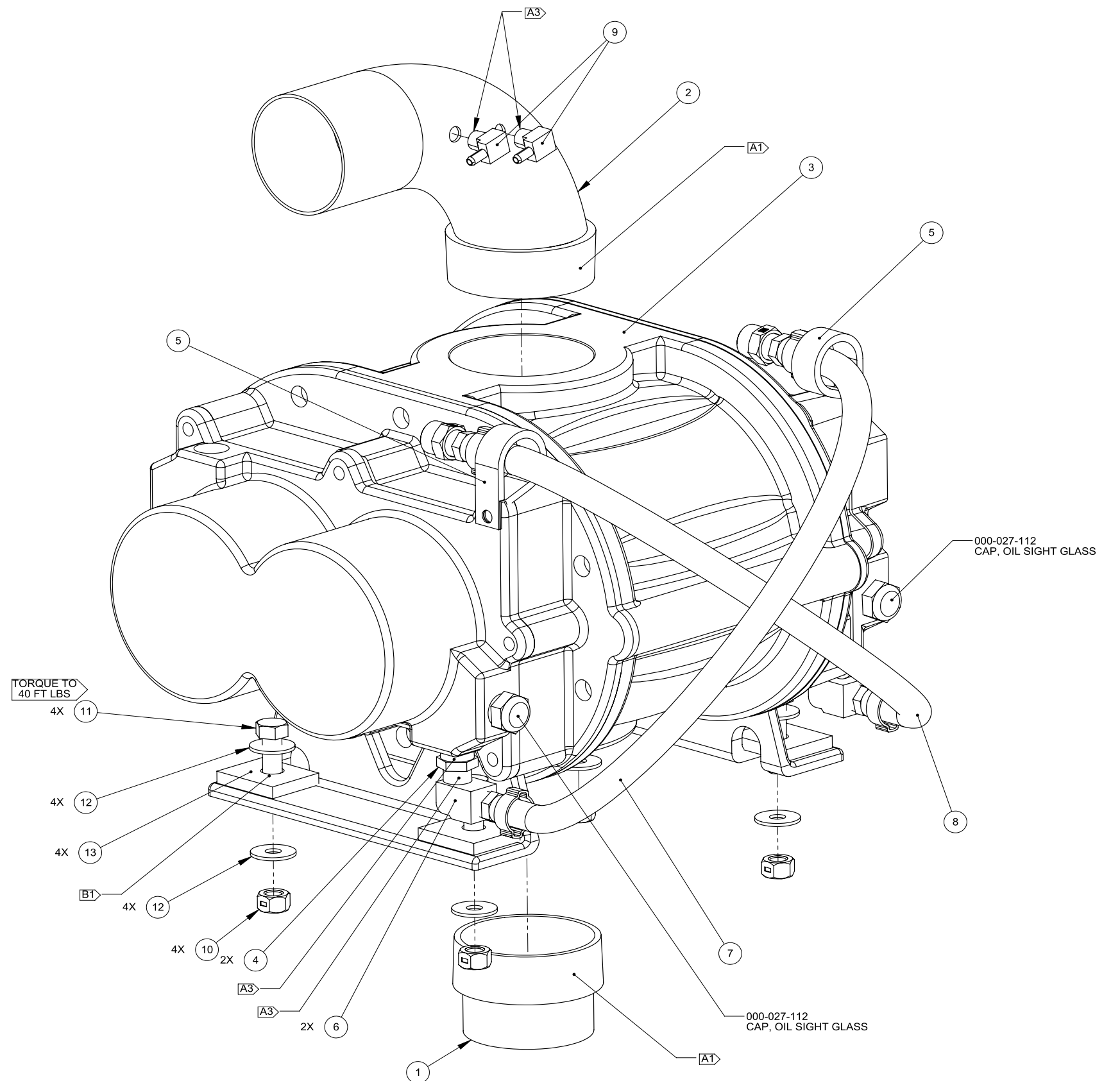
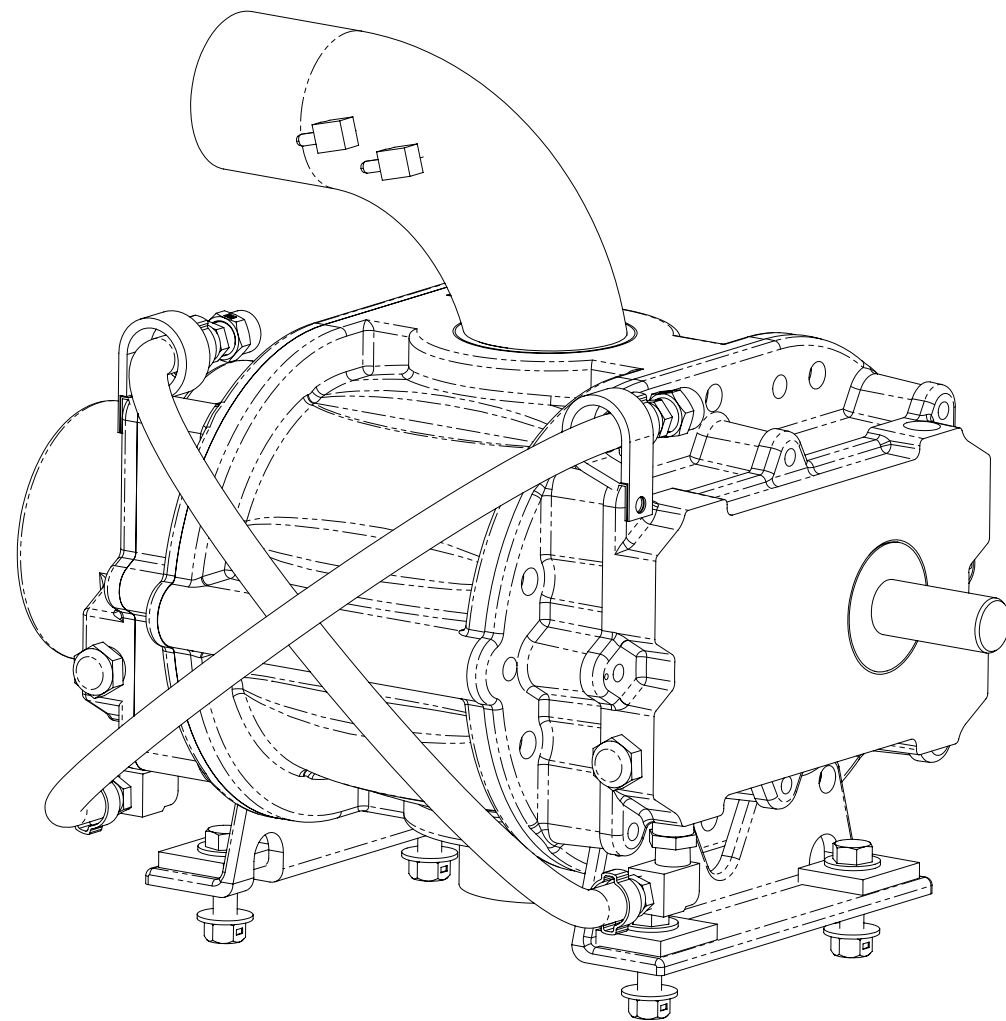
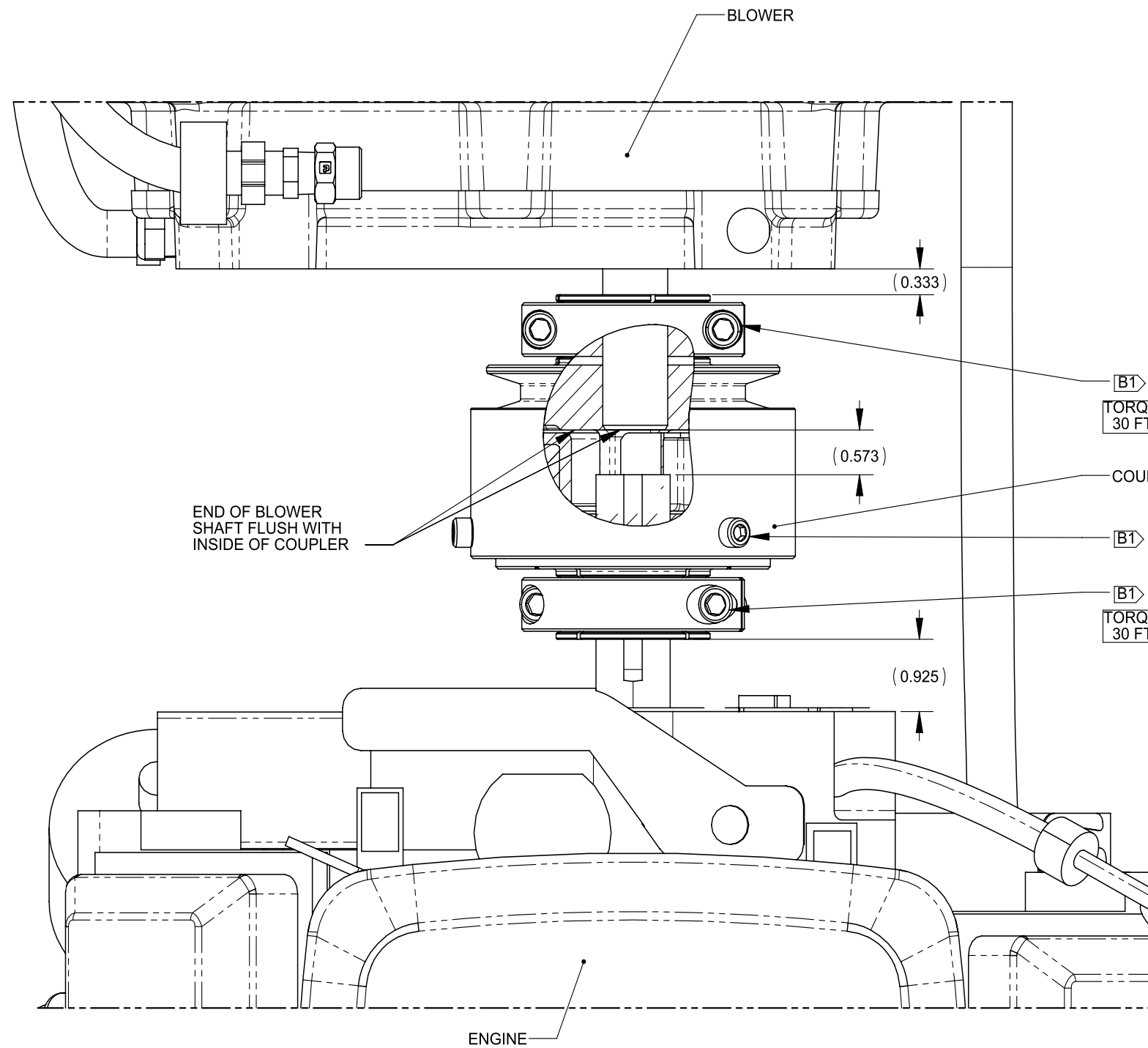

Figure 8-12. Blower Assembly - View 2 of 2
610-002-725 Rev. G



Blower Assembly Parts List

Item	Part Number	Description	Qty
1	000-001-140	Adapter, 2 1/2" NPT to 2 1/2" O.D.Tube - Coated	1
2	000-001-141	Adapter, 2.5" MNPT X 2.5" O.D.Elbow - Coated	1
3	000-111-134	Blower, 3006 Competitor	1
4	000-052-061	Bushing, 3/8" NPT X 1/4" FPT	2
5	000-033-057	Clamp, 1" Cushion Loop	2
6	000-052-085	Elbow, 1/4" NPT Street	2
7	000-068-794	Hose Assembly, 3/8" I.D. Hi Temp Rubber X 17" Lg. Drain	1
8	000-068-794	Hose Assembly, 3/8" I.D. Hi Temp Rubber X 17" Lg. Drain	1
9	000-052-106	Insert, 1/8" NPT X 5/32" Barb X 90 Degree	2
10	000-094-015	Nut, 3/8"-16UNC Hex 2-Way Locking	4
11	000-143-200	Screw, 3/8"-16UNC X 1.5" Lg. Hex Head Grade 8	4
12	000-174-004	Washer, 5/16" Flat, USS	8
13	000-174-068	Washer, Blower Feet - Coated	4

NOTICE

See Figure 8-1 for adhesive/sealant information.

Figure 8-13. Pump Assembly - View 1 of 2
610-007-737 Rev. A

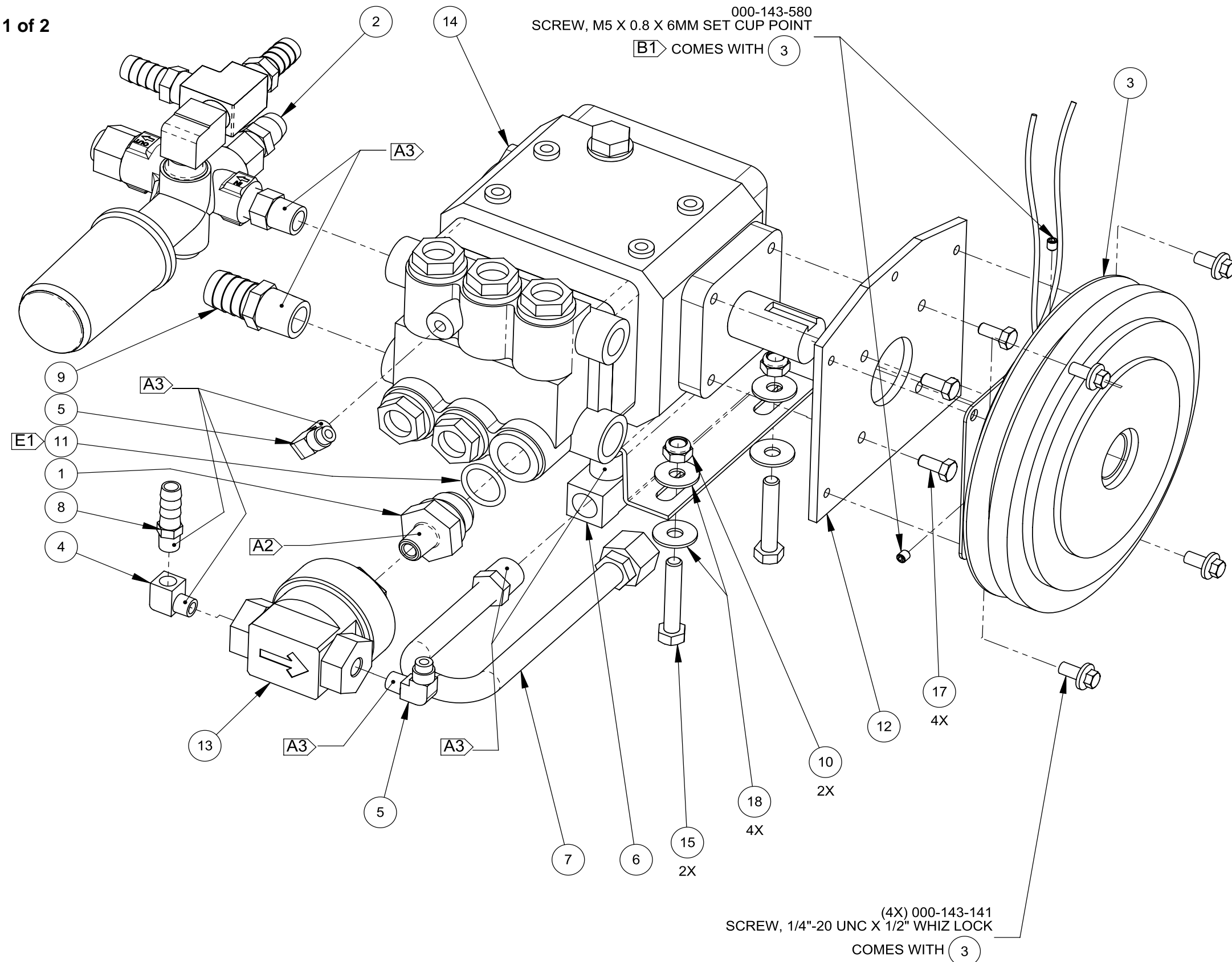
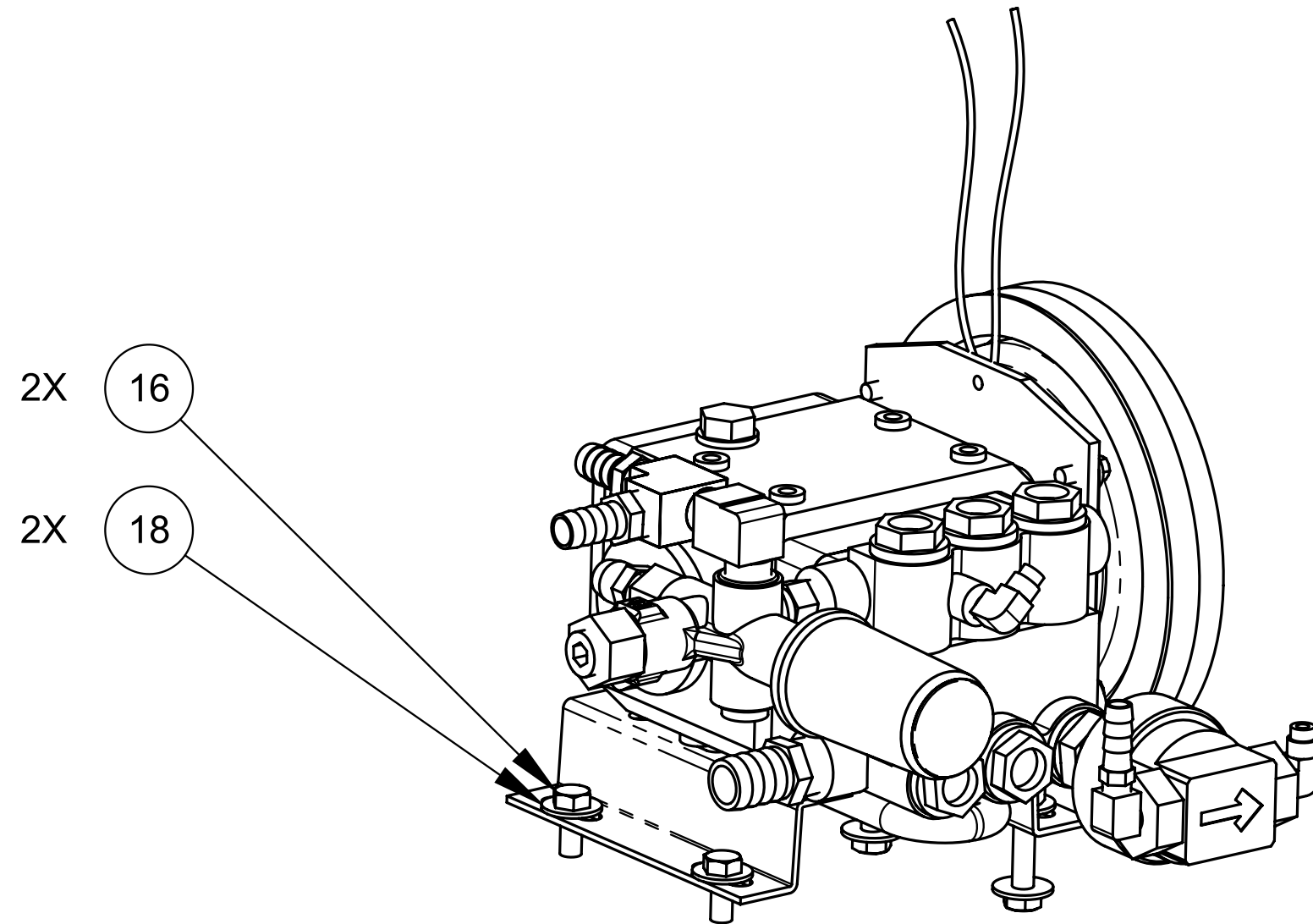

Figure 8-14. Pump Assembly - View 2 of 2
610-007-737 Rev. A



Pump Assembly Parts List

Item	Part Number	Description	Qty
1	000-001-096	Adapter, Chemical Pump	1
2	610-009-729	Assembly, By-Pass Valve	1
3	000-036-008	Clutch, 7" O.D. 24mm Single Groove	1
4	000-052-084	Elbow, 1/8" NPT Street	1
5	000-052-531	Elbow, 1/8" NPT X 1/4" SAE	2
6	000-052-086	Elbow, 3/8" NPT Street	1
7	000-068-219	Hose, Drain	1
8	000-052-099	Insert, #26 (1/8" NPT X 3/8" Barb)	1
9	000-052-129	Insert, #812, 1/2NPT X 3/4 Hose	1
10	000-094-038	Nut, 5/16"-18UNC Hex Nylock	2
11	000-097-057	O-Ring, Adapter - Chemical Pump	1
12	000-105-148	Plate, Clutch Mount Comet Pump	1
13	000-111-184	Pump, GP Chemical	1
14	000-111-042	Pump	1
15	000-143-375	Screw, 5/16"-18UNC X 1.75" Lg. Hex Head Grd. 8 Z/P	2
16	000-143-012	Screw, 5/16"-18UNC X 3/4" Lg.	2
17	000-143-221	Screw, M6-1 X 14mm Lg. Hex Head	4
18	000-174-004	Washer, 5/16" Flat, USS	6

Figure 8-15. Heat Exchanger Assembly
610-005-729 Rev. C

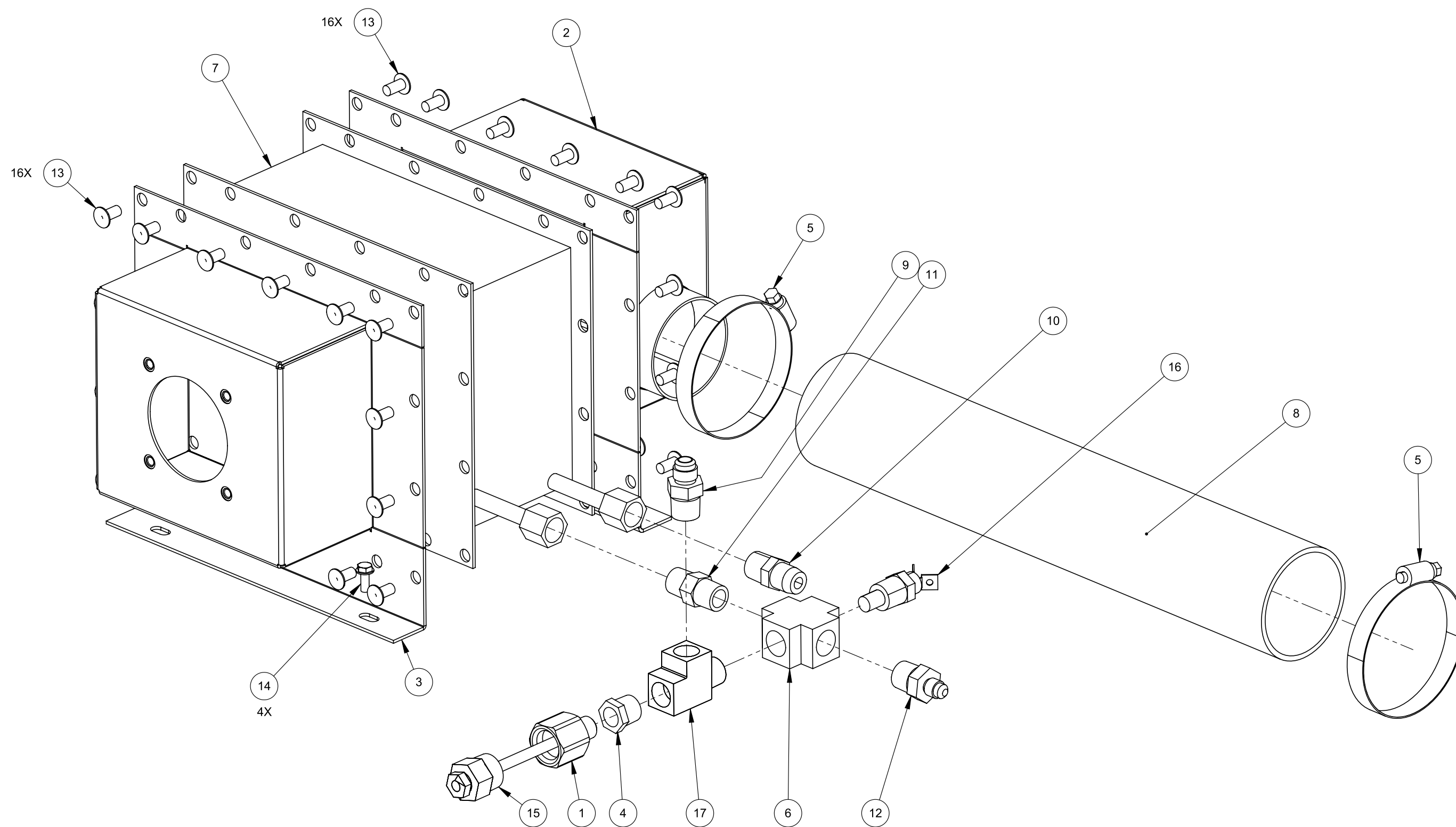

Heat Exchanger Assembly Parts List

Item	Part Number	Description	Qty
1	000-052-738	Adapter, 1/4" NPT X 1/2" FPT	1
2	000-013-115	Box, Outlet Plenum, Steel - Coated	1
3	000-013-118	Box, Plenum Inlet, Steel - Coated	1
4	000-052-061	Bushing, 3/8" NPT X 1/4" FPT	1
5	000-033-012	Clamp, Size #44 Hose	2
6	000-052-113	Cross, 3/8" FPT	1
7	000-038-072	Heat Exchanger, 4 Row	1
8	000-068-986	Hose, 2.5" Heat Flex Ns X 15" Lg.	1
9	000-052-528	Nipple, 3/8" M Jic X 3/8" NPT	1

Item	Part Number	Description	Qty
10	000-052-128	Nipple, 3/8" Mpt X 3/8" SAE Flare	1
11	000-052-074	Nipple, 3/8" NPT Hex	1
12	000-052-662	Nipple, 3/8" NPT X 1/4" M SAE	1
13	000-140-021	Rivet, 1/4" Blind X 0.50" Lg.	32
14	000-143-583	Screw, #10-24UNC X 0.50" Lg. Hex Head Flange Z/P	4
15	- - -	Sensor (Comes with 000-149-025)	1
16	000-149-027	Sensor, 285F Nason- 3/8" NPT	1
17	000-052-023	Tee, 3/8" NPT Male Street	1

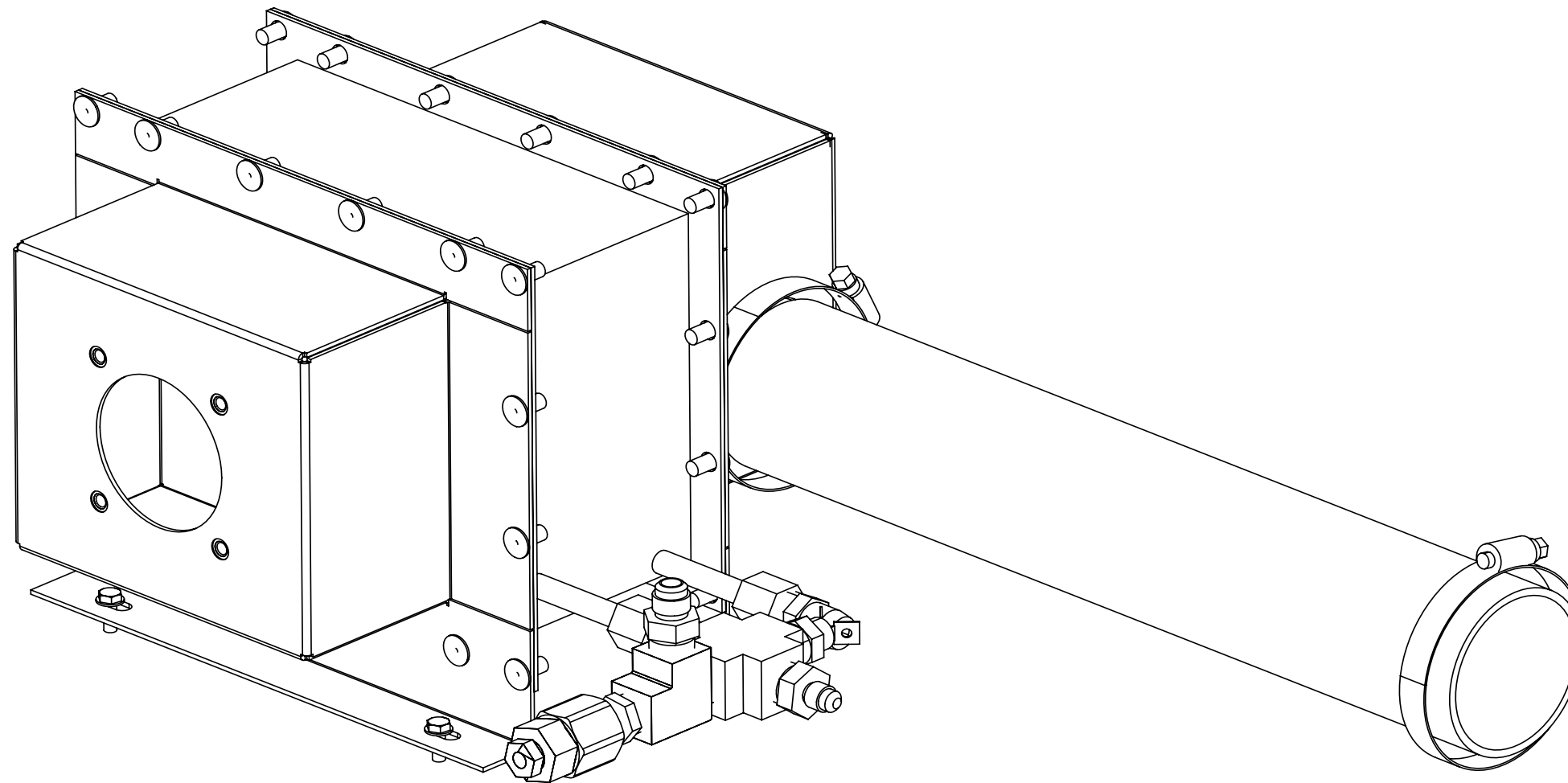

Figure 8-16. Silencer Assembly
610-021-724 Rev. B

Silencer Assembly Parts List

Item	Part Number	Description	Qty
1	000-033-012	Clamp, Size #44 Hose	4
2	000-068-104	Hose, Ø2.5" I.D. X 2.5" Lg.	2
3	000-093-108	Silencer, Ø2.5" O.D. Inlet/Outlet - Coated	1

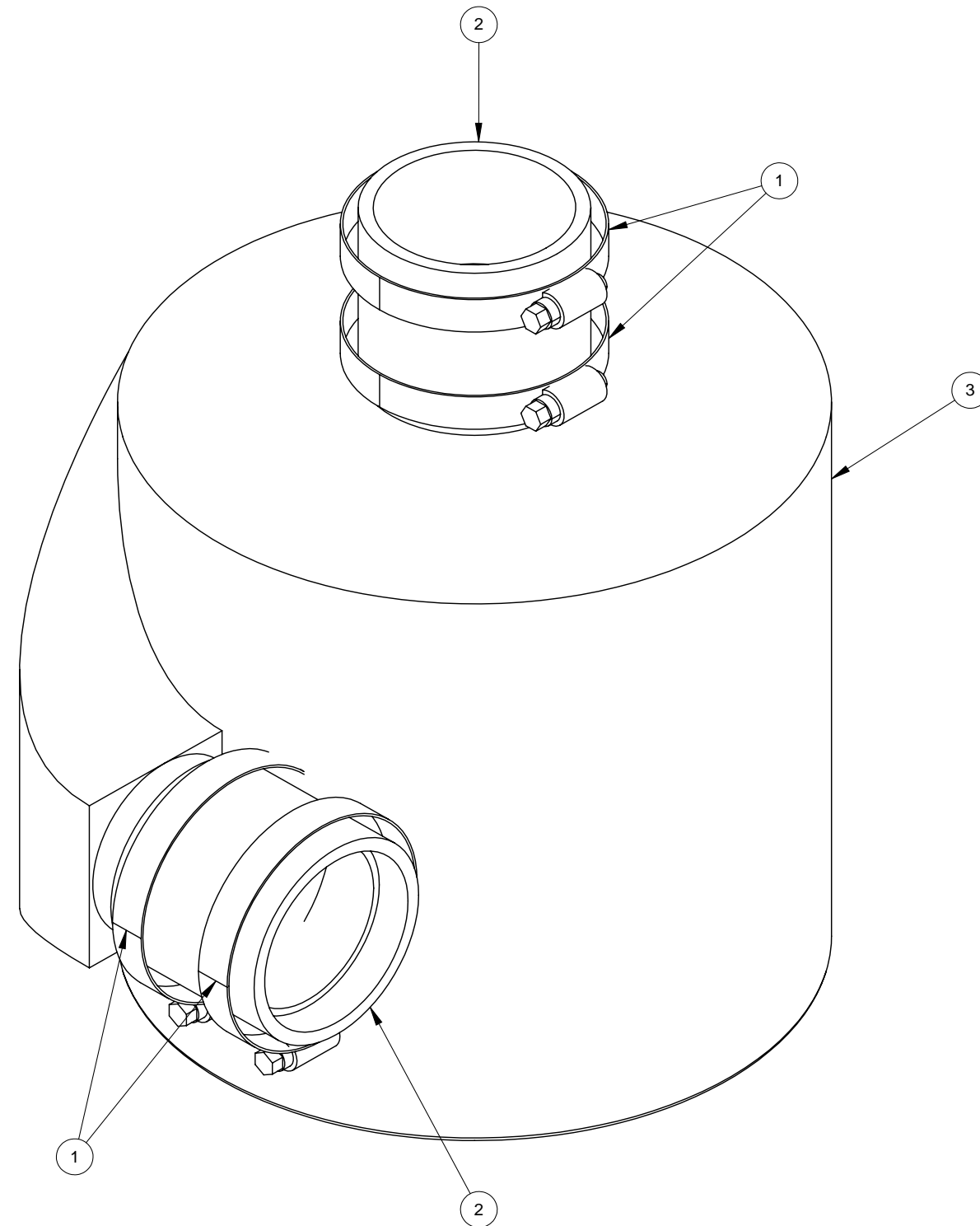
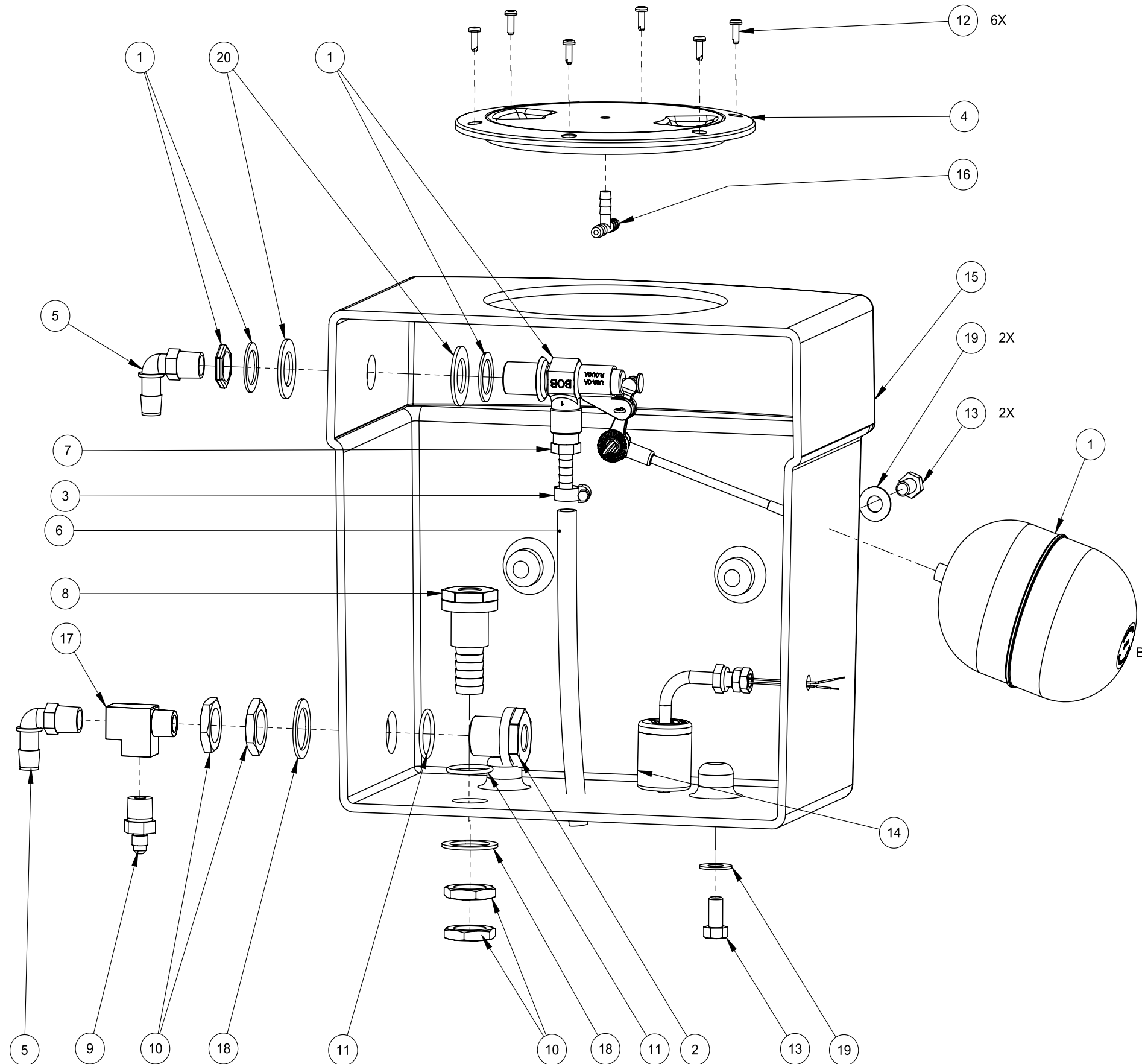

Figure 8-17. Water Box Assembly
610-010-729 Rev. B



Water Box Assembly Parts List

Item	Part Number	Description	Qty
1	000-169-235	Assembly, Robert Float Valve	1
2	000-052-660	Bulkhead, 3/8" FPT X 3/8" FPT	1
3	000-033-003	Clamp, Size #4 Mini Hose	1
4	000-041-005	Cover, 6" Access	1
5	000-052-355	Elbow, 3/8" NPT X 1/2" Hose, GFBN	2
6	000-068-827	Hose, 3/8" Clear w/ Braid X 8" Lg.	1
7	000-052-104	Insert, #66 (3/8" NPT X 3/8" Barb)	1
8	000-052-661	Insert, 3/4" Barb X Straight	1
9	000-052-662	Nipple, 3/8" NPT X 1/4" M SAE	1
10	000-094-097	Nut, 1"-14UNS Brass	4

Item	Part Number	Description	Qty
11	000-097-041	O-Ring, 1/2" Bulk Head	2
12	000-143-314	Screw, #8 X 1/2" Lg. Pan Head	6
13	000-143-017-1	Screw, 3/8"-16UNC X 3/4" Lg. Hex Head	3
14	000-157-0801	Switch, w/Protector, Polypropylene Barrel	1
15	000-159-190	Tank, Poly Water Box - 4 Gallon - Modified	1
16	000-052-156	Tee, 1/4" Plastic	1
17	000-052-023	Tee, 3/8" NPT Male Street	1
18	000-174-063	Washer, 1.5" O.D. X 1.073" I.D. X 0.075" Thk.	2
19	000-174-032	Washer, 3/8" Flat	3
20	000-174-028	Washer, 7/8" I.D. X 1.50" O.D. X 0.090" Thk.	2

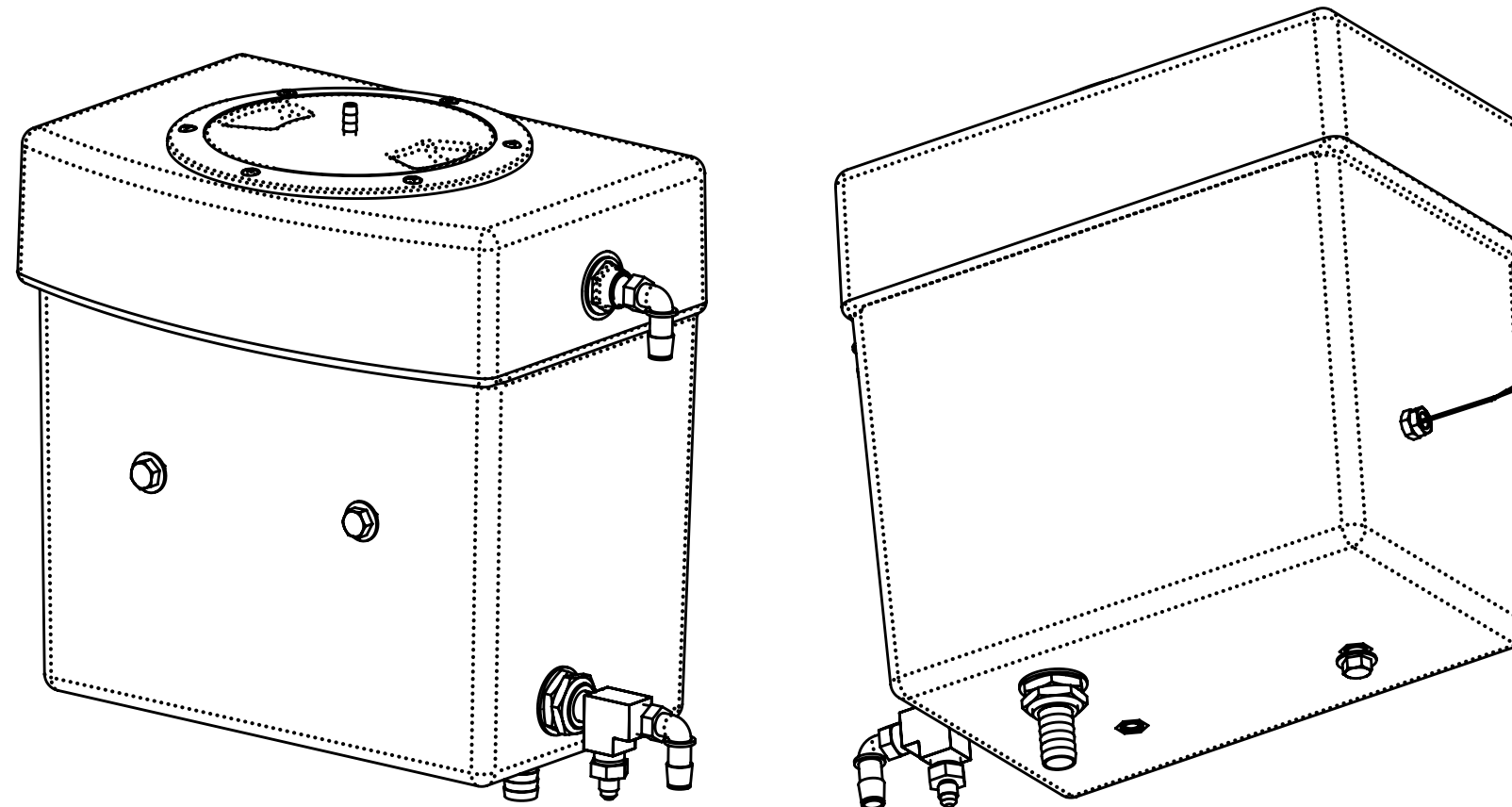

Figure 8-18. Dash Assembly - View 1 of 2
610-018-737 Rev. A

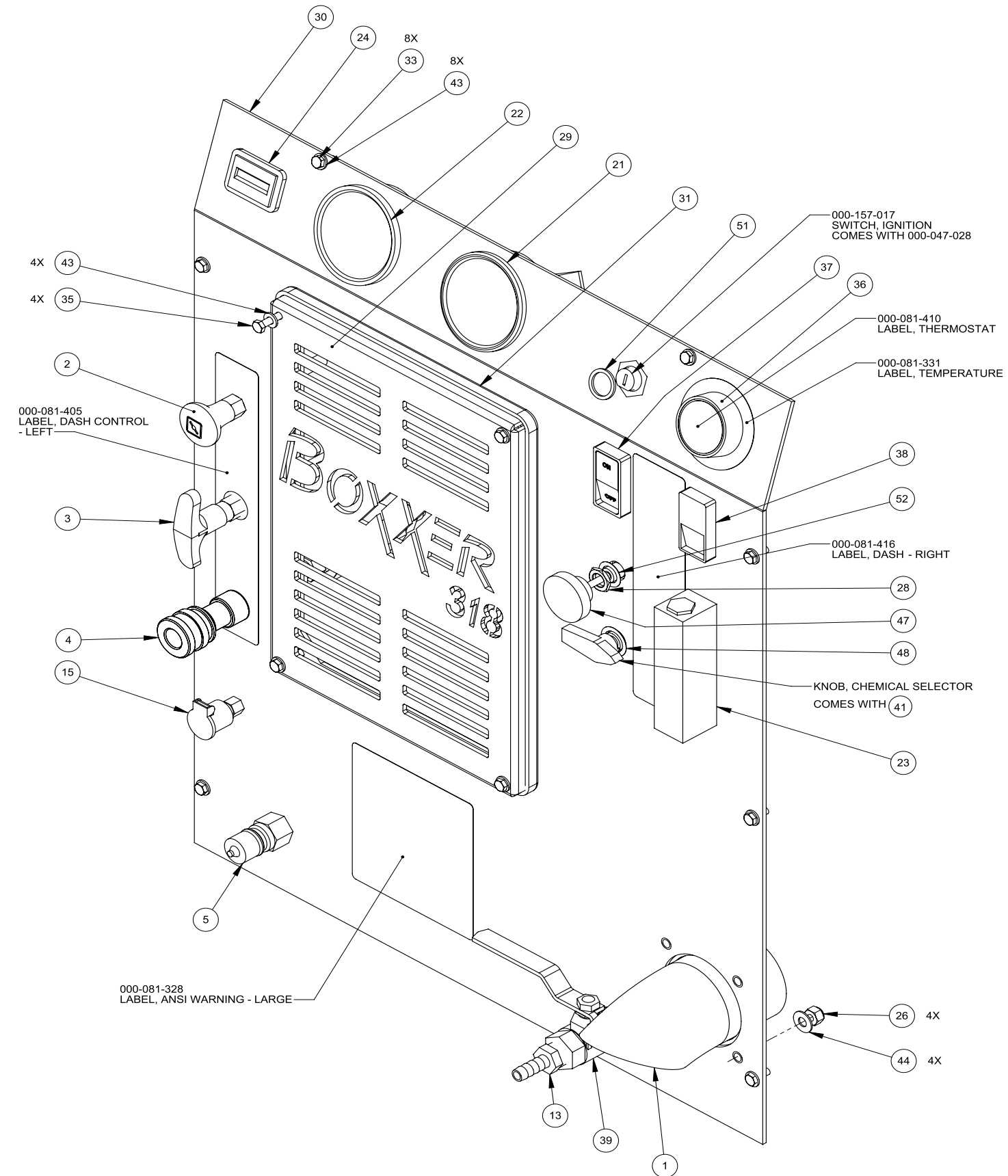
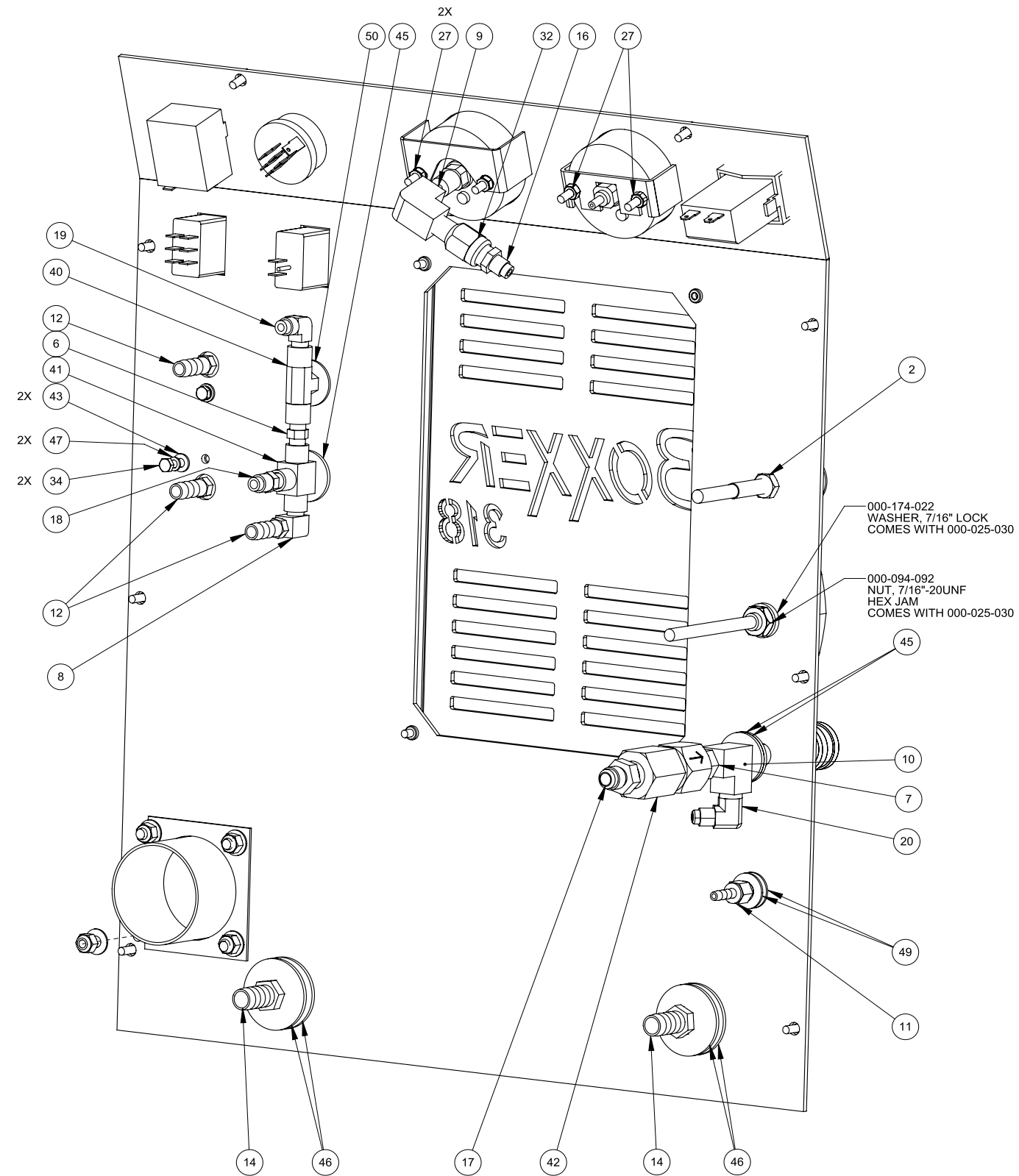

Figure 8-19. Dash Assembly - View 2 of 2
610-018-737 Rev. A



Dash Assembly Parts List

Item	Part Number	Description	Qty	Item	Part Number	Description	Qty
1	000-001-148	Adapter, 2.5" Exhaust Turndown - Coated	1	27	000-094-070	Nut, 5mm Hex Nylock	4
2	000-025-003	Cable, Choke with Detent	1	28	000-094-098	Nut, 7/16"-24UNF - 2 Way Metering Valve	1
3	000-025-030	Cable, Throttle W/ Swivel	1	29	000-100-170	Panel, Grill - Coated	1
4	000-052-051	Quick Connect, 440 Female w/ EPDM O-Ring	1	30	000-100-310	Panel, Dash, Steel - Coated	1
5	000-052-052	Quick Connect, 660 3/8" Brass w/ EPDM O-Ring	1	31	000-131-131	Trimlok, 3/8" X 1/8" Rubber	1
6	000-052-069	Nipple, 1/8" NPT Hex	1	32	000-135-052	Regulator, Hi-Psi Snubber	1
7	000-052-073	Nipple, 3/8" NPT X 1/4" NPT Hex	1	33	000-143-126	Screw, #10-24UNC X 0.50" Lg. Hex Head	8
8	000-052-084	Elbow, 1/8" NPT Street	1	34	000-143-166	Screw, #10-24UNC X 0.375" Lg. Hex Head	2
9	000-052-088	Elbow, 1/4" FPT X FPT	1	35	000-143-171	Screw, #10-24UNC X 1.25" Lg. Hex Head	4
10	000-052-090	Tee, 1/4" NPT Branch M-F-F	1	36	000-149-025	Thermostat, Bulb and Capillary	1
11	000-052-096	Insert, #F23 (1/8" FPT X 3/16" Barb)	1	37	000-157-040	Switch, 20 Amp Rocker	1
12	000-052-099	Insert, #26 (1/8" NPT X 3/8" Barb)	3	38	000-157-131	Switch, 3 Way Speed Control	1
13	000-052-104	Insert, #66 (3/8" NPT X 3/8" Barb)	1	39	000-169-064	Valve, 3/8" NPT Full Port Ball	1
14	000-052-105	Insert, #68 (3/8" NPT X 1/2" Barb)	2	40	000-169-160	Valve, Chemical Metering	1
15	000-052-272	Cup, Gravity Feed Oil Blower Lube Port	1	41	000-169-0171	Valve, 3-Way Ball O-Ring Style	1
16	000-052-527	Nipple, 1/4" SAE X 1/4" NPT	1	42	000-169-236	Valve, Differential	1
17	000-052-528	Nipple, 3/8" M Jic X 3/8" NPT	1	43	000-174-001	Washer, #10 Flat	14
18	000-052-530	Nipple, 1/4" SAE X 1/8" NPT	1	44	000-174-003	Washer, 1/4" Flat	4
19	000-052-531	Elbow, 1/8" NPT X 1/4" SAE	1	45	000-174-007	Washer, 1/2" Flat	3
20	000-052-532	Elbow, 1/4" SAE X 1/4" NPT	1	46	000-174-008	Washer, 5/8" Flat	4
21	000-074-007	Gauge, Pressure 0 -1,500 psi	1	47	000-174-014	Washer, #10 Lock	2
22	000-074-017	Gauge, 30" Hg. Vacuum	1	48	000-174-030	Washer, 5/8" I.D. X 7/8" O.D. X 0.010" Thk	1
23	000-074-030	Meter, Chemical Flow Raw	1	49	000-174-032	Washer, 3/8" Flat	2
24	000-074-170	Meter, Rectangular Hour w/o Bezel	1	50	000-174-038	Washer, 7/16" Flat SAE	1
25	000-081-415	Label Set, Boxxer 318	1	51	000-174-058	Washer, 21/32" I.D. X 27/32" O.D. Nylon	1
26	000-094-009	Nut, 1/4"-20UNC Nylock	4	52	000-174-062	Washer, 1/2" I.D. X 3/4" O.D. X 0.010" Thk	1

Figure 8-20. Differential Check Valve Assembly
000-169-236 Rev. B

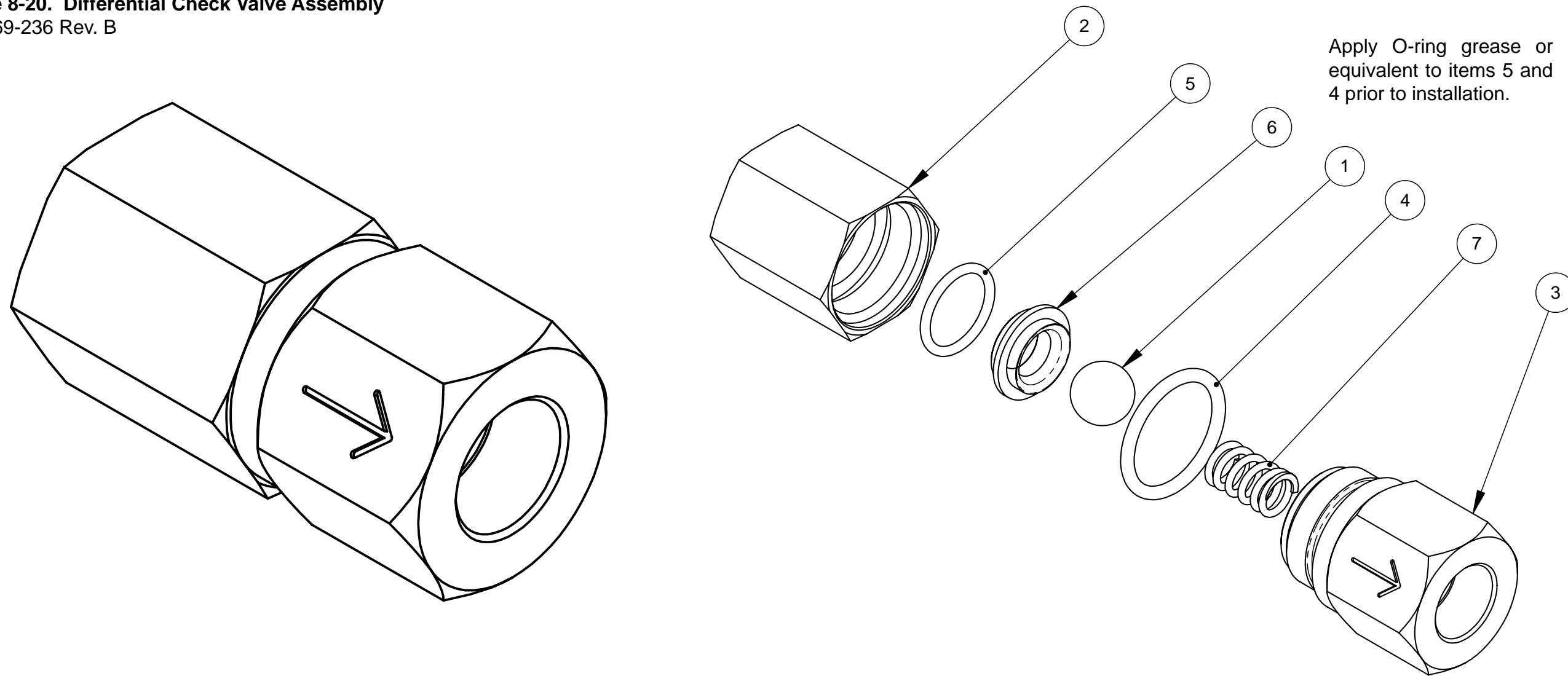

Differential Check Valve Assembly Parts List

Item	Part Number	Description	Qty
1	000-005-012	Ball, 0.500 Diameter Stainless Steel	1
2	000-107-258	Body, Differential Check Valve	1
3	000-106-180	Cap, Differential Check Valve	1
4	000-097-056	O-Ring, Check Valve Plug, An Size	1

Item	Part Number	Description	Qty
5	000-097-054	O-Ring, Chemical Pump Valve	1
6	000-148-012	Seat, Differential Check Valve	1
7	000-155-106	Spring, Differential Check Valve	1

Figure 8-21. By-Pass Valve Assembly
610-009-729 Rev. B

NOTICE

See Figure 8-1 for adhesive/sealant information.

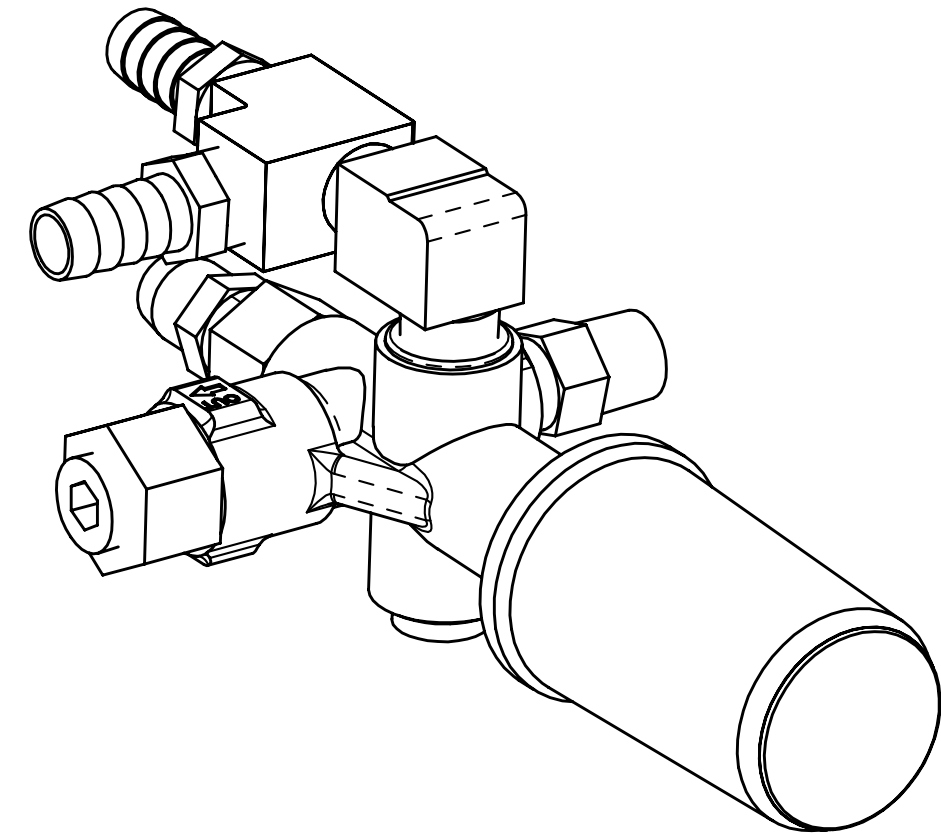

By-Pass Valve Assembly Parts List

Item	Part Number	Description	Qty
1	000-052-086	Elbow, 3/8" NPT Street	1
2	000-052-105	Insert, #68 (3/8" NPT X 1/2" Barb)	2
3	000-052-128	Nipple, 3/8" MPT X 3/8" SAE Flare	1
4	000-052-074	Nipple, 3/8" NPT Hex	1
5	000-106-008	Plug, 3/8" NPT Allen Head	2
6	000-052-023	Tee, 3/8" NPT Male Street	1
7	000-169-351	Valve, Pressure Regulator-Modified *	1

NOTICE

* Order P/N 000-078-582 for the valve repair kit.

Figure 8-22. Orifice Assembly
610-021-729

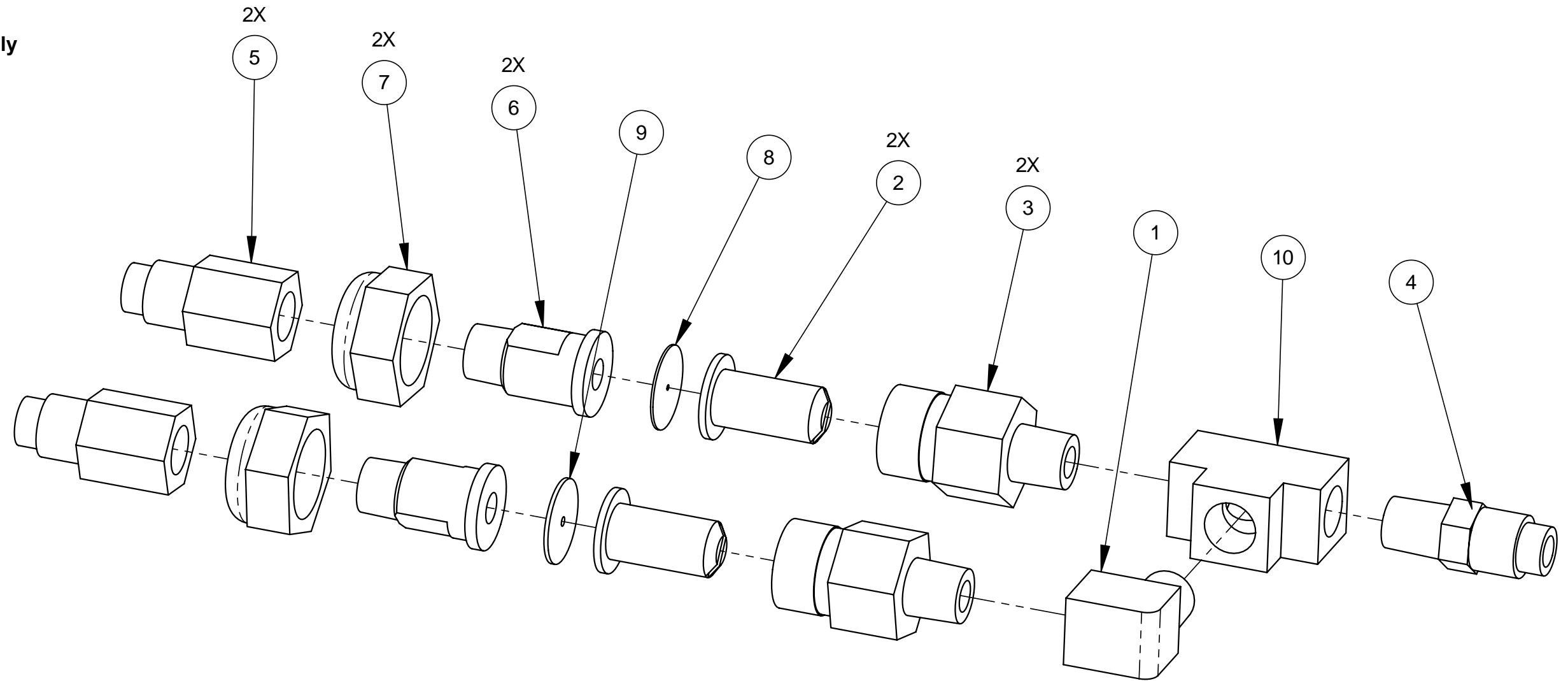

Orifice Assembly Parts List

Item	Part Number	Description	Qty
1	000-052-084	Elbow, 1/8" NPT Street	1
2	000-049-052	Filter Cartridge, 1/4" Brass	2
3	000-052-153	Housing, Stabilizer Nozzle	2
4	000-052-530	Nipple, 1/4" SAE X 1/8" NPT	1
5	000-052-586	Nipple, 1/8" FPT X 1/4" SAE	2
6	000-052-582	Nipple, Tee Jet Style Collar X 1/8" NPT	2
7	000-094-028	Nut, Brass Jet Assembly	2
8	000-180-010	Orifice, 0.039" Plate	1
9	000-180-024	Orifice, 0.067" Plate	1
10	000-052-092	Tee, 1/8" FPT	1

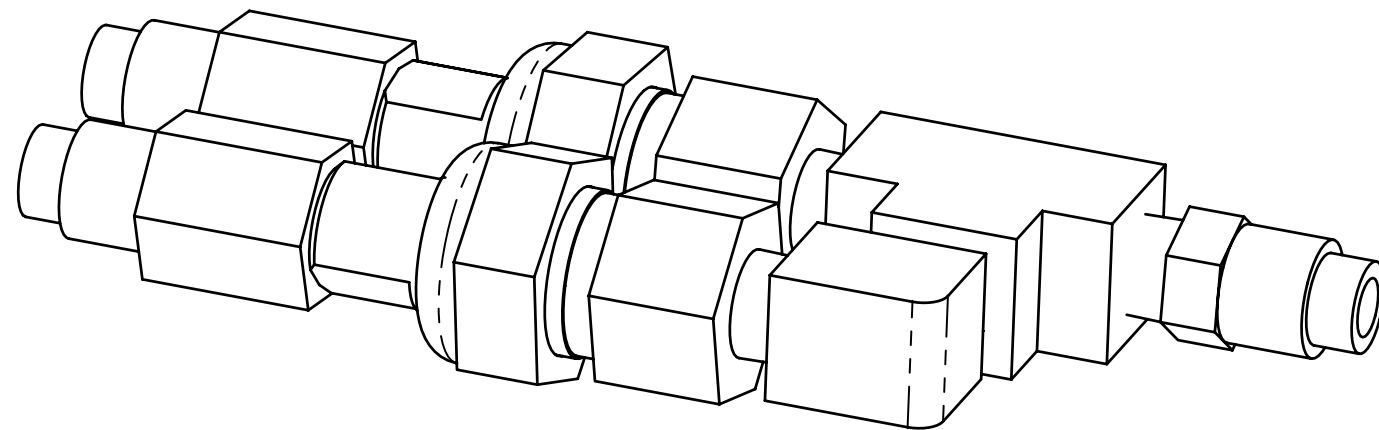
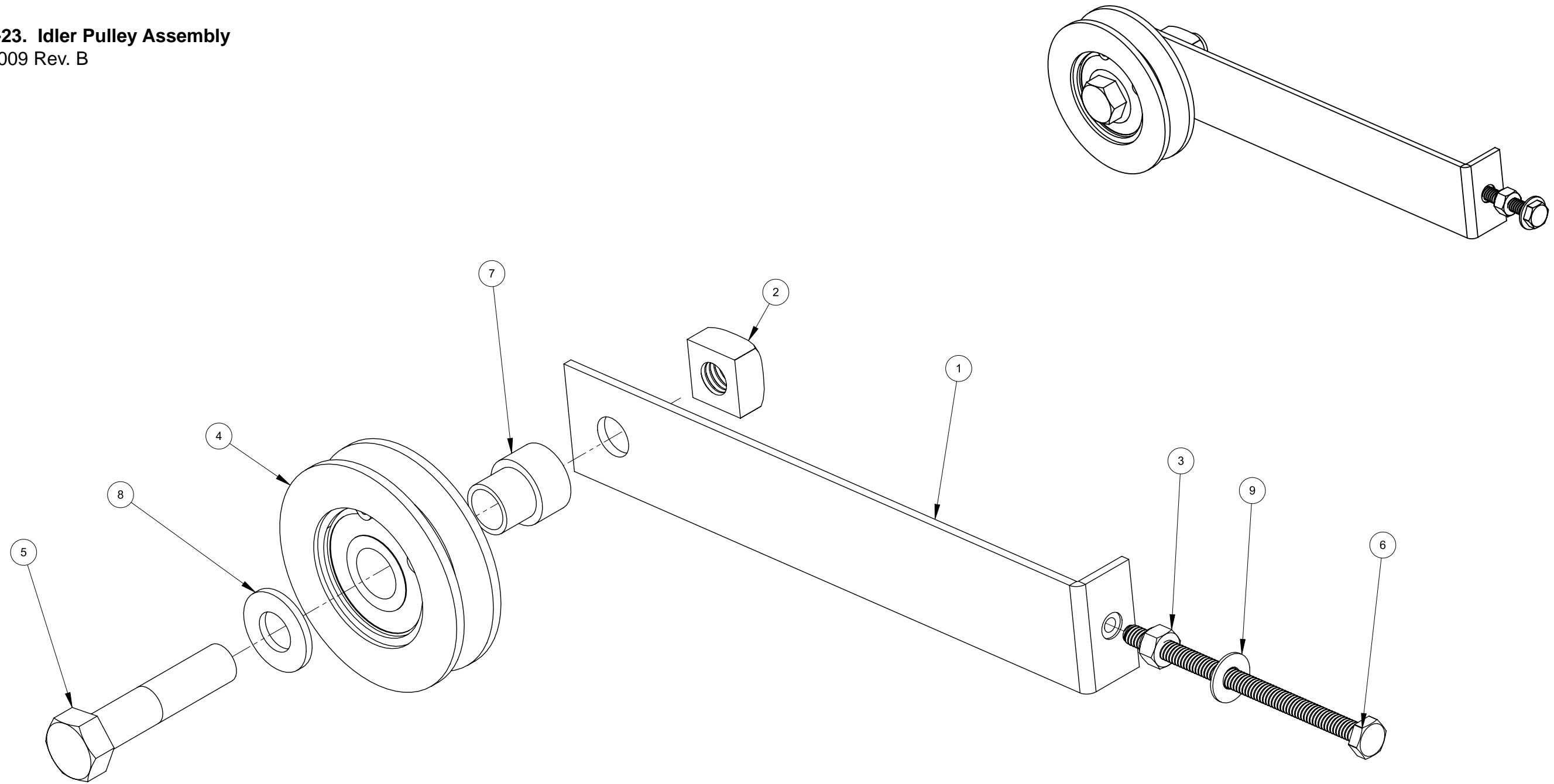

Figure 8-23. Idler Pulley Assembly
610-021-009 Rev. B



Idler Pulley Assembly Parts List

Item	Part Number	Description	Qty
1	000-015-942	Bracket, Idler Tension - Coated	1
2	000-094-119	Nut, 1/2"-13UNC Square Z/P	1
3	000-094-009	Nut, 1/4"-20UNC Nylock	1
4	000-109-093	Pulley, 3" "A" Sect. Ball Bearing Assembly	1
5	000-143-041	Screw, 1/2"-13UNC X 2.25" Lg. HHC	1

Item	Part Number	Description	Qty
6	000-143-376	Screw, 1/4"-20UNC X 4.00" Lg. S/S- Full Thread	1
7	000-154-128	Spacer, Pump Idler Mounting - Raw	1
8	000-174-012	Washer, 1/2 SAE H/D	1
9	000-174-003	Washer, 1/4" Flat	1

Figure 8-24. Exhaust Assembly
610-013-729 Rev. B

Exhaust Assembly Parts List

Item	Part Number	Description	Qty
1	000-001-116	Adapter, N1.50" F Slip to Flare	1
2	000-033-068	Clamp, 1-1/2" Exhaust	1
3	000-105-181	Flange, Ø1.50" Exhaust Donut - Coated	1
4	000-057-177	Gasket, Exhaust Donut 1.50"	1
5	000-057-212	Gasket, Half Donut	1
6	000-057-209	Gasket, Ø2.5" X 3.5" BCD	1
7	000-094-081	Nut, 5/16"-18UNC Hex 2 Way Locking	6
8	000-143-001	Screw, 1/4"-20UNC X 3/4" Lg. Hex Head	4
9	000-143-124	Screw, 5/16"-18UNC X 1.75" Lg. Hex Head	4
10	000-125-128	Tube, 1-3/8" O.D. X 1/8" Wall X 7/8" Long	1
11	000-125-156	Tube, Exhaust 6.875" Lg. w/ Flare	1
12	000-125-227	Tube, Lower Exhaust Weldment	1
13	000-125-228	Tube, Upper Exhaust Weldment	1
14	000-174-003	Washer, 1/4" Flat	4
15	000-174-049	Washer, 5/16" Flat	10

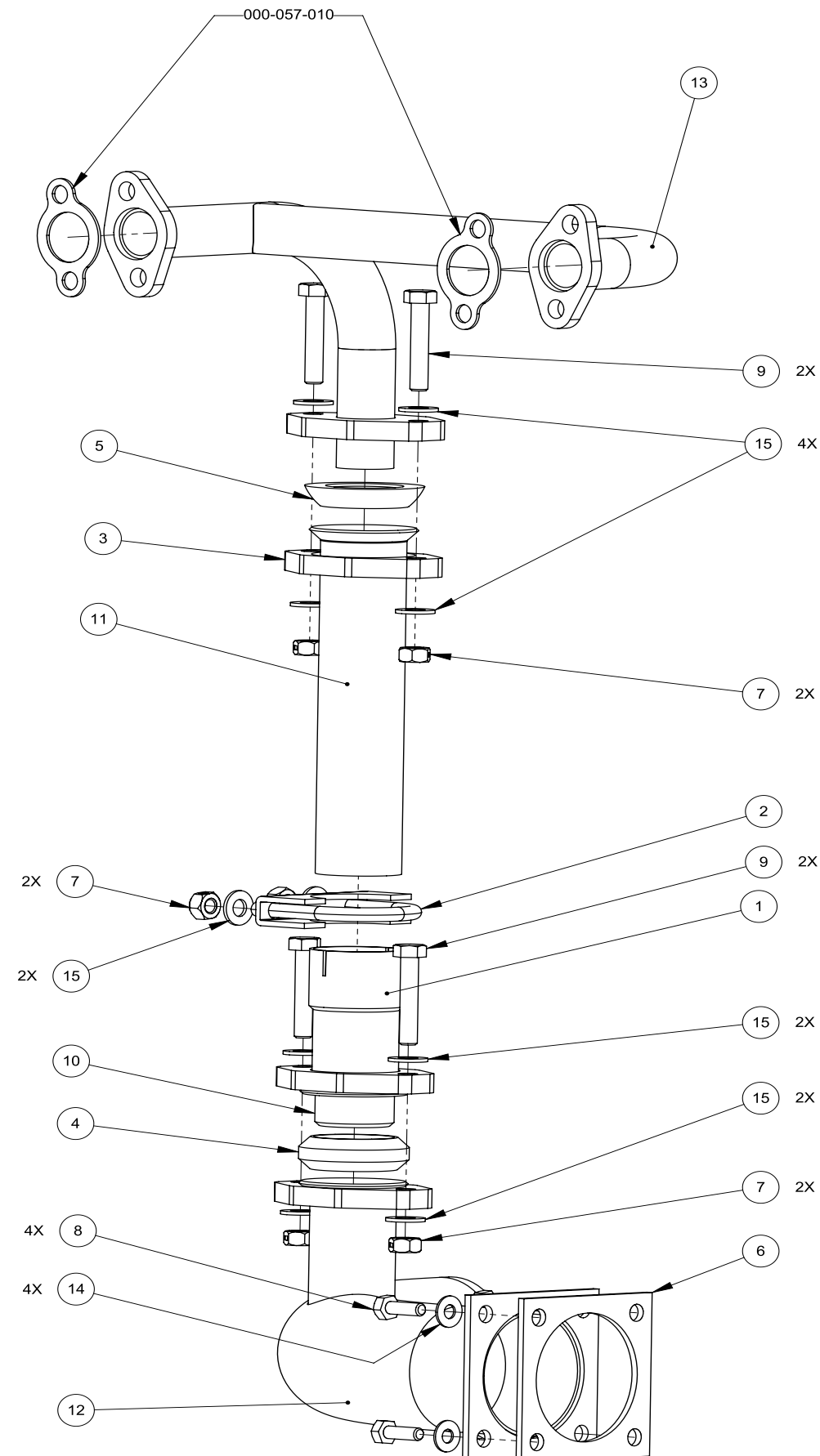
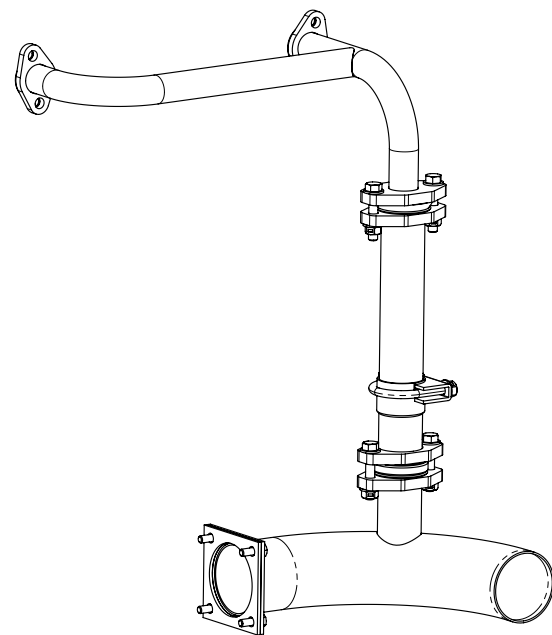

Figure 8-25. 65 Gallon Universal Recovery Tank (URT) Assembly

View 1 of 2

610-003-729 Rev. B

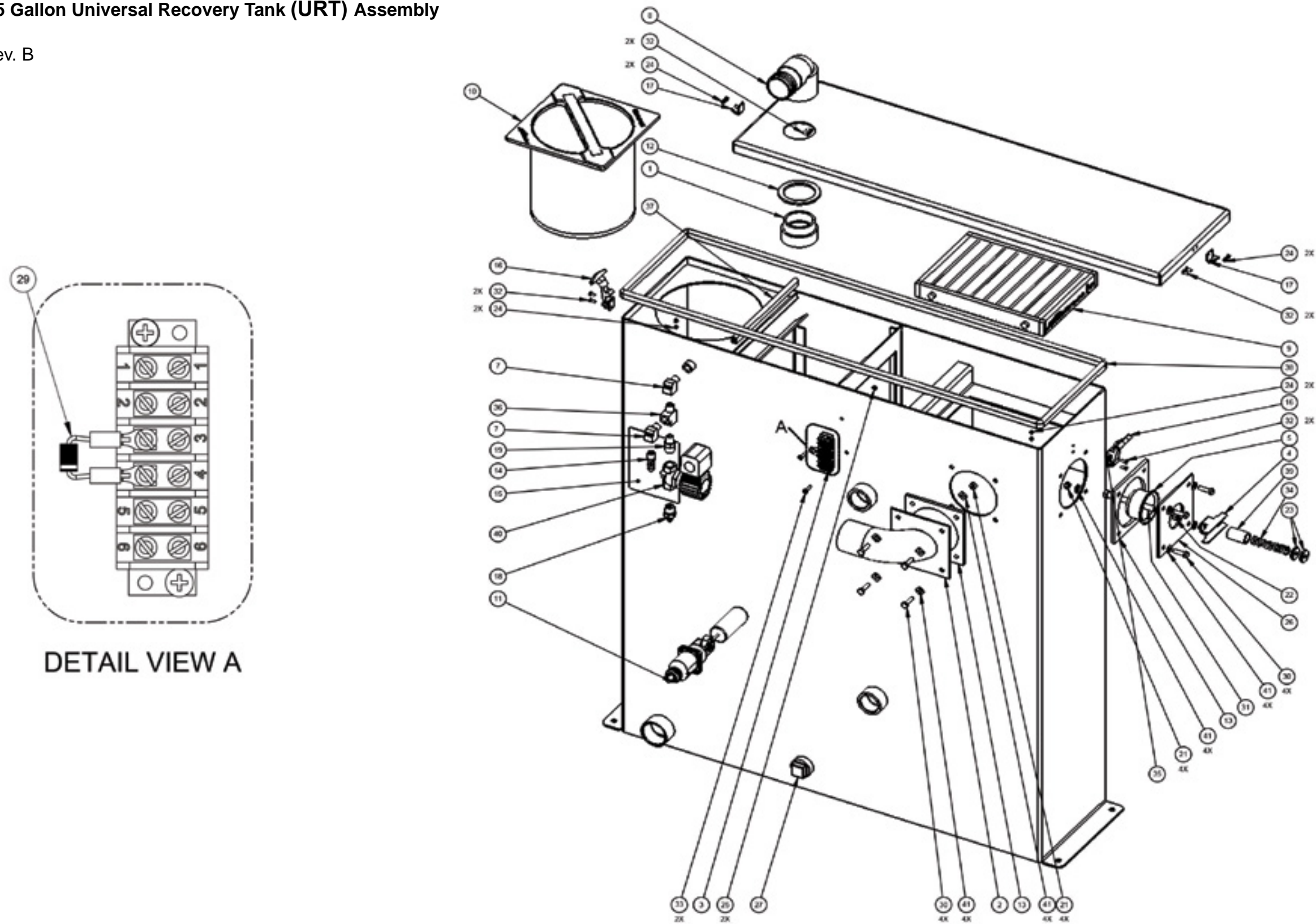
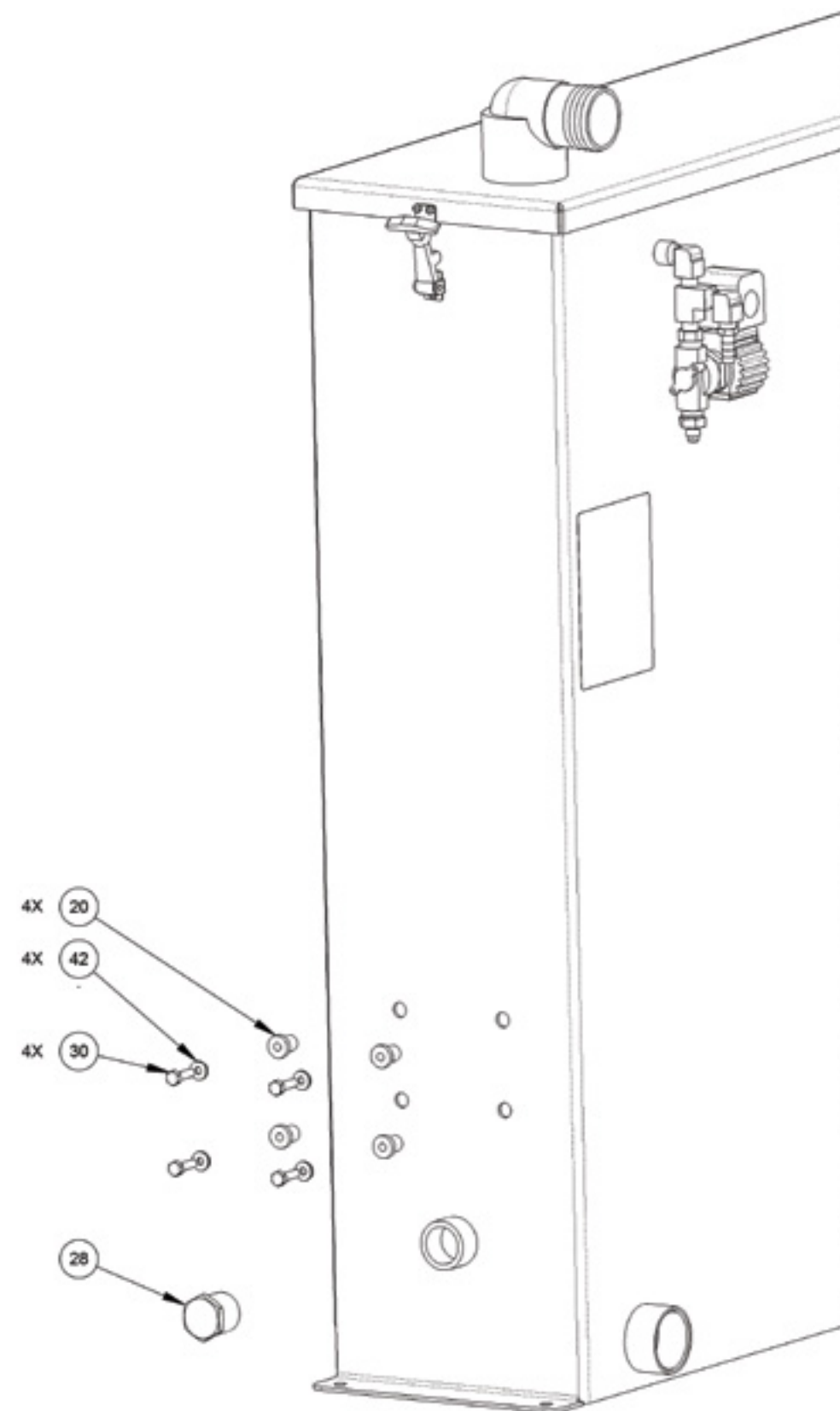
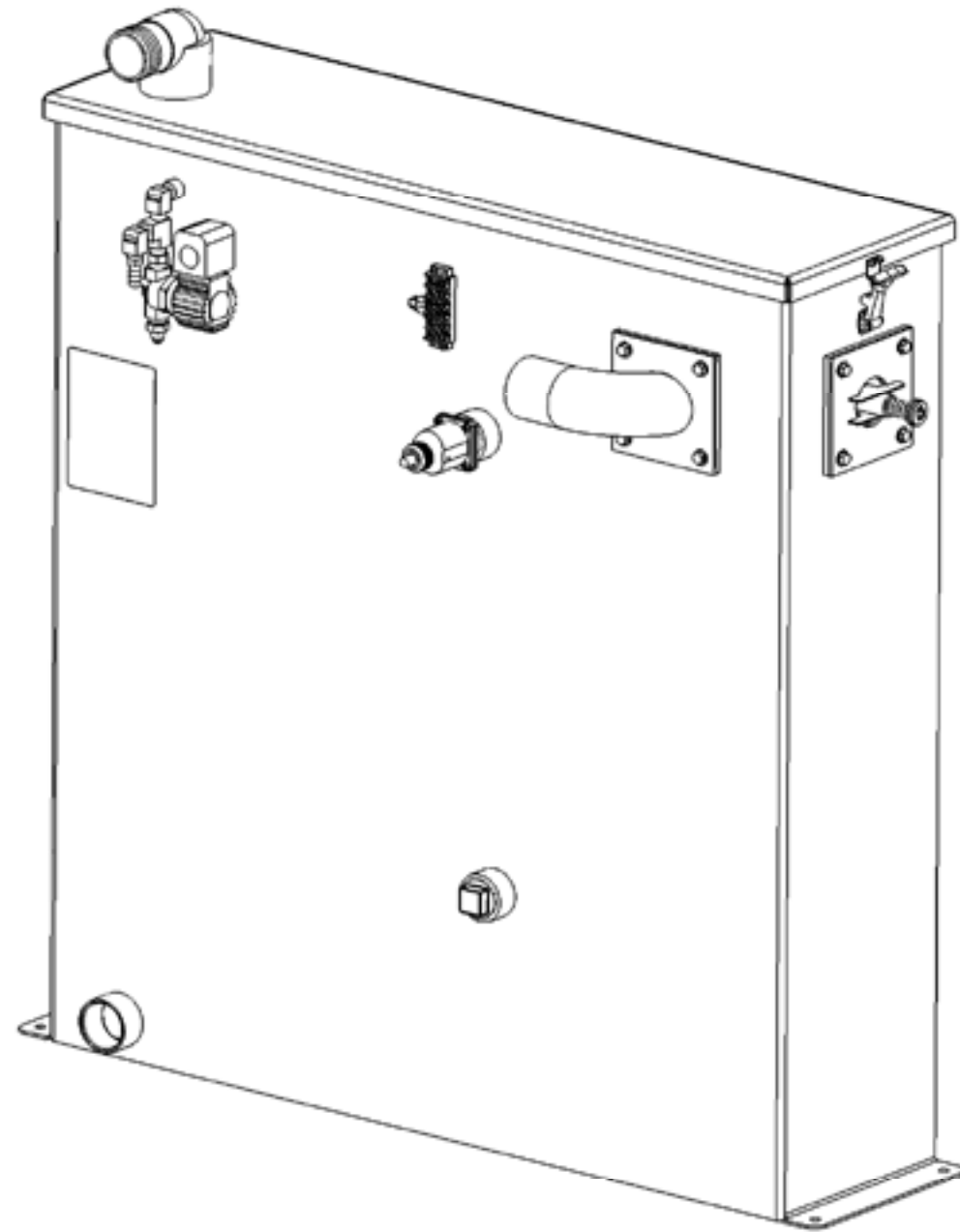

Figure 8-26. 65 Gallon Universal Recovery Tank (URT) Assembly - View 2 of 2
610-003-729 Rev. B



65 Gallon Universal Recovery Tank (URT) Assembly Parts List

Item	Part Number	Description	Qty	Item	Part Number	Description	Qty
1	000-052-219	Adapter, 2" NPT X 2" F Slip	1	22	000-094-101	Nut, 3/8"-16 UNC Hex Jam	1
2	000-001-134	Adapter, Ø2.5" Tank X 90 Degree Blower Hose - Coated	1	23	000-094-077	Nut, 3/8"-16UNC X 1.00" O.D. Knurled	2
3	000-012-002	Block, 6 Post Terminal	1	24	000-094-063	Nut, #6-32UNC Nylock	8
4	000-015-182	Bracket, Vacuum Relief Valve - Fabricated	1	25	000-094-059	Nut, #8-32UNC Nylock	2
5	000-027-032	Cap, Spun Vacuum Relief Valve	1	26	000-105-332	Plate, Vacuum Relief Valve Mounting - Coated	1
6	000-041-459	Cover, 50 URT 1 Port - Coated	1	27	000-106-046	Plug, 1-1/4" NPT	1
7	000-052-085	Elbow, 1/4" NPT Street	2	28	000-106-049	Plug, 1" NPT Black Nylon	1
8	000-052-222	Elbow, 2" Barb X 2" FPT	1	29	000-135-051	Regulator,3 Amp 1000 PIV Diode	1
9	000-049-153	Filter, Flat - Universal Recovery Tank	1	30	000-143-002	Screw, 1/4"-20UNC X 1.00" Lg. Hex Head	12
10	000-049-155	Filter, Recovery Tank Basket - Small	1	31	000-143-198	Screw, 3/8"-16UNC X 4" Lg. Hex Head - Full Thread	1
11	000-157-091	Float, Lever Switch	1	32	000-143-165	Screw, #6-32UNC X 3/8" Lg. Button Head	8
12	000-057-015	Gasket, 1-1/2" Bulkhead Fitting	1	33	000-143-051	Screw, #8-32UNC X 3/4" Lg. Binder Head	2
13	000-057-206	Gasket, Adapter - URT	2	34	000-155-026	Spring, Vacuum Relief Valve	1
14	000-052-102	Insert, #46 (1/4" NPT X 3/8" Barb)	1	35	000-159-181	Tank, 65 Gallon Universal Recovery - Coated	1
15	000-081-332	Label, Maintenance and Lube Schedule	1	36	000-052-090	Tee, 1/4" NPT Branch M-F-F	1
16	000-086-008	Latch, Bungee	2	37	000-131-021	Trimlok, 5/8" X 1/8"	1
17	- - -	Latch, Bungee - Strike (Part of 000-086-008)	2	38	000-131-021	Trimlok, 5/8" X 1/8"	1
18	000-052-662	Nipple, 3/8" NPT X 1/4" M SAE	1	39	000125-111	Tube, Vacuum Relief Spring Guide	1
19	000-052-073	Nipple, 3/8" NPT X 1/4" NPT Hex	1	40	000-169-082	Valve, 12 Volt Solenoid 1,200 psi	1
20	000-094-113	Nut, 1/4"-20UNC Neoprene Wellnut	4	41	000-174-003	Washer, 1/4" Flat	16
21	000-094-009	Nut, 1/4"-20UNC Nylock	8	42	000-174-060	Washer, 1/4" Rubber Backed	4

Figure 8-27. 100 Gallon Universal Recovery Tank (URT) Assembly
610-003-763 Rev. A

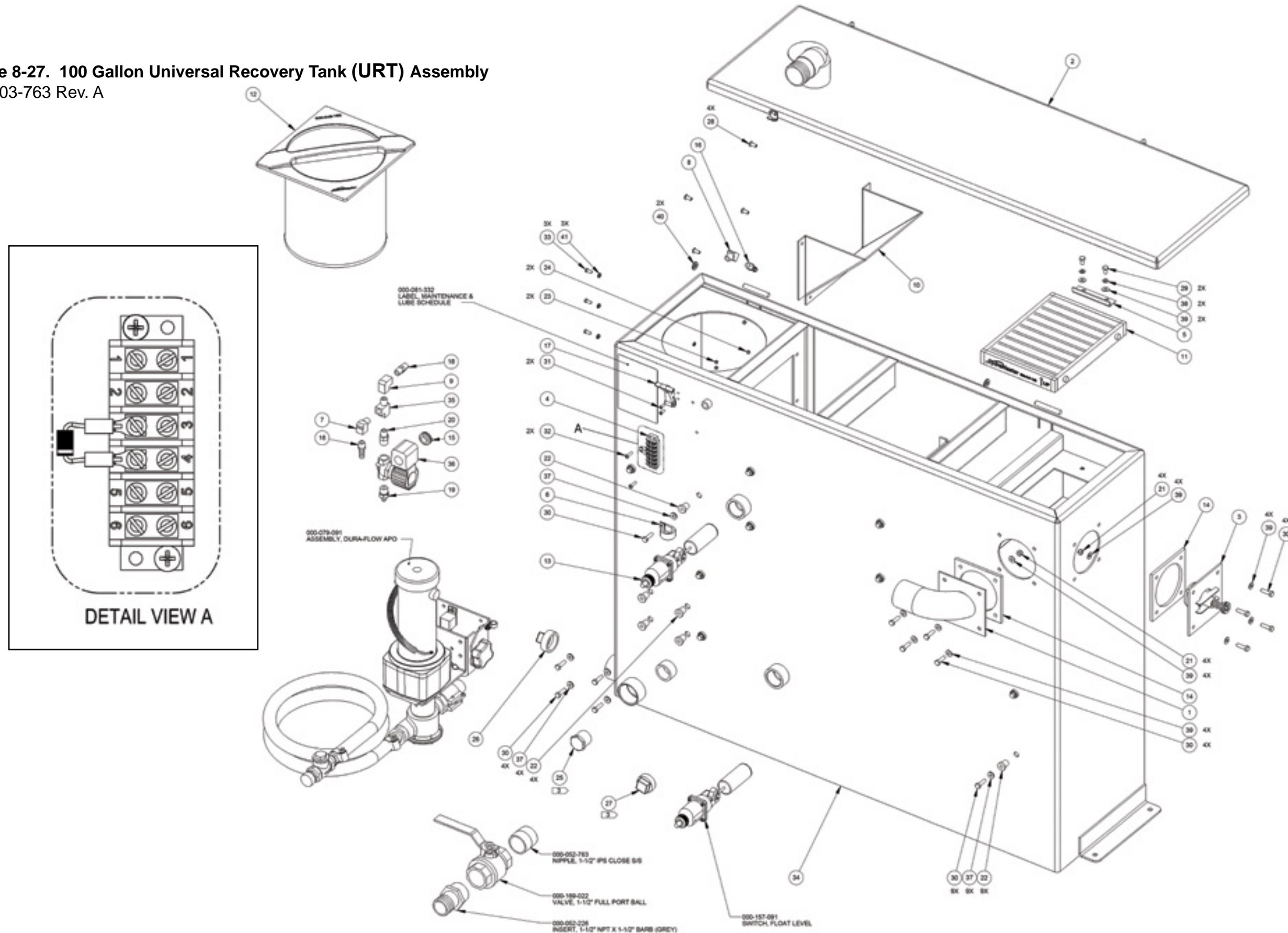

100 Gallon Universal Recovery Tank (URT) Assembly Parts List

Item	Part Number	Description	Qty
1	000-001-134	Adapter, Ø2.5" Tank X 90 Degrees Blower Hose	1
2	610-029-763	Assembly, Recovery Tank Single Port Cover	1
3	610-026-724	Assembly, Vacuum Relief Valve - URT	1
4	000-012-002	Block, 6 Post Terminal	1
5	000-015-932	Bracket, Flat Filter Securing - Uncoated	1
6	000-033-057	Clamp, 1" Cushion Loop	1
7	000-052-085	Elbow, 1/4" NPT Street	1
8	000-052-082	Elbow, 1/4" NPT Street X 45 Degrees	1
9	000-052-088	Elbow, 1/4" FPT	1
10	000-049-154	Filter, Air Deflector, URT - Fabricated	1
11	000-049-153	Filter, Flat - URT	1
12	000-049-152	Filter, Recovery Tank Basket	1
13	000-157-091	Float, Lever Switch	1
14	000-057-206	Gasket, Adapter - URT	2
15	000-060-002	Grommet, Large Wiring	1
16	000-052-102	Insert, #46 (1/4" NPT X 3/8" Barb)	2
17	000-086-008	Latch, Bungee	1
18	000-052-071	Nipple, 1/4" NPT Hex	1
19	000-052-662	Nipple, 3/8" NPT X 1/4" M SAE	1
20	000-052-073	Nipple, 3/8" NPT X 1/4" NPT Hex	1
21	000-094-009	Nut, 1/4"-20UNC Nylock	8

Item	Part Number	Description	Qty
22	000-094-113	Nut, 1/4"-20UNC Neoprene Wellnut	14
23	000-094-063	Nut, #6-32UNC Hex Nylock	2
24	000-094-059	Nut, #8-32UNC Nylock	2
25	000-106-049	Plug, 1" NPT Black Nylon	1
26	000-106-019	Plug, 1-1/2" NPT	1
27	000-106-046	Plug, 1-1/4" NPT	1
28	000-140-023	Rivet, AB8-6A Aluminum Pop	4
29	000-143-333	Screw, 1/4"-20UNC X 0.50" Lg. Hex Head	2
30	000-143-002	Screw, 1/4"-20UNC X 1.00" Lg. Hex Head	22
31	000-143-539	Screw, #6-32UNC X 0.50" Lg. Button Head	2
32	000-143-051	Screw, #8-32UNC X 3/4" Lg. Binder Head	2
33	000-143-126	Screw, #10-24UNC X 0.50" Lg. Hex Head	3
34	000-159-129	Tank, 100 Gallon Universal Recovery - Coated	1
35	000-052-090	Tee, 1/4" NPT Branch M-F-F	1
36	000-169-082	Valve, 12 Volt Solenoid 1,200 psi	1
37	000-174-060	Washer, 1/4" Rubber Backed	14
38	000-174-019	Washer, 1/4" Lock	2
39	000-174-003	Washer, 1/4" Flat	18
40	000-174-029	Washer, 3/8" Rubber Backed	2
41	000-174-036	Washer, #10 Flat Rubber Backed	3

Figure 8-28. 100 Gallon Universal Recovery Tank (URT) Cover Assembly
610-029-763 Rev. A

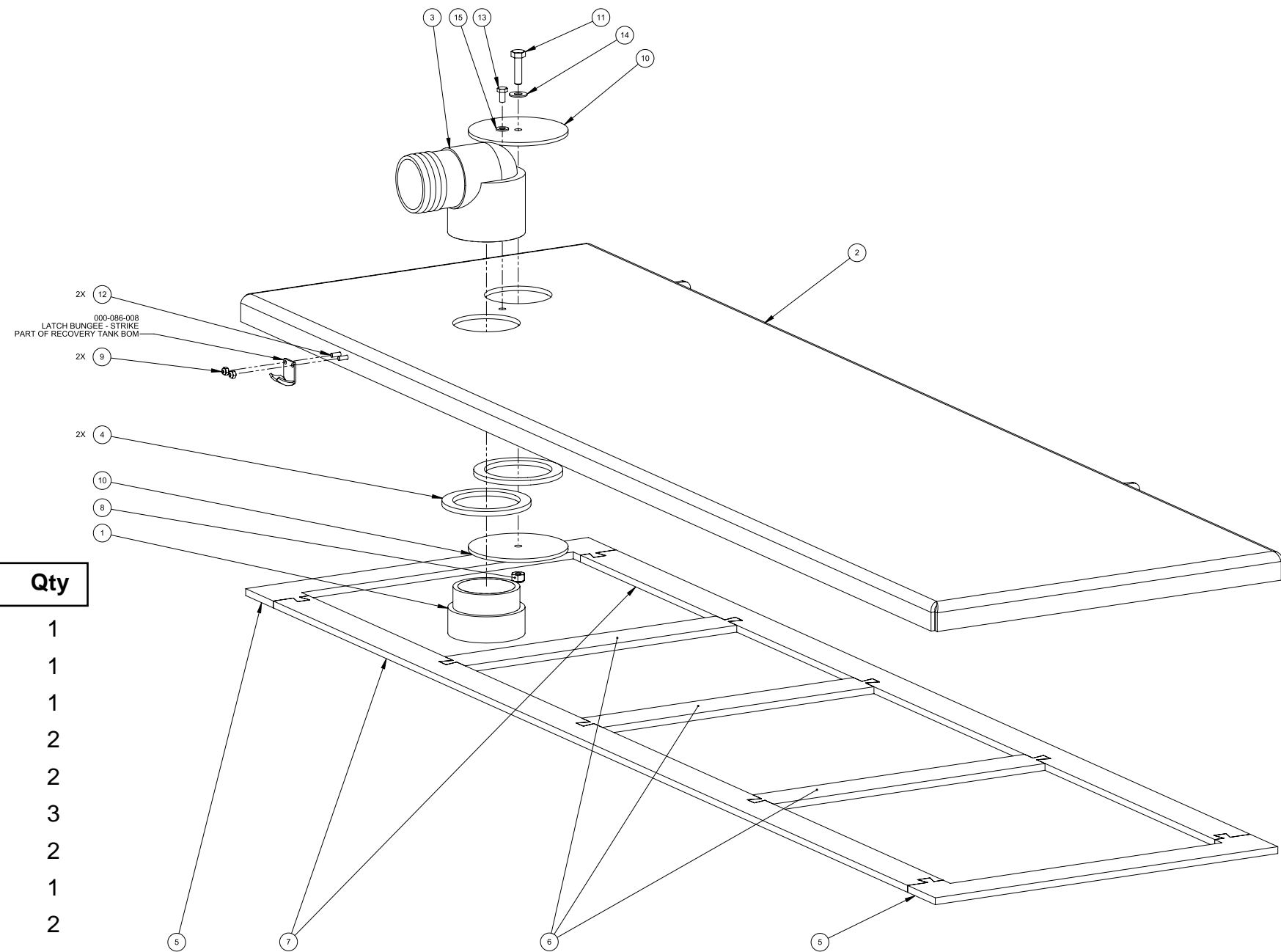
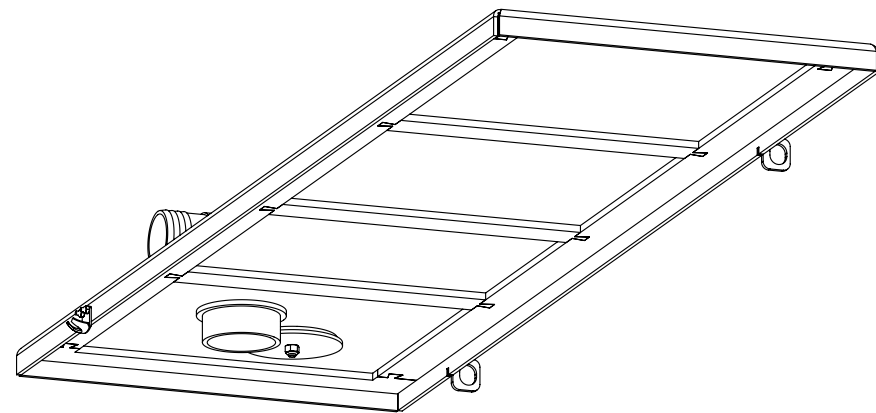

**100 Gallon Universal Recovery Tank (URT)
Cover Assembly Parts List**

Item	Part Number	Description	Qty
1	000-052-219	Adapter, 2" NPT X 2" F Slip	1
2	000-041-447	Cover, 100 URT 2 Port - Coated	1
3	000-052-222	Elbow, 2" Barb X 2" FPT	1
4	000-057-015	Gasket, 1-1/2" Bulkhead Fitting	2
5	000-057-202	Gasket, End - Recovery Tank Cover	2
6	000-057-203	Gasket, Middle - Recovery Tank Cover	3
7	000-057-205	Gasket, Side - Recovery Tank Cover	2
8	000-094-009	Nut, 1/4"-20UNC Nylock	1
9	000-094-063	Nut, #6-32UNC Hex Nylock	2
10	000-105-546	Plate, Port Cover - Coated	2
11	000-143-002	Screw, 1/4"-20UNC X 1.00" Lg. Hex Head	1
12	000-143-539	Screw, #6-32UNC X 0.50" Lg. Button Head	2
13	000-143-166	Screw, #10-24UNC X 0.375" Lg. Hex Head	1
14	000-174-003	Washer, 1/4" Flat	1
15	000-174-001	Washer, #10 Flat	1

Figure 8-29. Vacuum Relief Valve Assembly
610-026-724 Rev. B

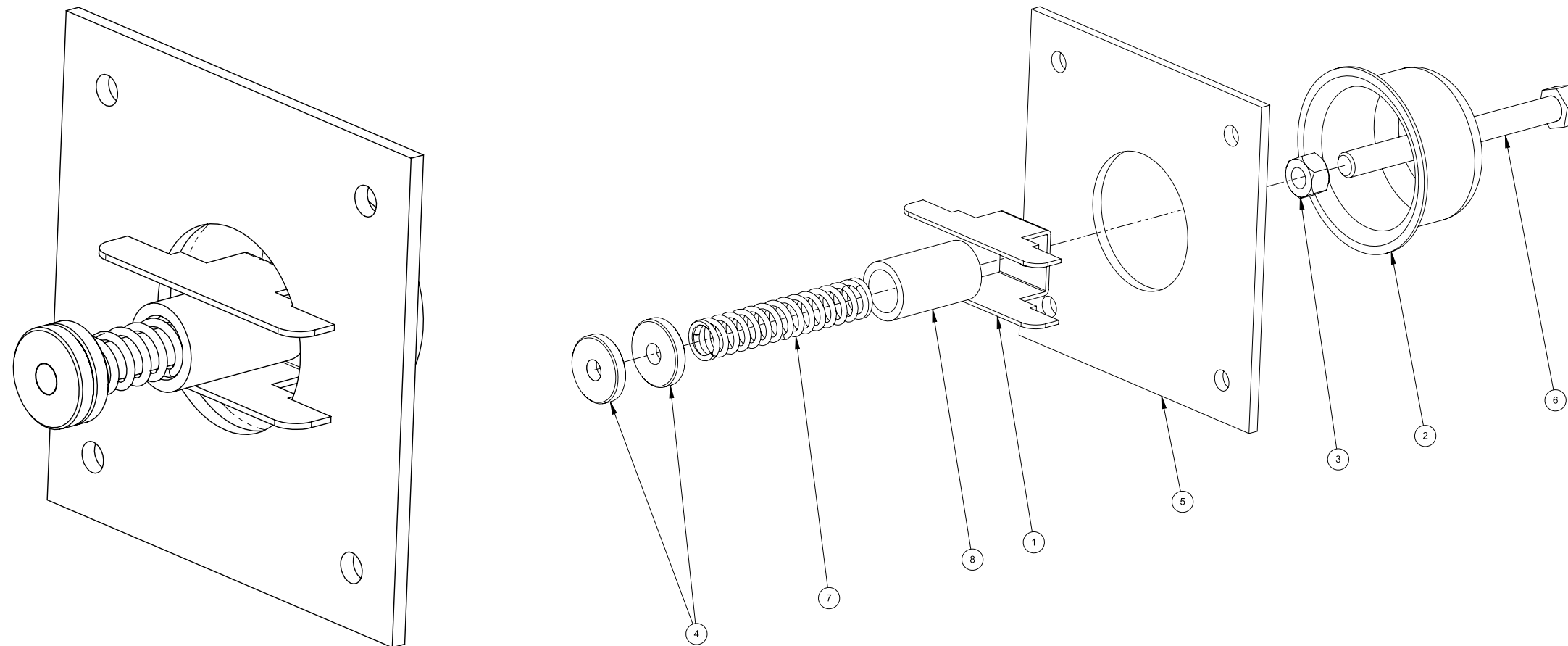

Vacuum Relief Valve Assembly Parts List

Item	Part Number	Description	Qty
1	000-015-182	Bracket, Vacuum Relief Valve - Fabricated	1
2	000-027-032	Cap, Spun Vacuum Relief Valve	1
3	000-094-101	Nut, 3/8"-16 UNC Hex Jam	1
4	000-094-077	Nut, 3/8"-16UNC X 1.00" O.D. Knurled	2
5	000-105-332	Plate, Vacuum Relief Valve Mounting - Coated	1
6	000-143-198	Screw, 3/8"-16UNC X 4" Lg. Hex Head - Full Thread	1
7	000-155-026	Spring, Vacuum Relief Valve	1
8	000-125-111	Tube, Vacuum Relief Spring Guide	1

Figure 8-30. 70 Gallon
Fresh Water Tank (FWT) Assembly -
View 1 of 2
000-163-212

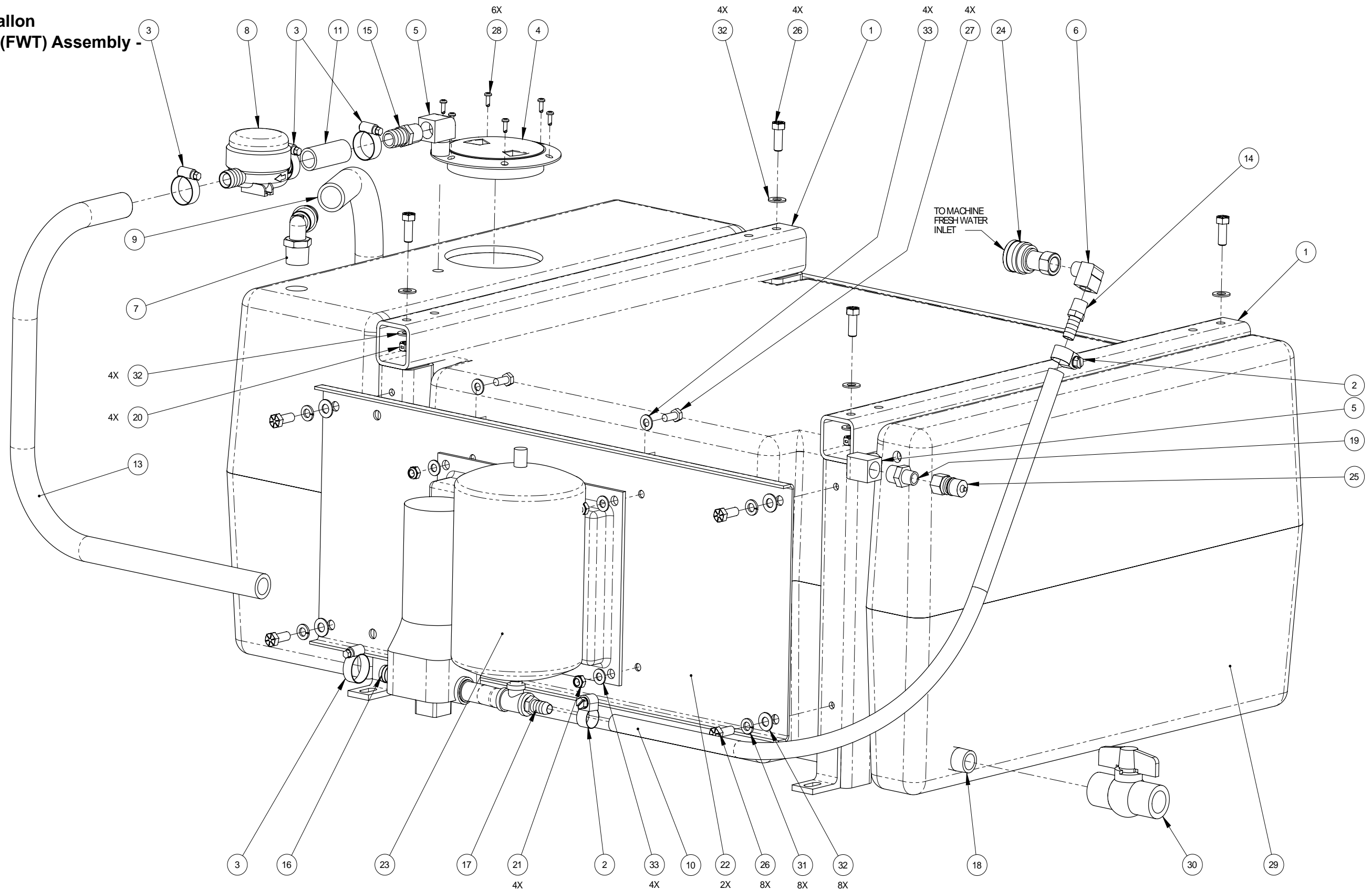

**Figure 8-31. 70 Gallon
Fresh Water Tank (FWT) Assembly
View 2 of 2
000-163-212**

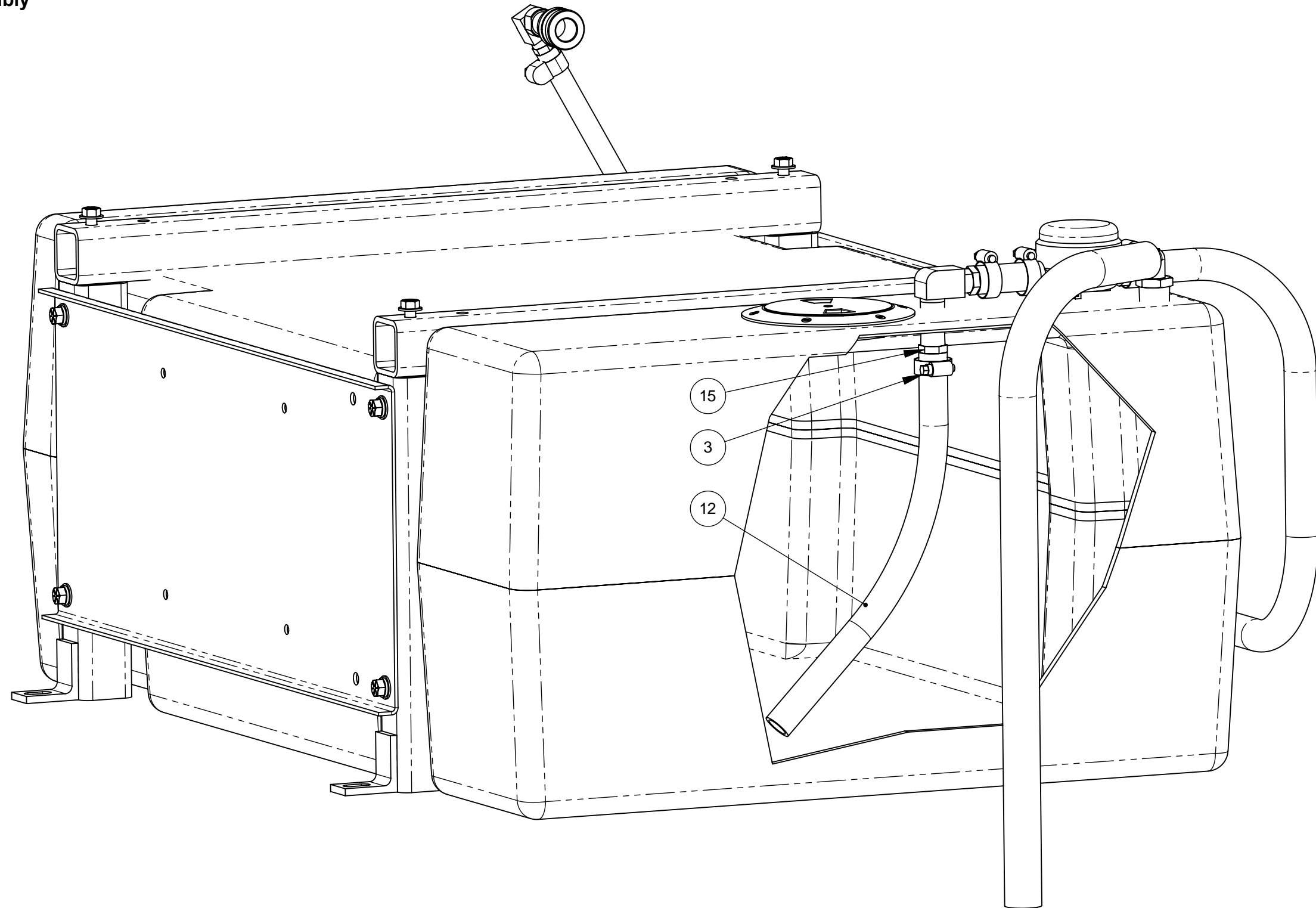

70 Gallon Fresh Water Tank (FWT) Assembly Parts List

Item	Part Number	Description	Qty	Item	Part Number	Description	Qty
1	000-015-1238	Bracket, 70 FWT Mounting - Coated	2	18	000-052-326	Nipple, 3/4" NPT Close	1
2	000-033-004	Clamp, Size #6 Mini Hose	2	19	000-052-075	Nipple, 3/8" NPT X 1/2" NPT	1
3	000-033-029	Clamp, Size #12 Hose	5	20	000-094-015	Nut, 3/8"-16UNC Hex 2-Way Locking	4
4	000-041-365	Cover, 4" Round	1	21	000-094-038	Nut, 5/16"-18UNC Nylock	4
5	000-052-087	Elbow, 1/2" NPT Street	2	22	000-105-668	Plate, Side - Coated	2
6	000-052-086	Elbow, 3/8" NPT Street	1	23	000-111-170	Pump, Flojet w/ Bladder 40 psi Fresh Water	1
7	000-052-348	Elbow, 3/4" NPT X 1" Hose	1	24	000-052-053	Quick Connect, 3/8 Female	1
8	- - -	Filter, Flojet Pump (Comes w/ 000-111-170)	1	25	000-052-052	Quick Connect, 660 3/8" Brass w/ EPDM O-Ring	1
9	000-068-964	Hose, 1" I.D. Rubber X 36" Lg. - Red	1	26	000-143-018	Screw, 3/8"-16UNC X 1" Lg. Hex Head - Grade 8	12
10	000-068-975	Hose, 1/2" I.D. Rubber X 32" Lg.	1	27	000-143-012	Screw, 5/16"-18UNC X 3/4" Lg.	4
11	000-068-973	Hose, 3/4" I.D. Rubber X 2.5" Lg.	1	28	000-143-314	Screw, #8 X 1/2" Lg. Pan Head	6
12	000-068-965	Hose, 3/4" I.D. Rubber X 16" Lg.	1	29	000-159-182	Tank, 70 Gallon Fresh Water Rotomolded	1
13	000-068-974	Hose, 3/4" I.D. Rubber X 30" Lg.	1	30	000-169-202	Valve, 3/4" FPT Ball Valve	1
14	000-052-105	Insert, #68 (3/8" NPT X 1/2" Barb)	1	31	000-174-021	Washer, 3/8" Lock	8
15	000-052-129	Insert, #812, 1/2NPT X 3/4 Hose	2	32	000-174-005	Washer, 3/8" Flat	16
16	- - -	Insert, Flojet Pump Inlet (Comes w/ 000-111-170)	1	33	000-174-049	Washer, 5/16" Flat	8
17	- - -	Insert, Flojet Pump Outlet (Comes w/ 000-111-170)	1				

Figure 8-32. Dura-Flow APO 90 Degree Assembly
000-079-099 Rev. D

NOTICE

See Figure 8-1 for adhesive/sealant information.

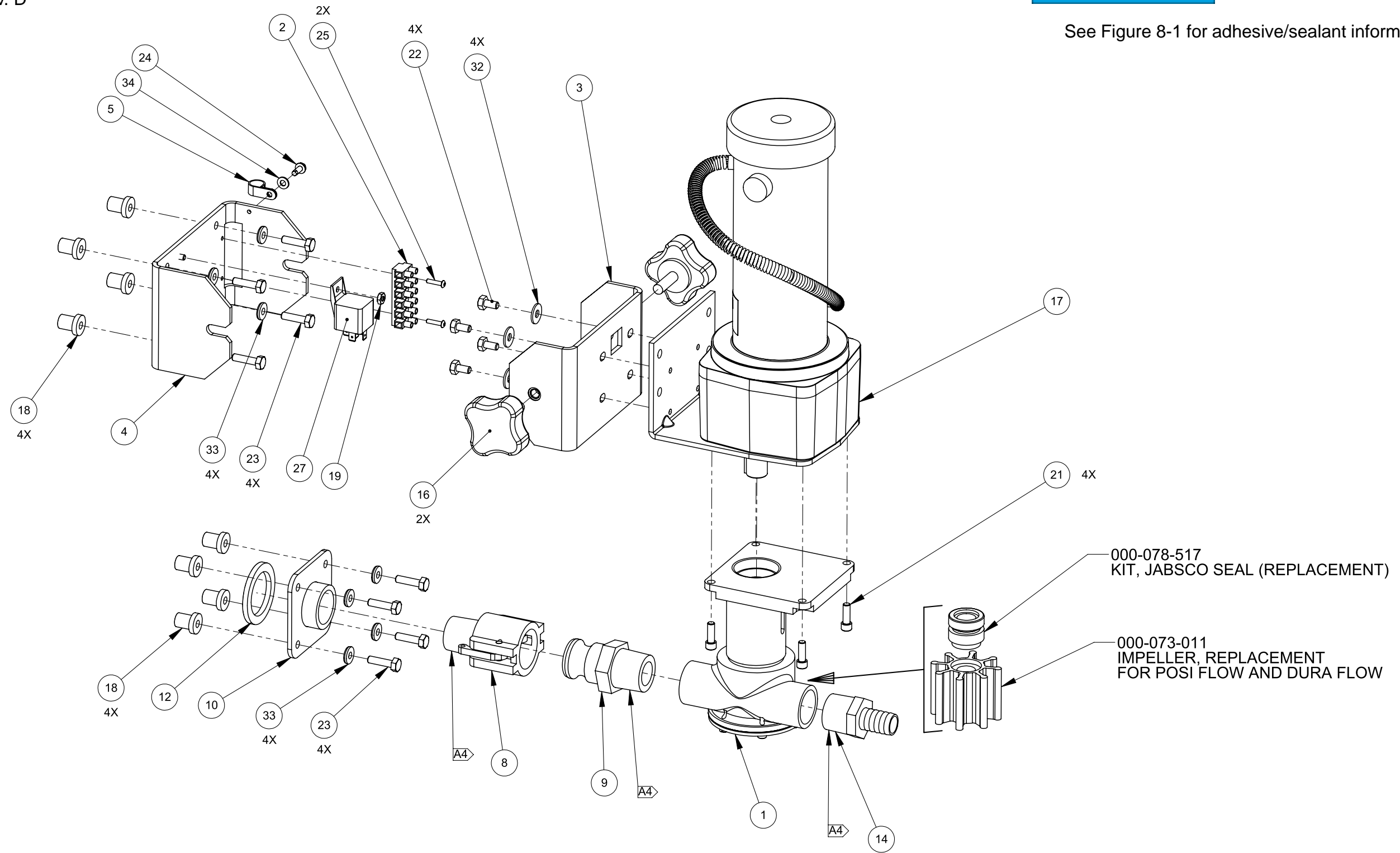

Dura-Flow APO 90 Degree Assembly Parts List

Item	Part Number	Description	Qty
1	000-111-169	Assembly, APO Pump - Jabsco	1
2	000-012-011	Block, 6 Post Terminal	1
3	000-015-891	Bracket, APO Clamp - Fabricated	1
4	000-015-890	Bracket, Tank Mounted APO Support - Fabricated	1
5	000-033-022	Clamp, 1/2" Nylon Hose	1
6	000-037-048	Conn 2 Pole Female Water Tight	1
7	000-037-033	Conn 22 Pink Butt	2
8	000-052-724	Fitting, 1" NPT Cam Lock - Banjo 100B	1
9	000-052-723	Fitting, 1" NPT Cam Lock - Banjo 100F	1
10	000-052-725	Fitting, APO Bulkhead - Weldment	1
11	000-157-090	Float, Lever Switch	1
12	000-057-192	Gasket, APO Bulkhead	1
13	000-063-021	Harness, 1/4" Split Wire Loom	5Ft
14	000-052-654	Insert, #1612 (1" NPT X 3/4" Barb)	1
15	000-079-049	Kit, APO Connection	1
16	000-061-131	Knob, Handle - RDM	2
17	000-091-043	Motor Assembly - APO	1

Item	Part Number	Description	Qty
18	000-094-113	Nut, 1/4"-20UNC Neoprene Wellnut	8
19	000-094-027	Nut, #10-24UNC Hex	1
20	000-135-051	Regulator, 3 Amp 1000 PIV Diode	1
21	000-143-566	Screw, 1/4"-28UNF X 0.75" Lg. Socket Head	4
22	000-143-074	Screw, 1/4"-20UNC X 0.50" Lg. Hex Head Self-Tapping	4
23	000-143-002	Screw, 1/4"-20UNC X 1.00" Lg. Hex Head	8
24	000-143-310	Screw, 10-32 X 1/2" HXSLHD Self Tapping	1
25	000-143-532	Screw, #6-32UNC X 5/8" Lg. Socket Head	2
26	000-147-030	Seal Water Tight Wire Connector	2
27	000-157-022	Switch, Relay	1
28	000-037-022	Term 10 AWG Fully Insulated Female	3
29	000-037-012	Term Fully Insulated Female Q	1
30	000-037-050	Term Male Pin 4 Pole Water Tight	2
31	000-162-001	Tie, Wrap 4 Nylon	4
32	000-174-002	Washer, 1/4" Flat	4
33	000-174-060	Washer, 1/4" Rubber Backed	8
34	000-174-001	Washer, #10 Flat	1

Figure 8-33. APO Pump Assembly
000-111-169 Rev. D

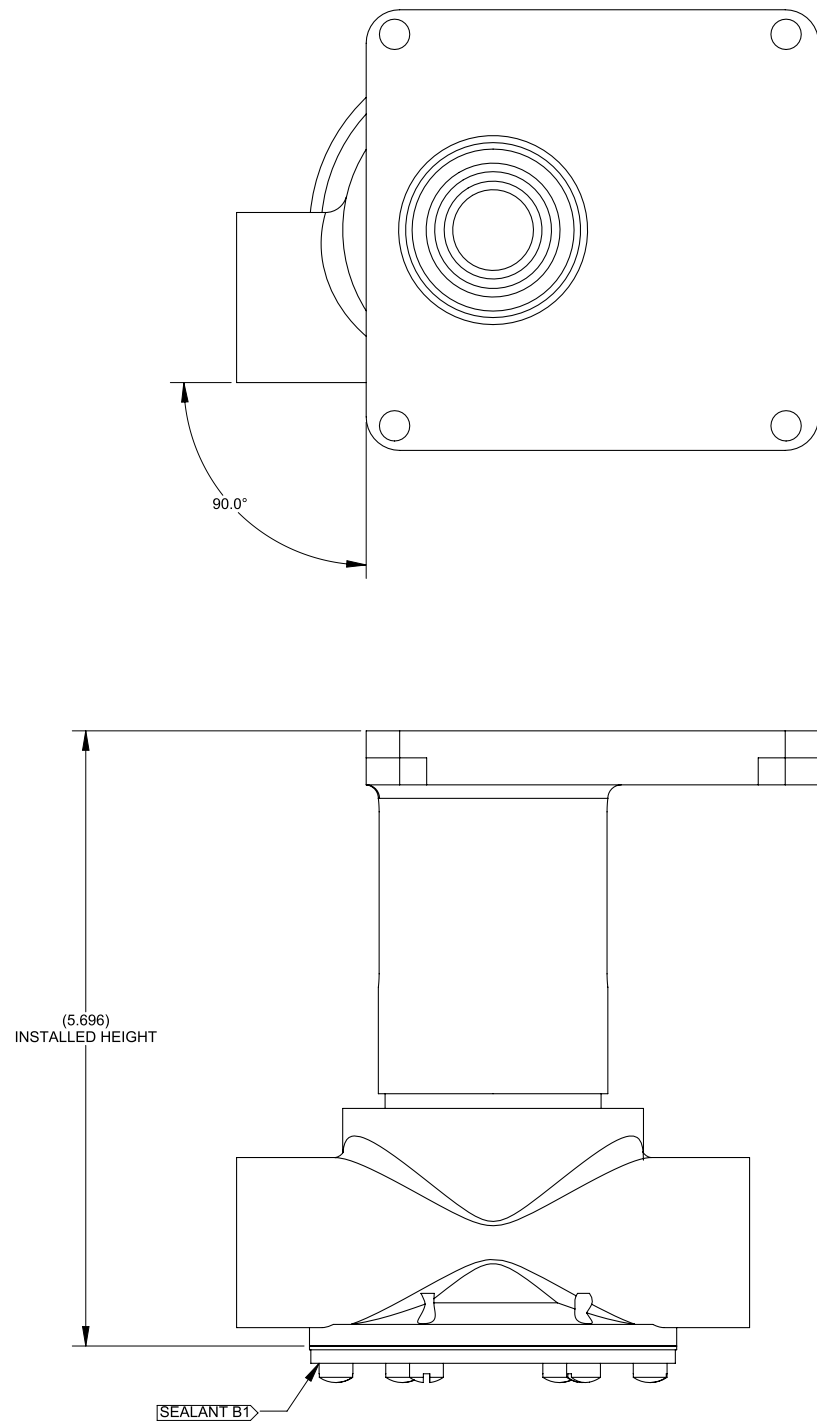

NOTICE

See Figure 8-1 for adhesive/sealant information.

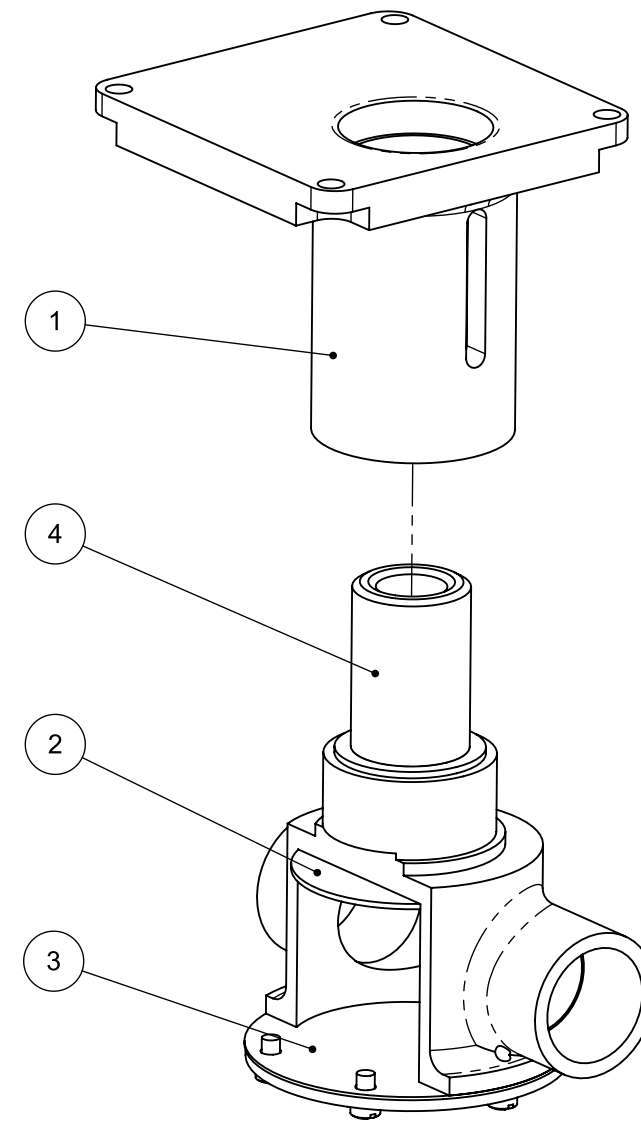

APO Pump Assembly Parts List

Item	Part Number	Description	Qty
1	000-092-010	Mount, APO Pump Head - Coated	1
2	000-105-696	Plate S/S APO Inner Wear	1
3	000-105-697	Plate S/S APO Outer Wear	1
4	000-111-168	Pump, Jabsco	1

Figure 8-34. APO Connection Kit
000-079-049 Rev C.

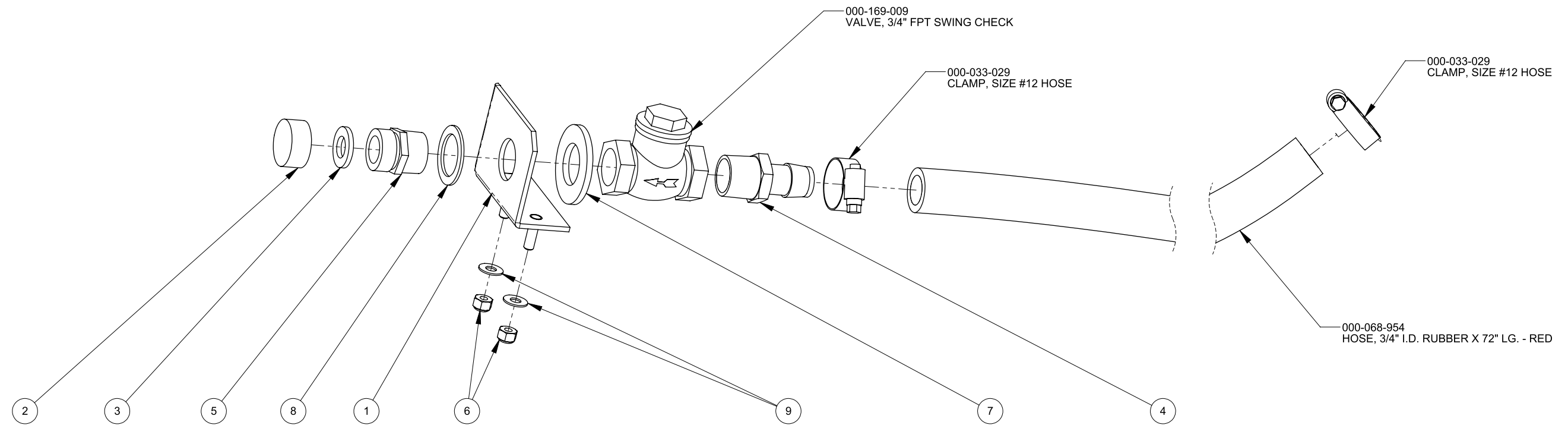

APO Connection Kit Assembly Parts List

Item	Part Number	Description	Qty
1	000-015-720	Bracket, APO Outlet Mounting - Coated	1
2	000-027-014	Cap, Garden Hose	1
3	000-057-055	Gasket, Garden Hose	1
4	000-052-338	Insert, #1212 (3/4" NPT X 3/4" Barb)	1
5	000-052-281	Nipple, 3/4" NPT X 3/4" Male Garden Hose	1
6	000-094-009	Nut, 1/4"-20UNC Nylock	2
7	000-174-050	Washer, 1" Flat	1
8	000-174-063	Washer, 1.5" O.D. X 1.073" I.D. X 0.075" Thk.	1
9	000-174-003	Washer, 1/4" Flat	2

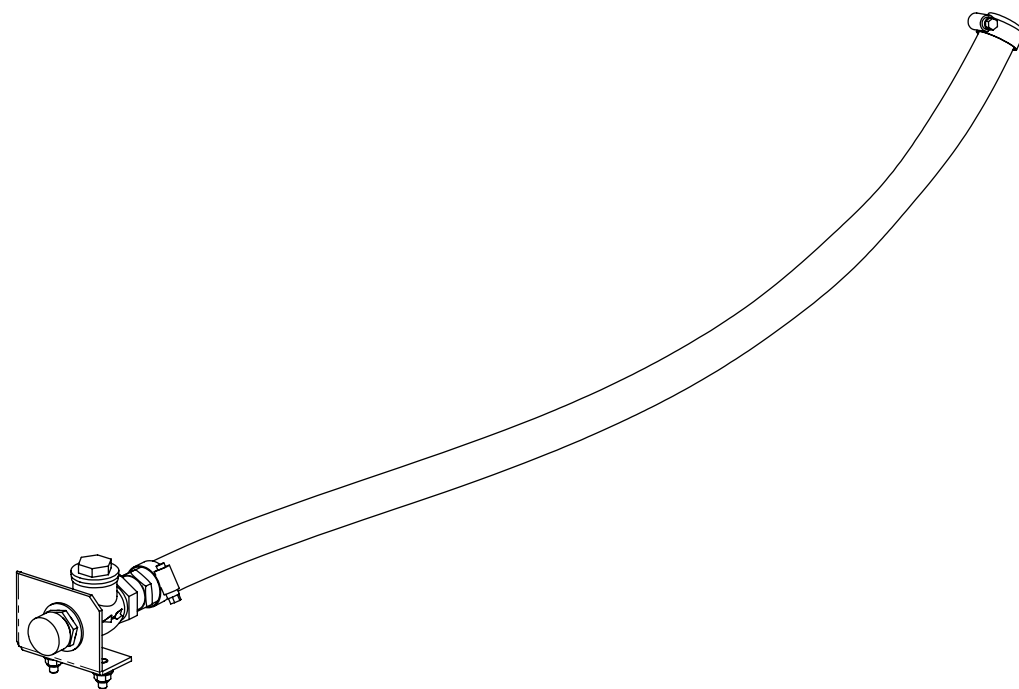

Hose Routings

Part No.	Description	Hose Routing	
		From	To
000-068-104	Hose, 2.5" I.D. X 2.5" Lg. Silicone	Blower	Silencer
000-068-104	Hose, 2.5" I.D. X 2.5" Lg. Silicone	Silencer	Lower Exhaust Elbow
000-068-203	Hose, 3/16" I.D. X 34" Lg.	Orifice Assembly	Water Box
000-068-517	Hose, 3/16" I.D. X 23" Lg.	Chemical Metering	Solution Out
000-068-517	Hose, 3/16" I.D. X 23" Lg.	Chemical Pump	Prime
000-068-518	Hose, 3/16" I.D. X 18.25" Lg.	Pump	Gauge
000-068-587	Hose, 3/8" I.D. Throb X 17.5" Lg.	By-Pass Valve	Heat Exchanger
000-068-627	Hose, 3/16" I.D. X 44" Lg.	Orifice Assembly	Rec Tank
000-068-724	Hose, 5/16" I.D. X 18" Lg.	Heat Exchanger	Solution Out
000-068-888	Hose, 3/16" I.D. X 24" Lg.	Heat Exchanger	Orifice Assembly
000-068-967	Hose, 1/2" I.D. Rubber X 20" Lg.	Water Box Drain	
000-068-968	Hose, 1/2" I.D. Rubber X 56" Lg	Pump	Water Box
000-068-969	Hose, 1/2" I.D. Rubber X 69" Lg.	Fresh Water In	Water Box
000-068-970	Hose, 3/4" I.D. Rubber X 50" Lg.	Pump	Water Box
000-068-971	Hose, 3/8" I.D. Clear w/ Braid X 60" Lg.	Chemical Pump	Flow
000-068-972	Hose, 3/8" I.D. Rubber X 76" Lg.	Chemical Prime	Recovery Tank
000-068-977	Hose, 5/32" I.D. Vacuum X 82" Lg.	Blower	Vacuum Gauge
000-068-978	Hose, 5/32" I.D. Vacuum X 52" Lg.	Blower	Lube Port
000-068-979	Hose, 1/4" I.D. Fuel Low Perm X 120" Lg.	Carburetor	Fuel Hook Up
000-068-980	Hose, 3/8" I.D. Clear w/ Braid X 28.5" Lg.	Chemical Jug	Flow

9 - How to Order Parts

This section describes how to obtain a proper diagnosis of any malfunctions, and how to order warranty replacement parts or repairs as outlined in the following areas:

- Warranty Parts Orders
- Parts Orders
- Emergencies

WARRANTY PARTS ORDERS

1. Call the local distributor where you purchased your equipment and ask for the Service Department.
2. Have the following information ready:
 - a. Equipment Model
 - b. Date of Purchase
 - c. Hours on the Unit
 - d. Unit Serial Number
 - e. Description of Malfunction
3. Once it has been determined which parts are needed to correct the problem with your truckmount, make arrangements with your distributor to either perform the repairs or ship the parts to you.

We shall always endeavor to be fair in our evaluation of your warranty claim, and shall provide you with a complete analysis of our findings.

HydraMaster warranty covers only defective materials and/or workmanship for the periods listed. **Diagnostic reimbursement is specifically excluded.**

PARTS ORDERS

Call your local distributor. In most instances, they either stock or have access to parts through a regional service center.

EMERGENCIES

If, for any reason, your distributor is unable to supply you with the necessary parts, they may call us and arrange for expedited shipping.

HydraMaster sells parts only through authorized distributors and service centers.

BOXER 318

10 - Warranty Information

This section lists causes of component failure that specifically void warranty coverage to avoid misunderstandings which might occur between truckmount owners and the manufacturer. Such causes as listed in this section shall constitute **abuse** or **neglect**.

The following topics are covered in this section

- Blower
- High Pressure Water Pump
- Recovery Tank
- Chemical System
- Control Panel
- Vacuum and Solution Hoses
- Cleaning Wand
- Water Heating System
- Hard Water Deposits
- Warranty Procedure

BLOWER

- Failure to lubricate the impellers daily with an oil based lubricant.
- Failure to lubricate the bearings as recommended in the blower manual.
- Failure to maintain the proper oil levels in the blower.
- Failure to use the correct oil grade and viscosity as recommended in the blower manual.
- Failure to properly maintain blower safeguard systems such as waste tank filter screen, vacuum safety relief valve and waste tank automatic shut-off system.
- Allowing foam to pass through the blower.

HIGH PRESSURE WATER PUMP

- Failure to maintain the proper oil level as recommended in the pump manual.
- Failure to change the oil in the pump at recommended intervals.
- Failure to protect the pump against freezing.
- Failure to maintain the pump protection shut-off system.
- Failure to use water softener in hard water areas.
- Use of improper chemicals.

BOXXER 318

RECOVERY TANK

- Failure to properly maintain the filtering devices in the tank.
- Failure to clean the tank as recommended by manufacturer.
- Failure to maintain the vacuum safety release in the tank.
- Use of improper chemicals.

CHEMICAL SYSTEM

- Use of improper chemicals.
- Failure to use water softener in hard water area.
- Operating truckmount without a proper chemical filter screen.
- Failure to protect against freezing.

CONTROL PANEL

- Failure to protect flowmeter and water pressure gauge against freezing.

VACUUM AND SOLUTION HOSES

- Failure to protect the hoses against freezing.
- Failure to protect the hoses against burns from the engine and blower exhaust.
- Damage to the hoses from being run over by vehicles.
- Kinking or cracking from failure to store or unroll the hoses correctly.
- Normal wear and tear from everyday use.

CLEANING WAND

- Failure to protect against freezing.
- Obvious physical abuse of the wand.

WATER HEATING SYSTEM

- Over-pressurization of the system (recommended maximum working pressure-1,000 psi).
- Failure to protect against freezing.

HARD WATER DEPOSITS

- Failure to use or maintain a water softening system or a properly installed magnetic-type descaler, whichever might be necessary, with truckmount's operating in designated "Hard Water Areas" (3.0 grains or more per gallon).

WARRANTY PROCEDURE

Warranty coverage is available to you through your local distributor.

If you have moved to a new area or have purchased a used machine and need information regarding your local distributor, call HydraMaster at (800) 426-1301 or email us at: techsupport@hydramaster.com.

When calling your distributor, be sure to have the machine's information; model and serial number, ready for the service representative.

FOR YOUR REFERENCE:

Model No. _____

Serial No. _____

Date of Purchase: _____

Purchased From (Distributor): _____

HYDRAMASTER® LIMITED WARRANTY

HydraMaster warrants to the original end user, each new machine, new accessories and genuine replacement parts against defects in material and workmanship under normal use and service. Our obligation under this warranty is limited to repair or replacement of the defective item at our factory or by an Authorized Service Center. Warranty coverage shall begin on the date of purchase by the original end user (as evidenced by your invoice from the factory or Authorized Dealer) or six (6) months from the date the machine was shipped from the factory whichever is earlier. The warranty registration card must be completed and returned within 30 days of purchase. The warranty coverage period is specified below.

GROUP	Parts ^{1,2}	Labor ²
Frame	3 Years	2 Years
Covers	3 Years	2 Years
Vacuum Recovery Tank (Structural only)	3 Years	2 Years
Vacuum Pump	See Note 3	2 Years
Chemical Systems	2 Years	2 Years
Hoses, Internal Machine	2 Years	2 Years
Hoses, External Machine	2 Years	2 Years
Valve, High pressure bypass	2 Years	2 Years
Water Heating System	2 Years	2 Years
Pump, High pressure water	See Note 3	2 Years
Belts	2 Years	2 Years
Fittings, internal machine	2 Years	2 Years
Filter Screens	2 Years	2 Years
Gauges	2 Years	2 Years
Electrical Components	2 Years	2 Years
Engine	See Note 3	2 Years
Accessories and Fresh Water Tanks	1 Year	1 Year
Replacement Parts ⁴	90 Days	NA
NOTES:		
1-Parts repaired or replaced are guaranteed for the remainder of the original machine warranty period.		
2-Coverage only applicable to products sold and used in the United States and Canada.		
3-As provided by the original Manufacturer.		
4-Applies to replacement parts only after machine warranty coverage has expired.		

This warranty shall not apply to repairs resulting from accidents or misuse, damage in transit, overloading the capacity of the machine, failure due to lack of proper maintenance or care as described in the operating and maintenance instructions. Freezing of any water or chemical related component will VOID all warranties on water or chemical related components, internal or external. Corrosion, deposits and/or build-up in the water, chemical, recovery or heating systems due to hardness in the water used or chemicals which result in deposits, will VOID all warranties on affected components. The use or application of any chemical including but not limited to acids or solvents, which results in damage to metal, rubber, plastic, or painted parts will VOID all warranties on those parts. Minor adjustments, such as tightening of screws or bolts not connected with the replacement of parts, are not covered. Replacement of expendable wear items including but not limited to paint, labels and other cosmetic parts are also not covered. Repairs or alterations by an organization other than the factory or an Authorized Service Center are not covered and will void any HydraMaster warranty as to the parts or systems repaired or altered by a non-authorized organization.

THERE ARE NO WARRANTIES THAT EXTEND BEYOND THE DESCRIPTION OF THE LIMITED WARRANTIES STATED WITHIN. NO OTHER WARRANTY EXPRESSED OR IMPLIED, INCLUDING BUT NOT LIMITED TO ANY IMPLIED WARRANTY OF MERCHANTABILITY OR FITNESS FOR A PARTICULAR PURPOSE, IS MADE EXCEPT AS EXPRESSLY STATED HEREIN. ANY STATUTORY IMPLIED WARRANTIES, INCLUDING ANY WARRANTY OF MERCHANTABILITY OR FITNESS FOR A PARTICULAR PURPOSE, THAT ARE IMPOSED BY LAW DESPITE THE EXPRESS LIMITATION OF WARRANTIES ABOVE, ARE EXPRESSLY LIMITED TO THE DURATION OF THE WRITTEN WARRANTY. BUYER UNDERSTANDS, ACKNOWLEDGES AND AGREES THAT THE REMEDIES PROVIDED UNDER THIS LIMITED WARRANTY ARE THE SOLE AND EXCLUSIVE REMEDIES AVAILABLE TO THE BUYER. HYDRAMASTER WILL NOT BE LIABLE FOR ANY OTHER OR ADDITIONAL DAMAGES, INCLUDING BUT NOT LIMITED TO INDIRECT, SPECIAL OR CONSEQUENTIAL DAMAGES ARISING OUT OF OR IN CONNECTION WITH THE FURNISHING, PERFORMANCE, USE OF OR INABILITY TO USE THE MACHINE. ANY EXTENSIONS OF OR MODIFICATIONS MADE TO THIS WARRANTY BY A DEALER/DISTRIBUTOR OF HYDRAMASTER ARE THE SOLE RESPONSIBILITY OF THE DEALER/DISTRIBUTOR.

HydraMaster will pay all freight and transportation charges within the United States, via normal ground shipping means, for replacement of parts covered under this warranty. All material must be properly authorized by HydraMaster prior to being returned. When returning, please provide an explanation of the problem and include the serial number of the machine as well as the name of the selling organization. All defective material must be returned to HydraMaster within 60 days of authorization. The Technical Service department of the authorized Dealer Service Center or the factory will investigate and then contact you.

Transportation of hazardous waste or contaminated equipment is subject to various laws and regulations. In returning machines, parts, or accessories under this limited warranty, the end user must certify in writing that the machines, parts or accessories being returned have not been used for handling, clean up, or disposal of hazardous waste or hazardous materials including but not limited to such things as asbestos, anthrax etc. or if the machines, parts or accessories being returned have been used for handling, clean up, or disposal of hazardous waste or hazardous materials, then the end user must have the machines, parts or accessories decontaminated by licensed and qualified decontamination professionals and provide written certification of this decontamination signed by the decontamination professionals. These machines, parts or accessories are to be returned only to the local HydraMaster Authorized Service Center for Warranty service along with decontamination certification.

HydraMaster reserves the right to change its warranty policy without notice.

HydraMaster is a Nilfisk-Advance, Inc. brand.

Warranty Information: 10-4

11 - Accessories and Chemical Solutions

HydraMaster's machine accessories are the most innovative collection available in the cleaning industry. For example, our RX-20® Rotary Extractors have changed the shape of carpet cleaning. In addition, our hoses, reels and tanks are of the finest quality construction.

Our carpet care and hard floor care chemical solutions have been specially prepared, not only to give you exceptional cleaning, but also to optimize your truckmount's operation and reliability. HydraMaster's chemical solutions will help maintain your machine's water pump and water heating systems at peak efficiency and also help ensure fewer breakdowns.

HydraMaster's full line of machine accessories and chemicals can enhance cleaning performance while reducing your labor costs, and include:

- Upholstery Tools
- Wands
- Vacuum Hoses
- Tanks
- Van Accessories
- Hose Reels
- Carpet Care Detergents
- Rinse Agents
- Pre-Sprays
- Hard Floor Care Detergents
- Defoamers and Descalers
- Deodorizers and Disinfectants
- Spotting Agents

For more information about our full line of accessories and chemical solutions, refer to the HydraMaster website at <http://www.hydramaster.com>.

To order genuine HydraMaster accessories and chemical solutions, call your nearest authorized HydraMaster Distributor.

BOXXER 318