

Intel® NUC 9 Extreme/Pro Kit Technical Product Specification

Revision 1.1

Regulatory Model: NUC9QN

March 2020

Intel® NUC 9 Extreme Kit NUC9i9QNX, NUC9i7QNX, NUC9i5QNX, Intel® NUC 9 Pro Kit NUC9VXQNX, or NUC9V7QNX may contain design defects or errors known as errata that may cause the product to deviate from published specifications. Current characterized errata, if any, are documented in this product specification

Revision History

Revision	Revision History	Date
1.0	First release	December 2019
1.1	Spec change	March 2020

Disclaimer

This product specification applies only to the standard Intel® NUC 9 Extreme/Pro Kits with BIOS identifier QXCFL579 or QNCFLX70.

INFORMATION IN THIS DOCUMENT IS PROVIDED IN CONNECTION WITH INTEL® PRODUCTS. NO LICENSE, EXPRESS OR IMPLIED, BY ESTOPPEL OR OTHERWISE, TO ANY INTELLECTUAL PROPERTY RIGHTS IS GRANTED BY THIS DOCUMENT. EXCEPT AS PROVIDED IN INTEL'S TERMS AND CONDITIONS OF SALE FOR SUCH PRODUCTS, INTEL ASSUMES NO LIABILITY WHATSOEVER, AND INTEL DISCLAIMS ANY EXPRESS OR IMPLIED WARRANTY, RELATING TO SALE AND/OR USE OF INTEL PRODUCTS INCLUDING LIABILITY OR WARRANTIES RELATING TO FITNESS FOR A PARTICULAR PURPOSE, MERCHANTABILITY, OR INFRINGEMENT OF ANY PATENT, COPYRIGHT OR OTHER INTELLECTUAL PROPERTY RIGHT. UNLESS OTHERWISE AGREED IN WRITING BY INTEL, THE INTEL PRODUCTS ARE NOT DESIGNED NOR INTENDED FOR ANY APPLICATION IN WHICH THE FAILURE OF THE INTEL PRODUCT COULD CREATE A SITUATION WHERE PERSONAL INJURY OR DEATH MAY OCCUR.

All Intel® NUC 9 Extreme/Pro Kits are evaluated as Information Technology Equipment (I.T.E.) for use in personal computers (PC) for installation in homes, offices, schools, computer rooms, and similar locations. The suitability of this product for other PC or embedded non-PC applications or other environments, such as medical, industrial, alarm systems, test equipment, etc. may not be supported without further evaluation by Intel.

Intel Corporation may have patents or pending patent applications, trademarks, copyrights, or other intellectual property rights that relate to the presented subject matter. The furnishing of documents and other materials and information does not provide any license, express or implied, by estoppel or otherwise, to any such patents, trademarks, copyrights, or other intellectual property rights.

Intel may make changes to specifications and product descriptions at any time, without notice.

Designers must not rely on the absence or characteristics of any features or instructions marked "reserved" or "undefined." Intel reserves these for future definition and shall have no responsibility whatsoever for conflicts or incompatibilities arising from future changes to them.

Intel processor numbers are not a measure of performance. Processor numbers differentiate features within each processor family, not across different processor families: Go to:

[Learn About Intel® Processor Numbers](#)

Intel® NUC 9 Extreme/Pro Kits may contain design defects or errors known as errata, which may cause the product to deviate from published specifications. Current characterized errata are available on request.

Contact your local Intel sales office or your distributor to obtain the latest specifications before placing your product order.

Intel, the Intel logo and Intel Core are trademarks of Intel Corporation in the U.S. and/or other countries.

* Other names and brands may be claimed as the property of others.

Copyright © 2020 Intel Corporation. All rights reserved.

Preface

This Product Specification specifies the layout, components, connectors, power and environmental features for the Intel® NUC 9 Extreme Kit NUC9i9QNX, NUC9i7QNX, NUC9i5QNX, Intel® NUC 9 Pro Kit NUC9VXQNX, and NUC9V7QNX.



NOTE

In this document, the use of “Intel® NUC 9 Extreme Kit” will refer to the NUC9i9QNX, NUC9i7QNX, or NUC9i5QNX versions. The use of “Intel® NUC 9 Pro Kit” will refer to the NUC9VXQNX or NUC9V7QNX versions. When possible further consolidation of the naming convention will be used “NUC 9 Extreme/Pro Kit” when referring to shared features or capabilities. The usage of “NUC 9 Extreme/Pro Compute Element” refers to the Intel® NUC Element product contained inside the NUC 9 Extreme/Pro Kit.

Intended Audience

This document is intended to provide technical information about Intel® NUC 9 Extreme Kit NUC9i9QNX, NUC9i7QNX, NUC9i5QNX, Intel® NUC 9 Pro Kit NUC9VXQNX, or NUC9V7QNX and its components to the vendors, system integrators, and other engineers and technicians who need this level of information. It is specifically *not* intended for general audiences.

What This Document Contains

Chapter	Description
1	A description of the NUC9i9QNX, NUC9i7QNX, NUC9i5QNX, NUC9VXQNX, or NUC9V7QNX features
2	A technical description of the NUC9i9QNX, NUC9i7QNX, NUC9i5QNX, NUC9VXQNX, or NUC9V7QNX subsystems
3	The features supported by the BIOS Setup program
4	Characterized errata
5	Regulatory compliance information

Typographical Conventions

This section contains information about the conventions used in this specification. Not all of these symbols and abbreviations appear in all specifications of this type.

Notes, Cautions, and Warnings



NOTE

Notes call attention to important information.



CAUTION

Cautions are included to help you avoid damaging hardware or losing data

Other Common Notation

#	Used after a signal name to identify an active-low signal (such as USBP0#)
GB	Gigabyte (1,073,741,824 bytes)
GB/s	Gigabytes per second
Gb/s	Gigabits per second
KB	Kilobyte (1024 bytes)
Kb	Kilobit (1024 bits)
kb/s	1000 bits per second
MB	Megabyte (1,048,576 bytes)
MB/s	Megabytes per second
Mb	Megabit (1,048,576 bits)
Mb/s	Megabits per second
TDP	Thermal Design Power
Xxh	An address or data value ending with a lowercase h indicates a hexadecimal value.
x.x V	Volts. Voltages are DC unless otherwise specified.
*	This symbol is used to indicate third-party brands and names that are the property of their respective owners.

Intel® NUC 9 Extreme/Pro Kit Identification Information

Intel® NUC 9 Extreme/Pro Kit Identification Information

AA Revision	Product Code	BIOS Revision	Notes
K49243-xxx	NUC9i9QNX	QXCFL579.xxxx	1,2
K49245-xxx	NUC9i7QNX	QXCFL579.xxxx	1,3
K49427-xxx	NUC9i5QNX	QXCFL579.xxxx	1,4
K47179-xxx	NUC9VXQNX	QNCFLX70.xxxx	1,5
K49010-xxx	NUC9VXQNX	QNCFLX70.xxxx	1,6
K47180-xxx	NUC9V7QNX	QNCFLX70.xxxx	1,7
K48935-xxx	NUC9V7QNX	QNCFLX70.xxxx	1,8

Notes:

- The AA number is found on the back of the NUC 9 Extreme/Pro Compute Element.
- The Intel® Core™ i9-9980HK processor is used on this AA revision consisting of the following component:

Device	Stepping	Spec Code
Intel® Core™ i9-9980HK	R0	SRFDO

- The Intel® Core™ i7-9750H processor is used on this AA revision consisting of the following component:

Device	Stepping	Spec Code
Intel® Core™ i7-9750H	R0	SRF6U

- The Intel® Core™ i5-9300H processor is used on this AA revision consisting of the following component:

Device	Stepping	Spec Code
Intel® Core™ i5-9300H	R0	SRF6X

- The Intel® Xeon™ E-2286M processor with TPM is used on this AA revision consisting of the following component:

- The Intel® Xeon™ E-2286M processor with TCM is used on this AA revision consisting of the following component:

Device	Stepping	Spec Code
Intel® Xeon™ E-2286M	R0	SRFCZ

- The Intel® Core™ i7-9850H processor with TPM is used on this AA revision consisting of the following component:

- The Intel® Core™ i7-9850H processor with TCM is used on this AA revision consisting of the following component:

Device	Stepping	Spec Code
Intel® Core™ i7-9850H	R0	SRFCN

Production Identification Information

Intel® NUC Products NUC9i9QN, NUC9i7QN, NUC9i5QN, NUC9VXQN, NUC9V7QN Identification Information

Kit Product Name	Intel® NUC Compute Element
NUC9i9QNX	NUC9i9QNB
NUC9i7QNX	NUC9i7QNB
NUC9i5QNX	NUC9i5QNB
NUC9VXQNX	NUC9VXQNB
NUC9V7QNX	NUC9V7QNB

Specification Changes or Clarifications

The table below indicates the Specification Changes or Specification Clarifications that apply to the Intel® NUC 9 Extreme Kit NUC9i9QNX, NUC9i7QNX, NUC9i5QNX, Intel® NUC 9 Pro Kit NUC9VXQNX, or NUC9V7QNX.

Specification Changes or Clarifications

Date	Type of Change	Description of Changes or Clarifications
March 2020	Spec change	Intel® Thunderbolt 3 section added, USB port capabilities added

Errata

Current characterized errata, if any, will be documented in Section 0 of this Technical Product Specification.

Contents

Revision History	iii
Disclaimer	iii
Preface	iv
Intended Audience.....	iv
What This Document Contains	iv
Typographical Conventions	v
Intel® NUC 9 Extreme/Pro Kit Identification Information.....	vii
Specification Changes or Clarifications.....	viii
Errata.....	viii
Contents	ix
1 Product Description	1
1.1 Overview	1
1.2 Version Summary.....	1
1.3 Feature Summary.....	2
2 Technical Reference	5
2.1 Block Diagram.....	5
2.2 Processor.....	6
2.3 Platform Controller Hub (PCH).....	6
2.3.1 Direct Media Interface (DMI).....	6
2.4 System Memory	6
2.4.1 Addressable Memory.....	8
2.5 Processor Graphics Subsystem.....	8
2.5.1 Integrated Graphics	8
2.6 USB.....	9
2.7 Thunderbolt 3.....	10
2.8 Storage Options.....	10
2.8.1 AHCI Mode.....	10
2.8.2 NVMe.....	10
2.8.3 Intel® Rapid Storage Technology / SATA RAID	11
2.9 Real-Time Clock Subsystem.....	12
2.10 LAN 12	
2.10.1 Intel® Gigabit Ethernet Controller I219-LM	12
2.10.2 Intel® Gigabit Ethernet Controller I210-AT.....	13
2.10.3 LAN Software.....	13
2.11 Intel® Security and Manageability Technologies.....	14
2.11.1 Intel® vPro™ Technology	14
2.12 Power Management	17

2.12.1	ACPI.....	17
2.12.2	Hardware Support.....	20
2.13	Audio Subsystem Software.....	21
2.13.1	HDMI Audio Subsystem Software.....	21
2.13.2	Stereo/TOSLINK HD Audio Subsystem Software	21
2.14	Connectors, Headers, and Expansion.....	22
2.14.1	Front Panel Connectors.....	22
2.14.2	Back Panel Connectors	23
2.14.3	Baseboard Connectors.....	24
2.14.4	Interior Chassis Connectors	25
2.15	NUC 9 Extreme/Pro Element Headers and Connectors.....	26
2.15.1	Signal Tables for Headers and Connectors	27
2.16	Wireless Network Module.....	31
2.17	Antenna Connectors.....	32
2.18	Internal Power Supply.....	32
2.19	Add-in Card Limitations.....	33
2.20	NUC 9 Extreme/Pro Kit Dimensions.....	34
2.21	Thermal Considerations.....	37
2.22	Reliability	38
2.23	Environmental	39
3	Overview of BIOS Features.....	40
3.1	Introduction.....	40
3.2	System Management BIOS (SMBIOS).....	40
3.3	Legacy USB Support	40
3.4	BIOS Updates.....	41
3.4.1	Language Support.....	41
3.4.2	BIOS Recovery.....	42
3.5	Boot Options.....	43
3.5.1	Network Boot.....	43
3.5.2	Booting Without Attached Devices	43
3.5.3	Boot Device Selection During POST	43
3.5.4	Power Button Menu.....	43
3.6	Hard Disk Drive Password Security Feature.....	45
3.7	BIOS Security Features	46
3.8	Error Messages.....	47
3.8.1	BIOS Error Messages.....	47
4	Characterized Errata.....	48
5	Regulatory Compliance and Battery Disposal Information	49
5.1	Regulatory Compliance.....	49
5.1.1	Safety Standards.....	49
5.1.2	European Union Declaration of Conformity Statement	49
5.1.3	EMC Regulations	51

5.1.4	e-Standby and ErP Compliance.....	52
5.1.5	Regulatory Compliance Marks (Board Level).....	53
5.2	Battery Disposal Information	54

Figures

Figure 1.	Block Diagram.....	5
Figure 2.	SODIMM Location on NUC 9 Extreme/Pro Element.....	7
Figure 3.	Location of NUC 9 Extreme/Pro Compute Element M.2 Slots and Battery	11
Figure 4.	NUC 9 Extreme/Pro Kit LAN Controller Layout	13
Figure 5.	4-Pin 3.5 mm (1/8 inch) Audio Jack Pin Out	21
Figure 6.	Front Panel Connectors.....	23
Figure 7.	Back Panel Connectors.....	24
Figure 8.	BBWC1B Baseboard Connectors.....	25
Figure 9.	NUC 9 Extreme/Pro Chassis Interior Front Panel Headers and Connectors.....	26
Figure 10.	NUC 9 Extreme/Pro Compute Element Headers and Connectors.....	27
Figure 11.	Location of the Antenna Connectors	32
Figure 12.	Front Side	34
Figure 13.	Back Side.....	35
Figure 14.	Top Side	36
Figure 15.	Side Panel.....	37

Tables

Table 1.	Version Summary	1
Table 2.	Feature Summary	2
Table 3.	Effects of Pressing the Power Switch.....	18
Table 4.	Power States and Targeted System Power	19
Table 5.	Wake-up Devices and Events.....	20
Table 6.	Intel BBWC1B Baseboard configuration.....	24
Table 7.	Components shown in Figure 10.....	27
Table 8.	Power supply rating table.....	32
Table 9.	PCI Express Add-in Cards Limitations	33
Table 10.	Environmental Specifications.....	39
Table 11.	Acceptable Drives/Media Types for BIOS Recovery	42
Table 12.	Boot Device Menu Options.....	43
Table 13.	Master Key and User Hard Drive Password Functions.....	45
Table 14.	Supervisor and User Password Functions.....	46
Table 15.	BIOS Error Messages.....	47
Table 16.	Safety Standards.....	49
Table 34.	EMC Regulations	51
Table 35.	Regulatory Compliance Marks	53

1 Product Description

1.1 Overview

The Intel® NUC 9 Extreme Kit and the Intel® NUC 9 Pro Kit are small form factor PC barebones kits. The NUC 9 Extreme/Pro Kit consists of the processor, chipset, memory slots, wireless, Bluetooth*, M.2 storage slots, integrated heat sink and fan, and depending on the model may include discrete TPM. See Table 1 for a summary.

The Intel® NUC 9 Extreme Kit and the Intel® NUC 9 Pro Kit can operate as a standalone card but may require a compatible baseboard in order to take advantage of additional PCI Express functionality.

For information on compatible devices for use with the Intel® NUC 9 Extreme Kit and the Intel® NUC 9 Pro Kit see <http://www.intel.com/NUCElements>.

1.2 Version Summary

There are three different versions of this model of Intel® NUC 9 Extreme Kit and two different versions of this model of Intel® NUC 9 Pro Kit available which are summarized in Table 1. Unless otherwise noted in this document, not all features are available on all versions.

Table 1. Version Summary

Version	Intel® vPro™	Discrete TPM	Memory	XMP	ECC	Processor
NUC9i9QNX (Extreme)	No	No	Up to 64GB	Yes	No	Intel® Core™ i9-9980HK
NUC9i7QNX (Extreme)	No	No	Up to 64GB	Yes	No	Intel® Core™ i7-9750H
NUC9i5QNX (Extreme)	No	No	Up to 64GB	No	No	Intel® Core™ i5-9300H
NUC9VXQNX (Pro)	Yes	Yes	Up to 64GB	No	Yes	The Intel® Xeon™ E-2286M
NUC9V7QNX (Pro)	Yes	Yes	Up to 64GB	No	No	The Intel® Core™ i7-9850H



NOTE

Intel® NUC 9 Extreme Kits and Intel® NUC 9 Pro Kits listed in Table 1 have been certified for use as a component in Information Technology Equipment in certain countries. The system integrator is responsible for testing and acquiring any additional country-specific regulatory approvals, including all system-wide certifications.



NOTE

For information on the Intel NUC 9 Extreme Compute Element or Intel NUC 9 Pro Compute Element the NUC9QN Element Prod Spec is available at www.intel.com/NUCSupport

1.3 Feature Summary

Table 2 summarizes the major features of the Intel® NUC 9 Extreme and Intel® NUC 9 Pro Kits.

Table 2. Feature Summary

Form Factor	238mm x 216mm x96mm
Processor	<ul style="list-style-type: none"> • Soldered-down Intel® processor <ul style="list-style-type: none"> ○ Integrated graphics ○ Integrated memory controller • The following processors are supported as intalled in the corresponding NUC 9 Extreme/Pro Compute Element <ul style="list-style-type: none"> ○ Intel® Core™ i9-9980HK ○ Intel® Core™ i7-9750H ○ Intel® Core™ i5-9300H ○ Intel® Xeon™ E-2286M ○ Intel® Core™ i7-9850H
PCH	Intel® CM246 Platform Controller Hub
Memory	<ul style="list-style-type: none"> • Two 260-pin 1.2 V DDR4 SDRAM Small Outline Dual Inline Memory Module (SO-DIMM) sockets • Support for DDR4 2666 MHz SO-DIMMs • Support for 8 Gb and 16 Gb memory technology† • Support for up to 64 GB of system memory with two SO-DIMMs using 16 Gb memory technology† • Support for non-ECC memory available on all SKUs • Support for ECC memory only available on (NUC9VXQNX) • Support for 1.2 V and 1.35 V low voltage JEDEC memory only • Support for Intel® XMP only available on (NUC9i9QNX and NUC9i7QNX) • Note: 2 Gb memory technology (SDRAM Density) is not compatible
Graphics	<ul style="list-style-type: none"> • Integrated graphics support for processors with Intel® Graphics Technology: • One High Definition Multimedia Interface* (HDMI*) v2.0a back panel connector • Two DisplayPort signals via USB Type C back panel connectors
Audio	<ul style="list-style-type: none"> • Intel® High Definition (Intel® HD) Audio via the HDMI and Type C interfaces through the processor • Realtek HD Audio via a stereo 3.5mm combination speaker/TOSLINK jack on the back panel • Realtek HD Audio via a stereo 3.5mm combination microphone/headphone on the front panel
Storage	<ul style="list-style-type: none"> • On the NUC 9 Extreme/Pro Compute Element - Two SATA 6.0 Gb/s or Gen3 PCIe X4 AHCI, NVMe ports are reserved for M.2 storage modules supporting M.2 2242, M.2 2280 and M.2 22110 (key type M) modules Both slots support up to 2280, while outermost slot supports up to 22110 Note: Supports key type M (PCI Express* x1/x2/x4 and SATA) • On the baseboard - One Gen3 PCIe X4 NVMe only port for M.2 modules supporting M.2 2242, M.2 2280, or M.2 22110.
Peripheral Interfaces	<ul style="list-style-type: none"> • USB 3.1 (Gen 2/10 Gbps) Type C ports: <ul style="list-style-type: none"> • Two ports are implemented via the back panel Type C connectors • USB 3.1 (Gen 2/10 Gbps) Type A ports: <ul style="list-style-type: none"> • Four port are implemented via the back panel connectors (blue) • Two ports via the desktop front panel (black) • One port via the internal USB 3.1 front panel • USB 2.0 ports: <ul style="list-style-type: none"> • Two ports via two single-port internal 1x4 1.25 mm pitch headers (black in white keepout space) • SD Card Reader: <ul style="list-style-type: none"> • One UHS-II capable SDXC Card Reader on Front Panel

Chassis Expansion Capabilities	<ul style="list-style-type: none"> • One PCIe 3.0 x16 slot* with support for a dual slot GPU up to ~8" (202mm) maximum length • One PCIe 3.0 x4 slot* with support for full height cards up to ~8" (202mm) • One M.2 3.0 x4 (NVMe only) • Note: PCIe 3.0 x16 slot will run in x8 mode if either M.2 x4 slot or PCIe x4 slot are used from internal chassis baseboard, physical space for the dual slot GPU will encroach into the PCIe 3.0 x4 slot keep-out area
NUC Element Expansion Capabilities	<ul style="list-style-type: none"> • Two M.2 connectors supporting AHCI and NVME protocols • Two Thunderbolt™ 3 via back panel Type C connectors
BIOS	<ul style="list-style-type: none"> • Intel® BIOS resident in the Serial Peripheral Interface (SPI) Flash device • Support for Advanced Configuration and Power Interface (ACPI), Plug and Play, and System Management BIOS (SMBIOS)
Wireless LAN	<ul style="list-style-type: none"> • Intel® Wi-Fi 6 AX200, 802.11ax, Dual Band, 2x2 Wi-Fi + Bluetooth 5 • Maximum Transfer speed up to 2.4 Gbps • Next Generation Form Factor (NGFF) 12x16 soldered-down package • Supports OFDMA, 1024QAM, Target Wake Time (TWT) and spatial reuse
LAN	<ul style="list-style-type: none"> • Gigabit (10/100/1000 Mb/s) LAN subsystem using the Intel® Gigabit Ethernet Controller I219-LM • Gigabit (10/100/1000 Mb/s) LAN subsystem using the Intel® Gigabit Ethernet Controller I210-at
Hardware Monitor Subsystem	<p>Hardware monitoring subsystem, based on an embedded controller, including:</p> <ul style="list-style-type: none"> • Voltage sense to detect out of range power supply voltages • Thermal sense to detect out of range thermal values • One processor fan header • One chassis fan header • Fan sense input used to monitor fan activity • Fan speed control
Devices Supported via PCIe Bifurcation	<ul style="list-style-type: none"> • PCI Express 3.0 x16 <ul style="list-style-type: none"> • Bifurcation supported to a maximum of three PCI Express devices (x8 + 2x4)
Advanced Technologies	<ul style="list-style-type: none"> • Intel® vPro™ Technology (NUC9VXQNX and NUC9V7QNX only) • Intel® Virtualization Technology (VT-x) • Intel® Virtualization for Directed I/O (VT-d) • Intel® VT-x with Extended Page Tables (EPT) • Intel® Speed Shift Technology • Intel® Turbo Boost Technology • Intel® Hyper-Threading Technology • Enhanced Intel® SpeedStep® Technology • Intel® Identity Protection Technology (Intel® IPT) • Intel® Platform Trust Technology (Intel® PTT)
Security and Reliability	<ul style="list-style-type: none"> • Intel® Active Management Technology 12.0 (Intel® AMT) – (NUC9VXQNX and NUC9V7QNX only) • Intel® Memory Protection Extensions (Intel® MPX) • Intel® Software Guard Extensions (Intel® SGX) • Intel® AES New Instructions • Execute Disable Bit • Discrete Trusted Platform Module 2.0 (TPM) – (NUC9VXQNX and NUC9V7QNX only)
Operating Systems Support (64-bit only)	<ul style="list-style-type: none"> • Windows* 10 Home • Windows 10 Pro • Windows 10 Enterprise • Windows 10 Education • Windows 10 IoT Enterprise • Some Linux* operating systems may be supported. Check with the specific Linux distribution to make sure that support is available for this platform.

To find information about...

Intel® NUC Elements

Intel® NUC Element Support

Intel® NUC Element Warranty Information

Available configurations for Intel® NUC 9 Pro Kit

Available configurations for Intel® NUC 9 Extreme Kit

Intel Processors

Intel Chipsets

Intel Graphics

Intel Wireless

Intel Technologies

Intel® NUC Support

Visit this World Wide Web site:

<http://www.intel.com/ComputeElements>

<http://www.intel.com/ComputeElementsSupport>

<http://www.intel.com/NUCWarranty>

<http://ark.intel.com>

<http://ark.intel.com>

<http://www.intel.com/processors>

<http://www.intel.com/chipsets>

<http://www.intel.com/graphics>

<http://www.intel.com/wireless>

<http://www.intel.com/technology>

<http://www.intel.com/NUCSupport>

2 Technical Reference

2.1 Block Diagram

Figure 1 is a block diagram of the major functional areas of the Intel® NUC 9 Extreme Kit and the Intel® NUC 9 Pro Kit.

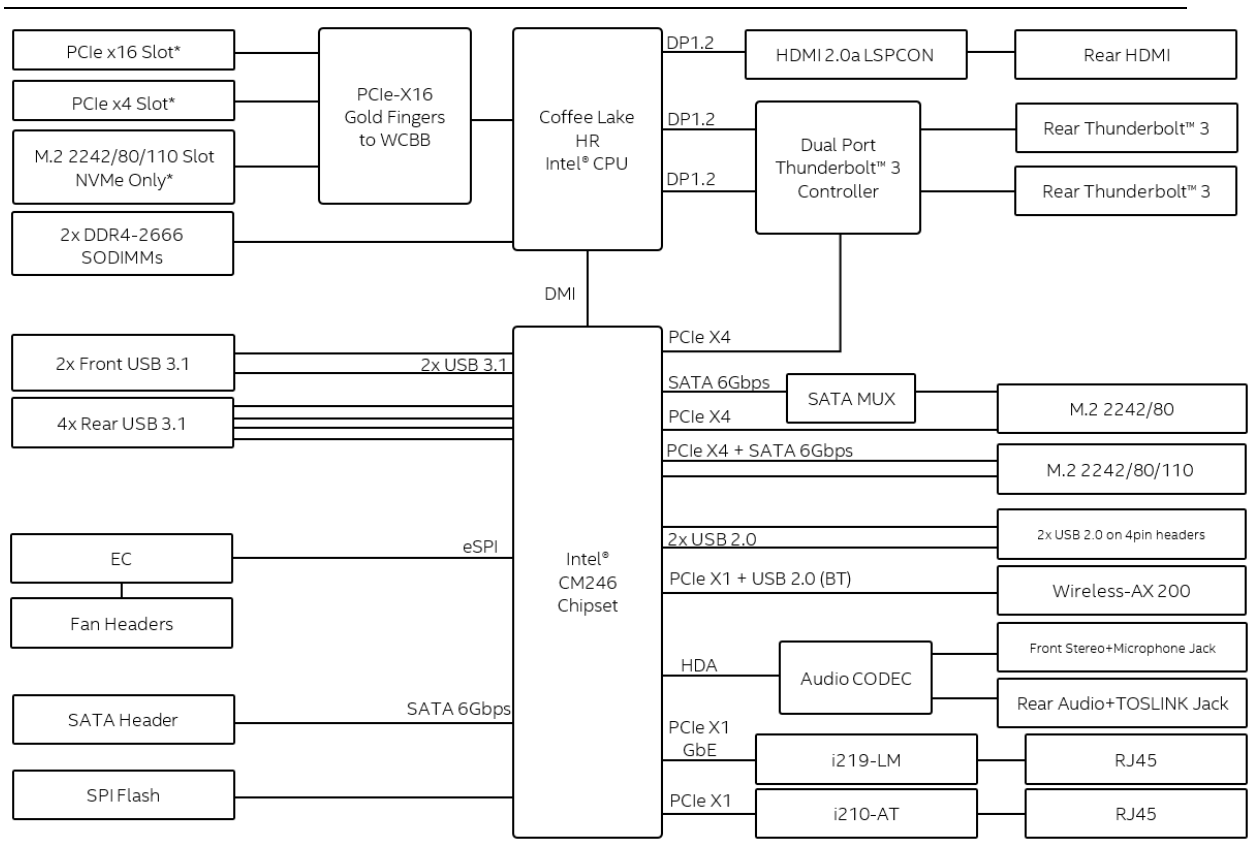

Figure 1. Block Diagram



NOTE

While the PCIe x16 slot, PCIe x4 slot, and M.2 2242/80/110 Slot NVMe Only devices are shown connected to the BBWC1B they will share bandwidth when more than one device is connected due to PCIe Bifurcation detailed in Table 6.

2.2 Processor

Intel NUC 9 Extreme Kits feature the Intel NUC 9 Extreme Compute Element pre-installed into the kit. All Intel NUC 9 Extreme Kits feature a 9th Gen Intel® Core™ processor with 45W TDP.

The NUC9i9QNX features the 9th Gen Intel Core i9-9980HK eight-core processor.

The NUC9i7QNX features the 9th Gen Intel Core i7-9750H six-core processor.

The NUC9i5QNX features the 9th Gen Intel Core i5-9300H quad-core processor.

- Intel® UHD Graphics 630
- Integrated memory controller

The Intel NUC 9 Pro Kit NUC9VXQNX features an Intel® Xeon™ E-2286M processor with a 45W TDP.

- Intel® UHD Graphics P630
- Integrated memory controller

The Intel NUC 9 Pro Kit NUC9V7QNX features an Intel® Core™ i7-9850H processor with a 45W TDP.

- Intel® UHD Graphics 630
- Integrated memory controller

2.3 Platform Controller Hub (PCH)

The Intel NUC 9 Extreme/Pro Kits feature a soldered-down Mobile Intel® CM246 Platform Controller Hub with Direct Media Interface (DMI) interconnect providing interfaces to the processor and the USB, SATA, LAN, PCI Express interfaces. The CM246 is a centralized controller for the kit's I/O paths.

2.3.1 Direct Media Interface (DMI)

Direct Media Interface (DMI) is the chip-to-chip connection between the processor and PCH. This high-speed interface integrates advanced priority-based servicing allowing for concurrent traffic and true isochronous transfer capabilities.

2.4 System Memory

The Intel NUC Extreme/Pro Kit has two 260-pin SO-DIMM sockets and supports the following memory features:

- 1.2 V DDR4 SDRAM SO-DIMMs with gold plated contacts
- Two independent memory channels with interleaved mode support
- Unbuffered, single-sided or double-sided SO-DIMMs
- 64 GB maximum total system memory (with 16 Gb memory technology)
- Minimum recommended total system memory: 4096 MB
- Non-ECC SO-DIMMs (All NUC 9 Extreme/Pro Kits)
- ECC SO-DIMMs (NUC9VXQNX)

- Serial Presence Detect
- DDR4 2133/2400/2666 MHz SDRAM SO-DIMMs
- Intel® XMP support (NUC9i9QNX and NUC9i7QNX)

Supports 4 Gb, 8 Gb, and 16 Gb memory technology (SDRAM Density)



NOTE

To be fully compliant with all applicable DDR SDRAM memory specifications, the board should be populated with SO-DIMMs that support the Serial Presence Detect (SPD) data structure. This allows the BIOS to read the SPD data and program the chipset to accurately configure memory settings for optimum performance. If non-SPD memory is installed, the BIOS will attempt to correctly configure the memory settings, but performance and reliability may be impacted or the SO-DIMMs may not function under the determined frequency.



NOTE

Intel NUC Extreme/Pro Kits support only 4 Gb, 8 Gb, and 16 Gb memory technologies (also referred to as “SDRAM density”).

For information about...

Tested Memory

Refer to:

<http://www.intel.com/NUCSupport>

The SODIMM memory slots on the NUC 9 Extreme/Pro Kits is located underneath the NUC 9 Extreme/Pro Compute Element shroud door. See Figure 2.

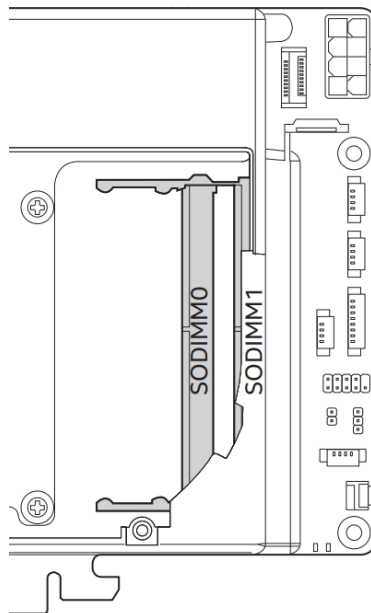

Figure 2. SODIMM Location on NUC 9 Extreme/Pro Element

2.4.1 Addressable Memory

The system has been validated with up to 64 GB of addressable system memory. Typically, the address space that is allocated for PCI Express configuration space, BIOS (SPI Flash device), and chipset overhead resides above the top of DRAM (total system memory). On a system that has 16 GB of system memory installed, it is not possible to use all of the installed memory due to system address space being allocated for other system critical functions. These functions include the following:

- BIOS/SPI Flash device (32 MB)
- Local APIC (19 MB)
- Direct Media Interface (40 MB)
- PCI Express configuration space (256 MB)
- PCH base address registers PCI Express ports (up to 256 MB)
- Memory-mapped I/O that is dynamically allocated for M.2 add-in cards (256 MB)
- Integrated graphics shared memory (up to 1.5 GB; 64 MB by default)

2.5 Processor Graphics Subsystem

The NUC Extreme/Pro Kit supports graphics through either the Intel® UHD Graphics 630 or Intel® UHD Graphics P630.

For information about...

Intel Graphics Technologies

Refer to:

<http://www.intel.com/graphics>

2.5.1 Integrated Graphics

The NUC Extreme/Pro Kit supports integrated graphics via the processor.

2.5.1.1 High Definition Multimedia Interface* (HDMI*)

The HDMI port is HDMI 2.0a specification compliant and support standard, enhanced, or high definition video, plus multi-channel digital audio on a single cable. The port is compatible with all ATSC and DVB HDTV standards and supports thirty-two full range channels of lossless audio formats. The system can support a display at the maximum supported resolution of 4096 x 2160 @ 60 Hz, 24bpp.

For information about

HDMI technology

Refer to

<http://www.hdmi.org>

2.5.1.1.1 Integrated Audio Provided by the HDMI Interfaces

The following audio technologies are supported by the HDMI 2.0a interface:

- 192kHz/16-bit or 176.4 kHz/24-bit, 32 Channel

2.5.1.1.2 High-bandwidth Digital Content Protection (HDCP)

The HDMI Port supports HDCP 2.2. HDCP is the technology for protecting high definition content against unauthorized copy or interception between a source (computer, digital set top boxes, etc.) and the sink (panels, monitor, and TVs). The PCH supports HDCP 2.2 for content protection over wired displays.

2.5.1.2 DisplayPort* via Type C

DisplayPort is a digital communication interface that utilizes differential signaling to achieve a high bandwidth bus interface designed to support connections between PCs and monitors, projectors, and TV displays. DisplayPort is suitable for display connections between consumer electronics devices such as high definition optical disc players, set top boxes, and TV displays. The Type C DisplayPort connectors are compliant with the DisplayPort 1.2 specification and thus have a maximum supported resolution of 4096 x 2160 @ 60Hz 24bpp.

DisplayPort output supports Multi-Stream Transport (MST) which allows for multiple independent video streams (daisy-chain connection with multiple monitors) over a single DisplayPort. This will require the use of displays that support DisplayPort 1.2 specification and allow for this feature.

For information about

DisplayPort technology

Refer to

<http://www.displayport.org>

2.6 USB

The NUC 9 Extreme/Pro Kit supports eleven USB ports. All eleven ports are high-speed, full-speed, and low-speed capable. The USB 3.1 Gen 2 ports are capable of up to 10gb/s per port. The port arrangement is as follows:

- USB 3.1 Gen 2 ports:
 - Two ports are implemented with external front panel connectors (black)
 - Four ports are implemented with external back panel connectors (blue)
 - Two ports are implemented with as USB Type-C back panel connectors (black)
 - One port is implemented as an internal USB Type-A port in the front of the chassis.
- USB 2.0 ports:
 - Two ports via two single-port internal 1x4 1.25 mm pitch headers on NUC 9 Extreme/Pro Compute Element (black in white outline space)

**NOTE**

Computer systems that have an unshielded cable attached to a USB port may not meet FCC Class B requirements, even if no device is attached to the cable. Use a shielded cable that meets the requirements for full-speed devices.

2.7 Thunderbolt 3

The NUC 9 Extreme/Pro Kits support Thunderbolt™ 3 with up to 40 Gbps of data throughput, two 4k (60Hz) monitor outputs, USB3.1 (Gen 2) connection and charging capabilities up to 5V at 3A via the back panel USB Type C connectors. Item D in Figure 7 shows the location of the rear panel USB Type C ports.



NOTE

The two Thunderbolt™ 3 connectors share maximum available bandwidth between the two ports where a single device can utilize the full allocation until those resources are dynamically reassigned and or shared.

For information about	Refer to
Compatible Thunderbolt™ 3 devices	https://www.intel.com/content/www/us/en/support/articles/000027966.html
Thunderbolt™ 3 information	http://www.intel.com/Thunderbolt

2.8 Storage Options

The NUC 9 Extreme/Pro Kit provides the following Storage interfaces:

- Two internal M.2 NVMe/SATA slots supporting one M.2 2242/80 and one M.2 2242/80/110 (key type M) modules on NUC 9 Extreme/Pro Compute Element.
- One internal M.2 NVMe only slot located on the baseboard underneath the NUC 9 Extreme/Pro Element. Refer to Section 2.14.3 for the location of the baseboard M.2 slot.
- One SATA 6.0 Gb/s powered port (on NUC 9 Extreme/Pro Compute Element not usable on the NUC 9 Extreme/Pro Kit)

The PCH provides independent SATA ports with a theoretical maximum transfer rate of 6 Gb/s. A point-to-point interface is used for host to device connections.

2.8.1 AHCI Mode

The NUC 9 Extreme/Pro Kit supports AHCI storage mode.



NOTE

In order to use AHCI mode, AHCI must be enabled in the BIOS. Microsoft Windows* 10 includes the necessary AHCI drivers without the need to install separate AHCI drivers during the operating system installation process; however, it is always good practice to update the AHCI drivers to the latest available by Intel.*

2.8.2 NVMe

The board supports M.2 NVMe Express* (NVMe) drives. NVMe is an optimized, high-performance scalable host controller interface designed to utilize PCIe-based solid-state storage. NVMe is designed to provide efficient access to storage devices built with non-volatile memory, from current NAND flash technology to future, higher performing persistent memory technologies like Optane. NVMe is designed to meet serial bandwidth requirements and very high IOPs. It is based

on PCIe Gen 3 and can deliver up to 4GB/s bandwidth. Current NVMe is based on version 1.3 of the specification.

2.8.3 Intel® Rapid Storage Technology / SATA RAID

The CM246 PCH supports Intel® Rapid Storage Technology, providing both AHCI and integrated RAID functionality. The RAID capability provides high-performance RAID 0 and 1 functionality on the M.2 Slots. Other RAID features include hot spare support, SMART alerting, and RAID 0 auto replace. Software components include an Option ROM for pre-boot configuration and boot functionality, a Microsoft Windows compatible driver, and a user interface for configuration and management of the RAID capability of the PCH.



NOTE

Intel Rapid Storage Technology / SATA RAID is only supported if an M.2 SATA SSD module is used with another M.2 SATA SSD module. RAID is not available when mixing an M.2 NVMe SSD module and onboard SATA interface. CPU attached storage can also be used with NVMe SSD RAID options, functionality of RAID from the PCH on the NUC 9 Extreme/Pro Compute Element cannot be shared with functionality of RAID from the Baseboard. See Figure 3 for the M.2 Storage location on the NUC 9 Extreme/Pro Compute Element.

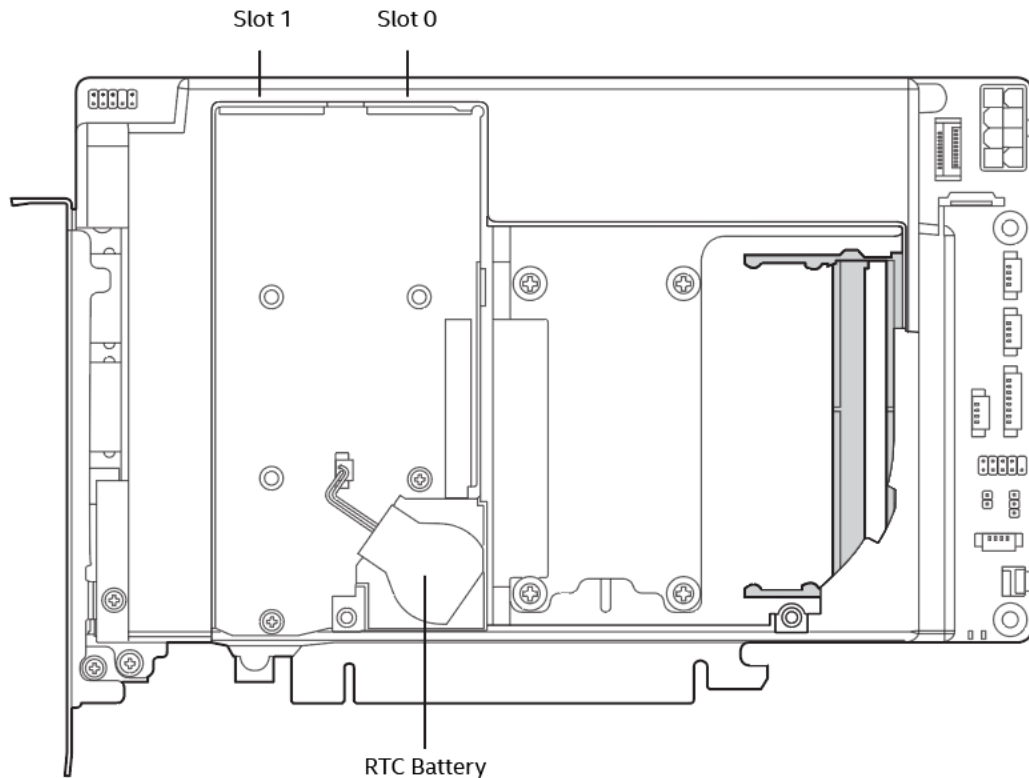

Figure 3. Location of NUC 9 Extreme/Pro Compute Element M.2 Slots and Battery

2.9 Real-Time Clock Subsystem

A coin-cell battery (CR2032) powers the real-time clock and CMOS memory. When the computer is not plugged into a wall socket, the battery has an estimated life of three years. When the computer is plugged in, the standby current from the power supply extends the life of the battery. The clock is accurate to ± 13 minutes/year at 25 °C with 3.3 VSB applied via the power supply 5 V STBY rail.



NOTE

If the battery and AC power fail, date and time values will be reset and the user will be notified during the POST.

When the voltage drops below a certain level, the BIOS Setup program settings stored in CMOS RAM (for example, the date and time) might not be accurate. Replace the battery with an equivalent one. Figure 3 shows the location of the battery.

2.10 LAN

The onboard LAN controllers consist of the following:

- Intel Gigabit Ethernet Controller I219-LM (10/100/1000 Mb/s)
- Intel Gigabit Ethernet Controller I210-AT (10/100/1000 Mb/s)
- RJ-45 LAN connectors with integrated status LEDs

Additional features of the LAN subsystem include:

- CSMA/CD protocol engine
- LAN connect interface between the Processor and the LAN controller
- Power management capabilities
 - ACPI technology support
 - LAN wake capabilities
- LAN subsystem software

2.10.1 Intel® Gigabit Ethernet Controller I219-LM

The Intel Gigabit Ethernet Controller I219-LM supports the following features:

- Compliant with the 1 Gb/s Ethernet 802.3, 802.3u, 802.3z, 802.3ab specifications
- Multi-speed operation: 10/100/1000 Mb/s
- Full-duplex operation at 10/100/1000 Mb/s; Half-duplex operation at 10/100 Mb/s
- Flow control support compliant with the 802.3X specification as well as the specific operation of asymmetrical flow control defined by 802.3z
- VLAN support compliant with the 802.1q specification
- Supports Jumbo Frames (up to 9 kB)
 - IEEE 1588 supports (Precision Time Protocol)
- MAC address filters: perfect match unicast filters, multicast hash filtering, broadcast filter, and promiscuous mode

2.10.2 Intel® Gigabit Ethernet Controller I210-AT

The Intel Gigabit Ethernet Controller I210-at supports the following features:

- Compliant with the 1 Gb/s Ethernet 802.3, 802.3u, 802.3z, 802.3ab specifications
- Multi-speed operation: 10/100/1000 Mb/s
- Full-duplex operation at 10/100/1000 Mb/s; Half-duplex operation at 10/100 Mb/s
- Flow control support compliant with the 802.3X specification as well as the specific operation of asymmetrical flow control defined by 802.3z
- Supports Jumbo Frames (up to 9 kB)
 - IEEE 1588 supports (Precision Time Protocol)
- MAC address filters: perfect match unicast filters, multicast hash filtering, broadcast filter, and promiscuous mode

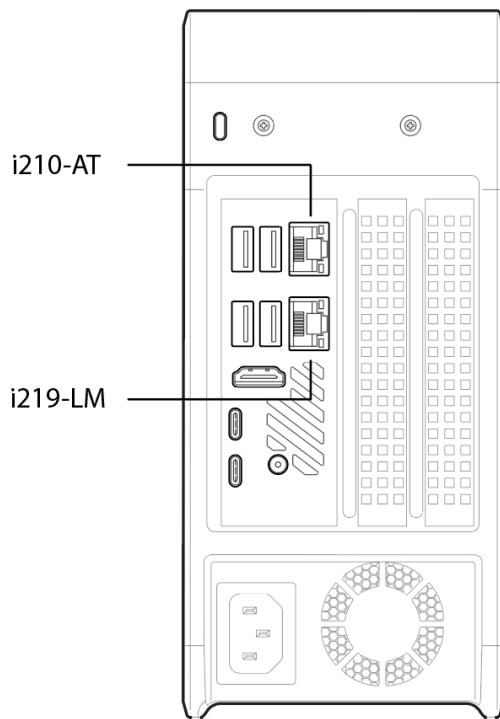

Figure 4. NUC 9 Extreme/Pro Kit LAN Controller Layout

2.10.3 LAN Software

LAN software and drivers are available from Intel's World Wide Web site.

For information about

Obtaining LAN software and drivers

Refer to

<http://downloadcenter.intel.com>

2.11 Intel® Security and Manageability Technologies

Intel® Security and Manageability Technologies provides tools and resources to help small business owners and IT organizations protect and manage their assets in a business or institutional environment.



NOTE

Software with security and/or manageability capability is required to take advantage of Intel platform security and/or management technologies.

2.11.1 Intel® vPro™ Technology

Intel® vPro™ Technology is a collection of platform capabilities that support enhanced manageability, security, virtualization and power efficiency. The key platform capabilities include:

- Intel® Active Management Technology (Intel® AMT) 12.0
- Intel® Virtualization (Intel® VT-x)
- Intel® Virtualization for Directed I/O (Intel® VT-d)
- Intel® Trusted Execution Technology (Intel® TXT)
- Intel® Identity Protection Technology (Intel® IPT)
- Intel® Software Guard Extensions (Intel® SGX)
- Intel® Transparent Supply Chain (Intel® TSC)
- Trusted Platform Module 2.0 (TPM)

For information about	Refer to
Intel® vPro Technology	http://support.intel.com/support/vpro/

2.11.1.1 Intel® Active Management Technology 12

When used with third-party management and security applications, Intel Active Management Technology (Intel® AMT) allows business owners and IT organizations to better discover, heal, and protect their networked computing assets.

Some of the features of Intel AMT include:

- Out-of-band (OOB) system access, to discover assets even while PCs are powered off
- Remote trouble-shooting and recovery, which allows remote diagnosis and recovery of systems after OS failures
- Hardware-based agent presence checking that automatically detects and alerts when critical software agents have been stopped or are missing
- Proactive network defense, which uses filters to block incoming threats while isolating infected clients before they impact the network
- Remote hardware and software asset tracking, helping to track computer assets and keep virus protection up-to-date
- Keyboard, video and mouse (KVM) remote control, which allows redirection of a managed system's video to a remote console which can then interact with it using the console's own mouse and keyboard



NOTE

Intel AMT requires a network connector and an Intel AMT enabled remote management console. Setup requires additional configuration of the platform.

For information about	Refer to
-----------------------	----------

Intel® Active Management Technology	http://www.intel.com/technology/platform-technology/intel-amt/index.htm
-------------------------------------	---

2.11.1.2 Intel® Virtualization Technology

Intel® Virtualization Technology (Intel® VT-x) is a hardware-assisted technology that, when combined with software-based virtualization solutions, provides maximum system utilization by consolidating multiple environments into a single server or client.



NOTE

A processor with Intel VT does not guarantee that virtualization will work on your system. Intel VT requires a computer system with a chipset, BIOS, enabling software and/or operating system, device drivers, and applications designed for this feature.

For information about	Refer to
-----------------------	----------

Intel® Virtualization Technology	http://www.intel.com/technology/virtualization/technology.htm
----------------------------------	---

2.11.1.3 Intel® Virtualization Technology for Directed I/O

Intel® Virtualization Technology for Directed I/O (Intel® VT-d) allows addresses in incoming I/O device memory transactions to be remapped to different host addresses. This provides Virtual Machine Monitor (VMM) software with:

- Improved reliability and security through device isolation using hardware assisted remapping.
- Improved I/O performance and availability by direct assignment of devices.

For information about	Refer to
-----------------------	----------

Intel® Virtualization Technology for Directed I/O	https://software.intel.com/en-us/node/139035?wapkw=vt+directed+io
---	---

2.11.1.4 Intel® Trusted Execution Technology

Intel® Trusted Execution Technology (Intel® TXT) is a hardware security solution that protects systems against software-based attacks by validating the behavior of key components at startup against a known good source. It requires that Intel VT be enabled and the presence of a TPM.

For information about	Refer to
Intel® Trusted Execution Technology	http://www.intel.com/content/www/us/en/architecture-and-technology/trusted-execution-technology/malware-reduction-general-technology.html

2.11.1.5 Intel® Identity Protection Technology

Intel® Identity Protection Technology (Intel® IPT) provides a simple way for websites and enterprises to validate that a user is logging in from a trusted computer. This is accomplished by using the Intel Manageability Engine embedded in the chipset to generate a six-digit number that, when coupled with a user name and password, will generate a One-Time Password (OTP) when visiting Intel IPT-enabled websites. Intel IPT eliminates the need for the additional token or key fob required previously for two-factor authentication.

For information about	Refer to
Intel® Identity Protection Technology	http://ipt.intel.com

2.11.1.6 Intel® Software Guard Extensions

Intel® Software Guard Extensions (Intel® SGX) is for application developers who are seeking to protect select code and data from disclosure or modification. Intel SGX makes such protections possible through the use of enclaves, which are protected areas of execution in memory. Application code can be put into an enclave by special instructions and software made available to developers via the Intel SGX Software Development Kit (SDK).

For information about	Refer to
Intel® Software Guard Extensions	https://software.intel.com/en-us/sgx

2.11.1.7 Intel® Transparent Supply Chain (TSC)

Intel® Transparent Supply Chain is being able to prove that all components used for Intel products were sourced from approved manufacturers and purchased from authorized suppliers or distributors. The components will be traceable to each finished goods serial number. TSC data aids in the detection of counterfeit, gray market, and/or components that do not conform to spec.

For information about	Refer to
Intel® Transparent Supply Chain	https://tsc.intel.com/nuc

2.11.1.8 Trusted Platform Module (TPM)

The TPM version 2.0 component is specifically designed to enhance platform security above-and-beyond the capabilities of today's software by providing a protected space for key operations and other security critical tasks. Using both hardware and software, the TPM protects encryption and signature keys at their most vulnerable stages—operations when the keys are being used unencrypted in plain-text form. The TPM shields unencrypted keys and platform authentication information from software-based attacks.



NOTE

Support for TPM v2.0 requires a UEFI-enabled operating system, such as Microsoft Windows 10.

TCM 2.0-compliant device:

NationZ TCM-Z32H330TC TPM v2.0

2.12 Power Management

Power management is implemented at several levels, including:

- Software support through Advanced Configuration and Power Interface (ACPI)
- Hardware support:
 - Power Input
 - LAN wake capabilities
 - Wake from USB

2.12.1 ACPI

ACPI gives the operating system direct control over the power management and Plug and Play functions of a computer. The use of ACPI with this board requires an operating system that provides full ACPI support. ACPI features include:

- Plug and Play (including bus and device enumeration)
- Power management control of individual devices, add-in boards (some add-in boards may require an ACPI-aware driver), video displays, and hard disk drives
- Methods for achieving less than 15-watt system operation in the power-on/standby sleeping state
- A Soft-off feature that enables the operating system to power-off the computer
- Support for a front panel power and sleep mode switch

Table 3 lists the system states based on how long the power switch is pressed, depending on how ACPI is configured with an ACPI-aware operating system.

Table 3. Effects of Pressing the Power Switch

If the system is in this state...	...and the power switch is pressed for	...the system enters this state
Off (ACPI G2/G5 – Soft off)	Less than four seconds	Power-on (ACPI G0 – working state)
On (ACPI G0 – working state)	Less than four seconds	Soft-off/Standby (ACPI G1 – sleeping state) ^{Note}
On (ACPI G0 – working state)	More than six seconds	Fail safe power-off (ACPI G2/G5 – Soft off)
Sleep (ACPI G1 – sleeping state)	Less than four seconds	Wake-up (ACPI G0 – working state)
Sleep (ACPI G1 – sleeping state)	More than six seconds	Power-off (ACPI G2/G5 – Soft off)

Note: Depending on power management settings in the operating system.

2.12.1.1 System States and Power States

Under ACPI, the operating system directs all system and device power state transitions. The operating system puts devices in and out of low-power states based on user preferences and knowledge of how devices are being used by applications. Devices that are not being used can be turned off. The operating system uses information from applications and user settings to put the system into a low-power state.

Table 4 lists the power states supported by the board along with the associated system power targets. See the ACPI specification for a complete description of the various system and power states.

Table 4. Power States and Targeted System Power

Global States	Sleeping States	Processor States	Device States
G0 – working state	S0 – working	C0 – working	D0 – working state.
G1 – sleeping state	S3 – Suspend to RAM. Context saved to RAM.	No power	D3 – no power except for wake-up logic.
G1 – sleeping state	S4 – Suspend to disk. Context saved to disk.	No power	D3 – no power except for wake-up logic.
G2/S5	S5 – Soft off. Context not saved. Cold boot is required.	No power	D3 – no power except for wake-up logic.
G3 – mechanical off AC power is disconnected from the computer.	No power to the system.	No power	D3 – no power for wake-up logic, except when provided by battery or external source.

Notes:

1. Total system power is dependent on the system configuration, including add-in boards and peripherals powered by the system chassis' power supply.
2. Dependent on the standby power consumption of wake-up devices used in the system.

2.12.1.2 Wake-up Devices and Events

Table 5 lists the devices or specific events that can wake the computer from specific states.

Table 5. Wake-up Devices and Events

Devices/events that wake up the system...	...from this sleep state	Comments
Power switch	S3, S4, S5 ¹	
RTC alarm	S3, S4, S5 ¹	Monitor to remain in sleep state
LAN	S3, S4, S5 ^{1,3}	"S5 WOL after G3" must be supported; monitor to remain in sleep state
WIFI	S3, S4, S5 ^{1,3}	Monitor to remain in sleep state
Bluetooth	S3 ¹ , S4	
USB	S3, S4, S5 ^{1,2,3}	Wake S4, S5 controlled by BIOS option (not after G3)
PCIE	S3, S4	Via WAKE; monitor to remain in sleep state
HDMI CEC	S3, S4, S5 ¹	Emulates power button push

Notes:

1. S4 implies operating system support only.
2. Will not wake from Deep S4/S5. USB S4/S5 Power is controlled by BIOS. USB S5 wake is controlled by BIOS. USB S4 wake is controlled by OS driver, not just BIOS option.
3. Windows Fast startup will block wake from LAN and USB from S5.



NOTE

The use of these wake-up events from an ACPI state requires an operating system that provides full ACPI support. In addition, software, drivers, and peripherals must fully support ACPI wake events.

2.12.2 Hardware Support

The board provides several power management hardware features, including:

- Wake from Power Button signal
When resuming from an AC power failure, the computer returns to the power state defined in the BIOS. Available states are "Power On", "Stay Off", and "Last State".
- LAN wake capabilities
Enables remote wake-up of the computer through a network. The LAN subsystem monitors network traffic at the Media Independent Interface. Upon detecting a Magic Packet* frame, the LAN subsystem asserts a wake-up signal that powers up the computer.
- Wake from USB
USB bus activity wakes the computer from an ACPI S3 state (not after G3).
- +5 V Standby Power Indicator LED
The standby power indicator LED shows that power is still present even when the computer appears to be off.



NOTE

The use of Wake from USB from an ACPI state requires an operating system that provides full ACPI support. Wake from USB requires the use of a USB peripheral that supports Wake from USB.

2.13 Audio Subsystem Software

Audio is supported through the HDMI 2.0a ports interface through the processor and supports eight full range channels of lossless audio formats per port. When using an encoded format (such as DTS-HD MA or Dolby True HD) the board supports a single 7.1 stream. When using an un-encoded format the board supports 8 discrete, un-encoded channels per HDMI port simultaneously, for a total of 16 discrete/un-encoded channels.

2.13.1 HDMI Audio Subsystem Software

HDMI Audio drivers are built into the Graphics driver and are available from Intel's website.

For information about	Refer to
Obtaining NUC software and drivers	https://downloadcenter.intel.com

2.13.2 Stereo/TOSLINK HD Audio Subsystem Software

The integrated Realtek ALC audio subsystem supports the following features:

- Analog line-out/Analog Headphone/Analog Microphone (front panel jack)
- Analog stereo line-out/TOSLINK out (back panel jack)
 - Analog Speakers only (Stereo)
 - SPDIF optical output formats up to compressed 5.1/7.1
- Support for 44.1 kHz/48 kHz/96 kHz/192 kHz sample rates on all analog outputs
- Support for 44.1 kHz/48 kHz/96 kHz sample rates on all analog inputs
- Front Panel Audio Jack Support (see Figure 5 for 3.5 mm audio jack pin out):
 - Speakers only (Stereo)
 - Headphones only (Stereo)
 - Microphone only (mono)
 - Combo Headphone (Stereo)/Microphone (mono)

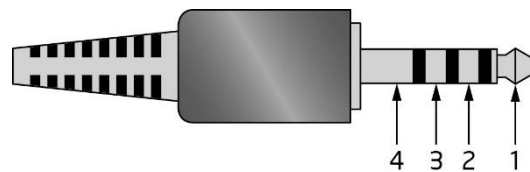

Pin Number	Pin Name	Description
1	Tip	Left Audio Out
2	Ring	Right Audio Out
3	Ring	Common/Ground
4	Sleeve	Audio In/MIC

Figure 5. 4-Pin 3.5 mm (1/8 inch) Audio Jack Pin Out

2.14 Connectors, Headers, and Expansion



CAUTION

Only the following connectors and headers have overcurrent protection: back panel USB, front panel USB, internal USB headers, PCI Express Slots, and M.2 slots.

All other connectors and headers are not overcurrent protected and should connect only to devices inside the computer's chassis, such as fans and internal peripherals. Do not use these connectors or headers to power devices external to the computer's chassis. A fault in the load presented by the external devices could cause damage to the computer, the power cable, and the external devices themselves.

Furthermore, improper connection of USB header single wire connectors may eventually overload the overcurrent protection and cause damage to the board.

This section describes the board's connectors and headers. The connectors and headers can be divided into these groups:

- Front panel I/O connectors
- Back panel I/O connectors
- Baseboard connectors and headers
- Interior chassis connectors and headers
- NUC Element Extreme/Pro board connectors and headers

2.14.1 Front Panel Connectors

Figure 6 indicates the location of the front panel connectors present on the chassis.

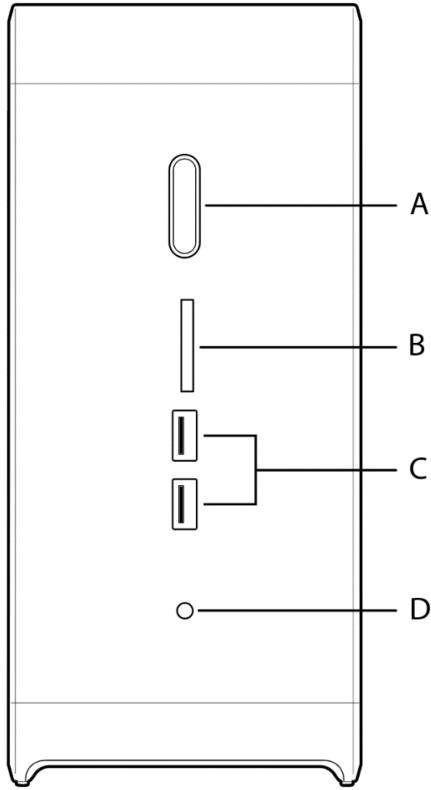

Item	Description
A	Power button (backlit)
B	UHS-II SDXC Reader
C	USB 3.1 Gen 2 Type A Ports (Black)
D	3.5mm Speaker/Headset

Figure 6. Front Panel Connectors

2.14.2 Back Panel Connectors

Figure 7 indicates the location of the back panel connectors present.

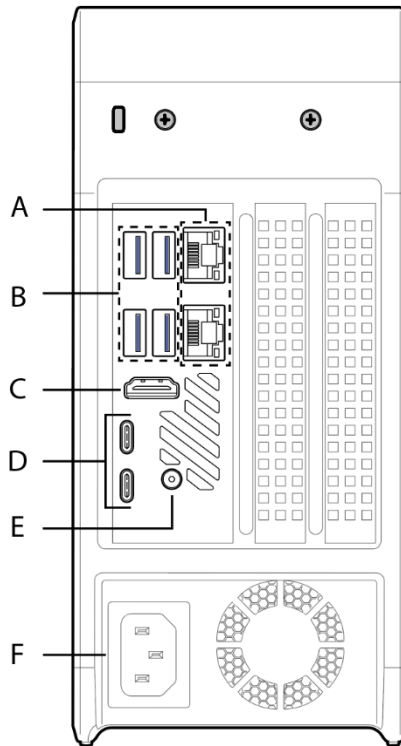

Item	Description
A	Lan Connector 1/2 (Connector 1 is 210AT, Connector 2 is 219LM)
B	USB 3.1 Gen 2 Type A Ports
C	HDMI Port
D	Thunderbolt 3 ports
E	Stereo/TOSLINK combo jack
F	AC Power input (C13)

Figure 7. Back Panel Connectors

2.14.3 Baseboard Connectors

The NUC 9 Extreme/Pro Kit has a baseboard that expands the connectivity of the NUC 9 Extreme/Pro Compute Element through the usage of PCI Express lanes. Connectors that are used for expansion through the NUC Element gold fingers to the Baseboard are shown in Table 6. Figure 8 shows a top down view of all connectors and headers on the BBWC1B Baseboard.

Table 6. Intel BBWC1B Baseboard configuration

Connector Type	Description
PCIe 3.0 x16 Slot	The NUC Extreme/Pro Compute Element input connector (black)
PCIe 3.0 x4 M.2 Slot	M.2 slot that is configured for NVMe only (covered by heatsink)
PCIe 3.0 x16 Slot	PCIe 3.0 x16 standard compliant slot (blue)
PCIe 3.0 x4 Slot	PCIe 3.0 x4 standard compliant slot (black)
PCI Express Bifurcation Settings	
When a single PCIe 3.0 x16 add-in card is used in the PCIe 3.0 x16 slot it can access the full PCIe 3.0 x16 bandwidth. When the M.2 slot, the PCIe x4 slot, or both are used the x16 slot is reduced to x8.	
Note PCIe 3.0 x16 Bifurcation is supported to a maximum of three PCI Express devices (x8 + 2 x4).	

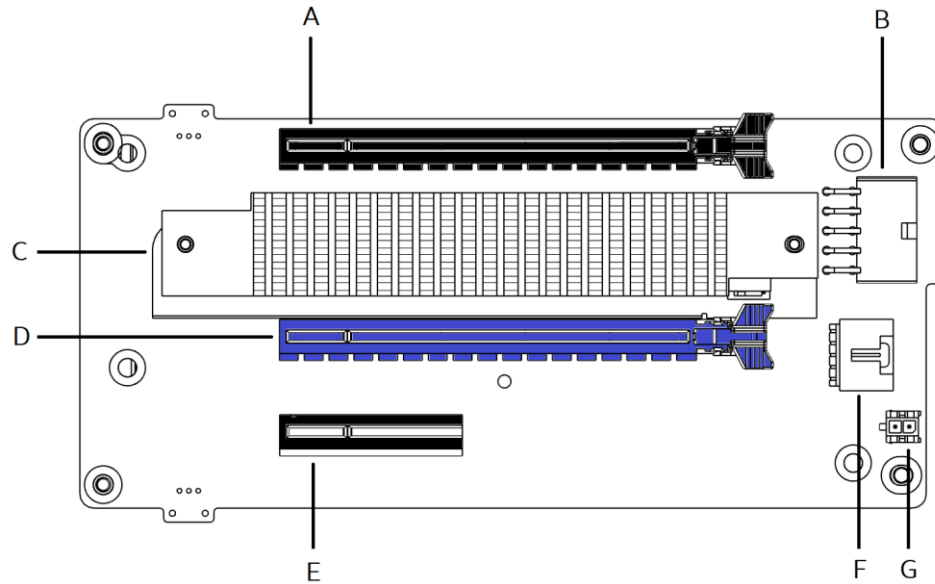

Item	Description
A	NUC 9 Extreme/Pro PCIe 3.0 x16 Slot input (black)
B	BBWC1B Power input connector
C	PCIe 3.0 x4 M.2 Slot 2242/2280/22110 NVMe only (with heatsink)
D	PCIe 3.0 x16 Slot (blue)
E	PCIe 3.0 x4 Slot (black)
F	PMBUS 5pin header
G	5VSTBY header (disconnected)

Figure 8. BBWC1B Baseboard Connectors

2.14.4 Interior Chassis Connectors

The bottom front portion of the NUC 9 Extreme/Pro chassis has interior headers that connect to the NUC 9 Extreme/Pro Compute Element. Figure 9 shows a simplified view of the front panel connectors.

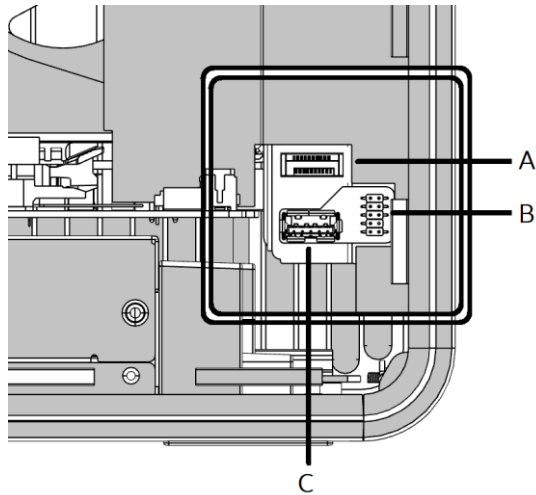

Item	Description
A	20pin Internal Desktop Type-C Key B Header
B	Internal Front Panel Audio Header
C	Internal USB 3.1 Gen 2 Type A Port

Figure 9. NUC 9 Extreme/Pro Chassis Interior Front Panel Headers and Connectors

2.15 NUC 9 Extreme/Pro Element Headers and Connectors

The NUC 9 Extreme/Pro Compute Element contains headers and connectors necessary for function inside the NUC 9 Extreme/Pro Kit. Figure 10 shows the headers and connectors that are utilized by default and for expansion.

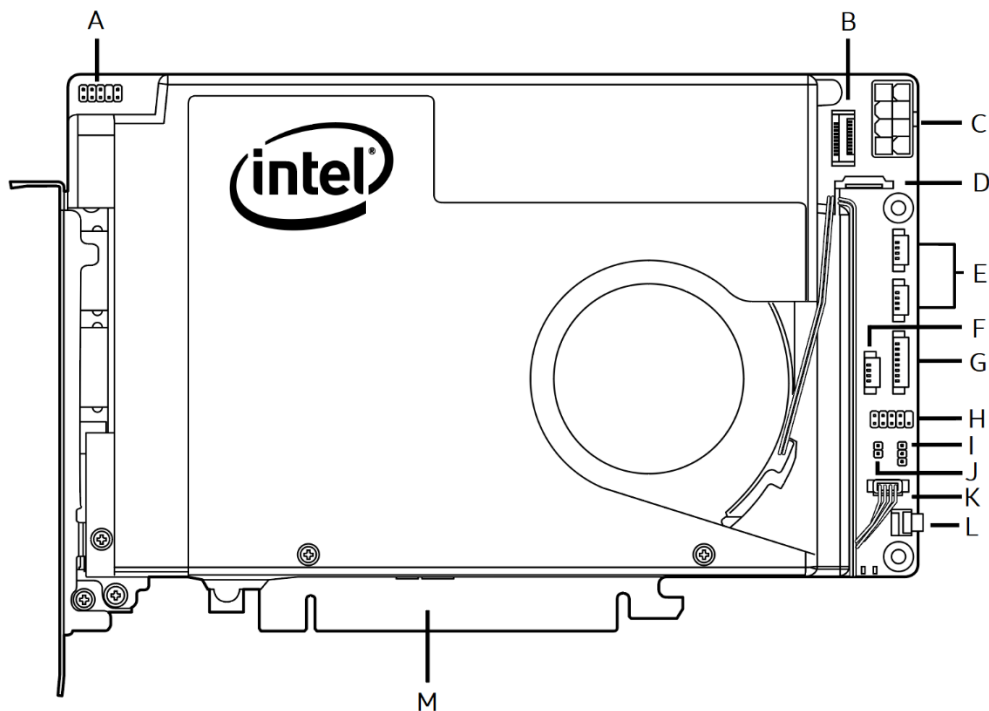

Figure 10. NUC 9 Extreme/Pro Compute Element Headers and Connectors

Table 7. Components shown in Figure 10.

Item from Figure 10	Description
A	Front Panel Audio Header
B	Internal USB 3.1 Gen 2 Type-C 20pin Header (Key B)
C	EPS 8 Pin Power Connector (see ATX Power Supply Specification Standard)
D	Internal FPC Style SATA/Power connector for optional 2.5in drive operation
E	USB 2.0 4 pin Header x 2
F	Internal CEC Pulse8 Header
G	Internal 8pin Dual PWM Fan header
H	9-pin Front Panel IO Header
I	3-pin BIOS Security Jumper
J	2-pin MEBX Reset Jumper
K	NUC Card 4pin PWM Fan Header
L	Power Button
M	NUC 9 Extreme/Pro Compute Element PCIe 3.0 x16 Gold Fingers

2.15.1 Signal Tables for Headers and Connectors

This section more clearly defines the pinouts and connector types used in Table 7.

A - 10-pin Front Panel Audio Header

This connector is a 2 x 5 header with a 2.0mm pitch. The empty pin 8 is defined as the key.

A, Front Panel Audio Header	Pin Number	Pin Definition - Signal
	1	Port1L
	2	Ground
	3	Port1R
	4	Presence#
	5	Port2R
	6	Sense1_Ret
	7	Sense_Send
	8	(EMPTY)
	9	Port2L
	10	Sense2_Ret

B - Internal USB 3.1 Gen 2 Type-C 20pin Header (Key B)

C, Internal USB 3.1 Gen 2 Type-C 20pin Header (Key B)	Pin Number	Signal	Pin Number	Signal
	1	Ground	11	Ground
	2	TX1+	12	TX2-
	3	TX1-	13	TX2+
	4	Ground	14	Ground
	5	RX1+	15	RX2-
	6	RX1-	16	RX2+
	7	Ground	17	Ground
	8	D1+	18	D2+
	9	D1-	19	D2-
	10	VBUS	20	VBUS

C - EPS 8 Pin Power Connector

The EPS 8 Pin Power Connector follows the ATX standard layout and requirements. With one side being Ground and the opposite side with the connector lock being 12V. The NUC 9 Extreme/Pro Compute element can utilize 12-19V input, while the NUC 9 Extreme/Pro Kit provides the standard ATX 12V.

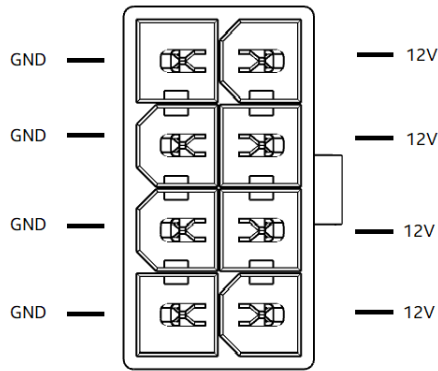

D - Internal FPC Style SATA/Power connector for optional 2.5in drive operation

Note* This header is for use with the NUC 9 Extreme/Pro Compute Element only

D, Internal FPC SATA/Power connector, ZIF FPC/FFC with lock.		Pin Number	Signal	Pin Number	Signal
	1	+5V	2	+5V	
	3	+5V	4	+5V	
	5	NC	6	NC	
	7	NC	8	DEVSLP	
	9	GND	10	GND	
	11	SATA_RX_P	12	SATA_RX_N	
	13	GND	14	SATA_TX_N	
	15	SATA_TX_P	16	GND	

E - USB 2.0 4 pin Header

Molex part number 53398-0471, 1.25mm Pitch PicoBlade* Header, Surface Mount, Vertical, Lead-Free, 4 Circuits.

E, USB 2.0 Header		Pin Number	Pin Definition - Signal
	1	+5V DC power	
	2	D - Data	
	3	D + Data	
	4	Ground	

F - Internal 8pin Dual PWM Fan header

Molex part number 53398-0867, 1.25mm Pitch PicoBlade* Header, Surface Mount, Vertical, Lead-Free, 8 circuits.

G, Dual PWM Fan Header		Pin Number	Pin Definition - Signal
	1	Ground	
	2	Ground	

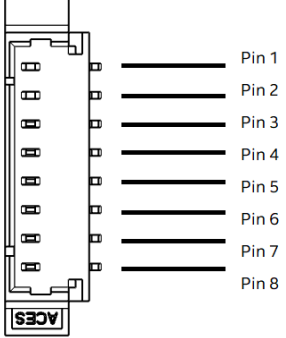
	3	Tachometer 1
	4	Pulse-Width Modulation (PWM) 1
	5	Tachometer 2
	6	Pulse-Width Modulation (PWM) 2
	7	+12V DC Power
	8	+12V DC Power

G - Internal CEC Pulse8 Header

Connector is a 1 x 4, 1.25mm pitch; Molex PicoBlade or equivalent size.

Molex part number 53398-0471, 1.25mm Pitch PicoBlade* Header, Surface Mount, Vertical, Lead-Free, 4 Circuits.

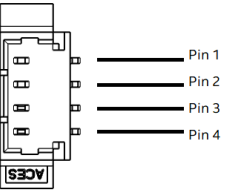
H, Pulse 8 Header	Pin Number	Pin Definition - Signal
	1	5VSTBY
	2	Ground
	3	Power_Switch#
	4	HDMI_CEC

H - 10-pin Front Panel IO Header

Connector is a 2 x 5, 2.0mm pitch connector.

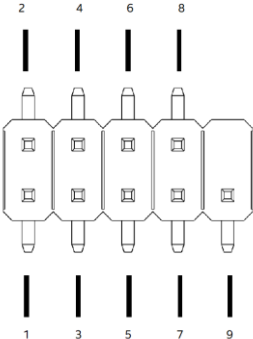
I, Front Panel Header	Pin Number	Signal Name	Description
	1	HDD_POWER_LED	Pull-up 750Ω to +5V
	2	POWER_LED_MAIN	[Out] Front panel LED (main color)
	3	HDD_LED#	[Out] HDD activity LED
	4	POWER_LED_ALT	[Out] Front panel LED (alt color)
	5	GROUND	Ground
	6	POWER_SWITCH#	[In] Power switch
	7	RESET SWITCH#	[In] Reset switch
	8	GROUND	Ground
	9	+5V_DC (1A)(Vcc)	Power
	10	Key (EMPTY)	No Pin

I - 3-pin BIOS Security Header

J, 3-pin BIOS Security Header	Pin Setting	BIOS Security setting behavior
-------------------------------	-------------	--------------------------------

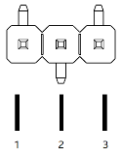
	1 & 2	Pins 1&2: jumper position for Normal mode
	2 & 3	Pins 2&3: jumper position for Lockdown mode
	OPEN	No jumper: Recovery mode

J - 2-pin MEBX Reset Jumper

Note* This header is non-functional on the NUC 9 Extreme

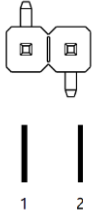
K, 2-pin MEBX Reset Jumper	Pin Setting	BIOS Security setting behavior
	Closed	Pins 1&2: jumper installed for RTCRST
	OPEN	No jumper: Normal operation

K - NUC Card 4pin PWM Fan Header

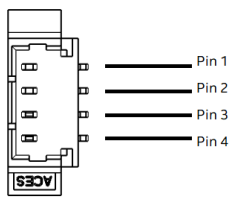
L, NUC Blower 4pin PWM Header	Pin Number	Pin Definition - Signal
	1	Ground
	2	Tachometer
	3	+12V
	4	Pulse-Width Modulation (PWM)

2.16 Wireless Network Module

The Intel WI-FI 6 AX200 module provides hi-speed wireless connectivity provided with the following capabilities:

- Compliant IEEE 802.11abgn, 802.11ac, 802.11ax, 802.11e, 802.11i, 802.11h, 802.11w specifications
- Maximum bandwidth of 2.4Gbps
- Dual Mode Bluetooth* 5
- OS certified with : Microsoft Windows 10, Linux* (most features not available on Linux)
- Wi-Fi Direct* for peer to peer device connections
- Wi-Fi Miracast Source
- Intel® Wireless Display 6.0
- Wi-Fi Direct for peer to peer device connections
- Authentication: WPA and WPA2* Personal and Enterprise; WPA3*(Pending OS Support), 802.1X (EAP-TLS, TTLS, PEAP, LEAP, EAP-FAST), EAP-SIM, EAP-AKA
- Encryption: 64-bit and 128-bit WEP, AES-CCMP, 256-bit AES-GCM, TKIP

- Intel® vPro™ Technology enabled on NUC9VXQNX and NUC9V7QNX

2.17 Antenna Connectors

The NUC 9 Extreme/Pro Kit wireless module has front panel internal antennas that connect to the NUC 9 Extreme/Pro Compute Element MMCX style connectors. For wireless and Bluetooth operation appropriate antennas will be required. Figure 11 shows the location of the two antenna connectors on the NUC 9 Extreme/Pro Compute Element

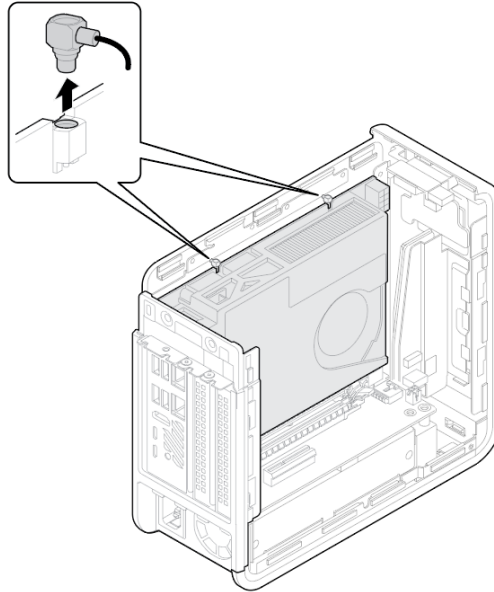

Figure 11. Location of the Antenna Connectors

The wireless module on the NUC 9 Extreme/Pro Compute element is the Intel WIFI AX200D2WL and uses a standard 2x2 mm size RF micro coaxial receptacle (connector) with an outer diameter of 1.5 mm as defined in the PCI-E M.2 Specification, the coaxial receptacle is then changed to the MMCX Micromate style connector for more robust connection in chassis.

2.18 Internal Power Supply

The Intel® NUC 9 Extreme/Pro Kit has an internal power supply that takes in AC 100-240V and outputs DC 12V, 3.3V, and 5Vsb. The form factor is compliant with the Flex-ATX specification.

The default power supply installed in the NUC 9 Extreme/Pro Kit is a FSP500-30AS 500W 80+Platinum rated supply.

Table 8. Power supply rating table.

Model No. FSP500-30AS			
AC Input	100-240V~, 6-3A, 50-60Hz		
DC Output	+3.3V	+12V	+5Vsb

	14.0A	40.41A	3.0A
	485W Max		15W
Total output continuous shall not exceed	500W		

The internal power supply FSP500-30AS 500W features the following cables:

- EPS12V 8pin power connector for Intel® NUC Extreme/Pro Element
- PCI Express 8pin right angle power connector*
- PCI Express 6+2pin straight power connector*
- PMBUS 5pin connector



NOTE

The PCI Express power connectors share a single power cable and are designed to be used independently of each other.



CAUTION

Disconnect the attached AC power cable before you open or service the device. Installing or removing devices from the Intel® NUC 9 Extreme/Pro Kit while a power source is connected to the Kit may cause damage to the Intel® NUC 9 Extreme/Pro Kit, operating system corruption, create a no boot condition or result in data loss.

2.19 Add-in Card Limitations

The Intel® NUC 9 Extreme/Pro Kit supports the installation of add-in PCIe cards. The PCI Express 3.0 x16 and 3.0 x4 connectors on the baseboard mentioned in Section 2.14.3 are designed to accept PCI Express compliant devices. The table below demonstrates the maximum accepted dimensions and specifications for add-in cards.

Table 9. PCI Express Add-in Cards Limitations

Dimensions			
Add-in Card Type	Maximum Length	Maximum Width	Maximum Height
PCI Express 3.0 x16 Add-in Card Dual Slot	202mm	Dual Slot Spec limit Total 39mm (34.8mm Front components +2.7mm rear backplate +1.7mm PCB thickness)	131mm From Card edge to absolute top most component or cable of card
PCI Express 3.0 x16 Add-in Card Single Slot	202mm	Single Slot	131mm From Card edge to absolute top most component or cable of card
PCI Express 3.0 x4 Add-in Card Slot	202mm	Single Slot	131mm From Card edge to absolute top most component or cable of card

NOTE* When a Dual Slot card is used in the PCIe x16 slot the PCIe x4 slot is inaccessible.

The maximum power consumption supported for add-in card design is 225W (150W from PCI Express 6+2/8pin + 75W from PCI Express Slot).

For a list of validated and compatible add-in cards go to the Inte® Product Compatibility Tool
<https://compatibleproducts.intel.com/ProductDetails?activeModule=Intel%C2%AE%20NUC>

2.20 NUC 9 Extreme/Pro Kit Dimensions

The following figures illustrate the mechanical form factor for the NUC 9 Extreme/Pro Kit. All dimensions are shown in millimeters (mm).

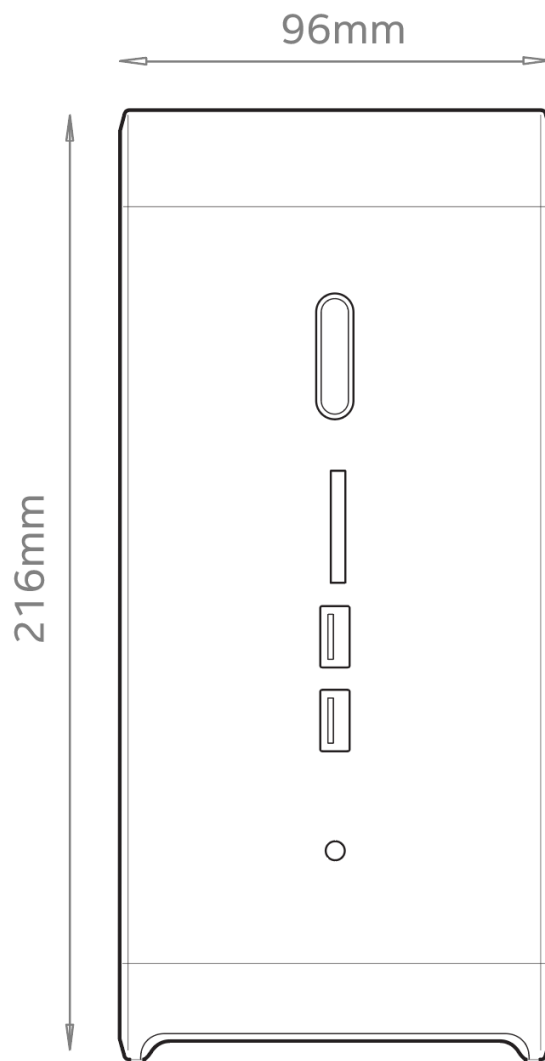

Figure 12. Front Side

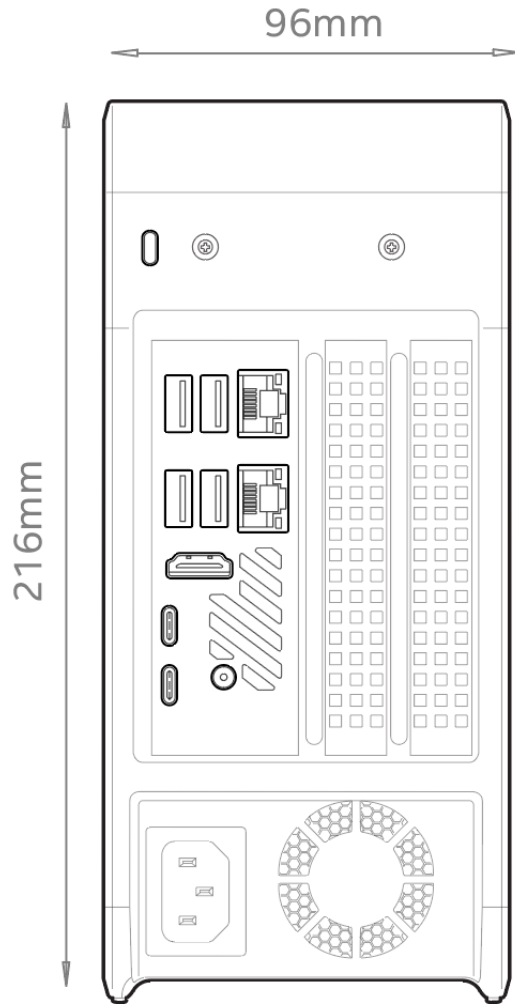

Figure 13. Back Side

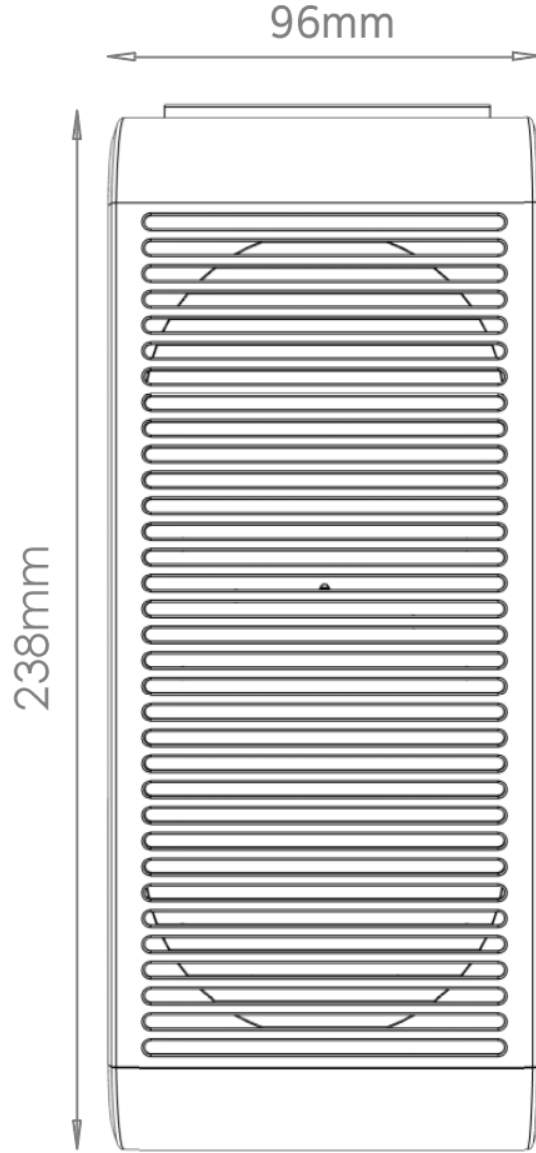

Figure 14. Top Side

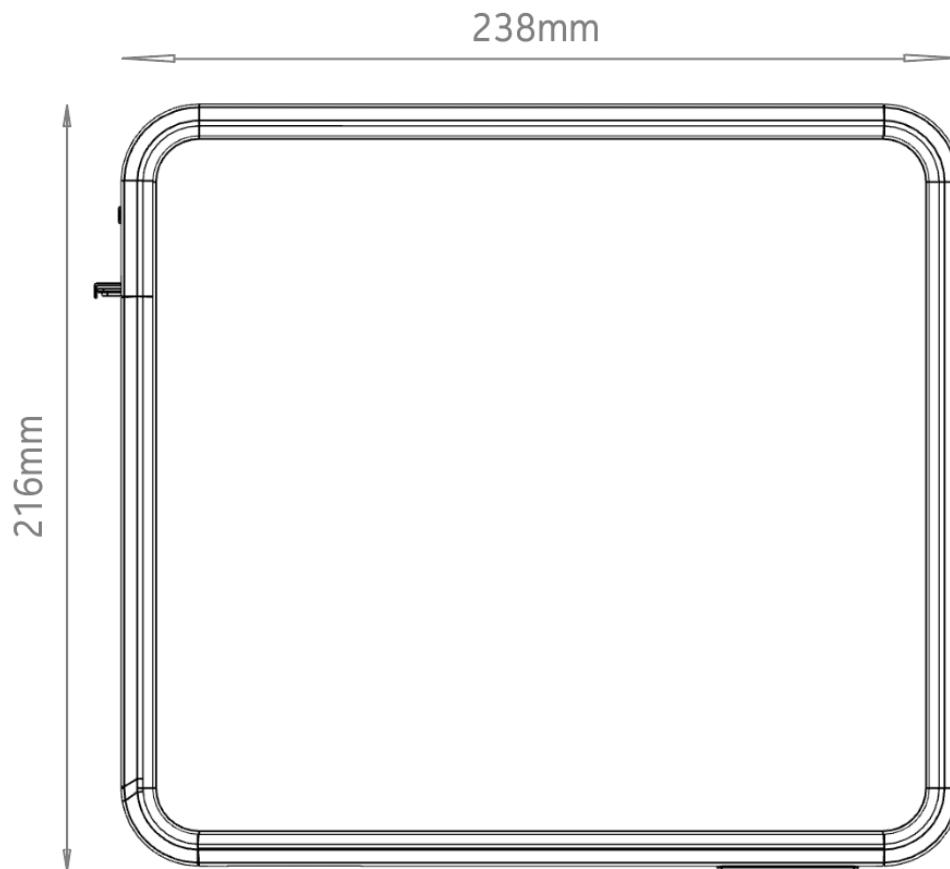

Figure 15. Side Panel

2.21 Thermal Considerations



CAUTION

The NUC 9 Extreme/Pro Kit is designed to take in airflow from the bottom and sides through the ventilated panels and exhausts through the top. Failure to ensure appropriate airflow may result in reduced performance of both the processor and/or voltage regulator or, in some instances, damage to the board.

All responsibility for determining the adequacy of any thermal or system design remains solely with the system integrator. Intel makes no warranties or representations that merely following the instructions presented in this document will result in a system with adequate thermal performance.



CAUTION

Ensure that the ambient temperature does not exceed the board's maximum operating temperature. Failure to do so could cause components to exceed their maximum case temperature

and malfunction. For information about the maximum operating temperature, see the environmental specifications in Section 2.23.



CAUTION

Ensure that proper airflow is maintained in the processor voltage regulator circuit. Failure to do so may result in shorter than expected product lifetime.

2.22 Reliability

The demonstrated Mean Time Between Failures (MTBF) is done through 24/7 testing. Full Intel® NUC systems in chassis with memory, SSD or HDD, and fans are run at 100% of target PWM for 90 days while running system wide stress inducing software in a 35 °C ambient air temperature chamber. The demonstrated MTBF for Intel NUC Extreme/Pro Kit is 50,000 hours.

2.23 Environmental

Table 10 lists the environmental specifications for the Intel® NUC 9 Extreme/Pro Kit.

Table 10. Environmental Specifications

Parameter	Specification		
Temperature			
Sustained Storage Limits (i.e. warehouse)	-20 °C to +40 °C		
Short Duration Limits (i.e. shipping)	-40 °C to +60 °C		
Ambient Operating – NUC Kit*	0 °C to +35 °C		
* Processor performance may automatically decrease when the system exceeds ambient operating temperature ranges above.			
Shock (Board)			
Unpackaged	25 g trapezoidal waveform		
	Velocity change of 170 inches/s ²		
Packaged	Free fall package drop machine set to the height determined by the weight of the package.		
	Product Weight (pounds)	Non-palletized Product drop height (inches)	Palletized drop heights (single product) (inches)
	<20	36	N/A
	21-40	30	N/A
	41-80	24	N/A
	81-100	18	12
100-120	12	9	
Vibration (System)			
Unpackaged	Random profile 5 Hz @ 0.001 g ² /Hz to 20 Hz @ 0.01 g ² /Hz(slope up)		
	20 Hz to 500 Hz @ 0.01 g ² /Hz (flat)		
	Input acceleration is 2.20g RMS		
Packaged	Random profile 5 Hz @ 0.01 g ² /Hz to 20 Hz @ 0.02 g ² /Hz(slope up)		
	20 Hz to 500 Hz @ 0.02 g ² /Hz (flat)		
	Input acceleration is 3.13g RMS		

Note: Before attempting to operate the Intel® NUC 9 Extreme/Pro Kit, the overall temperature of the system must be above the minimum operating temperature specified. It is recommended that the system temperature be at least room temperature before attempting to power on the NUC 9 Extreme/Pro Kit. The operating and non-operating environment must avoid condensing humidity.

3 Overview of BIOS Features

3.1 Introduction

The board uses Intel AMI BIOS core that is stored in the Serial Peripheral Interface Flash Memory (SPI Flash) and can be updated using a disk-based program. The SPI Flash contains the Visual BIOS Setup program, POST, the PCI auto-configuration utility, LAN EEPROM information, and Plug and Play support.

The BIOS displays a message during POST identifying the type of BIOS and a revision code. The initial production BIOSs are identified as TBD.

The Visual BIOS Setup program can be used to view and change the BIOS settings for the computer. The BIOS Setup program is accessed by pressing the <F2> key after the Power-On Self-Test (POST) memory test begins and before the operating system boot begins.



BIOS FLASH MEMORY ORGANIZATION

The Serial Peripheral Interface Flash Memory (SPI Flash) includes a 16 MB flash memory device.

3.2 System Management BIOS (SMBIOS)

SMBIOS is a Desktop Management Interface (DMI) compliant method for managing computers in a managed network.

The main component of SMBIOS is the Management Information Format (MIF) database, which contains information about the computing system and its components. Using SMBIOS, a system administrator can obtain the system types, capabilities, operational status, and installation dates for system components. The MIF database defines the data and provides the method for accessing this information. The BIOS enables applications such as third-party management software to use SMBIOS. The BIOS stores and reports the following SMBIOS information:

- BIOS data, such as the BIOS revision level
- Fixed-system data, such as peripherals, serial numbers, and asset tags
- Resource data, such as memory size, cache size, and processor speed
- Dynamic data, such as event detection and error logging

Non-Plug and Play operating systems require an additional interface for obtaining the SMBIOS information. The BIOS supports an SMBIOS table interface for such operating systems. Using this support, an SMBIOS service-level application running on a non-Plug and Play operating system can obtain the SMBIOS information. Additional board information can be found in the BIOS under the Additional Information header under the Main BIOS page.

3.3 Legacy USB Support

Legacy USB support enables USB devices to be used even when the operating system's USB drivers are not yet available. Legacy USB support is used to access the BIOS Setup program, and

to install an operating system that supports USB. By default, Legacy USB support is set to Enabled.

Legacy USB support operates as follows:

1. When you apply power to the computer, legacy support is disabled.
2. POST begins.
3. Legacy USB support is enabled by the BIOS allowing you to use a USB keyboard to enter and configure the BIOS Setup program and the maintenance menu.
4. POST completes.
5. The operating system loads. While the operating system is loading, USB keyboards and mice are recognized and may be used to configure the operating system. (Keyboards and mice are not recognized during this period if Legacy USB support was set to Disabled in the BIOS Setup program.)
6. After the operating system loads the USB drivers, all legacy and non-legacy USB devices are recognized by the operating system, and Legacy USB support from the BIOS is no longer used.

To install an operating system that supports USB, verify that Legacy USB support in the BIOS Setup program is set to Enabled and follow the operating system's installation instructions.

3.4 BIOS Updates

The BIOS can be updated using one of the following methods:

- Intel® Express BIOS Update utility, which enables automated updating while in the Windows environment. Using this utility, the BIOS can be updated from a file on a hard disk, a USB drive, a CD-ROM, or from the file location on the Web.
- Intel® F7 switch during POST allows a user to select where the BIOS Capsule file .CAP file is located and perform the update from that location/device. This is similar to performing a BIOS Recovery without removing the BIOS configuration jumper. The F7 switch supports FAT, FAT32, and NTFS format storage.

Both utilities verify that the updated BIOS matches the target system to prevent accidentally installing an incompatible BIOS.



NOTE

Review the instructions distributed with the upgrade utility before attempting a BIOS update.

For information about	Refer to
BIOS update utilities	https://www.intel.com/content/www/us/en/support/articles/000033291.html

3.4.1 Language Support

The BIOS Setup program and help messages are supported in US English. Check the Intel web site for support.

3.4.2 BIOS Recovery

It is unlikely that anything will interrupt a BIOS update; however, if an interruption occurs, the BIOS could be damaged. Table 11 lists the drives and media types that can and cannot be used for BIOS recovery. The BIOS recovery media does not need to be made bootable.

Table 11. Acceptable Drives/Media Types for BIOS Recovery

Media Type ^(Note)	Can be used for BIOS recovery?
Hard disk drive (connected to SATA or USB)	Yes
CD/DVD drive (connected to USB)	Yes
USB flash drive	Yes



NOTE

Supported file systems for BIOS recovery:

- *NTFS (sparse, compressed, or encrypted files are not supported)*
- *FAT32*
- *FAT16*
- *FAT12*
- *ISO 9660*

For information about

Refer to

BIOS recovery

<https://www.intel.com/content/www/us/en/support/articles/000033291/>

3.5 Boot Options

In the BIOS Setup program, the user can choose to boot from a hard drive, optical drive, removable drive, or the network. The default setting is for the optical drive to be the first boot device, the hard drive second, removable drive third, and the network fourth.



NOTE

Optical drives are not supported by the onboard SATA connectors. Optical drives are supported only via the USB interfaces.

3.5.1 Network Boot

The network can be selected as a boot device. This selection allows booting from the onboard LAN or a network add-in card with a remote boot ROM installed.

Pressing the <F12> key during POST automatically forces booting from the LAN. To use this key during POST, the User Access Level in the BIOS Setup program's Security menu must be set to Full.

3.5.2 Booting Without Attached Devices

For use in embedded applications, the BIOS has been designed so that after passing the POST, the operating system loader is invoked even if the following devices are not present:

- Video cable
- Keyboard
- Mouse

3.5.3 Boot Device Selection During POST

Pressing the <F10> key during POST causes a boot device menu to be displayed. This menu displays the list of available boot devices. Table 12 lists the boot device menu options.

Table 12. Boot Device Menu Options

Boot Device Menu Function Keys	Description
<↑> or <↓>	Selects a default boot device
<Enter>	Exits the menu, and boots from the selected device
<Esc>	Exits the menu and boots according to the boot priority defined through BIOS setup

3.5.4 Power Button Menu

As an alternative to Back-to-BIOS Mode or normal POST Hotkeys, the user can use the power button to access a menu. The Power Button Menu is accessible via the following sequence:

1. System is in S4/S5 (not G3)
2. User pushes the power button and holds it down for 3 seconds

3. The system will emit three short beeps from the front panel (FP) audio port, then stop to signal the user to release the power button. The FP power button LED will also change from Blue to Amber when the user can release the power button.
4. User releases the power button before the 4-second shutdown override

If this boot path is taken, the BIOS will use default settings, ignoring settings in VPD where possible.

At the point where Setup Entry/Boot would be in the normal boot path, the BIOS will display the following prompt and wait for a keystroke:

- [ESC] Normal Boot
- [F2] Intel Visual BIOS
- [F3] Disable Fast Boot
- [F4] BIOS Recovery
- [F7] Update BIOS
- [F10] Enter Boot Menu
- [F12] Network Boot

[F2] Enter Setup is displayed instead if Visual BIOS is not supported.

[F3] Disable Fast Boot is only displayed if at least one Fast Boot optimization is enabled.

If an unrecognized key is hit, then the BIOS will beep and wait for another keystroke. If one of the listed hotkeys is hit, the BIOS will follow the indicated boot path. Password requirements must still be honored.

If Disable Fast Boot is selected, the BIOS will disable all Fast Boot optimizations and reset the system.

3.6 Hard Disk Drive Password Security Feature

The Hard Disk Drive Password Security feature blocks read and write accesses to the hard disk drive until the correct password is given. Hard Disk Drive Passwords are set in BIOS SETUP and are prompted for during BIOS POST. For convenient support of S3 resume, the system BIOS will automatically unlock drives on resume from S3. Valid password characters are A-Z, a-z, and 0-9. Passwords may be up to 19 characters in length.

The User hard disk drive password, when installed, will be required upon each power-cycle until the Master Key or User hard disk drive password is submitted.

The Master Key hard disk drive password, when installed, will not lock the drive. The Master Key hard disk drive password exists as an unlock override in the event that the User hard disk drive password is forgotten. Only the installation of the User hard disk drive password will cause a hard disk to be locked upon a system power-cycle.

Table 13 shows the effects of setting the Hard Disk Drive Passwords.

Table 13. Master Key and User Hard Drive Password Functions

Password Set	Password During Boot
Neither	None
Master only	None
User only	User only
Master and User Set	Master or User

During every POST, if a User hard disk drive password is set, POST execution will pause with the following prompt to force the user to enter the Master Key or User hard disk drive password:

“Enter Hard Disk Drive Password:”

Upon successful entry of the Master Key or User hard disk drive password, the system will continue with normal POST.

If the hard disk drive password is not correctly entered, the system will go back to the above prompt. The user will have three attempts to correctly enter the hard disk drive password. After the third unsuccessful hard disk drive password attempt, the system will halt with the message:

“Hard Disk Drive Password Entry Error”

A manual power cycle will be required to resume system operation.



NOTE

As implemented on Intel NUC Extreme/Pro Kit, Hard Disk Drive Password Security is only supported on either M.2 ports on the NUC 9 Extreme/Pro Compute Element. The passwords are stored on the hard disk drive so if the drive is relocated to another computer that does not support Hard Disk Drive Password Security feature, the drive will not be accessible.

3.7 BIOS Security Features

The BIOS includes security features that restrict access to the BIOS Setup program and who can boot the computer. A supervisor password and a user password can be set for the BIOS Setup program and for booting the computer, with the following restrictions:

- The supervisor password gives unrestricted access to view and change all the Setup options in the BIOS Setup program. This is the supervisor mode.
- The user password gives restricted access to view and change Setup options in the BIOS Setup program. This is the user mode.
- If only the supervisor password is set, pressing the <Enter> key at the password prompt of the BIOS Setup program allows the user restricted access to Setup.
- If both the supervisor and user passwords are set, users can enter either the supervisor password or the user password to access Setup. Users have access to Setup respective to which password is entered.
- Setting the user password restricts who can boot the computer. The password prompt will be displayed before the computer is booted. If only the supervisor password is set, the computer boots without asking for a password. If both passwords are set, the user can enter either password to boot the computer.
- For enhanced security, use different passwords for the supervisor and user passwords.
- Valid password characters are A-Z, a-z, and 0-9. Passwords may be up to 16 characters in length.
- To clear a set password, enter a blank password after entering the existing password.

Table 14 shows the effects of setting the supervisor password and user password. This table is for reference only and is not displayed on the screen.

Table 14. Supervisor and User Password Functions

Password Set	Supervisor Mode	User Mode	Setup Options	Password to Enter Setup	Password During Boot
Neither	Can change all options (Note)	Can change all options (Note)	None	None	None
Supervisor only	Can change all options	Can change a limited number of options	Supervisor Password	Supervisor	None
User only	N/A	Can change all options	Enter Password Clear User Password	User	User
Supervisor and user set	Can change all options	Can change a limited number of options	Supervisor Password Enter Password	Supervisor or user	Supervisor or user

Note: If no password is set, any user can change all Setup options.

3.8 Error Messages

3.8.1 BIOS Error Messages

Table 15 lists the error messages and provides a brief description of each.

Table 15. BIOS Error Messages

Error Message	Explanation
CMOS Battery Low	The battery may be losing power. Replace the battery soon.
CMOS Checksum Bad	The CMOS checksum is incorrect. CMOS memory may have been corrupted. Run Setup to reset values.
Memory Size Decreased	Memory size has decreased since the last boot. If no memory was removed, then memory may be bad.
No Boot Device Available	System did not find a device to boot.

4 Characterized Errata

This section of the document communicates product Errata for the Intel® NUC 9 Extreme Kit and the Intel® NUC 9 Pro Kit.

Errata are design defects or deviations from current published specifications for a given product. Published errata may or may not be corrected. Hardware and software designed to be used with any given processor stepping must assume that all errata documented for that process stepping are present on all devices.

There are no characterized errata at this time.

5 Regulatory Compliance and Battery Disposal Information

5.1 Regulatory Compliance

This section contains the following regulatory compliance information for Intel NUC Board NUC 9 Extreme/Pro Kit with regulatory model NUC9QN:

- Safety standards
- European Union Declaration of Conformity statement
- Electromagnetic Compatibility (EMC) standards
- Product Ecology statements
- Regulatory Compliance Marks

5.1.1 Safety Standards

Intel NUC 9 Extreme/Pro Kit with regulatory model NUC9QN complies with the safety standards stated in Table 16 when correctly installed in a compatible host system.

Table 16. Safety Standards

Standard	Title
CSA/UL 60950-1	Information Technology Equipment – Safety - Part 1: General Requirements (USA and Canada)
EN 60950-1	Information Technology Equipment – Safety - Part 1: General Requirements (European Union)
IEC 60950-1	Information Technology Equipment – Safety - Part 1: General Requirements (International)
EN62368-1	Information Technology Equipment – Safety - Part 1: General Requirements (European Union)

5.1.2 European Union Declaration of Conformity Statement

We, Intel Corporation, declare under our sole responsibility that the products Intel® NUC 9 Extreme/Pro Kit with regulatory model NUC9QN is in conformity with all applicable essential requirements necessary for CE marking, following the provisions of the European Council Directive 2004/108/EC (EMC Directive), 2006/95/EC (Low Voltage Directive), and 2011/65/EU (ROHS Directive).

The product is properly CE marked demonstrating this conformity and is for distribution within all member states of the EU with no restrictions.



This product follows the provisions of the European Directives 2004/108/EC, 2006/95/EC, and 2011/65/EU.

Čeština Tento výrobek odpovídá požadavkům evropských směrnic 2004/108/EC, 2006/95/EC a 2002/95/EC.

Dansk Dette produkt er i overensstemmelse med det europæiske direktiv 2004/108/EC, 2006/95/EC & 2002/95/EC.

Dutch Dit product is in navolging van de bepalingen van Europees Directief 2004/108/EC, 2006/95/EC & 2002/95/EC.

Eesti Antud toode vastab Euroopa direktiivides 2004/108/EC, ja 2006/95/EC ja 2002/95/EC kehtestatud nõuetele.

Suomi Tämä tuote noudattaa EU-direktiivin 2004/108/EC, 2006/95/EC & 2002/95/EC määräyksiä.

Français Ce produit est conforme aux exigences de la Directive Européenne 2004/108/EC, 2006/95/EC & 2002/95/EC.

Deutsch Dieses Produkt entspricht den Bestimmungen der Europäischen Richtlinie 2004/108/EC, 2006/95/EC & 2002/95/EC.

Ελληνικά Το παρόν προϊόν ακολουθεί τις διατάξεις των Ευρωπαϊκών Οδηγιών 2004/108/EC, 2006/95/EC και 2002/95/EC.

Magyar E termék megfelel a 2004/108/EC, 2006/95/EC és 2002/95/EC Európai Irányelv előírásainak.

Icelandic Þessi vara stenst reglugerð Evrópska Efnahags Bandalagsins númer 2004/108/EC, 2006/95/EC, & 2002/95/EC.

Italiano Questo prodotto è conforme alla Direttiva Europea 2004/108/EC, 2006/95/EC & 2002/95/EC.

Latviešu Šis produkts atbilst Eiropas Direktīvu 2004/108/EC, 2006/95/EC un 2002/95/EC noteikumiem.

Lietuvių Šis produktas atitinka Europos direktyvų 2004/108/EC, 2006/95/EC, ir 2002/95/EC nuostatas.

Malti Dan il-prodott hu konformi mal-provvedimenti tad-Direttivi Ewropej 2004/108/EC, 2006/95/EC u 2002/95/EC.

Norsk Dette produktet er i henhold til bestemmelsene i det europeiske direktivet 2004/108/EC, 2006/95/EC & 2002/95/EC.

Polski Niniejszy produkt jest zgodny z postanowieniami Dyrektyw Unii Europejskiej 2004/108/EC, 206/95/EC i 2002/95/EC.

Portuguese Este produto cumpre com as normas da Diretiva Europeia 2004/108/EC, 2006/95/EC & 2002/95/EC.

Español Este producto cumple con las normas del Directivo Europeo 2004/108/EC, 2006/95/EC & 2002/95/EC.

Slovensky Tento produkt je v súlade s ustanoveniami európskych direktív 2004/108/EC, 2006/95/EC a 2002/95/EC.

Slovenščina Izdelek je skladen z določbami evropskih direktiv 2004/108/EC, 2006/95/EC in 2002/95/EC.

Svenska Denna produkt har tillverkats i enlighet med EG-direktiv 2004/108/EC, 2006/95/EC & 2002/95/EC.

Türkçe Bu ürün, Avrupa Birliği'nin 2004/108/EC, 2006/95/EC ve 2002/95/EC yönergelerine uyur.

5.1.3 EMC Regulations

Intel NUC 9 Extreme/Pro Kit with regulatory model NUC9QN complies with the EMC regulations stated in Table 17 when correctly installed in a compatible host system.

Table 17. EMC Regulations

Regulation	Title
FCC 47 CFR Part 15, Subpart B	Title 47 of the Code of Federal Regulations, Part 15, Subpart B, Radio Frequency Devices. (USA)
ICES-003	Interference-Causing Equipment Standard, Digital Apparatus. (Canada)
EN55032	Limits and methods of measurement of Radio Interference Characteristics of Information Technology Equipment. (European Union)
EN55024	Information Technology Equipment – Immunity Characteristics Limits and methods of measurement. (European Union)
EN55022	Australian Communications Authority, Standard for Electromagnetic Compatibility. (Australia and New Zealand)
CISPR 32	Limits and methods of measurement of Radio Disturbance Characteristics of Information Technology Equipment. (International)
CISPR 24	Information Technology Equipment – Immunity Characteristics – Limits and Methods of Measurement. (International)
VCCI-CISPR 32	Voluntary Control for Interference by Information Technology Equipment. (Japan)
KN-35, KN-24	Korean Communications Commission – Framework Act on Telecommunications and Radio Waves Act (South Korea)
CNS 13438	Bureau of Standards, Metrology, and Inspection (Taiwan)

FCC Declaration of Conformity

This device complies with Part 15 of the FCC Rules. Operation is subject to the following two conditions: (1) this device may not cause harmful interference, and (2) this device must accept any interference received, including interference that may cause undesired operation.

For questions related to the EMC performance of this product, contact:

Intel Corporation, 5200 N.E. Elam Young Parkway, Hillsboro, OR 97124
1-800-628-8686

This equipment has been tested and found to comply with the limits for a Class B digital device, pursuant to Part 15 of the FCC Rules. These limits are designed to provide reasonable protection against harmful interference in a residential installation. This equipment generates, uses, and can radiate radio frequency energy and, if not installed and used in accordance with the instructions, may cause harmful interference to radio communications. However, there is no guarantee that interference will not occur in a particular installation. If this equipment does cause harmful interference to radio or television reception, which can be determined by turning the equipment off and on, the user is encouraged to try to correct the interference by one or more of the following measures:

- Reorient or relocate the receiving antenna.
- Increase the separation between the equipment and the receiver.
- Connect the equipment to an outlet on a circuit other than the one to which the receiver is connected.
- Consult the dealer or an experienced radio/TV technician for help.

Any changes or modifications to the equipment not expressly approved by Intel Corporation could void the user's authority to operate the equipment.

Tested to comply with FCC standards for home or office use.

Canadian Department of Communications Compliance Statement

This digital apparatus does not exceed the Class B limits for radio noise emissions from digital apparatus set out in the Radio Interference Regulations of the Canadian Department of Communications.

Le présent appareil numérique n'émet pas de bruits radioélectriques dépassant les limites applicables aux appareils numériques de la classe B prescrites dans le Règlement sur le brouillage radioélectrique édicté par le ministère des Communications du Canada.

Japan VCCI Statement

Japan VCCI Statement translation: This is a Class B product based on the standard of the Voluntary Control Council for Interference from Information Technology Equipment (VCCI). If this is used near a radio or television receiver in a domestic environment, it may cause radio interference. Install and use the equipment according to the instruction manual.

この装置は、情報処理装置等電波障害自主規制協議会（VCCI）の基準に基づくクラスB情報技術装置です。この装置は、家庭環境で使用することを目的としていますが、この装置がラジオやテレビジョン受信機に近接して使用されると、受信障害を引き起こすことがあります。
取扱説明書に従って正しい取り扱いをして下さい。

Korea Class B Statement

Korea Class B Statement translation: This equipment is for home use, and has acquired electromagnetic conformity registration, so it can be used not only in residential areas, but also other areas.

이 기기는 가정용(B급) 전자파적합기기로서 주로 가정에서 사용하는 것을 목적으로 하며, 모든 지역에서 사용할 수 있습니다.

5.1.4 e-Standby and ErP Compliance

Intel NUC 9 Extreme/Pro Kit with regulatory model NUC9QN meets the following program requirements in an adequate system configuration, including appropriate selection of an efficient power supply:

- EPEAT*
- Korea e-Standby
- European Union Energy-related Products Directive 2013 (ErP) Lot 6 and ErP Lot 3

For information about

Electronic Product Environmental Assessment Tool (EPEAT)

Refer to

<http://www.epeat.net/>

Korea e-Standby Program

http://www.kemco.or.kr/new_eng/pg02/pg02_100300.asp









European Union Energy-related Products Directive 2009 (ErP)

http://ec.europa.eu/enterprise/policies/sustainable-business/sustainable-product-policy/ecodesign/index_en.htm

5.1.5 Regulatory Compliance Marks (Board Level)

Intel NUC 9 Extreme/Pro Kit with regulatory model NUC9QN has the regulatory compliance marks shown in Table 18.

Table 18. Regulatory Compliance Marks

Description	Mark
UL joint US/Canada Recognized Component mark. Includes adjacent UL file number for Intel NUC: E210882.	
FCC Declaration of Conformity logo mark for Class B equipment.	
CE mark. Declaring compliance to the European Union (EU) EMC directive, Low Voltage directive, and RoHS directive. For CE Mark-Related Questions: Intel Corporation Attn: Corporate Quality 2200 Mission College Blvd. Santa Clara, CA 95054-1549 USA	
Australian Communications Authority (ACA) and New Zealand Radio Spectrum Management (NZ RSM) C-tick mark. Includes adjacent Intel supplier code number, N-232.	
Japan VCCI (Voluntary Control Council for Interference) mark.	
Korea Certification mark. Includes an adjacent MSIP (Ministry of Science, ICT & Future Planning) certification number: MSIP-REM-CPU-NUC5i5MYBE	
Taiwan BSMI (Bureau of Standards, Metrology and Inspections) mark. Includes adjacent Intel company number, D33025.	 D33025 RoHS
Printed wiring board manufacturer's recognition mark. Consists of a unique UL recognized manufacturer's logo, along with a flammability rating (solder side). Dependent upon the rating material.	V-0 or V-1
China RoHS/Environmentally Friendly Use Period Logo: This is an example of the symbol used on Intel NUC and associated collateral. The color of the mark may vary depending upon the application. The Environmental Friendly Usage Period (EFUP) for Intel NUC has been determined to be 10 years.	

5.2 Battery Disposal Information



CAUTION

Risk of explosion if the battery is replaced with an incorrect type. Batteries should be recycled where possible. Disposal of used batteries must be in accordance with local environmental regulations.



PRÉCAUTION

Risque d'explosion si la pile usagée est remplacée par une pile de type incorrect. Les piles usagées doivent être recyclées dans la mesure du possible. La mise au rebut des piles usagées doit respecter les réglementations locales en vigueur en matière de protection de l'environnement.



FORHOLDSREGEL

Eksplodingsfare, hvis batteriet erstattes med et batteri af en forkert type. Batterier bør om muligt genbruges. Bortskaffelse af brugte batterier bør foregå i overensstemmelse med gældende miljølovgivning.



OBS!

Det kan oppstå eksplosjonsfare hvis batteriet skiftes ut med feil type. Brukte batterier bør kastes i henhold til gjeldende miljølovgivning.



VIKTIGT!

Risk för explosion om batteriet ersätts med felaktig batterityp. Batterier ska kasseras enligt de lokala miljövårdsbestämmelserna.



VARO

Räjähdysvaara, jos pariston tyyppi on väärä. Paristot on kierrätettävä, jos se on mahdollista. Käytetyt paristot on hävitettävä paikallisten ympäristömääräysten mukaisesti.



VORSICHT

Bei falschem Einsetzen einer neuen Batterie besteht Explosionsgefahr. Die Batterie darf nur durch denselben oder einen entsprechenden, vom Hersteller empfohlenen Batterietyp ersetzt werden. Entsorgen Sie verbrauchte Batterien den Anweisungen des Herstellers entsprechend.



AVVERTIMENTO

Esiste il pericolo di un esplosione se la pila non viene sostituita in modo corretto. Utilizzare solo pile uguali o di tipo equivalente a quelle consigliate dal produttore. Per disfarsi delle pile usate, seguire le istruzioni del produttore.



PRECAUCIÓN

Existe peligro de explosión si la pila no se cambia de forma adecuada. Utilice solamente pilas iguales o del mismo tipo que las recomendadas por el fabricante del equipo. Para deshacerse de las pilas usadas, siga igualmente las instrucciones del fabricante.



WAARSCHUWING

Er bestaat ontploffingsgevaar als de batterij wordt vervangen door een onjuist type batterij. Batterijen moeten zoveel mogelijk worden gerecycled. Houd u bij het weggoeien van gebruikte batterijen aan de plaatselijke milieuwetgeving.



ATENÇÃO

Haverá risco de explosão se a bateria for substituída por um tipo de bateria incorreto. As baterias devem ser recicladas nos locais apropriados. A eliminação de baterias usadas deve ser feita de acordo com as regulamentações ambientais da região.



AŠCIAROŽZNAŚĆ

Існуе рызыка выбуху, калі заменены акумулятар неправільнага тыпу. Акумулятары павінны, па магчымасці, перепрацоўвацца. Пазбаўляцца ад старых акумулятараў патрэбна згодна з мясцовым заканадаўствам па экалогіі.



UPOZORNĚNÍ

V případě výměny baterie za nesprávný druh může dojít k výbuchu. Je-li to možné, baterie by měly být recyklovány. Baterie je třeba zlikvidovat v souladu s místními předpisy o životním prostředí.



Προσοχή

Υπάρχει κίνδυνος για έκρηξη σε περίπτωση που η μπαταρία αντικατασταθεί από μία λανθασμένου τύπου. Οι μπαταρίες θα πρέπει να ανακυκλώνονται όταν κάτι τέτοιο είναι δυνατό. Η απόρριψη των χρησιμοποιημένων μπαταριών πρέπει να γίνεται σύμφωνα με τους κατά τόπο περιβαλλοντικούς κανονισμούς.



VIGYÁZAT

Ha a telepet nem a megfelelő típusú telepre cseréli, az felrobbanhat. A telepeket lehetőség szerint újra kell hasznosítani. A használt telepeket a helyi környezetvédelmi előírásoknak megfelelően kell kiselejtezni.



注意

異なる種類の電池を使用すると、爆発の危険があります。リサイクルが可能な地域であれば、電池をリサイクルしてください。使用後の電池を破棄する際には、地域の環境規制に従ってください。



AWAS

Risiko letupan wujud jika bateri digantikan dengan jenis yang tidak betul. Bateri sepatutnya dikitar semula jika boleh. Pelupusan bateri terpakai mestilah mematuhi peraturan alam sekitar tempatan.



OSTRZEŻENIE

Istnieje niebezpieczeństwo wybuchu w przypadku zastosowania niewłaściwego typu baterii. Zużyte baterie należy w miarę możliwości utylizować zgodnie z odpowiednimi przepisami ochrony środowiska.



PRECAUȚIE

Risc de explozie, dacă bateria este înlocuită cu un tip de baterie necorespunzător. Bateriile trebuie reciclate, dacă este posibil. Depozitarea bateriilor uzate trebuie să respecte reglementările locale privind protecția mediului.



ВНИМАНИЕ

При использовании батареи несоответствующего типа существует риск ее взрыва. Батареи должны быть утилизированы по возможности. Утилизация батарей должна проводиться по правилам, соответствующим местным требованиям.



UPOZORNENIE

Ak batériu vymeníte za nesprávny typ, hrozí nebezpečenstvo jej výbuchu. Batérie by sa mali podľa možnosti vždy recyklovať. Likvidácia použitých batérií sa musí vykonávať v súlade s miestnymi predpismi na ochranu životného prostredia.



POZOR

Zamenjava baterije z baterijo drugačnega tipa lahko povzroči eksplozijo. Če je mogoče, baterije reciklirajte. Rabljene baterije zavržite v skladu z lokalnimi okoljevarstvenimi predpisi.



คำเตือน

ระวังการระเบิดที่เกิดจากเปลี่ยนแบตเตอรี่ผิดประเภท หากเป็นไปได้ ควรนำแบตเตอรี่ไปรีไซเคิล การทิ้งแบตเตอรี่ใช้แล้วต้องเป็นไปตามกฎข้อบังคับด้านสิ่งแวดล้อมของท้องถิ่น.



UYARI

Yanlış türde pil takıldığında patlama riski vardır. Piller mümkün olduğunda geri dönüştürülmelidir. Kullanılmış piller, yerel çevre yasalarına uygun olarak atılmalıdır.



ОСТОРОГА

Використовуйте батареї правильного типу, інакше існуватиме ризик вибуху. Якщо можливо, використані батареї слід утилізувати. Утилізація використаних батарей має бути виконана згідно місцевих норм, що регулюють охорону довкілля.



UPOZORNĚNÍ

V případě výměny baterie za nesprávný druh může dojít k výbuchu. Je-li to možné, baterie by měly být recyklovány. Baterie je třeba zlikvidovat v souladu s místními předpisy o životním prostředí.



ETTEVAATUST

Kui patarei asendatakse uue ebasobivat tüüpi patareiga, võib tekkida plahvatusoht. Tühjad patareid tuleb võimaluse korral viia vastavasse kogumispunkti. Tühjade patareide äraviskamisel tuleb järgida kohalikke keskkonnakaitse alaseid reegleid.



FIGYELMEZTETÉS

Ha az elemet nem a megfelelő típusúra cseréli, felrobbanhat. Az elemeket lehetőség szerint újra kell hasznosítani. A használt elemeket a helyi környezetvédelmi előírásoknak megfelelően kell kiselejtezni.



UZMANĪBU

Pastāv eksplozijas risks, ja baterijas tiek nomainītas ar nepareiza veida baterijām. Ja iespējams, baterijas vajadzētu nodot attiecīgos pieņemšanas punktus. Bateriju izmešanai atkritumos jānotiek saskaņā ar vietējiem vides aizsardzības noteikumiem.



DĒMESIO

Naudojant netinkamo tipo baterijas įrenginys gali sprogti. Kai tik įmanoma, baterijas reikia naudoti pakartotinai. Panaudotas baterijas išmesti būtina pagal vietinius aplinkos apsaugos nuostatus.



ATTENZJONI

Riskju ta' splużjoni jekk il-batterija tinbidel b'tip ta' batterija mhux korrett. Il-batteriji għandhom jiġu riċiklati fejn hu possibbli. Ir-rimi ta' batteriji użati għandu jsir skond ir-regolamenti ambjentali lokali.



OSTRZEŻENIE

Ryzyko wybuchu w przypadku wymiany na baterie niewłaściwego typu. W miarę możliwości baterie należy poddać recyklingowi. Zużytych baterii należy pozbywać się zgodnie z lokalnie obowiązującymi przepisami w zakresie ochrony środowiska.