



*dirt rocket*™

**MX125**



## **OWNER'S MANUAL**

**Read and understand this entire manual before allowing child to use this product! For assistance contact Razor.  
DO NOT RETURN TO STORE.**

**NOTE: Manual illustrations are for demonstration purposes only.  
Illustrations may not reflect exact appearance of actual product.  
Specifications subject to change without notice.**

**Please have your product along with the 19 character product I.D. code with you  
before contacting Razor for warranty assistance and/or replacement parts.**

**Product I.D. Code: \_\_\_\_\_ - \_\_\_\_\_ - \_\_\_\_\_**

# CONTENTS

Safety Warnings.....	1-2	Usage .....	7
Before You Begin.....	3	Repair and Maintenance.....	7-10
Assembly and Set-up.....	4-5	Troubleshooting Guide .....	11
Charging the Battery.....	6	MX125 Parts .....	12
Pre-Ride Checklist.....	6	Warranty and Contact Information .....	15

# SAFETY WARNINGS

**⚠ WARNING:** Riding an electric product does present potential risks and caution is required. Like any riding product, the MX125 has inherent hazards associated with its use (for example, falling off or riding it into a hazardous situation). Like any riding product, the MX125 can and is intended to move and it is therefore, of course, possible to lose control or otherwise get into dangerous situations. Both children, and adults responsible for supervising them, must recognize that if such things occur, a rider can be seriously injured or die even when using safety equipment and other precautions. RIDE AT YOUR OWN RISK AND USE COMMON SENSE.

**⚠ WARNING: PARENTAL AND ADULT RESPONSIBILITY AND SUPERVISION IS NECESSARY:**

This manual contains important safety information. It is your responsibility to review this information and make sure that all riders understand all warnings, cautions, instructions and safety topics, and assure that young riders are able to safely and responsibly use these products. Razor recommends that you periodically review and reinforce the information in this manual with younger riders, and that you inspect and maintain your children's product to ensure their safety.

Because products, like the MX125, can and do present potential hazards plainly associated with their use, it is well recognized THE NEED FOR EXERCISE OF PARENTAL RESPONSIBILITY IN SELECTING RIDING PRODUCTS APPROPRIATE TO THE AGE OF A CHILD, OR PARENTAL SUPERVISION IN SITUATIONS IN WHICH CHILDREN OF VARIOUS AGES MAY HAVE ACCESS TO THE SAME RIDING PRODUCTS, IS IMPORTANT. Not every product is appropriate for every age or size of child, and different age recommendations are found within this category of product which are intended to reflect the nature of the hazards and the expected mental or physical ability, or both, of a child to cope with the hazards.

Razor recommends that children under the age of 7 not be permitted to use the MX125. This recommendation is based not just on age or weight or height – it reflects consideration of expected maturity and skills as well as physical size. The recommended rider age of 7 years or older for MX125 is only an estimate and can be affected by the rider's size, weight or skills – not every child 7 years old will be suited to the MX125.

**The recommended minimum rider age is 7 and older.** Any rider unable to fit comfortably on the electric product should not attempt to ride it.

**A parent's decision to allow his or her child to ride this product should be based on the child's maturity, skill and ability to follow rules. Razor emphasizes that adults are strongly advised not to disregard Razor's recommendations or permit younger children to ride the MX125.**

**Keep this product away from small children and remember that it is intended for use only by persons who are, at a minimum, completely comfortable and competent while operating the product.**

Persons with any mental or physical conditions that may make them susceptible to injury, impair their physical dexterity or mental capabilities to recognize, understand, and follow safety instructions and to be able to understand the hazards inherent in product use, should not use or be permitted to use products inappropriate for their abilities. Persons with heart conditions, head, back or neck ailments (or prior surgeries to these areas of the body), or pregnant women, should be cautioned not to operate such products.

**DO NOT EXCEED THE WEIGHT LIMIT OF 110 lb (50 kg). Rider weight does not necessarily mean a person's size is appropriate to fit or maintain control of the product.**

**CHECK AND MAINTAIN PRODUCT CONDITIONS**

Before use, check to confirm that any and all chain guards or other covers and guards are in place and in serviceable condition. Check that the brake is functioning properly, and that tires are inflated properly and have sufficient tread remaining. The product should be maintained and repaired in accordance with the manufacturer's specifications, using only the manufacturer's authorized replacement parts, and should not be modified from the manufacturer's original design and configuration.

**ACCEPTABLE RIDING PRACTICES AND CONDITIONS**

**Always check and obey any local laws or regulations, which may affect the locations where the electric product may be used. Keep safely away from cars and motor vehicle traffic at all times, and only use where allowed and with caution.**

Do not activate the speed control on the hand grip unless you are on the product and in a safe, outdoor environment suitable for riding.

The normal powered top speed of the MX125 will be approximately 8 mph (13 km/h), which can be affected by conditions, such as rider weight, inclines, tire inflation and battery charge level. Avoid excessive speeds that can be associated with downhill rides.

Maintain a hold on the handlebars at all times. Do not touch the brakes or motor on your product when in use or immediately after riding as these parts can become very hot.

Ride defensively. Watch out for potential obstacles that could catch your wheel or force you to swerve suddenly or lose control. Be careful to avoid pedestrians, skaters, skateboards, scooters, bikes, children or animals who may enter your path, and respect the rights and property of others.

The electric product is intended for use on flat, dry surfaces, such as pavement or level ground, without loose debris, such as sand, leaves, rocks or gravel. Wet, slick, bumpy, uneven or rough surfaces may impair traction and contribute to possible accidents. Do not ride your electric product in mud, ice, puddles or water. Watch out for potential obstacles that could catch your wheel or force you to swerve suddenly or lose control. Avoid sharp bumps, drainage grates, and sudden surface changes.

Do not attempt or do stunts or tricks on your electric product. The MX125 is not made to withstand abuse from misuse, such as jumping, curb grinding or any other type of stunts. Racing, stunt riding, or other maneuvers also enhance risk of loss of control, or may cause uncontrolled rider actions or reactions.

Never allow more than one person at a time to ride the electric product.

Do not ride at night or when visibility is limited.

Never use near steps or swimming pools.

Do not allow hands, feet, hair, body parts, clothing, or similar articles to come in contact with moving parts, wheels, drivetrain, or chain while the motor is running.

Never use headphones, a cell phone or text when riding.

Never hitch a ride with a vehicle.

# SAFETY WARNINGS

Do not ride your electric product in wet or icy weather and never immerse the product in water, as the electrical and drive components could be damaged by water or create other possibly unsafe conditions. Never risk damaging surfaces, such as carpet or flooring, by use of an electric product indoors.

## **PROPER RIDING ATTIRE**

Always wear proper protective equipment, such as an approved safety helmet (with chin strap securely buckled), elbow pads and kneepads. A helmet may be legally required by local law or regulation in your area. A long-sleeved shirt, long pants, and gloves are recommended. Always wear athletic shoes (lace-up shoes with rubber soles) and keep shoelaces tied and out of the way of the wheels, motor and drive system. Never ride barefooted or in sandals.

## **USING THE CHARGER**

The charger supplied with the electric product should be regularly examined for damage to the cord, plug, enclosure and other parts. In the event of such damage, the product must not be charged until the charger has been repaired or replaced.

Use only with the recommended charger.

Use caution when charging.

The charger is not a toy. Charger should be operated by an adult.

Do not operate charger near flammable materials.

Unplug charger and disconnect from product when not in use.

Always disconnect from the charger prior to wiping down and cleaning your electric product with damp cloth.

**FAILURE TO USE COMMON SENSE AND HEED THE ABOVE WARNINGS FURTHER INCREASES RISK OF SERIOUS INJURY. USE AT YOUR OWN RISK AND WITH APPROPRIATE AND SERIOUS ATTENTION TO SAFE OPERATION. USE CAUTION.**

# BEFORE YOU BEGIN

Remove contents from box. Remove the separators that protect the components from damage during shipping. Inspect the contents of the box for scratches in the paint, dents or kinked cables that may have occurred during shipping. Because the electric product is 95 percent assembled and packed at the factory, there should not be any problems, even if the box has a few scars or dents.

**MAKE SURE POWER SWITCH IS TURNED "OFF" BEFORE CONDUCTING ANY MAINTENANCE PROCEDURES.**

## Estimated Assembly and Set-Up Time

Razor recommends assembly by an adult.

Allow up to 15 minutes for assembly.

Allow up to 12 hours for initial charge (see page 6 for charging information).

Charger

**Note:** Charger design may vary from one shown

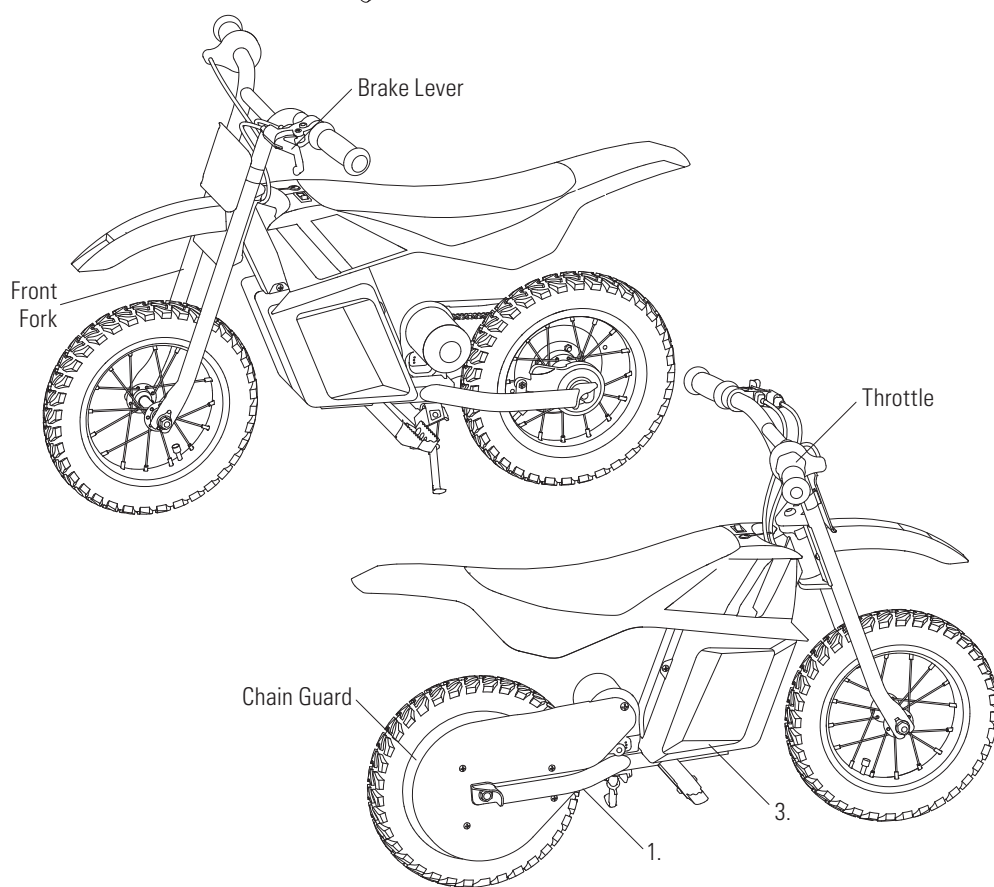
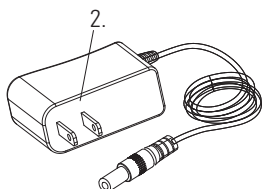

**WARNING: DO NOT USE NON-RAZOR PRODUCTS WITH YOUR RAZOR ELECTRIC PRODUCT.** The electric product has been built to certain Razor design specifications. The original equipment supplied at the time of sale was selected on the basis of its compatibility with the frame, fork and all other parts. Certain aftermarket products may not be compatible and will void your warranty.

### Product ID Locations: (See locations to the left)

1. Underneath Frame
2. Charger
3. Battery Cover
4. UPC Side of Box (not shown)

## Required Tools

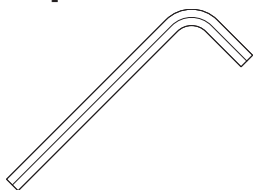

6 mm Allen Wrench (included)

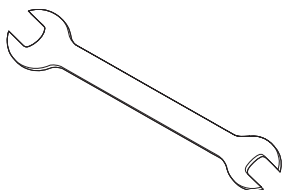

13 mm Wrench /  
14 mm Wrench (included)

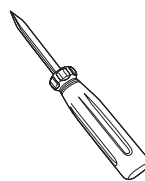

Phillips Screwdriver

### Plastic Bag Contents:

- Charger
- Tools
- Owner's Manual

**Need Help?** Visit our website for replacement parts, product support, a list of authorized service centers in the US and customer service contact information at [www.razor.com](http://www.razor.com). Please have the product I.D. code (located on the white label of your product) available for better assistance. Additional Customer Service contact information is listed at the back of this manual.

## ASSEMBLY AND SET-UP

### □ Attaching the Front Fork

**Tools Required:** 13 mm Wrench and 6 mm Allen Wrench

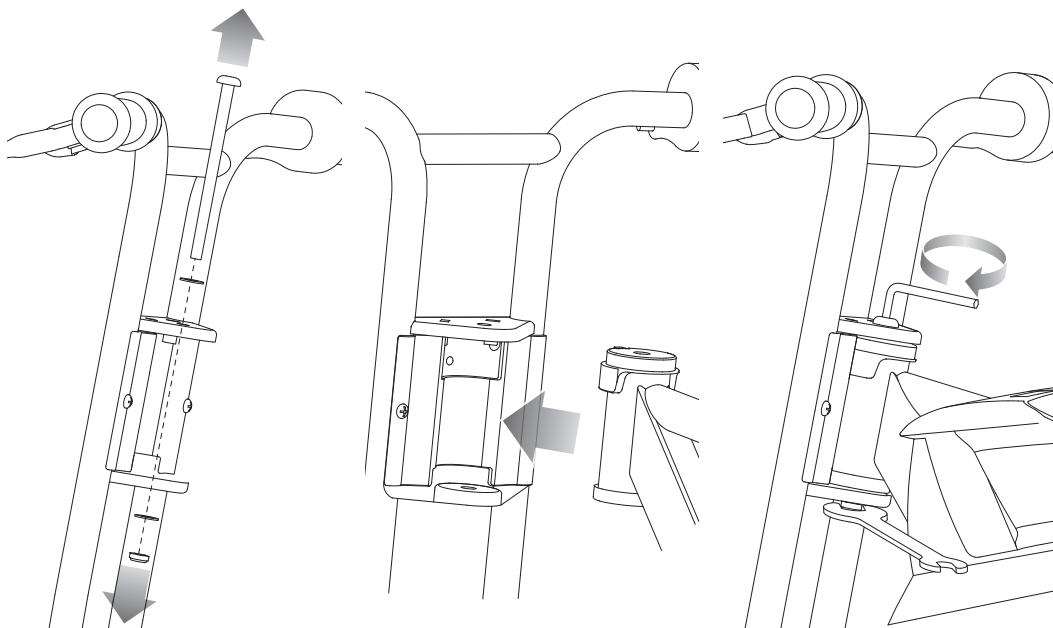

**1** Remove the steering bolt and locknut from the frame assembly with a 13 mm wrench and a 6 mm Allen wrench.

**2** Insert the front fork into the frame assembly. Be sure to properly align the slot on the headtube with the pin on the front fork as shown.

**3** Reinsert the steering bolt and secure with locknut using a 13 mm wrench and a 6 mm Allen wrench.

### ⚠ **WARNING:**

Failing to properly adjust and tighten the bolts that affix the handlebars can cause you to lose control and crash.

### □ Attaching the Front Wheel

**Tool Required:** 14 mm Wrench

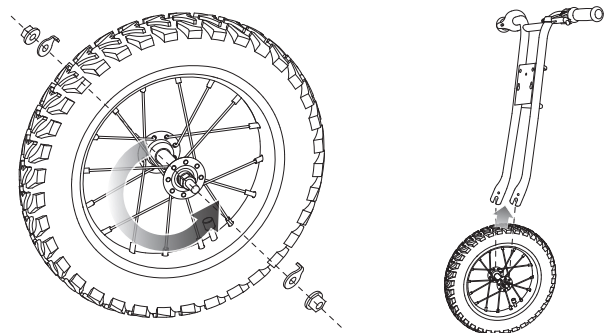

**1** Remove the locknuts on both sides of the front axle using a 14 mm wrench and remove the safety washers.

**2** Attach front wheel and reinstall safety washers and locknuts.



# ASSEMBLY AND SET-UP

## □ Attaching the Front Fender

**Tool Required:** Phillips screwdriver

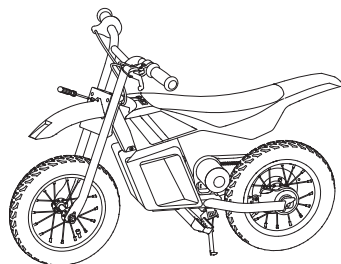
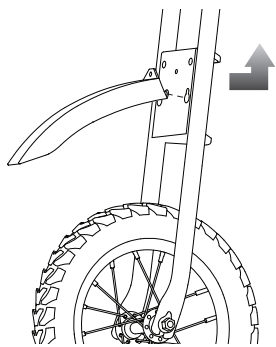

**1** Insert and align fender with the hole in the fork and insert the bolt.

**2** Tighten securely using a Phillips screwdriver.

## □ Attaching the Number Plate

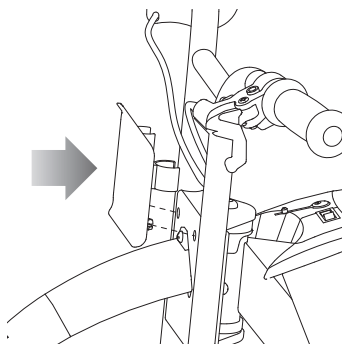

**1** Align the plastic tabs with the holes on the front fork and snap in place.

## □ Inflating the Tires

Tires are inflated when shipped, but they invariably lose some pressure between the point of manufacturing and your purchase. **Inflate the tires to the correct PSI before first time use.**

Lower air pressure can result in a shorter ride time. Periodically check front tire. Reinflate when needed.

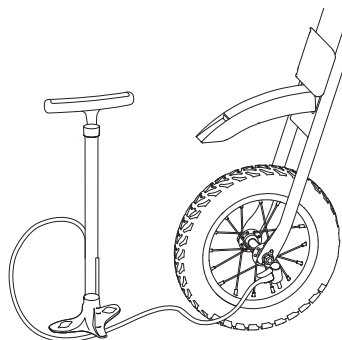

**1** Using a bicycle style pump equipped for a Schrader-type valve, inflate both tires to the PSI indicated on the sidewall of the tire.

### **⚠ WARNING:**

Do not use the electric product for the first time until you have inflated the tires to the correct PSI. Failure to do so may damage your motor bike and void your warranty.

### **⚠ WARNING:**

Do not overinflate, as this could damage the tire or wheel.

**Note:** The pressurized air supplies found at gasoline stations are designed to inflate high-volume automobile tires. If you decide to use such an air supply to inflate your tires, first make sure the pressure gauge is working, then use very short bursts to inflate to the correct PSI. If you inadvertently overinflate the tire, release the excess pressure immediately.

**Need Help?** Visit our website for replacement parts, product support, a list of authorized service centers in the US and customer service contact information at [www.razor.com](http://www.razor.com). Please have the product I.D. code (located on the white label of your product) available for better assistance. Additional Customer Service contact information is listed at the back of this manual.

## CHARGING THE BATTERY

Your electric product may not have a fully charged battery; therefore you must charge the battery prior to use.

- Initial charge time: 12 hours
- Recharge time: up to 6 hours, even if the light turns green. Recommended maximum charging time is 24 hours.
- Always charge the battery immediately after riding.
- Fully charge battery before storing for extended periods of time.
- Unplug charger from the wall outlet when not in use.
- Failure to recharge battery periodically may result in a battery that will not accept a charge.
- Make sure the electric product's power switch is turned **OFF** when unit is not in use. If the power

switch is left on for an extended period of time, the battery may reach a stage at which it will no longer hold a charge.

- To ensure long battery life, never store the product in freezing or below freezing temperatures! Freezing will permanently damage the battery.
- Run time: Up to 40 minutes of continuous ride time. Run time may vary depending on riding conditions, climate and/or proper maintenance.
- Constant stopping and starting may shorten ride time.
- Battery life can vary depending on proper maintenance and usage of the unit.

### ⚠ WARNING:

Use **ONLY** with the recommended charger. Batteries are only to be charged under adult supervision. The charger is not a toy. Always disconnect the charger before wiping down and/or cleaning the electric product with a damp cloth.

The charger supplied with the electric product should be regularly examined for damage to the cord, plug, enclosure and other parts. In the event of such damage, the electric product must not be charged until it has been repaired or replaced.

Chargers have built-in overcharge protection to prevent battery from being overcharged.

**Note:** If the charger gets warm during regular use, this is a normal response and is no cause for concern. If your charger does not get warm during use, it does not mean that it is not working properly.

Wall outlet - Green (stand by)  
Wall outlet and Unit - Red (Charging)  
Charging complete - Green (Charged)

**Note:** Continue charging unit even if light turns green prior to 6 hours.

**⚠ WARNING:** Failure to recharge the battery at least once a month may result in a battery that will no longer accept a charge.

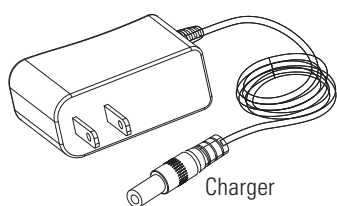

Charger

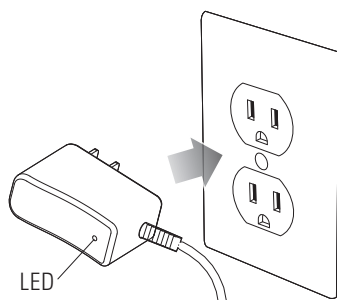

LED

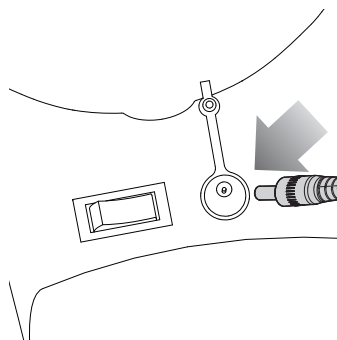

**Note:** Make sure power is turned **OFF** when unit is not in use. If the power switch is left on for an extended period of time, the battery may reach a stage at which it will no longer hold a charge.

**1** Plug the charger plug into a wall outlet. The light on the charger should be green.

**Note:** If green light (LED) does not turn on, try a different outlet.

**2** Make sure the power switch is in the **OFF** position. Plug the charger into the charger port on the product. The light on the charger should turn red during charging. The light will turn green when the charging is complete.

## PRE-RIDE CHECKLIST



### Brake

Check the brake for proper function. When you squeeze the lever, the brake should provide positive braking action. When you apply the brake with the speed control on, the brake cut-off switch will stop the motor.



### Tires

Periodically inspect the tires for excess wear and replace as needed. Regularly check the tire pressure and inflate as needed. If you get a flat tire, the inner tube can be patched or a new tube can be purchased from Razor or an authorized repair center.



### Frame, Fork and Handlebars

Check for cracks or broken connections. Although broken frames are rare, it is possible for an aggressive rider to run into a curb or object and wreck, bend or break the frame. Get in the habit of inspecting your product on a regular basis.



### Hardware/Loose Parts

Before every ride, check all parts, such as nuts, bolts, cables, fasteners, etc., to ensure they are secure and assembled correctly. There should not be any unusual rattles or sounds from loose parts or broken components. If the unit is damaged, do not ride. **Reference "Safety Warnings" on pages 1 and 2 of this manual.**



### Safety Gear

Always wear proper protective gear, such as an approved safety helmet. Elbow pads, kneepads, pants and long sleeves are recommended. Always wear closed toe shoes (lace-up with rubber soles) and keep shoelaces tied and out of the way of the wheels, motor and drive system. **NEVER RIDE BAREFOOTED OR IN SANDALS.**



### Laws and Regulations

Always check and obey any local laws or regulations.



### Insurance

Do not assume that your existing insurance policies necessarily provide coverage for electric product use. Check with your insurance company for information regarding insurance.

## USAGE

### □ Starting the Electric Product

Turn power switch to "ON."

Place both hands on the handlebars. Slowly push forward with one foot and apply the throttle.

**Note:** Keep both feet on the foot pegs when unit is in motion.

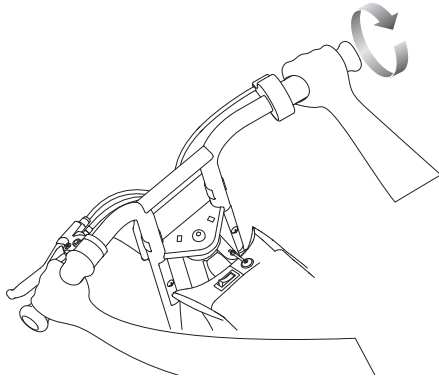

### □ Stopping the Electric Product

Release the throttle and apply the brake.

**Note:** When coming to a complete stop, place both feet on the ground to balance the unit.

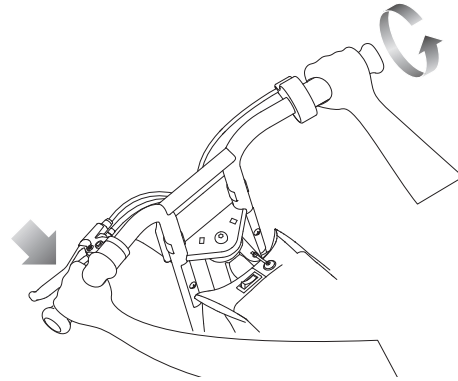

## REPAIR AND MAINTENANCE

**Turn power switch "OFF" before beginning repair or maintenance:**

- Read the instructions
- Remove charger plug
- Turn the power switch off
- Secure the unit under repair
- Exercise caution around exposed parts
- Contact Razor customer service if unsure about any repair or maintenance

### □ Testing the Brake

To use the brake, squeeze the lever to increase the pressure on the brake. The brake lever is fitted with a cable adjuster to compensate for cable stretch and/or to fine-tune the lever movement to engage the brake. If brake is not engaging properly, follow instructions for adjusting the brake outlined below.

### □ Adjusting the Brake

**Tool Required:** 10 mm Wrench

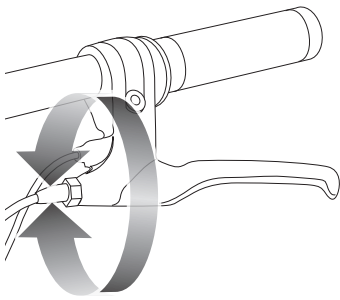

**1** To adjust the tension, thread the brake lever adjuster in or out 1/4 to 1/2 turn until the desired brake adjustment is attained. Most adjustments are complete at this step. If brake still needs further adjustment, proceed to step 2.

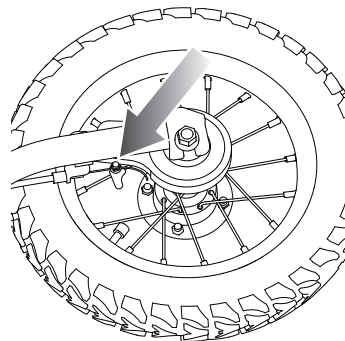

**2** If the brake has too much slack, use a 10 mm wrench to loosen the brake anchor cable for additional adjustment and retighten.

### ⚠ WARNING:

The brake is capable of causing the electric product to skid the tire, throwing an unsuspecting rider. Practice in an open area free from obstacles until you are familiar with the brake function. Avoid skidding to a stop as this can cause you to lose control or damage the rear tire.

**Note:** The brake lever contains a safety switch to cut power to the motor when the brake is applied. In an emergency, applying the brake will always stop the product from moving. Do not disable or replace this lever with anything other than a genuine Razor replacement part.

**Need Help?** Visit our website for replacement parts, product support, a list of authorized service centers in the US and customer service contact information at [www.razor.com](http://www.razor.com). Please have the product I.D. code (located on the white label of your product) available for better assistance. Additional Customer Service contact information is listed at the back of this manual.



# REPAIR AND MAINTENANCE

## Chain and Rear Wheel Replacement

Tools Required: Phillips Screwdriver, 10 mm Wrench, 8 mm Wrench, and 4 mm Allen Wrench

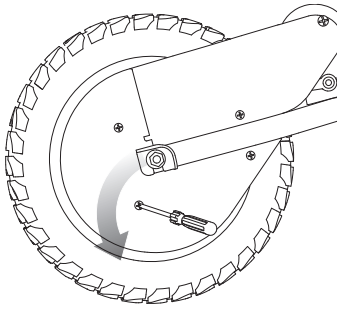

**1** Using a Phillips screwdriver loosen the screws on chain guard and remove the chain guard.

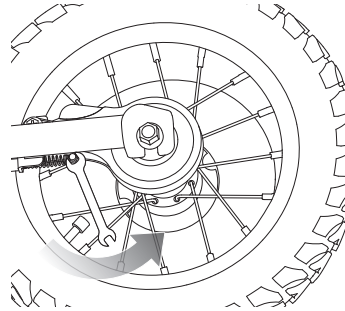

**2** With a 10 mm wrench, loosen the brake cable anchor bolt and disconnect the cable.

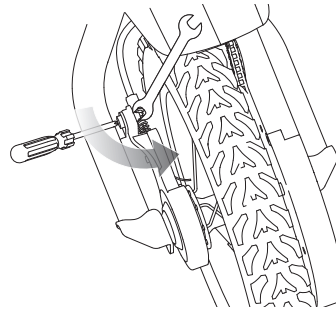

**3** With a Phillips screwdriver and 8 mm wrench remove the cable guide bracket from the frame and brake plate. Keep the spacer and washers together.

Note the hardware sequence (from outside toward the center).

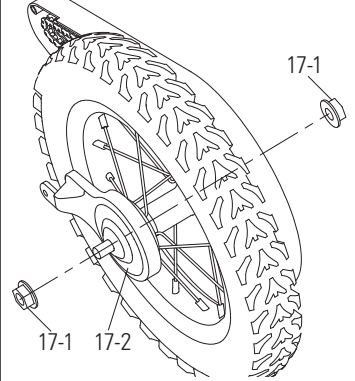

**Left Side (Brake)**  
17-1 15 mm Flange Locknut

**Frame**  
17-2 Brake Plate

**Right Side (Throttle)**  
17-1 15 mm Flange Locknut

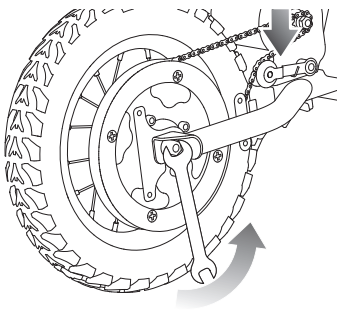

**4** With two (2) 15 mm wrenches, loosen the locknuts. Push the chain tensioner down to loosen the chain and remove wheel.

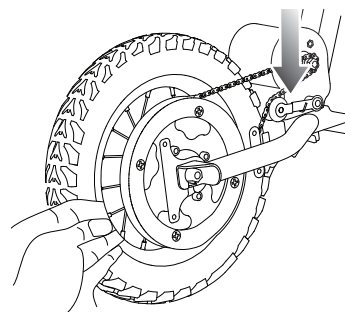

**5** Install the chain onto the rear wheel sprocket. Slip wheel axle into the frame slots. Push the chain tensioner down to create slack in chain. Hand tighten rear axle locknuts.

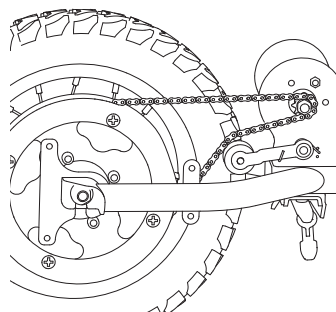

**6** Verify chain is properly installed on each sprocket and tensioner is correctly positioned at the bottom of the chain.

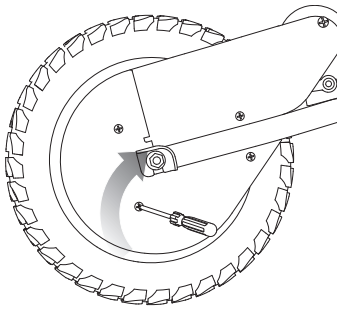

**7** Using a Phillips screwdriver, screw chain guard back in place.

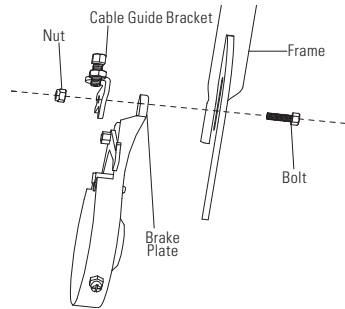

**8** Install the cable guide bracket to the frame and brake plate using bolt, washers, and nut. Do not tighten.

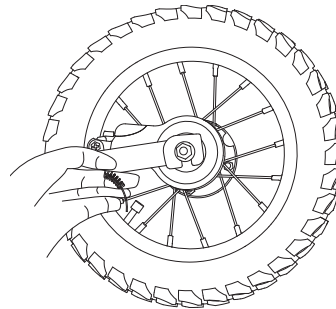

**9** Thread the brake cable through the brake adjuster barrel, through the large spring, and into the small hole in the side of the anchor bolt. Position the cable to the original location (as indicated by the slight cable kink) and tighten securely.

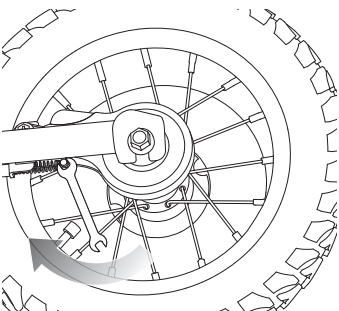

**10** Tighten the cable guide bracket bolt. Tighten the locknuts on the rear axle. Test the brake to verify proper function before riding. Readjust as needed.

## REPAIR AND MAINTENANCE

### □ Front Wheel Replacement

**Tools Required:** Phillips Screwdriver and 14 mm Wrench

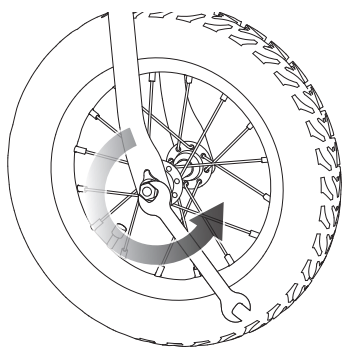

**1** Remove the locknuts on both sides of the front axle using a 14 mm wrench and remove the safety washers.

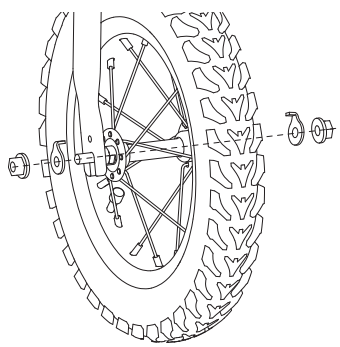

**2** Remove front wheel and install replacement wheel.

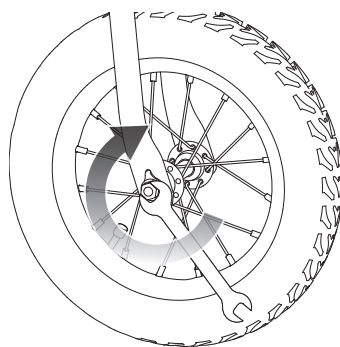

**3** Replace the safety washers and tighten the locknuts on both sides of the front axle using a 14 mm wrench.

## REPAIR AND MAINTENANCE

### Battery Care and Disposal

Do not store in freezing or below freezing temperatures. To properly maintain your battery and ensure maximum battery life, carefully read the "Charging the Battery" section on page 6 of this owner's manual.



CONTAINS SEALED NON-SPILLABLE LEAD-ACID BATTERY. BATTERY MUST BE RECYCLED.

**Disposal:** Your Razor product uses a sealed lead-acid battery which must be recycled or disposed of in an environmentally safe manner. Do not dispose of a lead-acid battery in a fire. The battery may explode or leak. Do not dispose of a lead-acid battery in your regular household trash. The incineration, land filling or mixing of sealed lead-acid batteries with household trash is prohibited by law in most areas. Return exhausted batteries to a federal or state approved lead-acid battery recycler or a local seller of automotive batteries. If you live in Florida or Minnesota, it is prohibited by law to throw away lead-acid batteries in the municipal waste stream.

### Charger

The charger supplied with the product should be regularly examined for damage to the cord, plug, enclosure and other parts and in the event of such damage, the product must not be charged until it has been repaired or replaced.

Use ONLY with the recommended charger.

### Wheels

Wheels and drive system are subject to normal wear and tear. It is the responsibility of the user to periodically inspect wheels for excess wear and adjust and replace drive train components as required.

### Replacement Parts

The most frequently requested replacement parts are available for purchase at some Razor retail partners. For the complete selection of replacement parts visit [www.razor.com/shop](http://www.razor.com/shop).

### Authorized Service Centers

For a list of authorized Razor repair centers:

- Check online at [www.razor.com](http://www.razor.com).
- Additional Customer Service contact information is listed on the back of this manual.



#### **In the US and Canada only:**

For more information regarding recycling of rechargeable batteries, call toll free 1-800-822-8837, or visit <http://www.call2recycle.org>

**⚠ WARNING:** If a battery leak develops, avoid contact with the leaking acid and place the damaged battery in a plastic bag. Refer to the disposal instructions at left. If acid comes into contact with skin or eyes, flush with cool water for at least 15 minutes and contact a physician.

**⚠ WARNING:** Battery posts, terminals and related accessories contain lead and lead compounds.

**Wash your hands after handling.**

# TROUBLESHOOTING GUIDE

\*Product(s) should be turned **OFF** and fully charged prior to doing any Troubleshooting.

**NOTE:** All troubleshooting steps should be performed by an adult only.

<b>Problem</b>	<b>Possible Cause</b>	<b>Solution</b>
Electric product does not run	Undercharged battery	Charge the battery. A new battery should have been charged for at least 12 hours before using the electric product for the first time and up to 6 hours after each subsequent use.  Check all connectors. Make sure the charger connector is tightly plugged into the charging port, and that the charger is plugged into the wall.  Make sure power flow to the wall outlet is on.
	Loose wires or connectors	Check all wires and connectors to make sure they are tight.  The fuse will burn out and automatically shut off the power if the motor is overloaded.
Electric product was running but suddenly stopped	Overload	Turn unit off then back on to reset the on/off/reset button.  Contact your local Razor authorized service center for diagnosis and repair.
Short run time (less than 15 minutes per charge)	Motor or electrical switch damage	Charge the battery. A new battery should have been charged for at least 12 hours before using the electric product for the first time and up to 6 hours after each subsequent use.
	Undercharged battery	Check all wires and connectors. Make sure the battery connector is tightly plugged into the charger connector, and that the charger is plugged into the wall.
	Tires are not properly inflated	The tires are inflated when shipped but they invariably will lose some pressure between the point of manufacturing and your purchase. Refer to instructions on page 5 of this manual to properly inflate tires.
	Battery is old and will not accept full charge	Even with proper care, a rechargeable battery does not last forever. Average battery life is 1 to 2 years depending on product use and conditions. Replace only with a Razor replacement battery.
	Brakes are not adjusted properly	Refer to brake adjustment instructions on page 7 of this manual.
Electric product runs sluggishly	Riding conditions are too stressful	Use only on solid, flat, clean and dry surfaces, such as pavement or level ground.
	Tires are not properly inflated	The tires are inflated when shipped, but they invariably will lose some pressure between the point of manufacturing and your purchase. Refer to instructions on page 5 of this manual to properly inflate tires.
	Electric product is overloaded	Make sure you do not overload the electric product by allowing more than one rider at one time, exceeding the maximum weight limit, going up too steep a hill or towing objects behind the product.
Sometimes the product doesn't run, but other times it does.	Loose wires or connectors	Check all wires around the motor and all connectors to make sure they are tight.
	Motor or electrical switch damage	Contact your local Razor authorized service center for diagnosis and repair.
Electric product does not stop when applying the brake	Brakes are not adjusted properly	Refer to instructions on page 7 of this manual to properly adjust brakes.
Electric product makes loud noises or grinding sounds	Chain is too dry.	Apply a lubricant such as 3 in 1™ or Tri-Flow™ to the chain.

For more troubleshooting tips, a list of available replacement parts or to locate an authorized Service Center in your area, visit our website at [www.razor.com](http://www.razor.com) or call toll free +1 866 467 2967 to speak to a live Customer Service Representative



# MX125 PARTS

Keep your MX125 running for years with genuine Razor parts. Visit our website or e-mail us for more information on spare part availability. (Specifications subject to change without notice.)

- |                                |                      |                                    |                           |
|--------------------------------|----------------------|------------------------------------|---------------------------|
| 1. Handlebar Grip (Right/Left) | 6. Front Fender      | 11. Battery (12V/5Ah)              | 16. Chain                 |
| 2. Throttle                    | 7. Control Module    | 12. Kickstand                      | 17. Chain Guard           |
| 2-1. Sleeve                    | 8. Front Wheel       | 13. Battery Retaining Strip        | 18. On/Off Switch         |
| 3. Front Fork                  | 9. Chain Tensioner   | 14. Battery Cover (Left and Right) | 19. Charger Port          |
| 4. Brake Lever Assembly        | 10. Motor (12V/100W) | 15. Rear Wheel                     | 20. Seat Fairing Complete |
| 5. Number Plate                |                      |                                    |                           |

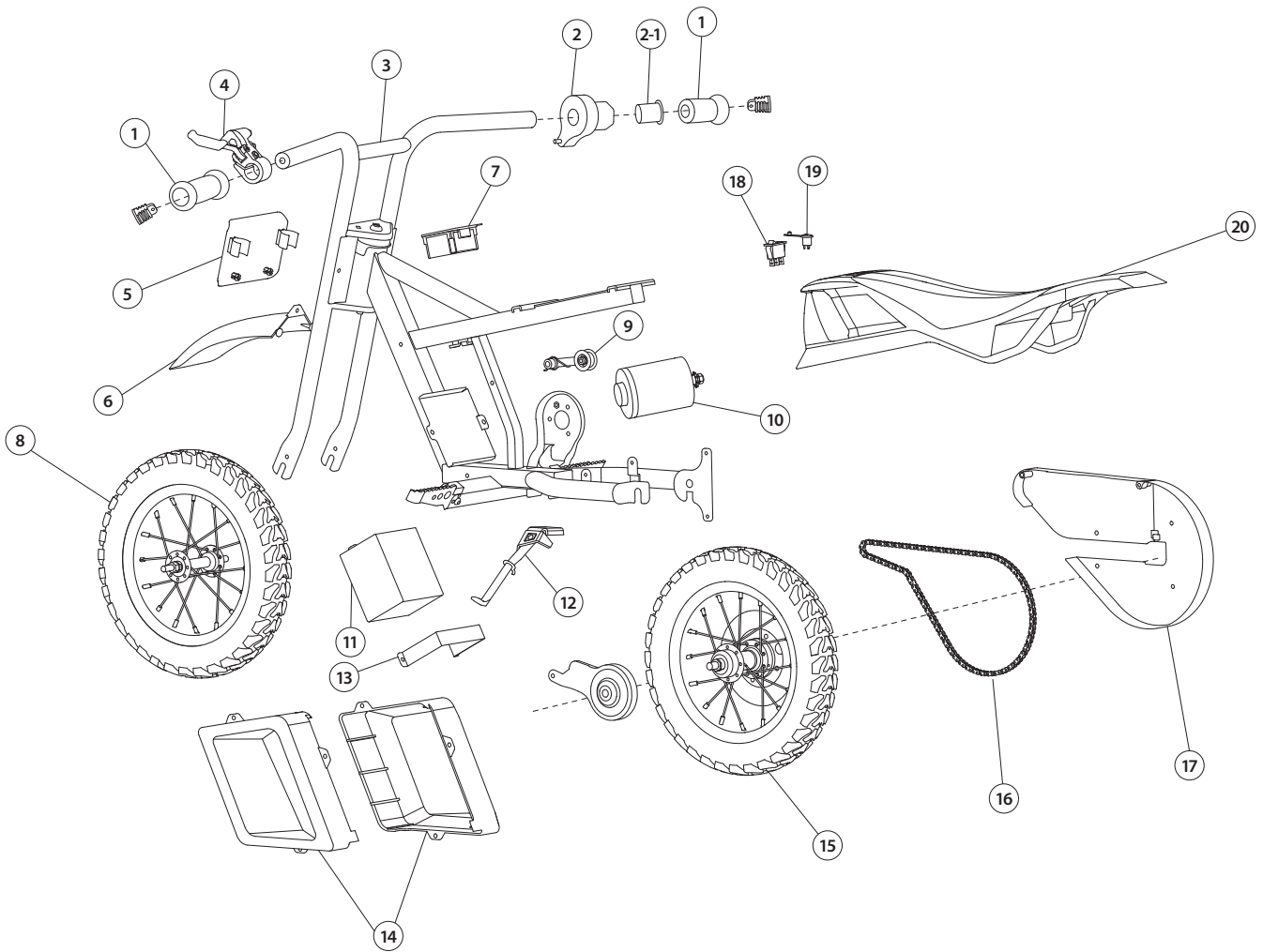

**Need Help?** Visit our website for replacement parts, product support, a list of authorized service centers in the US and customer service contact information at [www.razor.com](http://www.razor.com). Please have the product I.D. code (located on the white label of your product) available for better assistance. Additional Customer Service contact information is listed at the back of this manual.

**NOTICE: INSURANCE**  
**YOUR INSURANCE POLICIES MAY NOT PROVIDE COVERAGE FOR**  
**ACCIDENTS INVOLVING THE USE OF THIS SCOOTER/ELECTRIC**  
**RIDE-ON PRODUCT. TO DETERMINE IF COVERAGE IS PROVIDED,**  
**YOU SHOULD CONTACT YOUR INSURANCE COMPANY OR AGENT.**



## FCC COMPLIANCE

This device complies with Part 15 of the FCC Rules. Operation is subject to the following two conditions: (1) This device may not cause harmful interference, and (2) this device must accept any interference received, including interference that may cause undesired operation.

Note: This equipment has been tested and found to comply with the limits for a Class B digital device, pursuant to part 15 of the FCC Rules. These limits are designed to provide reasonable protection against harmful interference in a residential installation. This equipment generates, uses and can radiate radio frequency energy and, if not installed and used in accordance with the instructions, may cause harmful interference to radio communications. However, there is no guarantee that interference will not occur in a particular installation. If this equipment does cause harmful interference to radio or television reception, which can be determined by turning the equipment off and on, the user is encouraged to try to correct the interference by one or more of the following measures:

- Reorient or relocate the receiving antenna.
- Increase the separation between the equipment and receiver.
- Connect the equipment into an outlet on a circuit different from that to which the receiver is connected.
- Consult the dealer or an experienced radio/TV technician for help.

**! WARNING:** Changes or modifications to this unit not expressly approved by Razor USA, could void the user's authority to operate the equipment.

## WARRANTY

### Razor Limited Warranty

The manufacturer warrants this product to be free of manufacturing defects for a period of 90 days from date of purchase. This Limited Warranty does not cover normal wear and tear, tire, tube or cables, or any damage, failure or loss caused by improper assembly, maintenance, storage or use of the Razor MX125.

This Limited Warranty will be void if the product is ever:

- used in a manner other than for recreation or transportation;
- modified in any way;
- rented.

The manufacturer is not liable for incidental or consequential loss or damage due directly or indirectly to the use of this product.

Razor does not offer an extended warranty. If you have purchased an extended warranty, it must be honored by the store at which it was purchased.

For your records, save your original sales receipt with this manual and write the serial number below.

---

## CUSTOMER SERVICE CONTACT INFORMATION

**Need Help?** Visit our website for replacement parts, product support, a list of authorized service centers in the US and customer service contact information at [www.razor.com](http://www.razor.com). Please have the product I.D. code (located on the white label of your product) available for better assistance. Additional Customer Service contact information is listed below:

### AMERICAS

Razor USA LLC  
P.O. Box 3610  
Cerritos, CA 90703  
USA  
  
+1 866 467 2967  
Monday - Friday  
8:00 AM - 5:00 PM Pacific Time  
[customersupport@razorusa.com](mailto:customersupport@razorusa.com)

### EUROPE, MIDDLE EAST, AFRICA

Razor USA LLC (Europe)  
Handelsweg 2  
2742 RD Waddinxveen  
Netherlands  
  
+44 (0) 120 267 2702  
[info@razoreu.com](mailto:info@razoreu.com)

### ASIA

Razor USA LLC (Asia)  
P.O. Box 3610  
Cerritos, CA 90703  
USA  
  
+81 50 7579 6622  
[info@razor-asia.com](mailto:info@razor-asia.com)

### RAZOR UK

Unit 20  
Hartnoll Business Centre  
Post Hill, Tiverton  
Devon EX16 4NG  
UK  
  
+44 (0) 120 267 2702  
[info@razoreu.com](mailto:info@razoreu.com)

### DISTRIBUTED IN AUSTRALIA BY:

Funtastic Limited  
Suite 2.01, Level 2  
315 Ferntree Gully Road  
Mount Waverley Vic 3149,  
Australia  
  
+1 800 244 543  
[info@funtastic.com.au](mailto:info@funtastic.com.au)

### IMPORTED IN JAPAN BY B-PLUS ASIA CORP.

Razor USA LLC  
**THE RIBSTIK COMPANY**  
Kurokawa 3-1, Asaoku,  
Kawasaki, Kanagawa  
215-0035 JAPAN  
  
+81 (0) 44 328 9057 Tel  
+81 (0) 44 328 9067 Fax  
[info@razor-asia.com](mailto:info@razor-asia.com)

Printed in China for Razor USA LLC.

Copyright ©2003-2020 Razor USA, LLC. All rights reserved. Razor® and the Razor logo design are among the registered trademarks of Razor USA LLC in the United States and/or select foreign countries. Dirt Rocket and the Dirt Rocket MX125 logo design are trademarks of Razor USA LLC.

US\_200313