



US009871558B2

(12) **United States Patent**
Henry et al.

(10) **Patent No.:** **US 9,871,558 B2**
(45) **Date of Patent:** ***Jan. 16, 2018**

(54) **GUIDED-WAVE TRANSMISSION DEVICE AND METHODS FOR USE THEREWITH**

(71) Applicant: **AT&T INTELLECTUAL PROPERTY I, L.P.**, Atlanta, GA (US)

(72) Inventors: **Paul Shala Henry**, Holmdel, NJ (US); **Robert Bennett**, Southold, NY (US); **Irwin Gerszberg**, Kendall Park, NJ (US); **Farhad Barzegar**, Branchburg, NJ (US); **Donald J. Barnickel**, Flemington, NJ (US); **Thomas M. Willis, III**, Tinton Falls, NJ (US)

(73) Assignee: **AT&T INTELLECTUAL PROPERTY I, L.P.**, Atlanta, GA (US)

(*) Notice: Subject to any disclaimer, the term of this patent is extended or adjusted under 35 U.S.C. 154(b) by 0 days.

This patent is subject to a terminal disclaimer.

(21) Appl. No.: **15/396,991**

(22) Filed: **Jan. 3, 2017**

(65) **Prior Publication Data**

US 2017/0117938 A1 Apr. 27, 2017

Related U.S. Application Data

(63) Continuation of application No. 15/070,041, filed on Mar. 15, 2016, now Pat. No. 9,577,307, which is a (Continued)

(51) **Int. Cl.**
H04B 10/00 (2013.01)
H04B 3/52 (2006.01)
(Continued)

(52) **U.S. Cl.**
CPC **H04B 3/52** (2013.01); **H01P 3/10** (2013.01); **H01P 3/16** (2013.01); **H01P 5/00** (2013.01);
(Continued)

(58) **Field of Classification Search**
CPC . H04B 10/90; H04B 3/00; H04B 3/02; H04B 3/03; H04B 3/52; H04B 3/54; H04B 3/56
See application file for complete search history.

(56) **References Cited**

U.S. PATENT DOCUMENTS

395,814 A 1/1889 Henry et al.
529,290 A 11/1894 Harry et al.
(Continued)

FOREIGN PATENT DOCUMENTS

AU 565039 B2 9/1987
AU 582630 B2 4/1989
(Continued)

OTHER PUBLICATIONS

“AirCheck G2 Wireless Tester”, NetScout®, enterprise.netscout.com, Dec. 6, 2016 10 pages.

(Continued)

Primary Examiner — Daniel Dobson

(74) *Attorney, Agent, or Firm* — Ed Guntin; Bruce E. Stuckman

(57) **ABSTRACT**

Aspects of the subject disclosure may include, for example, a transmission device that includes a transmitter that generates a first electromagnetic wave to convey data, the first electromagnetic wave having at least one carrier frequency and corresponding wavelength. A coupler couples the first electromagnetic wave to a transmission medium having at least one inner portion surrounded by a dielectric material, the dielectric material having an outer surface and a corresponding circumference, wherein the coupling of the first electromagnetic wave to the transmission medium forms a second electromagnetic wave that is guided to propagate along the outer surface of the dielectric material via at least one guided-wave mode that can include an asymmetric mode, wherein the at least one carrier frequency is within a microwave or millimeter-wave frequency band and wherein

(Continued)

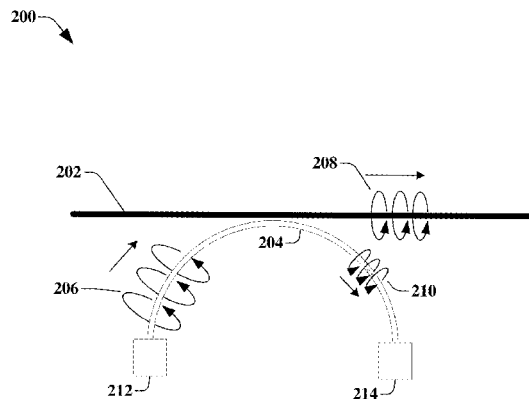

the at least one corresponding wavelength is less than the circumference of the transmission medium. Other embodiments are disclosed.

20 Claims, 20 Drawing Sheets

Related U.S. Application Data

continuation of application No. 14/519,566, filed on Oct. 21, 2014, now Pat. No. 9,577,306.

- (51) **Int. Cl.**
H04B 10/2575 (2013.01)
H04B 10/40 (2013.01)
H01P 3/16 (2006.01)
H01P 5/00 (2006.01)
H01P 3/10 (2006.01)
H01P 5/08 (2006.01)
H04J 14/00 (2006.01)
H04B 3/36 (2006.01)
- (52) **U.S. Cl.**
 CPC *H01P 5/087* (2013.01); *H04B 10/25752* (2013.01); *H04B 10/40* (2013.01); *H04B 3/36* (2013.01)

(56) **References Cited**

U.S. PATENT DOCUMENTS

1,721,785	A	7/1929	Meyer	2,691,766	A	10/1954	Clapp
1,798,613	A	3/1931	Manson et al.	2,706,279	A	4/1955	Aron
1,860,123	A	5/1932	Yagi	2,711,514	A	6/1955	Rines
2,058,611	A	10/1936	Merkle et al.	2,723,378	A	11/1955	Clavier et al.
2,106,770	A	2/1938	Southworth et al.	2,727,232	A	12/1955	Pryga
2,129,711	A	9/1938	Southworth	2,735,092	A	2/1956	Brown
2,129,714	A	9/1938	Southworth et al.	2,740,826	A	4/1956	Bondon
2,147,717	A	2/1939	Schelkunoff	2,745,101	A	5/1956	Marie
2,187,908	A	1/1940	McCreary	2,748,350	A	5/1956	Miller et al.
2,199,083	A	4/1940	Schelkunoff	2,749,545	A	6/1956	Kostriza
2,232,179	A	2/1941	King	2,754,513	A	7/1956	Goubau
2,283,935	A	5/1942	King	2,761,137	A	8/1956	Atta et al.
2,398,095	A	4/1946	Katzin	2,769,147	A	10/1956	Black et al.
2,402,622	A	6/1946	Hansen	2,769,148	A	10/1956	Clogston et al.
2,405,242	A	8/1946	Southworth et al.	2,794,959	A	6/1957	Fox
2,407,068	A	9/1946	Fiske et al.	2,805,415	A	9/1957	Berkowitz
2,407,069	A	9/1946	Fiske	2,806,177	A	9/1957	Haefl et al.
2,410,113	A	10/1946	Turner, Jr.	2,806,972	A	9/1957	Sensiper
2,411,338	A	11/1946	Roberts	2,810,111	A	10/1957	Cohn
2,415,089	A	2/1947	Feldman et al.	2,819,451	A	1/1958	Sims et al.
2,415,807	A	2/1947	Barrow et al.	2,820,083	A	1/1958	Hendrix
2,419,205	A	4/1947	Feldman et al.	2,825,060	A	2/1958	Ruze et al.
2,420,007	A	5/1947	Olden	2,835,871	A	5/1958	Raabe
2,422,058	A	6/1947	Whinnery	2,851,686	A	9/1958	Hagaman et al.
2,432,134	A	12/1947	Bagnall	2,867,776	A	1/1959	Wilkinson, Jr.
2,461,005	A	2/1949	Southworth	2,883,135	A	4/1959	Smalley et al.
2,471,021	A	5/1949	Bradley	2,883,136	A	4/1959	Smalley et al.
2,488,400	A	11/1949	Harder	2,900,558	A	8/1959	Watkins et al.
2,513,205	A	6/1950	Roberts et al.	2,910,261	A	10/1959	Ward et al.
2,514,679	A	7/1950	Southworth	2,912,695	A	11/1959	Cutler
2,519,603	A	8/1950	Reber	2,914,741	A	11/1959	Unger
2,540,839	A	2/1951	Southworth	2,915,270	A	12/1959	Gladsden et al.
2,541,843	A	2/1951	Tiley et al.	2,921,277	A	1/1960	Goubau
2,542,980	A	2/1951	Barrow	2,925,458	A	2/1960	Lester et al.
2,557,110	A	6/1951	Jaynes	2,933,701	A	4/1960	Lancot et al.
2,562,281	A	7/1951	Mumford	2,946,970	A	7/1960	Hafner et al.
2,596,190	A	5/1952	Wiley	2,949,589	A	8/1960	Hafner
2,599,864	A	6/1952	Robertson-Shersby-Ha et al.	2,960,670	A	11/1960	Marcatili et al.
2,659,817	A	11/1953	Cutler et al.	2,970,800	A	2/1961	Smalley et al.
2,667,578	A	1/1954	Carlson et al.	2,972,148	A	2/1961	Rupp et al.
2,677,055	A	4/1954	Allen	2,974,297	A	3/1961	Ros
2,685,068	A	7/1954	Goubau	2,981,949	A	4/1961	Elliott et al.
2,688,732	A	9/1954	Kock	2,990,151	A	6/1961	Phillips et al.
				2,993,205	A	7/1961	Cooper et al.
				3,016,520	A	1/1962	Chaimowicz et al.
				3,025,478	A	3/1962	Marcatili et al.
				3,028,565	A	4/1962	Walker et al.
				3,040,278	A	6/1962	Griemsmann et al.
				3,045,238	A	7/1962	Cheston et al.
				3,046,550	A	7/1962	Schlaud et al.
				3,047,822	A	7/1962	Lakatos et al.
				3,065,945	A	11/1962	Newsome et al.
				3,072,870	A	1/1963	Walker
				3,077,569	A	2/1963	Ikrath et al.
				3,096,462	A	7/1963	Feinstein et al.
				3,101,472	A	8/1963	Goubau
				3,109,175	A	10/1963	Lloyd
				3,129,356	A	4/1964	Phillips
				3,134,951	A	5/1964	Huber et al.
				3,146,297	A	8/1964	Hahne
				3,146,453	A	8/1964	Hagaman
				3,201,724	A	8/1965	Hafner
				3,205,462	A	9/1965	Meinke
				3,218,384	A	11/1965	Shaw
				3,219,954	A	11/1965	Rutelli
				3,234,559	A	2/1966	Bartholoma et al.
				3,255,454	A	6/1966	Carlton et al.
				3,296,364	A	1/1967	Jefferson et al.
				3,296,685	A	1/1967	Menahem et al.
				3,310,808	A	3/1967	Friis et al.
				3,316,344	A	4/1967	Toms et al.
				3,316,345	A	4/1967	Toms et al.
				3,318,561	A	5/1967	Robertson, Jr. et al.
				3,321,763	A	5/1967	Ikrath et al.
				3,329,958	A	7/1967	Anderson et al.
				3,351,947	A	11/1967	Hart et al.
				3,355,738	A	11/1967	Algeo et al.
				3,369,788	A	2/1968	Eisele
				3,389,394	A	6/1968	Lewis et al.

(56)

References Cited

U.S. PATENT DOCUMENTS

3,392,388	A	7/1968	Tsuneo et al.	3,956,751	A	5/1976	Herman
3,392,395	A	7/1968	Hannan	3,959,794	A	5/1976	Chrepta et al.
3,411,112	A	11/1968	Honig et al.	3,973,087	A	8/1976	Fong et al.
3,413,637	A	11/1968	Goebels, Jr. et al.	3,973,240	A	8/1976	Fong et al.
3,413,642	A	11/1968	Cook	3,976,358	A	8/1976	Thompson et al.
3,414,903	A	12/1968	Bartlett et al.	3,983,560	A	9/1976	MacDougall et al.
3,420,596	A	1/1969	Osterberg	4,010,799	A	3/1977	Kern et al.
3,427,573	A	2/1969	White et al.	4,012,743	A	3/1977	Maciejewski et al.
3,448,455	A	6/1969	Alfandari et al.	4,020,431	A	4/1977	Saunders et al.
3,453,617	A	7/1969	Brickey et al.	4,026,632	A	5/1977	Hill et al.
3,459,873	A	8/1969	Harris et al.	4,030,048	A	6/1977	Foldes et al.
3,465,346	A	9/1969	Patterson et al.	4,030,953	A	6/1977	Rutschow et al.
3,474,995	A	10/1969	Amidon et al.	4,031,536	A	6/1977	Alford et al.
3,482,251	A	12/1969	Bowes	4,035,054	A	7/1977	Lattanzi et al.
3,487,158	A	12/1969	Killian	4,047,180	A	9/1977	Kuo et al.
3,495,262	A	2/1970	Robert et al.	4,079,361	A	3/1978	Woode et al.
3,500,422	A	3/1970	Grady et al.	4,080,600	A	3/1978	Toman et al.
3,509,463	A	4/1970	Woodward et al.	4,099,184	A	7/1978	Rapshys et al.
3,522,560	A	8/1970	Hayany	4,114,121	A	9/1978	Barlow et al.
3,524,192	A	8/1970	Sakiotis et al.	4,115,782	A	9/1978	Han et al.
3,529,205	A	9/1970	Miller	4,123,759	A	10/1978	Hines et al.
3,530,481	A	9/1970	Tanaka et al.	4,125,768	A	11/1978	Jackson et al.
3,531,803	A	9/1970	Hudspeth et al.	4,129,872	A	12/1978	Toman et al.
3,536,800	A	10/1970	Hubbard	4,141,015	A	2/1979	Wong et al.
3,555,553	A	1/1971	Boyns	4,149,170	A	4/1979	Campbell et al.
3,557,341	A	1/1971	Sochilin et al.	4,155,108	A	5/1979	Tuttle et al.
3,566,317	A	2/1971	Hafner	4,156,241	A	5/1979	Mobley et al.
3,568,204	A	3/1971	Blaisdell	4,166,669	A	9/1979	Leonberger et al.
3,569,979	A	3/1971	Munk et al.	4,175,257	A	11/1979	Smith et al.
3,573,838	A	4/1971	Ajioka	4,188,595	A	2/1980	Cronson et al.
3,588,754	A	6/1971	Hafner	4,190,137	A	2/1980	Shimada et al.
3,588,755	A	6/1971	Kunio et al.	4,191,953	A	3/1980	Woode et al.
3,589,121	A	6/1971	Mulvey	4,195,302	A	3/1980	Leupelt et al.
3,594,494	A	7/1971	Ross et al.	4,210,357	A	7/1980	Adachi et al.
3,599,219	A	8/1971	Hansen et al.	4,216,449	A	8/1980	Kach
3,603,904	A	9/1971	Hafner	4,220,957	A	9/1980	Britt et al.
3,603,951	A	9/1971	Bracken et al.	4,231,042	A	10/1980	Turrin et al.
3,609,247	A	9/1971	Halstead	4,234,753	A	11/1980	Clutter
3,623,114	A	11/1971	Seaton	4,238,974	A	12/1980	Fawcett et al.
3,624,655	A	11/1971	Yamada et al.	4,246,584	A	1/1981	Noerpel et al.
3,638,224	A	1/1972	Bailey et al.	4,247,858	A	1/1981	Eichweber et al.
3,653,622	A	4/1972	Farmer	4,250,489	A	2/1981	Dudash et al.
3,666,902	A	5/1972	Owen et al.	4,268,804	A	5/1981	Spinner et al.
3,668,459	A	6/1972	Symons et al.	4,274,097	A	6/1981	Krall et al.
3,668,574	A	6/1972	Barlow	4,274,112	A	6/1981	Leysieffer et al.
3,672,202	A	6/1972	Barber et al.	4,278,955	A	7/1981	Lunden et al.
3,686,596	A	8/1972	Albee	4,293,833	A	10/1981	Popa et al.
3,693,922	A	9/1972	Gueguen	4,298,877	A	11/1981	Sletten et al.
3,699,574	A	10/1972	Plunk et al.	4,300,242	A	11/1981	Nava et al.
3,703,690	A	11/1972	Ravenscroft et al.	4,307,938	A	12/1981	Dyott et al.
3,704,001	A	11/1972	Sloop	4,316,646	A	2/1982	Siebens et al.
3,725,937	A	4/1973	Schreiber	4,319,074	A	3/1982	Yaste et al.
3,753,086	A	8/1973	Shoemaker et al.	4,329,690	A	5/1982	Parker et al.
3,760,127	A	9/1973	Grossi et al.	4,333,082	A	6/1982	Susman et al.
3,765,021	A	10/1973	Chiron et al.	4,335,613	A	6/1982	Luukkala et al.
3,772,528	A	11/1973	Anderson et al.	4,336,719	A	6/1982	Lynnworth
3,775,769	A	11/1973	Heeren et al.	4,345,256	A	8/1982	Rainwater et al.
3,787,872	A	1/1974	Kauffman	4,366,565	A	12/1982	Herskowitz
3,796,970	A	3/1974	Snell	4,367,446	A	1/1983	Hall et al.
3,806,931	A	4/1974	Wright	4,378,143	A	3/1983	Winzer et al.
3,833,909	A	9/1974	Schaufelberger	4,384,289	A	5/1983	Fernandes et al.
3,835,407	A	9/1974	Yariv et al.	4,398,058	A	8/1983	Gerth et al.
3,845,426	A	10/1974	Barlow	4,398,121	A	8/1983	Chodorow et al.
3,858,214	A	12/1974	Jones	4,413,263	A	11/1983	Amitay et al.
3,877,032	A	4/1975	Rosa	4,447,811	A	5/1984	Hamid et al.
3,888,446	A	6/1975	O'Brien et al.	4,458,250	A	7/1984	Bodnar et al.
3,896,380	A	7/1975	Martin	4,463,329	A	7/1984	Suzuki et al.
3,906,508	A	9/1975	Foldes	4,468,672	A	8/1984	Dragone et al.
3,911,415	A	10/1975	Whyte	4,475,209	A	10/1984	Udren
3,921,949	A	11/1975	Coon	4,477,814	A	10/1984	Brumbaugh et al.
3,925,763	A	12/1975	Wadhvani	4,482,899	A	11/1984	Dragone et al.
3,935,577	A	1/1976	Hansen et al.	4,488,156	A	12/1984	DuFort et al.
3,936,836	A	2/1976	Wheeler et al.	4,491,386	A	1/1985	Negishi et al.
3,936,838	A	2/1976	Foldes et al.	4,495,498	A	1/1985	Petrelis et al.
3,952,984	A	4/1976	Dimitry et al.	4,516,130	A	5/1985	Dragone
				4,525,432	A	6/1985	Saito et al.
				4,525,693	A	6/1985	Suzuki et al.
				4,533,875	A	8/1985	Lau et al.
				4,541,303	A	9/1985	Kuzunishi et al.

(56)

References Cited

U.S. PATENT DOCUMENTS

4,550,271	A	10/1985	Lau et al.	4,897,663	A	1/1990	Kusano et al.
4,553,112	A	11/1985	Saad et al.	4,904,996	A	2/1990	Fernandes
4,556,271	A	12/1985	Hubbard	4,915,468	A	4/1990	Kim et al.
4,558,325	A	12/1985	Stroem et al.	4,916,460	A	4/1990	Powell et al.
4,565,348	A	1/1986	Larsen	4,922,180	A	5/1990	Saffer et al.
4,566,012	A	1/1986	Choung et al.	4,929,962	A	5/1990	Begout et al.
4,567,401	A	1/1986	Barnett et al.	4,931,808	A	6/1990	Munson et al.
4,568,943	A	2/1986	Bowman	4,932,620	A	6/1990	Foy
4,573,215	A	2/1986	Oates et al.	4,946,202	A	8/1990	Perricone et al.
4,589,424	A	5/1986	Vaguine et al.	4,956,620	A	9/1990	Moeller et al.
4,598,262	A	7/1986	Chen et al.	4,965,856	A	10/1990	Swanic
4,599,598	A	7/1986	Komoda et al.	4,977,593	A	12/1990	Ballance
4,604,551	A	8/1986	Moeller et al.	4,977,618	A	12/1990	Allen
4,604,624	A	8/1986	Amitay et al.	4,989,011	A	1/1991	Rosen et al.
4,604,627	A	8/1986	Saad et al.	4,998,095	A	3/1991	Shields
4,618,867	A	10/1986	Gans et al.	5,003,318	A	3/1991	Hall et al.
4,636,753	A	1/1987	Geller et al.	5,006,846	A	4/1991	Granville et al.
4,638,322	A	1/1987	Lamberty et al.	5,006,859	A	4/1991	Wong et al.
4,641,916	A	2/1987	Oestreich et al.	5,015,914	A	5/1991	Ives et al.
4,642,651	A	2/1987	Kuhn et al.	5,017,936	A	5/1991	Massey et al.
4,644,365	A	2/1987	Horning et al.	5,017,937	A	5/1991	Newham et al.
4,647,329	A	3/1987	Oono et al.	5,018,180	A	5/1991	Shoulders
4,660,050	A	4/1987	Phillips et al.	5,019,832	A	5/1991	Ekdahl et al.
4,665,660	A	5/1987	Krall et al.	5,036,335	A	7/1991	Jairam et al.
4,672,384	A	6/1987	Roy et al.	H956	H	8/1991	Reindel
4,673,943	A	6/1987	Hannan	5,042,903	A	8/1991	Jakubowski et al.
4,680,558	A	7/1987	Ghosh et al.	5,043,538	A	8/1991	Hughey et al.
4,694,599	A	9/1987	Hart et al.	5,043,629	A	8/1991	Doane et al.
4,704,611	A	11/1987	Edwards et al.	5,044,722	A	9/1991	Voser et al.
4,715,695	A	12/1987	Nishimura et al.	5,045,820	A	9/1991	Oehlerking et al.
4,717,974	A	1/1988	Baumeister et al.	5,057,106	A	10/1991	Kasevich et al.
4,728,910	A	3/1988	Owens et al.	5,065,760	A	11/1991	Krause et al.
4,730,172	A	3/1988	Bengeult	5,065,969	A	11/1991	McLean et al.
4,730,888	A	3/1988	Darcie et al.	5,072,228	A	12/1991	Kuwahara et al.
4,731,810	A	3/1988	Watkins	5,082,349	A	1/1992	Cordova-Plaza et al.
4,735,097	A	4/1988	Lynnworth et al.	5,086,467	A	2/1992	Malek
4,743,915	A	5/1988	Rammos et al.	5,107,231	A	4/1992	Knox et al.
4,743,916	A	5/1988	Bengeult	5,109,232	A	4/1992	Monte et al.
4,745,377	A	5/1988	Stern et al.	5,113,197	A	5/1992	Luh et al.
4,746,241	A	5/1988	Burbank, III et al.	5,117,237	A	5/1992	Legg
4,749,244	A	6/1988	Luh	5,121,129	A	6/1992	Lee et al.
4,755,830	A	7/1988	Plunk et al.	5,126,750	A	6/1992	Wang et al.
4,757,324	A	7/1988	Dhanjal et al.	5,132,968	A	7/1992	Cephus
4,758,962	A	7/1988	Fernandes	5,134,251	A	7/1992	Martin et al.
4,764,738	A	8/1988	Fried et al.	5,134,423	A	7/1992	Haupt et al.
4,772,891	A	9/1988	Svy	5,134,965	A	8/1992	Tokuda et al.
4,777,457	A	10/1988	Ghosh et al.	5,136,671	A	8/1992	Dragone et al.
4,785,304	A	11/1988	Stern et al.	5,142,767	A	9/1992	Adams et al.
4,786,913	A	11/1988	Barendregt et al.	5,148,509	A	9/1992	Kannabiran et al.
4,788,553	A	11/1988	Phillips et al.	5,152,861	A	10/1992	Hann
4,792,771	A	12/1988	Siu et al.	5,153,676	A	10/1992	Bergh et al.
4,792,812	A	12/1988	Rinehart et al.	5,166,698	A	11/1992	Ashbaugh et al.
4,799,031	A	1/1989	Lang et al.	5,174,164	A	12/1992	Wilhelm et al.
4,800,350	A	1/1989	Bridges et al.	5,175,560	A	12/1992	Lucas et al.
4,801,937	A	1/1989	Fernandes	5,182,427	A	1/1993	McGaffigan et al.
4,818,963	A	4/1989	Green et al.	5,187,409	A	2/1993	Ito et al.
4,818,990	A	4/1989	Fernandes	5,193,774	A	3/1993	Rogers et al.
4,821,006	A	4/1989	Ishikawa et al.	5,198,823	A	3/1993	Litchford et al.
4,825,221	A	4/1989	Suzuki et al.	5,212,755	A	5/1993	Holmberg et al.
4,829,310	A	5/1989	Losee et al.	5,214,394	A	5/1993	Wong et al.
4,829,314	A	5/1989	Barbier et al.	5,214,438	A	5/1993	Smith et al.
4,831,346	A	5/1989	Brooker et al.	5,216,616	A	6/1993	Masters
4,832,148	A	5/1989	Becker et al.	5,218,657	A	6/1993	Tokudome et al.
4,835,517	A	5/1989	Van Der Gracht et al.	5,235,662	A	8/1993	Prince et al.
4,839,659	A	6/1989	Stern et al.	5,239,537	A	8/1993	Sakauchi
4,845,508	A	7/1989	Krall et al.	5,241,321	A	8/1993	Tsao et al.
4,847,610	A	7/1989	Ozawa et al.	5,241,701	A	8/1993	Andoh et al.
4,849,611	A	7/1989	Whitney et al.	5,248,876	A	9/1993	Kerstens et al.
4,851,788	A	7/1989	Ives et al.	5,254,809	A	10/1993	Martin
4,855,749	A	8/1989	DeFonzo et al.	5,265,266	A	11/1993	Trinh
4,866,454	A	9/1989	Droessler et al.	5,266,961	A	11/1993	Milroy et al.
4,873,534	A	10/1989	Wohlleben et al.	5,276,455	A	1/1994	Fitzsimmons et al.
4,879,544	A	11/1989	Maki et al.	5,278,687	A	1/1994	Jannson et al.
4,881,028	A	11/1989	Bright et al.	5,280,297	A	1/1994	Profera et al.
4,886,980	A	12/1989	Fernandes et al.	5,291,211	A	3/1994	Tropper et al.
				5,298,911	A	3/1994	Li et al.
				5,299,773	A	4/1994	Bertrand et al.
				5,304,999	A	4/1994	Roberts et al.
				5,311,596	A	5/1994	Scott et al.

(56)

References Cited

U.S. PATENT DOCUMENTS		
5,327,149	A	7/1994 Kuffer et al.
5,329,285	A	7/1994 McCandless et al.
5,341,088	A	8/1994 David
5,345,522	A	9/1994 Vali et al.
5,347,287	A	9/1994 Speciale et al.
5,352,984	A	10/1994 Piesinger et al.
5,353,036	A	10/1994 Baldry
5,359,338	A	10/1994 Hatcher et al.
5,371,623	A	12/1994 Eastmond et al.
5,379,455	A	1/1995 Koschek et al.
5,380,224	A	1/1995 DiCicco
5,381,160	A	1/1995 Landmeier
5,389,442	A	2/1995 Kathiresan et al.
5,400,040	A	3/1995 Lane et al.
5,402,140	A	3/1995 Rodeffer et al.
5,402,151	A	3/1995 Duwaer
5,404,146	A	4/1995 Rutledge et al.
5,410,318	A	4/1995 Wong et al.
5,412,654	A	5/1995 Perkins
5,428,364	A	6/1995 Lee et al.
5,428,818	A	6/1995 Meidan et al.
5,434,575	A	7/1995 Jelinek et al.
5,440,660	A	8/1995 Dombrowski et al.
5,451,969	A	9/1995 Toth et al.
5,457,469	A	10/1995 Diamond et al.
5,479,176	A	12/1995 Zavrel et al.
5,481,268	A	1/1996 Higgins
5,482,525	A	1/1996 Kajjoka et al.
5,486,839	A	1/1996 Rodeffer et al.
5,488,380	A	1/1996 Harvey et al.
5,495,546	A	2/1996 Bottoms et al.
5,499,308	A	3/1996 Arai et al.
5,499,311	A	3/1996 DeCusatis et al.
5,502,392	A	3/1996 Arjavalingam et al.
5,512,906	A	4/1996 Speciale et al.
5,513,176	A	4/1996 Dean et al.
5,514,965	A	5/1996 Westwood et al.
5,515,059	A	5/1996 How et al.
5,519,408	A	5/1996 Schnetzer et al.
5,528,208	A	6/1996 Kobayashi et al.
5,539,421	A	7/1996 Hong et al.
5,543,000	A	8/1996 Lique
5,557,283	A	9/1996 Sheen
5,559,359	A	9/1996 Reyes
5,566,022	A	10/1996 Segev
5,566,196	A	10/1996 Scifres
5,576,721	A	11/1996 Hwang et al.
5,586,054	A	12/1996 Jensen et al.
5,592,183	A	1/1997 Henf
5,600,630	A	2/1997 Takahashi et al.
5,603,089	A	2/1997 Searle et al.
5,619,015	A	4/1997 Kirma
5,621,421	A	4/1997 Kolz et al.
5,627,879	A	5/1997 Russell et al.
5,628,050	A	5/1997 McGraw et al.
5,630,223	A	5/1997 Bahu et al.
5,637,521	A	6/1997 Rhodes et al.
5,640,168	A	6/1997 Heger et al.
5,646,936	A	7/1997 Shah et al.
5,650,788	A	7/1997 Jha
5,652,554	A	7/1997 Krieg et al.
5,663,693	A	9/1997 Doughty et al.
5,671,304	A	9/1997 Duguay
5,677,699	A	10/1997 Strickland
5,677,909	A	10/1997 Heide
5,680,139	A	10/1997 Huguenin et al.
5,682,256	A	10/1997 Motley et al.
5,684,495	A	11/1997 Dyott et al.
5,686,930	A	11/1997 Brydon
5,724,168	A	3/1998 Oschmann et al.
5,726,980	A	3/1998 Rickard et al.
5,748,153	A	5/1998 McKinzie et al.
5,750,941	A	5/1998 Ishikawa et al.
5,757,323	A	5/1998 Spencer et al.
5,767,807	A	6/1998 Pritchett et al.
5,768,689	A	6/1998 Borg
5,769,879	A	6/1998 Levay et al.
5,784,033	A	7/1998 Boldissar, Jr. et al.
5,784,034	A	7/1998 Konishi et al.
5,784,683	A	7/1998 Sistanizadeh et al.
5,787,673	A	8/1998 Noble
5,793,334	A	8/1998 Harrison et al.
5,800,494	A	9/1998 Campbell et al.
5,805,983	A	9/1998 Naidu et al.
5,809,395	A	9/1998 Hamilton-Piercy et al.
5,812,524	A	9/1998 Moran et al.
5,818,390	A	10/1998 Hill
5,818,396	A	10/1998 Harrison et al.
5,818,512	A	10/1998 Fuller
5,845,391	A	12/1998 Miklosko et al.
5,848,054	A	12/1998 Mosebrook et al.
5,850,199	A	12/1998 Wan et al.
5,854,608	A	12/1998 Leisten
5,859,618	A	1/1999 Miller, II et al.
5,861,843	A	1/1999 Sorace et al.
5,867,763	A	2/1999 Dean et al.
5,870,060	A	2/1999 Chen et al.
5,872,544	A	2/1999 Schay et al.
5,872,547	A	2/1999 Martek
5,873,324	A	2/1999 Kaddas et al.
5,886,666	A	3/1999 Schellenberg et al.
5,889,449	A	3/1999 Fiedziuszek
5,890,055	A	3/1999 Chu et al.
5,892,480	A	4/1999 Killen et al.
5,898,133	A	4/1999 Bleich et al.
5,898,830	A	4/1999 Wesinger, Jr. et al.
5,900,847	A	5/1999 Ishikawa et al.
5,903,373	A	5/1999 Welch et al.
5,905,438	A	5/1999 Weiss et al.
5,905,949	A	5/1999 Hawkes et al.
5,910,790	A	6/1999 Ohmuro et al.
5,917,977	A	6/1999 Barrett et al.
5,922,081	A	7/1999 Seewig et al.
5,926,128	A	7/1999 Brash et al.
5,933,422	A	8/1999 Suzuki et al.
5,936,589	A	8/1999 Kawahata
5,948,044	A	9/1999 Varley et al.
5,948,108	A	9/1999 Lu et al.
5,952,964	A	9/1999 Chan et al.
5,952,972	A	9/1999 Ittipiboon et al.
5,952,984	A	9/1999 Kuramoto et al.
5,955,992	A	9/1999 Shattil
5,959,578	A	9/1999 Kreutel et al.
5,959,590	A	9/1999 Sanford et al.
5,973,641	A	10/1999 Smith et al.
5,977,650	A	11/1999 Rickard et al.
5,978,738	A	11/1999 Brown et al.
5,982,276	A	11/1999 Stewart
5,986,331	A	11/1999 Letavic et al.
5,987,099	A	11/1999 O'Neill et al.
5,990,848	A	11/1999 Annamaa et al.
5,994,984	A	11/1999 Stancil et al.
5,994,998	A	11/1999 Fisher et al.
6,005,694	A	12/1999 Liu
6,005,758	A	12/1999 Spencer et al.
6,009,124	A	12/1999 Smith
6,011,520	A	1/2000 Howell et al.
6,011,524	A	1/2000 Jervis et al.
6,014,110	A	1/2000 Bridges et al.
6,018,659	A	1/2000 Ayyagari et al.
6,023,619	A	2/2000 Kaminsky
6,026,173	A	2/2000 Svenson et al.
6,026,208	A	2/2000 Will et al.
6,026,331	A	2/2000 Feldberg et al.
6,031,455	A	2/2000 Grube et al.
6,034,638	A	3/2000 Thiel et al.
6,037,894	A	3/2000 Pfizenmaier et al.
6,038,425	A	3/2000 Jeffrey et al.
6,049,647	A	4/2000 Register et al.
6,057,802	A	5/2000 Nealy
6,061,035	A	5/2000 Kinasewitz et al.
6,063,234	A	5/2000 Chen et al.
6,075,451	A	6/2000 Lebowitz et al.
6,075,493	A	6/2000 Sugawara et al.

(56)

References Cited

U.S. PATENT DOCUMENTS

6,076,044	A	6/2000	Brown et al.	6,357,709	B1	3/2002	Parduhn et al.
6,078,297	A	6/2000	Kormanyos et al.	6,362,788	B1	3/2002	Louzir
6,088,001	A	7/2000	Burger et al.	6,362,789	B1	3/2002	Trumbull et al.
6,095,820	A	8/2000	Luxon et al.	6,366,238	B1	4/2002	DeMore et al.
6,100,846	A	8/2000	Li et al.	6,373,436	B1	4/2002	Chen et al.
6,103,031	A	8/2000	Aeschbacher et al.	6,373,441	B1	4/2002	Porath et al.
6,107,897	A	8/2000	Hewett et al.	6,376,824	B1	4/2002	Michenfelder et al.
6,111,553	A	8/2000	Steenbuck et al.	6,388,564	B1	5/2002	Piercy et al.
6,114,998	A	9/2000	Scheffe et al.	6,396,440	B1	5/2002	Chen et al.
6,121,885	A	9/2000	Masone et al.	6,404,773	B1	6/2002	Williams et al.
6,122,753	A	9/2000	Masuo et al.	6,404,775	B1	6/2002	Leslie
6,140,911	A	10/2000	Fisher et al.	6,421,021	B1	7/2002	Rupp et al.
6,140,976	A	10/2000	Locke et al.	6,433,736	B1	8/2002	Timothy et al.
6,142,434	A	11/2000	Brinkman et al.	6,433,741	B2	8/2002	Tanizaki et al.
6,146,330	A	11/2000	Tujino et al.	6,436,536	B2	8/2002	Peruzzotti et al.
6,150,612	A	11/2000	Grandy et al.	6,441,723	B1	8/2002	Mansfield, Jr. et al.
6,151,145	A	11/2000	Srivastava et al.	6,445,351	B1	9/2002	Baker et al.
6,154,488	A	11/2000	Hunt	6,445,774	B1	9/2002	Kidder et al.
6,158,383	A	12/2000	Watanabe et al.	6,452,467	B1	9/2002	McEwan
6,163,296	A	12/2000	Lier et al.	6,452,569	B1	9/2002	Park et al.
6,166,694	A	12/2000	Ying et al.	6,452,923	B1	9/2002	Gerszberg et al.
6,167,055	A	12/2000	Ganek et al.	6,455,769	B1	9/2002	Belli et al.
6,175,917	B1	1/2001	Arrow et al.	6,456,251	B1	9/2002	Rao et al.
6,177,801	B1	1/2001	Chong et al.	6,462,700	B1	10/2002	Schmidt et al.
6,184,828	B1	2/2001	Shoki et al.	6,463,295	B1	10/2002	Yun et al.
6,195,058	B1	2/2001	Nakamura et al.	6,469,676	B1	10/2002	Fehrenbach et al.
6,195,395	B1	2/2001	Frodsham et al.	6,473,049	B2	10/2002	Takeuchi et al.
6,198,440	B1	3/2001	Krylov et al.	6,480,168	B1	11/2002	Lam et al.
6,208,161	B1	3/2001	Suda et al.	6,483,470	B1	11/2002	Hohnstein et al.
6,208,308	B1	3/2001	Lemons et al.	6,489,928	B2	12/2002	Sakurada
6,208,903	B1	3/2001	Richards et al.	6,489,931	B2	12/2002	Liu et al.
6,211,836	B1	4/2001	Manasson et al.	6,492,957	B2	12/2002	Carillo, Jr. et al.
6,211,837	B1	4/2001	Crouch et al.	6,501,433	B2	12/2002	Popa et al.
6,215,443	B1	4/2001	Komatsu et al.	6,507,573	B1	1/2003	Brandt et al.
6,219,006	B1	4/2001	Rudish et al.	6,510,152	B1	1/2003	Gerszberg et al.
6,222,503	B1	4/2001	Gietema et al.	6,515,635	B2	2/2003	Chiang et al.
6,225,960	B1	5/2001	Collins et al.	6,522,305	B2	2/2003	Sharman et al.
6,229,327	B1	5/2001	Boll et al.	6,531,991	B2	3/2003	Adachi et al.
6,236,365	B1	5/2001	Karr et al.	6,532,215	B1	3/2003	Muntz et al.
6,239,377	B1	5/2001	Nishikawa et al.	6,534,996	B1	3/2003	Amrany et al.
6,239,379	B1	5/2001	Cotter et al.	6,535,169	B2	3/2003	Fourdeux et al.
6,239,761	B1	5/2001	Guo et al.	6,542,739	B1	4/2003	Garner
6,241,045	B1	6/2001	Reeve et al.	6,549,106	B2	4/2003	Martin et al.
6,243,049	B1	6/2001	Chandler et al.	6,549,173	B1	4/2003	King et al.
6,246,821	B1	6/2001	Hemken et al.	6,552,693	B1	4/2003	Leisten et al.
6,252,553	B1	6/2001	Solomon et al.	6,559,811	B1	5/2003	Cash et al.
6,259,337	B1	7/2001	Wen et al.	6,563,981	B2	5/2003	Weisberg et al.
6,266,016	B1	7/2001	Bergstedt et al.	6,567,573	B1	5/2003	Domash et al.
6,266,025	B1	7/2001	Popa et al.	6,573,803	B1	6/2003	Ziegner et al.
6,268,835	B1	7/2001	Toland et al.	6,573,813	B1	6/2003	Joannopoulos et al.
6,271,790	B2	8/2001	Smith et al.	6,580,295	B2	6/2003	Takekuma et al.
6,271,799	B1	8/2001	Rief et al.	6,584,084	B1	6/2003	Barany et al.
6,271,952	B1	8/2001	Epworth et al.	6,584,252	B1	6/2003	Schier et al.
6,278,357	B1	8/2001	Croushore et al.	6,587,077	B2	7/2003	Vail et al.
6,278,370	B1	8/2001	Underwood et al.	6,593,893	B2	7/2003	Hou et al.
6,281,855	B1	8/2001	Aoki et al.	6,594,238	B1	7/2003	Wallentin et al.
6,282,354	B1	8/2001	Jones et al.	6,596,944	B1	7/2003	Clark et al.
6,283,425	B1	9/2001	Liljevik	6,600,456	B2	7/2003	Gothard et al.
6,285,325	B1	9/2001	Nalbandian et al.	6,606,057	B2	8/2003	Chiang et al.
6,292,139	B1	9/2001	Yamamoto et al.	6,606,066	B1	8/2003	Fawcett et al.
6,292,143	B1	9/2001	Romanofsky et al.	6,606,077	B2	8/2003	Ebling et al.
6,292,153	B1	9/2001	Aiello et al.	6,611,252	B1	8/2003	DuFaux et al.
6,300,898	B1	10/2001	Schneider et al.	6,614,237	B2	9/2003	Ademian et al.
6,300,906	B1	10/2001	Rawnick et al.	6,628,859	B2	9/2003	Huang et al.
6,301,420	B1	10/2001	Greenaway et al.	6,631,229	B1	10/2003	Norris et al.
6,308,085	B1	10/2001	Shoki et al.	6,634,225	B1	10/2003	Reime et al.
6,311,288	B1	10/2001	Heeren et al.	6,639,484	B2	10/2003	Tzuang et al.
6,317,028	B1	11/2001	Valiulis et al.	6,639,566	B2	10/2003	Knop et al.
6,317,092	B1	11/2001	de Schweinitz et al.	6,642,887	B2	11/2003	Owechko et al.
6,320,509	B1	11/2001	Brady et al.	6,643,254	B1	11/2003	Abe et al.
6,320,553	B1	11/2001	Ergene et al.	6,650,296	B2	11/2003	Wong et al.
6,323,819	B1	11/2001	Ergene et al.	6,653,598	B2	11/2003	Sullivan et al.
6,329,959	B1	12/2001	Varadan et al.	6,653,848	B2	11/2003	Adamian et al.
6,348,683	B1	2/2002	Verghese et al.	6,657,437	B1	12/2003	LeCroy et al.
6,351,247	B1	2/2002	Linstrom et al.	6,659,655	B2	12/2003	Dair et al.
				6,661,391	B2	12/2003	Ohara et al.
				6,668,104	B1	12/2003	Mueller-Fiedler et al.
				6,670,921	B2	12/2003	Sievenpiper et al.
				6,671,824	B1	12/2003	Hyland et al.

(56)

References Cited

U.S. PATENT DOCUMENTS

6,677,899	B1	1/2004	Lee et al.	6,924,732	B2	8/2005	Yokoo et al.
6,680,903	B1	1/2004	Moriguchi et al.	6,924,776	B2	8/2005	Le et al.
6,683,580	B2	1/2004	Kuramoto	6,933,887	B2	8/2005	Regnier et al.
6,686,832	B2	2/2004	Abraham et al.	6,934,655	B2	8/2005	Jones et al.
6,686,873	B2	2/2004	Patel et al.	6,937,595	B2	8/2005	Barzegar et al.
6,686,875	B1	2/2004	Wolfson et al.	6,943,553	B2	9/2005	Zimmermann et al.
6,697,027	B2	2/2004	Mahon et al.	6,944,555	B2	9/2005	Blackett et al.
6,697,030	B2	2/2004	Gleener	6,947,147	B2	9/2005	Motamedi et al.
6,703,981	B2	3/2004	Meitzler et al.	6,947,376	B1	9/2005	Deng et al.
6,714,165	B2	3/2004	Verstraeten	6,947,635	B2	9/2005	Kohns et al.
6,720,935	B2	4/2004	Lamensdorf et al.	6,948,371	B2	9/2005	Tanaka et al.
6,725,035	B2	4/2004	Jochim et al.	6,950,567	B2	9/2005	Kline et al.
6,727,470	B2	4/2004	Reichle et al.	6,952,143	B2	10/2005	Kinayman et al.
6,727,891	B2	4/2004	Moriya et al.	6,952,183	B2	10/2005	Yuanzhu et al.
6,728,439	B2	4/2004	Weisberg et al.	6,956,506	B2	10/2005	Koivumaeki et al.
6,728,552	B2	4/2004	Chatain et al.	6,958,729	B1	10/2005	Metz et al.
6,731,210	B2	5/2004	Swanson et al.	6,965,302	B2	11/2005	Mollenkopf et al.
6,731,649	B1	5/2004	Silverman	6,965,355	B1	11/2005	Durham et al.
6,741,705	B1	5/2004	Nelson et al.	6,965,784	B2	11/2005	Kanamaluru et al.
6,747,557	B1	6/2004	Petite et al.	6,967,627	B2	11/2005	Roper et al.
6,750,827	B2	6/2004	Manasson et al.	6,970,502	B2	11/2005	Kim et al.
6,754,470	B2	6/2004	Hendrickson et al.	6,970,682	B2	11/2005	Crilly, Jr. et al.
6,755,312	B2	6/2004	Dziedzic et al.	6,972,729	B2	12/2005	Wang et al.
6,756,538	B1	6/2004	Murga-Gonzalez et al.	6,980,091	B2	12/2005	White, II et al.
6,765,479	B2	7/2004	Stewart et al.	6,982,611	B2	1/2006	Cope et al.
6,768,454	B2	7/2004	Kingsley et al.	6,982,679	B2	1/2006	Kralovec et al.
6,768,456	B1	7/2004	Lalezari et al.	6,983,174	B2	1/2006	Hoppenstein et al.
6,768,471	B2	7/2004	Bostwick et al.	6,985,118	B2	1/2006	Killen et al.
6,768,474	B2	7/2004	Hunt et al.	6,992,639	B1	1/2006	Lier et al.
6,771,216	B2	8/2004	Patel et al.	6,999,667	B2	2/2006	Jang et al.
6,771,225	B2	8/2004	Tiis et al.	7,008,120	B2	3/2006	Zaborsky et al.
6,771,739	B1	8/2004	Beamon et al.	7,009,471	B2	3/2006	Elmore
6,774,859	B2	8/2004	Schantz et al.	7,012,489	B2	3/2006	Fisher et al.
6,788,865	B2	9/2004	Kawanishi et al.	7,012,572	B1	3/2006	Schaffner et al.
6,788,951	B2	9/2004	Aoki et al.	7,016,585	B2	3/2006	Diggle, III et al.
6,789,119	B1	9/2004	Zhu et al.	7,019,704	B2	3/2006	Weiss et al.
6,792,290	B2	9/2004	Proctor, Jr. et al.	7,023,400	B2	4/2006	Hill et al.
6,798,223	B2	9/2004	Huang et al.	7,026,917	B2	4/2006	Berkman et al.
6,806,710	B1	10/2004	Renz et al.	7,027,003	B2	4/2006	Sasaki et al.
6,809,633	B2	10/2004	Cern et al.	7,027,454	B2	4/2006	Dent et al.
6,809,695	B2	10/2004	Le Bayon et al.	7,032,016	B2	4/2006	Cerami et al.
6,812,895	B2	11/2004	Anderson et al.	7,038,636	B2	5/2006	Larouche et al.
6,819,744	B1	11/2004	Galli et al.	7,039,048	B1	5/2006	Monta et al.
6,822,615	B2	11/2004	Quan et al.	7,042,403	B2	5/2006	Sievenpiper et al.
6,839,032	B2	1/2005	Teshirogi et al.	7,042,416	B2	5/2006	Kingsley et al.
6,839,160	B2	1/2005	Tsuda et al.	7,042,420	B2	5/2006	Ebling et al.
6,839,846	B2	1/2005	Mangold et al.	7,054,286	B2	5/2006	Ertel et al.
6,842,157	B2	1/2005	Phelan et al.	7,054,376	B1	5/2006	Rubinstain et al.
6,842,430	B1	1/2005	Melnik et al.	7,054,513	B2	5/2006	Herz et al.
6,850,128	B2	2/2005	Park	7,055,148	B2	5/2006	Marsh et al.
6,853,351	B1	2/2005	Mohuchy et al.	7,057,558	B2	6/2006	Yasuho et al.
6,856,273	B1	2/2005	Bognar et al.	7,057,573	B2	6/2006	Ohira et al.
6,859,185	B2	2/2005	Royalty et al.	7,058,524	B2	6/2006	Hayes et al.
6,859,187	B2	2/2005	Ohlsson et al.	7,061,370	B2	6/2006	Cern et al.
6,859,590	B1	2/2005	Zacccone	7,061,891	B1	6/2006	Kilfoyle et al.
6,861,998	B2	3/2005	Louzir	7,064,726	B2	6/2006	Kitamori et al.
6,864,851	B2	3/2005	McGrath et al.	7,068,998	B2	6/2006	Zavidniak et al.
6,864,853	B2	3/2005	Judd et al.	7,069,163	B2	6/2006	Gunther et al.
6,867,744	B2	3/2005	Toncich et al.	7,075,414	B2	7/2006	Giannini et al.
6,868,258	B2	3/2005	Hayata et al.	7,075,485	B2	7/2006	Song et al.
6,870,465	B1	3/2005	Song et al.	7,075,496	B2	7/2006	Hidai et al.
6,873,265	B2	3/2005	Bleier et al.	7,082,321	B2	7/2006	kuwahara et al.
6,885,674	B2	4/2005	Hunt et al.	7,084,742	B2	8/2006	Haines et al.
6,886,065	B2	4/2005	Sides et al.	7,088,221	B2	8/2006	Chan
6,888,623	B2	5/2005	Clements	7,088,306	B2	8/2006	Chiang et al.
6,901,064	B2	5/2005	Billhartz et al.	7,098,405	B2	8/2006	Glew et al.
6,904,218	B2	6/2005	Sun et al.	7,098,773	B2	8/2006	Berkman et al.
6,906,676	B2	6/2005	Killen et al.	7,102,581	B1	9/2006	West et al.
6,906,681	B2	6/2005	Hoppenstein et al.	7,106,265	B2	9/2006	Robertson et al.
6,909,893	B2	6/2005	Aoki et al.	7,106,270	B2	9/2006	Iigusa et al.
6,917,974	B1	7/2005	Stytz et al.	7,106,273	B1	9/2006	Brunson et al.
6,920,289	B2	7/2005	Zimmerman et al.	7,109,939	B2	9/2006	Lynch et al.
6,920,315	B1	7/2005	Wilcox et al.	7,113,002	B2	9/2006	Otsuka et al.
6,920,407	B2	7/2005	Phillips et al.	7,113,134	B1	9/2006	Berkman et al.
6,922,135	B2	7/2005	Abraham et al.	7,119,755	B2	10/2006	Harvey et al.
				7,120,338	B2	10/2006	Gunn, III et al.
				7,120,345	B2	10/2006	Naitou et al.
				7,122,012	B2	10/2006	Bouton et al.
				7,123,191	B2	10/2006	Goldberg et al.

(56)

References Cited

U.S. PATENT DOCUMENTS

7,123,801	B2	10/2006	Fitz et al.	7,301,440	B2	11/2007	Mollenkopf
7,125,512	B2	10/2006	Crump et al.	7,301,508	B1	11/2007	O'Loughlin et al.
7,126,557	B2	10/2006	Warnagiris et al.	7,307,357	B2	12/2007	Kopp et al.
7,126,711	B2	10/2006	Fruth	7,307,596	B1	12/2007	West et al.
7,130,516	B2	10/2006	Wu et al.	7,308,264	B2	12/2007	Stern-Berkowitz et al.
7,132,950	B2	11/2006	Stewart et al.	7,308,370	B2	12/2007	Mason, Jr. et al.
7,133,930	B2	11/2006	Sabio et al.	7,309,873	B2	12/2007	Ishikawa
7,134,012	B2	11/2006	Doyle et al.	7,310,065	B2	12/2007	Anguera et al.
7,134,135	B2	11/2006	Cerami et al.	7,310,335	B1	12/2007	Garcia-Luna-Aceves et al.
7,136,397	B2	11/2006	Sharma et al.	7,311,605	B2	12/2007	Moser
7,136,772	B2	11/2006	Duchi et al.	7,312,686	B2	12/2007	Bruno
7,137,605	B1	11/2006	Guertler et al.	7,313,087	B2	12/2007	Patil et al.
7,138,767	B2	11/2006	Chen et al.	7,313,312	B2	12/2007	Kimball et al.
7,138,958	B2	11/2006	Syed et al.	7,315,224	B2	1/2008	Gurovich et al.
7,139,328	B2	11/2006	Thomas et al.	7,315,678	B2	1/2008	Siegel
7,145,440	B2	12/2006	Gerszberg et al.	7,318,564	B1	1/2008	Marshall et al.
7,145,552	B2	12/2006	Hollingsworth et al.	7,319,717	B2	1/2008	Zitting et al.
7,151,497	B2	12/2006	Crystal et al.	7,321,291	B2	1/2008	Gidge et al.
7,151,508	B2	12/2006	Schaffner et al.	7,321,707	B2	1/2008	Noda et al.
7,155,238	B2	12/2006	Katz et al.	7,324,046	B1	1/2008	Wu et al.
7,161,934	B2	1/2007	Buchsbaum et al.	7,324,817	B2	1/2008	Iacono et al.
7,164,354	B1	1/2007	Panzer et al.	7,329,815	B2	2/2008	Johnston et al.
7,167,139	B2	1/2007	Kim et al.	7,333,064	B1	2/2008	Timothy et al.
7,171,087	B2	1/2007	Takahashi et al.	7,333,593	B2	2/2008	Beamon et al.
7,171,308	B2	1/2007	Campbell et al.	7,339,466	B2	3/2008	Mansfield et al.
7,171,493	B2	1/2007	Shu et al.	7,339,897	B2	3/2008	Larsson et al.
7,176,589	B2	2/2007	Rouquette et al.	7,340,768	B2	3/2008	Rosenberger et al.
7,180,459	B2	2/2007	Damini et al.	7,345,623	B2	3/2008	McEwan et al.
7,180,467	B2	2/2007	Fabrega-Sanchez	7,346,244	B2	3/2008	Gowan et al.
7,183,922	B2	2/2007	Mendolia et al.	7,346,359	B2	3/2008	Damarla et al.
7,183,991	B2	2/2007	Bhattacharyya et al.	7,353,293	B2	4/2008	Hipfinger et al.
7,183,998	B2	2/2007	Wilhelm et al.	7,355,560	B2	4/2008	Nagai et al.
7,193,562	B2	3/2007	Kish et al.	7,358,808	B2	4/2008	Berkman et al.
7,194,528	B1	3/2007	Davidow et al.	7,358,921	B2	4/2008	Snyder et al.
7,199,680	B2	4/2007	Fukunaga et al.	7,369,085	B1	5/2008	Jacomb-Hood et al.
7,200,391	B2	4/2007	Chung et al.	7,369,095	B2	5/2008	Thudor et al.
7,200,658	B2	4/2007	Goeller et al.	7,376,191	B2	5/2008	Melick et al.
7,205,950	B2	4/2007	Imai et al.	7,380,272	B2	5/2008	Sharp et al.
7,212,163	B2	5/2007	Huang et al.	7,381,089	B2	6/2008	Hosler, Sr.
7,215,220	B1	5/2007	Jia et al.	7,382,232	B2	6/2008	Gidge et al.
7,215,928	B2	5/2007	Gage et al.	7,383,577	B2	6/2008	Hrastar et al.
7,218,285	B2	5/2007	Davis et al.	7,388,450	B2	6/2008	Camiade et al.
7,224,170	B2	5/2007	Graham et al.	7,397,422	B2	7/2008	Tekawy et al.
7,224,243	B2	5/2007	Cope et al.	7,398,946	B1	7/2008	Marshall
7,224,272	B2	5/2007	White, II et al.	7,400,304	B2	7/2008	Lewis et al.
7,224,320	B2	5/2007	Cook et al.	7,403,169	B2	7/2008	Svensson et al.
7,224,985	B2	5/2007	Caci et al.	7,406,337	B2	7/2008	Kim et al.
7,228,123	B2	6/2007	Moursund et al.	7,408,426	B2	8/2008	Broyde et al.
7,234,413	B2	6/2007	Suzuki et al.	7,408,507	B1	8/2008	Paek et al.
7,234,895	B2	6/2007	Richardson et al.	7,408,923	B1	8/2008	Khan et al.
7,239,284	B1	7/2007	Staal et al.	7,410,606	B2	8/2008	Atkinson et al.
7,243,610	B2	7/2007	Ishii et al.	7,417,587	B2	8/2008	Iskander et al.
7,248,148	B2	7/2007	Kline et al.	7,418,178	B2	8/2008	Kudou et al.
7,250,772	B2	7/2007	Furse et al.	7,418,273	B2	8/2008	Suyama et al.
7,255,821	B2	8/2007	Priedeman, Jr. et al.	7,420,474	B1	9/2008	Elks et al.
7,259,657	B2	8/2007	Mollenkopf et al.	7,420,525	B2	9/2008	Colburn et al.
7,260,424	B2	8/2007	Schmidt et al.	7,423,604	B2	9/2008	Nagai et al.
7,266,154	B2	9/2007	Gundrum et al.	7,426,554	B2	9/2008	Kennedy et al.
7,266,275	B2	9/2007	Hansen et al.	7,427,927	B2	9/2008	Borleske et al.
7,272,281	B2	9/2007	Stahulak et al.	7,430,257	B1	9/2008	Shattil et al.
7,272,362	B2	9/2007	Jeong et al.	7,430,932	B2	10/2008	Mekhanoshin et al.
7,274,305	B1	9/2007	Luttrell	7,443,334	B2	10/2008	Rees et al.
7,274,936	B2	9/2007	Stern-Berkowitz et al.	7,444,404	B2	10/2008	Wetherall et al.
7,276,990	B2	10/2007	Sievenpiper et al.	7,446,567	B2	11/2008	Otsuka et al.
7,280,033	B2	10/2007	Berkman et al.	7,450,000	B2	11/2008	Gidge et al.
7,280,803	B2	10/2007	Nelson et al.	7,450,001	B2	11/2008	Berkman
7,282,922	B2	10/2007	Lo et al.	7,453,352	B2	11/2008	Kline et al.
7,286,099	B1	10/2007	Lier et al.	7,453,393	B2	11/2008	Duivendoorden et al.
7,289,449	B1	10/2007	Rubinstein et al.	7,456,650	B2	11/2008	Lee et al.
7,289,704	B1	10/2007	Wagman et al.	7,459,834	B2	12/2008	Knowles et al.
7,289,828	B2	10/2007	Cha et al.	7,460,834	B2	12/2008	Johnson et al.
7,292,125	B2	11/2007	Mansour et al.	7,463,877	B2	12/2008	Iwamura
7,292,196	B2	11/2007	Waterhouse et al.	7,465,879	B2	12/2008	Glew et al.
7,295,161	B2	11/2007	Gaucher et al.	7,466,225	B2	12/2008	White, II et al.
7,297,869	B2	11/2007	Hiller et al.	7,468,657	B2	12/2008	Yaney
				7,477,285	B1	1/2009	Johnson et al.
				7,479,776	B2	1/2009	Renken et al.
				7,479,841	B2	1/2009	Stenger et al.
				7,486,247	B2	2/2009	Ridgway et al.

(56)

References Cited

U.S. PATENT DOCUMENTS

7,490,275	B2	2/2009	Zerbe et al.	7,669,049	B2	2/2010	Wang et al.
7,492,317	B2	2/2009	Tinsley et al.	7,671,701	B2	3/2010	Radtke
7,496,674	B2	2/2009	Jorgensen et al.	7,671,820	B2	3/2010	Tokoro et al.
7,498,822	B2	3/2009	Lee et al.	7,672,271	B2	3/2010	Lee et al.
7,502,619	B1	3/2009	Katz et al.	7,676,679	B2	3/2010	Weis et al.
7,504,938	B2	3/2009	Eiza et al.	7,680,478	B2	3/2010	Willars et al.
7,508,834	B2	3/2009	Berkman et al.	7,680,516	B2	3/2010	Lovberg et al.
7,509,009	B2	3/2009	Suzuki et al.	7,680,561	B2	3/2010	Rodgers et al.
7,509,675	B2	3/2009	Aaron et al.	7,683,848	B2	3/2010	Musch et al.
7,511,662	B2	3/2009	Mathews et al.	7,684,383	B1	3/2010	Thompson et al.
7,512,090	B2	3/2009	Benitez Pelaez et al.	7,693,079	B2	4/2010	Cerami et al.
7,515,041	B2	4/2009	Eisold et al.	7,693,162	B2	4/2010	McKenna et al.
7,516,487	B1	4/2009	Szeto et al.	7,693,939	B2	4/2010	Wu et al.
7,518,529	B2	4/2009	O'Sullivan et al.	7,697,417	B2	4/2010	Chen et al.
7,518,952	B1	4/2009	Padden et al.	7,701,931	B2	4/2010	Kajiwara
7,519,323	B2	4/2009	Mohebbi et al.	7,705,747	B2	4/2010	Twitchell, Jr.
7,522,115	B2	4/2009	Waltman et al.	7,710,346	B2	5/2010	Bloss et al.
7,522,812	B2	4/2009	Zitting	7,714,536	B1	5/2010	Silberg et al.
7,525,501	B2	4/2009	Black et al.	7,714,709	B1	5/2010	Daniel et al.
7,525,504	B1	4/2009	Song et al.	7,714,725	B2	5/2010	Medve et al.
7,531,803	B2	5/2009	Mittleman et al.	7,715,672	B2	5/2010	Dong et al.
7,532,792	B2	5/2009	Skovgaard et al.	7,716,660	B2	5/2010	Mackay et al.
7,535,867	B1	5/2009	Kilfoyle et al.	7,724,782	B2	5/2010	Wang et al.
7,539,381	B2	5/2009	Li et al.	7,728,772	B2	6/2010	Mortazawi et al.
7,541,981	B2	6/2009	Piskun et al.	7,729,285	B2	6/2010	Yoon et al.
7,545,818	B2	6/2009	Chen et al.	7,733,094	B2	6/2010	Bright et al.
7,546,214	B2	6/2009	Rivers, Jr. et al.	7,734,717	B2	6/2010	Saarimäki et al.
7,548,212	B2	6/2009	Chekroun et al.	7,737,903	B1	6/2010	Rao et al.
7,551,921	B2	6/2009	Petermann et al.	7,739,402	B2	6/2010	Graham et al.
7,554,998	B2	6/2009	Simonsson et al.	7,743,403	B2	6/2010	McCarty et al.
7,555,182	B2	6/2009	Martin et al.	7,747,356	B2	6/2010	Andarawis et al.
7,555,186	B2	6/2009	De Montmorillo et al.	7,747,774	B2	6/2010	Aaron et al.
7,555,187	B2	6/2009	Bickham et al.	7,750,244	B1	7/2010	Melding et al.
7,557,563	B2	7/2009	Cowan et al.	7,750,763	B2	7/2010	Praßmayer et al.
7,561,025	B2	7/2009	Gerszberg et al.	7,751,054	B2	7/2010	Backes et al.
7,567,154	B2	7/2009	Elmore	7,760,978	B2	7/2010	Fishteyn et al.
7,567,740	B2	7/2009	Bayindir et al.	7,761,079	B2	7/2010	Mollenkopf et al.
7,570,137	B2	8/2009	Kintis et al.	7,764,943	B2	7/2010	Radtke et al.
7,570,470	B2	8/2009	Holley	7,773,664	B2	8/2010	Myers et al.
7,577,398	B2	8/2009	Tennant et al.	7,782,156	B2	8/2010	Woods et al.
7,580,643	B2	8/2009	Moore et al.	7,783,195	B2	8/2010	Riggsby et al.
7,581,702	B2	9/2009	Wheeler et al.	7,786,894	B2	8/2010	Polk et al.
7,583,074	B1	9/2009	Lynch et al.	7,786,945	B2	8/2010	Baldauf et al.
7,583,233	B2	9/2009	Goldberg et al.	7,786,946	B2	8/2010	Diaz et al.
7,584,470	B2	9/2009	Barker et al.	7,791,549	B2	9/2010	Clymer et al.
7,589,470	B2	9/2009	Oksuz et al.	7,792,016	B2	9/2010	Arai et al.
7,589,630	B2	9/2009	Drake et al.	7,795,877	B2	9/2010	Radtke et al.
7,589,686	B2	9/2009	Balzovsky et al.	7,795,994	B2	9/2010	Radtke et al.
7,590,404	B1	9/2009	Johnson	7,796,025	B2	9/2010	Berkman et al.
7,591,020	B2	9/2009	Kammer et al.	7,796,122	B2	9/2010	Shih et al.
7,591,792	B2	9/2009	Bouton et al.	7,796,890	B1	9/2010	Johnson
7,593,067	B2	9/2009	Taguchi et al.	7,797,367	B1	9/2010	Girod et al.
7,596,222	B2	9/2009	Jonas et al.	7,805,029	B2	9/2010	Bayindir et al.
7,598,844	B2	10/2009	Corcoran et al.	7,808,441	B2	10/2010	Parsche et al.
7,602,333	B2	10/2009	Hiramatsu et al.	7,809,223	B2	10/2010	Miyabe et al.
7,602,815	B2	10/2009	Houghton et al.	7,812,686	B2	10/2010	Woods et al.
7,605,768	B2	10/2009	Ebling et al.	7,812,778	B2	10/2010	Hasegawa et al.
7,620,370	B2	11/2009	Barak et al.	7,813,344	B2	10/2010	Cheswick
7,625,131	B2	12/2009	Zienkewicz et al.	7,817,063	B2	10/2010	Hawkins et al.
7,626,489	B2	12/2009	Berkman et al.	7,825,793	B1	11/2010	Spillman et al.
7,626,542	B2	12/2009	Kober et al.	7,825,867	B2	11/2010	Tuttle et al.
7,627,300	B2	12/2009	Abramov et al.	7,826,602	B1	11/2010	Hunyady et al.
7,633,442	B2	12/2009	Lynch et al.	7,827,610	B2	11/2010	Wang et al.
7,634,250	B1	12/2009	Prasad et al.	7,830,228	B2	11/2010	Evans et al.
7,639,201	B2	12/2009	Marklein et al.	7,835,128	B2	11/2010	Divan et al.
7,640,562	B2	12/2009	Bouilloux-Lafont et al.	7,835,600	B1	11/2010	Yap et al.
7,640,581	B1	12/2009	Brenton et al.	7,843,375	B1	11/2010	Rennie et al.
7,653,363	B2	1/2010	Karr et al.	7,844,081	B2	11/2010	McMakin et al.
RE41,147	E	2/2010	Pang et al.	7,848,517	B2	12/2010	Britz et al.
7,656,167	B1	2/2010	McLean et al.	7,852,752	B2	12/2010	Kano
7,656,358	B2	2/2010	Haziza et al.	7,852,837	B1	12/2010	Au et al.
7,660,244	B2	2/2010	Kadaba et al.	7,853,267	B2	12/2010	Jensen et al.
7,660,252	B1	2/2010	Huang et al.	7,855,612	B2	12/2010	Zienkewicz et al.
7,660,328	B1	2/2010	Oz et al.	7,856,007	B2	12/2010	Corcoran et al.
7,664,117	B2	2/2010	Lou et al.	7,869,391	B2	1/2011	Lee et al.
				7,872,610	B2	1/2011	Motzer et al.
				7,873,249	B2	1/2011	Kachmar et al.
				7,876,174	B2	1/2011	Radtke et al.
				7,884,285	B2	2/2011	Spencer

(56)

References Cited

U.S. PATENT DOCUMENTS

7,884,648 B2	2/2011	Broyde et al.	8,102,779 B2	1/2012	Kim et al.
7,885,542 B2	2/2011	Riggsby et al.	8,106,749 B2	1/2012	Ina et al.
7,889,129 B2	2/2011	Fox et al.	8,106,849 B2	1/2012	Suddath et al.
7,889,148 B2	2/2011	Diaz et al.	RE43,163 E	2/2012	Anderson
7,889,149 B2	2/2011	Peebles et al.	8,111,148 B2	2/2012	Parker et al.
7,890,053 B2	2/2011	Washiro	8,112,649 B2	2/2012	Potkonjak et al.
7,893,789 B2	2/2011	Paynter et al.	8,120,488 B2	2/2012	Bloy et al.
7,894,770 B2	2/2011	Washiro et al.	8,121,624 B2	2/2012	Cai et al.
7,898,480 B2	3/2011	Rebeiz et al.	8,125,282 B2	2/2012	Bao et al.
7,899,403 B2	3/2011	Aaron	8,125,399 B2	2/2012	McKinzie et al.
7,903,918 B1	3/2011	Bickham et al.	8,126,393 B2	2/2012	Wu et al.
7,903,972 B2	3/2011	Riggsby et al.	8,129,817 B2	3/2012	Jou et al.
7,906,973 B1	3/2011	Orr et al.	8,131,125 B2	3/2012	Molin et al.
7,907,097 B2	3/2011	Syed et al.	8,131,266 B2	3/2012	Cai et al.
7,915,980 B2	3/2011	Hardacker et al.	8,132,239 B2	3/2012	Wahl
7,916,081 B2	3/2011	Lakkis et al.	8,134,424 B2	3/2012	Kato et al.
7,928,750 B2	4/2011	Miller et al.	8,134,458 B2	3/2012	Lund
7,929,940 B1	4/2011	Dianda et al.	8,135,050 B1	3/2012	Stadler et al.
7,930,750 B1	4/2011	Gauvin et al.	8,140,113 B2	3/2012	Rofougaran et al.
7,937,699 B2	5/2011	Schneider et al.	8,150,311 B2	4/2012	Hart et al.
7,940,207 B1	5/2011	Kienzle et al.	8,151,306 B2	4/2012	Rakib
7,940,731 B2	5/2011	Gao et al.	8,156,520 B2	4/2012	Casagrande et al.
7,956,818 B1	6/2011	Hsu et al.	8,159,316 B2	4/2012	Miyazato et al.
7,958,120 B2	6/2011	Muntz et al.	8,159,342 B1	4/2012	Medina, III et al.
7,961,710 B2	6/2011	Lee et al.	8,159,385 B2	4/2012	Farneth et al.
7,962,957 B2	6/2011	Keohane et al.	8,159,394 B2	4/2012	Hayes et al.
7,965,842 B2	6/2011	Whelan et al.	8,159,742 B2	4/2012	McKay et al.
7,970,365 B2	6/2011	Martin et al.	8,159,933 B2	4/2012	Henry
7,970,937 B2	6/2011	Shuster et al.	8,159,955 B2	4/2012	Larsson et al.
7,971,053 B2	6/2011	Gibson, Sr. et al.	8,160,064 B2	4/2012	Kokernak et al.
7,973,296 B2	7/2011	Quick et al.	8,160,530 B2	4/2012	Corman et al.
7,974,387 B2	7/2011	Lutz et al.	8,160,825 B1	4/2012	Roe, Jr. et al.
7,983,740 B2	7/2011	Culver et al.	8,164,531 B2	4/2012	Lier et al.
7,986,711 B2	7/2011	Horvath et al.	8,171,146 B2	5/2012	Chen et al.
7,990,146 B2	8/2011	Lazar et al.	8,172,173 B2	5/2012	Carlson et al.
7,990,329 B2	8/2011	Deng et al.	8,173,943 B2	5/2012	Vilo et al.
7,991,877 B2	8/2011	Keohane et al.	8,175,535 B2	5/2012	Mu et al.
7,992,014 B2	8/2011	Langgood et al.	8,175,649 B2	5/2012	Harel et al.
7,994,996 B2	8/2011	Rebeiz et al.	8,179,787 B2	5/2012	Knapp et al.
7,994,999 B2	8/2011	Maeda et al.	8,180,917 B1	5/2012	Yan et al.
7,997,546 B1	8/2011	Andersen et al.	8,184,015 B2	5/2012	Lilien et al.
8,010,116 B2	8/2011	Scheinert	8,184,059 B2	5/2012	Bunch et al.
8,013,694 B2	9/2011	Sagala et al.	8,184,311 B2	5/2012	Sakai et al.
8,019,288 B2	9/2011	Yu et al.	8,185,062 B2	5/2012	Rofougaran et al.
8,022,885 B2	9/2011	Smoyer et al.	8,188,855 B2	5/2012	Sharma et al.
8,022,887 B1	9/2011	Zarnaghi et al.	8,199,762 B2	6/2012	Michelson et al.
8,023,410 B2	9/2011	O'Neill et al.	8,203,501 B2	6/2012	Kim et al.
8,027,391 B2	9/2011	Matsubara et al.	8,212,635 B2	7/2012	Miller, II et al.
8,036,207 B2	10/2011	Chen et al.	8,212,722 B2	7/2012	Ngo et al.
8,049,576 B2	11/2011	Broyde et al.	8,213,758 B2	7/2012	Dong et al.
8,054,199 B2	11/2011	Addy et al.	8,218,929 B2	7/2012	Bickham et al.
8,059,576 B2	11/2011	Vavik et al.	8,222,919 B2	7/2012	Broyde et al.
8,059,593 B2	11/2011	Shih et al.	8,222,977 B2	7/2012	Oyama et al.
8,060,308 B2	11/2011	Breed et al.	8,225,379 B2	7/2012	van de Groenendaal et al.
8,063,832 B1	11/2011	Weller et al.	8,233,905 B2	7/2012	Vaswani et al.
8,064,744 B2	11/2011	Atkins et al.	8,237,617 B1	8/2012	Johnson et al.
8,064,944 B2	11/2011	Yun et al.	8,238,824 B2	8/2012	Washiro
8,065,099 B2	11/2011	Gibala et al.	8,238,840 B2	8/2012	Iio et al.
8,069,483 B1	11/2011	Matlock et al.	8,242,358 B2	8/2012	Park et al.
8,072,323 B2	12/2011	Kodama et al.	8,243,603 B2	8/2012	Gossain et al.
8,072,386 B2	12/2011	Lier et al.	8,249,028 B2	8/2012	Porras et al.
8,073,810 B2	12/2011	Maes	8,251,307 B2	8/2012	Goossen et al.
8,077,049 B2	12/2011	Yaney et al.	8,253,516 B2	8/2012	Miller, II et al.
8,077,113 B2	12/2011	Renilson et al.	8,255,952 B2	8/2012	Boylan, III et al.
8,081,854 B2	12/2011	Yoon et al.	8,258,743 B2	9/2012	Tyler et al.
8,089,356 B2	1/2012	Moore et al.	8,259,028 B2	9/2012	Hills et al.
8,089,404 B2	1/2012	Nichols et al.	8,264,417 B2	9/2012	Snow et al.
8,089,952 B2	1/2012	Spade et al.	8,269,583 B2	9/2012	Miller, II et al.
8,090,258 B2	1/2012	DeLew et al.	8,284,102 B2	10/2012	Hayes et al.
8,090,379 B2	1/2012	Lambert et al.	8,287,323 B2	10/2012	Kiesow et al.
8,094,081 B1	1/2012	Bruzzi et al.	8,295,301 B2	10/2012	Yonge, III et al.
8,094,985 B2	1/2012	Imamura et al.	8,300,538 B2	10/2012	Kim et al.
8,095,093 B2	1/2012	Takinami et al.	8,300,640 B2	10/2012	Al-Banna et al.
8,098,198 B2	1/2012	Thiesen et al.	8,316,228 B2	11/2012	Winslow et al.
8,102,324 B2	1/2012	Tuau et al.	8,316,364 B2	11/2012	Stein et al.
			8,324,990 B2	12/2012	Vouloumanos
			8,325,034 B2	12/2012	Moore et al.
			8,325,636 B2	12/2012	Binder
			8,325,693 B2	12/2012	Binder et al.

(56)

References Cited

U.S. PATENT DOCUMENTS

8,330,259	B2	12/2012	Soler et al.	8,582,502	B2	11/2013	Conte et al.
8,335,596	B2	12/2012	Raman et al.	8,584,195	B2	11/2013	Sherlock et al.
8,343,145	B2	1/2013	Brannan et al.	8,587,490	B2	11/2013	Niver et al.
8,344,829	B2	1/2013	Miller, II et al.	8,587,492	B2	11/2013	Runyon et al.
8,354,970	B2	1/2013	Armbrecht et al.	8,588,567	B2	11/2013	Kamps et al.
8,359,124	B2	1/2013	Zhou et al.	8,588,840	B2	11/2013	Truong et al.
8,362,775	B2	1/2013	Speckner et al.	8,588,991	B1	11/2013	Forbes, Jr.
8,363,313	B2	1/2013	Nakaguma et al.	8,593,238	B2	11/2013	Miller, II et al.
8,369,667	B2	2/2013	Rose et al.	8,594,956	B2	11/2013	McBee et al.
8,373,095	B2	2/2013	Huynh et al.	8,595,141	B2	11/2013	Hao et al.
8,373,597	B2	2/2013	Schadler et al.	8,599,150	B2	12/2013	Phillipp
8,374,821	B2	2/2013	Rousselle et al.	8,600,602	B1	12/2013	Watson et al.
8,384,600	B2	2/2013	Huang et al.	8,604,982	B2	12/2013	Gummalla et al.
8,385,978	B2	2/2013	Leung et al.	8,604,999	B2	12/2013	Abumrad et al.
8,386,198	B2	2/2013	Lancaster	8,605,361	B2	12/2013	Batchko et al.
8,390,307	B2	3/2013	Slupsky et al.	8,605,579	B2	12/2013	Abraham et al.
8,390,402	B2	3/2013	Kunes et al.	8,612,550	B2	12/2013	Yoo et al.
8,405,567	B2	3/2013	Park et al.	8,613,020	B2	12/2013	Knudson et al.
8,406,239	B2	3/2013	Hurwitz et al.	8,615,190	B2	12/2013	Lu
8,406,593	B2	3/2013	Molin et al.	8,625,547	B1	1/2014	Miller et al.
8,407,687	B2	3/2013	Moshir et al.	8,629,811	B2	1/2014	Gaynor et al.
8,412,130	B2	4/2013	Suematsu et al.	8,639,260	B2	1/2014	Fox et al.
8,414,326	B2	4/2013	Bowman	8,639,390	B2	1/2014	Tamarkin et al.
8,415,884	B2	4/2013	Chen et al.	8,639,934	B2	1/2014	Kruglick
8,428,033	B2	4/2013	Hettstedt et al.	8,644,219	B2	2/2014	Nishizaka et al.
8,433,168	B2	4/2013	Filippov et al.	8,653,906	B2	2/2014	Mahon et al.
8,434,103	B2	4/2013	Tsuchida et al.	8,655,396	B2	2/2014	Malladi et al.
8,437,383	B2	5/2013	Wiwel et al.	8,656,458	B2	2/2014	Heffez et al.
8,452,555	B2	5/2013	Hayward et al.	8,660,526	B1	2/2014	Heiderscheit et al.
8,457,027	B2	6/2013	Dougherty et al.	8,660,698	B2	2/2014	Phillips et al.
8,458,453	B1	6/2013	Mahalingaiah et al.	8,665,102	B2	3/2014	Salewske et al.
8,462,063	B2	6/2013	Gummalla et al.	8,666,553	B2	3/2014	Phillips et al.
8,467,363	B2	6/2013	Lea et al.	8,670,946	B2	3/2014	Salazar et al.
8,468,244	B2	6/2013	Redlich et al.	8,674,630	B1	3/2014	Cornelius et al.
8,471,513	B2	6/2013	Han	8,676,186	B2	3/2014	Niu
8,472,327	B2	6/2013	DelRegno et al.	8,680,450	B2	3/2014	Pritchard et al.
8,484,137	B2	7/2013	Johnson et al.	8,680,706	B2	3/2014	Zyren et al.
8,484,511	B2	7/2013	Tidwell et al.	8,681,463	B2	3/2014	Franks et al.
8,495,718	B2	7/2013	Han et al.	8,686,911	B2	4/2014	Kim et al.
8,497,749	B2	7/2013	Elmore	8,687,650	B2	4/2014	King
8,503,845	B2	8/2013	Winzer et al.	8,688,153	B2	4/2014	Komori et al.
8,504,135	B2	8/2013	Bourqui et al.	8,699,454	B2	4/2014	Hapsari et al.
8,505,057	B2	8/2013	Rogers	8,699,461	B2	4/2014	Qian et al.
8,509,114	B1	8/2013	Szajdecki	8,705,925	B2	4/2014	Terada et al.
8,514,980	B2	8/2013	Kuhtz	8,706,026	B2	4/2014	Truong et al.
8,515,383	B2	8/2013	Prince et al.	8,707,432	B1	4/2014	Rathi et al.
8,516,129	B1	8/2013	Skene et al.	8,711,538	B2	4/2014	Woodworth et al.
8,516,470	B1	8/2013	Joshi et al.	8,711,732	B2	4/2014	Johnson et al.
8,516,474	B2	8/2013	Lamba et al.	8,711,806	B2	4/2014	Lim et al.
8,519,892	B2	8/2013	Ding et al.	8,711,857	B2	4/2014	Jackson et al.
8,520,578	B2	8/2013	Rayment et al.	8,712,200	B1	4/2014	Abernathy et al.
8,520,636	B2	8/2013	Xu	8,719,938	B2	5/2014	Demeter et al.
8,528,059	B1	9/2013	Saluzzo et al.	8,723,730	B2	5/2014	Lu et al.
8,532,023	B2	9/2013	Buddhikot et al.	8,724,102	B2	5/2014	Urban
8,532,046	B2	9/2013	Hu et al.	8,729,857	B2	5/2014	Stählin et al.
8,532,492	B2	9/2013	Sadowski et al.	8,731,358	B2	5/2014	Pare et al.
8,536,857	B2	9/2013	Nero, Jr. et al.	8,732,476	B1	5/2014	Van et al.
8,537,068	B2	9/2013	Call et al.	8,736,502	B1	5/2014	Mehr et al.
8,537,705	B2	9/2013	Afkhamie et al.	8,737,793	B2	5/2014	Imamura et al.
8,538,428	B2	9/2013	Bartlett et al.	8,738,318	B2	5/2014	Spillane
8,539,540	B2	9/2013	Zenoni	8,742,997	B2	6/2014	McPeak et al.
8,539,569	B2	9/2013	Mansour	8,743,004	B2	6/2014	Haziza
8,542,968	B2	9/2013	Dong et al.	8,749,449	B2	6/2014	Caldwell et al.
8,545,322	B2	10/2013	George et al.	8,750,097	B2	6/2014	Maenpaa et al.
8,548,294	B2	10/2013	Toge et al.	8,750,664	B2	6/2014	Huang et al.
8,553,646	B2	10/2013	Kumar	8,754,852	B2	6/2014	Lee et al.
8,561,104	B1	10/2013	Dow et al.	8,755,659	B2	6/2014	Imamura et al.
8,561,181	B1	10/2013	Sobel et al.	8,760,354	B2	6/2014	Flannery et al.
8,565,568	B2	10/2013	Bigot-Astruc et al.	8,761,792	B2	6/2014	Sennett et al.
8,566,058	B2	10/2013	Pupalaikis et al.	8,763,097	B2	6/2014	Bhatnagar et al.
8,572,247	B2	10/2013	Larson et al.	8,766,657	B2	7/2014	DeJean et al.
8,572,639	B2	10/2013	Ficco	8,767,071	B1	7/2014	Marshall
8,572,661	B2	10/2013	Strong et al.	8,769,622	B2	7/2014	Chang et al.
8,578,076	B2	11/2013	van der Linden et al.	8,773,312	B1	7/2014	Diaz et al.
8,578,486	B2	11/2013	Lifiand et al.	8,780,012	B2	7/2014	Llombart Juan et al.
				8,782,195	B2	7/2014	Foti
				8,786,284	B2	7/2014	Sirigiri et al.
				8,786,514	B2	7/2014	Dickie et al.
				8,789,091	B2	7/2014	Eldering et al.

(56)

References Cited

U.S. PATENT DOCUMENTS

8,792,760 B2	7/2014	Choi et al.	8,958,812 B2	2/2015	Weiguo
8,792,933 B2	7/2014	Chen et al.	8,963,424 B1	2/2015	Neilson et al.
8,793,363 B2	7/2014	Sater et al.	8,963,790 B2	2/2015	Brown et al.
8,793,742 B2	7/2014	Macrae et al.	8,964,433 B2	2/2015	Hai-Maharsi
8,797,207 B2	8/2014	Kienzle et al.	8,966,609 B2	2/2015	Lee et al.
8,804,667 B2	8/2014	Wang	8,968,287 B2	3/2015	Shroff et al.
8,806,202 B2	8/2014	Shoemake et al.	8,970,438 B2	3/2015	Hager et al.
8,810,404 B2	8/2014	Bertoncini et al.	8,984,113 B2	3/2015	Li et al.
8,810,421 B2	8/2014	Deaver, Sr. et al.	8,989,788 B2	3/2015	Kim et al.
8,810,468 B2	8/2014	Cannon et al.	8,994,473 B2	3/2015	Levi et al.
8,811,278 B2	8/2014	Hori et al.	8,994,474 B2	3/2015	Mahon et al.
8,811,912 B2	8/2014	Austin et al.	8,996,188 B2	3/2015	Frader-thompson et al.
8,812,050 B1	8/2014	Bencheikh et al.	8,996,728 B2	3/2015	Cochinwala et al.
8,812,154 B2	8/2014	Vian et al.	9,000,353 B2	4/2015	Seo et al.
8,817,741 B2	8/2014	Shaheen	9,001,689 B1	4/2015	Ponnampalam et al.
8,824,380 B2	9/2014	Jetcheva et al.	9,001,717 B2	4/2015	Chun et al.
8,825,239 B2	9/2014	Cooper et al.	9,003,492 B2	4/2015	Katar
8,829,934 B2	9/2014	Sellathamby et al.	9,008,208 B2	4/2015	Khandani
8,830,112 B1	9/2014	Buehler et al.	9,008,513 B2	4/2015	Kim et al.
8,831,506 B2	9/2014	Claret et al.	9,009,460 B2	4/2015	Chen
8,836,503 B2	9/2014	Girod et al.	9,013,361 B1	4/2015	Lam et al.
8,836,607 B2	9/2014	Cook et al.	9,014,621 B2	4/2015	Mohebbi
8,839,350 B1	9/2014	Shapcott et al.	9,015,467 B2	4/2015	Buer
8,847,840 B1	9/2014	Diaz et al.	9,019,164 B2	4/2015	Syed et al.
8,847,846 B1	9/2014	Diaz et al.	9,019,595 B2	4/2015	Jain et al.
8,856,239 B1	10/2014	Oliver et al.	9,019,846 B2	4/2015	Shetty et al.
8,856,530 B2	10/2014	Lamberg et al.	9,019,892 B2	4/2015	Zhou et al.
8,863,245 B1	10/2014	Abhyanker	9,020,555 B2	4/2015	Sheikh et al.
8,866,691 B2	10/2014	Montgomery et al.	9,021,251 B2	4/2015	Chawla
8,866,695 B2	10/2014	Jefferson et al.	9,021,575 B2	4/2015	Martini
8,867,226 B2	10/2014	Colomb et al.	RE45,514 E	5/2015	Brown
8,872,032 B2	10/2014	Su et al.	9,024,831 B2	5/2015	Wang et al.
8,875,224 B2	10/2014	Gross et al.	9,031,725 B1	5/2015	Diesposti et al.
8,878,740 B2	11/2014	Coupland et al.	9,037,516 B2	5/2015	Abhyanker
8,880,765 B2	11/2014	Seal et al.	9,042,245 B2	5/2015	Tzannes et al.
8,881,588 B2	11/2014	Baer et al.	9,042,812 B1	5/2015	Bennett et al.
8,885,689 B2	11/2014	Blasco et al.	9,065,172 B2	6/2015	Lewry et al.
8,886,229 B2	11/2014	Agrawal et al.	9,065,177 B2	6/2015	Alexopoulos
8,887,212 B2	11/2014	Dua	9,066,224 B2	6/2015	Schwengler
8,890,759 B2	11/2014	Pantea et al.	9,070,962 B2	6/2015	Kobayashi
8,893,246 B2	11/2014	El-Moussa et al.	9,070,964 B1	6/2015	Schuss et al.
8,897,215 B2	11/2014	Hazani et al.	9,079,349 B2	7/2015	Slafer
8,897,499 B2	11/2014	Rekimoto	9,082,307 B2	7/2015	Sharawi
8,897,695 B2	11/2014	Becker et al.	9,083,083 B2	7/2015	Hills et al.
8,897,697 B1	11/2014	Bennett et al.	9,083,425 B1	7/2015	Moussouris et al.
8,901,916 B2	12/2014	Rodriguez et al.	9,083,581 B1	7/2015	Addepalli et al.
8,903,214 B2	12/2014	Alkeskjold	9,084,124 B2	7/2015	Nickel et al.
8,907,222 B2	12/2014	Stransky	9,092,962 B1	7/2015	Merrill et al.
8,907,845 B2	12/2014	Jones	9,092,963 B2	7/2015	Fetzer et al.
8,908,502 B2	12/2014	Hayashitani	9,094,407 B1	7/2015	Mathieu
8,908,573 B1	12/2014	Wang et al.	9,094,840 B2	7/2015	Liu et al.
8,913,862 B1	12/2014	Emmerich et al.	9,098,325 B2	8/2015	Reddin
8,917,210 B2	12/2014	Shamim et al.	9,099,787 B2	8/2015	Blech
8,917,215 B2	12/2014	Pohl	9,103,864 B2	8/2015	Ali
8,917,964 B2	12/2014	Blew et al.	9,105,981 B2	8/2015	Syed
8,918,108 B2	12/2014	Van Heeswyk et al.	9,106,617 B2	8/2015	Kshirsagar et al.
8,918,135 B2	12/2014	Kang et al.	9,112,281 B2	8/2015	Bresciani et al.
8,922,447 B2	12/2014	Gao et al.	9,113,347 B2	8/2015	Henry
8,925,079 B2	12/2014	Miyake et al.	9,119,127 B1	8/2015	Henry
8,929,841 B2	1/2015	Rofougaran et al.	9,119,179 B1	8/2015	Firoiu et al.
8,934,747 B2	1/2015	Smith et al.	9,128,941 B2	9/2015	Shulman
8,937,577 B2	1/2015	Gerini et al.	9,130,641 B2	9/2015	Mohebbi
8,938,144 B2	1/2015	Hennink et al.	9,134,945 B2	9/2015	Husain
8,938,255 B2	1/2015	Dalla Torre et al.	9,137,485 B2	9/2015	Bar-Niv et al.
8,941,912 B2	1/2015	Ichii et al.	9,142,334 B2	9/2015	Muto et al.
8,947,258 B2	2/2015	Reid et al.	9,143,084 B2	9/2015	Perez et al.
8,948,235 B2	2/2015	Proctor, Jr. et al.	9,143,196 B2	9/2015	Schwengler
8,948,690 B2	2/2015	Duerksen et al.	9,154,641 B2	10/2015	Shaw
8,952,678 B2	2/2015	Giboney et al.	9,157,954 B2	10/2015	Nickel
8,955,051 B2	2/2015	Marzii	9,158,418 B2	10/2015	Oda et al.
8,955,075 B2	2/2015	Smith et al.	9,158,427 B1	10/2015	Wang
8,957,818 B2	2/2015	Chen et al.	9,167,535 B2	10/2015	Christoffersson et al.
8,957,821 B1	2/2015	Matyas et al.	9,171,458 B2	10/2015	Salter
8,958,356 B2	2/2015	Lu et al.	9,173,217 B2	10/2015	Teng et al.
8,958,665 B2	2/2015	Ziari et al.	9,178,282 B2	11/2015	Mittleman et al.
			9,194,930 B2	11/2015	Pupalaikis
			9,219,594 B2	11/2015	Khlat
			9,201,556 B2	12/2015	Free et al.
			9,202,371 B2	12/2015	Jain

(56)

References Cited

U.S. PATENT DOCUMENTS

9,203,149	B2	12/2015	Henderson et al.	9,465,397	B2	10/2016	Forbes, Jr. et al.
9,204,418	B2	12/2015	Siomina et al.	9,467,219	B2	10/2016	Vilhar
9,207,168	B2	12/2015	Lovely et al.	9,467,870	B2	10/2016	Bennett
9,209,902	B2	12/2015	Willis, III et al.	9,476,932	B2	10/2016	Furse et al.
9,210,192	B1	12/2015	Pathuri et al.	9,478,865	B1	10/2016	Willis et al.
9,210,586	B2	12/2015	Catovic et al.	9,479,241	B2	10/2016	Pabla
9,219,307	B2	12/2015	Takahashi et al.	9,479,266	B2	10/2016	Henry et al.
9,225,396	B2	12/2015	Maltsev et al.	9,479,299	B2	10/2016	Kim et al.
9,240,835	B2	1/2016	Cune et al.	9,479,392	B2	10/2016	Anderson et al.
9,244,117	B2	1/2016	Khan et al.	9,479,535	B2	10/2016	Cohen et al.
9,246,231	B2	1/2016	Ju	9,490,869	B1	11/2016	Henry
9,246,334	B2	1/2016	Lo et al.	9,490,913	B2	11/2016	Berlin
9,253,588	B2	2/2016	Schmidt et al.	9,495,037	B2	11/2016	King-Smith
9,260,244	B1	2/2016	Cohn	9,496,921	B1	11/2016	Corum
9,264,204	B2	2/2016	Seo et al.	9,497,572	B2	11/2016	Britt et al.
9,265,078	B2	2/2016	Lim et al.	9,503,170	B2	11/2016	Vu
9,270,013	B2	2/2016	Ley	9,503,189	B2	11/2016	Henry et al.
9,271,185	B2	2/2016	Abdelmonem et al.	9,509,415	B1	11/2016	Henry et al.
9,276,303	B2	3/2016	Chang et al.	9,510,203	B2	11/2016	Jactat et al.
9,276,304	B2	3/2016	Behan	9,515,367	B2	12/2016	Herbsommer et al.
9,277,331	B2	3/2016	Chao et al.	9,577,306	B2*	2/2017	Henry H04B 10/25752
9,281,564	B2	3/2016	Vincent	2001/0030789	A1	10/2001	Jiang et al.
9,282,144	B2	3/2016	Tebay et al.	2002/0002040	A1	1/2002	Kline et al.
9,285,461	B2	3/2016	Townley et al.	2002/0008672	A1	1/2002	Gothard et al.
9,287,605	B2	3/2016	Daughenbaugh et al.	2002/0011960	A1	1/2002	Yuanzhu et al.
9,288,844	B1	3/2016	Akhavan-saraf et al.	2002/0021716	A1	2/2002	Terk et al.
9,289,177	B2	3/2016	Samsudin et al.	2002/0024424	A1	2/2002	Burns et al.
9,293,798	B2	3/2016	Ye	2002/0027481	A1	3/2002	Fiedziuszko et al.
9,293,801	B2	3/2016	Courtney et al.	2002/0040439	A1	4/2002	Kellum et al.
9,302,770	B2	4/2016	Cohen et al.	2002/0057223	A1	5/2002	Hook
9,306,682	B2	4/2016	Singh	2002/0061217	A1	5/2002	Hillman et al.
9,312,919	B1	4/2016	Barzegar et al.	2002/0069417	A1	6/2002	Kliger et al.
9,312,929	B2	4/2016	Forenza et al.	2002/0083194	A1	6/2002	Bak et al.
9,315,663	B2	4/2016	Appleby	2002/0091807	A1	7/2002	Goodman et al.
9,319,311	B2	4/2016	Wang et al.	2002/0099949	A1	7/2002	Fries et al.
9,324,020	B2	4/2016	Nazarov	2002/0101852	A1	8/2002	Say et al.
9,325,067	B2	4/2016	Ali et al.	2002/0111997	A1	8/2002	Herlihy et al.
9,325,516	B2	4/2016	Frei et al.	2002/0156917	A1	10/2002	Nye et al.
9,326,316	B2	4/2016	Yonge et al.	2002/0186694	A1	12/2002	Mahajan et al.
9,334,052	B2	5/2016	Ubhi et al.	2002/0197979	A1	12/2002	Vanderveen et al.
9,338,823	B2	5/2016	Saban et al.	2003/0002125	A1	1/2003	Fuse et al.
9,346,560	B2	5/2016	Wang	2003/0002476	A1	1/2003	Chung et al.
9,350,063	B2	5/2016	Herbsommer et al.	2003/0010528	A1	1/2003	Niles
9,351,182	B2	5/2016	Elliott et al.	2003/0022694	A1	1/2003	Olsen et al.
9,356,358	B2	5/2016	Hu et al.	2003/0038753	A1	2/2003	Mahon et al.
9,362,629	B2	6/2016	Miller et al.	2003/0049003	A1	3/2003	Ahmad et al.
9,363,333	B2	6/2016	Basso et al.	2003/0054793	A1	3/2003	Manis et al.
9,363,690	B1	6/2016	Suthar et al.	2003/0054811	A1	3/2003	Han et al.
9,363,761	B2	6/2016	Venkatraman	2003/0061346	A1	3/2003	Pekary et al.
9,366,743	B2	6/2016	Doshi et al.	2003/0094976	A1	5/2003	Miyashita
9,368,275	B2	6/2016	McBee et al.	2003/0095208	A1	5/2003	Chouraqui et al.
9,369,177	B2	6/2016	Hui et al.	2003/0137464	A1	7/2003	Foti et al.
9,372,228	B2	6/2016	Gavin et al.	2003/0152331	A1	8/2003	Dair et al.
9,379,527	B2	6/2016	Jean et al.	2003/0164794	A1	9/2003	Haynes et al.
9,379,556	B2	7/2016	Haensgen et al.	2003/0188308	A1	10/2003	Kizuka
9,380,857	B2	7/2016	Davis et al.	2003/0190110	A1	10/2003	Kline et al.
9,391,874	B2	7/2016	Corti et al.	2003/0202756	A1	10/2003	Hurley et al.
9,393,683	B2	7/2016	Kimberlin et al.	2003/0210197	A1	11/2003	Cencich et al.
9,394,716	B2	7/2016	Butler et al.	2003/0224784	A1	12/2003	Hunt et al.
9,397,380	B2	7/2016	Kudela et al.	2004/0015725	A1	1/2004	Boneh et al.
9,401,863	B2	7/2016	Hui et al.	2004/0023640	A1	2/2004	Ballai et al.
9,404,750	B2	8/2016	Rios et al.	2004/0024913	A1	2/2004	Ikeda et al.
9,413,519	B2	8/2016	Khoshnood et al.	2004/0048596	A1	3/2004	Wyrzykowska et al.
9,414,126	B1	8/2016	Zinevich	2004/0054425	A1	3/2004	Elmore
9,417,731	B2	8/2016	Premont et al.	2004/0084582	A1	5/2004	Kralic et al.
9,419,712	B2	8/2016	Heidler	2004/0085153	A1	5/2004	Fukunaga et al.
9,421,869	B1	8/2016	Ananthanarayanan et al.	2004/0090312	A1	5/2004	Manis et al.
9,422,139	B1	8/2016	Bialkowski et al.	2004/0091032	A1	5/2004	Duchi et al.
9,432,478	B2	8/2016	Gibbon et al.	2004/0100343	A1	5/2004	Tsu et al.
9,432,865	B1	8/2016	Jadunandan et al.	2004/0104410	A1	6/2004	Gilbert et al.
9,439,092	B1	9/2016	Chukka et al.	2004/0113756	A1	6/2004	Mollenkopf et al.
9,443,417	B2	9/2016	Wang	2004/0113757	A1	6/2004	White, II et al.
9,458,974	B2	10/2016	Townsend, Jr.	2004/0119564	A1	6/2004	Itoh et al.
9,459,746	B2	10/2016	Zarraga et al.	2004/0131310	A1	7/2004	Walker et al.
9,461,706	B1	10/2016	Bennett et al.	2004/0163135	A1	8/2004	Giaccherini et al.
				2004/0165669	A1	8/2004	Otsuka et al.
				2004/0169572	A1	9/2004	Elmore et al.
				2004/0196784	A1	10/2004	Larsson et al.
				2004/0198228	A1	10/2004	Raghothaman et al.

(56)

References Cited

U.S. PATENT DOCUMENTS

2004/0212481	A1	10/2004	Abraham et al.	2007/0090185	A1	4/2007	Lewkowitz et al.
2004/0213147	A1	10/2004	Wiese et al.	2007/0105508	A1	5/2007	Tong et al.
2004/0213189	A1	10/2004	Alsbaugh et al.	2007/0135044	A1	6/2007	Rhodes et al.
2004/0213294	A1	10/2004	Hughes et al.	2007/0144779	A1	6/2007	Vicente et al.
2004/0242185	A1	12/2004	Lee et al.	2007/0164908	A1	7/2007	Turchinets et al.
2004/0250069	A1	12/2004	Kosamo et al.	2007/0189182	A1	8/2007	Berkman et al.
2005/0002408	A1	1/2005	Lee et al.	2007/0201540	A1	8/2007	Berkman et al.
2005/0005854	A1	1/2005	Suzuki et al.	2007/0202913	A1	8/2007	Ban et al.
2005/0017825	A1	1/2005	Hansen	2007/0211689	A1	9/2007	Campero et al.
2005/0031267	A1	2/2005	Sumimoto et al.	2007/0211786	A1	9/2007	Shattil et al.
2005/0063422	A1	3/2005	Lazar et al.	2007/0216596	A1	9/2007	Lewis et al.
2005/0068223	A1	3/2005	Vavik et al.	2007/0223381	A1	9/2007	Radtke et al.
2005/0069321	A1	3/2005	Sullivan et al.	2007/0226779	A1	9/2007	Yokomitsu et al.
2005/0074208	A1	4/2005	Badcock et al.	2007/0229184	A1	10/2007	Liu et al.
2005/0097396	A1	5/2005	Wood	2007/0229231	A1	10/2007	Hurwitz et al.
2005/0102185	A1	5/2005	Barker et al.	2007/0252998	A1	11/2007	Berthold et al.
2005/0111533	A1	5/2005	Berkman et al.	2007/0257858	A1	11/2007	Liu et al.
2005/0141808	A1	6/2005	Cheben et al.	2007/0258484	A1	11/2007	Tolaio et al.
2005/0143868	A1	6/2005	Whelan et al.	2007/0268124	A1	11/2007	Berkman et al.
2005/0151659	A1	7/2005	Donovan et al.	2007/0268846	A1	11/2007	Proctor et al.
2005/0159187	A1	7/2005	Mendolia et al.	2007/0300280	A1	12/2007	Turner et al.
2005/0164666	A1	7/2005	Lang et al.	2008/0002652	A1	1/2008	Gupta et al.
2005/0168326	A1	8/2005	White et al.	2008/0003872	A1	1/2008	Chen et al.
2005/0169056	A1	8/2005	Berkman et al.	2008/0007416	A1	1/2008	Cern et al.
2005/0169401	A1	8/2005	Abraham et al.	2008/0008116	A1	1/2008	Buga et al.
2005/0177463	A1	8/2005	Crutchfield et al.	2008/0043655	A1	2/2008	Lee et al.
2005/0190101	A1	9/2005	Hiramatsu et al.	2008/0055149	A1	3/2008	Rees et al.
2005/0208949	A1	9/2005	Chiueh et al.	2008/0060832	A1	3/2008	Razavi et al.
2005/0212626	A1	9/2005	Takamatsu et al.	2008/0064331	A1	3/2008	Washiro et al.
2005/0219126	A1	10/2005	Rebeiz et al.	2008/0077336	A1	3/2008	Fernandes et al.
2005/0219135	A1	10/2005	Lee et al.	2008/0080389	A1	4/2008	Hart et al.
2005/0220180	A1	10/2005	Barlev	2008/0084937	A1	4/2008	Barthold et al.
2005/0226353	A1	10/2005	Gebara et al.	2008/0094298	A1	4/2008	Kralovec et al.
2005/0249245	A1	11/2005	Hazani et al.	2008/0120667	A1	5/2008	Zaltsman
2005/0258920	A1	11/2005	Elmore	2008/0122723	A1	5/2008	Rofougaran et al.
2006/0034724	A1	2/2006	Hamano et al.	2008/0130639	A1	6/2008	Costa-Requena et al.
2006/0038660	A1	2/2006	Doumuki et al.	2008/0143491	A1	6/2008	Deaver et al.
2006/0053486	A1	3/2006	Wesinger et al.	2008/0150790	A1	6/2008	Voigtlaender et al.
2006/0071776	A1	4/2006	White et al.	2008/0153416	A1	6/2008	Washiro et al.
2006/0077906	A1	4/2006	Maegawa et al.	2008/0177678	A1	7/2008	Di Martini et al.
2006/0082516	A1	4/2006	Strickland et al.	2008/0191851	A1	8/2008	Koga et al.
2006/0085813	A1	4/2006	Giraldin et al.	2008/0211727	A1	9/2008	Elmore et al.
2006/0094439	A1	5/2006	Christian et al.	2008/0247716	A1	10/2008	Thomas et al.
2006/0106741	A1	5/2006	Janarthanan et al.	2008/0252522	A1	10/2008	Asbridge et al.
2006/0111047	A1	5/2006	Louberg et al.	2008/0253723	A1	10/2008	Stokes et al.
2006/0113425	A1	6/2006	Rader et al.	2008/0255782	A1	10/2008	Bilac et al.
2006/0114925	A1	6/2006	Gerszberg et al.	2008/0258993	A1	10/2008	Gummalla et al.
2006/0119528	A1	6/2006	Bhattacharyya et al.	2008/0266060	A1	10/2008	Takei et al.
2006/0120399	A1	6/2006	Claret et al.	2008/0267076	A1	10/2008	Laperi et al.
2006/0128322	A1	6/2006	Igarashi et al.	2008/0279199	A1	11/2008	Park et al.
2006/0132380	A1	6/2006	Imai et al.	2008/0280574	A1	11/2008	Rofougaran et al.
2006/0153878	A1	7/2006	Savarino et al.	2008/0313691	A1	12/2008	Cholas
2006/0172781	A1	8/2006	Mohebbi et al.	2009/0002137	A1	1/2009	Radtke et al.
2006/0176124	A1	8/2006	Mansour et al.	2009/0007189	A1	1/2009	Gutknecht
2006/0181394	A1	8/2006	Clarke et al.	2009/0007190	A1	1/2009	Weber et al.
2006/0187023	A1	8/2006	Iwamura et al.	2009/0007194	A1	1/2009	Brady, Jr. et al.
2006/0192672	A1	8/2006	Gidge et al.	2009/0009408	A1	1/2009	Rofougaran et al.
2006/0220833	A1	10/2006	Berkman et al.	2009/0015239	A1	1/2009	Georgiou et al.
2006/0221995	A1	10/2006	Berkman et al.	2009/0054056	A1	2/2009	Gil et al.
2006/0232493	A1	10/2006	Huang et al.	2009/0054737	A1	2/2009	Magar et al.
2006/0238347	A1	10/2006	Parkinson et al.	2009/0061940	A1	3/2009	Scheinert et al.
2006/0239501	A1	10/2006	Petrovic et al.	2009/0067441	A1	3/2009	Ansari et al.
2006/0244672	A1	11/2006	Avakian et al.	2009/0079660	A1	3/2009	Elmore
2006/0249622	A1	11/2006	Steele et al.	2009/0085726	A1	4/2009	Radtke et al.
2006/0255930	A1	11/2006	Berkman et al.	2009/0088907	A1	4/2009	Lewis et al.
2006/0286927	A1	12/2006	Berkman et al.	2009/0093267	A1	4/2009	Ariyur et al.
2007/0002771	A1	1/2007	Berkman et al.	2009/0109981	A1	4/2009	Keselman
2007/0022475	A1	1/2007	Rossi et al.	2009/0125351	A1	5/2009	Davis, Jr. et al.
2007/0025265	A1	2/2007	Marcotullio et al.	2009/0129301	A1	5/2009	Belimpasakis et al.
2007/0025386	A1	2/2007	Riedel et al.	2009/0135848	A1	5/2009	Chan et al.
2007/0040628	A1	2/2007	Kanno et al.	2009/0138931	A1	5/2009	Lin et al.
2007/0041464	A1	2/2007	Kim et al.	2009/0140852	A1	6/2009	Stolarczyk et al.
2007/0041554	A1	2/2007	Newman	2009/0144417	A1	6/2009	Kisel et al.
2007/0054622	A1	3/2007	Berkman	2009/0171780	A1	7/2009	Aldrey et al.
2007/0063914	A1	3/2007	Becker et al.	2009/0175195	A1	7/2009	Macauley et al.
				2009/0181664	A1	7/2009	Kuruvilla et al.
				2009/0201133	A1	8/2009	Bruns et al.
				2009/0202020	A1	8/2009	Hafeez et al.
				2009/0210901	A1	8/2009	Hawkins et al.

(56)

References Cited

U.S. PATENT DOCUMENTS

2009/0212938	A1	8/2009	Swaim et al.	2011/0143673	A1	6/2011	Landesman et al.
2009/0250449	A1	10/2009	Petrenko et al.	2011/0148578	A1	6/2011	Aloi et al.
2009/0254971	A1	10/2009	Herz et al.	2011/0148687	A1	6/2011	Wright et al.
2009/0258652	A1	10/2009	Lambert et al.	2011/0164514	A1	7/2011	Afkhamie et al.
2009/0284435	A1	11/2009	Elmore et al.	2011/0165847	A1	7/2011	Kawasaki et al.
2009/0286482	A1	11/2009	Gorokhov et al.	2011/0169336	A1	7/2011	Yerazunis et al.
2009/0311960	A1	12/2009	Farahani et al.	2011/0172000	A1	7/2011	Quigley et al.
2009/0315668	A1	12/2009	Leete, III et al.	2011/0173447	A1	7/2011	Zhang et al.
2009/0320058	A1	12/2009	Wehmeyer et al.	2011/0187578	A1	8/2011	Farneth et al.
2009/0325479	A1	12/2009	Chakrabarti et al.	2011/0199265	A1	8/2011	Lin et al.
2009/0325628	A1	12/2009	Becker et al.	2011/0208450	A1	8/2011	Salka et al.
2010/0002618	A1	1/2010	Eichinger et al.	2011/0214176	A1	9/2011	Burch et al.
2010/0002731	A1	1/2010	Kimura et al.	2011/0219402	A1	9/2011	Candelore et al.
2010/0013696	A1	1/2010	Schmitt et al.	2011/0220394	A1	9/2011	Szylakowski et al.
2010/0026607	A1	2/2010	Lmai et al.	2011/0225046	A1	9/2011	Eldering et al.
2010/0039339	A1	2/2010	Kuroda et al.	2011/0228814	A1	9/2011	Washiro et al.
2010/0045447	A1	2/2010	Mollenkopf et al.	2011/0235536	A1	9/2011	Nishizaka et al.
2010/0052799	A1	3/2010	Watanabe et al.	2011/0268085	A1	11/2011	Barany et al.
2010/0053019	A1	3/2010	Ikawa et al.	2011/0274396	A1	11/2011	Nakajima et al.
2010/0057894	A1	3/2010	Glasser	2011/0286506	A1	11/2011	Libby et al.
2010/0080203	A1	4/2010	Reynolds et al.	2011/0291878	A1	12/2011	McLaughlin et al.
2010/0085036	A1	4/2010	Banting et al.	2011/0294509	A1	12/2011	Kim et al.
2010/0090887	A1	4/2010	Cooper et al.	2011/0311231	A1	12/2011	Ridgway et al.
2010/0091712	A1	4/2010	Lu et al.	2011/0316645	A1	12/2011	Takeuchi et al.
2010/0100918	A1	4/2010	Egan, Jr. et al.	2012/0002973	A1	1/2012	Bruzzo et al.
2010/0111521	A1	5/2010	Kim et al.	2012/0015382	A1	1/2012	Weitz et al.
2010/0119234	A1	5/2010	Suematsu et al.	2012/0015654	A1	1/2012	Palanki et al.
2010/0121945	A1	5/2010	Gerber et al.	2012/0019420	A1	1/2012	Caimi et al.
2010/0127848	A1	5/2010	Mustapha et al.	2012/0019427	A1	1/2012	Ishikawa et al.
2010/0142435	A1	6/2010	Kim et al.	2012/0038520	A1	2/2012	Cornwell et al.
2010/0150215	A1	6/2010	Black et al.	2012/0039366	A1	2/2012	Wood et al.
2010/0153990	A1	6/2010	Ress et al.	2012/0046891	A1	2/2012	Yaney et al.
2010/0169937	A1	7/2010	Atwal et al.	2012/0054571	A1	3/2012	Howard et al.
2010/0175080	A1	7/2010	Yuen et al.	2012/0068903	A1	3/2012	Thevenard et al.
2010/0176894	A1	7/2010	Tahara et al.	2012/0077485	A1	3/2012	Shin et al.
2010/0177894	A1	7/2010	Yasuma et al.	2012/0078452	A1	3/2012	Daum et al.
2010/0185614	A1	7/2010	O'Brien et al.	2012/0084807	A1	4/2012	Thompson et al.
2010/0201313	A1	8/2010	Vorenkamp et al.	2012/0091820	A1	4/2012	Campanella et al.
2010/0214183	A1	8/2010	Stoneback et al.	2012/0092161	A1	4/2012	West et al.
2010/0214185	A1	8/2010	Sammoura et al.	2012/0093078	A1	4/2012	Perlman et al.
2010/0220024	A1	9/2010	Snow et al.	2012/0102568	A1	4/2012	Tarbotton et al.
2010/0224732	A1	9/2010	Olson et al.	2012/0105246	A1	5/2012	Sexton et al.
2010/0225426	A1*	9/2010	Unger H01P 3/06	2012/0105637	A1	5/2012	Yousefi et al.
			333/239	2012/0109545	A1	5/2012	Meynardi et al.
2010/0232539	A1	9/2010	Han et al.	2012/0109566	A1	5/2012	Adamian
2010/0243633	A1	9/2010	Huynh et al.	2012/0117584	A1	5/2012	Gordon
2010/0253450	A1	10/2010	Kim et al.	2012/0129566	A1	5/2012	Lee et al.
2010/0256955	A1	10/2010	Pupalaikis et al.	2012/0133373	A1	5/2012	Ali et al.
2010/0265877	A1	10/2010	Foxworthy et al.	2012/0137332	A1	5/2012	Kumar
2010/0266063	A1	10/2010	Harel et al.	2012/0144420	A1	6/2012	Del Sordo et al.
2010/0283693	A1	11/2010	Xie et al.	2012/0146861	A1	6/2012	Armbrecht et al.
2010/0284446	A1	11/2010	Mu et al.	2012/0153087	A1	6/2012	Collette et al.
2010/0319068	A1	12/2010	Abbadessa et al.	2012/0154239	A1	6/2012	Bar-Sade et al.
2010/0327880	A1	12/2010	Stein et al.	2012/0161543	A1	6/2012	Reuven et al.
2011/0018704	A1	1/2011	Burrows et al.	2012/0176906	A1	7/2012	Hartenstein et al.
2011/0040861	A1	2/2011	Van der Merwe et al.	2012/0181258	A1	7/2012	Shan et al.
2011/0042120	A1	2/2011	Otsuka et al.	2012/0181258	A1	7/2012	Anderson
2011/0043051	A1	2/2011	Meskens et al.	2012/0190386	A1	7/2012	Anderson
2011/0053498	A1	3/2011	Nogueira-Nine	2012/0197558	A1	8/2012	Henig et al.
2011/0068893	A1	3/2011	Lahiri et al.	2012/0201145	A1	8/2012	Ree et al.
2011/0068988	A1	3/2011	Monte et al.	2012/0214538	A1	8/2012	Kim et al.
2011/0080301	A1	4/2011	Chang et al.	2012/0224807	A1	9/2012	Winzer et al.
2011/0083399	A1	4/2011	Lettkeman et al.	2012/0226394	A1	9/2012	Marcus et al.
2011/0103274	A1	5/2011	Vavik et al.	2012/0235864	A1	9/2012	Lu et al.
2011/0107364	A1	5/2011	Lajoie et al.	2012/0235881	A1	9/2012	Pan et al.
2011/0109936	A1	5/2011	Coffee et al.	2012/0250534	A1	10/2012	Langer et al.
2011/0110404	A1	5/2011	Washiro	2012/0250752	A1	10/2012	McHann et al.
2011/0118888	A1	5/2011	White et al.	2012/0263152	A1	10/2012	Fischer et al.
2011/0132658	A1	6/2011	Miller, II et al.	2012/0267863	A1	10/2012	Kiest et al.
2011/0133865	A1	6/2011	Miller, II et al.	2012/0268340	A1	10/2012	Capozzoli et al.
2011/0133867	A1	6/2011	Miller, II et al.	2012/0270507	A1	10/2012	Qin et al.
2011/0136432	A1*	6/2011	Miller, II H01P 3/10	2012/0272741	A1	11/2012	Xiao et al.
			455/41.2	2012/0274528	A1	11/2012	McMahon et al.
2011/0140911	A1	6/2011	Pant et al.	2012/0287922	A1	11/2012	Heck et al.
2011/0141555	A1	6/2011	Fermann et al.	2012/0299671	A1	11/2012	Ikeda et al.
				2012/0304294	A1	11/2012	Fujiwara et al.
				2012/0306587	A1	12/2012	Strid et al.
				2012/0306708	A1	12/2012	Henderson et al.
				2012/0313895	A1	12/2012	Haroun et al.
				2012/0319903	A1	12/2012	Huseth et al.

(56)

References Cited

U.S. PATENT DOCUMENTS

2012/0322380	A1	12/2012	Nannarone et al.
2012/0322492	A1	12/2012	Koo et al.
2012/0324018	A1	12/2012	Metcalf et al.
2012/0327908	A1	12/2012	Gupta et al.
2012/0329523	A1	12/2012	Stewart et al.
2012/0330756	A1	12/2012	Morris et al.
2013/0002409	A1	1/2013	Molina et al.
2013/0003876	A1	1/2013	Bennett
2013/0010679	A1	1/2013	Ma et al.
2013/0015922	A1	1/2013	Liu et al.
2013/0016022	A1	1/2013	Heiks et al.
2013/0023302	A1	1/2013	Sivanesan et al.
2013/0039624	A1	2/2013	Scherer et al.
2013/0064178	A1	3/2013	Cs et al.
2013/0064311	A1	3/2013	Turner et al.
2013/0070621	A1	3/2013	Marzetta et al.
2013/0077612	A1	3/2013	Khorami et al.
2013/0077664	A1	3/2013	Lee et al.
2013/0080290	A1	3/2013	Kamm
2013/0086639	A1	4/2013	Sondhi et al.
2013/0093638	A1	4/2013	Shoemaker et al.
2013/0095875	A1	4/2013	Reuven et al.
2013/0108206	A1	5/2013	Sasaoka et al.
2013/0109317	A1	5/2013	Kikuchi et al.
2013/0117852	A1	5/2013	Stute et al.
2013/0122828	A1	5/2013	Choi et al.
2013/0124365	A1	5/2013	Pradeep
2013/0127678	A1	5/2013	Chandler et al.
2013/0136410	A1	5/2013	Sasaoka et al.
2013/0144750	A1	6/2013	Brown
2013/0148194	A1	6/2013	Altug et al.
2013/0159153	A1	6/2013	Lau et al.
2013/0159856	A1	6/2013	Ferren
2013/0160122	A1	6/2013	Choi et al.
2013/0162490	A1	6/2013	Blech et al.
2013/0166690	A1	6/2013	Shatzkamer et al.
2013/0169499	A1	7/2013	Lin et al.
2013/0173807	A1	7/2013	De Groot et al.
2013/0178998	A1	7/2013	Gadiraju et al.
2013/0182804	A1	7/2013	Yutaka et al.
2013/0185552	A1	7/2013	Steer et al.
2013/0187636	A1	7/2013	Kast et al.
2013/0191052	A1	7/2013	Fernandez et al.
2013/0201006	A1	8/2013	Kummetz et al.
2013/0201904	A1	8/2013	Toskala et al.
2013/0205370	A1	8/2013	Kalgi et al.
2013/0207681	A1	8/2013	Slupsky et al.
2013/0207859	A1	8/2013	Legay et al.
2013/0219308	A1	8/2013	Britton et al.
2013/0234904	A1	9/2013	Blech et al.
2013/0234961	A1	9/2013	Garfinkel et al.
2013/0235845	A1	9/2013	Kovvali et al.
2013/0235871	A1	9/2013	Brzozowski et al.
2013/0262656	A1	10/2013	Cao et al.
2013/0262857	A1	10/2013	Neuman et al.
2013/0263263	A1	10/2013	Narkolayev et al.
2013/0265732	A1	10/2013	Herbsommer et al.
2013/0268414	A1	10/2013	Lehtiniemi et al.
2013/0271349	A1	10/2013	Wright et al.
2013/0278464	A1	10/2013	Xia et al.
2013/0279523	A1	10/2013	Denney et al.
2013/0279561	A1	10/2013	Jin et al.
2013/0279868	A1	10/2013	Zhang et al.
2013/0285864	A1	10/2013	Clymer et al.
2013/0303089	A1	11/2013	Wang et al.
2013/0305369	A1	11/2013	Karta et al.
2013/0306351	A1	11/2013	Lambert et al.
2013/0307645	A1	11/2013	Mita et al.
2013/0311661	A1	11/2013	McPhee
2013/0314182	A1	11/2013	Takeda et al.
2013/0321225	A1	12/2013	Pettus et al.
2013/0326063	A1	12/2013	Burch et al.
2013/0326494	A1	12/2013	Nunez et al.
2013/0330050	A1	12/2013	Yang et al.
2013/0335165	A1	12/2013	Arnold et al.
2013/0336418	A1	12/2013	Tomeba et al.
2013/0341094	A1	12/2013	Taherian et al.
2013/0342287	A1	12/2013	Randall et al.
2013/0343213	A1	12/2013	Reynolds et al.
2013/0343351	A1	12/2013	Sambhwani et al.
2014/0003394	A1	1/2014	Rubin et al.
2014/0003775	A1	1/2014	Ko et al.
2014/0007076	A1	1/2014	Kim et al.
2014/0009270	A1	1/2014	Yamazaki et al.
2014/0009822	A1	1/2014	Dong et al.
2014/0015705	A1	1/2014	Ebihara et al.
2014/0019576	A1	1/2014	Lobo et al.
2014/0026170	A1	1/2014	Francisco et al.
2014/0028184	A1	1/2014	Voronin et al.
2014/0028190	A1	1/2014	Voronin et al.
2014/0028532	A1	1/2014	Ehrenberg et al.
2014/0032005	A1	1/2014	Iwamura
2014/0036694	A1	2/2014	Courtice et al.
2014/0041925	A1	2/2014	Siripurapu et al.
2014/0043189	A1	2/2014	Lee et al.
2014/0043977	A1	2/2014	Wiley et al.
2014/0044139	A1	2/2014	Dong et al.
2014/0052810	A1	2/2014	Osorio et al.
2014/0057576	A1	2/2014	Liu et al.
2014/0071818	A1	3/2014	Wang et al.
2014/0072299	A1	3/2014	Stapleton et al.
2014/0077995	A1	3/2014	Artemenko et al.
2014/0086080	A1	3/2014	Hui et al.
2014/0086152	A1	3/2014	Bontu et al.
2014/0112184	A1	4/2014	Chai
2014/0124236	A1	5/2014	Vu et al.
2014/0126914	A1	5/2014	Berlin et al.
2014/0130111	A1	5/2014	Nulty et al.
2014/0132728	A1	5/2014	Verano et al.
2014/0139375	A1	5/2014	Faragher et al.
2014/0143055	A1	5/2014	Johnson
2014/0146902	A1	5/2014	Liu et al.
2014/0148107	A1	5/2014	Maltsev et al.
2014/0155054	A1	6/2014	Henry et al.
2014/0165145	A1	6/2014	Baentsch et al.
2014/0169186	A1	6/2014	Zhu et al.
2014/0177692	A1	6/2014	Yu et al.
2014/0179302	A1	6/2014	Polehn et al.
2014/0189677	A1	7/2014	Curzi et al.
2014/0189732	A1	7/2014	Shkedi et al.
2014/0191913	A1	7/2014	Ge et al.
2014/0204000	A1	7/2014	Sato et al.
2014/0204754	A1	7/2014	Jeong et al.
2014/0207844	A1	7/2014	Mayo et al.
2014/0208272	A1	7/2014	Vats et al.
2014/0222997	A1	8/2014	Mermoud et al.
2014/0223527	A1	8/2014	Bortz et al.
2014/0225129	A1	8/2014	Inoue et al.
2014/0227905	A1	8/2014	Knott et al.
2014/0227966	A1	8/2014	Artemenko et al.
2014/0233900	A1	8/2014	Hugonnot et al.
2014/0241718	A1	8/2014	Jiang et al.
2014/0254516	A1	9/2014	Lee et al.
2014/0254896	A1	9/2014	Zhou et al.
2014/0254979	A1	9/2014	Zhang et al.
2014/0266946	A1	9/2014	Stevenson et al.
2014/0266953	A1	9/2014	Yen et al.
2014/0269260	A1	9/2014	Xue et al.
2014/0269691	A1	9/2014	Xue et al.
2014/0269972	A1	9/2014	Rada et al.
2014/0273873	A1	9/2014	Huynh et al.
2014/0285277	A1	9/2014	Herbsommer et al.
2014/0285293	A1	9/2014	Schuppener et al.
2014/0285373	A1	9/2014	Kuwahara et al.
2014/0285389	A1	9/2014	Fakharzadeh et al.
2014/0286189	A1	9/2014	Kang et al.
2014/0286235	A1	9/2014	Chang et al.
2014/0287702	A1	9/2014	Schuppener et al.
2014/0299349	A1	10/2014	Yamaguchi et al.
2014/0304498	A1	10/2014	Gonuguntla et al.
2014/0317229	A1	10/2014	Hughes et al.
2014/0320364	A1	10/2014	Gu et al.
2014/0321273	A1	10/2014	Morrill et al.
2014/0334773	A1	11/2014	Mathai et al.

(56)

References Cited

U.S. PATENT DOCUMENTS

2014/0334789	A1	11/2014	Matsuo et al.
2014/0340271	A1	11/2014	Petkov et al.
2014/0343883	A1	11/2014	Libby et al.
2014/0349696	A1	11/2014	Hyde et al.
2014/0351571	A1	11/2014	Jacobs
2014/0355525	A1	12/2014	Barzegar et al.
2014/0355989	A1	12/2014	Finckelstein
2014/0357269	A1	12/2014	Zhou et al.
2014/0359275	A1	12/2014	Murugesan et al.
2014/0362374	A1	12/2014	Santori
2014/0362694	A1	12/2014	Rodrigues
2014/0368301	A1	12/2014	Herbsommer et al.
2014/0369430	A1	12/2014	Parnell
2014/0372068	A1	12/2014	Seto et al.
2014/0373053	A1	12/2014	Leley et al.
2014/0376655	A1	12/2014	Ruan et al.
2015/0008996	A1	1/2015	Jessup et al.
2015/0009089	A1	1/2015	Pesa
2015/0016260	A1	1/2015	Chow et al.
2015/0017473	A1	1/2015	Verhoeven et al.
2015/0022399	A1	1/2015	Clymer et al.
2015/0026460	A1	1/2015	Walton
2015/0029065	A1	1/2015	Cheng
2015/0036610	A1	2/2015	Kim et al.
2015/0042526	A1	2/2015	Zeine
2015/0048238	A1	2/2015	Kawai
2015/0049998	A1	2/2015	Dumais
2015/0061859	A1	3/2015	Matsuoka et al.
2015/0065166	A1	3/2015	Ward et al.
2015/0070231	A1	3/2015	Park et al.
2015/0071594	A1	3/2015	Register
2015/0073594	A1	3/2015	Trujillo et al.
2015/0077740	A1	3/2015	Fuse
2015/0078756	A1	3/2015	Soto
2015/0084660	A1	3/2015	Knierim et al.
2015/0084703	A1	3/2015	Sanduleanu
2015/0084814	A1	3/2015	Rojanski et al.
2015/0091650	A1	4/2015	Nobbe
2015/0094104	A1	4/2015	Wilmhoff et al.
2015/0098387	A1	4/2015	Garg et al.
2015/0099555	A1	4/2015	Krishnaswamy et al.
2015/0102972	A1	4/2015	Scire-Scappuzzo et al.
2015/0103685	A1	4/2015	Butchko et al.
2015/0104005	A1	4/2015	Holman
2015/0109178	A1	4/2015	Hyde et al.
2015/0116154	A1	4/2015	Artemenko
2015/0185425	A1	4/2015	Gundel et al.
2015/0122886	A1	5/2015	Koch
2015/0126107	A1	5/2015	Bennett et al.
2015/0130675	A1	5/2015	Parsche
2015/0138022	A1	5/2015	Takahashi
2015/0138144	A1	5/2015	Tanabe
2015/0153248	A1	6/2015	Hayward et al.
2015/0156266	A1	6/2015	Gupta
2015/0162988	A1	6/2015	Henry et al.
2015/0171522	A1	6/2015	Liu et al.
2015/0172036	A1	6/2015	Katar et al.
2015/0181449	A1	6/2015	Didenko et al.
2015/0195349	A1	7/2015	Cardamore
2015/0195719	A1	7/2015	Rahman
2015/0201228	A1	7/2015	Hasek
2015/0207527	A1	7/2015	Eliasz et al.
2015/0214615	A1	7/2015	Patel et al.
2015/0215268	A1	7/2015	Dinha
2015/0223078	A1	8/2015	Bennett et al.
2015/0223113	A1	8/2015	Matsunaga
2015/0223160	A1	8/2015	Ho
2015/0230109	A1	8/2015	Turner et al.
2015/0236778	A1	8/2015	Jalali
2015/0236779	A1	8/2015	Jalali
2015/0237519	A1	8/2015	Ghai
2015/0249965	A1	9/2015	Dussmann et al.
2015/0263424	A1	9/2015	Sanford
2015/0271830	A1	9/2015	Shin et al.
2015/0276577	A1	10/2015	Ruege et al.
2015/0277569	A1	10/2015	Sprenger
2015/0280328	A1	10/2015	Sanford et al.
2015/0284079	A1	10/2015	Matsuda
2015/0288532	A1	10/2015	Veysseh et al.
2015/0289247	A1	10/2015	Liu et al.
2015/0303892	A1	10/2015	Desclos
2015/0304045	A1	10/2015	Henry et al.
2015/0304869	A1	10/2015	Johnson et al.
2015/0311951	A1	10/2015	Hariz
2015/0312774	A1	10/2015	Lau
2015/0318610	A1	11/2015	Lee et al.
2015/0323948	A1	11/2015	Jeong
2015/0325913	A1	11/2015	Vagman
2015/0326274	A1	11/2015	Flood
2015/0333386	A1	11/2015	Kaneda et al.
2015/0333804	A1	11/2015	Yang et al.
2015/0334769	A1	11/2015	Kim et al.
2015/0339912	A1	11/2015	Farrand et al.
2015/0344136	A1	12/2015	Dahlstrom
2015/0349415	A1	12/2015	Iwanaka
2015/0356482	A1	12/2015	Whipple et al.
2015/0356848	A1	12/2015	Hatch
2015/0369660	A1	12/2015	Yu
2015/0370251	A1	12/2015	Siegel et al.
2015/0373557	A1	12/2015	Bennett et al.
2015/0380814	A1	12/2015	Boutayeb et al.
2015/0382208	A1	12/2015	Elliott et al.
2016/0006129	A1	1/2016	Haziza
2016/0012460	A1	1/2016	Kruglick
2016/0014749	A1	1/2016	Kang et al.
2016/0021545	A1	1/2016	Shaw
2016/0026301	A1	1/2016	Zhou et al.
2016/0029009	A1	1/2016	Lu et al.
2016/0038074	A1	2/2016	Brown et al.
2016/0043478	A1	2/2016	Hartenstein
2016/0044705	A1	2/2016	Gao
2016/0050028	A1	2/2016	Henry et al.
2016/0056543	A1	2/2016	Kwiatkowski
2016/0063642	A1	3/2016	Luciani et al.
2016/0064794	A1	3/2016	Henry et al.
2016/0065252	A1	3/2016	Preschutti
2016/0065335	A1	3/2016	Koo et al.
2016/0066191	A1	3/2016	Li
2016/0068265	A1	3/2016	Hoareau et al.
2016/0068277	A1	3/2016	Manitta
2016/0069934	A1	3/2016	Saxby et al.
2016/0070265	A1	3/2016	Liu et al.
2016/0072173	A1	3/2016	Herbsommer et al.
2016/0072191	A1	3/2016	Iwai
2016/0072287	A1	3/2016	Jia
2016/0079769	A1	3/2016	Corum et al.
2016/0079771	A1	3/2016	Corum
2016/0079809	A1	3/2016	Corum et al.
2016/0080035	A1	3/2016	Fuchs et al.
2016/0080839	A1	3/2016	Fuchs et al.
2016/0082460	A1	3/2016	McMaster et al.
2016/0087344	A1	3/2016	Artemenko et al.
2016/0088498	A1	3/2016	Sharawi
2016/0094420	A1	3/2016	Clemm et al.
2016/0094879	A1	3/2016	Gerszberg et al.
2016/0069935	A1	4/2016	Kreikebaum et al.
2016/0099749	A1	4/2016	Bennett et al.
2016/0100324	A1	4/2016	Henry et al.
2016/0103199	A1	4/2016	Rappaport
2016/0105218	A1	4/2016	Henry et al.
2016/0105233	A1	4/2016	Jalali
2016/0105239	A1	4/2016	Henry et al.
2016/0105255	A1	4/2016	Henry et al.
2016/0111890	A1	4/2016	Corum et al.
2016/0112092	A1	4/2016	Henry et al.
2016/0112093	A1	4/2016	Barzegar
2016/0112094	A1	4/2016	Stuckman et al.
2016/0112115	A1	4/2016	Henry et al.
2016/0112132	A1	4/2016	Henry et al.
2016/0112133	A1	4/2016	Henry et al.
2016/0112135	A1	4/2016	Henry et al.
2016/0112263	A1	4/2016	Henry et al.
2016/0116914	A1	4/2016	Mucci
2016/0118717	A1	4/2016	Britz et al.

(56)

References Cited

U.S. PATENT DOCUMENTS

2016/0124071 A1 5/2016 Baxley et al.
 2016/0127931 A1 5/2016 Baxley et al.
 2016/0131347 A1 5/2016 Hill et al.
 2016/0134006 A1 5/2016 Ness et al.
 2016/0135132 A1 5/2016 Donepudi et al.
 2016/0137311 A1 5/2016 Peverill et al.
 2016/0139731 A1 5/2016 Kim
 2016/0149312 A1 5/2016 Henry et al.
 2016/0149614 A1 5/2016 Barzegar
 2016/0149636 A1 5/2016 Gerszberg et al.
 2016/0149665 A1 5/2016 Henry et al.
 2016/0149731 A1 5/2016 Henry et al.
 2016/0149753 A1 5/2016 Gerszberg et al.
 2016/0150427 A1 5/2016 Ramanath
 2016/0153938 A1 6/2016 Balasubramaniam et al.
 2016/0164571 A1 6/2016 Bennett et al.
 2016/0164573 A1 6/2016 Birk et al.
 2016/0165472 A1 6/2016 Gopalakrishnan et al.
 2016/0165478 A1 6/2016 Yao et al.
 2016/0174040 A1 6/2016 Roberts et al.
 2016/0179134 A1 6/2016 Ryu
 2016/0181701 A1 6/2016 Sangaran et al.
 2016/0182161 A1 6/2016 Barzegar
 2016/0182981 A1 6/2016 Minarik et al.
 2016/0188291 A1 6/2016 Vilermo et al.
 2016/0189101 A1 6/2016 Kantor et al.
 2016/0197392 A1 7/2016 Henry et al.
 2016/0197409 A1 7/2016 Henry et al.
 2016/0197630 A1 7/2016 Kawasaki
 2016/0197642 A1 7/2016 Henry et al.
 2016/0207627 A1 7/2016 Hoareau et al.
 2016/0212065 A1 7/2016 To et al.
 2016/0212641 A1 7/2016 Kong et al.
 2016/0214717 A1 7/2016 De Silva
 2016/0218407 A1 7/2016 Henry et al.
 2016/0218437 A1 7/2016 Guntupalli
 2016/0221039 A1 8/2016 Fuchs et al.
 2016/0224235 A1 8/2016 Forsstrom
 2016/0226681 A1 8/2016 Henry et al.
 2016/0244165 A1 8/2016 Patrick et al.
 2016/0248149 A1 8/2016 Kim et al.
 2016/0248165 A1 8/2016 Henry
 2016/0248509 A1 8/2016 Henry
 2016/0249233 A1 8/2016 Murray
 2016/0252970 A1 9/2016 Dahl
 2016/0261309 A1 9/2016 Henry
 2016/0261310 A1 9/2016 Fuchs et al.
 2016/0261311 A1 9/2016 Henry et al.
 2016/0261312 A1 9/2016 Fuchs et al.
 2016/0269156 A1 9/2016 Barzegar et al.
 2016/0276725 A1 9/2016 Barnickel et al.
 2016/0277939 A1 9/2016 Olcott et al.
 2016/0278094 A1 9/2016 Henry et al.
 2016/0285508 A1 9/2016 Bennett et al.
 2016/0285512 A1 9/2016 Henry et al.
 2016/0294444 A1 10/2016 Gerszberg et al.
 2016/0294517 A1 10/2016 Barzegar et al.
 2016/0295431 A1 10/2016 Henry et al.
 2016/0315659 A1 10/2016 Henry
 2016/0315660 A1 10/2016 Henry
 2016/0315661 A1 10/2016 Henry
 2016/0315662 A1 10/2016 Henry
 2016/0322691 A1 11/2016 Bennett et al.
 2016/0336091 A1 11/2016 Henry et al.
 2016/0336092 A1 11/2016 Henry et al.
 2016/0336636 A1 11/2016 Henry et al.
 2016/0336996 A1 11/2016 Henry
 2016/0336997 A1 11/2016 Henry
 2016/0351987 A1 12/2016 Henry
 2016/0359523 A1 12/2016 Bennett
 2016/0359524 A1 12/2016 Bennett et al.
 2016/0359529 A1 12/2016 Bennett et al.
 2016/0359530 A1 12/2016 Bennett
 2016/0359541 A1 12/2016 Bennett
 2016/0359542 A1 12/2016 Bennett

2016/0359543 A1 12/2016 Bennett et al.
 2016/0359544 A1 12/2016 Bennett
 2016/0359546 A1 12/2016 Bennett
 2016/0359547 A1 12/2016 Bennett
 2016/0359649 A1 12/2016 Bennett et al.
 2016/0360511 A1 12/2016 Barzegar
 2016/0360533 A1 12/2016 Bennett et al.
 2016/0365175 A1 12/2016 Bennett et al.
 2016/0365893 A1 12/2016 Bennett et al.
 2016/0365894 A1 12/2016 Bennett et al.
 2016/0365897 A1 12/2016 Gross
 2016/0365916 A1 12/2016 Bennett et al.
 2016/0365943 A1 12/2016 Henry et al.
 2016/0365966 A1 12/2016 Bennett et al.
 2016/0366586 A1 12/2016 Gross et al.
 2016/0366587 A1 12/2016 Gross et al.
 2016/0373937 A1 12/2016 Bennett et al.
 2016/0380327 A1 12/2016 Henry
 2016/0380328 A1 12/2016 Henry
 2016/0380358 A1 12/2016 Henry
 2016/0380701 A1 12/2016 Henry et al.
 2016/0380702 A1 12/2016 Henry et al.
 2017/0018174 A1 1/2017 Gerszberg
 2017/0018332 A1 1/2017 Barzegar et al.
 2017/0018830 A1 1/2017 Henry et al.
 2017/0018831 A1 1/2017 Henry et al.
 2017/0018832 A1 1/2017 Henry et al.
 2017/0018833 A1 1/2017 Henry et al.
 2017/0018851 A1 1/2017 Hnery et al.
 2017/0018852 A1 1/2017 Adriaola et al.
 2017/0018856 A1 1/2017 Henry et al.
 2017/0019130 A1 1/2017 Hnery et al.
 2017/0019131 A1 1/2017 Henry et al.
 2017/0019150 A1 1/2017 Henry
 2017/0019189 A1 1/2017 Henry et al.

FOREIGN PATENT DOCUMENTS

AU 606303 B2 1/1991
 AU 7261000 A 4/2001
 AU 760272 B2 5/2003
 AU 2005227368 B2 2/2009
 AU 2010101079 A4 11/2010
 AU 2007215252 B2 1/2011
 AU 2014200748 A1 3/2014
 CA 1136267 A1 11/1982
 CA 1211813 A1 9/1986
 CA 1328009 C 3/1994
 CA 2260380 C 12/2000
 CA 2348614 A1 3/2001
 CA 2449596 A1 6/2005
 CA 2515560 A1 2/2007
 CA 2664573 A1 4/2008
 CA 2467988 C 11/2010
 CA 2777147 A1 4/2011
 CA 2814529 A1 4/2012
 CA 2787580 A1 2/2013
 CA 2927054 A1 5/2015
 CA 2940976 9/2015
 CN 2116969 U 9/1992
 CN 1155354 C 7/1997
 CN 1411563 A 4/2003
 CN 1126425 C 10/2003
 CN 2730033 Y 9/2005
 CN 1833397 A 9/2006
 CN 1885736 A 12/2006
 CN 201048157 Y 4/2008
 CN 201146495 Y 11/2008
 CN 201207179 Y 3/2009
 CN 100502181 C 6/2009
 CN 201282193 Y 7/2009
 CN 101834011 U 4/2010
 CN 1823275 B 5/2010
 CN 101785201 A 7/2010
 CN 1820482 B 12/2010
 CN 101075702 B 2/2011
 CN 101978613 A 2/2011
 CN 102130698 A 7/2011
 CN 102136634 A 7/2011

(56) References Cited				
	FOREIGN PATENT DOCUMENTS			
CN	201985870 U	9/2011	EP	0896380 10/1999
CN	102208716 A	10/2011	EP	676648 B1 5/2000
CN	102280704 A	12/2011	EP	1085599 A2 3/2001
CN	102280709 A	12/2011	EP	0907983 B1 6/2001
CN	202093126 U	12/2011	EP	0756786 8/2001
CN	102351415 A	2/2012	EP	1127283 A1 8/2001
CN	102396111 A	3/2012	EP	1129550 A1 9/2001
CN	202253536 U	5/2012	EP	1184930 A1 3/2002
CN	102544736 A	7/2012	EP	1195847 A2 4/2002
CN	102590893 A	7/2012	EP	1237303 A2 9/2002
CN	102694351 A	9/2012	EP	1296146 A1 3/2003
CN	202424729 U	9/2012	EP	0772061 7/2003
CN	101662076 B	11/2012	EP	1346431 A1 9/2003
CN	102780058 A	11/2012	EP	1249056 B1 1/2004
CN	102017692 B	4/2013	EP	1376755 A1 1/2004
CN	103078673 A	5/2013	EP	1401048 A1 3/2004
CN	103117118 A	5/2013	EP	1454422 A1 9/2004
CN	103163881 A	6/2013	EP	1488397 A1 12/2004
CN	203204743 U	9/2013	EP	1509970 3/2005
CN	1863244 B	10/2013	EP	1371108 B1 6/2005
CN	101958461 B	11/2013	EP	1550327 A2 7/2005
CN	103700442 A	4/2014	EP	1341255 B8 8/2005
CN	103943925 A	7/2014	EP	1577687 A1 9/2005
CN	104052742 A	9/2014	EP	1312135 B1 11/2005
CN	104064844 A	9/2014	EP	1608110 A1 12/2005
CN	203813973 U	9/2014	EP	1624685 A2 2/2006
CN	104091987 A	10/2014	EP	1624268 A2 4/2006
CN	104092028 A	10/2014	EP	1647072 A1 4/2006
CN	203931626 U	11/2014	EP	1608110 B1 10/2006
CN	203950607 U	11/2014	EP	1793508 A1 6/2007
CN	104181552 A	12/2014	EP	1842265 A1 10/2007
CN	204538183	8/2015	EP	1898532 A2 3/2008
CN	102412442 B	10/2015	EP	1930982 A1 6/2008
CN	204760545 U	11/2015	EP	1953940 A1 8/2008
CN	105262551 A	1/2016	EP	1696509 B1 10/2009
CN	205265924	1/2016	EP	2159749 A1 3/2010
CN	105359572 A	2/2016	EP	2165550 A1 3/2010
CN	105453340	3/2016	EP	1166599 B1 5/2010
CN	105594138 A	5/2016	EP	1807950 A4 1/2011
CN	104162995 B	6/2016	EP	2404347 A2 1/2012
CN	105813193 A	7/2016	EP	2472671 A1 7/2012
DE	3504546 A1	8/1986	EP	1817855 B1 1/2013
DE	3533204 A1	3/1987	EP	2568528 A2 3/2013
DE	3533211 A1	3/1987	EP	2302735 B1 9/2013
DE	3827956 A1	3/1989	EP	2472737 B1 9/2013
DE	4027367 C1	7/1991	EP	2640115 A1 9/2013
DE	4225595 C1	9/1993	EP	2016643 B1 7/2014
DE	19501448 A1	7/1996	EP	2760081 A1 7/2014
DE	19939832 A1	2/2001	EP	2804259 A1 11/2014
DE	10043761 C2	11/2002	EP	2507939 B1 12/2014
DE	102004024356 A1	9/2005	EP	2680452 B1 1/2015
DE	69732676 T2	4/2006	EP	2838155 A1 2/2015
DE	4337835 B4	5/2008	EP	2846480 A1 3/2015
DE	102007049914 A1	4/2009	EP	2849524 A1 3/2015
DE	102012004998 A1	7/2013	EP	2850695 A1 3/2015
DE	102012203816 A1	9/2013	EP	2853902 A1 4/2015
EP	0102846	3/1984	EP	2854361 A1 4/2015
EP	0110478	6/1984	EP	2870802 A1 5/2015
EP	0136818	4/1985	EP	2710400 A4 6/2015
EP	0280379	8/1988	EP	3076482 A1 10/2016
EP	0330303	8/1989	ES	2120893 A1 11/1998
EP	0331248	9/1989	FR	2119804 A1 8/1972
EP	0342149	11/1989	FR	2214161 A1 8/1974
EP	0391719	4/1990	FR	2416562 A1 8/1979
EP	425979 A2	5/1991	FR	2583226 A1 12/1986
EP	0485467	5/1992	FR	2691602 A1 11/1993
EP	272785 B1	2/1994	FR	2849728 A1 7/2004
EP	0651487	10/1994	FR	2841387 B1 4/2006
EP	0371660	4/1996	FR	2893717 A1 5/2007
EP	0756392	1/1997	FR	2946466 B1 3/2012
EP	834722 A2	4/1998	FR	2986376 B1 10/2014
EP	0840464	5/1998	FR	3034203 9/2016
EP	0871241 B1	10/1998	GB	175489 A 2/1922
EP	0890132	1/1999	GB	462804 A 3/1937
EP	755092 A3	4/1999	GB	529290 A 11/1940
			GB	603119 A 10/1945
			GB	589603 A 6/1947
			GB	640181 A 7/1950
			GB	663166 A 12/1951

(56)

References Cited

FOREIGN PATENT DOCUMENTS

GB	667290	A	2/1952	JP	116928	A	1/1999
GB	668827	A	3/1952	JP	1114749	A	1/1999
GB	682115	A	11/1952	JP	11239085	A	8/1999
GB	682817	A	11/1952	JP	11313022	A	11/1999
GB	731473	A	6/1955	JP	2000077889	A	3/2000
GB	746111	A	3/1956	JP	2000216623	A	8/2000
GB	751153	A	6/1956	JP	2000244238	A	9/2000
GB	767506	A	2/1957	JP	2001217634	A	8/2001
GB	835976	A	6/1960	JP	2002029247	A	1/2002
GB	845492	A	8/1960	JP	2002236174	A	8/2002
GB	859951	A	1/1961	JP	200328219	A	1/2003
GB	889856	A	2/1962	JP	2003008336	A	1/2003
GB	905417	A	9/1962	JP	2003057464	A	2/2003
GB	926958	A	5/1963	JP	2003511677	A	3/2003
GB	993561	A	5/1965	JP	3411428	B2	6/2003
GB	1004318	A	9/1965	JP	2003324309	A	11/2003
GB	1076772	A	7/1967	JP	3480153	B2	12/2003
GB	1141390	A	1/1969	JP	2003344883	A	12/2003
GB	1298387	A	11/1972	JP	2004521379	A	7/2004
GB	1383549	A	2/1974	JP	2004253853	A	9/2004
GB	1370669	A	10/1974	JP	2004274656	A	9/2004
GB	1422956	A	1/1976	JP	2004297107	A	10/2004
GB	1424351	A	2/1976	JP	2004304659	A	10/2004
GB	1468310	A	3/1977	JP	2005110231	A	4/2005
GB	1469840	A	4/1977	JP	2005182469	A	7/2005
GB	1527228	A	10/1978	JP	3734975	B2	1/2006
GB	2010528	A	6/1979	JP	2006153878	A	6/2006
GB	2045055	A	10/1980	JP	2006163886	A	6/2006
GB	1580627	A	12/1980	JP	2006166399	A	6/2006
GB	1584193	A	2/1981	JP	2007042009	A	2/2007
GB	2227369	A	7/1990	JP	2007072945	A	3/2007
GB	2247990	A	3/1992	JP	3938315	B2	6/2007
GB	2368468	A	5/2002	JP	2007174017	A	7/2007
GB	2362472	B	10/2003	JP	2007259001	A	10/2007
GB	2393370	A	3/2004	JP	4025674	B2	12/2007
GB	2394364	B	6/2005	JP	2008017263	A	1/2008
GB	2414862	A	12/2005	JP	2008021483	A	1/2008
GB	2411554	B	1/2006	JP	4072280	B2	4/2008
GB	705192		4/2007	JP	4142062	B2	8/2008
GB	714974		9/2007	JP	2008209965	A	9/2008
GB	718597		10/2007	JP	2008218362	A	9/2008
GB	2474037	A	4/2011	JP	2009004986	A	1/2009
GB	2476787	A	7/2011	JP	4252573	B2	4/2009
GB	2474605	B	9/2011	JP	4259760	B2	4/2009
GB	2485355	A	5/2012	JP	2009124229	A	6/2009
GB	2481715	B	1/2014	JP	2010045471	A	2/2010
GB	2507269	A	4/2014	JP	2010192992	A	9/2010
GB	2476149	B	7/2014	JP	2010541468	A	12/2010
GB	2532207	A	5/2016	JP	2011160446	A	8/2011
IN	261253	A1	6/2014	JP	2012058162	A	3/2012
IN	7352/CHENP/2015	A	7/2016	JP	2012090242	A	5/2012
IN	201647015348	A	8/2016	JP	2012175680	A	9/2012
JP	S50109642		9/1975	JP	2012205104	A	10/2012
JP	55124303	U	9/1980	JP	2012248035	A	12/2012
JP	55138902	U	10/1980	JP	2013046412	A	3/2013
JP	574601		1/1982	JP	2013110503	A	6/2013
JP	61178682	U	11/1986	JP	5230779	B2	7/2013
JP	61260702	A	11/1986	JP	2014045237	A	3/2014
JP	62110303	U	7/1987	JP	5475475	B2	4/2014
JP	62190903	U	8/1987	JP	5497348	B2	5/2014
JP	02214307	A	8/1990	JP	5618072	B2	11/2014
JP	03167906	A	7/1991	JP	2015095520	A	5/2015
JP	0653894		8/1991	JP	2015188174		10/2015
JP	04369905	A	12/1992	KR	20000074034		12/2000
JP	3001844	U	9/1994	KR	20020091917		12/2002
JP	077769		1/1995	KR	100624049	B1	9/2006
JP	7212126		11/1995	KR	200425873	Y1	9/2006
JP	0829545		2/1996	KR	100636388	B1	10/2006
JP	08167810	A	6/1996	KR	100725002	B1	6/2007
JP	08196022	A	7/1996	KR	100849702		7/2008
JP	08316918	A	11/1996	KR	100916077	B1	8/2009
JP	2595339	B2	4/1997	KR	100952976	B1	4/2010
JP	2639531	B2	8/1997	KR	100989064	B1	10/2010
JP	10206183	A	8/1998	KR	101060584	B1	8/2011
JP	10271071	A	10/1998	KR	101070364	B1	9/2011
				KR	101212354	B1	12/2012
				KR	101259715	B1	4/2013
				KR	101288770	B1	7/2013
				KR	20140104097	A	8/2014

(56)

References Cited

FOREIGN PATENT DOCUMENTS

KR	101435538	B1	9/2014	WO	2008061107	A2	5/2008
KR	101447809	B1	10/2014	WO	2008069358	A1	6/2008
KR	20150087455		7/2015	WO	2008070957	A1	6/2008
KR	101549622		9/2015	WO	2008102987	A1	8/2008
KR	200479199	Y1	12/2015	WO	2008117973	A1	10/2008
KR	101586236	B1	1/2016	WO	2008155769	A2	12/2008
KR	101606803		1/2016	WO	2009014704	A1	1/2009
KR	101607420	B1	3/2016	WO	2007098061	A3	2/2009
NL	69072		1/1945	WO	2009031794	A1	3/2009
RU	2129746	C1	4/1999	WO	2009035285	A2	3/2009
RU	2432647	C1	10/2011	WO	2009090602	A1	7/2009
TW	201537432		10/2015	WO	2009123404	A4	10/2009
WO	8301711	A1	5/1983	WO	2009131316	A2	10/2009
WO	9116770	A1	10/1991	WO	2010017549	A1	2/2010
WO	9210014		6/1992	WO	2010050892	A1	5/2010
WO	9323928		11/1993	WO	2010147806	A1	12/2010
WO	9424467	A1	10/1994	WO	2011006210	A1	1/2011
WO	9523440	A1	8/1995	WO	2011032605	A1	3/2011
WO	9529537	A1	11/1995	WO	2011085650	A1	7/2011
WO	199529537		11/1995	WO	2011137793	A1	11/2011
WO	9603801	A1	2/1996	WO	2012/007831		1/2012
WO	199619089		6/1996	WO	2012038816	A1	3/2012
WO	9639729	A1	12/1996	WO	2012050069	A1	4/2012
WO	WO 96/41157		12/1996	WO	2012064333	A1	5/2012
WO	9735387	A1	9/1997	WO	2012113219	A1	8/2012
WO	9737445	A1	10/1997	WO	2012171205	A1	12/2012
WO	9829853	A1	7/1998	WO	2012172565	A1	12/2012
WO	9859254	A1	12/1998	WO	2013013162	A2	1/2013
WO	WO 98/57207		12/1998	WO	2013013465	A1	1/2013
WO	9923848	A2	5/1999	WO	2013017822		2/2013
WO	9948230	A1	9/1999	WO	2013023226	A1	2/2013
WO	199945310		9/1999	WO	2013028197	A1	2/2013
WO	9967903	A1	12/1999	WO	2013035110	A2	3/2013
WO	0070891	A1	11/2000	WO	2013073548	A1	5/2013
WO	2000/74428	A1	12/2000	WO	2013100912	A1	7/2013
WO	2001014985	A1	3/2001	WO	2013112353	A1	8/2013
WO	0128159	A2	4/2001	WO	2013115802	A1	8/2013
WO	0131746	A1	5/2001	WO	2013121682	A1	8/2013
WO	0145206	A1	6/2001	WO	2013123445	A1	8/2013
WO	0192910	A2	12/2001	WO	2013/138627		9/2013
WO	02061467	A2	8/2002	WO	2013136213	A1	9/2013
WO	02061971	A1	8/2002	WO	2013157978	A1	10/2013
WO	03/005629		1/2003	WO	2013172502	A1	11/2013
WO	2003009083		1/2003	WO	2014/018434		1/2014
WO	03012614	A1	2/2003	WO	2014011438	A1	1/2014
WO	200326166		3/2003	WO	2014/045236		3/2014
WO	03026462	A1	4/2003	WO	2014065952	A1	5/2014
WO	03044981	A1	5/2003	WO	2014069941	A1	5/2014
WO	2003088418		10/2003	WO	2014083500	A1	6/2014
WO	03099740	A1	12/2003	WO	2014092644	A1	6/2014
WO	2004011995	A1	2/2004	WO	2014094559	A1	6/2014
WO	2004038891	A2	5/2004	WO	2014096868	A1	6/2014
WO	2004/051804		6/2004	WO	2014099340	A2	6/2014
WO	2004054159	A2	6/2004	WO	2013076499	A3	7/2014
WO	2004077746	A1	9/2004	WO	2014112994	A1	7/2014
WO	2005015686	A1	2/2005	WO	2014128253	A1	8/2014
WO	2005072469	A2	8/2005	WO	2014137546	A1	9/2014
WO	2006012610	A2	2/2006	WO	2014145862	A2	9/2014
WO	2006061865	A1	6/2006	WO	2014147002	A1	9/2014
WO	2006085804	A1	8/2006	WO	2014197926	A1	12/2014
WO	2006102419	A2	9/2006	WO	2015002658	A1	1/2015
WO	2006111809	A1	10/2006	WO	2015006636	A1	1/2015
WO	2006116396	A2	11/2006	WO	2015008442	A1	1/2015
WO	2006122041	A2	11/2006	WO	2015024006	A1	2/2015
WO	2006125279	A1	11/2006	WO	2015027033	A1	2/2015
WO	2007000777	B1	2/2007	WO	2015035463	A1	3/2015
WO	2006050331	A3	3/2007	WO	2015/055230		4/2015
WO	2007031435	A1	3/2007	WO	2015052478		4/2015
WO	2007071797	A1	6/2007	WO	2015052480		4/2015
WO	2007148097	A2	12/2007	WO	2015069090	A1	5/2015
WO	2008003939	A1	1/2008	WO	2015069431	A2	5/2015
WO	2007094944	A3	3/2008	WO	2015077644		5/2015
WO	2007149746	A3	4/2008	WO	2015088650	A1	6/2015
WO	2008044062	A1	4/2008	WO	2015120626		8/2015
WO	2008055084	A2	5/2008	WO	2015123623	A1	8/2015
				WO	2015132618	A1	9/2015
				WO	2015167566	A1	11/2015
				WO	2015175054	A2	11/2015
				WO	2015197580	A1	12/2015

(56)

References Cited

FOREIGN PATENT DOCUMENTS

WO	2016003291	A1	1/2016
WO	2016004003		1/2016
WO	2016009402	A2	1/2016
WO	2016012889		1/2016
WO	2016027007		2/2016
WO	2016028767		2/2016
WO	2016/043949		3/2016
WO	2016032592	A1	3/2016
WO	2016036951	A1	3/2016
WO	2016043949	A1	3/2016
WO	2016048214	A1	3/2016
WO	2016048257	A1	3/2016
WO	2016/064502		4/2016
WO	2016053572	A1	4/2016
WO	2016053573	A1	4/2016
WO	2016060761	A1	4/2016
WO	2016060762	A1	4/2016
WO	2016061021	A1	4/2016
WO	2016064505	A1	4/2016
WO	2016064516	A1	4/2016
WO	2016064700	A2	4/2016
WO	2016073072	A1	5/2016
WO	2016081125		5/2016
WO	2016081128		5/2016
WO	2016081129	A1	5/2016
WO	2016081134		5/2016
WO	2016081136		5/2016
WO	2015090382		6/2016
WO	2016086306	A1	6/2016
WO	2016089491		6/2016
WO	2016089492	A1	6/2016
WO	2016096029	A1	6/2016
WO	2016/125161		8/2016
WO	2016/133509		8/2016
WO	2016122409	A1	8/2016
WO	2016/137982		9/2016
WO	2016145411		9/2016
WO	2016161637	A1	10/2016
WO	2016169058	A1	10/2016
WO	2016171907		10/2016
WO	2016176030		11/2016
WO	2016200492		12/2016
WO	2016200579		12/2016
WO	2017/011099		1/2017
WO	2017011100		1/2017
WO	2017011101		1/2017
WO	2017011102		1/2017
WO	2017011103		1/2017
WO	2017011227		1/2017

OTHER PUBLICATIONS

“Brackets, Conduit Standoff”, Hubbell Power Systems, Inc., hubbellpowersystems.com, Dec. 2, 2010, 2 pages.

“Broadband Negligible Loss Metamaterials”, Computer Electromagnetics and Antennas Research Laboratory, cearl.ee.psu.edu., May 15, 2012, 3 pages.

“Broadband Over Power Lines (BPL): Developments and Policy Issues”, Organisation for Economic Co-operation and Development, Directorate for Science, Technology and Industry, Committee for Information, Computer and Communications Policy, Jun. 2, 2009, 35 pages.

“Broadband: Bringing Home the Bits: Chapter 4 Technology Options and Economic Factors”, The National Academies Press, nap.edu, 2002, 61 pages.

“Cisco Aironet 1500 Series Access Point Large Pole Mounting Kit Instructions”, www.cisco.com/c/en/us/td/docs/wireless/antenna/installation/guide/18098.html, 2008, 9 pages.

“Cisco IP VSAT Satellite WAN Network Module for Cisco Integrated Services Routers”, www.cisco.com/c/en/us/products/collateral/interfaces-modules/ip-vsatsatellite-wan-module/product_data_sheet0900aecd804bbf6f.html, Jul. 23, 2014, 6 pages.

“Cloud Management”, Cisco Meraki, cisco.com., Sep. 11, 2015 2 pages.

“Decryption: Identify & Control Encrypted Traffic”, Palo Alto Networks, paloaltonetworks.com, Mar. 7, 2011, 4 pages.

“Delivering broadband over existing wiring”, Cabling Installation & Maintenance, cablinginstall.com, May 1, 2002, 6 pages.

“Directional Couplers—Coaxial and Waveguide”, Connecticut Microwave Corporation, http://connecticutmicrowave.com, Accessed Aug. 2016 21 pages.

“Doubly-fed Cage-cone Combined Broadband Antennas for Marine Applications”, http://www.edatop.com/down/paper/antenna/%E5%A4%A9%E7%BA%BF%E8%AE%BE%E8%AE%A1-890w5nebp5ilpq.pdf, 2007, 7 pages.

“Dual Band Switched-Parasitic Wire Antennas for Communications and Direction Finding”, www.researchgate.net/profile/David_Thiel2/publication/3898574_Dual_band_switched-parasitic_wire_antennas_for_communications_and_direction_finding/links/0fcfd5091b4273ce54000000.pdf, 2000, 5 pages.

“Electronic Countermeasure (ECM) Antennas”, vol. 8, No. 2, Apr. 2000, 2 pages.

“Elliptical Polarization”, Wikipedia, http://en.wikipedia.org/wiki/Elliptical_polarization, Apr. 21, 2015 3 pages.

“Harvest energy from powerline”, www.physicsforums.com/threads/harvest-energy-from-powerline.685148/, Discussion thread about harvesting power from powerlines that includes the suggestion of clamping a device to the power line., 2013, 8 pages.

“Identity Management”, Tuomas Aura CSE-C3400 Information Security, Aalto University, Autumn 2014, 33 pgs.

“IEEE Standard for Information technology—Local and metropolitan area networks—Specific requirements”, Part 15.4: Wireless Medium Access Control (MAC) and Physical Layer (PHY) Specifications for Low Rate Wireless Personal Area Networks (WPANs), in IEEE Std 802.15.4, (Revision of IEEE Std 802.15.4-2003), Sep. 7, 2006, 1-320.

“International Preliminary Report on Patentability”, PCT/US2014/039746, dated Dec. 10, 2015.

“International Preliminary Report on Patentability”, PCT/US2014/060841, dated May 19, 2016 8 pages.

“International Preliminary Report on Patentability & Written Opinion”, PCT/US2014/061445, dated Jun. 23, 2016 9 pages.

“International Search Report & Written Opinion”, PCT/US2015/034827, dated Sep. 30, 2015.

“International Search Report & Written Opinion”, PCT/US2015/056316, dated Jan. 21, 2016.

“International Search Report & Written Opinion”, PCT/US2015/056320, dated Jan. 29, 2016.

“International Search Report & Written Opinion”, PCT/US2015/056365, dated Jan. 22, 2016.

“International Search Report & Written Opinion”, PCT/US2015/056368, dated Jan. 25, 2016.

“International Search Report & Written Opinion”, PCT/US2015/056598, dated Jan. 28, 2016.

“International Search Report & Written Opinion”, PCT/US2015/056615, dated Jan. 21, 2016.

“International Search Report & Written Opinion”, PCT/US2015/056626, dated Jan. 21, 2016.

“International Search Report & Written Opinion”, PCT/US2015/056632, dated Jan. 26, 2016.

“International Search Report & Written Opinion”, PCT/US2016/013988, dated Apr. 8, 2016.

“International Search Report & Written Opinion”, PCT/US2016/035384, dated Oct. 31, 2016.

“International Search Report & Written Opinion”, PCT/US2016/020001, dated May 23, 2016.

“International Search Report & Written Opinion”, PCT/US2016/026193, dated Jun. 1, 2016.

“International Search Report & Written Opinion”, PCT/US2016/026860, dated Jun. 1, 2016.

“International Search Report & Written Opinion”, PCT/US2016/026318, dated Jun. 15, 2016.

“International Search Report & Written Opinion”, PCT/US16/027397, dated Jun. 24, 2016.

(56)

References Cited

OTHER PUBLICATIONS

- “International Search Report & Written Opinion”, PCT/US2016/028412, dated Jun. 27, 2016.
- “International Search Report & Written Opinion”, PCT/US2016/028206, dated Jun. 29, 2016.
- “International Search Report & Written Opinion”, PCT/US16/033182, dated Jul. 12, 2016.
- “International Search Report & Written Opinion”, PCT/US2016/036290, dated Aug. 11, 2016.
- “International Search Report & Written Opinion”, PCT/US2016/036551, dated Aug. 11, 2016.
- “International Search Report & Written Opinion”, PCT/US2016/036798, dated Aug. 11, 2016.
- “International Search Report & Written Opinion”, PCT/US2016/028205, dated Aug. 16, 2016.
- “International Search Report & Written Opinion”, PCT/US2016/032460, dated Aug. 17, 2016.
- “International Search Report & Written Opinion”, PCT/US2016/036303, dated Aug. 24, 2016.
- “International Search Report & Written Opinion”, PCT/US2016/036288, dated Sep. 1, 2016.
- “International Search Report & Written Opinion”, PCT/2016/035383, dated Sep. 2, 2016.
- “International Search Report & Written Opinion”, PCT/US16/036284, dated Sep. 8, 2016.
- “International Search Report & Written Opinion”, PCT/US2016/036286, dated Sep. 13, 2016.
- “International Search Report & Written Opinion”, PCT/US2016/036293, dated Sep. 15, 2016.
- “International Search Report & Written Opinion”, PCT/US2014/039746, dated Jan. 12, 2015.
- “International Search Report & Written Opinion”, PCT/US2014/060841, dated Jan. 7, 2015.
- “International Search Report & Written Opinion”, PCT/US2016/040992, dated Oct. 17, 2006.
- “International Search Report & Written Opinion”, PCT/US2015/039848, dated Oct. 20, 2015.
- “International Search Report & Written Opinion”, PCT/US2015/047315, dated Oct. 30, 2015.
- “International Search Report & Written Opinion”, PCT/US2015/048454, dated Nov. 11, 2015.
- “International Search Report & Written Opinion”, PCT/US16/050488, dated Nov. 11, 2016.
- “International Search Report & Written Opinion”, PCT/US16/050345, dated Nov. 15, 2016.
- “International Search Report & Written Opinion”, PCT/US2015/049928, dated Nov. 16, 2015.
- “International Search Report & Written Opinion”, PCT/US2015/049932, dated Nov. 16, 2015.
- “International Search Report & Written Opinion”, PCT/US2016/050346, dated Nov. 17, 2016.
- “International Search Report & Written Opinion”, PCT/US2015/049927, dated Nov. 24, 2015.
- “International Search Report & Written Opinion”, PCT/US2015/051193, dated Nov. 27, 2015.
- “International Search Report & Written Opinion”, PCT/US2015/051146, dated Dec. 15, 2015.
- “International Search Report & Written Opinion”, PCT/US2015/051183, dated Dec. 15, 2015.
- “International Search Report & Written Opinion”, PCT/US2015/051194, dated Dec. 15, 2015.
- “International Search Report & Written Opinion”, PCT/US2015/051578, dated Dec. 17, 2015.
- “International Search Report & Written Opinion”, PCT/US2015/051583, dated Dec. 21, 2015.
- “International Search Report & Written Opinion”, PCT/US2015/048458, dated Dec. 23, 2015.
- “International Search Report & Written Opinion”, PCT/US2015/051213, dated Dec. 4, 2015.
- “International Search Report & Written Opinion”, PCT/US2015/051163, dated Dec. 7, 2015.
- “International Search Report & Written Opinion”, PCT/US2014/061445, dated Feb. 10, 2015.
- “International Search Report & Written Opinion”, PCT/US16/28207, dated Jun. 15, 2016.
- “International Search Report & Written Opinion”, PCT/US16/027403, dated Jun. 22, 2016.
- “International Search Report & Written Opinion”, PCT/US2016/015501, dated Apr. 29, 2016 11 pages.
- “International Search Report & Written Opinion”, PCT/US2016/050860, dated Nov. 17, 2016 11 pages.
- “International Search Report & Written Opinion”, PCT/US2016/050344, dated Nov. 25, 2016 16 pages.
- “International Search Report & Written Opinion”, PCT/US2015/047225, dated Nov. 6, 2015 dated Nov. 6, 2015.
- “International Search Report and Written Opinion”, PCT/US16/027398, dated Jun. 24, 2016.
- “International Search Report and Written Opinion”, PCT/US16/028395, dated Jun. 29, 2016.
- “International Search Report and Written Opinion”, PCT/US2016/028417, Authorized officer Brigitte Bettiol, dated Jul. 5, 2016.
- “International Search Report and Written Opinion”, PCT/US16/032441, dated Jul. 29, 2016.
- “International Search Report and Written Opinion”, PCT/US2016/036285, dated Aug. 23, 2016.
- “International Search Report and Written Opinion”, PCT/US16/036388, dated Aug. 30, 2016.
- “International Search Report and Written Opinion”, PCT/US2016/036297, dated Sep. 5, 2016.
- “International Search Report and Written Opinion”, PCT/US2016/036292, dated Sep. 13, 2016.
- “International Search Report and Written Opinion”, PCT/US2016/046315, dated Nov. 3, 2016.
- “International Search Report and Written Opinion”, PCT/US2016/050039, dated Nov. 14, 2016.
- “International Search Report and Written Opinion”, PCT/US2016/050347, dated Nov. 15, 2016.
- “International Search Report and Written Opinion”, PCT/US2016/051217, dated Nov. 29, 2016.
- “International Search Report and Written Opinion”, PCT/US2016/028197, dated Jun. 24, 2016.
- “International Search Report and Written Opinion”, PCT/US2016/036289, dated Aug. 11, 2016.
- “International Search Report and Written Opinion”, PCT/US2016/036295, dated Aug. 30, 2016.
- “International Search Report and Written Opinion”, PCT/US2016/030964, dated Aug. 4, 2016.
- “International Search Report and Written Opinion”, PCT/US2016/036553, dated Aug. 30, 2016, 1-14.
- “International Search Report and Written opinion”, PCT/US2016/036556, dated Sep. 22, 2016.
- “International Searching Authority”, International Search Report and Written Opinion, dated Sep. 28, 2016 1-12.
- “Invitation to Pay Additional Fees & Partial Search Report”, PCT/US2016/028205, dated Jun. 22, 2016.
- “Invitation to Pay Additional Fees & Partial Search Report”, PCT/US2016/032430, dated Jun. 22, 2016.
- “Invitation to Pay Additional Fees and, Where Applicable, Protest Fee”, PCT/US2016/035384, dated Aug. 31, 2016 7 pages.
- “Iptek All-Optical Sensors”, www.ipitek.com/solutions-by-industry/all-optical-sensors, Jun. 2, 2014, 3 pages.
- “Micromem Demonstrates UAV Installation of Power Line Monitoring Mounting System”, MicroMem, micromem.com, Mar. 4, 2015 1-3.
- “Newsletter 4.4—Antenna Magus version 4.4 released!”, antennamagus.com, Aug. 10, 2013, 8 pages.
- “PCT International Search Report”, dated Oct. 24, 2016 1-13.
- “PCT International Search Report and Written Opinion”, dated Oct. 10, 2016 1-15.
- “Quickly identify malicious traffics: Detect”, lancop.com, Mar. 15, 2015 8 pages.

(56) **References Cited**

OTHER PUBLICATIONS

- “Radar at St Andrews”, mmwaves.epr.st-andrews.ac.uk, Feb. 4, 2011, 2 pages.
- “Resilience to Smart Meter Disconnect Attacks”, ADSC Illinois at Singapore PTE LTD., <http://publish.illinois.edu/integrativesecurityassessment/resiliencetosmartmeterdisconnectattacks>, 2015 2 pages.
- “RF Sensor Node Development Platform for 6LoWPAN and 2.4 GHz Applications”, www.ti.com/tool/TIDM-RE-SENSORNODE, 06/02/014, 3 pages.
- Technology Brief 13: Touchscreens and Active Digitizers, <https://web.archive.org/web/20100701004625/http://web.engr.oregonstate.edu/~moon/engr203/read/read4.pdf>, 2010, 289-311.
- “The world’s first achievement of microwave electric-field measurement utilizing an optical electric-field sensor mounted on an optical fiber, within a microwave discharge ion engine boarded on asteroid explorers etc.”, Investigation of internal phenomena and performance improvement in microwave discharge ion engines, Japan Aerospace Exploration Agency (JAXA), Nippon Telegraph and Telephone Corporation, Aug. 7, 2013, 4 pages.
- “Transducer”, IEEE Std 100-2000, Sep. 21, 2015 1154.
- “Wireless powerline sensor”, [wikipedia.org](http://en.wikipedia.org/wiki/Wireless_powerline_sensor), http://en.wikipedia.org/wiki/Wireless_powerline_sensor, 2014, 3 pages.
- Ace, “Installing Satellite Accessories”, www.acehardware.com, May 8, 2006, 4 pages.
- Adabo, Geraldo J., “Long Range Unmanned Aircraft System for Power Line Inspection of Brazilian Electrical System”, *Journal of Energy and Power Engineering* 8 (2014), Feb. 28, 2014, 394-398.
- Aerohive Networks, “HiveManager Network Management System”, www.aerohive.com, Sep. 2015 3 pages.
- Akiba, Shigeyuki et al., “Photonic Architecture for Beam Forming of RF Phased Array Antenna”, *Optical Fiber Communication Conference*, Optical Society of America, Abstract Only, 2014, 1 page.
- Al-Ali, A.R. et al., “Mobile RFID Tracking System”, *Information and Communication Technologies: From Theory to Applications, ICTTA 2008, 3rd International Conference on IEEE*, 2008, 394 pages.
- Alam, M. N. et al., “Novel Surface Wave Exciters for Power Line Fault Detection and Communications”, Department of Electrical Engineering, University of South Carolina, *Antennas and Propagation (APSURS)*, 2011 IEEE International Symposium, IEEE, 2011, 1-4.
- Alam, MD N. et al., “Design and Application of Surface Wave Sensors for nonintrusive Power Line Fault Detection”, *IEEE Sensors Journal*, IEEE Service Center, New York, NY, US, vol. 13, No. 1, Jan. 1, 2013, 339-347.
- Alaridhee, T. et al., “Transmission properties of slanted annular aperture arrays. Giant energy deviation over sub-wavelength distance”, *Optics express* 23.9, 2015 11687-11701.
- Ali, Muhammad Q. et al., “Randomizing AMI configuration for proactive defense in smart grid”, *Smart Grid Communications (SmartGridComm)*, IEEE International Conference on. IEEE, Abstract Only, 2013, 2 pages.
- Ali, Tariq et al., “Diagonal and Vertical Routing Protocol for Underwater Wireless Sensor Network”, *Procedia—Social and Behavioral Sciences* 129, 2014, 372-379.
- Allen, Jeffrey et al., “New Concepts in Electromagnetic Materials and Antennas”, Air Force Research Laboratory, Jan. 2015 80 pages.
- Amirshahi, P. et al., “Transmission channel model and capacity of overhead multiconductor mediumvoltage powerlines for broadband communications”, *Consumer Communications and Networking Conference*, 2005, 5 pages.
- Amt, John H. et al., “Flight Testing of a Pseudolite Navigation System on a UAV”, Air Force Institute of Technology: ION Conference, Jan. 2007, 9 pages.
- Angove, Alex, “How the NBN Differs from ADSL2+, Cable and Wireless”, www.whistleout.com.au/Broadband/Guides/How-the-NBN-Differs-from-ADSL2-Cable-and-Wireless, Jul. 30, 2014, 4 pages.
- Antenna Magus, “Waveguide-fed Conical Horn”, www.antennamagus.com, Aug. 2015 1 page.
- Antennamagus, “Parabolic focus pattern fed reflector with shroud”, antennamagus.com, Jul. 4, 2014, 2 pages.
- Arage, Alebel et al., “Measurement of wet antenna effects on millimetre wave propagation”, 2006 IEEE Conference on Radar, Abstract Only, 2006, 1 page.
- Ares-Pena, Francisco J. et al., “A simple alternative for beam reconfiguration of array antennas”, *Progress in Electromagnetics Research* 88, 2008, 227-240.
- Arthur, Joseph Kweku et al., “Improving QoS in UMTS Network in ACCRA Business District Using Tower-Less Towers”, *IPASJ International Journal of Electrical Engineering (IJEE)*, vol. 2, Issue 11, Nov. 2014, 11 pages.
- Asadollahi, Sina et al., “Performance comparison of CSMA/CA Advanced Infrared (AIr) and a new point-to-multipoint optical MAC protocol”, 2012 8th International Wireless Communications and Mobile Computing Conference (IWCMC), Abstract Only, Aug. 2012, 2 pages.
- Ascom, “TEMS Pocket—a Complete Measurement Smartphone System in your Hand”, http://www.ascom.us/us-en/tems_pocket_14.0_feature_specific_datasheet.pdf, 2014, 2 pages.
- A-Tech Fabrication, “Dual Antenna Boom Assembly”, http://web.archive.org/web/20090126192215/http://atechfabrication.com/products/dual_antenna_boom.htm, 2009, 2 pages.
- Atlas Sound, “Bi-Axial PA Horn with Gimbal Mount”, MCM Electronics, mcmelectronics.com, 2011, 555-13580.
- Atmel, “Power Line Communications”, www.atmel.com/products/smartenergy/powerlinecommunications/default.aspx, 2015 3 pages.
- Atwater, Harry A., “The promise of plasmonics”, *Scientific American* 296.4, 2007, 56-62.
- “Surface Acoustic Wave (SAW) Touch Screen”, <http://baanto.com/surface-acoustic-wave-saw-touch-screen>, 2016 4 pages.
- Babakhani, Aydin, “Direct antenna modulation (DAM) for on-chip mm-wave transceivers”, *Diss. California Institute of Technology*, 2008, 2 pages.
- Bach, Christian, “Current Sensor—Power Line Monitoring for Energy Demand Control”, *Application Note 308*, http://www.enoccean.com/fileadmin/redaktion/pdf/app_notes/AN308_CURRENT_SENSOR_Jan09.pdf, Jan. 2009, 4 pages.
- Barlow, H. M. et al., “Surface Waves”, 621.396.11 : 538.566, Paper No. 1482 Radio Section, 1953, pp. 329-341.
- Barnes, Heidi et al., “DeMystifying the 28 Gb/s PCB Channel: Design to Measurement”, *Design Con.* 2014, Feb. 28, 2014, 54 pages.
- Barron, Ashleigh L., “Integrated Multicore Fibre Devices for Optical Trapping”, *Diss. Heriot-Watt University*, 2014, 11-15.
- Beal, J.C. et al., “Coaxial-slot surface-wave launcher”, *Electronics Letters* 4.25: 557559, Abstract Only, Dec. 13, 1968, 1 page.
- Benevent, Evangéline, “Transmission lines in MMIC technology”, *Università Mediterranea di Reggio Calabria*, Jan. 28, 2010, 63 pages.
- Beninca “Flashing Light: IR Lamp”, www.beninca.com/en/news/2015/02/23/lampeggiante-irlamp.html, Feb. 23, 2015 4 pages.
- Benkhelifa, Elhadj, “User Profiling for Energy Optimisation in Mobile Cloud Computing”, 2015 1159-1165.
- Berweger, Samuel et al., “Light on the Tip of a Needle: Plasmonic Nanofocusing for Spectroscopy on the Nanoscale”, *The Journal of Physical Chemistry Letters*; pubs.acs.org/JPLCL, 2012, 945-952.
- Bhushan, Naga et al., “Network densification: the dominant theme for wireless evolution into 5G”, *IEEE Communications Magazine*, 52.2., Feb. 2014, 82-89.
- Bing, Benny, “Ubiquitous Broadband Access Networks with Peer-to-Peer Application Support”, *Evolving the Access Network*, 2006, 27-36.
- Blanco-Redondo, Andrea et al., “Coupling midinfrared light from a photonic crystal waveguide to metallic transmission lines”, *Applied Physics Letters* 104.1, 2014, 6 pages.
- Blattenberger, Kirt, “DroneBased Field Measurement System (dBFS)”, *RF Cafe*, rfcafe.com, Jul. 29, 2014, 3 pages.
- Bock, James et al., “Optical coupling”, *Journal of Physics: Conference Series*. vol. 155. No. 1, IOP Publishing, 2009, 32 pages.

(56)

References Cited

OTHER PUBLICATIONS

- Bowen, Leland H. et al., "A Solid Dielectric Lens Impulse Radiating Antenna with High Dielectric Constant Surrounded by a Cylindrical Shroud", Sensor and Simulation Note 498, Introduction, Apr. 2005, 3 pages.
- Brambilla, Gilberto et al., "Ultra-low-loss optical fiber nanotapers", Optoelectronics Research Centre, University of Southampton; <http://www.orc.soton.ac.uk>, vol. 12, No. 10, May 7, 2004, 2258-2263.
- Bridges, Greg E. et al., "Plane wave coupling to multiple conductor transmission lines above a lossy earth", Compatibility, IEEE Transactions on 31.1, Abstract Only, 1989, 21-33.
- Bridges, William B., "Low-Loss Flexible Dielectric Waveguide for Millimeter-Wave Transmission and Its Application to Devices", California Institute of Technology, Office of Naval Research, Mar. 1981, 91 pages.
- Briso-Rodriguez, "Measurements and Modeling of Distributed Antenna Systems in Railway Tunnels", IEEE Transactions on Vehicular Technology, vol. 56, No. 5, Sep. 2007, 2870-2879.
- Brooke, Gary H., "Properties of surface waveguides with discontinuities and perturbations in cross-section", Diss. University of British Columbia, 1977, 42 pages.
- Brown, J. et al., "The launching of radial cylindrical surface waves by a circumferential slot", Proceedings of the IEEE Part B: Radio and Electronic Engineering, vol. 106, Issue 26, Abstract Only, Mar. 1959, 1 page.
- Brown-Iposs, , "Integrated Radio Masts Fully camouflaged Outdoor-Wi-Fi APs in GRP-lamp poles", www.brown-iposs.com, Mar. 21, 2014, 4 pages.
- Bruno, Joseph, "Interference Reduction in Wireless Networks", Computing Research Topics, Computing Sciences Department, Villanova University, Nov. 14, 2007, 8 pages.
- Budde, Matthias, "Using a 2DST Waveguide for Usable, Physically Constrained Out-of-Band Wi-Fi Authentication", <https://pdfs.semanticscholar.org/282e/826938ab7170c198057f9236799e92e21219.pdf>, 2013, 8 pages.
- Burkhart, Martin et al., "Does Topology Control Reduce Interference?", Department of Computer Science, ETH Zurich, Proceedings of the 5th ACM international symposium on Mobile ad hoc networking and computing, 2004, 11 pages.
- Callis, R.W. et al., "An In-Line Power Monitor for HE11 Low Loss Transmission Lines", Proceedings of the 29th International Conference on Infrared and Millimeter Waves (IRMMW), Karlsruhe, Germany, Jun. 2004, 7 pages.
- Campista, Miguel E. et al., "Improving the Data Transmission Throughput Over the Home Electrical Wiring", the IEEE Conference on Local Computer Networks 30th Anniversary, 2005, 1-8.
- Capece, P. et al., "FDTD Analysis of a Circular Coaxial Feeder for Reflector Antenna", Antennas and Propagation Society International Symposium, IEEE Digest, vol. 3, 1997, pp. 1570-1573.
- Carroll, John M. et al., "Developing the Blacksburg Electronic Village", Communications of the ACM, vol. 39, No. 12, Dec. 1996, 69-74.
- Chaimae, Elmakfalji et al., "New Way of Passive RFID Deployment for Smart Grid", Journal of Theoretical and Applied Information Technology 82.1, Dec. 10, 2015 81-84.
- Chen, Dong et al., "A trust management model based on fuzzy reputation for internet of things", Computer Science and Information Systems 8.4: 12071228, Abstract Only, 2011, 1 page.
- Chen, Ke et al., "Geometric phase coded metasurface: from polarization dependent directive electromagnetic wave scattering to diffusionlike scattering", Scientific Reports 6, 2016 1-10.
- Chen, Yingying, "Detecting and Localizing Wireless Spoofing Attacks", Sensor, Mesh and Ad Hoc Communications and Networks, SECON'07, 4th Annual IEEE Communications Society Conference on IEEE, 2007, 10 pages.
- Chiba, Jiro, "Experimental Studies of the Losses and Radiations Due to Bends in the Goubau Line", IEEE Transactions on Microwave Theory and Techniques, Feb. 1977, 94-100.
- Chiba, Jiro, "On the Equivalent Circuit for the G-Line Above Ground", International Wroclaw Symposium on Electromagnetic Compatibility, 1998, 78-82.
- Choudhury, Romit R., "Utilizing Beamforming Antennas for Wireless Mult-hop Networks", www.slideserve.com, Sep. 20, 2012, 4 pages.
- Chu, Eunmi et al., "Self-organizing and self-healing mechanisms in cooperative small cell networks", PIMRC, 2013, 6 pages.
- Cimini, Carlos Alberto et al., "Temperature profile of progressive damaged overhead electrical conductors", Journal of Electrical Power & Energy Systems 49, 2013, 280-286.
- Cisco, , "Troubleshooting Problems Affecting Radio Frequency Communication", cisco.com, Oct. 19, 2009, 5 pages.
- Cliff, Oliver M. et al., "Online localization of radio-tagged wildlife with an autonomous aerial robot system", Proceedings of Robotics Science and Systems XI, 2015 1317.
- Collins, D.D. et al., "Final Report on Advanced Antenna Design Techniques", GER 11246, Report No. 4, Sep. 6, 1963, 1-70.
- Communication Power Solutions, I, , "Power Communication", www.cpspower.biz/services/powercommunications, Oct. 2013, 6 pages.
- Comsol, , "Fast Numerical Modeling of a Conical Horns Lens Antenna", comsol.com, Application ID: 18695, Sep. 16, 2016, 3 pages.
- Corridor Systems, "A New Approach to Outdoor DAS Network Physical Layer Using E-Line Technology", Mar. 2011, 5 pages.
- Costantine, Joseph et al., "The analysis of a reconfigurable antenna with a rotating feed using graph models", Antennas and Wireless Propagation Letters, vol. 8, 2009, 943-946.
- Covington, Michael J. et al., "Threat implications of the internet of things", 2013 5th International Conference on IEEE Cyber Conflict (CyCon), Abstract Only, 2013, 1 page.
- Cradle Point, "Out-of-Band Management", www.cradlepoint.com, Sep. 2015 7 pages.
- Crane, Robert K., "Analysis of the effects of water on the ACTS propagation terminal antenna", Antennas and Propagation, IEEE Transactions on 50.7: 954965, Abstract Only, 2002, 1 page.
- Crisp, "Uplink and Downlink Coverage Improvements of 802.11g Signals Using a Distributed Antenna Network", Journal of Lightwave Technology (vol. 25, Issue: 11), Dec. 6, 2007, 1-4.
- Crosswell, "Aperture excited dielectric antennas", <http://ntrs.nasa.gov/archive/nasa/casi.ntrs.nasa.gov/19740017567.pdf>, 1974, 128 pages.
- CST, "A Dielectric Lens Antenna with Enhanced Aperture Efficiency for Industrial Radar Applications", Computer Simulation Technology, cst.com, May 10, 2011, 3 pages.
- Curry, James M., "A Web of Drones: A 2040 Strategy to Reduce the United States Dependence on Space Based Capabilities", Air War College, Feb. 17, 2015, 34 pages.
- Cypress Perform, , "Powerline Communication", www.cypress.com, Apr. 23, 2015 2 pages.
- Daniel, Kai et al., "Using Public Network Infrastructures for UAV Remote Sensing in Civilian Security Operations", Homeland Security Affairs, Supplement 3, Mar. 2011, 11 pages.
- Darktrace, "www.darktrace.com", Jul. 10, 2014, 4 pages.
- De Freitas, Carvalho et al., "Unmanned Air Vehicle Based Localization and Range Estimation of WiFi Nodes", 2014, 109 pages.
- De Sabata, Aldo et al., "Universitatea "Politehnica"", din Timișoara Facultatea de Electronică și Telecomunicații, 2012, 149 pages.
- DEA+, "24 Volt D.C Flashing Light With Built-in Antenna 433Mhz, DEA+ Product Guide", Meteor electrical, meteorelectrical.com, Code: LUMY/24A, Jul. 28, 2010, 3 pages.
- Debord, Benoit et al., "Generation and confinement of microwave gas-plasma in photonic dielectric microstructure", Optics express 21.21, 2013, 25509-25516.
- Deilmann, Michael, "Silicon oxide permeation barrier coating and sterilization of PET bottles by pulsed low-pressure microwave plasmas", Dissertation, 2008, 142 pages.
- Deng, Chuang et al., "Unmanned Aerial Vehicles for Power Line Inspection: A Cooperative Way in Platforms and Communications", Journal of Communications vol. No. 9, No. 9, Sep. 2014, 687-692.

(56)

References Cited

OTHER PUBLICATIONS

- Winn & Coales (Denso) Ltd. UK, www.denso.net, 2015 1 page.
- Dini, Gianluca et al., "MADAM: A Multilevel Anomaly Detector for Android Malware", *MMMACNS*, vol. 12, 2012, 16 pages.
- Doane, J.L. et al., "Oversized rectangular waveguides with modefree bends and twists for broadband applications", *Microwave Journal* 32(3), Abstract Only, 1989, 153-160.
- Doelitzscher, Frank et al., "ViteraaS: Virtual cluster as a Service", *Cloud Computing Technology and Science (CloudCom)*, 2011 IEEE Third International Conference, 2011, 8 pages.
- Dooley, Kevin , "Out-of-Band Management", *auvik*, auvik.com, Apr. 12, 2014, 5 pages.
- Doshi, D.A. et al., "Real Time Fault Failure Detection in Power Distribution Line using Power Line Communication", *International Journal of Engineering Science*, vol. 6, Issue No. 5, May 2016 4834-4837.
- Dostert, Klaus , "Frequency-hopping spread-spectrum modulation for digital communications over electrical power lines", *Selected Areas in Communications*, *IEEE Journal on* 8.4, Abstract Only, 1990, 700-710.
- Dragoo, R.E. et al., "Fiber Optic Data Bus for the AN/GYQ21(V)", Harris Corp, U.S. Communications Syst. Div. Chart, Microcopy Resolution Test, 1980, 115 pages.
- Dutton, Harry J. , "Understanding Optical Communications", International Technical Support Organization, SG24-5230-00, Sep. 1998, 55 pages.
- Dyson, John D. , "The Equiangular Spiral Antenna", *IRE Transactions on Antennas and Propagation*, 1959, 181-187.
- Earth Data, "Remote Sensors", NASA, earthdata.nasa.gov, Oct. 17, 2016 36 pages.
- Ehyaie, Danial , "Novel Approaches to the Design of Phased Array Antennas", Diss., The University of Michigan, 2011, 153 pages.
- Eizo, , "How can a screen sense touch? A basic understanding of touch panels", www.eizo.com/library/basics/basic_understanding_of_touch_panel, Sep. 27, 2010, 8 pages.
- Ekstrom, "Slot-line end-fire antennas for THz frequencies", *Third International Symposium on Space Terahertz Technology*, 280-290.
- Electric Power Research Institut, "Examination of the Exacter Outage-Avoidance System", www.epri.com/abstracts/Pages/ProductAbstract.aspx?ProductId=00000000001020393, Nov. 30, 2009, 2 pages.
- Eline Corridor Systems, "How is ELine Different?", www.corridor.biz/ELine_is_different.html, Apr. 23, 2015, 1 page.
- Elmore, Glenn et al., "A Surface Wave Transmission Line", *QEX*, May/June. 2012, pp. 3-9.
- Elmore, Glenn , "Introduction to the Propagating Wave on a Single Conductor", www.corridor.biz, Jul. 27, 2009, 30 pages.
- Emerson, "About Rosemount 5300 Level Transmitter", www.emerson.com, Nov. 2016 6 pages.
- Eom, Seung-Hyun et al., "Pattern switchable antenna system using inkjet-printed directional bow-tie for bi-direction sensing applications", *Sensors* 15.12, 2015 31171-31179.
- EPRI—Electronic Power Research, "Product Abstract—Program on Technology Innovation: Study on the Integration of High Temperature Superconducting DC Cables Within the Eastern and Western North American Power Grids", epri.com, Product ID:10203, Nov. 25, 2009, 2 pages.
- Erickson, Katherine , "Conductive cylindrical surface waveguides", www.ideals.illinois.edu/bitstream/handle/2142/30914/Erickson_Katherine.pdf?sequence=1, 2012, 74 pages.
- Ericsson, "Direct Bury Duct Assemblies, MPB 302 3+—Ribbonet Microducts", www.archive.ericsson.net, Jul. 30, 2014, 2 pages.
- Eskelinen, Harri et al., "DFM (A)—aspects for a horn antenna design", *Lappeenranta University of Technology*, 2004, 34 pages.
- Eskelinen, P. , "A low-cost microwave rotary joint", *International Radar Conference*, 13-17, Abstract Only, Oct. 2014, 1-4.
- Faggiani, Adriano , "Smartphone-based crowdsourcing for network monitoring: opportunities, challenges, and a case study", <http://vecchio.iet.unipi.it/vecchio/files/2010/02/article.pdf>, 2014, 8 pages.
- Farr Research, Inc., "An Improved Solid Dielectric Lens Impulse Radiating Antenna", *SBIR/STTR, DoD*, sbir.gov, 2004, 3 pages.
- Farzaneh, Masoud et al., "Systems for Prediction and Monitoring of Ice Shedding, Anti-Cicing and De-Icing for Power Line Conductors and Ground Wires", Dec. 1, 2010, 1-100.
- Fattah, E. Abdel et al., "Numerical 3D simulation of surface wave excitation in planar-type plasma processing device with a corrugated dielectric plate", *Elsevier, Vacuum* 86, 2011, 330-334.
- Feko, "Lens Antennas", *Altair*, feko.info, Jun. 30, 2014, 2 pages.
- Feko, "mmWave Axial Choke Horn Antenna with Lens", Sep. 24, 2013, 2 pages.
- Feng, Taiming et al., "Design of a survivable hybrid wireless-optical broadband-access network", *Journal of Optical Communications and Networking* 3.5, 2011, 458-464.
- Feng, Wei et al., "Downlink power allocation for distributed antenna systems in a multi-cell environment", *2009 5th International Conference on Wireless Communications, Networking and Mobile Computing*, 2009, 2 pages.
- Fenn, Alan J. et al., "A Terrestrial Air Link for Evaluating Dual-Polarization Techniques in Satellite Communications", vol. 9, No. 1, *The Lincoln Laboratory Journal*, 1996, 3-18.
- Fenye, Bao et al., "Dynamic trust management for internet of things applications", *Proceedings of the 2012 international workshop on Selfaware internet of things*, *ACM*, Abstract Only, 2012, 1 page.
- Fiorelli, Riccardo et al., "ST7580 power line communication systemonchip design guide", Doc ID 022923 Rev 2, Jul. 2012, 63 pages.
- Firelight Media Group, "About Firelight Media Group", www.insurancetechnologies.com/Products/Products_firelight_overview.html, Apr. 19, 2015 4 pages.
- Firelight Media Group LLC, "Electronic Business Fulfillment FireLight", www.firelightmedia.net/fmg/index.php/home, Apr. 19, 2015 2 pages.
- Fitzgerald, William D. , "A 35-GHz Beam Waveguide System for the Millimeter-Wave Radar", *The Lincoln Laboratory Journal*, vol. 5, No. 2, 1992, 245-272.
- Ford, Steven , "AT&T's new antenna system will boost cellular coverage at Walt Disney World", *Orlando Sentinel*, orlandosentinel.com, Mar. 9, 2014, 4 pages.
- Freyer, Dan et al., "Combating the Challenges of Ka-Band Signal Degradation", *SatMagazine*, satmagazine.com, Sep. 2014, 9 pages.
- Friedman, M et al., "Low-loss RF transport over long distances", *IEEE Transactions on Microwave Theory and Techniques*, Jan. 1, 2001, 341-348.
- Friedman, M et al., "Low-Loss RF Transport Over Long Distances", *IEEE Transactions on Microwave Theory and Techniques*, vol. 49, No. 2, Feb. 2001, 8 pages.
- Friedman, M. et al., "Low-Loss RF Transport Over Long Distances", *IEEE Transactions on Microwave Theory and Techniques*, vol. 49, No. 2, Feb. 2001, 341-348.
- Fromm, W. et al., "A new microwave rotary joint", *1958 IRE International Convention Record*, 21-25, 6:78-82, Abstract Only, Mar. 1966, 2 pages.
- Galli, "For the Grid and Through the Grid: The Role of Power Line Communications in the Smart Grid", *Proceedings of the IEEE* 99.6, Jun. 2011, 1-26.
- Garcia-Etxarri, Aitzol et al., "A combination of concave/convex surfaces for fieldenhancement optimization: the indented nanocone", *Optics express* 20.23, 2012, 2520125212.
- Gerini, Giampiero , "Multilayer array antennas with integrated frequency selective surfaces conformal to a circular cylindrical surface", <http://alexandria.tue.nl/openaccess/Metis248614.pdf>, 2005, 2020-2030.
- Geterud, Erik G. , "Design and Optimization of Wideband Hat-Fed Reflector Antenna with Radome for Satellite Earth Station", <http://publications.lib.chalmers.se/records/fulltext/163718.pdf>, Discloses Frequency Selective Surfaces for antenna coverings for weather protection (table of materials on p. 29-30; pp. 37-46), 2012, 70 pages.
- Ghazisaidi, Navid et al., "Survivability analysis of next-generation passive optical networks and fiber-wireless access networks", *Reliability, IEEE Transactions on* 60.2, 2011, 479-492.

(56)

References Cited

OTHER PUBLICATIONS

- Gigamon, "Out-of-Band Security Solution", www.gigamon.com, Aug. 3, 2014, 7 pages.
- Gilbert, Barrie et al., "The Gears of Genius", IEEE SolidState Circuits Newsletter 4.12, 2007, 10-28.
- Glockler, Roman, "Phased Array for Millimeter Wave Frequencies", International Journal of Infrared and Millimeter Waves, Springer, vol. 11, No. 2, Feb. 1, 1990, 10 pages.
- Godara, "Applications of Antenna Arrays to Mobile Communications, Part I: Performance Improvement, Feasibility, and System Considerations", Proceedings of the IEEE, vol. 85, No. 7, Jul. 1997, 1031-1060.
- Goldsmith, Paul F., "Quasi-optical techniques", Proceedings of the IEEE, vol. 80, No. 11, Nov. 1, 1992, 1729-1747.
- Golrezaei, Negin et al., "FemtoCaching: Wireless Video Content Delivery through Distributed Caching Helpers", INFOCOM, Proceedings IEEE, 2012, 9 pages.
- Gomes, Nathan J. et al., "Radio-over-fiber transport for the support of wireless broadband services", Journal of Optical Networking, vol. 8, No. 2, 2009, 156-178.
- Gonthier, François et al., "Mode coupling in nonuniform fibers: comparison between coupled-mode theory and finite-difference beam-propagation method simulations", JOSA B 8.2: 416421, Abstract Only, 1991, 3 pages.
- Greco, R., "Soil water content inverse profiling from single TDR waveforms", Journal of hydrology 317.3, 2006, 325-339.
- Gritzalis, Dimitris et al., "The Sphinx enigma in critical VoIP infrastructures: Human or botnet?", Information, Intelligence, Systems and Applications (IISA), 2013 Fourth International Conference, IEEE, 2013, 6 pages.
- Gunduz, Deniz et al., "The multiway relay channel", IEEE Transactions on Information Theory 59.1, 2013, 5163.
- Guo, Shuo et al., "Detecting Faulty Nodes with Data Errors for Wireless Sensor Networks", 2014, 25 pages.
- Hadi, Ghazali S. et al., "Autonomous UAV System Development for Payload Dropping Mission", The Journal of Instrumentation, Automation and Systems, vol. 1, No. 2, 2014, pp. 72-22.
- Hafeez, "Smart Home Area Networks Protocols within the Smart Grid Context", Journal of Communications vol. 9, No. 9, Sep. 2014, 665-671.
- Haider, Muhammad Kumail et al., "Mobility resilience and overhead constrained adaptation in directional 60 GHz WLANs: protocol design and system implementation", Proceedings of the 17th ACM International Symposium on Mobile Ad Hoc Networking and Computing, 2016 10 pages.
- Halder, Achintya et al., "Low-cost alternate EVM test for wireless receiver systems", 23rd IEEE VLSI Test Symposium (VTS'05), 2005, 6 pages.
- Hale, Paul et al., "A statistical study of deembedding applied to eye diagram analysis", IEEE Transactions on Instrumentation and Measurement 61.2, 2012, 475-488.
- Halligan, Matthew S., "Maximum crosstalk estimation and modeling of electromagnetic radiation from PCB/highdensity connector interfaces", http://scholarsmine.mst.edu/cgi/viewcontent.cgi?article=3326&context=doctoral_dissertations, 2014, 251 pages.
- Han, Chong et al., "crosslayer communication module for the Internet of Things", Computer Networks 57.3: 622633, Abstract Only, 2013, 1 page.
- Hanashi, Abdalla M. et al., "Effect of the Dish Angle on the Wet Antenna Attenuation", IEEE, 2014, 1-4.
- Haroun, Ibrahim et al., "WLANs meet fiber optics-Evaluating 802.11 a WLANs over fiber optics links", www.rfdesign.com, 2003, 36-39.
- Hassan, Karim, "Fabrication and characterization of thermo-plasmonic routers for telecom applications", Diss. Univ. de Bourgogne., 2014, 59 pages.
- Hassan, Maaly A., "Interference reduction in mobile ad hoc and sensor networks", Journal of Engineering and Computer Innovations vol. 2(7), Sep. 2011, 138-154.
- Hassani, Alireza et al., "Porous polymer fibers for low-loss Terahertz guiding", Optics express 16.9, 2008, 6340-6351.
- Hautakorpi, Jani et al., "Requirements from Session Initiation Protocol (SIP) Session Border Control (SBC) Deployments", RFC5853, IETF, 2010, 27 pages.
- Hawrylyshen, A. et al., "SIPPING Working Group", J. Hautakorpi, Ed. Internet—Draft G. Camarillo Intended status: Informational Ericsson Expires: Dec. 18, 2008 R. Penfield Acme Packet, Oct. 23, 2008, 26 pages.
- Hays, Phillip, "SPG-49 Tracking Radar", www.okieboat.com/SPG-49%20description.html, 2015 15 pages.
- Heo, Joon et al., "Identity-Based Mutual Device Authentication Schemes for PLC Systems", IEEE International Symposium on Power Line Communications and Its Applications, 2008, pp. 47-51.
- Hoss, R.J. et al., "Manufacturing Methods and Technology Program for Ruggedized Tactical Fiber Optic Cable", No. ITT-80-03-078. ITT Electrooptical Products Div Roanoke VA., 1980, 69 pages.
- Howard, Courtney, "UAV command, control & communications", Military & Aerospace Electronics, militaryaerospace.com, Jul. 11, 2013, 15 pages.
- Hussain, Mohamed T. et al., "Closely Packed Millimeter-Wave MIMO Antenna Arrays with Dielectric Resonator Elements", Antennas and Propagation (EuCAP) 2016 10th European Conference, Apr. 2016 1-5.
- Huth, G. K., "Integrated source and channel encoded digital communication system design study", <http://ntrs.nasa.gov/archive/nasa/casi.ntrs.nasa.gov/19750003064.pdf>, 1974, 65 pages.
- Ikrath, K. et al., "Antenna Innovation Glass-Fiber Tube Focuses Microwave Beam", Electronics, vol. 35, No. 38, Sep. 21, 1962, 44-47.
- Illinois Historic Archive, "Antennas on the Web", Photo Archive of Antennas, ecc.illinois.ed, 1-18, Dec. 2016.
- Industrial Fiber Optics, "Asahi Multi-Core Fiber Cable", <http://i-fiberoptics.com/multi-core-fiber-cable.php>, Apr. 26, 2015 2 pages.
- Infoexpress, "Detecting and Preventing MAC Spoofing", Network Access Control Solutions, 2014, 1 page.
- Ippolito, Louis J., "Propagation effects handbook for satellite systems design. A summary of propagation impairments on 10 to 100 GHz satellite links with techniques for system design", 1989, Abstract Only, 1989, 1 page.
- Islam, M. T., "Coplanar Waveguide Fed Microstrip Patch Antenna", Information Technology Journal 9.2 (2010): 367-370., 2010, 367-370.
- Izumiya, Hidetaka et al., "Multicast over satellite", Applications and the Internet, (SAINT 2002), IEEE Proceedings, 2002, 4 pages.
- Jackson, Mark, "Timico CTO Hit by Slow FTTC Broadband Speeds After Copper Corrosion", www.ispreview.co.uk, Mar. 5, 2013, 2 pages.
- Jaeger, Raymond et al., "Radiation Performance of Germanium Phosphosilicate Optical Fibers", RADC-TR-81-69: Final Technical Report, Galileo Electro-Optical Corp, May 1981, 101 pages.
- James, Graeme L. et al., "Diplexing Feed Assemblies for Application to Dual-Reflector Antennas", IEEE Transactions on Antennas and Propagation, vol. 51, No. 5, May 2003, 1024-1029.
- James, J. R. et al., "Investigations and Comparisons of New Types of Millimetre-Wave Planar Arrays Using Microstrip and Dielectric Structures", Royal Military College of Science, Apr. 1985, 122 pages.
- Jang, Hung-Chin, "Applications of Geometric Algorithms to Reduce Interference in Wireless Mesh Network", Journal on Applications of Graph Theory in Wireless Ad hoc Networks and Sensor Networks (JGRAPH-HOC) vol. 2, No. 1, Abstract Only, Mar. 2010, 1 page.
- Jawhar, Imad et al., "A hierarchical and topological classification of linear sensor networks", Wireless Telecommunications Symposium, WTS, IEEE, http://faculty.uaeu.ac.ae/Nader_M/papers/WTS2009.pdf, 2009, 8 pages.
- Lee, George et al., "Demonstration of the Technical Viability of PLC Systems on Medium- and Low-Voltage Lines in the United States", Broadband is Power: Internet Access Via Power Line Networks, IEEE Communication Magazine, May 2003, 5 pages.

(56)

References Cited

OTHER PUBLICATIONS

- Jensen, Michael , "Data-Dependent Fingerprints for Wireless Device Authentication", www.dtic.mil/cgi-bin/GetTRDoc?AD=ADA626320, 2014, 15 pages.
- Jeong, et al., "Study of elliptical polarization requirement of KSTAR 84-GHz ECH system", *Journal of the Korean Physical Society*, vol. 49, Dec. 2006, 201-205.
- Jiang, Peng , "A New Method for Node Fault Detection in Wireless Sensor Networks", 2009, 1282-1294.
- Jiang, Y.S. et al., "Electromagnetic orbital angular momentum in remote sensing", *PIERS Proceedings, Moscow, Russia*, Aug. 18-21, 2009, 1330-1337.
- Jin, "Quasi-optical mode converter for a coaxial cavity gyrotron", *Forschungszentrum Karlsruhe*, Mar. 2007, 107 pages.
- Jin, Yu et al., "Nevermind, the Problem Is Already Fixed: Proactively Detecting and Troubleshooting Customer DSL Problems", *ACM CoNEXT, Philadelphia, USA*, Nov.-Dec. 2010, 12 pages.
- Jones, Jr., Howard S. , "Conformal and Small Antenna Designs", *U.S. Army Electronics Research and Development Command, Harry Diamond Laboratories*, Apr. 1981, 32 pages.
- Kado, Yuichi et al., "Exploring SubTHz Waves for Communications, Imaging, and Gas Sensing", *Fog 2: O2, PIERS Proceedings, Beijing, China*, Mar. 23-27, 2009, 42-47.
- Kamilaris, Andreas et al., "Exploring the Use of DNS as a Search Engine for the Web of Things", *Internet of Things (WF-IoT), 2014 IEEE World Forum*, 2014, 6 pages.
- Kang, Eyung W. , "Chapter 6: Array Antennas", www.globalspec.com/reference/75109/203279/chapter-6-array-antennas, Apr. 22, 2015 2 pages.
- Karbowiak, A. E. et al., "Characteristics of Waveguides for Long-Distance Transmission", *Journal of Research of the National Bureau of Standards*, vol. 65D, No. 1, Jan.-Feb. 1961, May 23, 1960, 75-88.
- Katkovnik, Vladimir et al., "High-resolution signal processing for a switch antenna array FMCW radar with a single channel receiver", *2002 IEEE Sensor Array and Multichannel Signal Processing Workshop Proceedings*, 2002, 6 pages.
- Katrasnik, Jaka , "New Robot for Power Line Inspection", *2008 IEEE Conference on Robotics, Automation and Mechatronics*, 2008, 1-6.
- Kedar, "Wide Beam Tapered Slot Antenna for Wide Angle Scanning Phased Array Antenna", *Progress in Electromagnetics Research B*, vol. 27, 2011, 235-251.
- Khan, Kaleemullah , "Authentication in Multi-Hop Wireless Mesh Networks", *World Academy of Science, Engineering and Technology, International Journal of Electrical, Computer, Energetic, Electronic and Communication Engineering* vol. 2, No. 10, 2008, 2406-2411.
- Khan, Mohammed R. , "A beam steering technique using dielectric wedges", *Diss. University of London*, Dec. 1985, 3 pages.
- Khan, Ubaid Mahmood et al., "Dual polarized dielectric resonator antennas", *Chalmers University of Technology*, Jun. 2010, 128 pages.
- Kikuchi, H. et al., "Hybrid transmission mode of Goubau lines", *J.Inst.Electr.Comm.Engrs.*, Japan, vol. 43, 1960, 39-45.
- Kim, Jong-Hyuk et al., "Real-time Navigation, Guidance, and Control of a UAV using Low-cost Sensors", *Australian Centre for Field Robotics*, Mar. 5, 2011, 6 pages.
- Kim, Myungsik et al., "Automated RFID-based identification system for steel coils", *Progress in Electromagnetics Research* 131, 2012, 1-17.
- Kima, Yi-Gon et al., "Generating and detecting torsional guided waves using magnetostrictive sensors of crossed coils", *Chonnam National University, Republic of Korea, Elsevier Ltd.*, 2010, 145-151.
- Kirkham, H. et al., "Power system applications of fiber optics (Jet Propulsion Lab)", *JPL Publication 84-28, Electric Energy Systems Division, U.S. DoE*, 1984, 180.
- Kleinrock, Leonard et al., "On measured behavior of the ARPA network", *National Computer Conference*, 1974, 767-780.
- Kliros, George S. , "Dielectric-EBG covered conical antenna for UWB applications", www.researchgate.net/profile/George_Kliros/publication/235322849_Dielectric-EBG_covered_conical_antenna_for_UWB_applications/links/54329e410cf225bddcc7c037.pdf, 2010, 10 pages.
- Koga, Hisao et al., "High-Speed Power Line Communication System Based on Wavelet OFDM", *7th International Symposium on Power-Line Communications and Its Applications*, Mar. 26-28, 2003, 226-231.
- Kolpakov, Stanislav A. et al., "Toward a new generation of photonic humidity sensors", *Sensors* 14.3, 2014, 3986-4013.
- Koshiba, Masanori et al., "Analytical expression of average power-coupling coefficients for estimating intercore crosstalk in multicore fibers", *Photonics Journal, IEEE* 4.5, 2012, 1987-1995.
- Kroon, Barnard et al., "Steady state RF fingerprinting for identity verification: one class classifier versus customized ensemble", *Artificial Intelligence and Cognitive Science. Springer Berlin Heidelberg*, 198206, Abstract Only, 2010, 3 pages.
- Kroyer, Thomas , "A Waveguide High Order Mode Reflectometer for the Large Hadron Collider Beam-pipe", *Diss. TU Wien.*, 2003, 76 pages.
- Kuehn, E , "Self-configuration and self-optimization of 4G Radio Access Networks", http://wirelessman.org/tgm/contrib/S80216m-07_169.pdf, 2007, 13 pages.
- Kuhn, Marc et al., "Power Line Enhanced Cooperative Wireless Communications", *IEEE Journal on Selected Areas in Communications*, vol. 24, No. 7, Jul. 2006, 10 pages.
- Kumar, Sailesh , "Survey of Current Network Intrusion Detection Techniques", *Washington Univ. in St. Louis*, Dec. 2007, 18 pages.
- Kune, Denis F. et al., "Ghost Talk: Mitigating EMI Signal Injection Attacks against Analog Sensors", *IEEE Symposium on Security and Privacy*, 2013, 145-159.
- Laforte, J.L. et al., "State-of-the-art on power line de-icing", *Atmospheric Research* 46, 1998, 143-158.
- Lairdtech, "Allpurpose Mount Kit", www.lairdtech.com, Mar. 29, 2015 2 pages.
- Lappgroupusa, "Selection of Number of Cable Cores With Emphasis on Sizing Parameters", *Industrial Cable & Connector Technology News*, lappconnect.blogspot.com, http://lappconnect.blogspot.com/2014_10_01_archive.html, Oct. 30, 2014, 4 pages.
- Lazaropoulos, Athanasios , "Towards Modal Integration of Overhead and Underground Low-Voltage and Medium-Voltage Power Line Communication Channels in the Smart Grid Landscape: Model Expansion, Broadband Signal Transmission Characteristics, and Statistical Performance Metrics", *International Scholarly Research Network, ISRN Signal Processing*, vol. 2012, Article ID 121628, 17 pages, Mar. 26, 2012, 18 pages.
- Lazaropoulos, Athanasios G. , "Wireless sensor network design for transmission line monitoring, metering, and controlling: introducing broadband over power lines-enhanced network model (BPLeNM)", *ISRN Power Engineering*, 2014, 23 pages.
- Lee, Joseph C. , "A Compact Q-/K-Band Dual Frequency Feed Horn", No. TR-645, *Massachusetts Institute of Technology, Lincoln Laboratory*, May 3, 1983, 40 pages.
- Lee, Sung-Woo , "Mutual Coupling Considerations in the Development of Multi-feed Antenna Systems", <http://ntrs.nasa.gov/archive/nasa/casi.ntrs.nasa.gov/19750003064.pdf>, 2008, 127 pages.
- Leech, Jamie et al., "Experimental investigation of a low-cost, high performance focal-plane horn array", *Terahertz Science and Technology, IEEE Transactions on* 2.1, 2012, 61-70.
- Li, Mo et al., "Underground structure monitoring with wireless sensor networks", *Proceedings of the 6th international conference on Information processing in sensor networks, ACM*, 2007, 69-78.
- Li, Xi et al., "A FCM-Based peer grouping scheme for node failure recovery in wireless P2P file sharing", *2009 IEEE International Conference on Communications*, 2009, 2 pages.
- Li, Xiang-Yang et al., "Interference-Aware Topology Control for Wireless Sensor Networks", *SECON*. vol. 5, 2005, 12 pages.
- Li, Xiaowei et al., "Integrated plasmonic semi-circular launcher for dielectric-loaded surface plasmonpolariton waveguide", *Optics Express*, vol. 19, Issue 7, 2011, 6541-6548.
- Li, Xu et al., "Smart community: an internet of things application", *Communications Magazine, IEEE* 49.11, Nov. 2011, 68-75.

(56) **References Cited**

OTHER PUBLICATIONS

- Liang, Bin, "Cylindrical Slot FSS Configuration for Beam-Switching Applications", *IEEE Transactions on Antennas and Propagation*, vol. 63, No. 1, Jan. 2015 166-173.
- Lier, E. et al., "Simple hybrid mode horn feed loaded with a dielectric cone", *Electronics Letters* 21.13: 563564, 1985, 563-564.
- Lier, Erik, "A Dielectric Hybrid Mode Antenna Feed: A Simple Alternative to the Corrugated Horn", *IEEE Transactions on Antennas and Propagation*, vol. AP-34, No. 1, Jan. 1986, 21-30.
- Lim, Christina et al., "Fiber-wireless networks and subsystem technologies", *Lightwave Technology, Journal of* 28.4, Feb. 5, 2010, 390-405.
- Liu, et al., "A 25 Gb/s (km^2) urban wireless network beyond IMT-Advanced", *IEEE Communications Magazine* 49.2, 2011, 122-129.
- Lou, Tiancheng, "Minimizing Average Interference through Topology Control", *Algorithms for Sensor Systems*, Springer Berlin Heidelberg, 2012, 115-129.
- L-TEL: Quanzhou L-TEL Communicat., "Products: GSM Micro Repeater", www.l-tel.com, Apr. 24, 2015 3 pages.
- Lucyszyn, S. et al., "Novel RF MEMS Switches", *Proceedings of Asia-Pacific Microwave Conference 2007*, 2007, 55-58.
- Lucyszyn, Stepan et al., "RF MEMS for antenna applications", 7th European Conference on Antennas and Propagation (EUCAP 2103), 2013, 1988-1992.
- Lumerical Solutions, Inc., "Tapered waveguide", www.docs.lumerical.com, 2010, 3 pages.
- Lumerical Solutions, Inc., "Waveguide Bragg Microcavity", www.lumerical.com, Sep. 2016 6 pages.
- Luo, Hailu et al., "Reversed propagation dynamics of Laguerre-Gaussian beams in left-handed materials", *Physical Review A* 77.2, 023812., Feb. 20, 2008, 1-7.
- Luo, Qi et al., "Circularly polarized antennas", John Wiley & Sons, Book—description only, 2013, 1 page.
- Mahato, Suvranshu Sekhar, "Studies on an Infrared Sensor Based Wireless Mesh Network. Diss.", Abstract Only, 2010, 2 pages.
- Maier, Martin et al., "The Audacity of Fiberwireless (FiWi) Networks", *AccessNets*, 2009, 16-35.
- Makwana, G. D. et al., "Wideband Stacked Rectangular Dielectric Resonator Antenna at 5.2 GHz", *International Journal of Electromagnetics and Applications* 2012, 2(3), 2012, 41-45.
- Marcanti, E.A. et al., "Hollow Metallic and Dielectric Waveguides for Long Distance Optical Transmission and Lasers", *Bell System Technical Journal* 43(4), Abstract Only, 2 pages, 1964, 1783-1809.
- Marin, Leandro, "Optimized ECC Implementation for Secure Communication between Heterogeneous IoT Devices", www.mdpi.com/1424-8220/15/9/21478/pdf, 2015 21478-21499.
- Marrucci, Lorenzo, "Rotating light with light: Generation of helical modes of light by spin-to-orbital angular momentum conversion in inhomogeneous liquid crystals", *International Congress on Optics and Optoelectronics. International Society for Optics and Photonics*, 2007, 12 pages.
- Marzetta, "Noncooperative Cellular Wireless with Unlimited Numbers of Base Station Antennas", *IEEE Transactions on Wireless Communications*, vol. 9, No. 11, Nov. 2010, 3590-3600.
- Matsukawa, et al., "A dynamic channel assignment scheme for distributed antenna networks", *Vehicular Technology Conference (VTC Spring)*, 2012 IEEE 75th, 2012, 5 pages.
- McAllister, M.W. et al., "Resonant hemispherical dielectric antenna", *Electronics Letters* 20.16: 657659, Abstract Only, 1984, 1 page.
- Meessen, A., "Production of EM Surface Waves by Superconducting Spheres: A New Type of Harmonic Oscillators", *Progress in Electromagnetics Research Symposium Proceedings, Moscow, Russia*, Aug. 19-23, 2012, pp. 529-533.
- Mehta, "Advance Featuring Smart Energy Meter With Bi-Directional Communication", *Electronics & Communication MEEGI*, Feb. 9, 2014, 169-174.
- Mena, F.P. et al., "Design and Performance of a 600720GHz Sideband Separating Receiver Using and AIN SIS Junctions", *IEEE Transactions on Microwave Theory and Techniques* 59.1, 2011, 166-177.
- Meng, H. et al., "A transmission line model for high-frequency power line communication channel", *Power System Technology, PowerCon 2002, International Conference on IEEE*, vol. 2, 2002, 6 pages.
- Menon, S.S. et al., "Propagation characteristics of guided modes in a solid dielectric pyramidal horn", *Proceedings of the 2012 International Conference on Communication Systems and Network Technologies*, IEEE Computer Society, Abstract Only, 2012, 2 pages.
- Microwave Technologies, Ind., "Dielectric Antenna", www.microwavetechnologiesinc.co.in/microwavecommunicationlabproducts.html#dielectricantenna, May 21, 2015 13 pages.
- Miller, Ashley et al., "Pathway to Ubiquitous Broadband: Environments, Policies, and Technologies to Implementation", Oct. 2016 20 pages.
- Miller, David A., "Establishing Optimal Wave Communication Channels Automatically", *Journal of Lightwave Technology*, vol. 31, No. 24, Dec. 15, 2013, 3987-3994.
- Mishra, Sumita et al., "Load Balancing Optimization in LTE/LTE-A Cellular Networks: A Review", *arXiv preprint arXiv:1412.7273* (2014), 2014, 1-7.
- Mitchell, John E., "Integrated Wireless Backhaul Over Optical Access Networks", *Journal of Lightwave Technology* 32.20, 2014, 3373-3382.
- Miyagi, M., "Bending losses in hollow and dielectric tube leaky waveguides", *Applied Optics* 20(7), Abstract Only, 2 pages, 1981, 1221-1229.
- Moaveni-Nejad, Kousha et al., "Low-Interference Topology Control for Wireless Ad Hoc Networks", *Department of Computer Science, Illinois Institute of Technology, Ad Hoc & Sensor Wireless Networks* 1.1-2, 2005, 41-64.
- Moisan, M. et al., "Plasma sources based on the propagation of electromagnetic surface waves", *Journal of Physics D: Applied Physics* 24, 1991, 1025-1048.
- Mokhtarian, Kianoosh et al., "Caching in Video CDNs: Building Strong Lines of Defense", *EuroSys, Amsterdam, Netherlands*, 2014, 13 pages.
- Mori, A. et al., "The Power Line Transmission Characteristics for an OFDM Signal", *Progress in Electromagnetics Research*, Pier 61, Musashi Institute of Technology, 2006, 279-290.
- Morse, T.F., "Research Support for the Laboratory for Lightwave Technology", *Brown Univ Providence RI Div of Engineering*, 1992, 32 pages.
- Mruk, Joseph Rene, "Wideband monolithically integrated frontend subsystems and components", *Diss. University of Colorado*, 2011, 166 pages.
- Mueller, G.E. et al., "Polyrod Antennas", *Bell System Technical Journal*, vol. 26., No. 4, Oct. 29, 1947, 837-851.
- Mushref, Muhammad, "Matrix solution to electromagnetic scattering by a conducting cylinder with an eccentric metamaterial coating", www.sciencedirect.com/science/article/pii/S0022247X06011450/pdf?md5=4823be0348a3771b5cec9ffb7f326c2c&pid=1-s2.0-S0022247X06011450-main.pdf, Discloses controlling antenna radiation pattern with coatings, 2007, 356-366.
- Mwave, "Dual Linear C-Band Horn", www.mwavelc.com/custom-Band-LS-BandTelemetryHornAntennas.php, Jul. 6, 2012, 1 page.
- Nakano, Hisamatsu, "A Low-Profile Conical Beam Loop Antenna with an Electromagnetically Coupled Feed System", [http://repo.lib.hosei.ac.jp/bitstream/10114/3835/1/31_TAP\(Low-Profile\).pdf](http://repo.lib.hosei.ac.jp/bitstream/10114/3835/1/31_TAP(Low-Profile).pdf), Dec. 2000, 1864-1866.
- Nakano, Hisamatsu et al., "A Spiral Antenna Backed by a Conducting Plane Reflector", *IEEE Transactions on Antennas and Propagation*, vol. AP-34 No. 6, Jun. 1986, 791-796.
- Nandi, Somen et al., "Computing for rural empowerment: enabled by last-mile telecommunications", *IEEE Communications Magazine* 54.6, 2016 102-109.

(56)

References Cited

OTHER PUBLICATIONS

- Narayanan, Arvind, "Fingerprinting of RFID Tags and HighTech Stalking", 33 Bits of Entropy, 33bits.org, Oct. 4, 2011, 4 pages.
- Nassa, Vinay Kumar, "Wireless Communications: Past, Present and Future", Dronacharya Research Journal: 50. vol. III, Issue—II, Jul.-Dec. 2011, 2011, 96 pages.
- Nassar, , "Local Utility Powerline Communications in the 3-500 kHz Band: Channel Impairments, Noise, and Standards", IEEE Signal Processing Magazine, 2012, 1-22.
- NBNTM, "Network technology", nbnc.com.au, Jun. 27, 2014, 2 pages.
- Netgear, , "Powerline—Juice Up Your Network With Powerline", www.netgear.com/home/products/networking/powerline, Apr. 21, 2015 3 pages.
- Newmark System, Inc "GM-12 Gimbal Mount", newmarksystems.com, 2015 1 page.
- Nibarger, John P. , "An 84 pixel all-silicon corrugated feedhorn for CMB measurements", Journal of Low Temperature Physics 167.3-4, 2012, 522-527.
- Nicholson, Basil J. , "Microwave Rotary Joints for X-, C-, and S-band", Battelle Memorial Inst Columbus OH, 1965, 51 pages.
- Niedermayer, Uwe et al., "Analytic modeling, simulation and interpretation of broadband beam coupling impedance bench measurements", Nuclear Instruments and Methods in Physics Research Section A: Accelerators, Spectrometers, Detectors and Associated Equipment 776, 2015 129-143.
- Nikitin, A. Y. et al., "Efficient Coupling of Light to Graphene Plasmons by Compressing Surface Polaritons with Tapered Bulk Materials", NanoLetters; pubs.acs.org/NanoLett, Apr. 28, 2014, 2896-2901.
- Nikitin, Pavel V. et al., "Propagation Model for the HVAC Duct as a Communication Channel", IEEE Transactions on Antennas and Propagation 51.5, 2003, 7 pages.
- Norse Appliance, "Block attacks before they target your network, and dramatically improve the ROI on your entire security infrastructure", norsecorp.com, 2015 4 pages.
- Nuvotronics, , "PolyStrata—Phased Arrays & Antennas", Nuvotronics, www.nuvotronics.com/antennas.php, Apr. 26, 2015 1 page.
- Nwclimate, , "Weather Instruments and Equipment Explained", nwclimate.org, May 7, 2015 22 pages.
- OECD, , "Alternative Local Loop Technologies: A Review", Organisation for Economic Co-Operation and Development, Paris, https://www.oecd.org/sti/2090965.pdf, 1996, 25 pages.
- Ohliger, Michael, "An introduction to coil array design for parallel MRI", http://mriquestions.com/uploads/3/4/5/7/34572113/intro_to_coil_design_parallel_.pdf, 2006, 16 pages.
- Olver, A. D. , "Microwave horns and feeds", vol. 39. IET, Book—description only, 1994, 1 page.
- Olver, A.D. et al., "Dielectric cone loaded horn antennas", Microwaves, Antennas and Propagation, IEEE Proceedings H. vol. 135. No. 3. IET, Abstract Only, 1988, 1 page.
- Opengear, "Smart Out-Of-Band Management", www.opengear.com, Sep. 2015 2 pages.
- Orfanidis, Sophocles J. , "Antenna Arrays", Rutgers University, 2002, 910-939.
- Pahlavan, Kaveh et al., "Wireless data communications", Proceedings of the IEEE 82.9, 1994, 1398-1430.
- Paruchuri, et al., "Securing Powerline Communication", IEEE, 2008, 64-69.
- Patel, Pinak S. et al., "Sensor Fault Detection in Wireless Sensor Networks and Avoiding the Path Failure Nodes", International Journal of Industrial Electronics and Electrical Engineering, vol. 2, Issue—3, Mar. 2014, 2347-6982.
- Patel, Shwetak N. et al., "The Design and Evaluation of an End-User-Deployable, Whole House, Contactless Power Consumption Sensor", CHI 2010: Domestic Life, Apr. 2010, 10 pages.
- Pato, Silvia et al., "On building a distributed antenna system with joint signal processing for next generation wireless access networks: The FUTON approach", 7th Conference on Telecommunications, Portugal, 2008, 4 pages.
- Paul, Sanjoy et al., "The Cache-and-Forward Network Architecture for Efficient Mobile Content Delivery Services in the Future Internet", Innovations in NGN: Future Network and Services, First ITU-T Kaleidoscope Academic Conference, 2008, 8 pages.
- PCT, "International Search Report", dated Oct. 25, 2016 1-12.
- Perkons, Alfred R. et al., "TM surface-wave power combining by a planar active-lens amplifier", IEEE Transactions on Microwave Theory and Techniques, 46.6, Jun. 1998, 775-783.
- Péter, Zsolt et al., "Assessment of the current intensity for preventing ice accretion on overhead conductors", Power Delivery, IEEE Transactions on 22.1: 4, 2007, 565-57.
- Petrovsky, Oleg , "The Internet of Things: A Security Overview", www.druva.com, Mar. 31, 2015 3 pages.
- Pham, Tien-Thang et al., "A WDM-PON-compatible system for simultaneous distribution of gigabit baseband and wireless ultrawideband services with flexible bandwidth allocation", Photonics Journal, IEEE 3.1, 2011, 13-19.
- Pike, Kevin J. et al., "A spectrometer designed for 6.7 and 14.1 T DNP-enhanced solid-state MAS NMR using quasi-optical microwave transmission", Journal of Magnetic Resonance, 2012, 9 pages.
- Piksa, Petr et al., "Elliptic and hyperbolic dielectric lens antennas in mmwaves", Radioengineering 20.1, 2011, 271.
- Pixel Technologies, "PRO 600 SIRIUS XM Radio Amplified Outdoor Antenna", Oct. 3, 2014, 1 page.
- Plagemann, Thomas et al., "Infrastructures for Community Networks", Content Delivery Networks. Springer Berlin Heidelberg, 2008, 367-388.
- Pohl, Nils , "A dielectric lens-based antenna concept for high-precision industrial radar measurements at 24GHz", Radar Conference (EuRAD), 2012 9th European, IEEE, 2012, 5 pages.
- Ponchak, George E. et al., "A New Model for Broadband Waveguide to Microstrip Transition Design", NASA TM-88905, Dec. 1, 1986, 18 pgs.
- Potlapally, Nachiketh R. et al., "Optimizing Public-Key Encryption for Wireless Clients", Proceedings of the IEEE International Conference on Communications, 2002, 1050-1056.
- Pranonsatit, S. et al., "Sectorised horn antenna array using an RF MEMS rotary switch", Asia-Pacific Microwave Conference, 2010, 1909-1913.
- Pranonsatit, Suneat et al., "Single-pole eight-throw RF MEMS rotary switch", Journal of Microelectromechanical Systems 15.6, 2006, 1735-1744.
- Prashant, R.R. et al., "Detecting and Identifying the Location of Multiple Spoofing Adversaries in Wireless Network", International Journal of Computer Science and Mobile Applications, vol. 2 Issue. 5, May 2014, 1-6.
- Qi, Xue et al., "Ad hoc QoS ondemand routing (AQOR) in mobile ad hoc networks", Journal of parallel and distributed computing 63.2, 2003, 154-165.
- Qiu, Lili et al., "Fault Detection, Isolation, and Diagnosis in Multihop Wireless Networks", Dec. 2003, 16 pages.
- Quan, Xulin , "Analysis and Design of a Compact Dual-Band Directional Antenna", IEEE Antennas and Wireless Propagation Letters, vol. 11, 2012, 547-550.
- Quinstar Technology, Inc. "Prime Focus Antenna (QRP series)", quinstar.com, Aug. 19, 2016 2 pages.
- Rahim, S. K. A. et al., "Measurement of wet antenna losses on 26 GHz terrestrial microwave link in Malaysia", Wireless Personal Communications 64.2, 2012, 225-231.
- Rambabu, K. et al., "Compact single-channel rotary joint using ridged waveguide sections for phase adjustment", IEEE Transactions on Microwave Theory and Techniques, 51(8):1982-1986, Abstract Only, Aug. 2003, 2 pages.
- Ranga, Yogesh et al., "An ultra-wideband quasi-planar antenna with enhanced gain", Progress in Electromagnetics Research C 49, 2014, 59-65.

(56)

References Cited

OTHER PUBLICATIONS

- Rangan, Sundeep et al., "Millimeter-Wave Cellular Wireless Networks: Potentials and Challenges", Proceedings of the IEEE, vol. 102, No. 3, Mar. 2014, 366-385.
- Rangel, Rodrigo K. et al., "Sistema de Inspecao de Linhas de Transmissao de Energia Electrica Utilizando Veiculos Aereos Nao-Tripulados", Sep. 14-16, 2009, 1-9.
- Rappaport, Theodore S. et al., "Mobile's Millimeter-Wave Makeover", Spectrum.IEEE.Org, Sep. 2014, 8 pages.
- Raychaudhuri, Dipankar et al., "Emerging Wireless Technologies and the Future Mobile Internet", Cambridge University Press, Abstract Only, Mar. 2011, 1 page.
- Rekimoto, Jun, "SmartSkin: An Infrastructure for Freehand Manipulation on Interactive Surfaces", <https://vs.inf.ethz.ch/edu/SS2005/DS/papers/surfaces/rekimoto-smartskin.pdf>, 2002, 8 pages.
- Ren-Bin, Zhong et al., "Surface plasmon wave propagation along single metal wire", Chin. Phys. B, vol. 21, No. 11, May 2, 2012, 9 pages.
- Reynet, Olivier et al., "Effect of the magnetic properties of the inclusions on the high-frequency dielectric response of diluted composites", Physical Review B66.9: 094412, 2002, 10 pages.
- RF Check, "Examples of Cell Antennas", <https://web.archive.org/web/20100201214318/http://www.rfcheck.com/Examplesof-Cell-Antennas.php>, Feb. 1, 2010, 1 page.
- Ricardi, L. J., "Some Characteristics of a Communication Satellite Multiple-Beam Antenna", Massachusetts Institute of Technology, Lincoln Laboratory, Technical Note 1975-3, Jan. 28, 1975, 62 pages.
- Rieke, M. et al., "High-Precision Positioning and Real-Time Data Processing of UAV Systems", International Archives of the Photogrammetry, Remote Sensing and Spatial Information Sciences, vol. XXXVIII-1/C22, 2011, 119-124.
- Robinson, D.A. et al., "Advancing processbased watershed hydrological research using nearsurface geophysics: A vision for, and review of, electrical and magnetic geophysical methods", Hydrological Processes 22.18, Mar. 11, 2008, 3604-3635.
- Robles, Rosslyn John et al., "A Review on Security in Smart Home Development", International Journal of Advanced Science and Technology 15, Feb. 2010, 13-22.
- Rosenberg, Uwe et al., "A novel frequency-selective power combiner/divider in single-layer substrate integrated waveguide technology", IEEE Microwave and Wireless Components Letters, vol. 23, No. 8, Aug. 2013, 406-408.
- Rouse, Margaret, "Transport Layer Security (TLS)", TechTarget, searchsecurity.techtarget.com, Jul. 2006, 4 pages.
- Rousstia, M. W., "Switched-beam antenna array design for millimeter-wave applications", <https://pure.tue.nl/ws/files/4418145/599448877400424.pdf>, Jan. 1, 2011, 148 pages.
- Roze, Mathieu et al., "Suspended core subwavelength fibers: towards practical designs for low-loss terahertz guidance", Optics express 19.10, 2011, 9127-9138.
- Sagar, Nishant, "Powerline Communications Systems: Overview and Analysis", Thesis, May 2011, 80 pages.
- Sagues, Mikel et al., "Multi-tap complex-coefficient incoherent microwave photonic filters based on optical single-sideband modulation and narrow band optical filtering", Optics express 16.1, 2008, 295-303.
- Sahoo, Srikanta, "Faulty Node Detection in Wireless Sensor Networks Using Cluster", Apr. 2013, 212-223.
- Saied, Yosra Ben et al., "Trust management system design for the internet of things: a contextaware and multiservice approach", Computers & Security 39: 351365, Abstract Only, 2013, 2 pages.
- Salema, Carlos et al., "Solid Dielectric Horn Antennas", Artech House Publishers, Amazon, Book—description only, 1998, 3 pages.
- Sarafi, Angeliki et al., "Hybrid wireless-broadband over power lines: A promising broadband solution in rural areas", Communications Magazine, IEEE 47.11, 2009, 140-147.
- Sarnecki, Joseph et al., "Microcell design principles", Communications Magazine, IEEE 31.4, 1993, 76-82.
- Saruhan, Ibrahim Halil, "Detecting and Preventing Rogue Devices on the Network", SANS Institute InfoSec Reading Room, sans.org, Aug. 8, 2007, 1 page.
- Scarfone, Karen et al., "Technical Guide to Information Security Testing and Assessment", National Institute of Standards and Technology, csrc.nist.gov, Special Publication, Sep. 2008, 800-115.
- Scerri, Paul et al., "Geolocation of RF emitters by many UAVs", AIAA Infotech, Aerospace 2007 Conference and Exhibit, 2007, 1-13.
- Schoning, Johannes et al., "Multi-Touch Surfaces: A Technical Guide", Johannes Schöning, Institute for Geoinformatics University of Münster, Technical Report TUM-I0833, 2008, 19 pages.
- Sciencedaily, "New Wi-Fi antenna enhances wireless coverage", www.sciencedaily.com, Apr. 29, 2015 2 pages.
- Security Matters, "Product Overview: Introducing SilentDefense", secmatters.com, Nov. 9, 2013, 1 page.
- Sembiring, Krisantus, "Dynamic Resource Allocation for Cloud-based Media Processing", <http://www.chinacloud.cn/upload/2013-04/13042109511919.pdf>, 2013, 49-54.
- Sengled, "Boost: The world's first WI-FI extending led bulb", www.sengled.com/sites/default/files/field/product/downloads/manual/a01-a60_na_user_manual.pdf, Dec. 2014, 32 pages.
- Shafai, Lotfollah, "Dielectric Loaded Antennas", John Wiley & Sons, Inc, www.researchgate.net/publication/227998803_Dielectric_Loaded_Antennas, Apr. 15, 2005, 82 pages.
- Shafi, Mansoor et al., "Advances in Propagation Modeling for Wireless Systems", EURASIP Journal on Wireless Communications and Networking, Hindawi Publishing Corp, 2009, p. 5.
- Shankland, Steven, "Lowly DSL poised for gigabit speed boost", www.cnet.com, Oct. 21, 2014, 5 pages.
- Sharma, Archana et al., "Dielectric Resonator Antenna for X band Microwave Application", Research & Reviews, International Journal of Advanced Research in Electrical, Electronics and Instrumentation Engineering, Oct. 2016 9 pages.
- Shekar, Chandra P., "Transmission Line Fault Detection & Indication through GSM", IRD India, ISSN (Online): 2347-2812, vol. 2, Issue 5, 2014, 28-30.
- Shila, Devu M., "Load-Aware Traffic Engineering for Mesh Networks", Computer Communications 31.7, 2008, 1460-1469.
- Shimabukuko, F.I. et al., "Attenuation measurement of very low-loss dielectric waveguides by the cavity resonator method in the millimeter/submillimeter wavelength range", No. TR-0086A (2925-06)-1, Aerospace Corp El Segundo CA Electronics Research Lab, Mar. 20, 1989, 35 pages.
- Shindo, Shuichi et al., "Attenuation measurement of cylindrical dielectric-rod waveguide", Electronics Letters 12.5, 1976, 117-118.
- Shumate, Paul W. et al., "Evolution of fiber in the residential loop plant", IEEE Communications Magazine 29.3, 1991, 68-74.
- Sievenpiper, D.F. et al., "Two-dimensional beam steering using an electrically tunable impedance surface", IEEE Transactions on Antennas and Propagation, vol. 51, No. 10, Nov. 2003, pp. 2713-2722.
- Silver, Ralph U., "Local Loop Overview", National Communications System (NCS), BellSouth Network Training, newnetworks.com, Aug. 2016 100 pages.
- Silvonen, Kimmo, "Calibration and DeEmbedding of Microwave Measurements Using Any Combination of Oneor TwoPort Standards", Publication of the Circuit Theory Laboratory, CT4, 1987, 1-28.
- Simionovi, Ana-Maria et al., "Predictive Modeling in a VoIP System", 2013, 32-40.
- Simons, Rainee N., "Coplanar Waveguide Feeds for Phased Array Antennas", Solid State Technology Branch of NASA Lewis Research Center Fourth Annual Digest, Conference on Advanced Space Exploration Initiative Technologies cosponsored by AIAA, NASA and OAI, 1992, 1-9.
- Singh, Seema M. et al., "Broadband Over Power Lines A White Paper", State of New Jersey, Division of the Ratepayer Advocate, NJ, Oct. 2016 67 pages.
- Sommerfeld, A., "On the propagation of electrodynamic waves along a wire", Annals of Physics and Chemistry New Edition, vol. 67, No. 2, 1899, 72 pages.

(56)

References Cited

OTHER PUBLICATIONS

- Song, Kaijun et al., "Broadband radial waveguide power amplifier using a spatial power combining technique", www.mtech.edu/academics/mines/geophysical/xzhou/publications/songfanzhou_2009b_impa.pdf, 2009, 7 pages.
- Sospedra, Joaquim et al., "Badalona Oil PierBased Met-Ocean Monitoring Station", Campbell Scientific, www.campbellsci.com, Nov. 2016 2 pages.
- Souryal, Michael R. et al., "Rapidly Deployable Mesh Network Testbed", <https://pdfs.semanticscholar.org/f914/1ce6999c4095eab3bdea645745761ebe5141.pdf>, 2009, 6 pages.
- Spencer, D. G. , "Novel Millimeter ACC Antenna Feed", IEEE Colloquium on Antennas for Automotives, Mar. 10, 2000, 10 pages.
- Stancil, Daniel D. et al., "High-speed internet access via HVAC ducts: a new approach", Global Telecommunications Conference, IEEE vol. 6, 2001, 4 pages.
- Steatite, , "Custom Horn Antennas", Steatite QPar Antennas, steatiteqparantennas.co.uk, May 21, 2015 1 page.
- Strahler, Olivier , "Network Based VPNs", SANS Institute InfoSec Reading Room, www.sans.org, Aug. 2002, 18 pages.
- Strieby, M.E. et al., "Television transmission over wire lines", American Institute of Electrical Engineers, Transactions of the 60.12: 1090-1096, Abstract Only, 1941, 2 pages.
- "How to Use STUF", STUF Page Link Info, www.crossdevices.com, http://www.crossdevices.com/cross_devices_010.htm, 2015 1 page.
- Sun, Zhi et al., "Magnetic Induction Communications for Wireless Underground Sensor Networks", IEEE Transactions on Antennas and Propagation, vol. 58, No. 7, Jul. 2010, 2426-2435.
- Sundqvist, Lassi , "Cellular Controlled Drone Experiment: Evaluation of Network Requirements", 2015 71 pages.
- Szabó, Csaba A. , "European Broadband Initiatives with Public Participation", Broadband Services: 255, 2005, 305 pages.
- Szczys, Mike , "Cameras Perch on Power Lines, Steal Electricity", <http://hackaday.com/2010/06/28/cameras-perch-on-power-lines-steal-electricity/>, Discloses cameras that clamp on to power lines and use induction as a power source., 2010, 1 page.
- Taboada, John M. et al., "Thermo-optically tuned cascaded polymer waveguide taps", Applied physics letters 75.2, 1999, 163-165.
- Talbot, David , "Adapting Old-Style Phone Wires for Superfast Internet", Jul. 30, 2013, 3 pages.
- Tantawi, Sami G. et al., "High-power multimode X-band rf pulse compression system for future linear colliders", Physical Review Special Topics—Accelerators and Beams, 1098-4402/05/8(4)/042002, 2005, 19 pages.
- Tech Briefs Media Group, , "Tapered Waveguides Improve Fiber Light Coupling Efficiency", www.techbriefs.com, Jan. 1, 2006, 2 pages.
- Templeton, Steven J. et al., "Detecting Spoofed Packets", DARPA Information Survivability Conference and Exposition, vol. 1, IEEE, 2003, 12 page.
- Teng, Ervin et al., "Aerial Sensing and Characterization of ThreeDimensional RF Fields", Univ. at Buffalo, cse.buffalo.edu, Sep. 2016 6 pages.
- Tesoriero, Ricardo et al., "Tracking autonomous entities using RFID technology", IEEE Transactions on Consumer Electronics 55.2, 2009, 650-655.
- Theoleyr, Fabrice , "Internet of Things and M2M Communications", books.google.com, ISBN13: 9788792982483, Book—description only, Apr. 17, 2013, 1 page.
- Thornton, John et al., "Modern lens antennas for communications engineering", vol. 39, 2013, 48 pages.
- Thota, Saigopal et al., "Computing for Rural Empowerment: Enabled by Last-Mile Telecommunications (Extended Version)", Technical Report, 2013, 14 pages.
- Thottapan, M. , "Design and simulation of metal PBG waveguide mode launcher", www.researchgate.net/profile/Dr_M_Thottapan/publication/262415753_Design_and_Simulation_of_Metal_PBG_Waveguide_Mode_Launcher/links/0f317537ad93a5e2a4000000.pdf, 2014, 383-387.
- Tillack, M. S. et al., "Configuration and engineering design of the ARIES-RS tokamak power plant", https://www.researchgate.net/publication/222496003_Configuration_and_engineering_design_of_the_ARIES-RS_tokamak_power_plant, 1997, 87-113.
- Tucson Electric Power, , "Energy-Harvesting Power Supply", <http://sdpm.arizona.edu/projects/project-publi/upid/38a8cf3b42f35576de25de1f6dcc20f3>, Discloses a project to harvest energy from a power line and that a device was built that clamps onto a power line., 2016 1 page.
- Tyco Electronics, "RAYCHEM: Wire and Cable", Dimensions 2:1, 1996, 58 pages.
- UK Essays, , "Beam Adaptive Algorithms for Smart Antennas Computer Science Essay", www.ukessays.com, Mar. 23, 2015 21 pages.
- Valladares, Cindy , "20 Critical Security Controls: Control 7—Wireless Device Control", Tripwire—The State of Security, www.tripwire.com, Mar. 21, 2013, 10 pages.
- Van Atta, L.C. , "Contributions to the antenna field during World War II", www.nonstopsystems.com/radio/pdf-hell/article-IRE-5-1962.pdf, 1962, 692-697.
- Vogelgesang, Ralf et al., "Plasmonic nanostructures in aperture-less scanning near-field optical microscopy (aSNOM)", *physica status solidi (b)* 245.10, 2008, 2255-2260.
- Volat, C. et al., "De-icing/anti-icing techniques for power lines: current methods and future direction", Proceedings of the 11th International Workshop on Atmospheric Icing of Structures, Montreal, Canada, Jun. 2005, 11 pages.
- Wade, Paul , "Multiple Reflector Dish Antennas", www.w1ghz.org/antbook/conf/Multiple_reflector_antennas.pdf, 2004, 45 pages.
- Wagter, Herman , "Fiber-to-the-X: the economics of last-mile fiber", ARS Technica, www.arstechnica.com, Mar. 31, 2010, 3 pages.
- Wake, David et al., "Radio over fiber link design for next generation wireless systems", *Journal of Lightwave Technology* 28.16, 2010, 2456-2464.
- Wang, Hao et al., "Dielectric Loaded Substrate Integrated Waveguide (SIW)—Plan Horn Antennas", IEEE Transactions on Antennas and Propagation, IEEE Service Center, Piscataway, NJ, US, vol. 56, No. 3, Mar. 1, 2010, 640-647.
- Wang, Jing et al., "The influence of optical fiber bundle parameters on the transmission of laser speckle patterns", *Optics express* 22.8, 2014, 8908-8918.
- Wang, Wei , "Optimization Design of an Inductive Energy Harvesting Device for Wireless Power Supply System Overhead High-Voltage Power Lines", <https://pdfs.semanticscholar.org/3941/601af7a21d55e8b57ab0c50d5f1d9f9f6868.pdf>, Discloses an induction based energy harvesting device that takes energy from overhead powerlines (Figure 4), 2016 16 pages.
- Wang, Xingfu et al., "Zigzag coverage scheme algorithm & analysis for wireless sensor networks", *Network Protocols and Algorithms* 5.4, 2013, 19-38.
- Washiro, Takanori , "Applications of RFID over power line for Smart Grid", Power Line Communications and Its Applications (ISPLC), 2012 16th IEEE International Symposium on. IEEE, 2012, 83-87.
- Wenger, N. , "The launching of surface waves on an axial-cylindrical reactive surface", IEEE Transactions on Antennas and Propagation 13.1, 1965, 126-134.
- Werner, Louis B. et al., "Operation Greenhouse", Scientific Director's Report of Atomic Weapon Tests at Eniwetok, Annex 6.7 Contamination-Decontamination Studies Naval Radiological Defense Lab, 1951, 209 pages.
- Wikipedia, "Angular Momentum of Light", https://en.wikipedia.org/wiki/Angular_momentum_of_light, Nov. 10, 2016, 1-7.
- Wilkes, Gilbert , "Wave Length Lenses", Dec. 5, 1946, 49 pages.
- Wilkins, George A. , "Fiber Optic Telemetry in Ocean Cable Systems", Chapter in new edition of Handbook of Oceanographic Winch, Wire and Cable Technology, Alan H. Driscoll, Ed, 1986, 50 pages.
- Wolfe, Victor et al., "Feasibility Study of Utilizing 4G LTE Signals in Combination With Unmanned Aerial Vehicles for the Purpose of Search and Rescue of Avalanche Victims (Increment 1)", University of Colorado at Boulder, Research Report, 2014, 26 pages.

(56)

References Cited

OTHER PUBLICATIONS

Wolff, Christian , "Phased Array Antenna", Radar Tutorial, web.archive.org, radartutorial.eu, Oct. 21, 2014, 2 pages.

Won Jung, Chang et al., "Reconfigurable Scan-Beam Single-Arm Spiral Antenna Integrated With RF-MEMS Switches", IEEE Transactions on Antennas and Propagation, vol. 54, No. 2, Feb. 2006, 455-463.

Woodford, Chris , "How do touchscreens work?", www.explainthatstuff.com/touchscreens.html, Aug. 23, 2016 8 pages.

Wu, Xidong et al., "Design and characterization of singleand multiplebeam mmwave circularly polarized substrate lens antennas for wireless communications", Microwave Theory and Techniques, IEEE Transactions on 49.3, 2001, 431-441.

Xi, Liu Xiao , "Security services in SoftLayer", Sep. 21, 2015 18 pages.

Xia, Cen et al., "Supermodes for optical transmission", Optics express 19.17, 2011, 16653-16664.

Xiao, Shiyi et al., "Spin-dependent optics with metasurfaces", Nanophotonics 6.1, 215-234., 2016 215-234.

Yang, et al., "Power line sensornet—a new concept for power grid monitoring", IEEE Power Engineering Society General Meeting, Abstract Only, 2006, pp. 8.

Yang, Yi , "Power Line Sensor Networks for Enhancing Power Line Reliability and Utilization", Georgia Institute of Technology, https://smartech.gatech.edu/bitstream/handle/1853/41087/Yang_Yi_201108_phd.pdf, Apr. 26, 2011, 264 pages.

Yeh, C. et al., "Ceramic Waveguides", Interplanetary Network Progress Report 141.26: 1, May 15, 2000, 21 pages.

Yeh, C. et al., "Thin-Ribbon Tapered Coupler for Dielectric Waveguides", 5/151994, 42-48.

Yilmaz, et al., "Self-optimization of coverage and capacity in LTE using adaptive antenna systems", Aalto University, Feb. 2010, 72 pages.

Yousuf, Muhammad Salman , "Power line communications: An Overview Part I", King Fahd University of Petroleum and Minerals, Dhahran, KSA, 2008, 5 pages.

Yu, Shui et al., "Predicted packet padding for anonymous web browsing against traffic analysis attacks", Information Forensics and Security, IEEE Transactions on 7.4, <http://nsp.org.au/syu/papers/tifs12.pdf>, 2012, 1381-1393.

Zelby, Leon W. , "Propagation Modes on a Dielectric Coated Wire", Journal of the Franklin Institute, vol. 274(2), Aug. 1962, pp. 85-97.

Zhang, , "Modified Tapered Slot-line Antennas for Special Applications", REV Journal on Electronics and Communications, vol. 2, Jul.-Dec. 2012, 106-112.

Zhang, Ming et al., "PlanetSeer: Internet Path Failure Monitoring and Characterization in Wide Area Services", OSDI, vol. 4, 2004, 33 pages.

Zhao, et al., "Energy harvesting for a wireless-monitoring system of overhead high-voltage power lines", IET Generation, Transmission & Distribution 7, IEEE Xplore Abstract, 2013, 2 pages.

Zheng, Zhu et al., "Efficient coupling of propagating broadband terahertz radial beams to metal wires", Optics express 21.9, 2013, 10642-10650.

Zucker, Francis J. , "Surface-Wave Antennas", Antenna Engineering Handbook, Chapter 10, 2007, 32 pages.

* cited by examiner

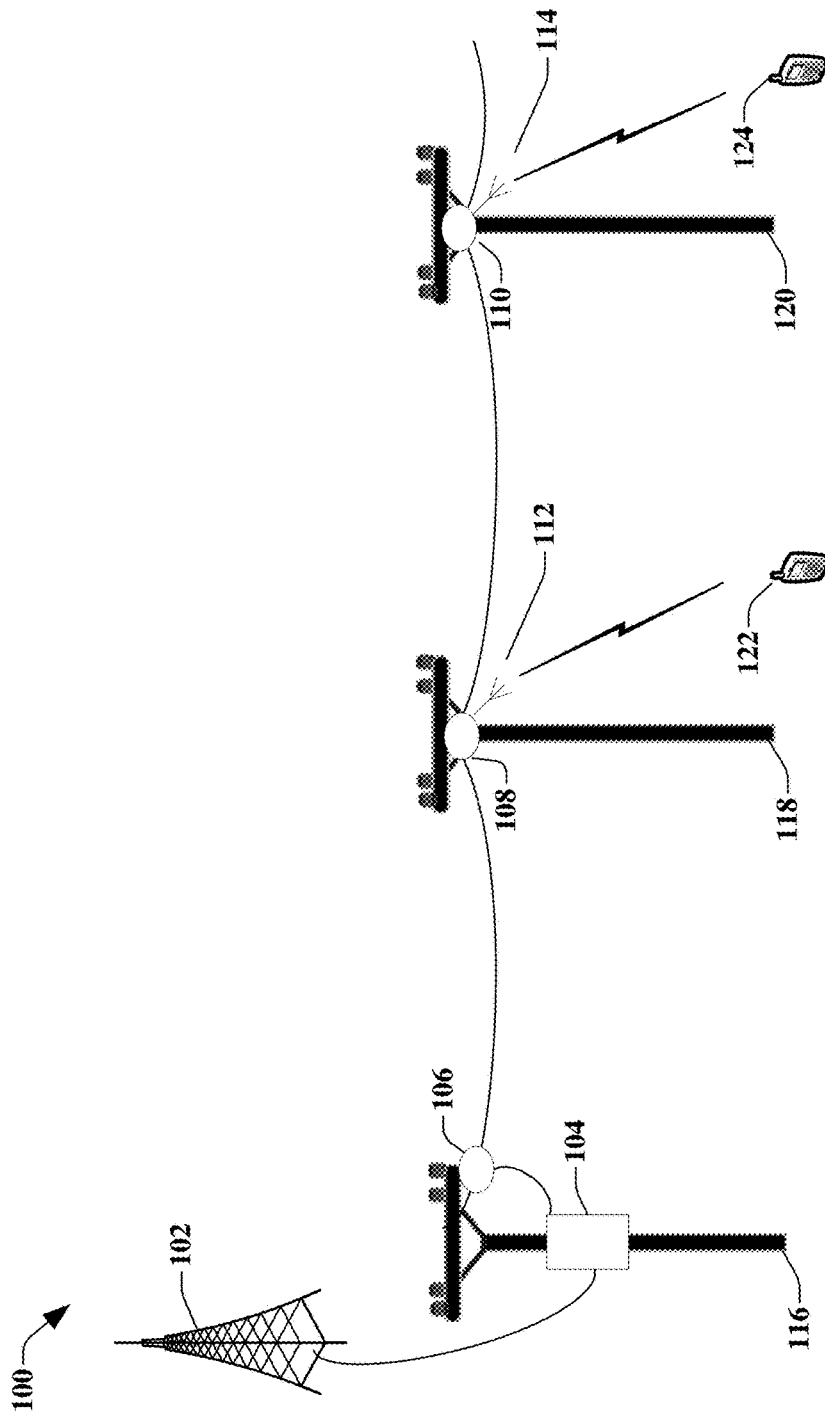

FIG. 1

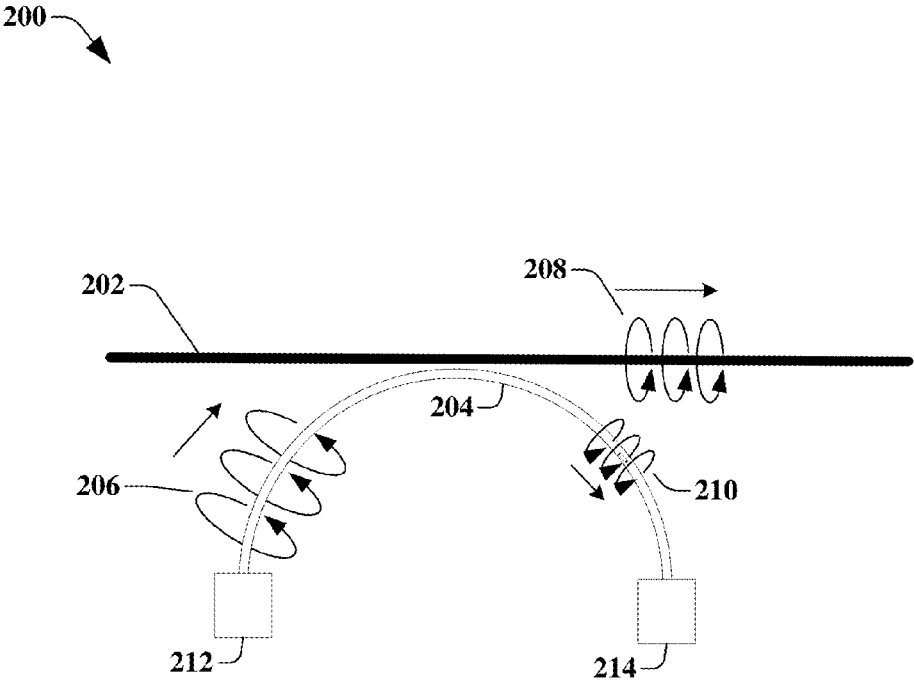

FIG. 2

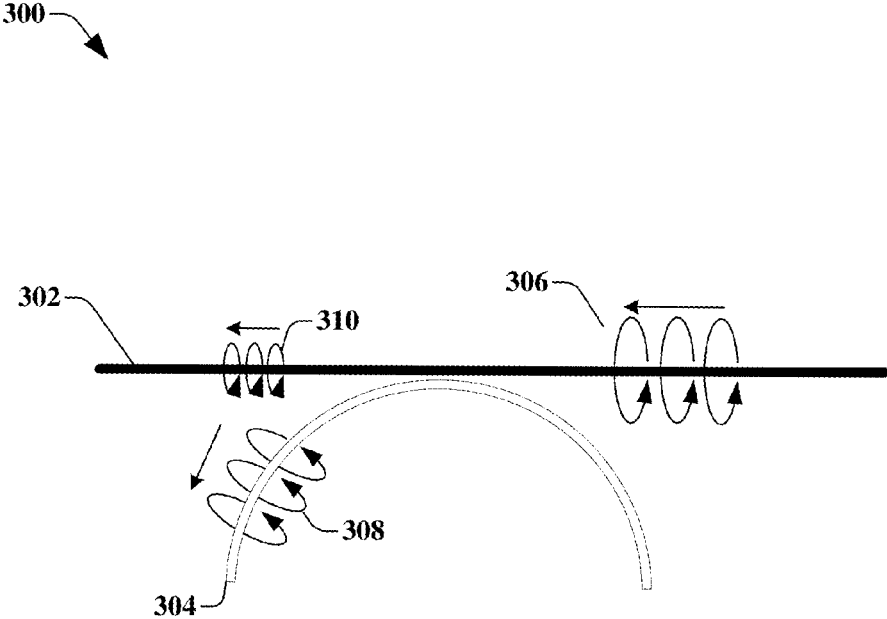

FIG. 3

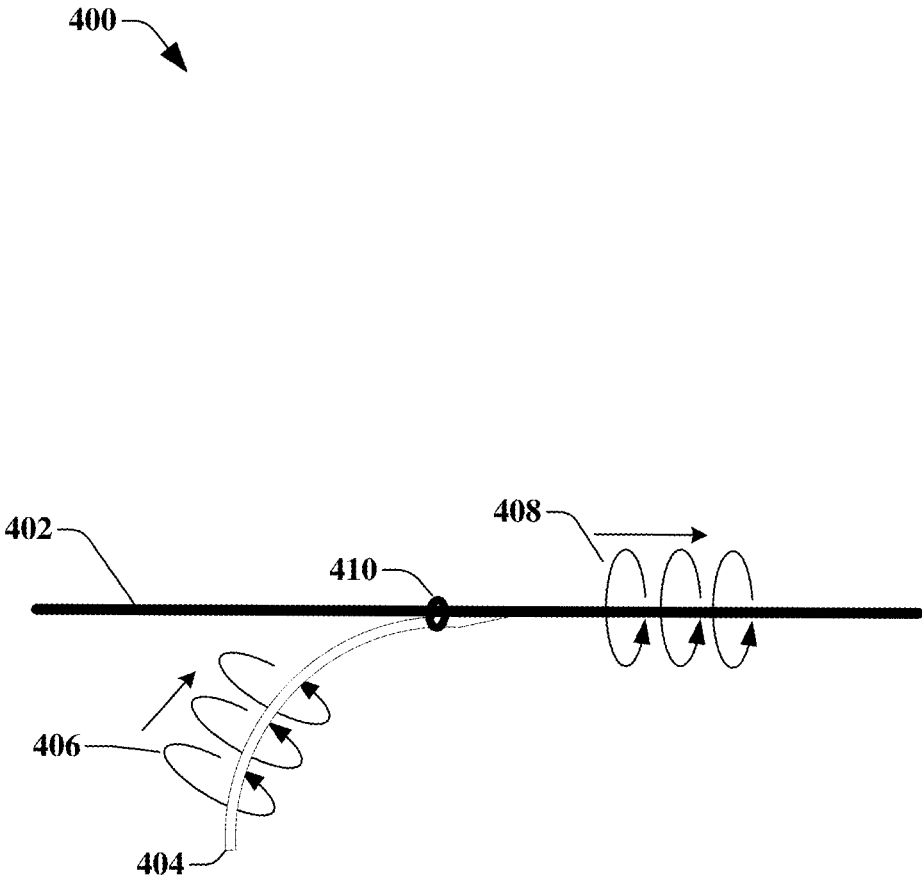

FIG. 4

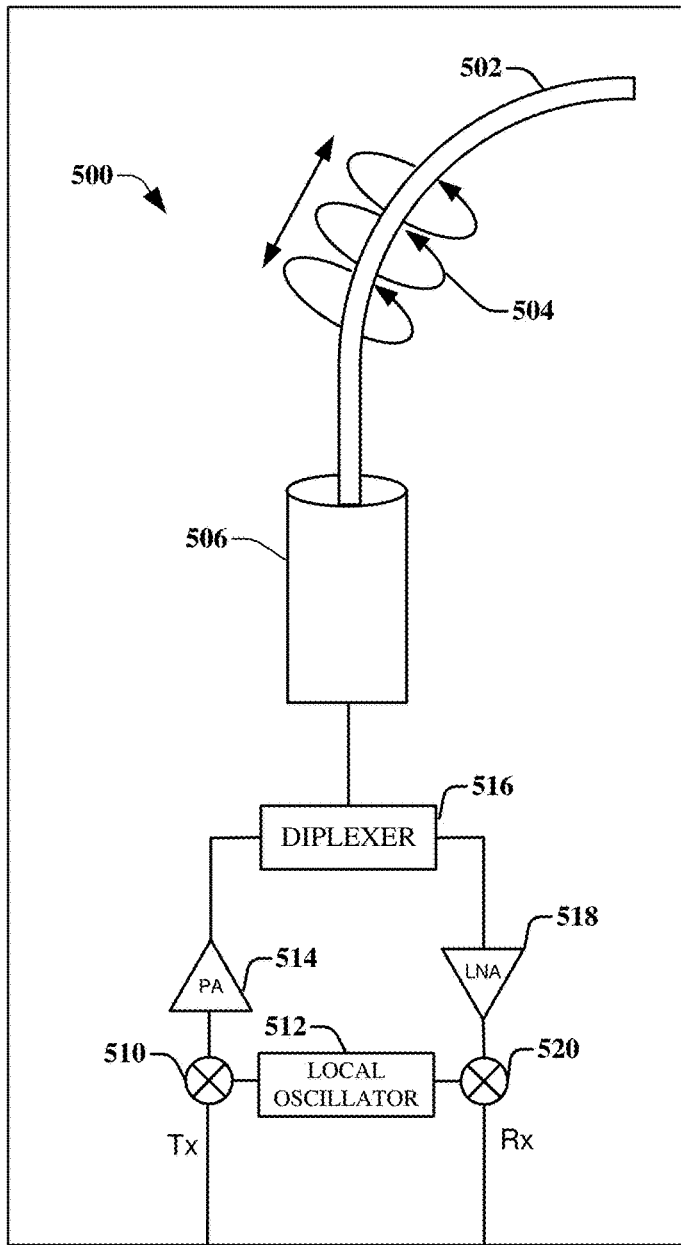
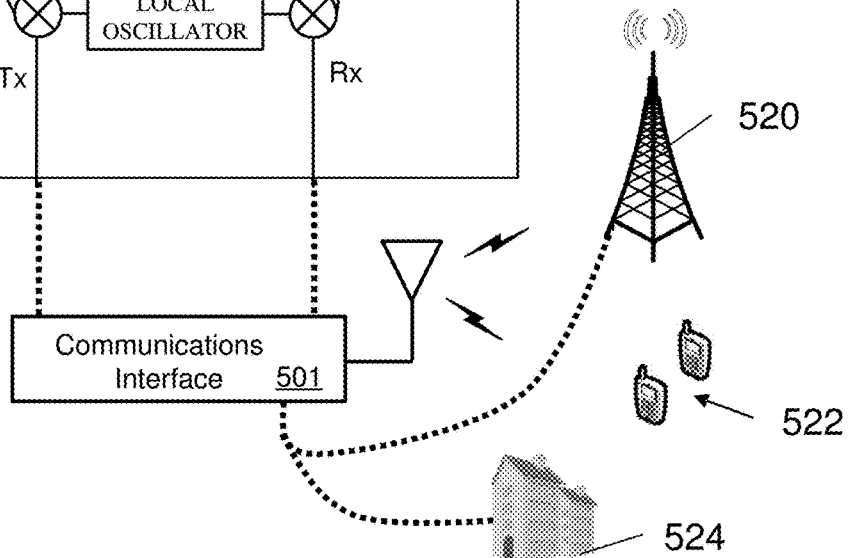

FIG. 5



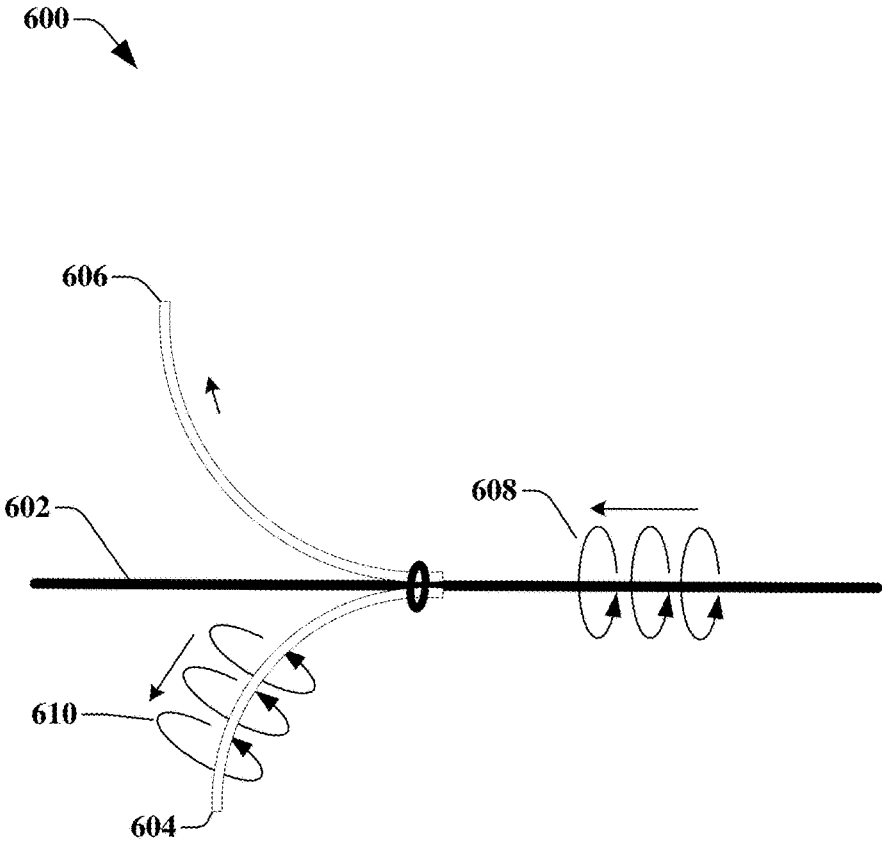

FIG. 6

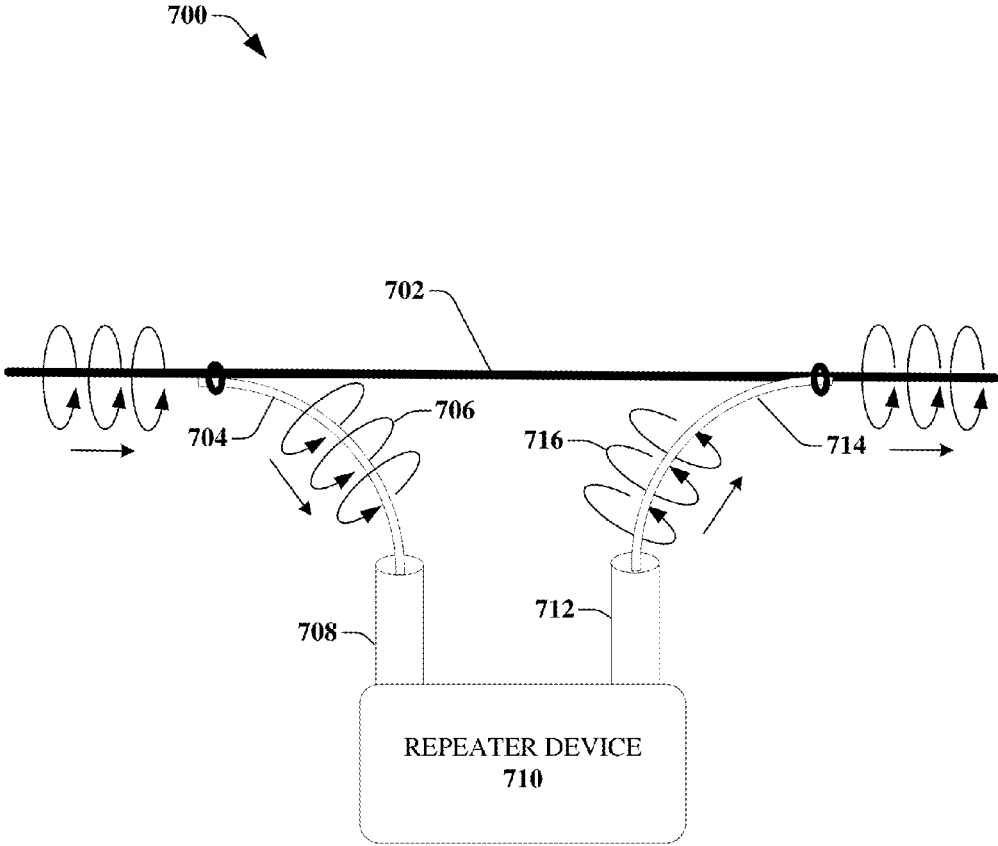

FIG. 7

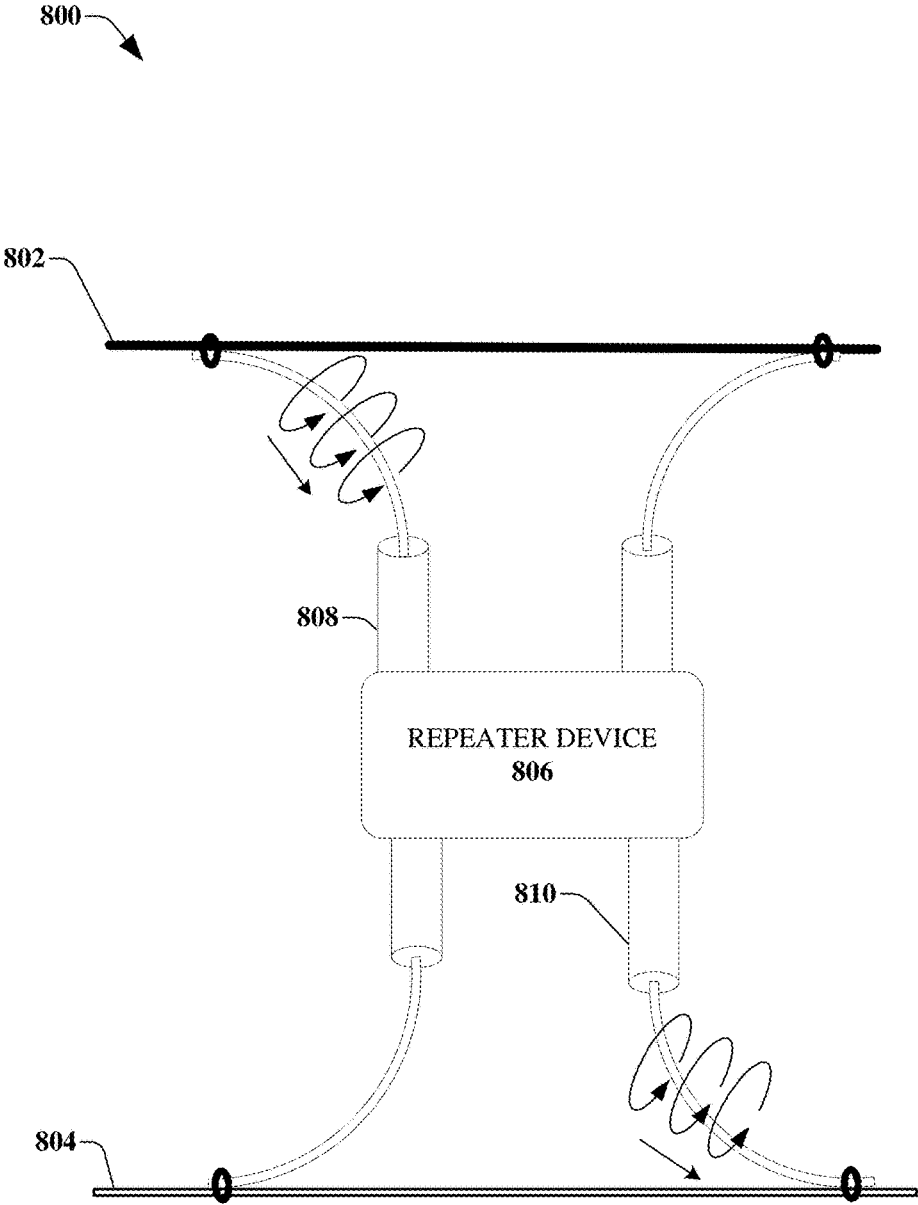

FIG. 8

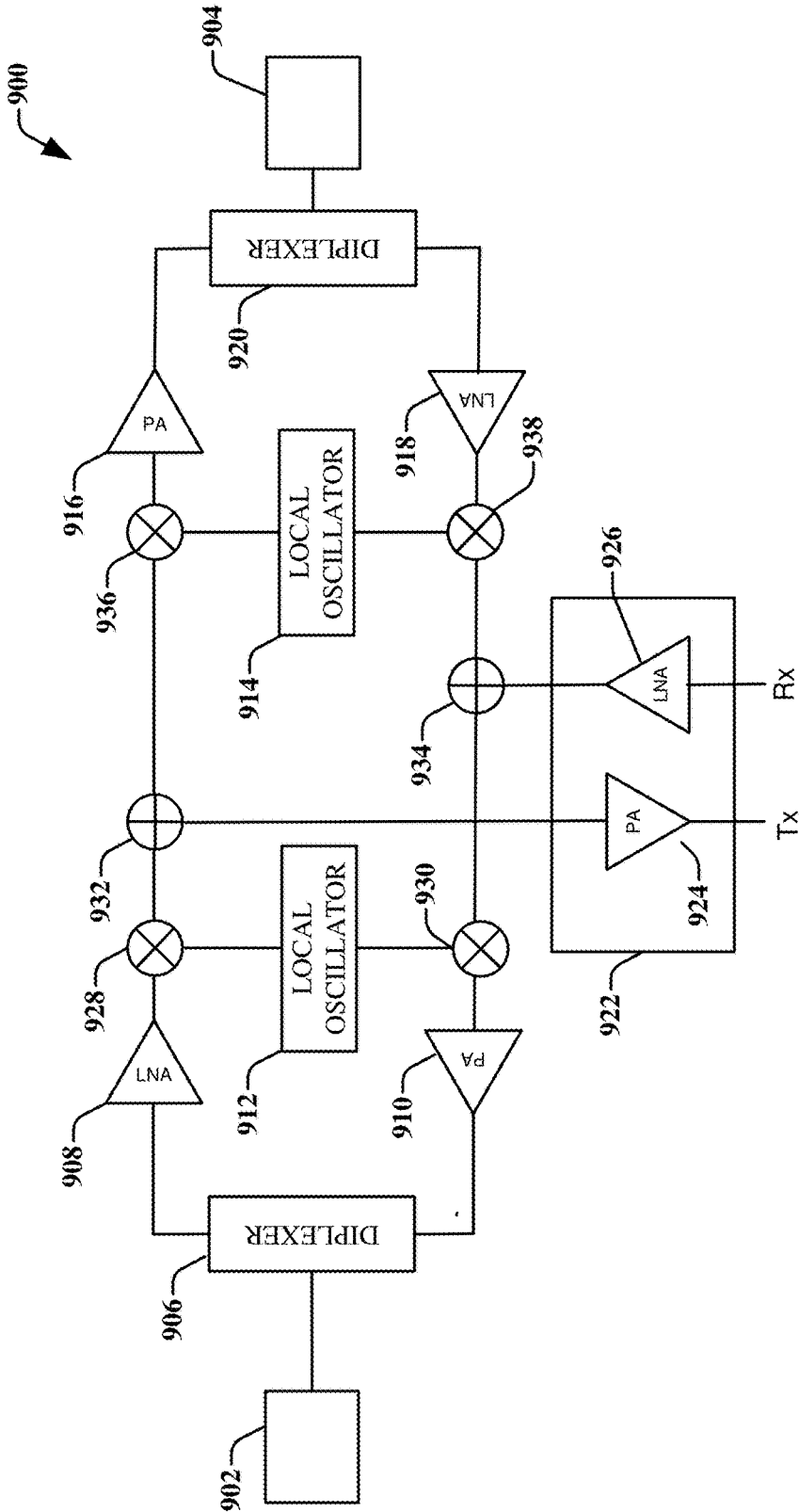

FIG. 9

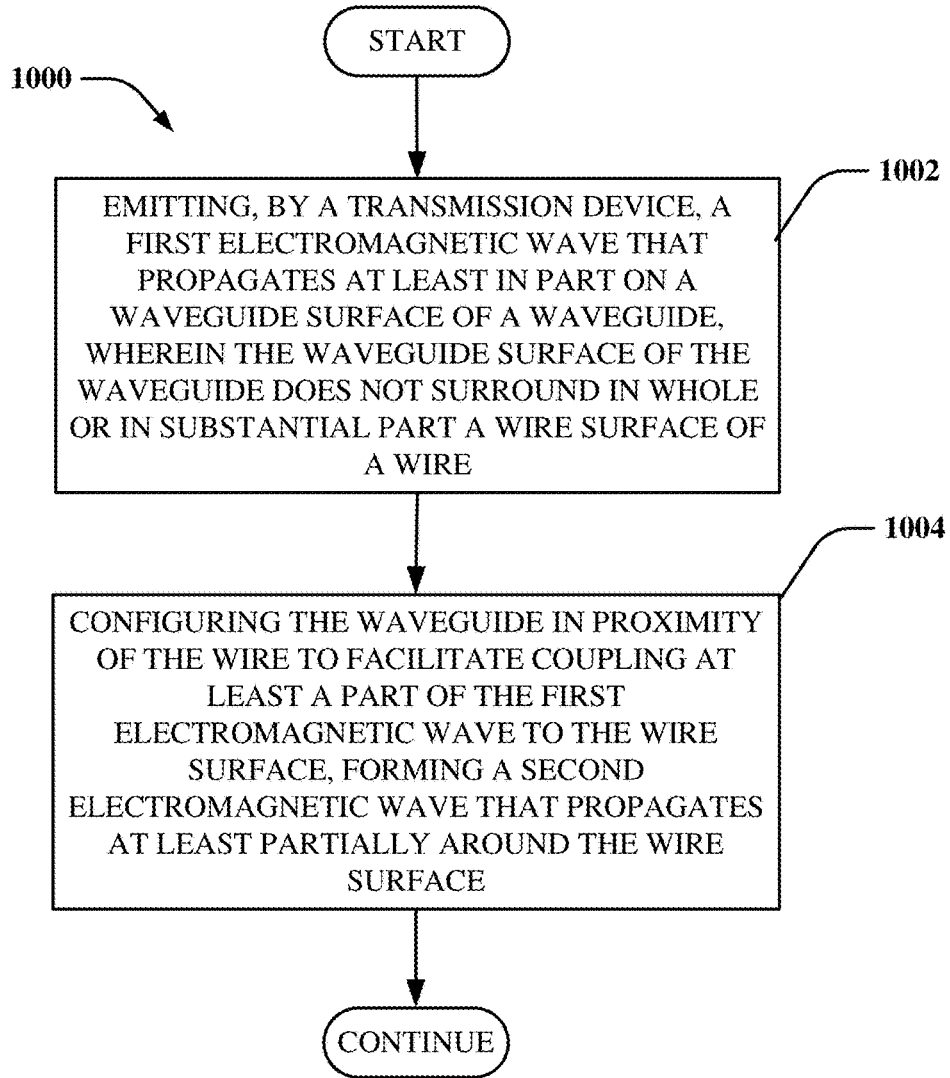

FIG. 10

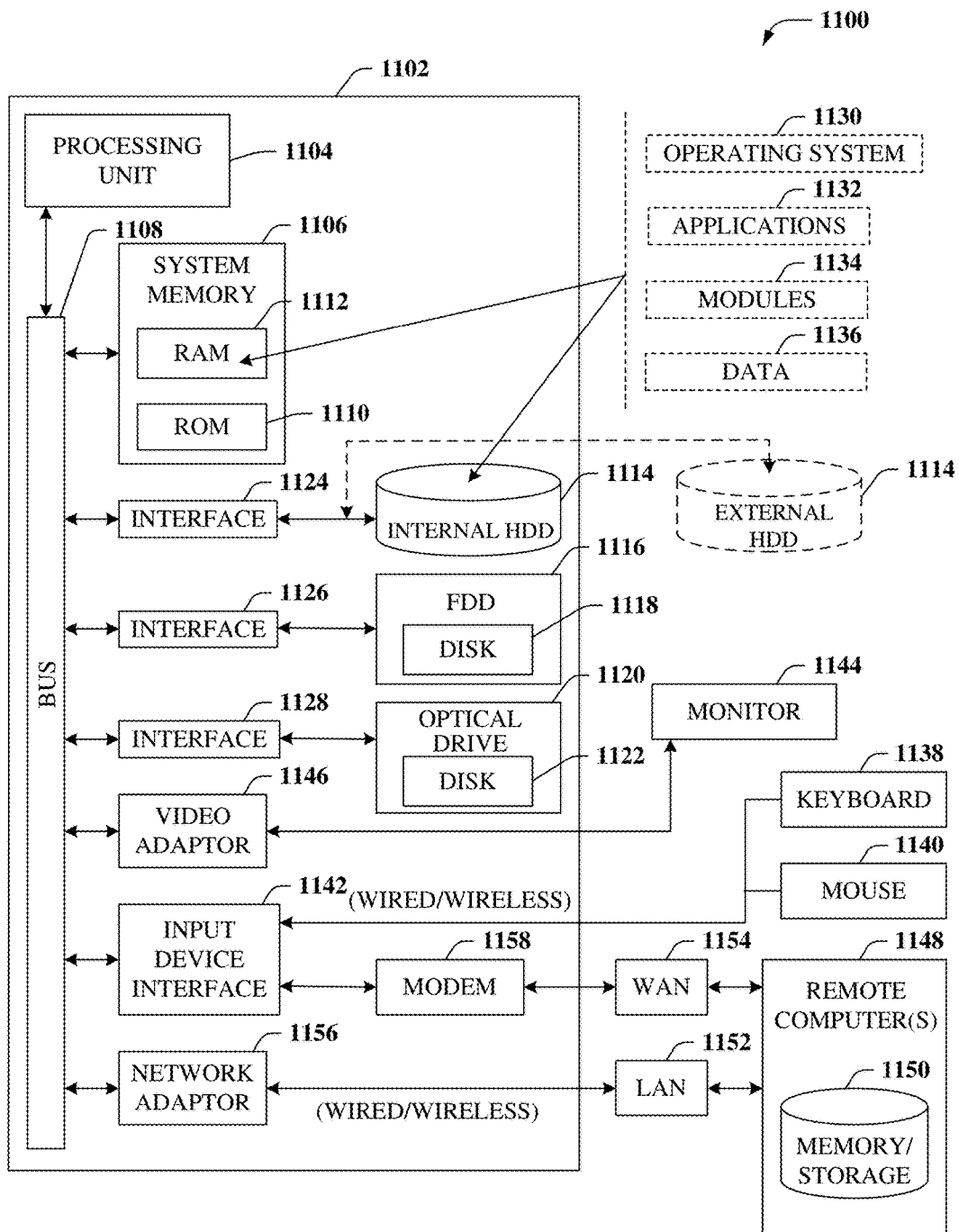

FIG. 11

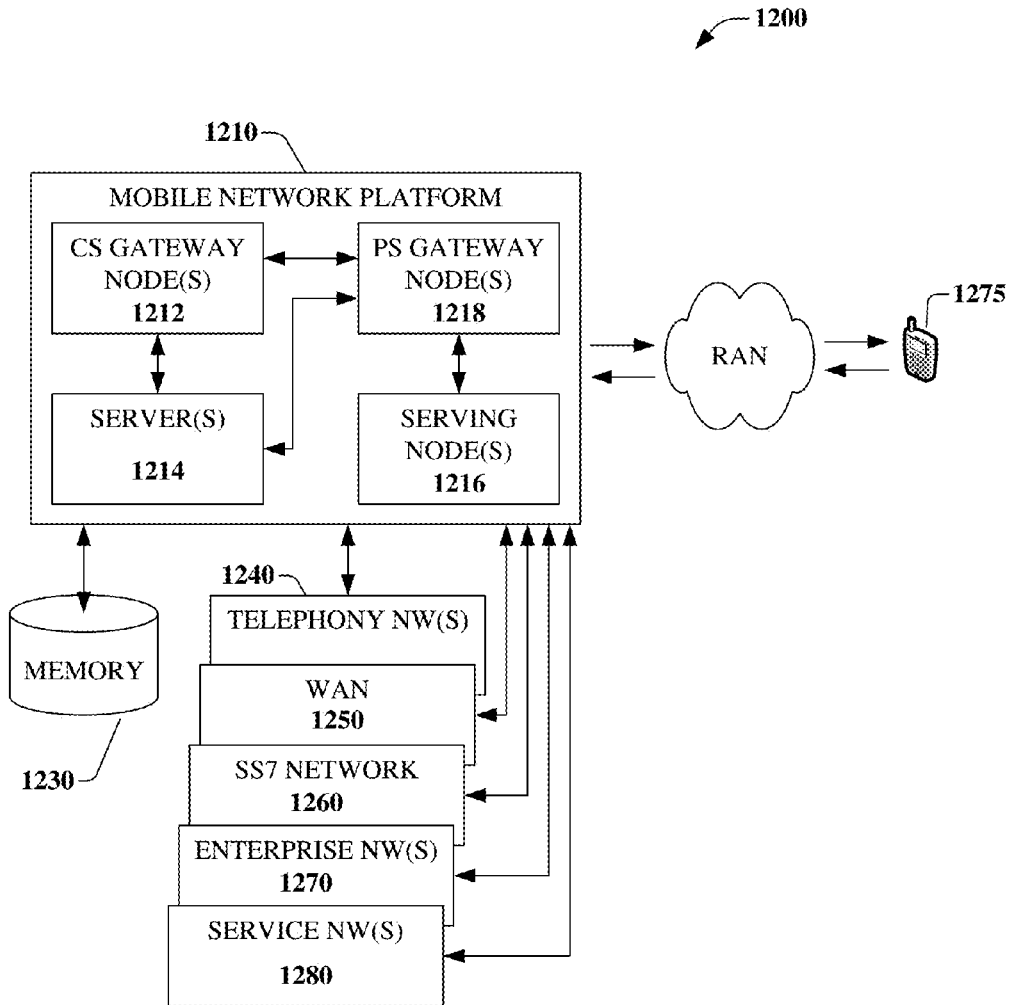

FIG. 12

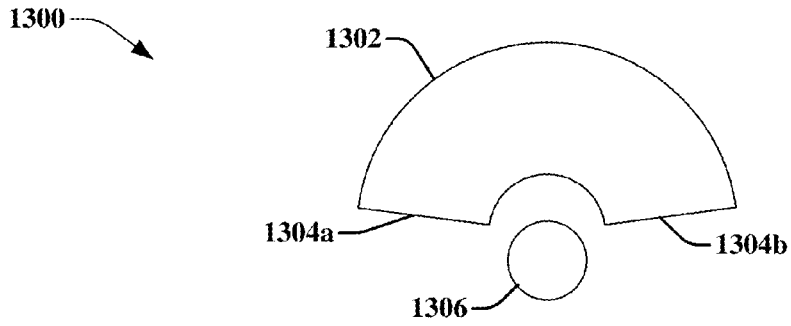

FIG. 13a

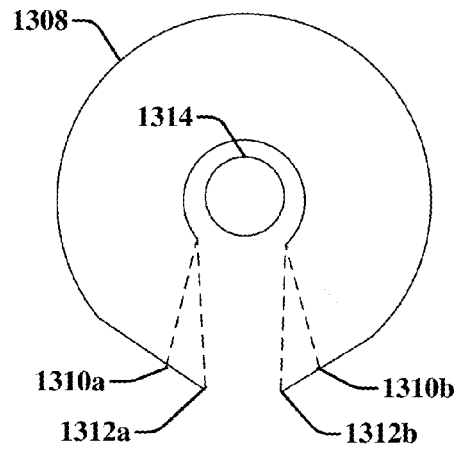

FIG. 13b

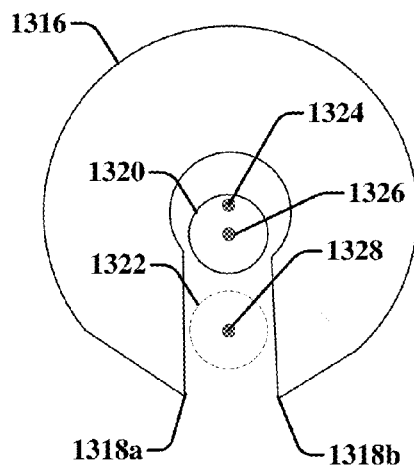

FIG. 13c

1400

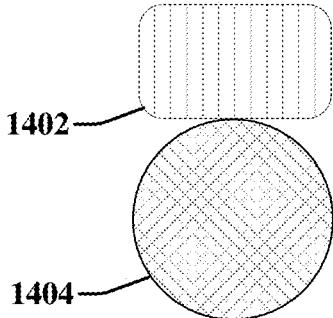

FIG. 14a

1410

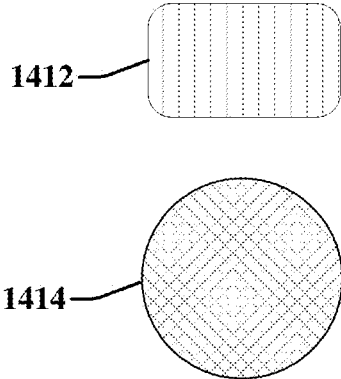

FIG. 14b

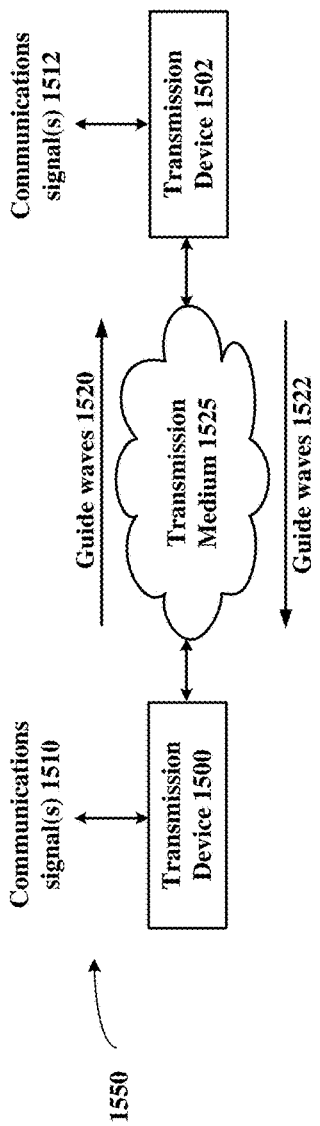

FIG. 15

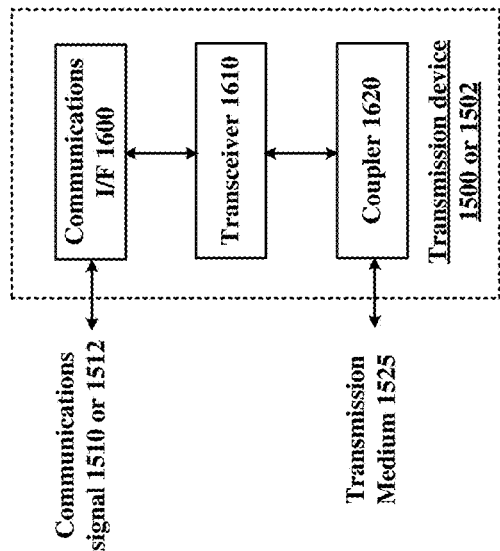

FIG. 16

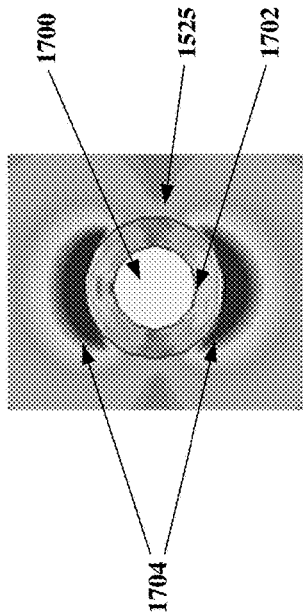

FIG. 17

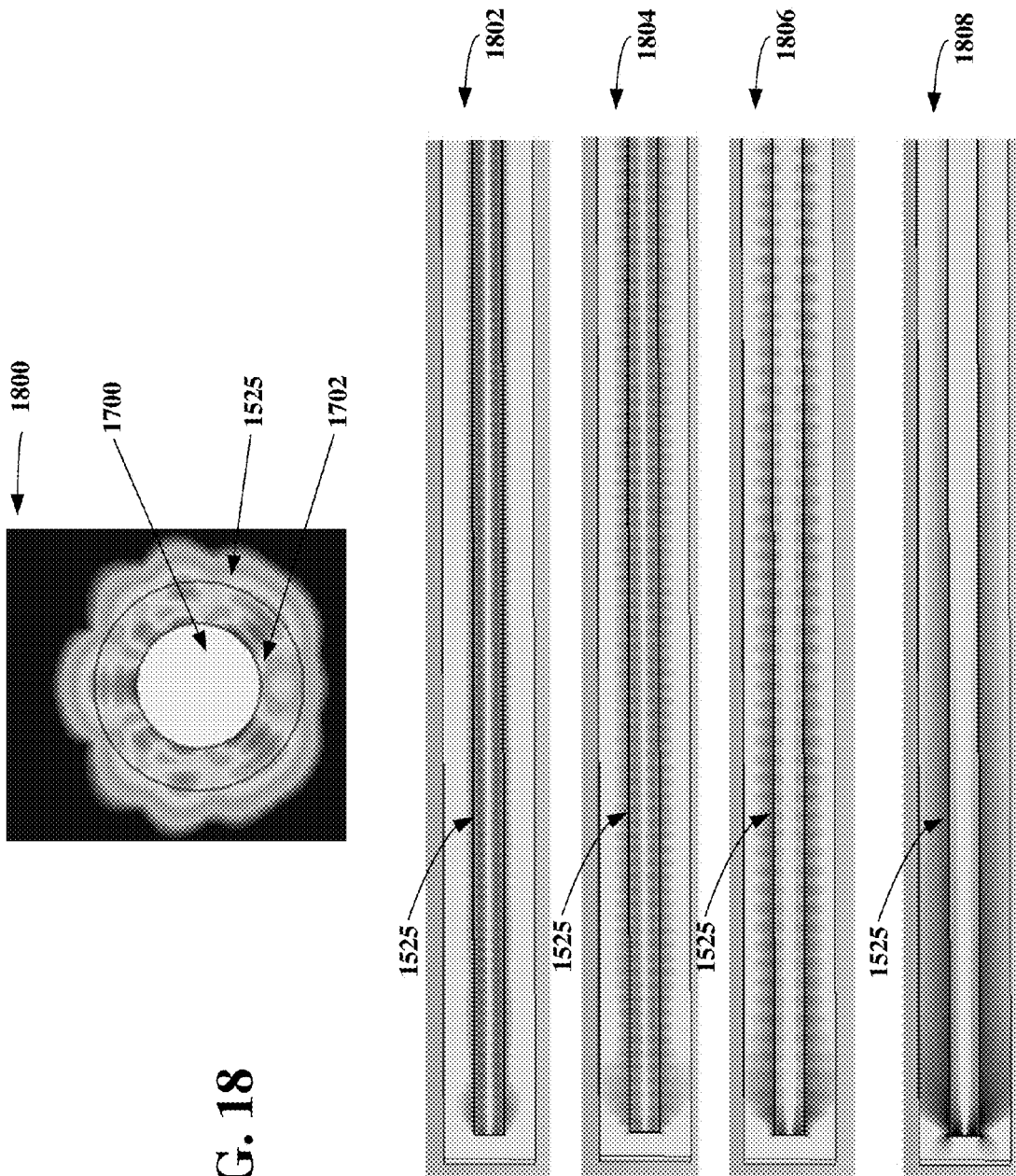

FIG. 18

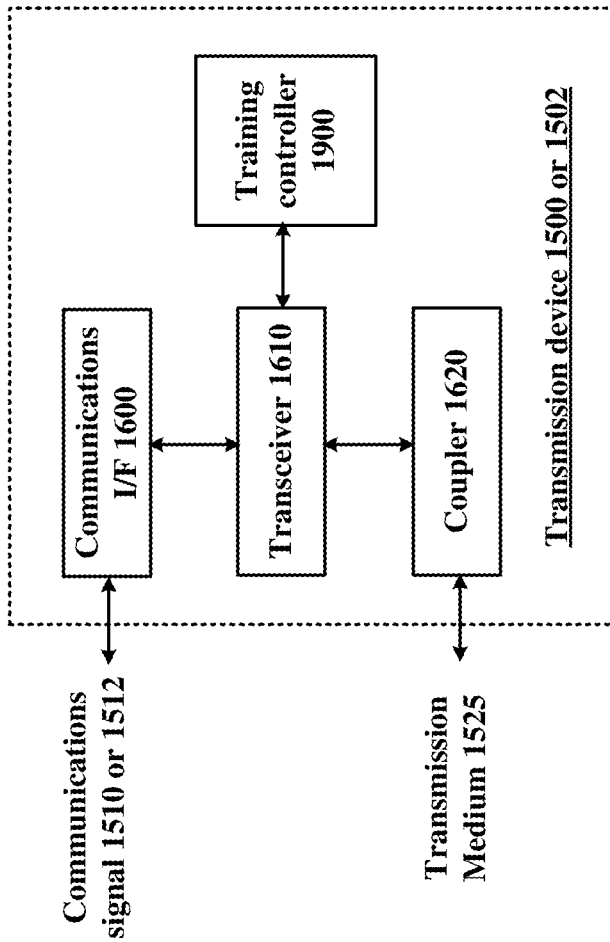

FIG. 19

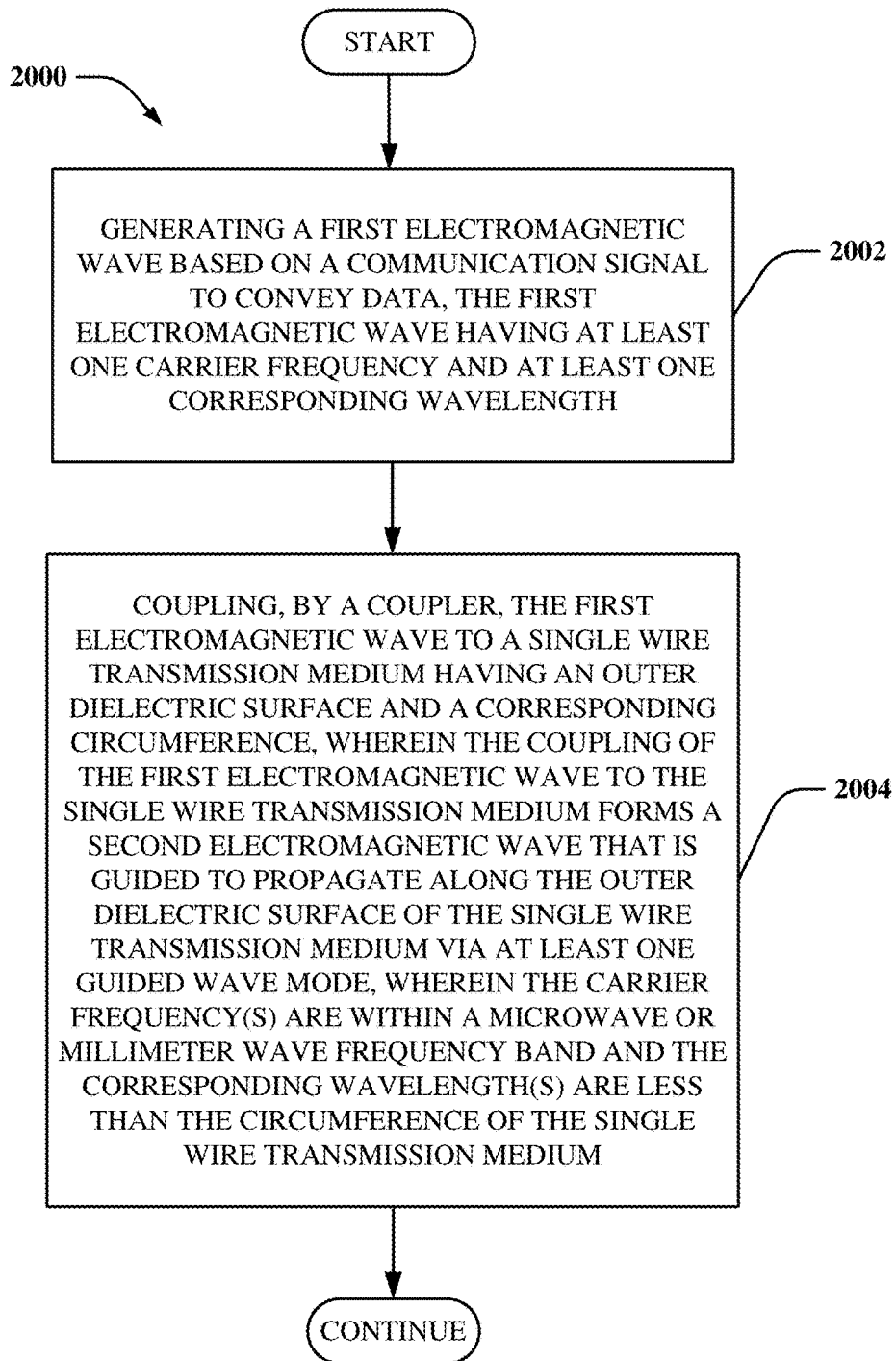

FIG. 20

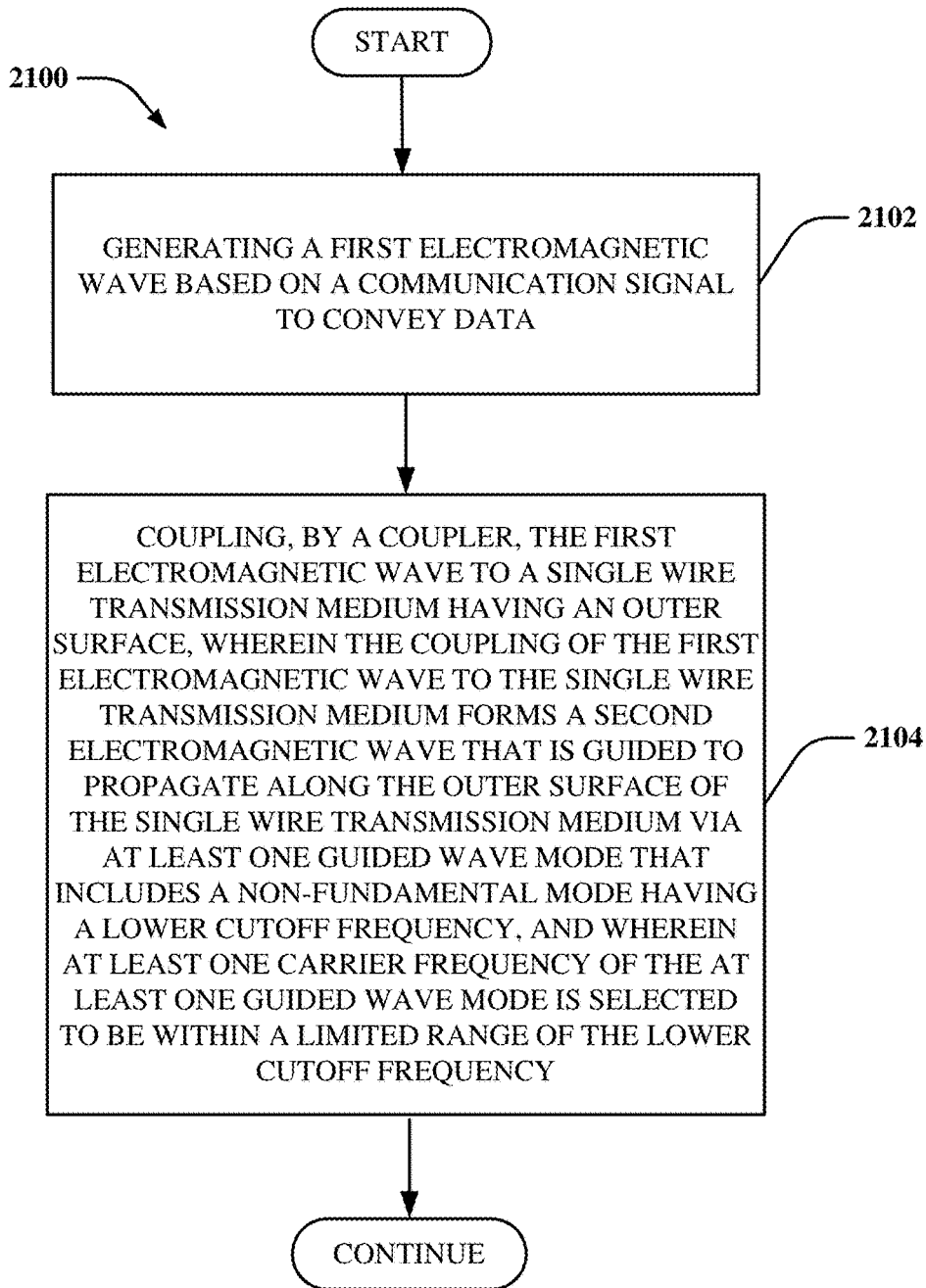

FIG. 21

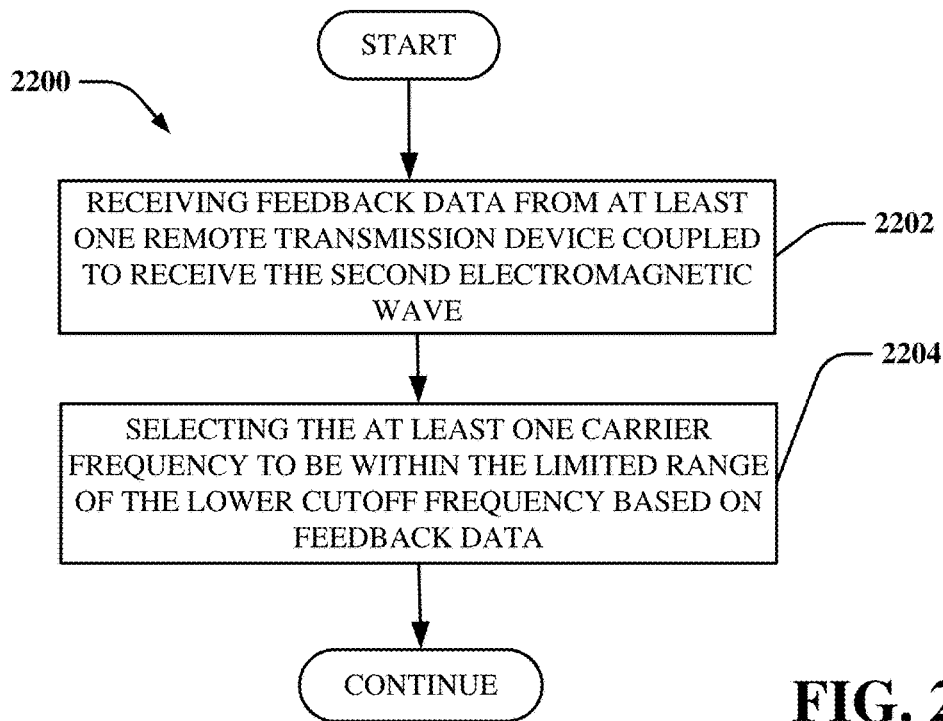

FIG. 22

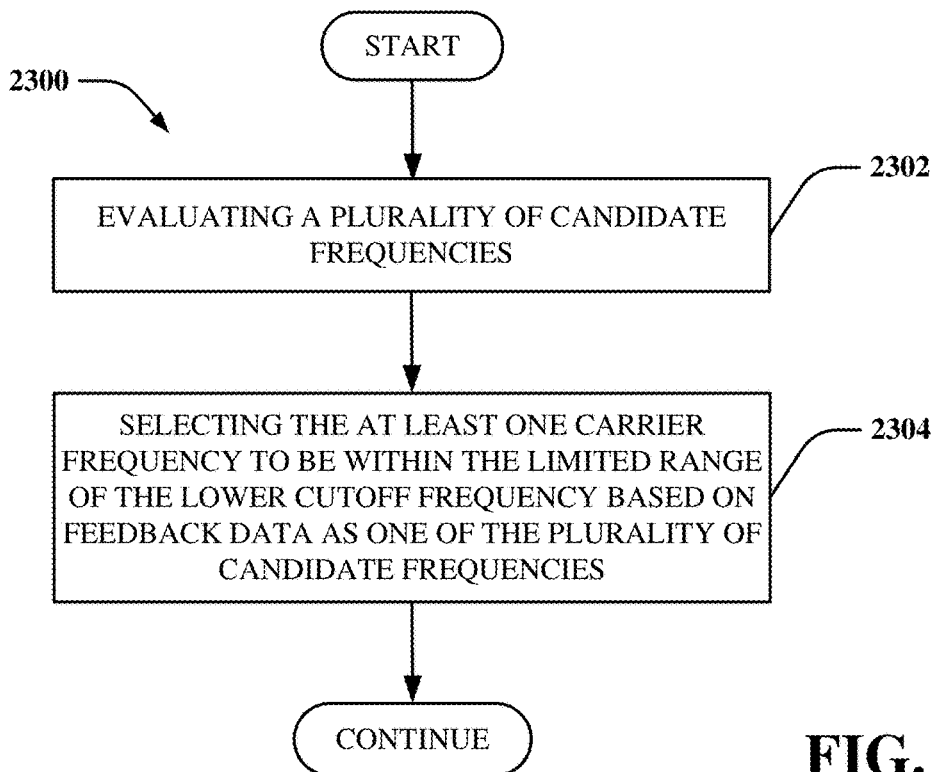

FIG. 23

GUIDED-WAVE TRANSMISSION DEVICE AND METHODS FOR USE THEREWITH

CROSS-REFERENCE TO RELATED APPLICATIONS

This application claims priority and is a continuation of U.S. patent application Ser. No. 15/070,041 filed Mar. 15, 2016, which is a continuation of and claims priority to U.S. patent application Ser. No. 14/519,566 filed Oct. 21, 2014. The contents of the foregoing are hereby incorporated by reference into this application as if set forth herein in full.

FIELD OF THE DISCLOSURE

The subject disclosure relates to communications via microwave transmission in a communication network.

BACKGROUND

As smart phones and other portable devices increasingly become ubiquitous, and data usage increases, macrocell base station devices and existing wireless infrastructure in turn require higher bandwidth to address the increased demand. To provide additional mobile bandwidth, small cell deployment is being pursued, with microcells and picocells providing coverage for much smaller areas than traditional macrocells.

BRIEF DESCRIPTION OF THE DRAWINGS

FIG. 1 is a block diagram illustrating an example, non-limiting embodiment of a guided-wave communications system in accordance with various aspects described herein.

FIG. 2 is a block diagram illustrating an example, non-limiting embodiment of a dielectric waveguide coupler in accordance with various aspects described herein.

FIG. 3 is a block diagram illustrating an example, non-limiting embodiment of a dielectric waveguide coupler in accordance with various aspects described herein.

FIG. 4 is a block diagram illustrating an example, non-limiting embodiment of a dielectric waveguide coupler in accordance with various aspects described herein.

FIG. 5 is a block diagram illustrating an example, non-limiting embodiment of a dielectric waveguide coupler and transceiver in accordance with various aspects described herein.

FIG. 6 is a block diagram illustrating an example, non-limiting embodiment of a dual dielectric waveguide coupler in accordance with various aspects described herein.

FIG. 7 is a block diagram illustrating an example, non-limiting embodiment of a bidirectional dielectric waveguide coupler in accordance with various aspects described herein.

FIG. 8 illustrates a block diagram illustrating an example, non-limiting embodiment of a bidirectional dielectric waveguide coupler in accordance with various aspects described herein.

FIG. 9 illustrates a block diagram illustrating an example, non-limiting embodiment of a bidirectional repeater system in accordance with various aspects described herein.

FIG. 10 illustrates a flow diagram of an example, non-limiting embodiment of a method for transmitting a transmission with a dielectric waveguide coupler as described herein.

FIG. 11 is a block diagram of an example, non-limiting embodiment of a computing environment in accordance with various aspects described herein.

FIG. 12 is a block diagram of an example, non-limiting embodiment of a mobile network platform in accordance with various aspects described herein.

FIGS. 13a, 13b, and 13c are block diagrams illustrating example, non-limiting embodiments of a slotted waveguide coupler in accordance with various aspects described herein.

FIGS. 14a and 14b are a block diagrams illustrating an example, non-limiting embodiment of a waveguide coupling system in accordance with various aspects described herein.

FIG. 15 is a block diagram illustrating an example, non-limiting embodiment of a guided-wave communication system in accordance with various aspects described herein.

FIG. 16 is a block diagram illustrating an example, non-limiting embodiment of a transmission device in accordance with various aspects described herein.

FIG. 17 is a diagram illustrating an example, non-limiting embodiment of an electromagnetic distribution in accordance with various aspects described herein.

FIG. 18 is a diagram illustrating example, non-limiting embodiments of various electromagnetic distributions in accordance with various aspects described herein.

FIG. 19 is a block diagram illustrating an example, non-limiting embodiment of a transmission device in accordance with various aspects described herein.

FIG. 20 illustrates a flow diagram of an example, non-limiting embodiment of a method of transmission as described herein.

FIG. 21 illustrates a flow diagram of an example, non-limiting embodiment of a method of transmission as described herein.

FIG. 22 illustrates a flow diagram of an example, non-limiting embodiment of a method of selecting a carrier frequency as described herein.

FIG. 23 illustrates a flow diagram of an example, non-limiting embodiment of a method of selecting a carrier frequency as described herein.

DETAILED DESCRIPTION

One or more embodiments are now described with reference to the drawings, wherein like reference numerals are used to refer to like elements throughout. In the following description, for purposes of explanation, numerous details are set forth in order to provide a thorough understanding of the various embodiments. It is evident, however, that the various embodiments can be practiced in different combinations and without these details (and without applying to any particular networked environment or standard).

To provide network connectivity to additional base station devices, the backhaul network that links the communication cells (e.g., macrocells and microcells) to network devices of the core network correspondingly expands. Similarly, to provide network connectivity to a distributed antenna system, an extended communication system that links base station devices and their distributed antennas is desirable. A guided-wave communication system can be provided to enable alternative, increased or additional network connectivity and a waveguide coupling system can be provided to transmit and/or receive guided-wave (e.g., surface wave) communications on a transmission medium, such as a wire or other conductor that operates as a single-wire transmission line or a dielectric material that operates as a waveguide and/or another transmission medium that otherwise operates to guide the transmission of an electromagnetic wave.

In an example embodiment, a waveguide coupler that is utilized in a waveguide coupling system can be made of a dielectric material, or other low-loss insulator (e.g., Teflon,

polyethylene, etc.), or can be made of a conducting (e.g., metallic, non-metallic, etc.) material, or any combination of the foregoing materials. Reference throughout the detailed description to “dielectric waveguide” is for illustration purposes and does not limit embodiments to being constructed solely of dielectric materials. In other embodiments, other dielectric or insulating materials are possible. It will be appreciated that a variety of transmission media such as: wires, whether insulated or not, and whether single-stranded or multi-stranded; conductors of other shapes or configurations including wire bundles, cables, rods, rails, pipes; non-conductors such as dielectric pipes, rods, rails, or other dielectric members; combinations of conductors and dielectric materials; or other guided-wave transmission media can be utilized with guided-wave communications without departing from example embodiments.

For these and/or other considerations, in one or more embodiments, a transmission device includes a communications interface that receives a first communication signal that includes first data. A transceiver generates a first electromagnetic wave based on the first communication signal to convey the first data, the first electromagnetic wave having at least one carrier frequency and at least one corresponding wavelength. A coupler couples the first electromagnetic wave to a transmission medium having at least one inner portion surrounded by a dielectric material, the dielectric material having an outer surface and a corresponding circumference, wherein the coupling of the first electromagnetic wave to the transmission medium forms a second electromagnetic wave that is guided to propagate along the outer surface of the dielectric material via at least one guided-wave mode that includes an asymmetric mode, wherein the at least one carrier frequency is within a microwave or millimeter-wave frequency band with a corresponding wavelength or wavelengths that is/are less than the circumference of the transmission medium.

In one or more embodiments, a transmission device includes a transmitter that generates a first electromagnetic wave based on a communication signal to convey data, the first electromagnetic wave having at least one carrier frequency and at least one corresponding wavelength. A coupler couples the first electromagnetic wave to a single wire transmission medium having an outer surface and a corresponding circumference, wherein the coupling of the first electromagnetic wave to the single wire transmission medium forms a second electromagnetic wave that is guided to propagate along the outer surface of the single wire transmission medium via at least one guided-wave mode that includes an asymmetric mode, wherein the at least one carrier frequency is within a millimeter-wave or microwave frequency band with a corresponding wavelength or wavelengths that is/are less than the circumference of the single wire transmission medium.

In one or more embodiments, a method includes generating a first electromagnetic wave based on a communication signal to convey data, the first electromagnetic wave having at least one carrier frequency and at least one corresponding wavelength. A coupler couples the first electromagnetic wave to a single wire transmission medium having an outer dielectric surface and a corresponding circumference, wherein the coupling of the first electromagnetic wave to the single wire transmission medium forms a second electromagnetic wave that is guided to propagate along the outer dielectric surface of the single wire transmission medium via at least one guided-wave mode, wherein the at least one carrier frequency is within a millimeter-wave frequency band with a corresponding

wavelength or wavelength(s) that is/are less than the circumference of the single wire transmission medium. The propagation along the outer surface of the single wire transmission medium can be made possible by, for example, a field structure that lies primarily or substantially outside of the transmission medium that serves to guide the wave.

In one or more embodiments, a transmission device includes a transmitter that generates a first electromagnetic wave to convey data. A coupler couples the first electromagnetic wave to a single wire transmission medium having an outer surface, forming a second electromagnetic wave that is guided to propagate along the outer surface of the single wire transmission medium via at least one guided wave mode that includes an asymmetric or non-fundamental mode having a lower cutoff frequency. A carrier frequency of the second electromagnetic wave is selected to be within a limited range of the lower cutoff frequency, so that a majority of the electric field is concentrated within a distance from the outer surface that is less than half the largest cross sectional dimension of the single wire transmission medium, and/or to reduce propagation loss. In one or more embodiments, a method includes generating a first electromagnetic wave to convey data. A coupler couples the first electromagnetic wave to a single wire transmission medium having an outer surface, forming a second electromagnetic wave that is guided to propagate along the outer surface of the single wire transmission medium via at least one guided wave mode that includes an asymmetric or non-fundamental mode having a lower cutoff frequency. A carrier frequency of the second electromagnetic wave is selected to be within a limited range of the lower cutoff frequency, so that a majority of the electric field is concentrated within a distance from the outer surface that is less than half the largest cross sectional dimension of the single wire transmission medium, and/or to reduce propagation loss.

In one or more embodiments, a method includes generating a first electromagnetic wave based on a communication signal to convey data, the first electromagnetic wave having at least one carrier frequency. The first electromagnetic wave is coupled to a single wire transmission medium having an outer surface, wherein the coupling of the first electromagnetic wave to the single wire transmission medium forms a second electromagnetic wave that is guided to propagate along the outer surface of the single wire transmission medium via at least one guided-wave mode that includes an asymmetric mode having a lower cutoff frequency, and wherein the carrier frequency or frequencies is/are selected to be within a limited range of the lower cutoff frequency.

Various embodiments described herein relate to a transmission system for launching and extracting guided-wave (e.g., surface wave communications that are electromagnetic waves) transmissions from a wire. At microwave or millimeter-wave frequencies, wherein the wavelength is small compared to the size of the equipment, transmissions can propagate as waves guided by a waveguide, such as a strip or length of dielectric material or other coupler. The electromagnetic field structure of the guided-wave can be inside and/or outside of the coupler. When this coupler is brought into close proximity to a transmission medium (e.g., a wire, utility line or other transmission medium), at least a portion of the guided-wave decouples from the waveguide and couples to the transmission medium, and continues to propagate as guided-waves, such as surface waves about the surface of the wire.

According to an example embodiment, a surface wave is a type of guided-wave that is guided by a surface of the

transmission medium, which can include an exterior or outer surface of the wire, exterior or outer surface of dielectric coating or insulating jacket, or another surface of a transmission medium that is adjacent to or exposed to another type of medium having different properties (e.g., dielectric properties). Indeed, in an example embodiment, a surface of the transmission medium that guides a surface wave can represent a transitional surface between two different types of media. For example, in the case of a bare or uninsulated wire, the surface of the wire can be the outer or exterior conductive surface of the bare or uninsulated wire that is exposed to air or free space. As another example, in the case of insulated wire, the surface of the wire can be the conductive portion of the wire that meets the insulator portion of the wire, or can otherwise be the insulated surface of the wire that is exposed to air or free space, or can otherwise be any material region between the insulated surface of the wire and the conductive portion of the wire that meets the insulator portion of the wire, depending upon the relative differences in the properties (e.g., dielectric properties) of the insulator, air, and/or the conductor and further dependent on the frequency and propagation mode or modes of the guided-wave.

According to an example embodiment, guided-waves such as surface waves can be contrasted with radio transmissions over free space/air or conventional propagation of electrical power or signals through the conductor of the wire. Indeed, with surface wave or guided-wave systems described herein, conventional electrical power or signals can still propagate or be transmitted through the conductor of the wire, while guided-waves (including surface waves and other electromagnetic waves) can surround all or part of the surface of the wire and propagate along the wire with low loss, according to an example embodiment. In an example embodiment, a surface wave can have a field structure (e.g., an electromagnetic field structure) that lies primarily or substantially outside of the transmission medium that serves to guide the surface wave.

In an example embodiment, the guided-waves employed herein can be contrasted with Sommerfeld waves used as a means of propagation along a wire which are limited to waves having a wavelength greater than, not less than, the circumference of the wire. In an example embodiment, the guided-waves employed herein can be contrasted with G-Wave and E-Wave systems that operate via the propagation of the fundamental mode and not based on the propagation of at least one asymmetric mode. In an example embodiment, the guided-waves employed herein can be contrasted with surface plasmon wave propagation along single metal wire premised on the electron bunches that form in conductors at frequencies such as optical frequencies, well above, and not less than γ , the mean collision frequency of electrons of the conducting material. These prior art systems have failed to address guided-wave propagation for a transmission medium, where the guided-wave includes an asymmetric mode that propagates at low loss frequencies, such as in the microwave or millimeter-wave band, that are less than the mean collision frequency of electrons of the conducting material. These prior art systems have failed to address guided-wave propagation for a transmission medium that includes an outer dielectric, where the guided-wave includes an asymmetric mode that propagates with low loss with fields concentrated about the outer surface of the dielectric.

According to an example embodiment, the electromagnetic waves traveling along a wire are induced by other electromagnetic waves traveling along a waveguide in prox-

imity to the wire. The inducement of the electromagnetic waves can be independent of any electrical potential, charge or current that is injected or otherwise transmitted through the wires as part of an electrical circuit. It is to be appreciated that while a small current in the wire may be formed in response to the propagation of the electromagnetic wave through the wire, this can be due to the propagation of the electromagnetic wave along the wire surface, and is not formed in response to electrical potential, charge or current that is injected into the wire as part of an electrical circuit. The electromagnetic waves traveling on the wire therefore do not require a circuit to propagate along the wire surface. The wire therefore is a single wire transmission line that does not require a circuit. Also, in some embodiments, a wire is not necessary, and the electromagnetic waves can propagate along a single line transmission medium that is not a wire.

According to an example embodiment, the term "single wire transmission medium" is used in conjunction with transmission via electromagnetic waves that are guided by a wire, but do not require the wire to be part of a circuit to support such propagation. A transmission system may include multiple single wire transmission media that act to transmit such guided-waves, with different waves being guided by differing ones of the single wire transmission media.

According to an example embodiment, the term "about" a wire used in conjunction with a guided-wave (e.g., surface wave) can include fundamental wave propagation modes and other guided-waves. Assuming the wire has a circular or otherwise substantially circular cross section, the fundamental mode is a symmetric mode having a circular or substantially circular field distribution (e.g., electric field, magnetic field, electromagnetic field, etc.) at least partially around a wire. In addition, when a guided-wave propagates "about" a circular, stranded or other wire with a circular or substantially circular cross section, it propagates longitudinally along the wire via a wave propagation mode (at least one guided-wave mode) that can include not only the fundamental wave propagation modes (e.g., zero order modes), but additionally or alternatively other non-fundamental wave propagation modes such as higher-order guided-wave modes (e.g., 1st order modes, 2nd order modes, etc.), asymmetrical modes and/or other guided (e.g., surface) waves that have non-circular field distributions around a wire. As used herein, the term "substantially circular" means a shape that varies by less than (+/-15%) from a perfect circle. As used herein, the term "non-circular", means a shape that is not substantially circular.

For example, such non-circular field distributions can be unilateral or multi-lateral with one or more axial lobes characterized by relatively higher field strength and/or one or more nulls or null regions characterized by relatively low-field strength, zero-field strength or substantially zero field strength. Further, the field distribution can otherwise vary as a function of a longitudinal axial orientation around the wire such that one or more regions of axial orientation around the wire have an electric or magnetic field strength (or combination thereof) that is higher than one or more other regions of axial orientation, according to an example embodiment. It will be appreciated that the relative positions of the higher order modes or asymmetrical modes can vary as the guided-wave travels along the wire.

Considering other wires, conductors or dielectrics that have non-circular cross sections (i.e. not substantially circular cross sections), the terms symmetric and asymmetric modes may not apply in the same fashion. For example a

fundamental mode of a rectangular waveguide may not have a circular or substantially circular field distribution. So the terms fundamental mode and non-fundamental modes can be used in this more general sense.

Referring now to FIG. 1, a block diagram illustrating an example, non-limiting embodiment of a guided-wave communication system 100 is shown. Guided-wave communication system 100 depicts an exemplary environment in which a transmission device, coupler or coupling module can be used.

Guided-wave communication system 100 can be a distributed antenna system that includes one or more base station devices (e.g., base station device 104) that are communicably coupled to a macrocell site 102 or other network connection. Base station device 104 can be connected by a wired (e.g., fiber and/or cable), or by a wireless (e.g., microwave wireless) connection to macrocell site 102. Macrocells such as macrocell site 102 can have dedicated connections to the mobile network and base station device 104 can share and/or otherwise use macrocell site 102's connection. Base station device 104 can be mounted on, or attached to, utility pole 116. In other embodiments, base station device 104 can be near transformers and/or other locations situated nearby a power line.

Base station device 104 can facilitate connectivity to a mobile network for mobile devices 122 and 124. Antennas 112 and 114, mounted on or near utility poles 118 and 120, respectively, can receive signals from base station device 104 and transmit those signals to mobile devices 122 and 124 over a much wider area than if the antennas 112 and 114 were located at or near base station device 104.

It is noted that FIG. 1 displays three utility poles, with one base station device, for purposes of simplicity. In other embodiments, utility pole 116 can have more base station devices, and one or more utility poles with distributed antennas are possible.

A transmission device, such as dielectric waveguide coupling device 106 can transmit the signal from base station device 104 to antennas 112 and 114 via utility or power line(s) that connect the utility poles 116, 118, and 120. To transmit the signal, radio source and/or coupler 106 up converts the signal (e.g., via frequency mixing) from base station device 104 or otherwise converts the signal from the base station device 104 to a microwave or millimeter-wave band signal having at least one carrier frequency in the microwave or millimeter-wave frequency band. The dielectric waveguide coupling device 106 launches a millimeter-wave band wave that propagates as a guided-wave (e.g., surface wave or other electromagnetic wave) traveling along the utility line or other wire. At utility pole 118, another transmission device, such as dielectric waveguide coupling device 108 that receives the guided-wave (and optionally can amplify it as needed or desired or operate as a digital repeater to receive it and regenerate it) and sends it forward as a guided-wave (e.g., surface wave or other electromagnetic wave) on the utility line or other wire. The dielectric waveguide coupling device 108 can also extract a signal from the millimeter-wave band guided-wave and shift it down in frequency or otherwise convert it to its original cellular band frequency (e.g., 1.9 GHz or other defined cellular frequency) or another cellular (or non-cellular) band frequency. An antenna 112 can transmit (e.g., wirelessly transmit) the downshifted signal to mobile device 122. The process can be repeated by another transmission device, such as dielectric waveguide coupling device 110, antenna 114 and mobile device 124, as necessary or desirable.

Transmissions from mobile devices 122 and 124 can also be received by antennas 112 and 114 respectively. Repeaters on dielectric waveguide coupling devices 108 and 110 can upshift or otherwise convert the cellular band signals to microwave or millimeter-wave band and transmit the signals as guided-wave (e.g., surface wave or other electromagnetic wave) transmissions over the power line(s) to base station device 104.

In an example embodiment, system 100 can employ diversity paths, where two or more utility lines or other wires are strung between the utility poles 116, 118, and 120 (e.g., for example, two or more wires between poles 116 and 120) and redundant transmissions from base station 104 are transmitted as guided-waves down the surface of the utility lines or other wires. The utility lines or other wires can be either insulated or uninsulated, and depending on the environmental conditions that cause transmission losses, the coupling devices can selectively receive signals from the insulated or uninsulated utility lines or other wires. The selection can be based on measurements of the signal-to-noise ratio of the wires, or based on determined weather/environmental conditions (e.g., moisture detectors, weather forecasts, etc.). The use of diversity paths with system 100 can enable alternate routing capabilities, load balancing, increased load handling, concurrent bi-directional or synchronous communications, spread spectrum communications, etc. (See FIG. 8 for more illustrative details).

It is noted that the use of the dielectric waveguide coupling devices 106, 108, and 110 in FIG. 1 are by way of example only, and that in other embodiments, other uses are possible. For instance, dielectric waveguide coupling devices can be used in a backhaul communication system, providing network connectivity to base station devices. Dielectric waveguide coupling devices can be used in many circumstances where it is desirable to transmit guided-wave communications over a wire, whether insulated or not insulated. Dielectric waveguide coupling devices are improvements over other coupling devices due to no contact or limited physical and/or electrical contact with the wires that may carry high voltages. With dielectric waveguide coupling devices, the apparatus can be located away from the wire (e.g., spaced apart from the wire) and/or located on the wire so long as it is not electrically in contact with the wire, as the dielectric acts as an insulator, allowing for cheap, easy, and/or less complex installation. However, as previously noted conducting or non-dielectric couplers can be employed, particularly in configurations where the wires correspond to a telephone network, cable television network, broadband data service, fiber optic communications system or other network employing low voltages or having insulated transmission lines.

It is further noted, that while base station device 104 and macrocell site 102 are illustrated in an example embodiment, other network configurations are likewise possible. For example, devices such as access points or other wireless gateways can be employed in a similar fashion to extend the reach of other networks such as a wireless local area network, a wireless personal area network or other wireless network that operates in accordance with a communication protocol such as a 802.11 protocol, WIMAX protocol, Ultra Wideband protocol, Bluetooth protocol, Zigbee protocol or other wireless protocol.

Turning now to FIG. 2, illustrated is a block diagram of an example, non-limiting embodiment of a dielectric waveguide coupling system 200 in accordance with various aspects described herein. System 200 comprises a dielectric waveguide 204 that has a wave 206 propagating as a

guided-wave about a waveguide surface of the dielectric waveguide 204. In an example embodiment, the dielectric waveguide 204 is curved, and at least a portion of the waveguide 204 can be placed near a wire 202 in order to facilitate coupling between the waveguide 204 and the wire 202, as described herein. The dielectric waveguide 204 can be placed such that a portion of the curved dielectric waveguide 204 is parallel or substantially parallel to the wire 202. The portion of the dielectric waveguide 204 that is parallel to the wire can be an apex of the curve, or any point where a tangent of the curve is parallel to the wire 202. When the dielectric waveguide 204 is positioned or placed thusly, the wave 206 travelling along the dielectric waveguide 204 couples, at least in part, to the wire 202, and propagates as guided-wave 208 around or about the wire surface of the wire 202 and longitudinally along the wire 202. The guided-wave 208 can be characterized as a surface wave or other electromagnetic wave, although other types of guided-waves 208 can supported as well without departing from example embodiments. A portion of the wave 206 that does not couple to the wire 202 propagates as wave 210 along the dielectric waveguide 204. It will be appreciated that the dielectric waveguide 204 can be configured and arranged in a variety of positions in relation to the wire 202 to achieve a desired level of coupling or non-coupling of the wave 206 to the wire 202. For example, the curvature and/or length of the dielectric waveguide 204 that is parallel or substantially parallel, as well as its separation distance (which can include zero separation distance in an example embodiment), to the wire 202 can be varied without departing from example embodiments. Likewise, the arrangement of the dielectric waveguide 204 in relation to the wire 202 may be varied based upon considerations of the respective intrinsic characteristics (e.g., thickness, composition, electromagnetic properties, etc.) of the wire 202 and the dielectric waveguide 204, as well as the characteristics (e.g., frequency, energy level, etc.) of the waves 206 and 208.

The guided-wave 208 propagates in a direction parallel or substantially parallel to the wire 202, even as the wire 202 bends and flexes. Bends in the wire 202 can increase transmission losses, which are also dependent on wire diameters, frequency, and materials. If the dimensions of the dielectric waveguide 204 are chosen for efficient power transfer, most of the power in the wave 206 is transferred to the wire 202, with little power remaining in wave 210. It will be appreciated that the guided-wave 208 can still be multimodal in nature (discussed herein), including having modes that are non-fundamental or asymmetric, while traveling along a path that is parallel or substantially parallel to the wire 202, with or without a fundamental transmission mode. In an example embodiment, non-fundamental or asymmetric modes can be utilized to minimize transmission losses and/or obtain increased propagation distances.

It is noted that the term parallel is generally a geometric construct which often is not exactly achievable in real systems. Accordingly, the term parallel as utilized in the subject disclosure represents an approximation rather than an exact configuration when used to describe embodiments disclosed in the subject disclosure. In an example embodiment, substantially parallel can include approximations that are within 30 degrees of true parallel in all dimensions.

In an example embodiment, the wave 206 can exhibit one or more wave propagation modes. The dielectric waveguide modes can be dependent on the shape and/or design of the waveguide 204. The one or more dielectric waveguide modes of wave 206 can generate, influence, or impact one or more wave propagation modes of the guided-wave 208

propagating along wire 202. In an example embodiment, the wave propagation modes on the wire 202 can be similar to the dielectric waveguide modes since both waves 206 and 208 propagate about the outside of the dielectric waveguide 204 and wire 202 respectively. In some embodiments, as the wave 206 couples to the wire 202, the modes can change form due to the coupling between the dielectric waveguide 204 and the wire 202. For example, differences in size, material, and/or impedances of the dielectric waveguide 204 and the wire 202 may create additional modes not present in the dielectric waveguide modes and/or suppress some of the dielectric waveguide modes. The wave propagation modes can comprise the fundamental transverse electromagnetic mode (Quasi-TEM₀₀), where only small electric and/or magnetic fields extend in the direction of propagation, and the electric and magnetic fields extend radially outwards while the guided-wave propagates along the wire. This guided-wave mode can be donut shaped, where few of the electromagnetic fields exist within the dielectric waveguide 204 or wire 202. Waves 206 and 208 can comprise a fundamental TEM mode where the fields extend radially outwards, and also comprise other, non-fundamental (e.g., asymmetric, higher-level, etc.) modes. While particular wave propagation modes are discussed above, other wave propagation modes are likewise possible such as transverse electric (TE) and transverse magnetic (TM) modes, based on the frequencies employed, the design of the dielectric waveguide 204, the dimensions and composition of the wire 202, as well as its surface characteristics, its optional insulation, the electromagnetic properties of the surrounding environment, etc. It should be noted that, depending on the frequency, the electrical and physical characteristics of the wire 202 and the particular wave propagation modes that are generated, the guided-wave 208 can travel along the conductive surface of an oxidized uninsulated wire, an unoxidized uninsulated wire, an insulated wire and/or along the insulating surface of an insulated wire.

In an example embodiment, a diameter of the dielectric waveguide 204 is smaller than the diameter of the wire 202. For the microwave or millimeter-band wavelength being used, the dielectric waveguide 204 supports a single waveguide mode that makes up wave 206. This single waveguide mode can change as it couples to the wire 202 as surface wave 208. If the dielectric waveguide 204 were larger, more than one waveguide mode can be supported, but these additional waveguide modes may not couple to the wire 202 as efficiently, and higher coupling losses can result. However, in some alternative embodiments, the diameter of the dielectric waveguide 204 can be equal to or larger than the diameter of the wire 202, for example, where higher coupling losses are desirable or when used in conjunction with other techniques to otherwise reduce coupling losses (e.g., impedance matching with tapering, etc.).

In an example embodiment, the wavelength of the waves 206 and 208 are comparable in size, or smaller than a circumference of the dielectric waveguide 204 and the wire 202. In an example, if the wire 202 has a diameter of 0.5 cm, and a corresponding circumference of around 1.5 cm, the wavelength of the transmission is around 1.5 cm or less, corresponding to a frequency of 20 GHz or greater. In another embodiment, a suitable frequency of the transmission and the carrier-wave signal is in the range of 30-100 GHz, perhaps around 30-60 GHz, and around 38 GHz in one example. In an example embodiment, when the circumference of the dielectric waveguide 204 and wire 202 is comparable in size to, or greater, than a wavelength of the transmission, the waves 206 and 208 can exhibit multiple

wave propagation modes including fundamental and/or non-fundamental (symmetric and/or asymmetric) modes that propagate over sufficient distances to support various communication systems described herein. The waves **206** and **208** can therefore comprise more than one type of electric and magnetic field configuration. In an example embodiment, as the guided-wave **208** propagates down the wire **202**, the electrical and magnetic field configurations will remain the same from end to end of the wire **202**. In other embodiments, as the guided-wave **208** encounters interference or loses energy due to transmission losses, the electric and magnetic field configurations can change as the guided-wave **208** propagates down wire **202**.

In an example embodiment, the dielectric waveguide **204** can be composed of nylon, Teflon, polyethylene, a polyamide, or other plastics. In other embodiments, other dielectric materials are possible. The wire surface of wire **202** can be metallic with either a bare metallic surface, or can be insulated using plastic, dielectric, insulator or other sheathing. In an example embodiment, a dielectric or otherwise non-conducting/insulated waveguide can be paired with either a bare/metallic wire or insulated wire. In other embodiments, a metallic and/or conductive waveguide can be paired with a bare/metallic wire or insulated wire. In an example embodiment, an oxidation layer on the bare metallic surface of the wire **202** (e.g., resulting from exposure of the bare metallic surface to oxygen/air) can also provide insulating or dielectric properties similar to those provided by some insulators or sheathings.

It is noted that the graphical representations of waves **206**, **208** and **210** are presented merely to illustrate the principles that wave **206** induces or otherwise launches a guided-wave **208** on a wire **202** that operates, for example, as a single wire transmission line. Wave **210** represents the portion of wave **206** that remains on the dielectric waveguide **204** after the generation of guided-wave **208**. The actual electric and magnetic fields generated as a result of such wave propagation may vary depending on the frequencies employed, the particular wave propagation mode or modes, the design of the dielectric waveguide **204**, the dimensions and composition of the wire **202**, as well as its surface characteristics, its optional insulation, the electromagnetic properties of the surrounding environment, etc.

It is noted that dielectric waveguide **204** can include a termination circuit or damper **214** at the end of the dielectric waveguide **204** that can absorb leftover radiation or energy from wave **210**. The termination circuit or damper **214** can prevent and/or minimize the leftover radiation from wave **210** reflecting back toward transmitter circuit **212**. In an example embodiment, the termination circuit or damper **214** can include termination resistors, and/or other components that perform impedance matching to attenuate reflection. In some embodiments, if the coupling efficiencies are high enough, and/or wave **210** is sufficiently small, it may not be necessary to use a termination circuit or damper **214**. For the sake of simplicity, these transmitter and termination circuits or dampers **212** and **214** are not depicted in the other figures, but in those embodiments, transmitter and termination circuits or dampers may possibly be used.

Further, while a single dielectric waveguide **204** is presented that generates a single guided-wave **208**, multiple dielectric waveguides **204** placed at different points along the wire **202** and/or at different axial orientations about the wire can be employed to generate and receive multiple guided-waves **208** at the same or different frequencies, at the same or different phases, and/or at the same or different wave propagation modes. The guided-wave or waves **208**

can be modulated to convey data via a modulation technique such as phase shift keying, frequency shift keying, quadrature amplitude modulation, amplitude modulation, multi-carrier modulation and via multiple access techniques such as frequency division multiplexing, time division multiplexing, code division multiplexing, multiplexing via differing wave propagation modes and via other modulation and access strategies.

Turning now to FIG. 3, illustrated is a block diagram of an example, non-limiting embodiment of a dielectric waveguide coupling system **300** in accordance with various aspects described herein. System **300** implements a coupler that comprises a dielectric waveguide **304** and a wire **302** that has a wave **306** propagating as a guided-wave about a wire surface of the wire **302**. In an example embodiment, the wave **306** can be characterized as a surface wave or other electromagnetic wave.

In an example embodiment, the dielectric waveguide **304** is curved or otherwise has a curvature, and can be placed near a wire **302** such that a portion of the curved dielectric waveguide **304** is parallel or substantially parallel to the wire **302**. The portion of the dielectric waveguide **304** that is parallel to the wire can be an apex of the curve, or any point where a tangent of the curve is parallel to the wire **302**. When the dielectric waveguide **304** is near the wire, the guided-wave **306** travelling along the wire **302** can couple to the dielectric waveguide **304** and propagate as guided-wave **308** about the dielectric waveguide **304**. A portion of the guided-wave **306** that does not couple to the dielectric waveguide **304** propagates as guided-wave **310** (e.g., surface wave or other electromagnetic wave) along the wire **302**.

The guided-waves **306** and **308** stay parallel to the wire **302** and dielectric waveguide **304**, respectively, even as the wire **302** and dielectric waveguide **304** bend and flex. Bends can increase transmission losses, which are also dependent on wire diameters, frequency, and materials. If the dimensions of the dielectric waveguide **304** are chosen for efficient power transfer, most of the energy in the guided-wave **306** is coupled to the dielectric waveguide **304** and little remains in guided-wave **310**.

In an example embodiment, a receiver circuit can be placed on the end of waveguide **304** in order to receive wave **308**. A termination circuit can be placed on the opposite end of the waveguide **304** in order to receive guided-waves traveling in the opposite direction to guided-wave **306** that couple to the waveguide **304**. The termination circuit would thus prevent and/or minimize reflections being received by the receiver circuit. If the reflections are small, the termination circuit may not be necessary.

It is noted that the dielectric waveguide **304** can be configured such that selected polarizations of the surface wave **306** are coupled to the dielectric waveguide **304** as guided-wave **308**. For instance, if guided-wave **306** is made up of guided-waves or wave propagation modes with respective polarizations, dielectric waveguide **304** can be configured to receive one or more guided-waves of selected polarization(s). Guided-wave **308** that couples to the dielectric waveguide **304** is thus the set of guided-waves that correspond to one or more of the selected polarization(s), and further guided-wave **310** can comprise the guided-waves that do not match the selected polarization(s).

The dielectric waveguide **304** can be configured to receive guided-waves of a particular polarization based on an angle/rotation around the wire **302** that the dielectric waveguide **304** is placed (the axial orientation of the coupler) and the axial pattern of the field structure of the guided-waves. For instance, if the coupler is oriented to feed the guided-waves

along the horizontal access and if the guided-wave **306** is polarized horizontally (i.e. the filed structure of the guided-waves are concentrated on the horizontal axis), most of the guided-wave **306** transfers to the dielectric waveguide as wave **308**. In another instance, if the dielectric waveguide **304** is rotated 90 degrees around the wire **302**, most of the energy from guided-wave **306** would remain coupled to the wire as guided-wave **310**, and only a small portion would couple to the wire **302** as wave **308**.

It is noted that waves **306**, **308**, and **310** are shown using three circular symbols in FIG. **3** and in other figures in the specification. These symbols are used to represent a general guided-wave, but do not imply that the waves **306**, **308**, and **310** are necessarily circularly polarized or otherwise circularly oriented. In fact, waves **306**, **308**, and **310** can comprise a fundamental TEM mode where the fields extend radially outwards, and also comprise other, non-fundamental (e.g. higher-level, etc.) modes. These modes can be asymmetric (e.g., radial, bilateral, trilateral, quadrilateral, etc.) in nature as well.

It is noted also that guided-wave communications over wires can be full duplex, allowing simultaneous communications in both directions. Waves traveling one direction can pass through waves traveling in an opposite direction. Electromagnetic fields may cancel out at certain points and for short times due to the superposition principle as applied to waves. The waves traveling in opposite directions propagate as if the other waves weren't there, but the composite effect to an observer may be a stationary standing wave pattern. As the guided-waves pass through each other and are no longer in a state of superposition, the interference subsides. As a guided-wave (e.g., surface wave or other electromagnetic wave) couples to a waveguide and moves away from the wire, any interference due to other guided-waves (e.g., surface waves or other electromagnetic waves) decreases. In an example embodiment, as guided-wave **306** (e.g., surface wave or other electromagnetic wave) approaches dielectric waveguide **304**, another guided-wave (e.g., surface wave or other electromagnetic wave) (not shown) traveling from left to right on the wire **302** passes by causing local interference. As guided-wave **306** couples to dielectric waveguide **304** as wave **308**, and moves away from the wire **302**, any interference due to the passing guided-wave subsides.

It is noted that the graphical representations of electromagnetic waves **306**, **308** and **310** are presented merely to illustrate the principles that guided-wave **306** induces or otherwise launches a wave **308** on a dielectric waveguide **304**. Guided-wave **310** represents the portion of guided-wave **306** that remains on the wire **302** after the generation of wave **308**. The actual electric and magnetic fields generated as a result of such guided-wave propagation may vary depending on one or more of the shape and/or design of the dielectric waveguide, the relative position of the dielectric waveguide to the wire, the frequencies employed, the design of the dielectric waveguide **304**, the dimensions and composition of the wire **302**, as well as its surface characteristics, its optional insulation, the electromagnetic properties of the surrounding environment, etc.

Turning now to FIG. **4**, illustrated is a block diagram of an example, non-limiting embodiment of a dielectric waveguide coupling system **400** in accordance with various aspects described herein. System **400** implements a coupler that comprises a dielectric waveguide **404** that has a wave **406** propagating as a guided-wave about a waveguide surface of the dielectric waveguide **404**. In an example embodiment, the dielectric waveguide **404** is curved, and an end of the dielectric waveguide **404** can be tied, fastened, or

otherwise mechanically coupled to a wire **402**. When the end of the dielectric waveguide **404** is fastened to the wire **402**, the end of the dielectric waveguide **404** is parallel or substantially parallel to the wire **402**. Alternatively, another portion of the dielectric waveguide beyond an end can be fastened or coupled to wire **402** such that the fastened or coupled portion is parallel or substantially parallel to the wire **402**. The coupling device **410** can be a nylon cable tie or other type of non-conducting/dielectric material that is either separate from the dielectric waveguide **404** or constructed as an integrated component of the dielectric waveguide **404**. In other embodiments, the dielectric waveguide **404** can be mechanically uncoupled from the wire **402** leaving an air gap between the coupler and the wire **402**. The dielectric waveguide **404** can be adjacent to the wire **402** without surrounding the wire **402**.

When the dielectric waveguide **404** is placed with the end parallel to the wire **402**, the guided-wave **406** travelling along the dielectric waveguide **404** couples to the wire **402**, and propagates as guided-wave **408** about the wire surface of the wire **402**. In an example embodiment, the guided-wave **408** can be characterized as a surface wave or other electromagnetic wave.

It is noted that the graphical representations of waves **406** and **408** are presented merely to illustrate the principles that wave **406** induces or otherwise launches a guided-wave **408** on a wire **402** that operates, for example, as a single wire transmission line. The actual electric and magnetic fields generated as a result of such wave propagation may vary depending on one or more of the shape and/or design of the dielectric waveguide, the relative position of the dielectric waveguide to the wire, the frequencies employed, the design of the dielectric waveguide **404**, the dimensions and composition of the wire **402**, as well as its surface characteristics, its optional insulation, the electromagnetic properties of the surrounding environment, etc.

In an example embodiment, an end of dielectric waveguide **404** can taper towards the wire **402** in order to increase coupling efficiencies. Indeed, the tapering of the end of the dielectric waveguide **404** can provide impedance matching to the wire **402**, according to an example embodiment of the subject disclosure. For example, an end of the dielectric waveguide **404** can be gradually tapered in order to obtain a desired level of coupling between waves **406** and **408** as illustrated in FIG. **4**.

In an example embodiment, the coupling device **410** can be placed such that there is a short length of the dielectric waveguide **404** between the coupling device **410** and an end of the dielectric waveguide **404**. Maximum coupling efficiencies are realized when the length of the end of the dielectric waveguide **404** that is beyond the coupling device **410** is at least several wavelengths long for whatever frequency is being transmitted, however shorter lengths are also possible.

Turning now to FIG. **5**, illustrated is a block diagram of an example, non-limiting embodiment of a dielectric waveguide coupler and transceiver system **500** (referred to herein collectively as system **500**) in accordance with various aspects described herein. System **500** implements a transmission device with a coupler that comprises a transmitter/receiver device **506** that launches and receives waves (e.g., guided-wave **504** onto dielectric waveguide **502**). The guided-waves **504** can be used to transport signals received from and sent to a base station device **508**, mobile devices **522**, or a building **524** by way of a communications interface **501**. The communications interface **501** can be an integral part of system **500**. Alternatively, the communications inter-

face **501** can be tethered to system **500**. The communications interface **501** can comprise a wireless interface for interfacing to the base station **508**, the mobile devices **522**, or building **524** utilizing any of various wireless signaling protocols (e.g., LTE, WiFi, WiMAX, etc.). The communications interface **501** can also comprise a wired interface such as a fiber optic line, coaxial cable, twisted pair, or other suitable wired mediums for transmitting signals to the base station **508** or building **524**. For embodiments where system **500** functions as a repeater, the communications interface **501** may not be necessary.

The output signals (e.g., Tx) of the communications interface **501** can be combined with a millimeter-wave carrier wave generated by a local oscillator **512** at frequency mixer **510**. Frequency mixer **510** can use heterodyning techniques or other frequency shifting techniques to frequency shift the output signals from communications interface **501**. For example, signals sent to and from the communications interface **501** can be modulated signals such as orthogonal frequency division multiplexed (OFDM) signals formatted in accordance with a Long-Term Evolution (LTE) wireless protocol or other wireless 3G, 4G, 5G or higher voice and data protocol, a Zigbee, WIMAX, Ultra Wideband or IEEE 802.11 wireless protocol or other wireless protocol. In an example embodiment, this frequency conversion can be done in the analog domain, and as a result, the frequency shifting can be done without regard to the type of communications protocol that the base station **508**, mobile devices **522**, or in-building devices **524** use. As new communications technologies are developed, the communications interface **501** can be upgraded or replaced and the frequency shifting and transmission apparatus can remain, simplifying upgrades. The carrier wave can then be sent to a power amplifier (“PA”) **514** and can be transmitted via the transmitter receiver device **506** via the diplexer **516**.

Signals received from the transmitter/receiver device **506** that are directed towards the communications interface **501** can be separated from other signals via diplexer **516**. The transmission can then be sent to low noise amplifier (“LNA”) **518** for amplification. A frequency mixer **520**, with help from local oscillator **512** can downshift the transmission (which is in the millimeter-wave band or around 38 GHz in some embodiments) to the native frequency. The communications interface **501** can then receive the transmission at an input port (Rx).

In an example embodiment, transmitter/receiver device **506** can include a cylindrical or non-cylindrical metal (which, for example, can be hollow in an example embodiment) or other conducting or non-conducting waveguide and an end of the dielectric waveguide **502** can be placed in or in proximity to the waveguide or the transmitter/receiver device **506** such that when the transmitter/receiver device **506** generates a transmission, the guided-wave couples to dielectric waveguide **502** and propagates as a guided-wave **504** about the waveguide surface of the dielectric waveguide **502**. Similarly, if guided-wave **504** is incoming (coupled to the dielectric waveguide **502** from a wire), guided-wave **504** then enters the transmitter/receiver device **506** and couples to the cylindrical waveguide or conducting waveguide. While transmitter/receiver device **506** is shown to include a separate waveguide—an antenna, cavity resonator, klystron, magnetron, travelling wave tube or other radiating element can be employed to induce a guided-wave on the waveguide **502**, without the separate waveguide.

In an example embodiment, dielectric waveguide **502** can be wholly constructed of a dielectric material (or another suitable insulating material), without any metallic or other-

wise conducting materials therein. Dielectric waveguide **502** can be composed of nylon, Teflon, polyethylene, a polyamide, other plastics, or other materials that are non-conducting and suitable for facilitating transmission of electromagnetic waves on an outer surface of such materials. In another embodiment, dielectric waveguide **502** can include a core that is conducting/metallic, and have an exterior dielectric surface. Similarly, a transmission medium that couples to the dielectric waveguide **502** for propagating electromagnetic waves induced by the dielectric waveguide **502** or for supplying electromagnetic waves to the dielectric waveguide **502** can be wholly constructed of a dielectric material (or another suitable insulating material), without any metallic or otherwise conducting materials therein.

It is noted that although FIG. **5** shows that the opening of transmitter receiver device **506** is much wider than the dielectric waveguide **502**, this is not to scale, and that in other embodiments the width of the dielectric waveguide **502** is comparable or slightly smaller than the opening of the hollow waveguide. It is also not shown, but in an example embodiment, an end of the waveguide **502** that is inserted into the transmitter/receiver device **506** tapers down in order to reduce reflection and increase coupling efficiencies.

The transceiver system **500** can be communicably coupled to a communications interface **501**, and alternatively, transceiver system **500** can also be communicably coupled via the communications interface **501** to the one or more distributed antennas **112** and **114** shown in FIG. **1**. In other embodiments, transceiver system **500** can comprise part of a repeater system for a backhaul network.

Before coupling to the dielectric waveguide **502**, the one or more waveguide modes of the guided-wave generated by the transmitter/receiver device **506** can couple to one or more wave propagation modes of the guided-wave **504**. The wave propagation modes can be different than the hollow metal waveguide modes due to the different characteristics of the hollow metal waveguide and the dielectric waveguide. For instance, wave propagation modes can comprise the fundamental transverse electromagnetic mode (Quasi-TEM₀₀), where only small electrical and/or magnetic fields extend in the direction of propagation, and the electric and magnetic fields extend radially outwards from the wire while the guided-waves propagate along the wire. The fundamental transverse electromagnetic mode wave propagation mode does not exist inside a waveguide that is hollow. Therefore, the hollow metal waveguide modes that are used by the transmitter/receiver device **506** are waveguide modes that can couple effectively and efficiently to wave propagation modes of the dielectric waveguide **502**.

Turning now to FIG. **6**, illustrated is a block diagram illustrating an example, non-limiting embodiment of a dual dielectric waveguide coupling system **600** in accordance with various aspects described herein. In an example embodiment, a coupling module is shown with two or more dielectric waveguides (e.g., **604** and **606**) positioned around a wire **602** in order to receive guided-wave **608**. In an example embodiment, the guided-wave **608** can be characterized as a surface wave or other electromagnetic wave. In an example embodiment, one dielectric waveguide is enough to receive the guided-wave **608**. In that case, guided-wave **608** couples to dielectric waveguide **604** and propagates as guided-wave **610**. If the field structure of the guided-wave **608** oscillates or undulates around the wire **602** due to various outside factors, then dielectric waveguide **606** can be placed such that guided-wave **608** couples to dielectric waveguide **606**. In some embodiments, four or more dielectric waveguides can be placed around a portion of the

wire **602**, e.g., at 90 degrees or another spacing with respect to each other, in order to receive guided-waves that may oscillate or rotate around the wire **602**, that have been induced at different axial orientations or that have non-fundamental or higher order modes that, for example, have lobes and/or nulls or other asymmetries that are orientation dependent. However, it will be appreciated that there may be less than or more than four dielectric waveguides placed around a portion of the wire **602** without departing from example embodiments. It will also be appreciated that while some example embodiments have presented a plurality of dielectric waveguides around at least a portion of a wire **602**, this plurality of dielectric waveguides can also be considered as part of a single dielectric waveguide system having multiple dielectric waveguide subcomponents. For example, two or more dielectric waveguides can be manufactured as single system that can be installed around a wire in a single installation such that the dielectric waveguides are either pre-positioned or adjustable relative to each other (either manually or automatically) in accordance with the single system. Receivers coupled to dielectric waveguides **606** and **604** can use diversity combining to combine signals received from both dielectric waveguides **606** and **604** in order to maximize the signal quality. In other embodiments, if one or the other of a dielectric waveguide **604** and **606** receives a transmission that is above a predetermined threshold, receivers can use selection diversity when deciding which signal to use.

It is noted that the graphical representations of waves **608** and **610** are presented merely to illustrate the principles that guided-wave **608** induces or otherwise launches a wave **610** on a dielectric waveguide **604**. The actual electric and magnetic fields generated as a result of such wave propagation may vary depending on the frequencies employed, the design of the dielectric waveguide **604**, the dimensions and composition of the wire **602**, as well as its surface characteristics, its optional insulation, the electromagnetic properties of the surrounding environment, etc.

Turning now to FIG. 7, illustrated is a block diagram of an example, non-limiting embodiment of a bidirectional dielectric waveguide coupling system **700** in accordance with various aspects described herein. Such a system **700** implements a transmission device with a coupling module that includes two dielectric waveguides **704** and **714** can be placed near a wire **702** such that guided-waves (e.g., surface waves or other electromagnetic waves) propagating along the wire **702** are coupled to dielectric waveguide **704** as wave **706**, and then are boosted or repeated by repeater device **710** and launched as a guided-wave **716** onto dielectric waveguide **714**. The guided-wave **716** can then couple to wire **702** and continue to propagate along the wire **702**. In an example embodiment, the repeater device **710** can receive at least a portion of the power utilized for boosting or repeating through magnetic coupling with the wire **702**, which can be a power line.

In some embodiments, repeater device **710** can repeat the transmission associated with wave **706**, and in other embodiments, repeater device **710** can be associated with a distributed antenna system and/or base station device located near the repeater device **710**. Receiver waveguide **708** can receive the wave **706** from the dielectric waveguide **704** and transmitter waveguide **712** can launch guided-wave **716** onto dielectric waveguide **714**. Between receiver waveguide **708** and transmitter waveguide **712**, the signal can be amplified to correct for signal loss and other inefficiencies associated with guided-wave communications or the signal can be received and processed to extract the data contained

therein and regenerated for transmission. In an example embodiment, a signal can be extracted from the transmission and processed and otherwise emitted to mobile devices nearby via distributed antennas communicably coupled to the repeater device **710**. Similarly, signals and/or communications received by the distributed antennas can be inserted into the transmission that is generated and launched onto dielectric waveguide **714** by transmitter waveguide **712**. Accordingly, the repeater system **700** depicted in FIG. 7 can be comparable in function to the dielectric waveguide coupling device **108** and **110** in FIG. 1.

It is noted that although FIG. 7 shows guided-wave transmissions **706** and **716** entering from the left and exiting to the right respectively, this is merely a simplification and is not intended to be limiting. In other embodiments, receiver waveguide **708** and transmitter waveguide **712** can also function as transmitters and receivers respectively, allowing the repeater device **710** to be bi-directional.

In an example embodiment, repeater device **710** can be placed at locations where there are discontinuities or obstacles on the wire **702**. These obstacles can include transformers, connections, utility poles, and other such power line devices. The repeater device **710** can help the guided (e.g., surface) waves jump over these obstacles on the line and boost the transmission power at the same time. In other embodiments, a dielectric waveguide can be used to jump over the obstacle without the use of a repeater device. In that embodiment, both ends of the dielectric waveguide can be tied or fastened to the wire, thus providing a path for the guided-wave to travel without being blocked by the obstacle.

Turning now to FIG. 8, illustrated is a block diagram of an example, non-limiting embodiment of a bidirectional dielectric waveguide coupler **800** in accordance with various aspects described herein. The bidirectional dielectric waveguide coupler **800** implements a transmission device with a coupling module that can employ diversity paths in the case of when two or more wires are strung between utility poles. Since guided-wave transmissions have different transmission efficiencies and coupling efficiencies for insulated wires and un-insulated wires based on weather, precipitation and atmospheric conditions, it can be advantageous to selectively transmit on either an insulated wire or un-insulated wire at certain times.

In the embodiment shown in FIG. 8, the repeater device uses a receiver waveguide **808** to receive a guided-wave traveling along un-insulated wire **802** and repeats the transmission using transmitter waveguide **810** as a guided-wave along insulated wire **804**. In other embodiments, repeater device can switch from the insulated wire **804** to the un-insulated wire **802**, or can repeat the transmissions along the same paths. Repeater device **806** can include sensors, or be in communication with sensors that indicate conditions that can affect the transmission. Based on the feedback received from the sensors, the repeater device **806** can make the determination about whether to keep the transmission along the same wire, or transfer the transmission to the other wire.

Turning now to FIG. 9, illustrated is a block diagram illustrating an example, non-limiting embodiment of a bidirectional repeater system **900**. Bidirectional repeater system **900** implements a transmission device with a coupling module that includes waveguide coupling devices **902** and **904** that receive and transmit transmissions from other coupling devices located in a distributed antenna system or backhaul system.

In various embodiments, waveguide coupling device **902** can receive a transmission from another waveguide coupling device, wherein the transmission has a plurality of subcarriers. Diplexer **906** can separate the transmission from other transmissions, for example by filtration, and direct the transmission to low-noise amplifier (“LNA”) **908**. A frequency mixer **928**, with help from a local oscillator **912**, can downshift the transmission (which is in the millimeter-wave band or around 38 GHz in some embodiments) to a lower frequency, whether it is a cellular band (~1.9 GHz) for a distributed antenna system, a native frequency, or other frequency for a backhaul system. An extractor **932** can extract the signal on the subcarrier that corresponds to the antenna or other output component **922** and direct the signal to the output component **922**. For the signals that are not being extracted at this antenna location, extractor **932** can redirect them to another frequency mixer **936**, where the signals are used to modulate a carrier wave generated by local oscillator **914**. The carrier wave, with its subcarriers, is directed to a power amplifier (“PA”) **916** and is retransmitted by waveguide coupling device **904** to another repeater system, via diplexer **920**.

At the output device **922**, a PA **924** can boost the signal for transmission to the mobile device. An LNA **926** can be used to amplify weak signals that are received from the mobile device and then send the signal to a multiplexer **934** which merges the signal with signals that have been received from waveguide coupling device **904**. The output device **922** can be coupled to an antenna in a distributed antenna system or other antenna via, for example, a diplexer, duplexer or a transmit receive switch not specifically shown. The signals received from coupling device **904** have been split by diplexer **920**, and then passed through LNA **918**, and downshifted in frequency by frequency mixer **938**. When the signals are combined by multiplexer **934**, they are upshifted in frequency by frequency mixer **930**, and then boosted by PA **910**, and transmitted back to the launcher or on to another repeater by waveguide coupling device **902**. In an example embodiment, the bidirectional repeater system **900** can be just a repeater without the antenna/output device **922**. It will be appreciated that in some embodiments, a bidirectional repeater system **900** could also be implemented using two distinct and separate uni-directional repeaters. In an alternative embodiment, a bidirectional repeater system **900** could also be a booster or otherwise perform retransmissions without downshifting and upshifting. Indeed in example embodiment, the retransmissions can be based upon receiving a signal or guided-wave and performing some signal or guided-wave processing or reshaping, filtering, and/or amplification, prior to retransmission of the signal or guided-wave.

FIG. **10** illustrates a process in connection with the aforementioned systems. The process in FIG. **10** can be implemented for example by systems **100**, **200**, **300**, **400**, **500**, **600**, **700**, **800**, and **900** illustrated in FIGS. **1-9** respectively. While for purposes of simplicity of explanation, the methods are shown and described as a series of blocks, it is to be understood and appreciated that the claimed subject matter is not limited by the order of the blocks, as some blocks may occur in different orders and/or concurrently with other blocks from what is depicted and described herein. Moreover, not all illustrated blocks may be required to implement the methods described hereinafter.

FIG. **10** illustrates a flow diagram of an example, non-limiting embodiment of a method for transmitting a transmission with a dielectric waveguide coupler as described herein. Method **1000** can begin at **1002** where a first

electromagnetic wave is emitted by a transmission device that propagates at least in part on a waveguide surface of a waveguide, wherein the waveguide surface of the waveguide does not surround in whole or in substantial part a wire surface of a wire. The transmission that is generated by a transmitter can be based on a signal received from a base station device, access point, network or a mobile device.

At **1004**, based upon configuring the waveguide in proximity of the wire, the guided-wave then couples at least a part of the first electromagnetic wave to a wire surface, forming a second electromagnetic wave (e.g., a surface wave) that propagates at least partially around the wire surface, wherein the wire is in proximity to the waveguide. This can be done in response to positioning a portion of the dielectric waveguide (e.g., a tangent of a curve of the dielectric waveguide) near and parallel to the wire, wherein a wavelength of the electromagnetic wave is smaller than a circumference of the wire and the dielectric waveguide. The guided-wave, or surface wave, stays parallel to the wire even as the wire bends and flexes. Bends can increase transmission losses, which are also dependent on wire diameters, frequency, and materials. The coupling interface between the wire and the waveguide can also be configured to achieve the desired level of coupling, as described herein, which can include tapering an end of the waveguide to improve impedance matching between the waveguide and the wire.

The transmission that is emitted by the transmitter can exhibit one or more waveguide modes. The waveguide modes can be dependent on the shape and/or design of the waveguide. The propagation modes on the wire can be different than the waveguide modes due to the different characteristics of the waveguide and the wire. When the circumference of the wire is comparable in size to, or greater, than a wavelength of the transmission, the guided-wave exhibits multiple wave propagation modes. The guided-wave can therefore comprise more than one type of electric and magnetic field configuration. As the guided-wave (e.g., surface wave) propagates down the wire, the electrical and magnetic field configurations may remain substantially the same from end to end of the wire or vary as the transmission traverses the wave by rotation, dispersion, attenuation or other effects.

Referring now to FIG. **11**, there is illustrated a block diagram of a computing environment in accordance with various aspects described herein. In order to provide additional context for various embodiments of the embodiments described herein, FIG. **11** and the following discussion are intended to provide a brief, general description of a suitable computing environment **1100** in which the various embodiments of the embodiment described herein can be implemented. While the embodiments have been described above in the general context of computer-executable instructions that can be run on one or more computers, those skilled in the art will recognize that the embodiments can be also implemented in combination with other program modules and/or as a combination of hardware and software.

Generally, program modules comprise routines, programs, components, data structures, etc., that perform particular tasks or implement particular abstract data types. Moreover, those skilled in the art will appreciate that the inventive methods can be practiced with other computer system configurations, comprising single-processor or multiprocessor computer systems, minicomputers, mainframe computers, as well as personal computers, hand-held computing devices, microprocessor-based or programmable con-

sumer electronics, and the like, each of which can be operatively coupled to one or more associated devices.

The terms “first,” “second,” “third,” and so forth, as used in the claims, unless otherwise clear by context, is for clarity only and doesn’t otherwise indicate or imply any order in time. For instance, “a first determination,” “a second determination,” and “a third determination,” does not indicate or imply that the first determination is to be made before the second determination, or vice versa, etc.

The illustrated embodiments of the embodiments herein can be also practiced in distributed computing environments where certain tasks are performed by remote processing devices that are linked through a communications network. In a distributed computing environment, program modules can be located in both local and remote memory storage devices.

Computing devices typically comprise a variety of media, which can comprise computer-readable storage media and/or communications media, which two terms are used herein differently from one another as follows. Computer-readable storage media can be any available storage media that can be accessed by the computer and comprises both volatile and nonvolatile media, removable and non-removable media. By way of example, and not limitation, computer-readable storage media can be implemented in connection with any method or technology for storage of information such as computer-readable instructions, program modules, structured data or unstructured data.

Computer-readable storage media can comprise, but are not limited to, random access memory (RAM), read only memory (ROM), electrically erasable programmable read only memory (EEPROM), flash memory or other memory technology, compact disk read only memory (CD-ROM), digital versatile disk (DVD) or other optical disk storage, magnetic cassettes, magnetic tape, magnetic disk storage or other magnetic storage devices or other tangible and/or non-transitory media which can be used to store desired information. In this regard, the terms “tangible” or “non-transitory” herein as applied to storage, memory or computer-readable media, are to be understood to exclude only propagating transitory signals per se as modifiers and do not relinquish rights to all standard storage, memory or computer-readable media that are not only propagating transitory signals per se.

Computer-readable storage media can be accessed by one or more local or remote computing devices, e.g., via access requests, queries or other data retrieval protocols, for a variety of operations with respect to the information stored by the medium.

Communications media typically embody computer-readable instructions, data structures, program modules or other structured or unstructured data in a data signal such as a modulated data signal, e.g., a carrier wave or other transport mechanism, and comprise any information delivery or transport media. The term “modulated data signal” or signals refers to a signal that has one or more of its characteristics set or changed in such a manner as to encode information in one or more signals. By way of example, and not limitation, communication media comprise wired media, such as a wired network or direct-wired connection, and wireless media such as acoustic, RF, infrared and other wireless media.

With reference again to FIG. 11, the example environment 1100 for transmitting and receiving signals via base station (e.g., base station devices 104 and 508) and repeater devices (e.g., repeater devices 710, 806, and 900) comprises a computer 1102, the computer 1102 comprising a processing

unit 1104, a system memory 1106 and a system bus 1108. The system bus 1108 couples system components including, but not limited to, the system memory 1106 to the processing unit 1104. The processing unit 1104 can be any of various commercially available processors. Dual microprocessors and other multiprocessor architectures can also be employed as the processing unit 1104.

The system bus 1108 can be any of several types of bus structure that can further interconnect to a memory bus (with or without a memory controller), a peripheral bus, and a local bus using any of a variety of commercially available bus architectures. The system memory 1106 comprises ROM 1110 and RAM 1112. A basic input/output system (BIOS) can be stored in a non-volatile memory such as ROM, erasable programmable read only memory (EPROM), EEPROM, which BIOS contains the basic routines that help to transfer information between elements within the computer 1102, such as during startup. The RAM 1112 can also comprise a high-speed RAM such as static RAM for caching data.

The computer 1102 further comprises an internal hard disk drive (HDD) 1114 (e.g., EIDE, SATA), which internal hard disk drive 1114 can also be configured for external use in a suitable chassis (not shown), a magnetic floppy disk drive (FDD) 1116, (e.g., to read from or write to a removable diskette 1118) and an optical disk drive 1120, (e.g., reading a CD-ROM disk 1122 or, to read from or write to other high capacity optical media such as the DVD). The hard disk drive 1114, magnetic disk drive 1116 and optical disk drive 1120 can be connected to the system bus 1108 by a hard disk drive interface 1124, a magnetic disk drive interface 1126 and an optical drive interface 1128, respectively. The interface 1124 for external drive implementations comprises at least one or both of Universal Serial Bus (USB) and Institute of Electrical and Electronics Engineers (IEEE) 1394 interface technologies. Other external drive connection technologies are within contemplation of the embodiments described herein.

The drives and their associated computer-readable storage media provide nonvolatile storage of data, data structures, computer-executable instructions, and so forth. For the computer 1102, the drives and storage media accommodate the storage of any data in a suitable digital format. Although the description of computer-readable storage media above refers to a hard disk drive (HDD), a removable magnetic diskette, and a removable optical media such as a CD or DVD, it should be appreciated by those skilled in the art that other types of storage media which are readable by a computer, such as zip drives, magnetic cassettes, flash memory cards, cartridges, and the like, can also be used in the example operating environment, and further, that any such storage media can contain computer-executable instructions for performing the methods described herein.

A number of program modules can be stored in the drives and RAM 1112, comprising an operating system 1130, one or more application programs 1132, other program modules 1134 and program data 1136. All or portions of the operating system, applications, modules, and/or data can also be cached in the RAM 1112. The systems and methods described herein can be implemented utilizing various commercially available operating systems or combinations of operating systems. Examples of application programs 1132 that can be implemented and otherwise executed by processing unit 1104 include the diversity selection determining performed by repeater device 806. Base station device 508 shown in FIG. 5, also has stored on memory many appli-

cations and programs that can be executed by processing unit **1104** in this exemplary computing environment **1100**.

A user can enter commands and information into the computer **1102** through one or more wired/wireless input devices, e.g., a keyboard **1138** and a pointing device, such as a mouse **1140**. Other input devices (not shown) can comprise a microphone, an infrared (IR) remote control, a joystick, a game pad, a stylus pen, touch screen or the like. These and other input devices are often connected to the processing unit **1104** through an input device interface **1142** that can be coupled to the system bus **1108**, but can be connected by other interfaces, such as a parallel port, an IEEE 1394 serial port, a game port, a universal serial bus (USB) port, an IR interface, etc.

A monitor **1144** or other type of display device can be also connected to the system bus **1108** via an interface, such as a video adapter **1146**. It will also be appreciated that in alternative embodiments, a monitor **1144** can also be any display device (e.g., another computer having a display, a smart phone, a tablet computer, etc.) for receiving display information associated with computer **1102** via any communication means, including via the Internet and cloud-based networks. In addition to the monitor **1144**, a computer typically comprises other peripheral output devices (not shown), such as speakers, printers, etc.

The computer **1102** can operate in a networked environment using logical connections via wired and/or wireless communications to one or more remote computers, such as a remote computer(s) **1148**. The remote computer(s) **1148** can be a workstation, a server computer, a router, a personal computer, portable computer, microprocessor-based entertainment appliance, a peer device or other common network node, and typically comprises many or all of the elements described relative to the computer **1102**, although, for purposes of brevity, only a memory/storage device **1150** is illustrated. The logical connections depicted comprise wired/wireless connectivity to a local area network (LAN) **1152** and/or larger networks, e.g., a wide area network (WAN) **1154**. Such LAN and WAN networking environments are commonplace in offices and companies, and facilitate enterprise-wide computer networks, such as intranets, all of which can connect to a global communications network, e.g., the Internet.

When used in a LAN networking environment, the computer **1102** can be connected to the local network **1152** through a wired and/or wireless communication network interface or adapter **1156**. The adapter **1156** can facilitate wired or wireless communication to the LAN **1152**, which can also comprise a wireless AP disposed thereon for communicating with the wireless adapter **1156**.

When used in a WAN networking environment, the computer **1102** can comprise a modem **1158** or can be connected to a communications server on the WAN **1154** or has other means for establishing communications over the WAN **1154**, such as by way of the Internet. The modem **1158**, which can be internal or external and a wired or wireless device, can be connected to the system bus **1108** via the input device interface **1142**. In a networked environment, program modules depicted relative to the computer **1102** or portions thereof, can be stored in the remote memory/storage device **1150**. It will be appreciated that the network connections shown are example and other means of establishing a communications link between the computers can be used.

The computer **1102** can be operable to communicate with any wireless devices or entities operatively disposed in wireless communication, e.g., a printer, scanner, desktop and/or portable computer, portable data assistant, commu-

nications satellite, any piece of equipment or location associated with a wirelessly detectable tag (e.g., a kiosk, news stand, restroom), and telephone. This can comprise Wireless Fidelity (Wi-Fi) and BLUETOOTH® wireless technologies. Thus, the communication can be a predefined structure as with a conventional network or simply an ad hoc communication between at least two devices.

Wi-Fi can allow connection to the Internet from a couch at home, a bed in a hotel room or a conference room at work, without wires. Wi-Fi is a wireless technology similar to that used in a cell phone that enables such devices, e.g., computers, to send and receive data indoors and out; anywhere within the range of a base station. Wi-Fi networks use radio technologies called IEEE 802.11 (a, b, g, n, ac, etc.) to provide secure, reliable, fast wireless connectivity. A Wi-Fi network can be used to connect computers to each other, to the Internet, and to wired networks (which can use IEEE 802.3 or Ethernet). Wi-Fi networks operate in the unlicensed 2.4 and 5 GHz radio bands for example or with products that contain both bands (dual band), so the networks can provide real-world performance similar to the basic 10BaseT wired Ethernet networks used in many offices.

FIG. 12 presents an example embodiment **1200** of a mobile network platform **1210** that can implement and exploit one or more aspects of the disclosed subject matter described herein. In one or more embodiments, the mobile network platform **1210** can generate and receive signals transmitted and received by base stations (e.g., base station devices **104** and **508**) and repeater devices (e.g., repeater devices **710**, **806**, and **900**) associated with the disclosed subject matter. Generally, wireless network platform **1210** can comprise components, e.g., nodes, gateways, interfaces, servers, or disparate platforms, that facilitate both packet-switched (PS) (e.g., internet protocol (IP), frame relay, asynchronous transfer mode (ATM)) and circuit-switched (CS) traffic (e.g., voice and data), as well as control generation for networked wireless telecommunication. As a non-limiting example, wireless network platform **1210** can be included in telecommunications carrier networks, and can be considered carrier-side components as discussed elsewhere herein. Mobile network platform **1210** comprises CS gateway node(s) **1212** which can interface CS traffic received from legacy networks like telephony network(s) **1240** (e.g., public switched telephone network (PSTN), or public land mobile network (PLMN)) or a signaling system #7 (SS7) network **1260**. Circuit switched gateway node(s) **1212** can authorize and authenticate traffic (e.g., voice) arising from such networks. Additionally, CS gateway node (s) **1212** can access mobility, or roaming, data generated through SS7 network **1260**; for instance, mobility data stored in a visited location register (VLR), which can reside in memory **1230**. Moreover, CS gateway node(s) **1212** interfaces CS-based traffic and signaling and PS gateway node(s) **1218**. As an example, in a 3GPP UMTS network, CS gateway node(s) **1212** can be realized at least in part in gateway GPRS support node(s) (GGSN). It should be appreciated that functionality and specific operation of CS gateway node(s) **1212**, PS gateway node(s) **1218**, and serving node(s) **1216**, is provided and dictated by radio technology (ies) utilized by mobile network platform **1210** for telecommunication.

In addition to receiving and processing CS-switched traffic and signaling, PS gateway node(s) **1218** can authorize and authenticate PS-based data sessions with served mobile devices. Data sessions can comprise traffic, or content(s), exchanged with networks external to the wireless network platform **1210**, like wide area network(s) (WANs) **1250**,

enterprise network(s) **1270**, and service network(s) **1280**, which can be embodied in local area network(s) (LANs), can also be interfaced with mobile network platform **1210** through PS gateway node(s) **1218**. It is to be noted that WANs **1250** and enterprise network(s) **1270** can embody, at least in part, a service network(s) like IP multimedia sub-system (IMS). Based on radio technology layer(s) available in technology resource(s), packet-switched gateway node(s) **1218** can generate packet data protocol contexts when a data session is established; other data structures that facilitate routing of packetized data also can be generated. To that end, in an aspect, PS gateway node(s) **1218** can comprise a tunnel interface (e.g., tunnel termination gateway (TTG) in 3GPP UMTS network(s) (not shown)) which can facilitate packetized communication with disparate wireless network(s), such as Wi-Fi networks.

In embodiment **1200**, wireless network platform **1210** also comprises serving node(s) **1216** that, based upon available radio technology layer(s) within technology resource (s), convey the various packetized flows of data streams received through PS gateway node(s) **1218**. It is to be noted that for technology resource(s) that rely primarily on CS communication, server node(s) can deliver traffic without reliance on PS gateway node(s) **1218**; for example, server node(s) can embody at least in part a mobile switching center. As an example, in a 3GPP UMTS network, serving node(s) **1216** can be embodied in serving GPRS support node(s) (SGSN).

For radio technologies that exploit packetized communication, server(s) **1214** in wireless network platform **1210** can execute numerous applications that can generate multiple disparate packetized data streams or flows, and manage (e.g., schedule, queue, format . . .) such flows. Such application(s) can comprise add-on features to standard services (for example, provisioning, billing, customer support . . .) provided by wireless network platform **1210**. Data streams (e.g., content(s) that are part of a voice call or data session) can be conveyed to PS gateway node(s) **1218** for authorization/authentication and initiation of a data session, and to serving node(s) **1216** for communication thereafter. In addition to application server, server(s) **1214** can comprise utility server(s), a utility server can comprise a provisioning server, an operations and maintenance server, a security server that can implement at least in part a certificate authority and firewalls as well as other security mechanisms, and the like. In an aspect, security server(s) secure communication served through wireless network platform **1210** to ensure network's operation and data integrity in addition to authorization and authentication procedures that CS gateway node(s) **1212** and PS gateway node(s) **1218** can enact. Moreover, provisioning server(s) can provision services from external network(s) like networks operated by a disparate service provider; for instance, WAN **1250** or Global Positioning System (GPS) network(s) (not shown). Provisioning server(s) can also provision coverage through networks associated to wireless network platform **1210** (e.g., deployed and operated by the same service provider), such as the distributed antennas networks shown in FIG. 1(s) that enhance wireless service coverage by providing more network coverage. Repeater devices such as those shown in FIGS. 7, 8, and 9 also improve network coverage in order to enhance subscriber service experience by way of UE **1275**.

It is to be noted that server(s) **1214** can comprise one or more processors configured to confer at least in part the functionality of macro network platform **1210**. To that end, the one or more processor can execute code instructions stored in memory **1230**, for example. It is should be appre-

ciated that server(s) **1214** can comprise a content manager, which operates in substantially the same manner as described hereinbefore.

In example embodiment **1200**, memory **1230** can store information related to operation of wireless network platform **1210**. Other operational information can comprise provisioning information of mobile devices served through wireless platform network **1210**, subscriber databases; application intelligence, pricing schemes, e.g., promotional rates, flat-rate programs, couponing campaigns; technical specification(s) consistent with telecommunication protocols for operation of disparate radio, or wireless, technology layers; and so forth. Memory **1230** can also store information from at least one of telephony network(s) **1240**, WAN **1250**, enterprise network(s) **1270**, or SS7 network **1260**. In an aspect, memory **1230** can be, for example, accessed as part of a data store component or as a remotely connected memory store.

In order to provide a context for the various aspects of the disclosed subject matter, FIG. 12, and the following discussion, are intended to provide a brief, general description of a suitable environment in which the various aspects of the disclosed subject matter can be implemented. While the subject matter has been described above in the general context of computer-executable instructions of a computer program that runs on a computer and/or computers, those skilled in the art will recognize that the disclosed subject matter also can be implemented in combination with other program modules. Generally, program modules comprise routines, programs, components, data structures, etc. that perform particular tasks and/or implement particular abstract data types.

Turning now to FIGS. 13a, 13b, and 13c, illustrated are block diagrams of example, non-limiting embodiments of a slotted waveguide coupler system **1300** in accordance with various aspects described herein. In particular, cross sections of various waveguides are presented near the junction where the waveguide launches a guided-wave along a wire. In FIG. 13a, the waveguide coupler system comprises a wire **1306** that is positioned with respect to a waveguide **1302**, such that the wire **1306** fits within or near a slot formed in the waveguide **1302** that runs longitudinally with respect to the wire **1306**. The opposing ends **1304a** and **1304b** of the waveguide **1302**, and the waveguide **1302** itself, surrounds less than 180 degrees of the wire surface of the wire **1306**.

In FIG. 13b the waveguide coupler system comprises a wire **1314** that is positioned with respect to a waveguide **1308**, such that the wire **1314** fits within or near a slot formed in the waveguide **1308** that runs longitudinally with respect to the wire **1314**. The slot surfaces of the waveguide **1308** can be non-parallel, and two different exemplary embodiments are shown in FIG. 13b. In the first, slot surfaces **1310a** and **1310b** can be non-parallel and aim outwards, slightly wider than the width of the wire **1314**. In the other embodiment, the slots surfaces **1312a** and **1312b** can still be non-parallel, but narrow to form a slot opening smaller than a width of the wire **1314**. Any range of angles of the non-parallel slot surfaces are possible, of which these are two exemplary embodiments.

In FIG. 13c, the waveguide coupler system shows a wire **1320** that fits within a slot formed in waveguide **1316**. The slot surfaces **1318a** and **1318b** in this exemplary embodiment can be parallel, but the axis **1326** of the wire **1320** is not aligned with the axis **1324** of the waveguide **1316**. The waveguide **1316** and the wire **1320** are therefore not coaxially aligned. In another embodiment, shown, a possible

position of the wire at **1322** also has an axis **1328** that is not aligned with the axis **1324** of the waveguide **1316**.

It is to be appreciated that while three different embodiments showing a) waveguide surfaces that surround less than 180 degrees of the wire, b) non parallel slot surfaces, and c) coaxially unaligned wires and waveguide were shown separately in FIGS. **13a**, **13b**, and **13c**, in various embodiments, diverse combinations of the listed features are possible.

Turning now to FIG. **14**, illustrated is an example, non-limiting embodiment of a waveguide coupling system **1400** in accordance with various aspects described herein. FIG. **14** depicts a cross sectional representation of the waveguide and wire embodiments shown in FIGS. **2**, **3**, **4**, etc. As can be seen in **1400**, the wire **1404** can be positioned directly next to and touching waveguide **1402**. In other embodiments, as shown in waveguide coupling system **1410** in FIG. **14b**, the wire **1414** can still be placed near, but not actually touching waveguide strip **1412**. In both cases, electromagnetic waves traveling along the waveguides can induce other electromagnetic waves on to the wires and vice versa. Also, in both embodiments, the wires **1404** and **1414** are placed outside the cross-sectional area defined by the outer surfaces of waveguides **1402** and **1412**.

For the purposes of this disclosure, a waveguide does not surround, in substantial part, a wire surface of a wire when the waveguide does not surround an axial region of the surface, when viewed in cross-section, of more than 180 degrees. For avoidance of doubt, a waveguide does not surround, in substantial part a surface of a wire when the waveguide surrounds an axial region of the surface, when viewed in cross-section, of 180 degrees or less.

It is to be appreciated that while FIGS. **14** and **14b** show wires **1404** and **1414** having a circular shape and waveguides **1402** and **1412** having rectangular shapes, this is not meant to be limiting. In other embodiments, wires and waveguides can have a variety of shapes, sizes, and configurations. The shapes can include, but not be limited to: ovals or other ellipsoid shapes, octagons, quadrilaterals or other polygons with either sharp or rounded edges, or other shapes. Additionally, in some embodiments, the wires **1404** and **1414** can be stranded wires comprising smaller gauge wires, such as a helical strand, braid or other coupling of individual strands into a single wire. Any of wires and waveguides shown in the figures and described throughout this disclosure can include one or more of these embodiments.

In the subject specification, terms such as “store,” “storage,” “data store,” data storage,” “database,” and substantially any other information storage component relevant to operation and functionality of a component, refer to “memory components,” or entities embodied in a “memory” or components comprising the memory. It will be appreciated that the memory components described herein can be either volatile memory or nonvolatile memory, or can comprise both volatile and nonvolatile memory, by way of illustration, and not limitation, volatile memory, non-volatile memory, disk storage, and memory storage. Further, non-volatile memory can be included in read only memory (ROM), programmable ROM (PROM), electrically programmable ROM (EPROM), electrically erasable ROM (EEPROM), or flash memory. Volatile memory can comprise random access memory (RAM), which acts as external cache memory. By way of illustration and not limitation, RAM is available in many forms such as synchronous RAM (SRAM), dynamic RAM (DRAM), synchronous DRAM (SDRAM), double data rate SDRAM (DDR SDRAM),

enhanced SDRAM (ESDRAM), Synchlink DRAM (SLDRAM), and direct Rambus RAM (DRRAM). Additionally, the disclosed memory components of systems or methods herein are intended to comprise, without being limited to comprising, these and any other suitable types of memory.

Moreover, it will be noted that the disclosed subject matter can be practiced with other computer system configurations, comprising single-processor or multiprocessor computer systems, mini-computing devices, mainframe computers, as well as personal computers, hand-held computing devices (e.g., PDA, phone, watch, tablet computers, netbook computers, etc.), microprocessor-based or programmable consumer or industrial electronics, and the like. The illustrated aspects can also be practiced in distributed computing environments where tasks are performed by remote processing devices that are linked through a communications network; however, some if not all aspects of the subject disclosure can be practiced on stand-alone computers. In a distributed computing environment, program modules can be located in both local and remote memory storage devices.

Some of the embodiments described herein can also employ artificial intelligence (AI) to facilitate automating one or more features described herein. For example, artificial intelligence can be used to determine positions around a wire that dielectric waveguides **604** and **606** should be placed in order to maximize transfer efficiency. The embodiments (e.g., in connection with automatically identifying acquired cell sites that provide a maximum value/benefit after addition to an existing communication network) can employ various AI-based schemes for carrying out various embodiments thereof. Moreover, the classifier can be employed to determine a ranking or priority of the each cell site of the acquired network. A classifier is a function that maps an input attribute vector, $x=(x_1, x_2, x_3, x_4, \dots, x_n)$, to a confidence that the input belongs to a class, that is, $f(x)=\text{confidence}(\text{class})$. Such classification can employ a probabilistic and/or statistical-based analysis (e.g., factoring into the analysis utilities and costs) to prognose or infer an action that a user desires to be automatically performed. A support vector machine (SVM) is an example of a classifier that can be employed. The SVM operates by finding a hypersurface in the space of possible inputs, which the hypersurface attempts to split the triggering criteria from the non-triggering events. Intuitively, this makes the classification correct for testing data that is near, but not identical to training data. Other directed and undirected model classification approaches comprise, e.g., naïve Bayes, Bayesian networks, decision trees, neural networks, fuzzy logic models, and probabilistic classification models providing different patterns of independence that can be employed. Classification as used herein also is inclusive of statistical regression that is utilized to develop models of priority.

As will be readily appreciated, one or more of the embodiments can employ classifiers that are explicitly trained (e.g., via a generic training data) as well as implicitly trained (e.g., via observing UE behavior, operator preferences, historical information, receiving extrinsic information). For example, SVMs can be configured via a learning or training phase within a classifier constructor and feature selection module. Thus, the classifier(s) can be used to automatically learn and perform a number of functions, including but not limited to determining according to a predetermined criteria which of the acquired cell sites will benefit a maximum number of subscribers and/or which of the acquired cell sites will add minimum value to the existing communication network coverage, etc.

As used in some contexts in this application, in some embodiments, the terms “component”, “system” and the like are intended to refer to, or comprise, a computer-related entity or an entity related to an operational apparatus with one or more specific functionalities, wherein the entity can be either hardware, a combination of hardware and software, software, or software in execution. As an example, a component may be, but is not limited to being, a process running on a processor, a processor, an object, an executable, a thread of execution, computer-executable instructions, a program, and/or a computer. By way of illustration and not limitation, both an application running on a server and the server can be a component. One or more components may reside within a process and/or thread of execution and a component may be localized on one computer and/or distributed between two or more computers. In addition, these components can execute from various computer readable media having various data structures stored thereon. The components may communicate via local and/or remote processes such as in accordance with a signal having one or more data packets (e.g., data from one component interacting with another component in a local system, distributed system, and/or across a network such as the Internet with other systems via the signal). As another example, a component can be an apparatus with specific functionality provided by mechanical parts operated by electric or electronic circuitry, which is operated by a software or firmware application executed by a processor, wherein the processor can be internal or external to the apparatus and executes at least a part of the software or firmware application. As yet another example, a component can be an apparatus that provides specific functionality through electronic components without mechanical parts, the electronic components can comprise a processor therein to execute software or firmware that confers at least in part the functionality of the electronic components. While various components have been illustrated as separate components, it will be appreciated that multiple components can be implemented as a single component, or a single component can be implemented as multiple components, without departing from example embodiments.

Further, the various embodiments can be implemented as a method, apparatus or article of manufacture using standard programming and/or engineering techniques to produce software, firmware, hardware or any combination thereof to control a computer to implement the disclosed subject matter. The term “article of manufacture” as used herein is intended to encompass a computer program accessible from any computer-readable device or computer-readable storage/communications media. For example, computer readable storage media can include, but are not limited to, magnetic storage devices (e.g., hard disk, floppy disk, magnetic strips), optical disks (e.g., compact disk (CD), digital versatile disk (DVD)), smart cards, and flash memory devices (e.g., card, stick, key drive). Of course, those skilled in the art will recognize many modifications can be made to this configuration without departing from the scope or spirit of the various embodiments.

In addition, the words “example” and “exemplary” are used herein to mean serving as an instance or illustration. Any embodiment or design described herein as “example” or “exemplary” is not necessarily to be construed as preferred or advantageous over other embodiments or designs. Rather, use of the word example or exemplary is intended to present concepts in a concrete fashion. As used in this application, the term “or” is intended to mean an inclusive “or” rather than an exclusive “or”. That is, unless specified

otherwise or clear from context, “X employs A or B” is intended to mean any of the natural inclusive permutations. That is, if X employs A; X employs B; or X employs both A and B, then “X employs A or B” is satisfied under any of the foregoing instances. In addition, the articles “a” and “an” as used in this application and the appended claims should generally be construed to mean “one or more” unless specified otherwise or clear from context to be directed to a singular form.

Moreover, terms such as “user equipment,” “mobile station,” “mobile,” subscriber station,” “access terminal,” “terminal,” “handset,” “mobile device” (and/or terms representing similar terminology) can refer to a wireless device utilized by a subscriber or user of a wireless communication service to receive or convey data, control, voice, video, sound, gaming or substantially any data-stream or signaling-stream. The foregoing terms are utilized interchangeably herein and with reference to the related drawings.

Furthermore, the terms “user,” “subscriber,” “customer,” “consumer” and the like are employed interchangeably throughout, unless context warrants particular distinctions among the terms. It should be appreciated that such terms can refer to human entities or automated components supported through artificial intelligence (e.g., a capacity to make inference based, at least, on complex mathematical formalisms), which can provide simulated vision, sound recognition and so forth.

As employed herein, the term “processor” can refer to substantially any computing processing unit or device comprising, but not limited to comprising, single-core processors; single-processors with software multithread execution capability; multi-core processors; multi-core processors with software multithread execution capability; multi-core processors with hardware multithread technology; parallel platforms; and parallel platforms with distributed shared memory. Additionally, a processor can refer to an integrated circuit, an application specific integrated circuit (ASIC), a digital signal processor (DSP), a field programmable gate array (FPGA), a programmable logic controller (PLC), a complex programmable logic device (CPLD), a discrete gate or transistor logic, discrete hardware components or any combination thereof designed to perform the functions described herein. Processors can exploit nano-scale architectures such as, but not limited to, molecular and quantum-dot based transistors, switches and gates, in order to optimize space usage or enhance performance of user equipment. A processor can also be implemented as a combination of computing processing units.

Turning now to FIG. 15, a block diagram is shown illustrating an example, non-limiting embodiment of a guided-wave communication system 1500. In operation, a transmission device 1500 receives one or more communication signals 1510 from a communication network or other communications device that include data and generates guided waves 1520 to convey the data via the transmission medium 1525 to the transmission device 1502. The transmission device 1502 receives the guided waves 1520 and converts them to communication signals 1512 that include the data for transmission to a communications network or other communications device. The communication network or networks can include a wireless communication network such as a mobile data network, a cellular voice and data network, a wireless local area network (e.g., WiFi or an 802.xx network), a satellite communications network, a personal area network or other wireless network. The communication network or networks can include a wired communication network such as a telephone network, an Eth-

ernet network, a local area network, a wide area network such as the Internet, a broadband access network, a cable network, a fiber optic network, or other wired network. The communication devices can include a network edge device, bridge device or home gateway, a set-top box, broadband modem, telephone adapter, access point, base station, or other fixed communication device, a mobile communication device such as an automotive gateway, laptop computer, tablet, smartphone, cellular telephone, or other communication device.

In an example embodiment, the guided-wave communication system **1550** can operate in a bi-directional fashion where transmission device **1500** receives one or more communication signals **1512** from a communication network or device that includes other data and generates guided-waves **1522** to convey the other data via the transmission medium **1525** to the transmission device **1500**. In this mode of operation, the transmission device **1502** receives the guided-waves **1522** and converts them to communication signals **1510** that include the other data for transmission to a communications network or device.

The transmission medium **1525** can include a wire or other conductor or inner portion having at least one inner portion surrounded by a dielectric material such as an insulator or other dielectric cover, coating or other dielectric material, the dielectric material having an outer surface and a corresponding circumference. In an example embodiment, the transmission medium **1525** operates as a single-wire transmission line to guide the transmission of an electromagnetic wave. When the transmission medium **1525** is implemented as a single wire transmission system, it can include a wire. The wire can be insulated or uninsulated, and single-stranded or multi-stranded (e.g., braided). In other embodiments, the transmission medium **1525** can contain conductors of other shapes or configurations including wire bundles, cables, rods, rails, pipes. In addition, the transmission medium **1525** can include non-conductors such as dielectric pipes, rods, rails, or other dielectric members; combinations of conductors and dielectric materials or other guided-wave transmission media. It should be noted that the transmission medium **1525** can otherwise include any of the transmission media previously discussed in conjunction with FIGS. 1-14.

According to an example embodiment, the guided waves **1520** and **1522** can be contrasted with radio transmissions over free space/air or conventional propagation of electrical power or signals through the conductor of a wire. In particular, guided waves **1520** and **1522** are surface waves and other electromagnetic waves that surround all or part of the surface of the transmission medium and propagate with low loss along the transmission medium from transmission device **1500** to transmission device **1502**, and vice versa. The guided waves **1520** and **1522** can have a field structure (e.g., an electromagnetic field structure) that lies primarily or substantially outside of the transmission medium **1525**. In addition to the propagation of guided waves **1520** and **1522**, the transmission medium **1525** may optionally contain one or more wires that propagate electrical power or other communication signals in a conventional manner as a part of one or more electrical circuits.

Turning now to FIG. 16, a block diagram is shown illustrating an example, non-limiting embodiment of a transmission device **1500** or **1502**. The transmission device **1500** or **1502** includes a communications interface (I/F) **1600**, a transceiver **1610** and a coupler **1620**.

In an example of operation, the communications interface **1600** receives a communication signal **1510** or **1512** that

includes first data. In various embodiments, the communications interface **1600** can include a wireless interface for receiving a wireless communication signal in accordance with a wireless standard protocol such as LTE or other cellular voice and data protocol, WiFi or an 802.11 protocol, WIMAX protocol, Ultra Wideband protocol, Bluetooth protocol, Zigbee protocol, a direct broadcast satellite (DBS) or other satellite communication protocol or other wireless protocol. In addition or in the alternative, the communications interface **1600** includes a wired interface that operates in accordance with an Ethernet protocol, universal serial bus (USB) protocol, a data over cable service interface specification (DOCSIS) protocol, a digital subscriber line (DSL) protocol, a Firewire (IEEE 1394) protocol, or other wired protocol. In addition to standards-based protocols, the communications interface **1600** can operate in conjunction with other wired or wireless protocol. In addition, the communications interface **1600** can optionally operate in conjunction with a protocol stack that includes multiple protocol layers.

In an example of operation, the transceiver **1610** generates a first electromagnetic wave based on the communication signal **1510** or **1512** to convey the first data. The first electromagnetic wave has at least one carrier frequency and at least one corresponding wavelength. In various embodiments, the transceiver **1610** is a microwave transceiver that operates at a carrier frequency with a corresponding wavelength that is less than the circumference of (or in an alternative embodiment, the diameter or width of) the transmission medium **1525**. The carrier frequency can be within a millimeter-wave frequency band of 30 GHz-300 GHz or a lower frequency band of 3 GHz-30 GHz in the microwave frequency band, but it will be appreciated that other carrier frequencies are possible in other embodiments. In one mode of operation, the transceiver **1610** merely upconverts the communications signal or signals **1510** or **1512** for transmission of the first electromagnetic signal in the microwave or millimeter-wave band. In another mode of operation, the communications interface **1600** either converts the communication signal **1510** or **1512** to a baseband or near baseband signal or extracts the first data from the communication signal **1510** or **1512** and the transceiver **1610** modulates the first data, the baseband or near baseband signal for transmission.

In an example of operation, the coupler **1620** couples the first electromagnetic wave to the transmission medium **1525**. The coupler **1620** can be implemented via a dielectric waveguide coupler or any of the couplers and coupling devices described in conjunction with FIGS. 1-14. In an example embodiment, the transmission medium **1525** includes a wire or other inner element surrounded by a dielectric material having an outer surface. The dielectric material can include an insulating jacket, a dielectric coating or other dielectric on the outer surface of the transmission medium **1525**. The inner portion can include a dielectric or other insulator, a conductor, air or other gas or void, or one or more conductors.

In an example of operation, the coupling of the first electromagnetic wave to the transmission medium **1525** forms a second electromagnetic wave that is guided to propagate along the outer surface of the dielectric material of the transmission medium via at least one guided-wave mode that includes an asymmetric mode and optionally one or more other modes including a fundamental (symmetric) mode or other asymmetric (non-fundamental) mode. The outer surface of the dielectric material can be the outer surface of an insulating jacket, dielectric coating, or other

dielectric. In an example embodiment, the first electromagnetic wave generated by the transceiver **1610** is guided to propagate along the coupler via at least one guided-wave mode that includes a symmetric mode and wherein a junction between the coupler and the transmission medium induces the asymmetric mode of the second electromagnetic wave and optionally a symmetric mode of the second electromagnetic wave.

In an example embodiment, the transmission medium **1525** is a single wire transmission medium having an outer surface and a corresponding circumference and the coupler **1620** couples the first electromagnetic wave to the single wire transmission medium. In particular, the coupling of the first electromagnetic wave to the single wire transmission medium forms a second electromagnetic wave that is guided to propagate along the outer surface of the single wire transmission medium via at least one guided-wave mode that includes at least one asymmetric mode and optionally a symmetric mode and other asymmetric modes, wherein the at least one carrier frequency in within a microwave or millimeter-wave frequency band and wherein the at least one corresponding wavelength is less than the circumference of the single wire transmission medium. In one mode of operation, the first electromagnetic wave is guided to propagate along the coupler via at least one guided-wave mode that includes a symmetric mode and a junction between the coupler and the transmission medium induces both the asymmetric mode of the second electromagnetic wave and, when present, the symmetric mode of the second electromagnetic wave.

While the prior description has focused on the operation of the transceiver **1610** as a transmitter, the transceiver **1610** can also operate to receive electromagnetic waves that convey second data from the single wire transmission medium via the coupler **1620** and to generate communications signals **1510** or **1512**, via communications interface **1600** that includes the second data. Consider embodiments where a third electromagnetic wave conveys second data that also propagates along the outer surface of the dielectric material of the transmission medium **1525**. The coupler **1620** also couples the third electromagnetic wave from the transmission medium **1525** to form a fourth electromagnetic wave. The transceiver **1610** receives the fourth electromagnetic wave and generates a second communication signal that includes the second data. The communication interface **1600** sends the second communication signal to a communication network or a communications device.

Turning now to FIG. **17**, a diagram is shown illustrating an example, non-limiting embodiment of an electromagnetic field distribution. In this embodiment, a transmission medium **1525** in air includes an inner conductor **1700** and an insulating jacket **1702** of dielectric material, is shown in cross section. The diagram includes different gray-scales that represent differing electromagnetic field strengths generated by the propagation of the guided-wave having an asymmetric mode. The guided-wave has a field structure that lies primarily or substantially outside of the transmission medium **1525** that serves to guide the wave. The regions inside the conductor **1700** have little or no field. Likewise regions inside the insulating jacket **1702** have low field strength. The majority of the electromagnetic field strength is distributed in the lobes **1704** at the outer surface of the insulating jacket **1702** and in close proximity thereof. The presence of an asymmetric guided-wave mode is shown by the high electromagnetic field strengths at the top and

bottom of the outer surface of the insulating jacket **1702**—as opposed to very small field strengths on the other sides of the insulating jacket **1702**.

The example shown corresponds to a 38 GHz wave guided by a wire with a diameter of 1.1 cm and a dielectric insulation of thickness of 0.36 cm. Because the electromagnetic wave is guided by the transmission medium **1525** and the majority of the field strength is concentrated in the air outside of the insulating jacket **1702** within a limited distance of the outer surface, the guided-wave can propagate longitudinally down the transmission medium **1525** with very low loss. In the example shown, this “limited distance” corresponds to a distance from the outer surface that is less than half the largest cross sectional dimension of the transmission medium **1525**. In this case, the largest cross sectional dimension of the wire corresponds to the overall diameter of 1.82 cm, however other this value can vary with the size and shape of the transmission medium **1525**. For example, should the transmission medium be of rectangular shape with a height of 0.3 cm and a width of 0.4 cm, the largest cross sectional dimension would be the diagonal of 0.5 cm and the corresponding limited distance would be 0.25 cm.

In an example embodiment, this particular asymmetric mode of propagation is induced on the transmission medium **1525** by an electromagnetic wave having a frequency that falls within a limited range (such as F_c to $F_c+25\%$) of the lower cut-off frequency F_c of the asymmetric mode, i.e. the lowest frequency that a particular asymmetric or fundamental mode can be supported. For embodiments as shown that include an inner conductor **1700** surrounded by a insulating jacket **1702**, this cutoff frequency can vary based on the dimensions and properties of the insulating jacket **1702** and potentially the dimensions and properties of the inner conductor **1700** and can be determined experimentally to have a desired mode pattern. It should be noted however, that similar effects can be found for a hollow dielectric or insulator without an inner conductor. In this case, the cutoff frequency can vary based on the dimensions and properties of the hollow dielectric or insulator.

At frequencies lower than the lower cut-off frequency, the asymmetric mode is difficult to induce in the transmission medium **1525** and fails to propagate for all but trivial distances. As the frequency increases above the limited range of frequencies about the cut-off frequency, the asymmetric mode shifts more and more inward of the insulating jacket **1702**. At frequencies much larger than the cut-off frequency, the field strength is no longer concentrated outside of the insulating jacket, but primarily inside of the insulating jacket **1702**. While the transmission medium **1525** provides strong guidance to the electromagnetic wave and propagation is still possible, ranges are more limited by increased losses due to propagation within the insulating jacket **1702**—as opposed to the surrounding air.

Turning now to FIG. **18**, a diagram is shown illustrating an example, non-limiting embodiment of various electromagnetic field distributions. In particular, a cross section diagram **1800**, similar to FIG. **17** is shown with common reference numerals used to refer to similar elements. The example shown in cross section **1800** corresponds to a 60 GHz wave guided by a wire with a diameter of 1.1 cm and a dielectric insulation of thickness of 0.36 cm. Because the frequency of the wave is above the limited range of the cut-off frequency, the asymmetric mode has shifted inward of the insulating jacket **1702**. In particular, the field strength is concentrated primarily inside of the insulating jacket **1702**. While the transmission medium **1525** provides strong

guidance to the electromagnetic wave and propagation is still possible, ranges are more limited when compared with the embodiment of FIG. 17, by increased losses due to propagation within the insulating jacket 1702.

The diagrams 1802, 1804, 1806 and 1808 also present 5
embodiments of a transmission medium 1525 in air that includes an inner conductor and an insulating jacket of dielectric material, similar to diagram 1800, but shown in longitudinal cross section and in smaller scale. These diagrams include different gray-scales that represent differing 10
electromagnetic field strengths generated by the propagation of the guided-wave having an asymmetric mode at different frequencies.

At frequencies lower than the lower cut-off frequency, represented by diagram 1808, the electric field is not tightly 15
coupled to the surface of the transmission medium 1525. The asymmetric mode is difficult to induce in the transmission medium 1525 and fails to propagate for all but trivial distances along the transmission medium. At frequencies within the limited range of the cutoff frequency, represented 20
by diagram 1806, while some of the electric field strength is within the insulating jacket, the guided-wave has a field structure that lies primarily or substantially outside of the insulating jacket and outside of the transmission medium 1525 that serves to guide the wave. As discussed in con- 25
junction with FIG. 17, the regions inside the conductor 1700 have little or no field and propagation is supported over reasonable distance and with lower propagation losses, when compared with other frequency ranges. As the frequency increases above the limited range of frequencies 30
about the cut-off frequency, represented by diagram 1804, the asymmetric mode shifts more and more inward of the insulating jacket of transmission medium 1525 increasing propagation losses and reducing effective travel distances. At frequencies much larger than the cut-off frequency, 35
represented by diagram 1802, the field strength is no longer concentrated outside of the insulating jacket, but primarily inside of the insulating jacket 1702. While the transmission medium 1525 provides strong guidance to the electromagnetic wave and propagation is still possible, ranges are more 40
limited by increased losses due to propagation within the insulating jacket 1702—as opposed to the surrounding air.

Turning now to FIG. 19, a block diagram is shown illustrating an example, non-limiting embodiment of a trans- 45
mission device. In particular, a diagram similar to FIG. 16 is presented with common reference numerals used to refer to similar elements. The transmission device 1500 or 1502 includes a communications interface 1600 that receives a communication signal 1510 or 1512 that includes data. The transceiver 1610 generates a first electromagnetic wave 50
based on the communication signal 1510 or 1512 to convey the first data, the first electromagnetic wave having at least one carrier frequency. A coupler 1620 couples the first electromagnetic wave to the transmission medium 1525 having at least one inner portion surrounded by a dielectric 55
material, the dielectric material having an outer surface and a corresponding circumference. The first electromagnetic wave is coupled to the transmission medium to form a second electromagnetic wave that is guided to propagate along the outer surface of the dielectric material via at least 60
one guided-wave mode. The at least one guided-wave mode includes an asymmetric mode having a lower cutoff frequency and the at least one carrier frequency is selected to be within a limited range of the lower cutoff frequency.

The transmission device 1500 or 1502 includes an 65
optional training controller 1900. In an example embodiment, the training controller 1900 is implemented by a

standalone processor or a processor that is shared with one or more other components of the transmission device 1500 or 1502. The training controller 1900 selects the at least one carrier frequency to be within the limited range of the lower cutoff frequency based on feedback data received by the transceiver 1610 from at least one remote transmission device coupled to receive the second electromagnetic wave.

In an example embodiment, a third electromagnetic wave transmitted by a remote transmission device 1500 or 1502 10
conveys second data that also propagates along the outer surface of the dielectric material of a transmission medium 1525. The second data can be generated to include the feedback data. In operation, the coupler 1620 also couples the third electromagnetic wave from the transmission 15
medium 1525 to form a fourth electromagnetic wave and the transceiver receives the fourth electromagnetic wave and processes the fourth electromagnetic wave to extract the second data.

In an example embodiment, the training controller 1900 20
operates based on the feedback data to evaluate a plurality of candidate frequencies and to select the at least one carrier frequency to be within the limited range of the lower cutoff frequency, as one of the plurality of candidate frequencies. For example, the candidate frequencies can be selected 25
based on criteria such as: being in a microwave or millimeter-wave frequency band, having wavelengths greater than an outer circumference of the transmission medium 1525, being less than the mean collision frequency of electrons in a conductor that makes up a portion of the transmission medium 1525, based on experimental results that indicate 30
the limited range of frequencies about the cutoff frequency for a particular transmission medium 1525 and a selected asymmetric mode, and/or based on experimental results or simulations.

Consider the following example: a transmission device 35
1500 begins operation under control of the training controller 1900 by sending a plurality of guided-waves as test signals such as ones or pilot waves at a corresponding plurality of candidate frequencies directed to a remote 40
transmission device 1502 coupled to the transmission medium 1525. A transmission device 1500 can generate first electromagnetic waves that are coupled onto the transmission medium as second electromagnetic waves. While the guided wave modes may differ, generally the carrier frequency or frequencies of the second electromagnetic waves 45
are equal to the carrier frequency or frequencies of the first electromagnetic waves. In cases, however, where the coupling includes a nonlinearity due to a junction, a nonlinear element of a coupler, or other non-linearity, the carrier frequencies of one or more guided wave modes of the 50
second electromagnetic waves can be at a harmonic frequency or frequencies, at the sum of two or more carrier frequencies, or at a difference of two or more carrier frequencies. In either case, the carrier frequency or frequen- 55
cies of the electromagnetic waves launched on a transmission medium can be selected, based on knowledge of the linear or nonlinear effects of the coupling and further based on the selection of the carrier frequency or frequencies of the waves that are coupled to launch the waves on the trans- 60
mission medium.

The guided-waves can include, in addition or in the 65
alternative, test data at a corresponding plurality of candidate frequencies directed to a remote transmission device 1502 coupled to the transmission medium 1525. The test data can indicate the particular candidate frequency of the signal. In an embodiment, the training controller 1900 at the remote transmission device 1502 receives the test signals

and/or test data from any of the guided-waves that were properly received and determines the best candidate frequency, a set of acceptable candidate frequencies, or a rank ordering of candidate frequencies. This candidate frequency or frequencies is generated by the training controller **1900** based on one or more optimizing criteria such as received signal strength, bit error rate, packet error rate, signal to noise ratio, a carrier frequency with reduced or lowest propagation loss, a carrier frequency that is detected, based on an analysis of any of the previous criteria, to be within a limited range of cutoff of a non-fundamental mode or other optimizing criteria can be generated by the transceiver **1610** of the remote transmission device **1502**. The training controller **1900** generates feedback data that indicates the candidate frequency or frequencies and sends the feedback data to the transceiver **1610** for transmission to the transmission device **1500**. The transmission device **1500** and **1502** can then communicate data with one another utilizing the indicated carrier frequency or frequencies.

In other embodiments, the electromagnetic waves that contain the test signals and/or test data are reflected back, repeated back or otherwise looped back by the remote transmission device **1502** to the transmission device **1502** for reception and analysis by the training controller **1900** of the transmission device **1502** that initiated these waves. For example, the transmission device **1502** can send a signal to the remote transmission device **1502** to initiate a test mode where a physical reflector is switched on the line, a termination impedance is changed to cause reflections, a loop back circuits is switched on to couple electromagnetic waves back to the source transmission device **1502**, and/or a repeater mode is enabled to amplify and retransmit the electromagnetic waves back to the source transmission device **1502**. The training controller **1900** at the source transmission device **1502** receives the test signals and/or test data from any of the guided-waves that were properly received and determines the best candidate frequency, a set of acceptable candidate frequencies, or a rank ordering of candidate frequencies. This candidate frequency or frequencies is generated by the training controller **1900** based on one or more optimizing criteria such as received signal strength, bit error rate, packet error rate, signal to noise ratio or other optimizing criteria can be generated by the transceiver **1610** of the remote transmission device **1502**.

While the procedure above has been described in a start-up or initialization mode of operation, each transmission device **1500** or **1502** can send test signals or otherwise evaluate candidate frequencies at other times as well. In an example embodiment, the communication protocol between the transmission devices **1500** and **1502** can include a periodic test mode where either full testing or more limited testing of a subset of candidate frequencies are tested and evaluated. In other modes of operation, the re-entry into such a test mode can be triggered by a degradation of performance due to a disturbance, weather conditions, etc. In an example embodiment, the receiver bandwidth of the transceiver **1610** is either sufficiently wide to include all candidate frequencies or can be selectively adjusted by the training controller **1900** to a training mode where the receiver bandwidth of the transceiver **1610** is sufficiently wide to include all candidate frequencies.

While the guided-wave above has been described as propagating on the outer surface of an outer dielectric surface of the transmission medium **1525**, other outer surfaces of a transmission medium **1525** including the outer surface of a bare wire could likewise be employed. Further, while the training controller **1900** has been described above

as selecting a candidate frequency to be within a limited range of the lower cut-off frequency of an asymmetric mode, the training controller **1900** could be used to establish a candidate frequency that optimizes, substantially optimizes or pareto optimizes the propagation along a transmission medium **1525** based on one or more performance criteria such as throughput, packet error rate, signal strength, signal to noise ratio, signal to noise and interference ratio, channel separation in a multi-channel system, and/or other performance criteria—with or without an asymmetric mode and with or without regard to whether the candidate frequency falls within a limited range of the lower cutoff frequency of any particular mode.

Turning now to FIG. **20**, a flow diagram is shown illustrating an example, non-limiting embodiment of a method of transmission **2000**. The method can be used in conjunction with one or more functions and features described in conjunction with FIGS. **1-19**. Step **2002** includes generating a first electromagnetic wave based on a communication signal to convey data, the first electromagnetic wave having at least one carrier frequency and at least one corresponding wavelength. Step **2004** includes coupling, by a coupler, the first electromagnetic wave to a single wire transmission medium having an outer dielectric surface and a corresponding circumference, wherein the coupling of the first electromagnetic wave to the single wire transmission medium forms a second electromagnetic wave that is guided to propagate along the outer dielectric surface of the single wire transmission medium via at least one guided-wave mode, wherein the carrier frequency or frequencies is/are within a microwave or millimeter-wave frequency band and having a corresponding wavelength or wavelengths less than the circumference of the single wire transmission medium.

In an example embodiment, the at least one guided-wave mode of the second electromagnetic wave includes an asymmetric mode and a symmetric mode. The method can further include guiding the first electromagnetic wave to propagate along the coupler via at least one guided-wave mode that includes a symmetric mode and a junction between the coupler and the transmission medium can induce both the asymmetric mode of the second electromagnetic wave and the symmetric mode of the second electromagnetic wave.

In an example embodiment, the single wire transmission medium includes a wire having a mean collision frequency of electrons and wherein the at least one carrier frequency is less than the mean collision frequency of electrons. The single wire transmission medium can include a wire surrounded by an insulating jacket and the outer dielectric surface of the single wire transmission medium can correspond to the outer surface of the insulating jacket. The single wire transmission medium can include a wire surrounded by a dielectric material and the outer dielectric surface of the single wire transmission medium can correspond to the outer surface of the dielectric material.

Turning now to FIG. **21**, a flow diagram is shown illustrating an example, non-limiting embodiment of a method of transmission **2100**. The method can be used in conjunction with one or more functions and features described in conjunction with FIGS. **1-20**. Step **2102** includes generating a first electromagnetic wave based on a communication signal to convey data, the first electromagnetic wave having at least one carrier frequency. Step **2104** includes coupling, by a coupler, the first electromagnetic wave to a single wire transmission medium having an outer surface, wherein the coupling of the first electromagnetic wave to the single wire transmission medium forms a second electromagnetic wave

that is guided to propagate along the outer surface of the single wire transmission medium via at least one guided-wave mode that includes an asymmetric mode having a lower cutoff frequency, and wherein the at least one carrier frequency is selected to be within a limited range of the lower cutoff frequency.

In an example embodiment, the single wire transmission medium includes a wire surrounded by a dielectric material and wherein the outer surface of the single wire transmission medium corresponds to the outer surface of the dielectric material.

Turning now to FIG. 22, a flow diagram is shown illustrating an example, non-limiting embodiment of a method of selecting a carrier **2200**. The method can be used in conjunction with one or more functions and features described in conjunction with FIGS. 1-21. Step **2202** includes receiving feedback data received from at least one remote transmission device coupled to receive the second electromagnetic wave. Step **2204** includes selecting the at least one carrier frequency to be within the limited range of the lower cutoff frequency based on the feedback data.

In an example embodiment, a third electromagnetic wave conveys second data that also propagates along the outer surface of the dielectric material of the transmission medium. The second data includes the feedback data. The coupler also couples the third electromagnetic wave from the transmission medium and the method further includes receiving the fourth electromagnetic wave and processing the fourth electromagnetic wave to extract the second data.

Turning now to FIG. 23, a flow diagram is shown illustrating an example, non-limiting embodiment of a method of selecting a carrier frequency **2300**. The method can be used in conjunction with one or more functions and features described in conjunction with FIGS. 1-21, and is particularly suited for performing step **2202** described in FIG. 22. Step **2302** includes evaluating a plurality of candidate frequencies. Step **2304** includes selecting the at least one carrier frequency to be within the limited range of the lower cutoff frequency based on feedback data as one of the plurality of candidate frequencies. The plurality of candidate frequencies can be within a microwave or millimeter-wave frequency band.

As used herein, terms such as “data storage,” “database,” and substantially any other information storage component relevant to operation and functionality of a component, refer to “memory components,” or entities embodied in a “memory” or components comprising the memory. It will be appreciated that the memory components or computer-readable storage media, described herein can be either volatile memory or nonvolatile memory or can include both volatile and nonvolatile memory.

As used herein, the term “millimeter-wave” refers to electromagnetic waves that fall within the “millimeter-wave frequency band” of 30 GHz to 300 GHz. The term “microwave” refers to electromagnetic waves that fall within the “microwave frequency band” of 300 MHz to 300 GHz.

In addition, a flow diagram may include a “start” and/or “continue” indication. The “start” and “continue” indications reflect that the steps presented can optionally be incorporated in or otherwise used in conjunction with other routines. In this context, “start” indicates the beginning of the first step presented and may be preceded by other activities not specifically shown. Further, the “continue” indication reflects that the steps presented may be performed multiple times and/or may be succeeded by other activities not specifically shown. Further, while a flow diagram indi-

cates a particular ordering of steps, other orderings are likewise possible provided that the principles of causality are maintained.

As may also be used herein, the term(s) “operably coupled to”, “coupled to”, and/or “coupling” includes direct coupling between items and/or indirect coupling between items via one or more intervening items. Such items and intervening items include, but are not limited to, junctions, communication paths, components, circuit elements, circuits, functional blocks, and/or devices. As an example of indirect coupling, a signal conveyed from a first item to a second item may be modified by one or more intervening items by modifying the form, nature or format of information in a signal, while one or more elements of the information in the signal are nevertheless conveyed in a manner than can be recognized by the second item. In a further example of indirect coupling, an action in a first item can cause a reaction on the second item, as a result of actions and/or reactions in one or more intervening items.

What has been described above includes mere examples of various embodiments. It is, of course, not possible to describe every conceivable combination of components or methodologies for purposes of describing these examples, but one of ordinary skill in the art can recognize that many further combinations and permutations of the present embodiments are possible. Accordingly, the embodiments disclosed and/or claimed herein are intended to embrace all such alterations, modifications and variations that fall within the spirit and scope of the appended claims. Furthermore, to the extent that the term “includes” is used in either the detailed description or the claims, such term is intended to be inclusive in a manner similar to the term “comprising” as “comprising” is interpreted when employed as a transitional word in a claim.

What is claimed is:

1. A transmission device comprising:

a transceiver that generates a first electromagnetic wave conveying first data, the first electromagnetic wave having a carrier frequency and a corresponding wavelength;

a coupler, coupled to the transceiver, that couples the first electromagnetic wave to a transmission medium having at least one inner portion surrounded by a dielectric material, the dielectric material having an outer surface and a corresponding circumference, wherein the coupling of the first electromagnetic wave to the transmission medium results in a second electromagnetic wave that is guided to propagate along the outer surface of the dielectric material via at least one guided-wave mode that includes a non-fundamental mode, wherein the carrier frequency is within a microwave frequency band and wherein the corresponding wavelength is less than the circumference of the dielectric material.

2. The transmission device of claim 1, wherein the at least one guided-wave mode of the second electromagnetic wave further includes a fundamental mode.

3. The transmission device of claim 2, wherein the first electromagnetic wave is guided to propagate along the coupler via at least one guided-wave mode that includes a fundamental mode and wherein a junction between the coupler and the transmission medium induces both the non-fundamental mode of the second electromagnetic wave and the fundamental mode of the second electromagnetic wave.

4. The transmission device of claim 1, wherein the first electromagnetic wave is guided to propagate along the coupler via at least one guided-wave mode that includes a

fundamental mode and wherein a junction between the coupler and the transmission medium induces the non-fundamental mode of the second electromagnetic wave.

5. The transmission device of claim 1, wherein the at least one inner portion includes a conductor having a mean collision frequency of electrons and wherein the carrier frequency is less than the mean collision frequency of electrons.

6. The transmission device of claim 1, wherein the dielectric material includes an insulating jacket and wherein the outer surface of the dielectric material corresponds to an outer surface of the insulating jacket.

7. The transmission device of claim 1, wherein a third electromagnetic wave conveys second data that also propagates along the outer surface of the dielectric material of the transmission medium;

wherein the coupler also couples the third electromagnetic wave from the transmission medium to form a fourth electromagnetic wave; and

wherein the transceiver receives the fourth electromagnetic wave and generates a communication signal that includes the second data.

8. A transmission device comprising:

means for generating a first electromagnetic wave, the first electromagnetic wave having a carrier frequency and a corresponding wavelength;

means for coupling the first electromagnetic wave to a single wire transmission medium having an outer surface and a corresponding circumference, wherein the coupling of the first electromagnetic wave to the single wire transmission medium results in a second electromagnetic wave that is guided to propagate along the outer surface of the single wire transmission medium via at least one guided-wave mode that includes an asymmetric mode, wherein the carrier frequency is within a non-optical frequency band and wherein the corresponding wavelength is less than the corresponding circumference of the single wire transmission medium.

9. The transmission device of claim 8, wherein the at least one guided-wave mode of the second electromagnetic wave further includes a symmetric mode.

10. The transmission device of claim 9, wherein the means for coupling includes a coupler, wherein the first electromagnetic wave is guided to propagate along the coupler via at least one guided-wave mode that includes a symmetric mode and wherein a junction between the coupler and the single wire transmission medium induces both the asymmetric mode of the second electromagnetic wave and the symmetric mode of the second electromagnetic wave.

11. The transmission device of claim 8, wherein the means for coupling includes a coupler, wherein the first electromagnetic wave is guided to propagate along the coupler via at least one guided-wave mode that includes a symmetric mode and wherein a junction between the coupler and the single wire transmission medium induces the asymmetric mode of the second electromagnetic wave.

12. The transmission device of claim 8, wherein the single wire transmission medium includes a wire having a mean

collision frequency of electrons and wherein the carrier frequency is less than the mean collision frequency of electrons.

13. The transmission device of claim 8, wherein the single wire transmission medium includes a wire surrounded by an insulating jacket and wherein the outer surface of the single wire transmission medium corresponds to an outer surface of the insulating jacket.

14. The transmission device of claim 8, wherein the single wire transmission medium includes a wire surrounded by a dielectric material and wherein the outer surface of the single wire transmission medium corresponds to an outer surface of the dielectric material.

15. A method comprising:

generating a first electromagnetic wave, the first electromagnetic wave having a carrier frequency and a corresponding wavelength; and

coupling the first electromagnetic wave to a single wire transmission medium having an outer dielectric surface and a corresponding circumference, wherein the coupling of the first electromagnetic wave to the single wire transmission medium results in a second electromagnetic wave that is guided to propagate along the outer dielectric surface of the single wire transmission medium via at least one guided-wave mode, wherein the carrier frequency is within a millimeter-wave frequency band and wherein the corresponding wavelength is less than the corresponding circumference of the single wire transmission medium.

16. The method of claim 15, wherein the single wire transmission medium has a substantially circular cross section and the at least one guided-wave mode of the second electromagnetic wave includes an asymmetric mode and a symmetric mode.

17. The method of claim 16, further comprising:

guiding the first electromagnetic wave to propagate along a coupler via at least one guided-wave mode that includes a symmetric mode and wherein a junction between the coupler and the single wire transmission medium induces both the asymmetric mode of the second electromagnetic wave and the symmetric mode of the second electromagnetic wave.

18. The method of claim 15, wherein the single wire transmission medium includes a conductive wire having a mean collision frequency of electrons and wherein the carrier frequency is less than the mean collision frequency of electrons.

19. The method of claim 15, wherein the single wire transmission medium includes a wire surrounded by an insulating jacket and wherein the outer dielectric surface of the single wire transmission medium corresponds to an outer surface of the insulating jacket.

20. The method of claim 15, wherein the single wire transmission medium includes a wire surrounded by a dielectric material and wherein the outer dielectric surface of the single wire transmission medium corresponds to an outer surface of the dielectric material.

* * * * *