

M255XK

**5¼" Mini-Flexible Disk Drive  
Customer Engineering Manual**

COPY



**FUJITSU**





REVISION RECORD		
Edition	Date Published	Revised Contents
01	April 1987	Initial Fujitsu America Release

Direct your comments on this publication to:

**FUJITSU AMERICA, INC.**  
**3055 Orchard Drive**  
**San Jose, CA 95134 USA**  
**TEL: (408) 432-1300**  
**FAX: (408) 432-1318**  
**TLX: 230-176207**  
**TWX: (910) 338-2193**

The contents of this manual are subject to change without prior notice.

Copyright 1987 FUJITSU AMERICA, INC.  
 All Rights Reserved

**LIST OF PAGES WITH REVISION LEVEL**

Page	Rev	Page	Rev	Page	Rev	Page	Rev	Page	Rev
Cover	01	4-1	01	5-1	01				
i	01	4-2	01	5-2	01				
ii	01	4-3	01	5-3	01				
iii	01	4-4	01	5-4	01				
iv	01	4-5	01	5-5	01				
v	01	4-6	01	5-6	01				
vi	01	4-7	01	5-7	01				
vii	01	4-8	01	5-8	01				
		4-9	01	5-9	01				
1-1	01	4-10	01	5-10	01				
1-2	01	4-11	01	5-11	01				
1-3	01	4-12	01	5-12	01				
2-1	01	4-13	01	5-13	01				
2-2	01	4-14	01	5-14	01				
2-3	01	4-15	01	5-15	01				
2-4	01	4-16	01	5-16	01				
2-5	01	4-17	01	5-17	01				
2-6	01	4-18	01	5-18	01				
		4-19	01	5-19	01				
3-1	01	4-20	01	5-20	01				
3-2	01	4-21	01	5-21	01				
3-3	01	4-22	01						
3-4	01	4-23	01						
3-5	01	4-24	01						
3-6	01	4-25	01						
3-7	01	4-26	01						
3-8	01	4-27	01						
3-9	01	4-28	01						
3-10	01	4-29	01						
3-11	01	4-30	01						
3-12	01	4-31	01						
3-13	01	4-32	01						
		4-33	01						
		4-34	01						
		4-35	01						
		4-36	01						
		4-37	01						
		4-38	01						
		4-39	01						
		4-40	01						

## TABLE OF CONTENTS

SECTION 1 INTRODUCTION		Page
1.1	Scope . . . . .	1-1
1.2	General Description . . . . .	1-1
1.3	Key Features . . . . .	1-2
1.4	Options and Accessories . . . . .	1-3
SECTION 2 SPECIFICATIONS		
2.1	Physical Dimension . . . . .	2-1
2.2	Storage Capacity . . . . .	2-2
2.3	Disk Mechanism . . . . .	2-2
2.4	Track Access Mechanism . . . . .	2-3
2.5	INDEX Pulse . . . . .	2-3
2.6	Read/Write Head and Track Specifications . . . . .	2-4
2.7	Power Requirements . . . . .	2-4
2.8	Environmental Conditions . . . . .	2-5
2.9	Reliability . . . . .	2-5
2.10	Regulatory Agency Certification . . . . .	2-6
2.11	Write Protect Mechanism . . . . .	2-6
2.12	I/O Signal Interface . . . . .	2-6
SECTION 3 THEORY OF OPERATIONS		
3.1	Construction and Functions . . . . .	3-1
3.1.1	Frame Assembly . . . . .	3-2
3.1.2	Door Opening/Closing and Disk Clamp Mechanism . . . . .	3-2
3.1.3	Spindle Mechanism . . . . .	3-2
3.1.4	Read/Write Head and Carriage . . . . .	3-2
3.1.5	Seek Mechanism . . . . .	3-3
3.1.6	Write Protect Detection . . . . .	3-3
3.1.7	Track 00 Detection . . . . .	3-3
3.1.8	Index Detection . . . . .	3-3
3.1.9	Diskette Inserted Detection . . . . .	3-4
3.1.10	Head Load Mechanism . . . . .	3-4
3.1.11	Door Lock Mechanism . . . . .	3-4
3.2	Circuit Operations . . . . .	3-4
3.2.1	Read/Write Circuits . . . . .	3-4
3.2.2	Control Circuits . . . . .	3-8
3.2.3	Spindle Motor . . . . .	3-10
3.3	Test Points . . . . .	3-11
3.3.1	TP1 and TP2 Pre-Amp . . . . .	3-11
3.3.2	TP3 Ground . . . . .	3-12
3.3.3	TP4 and TP5 Differential Amp . . . . .	3-12
3.3.4	TP6 Erase Gate . . . . .	3-12
3.3.5	TP7 Track 00 Sensor . . . . .	3-13

## TABLE OF CONTENTS

SECTION 4	MAINTENANCE	Page
4.1	Periodic Maintenance . . . . .	4-1
4.1.1	Inspection and Adjustment Items . . . . .	4-1
4.1.2	Field Replaceable Items . . . . .	4-1
4.1.3	Tools Required for Maintenance . . . . .	4-2
4.2	Maintenance Precautions . . . . .	4-3
4.2.1	Screw Torque . . . . .	4-3
4.2.2	Screw Lock . . . . .	4-3
4.2.3	Handling Connectors . . . . .	4-4
4.2.4	Additional Maintenance Precautions . . . . .	4-4
4.3	Head Cleaning . . . . .	4-8
4.4	Inspection and Adjustment Procedures . . . . .	4-9
4.4.1	Collet Assembly Centering Adjustment . . . . .	4-9
4.4.2	Bail Inspection and Adjustment . . . . .	4-10
4.4.3	Disk-in Sensor Inspection . . . . .	4-11
4.4.4	Write Protect Sensor . . . . .	4-12
4.4.5	Disk Rotational Speed . . . . .	4-13
4.4.6	Head Contact Inspection and Adjustment . . . . .	4-13
4.4.7	Asymmetry . . . . .	4-15
4.4.8	Read Level . . . . .	4-16
4.4.9	Resolution . . . . .	4-17
4.4.10	Track Alignment . . . . .	4-18
4.4.11	Track 00 Sensor Inspection and Adjustment . . . . .	4-20
4.4.12	Index Burst Timing Inspection and Adjustment . . . . .	4-22
4.4.13	Head Load Inspection and Adjustment . . . . .	4-24
4.4.14	Door Lock Inspection . . . . .	4-26
4.5	Removal and Replacement Procedures . . . . .	4-27
4.5.1	Head Carriage Replacement . . . . .	4-27
4.5.2	Stepping Motor and Steel Band Replacement . . . . .	4-31
4.5.3	Spindle Motor Replacement . . . . .	4-32
4.5.4	Collet Assembly Replacement . . . . .	4-33
4.5.5	Sensor Block Replacement . . . . .	4-33
4.5.6	Main Circuit Card Replacement . . . . .	4-34
4.5.7	Write Protect Sensor Replacement . . . . .	4-35
4.5.8	Bezel Replacement . . . . .	4-35
4.5.9	Front Lever Replacement . . . . .	4-35
4.5.10	Clamp Cam Replacement . . . . .	4-36
4.5.11	Head Load Replacement . . . . .	4-37
4.5.12	Door Lock Solenoid Replacement . . . . .	4-38
<b>SECTION 5</b>		
<b>MAINTENANCE DRAWINGS AND PARTS LISTS</b>		
5.1	Construction . . . . .	5-1
5.2	Structural Parts Listing . . . . .	5-7
5.3	Screws and Washers . . . . .	5-9
5.4	Main Circuit Card Components . . . . .	5-10
5-5	Circuit Card Layout and Schematic Diagrams . . . . .	5-14

## LIST OF ILLUSTRATIONS

FIGURE		Page
2-1	External Outline Drawing of Disk Drive . . . . .	2-1
3-1	Overall Block Diagram . . . . .	3-1
3-2	Tunnel Erase Type Read/Write Head . . . . .	3-2
3-3	Read/Write Circuits . . . . .	3-5
3-4	Typical Read Circuit Waveforms . . . . .	3-6
3-5	Typical Write Circuit Waveforms . . . . .	3-7
3-6	Control Circuits . . . . .	3-9
3-7	Typical Stepping Motor Control Circuit Waveforms . . . . .	3-10
3-8	Location of Connectors and Test Points . . . . .	3-11
3-9	TP1/TP2 Typical Pre-Amp Waveform . . . . .	3-12
3-10	TP4/TP5 Typical Differential Amp Waveform . . . . .	3-12
3-11	TP6 Typical Erase Gate Waveform . . . . .	3-12
3-12	TP7 Track 00 Detect Waveform . . . . .	3-13
4-1A	M2553K/54K Revision 2 Circuit Card - Jumper Locations . . . . .	4-4
4-1B	M2553K Revision 3 Circuit Card - Jumper Locations . . . . .	4-6
4-1C	M2552K Revision 1 Circuit Card - Jumper Locations . . . . .	4-7
4-2	Disk Drive Orientation During Maintenance . . . . .	4-8
4-3	Collet Shaft Adjustment . . . . .	4-9
4-4	Bail Height Adjustment . . . . .	4-10
4-5	Bail Adjustment . . . . .	4-11
4-6	Write Protect Sensor . . . . .	4-12
4-7	Head Contact Inspection . . . . .	4-14
4-8	Asymmetry Measurement . . . . .	4-15
4-9	Average Read Level Measurement (2F) . . . . .	4-16
4-10	Resolution Measurement . . . . .	4-17
4-11	Lobe Pattern for Track Alignment . . . . .	4-18
4-12	Track Alignment Adjustment . . . . .	4-19
4-13	Track 00 Sensor Adjustment . . . . .	4-21
4-14	Index Burst Timing . . . . .	4-22
4-15	Index Sensor Adjustment . . . . .	4-23
4-16	Head Load Signal "A" . . . . .	4-24
4-17	Head Load Signal "B" . . . . .	4-24
4-18	Head Load Adjustment Screw . . . . .	4-25
4-19	Head Unload Signal "A" . . . . .	4-25
4-20	Head Unload Signal "B" . . . . .	4-25
4-21	Door Lock Solenoid Activated . . . . .	4-26
4-22	Door Lock Solenoid Deactivated . . . . .	4-26
4-23	Head Carriage Assembly Replacement . . . . .	4-28
4-24	Head Cable Routing . . . . .	4-29
4-25	Clamp Cam Assembly . . . . .	4-36
4-26	Head Load Height Adjustment . . . . .	4-37
4-27	Door Lock Solenoid . . . . .	4-38

## LIST OF ILLUSTRATIONS (Continued)

FIGURE	Page
5-1 Top View of Disk Drive (View 1)	5-2
5-2 Top View of Disk Drive (View 2)	5-3
5-3 Bottom View of Disk Drive	5-4
5-4 Rear View of M255XK	5-5
5-5 Exploded View Drawing	5-6
5-6 M2552K Revision 1 Circuit Card Layout	5-15
5-7 M2553/54K Revision 2 Circuit Card Layout	5-16
5-8 M2553 Revision 3 Circuit Card Layout	5-17
5-9 Interconnect Diagram	5-18
5-10 M2552K Revision 1 Schematic Drawing	5-17
5-9 M2553/54K Revision 2 Schematic Drawing	5-19
5-10 M2553K Revision 3 Schematic Drawing	5-21

## LIST OF TABLES

TABLE	Page
2-1 MFM Recording Storage Capacity	2-2
2-2 Disk Mechanism	2-2
2-3 Track Access Mechanism	2-3
2-4 INDEX Pulse	2-3
2-5 Read/Write Head and Track Specifications	2-4
2-6 Power Supply Requirements	2-4
2-7 Environmental Conditions	2-5
2-8 Reliability	2-5
2-9 Regulatory Agency Certification	2-6
2-10 Interface Signal - Pin Designation	2-6
4-1 Inspection and Adjustment Items	4-1
4-2 Field Replaceable Items	4-2
4-3 Maintenance Tools	4-2
4-4 Screw Size and Torque	4-3
4-5A M2553K/54K Revision 2 Circuit Card Jumper Definitions	4-5
4-5B M2553K Revision 3 Circuit Card Jumper Definitions	4-6
4-5C M2552K Revision 1 Circuit Card Jumper Definitions	4-7
5-1 M255XK Assembly Chart	5-1
5-2 Listing of Structural Parts	5-7
5-3 Listing of Screws and Washers	5-9
5-4 Listing of Main Circuit Card Components	5-10



## SECTION 1 INTRODUCTION

### 1.1 SCOPE

This manual explains the service procedures for the FUJITSU M255XK Family of 5¼" Mini Flexible Disk Drives.

This Section gives an overview of the Disk Drives.

Section 2 provides specifications.

Section 3 explains the drive's operations

Section 4 details maintenance procedures

Section 5 contains parts lists and mechanical and schematic drawings.

### 1.2 GENERAL DESCRIPTION

M255XK disk drives offer superior performance, reliability and construction in Half-Height 5¼" Flexible Disk Drive technology.

Industry standard 5¼" (130mm) diskettes are used as the storage medium. These drives have an independently addressed Read/Write head for each side of the diskette.

FM (Frequency Modulation) or MFM (Modified Frequency Modulation) recording methods are acceptable.

There are three Models in the M255XK Family:

**M2552K** - This model records 5,922 flux transitions per inch and has a per disk unformatted storage capacity of 1 Mbyte with MFM Encoding or 500 Kbytes with FM Encoding.

With a 16 sector format (256 bytes per sector), the M2552K emulates a double density/double sided, 96 track per inch 5¼" industry standard disk drive.

**M2553K** - This model records 9,646 flux transitions per inch and has a per disk unformatted storage capacity of 1.604 Mbytes with MFM Encoding or 802 Kbytes with FM Encoding.

With a 15 sector format (512 bytes per sector) the M2553K emulates a double density/double sided, 96 track per inch (1.2 MByte) industry standard 5¼" disk drive.

**M2554K** - This model has a host system controlled interface line (pin-2) that allows operation at either 300 RPM, or 360 RPM.

#### **M2554K (Continued)**

When set at 300 RPM the M2554K records 5,922 flux transitions per inch (similar to a M2552K) and has a per disk unformatted storage capacity of 1 Mbyte with MFM Encoding or 500 Kbytes with FM Encoding.

When set at 360 RPM, the M2554K records 9646 flux transitions per inch (similar to the M2553K). and has a per disk unformatted storage capacity of 1.604 Mbytes with MFM Encoding or 802 Kbytes with FM Encoding.

With MFM recording methods, the data transfer rate is:

**M2552K** - 250 Kbits per second

**M2553K** - 500 Kbits per second

**M2554K** - 250 Kbits per second at 300 RPM  
- 500 Kbits per second at 360 RPM

Spindle motor speed is:

**M2552K** - 300 RPM

**M2553K** - 360 RPM

**M2554K** - Host system selected (via an interface signal line) for 300 or 360 RPM

On all Models, Track density is 96 TPI and there are 80 cylinders/160 tracks per disk. Track to track access time is 3 milliseconds, plus a 15 millisecond settling time. Average access time, including settling time, is 94 milliseconds.

Except for the differences listed above, performance of the units is identical.

Refer to the M255XK Product Description Manual for an overview of the M2552K, M2553K, and M2554K Mini Flexible Disk Drives.

### **1.3 KEY FEATURES**

- o Half-Height (1.625 inches)
- o Industry standard flexible disk drive mounting
- o Industry standard flexible disk drive interface
- o Vertical clamping mechanism
- o Up to 1.604 Mbytes of unformatted storage capacity
- o The M2554K may be set by the host computer to function as a 1.6 Mbyte or 1.0 Mbyte capacity disk drive (allowing a single source for two products)
- o High quality and reliability
- o FUJITSU AMERICA support

## 1.4 OPTIONS AND ACCESSORIES

- o Automatic Diskette Eject

Ejects the diskettes from the disk drive, when the door lever is released. The disk drive is set to the Not Ready State (when the diskette is ejected).

- o Head Load Solenoid

Allows the host system to Load/Unload the Read/Write heads in the disk drive via an interface signal line.

- o Auto-Rezero

Rotates the diskette (to full speed) and retracts the Read/Write heads to Track 00, whenever power is turned-on.

- o Door Lock

Allows the door lever to be locked, to prevent media removal, when the drive is selected or when In Use is selected.

- o Door Switch

Allows the Ready signal to be active whenever the door is closed regardless of Drive Selection.



## SECTION 2 SPECIFICATIONS

### 2.1 PHYSICAL DIMENSIONS

Refer to the following drawing (Figure 2-1).

Height:	With Bezel	= 1.65 ± 0.02 inches (42 ± 0.5mm)
	Without Bezel	= 1.62 ± 0.02 inches (41 ± 0.5mm)
Width:	With Bezel	= 5.83 ± 0.02 inches (148 ± 0.5mm)
	Without Bezel	= 5.75 ± 0.02 inches (146 ± 0.5mm)
Depth*:	With Bezel	= 8.19 ± 0.02 inches (208 ± 0.5mm)
	Without Bezel	= 8.00 ± 0.02 inches (203 ± 0.5mm)

\* Without power or interface cable connector

Weight: 3.10 pounds (1.2 Kg) maximum

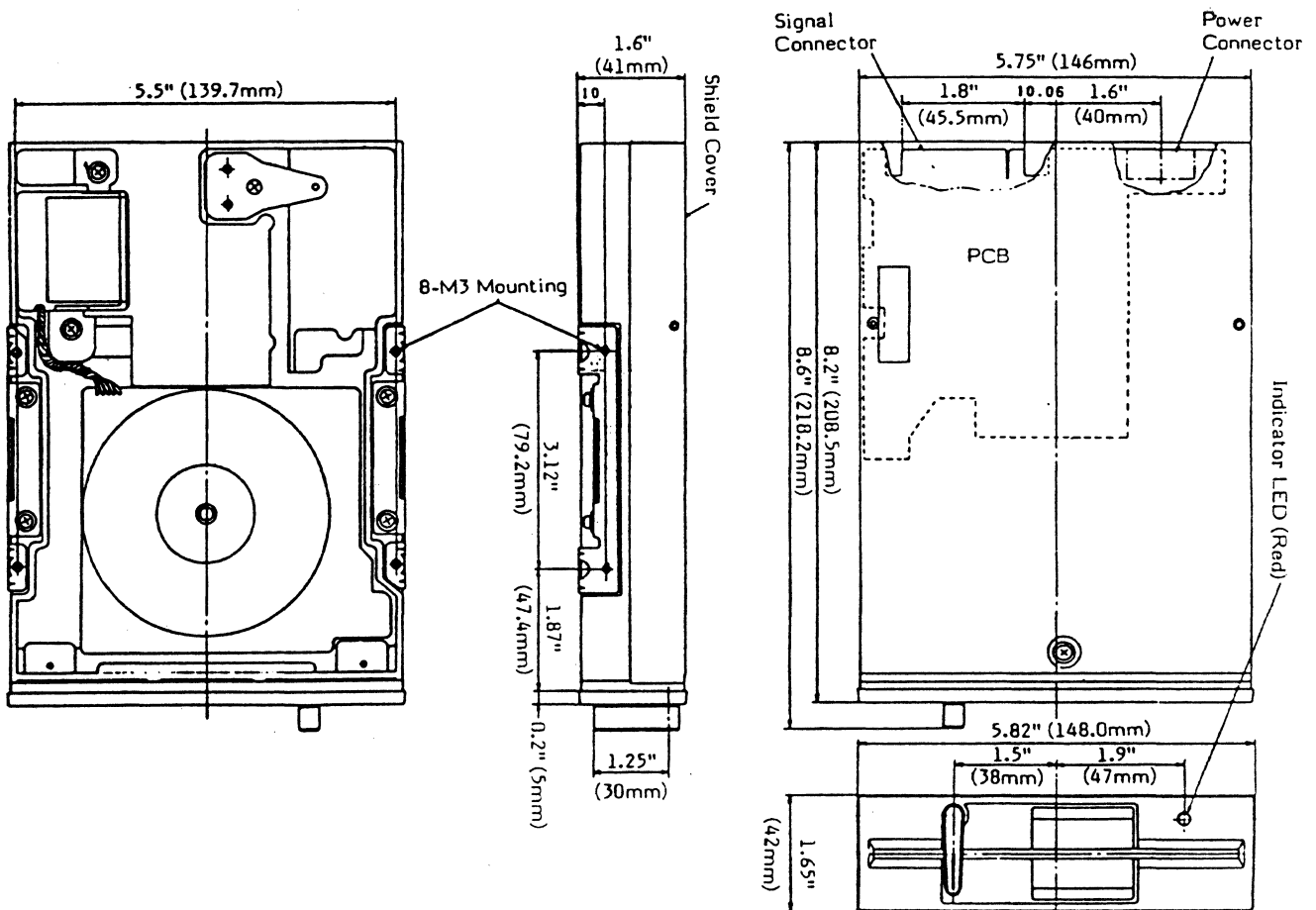

Figure 2-1 External Outline Drawing of Disk Drive

## 2.2 STORAGE CAPACITY

Table 2-1 MFM Recording Storage Capacity*				
MODEL NUMBER	M2552K	M2553K	300 RPM M2554K	360 RPM M2554K
<b>UNFORMATTED:</b> Each Diskette Each Track	1.000MB 6.25KB	1.604MB 10.416KB	1.000MB 6.25KB	1.604MB 10.416KB
<b>16-SECTOR FORMAT</b> Each Diskette Each Track Each Sector	655.36KB 4.096KB 256 Bytes	- - -	655.36KB 4.096KB 256 Bytes	- - -
<b>FORMATTED 15-Sectors</b> Each Diskette Each Track Each Sector	- - -	1.229MB 7.680KB 512 Bytes	- - -	1.229MB 7.680KB 512 Bytes
<b>BITS PER INCH</b>	5922	9646	5922	9646
<b>TRACKS PER INCH</b>	96TPI	96TPI	96TPI	96TPI
<b># OF TRACKS</b>	160	160	160	160
<b># OF CYLINDERS</b>	80	80	80	80
<b>TRANSFER RATE</b>	250KBS	500KBS	250KBS	500KBS

\* = One-half the given Storage Capacity values with FM Encoding.

## 2.3 DISK MECHANISM

Table 2-2 Disk Mechanism				
MODEL NUMBER	M2552K	M2553K	300 RPM M2554K	360 RPM M2554K
<b>SPINDLE SPEED</b>	300 RPM	360 RPM	300 RPM	360 RPM
<b>AVERAGE LATENCY TIME</b>	100 msec	83.3 msec	100 msec	83.3 msec
<b>SPEED VARIATION</b>	± 1.5% Maximum Long Term & Instantaneous			
<b>ROTATIONAL CONTROL</b>	AC Tachometer Controlled Frequency Servo			
<b>SPINDLE MOTOR TYPE</b>	Direct Drive DC Brushless Motor			
<b>SPINDLE START TIME</b>	400 milliseconds maximum			

## 2.4 TRACK ACCESS MECHANISM

Table 2-3 Track Access Mechanism	
STEPS PER TRACK	1 step
ACCESS TIME	
Track to Track (Without settling time)	3 msec
Average (Inner-track) (With settling time)	94 msec
POSITIONING ACCURACY	Within $\pm 20$ micrometers at 96 TPI (Track 32), using a Standard Test Diskette at 74° F (23° C) $\pm 2^\circ$ at 40-60% Relative Humidity
HEAD SETTLING TIME	15 milliseconds maximum, does not include track access time
HEAD CARRIAGE DRIVE	4-Phase Stepper Motor and Steel Belt
TRACK 00 DETECTION	LED and Photo-transistor Detection Mechanical stop on head carriage

## 2.5 INDEX PULSE

Table 2-4 INDEX Pulse	
INDEX DURATION	1 to 8 milliseconds (use the leading edge)
TIME BETWEEN INDEX PULSES	200.00 milliseconds $\pm 1.5\%$ at 300 RPM 166.67 milliseconds $\pm 1.5\%$ at 360 RPM
INDEX ACCURACY	200 $\pm$ 150 microseconds from the beginning of the INDEX hole on a standard test diskette
FIRST INDEX PULSE	400 millisecond nominal after Motor Start
NUMBER OF PULSES	One (1) INDEX Pulse per disk revolution
INDEX DETECTION	LED and Photo-transistor

## 2.6 READ/WRITE HEAD AND TRACK SPECIFICATIONS

Table 2-5 Read/Write Head and Track Specifications	
TYPE OF R/W HEAD	Gimbal supported with Tunnel Erase
NUMBER OF R/W HEADS	Two (one on each side of the Diskette)
R/W HEAD TRACK WIDTH	0.165mm standard 0.155 ± 0.015mm after Tunnel Erase:
ERASE HEAD WIDTH	0.095mm standard
WRITE/READ - ERASE GAP	0.85 ± 0.05mm - M2552K 0.58 ± 0.05mm - M2553K and M2554K
WRITE/READ GAP AZIMUTH Standard Test Diskette	0 ± 26' - M2552K 0 ± 18' - M2553K and M2554K
TRACK RADIUS (Maximum)	
Track 00 (External Lap):	57.150mm Side 0 55.033mm Side 1
Track 79 (Internal Lap):	36.248mm Side 0 34.131mm Side 1

## 2.7 POWER REQUIREMENTS

Table 2-6 Power Supply Requirements	
+12 VOLTS DC	+5% allowable variance during read/write operations and +10% at other times 200 millivolt maximum peak-to-peak ripple voltage (including noise spikes) 0.22 Amperes average current draw 0.60 Amperes maximum average current draw 0.90 Amperes peak current draw (Spindle Motor start-up) 0.07 Amperes maximum current draw (Spindle Motor idle)
+5 VOLTS DC	+5% allowable variance 100 millivolt maximum peak-to-peak ripple voltage (including noise spikes) 0.29 Amperes average current draw 0.33 Amperes maximum current draw (Spindle Motor idle) 0.50 Amperes maximum average current draw (standby mode) 0.60 Amperes maximum average current draw (operating)



## 2.8 ENVIRONMENTAL CONDITIONS

Table 2-7 Environmental Conditions			
	OPERATING	STORAGE	TRANSPORT*
Ambient Temperature Non-condensing	39 to 115° F (4 to 46° C)	-7.6 to 140° F (-22 to 60° C)	-40 to 149° F (-40 to 65° C)
Temperature Gradients (Maximum)	59° F/Hour (15° C/Hour)	Not specified	86° F/Hour (30° C/Hour)
Relative Humidity (Maximum Wet-Bulb) Non-condensing	20 to 80% Max. 84° F (29° C)	10 to 90% Max. 104° F (40° C)	5 to 95% Max. 113° F (45° C)
Vibration Tolerance (Maximum)	0.50G 55Hz 0.25G 55 to 150HZ	Not Specified	2.0G 100Hz
Shock Tolerance (Maximum)	10G 10msec	Not Specified	40G 10msec

\* Packed in designated crates with conditions conforming to JIS-Z0200 - Provisions for Correctly Packed Freight Testing Methods; Level II.

When transport takes place over an extended period (such as trans-oceanic by ship) the Storage Environmental Conditions apply.

## 2.9 RELIABILITY

Table 2-8 Reliability	
MEAN TIME BETWEEN FAILURES (MTBF)	11,000 Power-on hours, with 25% duty cycle
MEAN TIME TO REPAIR (MTTR)	30 Minutes Maximum to subassembly level
PERIODIC MAINTENANCE	Not required. Head Cleaning if necessary
PRODUCT LIFE	5 years
DISK LIFE	Three times 10 <sup>6</sup> passes/track minimum
DISKETTE INSERTIONS	One times 10 <sup>4</sup> insertions minimum
DATA ERROR RATES: Soft Read Error Rate Hard Read Error Rate	One per 10 <sup>9</sup> bits (with up to 2 re-reads) One per 10 <sup>12</sup> bits (with more than 2 re-reads)
SEEK ERROR RATE	One per 10 <sup>6</sup> seeks

## 2.10 REGULATORY AGENCY CERTIFICATION

Table 2-9 Regulatory Agency Certification	
FCC (Federal Communications Commission) See FCC Statement on inside of back cover.	CFD 75U255X
UL (Underwriters Laboratories)	UL E8729-1
CSA (Canadian Standards Association)	LR 60527-1

## 2.11 WRITE PROTECT MECHANISM

Diskette's Write Protect Notch is detected with a Light Emitting Diode (LED) and Photo-transistor.

## 2.12 I/O SIGNAL INTERFACE

Complete I/O control and data interface specifications are given in the M255XA Product Description Manual. Table 2-10 lists the Interface Pin Designations.

Table 2-10 Interface Signal - Pin Designation			
Signal Name	Direction	Signal-Pin Number	Return-Pin Number
HD (Hi Density)/LSP (Speed)*	Out/In	2	1
IN USE/HEAD LOAD	Input	4	3
-DRIVE SELECT 3	Input	6	5
-INDEX PULSE	Output	8	7
-DRIVE SELECT 0	Input	10	9
-DRIVE SELECT 1	Input	12	11
-DRIVE SELECT 2	Input	14	13
-MOTOR-ON	Input	16	15
-DIRECTION SELECT	Input	18	17
-STEP	Input	20	19
-WRITE DATA	Input	22	21
-WRITE GATE	Input	24	23
-TRACK 00	Output	26	25
-WRITE PROTECT	Output	28	27
-READ DATA	Output	30	29
-SIDE ONE SELECT	Input	32	30
-READY/DISK CHANGE	Output	34	33

\* Pin 2 is unused in the M2552K

## SECTION 3 THEORY OF OPERATIONS

### 3.1 CONSTRUCTION AND FUNCTIONS

M255XK drives are constructed with high precision components and assembled with automated techniques. This ensures that the industry standard 5¼" flexible mylar disk, used as the recording medium, has the ability to interchange data with other 5¼" disk drives.

As with all high precision equipment, excessive shock and vibration must be avoided and only trained maintenance personnel should service the unit.

Refer to the Overall Block Diagram in Figure 3-1.

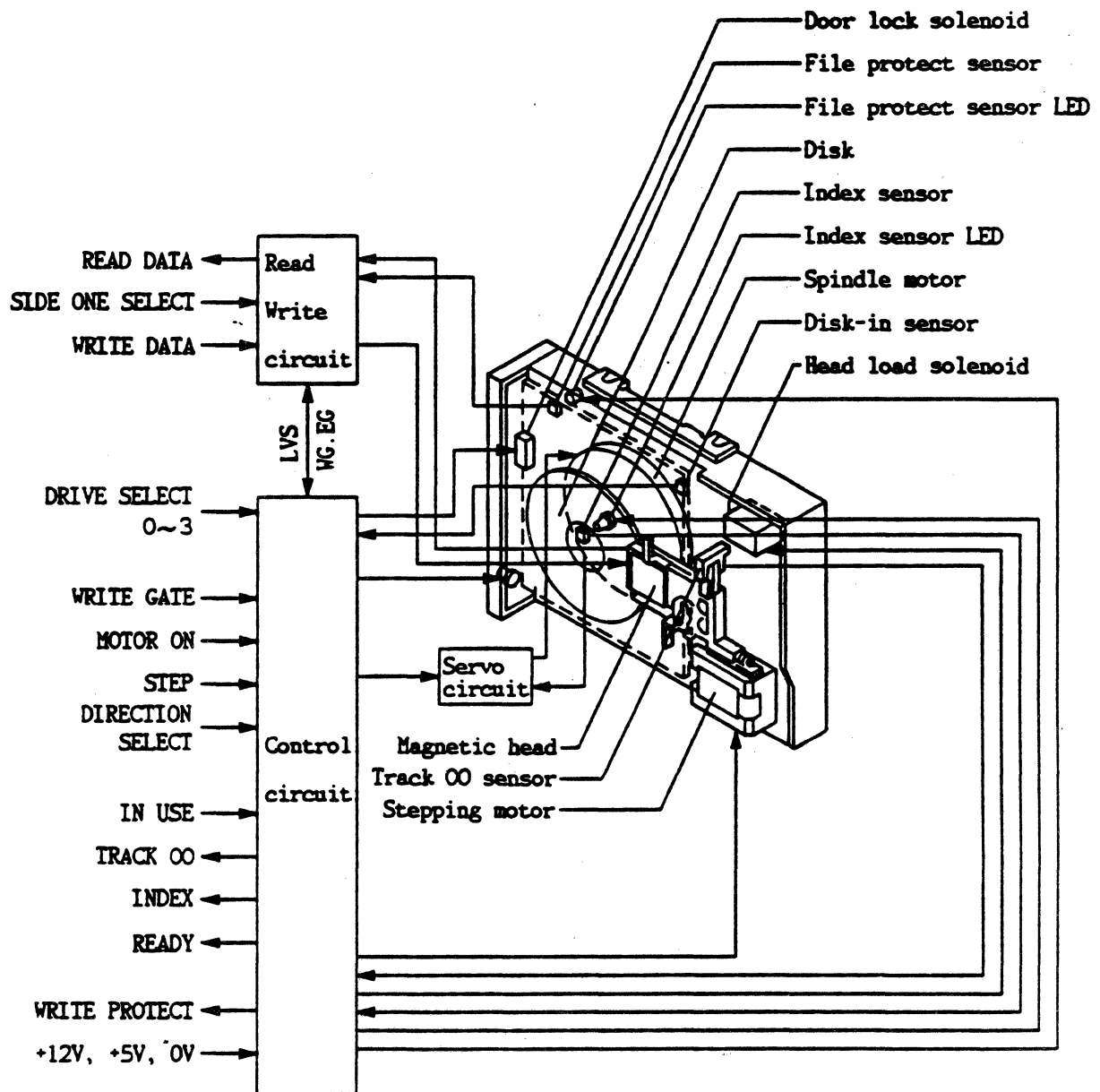

Figure 3-1 Overall Block Diagram

### 3.1.1 Frame Assembly

The frame assembly is the skeleton on which the mechanisms and circuit boards are mounted. This aluminum die cast chassis ensures the drive has the strength, accuracy and expansion ratio required for stable disk drive operations.

### 3.1.2 Door Opening/Closing and Disk Clamping Mechanism

The door opening/closing mechanism includes the clamp spring (flat spring), front lever, and set arm. The disk clamp mechanism (Collet) is moved up and down by the end of the set arm. When a diskette is inserted and the front lever is closed, the collet enters the opening in the center of the disk, and presses against the spindle to ensure the disk is accurately clamped into position.

### 3.1.3 Spindle Mechanism

The disk rotating system is comprised of the spindle and spindle motor. The spindle motor is a direct spindle coupled outer rotor type DC brushless motor with a service life of 20,000 or more hours of continuous operation. The spindle motor rotates at 300 or 360 RPM and maintains a constant speed, even with load and temperature fluctuations, by using feedback signals from an AC tachometer built into the motor.

The spindle and collet are precisely aligned to prevent injury to the center hole of the disk and to allow accurate centering of the disk. This also ensures the heads and disk come into contact at exactly the correct location.

### 3.1.4 Read/Write Head and Carriage

The flat shaped read/write heads are supported by a gimbal. The heads straddle the disk and are mounted on the carriage. The read/write heads are designed to obtain maximum playback from the disk, with minimum head to disk contact pressure.

Refer to Figure 3-2. The tunnel erase read/write heads have a read/write gap to record and playback data, and a tunnel erase gap to trim the edges of each track immediately after it is written.

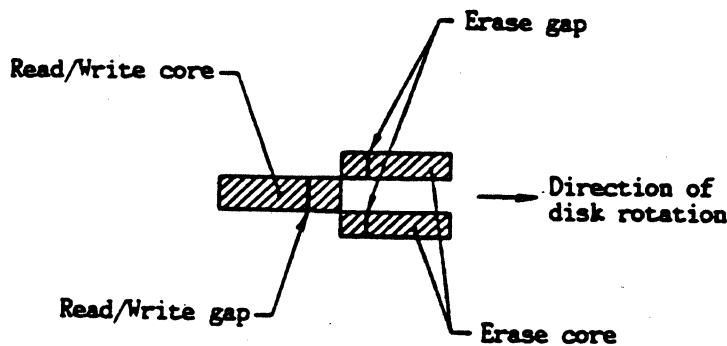

Figure 3-2 Tunnel Erase Type Read/Write Head

### **3.1.5 Seek Mechanism**

The seek mechanism is built around a stepping motor with a capstan (pulley). This mechanism includes a steel band, guide shaft and read/write head carriage. The carriage slides along two guide shafts and is connected to the capstan of the stepping motor via the steel band.

The stepping motor utilizes a 4-phase construction. This stepping motor is driven by single-phase excitation and it rotates one step ( $1.8^\circ$ ) to move the carriage one track.

Parallelism and distance between the shaft and disk center lines, as well as the shaft and capstan, are assembled to close tolerances. Temperature expansion of the chassis, steel band, carriage, and associated items have been carefully studied and designed to counteract the expansion of the disk.

### **3.1.6 Write Protect Detection**

This detector is comprised of a Light Emitting Diode (LED) and photo-transistor. They detect the presence or absence of a write enable notch on the disk jacket. When a disk with a covered notch is inserted, the light path is broken and any operation of the write circuits is prevented. Previously written data is thereby protected, even if a write command is given.

The LED is mounted on the spindle motor circuit card and the photo-transistor sensor is mounted on the write protect circuit card assembly.

### **3.1.7 Track 00 Detection**

The Track 00 detector is comprised of an LED and photo transistor assembly (photo-interrupter) and a mechanical stop. The photo-interrupter provides a signal to the drive's circuitry whenever the head carriage is at the outermost track position (Track 00). The mechanical stop prevents the head carriage from moving beyond Track 00 during a seek operation or when power is initially turned on.

If the head carriage is at its innermost track position, and a step-in command is received, there is enough margin provided to ensure that the heads will not reach the edge of the opening in the disk.

To calibrate the head carriage (return it to Track 00), command the carriage to move several steps beyond the maximum track number. For example, command a M255XK, which has 80 cylinders, to move outward 84 to 86 steps to have it calibrate at track 00.

### **3.1.8 Index Detection**

An LED and photo-transistor are mounted in the drive to detect the Index hole in the disk each time the hole passes the detector. The LED is mounted on the spindle motor circuit board and the photo-transistor is mounted on the sensor block assembly.

### **3.1.9 Diskette Inserted Detection**

The diskette inserted mechanism detects the presence or absence of a diskette in the disk drive.

The diskette inserted detector is comprised of an LED and photo transistor assembly (photo-interrupter). This photo-interrupter provides a signal to the drive's circuitry whenever a diskette is inserted into the drive.

### **3.1.10 Head Load Mechanism**

The head load mechanism extends the service life of the read/write heads and diskettes by allowing them to come into uniform contact with each other, only when necessary.

The head load mechanism is comprised of the head load solenoid, arm lifter assembly, and associated parts.

### **3.1.11 Door Lock Mechanism**

The door lock mechanism locks the front lever during all read or write operations to prevent the door from being opened, and causing damage or the lost of data.

The door lock mechanism is comprised of the door lock solenoid, eject assembly, and associated parts.

## **3.2 CIRCUIT OPERATIONS**

The drive's electronic circuitry is comprised of three major sections:

Read/Write Circuits - explained in paragraph 3.2.1.

Control Circuits - explained in paragraph 3.2.2.

Spindle Motor Servo Circuits - explained in paragraph 3.2.3.

The Read/Write, and Control circuits are mounted on the main circuit board and the Servo circuits are mounted on the spindle motor board.

### **3.2.1 Read/Write Circuits**

The Read/Write circuits include read circuits, write circuits, low voltage detection circuits, and associated sections. These various sections are accommodated in one LSI control circuit. A partial diagram of this LSI control circuit is shown in Figure 3-3.

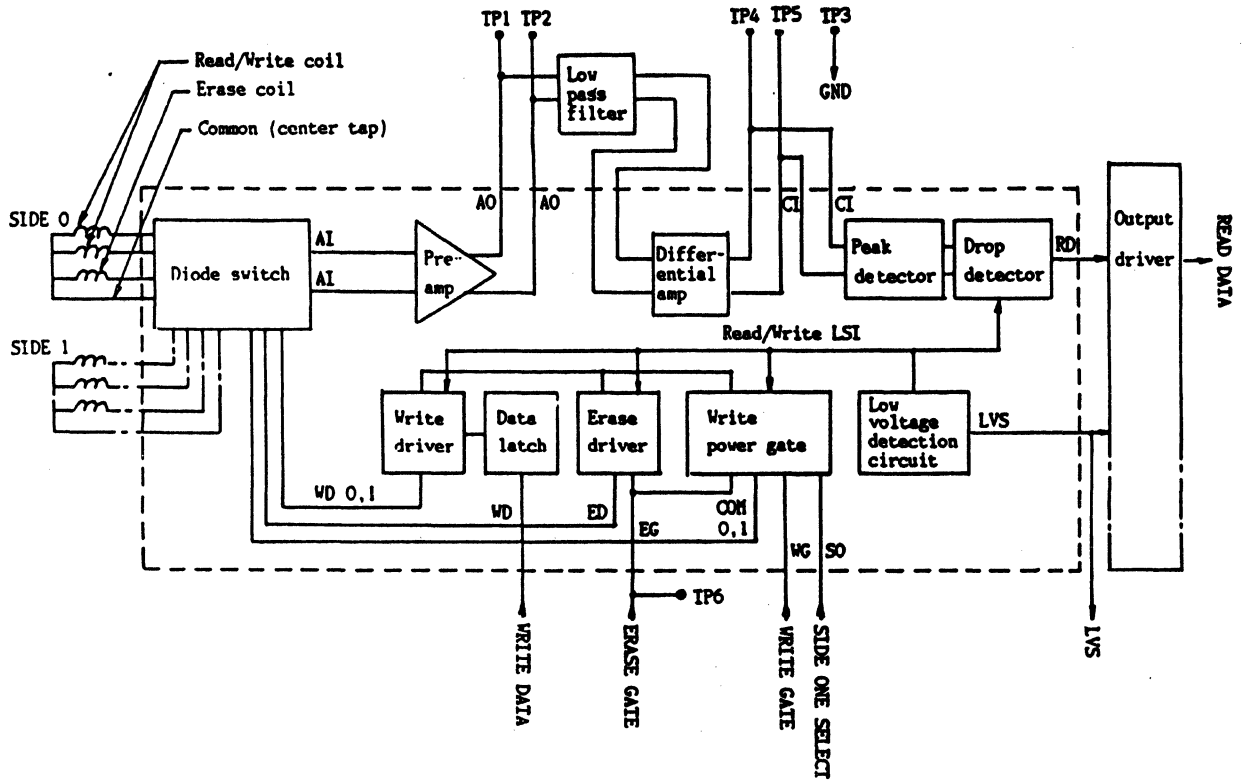

Figure 3-3 Read/Write Circuits

The read circuits includes a pre-amp, low pass filter, differential amp, peak detector, drop detector and read output driver.

Refer to the read circuit timing chart in Figure 3-4. The micro-voltage level signals induced into the Read/Write head during playback is amplified by a pre-amp (a subtraction amplifier) and spurious noise components are removed by a low pass filter. The amplified signal then goes to the differential amp.

The differential amp shifts the playback signal to the zero crossover position and simultaneously applies the proper amount of compensation in accordance with the difference in the frequency components. The signal is further amplified.

The output from the differential amp is converted into a square wave by the peak detector, the bad influence of the saddle (which occurs during playback of the low-frequency signal component approximately 125k Hertz) is eliminated by the drop detector.

The read data signal is driven out of the drive by the read output driver circuit, when Read Gate is true.

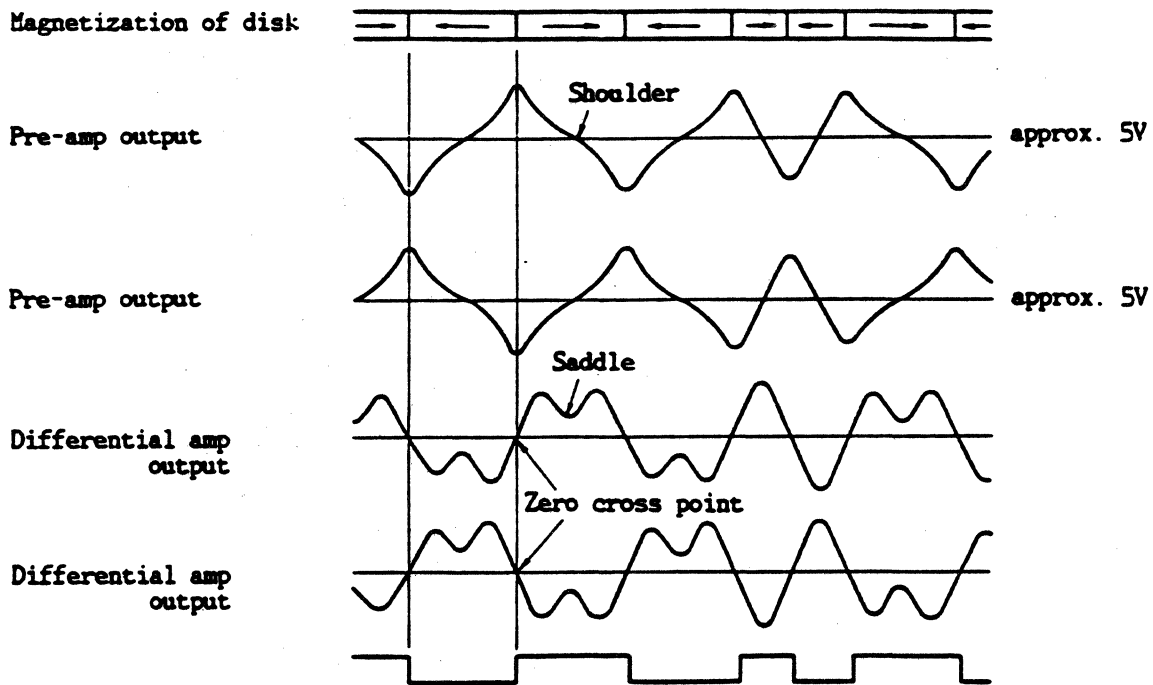

Figure 3-4 Typical Read Circuit Waveforms

The write circuits include the write power gate, erase driver, data latch, write driver, and associated circuits.

The write power gate turns on when the Write Gate (interface input signal) is true and the write protect sensor detects the notch on the side of the diskette (write enable).

The tunnel erase heads are positioned approximately 0.58mm behind the Read/Write gap, and the erase gate signal is activated (to allow for this offset) from the turn-on time of the Write Gate signal.

Refer to the write circuit timing diagram in Figure 3-5. Writing is enabled by +12 Volts being applied to the center tap of the Read/Write head, when the Write Gate interface signal is set true and Write Protect is false.

Externally supplied write data pulse strings are latched by the data latch, and the two write drivers alternately turn on and off to send the proper write current signals to the Read/Write head.

Read Data output is prevented when the write driver is operating.



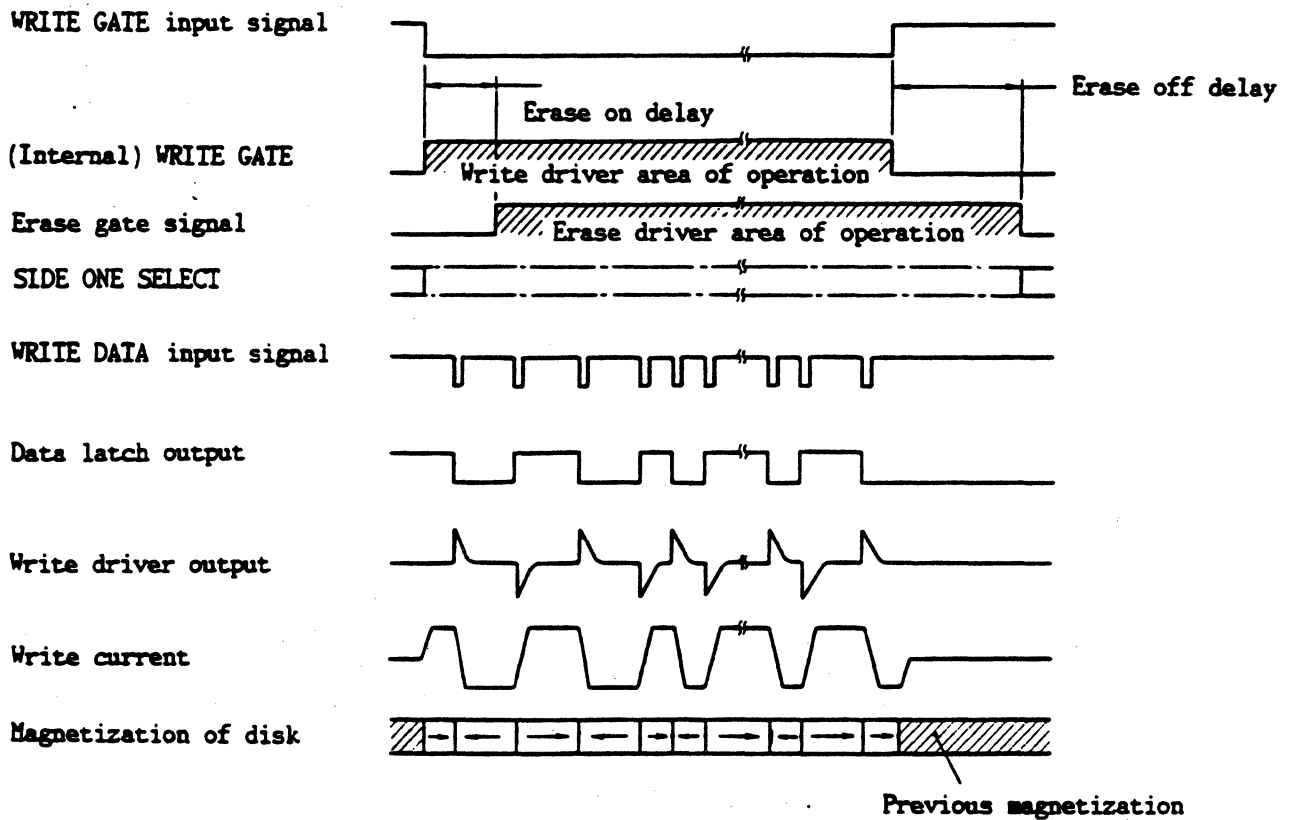

Figure 3-5 Typical Write Circuit Waveforms

Low Voltage Detection circuits are provided to sense low and unstable DC voltages. The output of the low voltage detection circuits prevent the disk drive from writing (or erasing) if the supplied voltage (+5 or +12 VDC) is low or unstable.

These low voltage detection circuits are activated as follows:

+5 VDC circuit will activate if +5 VDC is at 3.6 to 4.0 volts.

+12 VDC circuit will activate if +12 VDC is at 9.2 to 8.2 volts.

### 3.2.2 Control Circuits

Refer to Figure 3-6.

All control circuits are mounted on the main circuit card assembly and are primarily on the Control IC (one chip).

The control circuits receive data from the various sensors and circuits and provide output signals to the Read/Write IC and the interface.

**Detectors** - All detectors (photo-transistors) are mounted on either the write protect circuit card, disk-in sensor assembly, or track 00 sensor assembly. The individual detectors are described in paragraph 3.1.

**Drive Select and Indicator Gate Circuits** - These circuits determine the drive's select status and also when the Front Bezel indicator will be lit. These circuits operate in conjunction with the position of the Drive Select Jumper (Position 0 through 3 which are set by the user) and the corresponding Drive Select interface signal.

**Head Load Gate** - This circuit, in conjunction with selection jumpers, determines the set of conditions that must be present to cause the Read/Write heads to load.

**Write/Erase Gate Circuits** - These circuits determine when current will flow through the Write and Erase coils (in the selected Read/Write Head) for recording on the disk. These circuits operate in conjunction with the Write Gate interface signal. Erase current is delayed (the required period of time) to correspond to the beginning and ending of write current.

**Spindle Motor Gate** - This output circuit determines the speed of the spindle motor.

**Ready Detect Circuits** - This circuit receives Index pulses (from the Index Detector) and sets the Ready signal true when the disk reaches its correct rotational speed.

**Stepping Motor Control Circuits** - These circuits, in conjunction with the over-drive single shot circuit and the Direction and Step interface signals, determine the movement of the Stepping Motor.

The timing chart in Figure 3-7 shows typical stepping motor control waveform.

The output of the Step pulse generator circuit turns on the over-drive circuit for the prescribed time (approximately 30 milliseconds). During this time +12V is activated on the stepping motor coil and a high level of torque is available for seeking and centering the head carriage. After centering is completed, +5V is applied to the stepping motor coil for holding the head carriage at the correct position (and to lower power requirements and excessive heating of the motor coil).

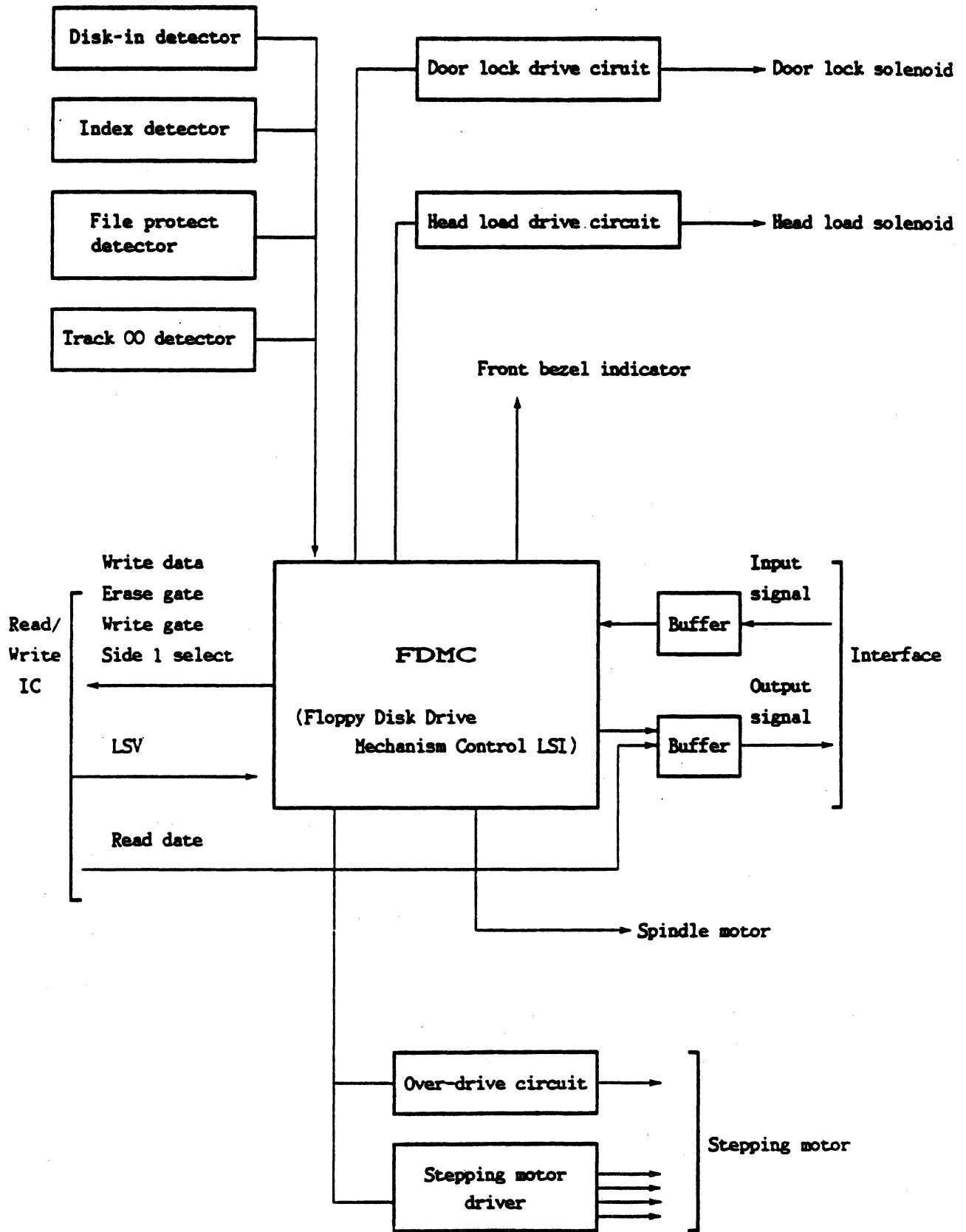

Figure 3-6 Control Circuits

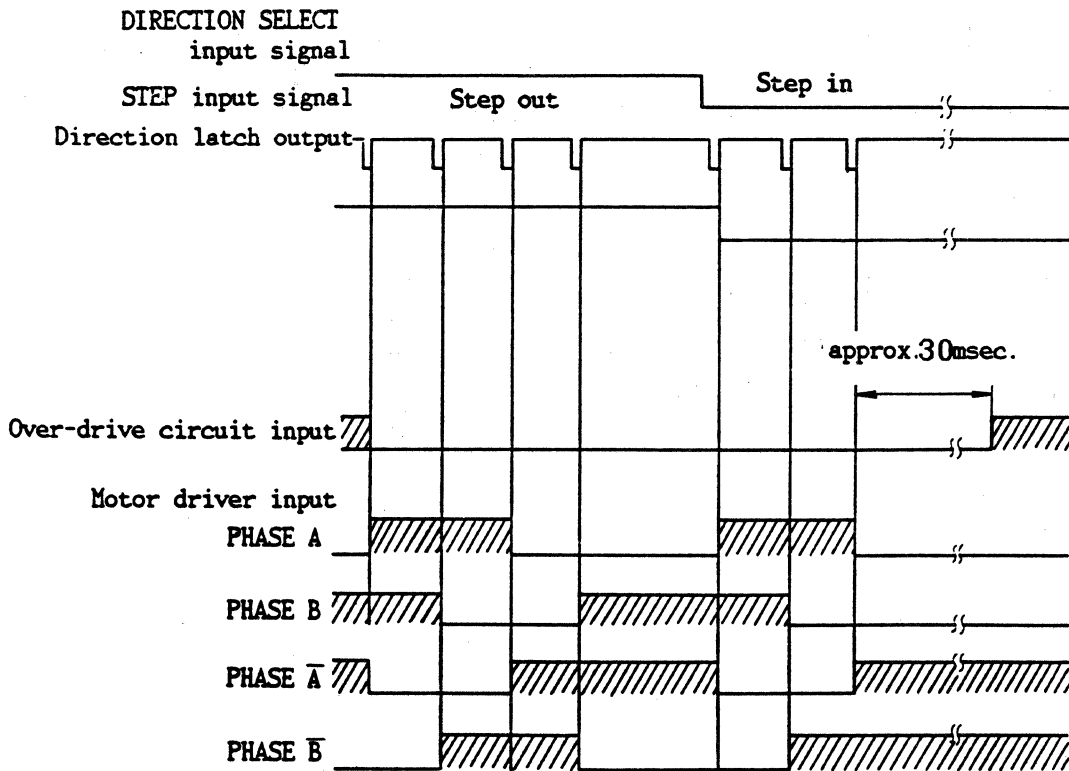

Figure 3-7 Typical Stepping Motor Control Circuit Waveforms

### 3.2.3 Spindle Motor

The Spindle Motor is started and stopped by the "Motor On" interface signal.

The spindle motor is an AC, long life, brushless 3-phase motor driven with a special 3-phase driver IC. The flow of current, and the switching of direction of excitation, is performed by signals from the Hall element mounted on the circuit card on the outer periphery of the motor's rotor, with the sequential drive coil and direction of excitation controlled so they switch to the prescribed direction of rotation.

Rotational speed is accurately maintained, at the desired value, by frequency to voltage conversion of a feedback signal received from an AC tachometer etched on the circuit card inside the motor's rotor. Another servo IC is used to apply this feedback to the voltage control section of the 3-phase driver IC.

### 3.3 TEST POINTS

Connectors and test points on the main circuit card are identified in Figure 3-8 and explained in the following paragraphs.

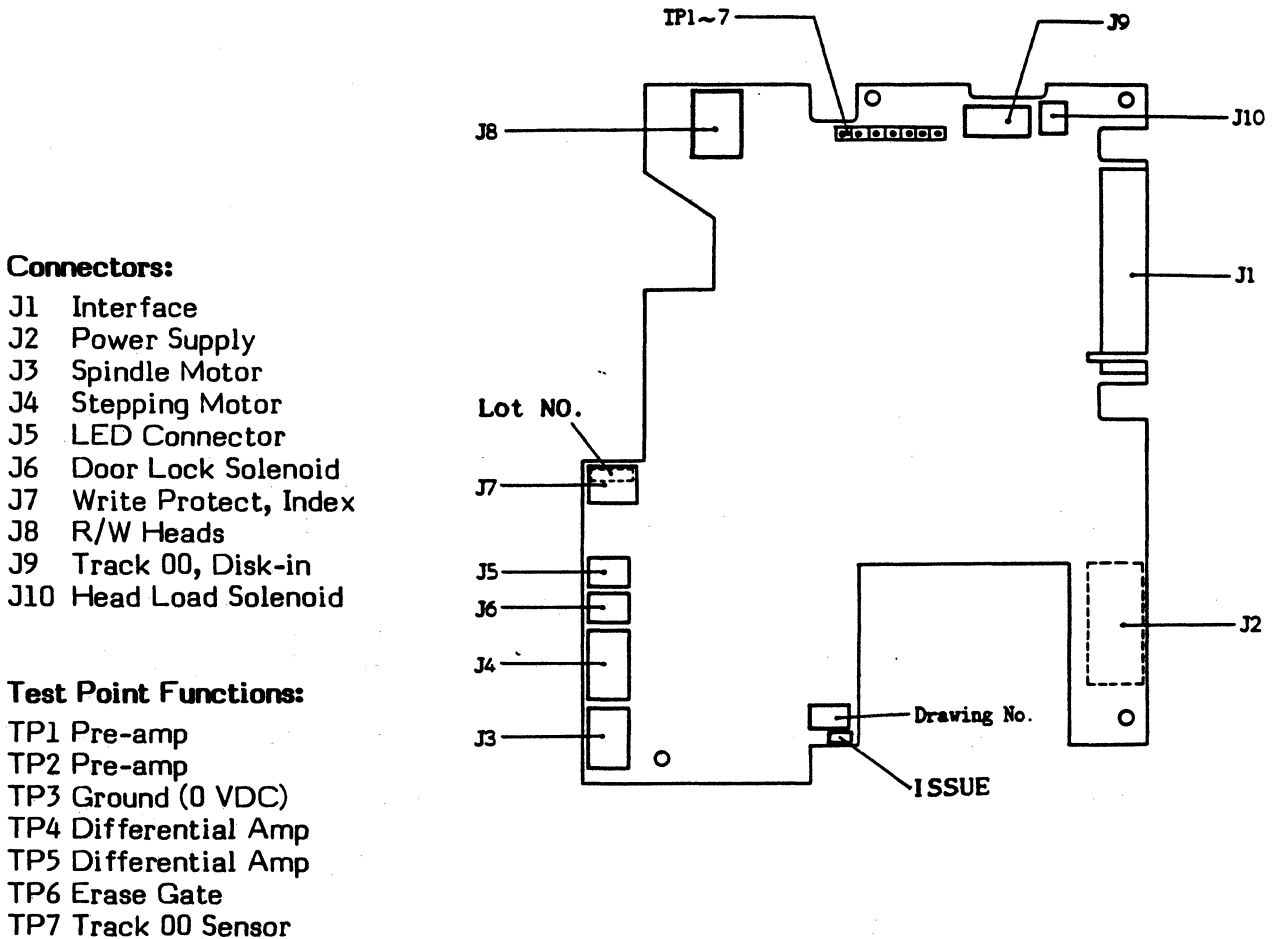

Figure 3-8 Location of Connectors and Test Points

#### 3.3.1 TP1 and TP2 Pre-Amp

Figure 3-9 shows typical TP1/TP2 Pre-amp Waveforms. Use these test points to monitor the Read/Write head output. The pre-amplifier has two phase inverted (180°) outputs that ranges from several tens to several hundreds of millivolts peak-to-peak.

For accurate waveform monitoring, a dual trace (2-channel) oscilloscope should be used (with one channel set to the inverted ADD input mode) to monitor TP1 and TP2 as one waveform. The oscilloscope can be grounded at TP3.

### 3.3.1 TP1 and TP2 Pre-Amp (Continued)

TP1 and TP2 are available for checking the characteristics of the Read/Write head signal.

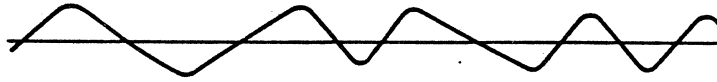

Figure 3-9 TP1/TP2 Typical Pre-Amp Waveform

### 3.3.2 TP3 Ground

Used for grounding test instruments. Use care when connecting a probe to TP3 to prevent shorting nearby test points.

### 3.3.3 TP4 and TP5 Differential Amp

These test points are used to monitor the output from the Differential Amplifier. The Differential Amp (like the Pre-Amp and 2nd Amp) also has two phase inverted (180°) outputs that ranges from several tens to several hundreds of millivolts peak-to-peak. Figure 3-10 shows typical TP1/TP2 Differential Amp Waveforms.

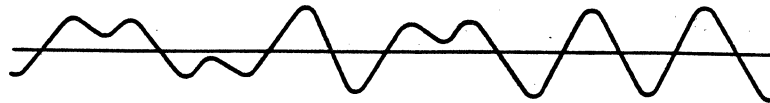

Figure 3-10 TP4/TP5 Typical Differential Amp Waveform

For accurate waveform monitoring, a dual trace (2-channel) oscilloscope should be used (with one channel set to the inverted ADD input mode) to monitor TP4 and TP5 as one waveform. The oscilloscope can be grounded at TP3.

TP4 and TP5 are available for checking the overall operation of the read/write head and amplifiers, and for checking track alignment.

### 3.3.4 TP6 Erase Gate

Figure 3-10 shows a typical TP6 Waveform. Current is flowing in the erase head at the low level. TP6 is used to check Erase Gate to Write Gate delay

On Delay time = 262 ±24 microseconds at 1MB (194 ±24 microseconds at 1.6MB).  
Off Delay time = 776 ±24 microseconds at 1MB (524 ±24 microseconds at 1.6MB).

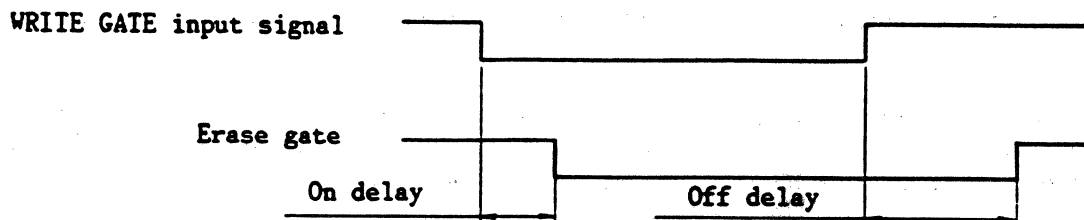

Figure 3-11 TP6 Typical Erase Gate Waveform

### 3.3.5 TP7 Track 00 Sensor

Figure 3-12 shows a typical Track 00 waveform. The Track 00 photo-transistor detects when the head carriage is at Track 00. Like the Track 00 interface signal, this signal is Low only when the head is at or near track 00.

**Note:** Track 00 output signal becomes True (low level) while the basic excitation phase for the stepping Motor is excited. Because of this, the timing of the waveform variation is not constant.

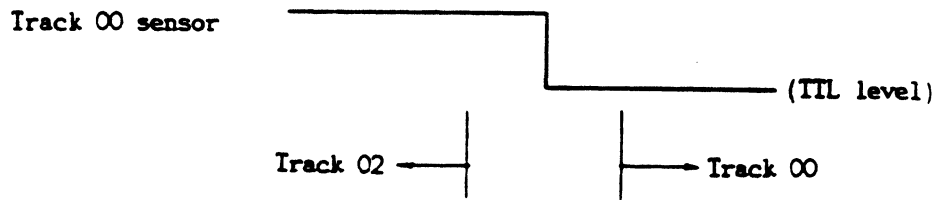

Figure 3-12 TP7 Track 00 Detect Waveforms





**SECTION 4  
MAINTENANCE**

**4.1 PERIODIC MAINTENANCE**

When used at a normal rate, periodic maintenance such as cleaning, adjusting, replacing parts, and lubricating should not be required for 5 years. Paragraph 4.3 provides additional information on cleaning the read/write heads.

**4.1.1 Inspection and Adjustment Items**

Table 4-1 lists the items that may require inspection, replacement or adjustment. The paragraph number, listed under the "Refer To" column in Table 4-1, provides additional information or a step-by-step removal and replacement procedure.

The time required to perform each item listed in Table 4-1 is approximately 5 minutes, with the exception of the Track Inspection and Adjustment - which takes about 10 minutes to perform.

**Table 4-1 Inspection and Adjustment Items**

<b>Item</b>	<b>Refer To</b>
Collet Assembly - Centering Adjustment	4.4.1
Bail - Inspection and Adjustment	4.4.2
Disk-in Sensor - Inspection	4.4.3
Write Protect Sensor - Inspection	4.4.4
Disk Speed - Inspection and Adjustment	4.4.5
Head Contact - Inspection and Adjustment	4.4.6
Asymmetry - Inspection and Adjustment	4.4.7
Read Level - Inspection	4.4.8
Resolution - Inspection	4.4.9
Track - Inspection and Adjustment	4.4.10
Track 00 Sensor - Inspection and Adjustment	4.4.11
Index Burst - Timing, Inspection and Adjustment	4.4.12
Head Load - Inspection and Adjustment	4.4.13
Door Lock Inspection	4.4.14

**4.1.2 Field Replaceable Items**

Table 4-2 lists the field replaceable items that may require replacement due to wear or breakage. The paragraph number, listed under the "Refer To" column in Table 4-2, provides a step-by-step removal and replacement procedure.

Refer to the Maintenance Precautions given in paragraph 4.2 prior to replacing any item in the disk drive.

**Table 4-2 Field Replaceable Items**

Item	Part Number	Replacement Interval	Refer To
Head Carriage Assembly	JA3-5321	7,000 Operating Hours or $5 \times 10^6$ Seeks	4.5.1
Stepping Motor	J3-5295	$5 \times 10^6$ Seeks	4.5.2
Steel Band Assembly	JA4-5674	$5 \times 10^6$ Seeks	4.5.2
Spindle Motor	J3-5294	20,000 Operating Hours	4.5.3
Collet Assembly	JA3-5265	If defective	4.5.4
Sensor Card Assembly	JA4-5717	If defective	4.5.5
Main Circuit Card	Note 1	If defective	4.5.6
Write Protect Card	JA4-5715	If defective	4.5.7
Front Bezel Assembly	JA4-5207	If defective	4.4.8
Front Lever Assembly	JA4-5708	If defective	4.4.9
Clamp Cam Assembly	JA4-5698	If defective	4.4.10
LED Circuit Card	JA4-5716	If defective	4.4.11

Note 1: Obtain replacement part number from the old Circuit Card.

Note 2: Front Bezel and Front Lever Assembly part numbers are black items, order other colors with a color drawing number.

#### 4.1.3 Tools Required for Maintenance

Table 4-3 list the tools that may be required to perform an inspection, replacement or adjustment procedure.

**Table 4-3 Maintenance Tools**

<b>Measuring Instruments:</b>	Exerciser (AVA 409 or equivalent) Dual Trace Oscilloscope 34-pin Intraconnector Adaptor AP Products Part Number 922576-34-I Relative Humidity Gauge
<b>Hand Tools:</b>	Phillips Screwdrivers (M2.6 and M3) Flat Blade Screwdriver (small and medium) Allen Wrench Set (1.5mm flat) Tweezers, Needle Nose Pliers and Wire Cutters Soldering Iron and Solder Fine Cleaning Brush

**Table 4-3 Maintenance Tools (Continued)**

<b>Diskettes:</b> (Recommended)	Commercially available Work/Scratch Diskette (M2552K = Dysan 802067, M2553/54K = Dysan 802914) Commercially available Cleaning Diskette (Dysan = 802944) Read Level Diskette Alignment Diskette (M2552K = Dysan 206-31, M2553/54K = Dysan 206-34)
<b>Maintenance Supplies:</b>	Anhydrous Alcohol (Ethyl Alcohol) Cotton Gauze Screw Lock Liquid Epoxy Adhesive Lubricating Oil (Kanto Kasel 946P, or equivalent) Light Oil (Nippon Koyu HH-17, or equivalent)
<b>Special Jig:</b>	MAX Media Jig (Jig D)

## 4.2 MAINTENANCE PRECAUTIONS

Ensure the following precautions are observed whenever working on the disk drive.

### 4.2.1 Screw Torque

Unless otherwise specified, all screws are tightened, according to their size, to the torque values listed in Table 4-4.

**Table 4-4 Screw Size and Torque**

Screw Size	Torque
M2	11 Inch Pounds (2 Kilograms cm)
M2.6	24 Inch Pounds (4.5 Kilograms cm)
M3	33 Inch Pounds (6 Kilograms cm)
M3 setscrew	24 Inch Pounds (4.5 Kilograms cm)

### 4.2.2 Screw Lock

Use screw lock as specified below:

1. When making an adjustment, remove the holding setscrew and clean old screw lock liquid off the setscrew and hole as completely as possible.
2. Before replacing a setscrew (or any screw), apply screw lock liquid to the first three threads.
3. When replacing a screw or setscrew, tighten it to the designated torque.

### 4.2.3 Handling Connectors

Handle connectors as specified below:

- Always turn power Off before inserting or removing a connector.
- Do not apply excessive force to the cable or post pin.
- Remove/insert each connector by pulling/pushing in a straight manner.

### 4.2.4 Additional Maintenance Precautions

#### Overall Error Test

Perform the Inspection and Adjustment procedures given in paragraph 4.4 when inspecting, adjusting or replacing parts. Procedures in paragraph 4.4 do not include data Read/Write checks, connect the drive to a test system and perform a window margin test to ensure data integrity.

#### Diskette

Never use a defective work, or test diskette during a maintenance action.

#### Set Jumper Selections

Set Drive Select (DS0 through DS3) and all jumper selections to be compatible with the test system, as given below:

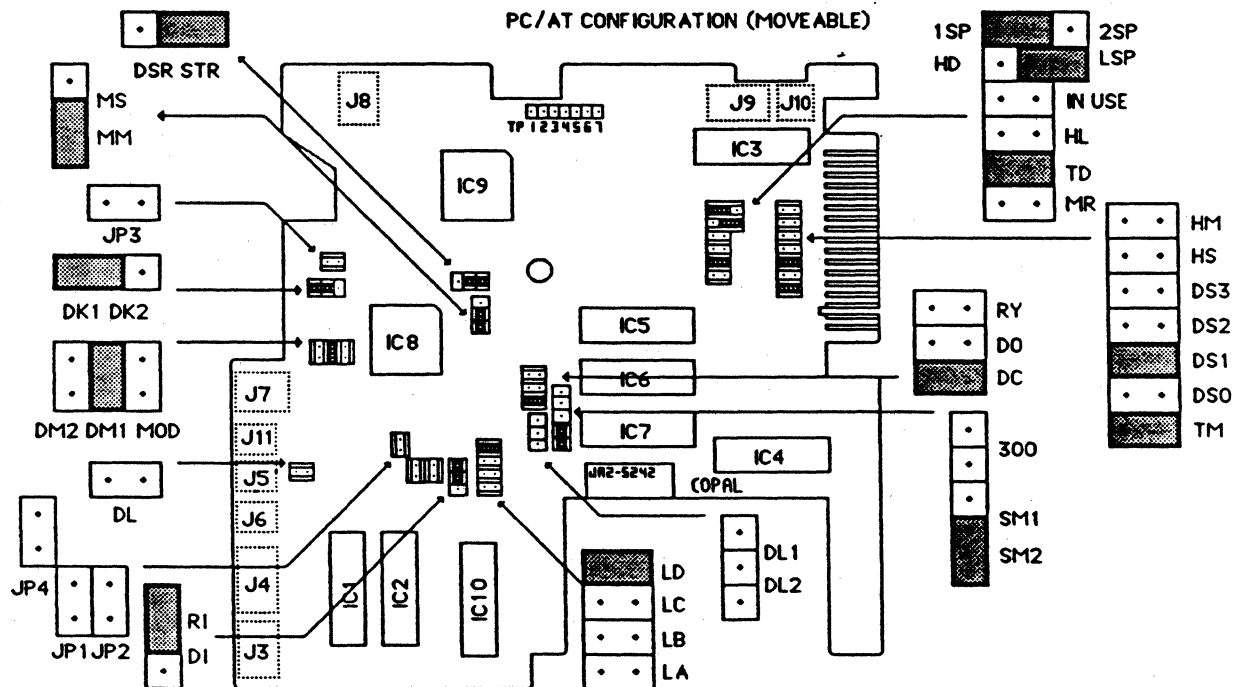
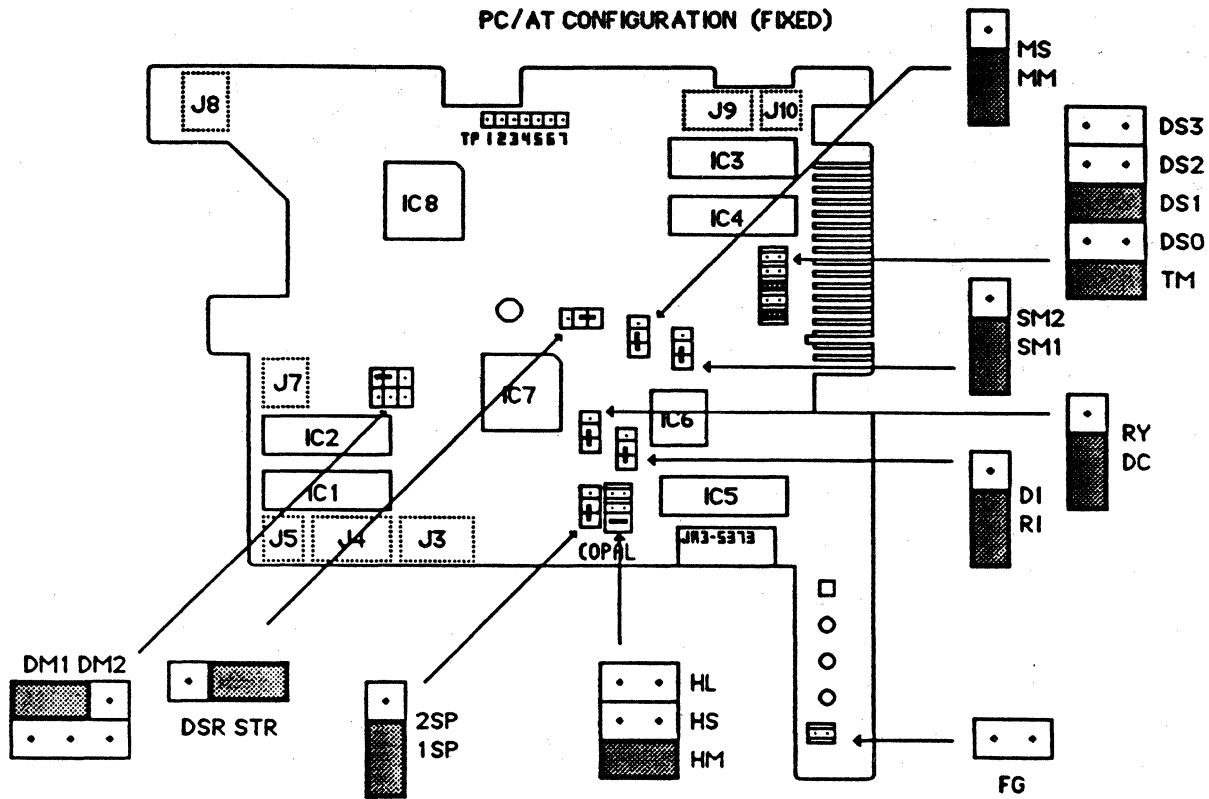

Figure 4-1A M2553K/54K Revision 2 Circuit Card - Jumper Locations

Table 4-5A M2553K/54K Revision 2 Circuit Card Jumper Definitions

M2553K and M2554K High Density	M2554K Low Density	M2554K Dual Speed	M2553K and M2554K IBM PC/AT	Jumper	Definition
Install Open	Open Install	Open Install	Install Open	1 SP 2 SP	360 RPM Only Motor speed and R/W circuits changed in tandem
Install Open ** (X)	Open Open ** (X)	Open Install ** (X)	Open Install Open Open	HD LSP In Use HL	High Density sense output Density controlled by pin 2 LED Lit with pin 4 Head Load with pin 4
Install Install (* (* DS0	Install Install (* (* DS0	Install Install (* (* DS0	Install Open (* (* DS1	TD MR HM HS DS0-3	Terminator for Drive Select Pin 34 gated with Drive Select Head Load with Motor-on Head Load with Drive Select Drive Select
Install Install ** **	Install Install ** **	Install Install ** **	Install Open Open Install	TM RY DO DC	Terminator for input signal lines Ready to pin 34 Door Switch Ready to pin 34 Disk Change to pin 34
Open Open Open Install (* (*	Install Open Open Install (* (*	Open ** ** Install (* (*	Open Open Install Open Install Open	300 SM1 SM2 DSR STR MS	Low Density 300 RPM always Density and Speed Control Latched Density and Speed Control Unlatched Disk change reset with Drive Select Disk change reset with step Motor on with Drive Select
Install Open Install Open	Install Open Install Open	Install Open Install Open	Install Open Install Open	MM JP3 DK1 DK2	Motor on with pin 16 Motor always on Disk-in Sensor Enabled Disk-in Sensor and Dynamic Clamping Disabled
Open Open ** (*	Install Open ** (*	Install Open ** (*	Open Install Open Open	DM2 DM1 MOD DL	FWS3 Active FWS2 Active Motor-Off Delay Door Lock with LD, LC, LB or LA
Open Open Open **	Open Open Open **	Open Open Open **	Open Open Open Open	JP4 JP1 JP2	Undefined No Index during Step No Read Data during Step
Open ** ** **	Open ** ** **	Open ** ** **	Open Install Open Open Open	RI DI LD LC LB	Index gated with Pre Ready Index Gated with Drive Select LED Lit with DL1 or DL2 LED Lit with Drive Select and Ready LED Lit with LED 0
Install Open	Install Open	Install Open	Install Open	LA DL1	LED Lit with Drive Select LED Lit with Drive Select and Head Load Ready
Open	Open	Open	Open	DL2	LED Lit with Drive Select or In-use Latch and Head Load Ready



**Table 4-5B M2553K Revision 3 Circuit Card  
Jumper Definitions**

M2553K IBM PC/AT	Jumper	Definition
Open	MS	Motor on with Drive Select
Shorted	MM	Motor on with pin 16
DS1	DS0-3	Drive Select
Install	TM	Terminator for input signal lines
Shorted	SM2	Density and Speed Control Unlatched
Open	SM1	Density and Speed Control Latched
Open	RY	Ready to pin 34
Shorted	DC	Disk Change to pin 34
Shorted	RI	Index gated with Pre Ready
Open	DI	Index gated with Drive Select
Open	FG	Frame Ground
Open	HL	Head Load with pin 4
Open	HS	Head Load with Select
Shorted	HM	Head Load with pin 16
Open	2 SP	Motor speed and R/W circuits changed in tandem
Shorted	1 SP	360 RPM Only
Open	DSR	Disk change with Drive Select
Shorted	STR	Disk change reset with step
Open	DM2	FWS3 Active
Shorted	DM1	FWS2 Active

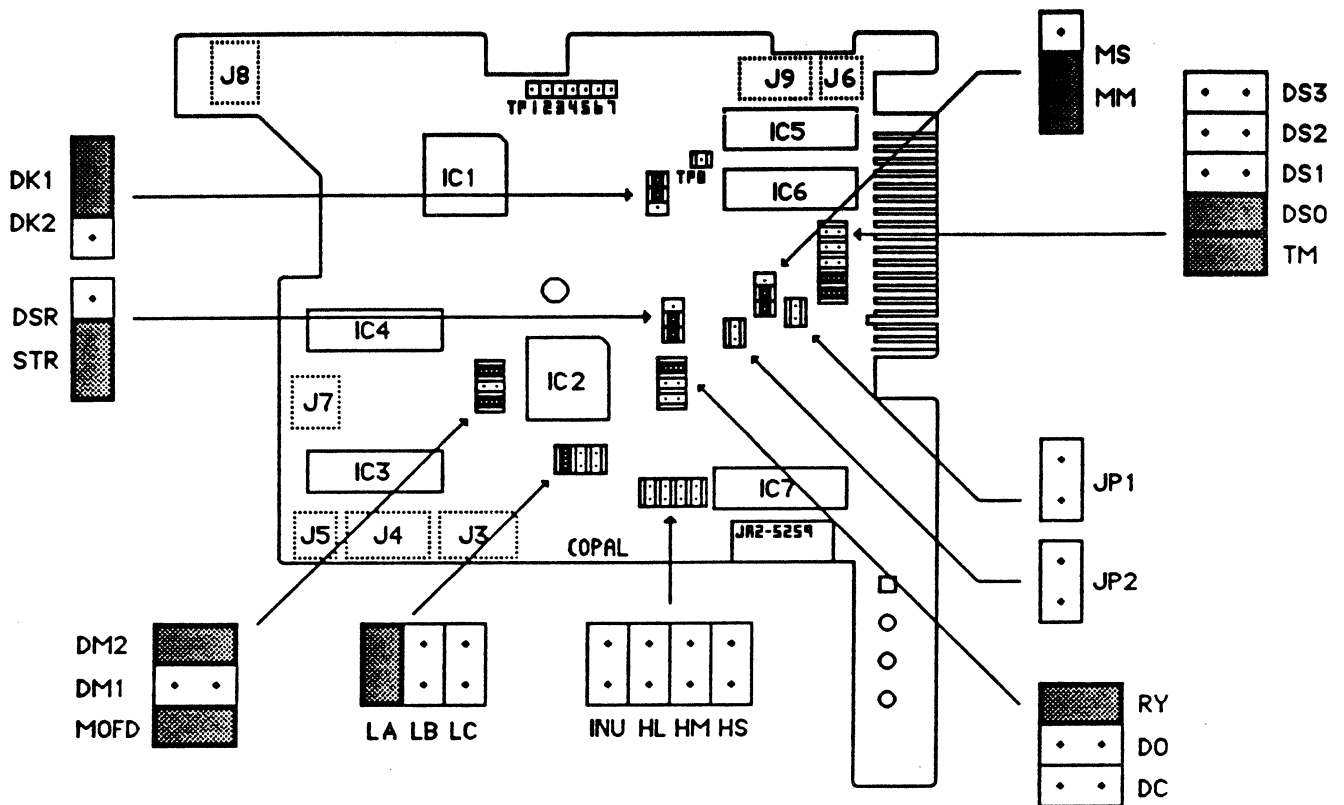

Figure 4-1C M2552K Revision 1 Circuit Card - Jumper Locations

Table 4-5C M2552K Revision 1 Circuit Card Jumper Definitions		
Factory	Jumper	Definition
Open	MS	Motor on with Drive Select
Install	MM	Motor on with pin 16
(DS0)	DS0-3	Drive Select
Install	TM	Terminator for input signal lines
Open	JP1	No Index during Step
Open	JP2	No Read Data during Step
Install	RY	Ready to pin 34
*	DO	Door Switch Ready to pin 34
Open	DC	Disk Change to pin 34
Open	In Use	LED Lit with pin 4
(*)	HL	Head Load with pin 4
Open	HM	Head Load with pin 16
Open	HS	Head Load with Select
Open	LC	LED Lit with Drive Select and Ready
Open	LB	LED Lit with LED 0
Install	LA	LED Lit with Drive Select
Install	DM2	FWS3 Active
Open	DM1	FWS2 Active
Install	MOFD	Motor-Off Delay

#### 4.2.4 Additional Maintenance Precautions (Continued)

##### Operating Environment

Perform disk drive maintenance on a clean bench in normal temperature and humidity conditions. If the work bench is not clean, dust or dirt can adhere to the Read/Write heads, disk, and other sensitive components.

Head alignment checks and adjustments should be done in an environment at 65° F  $\pm 2^{\circ}$  and 55% Relative Humidity. Head alignment, inspection and adjustment should be made after leaving the drive in the room for 2 hours or more, allowing it to adjust to this ideal temperature and humidity conditions.

##### Ground Probe Connection

When measuring Test Points on the Main Circuit Card use TP3 (Ground), on the Main Circuit Card, to ground the instrument.

When measuring a Test Point not the main Circuit Card, use TP3, or a Ground point on the drive or on the user's system.

##### Disk Drive Orientation

Unless indicated otherwise, Disk Drive inspections and adjustments may be made with the unit placed horizontally or vertically as shown in Figure 4-2.

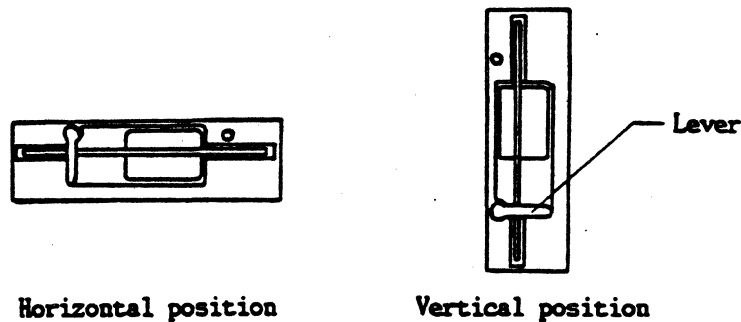

Figure 4-2 Disk Drive Orientation During Maintenance

#### 4.3 HEAD CLEANING

When the drive is used in a dusty environment, it is advisable to periodically clean the Read/Write heads with a commercially available cleaning disk. Cleaning the heads may improve data reliability, even in a normally clean environment.

Approximately 5 minutes are required to clean the Read/Write heads, when using a commercially available cleaning disk.

Use the cleaning disk at the intervals recommended and with the procedure given on the package of the cleaning disk.

Optimum cleaning time varies with the type of cleaning disk used. Excessive cleaning will not accomplish better performance and may even cause premature head wear.



## 4.4 INSPECTION AND ADJUSTMENT PROCEDURES

The following step-by-step procedures are provided to ease any maintenance task.

### 4.4.1 Collet Assembly Centering Adjustment

Tools Required: Phillips Screwdriver, M3  
Screw Lock Liquid

Refer to Figure 4-3.

1. Remove the 3 screws fastening the shield cover to the drive and remove the cover.
2. Loosen the 2 screws fastening the collet shaft assembly (allowing the shaft assembly to be moved manually).
3. Place a piece of felt, or similar material between the Read/Write heads to prevent contact between the heads, and then release the door lock cam and turn the Front Lever to clamp.
4. Adjust the collet shaft assembly so the collet shaft slides smoothly against the collet core. Then press the collet shaft assembly in the direction of the arrow, and tighten its fastening screws.
5. Turn the Front Lever to open and close the collet:

Make sure the operation is performed smoothly, without catching on the spindle cap.

6. Install the shield cover.

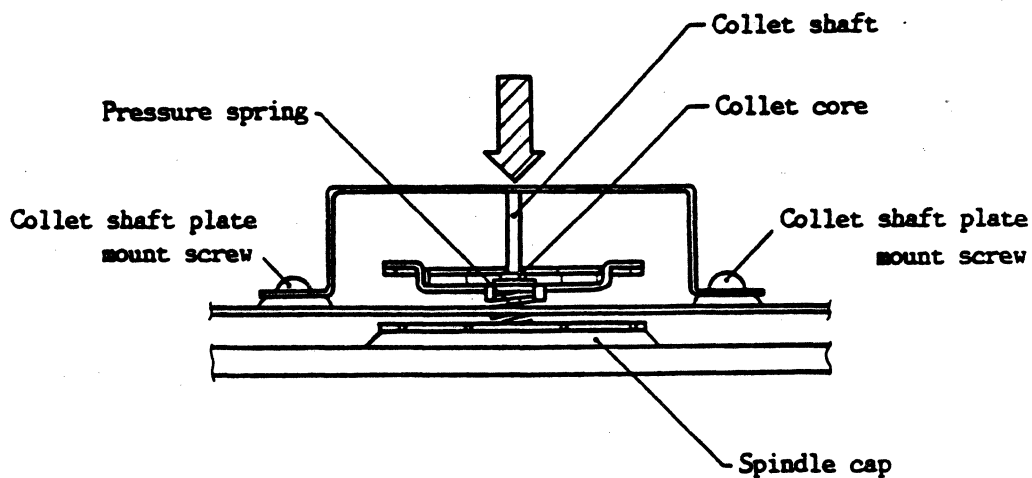

Figure 4-3 Collet Shaft Adjustment

#### 4.4.2 Bail Inspection and Adjustment

Tools Required: Phillips Screwdriver, M3  
Screw Lock Adhesive

Refer to Figures 4-4 and 4-5.

1. Open the Front Lever so a disk can be inserted.
2. Check the gap between the bail assembly and the Spindle Motor. If the gap is not 0.35" (9mm) turn the bail assembly adjustment screw to adjust the gap.
3. Check that the upper arm does not contact the bail when the front lever is closed (clamped).
4. Slowly insert a disk and ensure there is sufficient clearance for the disk to be inserted without the jacket contacting either read/write head.
5. Repeat inserting and ejecting the disk 2 or 3 times to be certain the eject clamp operation is smooth.
6. Check for sufficient clearance for the diskette to be inserted/ejected without the head window (the opening in the disk jacket through which the read/write heads contact the disk surface) catching on either read/write head.
7. Coat the adjustment screw with Screw Lock Adhesive and fasten the bail.

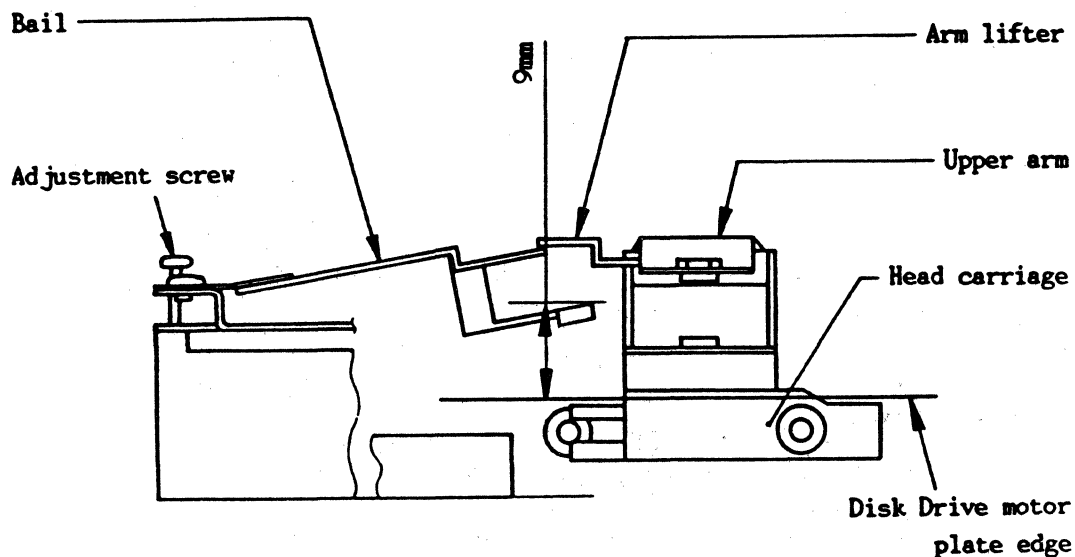

Viewed from the Front Bezel Side

Figure 4-4 Bail Height Adjustment

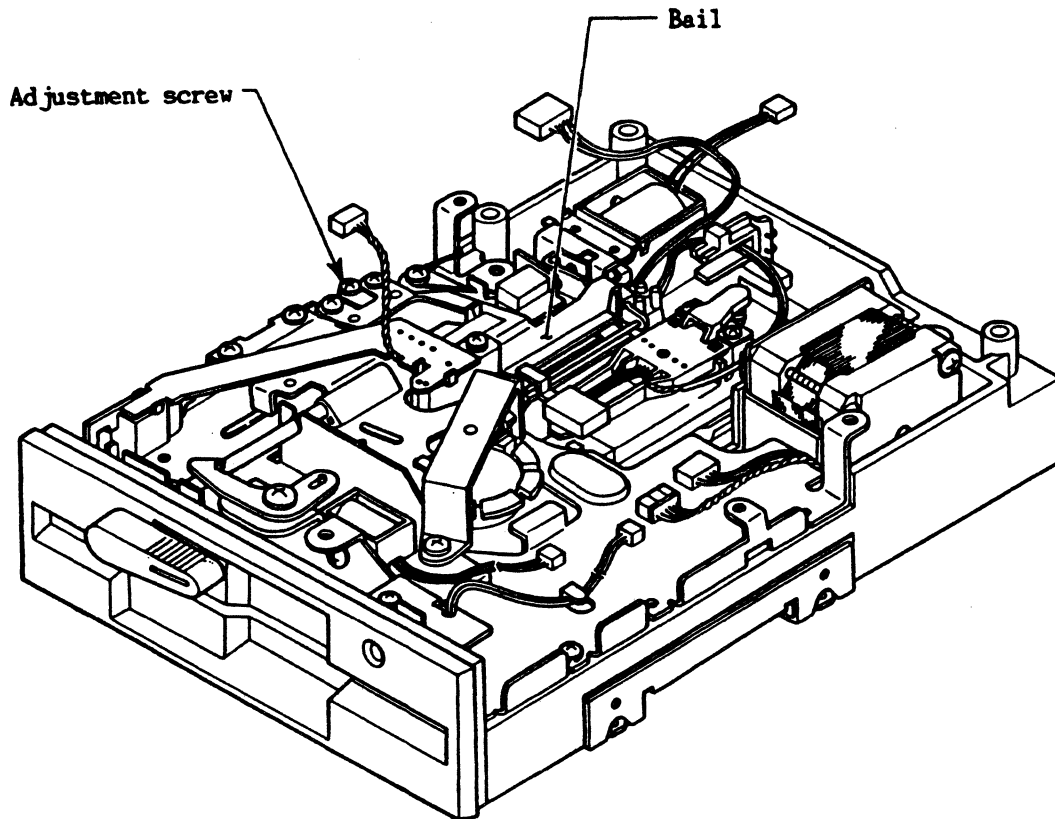

Figure 4-5 Bail Adjustment

#### 4.4.3 Disk-in Sensor Inspection

Tools Required: Work/Scratch Diskette  
Oscilloscope  
Disk Drive Power Supply

1. Place the Disk Drive on its side, with the LED indicator downward and the Front Lever upward.
2. Connect an Oscilloscope (DC range 1V/div) to J9 pin 6.
3. Turn-on power to the disk drive and check that the voltage is 0.5V or less when a diskette is not inserted.
4. Insert a diskette and check that the voltage is 2.5 V or more.

#### 4.4.4 Write Protect Sensor

Tools Required: MAX Media Jig (Jig D)  
Oscilloscope  
Disk Drive Power Supply

Refer to Figure 4-6.

1. Place the Disk Drive on its side, with the LED indicator downward and the Front Lever upward.
2. Connect the oscilloscope (DC range at one volt per division) to the Write Protect signal on the interface connector (pin-28).
3. Mount the MAX Media Jig in the position shown in Figure 4-6. Be sure that notch A is above the light path of the Write Protect sensor.
4. Move the Drive if strong external light is striking the Write Protect sensor.
5. Make sure the Write Protect interface signal (pin-28) reads 0.5 volts or less (with the jig at the notch A position) with Disk Drive power turned on.
6. Pull the jig out slightly, so notch B is in the light path.
7. Make sure the Write Protect interface signal (pin-28) reads 3.0 volts or more (with the jig at the notch B position) with Disk Drive power turned on.

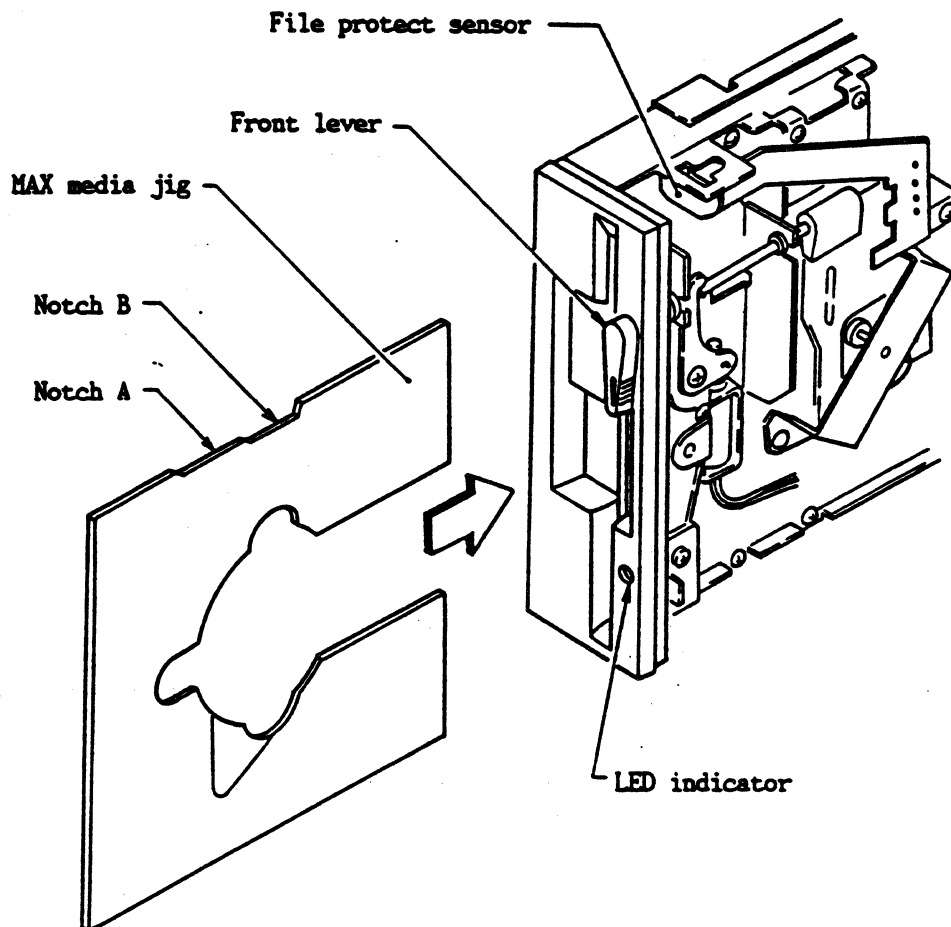

Figure 4-6 Write Protect Sensor

#### 4.4.5 Disk Rotational Speed

Tools Required: Disk Drive Power Supply  
Exerciser (AVA 409 or equivalent)  
Oscilloscope  
Soft Sector Work/Scratch Diskette

Proceed as follows:

1. Connect the frequency counter to the INDEX interface signal (pin-8).
2. Start the Spindle Motor and load the work/scratch diskette.
3. Seek the Read/Write heads to Track 00.
4. Make sure the timing interval of the INDEX interface signal is  $200 \pm 3$  milliseconds at 300 RPM and  $166.7 \pm 2.5$  milliseconds at 360 RPM.

#### 4.4.6 Head Contact Inspection and Adjustment

Tools Required: Work/Scratch Diskette  
Flat Blade Screwdriver, small  
Exerciser (AVA 409 or equivalent)  
Oscilloscope  
Screw Lock Liquid

Proceed as follows:

1. Connect the oscilloscope to TP1, TP2 (Pre-amp Test Points) on the main circuit card. Set the oscilloscope range to AC mode, 0.2V.
2. Load the work/scratch diskette and start the Spindle Motor.
3. Seek the Read/Write heads to the innermost track.
4. Record and then read a constant "2F" on the entire track (2F is a 1's only WRITE DATA frequency of 250kHz for M2552K and 500kHz for M2553/54K).
5. Write down the average values shown on the oscilloscope while performing step 4.
6. Refer to Figure 4-7. Insert a thin rod into the inspection hole "1" of the Main Circuit Card and press the top of the head very slightly to apply about 4 to 7 ounces (10 to 20 grams). Repeat steps 4 and 5 with the weight applied.
7. Compare the average values found in steps 5 and 6. Ensure the Read Level measured in step 5 is 80% or more of the value measured in step 6.
8. Repeat steps 4 through 7 for side 0 and side 1.
9. Seek the Read/Write heads to Track 00 and repeat steps 4 through 8.

#### 4.4.6 Head Contact Inspection and Adjustment (Continued)

10. If the results of steps 4 through 9 are not satisfactory, the following items are probable causes:

(a) Faulty Diskette

If the diskette or its jacket is bent or damaged, replace it with a new one and retry the test.

(b) Faulty Head Pressure

The movable flat spring that rides on the white part of the Read/Write head may need adjustment (refer to paragraph 4.4.2).

Refer to paragraph 4.5.1, if the head carriage is defective and must be replaced.

(c) Deformation of the Diskette

Deformation, or bending, of the diskette is checked by removing the diskette, then slowly opening and closing the Front Lever while visually checking the Read/Write heads to be sure the surfaces are parallel.

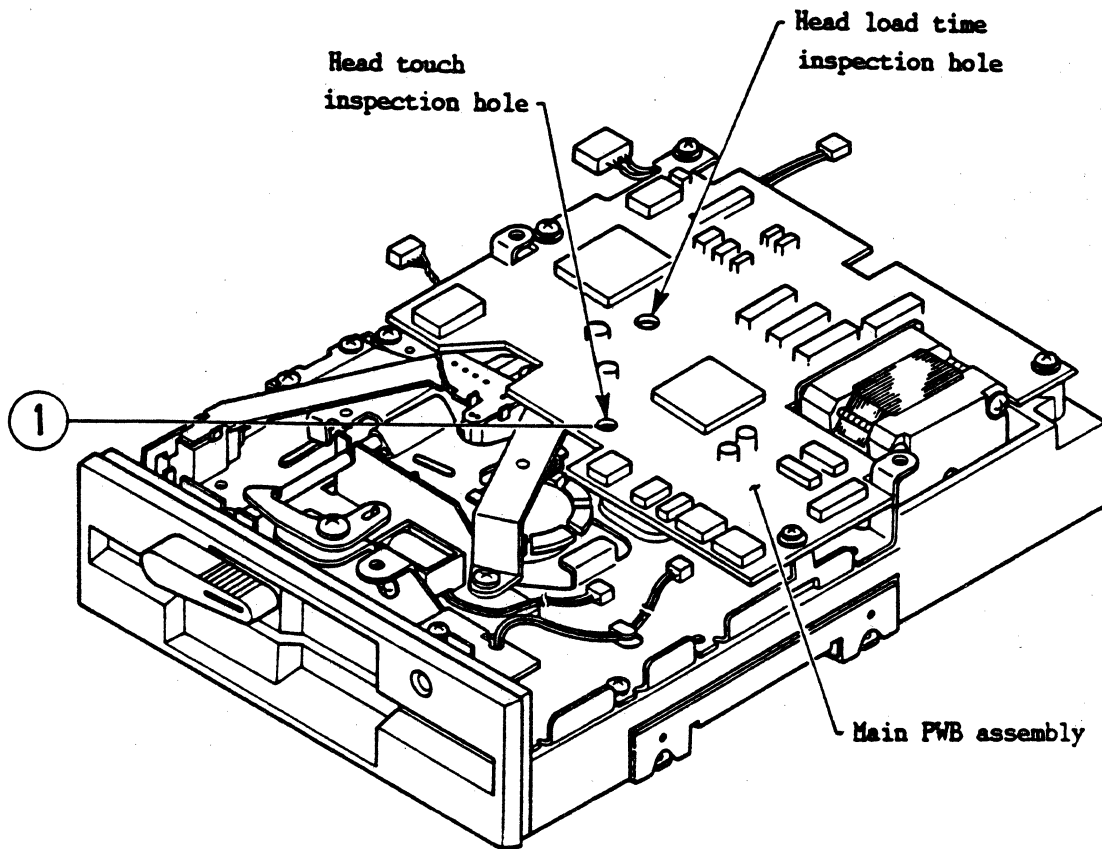

Figure 4-7 Head Contact Inspection

#### 4.4.7 Asymmetry

Tools Required: Work/Scratch Diskette  
Exerciser (AVA 409 or equivalent)  
Oscilloscope

Proceed as follows:

1. Connect the oscilloscope to the READ DATA interface signal (pin-30). Set the oscilloscope range to DC mode, 2 Volts per division, and 1 microsecond per division time base.
2. Start the Spindle Motor and load the diskette.
3. Seek the Read/Write head to the innermost track.
4. Record and then read a constant "1F" on the entire track (1F is a 0's only WRITE DATA frequency of 125kHz for M2552K and 250kHz for M2553/54K).
5. Measure asymmetry as shown in Figure 4-8.

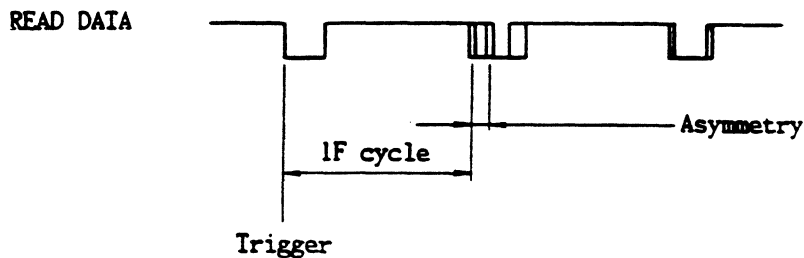

Figure 4-8 Asymmetry Measurement

**Note:** Set the oscilloscope so 3 read data pulses can be observed and measured on the screen, as shown in Figure 4-8.

6. At the innermost track, ensure the asymmetry is 600 nanoseconds or less for the M2552K or 300 nanoseconds or less for the M2553/54K.
7. Repeat steps 4 through 6 for side 0 and side 1.
8. If asymmetry standards are not met, the following items are probable causes.
  - (a) A high concentration of magnetic flux may be near the Disk Drive. If there is a magnet, transformer, motor, CRT or other source of magnetism near the drive, move it and repeat the asymmetry measurement.
  - (b) The diskette may be faulty. Replace the diskette and repeat.
  - (c) The Read/Write head may be faulty. Replace the head carriage assembly (refer to paragraph 4.5.1).
  - (d) The main circuit card may be faulty. Replace the main circuit card (refer to paragraph 4.5.6).

#### 4.4.8 Read Level

Tools Required: Work Diskette  
Exerciser (AVA 409 or equivalent)  
Oscilloscope

Proceed as follows:

1. Connect the oscilloscope channels to TP1 and TP2. Set the oscilloscope to AC mode, both channels to 0.2 volts per division, and 1 microsecond per division time base.  
Put one of the channels in invert mode, and put both channels to ADD.
2. Start the Spindle Motor and load the level diskette.
3. Seek the Read/Write heads to the innermost track.
4. Record and then read a constant "2F" on the entire track (2F is a 1's only WRITE DATA frequency of 250kHz for M2552K and 500kHz for M2553/54K).
5. Measure the average Read Level value ( $V_{p-p}$ ), refer to Figure 4-9.

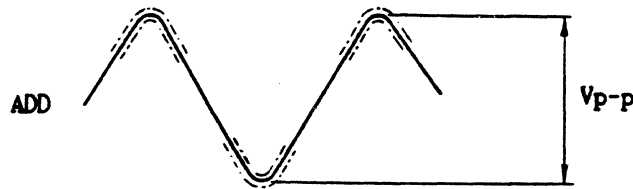

Figure 4-9 Average Read Level Measurement (2F)

6. Ensure the Read Level (true value) is within the range shown below:  
Innermost track Read Level = 200mvp-p or more (all M225XK Models).
7. Repeat steps 4 through 6 for side 0 and side 1.
8. If the results are not within the indicated range, the following items are probable causes:
  - (a) Faulty diskette. Replace the diskette if it is bent or damaged.
  - (b) Abnormal disk speed. Refer to paragraph 4.4.5.
  - (c) Faulty head contact. Refer to paragraph 4.4.6.
  - (d) Faulty Read/Write head. Refer to paragraph 4.5.1.
  - (e) Faulty circuit card. Refer to paragraph 4.5.6.



#### 4.4.9 Resolution

Tools Required: Work Disk  
Exerciser (AVA 409 or equivalent)  
Oscilloscope

1. Connect the oscilloscope channels to TP1 and TP2. Set the oscilloscope to AC mode, both channels to 50 millivolts per division, and 1 microsecond per division time base.  
Put one of the channels in invert mode, and put both channels to ADD.
2. Start the Spindle Motor and load the level disk.
3. Seek the Read/Write heads to the innermost track.
4. Record and then read the innermost track with a constant "1F" (WRITE DATA frequency with only 0's recorded of 125kHz for the M2552K and 250kHz for the M2553/54K).
5. Measure the average read level (shown as V1F in Figure 4-10).
6. Record and then read the innermost track with a constant "2F" (WRITE DATA frequency with only 1's recorded is 250kHz for the M2552K and 500kHz for the M2553/54K - double the 1F of step 4).
7. Measure the average read level (shown as V2F in Figure 4-10).

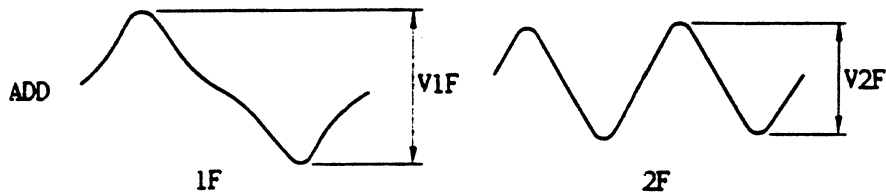

Figure 4-10 Resolution Measurement

8. Use the measured values of V1F and V2F in the following formula:  
$$\text{Resolution (true value)} = \frac{V2F}{V1F} \times 100$$
9. Ensure the innermost track Resolution (true value) is 60% or more.
10. Repeat steps 4 through 9 for side 0 and side 1.
11. If the results are not within the indicated range, the following items are probable causes:
  - (a) Faulty Diskette. Replace the diskette if it is bent or damaged.
  - (b) Abnormal disk speed. Refer to paragraph 4.4.5.
  - (c) Faulty head contact. Refer to paragraph 4.4.6.
  - (d) Faulty head. Refer to paragraph 4.5.1.
  - (e) Faulty circuit card. Refer to paragraph 4.5.6.

#### 4.4.10 Track Alignment

**Tools Required:** Phillips Screwdriver, M3  
Alignment Disk  
Flat Blade Screwdriver, medium  
Exerciser (AVA 409 or equivalent)  
Oscilloscope  
Intraconnector 34-pin  
Relative Humidity Meter  
Screw Lock Liquid

**Note:** Perform track alignment inspection and adjustment at normal room temperature and humidity. Avoid extremely low temperatures or extremely low or high humidities (even if the Disk Drive is normally used under these conditions). Place the Disk drive and disk in a normal environment for 2 hours before starting the following procedure.

When inspecting the alignment, place the Disk Drive in the position in which it is normally used (horizontal or vertical).

Proceed as follows:

1. Connect the oscilloscope channels to TP4 and TP5. Set the oscilloscope to AC mode, with both channels to 0.5 volts per division, Set the time base at 20 milliseconds per division. Put one of the channels in invert mode, and put both channels to ADD. Connect the trigger input to pin-8 of the intraconnector (between the drive and exerciser).
2. Start the Spindle Motor and load the alignment diskette.
3. Seek the Read/Write heads to Track 32, from track 0 (outermost track).
4. Check for a pattern of two lobes (VA and VB levels need not coincide).

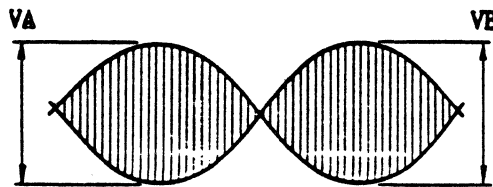

**Figure 4-11 Lobe Pattern for Track Alignment**

- a. If only one lobe pattern is observed, or when the two lobe patterns are connected, the head is off-track. In this case proceed to the alignment procedure given in step 5 below.
- b. If lobes VA and VB are within 20% of each other then seek the heads inward 4 tracks (track 36) then outward 4 tracks (track 32).

**Note:** The percentage of lobe VA to VB is measured by adjusting the variable gain on channels A and B until the larger lobe is 5 divisions in amplitude. The lobes are then compared and should be within 1 division of each other (each full division is equal to 20%, and each of the minor divisions are equal to 4%).

- c. If head alignment is within 20% (after the 4 track move in/out) select the other head and repeat procedure steps 1 through 4, then proceed to paragraph 4.4.11.
5. Adjust track alignment, using the following procedure, if the Alignment Error is greater than 20% as described above in step 4. Refer to Figure 4-12.
  - (a) Slightly loosen the screws holding the stepping motor.
  - (b) Push the tip of a screwdriver into the tooth in the stepping motor (from the rear of the Disk drive).
  - (c) Move the stepping motor only slightly, and then step the Read/Write heads several tracks in and out, until the Alignment Error is minimum.
  - (d) The adjustment should be made to minimize the Alignment Error for both side 0 and side 1.
6. Tighten the 2 screws for the stepping motor in sequence a little at a time and repeat the adjustment (if required) until the Alignment Error is less than  $\pm 20\%$  (see step 4 for how to measure this 20%), when the screws are tightened to the specified torque of 20 inch pounds (9 kilograms cm).
9. Remove the alignment disk and apply screw lock liquid to the heads of the stepping motor mounting screws.
10. Inspect and adjust Track 00 sensor (refer to paragraph 4.4.11).

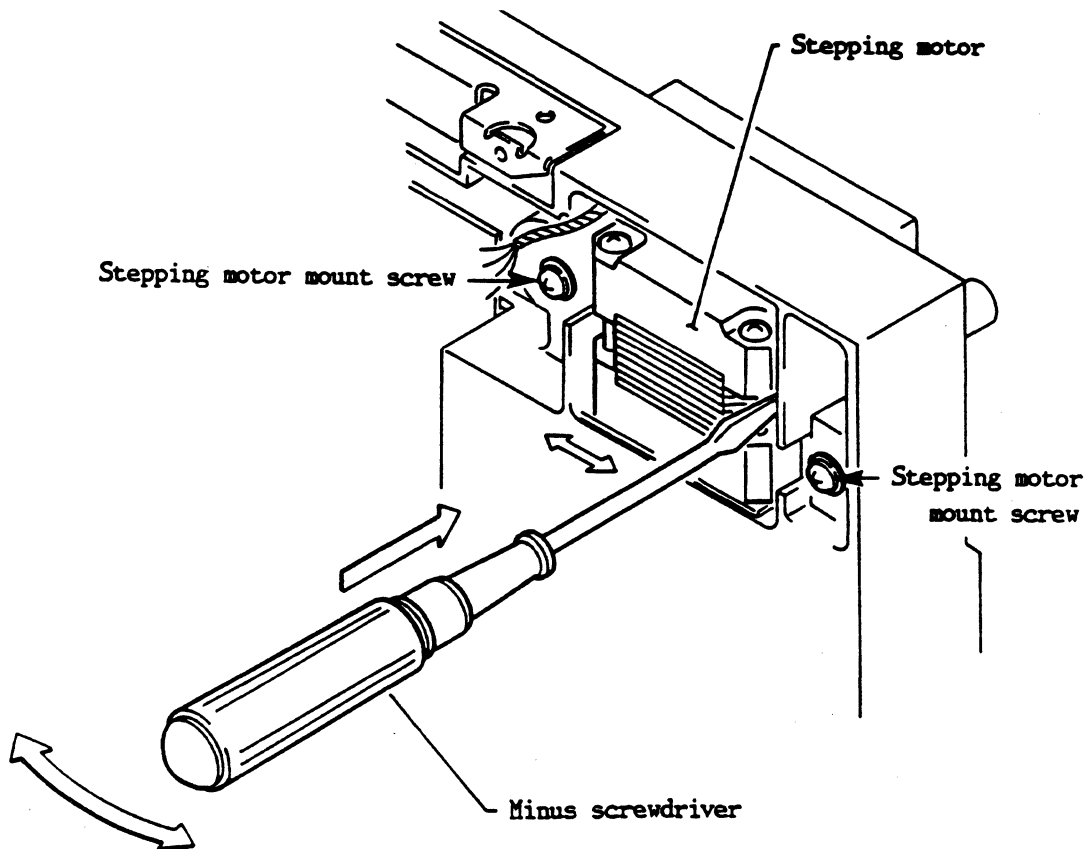

Figure 4-12 Track Alignment Adjustment

#### 4.4.11 Track 00 Sensor Inspection and Adjustment

Tools Required: Phillips Screwdriver, M3  
Work/Scratch Diskette  
Alignment Disk  
Exerciser (AVA 409 or equivalent)  
Oscilloscope  
Screw Lock Liquid  
Intraconnector 34-pin

Proceed as follows:

1. Connect the oscilloscope to TP7 (Track 00 Sensor). Set the oscilloscope to DC mode, 1.0 volt per division.
2. Start the Spindle Motor and load the work/scratch diskette.
3. Ensure the voltage at TP7 is 0.5 Volts or less with the Read/Write heads located at Track 00.
4. Seek the Read/Write heads to track 02.
5. Ensure the voltage at TP7 is 3.0 Volts or more with the Read/Write heads located away from Track 00 (track 02).
6. If the voltages, measured in steps 3 and 5, are not within the specified range, adjust the Track 00 sensor position as follows.
7. Connect the oscilloscope's vertical input to TP1 or TP2 (pre-amp).  
Connect the Trigger to pin-8 of the Intraconnector (Index).  
Set the oscilloscope to AC mode, 0.2 Volts per division, and invert channel B.  
Set Time Base to 20 milliseconds per division.
8. Insert the alignment diskette.
9. Seek the Read/Write heads to the alignment track, where the lobe pattern shown in Figure 4-11 is observed (Track Alignment must be correct before proceeding, refer to paragraph 4.4.10).
10. Connect the oscilloscope to TP7 (Track 00 Sensor) and set the oscilloscope to DC mode, 1.0 volt per division.
11. Seek the Read/Write heads to track 02.

#### 4.4.11 Track 00 Sensor Inspection and Adjustment (Continued)

12. Loosen the Track 00 sensor mounting screw and move the sensor backward and forward (refer to Figure 4-13).

Adjust the sensor to the intermediate point, where TP7 voltage changes from approximately 0.5 Volts to 3.0 Volts and then tighten the mounting screw.

**Note:** Move the sensor cautiously - Track 00 output voltage changes suddenly.

13. Check steps 3 through 5.
14. Repeat the adjustment until the values in steps 12 and 13 are within the specified range, after tightening the mounting screw to the specified torque.
15. Apply screw lock liquid to the head of the mounting screw.

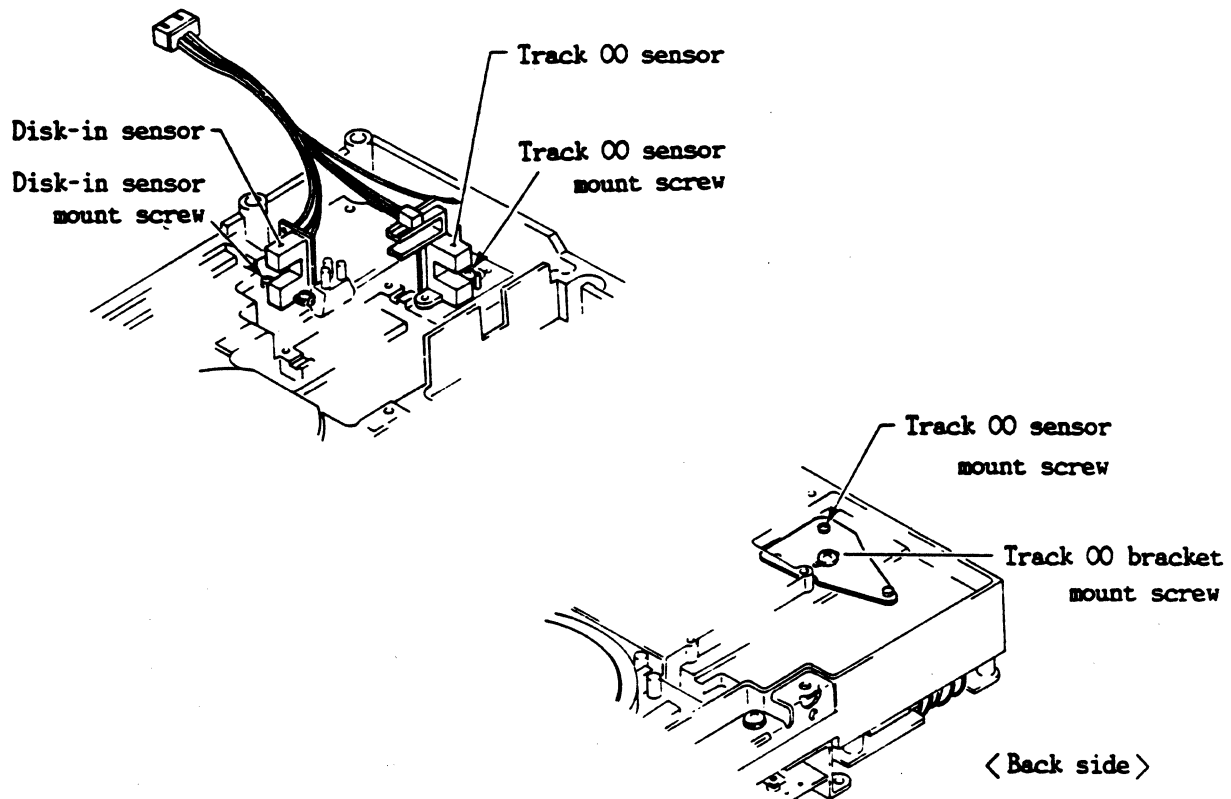

Figure 4-13 Track 00 Sensor Adjustment.

#### 4.4.12 Index Burst Timing Inspection and Adjustment

Tools Required: Phillips Screwdriver, M3  
Alignment Disk  
Exerciser (AVA 409 or equivalent)  
Oscilloscope  
Screw Lock Liquid  
Intraconnector 34-pin

Refer to Figure 4-14.

1. Set the oscilloscope as follows:
  - Channel 1: Connect to TP1 (pre-amp), AC mode, 0.2V per division.
  - Channel 2: Connect to TP2 (pre-amp), AC mode, 0.2V per division.
  - Time Base: Set to 50 microseconds per division.
  - Trigger: Connect to pin 8 or intraconnector (Index), DC mode.Set Trigger mode to External, on the negative edge (this will start the sweep at the beginning of each disk rotation).
2. Start the Spindle Motor and load the alignment disk.
3. Seek the Read/Write heads to Track 02.
4. Measure the duration of "t" in Figure 4-14.

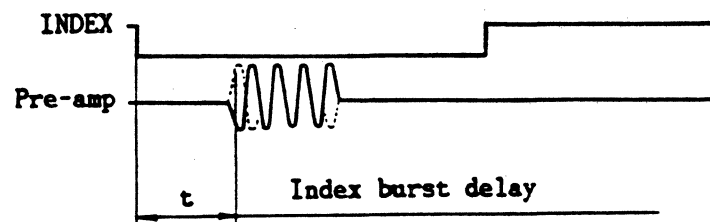

Figure 4-14 Index Burst Timing

5. Ensure that Index Burst Timing is within the range of  $200 \pm 150$  microseconds, for all models in the M255XK family. Switch heads and reverify timing.
6. Seek the read/write heads to track 68. Verify the Index Burst timing is still within specifications. Switch heads and reverify timing.
7. If the timing at either track 2 or track 68, head 0 or head 1, is outside of specifications, proceed to step 8 and adjust the Index Sensor to achieve a balance point between the four locations (tracks 2 and 68, heads 0 and 1).

#### 4.4.12 Index Burst Timing Inspection and Adjustment (Continued)

8. If Index Burst Timing is not within the range specified in step 6, adjust the Index Sensor as follows:
  - (a) Refer to Figure 4-15. Loosen the Index sensor mounting screw and move the sensor until the True Index Burst Timing is within the specified range given in step 6.
  - (b) After tightening the mounting screw, to the specified torque, repeat the adjustment until the True Index Burst Timing is within the specified range.
  - (c) Coat the head of the mounting screw with a small quantity of screw lock liquid.
9. Remove the alignment disk.

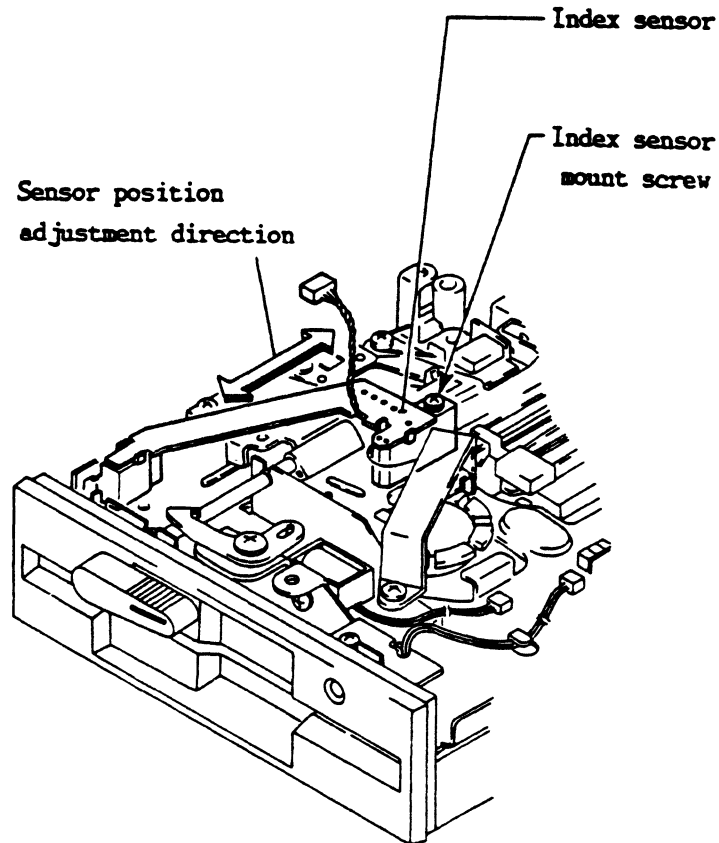

Figure 4-15 Index Sensor Adjustment

#### 4.4.13 Head Load Inspection and Adjustment

Tools Required: Phillips Screwdriver, M3  
Allen Wrench, 1.5mm  
Oscilloscope  
Scratch/Work Disk  
Exerciser (AVA 409 or equivalent)  
Screw Lock Liquid  
Intraconnector 34-pin

1. Set the Head Load jumper selection to HS and set Drive Select to DS0, refer to Figure 4-1, Table 4-5.
2. Set the oscilloscope as follows:  
Channel 1: Connect to TP4, AC mode, 0.2V  
Channel 2: Connect to TP5, AC mode, 0.2V  
Trigger: Connect to pin-4 of intraconnector  
Set Trigger mode to External, on the negative edge
3. Start the Spindle Motor and load the alignment disk.
4. Record a pattern of 1F (all zero's) on Track 04 (Write Data frequency of 125kHz for the M2552K and 500kHz for the M2553/54K).
5. Adjust Channel 2 output waveform, using the oscilloscope's ranges and variable gain controls, until the amplitude of Level "A" as shown in Figure 4-16 is equal to 5 divisions.

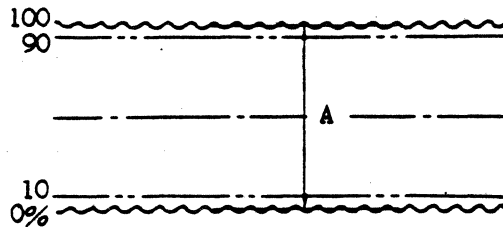

Figure 4-16 Head Load Signal "A"

6. Refer to Figure 4-17. While selecting and deselecting the drive, measure the time from head unload to head load. Ensure that the time, from scope trigger to 90% of maximum amplitude (Level "B") is less than 50 milliseconds.

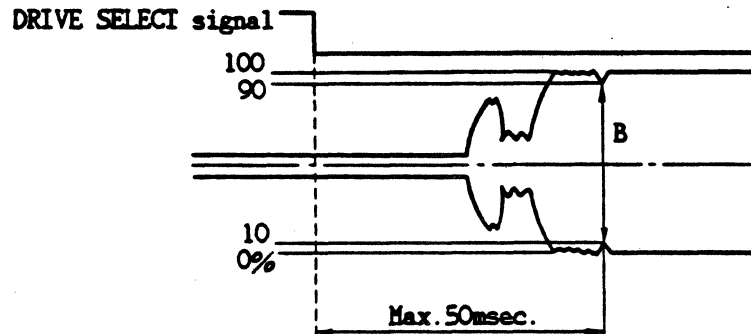

Figure 4-17 Head Load Interval and Signal "B"



7. If the Head Load Interval is greater than 50 milliseconds, adjust the head height using the 1.5mm Allen wrench, as shown in Figure 4-18 below, and repeat steps 5 and 6.
8. Seek the heads to Track 79 and repeat steps 4, 5 and 6.

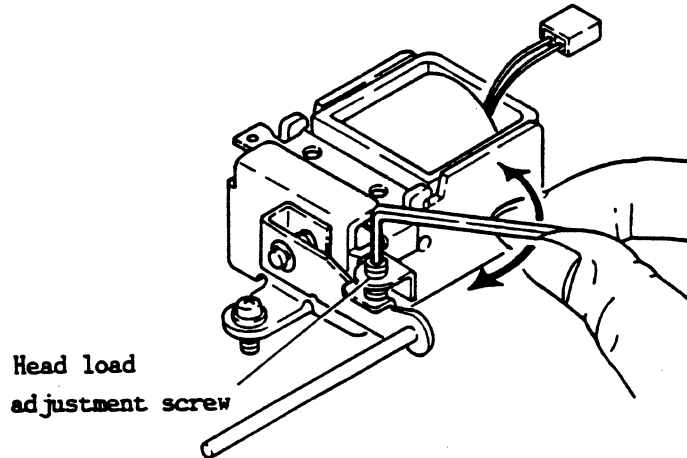

Figure 4-18 Head Load Adjustment Screw

After completing the above procedures check the unload level as follows:

9. Use the oscilloscope to measure Channel 2 output waveform "A" with the disk drive selected, refer to Figure 4-19.

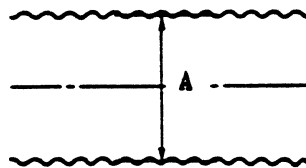

Figure 4-19 Head Unload Signal "A"

10. Use the oscilloscope to measure Channel 2 output waveform "B" with the disk drive deselected, refer to Figure 4-20.

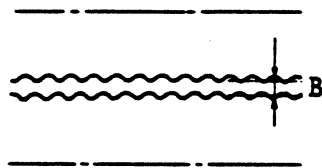

Figure 4-20 Head Unload Signal "B"

11. Check that  $B/A \times 100 (\%)$  is within the specified range, repeat for Track 79.
12. If the head load or unload level is out of specification (see Figure 4-17), readjust the Head Load Adjustment Screw (see step 7 above) and then repeat steps 4 through 11 as required.
13. Coat the head of the adjustment screw with screw lock and return the HS jumper to its original position.

#### 4.4.14 Door Lock Inspection

Tools Required: Phillips Screwdriver, M3  
Scratch/Work Disk  
Exerciser (AVA 409 or equivalent)

1. Set Drive Select to DS0, refer to Figure 4-1, Table 4-5.
2. Refer to Figure 4-21. Select the disk drive, with the front level released, to activate the door lock solenoid and lock the door.

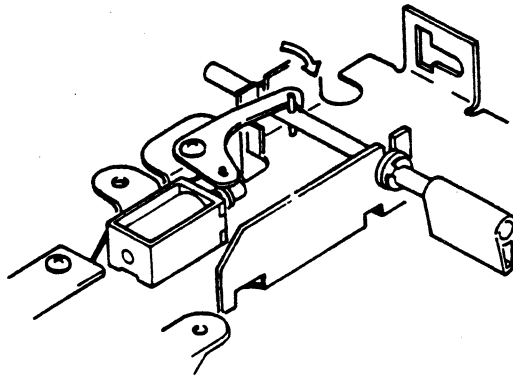

Figure 4-21 Door Lock Solenoid Activated

3. Refer to Figure 4-22. Deselect the disk drive. Ensure that the door lock solenoid is deactivated and the the door is released.

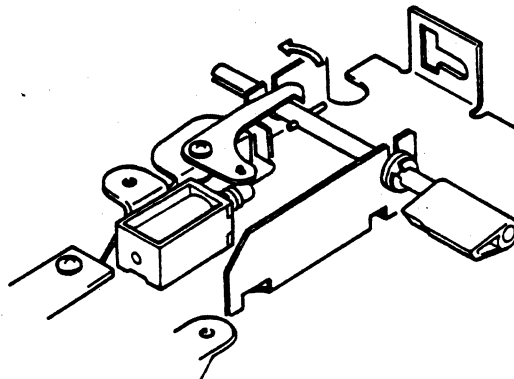

Figure 4-22 Door Lock Solenoid Deactivated

4. Select and deselect the drive several times to ensure that the door lock solenoid and stopper pin operate correctly.

## 4.5 REMOVAL AND REPLACEMENT PROCEDURES

The following step-by-step procedures explain the removal and replacement of assemblies within the disk drive.

### 4.5.1 Head Carriage Replacement

Tools Required: Phillips Screwdriver, M3  
Phillips Screwdriver, M2.6  
Tweezers  
Alcohol and Gauze  
Screw Lock Liquid

Figure 4-23 is an overview drawing and Figure 4-24 shows Head Cable Routing.

1. Remove the cover screws and the shield cover (Figure 5-5, item 44).
2. Remove the mounting screws and lift up the main circuit card assembly (Figure 5-5, item 43).
3. Disconnect all cable connectors at the main circuit card and remove the card.
4. Remove the head cable from its cable clamp, refer to Figure 4-25A through 4-25C.
5. Remove the two mounting screws and take out the Bail Assembly (Figure 5-5, item 22). Fasten the Bail Assembly with a felt pad so it does not contact the upper or lower read/write head.
6. There are two fixing plates connecting the head carriage assembly and the steel band assembly. Grasp fixing plate B (Figure 5-5, item 12) and the head carriage (Figure 5-5, item 7) with your fingers and push to disengage the steel band from band fixing plate B
7. Detach fixing plate B and the steel band spring (Figure 5-5, item 13) from the head carriage and remove them at the same time.
8. Remove the pulley screw (Figure 5-5, item S6) from the stepping motor, remove the band washer (Figure 5-5, item 14) and then the steel band.
9. Remove the 4 mounting screws and the guide shaft clips (Figure 5-5, item 10) that are holding the two guide shafts (Figure 5-5, items 8 and 9) in place, and then remove the guide shafts.
10. Prepare the new head carriage assembly and the two new guide shafts.  
  
The guide shafts and head carriage assembly must always be replaced as a single assembly.
11. Fit the guide shafts into their grooves on the chassis, using the guide shaft clips.
12. Install the head carriage assembly by reversing step 9.

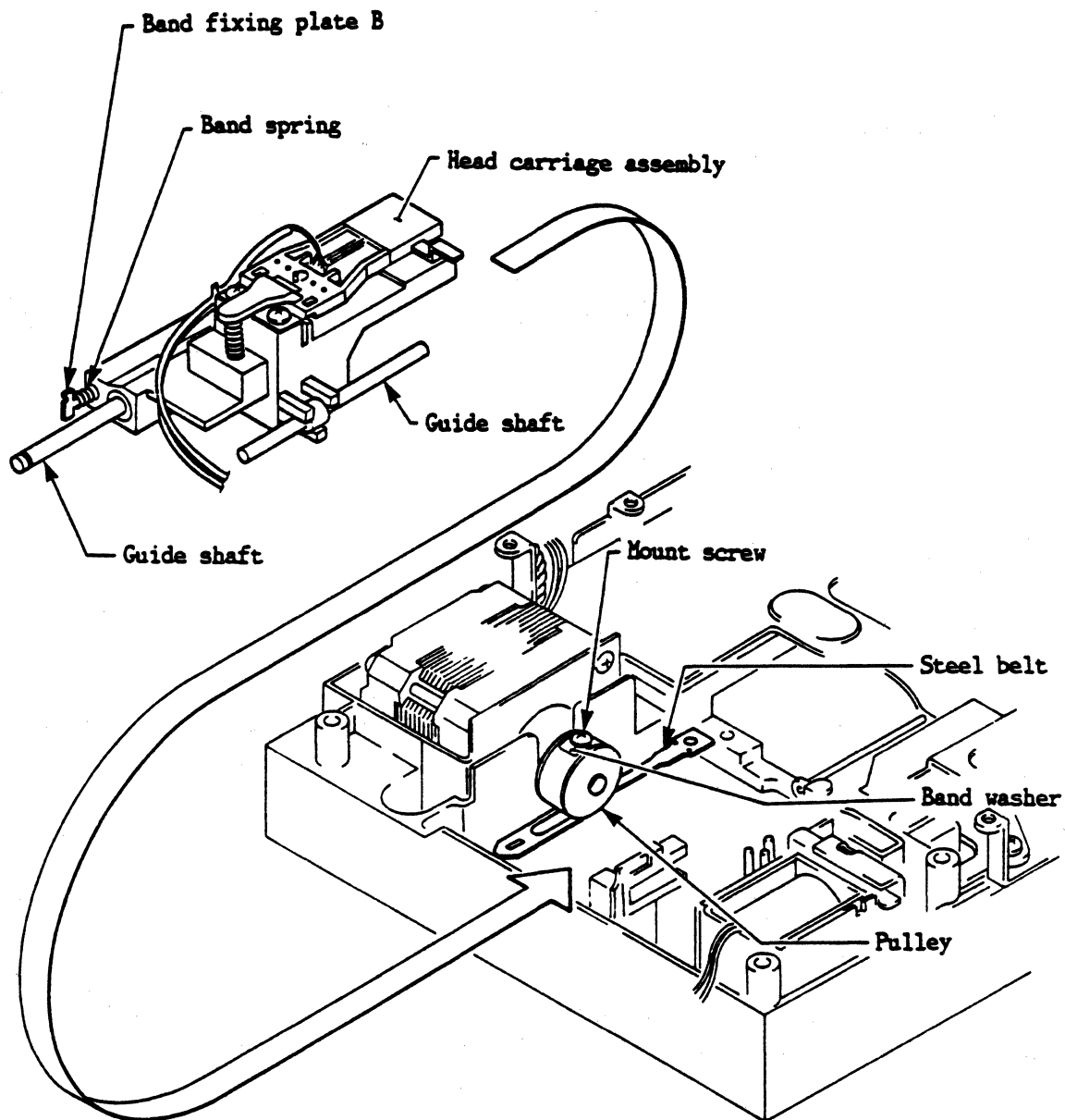

**Figure 4-23 Head Carriage Assembly Replacement**

**4.5.1 Head Carriage Replacement (Continued)**

13. Reverse the procedure described in step 8 and reinstall the steel band in the pulley section of the stepping motor.

**Note:** Carefully clean the surfaces of the steel band, pulley and other mechanisms with alcohol and gauze before assembly.

14. Reverse the procedures described in steps 6 and 7 to reconnect the steel band to the head carriage assembly (use band fixing plate B and the band spring).

15. Temporarily fasten the screws that hold the steel band in the pulley section of the stepping motor.
16. After moving the head carriage manually several times, carefully tighten the steel band fastening screws to the specified torque. The band must be tensioned so that it is perfectly straight. Be careful not to scratch the surface of the band or pulley.
17. Refer to Figure 4-24. Carefully route the head cable and install the Main Circuit card and its shield plate
18. Move the head carriage between the innermost track and Track 00 to ensure that the steel band stays straight and that there is no abnormal noise.
19. Inspect head contact (paragraph 4.4.6).
20. Inspect asymmetry (paragraph 4.4.7).
21. Adjust track alignment (paragraph 4.4.10).
22. Adjust Track 00 sensor (paragraph 4.4.11).
23. Adjust Index Burst Timing (paragraph 4.4.12).
24. Check Read Level (paragraph 4.4.8).
25. Check Read Resolution (paragraph 4.4.9).
26. Install the shield cover (see step 1).
27. Connect the Disk Drive to the user's system and perform an overall test.

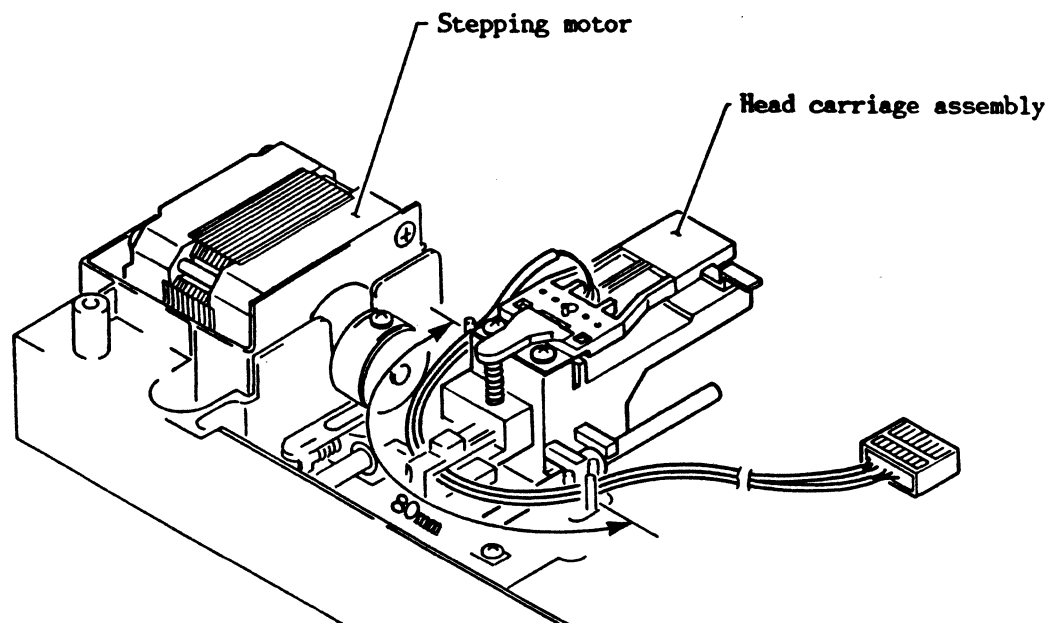

Figure 4-24A Head Cable Routing

### 4.5.1 Head Carriage Replacement (Continued)

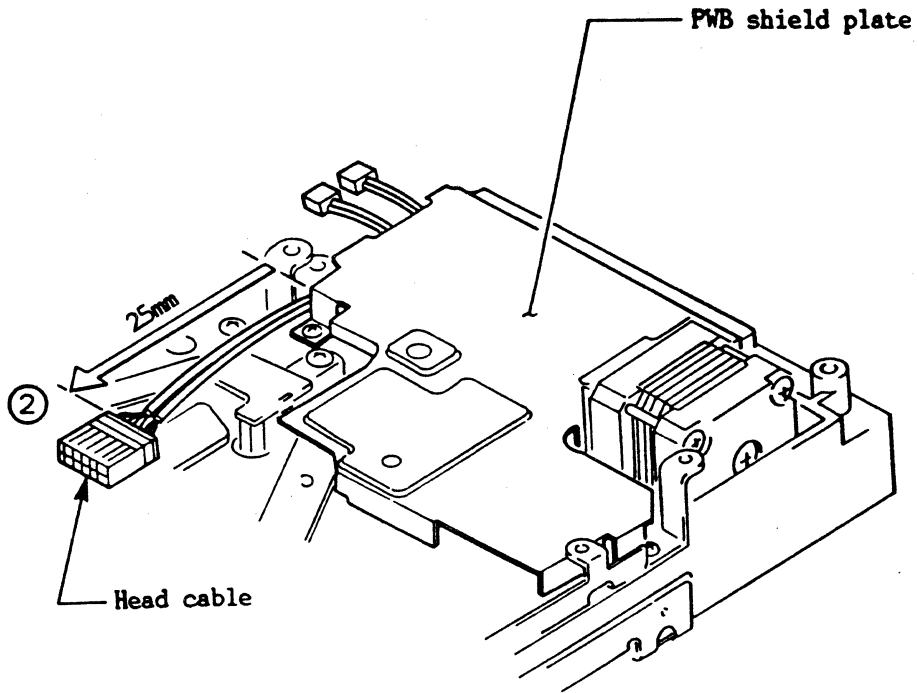

Figure 4-24B Head Cable Routing

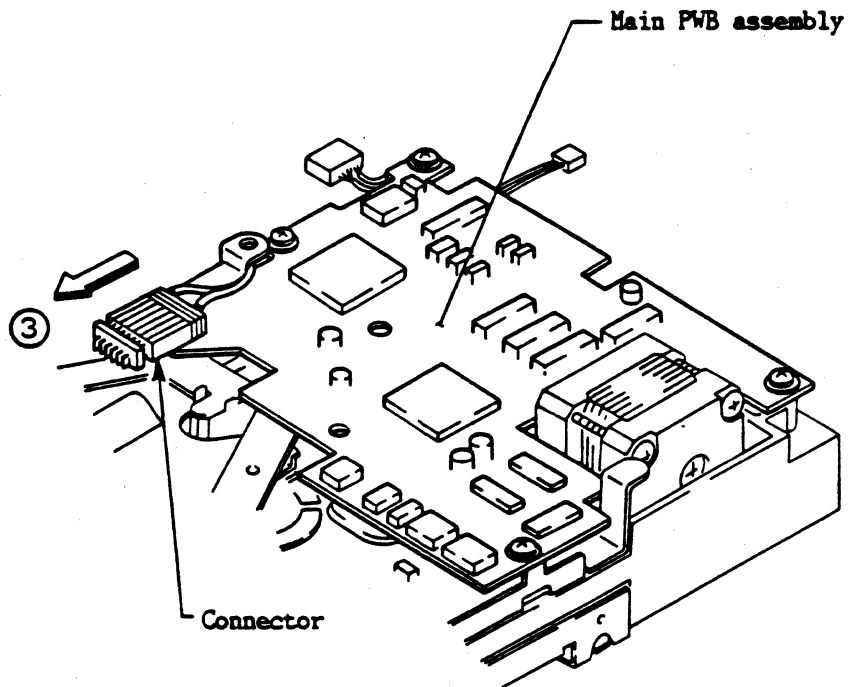

Figure 4-24C Head Cable Routing

#### 4.5.2 Stepping Motor and Steel Band Replacement

Tools Required: Phillips Screwdriver, M3  
Phillips Screwdriver, M2.6  
Allen Wrench, 1.5mm  
Tweezers  
Alcohol and Gauze  
Screw Lock Liquid  
Exerciser (AVA 409 or equivalent)

Refer to Figure 5-5.

1. Remove the shield cover assembly (item 44).
2. Remove the mounting screws from the main circuit card and lift up the circuit card (item 43).
3. Unplug all connectors at the main circuit card assembly and remove the card.
4. Remove the screws holding the main circuit card shield plate and remove the plate (item 23).
5. The head carriage assembly (item 7) and steel band (item 11) are connected by two fixing plates (A and B). Press fixing plate B (item 12) and the lower head carriage to relieve the tension, and detach the steel band from fixing plate B.
6. Remove fixing plates, A and B, and the band spring (item 13) from the head carriage assembly.
7. Remove the mounting screws for the stepping motor pulley (item 3), then remove the band washer and steel band.
8. Remove the stepper motor mounting screws.
9. Remove the screw fastening the STM bracket (item 4) - the STM bracket holds the stepping motor - and then remove the stepping motor.
10. Insert the new stepping motor and hold it in place with its mounting screws.

**Note:** When replacing the stepping motor, the steel band and the band spring must also be replaced.

11. Temporarily coil the new steel band to the stepping motor pulley, and install the stepping motor with the band washer and head carriage.
12. Connect the steel band and head carriage - with band fixing plates A and B - by reversing the procedures described in steps 5 and 6.
13. Move the head carriage manually, then tighten the steel band mounting screws to the specified torque. The band must have tension and remain perfectly straight. Use care to keep the surfaces of the band and pulley clean.
14. Install the main circuit card shield plate, by reversing the procedure described in step 4.

#### 4.5.2 Stepping Motor and Steel Band Replacement (Continued)

15. Install the main circuit card by reversing steps 2 and 3.
16. With the exerciser, seek between Track 00 and the innermost track and ensure the steel band stays straight. If the band does not stay straight, shut off the unit and readjust the band. After each adjustment of the band, tighten the holding screw to the specified torque.
17. Adjust track alignment (paragraph 4.4.10).
18. Adjust Track 00 sensor (paragraph 4.4.11).
19. Install the shield cover assembly.

#### 4.5.3 Spindle Motor Replacement

Tools Required: Phillips Screwdriver, M3  
Tweezers  
Wire Cutters

Refer to Figure 5-5.

1. Remove the shield cover (item 44).
2. Remove the mounting screws from the main circuit card and lift up the circuit card (item 43), unplug all connectors at the main circuit card assembly and remove the card.
3. Remove the screws holding the main circuit card shield plate and remove the plate (item 23).
4. Remove the three spindle motor mounting screws (from the spindle side) and remove the spindle motor from the rotor (circuit card) side.
5. Carefully insert the new spindle motor into the chassis, install a new spindle motor by reversing the procedures described in steps 2 through 5. Ensure the new spindle is parallel to the chassis.

**Note:** Use extreme caution to avoid scratching the surfaces of the spindle.

6. Adjust the collet assembly (paragraph 4.4.1).
7. Check the write protect sensor (paragraph 4.4.4).
8. Check disk rotational speed (paragraph 4.4.5).
9. Inspect and adjust track alignment (paragraph 4.4.10).
10. Inspect and adjust Index burst timing (paragraph 4.4.13).
11. Install the shield cover assembly.



#### **4.5.4 Collet Assembly Replacement**

Tools Required: Phillips Screwdriver, M3  
Tweezers  
Screw Lock Liquid

Refer to Figure 5-5.

1. Remove the shield cover assembly (item 44).
2. Remove the two screws fastening the collet shaft plate assembly (item 30).
3. Remove the E-ring (item S17) on the collet actuating plate (item 29) and remove the collet actuating plate with its washer and pressure spring.
4. Install a new collet assembly, washer and pressure spring by reversing the removal procedures given in steps 2 and 3.
5. Adjust the position of the center of the collet assembly using the procedure described in paragraph 4.4.1 and tighten the mounting screws to the specified torque.
6. Inspect and adjust track alignment (paragraph 4.4.10).
7. Install the shield cover assembly.

#### **4.5.5 Sensor Block Replacement**

Tools Required: Phillips Screwdriver, M3  
Tweezers  
Screw Lock Liquid

Refer to Figure 5-5.

1. Remove the shield cover (item 44).
2. Remove the mounting screws from the main circuit card and lift up the circuit card (item 43), unplug all connectors at the main circuit card assembly and remove the card.
3. Remove the screws holding the main circuit card shield plate and remove the plate (item 23).
4. Remove the two screw holding the sensor block to the chassis and remove the sensor block (item 15).
5. Install a new sensor block by reversing the removal procedure.
6. Adjust the Track 00 sensor (paragraph 4.4.11).
7. Inspect and adjust track alignment (paragraph 4.4.10).

#### 4.5.6 Main Circuit Card Replacement

Tools Required: Phillips Screwdriver, M3

Refer to Figure 5-5.

1. Remove the shield cover (item 44).
2. Remove the mounting screws from the main circuit card and lift up the circuit card (item 43), unplug all connectors at the main circuit card assembly and remove the card.
3. Remove the screws holding the main circuit card shield plate and remove the plate (item 23).
4. Install a new main circuit card assembly by reversing the removal procedure given above in steps 2 and 3.

**Note:** The Main Circuit Card is available at different revision levels, obtain the correct Drawing Number from the replaced circuit card.

5. Set the circuit card selection jumpers in the same positions as they were on the removed card (refer to Figure 4-1, Table 4-5).
6. Check asymmetry (paragraph 4.4.7).
7. Check read level (paragraph 4.4.8).
8. Check read resolution (paragraph 4.4.9).
9. Check Track 00 sensor (paragraph 4.4.11).
10. Replace the shield cover assembly.
11. Connect the disk drive to the system and perform an overall test.

#### 4.5.7 Write Protect Sensor Replacement

Tools Required: Phillips Screwdriver, M3  
Screw Lock Liquid

Refer to Figure 5.5.

1. Remove the shield cover assembly (item 44).
2. Disconnect the sensor block connector (J7).
3. Remove the three mounting screws and the sensor block assembly (item 24).
4. Install the new sensor block assembly by reversing the procedures described in steps 1 through 3.
5. Adjust the new Write Protect sensor (paragraph 4.4.4).
6. Adjust Index burst timing (paragraph 4.4.12).
7. Install the shield cover assembly.

#### 4.5.8 Bezel Replacement

Tools Required: Phillips Screwdriver, M3

Refer to Figure 5-5.

1. Turn the front lever (item 42) to the open position and remove the front lever assembly (paragraph 4.5.9).
2. Remove the Bezel's mounting screws (item S13) and the Bezel (item 41) by pulling it forward.
3. Install the new Bezel by reversing the procedures given in steps 1 and 2.

**Note:** When installing the new Bezel, press both sides of the Bezel against the chassis and tighten the mounting screws to the specified torque.

#### 4.5.9 Front Lever Assembly

Tools Required: Tweezers

Refer to Figure 5-5.

1. Turn the front lever to its open position, remove the E-ring (item S17) and remove the front lever from the disk drive.
2. Install the new front lever assembly by reversing the removal procedure.

**Note:** When installing the front lever assembly, be sure to align the front lever's D hole with the clamp shaft.

#### 4.5.10 Clamp Cam Replacement

Tools Required: Phillips Screwdriver, M3  
Tweezers  
Lubricant (Nippon Koyu Ltd. H-10 or HH-17, or equivalent)

Refer to Figure 5-5.

1. Turn the front lever to its open position and remove the front lever from the disk drive (paragraph 4.5.9).
2. Remove the Bezel's screws (item S13) and then the Bezel (item 41) by pulling it forward.
3. Remove the door lock spring, remove the E-ring, and remove the clamp cam assembly (item 31).
4. Install the new clamp cam assembly by reversing the removal procedure.
5. Adjust the slack in the clamp shaft to 0.05 - 0.2mm by using washers (item S20). Coat the part that contacts the clamp cam and set arm (item 28) with lubricant.
6. Install the Bezel and Front Lever by reversing the removal procedure.

**Note:** When there is a head load mechanism, the door lock cam and door lock spring, shown in Figure 4-25, are omitted.

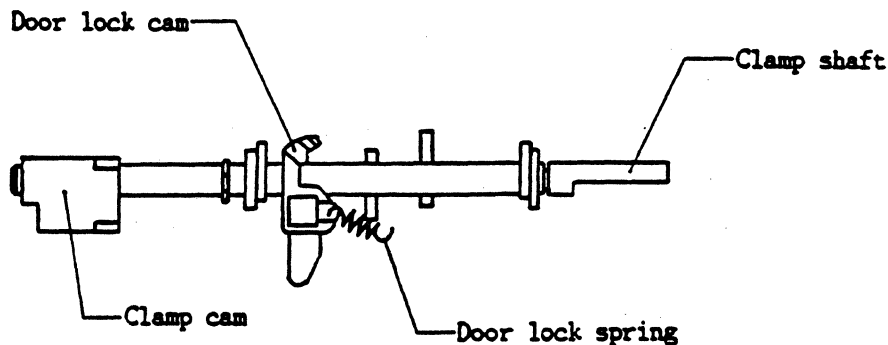

Figure 4-25 Clamp Cam Assembly

#### 4.5.11 Head Load Solenoid Replacement

Tools Required: Phillips Screwdriver, M3  
Allen Wrench, 1.5mm

Refer to Figure 5-5.

1. Remove the shield cover (item 44).
2. Remove the mounting screws from the main circuit card and lift up the circuit card (item 43), unplug all connectors at the main circuit card assembly and remove the card.
3. Remove the screws holding the main circuit card shield plate and remove the plate (item 23).
4. Remove the two screws holding the head load solenoid bracket and remove the solenoid assembly (item 32) from the chassis.
5. Install the new solenoid assembly by reversing the removal steps.
6. Refer to Figure 4-26. Use the head load adjustment screw to adjust the height of the chassis and top of the vertical rod to 0.68" (17.3mm) and temporarily tighten.
7. Adjust the head load solenoid (paragraph 4.4.13).

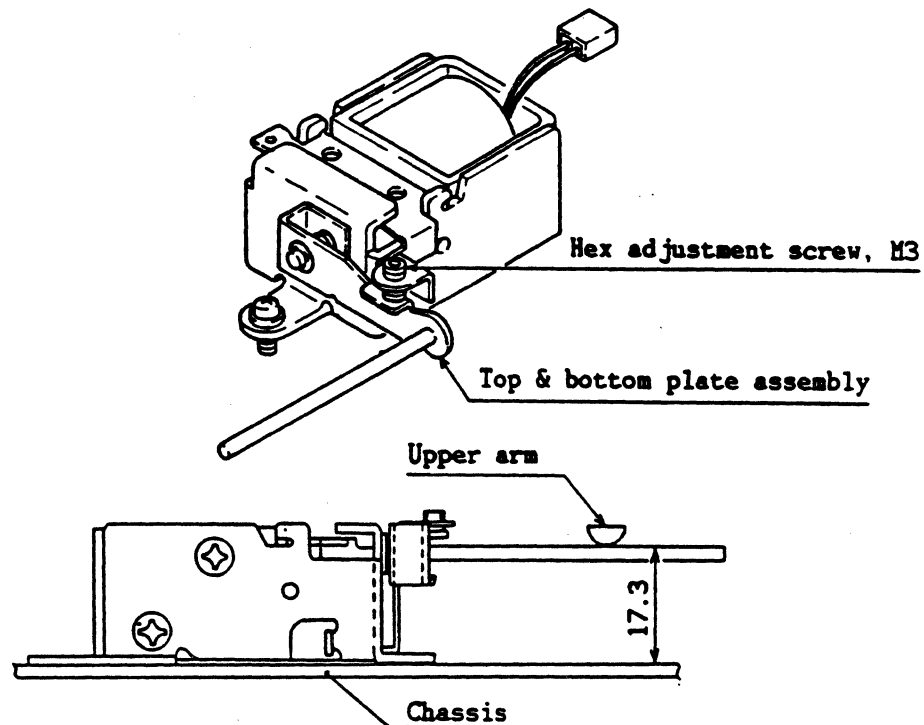

Figure 4-26 Head Load Height Adjustment

#### 4.5.12 Door Lock Solenoid Replacement

Tools Required: Phillips Screwdriver, M2  
Phillips Screwdriver, M3

Refer to Figure 5-5.

1. Remove the shield cover (item 44).
2. Open the front lever and remove the front lever assembly (paragraph 4.5.9).
3. Remove the front bezel (paragraph 4.5.8).
4. Remove the mounting screws and the door lock solenoid (item 39). Refer to Figure 4-27.
5. Install a new door lock solenoid by reversing the removal procedure.

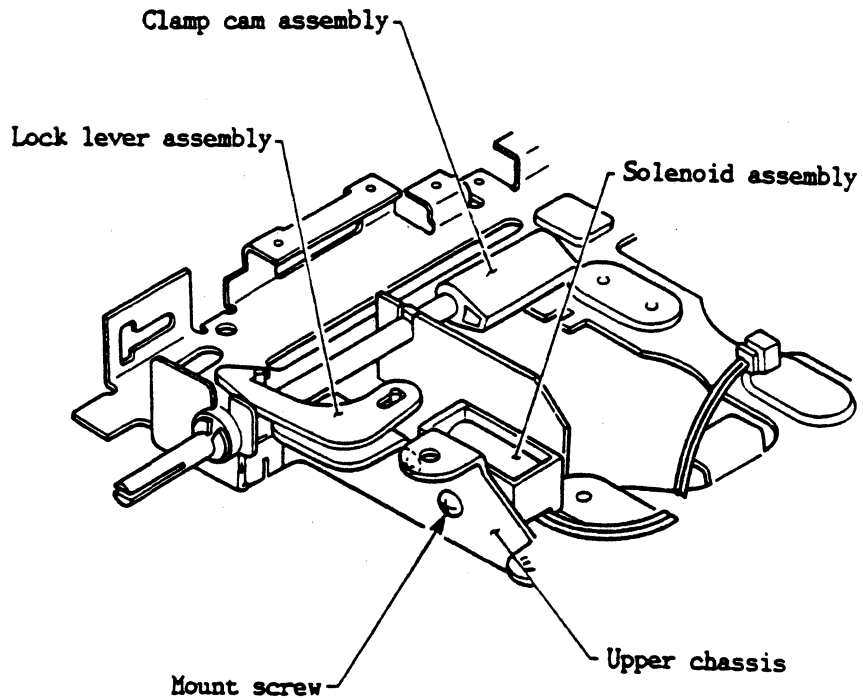

Figure 4-27 Door Lock Solenoid

**SECTION 5  
MAINTENANCE DRAWINGS AND PARTS LISTS**

**5.1 CONSTRUCTION**

As illustrated in Figures 5-1 through 5-5, M255XK Disk Drives include the major assemblies listed in Table 5-1.

**Table 5-1 M255XK Assembly Chart**

<b>Top Level</b>	<b>Intermediate Level</b>	<b>Bottom Level</b>
Disk Drive	Transport Components	Chassis Upper Chassis Assembly Spindle Motor Stepping Motor Clamp Cam Assembly Collet Assembly Track 00 Block Assembly Bail Assembly Front Bezel Front Lever Assembly Steel Band Head Load Assembly Door Lock Assembly
	Head Carriage Assembly	Read/Write Heads
	Main Circuit Card Assembly	Electronic Components
	Sensor Block Assembly	Sensors

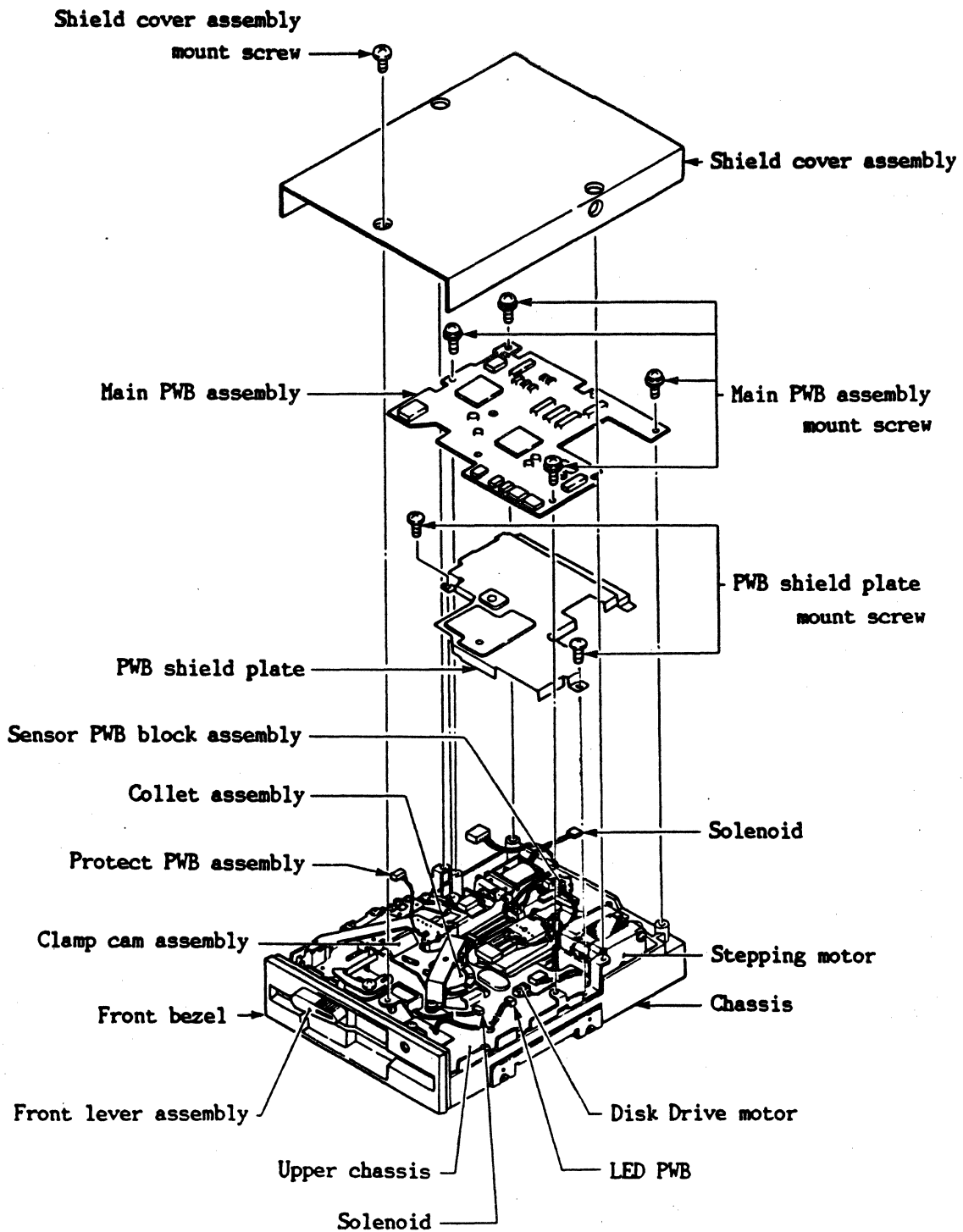

Figure 5-1 Top View of Disk Drive (View 1)



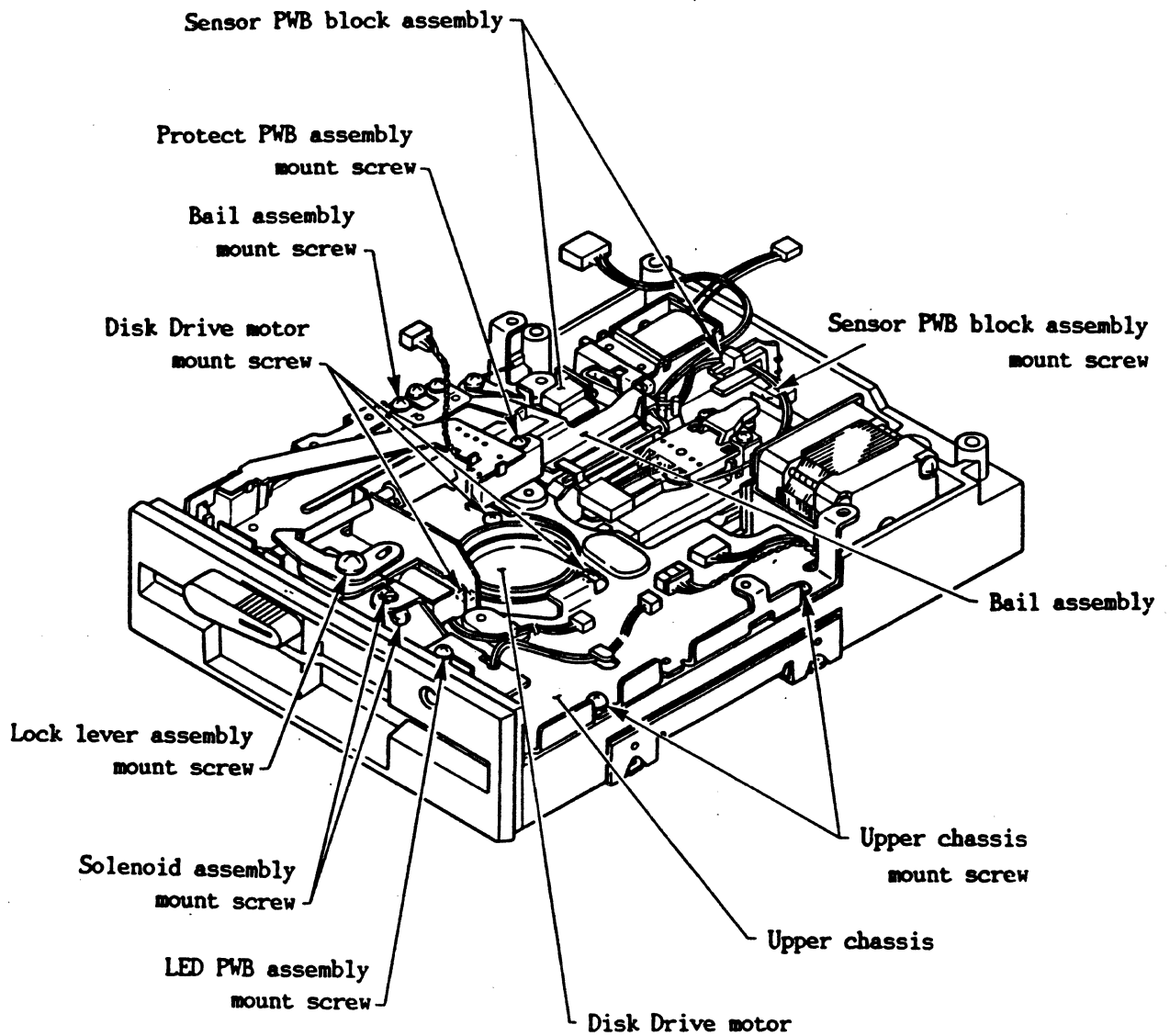

Figure 5-2 Top View of Disk Drive (View 2)

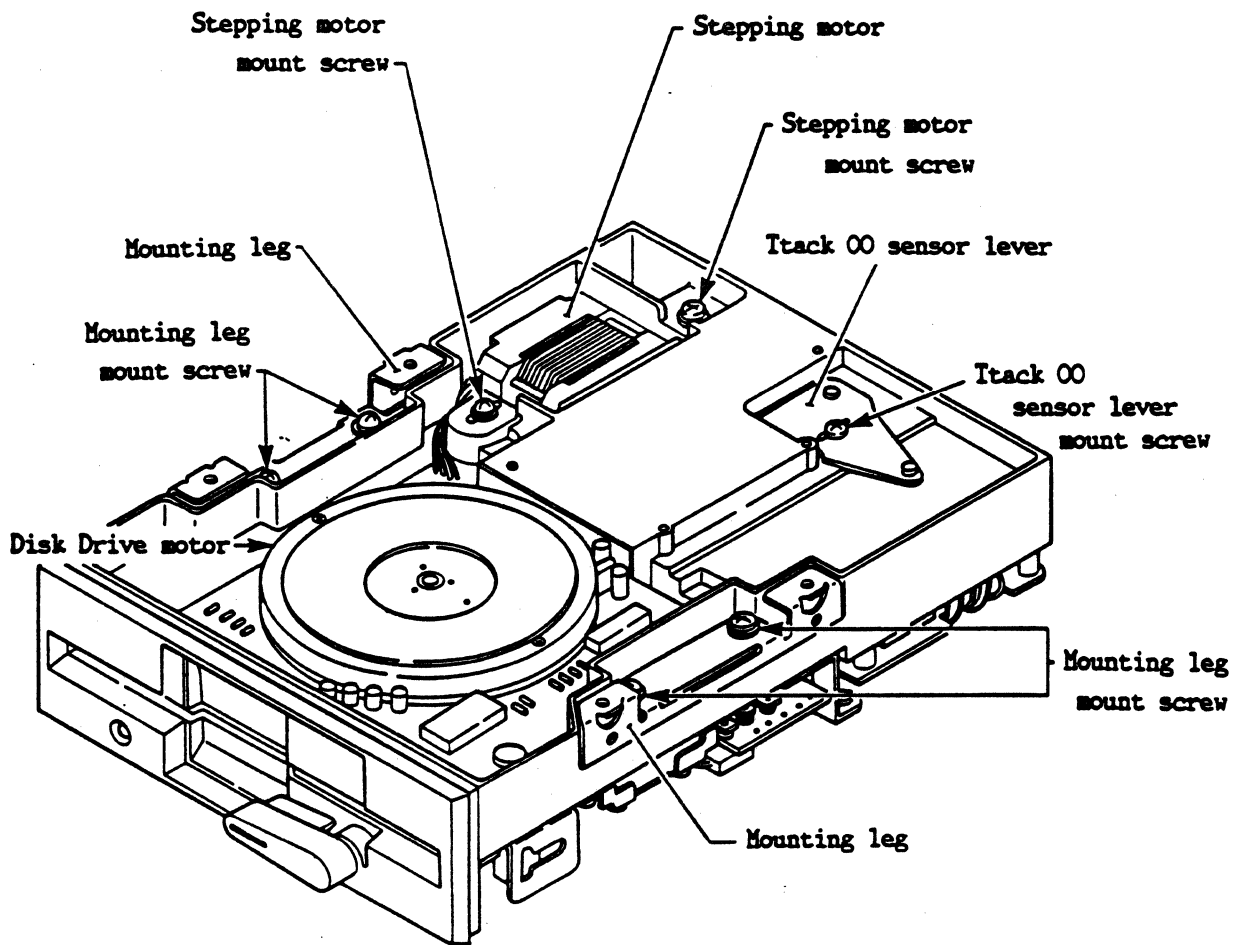

Figure 5-3 Bottom View of Disk Drive

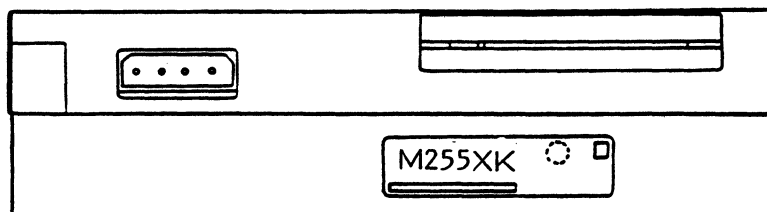

Figure 5-4 Rear View of M255XK

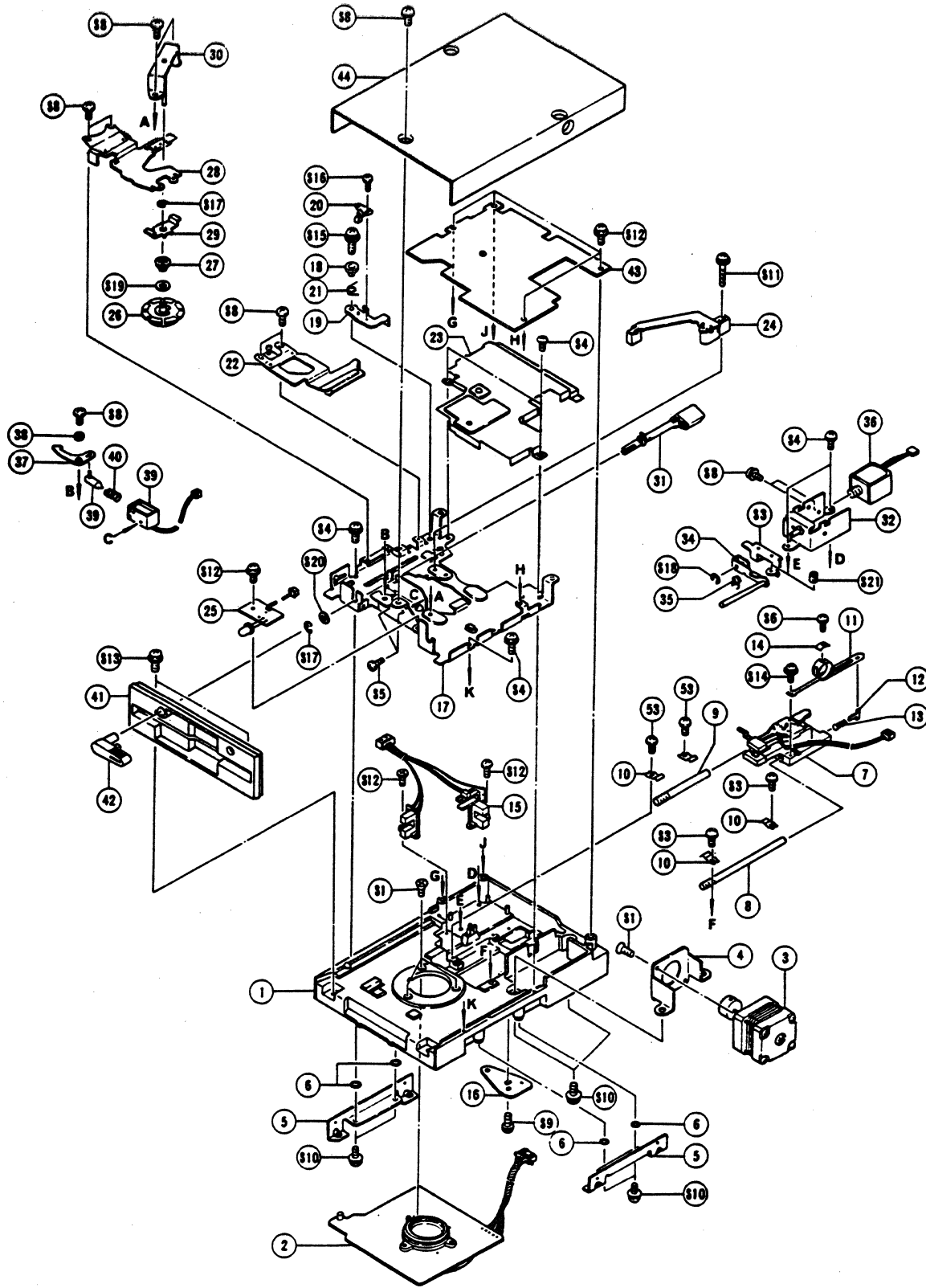

Figure 5-5 Exploded View Drawing

## 5.2 STRUCTURAL PARTS LISTING

Refer to Table 5-2. Item Numbers are shown in Figure 5-5.

**Table 5-2 Listing of Structural Parts**

Item Number	Drawing Number	Name of Part	Quantity
1	J2-5196	Chassis	1
2	J2-5294	Spindle Motor (Type 790PX)	1
3	J3-5295	Stepping Motor (Type 395H)	1
	J3-5296	Stepping Motor (Type MSJC)	1
4	J4-5661	STM Bracket	1
5	J4-5662	Mounting Leg	2
6	J4-5663	Rubber Washer	4
7	JA3-5321A	Head Carriage Assembly	1
8	J4-5671	Guide Shaft (I)	1
9	J4-5672	Guide Shaft (II)	1
10	J4-5673	Guide Shaft Retainer	1
11	JA4-5674	Steel Band Assembly	1
12	J4-5030	Band Fixing Plate B	1
13	J4-5031	Band Spring	1
14	J4-5032	Band Washer	1
15	JA4-5717	Sensor Block Assembly	1
16	J4-5678	Track 00 Sensor Assembly	1
17	JA4-5679	Upper Chassis Assembly	1
18	J4-5718	Eject Lever Collar	1
19	J4-5681	Eject Lever	1
20	J4-5682	Stop Spring	1
21	J4-5684	Eject Spring	1
22	JA4-5685	Bail Assembly	1

## 5.2 STRUCTURAL PARTS LISTING (Continued)

**Table 5-2 Listing of Structural Parts (Continued)**

Item Number	Drawing Number	Name of Part	Quantity
23	J3-5286	Circuit Card Shield Plate	1
24	JA4-5715	Write Protect Sensor	1
25	JA4-5716	LED Card Assembly	1
26	JA3-5265	Collet Assembly	1
27	J4-5253	Pressure Spring	1
28	JA4-5691	Set Arm Assembly	1
29	J3-5288	Collet Actuating Plate	1
30	JA4-5695	Collet Shaft Plate Assembly	1
31	JA4-5698	Clamp Shaft Assembly	1
32	J4-5627	Solenoid Bracket Assembly	1
33	J4-5626	Operating Plate	1
34	J4-5628	Top and Bottom Plate Assembly	1
35	J4-5630	Top and Bottom Plate Spring	1
36	J4-5571	Solenoid	1
37	J3-5291	Door Lock Lever	1
38	J4-5699	Lever Collar	1
39	J4-5701	Solenoid	1
40	J4-5578	Return Spring	1
41	J2-5207	Front Bezel (Note 1)	1
42	JA4-5708	Front Lever Assembly	1
43	J2-5207	Main Circuit Card (Note 2)	1
44	JA4-5709	Shield Cover Assembly	1

Note 1 - Bezel and Front Lever assemblies may be specified within the sales contract.

Note 2 - The Main Circuit Card is available at different revision levels, obtain the correct Drawing Number from the replaced circuit card.

### 5.3 SCREWS AND WASHERS

Refer to Table 5-3. Item Numbers are indicated in Figure 5-5.

**Table 5-3 Listing of Screws and Washers**

Item Number	Drawing Number	Part	Diameter X Length in MM
S1	9030-3006	Screw	M3 X 6
S2	9000-3003	Screw	M3 X 3
S3	9000-3004	Screw	M3 X 4
S4	9000-3006	Screw	M3 X 6
S5	9020-2003	Screw	M2 X 3
S6	9020-2504	Screw	M2.5 X 4
S7	9020-2605	Screw	M2.6 X 5
S8	9020-3004	Screw	M3 X 4
S9	9020-3006	Screw	M3 X 6
S10	9068-3006	Screw	M3 X 6
S11	9068-3015	Screw	M3 X 1.5
S12	9066-3006	Screw	M3 X 6
S13	9066-3008	Screw	M3 X 8
S14	9060-2604	Screw	M2.6 X 4
S15	9010-3005	Screw	M3 X 5
S16	9565-2002	Screw	M2 X 2
S17	9820-0300	E-ring	3mm Diameter
S18	9820-0150	E-ring	1.5mm Diameter
S19	JZ4-0018	Washer	5.1mm Diameter x 0.3mm Thick
S20A	JZ4-0019	Washer	4.1mm Diameter x 0.2mm Thick
S20B	JZ4-0019	Washer	4.1mm Diameter x 0.35mm Thick
S21	JZ4-0028	Screw	M3 X 3

## 5.4 MAIN CIRCUIT CARD COMPONENTS

Refer to Table 5-4

**Table 5-4 Listing of Main Circuit Card Components**

Drawing Number	Name of Part	Quantity	Designation
JA2-5259	M2552K Circuit Card Assembly	1	Note
JA2-5242	M2553/54K Circuit Card Assembly	1	Note
JA3-5373	M2553K Rev 3 Circuit Card Assembly	1	Note
J4-5534I	M2552A Circuit Card Label	1	N/A
J2-5260	M2552K Main Circuit Board	1	Note
J2-5208	M2553/54K Main Circuit Board	1	Note
	M2553K Rev 3 Main Circuit Board	1	Note
JY4-0005	IC, M54578P	1	IC1
JY4-0542	IC, TD62503P	1	IC2
JY4-0554	IC, MB433M	1	IC3
JY4-0537	IC, HD7438	1	IC3
JY4-0595	IC, M53238P	1	IC3
JY4-0555	IC, MB74LS32	2	IC4, IC5
JY4-0551	IC, M74LS32P	2	IC4, IC5
JY4-0138	IC, MB74LS08	1	IC6
JY4-0529	IC, M74LS08P	1	IC6
JY4-0140	IC, MB74LS74A	1	IC7
JY4-0533	IC, M74LS74	1	IC7
JY4-0577	LSI, T5616	1	IC8
JY4-0136	LSI, CX20185	1	IC9
JY4-0152	C-MOS, 74HC08	1	IC10
JY4-0149	Filter, ZBF253D-01	2	L1, L2
JY4-0115	Axial Lead Inductor 560 microhenry, LALO 3KH561K	2	L3, L4
JY4-0116	Axial Lead Inductor 100 microhenry, LALO 3KH101K	2	L5, L6
JY4-0146	Ceramic Oscillator, 4 MHz	1	X1

**Note** The Main Circuit Card is available at different revision levels, obtain the correct Drawing Number from the replaced circuit card.



Table 5-4 Listing of Main Circuit Card Components (Continued)

Drawing Number	Name of Part	Quantity	Designation
SAXR08812Q	Transistor, 2SA881	3	Q1, Q2, Q3
JY4-0141	R-Type Transistor, DTC114EF	5	DT1, DT2, DT3 DT5, DT6
JY4-0142	R-Type Transistor, DTA114EF	1	DT4
JY4-0067A	Diode, 1SS138	10	D1, D2, D3, D4, D5, D6, D7, D8, D9, D10
JY4-0036	Diode Pair, MA154WK	1	DA1
JY4-0143	Diode Pair, MA156	1	DA2
JY4-0035	Diode Pair, MA154WA	4	DA3, DA4, DA5, DA6
CAMT1C103B	Ceramic Cap, 103M 16V	15	C1, C4, C5, C6, C7, C8, C9, C10, C11, C12, C13, C19, C35, C36, C37
CANT1W333A	Ceramic Cap, 333N 12V	2	C25, C26
CAJTIH330B	Ceramic Cap, 33PM 50V	2	C15, C16
CDZU1H104A	Ceramic Cap, 104Z 50V	5	C23, C29, C30, C32, C33
CAKT1H271B	Ceramic Cap, 270PF 50V	2	C24, C27
CAKT1H101B	Ceramic Cap, 100PF 50V	1	C28
CAKT1H102B	Ceramic Cap, 1000PF 50V	1	C31
CEME1C106E	Electrolytic Cap, 10 uf 16V	1	C2
CEME1C226E	Electrolytic Cap, 22 uf 16V	1	C3
CEME1H334E	Electrolytic Cap, 0.33 uf 50V	2	C14, C18
CEME1H105E	Electrolytic Cap, 1 uf 50V	3	C17, C22, C38
CEME1C336E	Electrolytic Cap, 33 uf 16V	1	C21
CEME1C476E	Electrolytic Cap, 47 uf 16V	1	C34

Table 5-4 Listing of Main Circuit Card Components (Continued)

Drawing Number	Name of Part	Quantity	Designation
RDJR23100A	Carbon Resistor 10 Ohm 1/5 W $\pm 5\%$	1	R55, R56
RDJR23151A	Carbon Resistor 150 Ohm 1/5 W $\pm 5\%$	9	R1 Thru R8, R10
RDJR23221A	Carbon Resistor 220 Ohm 1/5 W $\pm 5\%$	2	R24, R37
RDJR23431A	Carbon Resistor 430 Ohm 1/5 W $\pm 5\%$	1	R40
RDJR23561A	Carbon Resistor 560 Ohm 1/5 W $\pm 5\%$	1	R33
RDJR23102A	Carbon Resistor 1.0K Ohm 1/5 W $\pm 5\%$	3	R25, R34, R66
RDJR23222A	Carbon Resistor 2.2K Ohm 1/5 W $\pm 5\%$	6	R14, R15, R21, R22, R45, R62
RDJR23242A	Carbon Resistor 2.4K Ohm 1/5 W $\pm 5\%$	2	R47, R50
RDJR23272A	Carbon Resistor 2.4K Ohm 1/5 W $\pm 5\%$	1	R54
RDJR23302A	Carbon Resistor 3.0K Ohm 1/5 W $\pm 5\%$	1	R46
RDJR23362A	Carbon Resistor 3.6K Ohm 1/5 W $\pm 5\%$	1	R51
RDJR23472A	Carbon Resistor 4.7K Ohm 1/5 W $\pm 5\%$	14	R11, R13, R20, R27, R28, R29, R30, R31, R32, R36, R39, R59, R63, R64
RDJR23103A	Carbon Resistor 10K Ohm 1/5 W $\pm 5\%$	3	R23, R53, R38
RDJR23123A	Carbon Resistor 12K Ohm 1/5 W $\pm 5\%$	1	R44
RDJR23223A	Carbon Resistor 22K Ohm 1/5 W $\pm 5\%$	1	R68

Table 5-4 Listing of Main Circuit Card Components (Continued)

Drawing Number	Name of Part	Quantity	Designation
RDJR23473A	Carbon Resistor 47K Ohm 1/5 W $\pm$ 5%	2	R18, R26
RDJR23513A	Carbon Resistor 51K Ohm 1/5 W $\pm$ 5%	7	R12, R17, R19, R48, R49, R60, R61
RDJR23104A	Carbon Resistor 100K Ohm 1/5 W $\pm$ 5%	2	R1, R16
RNFRF3001A	Metal Film Resistor 3K Ohm 1/5 W $\pm$ 5 %	1	R53
RNFRF4121A	Metal Film Resistor 4.12K Ohm 1/5 W $\pm$ 5 %	1	R52
RNFRF2432A	Metal Film Resistor 24.3K Ohm 1/5 W $\pm$ 5 %	1	R43
RNFRF2742A	Metal Film Resistor 27.4K Ohm 1/5 W $\pm$ 5 %	1	R41
RNFRF2942A	Metal Film Resistor 29.4K Ohm 1/5 W $\pm$ 5 %	1	R42
RSJF30301C	Metal Oxide Film Resistor 300 Ohm 1 W $\pm$ 5 %	1	R57
RSJF30471C	Metal Oxide Film Resistor 470 Ohm 1 W $\pm$ 5 %	1	R58
JY4-0128	Block Header, 12 Pin	1	J8
JY4-0544	Post with Base, 2 Pin	2	J6, J10
JY4-0579	Base Post, 2 Pin	1	J5
JY4-0580	Base Post, 4 Pin	1	J7
JY4-0581	Base Post, 5 Pin	1	J3
JY4-0582	Base Post, 6 Pin	2	J4, J9
JY4-0151E	Shorting Connector 1 Row, 5 Pin	1	SM1, SM2, 300
JY4-0583	Shorting Connector 2 Row, 14 Pin	1	DS0/3, HD, HM, TM
JY4-0547	Shorting Connector 2 Row, 8 Pin	2	INUSE, HL, TD, MR LD, LC, LB, LA

**Table 5-4 Listing of Main Circuit Card Components (Continued)**

Drawing Number	Name of Part	Quantity	Designation
JY4-0548	Shorting Connector 2 Row, 6 Pin	3	DC, RY, DO / DM2, DM1, MOD / 1SP, HD, 2SP, LSP
JY4-0151B	Shorting Connector 1 Row, 2 Pin	1	DL
JY4-0151C	Shorting Connector 1 Row, 3 Pin 3 Row, 3 Pin	5	DL1, DL2 / RI, DI MS, MM / DSR, STR DK2, DK2
JY4-0596	Shorting Connector 1 Row, 7 Pin	1	TP1 - TP7
JY4-0077	Shorting Bar	A/R	A/R
JY4-0078	J2 Connector and Band	1	J2
JY4-0021	J2 Connector without Band	1	J2
JY4-0022	Band for J2 Connector	1	J2
JY4-0514	J2 Connector without Ban	1	J2
JY4-0515	Band for J2 Connector	1	J2

## 5.5 CIRCUIT CARD LAYOUT AND SCHEMATIC DIAGRAMS

In the following schematic drawing, unless otherwise indicated:

Resistance (R) is given in Ohms, with a power rating of 1/6 Watt and a tolerance rating of  $\pm 5\%$ .

Resistor Arrays (RA) are given in Ohms, with a power rating of 1/5W and a tolerance rating of  $\pm 5\%$ .

Capacitors (C) are rated in picofarads with a voltage rating of 50 volts.

Tolerance (for Resistors, Resistor Arrays and Capacitors) are coded as follows:

G =  $\pm 2\%$ , K =  $\pm 10\%$ , M =  $\pm 20\%$ , Z = + 80% and - 20%.

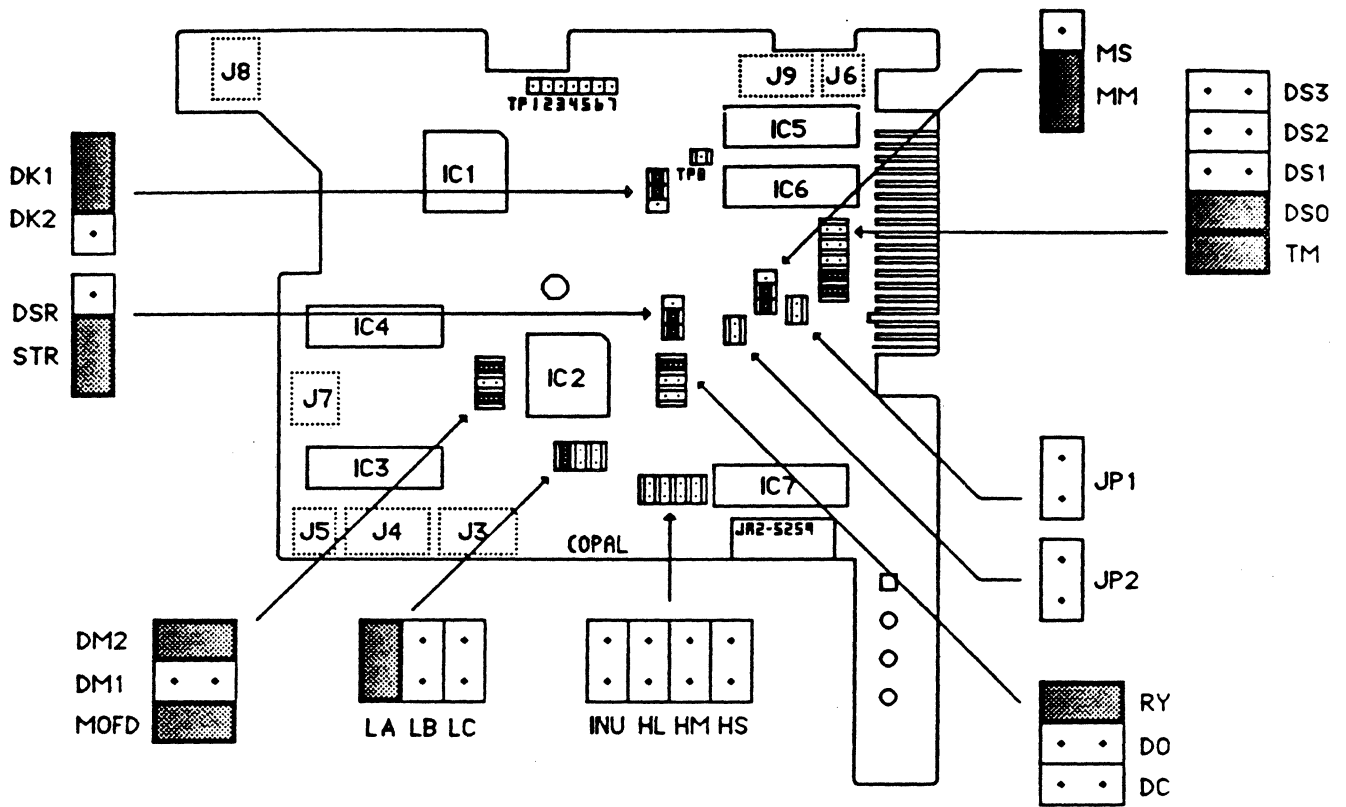

Figure 5-6 M2552K Revision 1 Circuit Card Layout

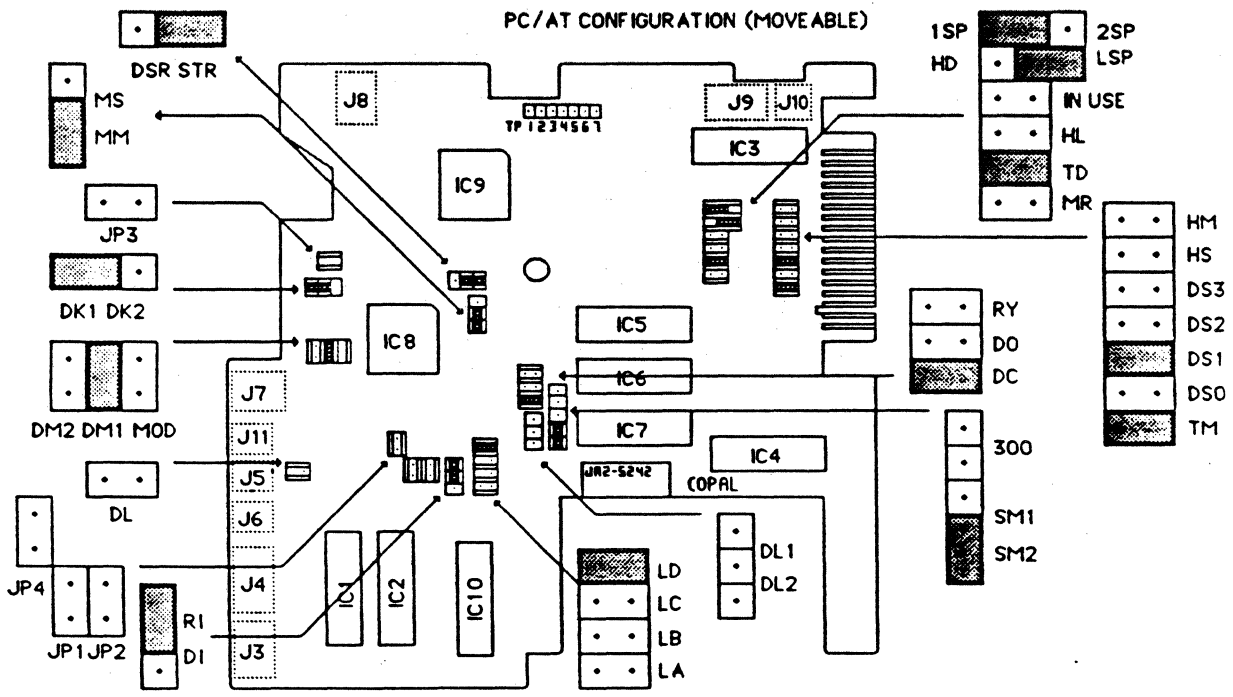

Figure 5-7 M2553/54K Revision 2 Circuit Card Layout



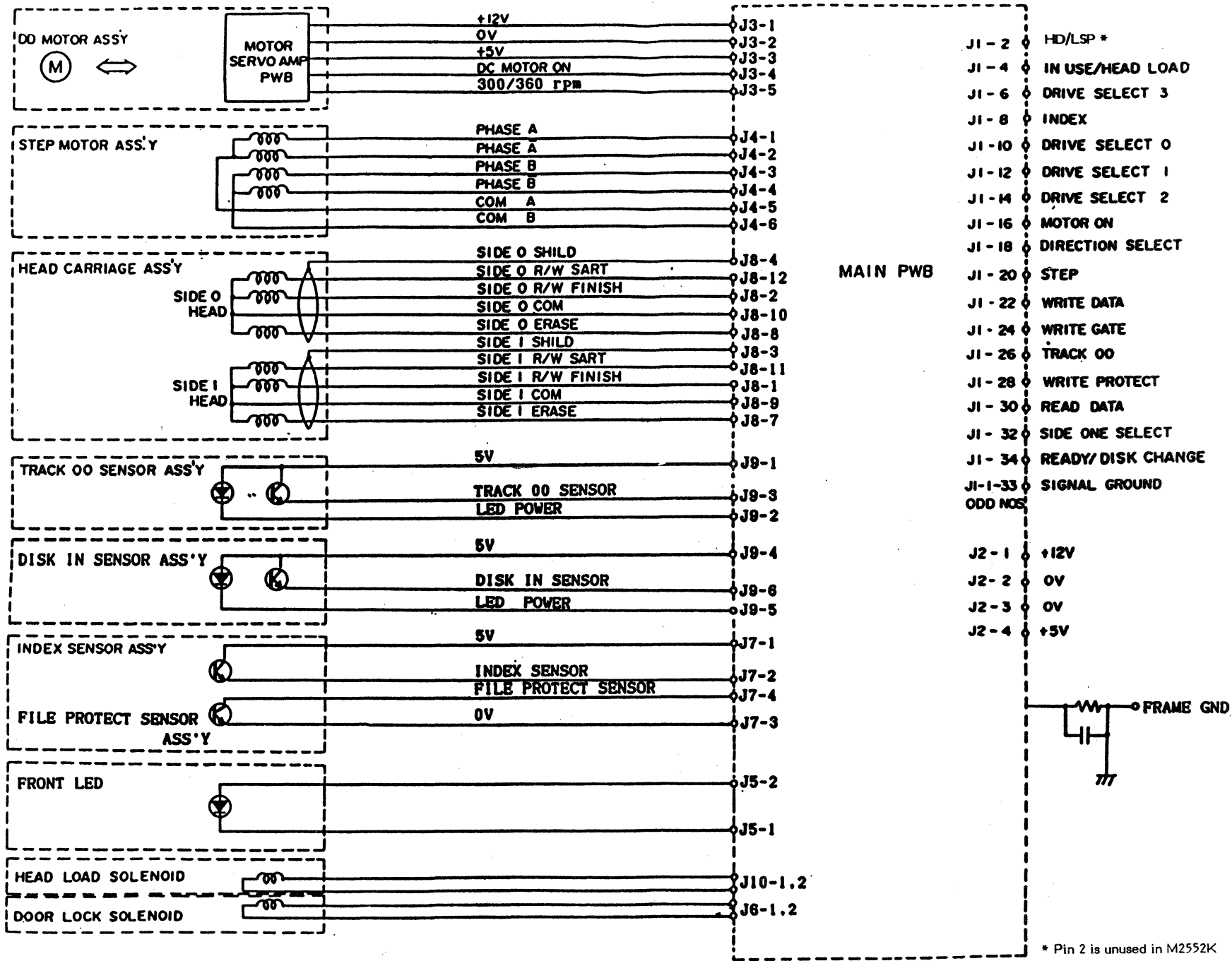
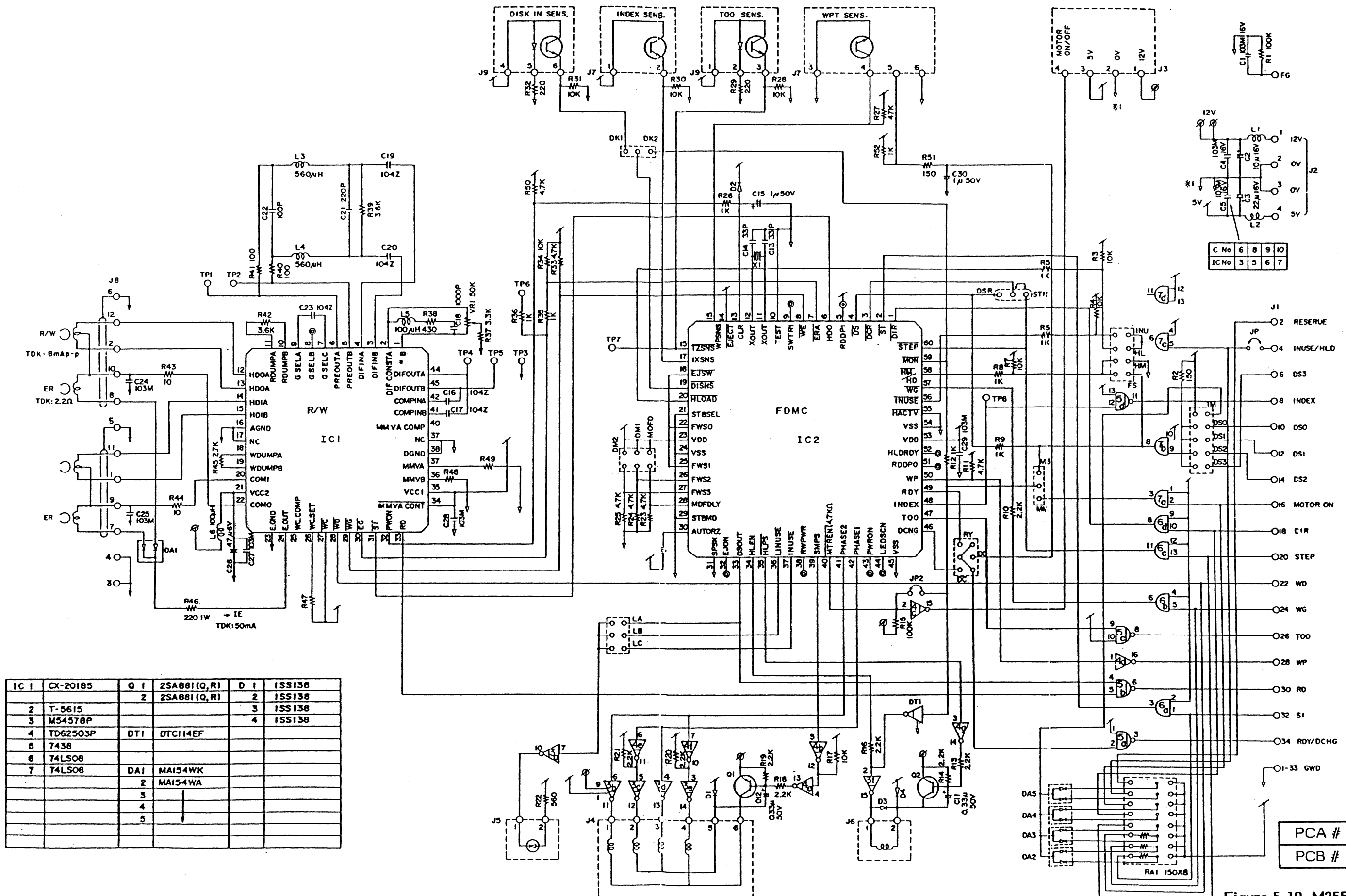

Figure 5-9 Interconnect Diagram





IC	Part No.	QTY	Part No.	D	Part No.
1	CX-20185	1	2SA881 (Q,R)	1	ISS138
2	T-5615	2	2SA881 (Q,R)	2	ISS138
3	M54578P			3	ISS138
4	TD62503P	DT1	DTCI14EF	4	ISS138
5	7438				
6	74LS08				
7	74LS08	DA1	MA154WK		
		2	MA154WA		
		3			
		4			
		5			

C No	6	8	9	10
IC No	3	5	6	7

PCA #	JA2-5259
PCB #	J2-5290

Figure 5-10 M2552K Revision:1 Schematic Diagram



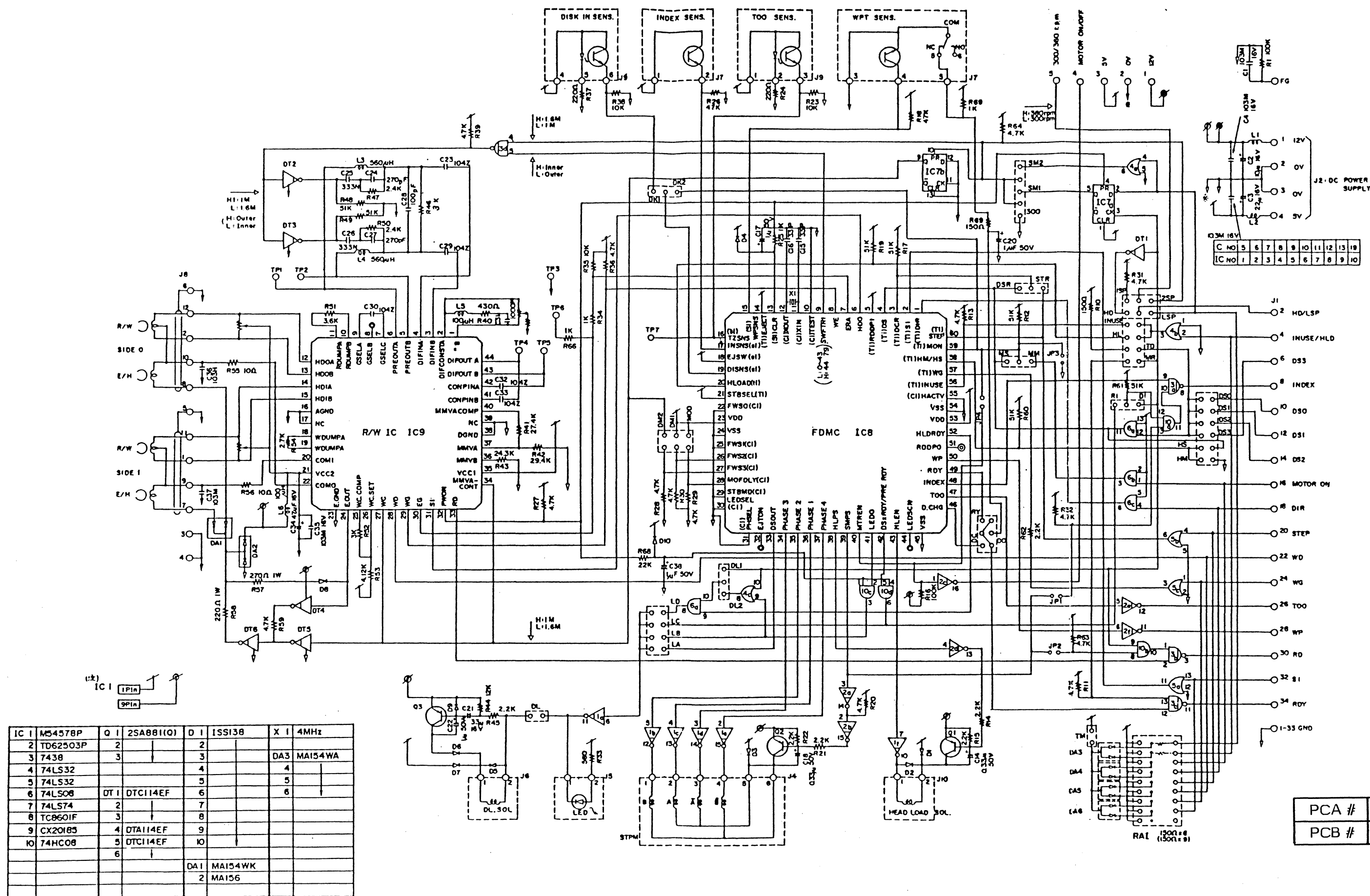

IC 1	M54578P	Q 1	2SA881(Q)	D 1	ISSI38	X 1	4MHz
2	TD62503P	2		2		DA3	MAI54WA
3	7438	3		3			
4	74LS32			4			
5	74LS32			5			
6	74LS08	DT 1	DTC114EF	6			
7	74LS74	2		7			
8	TC8601F	3		8			
9	CX20185	4	DTA114EF	9			
10	74HC08	5	DTC114EF	10			
		6					
				DA1	MAI54WK		
				2	MAI56		

PCA #	JA2-5208B
PCB #	J2-5242B

Figure 5-11 M2553K and M2554K Revision 2 Schematic Diagram



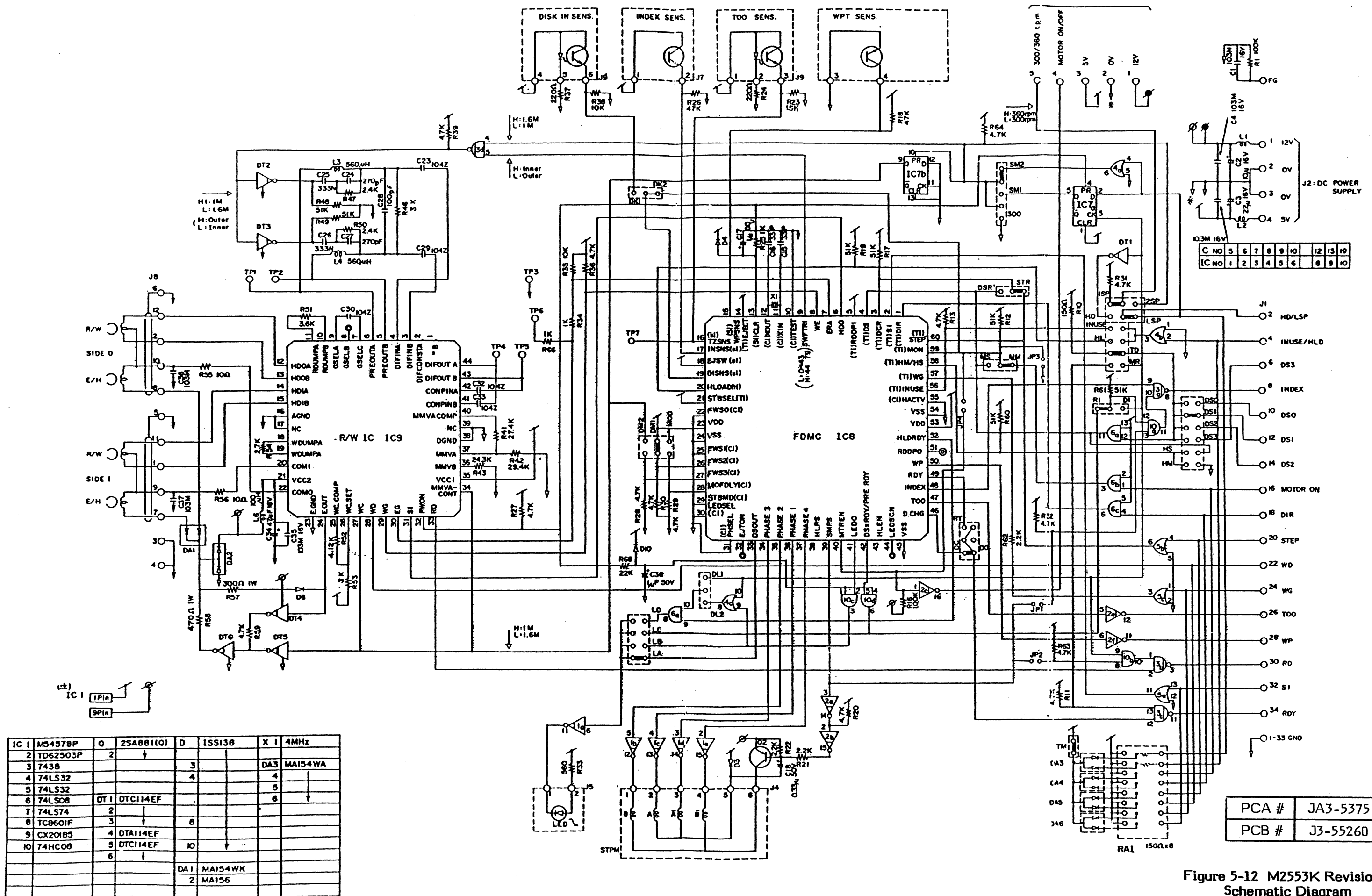

Figure 5-12 M2553K Revision 3 Schematic Diagram

