



KTM HINDLE ULTRA-SEAL BALL VALVES

SERIES 300

A range of two piece full bore, flanged, free floating (seat supported) ball valves, incorporating mounting dimensions to BS EN 15081, featuring soft, metal and carbon seated designs



FEATURES

- Two piece full bore design, flanged construction in carbon steel, stainless steel and special alloys.
- Designed in accordance with ASME B16.34, BS EN ISO 17292 and ISO 14313/API 6D.
- Floating ball design for bi-directional shut-off.
- Flexing soft seat design for superior shut-off across a range of pressures with minimum operating torque.
- Low temperature and cryogenic designs for service down to -196°C available on request.
- Spring energized metal and carbon seat designs permitting tight shut-off and positive cavity pressure relief.
- Fused hard nickel alloy, chromium carbide or tungsten carbide coated seat and ball designs for abrasive and high temperature service.
- Hard carbon seat design for medium temperature applications.
- High integrity shaft seal minimizing the potential for atmospheric leakage.
- Fugitive emission performance to BS EN ISO 15848-2 class A.
- Corrosion resistant trim. Standard valves incorporate balls and shafts of stainless steel for long service life.
- Fire test certified. All sizes and pressure ratings are covered by approved certification.
- Anti-static and blow-out proof shaft design.
- Most designs offer cavity pressure relief to upstream in event of thermal expansion.
- Could be integrated into a SIL 3 environment safety instrumented system.

SEAT DESIGN

There are three seat designs within the two piece Ultra-Seal Series 300 range.

- PTFE soft seat design for non abrasive service.
- Hard carbon seat design for clean applications.
- Metal seat design for abrasive service.

A range of one piece Series 110/200 Ultra-Seal reduced bore valves are also available.

DESIGN RANGE

Full bore: NPS ½ - 8 (DN 15 - 200)
 Pressure class: 150 and 300 depending on seat design.

Option

Full bore one piece soft seated design ball valve range is also available on request.



KTM HINDLE ULTRA-SEAL BALL VALVES

SERIES 300

VALVE APPLICATIONS

Ultra-Seal ball valves are ideally suited for use in a wide variety of industries including petrochemical, chemical, oil and gas, LNG and marine with a choice of seat designs.

| | |
|--------------------------|---|
| PTFE seat applications | Cryogenic temperatures down to -196°C and non abrasive services up to 230°C depending on the grade of material. Vacuum service down to 0.1 mbar.A. |
| Carbon seat applications | Clean service from -20°C up to 300°C, suitable for use with organic solvents. Ideally suited for Purified Terephthalic Acid (PTA). |
| Metal seat applications | Clean or Abrasive services from -50°C up to 450°C and/or applications where positive cavity relief is required together with bi-directional flow. |

Soft seated valve sizes NPS ½ - 16 (DN 15 - 400) reduced bore available in 1-piece Series 110/200.

Metal/carbon seated valve sizes NPS 1 - 6 (DN 25 - 150) reduced bore. Also available in 1-piece Series 110/200.

VALVE SEAT DESIGN RANGE

| Class | Seat type | NPS ½ - 2 | NPS 3 - 6 | NPS 8 |
|-------|--------------|------------|-------------|--------|
| | | DN 15 - 50 | DN 80 - 150 | DN 200 |
| 150 | Soft | ✓ | ✓ | ✓ |
| | Metal/Carbon | ✓ | ✓ | |
| 300 | Soft | ✓ | ✓ | ✓ |
| | Metal/Carbon | ✓ | ✓ | |

TECHNICAL SPECIFICATIONS

| | | |
|-----------------------------|---------------------------|--|
| Design | BS EN ISO 17292 (BS 5351) | ISO 14313/API 6D ^[2] |
| | BS EN 1983 | ASME B16.34 |
| Face to face ^[1] | BS EN 558 | ASME B16.10 |
| Fire testing | BS EN ISO 10497 | |
| Pressure testing | BS ISO 5208 | API 598 |
| | BS EN 12266-1 | ISO 14313/API 6D ^[2] |
| Material certification | BS EN 10204 | NACE MR 0175-2002 |
| | | MR0103 and ISO 15156-2:2003 on request |
| Quality assurance | EN 29001 | |
| | BS EN ISO 9001-2008 | |
| ISO top mounting details | BS EN 15081 | |

NOTES

1. Long and short patterns available.
2. Conformity to ISO 14313/API 6D is limited to all class 150 valves and class 300 up to NPS 6 (DN 150).

STANDARD OPERATOR FOR SOFT SEATS

| Class | Lever NPS (DN) | T-Bar NPS (DN) | Gearbox NPS (DN) |
|-------|-----------------|------------------|------------------|
| 150 | ½ - 2 (15 - 50) | 3 - 6 (80 - 150) | 8 (200) |
| 300 | ½ - 2 (15 - 50) | 3, 4 (80, 100) | 6, 8 (150, 200) |

STANDARD OPERATOR FOR METAL/CARBON SEATS

| Class | Lever NPS (DN) | T-Bar NPS (DN) | Gearbox NPS (DN) |
|-------|-----------------|------------------|-------------------|
| 150 | ½ - 2 (15 - 50) | 3 - 6 (80 - 150) | 4 - 6 (100 - 150) |
| 300 | ½ - 2 (15 - 50) | | 3 - 6 (80 - 150) |

STANDARD OPERATOR FOR SOFT SEATS

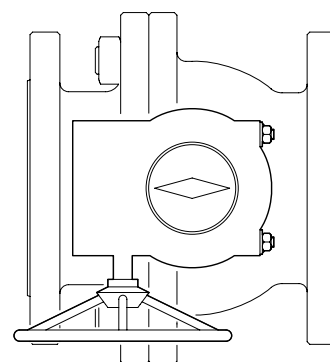

KTM HINDLE ULTRA-SEAL BALL VALVES

SERIES 300

FACE TO FACE STANDARD ASME B16.10/BS EN 558 - CLASS 150

| NPS | DN | Short | Long |
|-------------|---------|-------|------|
| 1/2 - 1 1/2 | 15 - 40 | ✓ | ✓ |
| 2 | 50 | ✓ | ✓ |
| 3 | 80 | ✓ | ✓ |
| 4 | 100 | ✓ | ✓ |
| 6 | 150 | ✓ | |
| 8 | 200 | ✓ | |

FACE TO FACE STANDARD ASME B16.10/BS EN 558 - CLASS 300

| NPS | DN | Short | Long |
|-------------|---------|-------|------|
| 1/2 - 1 1/2 | 15 - 40 | ✓ | ✓ |
| 2 | 50 | ✓ | ✓ |
| 3 | 80 | ✓ | ✓ |
| 4 | 100 | ✓ | ✓ |
| 6 | 150 | ✓ | |
| 8 | 200 | | ✓ |

NOTE

These tables identify the standard face to face length of Ultra-Seal ball valves. Alternative pattern lengths are available on request.

SOFT SEATED DESIGN FEATURES

Ultra-Seal soft seated ball valves utilize PTFE seats for maximum chemical compatibility combined with minimum coefficient of friction.

Temperature range

Suitable for a range of non abrasive service temperatures between -196°C and 230°C, depending on the seat material.

Seat design

The seat rings incorporate a flexing design which ensures positive sealing across the pressure range, even at low differential pressures. Slots on the external diameter ensure pressure equalisation between the upstream and the valve cavity, reducing the load on the downstream seat and minimizing operating torques.

Seat leakage

Floating ball design provides tight shut-off in both directions to BS ISO 5208 rate A.

Fugitive emissions

High integrity shaft seals give low emission performance, even under thermal cycling. Tested and approved to Shell MESC SPE 77/312 class A up to DN 40, NPS 1 1/2 and class B for sizes DN 50, NPS 2 and above. Meets the leakage performance of BS EN ISO 15848-2 class A.

METAL SEATED DESIGN FEATURES

Ultra-Seal metal seated ball valves incorporate proven metal seated technology together with advanced ball/seat coatings, spring materials and low emission seals.

Temperature range

Suitable for a range of service temperatures between -50°C and 450°C for fluids carrying abrasive particles and where positive cavity relief is required.

For temperatures above 300°C, heat dissipation bonnets are available for gland isolation outside lagging area. Refer to page 4 for minimum bonnet lengths.

Coatings

A range of ball and seat coating materials are available providing hardness values from 60 HRC up to 75 HRC and coating thicknesses between 500 µm and 200 µm.

Seat design

Body and seat design ensures controlled spring compression, giving optimum seat and seal performance, together with constant running torque.

Spring and seat seals are protected from the main flowstream to prevent jamming and premature seat failure.

Seat leakage

The live loaded seat design gives reliable bi-directional sealing to BS ISO 5208 rate A in sizes up to DN 50, NPS 2 and rate B for DN 80, NPS 3 and above. Leak rates to ANSI/FCI 70-2 are also applicable to class VI up to DN 50, NPS 2 and class V for DN 80 and above.

Fugitive emissions

High integrity shaft seals give low emission performance, even under thermal cycling.

Tested and approved to Shell MESC SPE 77/312 class A and meets the leakage performance of BS EN ISO 15848-2 class A.

KTM HINDLE ULTRA-SEAL BALL VALVES

SERIES 300

CARBON SEATED DESIGN FEATURES

Incorporating similar design technology to the metal seated range of ball valves, including spring materials and low emission seals.

Temperature range

Suitable for a range of service temperatures between -20°C and 300°C for use with clean organic solvents including PTA. Not recommended for fluids carrying abrasive particles. Heat dissipation bonnets are available for gland isolation outside lagging area.

Seat design

Carbon graphite seats are assembled into seat holders by thermal control fitting. This ensures correct support for the seat material throughout the service conditions.

Seat leakage

The live loaded seat design gives reliable tight shut off in both directions to BS ISO 5208 rate A.

Fugitive emissions

High integrity shaft seals give low emission performance, even under thermal cycling. Tested to Shell MESC SPE 77/312 class A and meets the leakage performance of BS EN ISO 15848-2 class A.

CRYOGENIC SERVICE DESIGN FEATURES

KTM Hindle ball valves are recognized leaders in the field of low temperature and cryogenic applications, with more than twenty years experience in this specialized market sector. KTM Hindle experience includes many substantial international contracts for low temperature and cryogenic valves, including several large projects on liquefied natural gas (LNG) plants, for major users and engineering contractors world-wide.

Ultra-Seal cryogenic ball valves are type approval tested by Shell GSI and listed on Shell TAMAP database.

Extensions

A one-piece extension bonnet is fitted so as to relocate the shaft seal away from the cold area and to provide a pressurized column within which the cold liquid phase is changed, by heat transfer with the environment, to the gaseous phase. The extension also allows for the insulation of the valve body. KTM Hindle offer two extension lengths for each size of valve, in accordance with Shell specifications.

Cavity relief

For temperatures below -50°C a pressure equalizing hole is provided in the ball at the upstream (sleeve end) of the valve, to provide positive cavity relief. This renders the valve uni-directional and the body is marked accordingly.

Operating torque

Low temperature service requires higher operating torque and gearboxes may be required to replace lever operators. Since temperature is only one of the factors affecting operating torque, customers are advised to provide full application details with enquiries.

Drip collars

Customers may specify the fitting of drip collars/trays, which minimize ice accumulation on the extension and prevent possible damage to lagging.

Acceptance testing

Dedicated in-house test facilities enable valves to be performance tested, at cryogenic temperatures, in accordance with major international standards or customer's individual requirements.

EXTENSION BONNET LENGTHS

| Valve size | | | Extension length | | | |
|------------|-------|-------|------------------|-----|------------------|-----|
| | | | -30°C to -109°C | | -110°C to -196°C | |
| DN | NPS | Class | inch | mm | inch | mm |
| 15 - 20 | ½ - ¾ | 150 | 4 | 100 | 8 | 200 |
| | | 300 | 4 | 100 | 8 | 200 |
| 25 - 50 | 1 - 2 | 150 | 5 | 125 | 10 | 250 |
| | | 300 | 5 | 125 | 10 | 250 |
| 80 - 100 | 3 - 4 | 150 | 6 | 150 | 12 | 300 |
| | | 300 | 6 | 150 | 12 | 300 |
| 150 - 200 | 6 - 8 | 150 | 7 | 175 | 14 | 350 |
| 100 - 200 | 4 - 8 | 300 | 7 | 175 | 14 | 350 |

KTM HINDLE ULTRA-SEAL BALL VALVES

SERIES 300

PARTS IDENTIFICATION SERIES 300 – FULL BORE SOFT SEATED

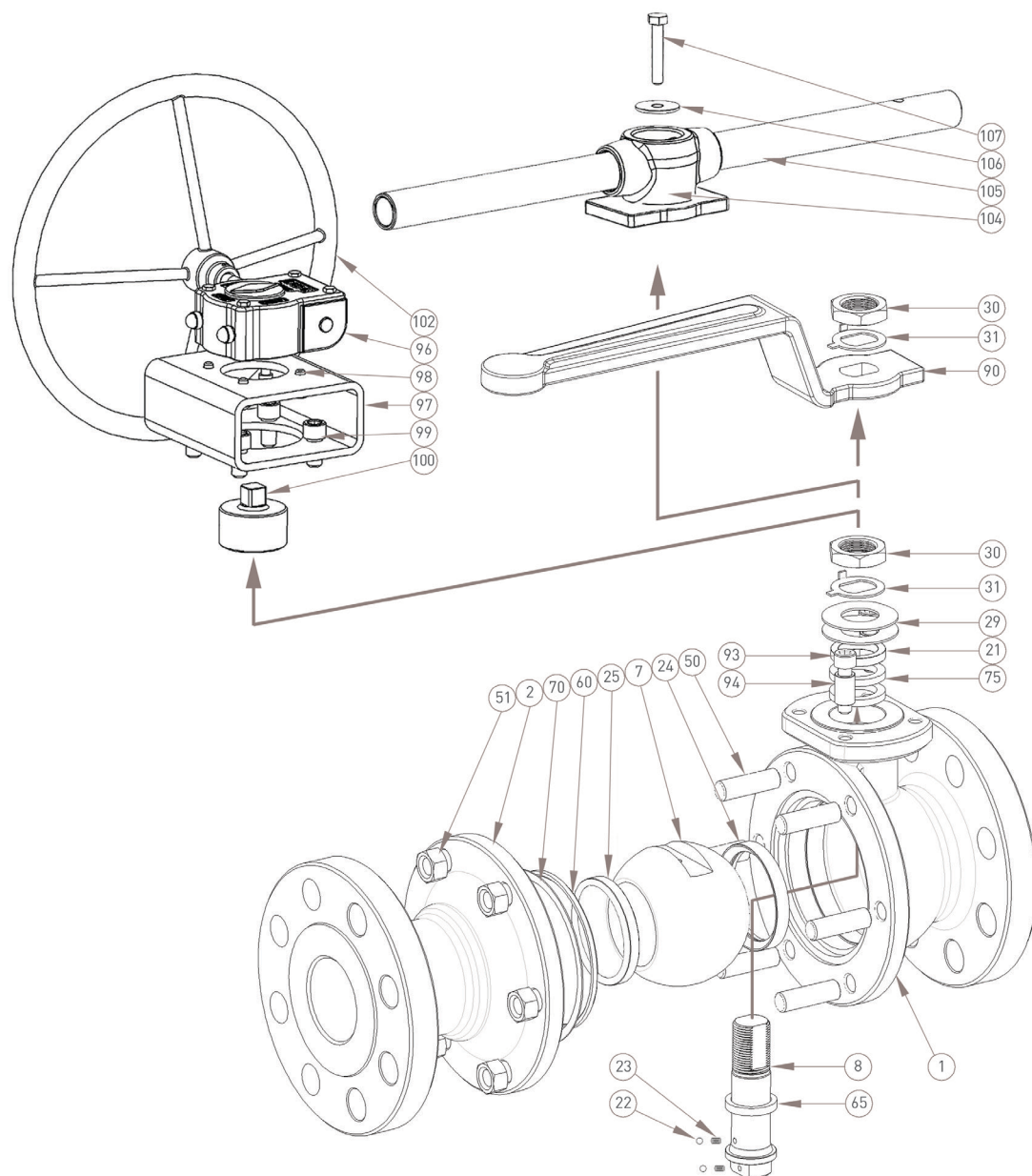

PARTS LIST

| Item | Component | Item | Component | Item | Component |
|------|--------------------------|------|--------------------|------|------------------|
| 1 | Body | 31 | Tab washer | 97 | Mounting bracket |
| 2 | Connector | 50 | Body studbolt | 98 | Gearbox screw |
| 7 | Ball | 51 | Body nut | 99 | Bracket screw |
| 8 | Shaft | 60 | Body primary seal | 100 | Coupling |
| 21 | Gland collar | 65 | Shaft primary seal | 102 | Handwheel |
| 22 | Shaft anti-static ball | 70 | Body fire seal | 104 | T-Bar adaptor |
| 23 | Shaft anti-static spring | 75 | Shaft fire seal | 105 | T-Bar tube |
| 24 | Body seat | 90 | Handlever | 106 | T-Bar washer |
| 25 | Connector seat | 93 | Stop screw | 107 | T-Bar screw |
| 29 | Gland spring | 94 | Stop collar | | |
| 30 | Shaft nut | 96 | Gearbox | | |

NOTES

1. Standard materials of construction are given on page 10.

KTM HINDLE ULTRA-SEAL BALL VALVES

SERIES 300

PARTS IDENTIFICATION SERIES 300 - FULL BORE METAL / CARBON SEATED

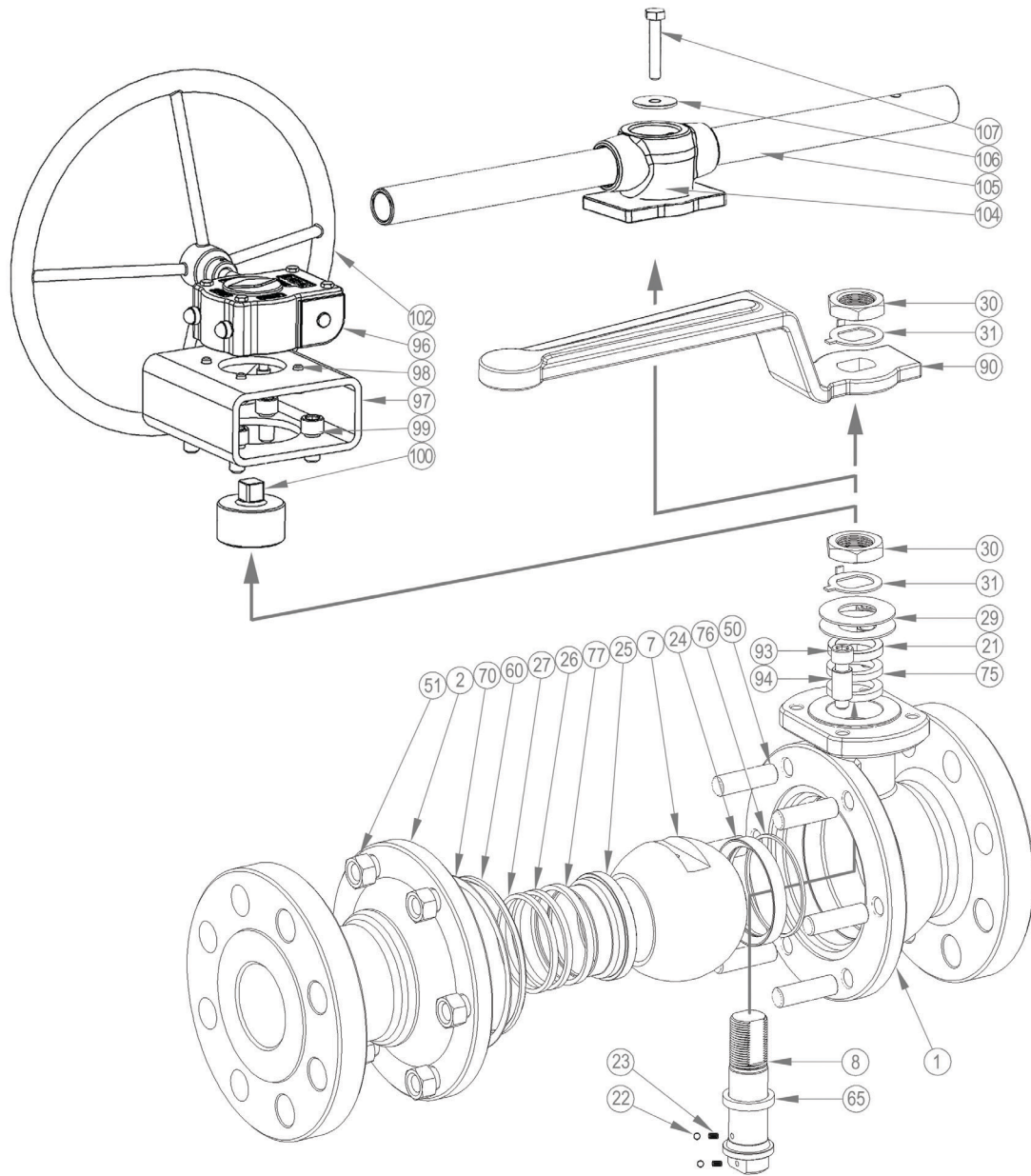

PARTS LIST

| Item | Component | Item | Component | Item | Component |
|------|--------------------------|------|---------------------|------|------------------|
| 1 | Body | 30 | Shaft nut | 93 | Stop screw |
| 2 | Connector | 31 | Tab washer | 94 | Stop collar |
| 7 | Ball | 50 | Body studbolt | 96 | Gearbox |
| 8 | Shaft | 51 | Body nut | 97 | Mounting bracket |
| 21 | Gland collar | 60 | Body primary seal | 98 | Gearbox screw |
| 22 | Shaft anti-static ball | 65 | Shaft primary seal | 99 | Bracket screw |
| 23 | Shaft anti-static spring | 75 | Shaft fire seal | 100 | Coupling |
| 24 | Body seat | 76 | Body seat seal | 102 | Handwheel |
| 25 | Connector seat | 77 | Connector seat seal | 104 | T-Bar adaptor |
| 26 | Seat energizer | 90 | Handlever | 105 | T-Bar tube |
| 27 | Seat spring | 91 | Handlever washer | 106 | T-Bar washer |
| 29 | Gland spring | 92 | Handlever screw | 107 | T-Bar screw |

NOTES

- Standard materials of construction are given on page 10.
- Heat dissipation bonnets available for gland isolation outside lagging areas.

KTM HINDLE ULTRA-SEAL BALL VALVES

SERIES 300

DIMENSIONS SERIES 300 - FULL BORE SOFT SEATED

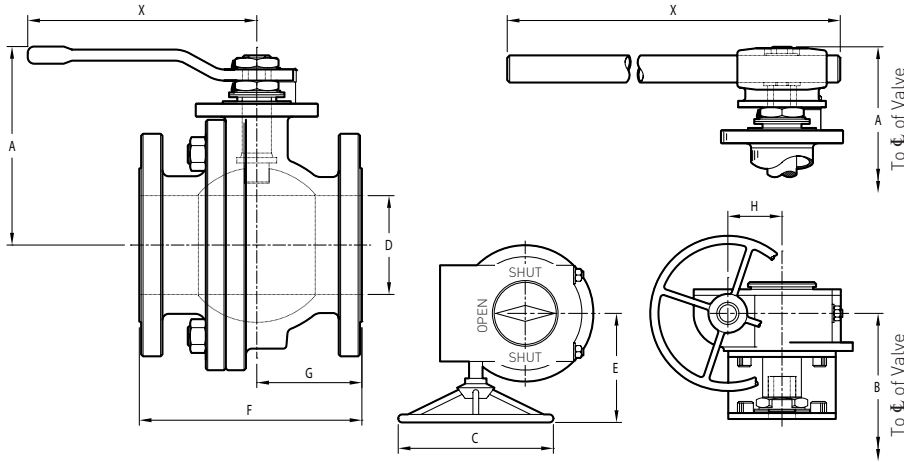

CLASS 150 - MODEL 315F

| Size | | A | | B | | C | | D | | E | | F | | G | | H | | X | | Weight |
|-------|-----|---------------------------------|-------|----------|-------|------|-----|-------|-------|---------|-----|-------------------------------|-------|-------------------------------|-------|-----|----|-------------------------------|-------|--------|
| NPS | DN | in. | mm | in. | mm | in. | mm | in. | mm | in. | mm | in. | mm | in. | mm | in. | mm | in. | mm | kg |
| 1/2 | 15 | 4 ⁷ / ₃₂ | 107.2 | - | - | - | - | 1/2 | 12.7 | - | - | 4 ¹ / ₄ | 108.0 | 1 ³ / ₄ | 44.5 | - | - | 6 ¹ / ₄ | 158.8 | 2.1 |
| 3/4 | 20 | 4 ¹ / ₂ | 114.3 | - | - | - | - | 3/4 | 19.1 | - | - | 4 ⁵ / ₈ | 117.5 | 2 | 50.8 | - | - | 6 ¹ / ₄ | 158.8 | 3.2 |
| 1 | 25 | 4 ¹¹ / ₁₆ | 119.1 | - | - | - | - | 1 | 25.4 | - | - | 5 | 127.0 | 2 | 50.8 | - | - | 6 ¹ / ₄ | 158.8 | 4.0 |
| 1 1/2 | 40 | 5 ⁵ / ₁₆ | 141.3 | - | - | - | - | 1 1/2 | 38.1 | - | - | 6 1/2 | 165.1 | 2 5/8 | 67.5 | - | - | 7 11/16 | 195.3 | 7.4 |
| 2 | 50 | 7 1/16 | 179.4 | - | - | - | - | 2 | 50.8 | - | - | 7 | 177.8 | 3 | 76.2 | - | - | 10 3/8 | 263.5 | 12.9 |
| 3 | 80 | 8 7/8 | 205.9 | - | - | - | - | 3 | 76.2 | - | - | 8 | 203.2 | 3 3/4 | 95.3 | - | - | 20 | 508.0 | 27.3 |
| 4 | 100 | 8 11/16 | 220.1 | - | - | - | - | 4 | 101.6 | - | - | 9 | 228.6 | 4 1/4 | 108.0 | - | - | 20 | 508.0 | 42.5 |
| 6 | 150 | 11 3/16 | 284.5 | - | - | - | - | 6 | 152.4 | - | - | 10 1/2 | 266.7 | 5 1/4 | 133.4 | - | - | 26 1/2 | 673.1 | 80.2 |
| 8 | 200 | - | - | 17 11/16 | 448.5 | 7.87 | 200 | 8 | 203.2 | 11 5/16 | 288 | 18 | 457.2 | 8 | 203.2 | 2.8 | 71 | - | - | 125.0 |

CLASS 300 - MODEL 330F

| Size | | A | | B | | C | | D | | E | | F | | G | | H | | X | | Weight |
|-------|-----|---------------------------------|-------|--------|-------|--------|-----|-------|-------|----------------------------------|-----|--------|-------|-------|-------|-----|----|---------|-------|--------|
| NPS | DN | in. | mm | in. | mm | in. | mm | in. | mm | in. | mm | in. | mm | in. | mm | in. | mm | in. | mm | kg |
| 1/2 | 15 | 4 ⁷ / ₃₂ | 107.2 | - | - | - | - | 1/2 | 12.7 | - | - | 5 1/2 | 139.7 | 1 7/8 | 47.6 | - | - | 6 1/4 | 158.8 | 2.6 |
| 3/4 | 20 | 4 1/2 | 114.3 | - | - | - | - | 3/4 | 19.1 | - | - | 6 | 152.4 | 2 1/4 | 57.2 | - | - | 6 1/4 | 158.8 | 4.3 |
| 1 | 25 | 4 ¹¹ / ₁₆ | 119.1 | - | - | - | - | 1 | 25.4 | - | - | 6 1/2 | 165.1 | 2 5/8 | 66.7 | - | - | 6 1/4 | 158.8 | 5.8 |
| 1 1/2 | 40 | 5 ⁵ / ₁₆ | 141.3 | - | - | - | - | 1 1/2 | 38.1 | - | - | 7 1/2 | 190.5 | 2 5/8 | 66.7 | - | - | 7 11/16 | 195.3 | 10.7 |
| 2 | 50 | 7 1/16 | 179.4 | - | - | - | - | 2 | 50.8 | - | - | 8 1/2 | 215.9 | 3 | 76.2 | - | - | 10 3/8 | 263.5 | 15.8 |
| 3 | 80 | 8 7/8 | 205.9 | - | - | - | - | 3 | 76.2 | - | - | 11 1/8 | 282.6 | 3 3/4 | 95.3 | - | - | 20 | 508.0 | 36.3 |
| 4 | 100 | 8 11/16 | 220.1 | - | - | - | - | 4 | 101.6 | - | - | 12 | 304.8 | 6 | 152.0 | - | - | 20 | 508.0 | 53.5 |
| 6 | 150 | - | - | - | - | 15 3/4 | 400 | 6 | 152.4 | 10 ¹⁵ / ₁₆ | 278 | 15 7/8 | 403.2 | 5 5/8 | 142.9 | 2.8 | 71 | - | - | 122.0 |
| 8 | 200 | - | - | 17 3/4 | 450.8 | 23 3/8 | 600 | 8 | 203.2 | 12 | 305 | 16 1/2 | 419.1 | 8 | 203.2 | 3.4 | 86 | - | - | 175.0 |

NOTES

Series 300 Soft seat

Size range: Class 150/300 NPS 1/2 - 8 (DN 15 - 200)

1. The type of operator supplied, as standard, for each size of valve is given on page 2.
2. Face to face dimensions (F in table) conform to ASME B16.10 and BS EN 558. Details of standard patterns are given on page 3.
3. Top mounting flange details are given on page 9.
4. Flange dimensions conform to ASME B16.5.

KTM HINDLE ULTRA-SEAL BALL VALVES

SERIES 300

DIMENSIONS SERIES 300 - FULL BORE METAL/CARBON SEATED

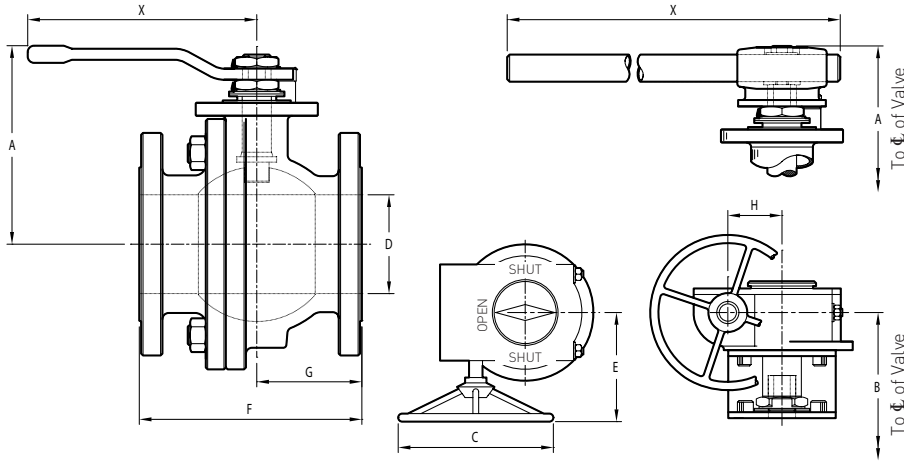

CLASS 150 - MODEL 315FM/315FC

| Size | | A | | B | | C | | D | | E | | F | | G | | H | | X | | Weight |
|-------|-----|---------------------------------|-------|---------------------------------|-------|--------------------------------|-----|-------|-------|----------------------------------|-----|--------------------------------|-------|-------------------------------|-------|-----|----|---------------------------------|-------|--------|
| NPS | DN | in. | mm | in. | mm | in. | mm | in. | mm | in. | mm | in. | mm | in. | mm | in. | mm | in. | mm | kg |
| 1/2 | 15 | 4 ⁷ / ₃₂ | 107.2 | - | - | - | - | 1/2 | 12.7 | - | - | 4 ¹ / ₄ | 108.0 | 1 ³ / ₄ | 44.5 | - | - | 6 ¹ / ₄ | 158.8 | 2.1 |
| 3/4 | 20 | 4 ¹ / ₂ | 114.3 | - | - | - | - | 3/4 | 19.1 | - | - | 4 ⁵ / ₈ | 117.5 | 2 | 50.8 | - | - | 6 ¹ / ₄ | 158.8 | 3.2 |
| 1 | 25 | 4 ¹¹ / ₁₆ | 119.1 | - | - | - | - | 1 | 25.4 | - | - | 5 | 127.0 | 2 | 50.8 | - | - | 6 ¹ / ₄ | 158.8 | 4.0 |
| 1 1/2 | 40 | 5 ⁵ / ₁₆ | 141.3 | - | - | - | - | 1 1/2 | 38.1 | - | - | 6 ¹ / ₂ | 165.1 | 2 ⁵ / ₈ | 67.5 | - | - | 7 ¹¹ / ₁₆ | 195.3 | 7.4 |
| 2 | 50 | 7 ¹ / ₁₆ | 179.4 | - | - | - | - | 2 | 50.8 | - | - | 7 | 177.8 | 3 | 76.2 | - | - | 10 ⁵ / ₈ | 263.5 | 12.9 |
| 3 | 80 | 8 ⁷ / ₈ | 205.9 | - | - | - | - | 3 | 76.2 | - | - | 8 | 203.2 | 3 ³ / ₄ | 95.3 | - | - | 20 | 508.0 | 27.3 |
| 4 | 100 | - | - | 10 ¹ / ₂ | 266.7 | 15 ³ / ₄ | 400 | 4 | 101.6 | 10 ¹⁵ / ₁₆ | 278 | 9 | 228.6 | 4 ¹ / ₄ | 108.0 | 2.8 | 71 | - | - | 52.5 |
| 6 | 150 | - | - | 12 ⁵ / ₁₆ | 313 | 29 ¹ / ₂ | 750 | 6 | 152.4 | 12 | 305 | 10 ¹ / ₂ | 266.7 | 5 ¹ / ₄ | 133.4 | 3.4 | 86 | - | - | 95.2 |

CLASS 300 - MODEL 330FM/330FC

| Size | | A | | B | | C | | D | | E | | F | | G | | H | | X | | Weight |
|-------|-----|---------------------------------|-------|---------------------------------|-------|----------------------------------|-----|-------|-------|---------------------------------|-----|--------------------------------|-------|-------------------------------|-------|-----|-----|---------------------------------|-------|--------|
| NPS | DN | in. | mm | in. | mm | in. | mm | in. | mm | in. | mm | in. | mm | in. | mm | in. | mm | in. | mm | kg |
| 1/2 | 15 | 4 ⁷ / ₃₂ | 107.2 | - | - | - | - | 1/2 | 12.7 | - | - | 5 ¹ / ₂ | 139.7 | 1 ⁷ / ₈ | 47.6 | - | - | 6 ¹ / ₄ | 158.8 | 2.6 |
| 3/4 | 20 | 4 ¹ / ₂ | 114.3 | - | - | - | - | 3/4 | 19.1 | - | - | 6 | 152.4 | 2 ¹ / ₄ | 57.2 | - | - | 6 ¹ / ₄ | 158.8 | 4.3 |
| 1 | 25 | 4 ¹¹ / ₁₆ | 119.1 | - | - | - | - | 1 | 25.4 | - | - | 6 ¹ / ₂ | 165.1 | 2 ⁵ / ₈ | 66.7 | - | - | 6 ¹ / ₄ | 158.8 | 5.8 |
| 1 1/2 | 40 | 5 ⁵ / ₁₆ | 141.3 | - | - | - | - | 1 1/2 | 38.1 | - | - | 7 ¹ / ₂ | 190.5 | 2 ⁵ / ₈ | 66.7 | - | - | 7 ¹¹ / ₁₆ | 195.3 | 10.7 |
| 2 | 50 | 7 ¹ / ₁₆ | 179.4 | - | - | - | - | 2 | 50.8 | - | - | 8 ¹ / ₂ | 215.9 | 3 | 76.2 | - | - | 10 ⁵ / ₈ | 263.5 | 15.8 |
| 3 | 80 | - | - | 9 ⁷ / ₈ | 250.8 | 11 ¹³ / ₁₆ | 300 | 3 | 76.2 | 10 | 254 | 11 ¹ / ₈ | 282.6 | 3 ³ / ₄ | 95.3 | 2.8 | 71 | - | - | 46.3 |
| 4 | 100 | - | - | 10 ¹ / ₂ | 266.7 | 19 ¹¹ / ₁₆ | 500 | 4 | 101.6 | 11 ⁵ / ₁₆ | 288 | 12 | 304.8 | 6 | 152.0 | 2.8 | 71 | - | - | 122.0 |
| 6 | 150 | - | - | 12 ⁵ / ₁₆ | 313.0 | 23 ⁵ / ₈ | 600 | 6 | 152.4 | 15 ¹ / ₄ | 387 | 15 ⁵ / ₈ | 403.2 | 5 ⁵ / ₈ | 142.9 | 5.1 | 130 | - | - | 175.0 |

NOTES

Series 300 Metal/Carbon seat

Size range: Class 150/300 NPS 1/2 - 6 (DN 15 - 150)

1. The type of operator supplied as standard for each size of valve is given on page 2.
2. Face to face dimensions (F in table) conform to ASME B16.10 and BS EN 558. Details of standard patterns are given on page 3.
3. Top mounting flange details are given on page 9.
4. Flange dimensions conform to ASME B16.5.

KTM HINDLE ULTRA-SEAL BALL VALVES

SERIES 300

TOPWORKS DIMENSIONS

| Valve size | | | A | | B | | C | | D | | E | | F | | G |
|------------|-------|-----------------|------------|-------|----|-------|-------|-------|-------|-------|-----|-------|--------|-----|---|
| DN | NPS | ISO flange type | mm | inch | mm | inch | mm | inch | mm | inch | mm | inch | mm | | |
| 15 | 1/2 | F03 | M12 x 1.25 | 0.787 | 20 | 0.315 | 8.00 | 0.437 | 11.00 | 0.078 | 2.0 | 0.984 | 25.00 | M5 | |
| | | | | | | 0.313 | 7.92 | | | | | 0.974 | 24.75 | | |
| 20 | 3/4 | F04 | M14 x 1.25 | 0.984 | 25 | 0.374 | 9.50 | 0.600 | 15.25 | 0.078 | 2.0 | 1.181 | 30.00 | M5 | |
| | | | | | | 0.372 | 9.45 | | | | | 1.171 | 29.75 | | |
| 25 | 1 | F04 | M14 x 1.25 | 0.984 | 25 | 0.374 | 9.50 | 0.600 | 15.25 | 0.078 | 2.0 | 1.181 | 30.00 | M5 | |
| | | | | | | 0.372 | 9.45 | | | | | 1.171 | 29.75 | | |
| 40 | 1 1/2 | F05 | M18 x 1.5 | 1.300 | 33 | 0.472 | 12.00 | 0.787 | 20.00 | 0.060 | 1.5 | 1.378 | 35.00 | M6 | |
| | | | | | | 0.470 | 11.95 | | | | | 1.368 | 34.75 | | |
| 50 | 2 | F07 | M22 x 1.5 | 1.338 | 34 | 0.590 | 15.00 | 0.837 | 21.25 | 0.060 | 1.5 | 2.171 | 55.00 | M8 | |
| | | | | | | 0.588 | 14.95 | | | | | 2.161 | 54.75 | | |
| 80 | 3 | F10 | M28 x 1.5 | 1.650 | 42 | 0.748 | 19.00 | 1.075 | 27.30 | 0.090 | 2.3 | 2.760 | 70.00 | M10 | |
| | | | | | | 0.746 | 18.95 | | | | | 2.750 | 69.75 | | |
| 100 | 4 | F10 | M28 x 1.5 | 1.650 | 42 | 0.748 | 19.00 | 1.075 | 27.30 | 0.090 | 2.3 | 2.760 | 70.00 | M10 | |
| | | | | | | 0.746 | 18.95 | | | | | 2.750 | 69.75 | | |
| 150 | 6 | F12 | M36 x 1.5 | 2.200 | 56 | 0.945 | 24.00 | 1.400 | 35.60 | 0.090 | 2.3 | 3.345 | 85.00 | M12 | |
| | | | | | | 0.945 | 23.95 | | | | | 3.335 | 84.75 | | |
| 200 | 8 | F16 | M60 x 1.5 | 3.386 | 86 | 1.813 | 46.00 | 2.165 | 55.00 | 0.090 | 2.3 | 5.123 | 130.00 | M20 | |
| | | | | | | 1.810 | 45.95 | | | | | 5.113 | 129.75 | | |

TOPWORKS DIMENSIONS

| Valve size | | | H | | J | | K | | L | | N | |
|------------|-------|-----------------|-------|-------|-------|-------|-------|-------|-------|-------|-------|-------|
| DN | NPS | ISO flange type | inch | mm | inch | mm | inch | mm | inch | mm | inch | mm |
| 15 | 1/2 | F03 | 0.250 | 6.35 | 1.417 | 36.0 | 1.142 | 29.0 | 1.875 | 47.6 | 1.375 | 34.9 |
| 20 | 3/4 | F04 | 0.315 | 8.00 | 1.654 | 42.0 | 1.322 | 33.6 | 2.125 | 54.0 | 1.560 | 39.6 |
| 25 | 1 | F04 | 0.315 | 8.00 | 1.654 | 42.0 | 1.516 | 38.5 | 2.125 | 54.0 | 1.750 | 44.5 |
| 40 | 1 1/2 | F05 | 0.315 | 8.00 | 1.969 | 50.0 | 2.258 | 57.3 | 2.500 | 63.5 | 1.875 | 47.6 |
| 50 | 2 | F07 | 0.503 | 12.75 | 2.756 | 70.0 | 3.818 | 97.0 | 3.563 | 90.5 | 2.750 | 69.9 |
| 80 | 3 | F10 | 0.535 | 13.60 | 4.016 | 102.0 | 5.097 | 129.5 | 4.938 | 125.4 | 3.875 | 98.4 |
| 100 | 4 | F10 | 0.535 | 13.60 | 4.016 | 102.0 | 5.723 | 145.4 | 4.938 | 125.4 | 4.938 | 125.4 |
| 150 | 6 | F12 | 0.723 | 18.35 | 4.921 | 125.0 | 7.535 | 191.4 | 6.000 | 152.4 | 6.000 | 152.4 |
| 200 | 8 | F16 | 1.000 | 25.40 | 6.496 | 165.0 | 10.16 | 258.0 | 8.250 | 209.6 | 8.250 | 209.6 |

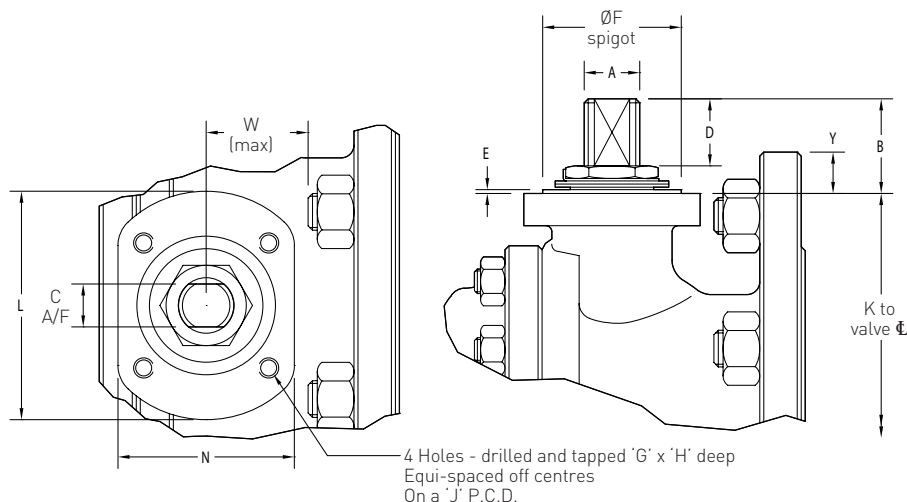

NOTES

- Dimensions Y and Z are only applicable when height of the mounting flange falls below top of flange (as shown). Only these valve sizes are affected. Dimension W is based on bolting to ASME B18.2.2 heavy hex nuts.

DIMENSIONS

| Valve size | | | Y | | W | |
|------------|-------|------|-------|------|-------|------|
| DN | NPS | Type | inch | mm | inch | mm |
| 15 | 1/2 | 315 | 0.608 | 15.4 | 0.649 | 16.5 |
| 15 | 1/2 | 330 | 0.733 | 18.6 | 0.721 | 18.3 |
| 20 | 3/4 | 315 | 0.616 | 15.7 | 0.783 | 19.9 |
| 20 | 3/4 | 330 | 0.991 | 25.2 | 0.814 | 20.7 |
| 25 | 1 | 315 | 0.609 | 15.5 | 0.975 | 24.8 |
| 25 | 1 | 330 | 0.922 | 23.4 | 1.051 | 26.7 |
| 40 | 1 1/2 | 315 | 0.248 | 6.3 | 1.438 | 36.5 |
| 40 | 1 1/2 | 330 | 0.811 | 20.6 | 0.885 | 22.5 |

KTM HINDLE ULTRA-SEAL BALL VALVES

SERIES 300

PRINCIPAL COMPONENTS

| No. | Component | Carbon steel valves | Stainless steel valves |
|-------|--------------------------|---|---|
| 1 | Body | ASTM A216 WCB ^[1] | ASTM A351 CF8M |
| 2 | Connector | ASTM A216 WCB ^[1] | ASTM A351 CF8M |
| 7 | Ball ^[3, 4] | 316 / 316L Stainless steel | 316 / 316L Stainless steel |
| 7 | Ball ^[5] | AISI 316Ti (with hard metal alloy coating) | AISI 316Ti (with hard metal alloy coating) |
| 8 | Shaft | 316 / 316L Stainless steel | 316 / 316L Stainless steel |
| 8 | Shaft ^[4, 5] | 17-4 PH | 17-4 PH (alternative XM19) |
| 21 | Gland collar | 316 / 316L Stainless steel | 316 / 316L Stainless steel |
| 24/25 | Seat ring ^[3] | Virgin PTFE | Virgin PTFE |
| 24/25 | Seat ring ^[4] | 316 / 316L Stainless steel (with carbon insert) | 316 / 316L Stainless steel (with carbon insert) |
| 24/25 | Seat ring ^[5] | AISI 316Ti (with hard metal alloy coating) | AISI 316Ti (with hard metal alloy coating) |
| 50 | Body studbolt | ASTM A193-B7 | ASTM A193-B8 |
| 51 | Body nut | ASTM A194-2H | ASTM A 194-8 |

OTHER COMPONENTS

Materials which are common for both carbon steel and stainless steel valves

| No. | Component | Material |
|-----|--|--|
| 22 | Anti-static ball | ASTM A276-316 |
| 23 | Anti-static spring | ASTM B164 MONEL 400 |
| 26 | Connector seat energizer ^[4, 5] | ASTM A276-316 / 316L |
| 27 | Seat spring | ASTM A313-631 17-7 PH (up to 350°C) / Alloy A 286 (up to 450°C) |
| 29 | Gland spring | 17-7 PH Stainless steel (up to 350°C) Inconel (above 350°C) |
| 30 | Shaft nut | ASTM A240-304H |
| 31 | Tab washer | ASTM A240-304H |
| 60 | Body primary seal ^[3] | PTFE |
| 60 | Body primary seal ^[4, 5] | Flexible graphite |
| 65 | Shaft primary seal | 25% GF PTFE ^[3] , flexible graphite ^[4, 5] |
| 70 | Body fire seal ^[3] | PTFE |
| 70 | Body fire seal ^[4, 5] | Flexible graphite |
| 75 | Shaft fire seal | Flexible graphite |
| 76 | Body seat seal ^[4, 5] | Flexible graphite |
| 77 | Connector seat seal ^[4, 5] | Flexible graphite |
| 90 | Handlever ^[2] | ASTM A276-304 |
| 93 | Stop collar screw ^[2] | A2-70 |
| 94 | Stop collar | Brass, nickel plated |
| 96 | Gearbox ^[2] | Commercial |
| 97 | Mounting bracket ^[2] | Stainless steel |
| 98 | Gearbox screw ^[2] | A2-70 |
| 99 | Bracket screw ^[2] | A2-70 |
| 100 | Coupling ^[2] | Stainless steel |
| 102 | Handwheel ^[2] | Carbon steel |
| 104 | T-Bar adapter ^[2] | ASTM A351 CF8M |
| 105 | T-Bar tube ^[2] | ASTM A573-70 |
| 106 | T-Bar washer ^[2] | ASTM A240-304H |
| 107 | T-Bar screw ^[2] | A2-70 |

ALTERNATIVE MATERIALS

| Body and trim |
|---------------------------------------|
| Low carbon steel - LCC |
| Duplex stainless steel |
| Aluminium bronze |
| Monel |
| Other materials available on request. |
| Seats |
| Reinforced PTFE |
| Carbon filled PTFE |
| TFM 1600 |
| Carbon graphite filled PEEK™ |
| Accessories |
| Actuation controls |
| Locking devices |
| Lagging extensions |

NOTES

1. Max. carbon content 0.25%.
 2. Operator type varies by size (see pages 2).
 3. Soft seated valves.
 4. Carbon seated valves.
 5. Metal seated valves.
- Certification is available on standard production, as follows:
- hydrostatic body and seat test.
 - pneumatic seat test.
 - material (chemical and physical) to BS EN 10204 - 3.1.

KTM HINDLE ULTRA-SEAL BALL VALVES

SERIES 300

PRINCIPAL COMPONENTS

| Coating type | Description | Coating thickness | Coating hardness | Temp. limit |
|--------------|---------------------------|-------------------|------------------|-------------|
| HTN-60 | Nickel alloy coating | 500 micron | 60 HRc | 450°C |
| | Flame spraying and fusing | | | |
| HTC-70 | Chromium carbide coating | 200 micron | 70 HRc | 450°C |
| | HVOF spray | | | |
| HTT-75 | Tungsten carbide coating | 200 micron | 75 HRc approx. | 350°C |
| | HVOF spray | | | |

CARBON GRAPHITE MATERIAL

| Carbon graphite type | Description | Density | Coefficient of thermal expansion | Temp. limit |
|----------------------|---|---|----------------------------------|-------------|
| HTCG | Hard carbon graphite A strong antimony impregnated carbon graphite. Suitable for clean organic solvents and purified terephthalic acid (PTA). | 2.50 x 10 ³ kg.m ⁻³ | 4.7 x 10 ⁻⁶ °C | 300°C |

STANDARD PAINT/FINISH

Carbon steel valves

Red oxide primer

Stainless steel valves

Castings are acid pickled and passivated to remove surface impurities.

Paint finishes

A range of painting specifications for offshore and onshore service conditions are available to customer requirements.

GRAPH LINE IDENTIFICATION

| Size NPS (DN) | Seat material | |
|------------------|---------------|------|
| | PTFE | RTFE |
| ½ - 2 (15 - 50) | B | A |
| 3 - 6 (80 - 150) | C | A |
| 8 (200) | D | C |

PRESSURE/TEMPERATURE GRAPH

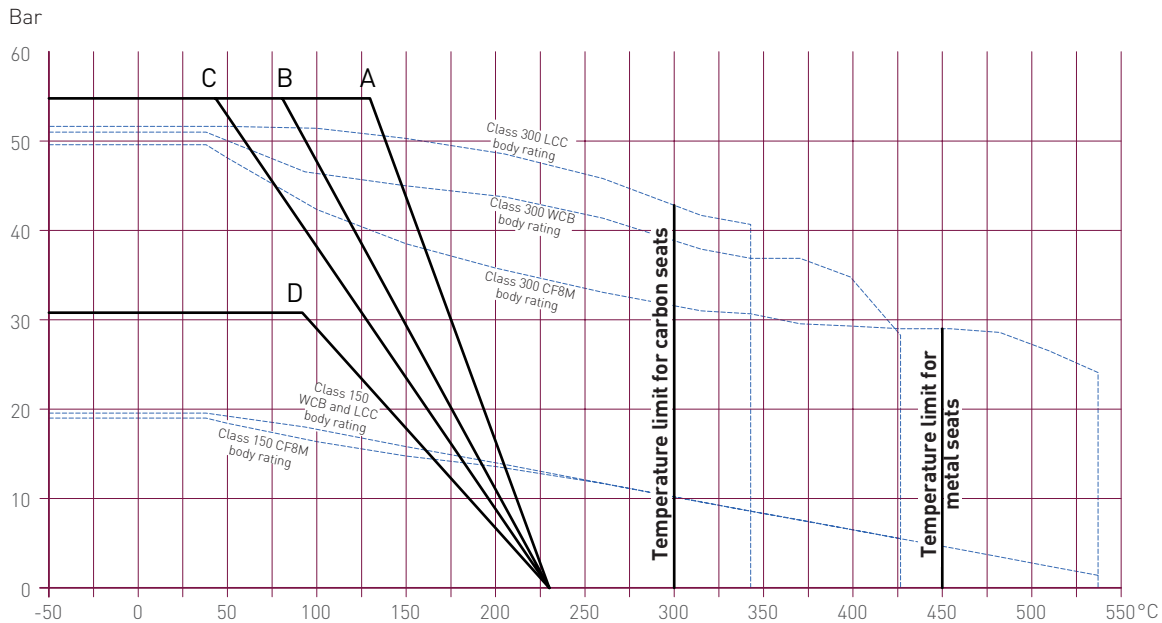

NOTES

- The maximum working capability of any given valve is either the body rating or seat rating, whichever is the lower.
- The graph line identification table indicates the valve seat materials represented by lines A to D on the graph.
- For metal and carbon seats use the maximum body ratings. Carbon seats can only achieve 300 °C max.

KTM HINDLE ULTRA-SEAL BALL VALVES

SERIES 300

C_v/K_v - VALUES

| Valve size | | Class 150 | | Class 300 | |
|------------|-----|----------------|----------------|----------------|----------------|
| NPS | DN | C _v | K _v | C _v | K _v |
| 1/2 | 15 | 20 | 17 | 17 | 15 |
| 3/4 | 20 | 34 | 29 | 34 | 29 |
| 1 | 25 | 140 | 121 | 132 | 114 |
| 1 1/2 | 40 | 281 | 243 | 265 | 229 |
| 2 | 50 | 511 | 442 | 470 | 407 |
| 3 | 80 | 1380 | 1194 | 1200 | 1038 |
| 4 | 100 | 2200 | 1903 | 2210 | 1912 |
| 6 | 150 | 5400 | 4671 | 5400 | 4671 |
| 8 | 200 | 10660 | 9221 | 10660 | 9221 |

NOTES

1. Flow coefficients are for valves in the fully open position.
2. Ultra-Seal ball valve models are categorised by a four part code indicating design type, ball and seat, flange drilling and body material to show example given (315FM-15-316).
3. Other flange drillings available on request.
4. Trim and other component materials for standard valves are given on page 10.

VALVE CODING SYSTEM

Individual model numbers are derived from a combination of:

- Design series number (300)
- Design pressure class (150, 300)
- Ball and seat design (F, FM, FC)
- Flange drilling (ASME 150, 300)
- Body material (161, 316)

SELECTION GUIDE

| Example: | 3 | 15 | FM | 15 | 316 |
|-------------------------|--------------------------------|----|----|----|-----|
| Series | 3 | | | | |
| 3 | 300 | | | | |
| Class | | 15 | | | |
| 15 | 150 | | | | |
| 30 | 300 | | | | |
| Ball/seat design | | | FM | | |
| F | Full bore soft | | | | |
| FM | Full bore metal | | | | |
| FC | Full bore carbon seats | | | | |
| Flange drilling | | | | 15 | |
| 15 | ASME 150 | | | | |
| 30 | ASME 300 | | | | |
| Body material | | | | | 316 |
| 316 | Stainless steel ASTM A351 CF8M | | | | |
| 161 | Carbon steel ASTM A216 WCB | | | | |
| LCC | Carbon steel ASTM A352 LCC | | | | |
| AB2 | Aluminium bronze BS1400 AB2 | | | | |
| DUP | Duplex stainless steels | | | | |

Neither Emerson, Emerson Automation Solutions, nor any of their affiliated entities assumes responsibility for the selection, use or maintenance of any product. Responsibility for proper selection, use, and maintenance of any product remains solely with the purchaser and end user.

KTM is a mark owned by one of the companies in the Emerson Automation Solutions business unit of Emerson Electric Co. Emerson Automation Solutions, Emerson and the Emerson logo are trademarks and service marks of Emerson Electric Co. All other marks are the property of their respective owners.

The contents of this publication are presented for informational purposes only, and while every effort has been made to ensure their accuracy, they are not to be construed as warranties or guarantees, express or implied, regarding the products or services described herein or their use or applicability. All sales are governed by our terms and conditions, which are available upon request. We reserve the right to modify or improve the designs or specifications of such products at any time without notice.

Emerson.com/FinalControl