

Application Considerations for an Instrumentation Lowpass Filter

Nello Sevastopoulos

Description

The LTC[®]1062 is a versatile, DC accurate, instrumentation lowpass filter with gain and phase that closely approximate a 5th order Butterworth filter. The LTC1062 is quite different from presently available lowpass switched-capacitor filters because it uses an external (R, C) to isolate the IC from the input signal DC path, thus providing DC accuracy. Figure 1 illustrates the architecture of the circuit. The output voltage is sensed through an internal buffer, then applied to an internal switched-capacitor network which drives the bottom plate of an external capacitor to form an input-to-output 5th order lowpass filter. The input and output appear across an external resistor and the IC part of the overall filter handles only the AC path of the signal. A buffered output is also provided (Figure 1) and its maximum guaranteed offset voltage over temperature is 20mV. Typically the buffered output offset is 0mV to 5mV and drift is 1 μ V/°C. As will be explained later, the use of an input (R, C) provides other advantages, namely lower noise and antialiasing.

Tuning the LTC1062

Choosing the external (R, C)

In Figure 1, the filter function is formed by using an external (R, C) to place the LTC1062 inside an AC loop. Because

of this, the value of the (R • C) product is critically related to the filter passband flatness and to the filter stability. The internal circuitry of the LTC1062 is driven by a clock which also determines the filter cutoff frequency. For a maximally flat amplitude response, the clock should be 100 times the desired cutoff frequency and the (R, C) should be chosen such as:

$$\frac{f_c}{1.62} \leq \frac{1}{2\pi RC} \leq \frac{f_c}{1.63}$$

where:

f_c = filter cutoff frequency, (–3dB point).

For instance, to make a maximally flat filter with a –3dB frequency at 10Hz, we need a 100 • 10Hz = 1kHz internal or external clock and an external (R, C) such as:

$$\frac{1}{2\pi RC} = \frac{10\text{Hz}}{1.62} = 6.17\text{Hz}$$

The minimum value of the resistor, R, depends upon the maximum signal we want to attenuate, and the current sinking capability of Pin 1 which is typically 1mA. The 10Hz filter of the previous example should attenuate a 40Hz signal by 60dB. If the instantaneous amplitude of this signal is 1V peak, the minimum value of the external resistor should be 1k Ω .

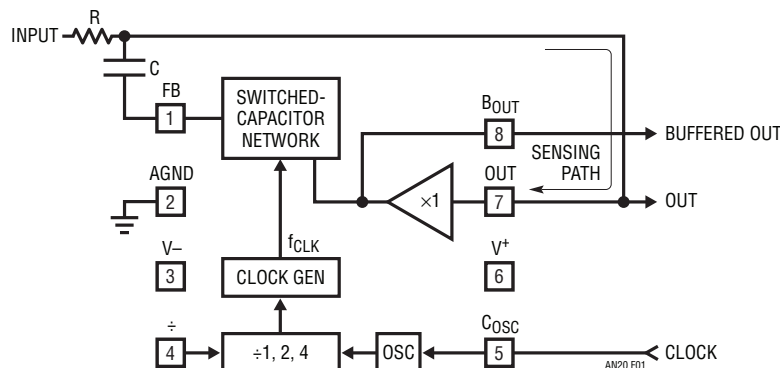

Figure 1. LTC1062 Architecture

an20f

Application Note 20

Figure 2 shows the high accuracy of the passband response for values of $1/2\pi RC$ around ($f_c/1.62$). If maximum flatness is required, the $(R \cdot C)$ product should be well controlled. Figures 3 and 4 are similar to Figure 2 but with wider range of $(1/2\pi RC)$ values. When the input (R, C) cutoff frequency approaches the cutoff frequency of the filter, the filter peaks and the circuit may become oscillatory. This can accidentally happen when using input ceramic capacitors with strong negative temperature coefficient. As the temperature increases, the value of the external capacitor decreases and if the clock driving the LTC1062 stays constant, the resulting $(1/2\pi RC)$ approaches the filter cutoff frequency. On the other hand, if the external $(R \cdot C)$ has a strong positive temperature coefficient, the filter passband at high temperatures will become droopy. It is important to note that the filter attenuation slope is mainly set by the internal LTC1062 circuitry and it is quasi-independent from the values of the external (R, C) . This is shown in Figure 4, where a 100Hz cutoff frequency LTC1062 was tested with an external 10kHz clock and for:

$$\frac{f_c}{3.24} \leq \frac{1}{2\pi RC} \leq \frac{f_c}{1.13}$$

Also, Figure 4 shows that the -30dB/octave slope remains constant even though the external $(R \cdot C)$ changes.

LTC1062 Clock Requirements

Using an external clock: the internal switched-capacitor network is clock driven and the clock frequency should be 100 times the desired filter cutoff frequency. Pin 5 of the LTC1062 is the clock input and an external clock swinging close to the LTC1062 power supplies will provide the clock requirements for the internal circuitry. The typical logic threshold levels of Pin 5 are the following:

V_{SUPPLY}	V_{th^+}	V_{th^-}
$\pm 2.5\text{V}$	+0.9V	-1V
$\pm 5\text{V}$	+1.3V	-2.1V
$\pm 6\text{V}$	+1.7V	-2.5V
$\pm 7\text{V}$	+1.75V	-2.9V
$\pm 8\text{V}$	+1.95V	-3.3V
$\pm 9\text{V}$	+2.15V	-3.7V

The temperature coefficient of the threshold levels is $-1\text{mV}/^\circ\text{C}$.

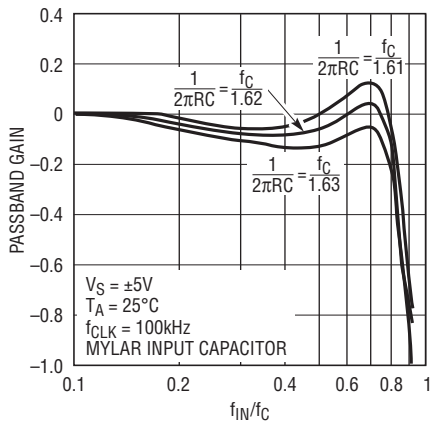

Figure 2. Passband Gain vs Input Frequency

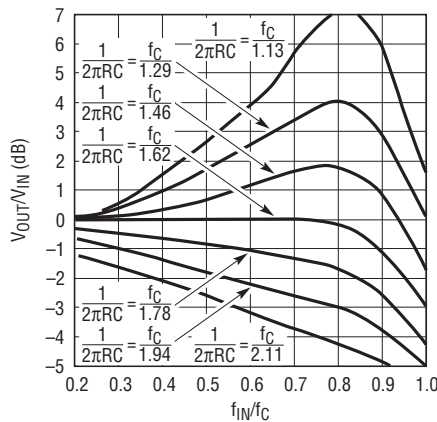

Figure 3. Passband Gain vs Input Frequency

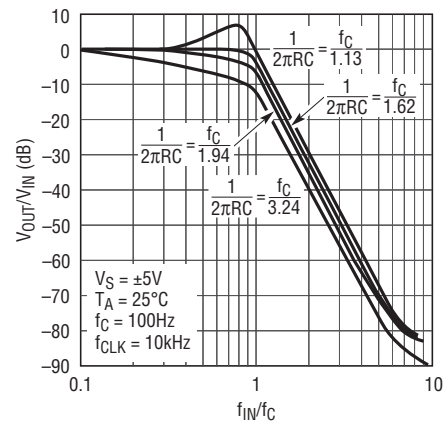

Figure 4. Filter Frequency Response for Various (R, C) Values and Constant Clock

Because the trip levels of Pin 5 are asymmetrically centered around ground and because $(V_{th}^+ - V_{th}^-)$ is less than the positive supply voltage, V^+ , CMOS level clocks operating from V^+ and ground can be AC coupled into Pin 5 and drive the IC, Figure 5a.

Internal Oscillator

A simple oscillator is internally provided and it is overridden when an external clock is applied to Pin 5. The internal oscillator can be used for applications for clock requirements below 130kHz and where maximum passband flatness over a wide temperature range is not required. The internal oscillator can be tuned for frequencies below 130kHz by connecting an external capacitor, C_{OSC} , from Pin 5 to ground (or negative supply). Under this condition, the clock frequency can be calculated by:

$$f_{CLK} \cong 130\text{kHz} \left(\frac{33\text{pF}}{33\text{pF} + C_{OSC}} \right) \quad (1)$$

Due to process tolerances, the internal 130kHz frequency varies and also has a negative temperature coefficient. The LTC1062 data sheet publishes curves characterizing the internal oscillator. To tune the frequency of the internal oscillator to a precise value, it is necessary to adjust the value of the external capacitor, C_{OSC} , or to use a potentiometer in series with the C_{OSC} , Figure 5b. The new clock frequency, f'_{CLK} , can be calculated by:

$$f'_{CLK} = \frac{f_{CLK}}{(1 - 4RC_{OSC}f_{CLK})} \quad (2)$$

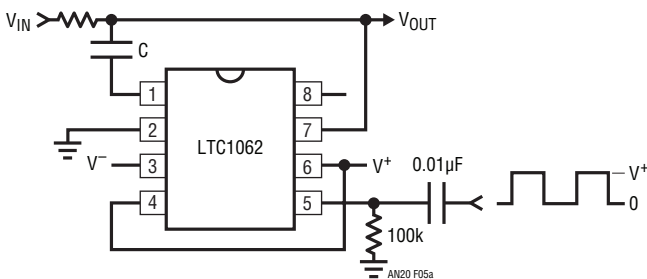

Figure 5a. AC Coupling an External CMOS Clock Powered from a Single Positive Supply, V^+

where f_{CLK} is the value of the clock frequency, when $R = 0$, from (1). When an external resistor (potentiometer) is used, the new value of the clock frequency is always higher than the one calculated in (1). To achieve a wide tuning range, calculate from (1) the ideal (f_{CLK}, C_{OSC}) pair, then double the value of C_{OSC} and use a 50k potentiometer to adjust f'_{CLK} .

Example: To obtain a 1kHz clock frequency, from (1) C_{OSC} typically should be 4250pF. By using 8500pF for C_{OSC} and a 50k potentiometer, the clock frequency can be adjusted from 500Hz to 3.3kHz as calculated by (2).

The internal oscillator frequency can be measured directly at Pin 5 by using a low capacitance probe.

Clock Feedthrough

Clock feedthrough is defined as the amount of clock frequency appearing at the output of the filter. With $\pm 5\text{V}$ supplies the measured clock feedthrough was $420\mu\text{V}_{RMS}$, while with $\pm 7.5\text{V}$ supplies it increased to $520\mu\text{V}_{RMS}$. The clock feedthrough can be eliminated by using an (R, C) at the buffered output, Pin 8, provided that this pin is used as an output. If an external op amp is used to buffer the DC accurate output of the LTC1062, an input (R, C) can be used to eliminate the clock feedthrough, Figure 6, and to further increase the attenuation floor of the filter. Note that this (R, C) does not really improve the noise floor of the circuit since the major noise components are located near the filter cutoff frequency.

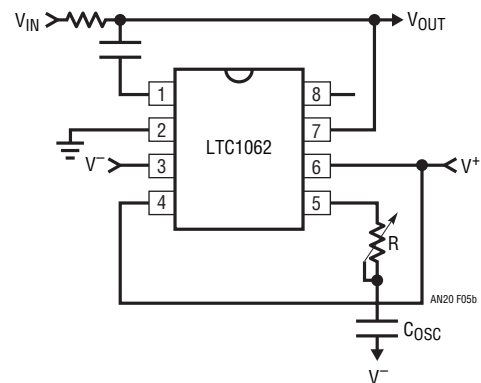

Figure 5b. Adding a Resistor in Series with C_{OSC} to Adjust the Internal Clock Frequency

Application Note 20

Single 5V Supply Operation

Figure 7 shows the LTC1062 operating with a single supply. The analog ground, Pin 2, as well as the buffer input, Pin 7, should be biased at 1/2 supply. The value of resistor R1 should conduct 100 μ A or more. In Figure 7, the resistor R' DC biases the buffer and the capacitor C' isolates the buffer bias from the DC value of the output. Under these conditions the external (R, C) should be adjusted such that $(1/2\pi RC) = f_c/1.84$. This accounts for the extra AC loading of the (R', C') combination.

The resistor and capacitor (R', C') are not needed if the input voltage has a DC value around 1/2 supply.

If an external capacitor is used to activate the internal oscillator, its bottom plate should be tied to system ground.

Dynamic Range and Signal/Noise Ratio

There is some confusion with these two terminologies. Because monolithic switched-capacitor filters are inherently more noisy than (R, C) active filters, it is necessary to take a hard look at the way some IC manufacturers describe the S/N ratio of their circuit. For instance, when dividing the filter's typical RMS swing by its wideband noise, the result is called "best case" S/N ratio. But this is definitely not "dynamic range". Under max swing conditions, many monolithic filters exhibit high harmonic distortion. This indicates poor dynamic range even though the S/N ratio looks great on paper.

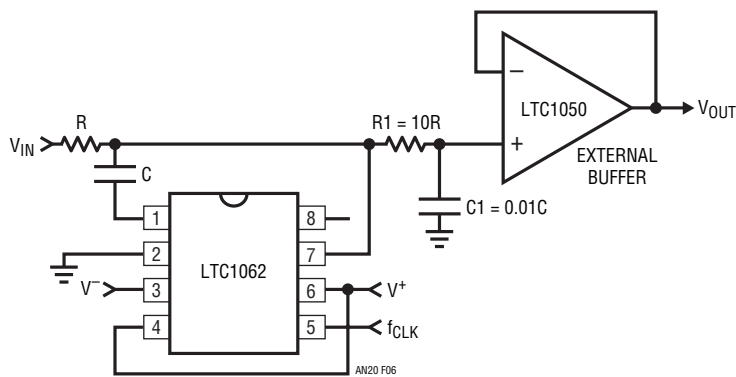

Figure 6. Adding an External (R1, C1) to Eliminate the Clock Feedthrough and to Improve the High Frequency Attenuation Floor

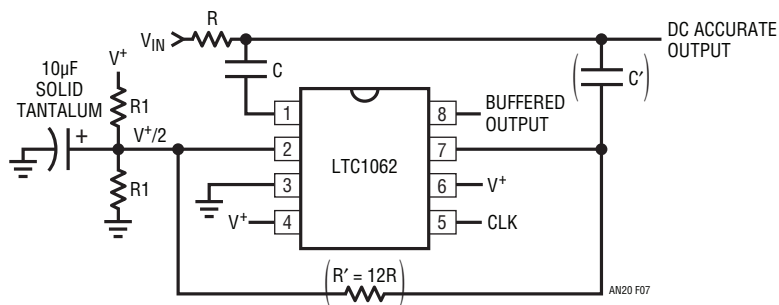

Figure 7. Single Supply Operation

With $\pm 5V$ supplies and higher, the LTC1062 has a typical $100\mu V_{RMS}$ wideband noise. With $1V_{RMS}$ output levels, the signal/noise ratio is 80dB. The test circuit of Figure 8 is used to illustrate the harmonic distortion of the device. The worst-case occurs when the input fundamental frequency equals 1/2 or 1/3 of the filter cutoff frequency. This causes the 2nd or 3rd harmonics of the output to fall into the filter's passband edge, Figures 9a and 9b.

Figure 9c shows an input frequency of 700Hz and the filter's dynamic range under this condition is in excess of

80dB. This is true because the harmonics of the 700Hz input fall into the filter's stopband. With $\pm 7.5V$ supplies (or single 15V), the THD of the LTC1062 lies between 76dB and 83dB, depending on where the harmonics occur with respect to the circuit's band edge. A slight improvement, Figure 9d, can be achieved by increasing the value of the input resistor, R, such as $(1/2\pi RC) = f_C/1.93$. Under this condition, the filter no longer approximates a max flat ideal response since it becomes "droopy" above 30% of its cutoff frequency, as shown in Figure 3.

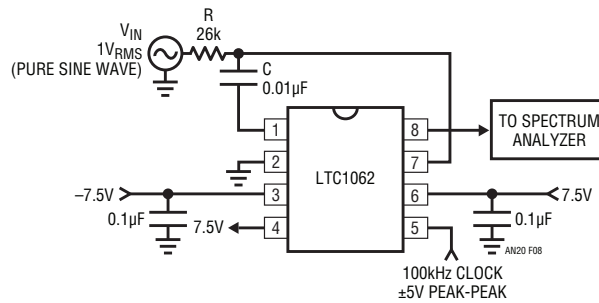

Figure 8. 1kHz Cutoff Frequency, 5th Order LP Filter, Test Circuit for Observing Distortion

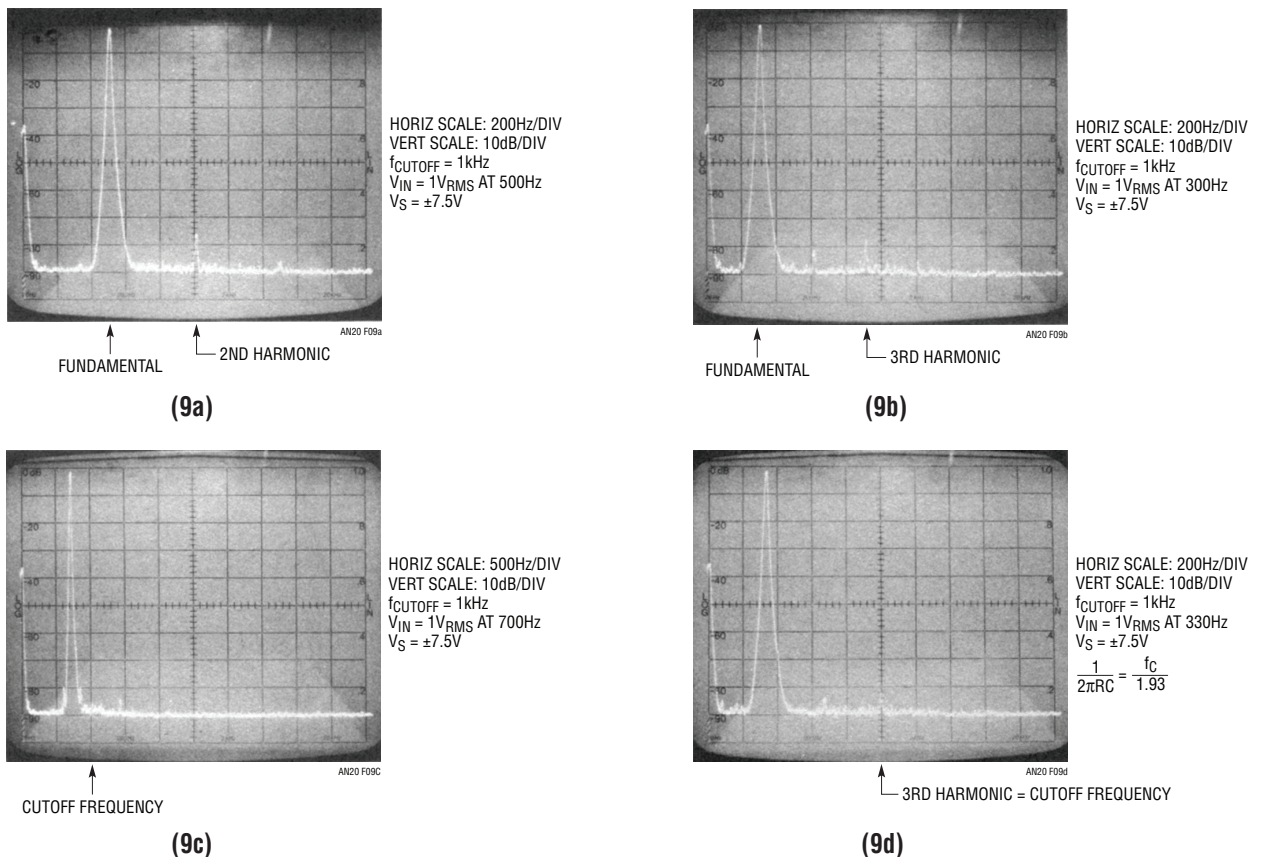

Figure 9

Application Note 20

Step Response and Burst Response

The LTC1062 response to an input step approximates that of an ideal 5th order Butterworth lowpass filter. Butterworth filters are “ringy”, Figure 10a, even though their passband is maximally flat. Figures 10b and 10c show a more damped step response which can be obtained by increasing the input (R•C) product and thereby sacrificing the maximum flatness of the filter’s amplitude response. Figures 11a and 11b show the response of the LTC1062 to a 2V peak-to-peak sinewave burst which frequency is respectively equal to $2 \cdot f_C$ and $4 \cdot f_C$. It is interesting to compare Figure 11b to Figure 10a: In both figures the overshoots and the settling times are about equal since, from the filter’s point of view, a high frequency burst looks like a step input.

LTC1062 Shows Little Aliasing

Aliasing is a common phenomenon in sampled data circuits especially when signals approaching the sampling frequency are applied as inputs. Generally speaking, when an input signal of frequency (f_{IN}) is applied, an alias frequency equal to ($f_{CLK} \pm f_{IN}$) appears at the filter’s output. If f_{IN} is less than ($f_{CLK}/2$), then the amplitude of the alias frequency equals the magnitude of f_{IN} multiplied by the gain of the filter at f_{IN} , times the ($\sin x/x$) function of the circuit. For a lowpass filter, the gain around ($f_{CLK}/2$) is essentially limited by the attenuation floor of the filter and the ($f_{CLK} \pm f_{IN}$) alias signal is buried into the filter noise floor. The problem arises when the input signal’s frequency is greater than ($f_{CLK}/2$) and especially when it approaches f_{CLK} . Under these conditions ($f_{CLK} - f_{IN}$) falls either into

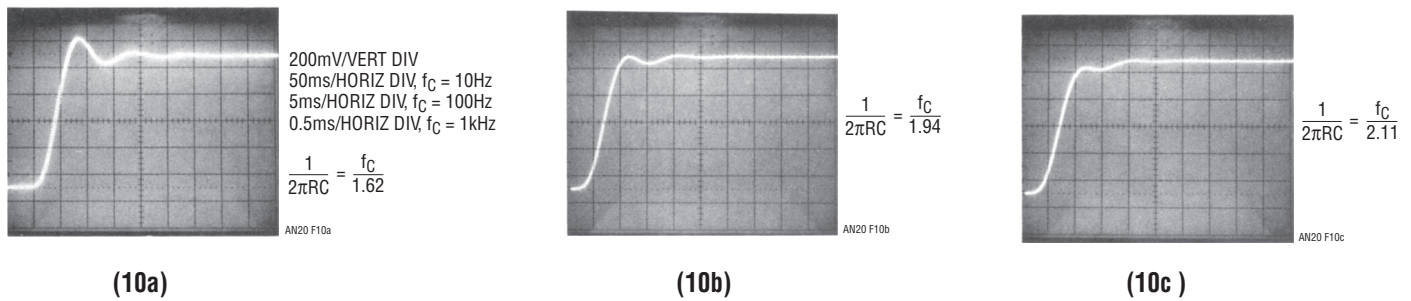

Figure 10. Step Response to a 1V Peak Input Step

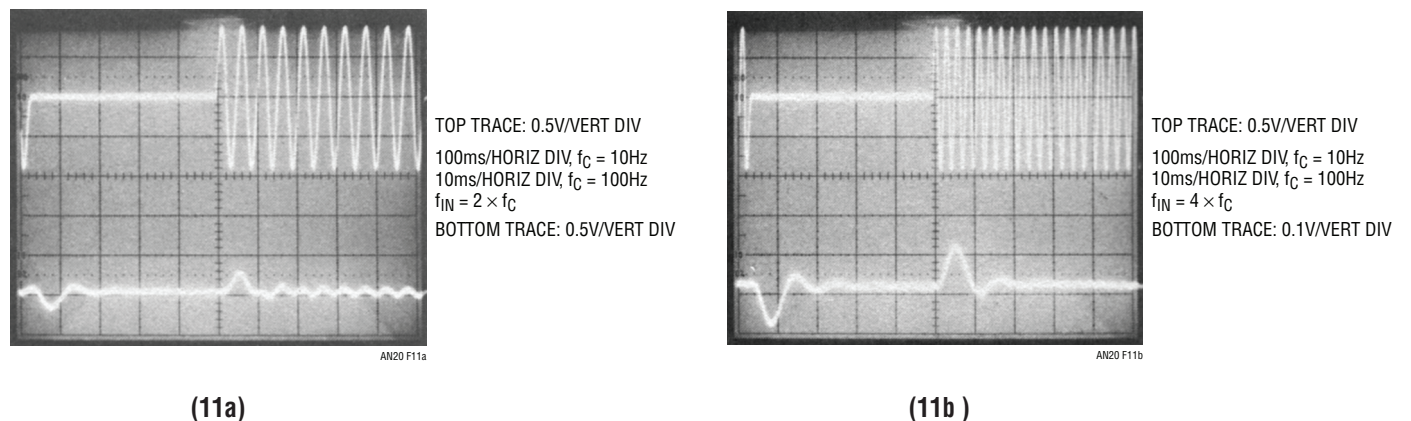

Figure 11. LTC1062 Response to a 2V_{p-p} Sinewave Burst

the filters passband or into the attenuation slope, and then aliasing occurs. If for instance a 5th order Butterworth switched-capacitor ladder filter has a 1kHz corner frequency and operates with a 50kHz clock, a 49kHz, 1V_{RMS} input signal will cause an alias (1kHz, 0.7V_{RMS}) signal to appear at the output of the circuit; a 48kHz input will appear as a 2kHz output attenuated by 30dB.

The LTC1062 internal circuitry has a 4th order sampled data network so, in theory, it will be subject to the above aliasing phenomenon. In practice, however, the input (R, C) band limits the incoming, clock-approaching signals, and aliasing is nearly eliminated. Experimental work shows the following data:

f_{IN} , 0dB LEVEL	LTC1062 V_{OUT} AT ($f_{CLK} - f_{IN}$)	STANDARD 6th ORDER SWITCHED CAPACITOR LOWPASS FILTER V_{OUT} AT ($f_{CLK} - f_{IN}$)
$0.97 \cdot f_{CLK}$	-77dB	-22.0dB
$0.98 \cdot f_{CLK}$	-64dB	-3.5dB
$0.99 \cdot f_{CLK}$	-43dB	0dB
$0.995 \cdot f_{CLK}$	-45dB	0dB
$0.999 \cdot f_{CLK}$	-60dB	0dB

Cascading the LTC1062

Two LTC1062s can be cascaded with or without intermediate buffers. Figure 12 shows a DC accurate 10th order lowpass filter where the second LTC1062 input is taken directly from the DC accurate output of the first one. Because loading the junction of the input (R, C) causes passband error, the second resistor, R' should be much larger than R. The recommended ratio of (R'/R) is about 117/1; beyond this, the passband error improvement is not worth the large value of R'. Also, under this condition $(1/2\pi RC) = f_C/1.57$ and $(1/2\pi R'C') = f_C/1.6$. For instance, a 10th order filter was designed with a cutoff frequency, f_C , of 4.16kHz, $f_{CLK} = 416$ kHz and $R = 909\Omega$, $R' = 107$ k, $C = 0.066\mu F$ and $C' = 574$ pF. The maximum passband error was -0.6dB occurring around $0.5 \cdot f_C$. Figure 13 repeats the circuit of the previous figure but the second LTC1062 is fed from the buffered output of the first one. The filter's offset is the offset of the first LTC1062 buffer (which is typically under ± 5 mV and guaranteed 20mV over the full temperature range of the device). By using

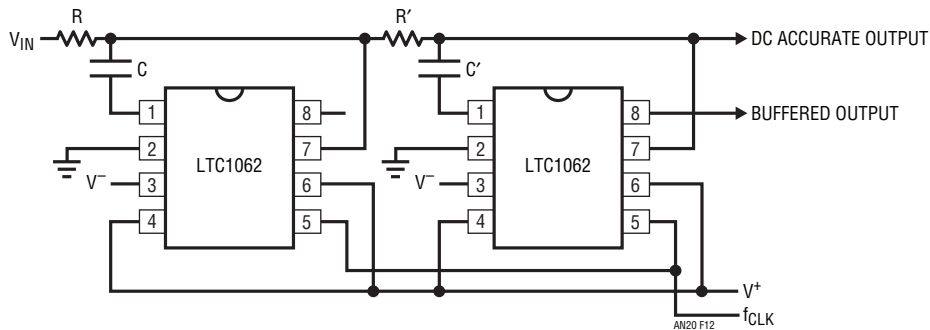

Figure 12. Cascading Two LTC1062s

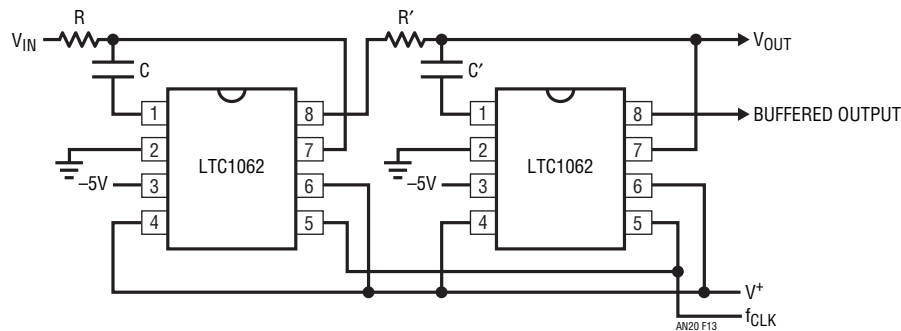

Figure 13. Cascading Two LTC1062s. The 2nd Stage is Driven by the Buffered Output of the First Stage

Application Note 20

this intermediate buffer, impedance scaling is no longer required and the values of R and R' can be similar. With this approach the passband gain error is reduced to -0.2dB. The recommended equation of the two (R, C) s are the following: $(1/2\pi RC) = f_C/1.59$ and $(1/2\pi R'C') = f_C/1.64$ or vice versa.

A 4kHz lowpass filter was tested with the circuit of Figure 13. The measured component values were $R = 97.6k$ and $C = 676pF$, $R' = 124k$ and $C' = 508pF$. The wideband noise

of the filter was $140\mu V_{RMS}$ and the worst-case second harmonic distortion occurred with $f_{IN} = 0.5 \cdot f_C$ as shown in Figure 14. With $1V_{RMS}$ input levels, the signal-to-noise ratio is 77dB and the worst-case dynamic range is 73dB.

Figure 15 illustrates a 12th order filter using two LTC1062s and a precision dual op amp. The first op amp is used as a precision buffer and the second op amp is used as a simple 2nd order noninverting lowpass filter to provide the remaining two poles and to eliminate any clock noise.

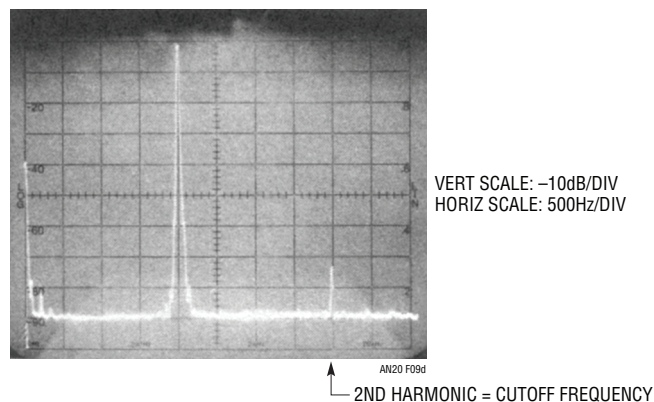

Figure 14. Response of the Filter of Figure 13 to a 2kHz 1V_{RMS} Input Sinewave. The 2nd Harmonic (Worst Case) Occurs at the Filter's Cutoff Frequency

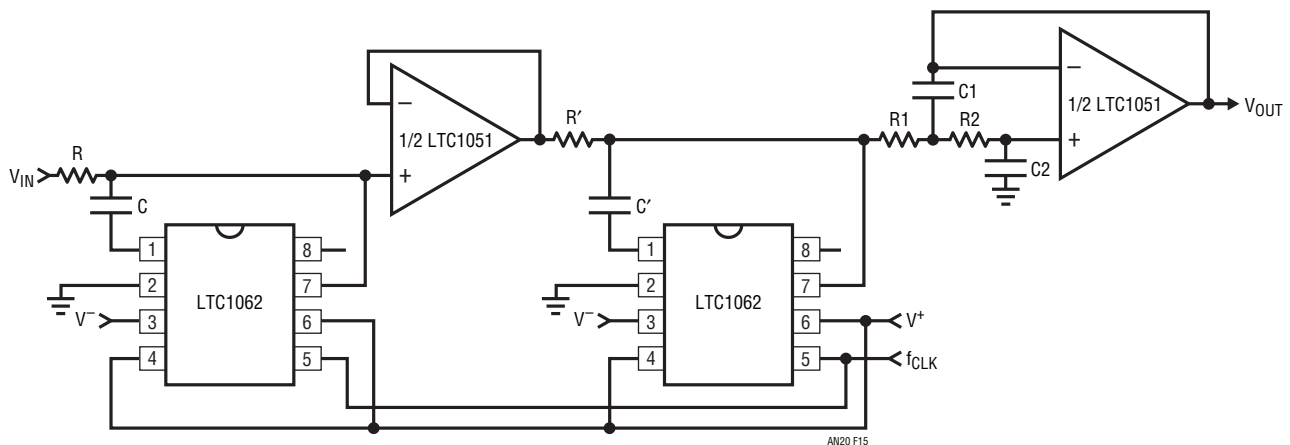

Figure 15. A Very Low Offset, 12th Order, Max Flat Lowpass Filter
 $R = 59k$, $C = 0.001\mu F$, $R1 = 5.7k$, $C1 = 0.01\mu F$
 $R1 = R2 = 39.8k$, $C1 = 2000pF$, $C2 = 500pF$, $f_{CLK} = 438kHz$, $f_C = 4kHz$

The output filter is tuned at the cutoff frequency of the LTC1062s and has a $Q = 1$ to improve the passband error around the cutoff frequency. For gain and Q equal to unity, the design equation for the center frequency, f_0 , is simple: let $C1/4C2$ and $R1 = R2$, then $f_0 = 1/(\pi R1 C1)$. The filter's overall frequency response is shown in Figure 16 with a 438kHz clock. The measured DC output offset of the filter was $100\mu\text{V}$, although the maximum guaranteed offset of each op amp over temperature would be $400\mu\text{V}$. Because the active (R, C) output filter is driven directly from the DC accurate output of the second LTC1062, impedance scaling is used with the resistor R' . The noise and distortion performance of this circuit is very similar to the one described for Figure 13.

Using the LTC1062 to Create a Notch

Filters with notches are generally difficult to design and they require tuning. Universal switched-capacitor filters can make very precise notches, but their useful bandwidth

should be limited well below half the clock frequency; otherwise, aliasing will severely limit the filter's dynamic range.

The LTC1062 can be used to create a notch because the frequency where it exhibits -180° phase shift is inside its passband as shown in Figure 17. It is repeatable and predictable from part to part. An input signal can be summed with the output of the LTC1062 to form a notch as shown in Figure 18. The 180° phase shift of the LTC1062 occurs at $f_{\text{CLK}}/118.3$ or 0.85 times the lowpass cutoff frequency. For instance, to obtain a 60Hz notch, the clock frequency should be 7.098kHz and the input $1/(2\pi RC)$ should be approximately $70.98\text{Hz}/1.63$. The optional ($R2C2$) at the output of the LTC1062 filters the clock feedthrough. The $1/(2\pi R2C2)$ should be 12 to 15 times the notch frequency. *The major advantage of this notch is its wide bandwidth. The input frequency range is not limited by the clock frequency because the LTC1062 by itself does not alias.*

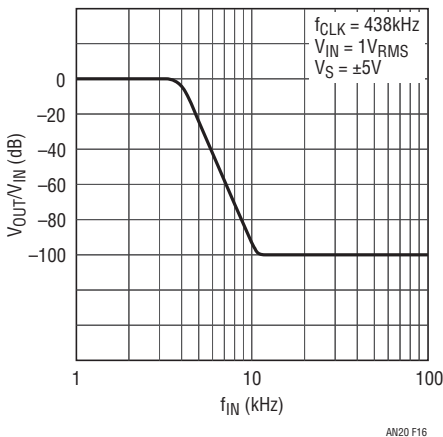

Figure 16. Frequency Response of the 12th Order Filter of Figure 15

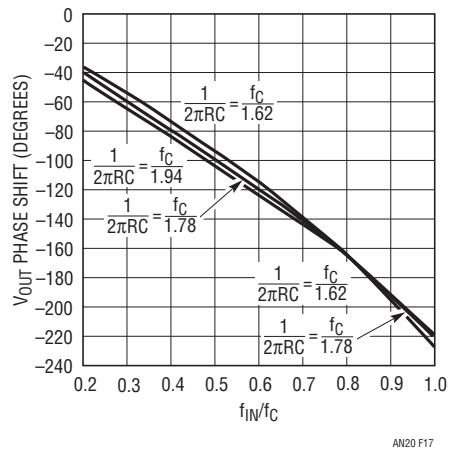

Figure 17. Phase Response of the LTC1062 for Various Input (R, C)s

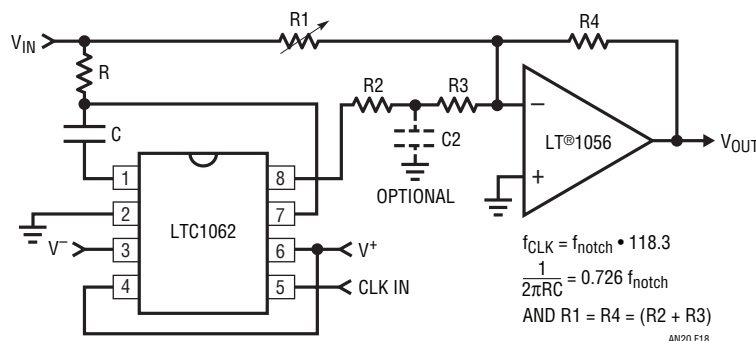

Figure 18. Using the LTC1062 to Create a Notch

Application Note 20

The frequency response of the notch circuit is shown in Figure 19 for a 25Hz notch. From part to part, the notch depth varies from 32dB to 50dB but it can be optimized by tuning resistor R1. Figure 20 shows an example of the wideband operation of the circuit. These pictures were taken with the filter operating with a 3kHz clock frequency and forming a 25Hz notch. Figure 20a shows the circuit's response to an input 1kHz, 1V_{RMS} sinewave; Figure 20b shows the response to a 10kHz, 1V_{RMS} sinewave. The high frequency distortion of the filter will depend on the quality

of the external op amp and not on the filter. The measured wideband noise from DC to 20kHz was 138V_{RMS} and the measured noise from 50Hz to 20kHz was 30μV_{RMS}.

The circuit of Figure 21 is an extension of the previous notch filter. The input signal is summed with the lowpass filter output through A1, as previously described; then, the output of A1 is again summed with the input voltage through A2.

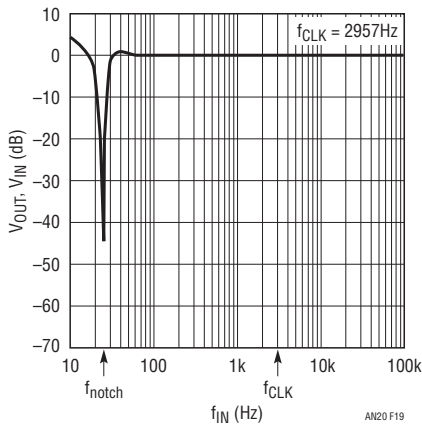
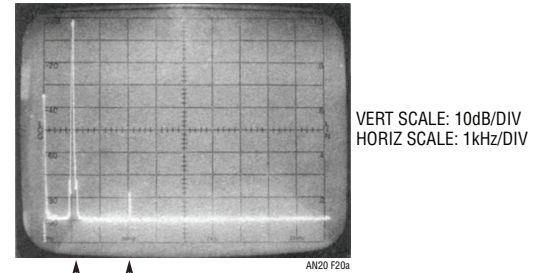
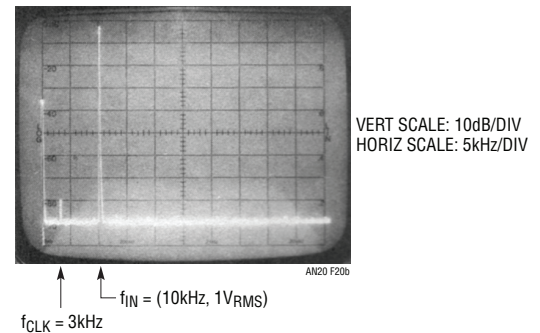

Figure 19



(20a) Response of a 25Hz Notch Filter to a 1kHz, 1V_{RMS} Input Sinewave



(20b) Same as Above but the Input is a 10kHz Sinewave

Figure 20

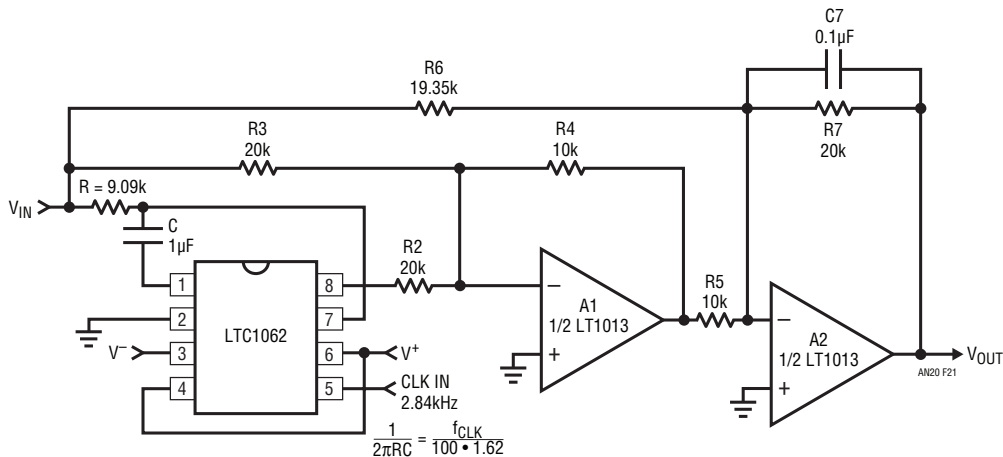

Figure 21. A Lowpass Filter with a 60Hz Notch

If $R6 = R2 = R3 = R7$ and $R4 = R5 = 0.5R7$, the output of A2 at least theoretically, should look like the output of LTC1062 Pin 8. If the ratio of $(R6/R5)$ is slightly less than 2, a notch is introduced in the stopband of the LTC1062 as shown in Figure 22. The overall filter response looks pseudoelliptic lowpass. The frequency of the notch is at $f_{CLK}/47.3$ and the value of the resistor ratio $(R6/R5)$ should be equal to 1.935.

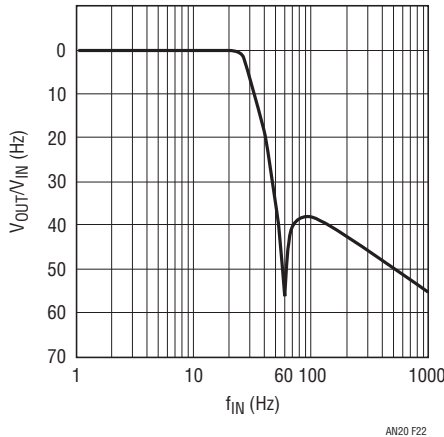

Figure 22. Amplitude Response of the Filter, Figure 21

Comments on Capacitor Types

Experimental work, done in a laboratory environment, shows that the passband gain error is the same when mylar, polystyrene and polypropylene capacitors are used. All the experiments done for this application note used mylar capacitors for $0.001\mu\text{F}$ and up and silver mica for less than 1000pF .

Solid tantalum capacitors connected back to back, as shown in Figure 23, introduce an additional passband error of 0.05dB to 0.1dB . For cutoff frequencies well below 10Hz and for limited temperature range, the back to back solid tantalum capacitor approach offers an economical and board saving solution provided that their leakage and tolerances are acceptable. When disc ceramic capacitors were used as part of the required input (R, C) of the LTC1062, the passband accuracy of the filter was similar to that obtained with solid tantalum capacitors. Ceramic capacitors should be avoided primarily because of their large and unpredictable temperature coefficient. NPO ceramic capacitors, however, are highly recommended especially for military temperature range. Their maximum available value is of the order of $0.1\mu\text{F}$, their physical size is reasonable and they are available with $\pm 20\text{ppm}/^\circ\text{C}$ tempco.

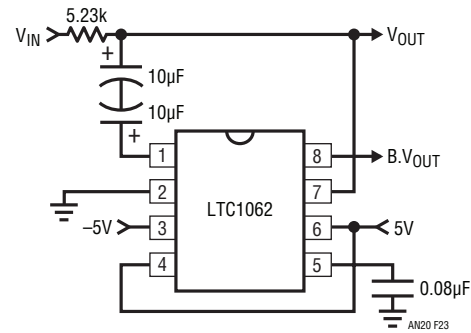

Figure 23. A Low Frequency, 5Hz Filter Using Back to Back Solid Tantalum Capacitors

Clock Circuits

Application Note 12 describes in detail various clock generation techniques which can be applied for the LTC1062 requirements. Two basic circuits are repeated and explained below:

1. Low frequency oscillators: A simple (R, C) oscillator is shown in Figure 24. It uses a medium speed comparator with hysteresis and a feedback $(R1, C1)$ as timing elements. The capacitor, $C1$, charges and discharges to $2V^+/3$ and $V^+/3$ respectively. Because of this, the frequency of oscillation is, at least theoretically, independent from the power supply voltage. If the comparator swings to the supply rails, if the pull-up resistor is much smaller than the resistors R_h and if the propagation delay is negligible compared to the RC time constant, the oscillation frequency is:

$$f_{osc} = \frac{0.72}{R1C1}$$

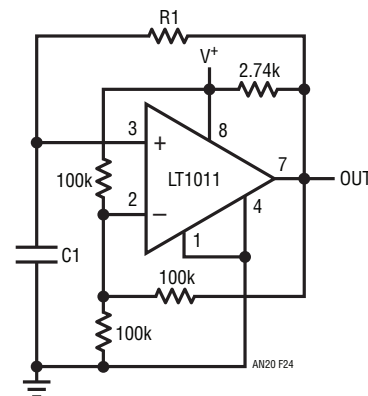

Figure 24. A Low Frequency, Precision (R, C) Oscillator. For Bipolar $\pm 5\text{V}$ Output Swing Refer the Ground Connection to -5V

Application Note 20

For LT111 or LT1011 type comparators, this holds for $f_{OSC} \leq 3\text{kHz}$. The circuit of Figure 24 is adequate to drive an LTC1062 tuned in the vicinity of 10Hz to 30Hz cutoff frequency. Also, when the input (R, C) of the LTC1062 and the (R1, C1) of the comparator have the same temperature coefficient, the cutoff frequency will drift but the passband error will be temperature independent since:

$$\frac{1}{2\pi RC} \cong \frac{f_c}{1.63} = \frac{0.72}{163 \cdot R1C1} \text{ or } (R1C1/RC) = 1/36$$

For $C = 10C1$, then $R = 3.6R1$, which yields a reasonable resistor and capacitor value spread.

- The RC oscillator of Figure 24 can also be used up to 110kHz but the frequency of oscillation is about equal to $0.66/R1C1$ and the duty cycle 60%. Again the major frequency drift component will be due to the drift of the $R1C1$. If the cutoff frequency of the filter should be made as temperature independent as possible, the $(R \cdot C)$ and $(R1 \cdot C1)$ products should also be made temperature independent. This can be achieved by choosing resistors and capacitors of nearly opposite temperature coefficients. For instance, TRW MTR-5/+ 120ppm/°C resistors can be used with -120ppm/°C $\pm 30\text{ppm}$ WESCO type 32-P capacitors.

- Crystal oscillators: Figure 25 shows an LT1011 comparator biased in its linear mode and using a crystal to establish its resonant frequency. With this circuit we can achieve a few hundred kHz, temperature independent clock frequency with nearly 50% duty cycle. Many systems already have a crystal oscillator using digital

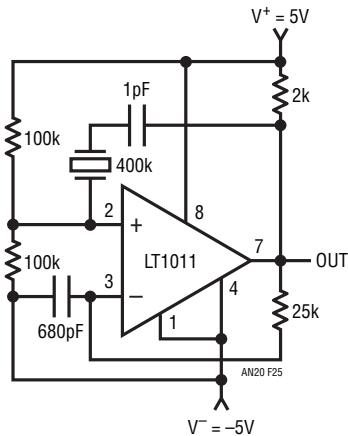

Figure 25. Crystal Oscillator with 50% Duty Cycle

gates as active elements, Figure 26. Their frequency, however, is usually above 1MHz and should be divided down before being applied to the LTC1062. Figure 27 shows an inexpensive discrete crystal oscillator using a single transistor as gain element. Its output can directly drive Pin 5 of the LTC1062 and its Pin 4, should they be converted to analog ground or negative supply to activate the internal divide by 2 or 4 of the circuit. This is necessary because the duty cycle at the collector of the crystal oscillator is not 50%.

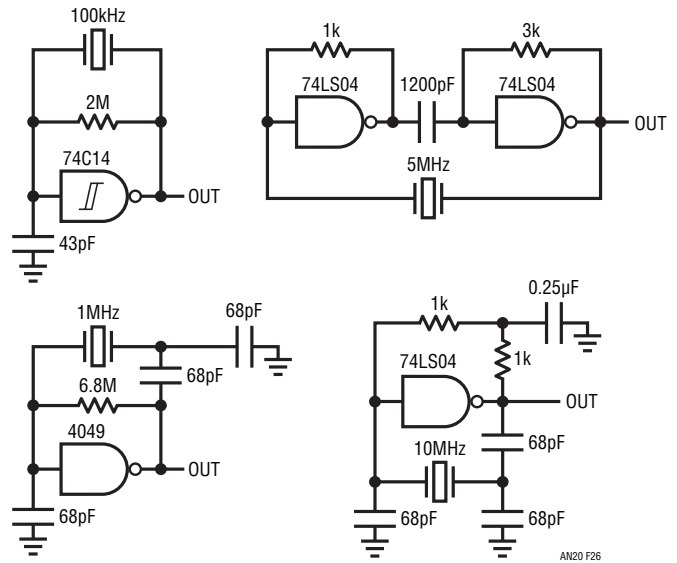

Figure 26. Typical Gate Oscillators

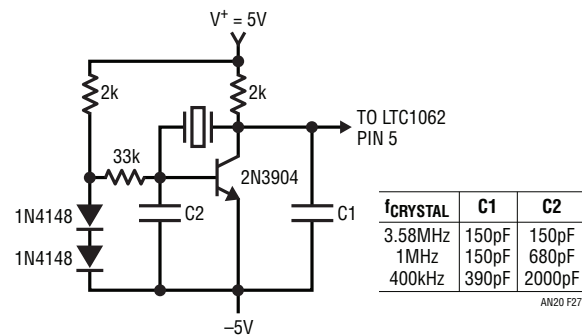

Figure 27. Discrete, Low Cost Oscillator Using Parallel Type AT-CUT Crystal

Acknowledgement

For this application note, the laboratory work was done by Guy Hoover whose meticulousness and contributions are greatly appreciated.