

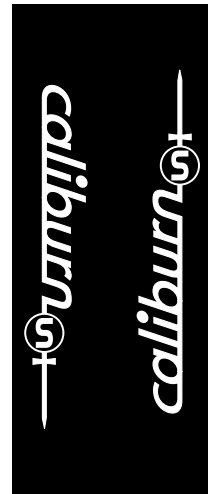

caliburn 
OWNERS MANUAL

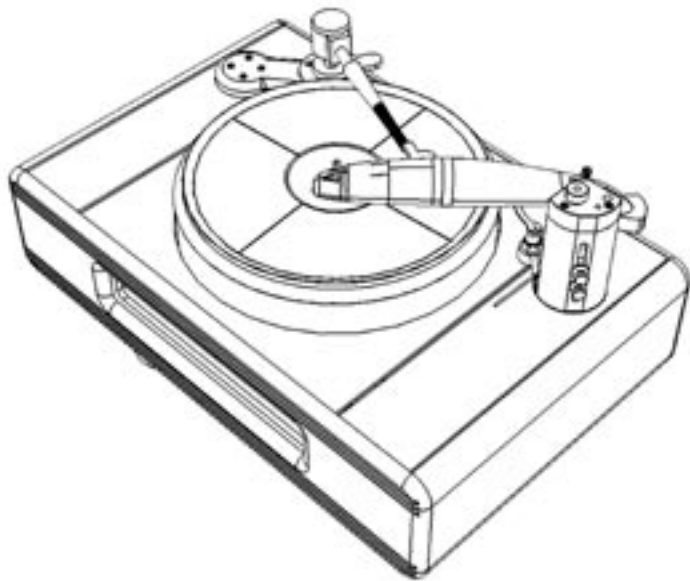



Welcome and congratulations on your purchase of our Caliburn turntable. Your Caliburn was hand-crafted and assembled by the team at Continuum Audio, and has been rigorously tested and is ready for your enjoyment.

We ask that you take the time to read this manual carefully to ensure that you not only enjoy optimum sound quality from your Caliburn, but also understand the care and maintenance procedures required to keep your Caliburn in as-new condition for many years to come.

If you have any questions in reference to any part of your Caliburn at any time in the future, please feel free to contact your Continuum Consultant for assistance.

Your Authorised Continuum Consultant is:

Serial Number:

Date of Manufacture:

WARNING

To prevent fire or shock hazard, do not expose this unit to rain or moisture.

To avoid electrical shock, do not open the cabinet. Refer servicing to qualified personnel only.

Precautions

On Safety

Should any solid object or liquid fall into the cabinet, unplug the unit and have it checked by your Factory Authorized Consultant

On Power Sources

- Before operating the unit, check that the operating voltage is identical with your local power supply. The operating voltage is indicated on the name plate at the rear of the unit.
- The unit is not disconnected from the AC power source (mains) as long as it is connected to the wall outlet, even if the unit itself has been turned off.
- If you are not going to use the unit for a long time, be sure to disconnect the unit from the wall outlet. To disconnect the AC power cord, grasp the plug itself;

never the cord.

- AC power cord must be changed only at a qualified service shop.

On Placement

- Place the unit in a location with adequate ventilation to prevent heat buildup and prolong the life of the unit.
- Do not place the unit near heat sources, or in a place subject to direct sunlight, excessive dust or mechanical shock.
- Do not place anything near the unit that might block ventilation and cause malfunction.

On Operation

Before connecting to other components, be sure to turn off and unplug the unit.

On Cleaning

Clean cabinet, panels and controls with a soft cloth slightly moistened with a mild detergent solution. Do not use any type of abrasive pad, scouring powder or solvent such as alcohol or benzine.

If you have any questions or problems concerning your Caliburn turntable, please contact your Authorized Installation Consultant.

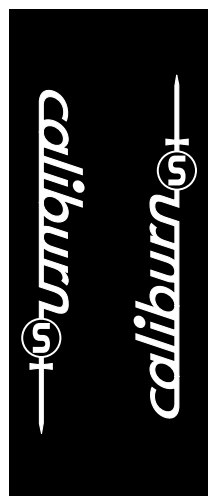

TABLE OF CONTENTS

TABLE OF CONTENTS

OUR DESIGN PHILOSOPHY	6
CALIBURN'S COMPONENTS	8
INSTALLATION	
Your Caliburn will be fully installed by your Authorised Continuum Consultant.....	10
OPERATING INSTRUCTIONS	
Turntable record playing procedure	12
Vacuum Selection	14
Turntable stopping procedure	16
Speed Selection	18
Manual Turntable Speed Adjustment procedure	20
Factory Speed Calibration value restore procedure.	24
OWNER CARE & MAINTENANCE	
Cleaning Routine	28
Scheduled Factory Service	32
Faults & Trouble shooting.....	34
THE CALIBURN'S DESIGN HISTORY	
A brief history of how the Caliburn came to be.....	42

**DO NOT ATTEMPT
TO LIFT THIS
UNIT WITHOUT
CONTACTING
YOUR CONTINUUM
CONSULTANT FIRST.**

**DAMAGE RESULTING
FROM MOVING THIS
UNIT MAY VOID
YOUR WARRANTY**

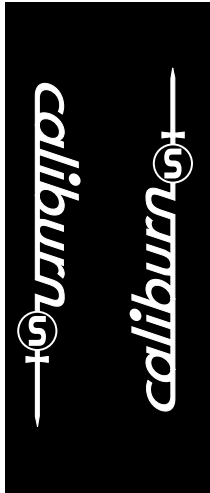

AIM FOR PERFECTION



Perfection, as a design concept, is not easily defined. It maybe easier explained by listing the rules it cannot be constrained by - budget, time, materials, tradition, aesthetics, fashion or dogma.

AIM FOR PERFECTION, means we strive remove all the constraints listed above, allowing us to concentrate wholly on creating a product whose only constraint is perfection itself. How close we get is for others to judge, but we see no point aiming for anything less.

The Caliburn is the direct result of this design philosophy, and was created because, after looking closely at the state-of-the-art, we believed it could be better.

Any future products from Continuum Audio Labs will follow this same philosophy - if we believe it can be better, we will build it. If we believe we cannot improve it, we will enjoy and happily recommend the state-of-the-art product. Because, our ultimate aim is the pursuit of perfect sound reproduction.

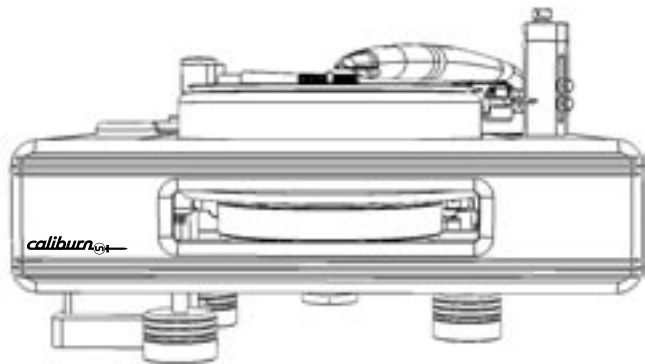

CALIBURN TURNTABLE

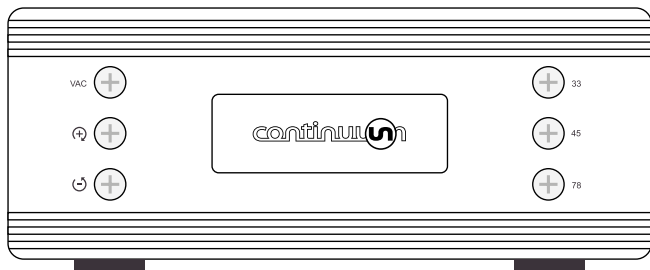

CALIBURN CONTROL UNIT

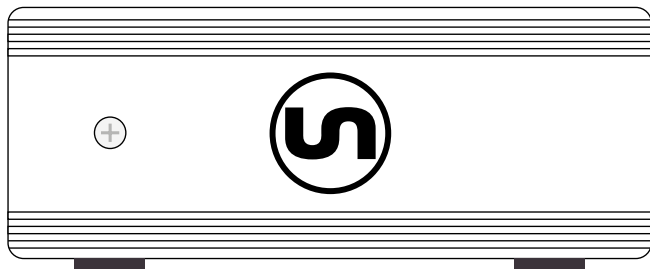

CALIBURN VACUUM UNIT

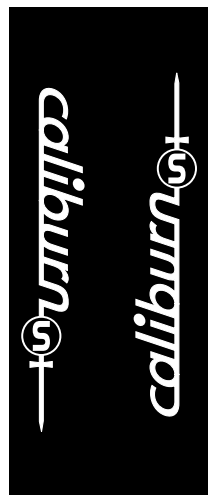

CALIBURN COMPONENTS

PARTS OF
YOUR
CALIBURN

The Caliburn consists of three separate units that combine to create a most sophisticated analogue playback system.

THE CALIBURN TURNTABLE

The Caliburn turntable is a precisely engineered piece of equipment designed to be a silent foundation for the record to sit, allowing the stylus to extract the maximum information from the record's groove.

THE CALIBURN CONTROL UNIT

The Caliburn Control Unit controls start process for platter via the speed selection, 33, 45 and 78, and speed adjustment/memory settings and the vacuum.

THE CALIBURN VACUUM UNIT

The Caliburn Vacuum Unit is a super quiet pump mechanism with a "stealth-mode" operation during playback. It is computer controlled with a negative pressure mechanism to maintain minimum vacuum for record playback. It has an "on" button, but for ease of use, we recommend using the "vac" button on the Control Unit to start the vacuum.

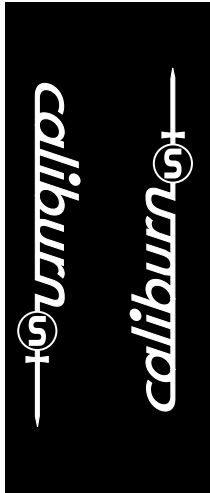

INSTALLATION

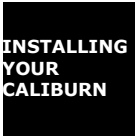

Your Caliburn is a complex piece of audio equipment requiring an understanding of hydraulics, vacuum settings, electronics, vibration and materials engineering in order to assemble it, which is why we have organized for our specifically trained Authorized Installation Consultant to install your Caliburn.

Please do not lift this unit.

If in the future you need to move your Caliburn to a new location, we ask that you contact your consultant to ensure that your Caliburn isn't damaged during transportation and that it is set-up correctly in the new location so as to fully optimize the performance of your Caliburn turntable.

Please store the road-case that your Caliburn came in so that any future transportation your Caliburn may need to take, can be done safely. Talk to your consultant if you would like us to store this road-case for you.

If you have any questions in reference to any part of your Caliburn at any time in the future, please feel free to contact us or your Consultant for assistance.

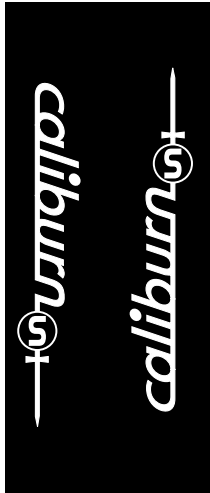

OPERATING INSTRUCTIONS

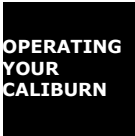

Now that your Caliburn turntable has been installed and fully optimized it is now ready for you to enjoy. Please take a moment to familiarize yourself with the basic controls for operating your Caliburn.

RECORD PLAYING PROCEDURE

Note: Clean equipment and clean media is a necessary prerequisite to ensure the Caliburn will give you the best performance every time.

Ensure that the platter surface on the turntable is clean and dust free, and clean the record to be played on both sides, using electrostatic dust pad to remove any dust.

Place the record on the platter, ensuring the black outer sealing rubber ring is evenly placed around the rim of the record so as to create optimum negative pressure when the vacuum is turned on.

Set the master amplifier volume control close to its minimum setting to avoid damaging your speakers.

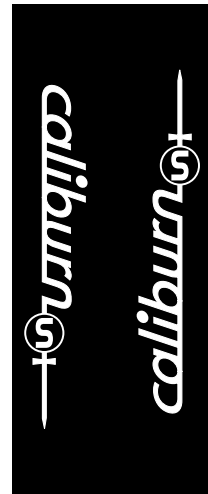
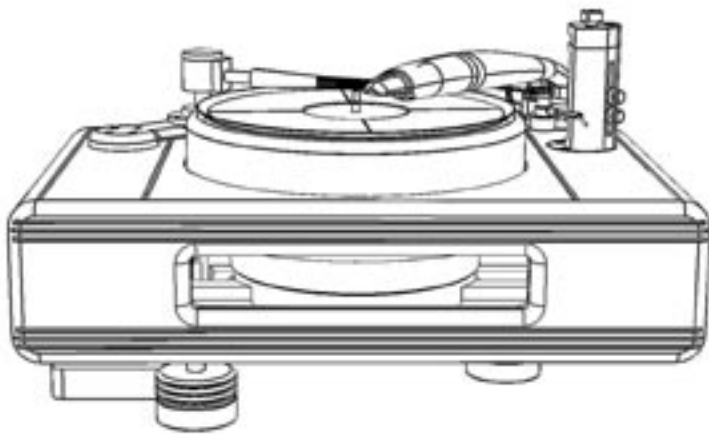

OPERATING INSTRUCTIONS CONT.

OPERATING
YOUR
CALIBURN

OPERATING THE VACUUM

Press the Vacuum button on the Caliburn Control Unit to the " ON " position. The LED will light up. The record is drawn down to the platter within a few seconds. Use the supplied vacuum spindle seal to secure the record to the spindle.

Next, select the required play speed by pressing the corresponding button on the Control Unit - 33, 45 or 78. The LED will light up. The motor will start and the platter will start to spin at the selected speed.

Wait about ten seconds for the platter speed to stabilise, then place the stylus arm gently on the record and enjoy.

Note: If an electrical protection device (Fuse) blows, your Authorised Continuum Consultant should be called to investigate the reason for the failure.

OPERATING INSTRUCTIONS *CONT.*

OPERATING
YOUR
CALIBURN

REMOVING RECORD PROCEDURE

Set the master amplifier volume control close to its minimum setting to avoid any damaging your speakers.

Gently remove the stylus arm from the record and place it on its rest position.

Press the selected speed button (LED will be on) on the Control Unit to stop the motor and platter from spinning (LED will turn off).

Press the Vacuum button on the Control Unit to turn the vacuum off (LED will turn off). The record slowly rises up away from the platter within a few seconds.

Wait about ten seconds, then remove clamp and spindle seal. The record can now be removed from the platter.

If you have finished playing records, place a cover over your Caliburn, to protect the platter, tonearm and stylus from dust and to keep your Caliburn in pristine condition.

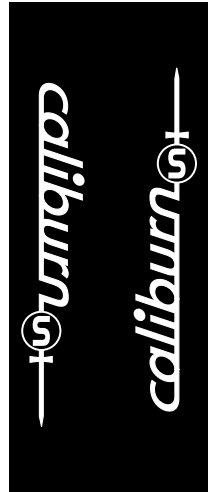

OPERATING INSTRUCTIONS CONT.

OPERATING
YOUR
CALIBURN

OPERATING THE MANUAL SPEED SELECTION

The Caliburn turntable has one of the most advanced speed control systems that today's technology can provide. The turntable is fitted with a drive motor fully integrated with electronic control to maintain the speed to preset values within a Micro controller. There are two possible ways to set the turntable playing speeds:



i) **MANUAL** adjustment via "SPEED LOWER & SPEED RAISE" push buttons  .

ii) **FACTORY PRESET** value - permanently set within the controller during Factory calibration.

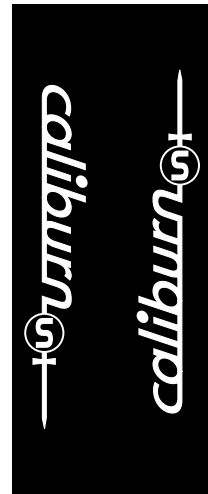
Place a speed calibration strobe disk (*available from quality hi-fi suppliers*) on the platter, following the previously mentioned record playing procedure, and press the platter speed button of the desired speed to be adjusted i.e. 33, 45 or 78.



OPERATING INSTRUCTIONS *CONT.***OPERATING
YOUR
CALIBURN****MANUAL SPEED SELECTION** *CONT.*

Simultaneously press "Speed Lower" and "Speed Raise" push buttons   on the Control Unit and hold down for more than 5 seconds. A small "click" sound means the Speed Control Computer is in adjustment mode.

Release the push buttons " both LED lights should come on the push buttons. If "ON steady" they indicate that the speed is the same as the calibrated value.

To lower the speed of the Platter, push the "Speed Lower" button . This will cause the platter speed to reduce by 0.1 r.p.m. each time it is pressed. The light on the push-button will start to flash once the speed of the platter is less than 0.1 r.p.m. than the previous calibration value.

Once you have set the desired speed, you must wait 45 seconds, with no further adjustments for the Caliburn Control Unit to accept and store the setting into its memory as the new user default. Should you wish to make further speed changes, repeat this procedure.

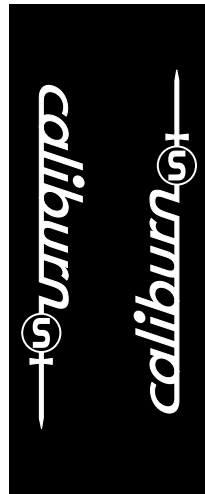

OPERATING INSTRUCTIONS *CONT.*

OPERATING
YOUR
CALIBURN

MANUAL SPEED SELECTION *CONT.*

To Raise the speed of the platter push the "Speed Raise" push button (+) on the Control Unit. This will cause the platter speed to increase by 0.1 r.p.m. each time it is pressed.

The light on the push-button will start to flash once the speed of the platter is greater than 0.1 r.p.m. than the previous calibration value.

Once you have set the desired speed, you must wait 45 seconds, with no further adjustments for the Caliburn Control Unit to accept and store the setting into its memory as the new user default. Should you wish to make further speed changes, repeat this procedure.

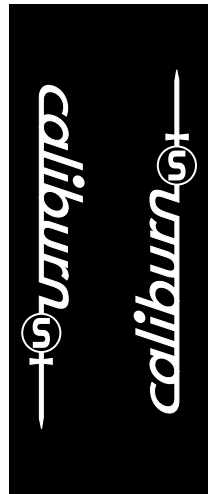



OPERATING INSTRUCTIONS CONT.

OPERATING
YOUR
CALIBURN

MANUAL SPEED SELECTION CONT.



RESTORE FACTORY DEFAULT SPEED SELECTION

On the Control Unit, press the SPEED selector button to OFF (LED will turn off), and then press the VACUUM button to OFF (LED will turn off).

Press simultaneously the "Speed Lower" and "Speed Raise" push button   on the Control Unit and hold for 15 seconds.

The controller is now in FACTORY DEFAULT RESTORE MODE. The original factory calibration settings are restored.

To restore the "33 rpm speed factory default value"

Press the 33 rpm Speed selector button (LED will light up). Press simultaneously "Speed Lower" and "Speed Raise" buttons   on the Control Unit, hold for more than 15 seconds.

The 33 rpm speed setting is now reset.

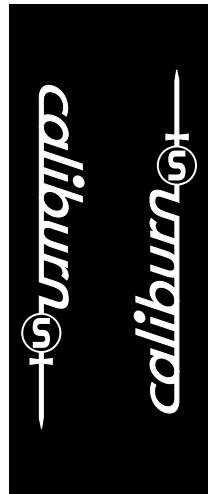

OPERATING INSTRUCTIONS *CONT.*

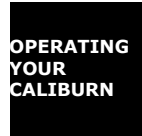

MANUAL SPEED SELECTION *CONT.*

RESTORE FACTORY DEFAULT SPEED SELECTION *CONT.*

To restore the "45 rpm speed factory default value"

Press the 45 rpm Speed selector button (LED will light up). Press simultaneously "Speed Lower" and "Speed Raise" buttons (+) (-) on the Control Unit, hold for more than 15 seconds.

The 45 rpm speed setting is now reset.

To restore the "78 rpm speed factory default value"

Press the 78 rpm Speed selector button (LED will light up). Press simultaneously "Speed Lower" and "Speed Raise" buttons (+) (-) on the Control Unit, hold for more than 15 seconds.

The 78 rpm speed setting is now reset.

Press speed selector buttons to the OFF position (LED's will turn off), wait 2 minutes, the unit is now ready to use with the original settings.

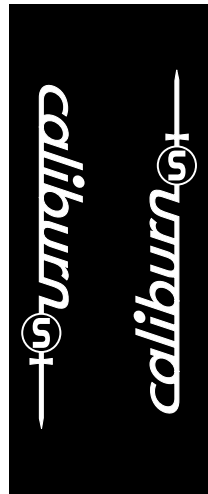

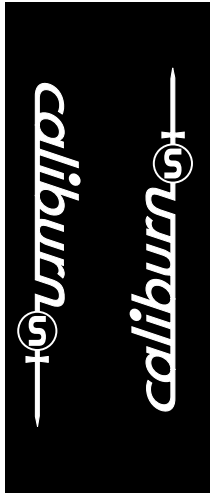

OWNER CARE & MAINTENANCE



Your Caliburn turntable is a delicate piece of equipment, and care needs to be taken when using and cleaning it. Below are recommendations for keeping your Caliburn at its optimum performance.

CARING FOR METAL SURFACES

The metals we have chosen because of their superior sound qualities are more susceptible than other common alloys, to being dented and scratched. Care should be taken when using your Caliburn. Make sure there are no sharp objects on or near that could scratch the metal surfaces. Clean with a soft camera-lens-quality cleaning chamois. **Do not use any window cleaning solutions, silicon based polish, abrasive pads, scouring powder or solvents such as alcohol or bezzine to clean your Caliburn. Your Continuum Consultant can advise you on what products available in your area are suitable to use for cleaning.**

CLEANING THE PLATTER

The platter can be cleaned using a soft, camera-lens-quality, cleaning chamois.

OWNER CARE & MAINTENANCE

CARING
FOR YOUR
CALIBURN

BEARING MAINTENANCE

The bearing is fully enclosed and requires no owner maintenance. Bearing oil is a proprietary formulation and is replaced during the scheduled factory service (*recommended every 3 years*). If you hear any unfamiliar noise coming from your Caliburn, turn the unit off immediately and contact your Continuum Consultant.

NOTE: Use of any oil other than our proprietary formulation will void your warranty.

MOTOR

The motor is sealed and can only be serviced by an Authorised Continuum Agent. Warranty will be void if seal is broken.

MOTOR BELT REPLACEMENT

Replacement of the belt requires the removal of the tonearm assembly. We recommend you contact your Continuum Consultant. The belt is replaced during the scheduled factory service (*recommended every 3 years*). Three belts are supplied with your Caliburn.

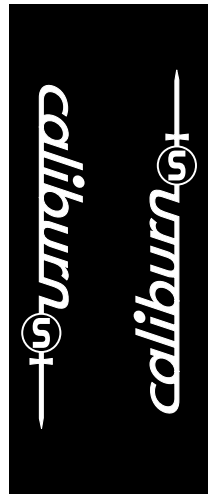

SCHEDULED FACTORY SERVICE

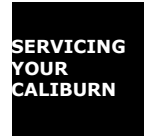

Your Caliburn has been built with the highest quality materials and components to exacting specifications. Like anything with moving parts, that relies on precision machining to work at their optimum, your Caliburn will need to be serviced from time to time.

We recommend that you have your Caliburn serviced every three years to ensure that your Caliburn remains in top condition and runs at it's optimum performance.

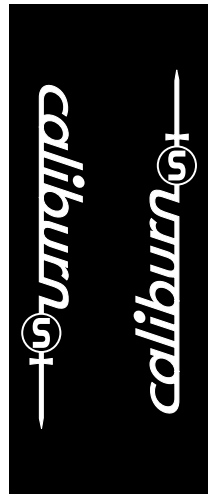

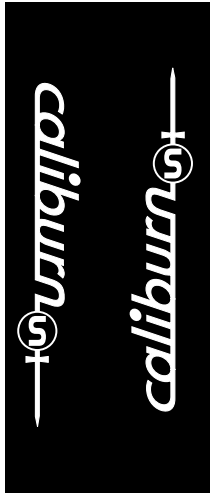

FAULTS & TROUBLE SHOOTING

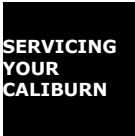

Whenever a fault or failure is detected, the computer in the Control Unit will flash the output "Q1" lamp at different pulse rate, to indicate the different faults, these are listed in the table below.

To reset Alarms just operate the "Speed Lower" & "Speed Raise" push buttons   for 2 seconds.

To reset the Service Alarms, hold the push-button pressed for at least 20 seconds

FAULT CODE	FAULT FUNCTION DESCRIPTION	RESET ALARM
1 pulse	33 r.p.m. CALIBRATION VR1 Adjustment mode ON	Not applicable
2 pulses	45 r.p.m. CALIBRATION VR2 Adjustment mode ON	Not applicable
3 pulses	78 r.p.m. CALIBRATION VR1 Adjustment mode ON	Not applicable
4 pulses	33 r.p.m. Push button Adjustment mode ON	Not applicable
5 pulses	45 r.p.m. Push button Adjustment mode ON	Not applicable
6 pulses	78 r.p.m. Push button Adjustment mode ON	Not applicable

FAULTS & TROUBLE SHOOTING

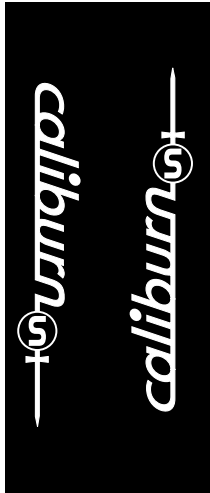

FAULT CODE	FAULT FUNCTION DESCRIPTION	RESET ALARM
7 pulses	POOR VACUUM ALARM - PUMP FAILED- Major Vacuum Leak present in System pipe work Vacuum Valves closed - Excessive vacuum usage	Hold "Speed Lower & Raise" P/B 2 sec
8 pulses	FEEDBACK SIGNAL FAILED - Call your Continuum Consultant.	Hold "Speed Lower & Raise" P/B 2 sec
9 pulses	VACUUM SENSOR FAULTY or Out of Adjustment. Call your Continuum Consultant.	Hold "Speed Lower & Raise" P/B 2 sec
10 pulses	ORIGINAL FACTORY SETTING MODE ON -	Hold "Speed Lower & Raise" P/B 2 sec
11 pulses	VACUUM PUMP SERVICE DUE: 5,000 Hours RUN Call your Continuum Consultant.	Hold "Speed Lower & Raise" P/B 30 sec
12 pulses	TURNTABLE MOTOR SERVICE DUE: 5,000 Hours RUN Call your Continuum Consultant.	Hold "Speed Lower & Raise" P/B 30 sec

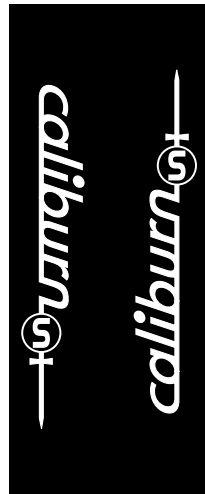

SPECIFICATIONS

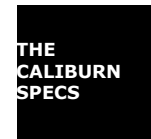

CALIBURN TURNTABLE

- 86 kilo fully assembled

PLATTER

- 36 kilo nested platter mass.
- 1-4 kilos pressure exerted on the bearing

BEARING

- Solid one-piece, centre ground steel alloy with high tin compound bronze bearing with machined internal oil galleries and oil recirculation system.

VACUUM

- Super quiet pump mechanism with "stealth-mode" operation during playback.
- Computer controlled, negative pressure mechanism to maintain minimum vacuum for record playback.

MOTOR

- No cogging or hysteresis torque
- Cogging and hysteresis torque
(c and o h) 0 oz-in.
- Viscous drag torque (ac) 0.16 oz-in./krpm

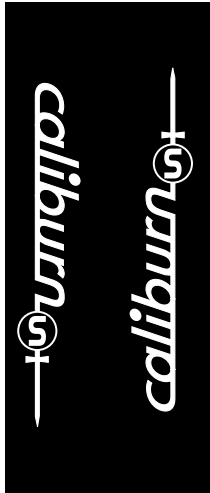

SPECIFICATIONS



MOTOR cont.

- Friction torque (fr) 1.8 oz-in.
- 600 oz-in. peak torque
- Bearing type – Silent Running Gimbal
- Rotor inertia (J) 0.030 oz-in.-sec²
- Flat torque output
- High power density 11.3 W/oz
- Continuous torque 120 oz-in. @ 2450 rpm
- High efficiency
- 12–48 VDC
- Smooth, controllable power
- Current – (I_{max}) 15.6 amps
- Motor constant (K_m) 0.11 Nm/sqrt (W)
15.58 oz-in./sqrt (W)
- Back EMF constant (K_v) 0.0602 vpk/rad./s
- Mechanical time constant (T_m) 18 mS
- Electrical time constant (T_e) 0.033 mS

THE CALIBURN IS THE FRUIT OF COLLABORATION

Many very intelligent minds were brought together to push the envelope of what was imagined possible for turntable technology, and we would like acknowledge each one of them now.

Mark Doehmann - Chief Designer

Marks' passion for analogue sound reproduction combined with his background in aeronautical and advanced software engineering and materials fabrication techniques was used to transform his vision from the "virtual world" to the end product that is the Caliburn and the Cobra.

David Payes - Chairman, Continuum Audio Labs

David was the catalyst for the development of the Caliburn, and created the financial and creative freedom to push the envelope. David is a passionate audiophile and has had extensive input with technical design issues.

Dr Murali Murugasu MB.ChB. MBA

Murali is part of the core design team at Continuum Audio Labs. His day to day involvement ensures that our products meet various regional market requirements and ensures that they works in harmony with other high quality components to deliver a complete solution.

CALIBURN'S DESIGN HISTORY

CALIBURN'S
DESIGN
HISTORY

Passion is a powerful force; shared passion is twice as powerful.

Mark Doehmann, Caliburn's Chief Designer, believed his passion for analogue sound was unmatched, until he met David Payes.

Mark Doehmann has been building custom turntables for a select clientele for over 20 years. These turntables aimed to solve the particular problems of each system, by trading off advantage against disadvantage in an attempt to create a balance Mark knew, to his frustration, was ultimately a compromised solution. Compromise he accepted as inevitable in his quest for the purest analogue sound possible.

David Payes is a well-respected Australian businessman and a passionate audiophile. During the installation of a highly regarded turntable onto David's system and the subsequent evaluation of the results, David asked Mark, if money was no object, what would he do to improve the turntable. Thinking in terms of this being a theoretical conversation, Mark nominated the platter as the first thing he would change. David response was "Ok, do it".

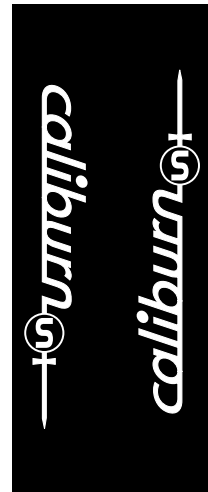

So began the first step in the long and challenging process of developing the Caliburn.

Mark's ultimate aim when imagining the perfect platter was to create a silent foundation for the record to sit, to allow the stylus to extract the maximum information from the record's groove.

Mark realized to create his vision would require some very sophisticated engineering. With his background in aeronautical engineering, Mark called upon the expertise of some of his colleagues from this field.

A unique alloy formula to address the stiffness and damping of the platter was developed with the help of materials engineer John Vietz. Using the most advanced shape optimization computer technology

Dr. Neil McLachlan developed the optimum shape for the first prototype of the Caliburn to reduce vibration to an absolute minimum.

After months of complex computer modelling, Mark returned to David Payes with the Caliburn's nested platter design and rather nervously replaced the existing platter and sat back with David to listen to the results.

CALIBURN'S DESIGN HISTORY

CALIBURN'S
DESIGN
HISTORY

It was obvious to both of them that there was a marked improvement in the sound they were hearing. The nested platter design matched the predicted computer modelling results, and was delivering real-world results.

David then asked, if this was possible with a re-design of the platter alone, what could be achieved if this same rigorous design process was applied to all the components of a turntable?

This same process of development was now applied to every aspect of a turntable. The chassis, the bearing, the motor were all designed with a back-to-the-drawing-board approach.

The tonearm - the Cobra came out of left field, the shape optimization software developing a shape and choice of material, that at the time, was to say the least, surprising, but when looked at now it seems oh so logical. The Cobra delivers what tonearm technology has been trying to achieve for years - significantly more damping and stiffness with reduced mass and weight.

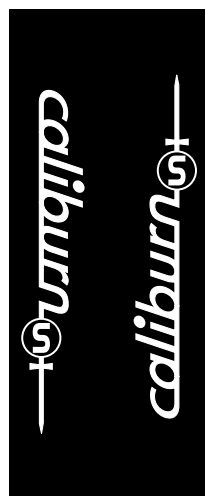

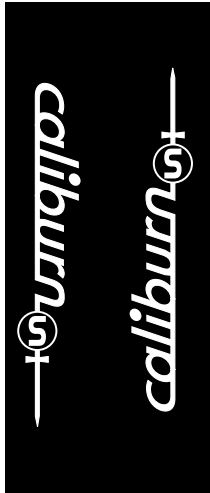

CALIBURN'S DESIGN TEAM



John Loton - Bachelor of Engineering (Aeronautical) Advanced Physics & Structures Design. - John was instrumental in the "challenging process" where original "seed ideas" were subjected to an intense peer review process to eliminate potential "blind alleys"

John Vietz - Bachelor of Engineering (Metallurgical) - Honours Melbourne Uni '61 - A recognized leader in his field, John developed Caliburn's unique magnesium alloy which gives Caliburn it's high damping characteristics.

Dr. Neil McLachlan - Professor at RMIT University's School of Architecture & Design. - Neil worked closely with Mark on the reshaping and acoustic modelling and design, and developed new and innovative solutions to the some very old problems associated with analogue sound reproduction.

Michail Barabasz - Bachelor of Engineering (Electrical), Advanced Magnetic Bearing Design. - An expert in magnetic circuit design and voice coil engineering, Michail developed the unique magnetic propulsion system to levitate and drive the platter.

Joe Persico - Bachelor of Engineering (Electrical),
Advanced Vacuum & Logic Control.

Joe developed the Caliburn's unique vacuum control mechanism and computer controlled subsystems.

Peter Denisenko - Bachelor of Arts, Advanced Drive Technology & Vacuum System Design.

Peter's skills in electronics and electrical engineering was used extensively in the optimization of the advanced drive technology used to power the Caliburn's platter, and "stealth-mode" vacuum system.

Arthur Rapos - Bachelor of Engineering (Electrical),
Advanced Motor & RF circuit design

Arthur's understanding of RF circuit design and noise control was used to extract maximum performance from several new technologies used in the Caliburn's design.

Wally Malewicz - Bachelor of Engineering (Mechanical),
Senior Engineering Consultant.

Wally is well known for his dedication to developing tonearm geometry. His "Wally Phono Tools" are used worldwide by discerning audiophiles. Wally worked closely with Mark Doehmann developing the anti-skate mechanism and alignment geometry for the tonearm.

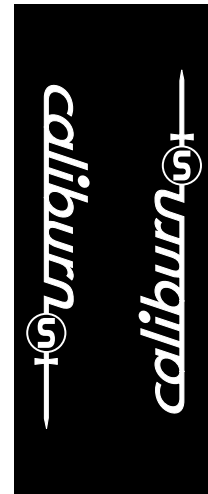

CALIBURN'S DESIGN TEAM

Dr. Nigel Ricketts - Principal Research Scientist CSIRO Manufacturing & Infrastructure Technology, Brisbane.

Nigel was consulted to resolve various metallurgical casting issues to ensure the magnesium properties we specified were transferred to the end product.

Prof. Josef Tomas - Reshape Software and Mechanical Engineering Design. - Josef created the Reshape™ software that allowed us to move resonances inherent in the Caliburn's shape into regions where they could be controlled and managed.

Warwick Freemantle - Bachelor of Arts (Economics), Quality Assurance & Production Process Management. Warwick's critical ear was a valuable aid in the development of the Caliburn.

Dr. Glen Wolff - Advanced Systems Engineering. Glen expertise was sought to deal with the complex use of organic materials and their application on the Cobra.

Thank everyone involved in the manufacturing process, who's names and details can be found on our website.

