

# PAK-BLAST-100

## MANUAL

08.05.04

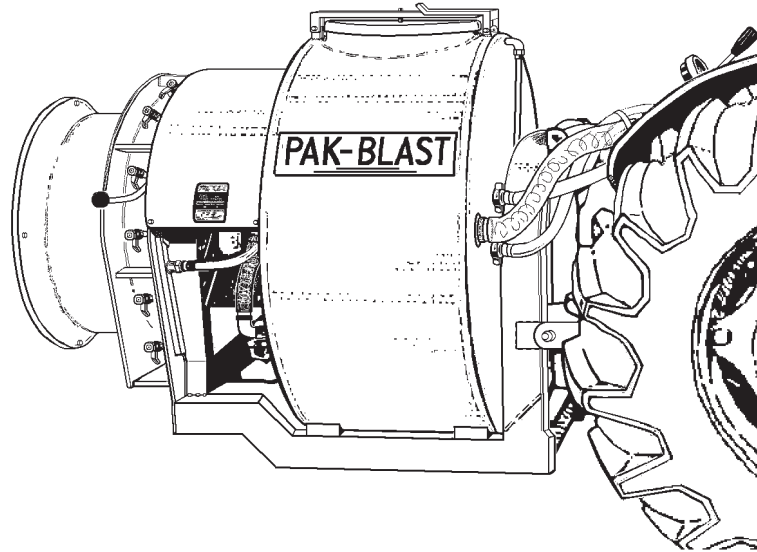

RECORD YOUR PAK-BLAST SERIAL NUMBER HERE

INCLUDE IT IN ANY FACTORY CORRESPONDENCE



**FOR YOUR SAFETY, THE SAFETY OF FELLOW WORKERS AND EQUIPMENT LONGIVITY, READ, UNDERSTAND AND ABIDE BY ALL CAUTION NOTES, COMPLETE ALL INITIAL HOOKUP AND SETUP INSTRUCTIONS BEFORE OPERATING THE PAK-BLAST SPRAYER**



**FOR SAFETY AND EQUIPMENT LONGIVITY,  
Read, Understand, and Abide by all Safety and  
Maintenance Decals duplicated on pages 3.**



## **BEFORE DAILY OPERATIONS**

**FOR YOUR SAFETY, TAKE THE TIME TO CHECK UNIT FOR  
LOOSE FIXTURES, BELTS, NUTS, BOLTS, ETC. . .**

### **OPERATOR'S RESPONSIBILITIES**



**EQUIPMENT DAMAGE DUE TO LOOSE FASTENERS IS THE SOLE RESPONSIBILITY OF  
OPERATOR AND NOT COVERED BY WARRANTY.**

**"MAINTAIN TIGHTNESS OF ALL FASTENERS"**

### **TO RETURN A TANK TO THE FACTORY**

Due to local and national environmental concerns with agricultural spray handling and safety, we at Rear's Manufacturing Company have implemented a policy to regulate the acceptance of spray rig repairs. We will accept only the spray equipment that meets the following standards:

1. All spray equipment will be clean. Spray tanks, pumps, booms, and pumping systems will all be triple-rinsed prior to arrival at our facilities.
2. To prevent freezing of the pump system and to insure a complete flushing of this system all rinsate will be drained from the system prior to arrival at our facility.
3. The exterior as well as the interior of spray equipment should be free of chemical residue. This includes hardened build-up.
4. Rear's vehicles will not transport any spray equipment which has not met these acceptance requirements.
5. The party responsible for the unit will provide a list of all spray materials used in the equipment during the last spray season; specifically identifying the most recent four chemicals. The written and signed statement (form provided by Rear's Mfg Co), signifies an understanding of and compliance with these conditions. The list of chemicals must be included on this form. This form must be completed prior to transport of, or work commencing on, the equipment.
6. These conditions apply to any leased, loaned or traded equipment.
7. Exceptions to these conditions will be by written consent of Rear's Manufacturing Company.

Thank you for your fullest cooperation with all terms for spray unit acceptance. To avoid delays and extra expense, please make sure that your equipment is clean and drained prior to its arrival at Rear's Manufacturing Company; that you have completed our Labor Request Form fully and accurately; and that this signed form accompanies the unit to be repaired.

# Sprayer Safety: Operator Training

Safety is a primary concern in the design and manufacture of our products. Unfortunately, our efforts to provide safe equipment can be wiped out by a single careless act of an operator.

In addition to the design and configuration of equipment, hazard control and accident prevention are dependent upon the awareness, concern, prudence and proper training of personnel involved in the operation, transport, maintenance and storage of equipment.

It has been said, *the best safety device is an informed, careful operator*. We ask you to be that kind of an operator. It is the operator's responsibility to read and understand all safety and operating instructions in the manual and to follow these. Accidents can be avoided.

Working with unfamiliar equipment can lead to careless injuries. *Read this manual and the manual for your tractor* before assembly or operation, to acquaint yourself with the machines. If this machine is used by any person other than the owner or is loaned or rented, it is the owner's responsibility to make certain that the operator has instruction for the safe and proper use of the machinery and that the operator reads and understands the operator's manuals.

Know your controls and how to stop the tractor, engine, and implement quickly in an emergency. Read this manual and the one provided with the tractor.

Train all new personnel and review instructions frequently with existing workers. A person who has not read and understood all operating and safety instructions is not qualified to operate the machine. An untrained operator exposes himself and bystanders to possible serious injury or death.

Do not allow children to operate this machine.



READ THE OPERATOR'S MANUAL

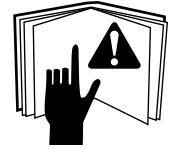

READ THE OPERATOR'S MANUAL

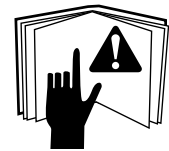

READ THE OPERATOR'S MANUAL

**Read this manual completely before operating: follow all safety instructions.**

# Sprayer Safety: Preparation

Never operate the tractor and implement until you read and completely understand this manual, the tractor operator's manual, and each of the safety messages found on the safety decals on the tractor and the implement.



Personal protection equipment, including a hard hat, safety glasses, safety shoes, and gloves are recommended during assembly, installation, operation, adjustment, maintenance, repair, removal, or transport of this implement. Do not allow long hair, loose fitting clothing or jewellery to be around moving parts.



Tractors, with or without implements, can often be noisy enough to cause permanent, partial hearing loss. We recommend that you wear hearing protection on a full-time basis if the noise in the operator's position exceeds 80db. Long-term exposure to noise over 85db can cause severe hearing loss. Long-term exposure to noise over 90db may cause permanent, total hearing loss. **NOTE: Hearing loss from loud noise (from tractors, chain saws, radio earphones) is cumulative over a lifetime without hope of natural recovery.**

Operate the implement only with a tractor equipped with an approved Roll-Over-Protection-System (ROPS). Always wear your seat belt. Serious injury or even death could result from falling off a tractor— particularly during a turnover, when the operator could be pinned under the tractor.

Operate only in daylight or good artificial light.

Ensure the implement is properly mounted and in good operating condition.

Safety shielding and safety decals must be properly installed and in good condition.

# Sprayer Safety: Starting & Stopping

Implement operating power is supplied from the tractor's PTO. Refer to your tractor manual for PTO engagement and disengagement instructions. Always operate the implement at its required PTO speed: either 540 or 1000 rpm. Know how to stop the tractor and implement quickly in case of an emergency. Keep children away at all times.

When engaging the PTO, the engine RPM should always be low. Once engaged, raise the PTO speed to the implement's required operating speed: either 540 or 1000 rpm.

Check the tractor master shield over the PTO stub shaft. Make sure it is in good condition and fastened securely to the tractor. Purchase a new shield if the old shield is damaged or missing. A tractor salvage yard is a good source for older tractors.

Tractors without a *live* PTO need to be equipped with an over-running PTO clutch attachment, available through most farm equipment suppliers. NOTE: the addition of an over-running PTO clutch attachment will change the length of the PTO driveline required. Pay extra attention to the instructions on PTO driveline installation.

# Sprayer Safety: Chemicals

Never provide agricultural chemicals to anyone unless that person has been properly trained or licensed.

Make certain the entire manufacturer's label appears on the chemical container. Always follow the manufacturer's instructions for storage, handling, and application.



Before a spraying operation is started the spray system should be rinsed and all nozzles, screens, and strainers cleaned. The best time to rinse and clean the spray system is at the END of daily operations, before storing the implement for the night. If cleaning is conscientiously included in day-end procedures, rinsate and the disposal of cleaning solution can easily be incorporated into your spray plan. Be careful if re-applying rinse solution to treated area: do not exceed the maximum rate for which the chemical is labeled.

Wear proper protective equipment when adding chemicals to the spray tank. The area where you are mixing must have adequate ventilation: powders, dust, and granuals can become airborne when adding to the spray tank; concentrated vapors can pose health or flammability hazards.

Mix only enough chemical for the particular job. Preventing chemical surplus is the best way to prevent a disposal problem.

Be aware of meteorological conditions and plan spray applications during opportune times. High winds and low humidity will increase drift and adversely affect your spray program.

Be alert for nozzle clogging and changes in nozzle patterns. Use strainers and nozzle screens appropriate for your water source and chemical use.

Use a brush or wood toothpick to clear nozzles- never a metal object. A metal object can damage the spray orifice and significantly alter your application rate. Never attempt to clear a spray tip by blowing through it. Operators should carry spare spray tips.

If nozzles clog or other troubles occur in the field, shut the sprayer off and move to an unsprayed area before dismounting from the sprayer to work on it.

The skin on various body parts does not absorb pesticides at the same rate. The figure, right, illustrates skin absorption rates based on a numerical scale in which the value of 1 for the forearm represents the lowest dermal absorption rate. That value forms the basis for the assignment of values to the other body parts.

If concentrated liquid chemical is spilled on your clothing (not including rubber gloves, boots, or aprons) immediately remove the clothing and throw away. Undiluted chemicals cannot be cleaned from clothing. Dispose of contaminated clothing as required by local regulations.

Always treat clothes worn when using agricultural chemicals as contaminated. Keep them separate from your other clothes or the family washload.

Contact your local extension service for instructions for cleaning work clothes contaminated by chemical handling. Most state agricultural universities and farm bureaus have detailed instructions for the decontamination of work clothes.

Line dry your work clothes to avoid contaminating your dryer.

Chemical resistant gloves make a big difference BUT don't rub contaminated gloves on your skin. **A good safety practice before eating, drinking, smoking, or using the bathroom: rinse your gloves thoroughly BEFORE removing them then take off your gloves and wash your hands.**

Trained personnel should thoroughly clean the inside and outside of mixing and application equipment immediately after use. Follow all chemical handling directions supplied by the manufacturer and wear recommended safety equipment. Clean and neutralize the pump system, spray manifolds, and spray tank as recommended by the chemical manufacturer. Cleaning between implement uses will reduce corrosion, extend pump life, and keep your chemical tools from reacting with residual incompatible mixes.

Always follow the chemical manufacturer's instructions and environmental regulations when disposing of chemical waste and empty chemical containers.

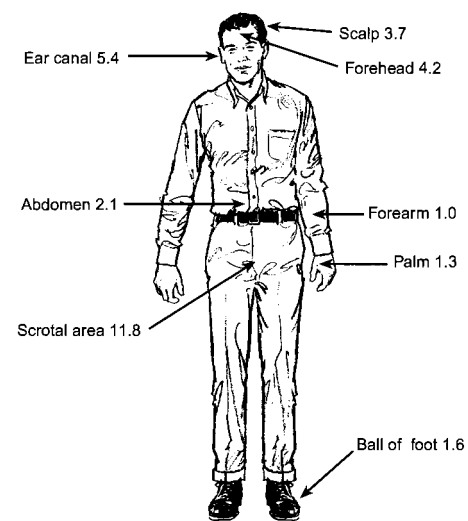

**Skin absorption rates**  
in relation to forearm (1.0)

The information included in this **Chemical Safety** section was compiled from the following government and community education programs:

*Oregon Occupational Safety & Health*

*Alliance for a Clean Rural Environment*

*University of Missouri Outreach & Extension*

*California Dept. of Pesticide Regulation*

All listed source organizations have more detailed information on the internet.

# Sprayer Safety: Pre-operation

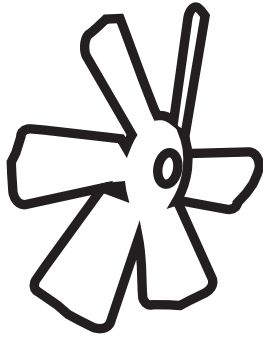

Install and secure all guards and shields before starting or operating.

**Frequently check fan blades.** They should be free of nicks and cracks. The fan guard must be kept clean and in good repair.

The mechanical cabinet access guards, fan guard, sag chains, driveline shields, and gearbox shields should be used and maintained in good working condition. They should be inspected carefully, at least daily, for missing or broken cable, chain links, shields, or guards. Missing, broken or worn items must be replaced at once to reduce the possibility of injury from thrown objects or entanglement.

Check that all fasteners are tight.

Always follow the chemical manufacturer's instructions for storage, handling, and application of agricultural chemicals. When handling spray equipment, valves, nozzles, strainers: wear the safety equipment recommended by the chemical manufacturer.

Before a spraying operation is started, rinse out the sprayer; remove and clean all nozzles, nozzle screens and strainers. Make sure all spray orifices are sized correctly for your application and not worn. Use strainers and nozzle screens appropriate for your water source and chemical use.

Check all lines, valves and seals for leaks after filling with water and during calibration. Replace all weather cracked or worn hoses.

Wear proper protective equipment when adding chemicals to the spray tank. The area where you are mixing must have adequate ventilation: powders, dust, and granules can become airborne when adding to the spray tank; concentrated vapors can pose health or flammability hazards.

Always follow the chemical manufacturer's instructions and environmental regulations when disposing of chemical waste and empty chemical containers.

Mix only enough chemical for the particular job. Preventing chemical surplus is the best way to prevent a disposal problem.

Have a plan for application of end-of-day tank-mix and rinse water. In some cases small amounts of surplus chemical can be diluted and reapplied to the treated area. Always follow the manufacturer's application instructions. Do not exceed the maximum application rate for which the chemical is labelled.

Be aware of the meteorological conditions and plan spray applications during opportune times. High winds and low humidity will increase drift and adversely affect your spray program.

Avoid spraying near lakes, streams, pastures, population areas (houses, schools, playgrounds, hospitals) beehives or sensitive non-target crops. Always spray downwind from these sensitive areas and do not spray during adverse wind or low humidity conditions.

Follow your sprayer lubrication schedule.

# Sprayer Safety: Operation

The use of this equipment is subject to certain hazards which cannot be protected against by mechanical means or product design. All operators of this equipment must read and understand this entire manual, paying particular attention to safety and operating instructions, prior to use. If there is something in this manual you do not understand, ask your supervisor, dealer, or call the manufacturer.

Most accidents occur because of neglect or carelessness. Keep all helpers and bystanders at least several hundred feet away from the operating implement. Only properly trained people should operate this machine. Keep children away at all times.

The majority of accidents involve entanglement on a driveline, and operators being knocked off the tractor by low hanging limbs and run over. Accidents are most likely to occur with untrained operators or machines that are loaned or rented to someone who has not read the owner's manual and is not familiar with the implement.

Always stop the tractor, set the brake, shut off the engine, remove the ignition key before dismounting the tractor. **Never leave equipment unattended with the tractor running.**

Never place any part of your body in the mechanical compartment with tractor engine running or before you are sure all motion has stopped.  
Stay clear of all moving parts.

Do not reach or place yourself under equipment until it is blocked securely.

Engage the PTO at low RPM and then bring the PTO speed up to operating speed.

Do not engage the implement PTO with the tractor and implement at right angles. Lessen strain on drivetrain by starting PTO when tractor and implement are in-line.

PAKBLAST AND PULBLAST UNITS: Never engage the fan at high speed.

POWERBLAST UNITS: When engaging the fan clutch the engine speed should be 1000RPM. Engaging the clutch at this speed, not greater or less, will ensure long clutch life.

Do not disengage the PTO while turning.

Take all possible precautions when leaving unit unattended: disengage PTO, set parking brake, stop engine, and remove key from ignition.

Do not allow riders on the implement or tractor at any time. There is no safe place for any riders.

Disengage PTO and place transmission into neutral before attempting to start the engine.

Do not operate unless all personnel, livestock, and pets are out of your application area. Never direct discharge toward anyone. Keep children away at all times.

Inspect the entire machine periodically as indicated in the maintenance section of this manual. Look for loose fasteners, worn or broken parts, pinched hydraulic hoses, and leaky or loose fittings. Make sure all pins have cotter pins and washers. Serious injury may occur from not maintaining this machine in good working order. Install and secure all guards and shields before starting or operating.

Keep hands, feet, hair, and clothing away from all moving parts.

This implement is designed for use only on tractors with 540/1000 RPM power-take-off. **DO NOT EXCEED YOUR IMPLEMENT'S RATED PTO SPEED.**

If possible when applying chemical, work your way up-wind through your application area. By approaching the application such that drift goes into already treated rows the amount of chemical that will be blown onto the operator is reduced.

Be alert for nozzle clogging and changes in nozzle patterns. If nozzles clog or other troubles occur in the field, shut the sprayer off and move to an unsprayed area before dismounting from the tractor.

Never try to unclog a nozzle by blowing through it. Always carry extra spray tips.

Never operate tractor and implement under trees with low hanging limbs: the operator can be knocked off the tractor and run-over.

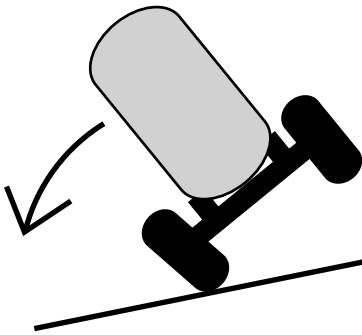

Stay alert for holes, rocks and roots in the terrain and other hidden hazards. Keep away from drop-offs.

Use extreme care and maintain minimum ground speed when transporting on hillside, over rough ground and when operating close to ditches or fences. Be careful when turning sharp corners.

Reduce speed on slopes and sharp turns to minimize tipping or loss of control. Be careful when changing directions on slopes. Do not start or stop suddenly on slopes. Avoid operation on steep slopes.

When using an implement, 20% of the combined tractor and implement weight (at a minimum!) must be on the tractor's front wheels. Without this weight, the tractor could tip over, causing personal injury or death. The weight may be attained with a front end loader, front wheel weights, ballast in the tires or front tractor weights. When attaining this minimum 20% front wheel weight, you must not exceed the ROPS weight rating. Weigh the tractor and the implement. Do not guess or estimate!

Be careful when operating the tractor and implement on uneven ground to avoid upsetting.

In extremely uneven terrain, front wheel weights, front tractor weights, and/or tire ballast should be used to improve stability.

Pass diagonally through sharp dips and avoid sharp drops to prevent *hanging up* the tractor and implement. Practice improves skills in maneuvering rough terrain.

Avoid sudden starts and stops while travelling up or downhill.

Always travel down slopes, never across the face. Avoid operation on steep slopes. Slow down on sharp turns and slopes to prevent tipping and/or loss of control.

# Sprayer Safety: Tires

Failure to follow proper procedures when mounting a tire on a wheel or rim can produce an explosion which may result in serious injury or death.

Do not attempt to mount a tire unless you have the proper equipment and experience to do the job.

Inflating or servicing tires can be dangerous. Whenever possible, trained personnel should be called to service and/or mount tires.

Always order and install tires and wheels with appropriate capacity to meet or exceed the anticipated weight to be placed on them.

# Sprayer Safety: Maintenance

Good maintenance is your responsibility. Poor maintenance is an invitation to trouble.

Follow good shop practice. Keep service area clean and dry. Be sure electrical outlets and tools are properly grounded. Use adequate light for the job at hand.

Make sure there is plenty of ventilation. Never operate gas/diesel engines in a closed building. The exhaust fumes may cause asphyxiation.

When handling spray equipment, pumps, valves, nozzles, strainers: wear the safety equipment recommended by the chemical manufacturer. Before working on the equipment, be certain the components are clean and neutralized as instructed by the chemical manufacturer.

Before working on this machine, disengage the PTO, shut off the engine, set the brakes and remove the key from the ignition.

Be certain all moving parts on tractor and implement have come to a complete stop before attempting to perform maintenance.

Never work under equipment unless it is blocked securely.

When performing any service or maintenance, always use personal protection devices such as eye, hand and hearing protection.

Trained personnel should thoroughly clean the inside and outside of equipment immediately after use. Follow all chemical handling directions supplied by the manufacturer and wear recommended safety equipment. Clean and neutralize the pump system, spray manifolds, and spray tank as recommended by the chemical manufacturer. Cleaning between implement uses will reduce corrosion, extend pump life, and keep your chemical tools from reacting with residual incompatible mixes.

Frequently check fan blades. They should be free of nicks or cracks and kept clean.

Periodically tighten all bolts, nuts and screws and check that all cotter pins are properly installed to insure unit is in a safe condition.

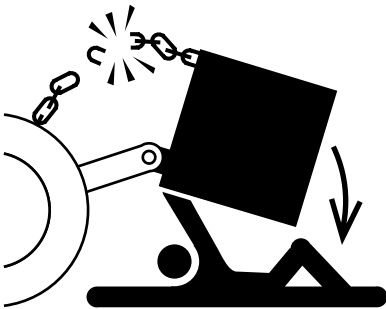

When completing a maintenance or service function, make sure all safety shields and devices are installed before placing the unit back in service.

Remove hydraulic pressure prior to doing any maintenance. Block the implement securely, disengage the PTO, and turn off the engine.



Never use your hands or any part of your body to locate a hydraulic leak. Use a piece of cardboard or wood to pass along the hydraulic line and determine the location of any leak. Wear protective gloves and glasses. Hydraulic fluid escaping under pressure can penetrate the skin. Openings in the skin and minor cuts are susceptible to infection from hydraulic fluid. If injured by escaping hydraulic fluid, see a doctor at once. Gangrene and death can result. Without immediate medical treatment, serious infection and reactions can occur.

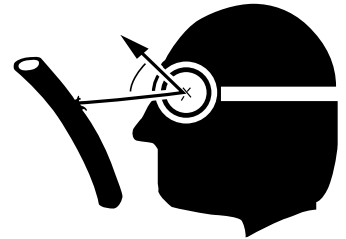

When disconnecting hydraulic lines, shut off supply: relieve all hydraulic pressure.

Before pressurizing system, inspect all components. Make sure fittings are tight and lines are not worn, kinked or damaged.

After servicing, be sure all tools, parts and service equipment are removed.

Do not allow grease or oil build up on any deck or platform.

Never replace hex bolts with less than grade 5 bolts unless otherwise specified, i.e. shear bolts. Refer to bolt torque chart for head identification markings.

Where replacement parts are necessary for periodic maintenance and servicing, genuine factory replacement parts must be used to restore your equipment to original specifications. The manufacturer will not claim responsibility for use of unapproved parts and/or accessories and other damages as a result of their use.

If equipment has been altered in any way from the original design, the manufacturer does not accept any liability for injury or warranty.

A fire extinguisher and first aid kit should be kept readily accessible while performing maintenance on this or any equipment.

**Read this manual completely before operating: follow all safety instructions.**

# Sprayer Safety: Transport

Comply with state and local laws governing highway safety and movement of farm machinery on public roads.

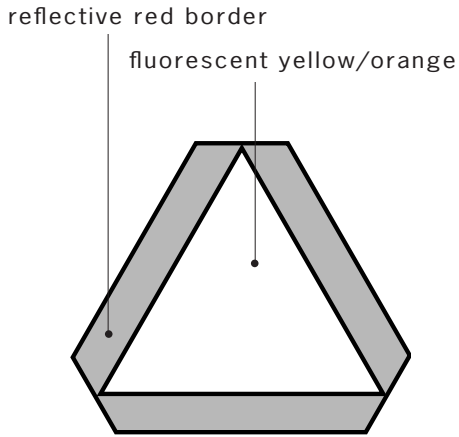

**slow moving vehicle emblem**

The use of flashing amber lights is acceptable in most localities. However, some localities prohibit their use. Local laws should be checked for all highway lighting and marking requirements.

When driving the tractor and equipment on the road or highway under 20mph (32kph) at night or during the day, use flashing amber warning lights and a slow moving vehicle identification emblem (SMV).

Plan your route to avoid heavy traffic.

Always install transport locks, pins or brackets before transporting.

Do not drink and drive.

Watch out for traffic when operating near or crossing roadways.

When driving hills or curves, slow down and make gentle turns. Make certain that at least 20% of the total weight of tractor and implement is on the front wheels to maintain safe steering. Slow down on rough or uneven surfaces.

Use extreme care and maintain minimum ground speed when transporting on hill-sides, rough ground, or when travelling close to ditches and fences. Be careful when steering around sharp corners.

Never allow riders on either the tractor or implement. Falling off can kill.

Be a safe and courteous driver. Always yield to oncoming traffic in all situations, including narrow bridges, intersections, etc.

Do not exceed 20mph (32kph). Reduce speed on rough roads and surfaces.

Use hardened hitch pins with retainers when attaching to pull-type machines.

Use a safety chain to prevent unexpected separation with pull-type models.

# Sprayer Safety: Storage

With pull-type units, never unhitch the implement without using the tongue jack. The tongue is very heavy. Attempting to lift the tongue without using the tongue jack could cause personal injury. Overloading the jack can cause failure with possible serious injury or even death.

Trained personnel should thoroughly clean the inside and outside of equipment immediately after use. Personnel should wear protective equipment as recommended by the chemical manufacturer.

Before storing the sprayer for an extended period flush the plumbing with a light weight oil mixture with water (approx. 1 gallon of oil for 40 gallons of water). When draining spray manifolds, remove the check-valve cap from the top-most nozzle assembly to release vacuum. Flush pump and system with RV antifreeze solution and leave solution in the pump for storage. Remove nozzle tips and screens and store in a can of light oil to prevent corrosion. Plug the nozzle openings with blanks.

Lubricate as instructed in the maintenance schedule.

Inspect all lines, hoses, valves before storing. Damage to pump and plumbing should be repaired before storage. Make a list of replacement parts needed and order early. For the best performance next season, have your dealer service the machine prior to storage.

Re-paint all parts where the paint has been worn.

Store the implement away from activity.

Do not park equipment where it will be exposed to livestock. Damage to equipment or injury to livestock could result.

Do not permit children to play on or around the implement.

Make sure the parked unit is on a hard, level surface with all safety devices in place and in good working condition. Block up frame to lighten load on tires. Do not deflate tires. Cover tires if exposed to sunlight, grease, or oil.

**Read this manual completely before operating: follow all safety instructions.**

# Sprayer Safety: Safety Decals



This is the SAFETY-ALERT symbol. This symbol is used to visibly mark operating hazards. YOU MUST FOLLOW THE DIRECTIONS POSTED BESIDE THE SAFETY-ALERT SYMBOL TO AVOID BODILY INJURY OR DEATH. Before you operate any machinery, read the operator's manual. A copy of every SAFETY-ALERT decal on your implement is included in your operator's manual with a map of each decal on your implement. With your operator's manual in hand, walk around the implement: find, read, and UNDERSTAND every SAFETY-ALERT decal.

**EVERY OPERATOR OF THIS IMPLEMENT MUST DO THIS FOR THEIR OWN SAFETY.**

On Safety Decals, there is often a signal word: DANGER, WARNING, CAUTION. These signal words indicate the level of hazard or degree of seriousness for the described hazard on the decal.



Indicates a potentially hazardous situation that, if not avoided, may result in minor or moderate injury.



Indicates a potentially hazardous situation that, if not avoided, may result in death or serious injury.



Indicates an area of extreme danger- machine components and hazardous operations that, for functional purposes, cannot be guarded and, if not avoided, could result in death or serious injury.



Warns the operator of potential machine damage if indicated procedure is not followed.

## decals won't help if you can't read them

Keep safety decals clean and legible at all times and replace safety decals that are missing or have become illegible.

When parts that bear safety decals are replaced, the replacement parts must have a current safety decal. Safety decals are available from your dealer or direct from the manufacturer.

## install the decals properly and they'll stick around

When applying a safety decal, be sure the application surface is clean (free of dirt and grease) and dry. The surface you are applying the decal to should be above 50°F (10°C).

# + CAUTION

1. Keep All Shields in Place.
2. Before Servicing, Adjusting or Working on Machine: Disengage Power, Shut Off Engine and Make Sure All Moving Parts Have Stopped.
3. Do Not Stand Near Machine When In Operation.



Rear's Mfg. Co.  
2140 Prairie Rd.  
Eugene, OR 97401



**THIS UNIT NOT INTENDED FOR HIGHWAY USE**

**DANGER**  
SHIELD MISSING  
DO NOT OPERATE!  
Decal 93

**CAUTION**  
AGRICULTURAL CHEMICALS CAN BE DANGEROUS. improper selection or use can seriously injure persons, animals, plants, soil, or other property. Be safe: select the right chemical for the job. Handle it with care. Follow instructions on container label and from equipment manufacturer.  
Decal 96

**WARNING**  
HIGH-PRESSURE FLUID HAZARD  
- Relieve pressure on system before repairing or adjusting.  
- Wear proper hand and eye protection when searching for leaks. Use wood or cardboard instead of hands.  
- Keep all components in good repair.  
FAILURE TO FOLLOW THESE INSTRUCTIONS COULD RESULT IN SERIOUS INJURY OR DEATH  
Decal 91



## SPRAYER MAINTENANCE

**DO NOT RUN PUMP WITH SUCTION VALVE CLOSED!**

- \* HYPRO NYLON ROLLER PUMPS — Do not run dry.
- \* HYPRO PISTON PUMPS — Grease daily, do not run with leaking piston cups.
- \* HYPRO CENTRIFUGAL PUMPS — Do not run dry.
- \* WANNER PUMPS — Grease daily (preferably when bearings are warm). And before storage. If leakage should occur from weep hole, immediately replace cups.
- \* A/R PUMP — Keep oil (30 WT.) up to neck on transparent filler tube.
- \* PRESSURE — If pressure drops check for possible cause in the following order:  
1. Plugged suction.  
2. Worn relief valve (after tightening valve the fluid continues to by-pass indicates worn valve, repair).  
3. Worn pump valves. 4. Worn nozzles.
- \* PULSATION — Diaphragm and piston pumps are fitted with air-dome to reduce pulsation. Rule of thumb pressure setting— 1/10 working pressure in air-dome when pump is not operating. Minor air dome pressure change can make significant change in pulsation. Adjust air-dome pressure for smoothest performance.
- \* BELT DRIVE — Keep adjusted.
- \* U-JOINTS & AGITATOR — Grease daily, being careful not to over-grease.
- \* LINE STRAINER — Check often, keep clean.
- \* DAILY TANK & PLUMBING CARE — Flush out unused chemicals daily to prevent caking and plugging of screens and nozzles.
- \* WINTER STORAGE — Flush and drain entire system. Make sure no water is trapped in pump.

**DO NOT RUN PUMP WITH SUCTION VALVE CLOSED!**

**REAR'S MANUFACTURING COMPANY**  
Eugene, Oregon  
"HOME OF PUL-TANK AND PAK-TANK SPRAYERS"

**CAUTION**  
BEFORE MIXING SPRAYS OR SPRAYING BE SURE YOUR PROTECTIVE CLOTHING, GLOVES, FACE SHIELD AND RESPIRATOR ARE ALL IN PERFECT CONDITION.  
READ AND OBSERVE ALL PRECAUTIONS ON LABELS OF MATERIALS BEING USED.  
BE A GOOD NEIGHBOR; DO NOT SPRAY UNDER CONDITIONS THAT WILL CAUSE DRIFT FROM THE TARGET AREA.  
REAR'S MANUFACTURING  
EUGENE, OREGON

## PAK-BLAST 3-PT MOUNTING INSTRUCTIONS

1. Position the Pak-Blast Sprayer on a level surface
2. Hookup the tractor Lift-Arms "after" attaching the Anti-Sag Brace Chains to the Tank Lift Pins as illustrated below.
3. Hookup the two "un-bolted" Top-Link halves to their respective attachment points. Be certain the chain "Eyelet Brackets" are in place, one on each side of the tractor half of the Top-Link as illustrated below. Bring the two halves together and temporarily install the bolts in the closest holes.
4. Raise the tractor lift arms until the tank is "above" its level point. Hookup the two "Anti-Sag Brace Chains (equal in length) in their respective Eyelet Brackets.
5. Lower the lift-arms. A filled tank should be level at this point. If the tank is not level, and is lower in the rear, repeat steps 3 and 4 with the fan end of the Pak-Blast blocked up with one or more 2x4s so the Top-Link "BOLTS" can be re-adjusted to the next closest holes.
6. Once the Pak-Blast is levelled, attach the Drive-Line to the tractor power-take-off.

... Initial instructions continue on the following page.

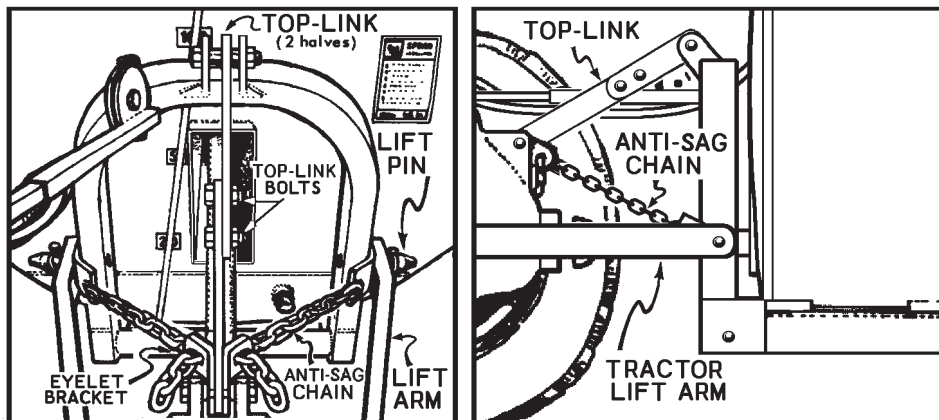

**IMPORTANT:** When levelling an empty Pak-Blast, you need to allow for "filled tank weight" by "slightly" over-adjusting the Top-Link so that the rear of the Pak-Blast (fan end) is higher than the front when the tractor Lift-Arms are lowered.

## BEFORE DAILY OPERATIONS

FOR YOUR SAFETY, TAKE THE TIME TO CHECK UNIT FOR  
LOOSE FIXTURES, BELTS, NUTS, BOLTS, ETC. . .

### OPERATOR'S RESPONSIBILITIES

EQUIPMENT DAMAGE DUE TO LOOSE FASTENERS IS THE SOLE RESPONSIBILITY OF  
OPERATOR AND NOT COVERED BY WARRANTY.

**"MAINTAIN TIGHTNESS OF ALL FASTENERS"**

**CAUTION: NEVER OVER SPEED THE PUMP: UNNECESSARY WEAR AND POSSIBLE DAMAGE MAY OCCUR.**

# INITIAL OPERATIONS/PRECAUTIONS

(PLEASE READ AND UNDERSTAND THOROUGHLY - BEFORE BEGINNING OPERATIONS)

## LUBRICATION:

Use **TEXACO NO.2 CHASSIS GREASE** or equivalent; apply two (2) shots of grease to each pto u-joint; agitator bearings utilize impregnated bronze bushings which require minimal attention, apply grease lightly, stopping when resistance is felt... "NEVER OVER GREASE," excess will enter tank.

## BEFORE OPERATING PUMP:

1. Fill tank with water above pump level (Open Suction Valve).
2. Check/Maintain Pump Oil Level (keep above halfway mark on transparent plastic fill tube).
3. Check All Suction Lines For Tightness.
4. Check Strainer(s), keep clean and tight.
5. Clear Air From Pump and system Lines: fully open relief valve - open discharge to tank and run for several minutes at zero pressure circulating liquid.

## TO OBTAIN PUMP PULSATION CONTROL:

1. Shutdown pump.
2. Relieve system pressure.
3. Add air to airdome (40 to 50 psi).
4. Start-up pump, attain working pressure.
5. Bleed off air "in very small amounts" until pulsation has ceased or is reduced to its minimum.

**NOTE:** If "minimum" pulsation is passed and pulsation begins to "increase" repeat steps 1 through 5. Adjust Pressure Regulator to comply with your specific needs.

## KEEP SUCTION STRAINER CLEAN:

Check and clean Suction Strainer often, ideally between refills, especially when using less than clean ditch or well water and some harsh chemicals.

**IMPORTANT:** The sole purpose of the suction valve is to shut-off flow if suction strainer requires cleaning while tank has liquid in it. **NEVER CLOSE SUCTION VALVE** while system is running: pump damage can occur. Operating with a Clogged Strainer will have Equal Results.

**SET-UP** handgun or spray boom attachment to be used.

**ENGAGE** tractor pto/or start gas engine drive. Water flow should show through clear suction hose to pump. Some pressure should show on gauge.

## RELIEF VALVE:

To ensure proper priming of pump and prevent possible water hammer action that could cause glycerin pressure gauge damage, fully open Relief Valve.

## SET A WORKING PRESSURE:

To accurately set a prescribed working pressure, handgun/spray boom has to be on and spraying: Turn the handgun or spray boom on and adjust the relief valve until your working pressure is attained. When handgun/spray boom is turned off, the pressure will show an increase at pressure gauge.

## AFTER 1 HOUR OF INITIAL OPERATION:

Recheck tightness of all nuts and bolts, set-screws, belts, etc., as previously described. It is good practice to make this check each time the machine is being serviced.

**CAUTION: NEVER OVER SPEED THE PUMP "UNNECESSARY WEAR AND POSSIBLE DAMAGE MAY OCCUR." OPERATE AT OR BELOW TRACTOR PTO "540 RPM."**

# SETUP A PUMP AND SYSTEM MAINTENANCE ROUTINE

## PREVENT DAMAGING CHEMICAL BUILDUP:

AFTER DAILY USE, fully open Relief Valve to discharge back to tank. Engage pump and run two or three minutes at ZERO pressure on gauge, circulating clean water through the pump several minutes to reduce harmful chemical buildup. Proper maintenance will greatly extend the life of hoses, seals, screens, nozzles, pump valves, and diaphragms, especially when harsh chemical are used. Check and Clean Suction Strainer Screen.

## CHECK HOSE LINES & FITTINGS:

Check all hose lines and fittings for no-leak tightness.

## PUMP:

**MAINTAIN PUMP OIL LEVEL:** Keep pump oil level above half-way mark on filler tube. When low, add a good grade non-detergent motor oil (30wt).

## CHANGING PUMP OIL:

Pump oil change should occur every 200 hours or at end of season, whichever comes first. When changing the oil, inspect the diaphragms and valves: you are looking for diaphragm swelling or stretching and wear check marks, also valve seat wear and valve spring fatigue. Refill pump with a good grade non-detergent motor oil (30wt). Rotate the shaft while filling to ensure complete air evacuation from pump body. This oil change and maintenance check ensures greater trouble free operations throughout each season.

## SEASONAL STORAGE & WINTERIZING (**WARNING: Do Not use Diesel Oil in this process**):

1. Fully flush system, recirculating "clean" water.
2. Fully flush again, recirculating a sufficient ANTI-FREEZE solution.
3. Shutdown, leaving sufficient ANTI-FREEZE solution in pump, tank, and throughout system.

**NOTE:** The ANTI-FREEZE solution is determined regarding winter temperatures in your area.

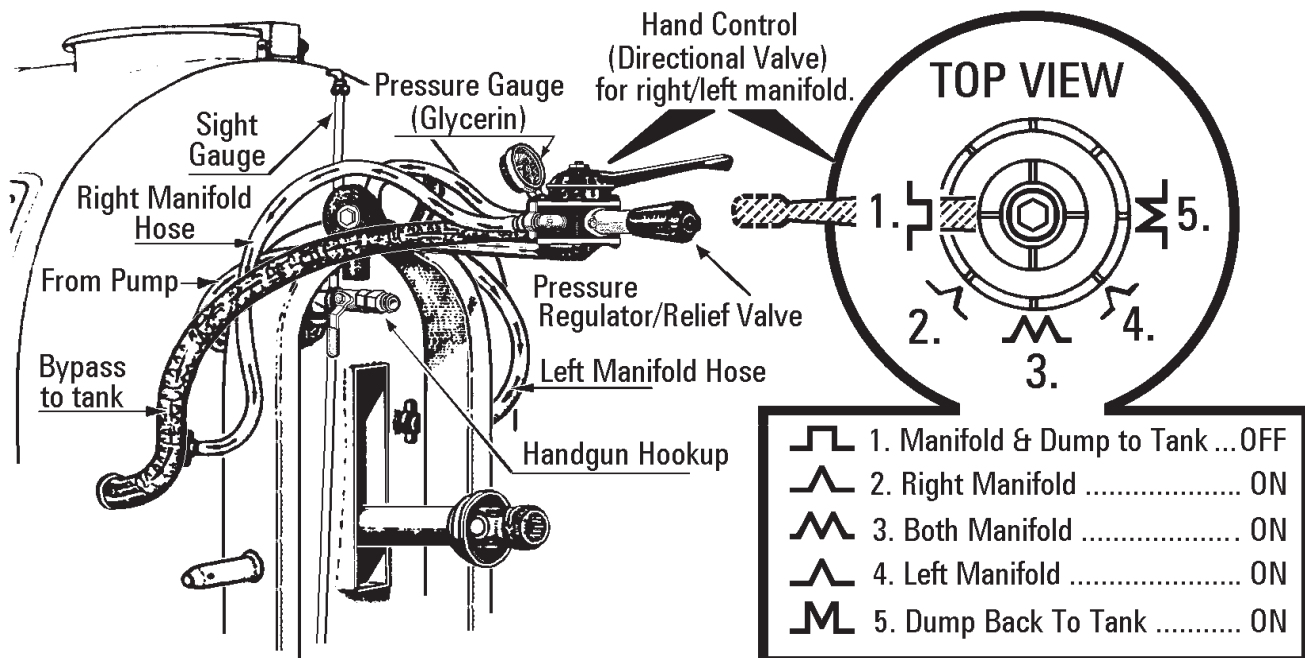

**CAUTION: NEVER OVER SPEED THE PUMP "UNNECESSARY WEAR AND POSSIBLE DAMAGE MAY OCCUR." OPERATE AT OR BELOW TRACTOR PTO "540 RPM."**

## AR50 PUMP OPERATIONS

### MAINTAIN PROPER OIL LEVEL

The crankcase oil plays a dual role. It lubricates all moving parts and hydraulically supports the diaphragm on the pressure stroke. Therefore, to assure maximum performance it is important to maintain recommended oil level marked on the transparent filler spout.

### HOW THE AR PUMP WORKS

Each piston "DOWNSTROKE" lowers the piston-attached-diaphragm, drawing spray chemical into "upper" diaphragm cavity. As piston ring passes below cylinder sleeve side openings, oil of "lower" diaphragm cavity is expelled. Each piston "UPSTROKE" draws a precise amount of oil back into "lower" diaphragm cavity expanding diaphragm as piston "tops-out." This discharges chemical spray contents of "upper" diaphragm cavity. The "lower diaphragm cavity" oil cushion" also lubricates diaphragm, washer, and piston insuring minimal mechanical wear on diaphragm(s). *Remember* "Low Oil Level Lowers Performance, and causes excessive mechanical wear on diaphragm." The transparent oil spout makes oil checks easy. Keep filled to mark on lower spout.

### DO NOT RUN PUMP WITH A STARVED SUCTION

The diaphragm pump will not suffer if run dry due to an empty tank. However, a "starved" suction due to a "clogged" strainer or a "closed" suction valve will cause premature failure of the pump diaphragm(s). When mixing powders into solution you can avoid clogging the suction strainer screen by "sluicing" heavy concentrations of wetttable powders "through the lid basket screen" into an already "half-filled" tank while system is running. Agitator paddles will mix powders into solution that would otherwise settle to the bottom of tank in bulk to be drawn into the suction line clogging strainer screen.

### SUCTION VALVE (To Prevent Possible Pump Damage SHUTDOWN SYSTEM Before Closing The Suction Valve)

This valve is in the system to close off tank liquid flow to effect emergency system repair or if strainer "screen" requires unexpected cleaning after a tank refill (considering water source, strainer screen should be cleaned just before each tank refill).

### DO NOT OVER SPEED PUMP

AR is designed to operate at or below a specific speed. Over speeding will cause valves to prematurely fail and could cause other internal damage. Refer to the "performance chart" of your specific pump for "maximum" operating speed.

### BEFORE OPERATING SYSTEM

Check "tightness" of suction line fittings and strainer cap, Read airdome information to set air to 1/10th working pressure.

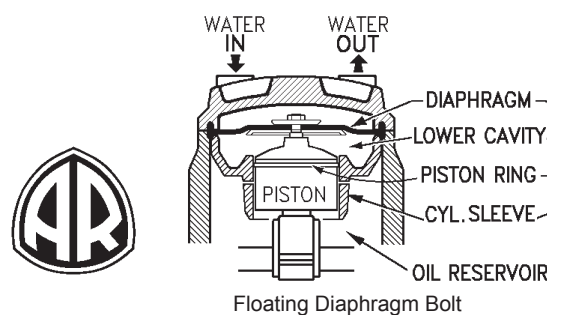
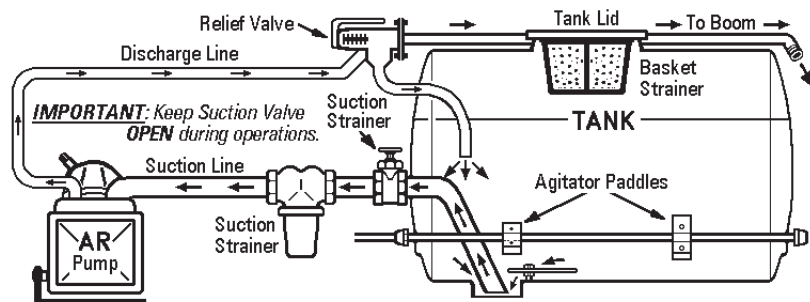

### AIRDOME INTRODUCTION

It is the nature of piston and piston-like pumps (i.e. diaphragm pumps) to have some pulsation or water hammer action. This is caused by sudden change in piston direction. The airdome pulsation dampener has one function in the pumping system: reduce pulsation by providing a cushion of air to bump against. The AR airdome uses a rubber bladder to separate the "air cushion" from solution being pumped. The bladder eliminates water logging problems common in static-air type dampeners.

### AIRDOME SETTING WITH PRESSURE GAUGE

The basic rule is to fill the airdome with air equal to ten percent of the system working pressure: If you have a handgun pressure set at 100 psi, the setting for the airdome should be 10 psi. Always shutdown pump before adding air to airdome. Air supply may be from a compressor or manual type pump. The sphere containing air is small, making pressure checks something of a challenge. Take care applying the pressure gauge "evenly" on the air valve to prevent air from leaking out of airdome. It is not uncommon to lose 5-10 psi checking pressure.

### SETTING PRESSURE WITHOUT A PRESSURE GAUGE

To set pressure without a pressure gauge, watch the vibration of the "discharge hose." With zero airdome pressure, add air to airdome. 70 - 80 psi is sufficient for 700 psi working pressure. Run pump and adjust relief valve to desired working pressure. Vibration should occur. Now, "slowly" bleed off the airdome while watching pump discharge hose until vibration is eliminated or reduced to a minimum. Replace the stem cap tightly. **NOTE:** It may take a couple of tries to acquire a knack for finding the lowest point of vibration. *Remember*, "too much air" in the airdome is as bad as "too little air."

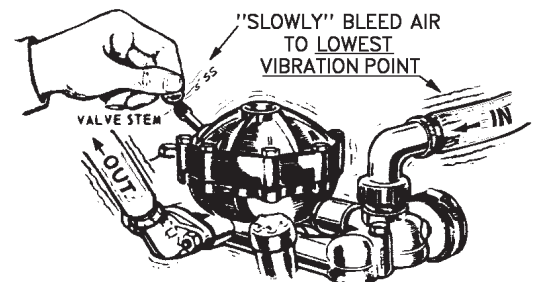
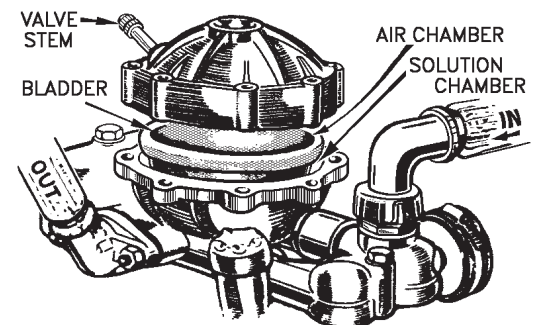

PAK-BLAST-100

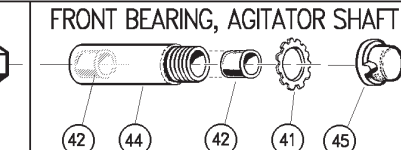
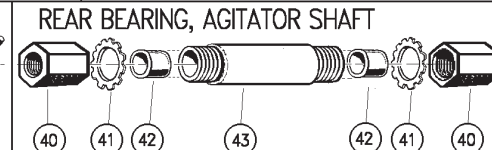
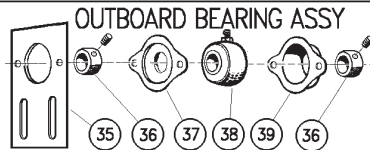
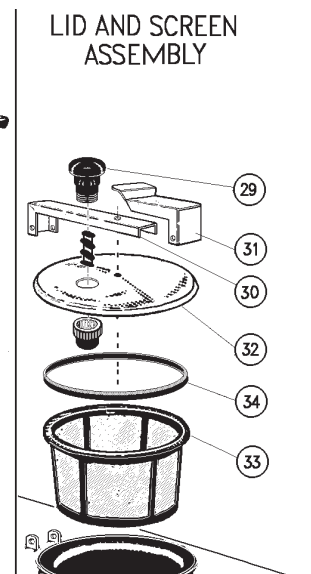
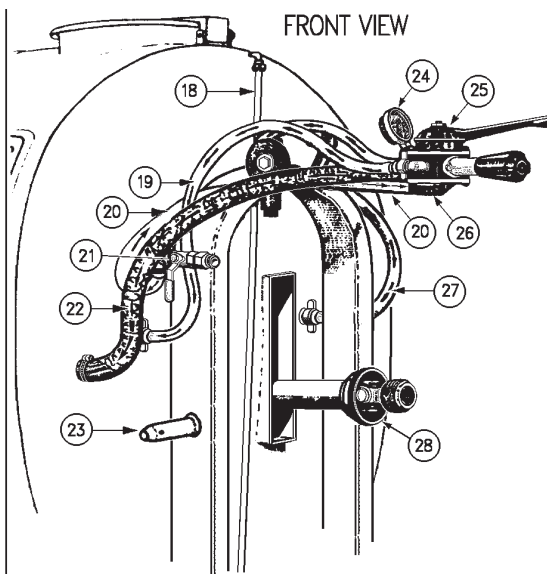
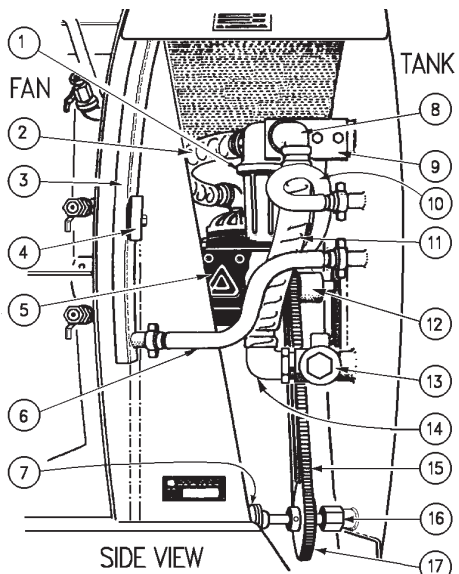

Item	Part Number	Description	Qty	Item	Part Number	Description	Qty
1		See Line Strainer Parts Page		24		Pressure Gauge, Glycerin Filled	1
2		Hose, Clear 1-1/4" - 10"	1	25	170 206	Control Valve	1
3		Manifold, Boom (Specify Right/Left)	2	26	PMB-MTA-B	Mount, Control Valve	1
4		Clamp, Boom	4	27		Hose, Left Manifold 1/2"x 48"	1
5		Pump, Diaphragm	1	28	DL303	Drive line, 36" (no bell impl. end) SEE PAGE 11	1
6		Hose, Boom 1/2"x 15"	1	29	L-V-ASS	Vent Assembly, Tank Lid	1
7		Bearing, Outboard	1	30	LL-6	Latch, Over-Center	1
8		Barb, Hose AR 1-1/4"	1	31	LH-16.5	Hinge, Over-Center Latch	1
9	KB133125	Hanger, Strainer	1	32	Lid-16.5SS	Lid, Stainless Steel	1
10		Hose, Pressure 1/2" x 16"	1	33	STR-SS-15.75	Strainer, Stainless Steel & Plastic	1
11		Hose, Clear 1-1/4"x 12"	1	34		Lid Splash Seal (fits lip of lid strainer)	1
12		Coupler w/Pulley, Pump	1	35	KB202	Bracket, Outboard Flange	1
13	SW-GATE1-1/4B	Valve, Swing Gate	1	36		Collar, 5/8" Lock	2
14		Barb, Hose 1/4"x 1/4"NPT90	1	37		Flange, Flat	1
15	4L470	V-Belt	1	38		Outboard 5/8" Ball Bushing, Bronze	1
16	PMB-AG-SH-	Shaft, Agitator(GiveLgth)(Brgs.below)	1	39		Flange (Deep)	1
17		Pulley, Agitator 5/8"x 6"	1	40		Packing Gland, 3/4" w/packing	2
18	SG 1/2"x 38"	Sight Gauge, Clear Plastic	1	41		Lock Ring, 3/4" Threaded	2
19		Hose, Right Manifold 1/2"x 28"	1	42		Bushing, Bronze	4
20		Hose, Pressure (IN) Line 1/2"x 28"	1	43		Body, 3/4" Rear	1
21		Valve, Gun Hose & "T"	1	44		Body, 3/4" Front	1
22		Hose, Clear Return 1"x 36"	1	45		Cap, 3/4"	1
23	Cat. No.1	Mount Pin Cat. No.1	2				

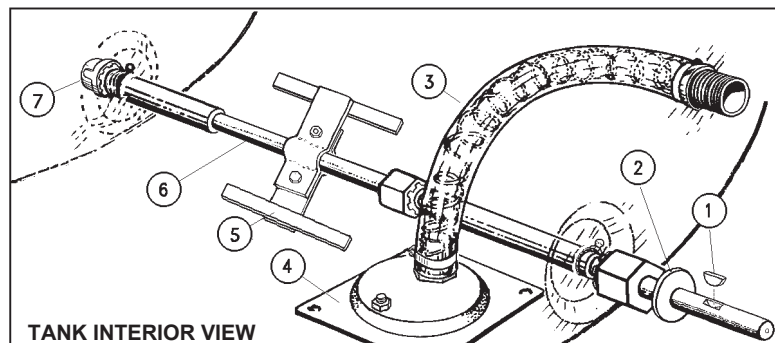

Item	Part No.	Description	Req.
1	3/16x7/8	Key, Woodruff 3/16x7/8	1
2	PKTW-1	Washer, White Thrust	1
3		Hose, Armovin (specify lgth)	1
	#16 SS	Worm Clamp, #16 SS	2
4	PK31SQ	Funnel, Tank Suction	1
	NYHFC125100	Hose Barb, 1"HB x 1-1/4"MGHT	1
	PK31SQBN	Back Nut, Arag 1-1/4"	2
5	PK23P	Paddle Half, Mixing	2
6	PMB-AG-SH-	Shaft, 3/4" Agitator (specify lgth)	1
7		Cap, 3/4"	1

**GEARBOX & FAN ASSEMBLIES**

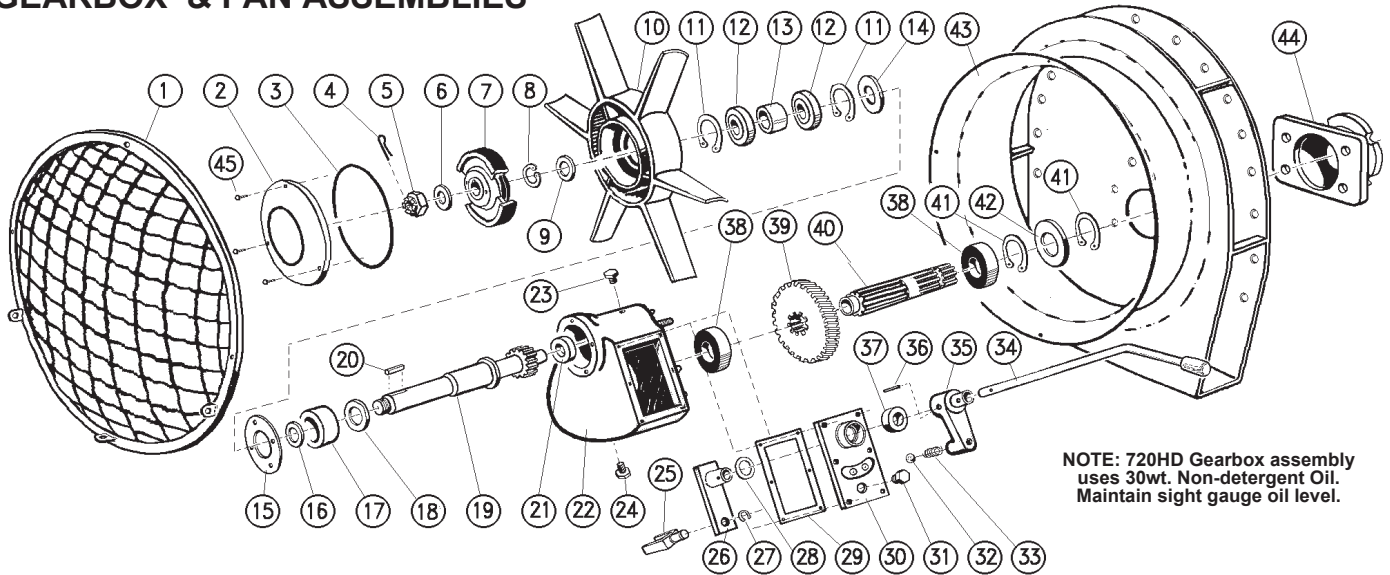

**NOTE: 720HD Gearbox assembly uses 30wt. Non-detergent Oil. Maintain sight gauge oil level.**

Item	Part No.	Description	Req	Item	Part No.	Description	Req
1.		Fan Grill, 24"	1	22.		Housing, Heavy-Duty Gearbox	1
		Fan Grill, 28"		23.		Cap, Oil Fill	1
2.		Cover, Clutch	1	24.		Plug, Oil Drain	1
3.		O-Ring, 5.925 I.D. x .070 for 24" & 28" 6-Bl.	1	25.		Fork, Shifting	1
		O-Ring, 11-7/16" I.D. x .070 for 28"/8 Fixed	1	26.		Guide, Shifting Fork	1
		O-Ring, 10-7/16" I.D. x .070 for 28/8 Vari-Pitch	1	27.		Snap Ring, (5100-66, Shifting Fork	1
4.		Pin, Cotter 5x40	1	28.		Washer	1
5.		Nut	1	29.		Gasket, Cover Plate	1
6.		Washer	1	30.		Cover Plate	1
7.		Clutch, Spring	1	31.		Plug, Sight Gauge Oil Level	1
8.	5100-125	Snap Ring, 5100-125	1	32.		Ball, Shifting Lever 19/32"	1
9.		Spacer	1	33.		Spring, Shifting Lever	1
10.	MF24	Fan, 24" 6-Blade (Fixed Pitch)	1	34.		Shift Arm, 24" Fan (w/Stabilizer Brkt&bolt)	1
	MF26	Fan, 28" 6-Blade (Fixed Pitch)				Shift Arm, 28" Fan "dogleg" (w/Stabil. Brkt&bolt)	
	MF286	Fan, 28" 8-Blade (Fixed Pitch)		35.		Shifting Lever W/6mm Bolt, Nut & Washer	1
	MF288	Fan, 28" 8-Blade (Variable Pitch)		36.		Pin, Shifting Arm 6 x 40	1
11.	N5000-231	Snap Ring, N5000-231	2	37.	7000	Seal, Cover Plate Shifting Lever 30 x 18 x 7	1
12.	6007ZZ	Bearing, 6007ZZ	2	38.	6207	Bearing, Heavy-Duty (6207)	2
13.		Spacer	1	39.		Gear (Heavy-Duty)	1
14.	15845	Seal, 62 x 40 x 10 (15845)	1	40.		Shaft, Splined (Heavy-Duty)	1
15.		Follower	1	41.	5100-137	Snap Ring, 5100-137	2
16.		Seal, 40 x 62 x 10	1	42.	13980	Seal, 35 x 72 x 8 (13980)	1
17.	32208	Bearing, Heavy-Duty (32208)	1	43.		24" Fan Housing & Frame	1
18.		Spacer	1			28" Fan Housing & Frame	
19.		Shaft & Pinion Gear (Heavy-Duty)	1	44.	KBIN117	Adaptor, Pump/gearbox (welds to fan housing)	1
20.		Key, 8 x 7 x 40 Bar	1	45.	MF6620	Socket Hd Cap Screw 6mm x 20mm (24" & 28" 6bl.)	3
21.	30305	Bearing, (Heavy-Duty)	1		MF6825	Socket Hd Cap Screw 6mm x 20mm (28" 8blade)	3

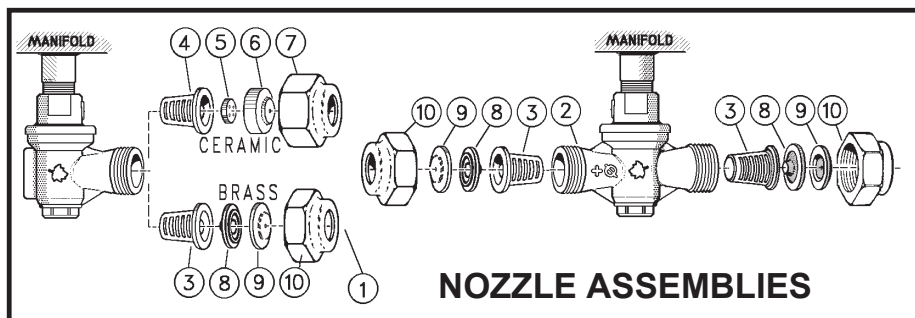

**NOZZLE ASSEMBLIES**

Item	Part No.	Description
1	BR1	Rollover Valve, Single Noz. Body
2	BR2	Rollover Valve, Dbl. Noz. Body
3	4514BR	Strainer, TeeJet Slotted Brass
4	4514PL	Strainer, TeeJet Slotted Plastic
5	#45 Ceramic	Core, TeeJet Ceramic
6	D-5 Ceramic	Disc, TeeJet Ceramic
7	20230	Cap, TeeJet Brass
8	#45	Core, TeeJet Brass
9	D-5	Disc, TeeJet Brass
10	1325	Cap, TeeJet Brass

To expedite an order and assure receiving correct part(s), include your Pak-Blast Serial Number, fan style, and fan size



- a right manifold line
- b pump pressure supply line
- c left manifold line
- d dump- tank return line
- e handgun valve
- f tank return/mix valve this valve
- g tank return/mix line

100 gallon unit with trellis fan housing shown, left.

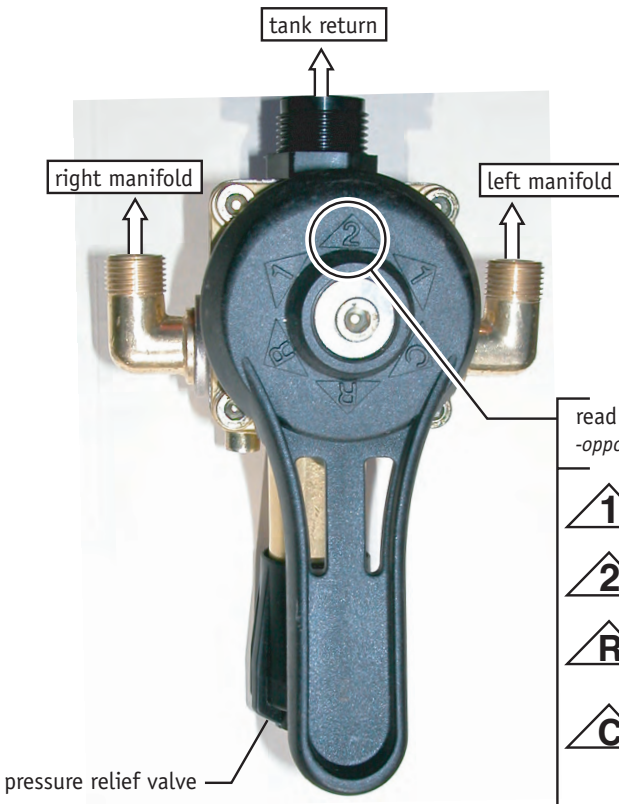
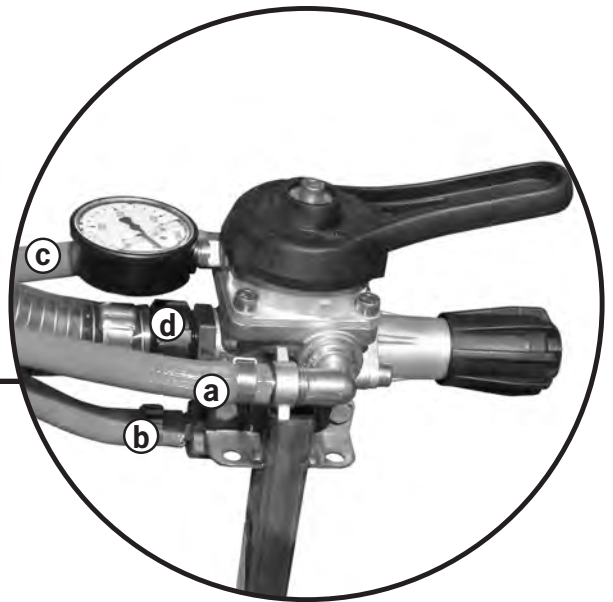

read valve function indicator here.  
-opposite pressure relief valve.

- 1** Spray one side only: swing handle to the side you want to spray.
- 2** Spray both sides.
- R** Tank recirculate. Spray manifolds OFF.  
Tank return bypasses pressure relief valve.
- C** Tank return controlled by pressure relief valve.  
Spray manifolds OFF.  
Use this function to control handgun pressure.

# BR170 selector valve with pressure regulator

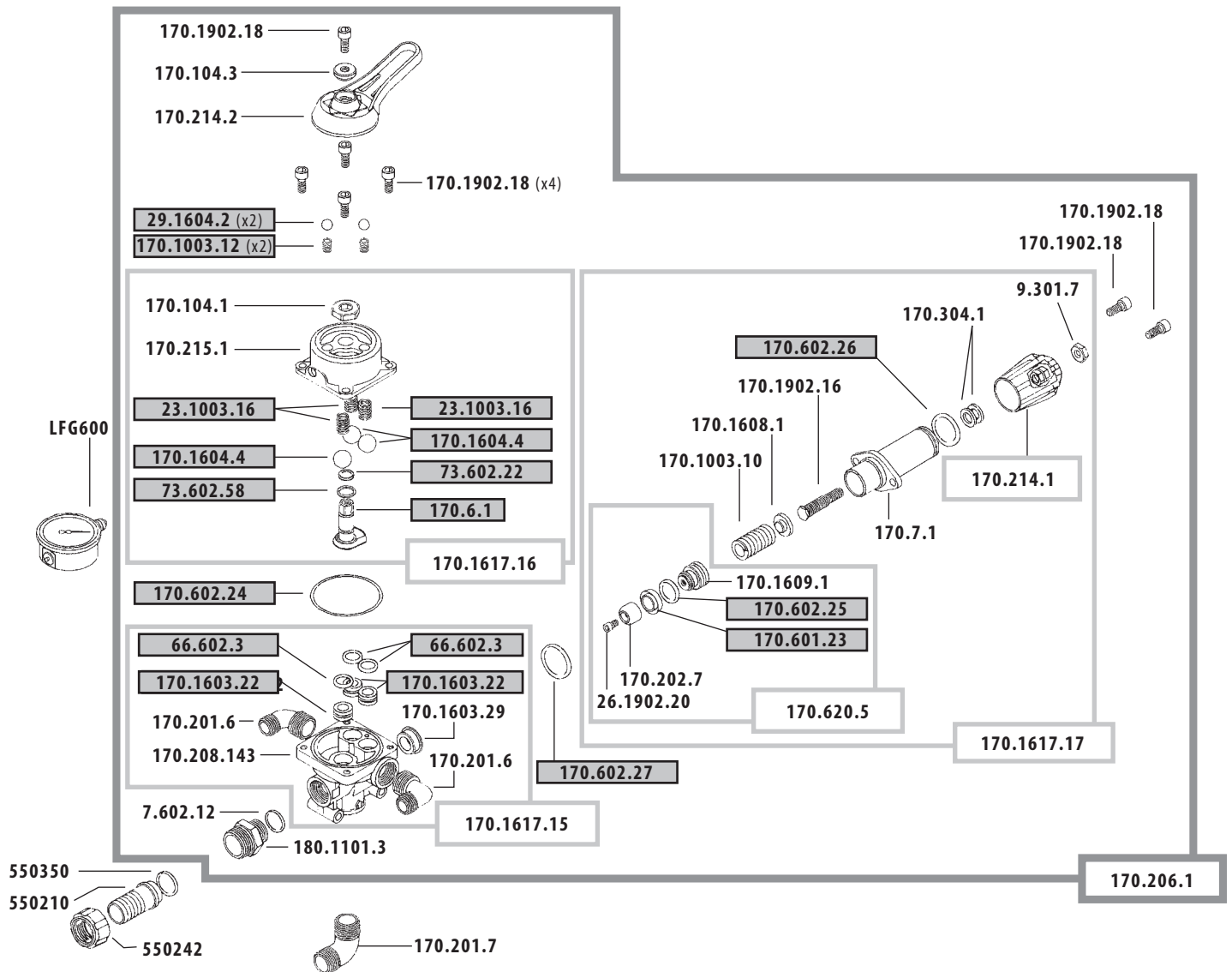

**PART NUMBER**

individual components

subassembly order number

**PART NUMBER**

basic assembly order number

**PART NUMBER**

**PART NUMBER**

component included in a parts kit  
parts kits listed, right

## AVAILABLE PARTS KITS

170.302.30 parts kit for 170.206.8

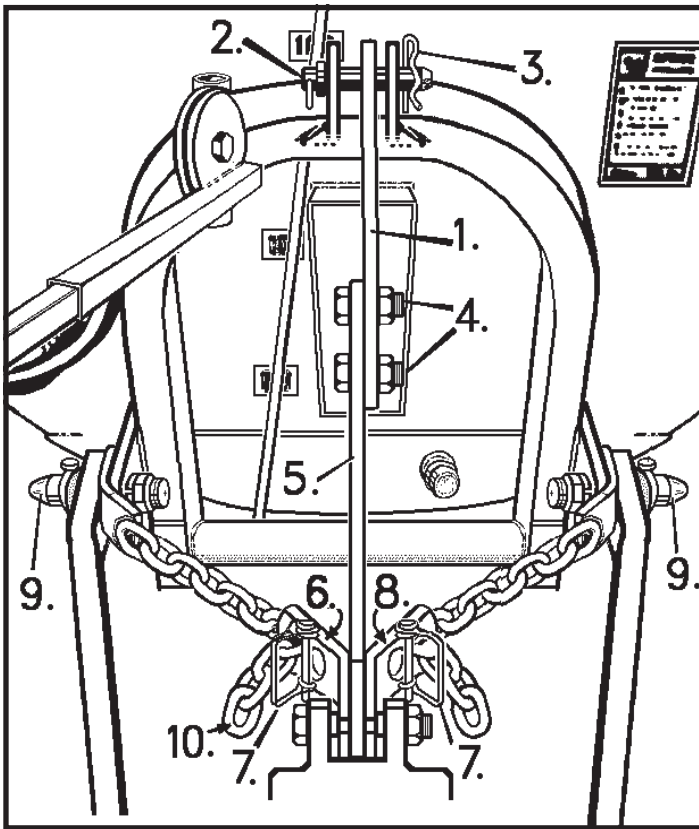

ITEM	PART NO.	MOUNTING GREENWARE	REQ
1	KBIN4511	TOP-LINK, EQUIPMENT HALF	1
2	0750500HP	HITCH PIN, 3/4"X 5" LONG	1
3	CHP6	HAIR PIN, .177" X 3-11/16"	1
4		NUT & BOLT, 3/4"X 2"NC TOP-LINK	2
5	KBIN4512	TOP-LINK, TRACTOR HALF	1
6	HS42R	EYELET BRACKET, ANTI-SAG CHAIN RIGHT	1
7	0310275SNAP	SNAPPER PIN, 5/16" X 2-3/4" OAL	2
8	HS42L	EYELET BRACKET, ANTI-SAG CHAIN LEFT	1
9	CVH41-17-1	PIN, CATEGORY NO.1 W/CAT.1 THREADS)	2
10	HS43CH1	SWAY BRACE CHAIN FOR CAT.1 OR 2 PIN	2

**LID ADJUSTMENT:** After a period of use, the lid latch may lose some of its tautness. Remedy this by widening the space between the lid and the hinge: adjust the nut on the lid bolt until the desired latch tautness is achieved.

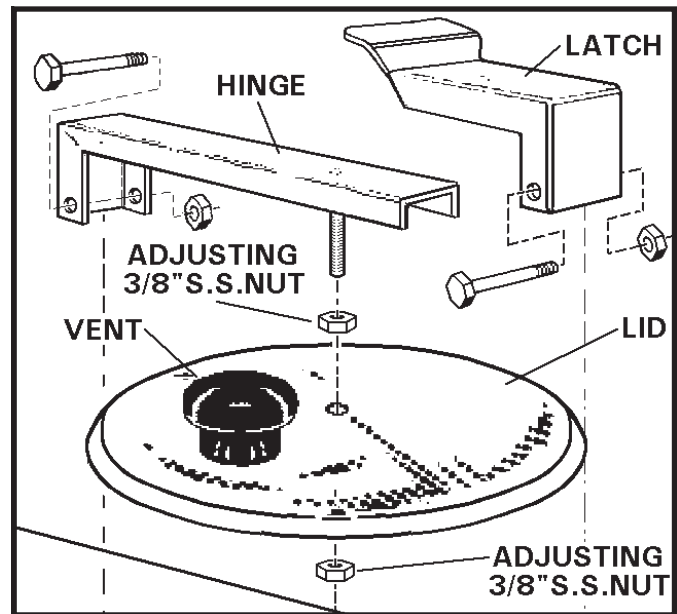

**DL303 PTO DRIVELINE 1-3/8" 6-SPLINE LOCK AT BOTH ENDS**

**DL 303**

36" OAL PTO DRIVELINE  
 Y301: 1-3/8" 6-Spl. Q.D. (both ends)  
 1-5/16"-20 Rolled Spl., Telescope  
 (Modified Shield)  
 CROSS KIT: DN/35RW  
 Used on 100 Gallon Pak-Blast

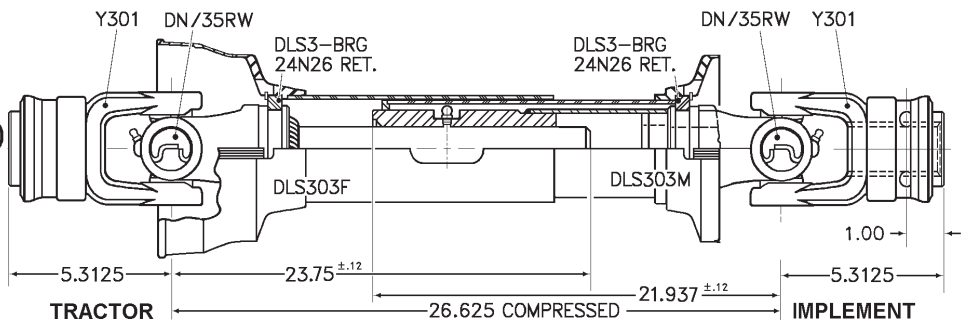



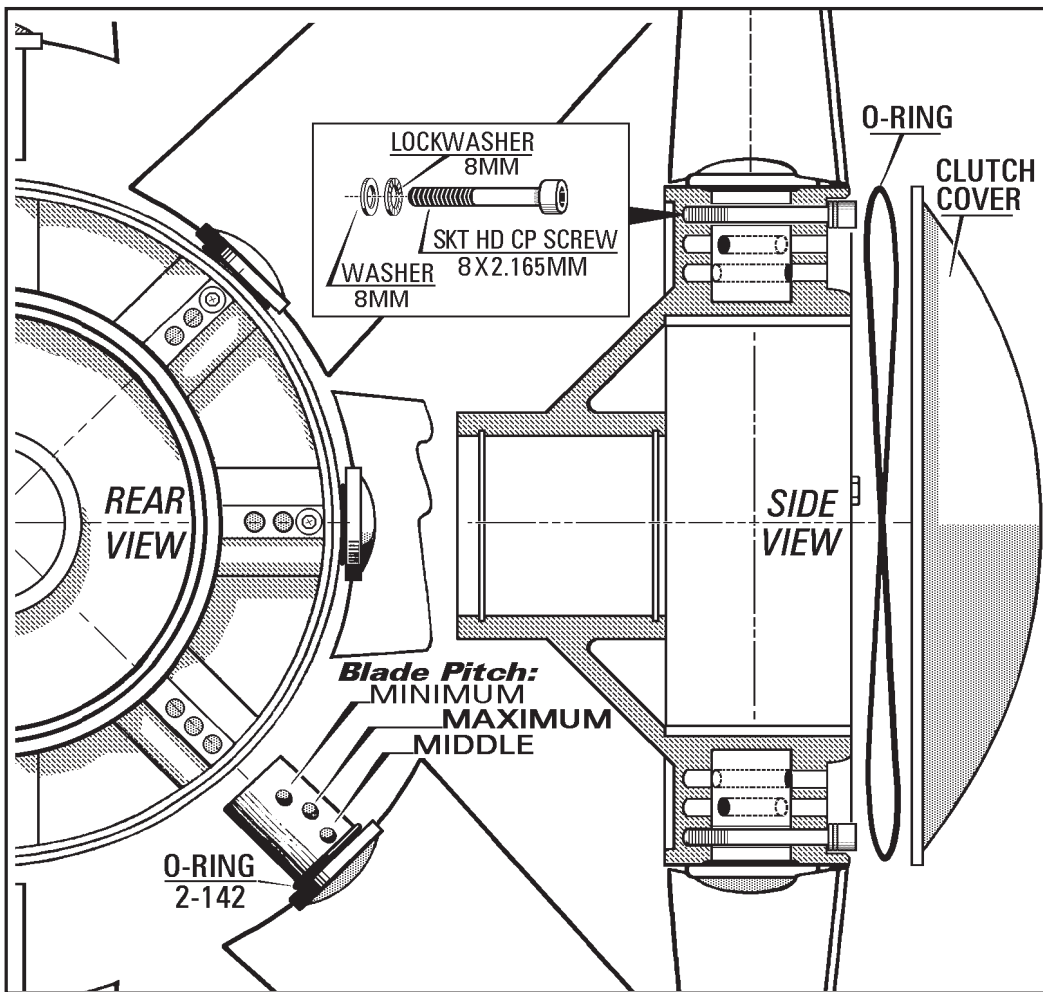

## 28" FAN W/ADJUSTABLE

### BLADE PITCH

(CUT-A-WAY VIEW)  
THREE POSITION  
BLADE PITCH  
ADJUSTING  
INSTRUCTIONS

- A.** Remove fan Clutch Cover (held by three 5mm socket head screws).
- B.** Remove 6mm socket head cap screw from each blade.
- C.** Reposition blades at desired "identical" pitch. Install (Finger tight) each 6mm socket head screw in its respective blade pitch hole. Double check blades to assure pitch settings are identical. Firmly tighten cap screws.
- D.** Replace clutch cover. Be certain large diameter O-ring is properly placed.

# IMPORTANT

## "NOZZLES WILL WEAR!!!"

This is especially true when using wettable powders. As the nozzles wear (enlarging orifice diameter), the application rate will increase even though pressure and speed are accurately known and held constant. A periodic G.P.A Accuracy Check ( Step#5 above) in accordance with use, is warranted to maintain "Gallons Per Acre" accuracy.

**CHANGING TRACTORS:** The sprayer has to be recalibrated.

#### TRACTOR TIRES

If, in changing tractor tires, tire diameter is changed, the sprayer has to be recalibrated.

#### LEGEND:

**G.P.A.** = Gallons Per Acre.

**G.P.M.** = Gallons Per Minute.

**V.P.N.** = Volume Per Nozzle.

**TREE MIDDLES** = Distance Between Rows of Trees.

**TREE SETTINGS** = Distance Between Trees in a Row.

## 126 Line Strainer Assembly

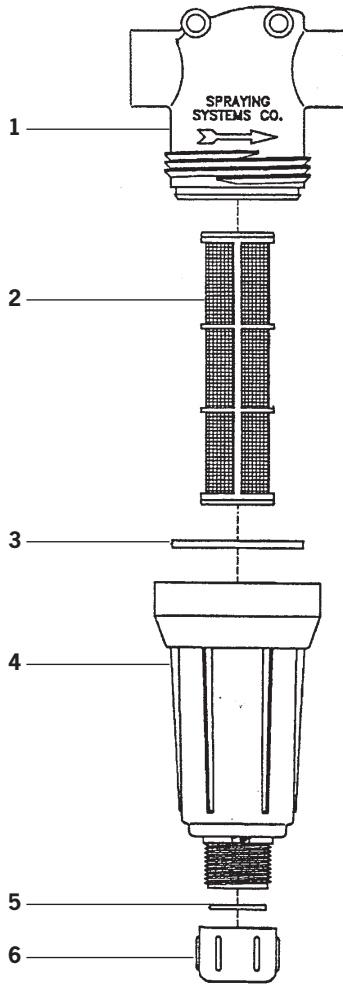

No.	3/4" inlet	1" inlet	1-1/4" inlet	1-1/2" inlet	Description	Qty
-	126ML-3- mesh #	126ML-4- mesh #	126ML-5- mesh #	126ML-6- mesh #	complete strainer- include screen mesh	-
1	50492-3/4-PP	50492-1-PP	63065-1-1/4PP	63066-1-1/2PP	strainer head	1
2	16903-1-SSPP		15941-1-SSPP		16 mesh screen, gray	1
	16903-3-SSPP		15941-2-SSPP		30 mesh screen, yellow	
	16903-4-SSPP		15941-3-SSPP		50 mesh screen, red	
	16903-5-SSPP		15941-4-SSPP		80 mesh screen, blue	
	16903-6-SSPP		15941-5-SSPP		100 mesh screen, green	
3	50494-EPR		48656-EPR		large strainer gasket	1
4	50493-PP		48654-PP		strainer bowl, poly	1
5	63150-EPR				small strainer gasket	1
6	48655-PP				cap	1

# PUMP OPERATION



## Maintain proper oil level

The crankcase oil serves two important functions. The oil lubricates all moving parts in the pump *and* affects the hydraulic action for optimal pump capacity. The pump diaphragms are supported by the crankcase oil during each pressure upstroke of the piston: to assure maximum performance of your pump and protect your pump diaphragms **maintain the oil level** marked on the transparent filler spout.

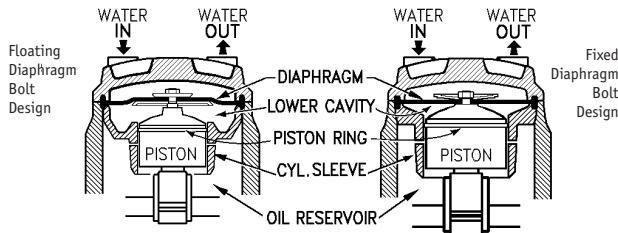

## How the AR diaphragm pump works

Each *downstroke* of the piston/diaphragm assembly draws spray material into the upper head cavity. Simultaneously, crankcase oil from the lower head cavity is expelled as the cycling piston ring passes a vent in the cylinder sleeve, *see above illustration*. Each upstroke of the piston injects a measured amount of oil back into the lower head cavity, expanding the diaphragm as the piston cycle tops-out and expelling the spray material from the upper chamber. **Low oil level lowers performance.**

For optimal hydraulic diaphragm actuation, piston assembly lubrication, diaphragm membrane support: check the oil level frequently- the transparent oil-fill makes level checks easy. Maintain the indicated level.

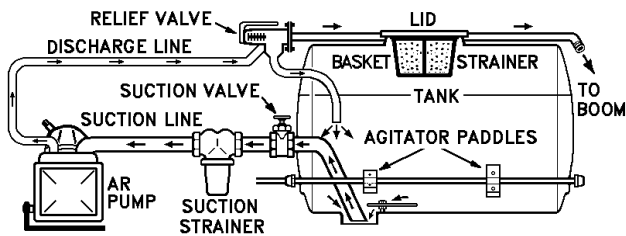

## Don't starve the suction

The pump will not suffer if run dry when the tank is empty. A **clogged suction strainer** or **closed suction valve**, however, will **starve the pump** and cause premature diaphragm failure.

**When mixing powders**, avoid clogging the suction strainer by *sluicing* heavy concentrations of wettable powders through the lid basket into an already half-filled tank. Agitator paddles will mix the powder into solution, preventing material deposits at the bottom of the tank which plug the suction strainer.

**The suction valve** is provided to shut off flow from the tank: for emergency plumbing repair or for strainer cleaning. **To prevent possible pump damage, SHUTDOWN SYSTEM before closing the suction valve.**

How clean is your water source? You may need to clean your suction strainer before each tank refill.

## Do not over-speed your pump

Refer to the performance chart for your specific pump to find the **maximum operating speed**. Your pump is designed to operate at or below this speed. Over-speeding will cause valves to prematurely fail and could cause other internal damage.

## Before pump operation

Check tightness of suction line fittings and strainer cap. Follow airdome pressurizing instructions, below.

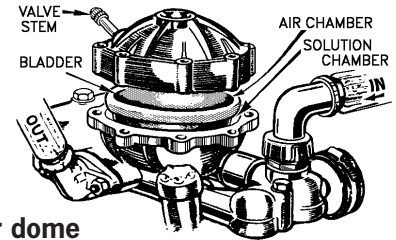

## Pressurizing the air dome

Piston and piston-like pumps (diaphragm pumps) will have pulsation vibration, *water hammer*, because of the rapid change in piston direction. The **air dome** pulsation dampener reduces vibration by providing a cushion of air to bump against: *inflate or deflate this cushion to reduce vibration*. The AR airdome uses a rubber bladder to separate the air cushion from the spray material. The bladder eliminates water-logging problems common in static-air type dampeners.

**If you have a pressure gauge** the basic rule is to charge the air dome to 10% of the system working pressure: for a handgun pressure of 100psi, we recommend an air dome pressure of 10psi. Always shut down pump before adding air to the airdome with either a compressor or manual pump. The air cushion is small, making pressure checks challenging. Take care applying the pressure gauge evenly on the air valve to prevent air from leaking out of the air dome. It is not uncommon to lose 5-10 psi checking the pressure.

**If you do not have a pressure gauge** charge the air dome *with the pump shut down* to 70-80 psi: sufficient for 700 psi working pressure. Start up the pump (expect pump vibration) and adjust the relief valve to your desired working pressure. Slowly bleed off air dome pressure while watching the vibration of the pump discharge hose. Continue bleeding until vibration is eliminated or minimized. Replace stem cap tightly. *It may take a couple attempts to get the feel for minimum vibration.*

*Too much air in the air dome is as bad as too little.*

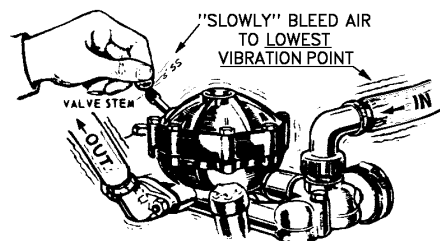

# PUMP MAINTENANCE



**HANDLE AGRICULTURAL CHEMICALS WITH CARE**

**USE THE PERSONAL PROTECTIVE EQUIPMENT  
RECOMMENDED BY THE CHEMICAL MANUFACTURER  
WHEN MAINTAINING SPRAY EQUIPMENT!**

## After each use

Run pump for five minutes with *clean* water. These few minutes of flushing are well spent: extend diaphragm life, minimize chemical buildup throughout your spray system.

## After every 200 hours AND at season's end

Inspect diaphragms for wear marks, swelling, and stretching. See the *diaphragm replacement instructions, below*. Check valves for spring fatigue and seat wear. Change the oil- the crankcase oil capacity is in your pump manual. Use a **30W non-detergent oil**. Rotate the pump shaft by hand while filling to evacuate air pockets. With pump level, the crankcase is full when oil level reaches the indicator on the transparent fill neck. Run pump for 10 minutes under **no load** conditions to evacuate remaining air pockets. Recheck oil level. During first field run, **check oil color closely**. If it should turn milky, the diaphragms were not correctly seated.

## Winter storage

Run pump for five minutes with *clean* water. Then, with suction and discharge valves *open* and the tank empty, run pump five minutes to ensure complete drainage of pump heads and lines. A gallon of anti-freeze recirculated through the system and left in place after shut down completes your winterizing. Allow anti-freeze to replace any possible water in hoses and booms. If a handgun is in the system, run anti-freeze through the hose and handgun, returning the spray into the tank through the lid. Two gallons of anti-freeze may be required to winterize systems with handgun lines.

## Replacing suction diaphragms

**Drain the crankcase.** Slowly turn pump shaft by hand until all oil is drained. Older AR30/50 pumps without a drain plug require a head and diaphragm to be removed to empty oil.

**Remove the manifold:** take care not to lose or damage input/output port o-rings.

### Head removal- repair one head at a time.

Remove fasteners securing head to body- some pumps use bolts (*fig. A*) others have nuts on mount studs (*fig. B*). You may need to lightly pry the head cover with a flathead screwdriver to loosen.

**Remove the old diaphragm.** Top out the piston/diaphragm assembly by turning the pump shaft. Remove the diaphragm retaining nut (*fig. A*) If the nut holds and the retaining bolt loosens from the piston head, this creates no problem. (*Some bolts have a hole (fig. C) to insert a 8" pin punch and hold bolt when removing nut & washer.*) Using a flathead screwdriver (*fig. B*) pry the diaphragm from its seat.

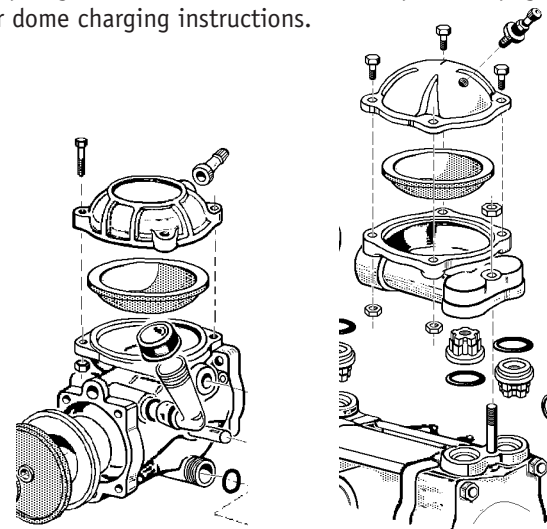
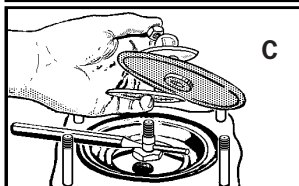
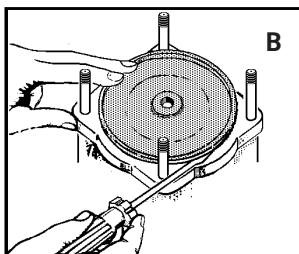
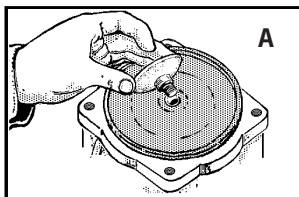

AR202/19 style

AR30/50 style



Diaphragm WITH support washer    Diaphragm WITHOUT support washer

**Install the new diaphragm.** If your model uses a diaphragm support washer (see *washer installation diagram*, above) be certain it is installed as illustrated. Pour 2 Tbsp **30W non-detergent oil** into lower diaphragm cavity. Tap new diaphragm into seat groove with the handle of a screwdriver. Reassemble retaining washer and nut as illustrated and re-assemble head and manifold.

**Fill the crankcase with oil.** The crankcase oil capacity is in your pump manual. Use a **30W non-detergent oil**. Rotate the pump shaft by hand while filling to evacuate air pockets. With pump level, the crankcase is full when oil level reaches the indicator on the transparent fill neck. Run pump for 10 minutes under **no load** conditions to evacuate remaining air pockets. Recheck oil level. During first field run, **check oil color closely**. If it should turn milky, the diaphragms were not correctly seated.

# TROUBLESHOOTING

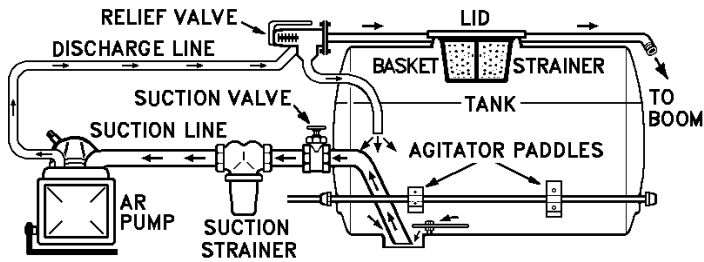

The AR diaphragm pump delivers volume determined by pump speed. Set pressure with your adjustable relief valve.

Problem	Source	Fix
No pressure	Plugged strainer	Clean screen- see <i>suction care</i> on pump operation page.
Very little pressure	Suction hose obstruction	Clear obstruction
	Collapsed suction hose outside or inside tank	Replace collapsed hose
Pressure drops below working range when relief valve is open to spray applicator	Pump sucking air	Hoses and unions should be tightly fitting and have no holes
	Nozzle volume greater than pump capacity	Adjust relief valve Reduce nozzle orifice size Reduce number of nozzles in use
	Excessive tank foam	Refill tank if foaming because of low volume Move agitator paddle if too close to suction
	Pressure relief valve stuck or worn	Check relief valve for wear- repair or replace
	Pump inlet/outlet check valve worn	Replace check valve(s)
Pressure gauge fluctuates wildly	Air dome pressure too low or high	See <i>pressurizing instructions</i> on pump operation page
	Pump sucking air	Hoses and unions should be tightly fitting and have no holes
	Faulty suction strainer	Check strainer and connections for suction leaks
	Air in pump cavity	Run pump with open discharge to completely evacuate air
No pump suction	Check valve seating improperly	Examine and clean all check valve seats in the pump
Milky pump oil	Diaphragm rupture	Check diaphragms and replace where necessary
Transparent filler spout overflows		See <i>diaphragm replacement</i> on pump maintenance page
Output drops	Low oil level	Add oil to fill level indicated on fill neck
Pump noisy		Use 30W non-detergent oil
Excessive pulsation	Air dome pressure too low or high	See <i>pressurizing instructions</i> on pump operation page



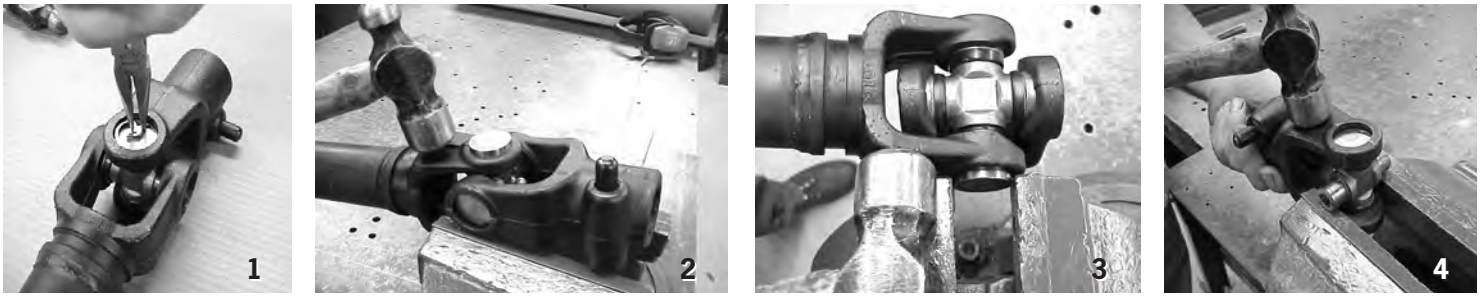

## universal joint disassembly

Remove all (4) snap rings in cross assembly **1**.

Position joint in loose vice **2**. Strike top arm of unsupported yoke to drive the top cup up. Repeat on the opposite side.

Grip loosened cup in vice **3** and strike yoke arm to drive yoke off cup. Repeat on opposite cup.

Support cross in loose vice **4** and strike yoke arm to drive the top cup up. Repeat on opposite side.

Repeat step **3** to remove the remaining two cups.

*Note:* Yoke arms must be true. If a yoke arm is *sprung* by striking with excessive force, the cross will bind in operation.

*True yoke test-* slide a machined rod (a few thousandths under cup diameter) through the yoke arms. The yoke must be replaced if the yoke won't slide completely onto the rod.

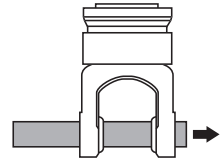

55 series rod diameter 1.530"

35 series rod diameter 1.247



## universal joint reassembly

Clean bearings **1** before assembling cross. Cups should be free from dirt- and be certain the seal from the previous cross does not remain in the cup. Smear grease in the clean bearing.

Make certain all needle bearings are seated properly.

Clean bearing seat in yoke arms. Check for burrs (in new yokes also). File out any burrs: bearing seat should be smooth and clean.

Yoke arms must be true (see *true yoke test*, above).

If a yoke arm is *sprung* by striking with excessive force, the cross will bind in operation.

Where a *spacer* is required, select a diameter that evenly distributes force around the outer edge of the bearing cup. Choosing a spacer of insufficient diameter or using no spacer at all will drive the bearings unevenly and cause the joint to bind in operation.

You should assemble the joint in a clean area.

Insert the cup and cross **2** and drive in with a spacer.

Insert snap ring **3**.

Insert second cup **4** and hold cross in place to drive on cup. Drive cup down with spacer and insert snap ring.

To loosen cross, strike yoke arm **5** and check cross for free rotation.

Position second yoke on cross **6** and repeat steps **2** to **5**.

# LIMITED WARRANTY



Rears Manufacturing Company Incorporated, hereafter referred to as Rears, makes every effort to assure that its products meet high quality and durability standards subject to the provisions hereinafter set forth. Rears does hereby warrant to the original purchaser of each product manufactured by Rears for a period of ninety (90) days from the date of purchase or five hundred (500) hours of operation, which-ever occurs first, that such product will be free from defects in material and workmanship under normal use with normal maintenance service. This warranty does not cover component parts of products manu-factured by Rears when such component parts are subject to a manufacturer's warranty. In addition, this warranty does not cover pressure gauges.

THE EXCLUSIVE REMEDY FOR ANY DEFECTS COVERED BY THIS WARRANTY SHALL BE THE OBLIGATION OF REARS TO REPAIR OR REPLACE ANY PARTS OF SAID PRODUCTS WHICH SHALL, WITHIN NINETY (90) DAYS FROM THE DATE OF PURCHASE OR FIVE HUNDRED (500) HOURS OF OPERATION, WHICHEVER OCCURS FIRST, BE DETERMINED TO THE SATISFACTION OF REARS UPON REARS' EXAMINATION, TO HAVE BEEN THUS DEFECTIVE.

In order to take advantage of this limited warranty the defective product must be returned for exami-nation, freight pre-paid, to Rears or an authorized dealer designated by Rears. Proof of purchase date and explanation of the defect must accompany the returned product.

REARS MAKES NO EXPRESSED OR IMPLIED WARRANTIES OF ANY KIND, INCLUDING THE IMPLIED WAR-RANTIES OF MERCHANTABILITY AND OF FITNESS FOR ANY PARTICULAR PURPOSE OTHER THAN STATED HEREIN.

The limited warranty contained herein shall not apply to any product if it shall have been repaired or altered by personnel not authorized by Rears or if the product shall have been subject to misuse, negligence or accident.

THE REMEDIES PROVIDED HEREIN ARE THE EXCLUSIVE REMEDIES TO THE PURCHASER AND REARS SHALL NOT BE LIABLE TO THE PURCHASER OR ANY OTHER PARTY FOR INCIDENTAL, CONSEQUENTIAL OR SPECIAL DAMAGES OR ANY CAUSE, LOSS, ACTION, CLAIM OR DAMAGE WHATSOEVER FOR INJURY TO PERSON OR PROPERTY OR ANY CONSEQUENTIAL ECONOMIC OR INCIDENTAL LOSS RESULTING FROM ANY DEFECT IN MATERIALS OR WORKMANSHIP OF THE PRODUCT SOLD.

Rears will assign to the original purchaser upon request all warranties on component parts if permitted by the manufacturer of such component parts.

**Purchaser Name**

Purchase Date

Address

City

State/Zip

Model

Serial Number

**Dealer Name**

Sales person

Phone

Address

City

State/Zip