



| ICAO

Doc 10069, CAEP/10

TENTH MEETING

Montréal, 1–12 February 2016

COMMITTEE ON AVIATION ENVIRONMENTAL PROTECTION

REPORT

Approved by the Committee on Aviation Environmental Protection and published by decision of the Council.

The views expressed in this report should be taken as advice of a body of experts to the Council but not as representing the views of the Organization.

The Supplement to the report indicates the action taken on the report by the Council.



| ICAO

Doc 10069, CAEP/10

TENTH MEETING

Montréal, 1–12 February 2016

COMMITTEE ON AVIATION ENVIRONMENTAL PROTECTION

REPORT

Approved by the Committee on Aviation Environmental Protection and published by decision of the Council.

The views expressed in this report should be taken as advice of a body of experts to the Council but not as representing the views of the Organization.

The Supplement to the report indicates the action taken on the report by the Council.

Published in separate English, Arabic, Chinese, French, Russian
and Spanish editions by the
INTERNATIONAL CIVIL AVIATION ORGANIZATION
999 Robert-Bourassa Boulevard, Montréal, Quebec, Canada H3C 5H7

For ordering information and for a complete listing of sales agents
and booksellers, please go to the ICAO website at www.icao.int.

Doc 10069, *Committee on Aviation Environmental Protection, Tenth Meeting*

Order Number: 10069

ISBN 978-92-9258-064-3

© ICAO 2016

All rights reserved. No part of this publication may be reproduced, stored in a
retrieval system or transmitted in any form or by any means, without prior
permission in writing from the International Civil Aviation Organization.

INTERNATIONAL CIVIL AVIATION ORGANIZATION
TENTH MEETING OF THE
COMMITTEE ON AVIATION ENVIRONMENTAL PROTECTION (CAEP)

Montréal, 1 to 12 February 2016

SUPPLEMENT NO. 1

1. The Council, at the Thirteenth meeting of its 208th Session on 10 June 2016, took action on the recommendations of the tenth meeting of the Committee on Aviation Environmental Protection (CAEP/10), as set forth hereunder.

2. **RECOMMENDATIONS FOR AMENDMENT OF STANDARDS AND RECOMMENDED PRACTICES AND PROCEDURES (RSPP)**

- 2.1 Recommendation 3/1, page 3-4
Recommendation 4/1, page 4-4
Recommendation 5/1, page 5-9
Recommendation 6/1, page 6-3

2.2 The Council noted that the Air Navigation Commission had made a preliminary review of the above recommendations and agreed that they should be referred to Member States and international organizations. Following receipt of comments, the Commission will conduct a detailed review and will then present its recommendations for action to the Council.

3. **RECOMMENDATIONS OTHER THAN FOR STANDARDS AND RECOMMENDED PRACTICES AND PROCEDURES**

3.1 The Secretary General will arrange for any follow-up action in respect of all approved recommendations as indicated in the action taken hereunder.

Report Reference		Action by Council (C) or Air Navigation Commission (ANC)	Recommendation Title and Action Taken
Recommendation No.	Page No.		
1/1	1-5	C	<p>Endorsement of the global environmental trends assessments</p> <p>Approved the recommendation with amendments and requested the Secretary General to take the necessary action.</p>
2/1	2-4	C	<p>Update to ICAO Doc 9911, <i>Recommended Method for Computing Noise Contours Around Airports</i></p> <p>Approved the recommendation and requested the Secretary General to take the necessary action.</p>
2/2	2-7	C	<p>ICAO Cargo Carbon Emissions Calculator Methodology</p> <p>Approved the recommendation and requested the Secretary General to take the necessary action.</p>
3/1	3-4	ANC	<p>General Amendments to Annex 16 — <i>Environmental Protection, Volume II — Aircraft Engine Emissions</i></p> <p>Approved the recommendation and requested the Secretary General to take the necessary action.</p>
3/2	3-6	C	<p>General Amendments to the <i>Environmental Technical Manual, Volume II — Procedures for the Emissions Certification of Aircraft Engines</i></p> <p>Approved the recommendation and requested the Secretary General to take the necessary action.</p>
4/1	4-4	ANC	<p>Amendments to Annex 16 — <i>Environmental Protection, Volume II — Aircraft Engine Emissions</i>, to introduce the new CAEP/10 nvPM SARPs</p> <p>Approved the recommendation and requested the Secretary General to take the necessary action.</p>

Report Reference		Action by Council (C) or Air Navigation Commission (ANC)	Recommendation Title and Action Taken
Recommendation No.	Page No.		
4/2	4-4	C	<p>Amendments to the <i>Environmental Technical Manual, Volume II — Procedures for the Emissions Certification of Aircraft Engines</i>, associated with the new CAEP/10 nvPM SARPs</p> <p>Approved the recommendation and requested the Secretary General to take the necessary action.</p>
5/1	5-9	ANC	<p>Amendments to Annex 16 — Environmental Protection, Volume III — <i>Aeroplane CO₂ Emissions</i></p> <p>Approved the recommendation and requested the Secretary General to take the necessary action.</p>
5/2	5-9	C	<p>First Edition of the Environmental Technical Manual, Volume III — <i>Procedures for the CO₂ Emissions Certification of Aeroplanes</i></p> <p>Approved the recommendation and requested the Secretary General to take the necessary action.</p>
5/3	5-9	C	<p>Use of the CO₂ Emissions Standard</p> <p>Approved the recommendation and requested the Secretary General to take the necessary action.</p>
6/1	6-3	ANC	<p>Amendments to Annex 16 — Environmental Protection, Volume I — <i>Aircraft Noise</i></p> <p>Approved the recommendation and requested the Secretary General to take the necessary action.</p>

Report Reference		Action by Council (C) or Air Navigation Commission (ANC)	Recommendation Title and Action Taken
Recommendation No.	Page No.		
6/2	6-3	C	<p>Amendments to the Environmental Technical Manual, Volume I — Procedures for the Noise Certification of Aircraft</p> <p>Approved the recommendation and requested the Secretary General to take the necessary action.</p>
7/1	7-3	C	<p>Publication of a Circular on Community Engagement for Aviation Environmental Management</p> <p>Approved the recommendation and requested the Secretary General to take the necessary action.</p>
7/2	7-4	C	<p>Airport Planning Manual, Part 2</p> <p>Approved the recommendation and requested the Secretary General to take the necessary action.</p>
7/3	7-5	C	<p>ASBU Environmental Analysis</p> <p>Approved the recommendation with amendments and requested the Secretary General to take the necessary action.</p>
9/1	9-12	C	<p>Acceptance of Reports of MRV, EUC and Registries as the basis of CAEP future work</p> <p>Approved the recommendation and requested the Secretary General to take the necessary action.</p>
12/1	12-3	C	<p>CAEP/11 work programme</p> <p>Approved the revised work programme.</p>

**REPORT OF THE TENTH MEETING OF THE
COMMITTEE ON AVIATION ENVIRONMENTAL PROTECTION (CAEP) (2016)**

LETTER OF TRANSMITTAL

To: President of the Council

From: Chairman, Committee on Aviation Environmental
Protection (CAEP) (2016)

I have the honour to submit the report of the tenth meeting of the
Committee on Aviation Environmental Protection (CAEP) which
was held in Montréal, Canada, from 1 to 12 February 2016

A handwritten signature in black ink, appearing to be 'Urs Ziegler', written in a cursive style.

Mr. Urs Ziegler
Chairman

Montréal, Canada, 12 February 2016

TABLE OF CONTENTS

	Page
HISTORY OF MEETING	
1. Duration	ii-1
2. Attendance	ii-1
3. Officers and Secretariat	ii-5
4. Agenda of the meeting	ii-6
5. Working arrangements	ii-6
6. Terms of reference of CAEP	ii-6
7. Rules governing CAEP	ii-7
8. CAEP/10 work programme	ii-7
9. Opening remarks by the President of the Council	ii-18
 GENERAL	
1. Membership and Participation in CAEP Activities	iii-1
2. Developments in Other UN Bodies	iii-1
3. Developments in ICAO	iii-4
 REPORTS OF THE MEETING	
Agenda Item 1: Review of the assessments of the present and future impact of aircraft noise and emissions	1-1
Agenda Item 2: Review of models and databases	2-1
Agenda Item 3: Review of technical proposals relating to aircraft engine emissions	3-1
Agenda Item 4: Particulate Matter Standard development	4-1
Agenda Item 5: CO ₂ Standard development	5-1
Agenda Item 6: Review of technical proposals relating to aircraft noise	6-1
Agenda Item 7: Environmental guidance for airports and operations	7-1
Agenda Item 8: Alternative fuels	8-1
Agenda Item 9: Global market-based measure technical analysis: monitoring, reporting, and verification (MRV) and emissions unit criteria (EUC)	9-1
Agenda Item 10: Global market-based measure technical analysis: evaluation of technical proposals	10-1
Agenda Item 11: Review of current science related to aircraft noise and emissions	11-1
Agenda Item 12: Future work	12-1

LIST OF RECOMMENDATIONS¹

			Page
1/1		Endorsement of the global environmental trends assessments	1-5
2/1		Update to ICAO Doc 9911, <i>Recommended Method for Computing Noise Contours Around Airports</i>	2-4
2/2		ICAO Cargo Carbon Emissions Calculator Methodology	2-7
3/1	RSPP	General Amendments to Annex 16 — <i>Environmental Protection, Volume II — Aircraft Engine Emissions</i>	3-4
3/2		General Amendments to the Environmental Technical Manual, Volume II — <i>Procedures for the Emissions Certification of Aircraft Engines</i>	3-6
4/1	RSPP	Amendments to Annex 16 — <i>Environmental Protection, Volume II — Aircraft Engine Emissions</i>, to introduce the new CAEP/10 nvPM SARPs	4-4
4/2		Amendments to the Environmental Technical Manual, Volume II — <i>Procedures for the Emissions Certification of Aircraft Engines</i>, associated with the new CAEP/10 nvPM SARPs	4-4
5/1	RSPP	Amendments to Annex 16 — <i>Environmental Protection, Volume III — Aeroplane CO₂ Emissions</i>	5-9
5/2		First Edition of the Environmental Technical Manual, Volume III — <i>Procedures for the CO₂ Emissions Certification of Aeroplanes</i>	5-9
5/3		Use of the CO₂ Emissions Standard	5-9
6/1	RSPP	Amendments to Annex 16 — <i>Environmental Protection, Volume I — Aircraft Noise</i>	6-3
6/2		Amendments to the Environmental Technical Manual, Volume I — <i>Procedures for the Noise Certification of Aircraft</i>	6-3
7/1		Publication of a Circular on Community Engagement for Aviation Environmental Management	7-3
7/2		Airport Planning Manual, Part 2	7-4
7/3		ASBU Environmental Analysis	7-5
9/1		Acceptance of Reports of MRV, EUC and Registries as the basis of CAEP future work	9-12
12/1		CAEP/11 Work Programme	12-3

¹ Recommendations annotated “RSPP” relate to proposals for amendment of Standards, Recommended Practices and Procedures for Air Navigation Services or guidance material in an Annex.

COMMITTEE ON AVIATION ENVIRONMENTAL PROTECTION (CAEP)

TENTH MEETING

Montréal, Canada, 1 to 12 February 2016

HISTORY OF THE MEETING

1. DURATION

1.1 The tenth meeting of the Committee on Aviation Environmental Protection (CAEP) was opened by the First Vice President of the Council in Montréal, Canada, at 0930 hours on 1 February 2016. The meeting ended on 12 February 2016.

2. ATTENDANCE

2.1 The meeting was attended by members and observers nominated by 28 Contracting States and 10 international organizations, as well as by advisers and others as shown in the list below:

Member	Advisor	State
C. Fernández	Eric Cócáro	Argentina
S. Rosengren	-	Australia
A. Filizola	R. Costa J. Wallacy	Brazil
G. Bourgeois	W. Bailey S. Hairsine A. Simpson S. Sankey L. Aalders	Canada
X. Liu	X. Ma X. Yang Y. Wong	China
H. Eladawy	A. G. Elsayed M. Mwafy	Egypt
J. Gilad	B. Hamon K. Guittet	France
F. Pleines-Schmidt	M. Schaefer F. Wetzel	Germany
L. Gupta		India
S. Egoli	F. Sepe (Alternate)	Italy

Member	Advisor	State
	L. Magnifico V. Foti	
D. Umezawa	S. Oshima H. Eisuke S. Tanamachi M. Hisano T. Hongo Y. Makino	Japan
M. Lunter	B. Adoléhoumé	Netherlands
T. Reklewski		Poland
S. Volkov	O. Kartyshev A. Mirzoyan V. Kopiev M. Kartyshev	Russian Federation
Tan Kah Han	J. Arsad	Singapore
K. Sim	C. Mazhetese L. Lekalakala	South Africa
A. Iglesias	A. Abajas A. Benito	Spain
M. Hankanen	M. Molitor A. Petersson T. Sjöberg J. Blomberg E. Ditlevsen	Sweden
U. Ziegler	C. Marthe (Alternate) T. Rindlisbacher	Switzerland
O. Zaporozhets	-	Ukraine
M. Clark	M. Rodmell R. Worth T. White J. Saks T. Goodwin D. Lee J. Malloy I. Jopson	United Kingdom
L. Maurice	D. Scata J. Marks J. Hileman R. Cointin R. Iovinelli G. Fleming M. Peters-Stanley P. Bonnefoy M. Samulski	United States

Member	Advisor	State
	B. Manning D. Stimson K. Welsh R. Malina	
Observer	Advisor	State/Organization
G. Lykou		Greece
Y. Gona	D. Toligi A. Fajari C. Velarde W. Aritenang	Indonesia
H. Hoiem	M. Sendstad	Norway
M. Habib	-	Saudi Arabia
Ö. Sarıunal	D. Kaymak A. Korkmaz	Turkey
M. Al Balooshi		United Arab Emirates
A. Ajili		ACAC
X. Oh	K. Preston M. Eagan L. Michaud E. Fleuti P. Ralston	ACI
N. Voorbach		CANSO
K. Winkler	P. Bombay R. Sceponaviciute W. Franken S. Arrowsmith C. Eyers A. Watt D. Brain R. Burbidge P. Vis	EU
A. Hardeman	T. Roetger M. Adam D. Chereau N. Young T. Pohle A. Menotti D. Jensen R. Brown	IATA
G. Visele	E. Cotti E. Upton	IBAC

Observer	Advisor	State/Organization
	T. Percheron D. Lye J. Dezombre L. Knaapen B. Parry A. Gertsen E. Smith	
R. Majjigi	A. Bonnet B. Pasturel C. Etter C. Grandi C. Sagues D. Allyn D. Bassani D. Becker D. Carnelly D. Collin D. Sepulveda E. Jacobs F. Couillard F. Eychenne H. Moriai J. Hoke J. Moloney J. Yu J. Zelina K. McCaldon L. Gray L. Riegle M. Beauregard M. Laby M. Wachenheim O. Penanhoat P. Genevieve P. Lempereur P. Madden P. Pagano R. Cowart R. Lapointe R. Peterson R. Solaimani S. Newsum T. Oishi W. Dolejsi Y. Cousineau Y. Yamamoto	ICCAIA
T. Johnson	K. Anastasia P. Cabezas	ICSA

Observer	Advisor	State/Organization
	B. Hemmings D. Kojak A. Murphy P. Peeters A. Petsonk D. Rutherford B. Schallert K. Watts	
R. Brons		IFALPA
K. Simeonova		UNFCCC

The meeting was also attended by:

Ambassador Olivier Caron, Representative of France on the Council of ICAO
 Mr. Maxime Millefert, Alternate Representative of France on the Council of ICAO
 Ms. Mercy Awori, Representative of Kenya to ICAO
 Ms. Harkamal Gahunia, Delegation of Kenya
 Mr. Dionisio Mendez, Representative of Mexico on the Council of ICAO
 Ms. Dulce Maria Valle Alvarez, Alternate Representative of Mexico on the Council of ICAO
 Tee Chiou Ng, Representative of Singapore on the Council of ICAO
 Mr. Mong Kai Sim, Technical Expert, Delegation of Singapore

3. OFFICERS AND SECRETARIAT

3.1 Mr. Urs Ziegler (Switzerland) was elected Chairman of the meeting and Mr. Alexandre Rodrigues Filizola (Brazil) was elected Vice-Chairman of the meeting. The Secretary of the meeting was Ms. J. Hupe, assisted by Mr. S. Bickert, Dr. N. Dickson, Ms. C. Damar, Mr. J. Laukia, Mr. J. Kurniawan (Environment Fellow, Indonesia), Mr. S. Senobua (Environment Fellow, Indonesia), Mr. T. Tanaka and Mr. T. Thrasher, of Environment, Air Transport Bureau. Also participating in the meeting were Mr. B. Djibo, Director of the Air Transport Bureau, Mr. V. Smith, Director of the Bureau of Administration and Services and Mr. G. Ville of the Air Navigation Bureau.

4. AGENDA OF THE MEETING

4.1 The agenda for the meeting shown hereunder was approved by the Council of ICAO on 6 March 2015.

Agenda Item 1: Review of the assessments of the present and future impact of aircraft noise and emissions

Agenda Item 2: Review of models and databases

Agenda Item 3: Review of technical proposals relating to aircraft engine emissions

Agenda Item 4: Particulate Matter Standard development

Agenda Item 5: CO₂ Standard development

Agenda Item 6: Review of technical proposals relating to aircraft noise

Agenda Item 7: Environmental guidance for airports and operations

Agenda Item 8: Alternative fuels

Agenda Item 9: Global market-based measure technical analysis: monitoring, reporting, and verification (MRV) and emissions unit criteria (EUC)

Agenda Item 10: Global market-based measure technical analysis: evaluation of technical proposals

Agenda Item 11: Review of current science related to aircraft noise and emissions

Agenda Item 12: Future work

5. **WORKING ARRANGEMENTS**

5.1 The technical committee met as a single body, with ad hoc drafting groups as required. Discussions in the main meeting were conducted in Arabic, Chinese, English, French, Russian and Spanish. Some working papers were presented in English only. The report was issued in Arabic, Chinese, English, French, Russian and Spanish.

6. **TERMS OF REFERENCE OF CAEP**

6.1 To undertake specific studies, as approved by the Council, related to control of aircraft noise and gaseous emissions from aircraft engines.

6.2 In its work the Committee shall take into account the following:

- a) effectiveness and reliability of certification schemes from the viewpoint of technical feasibility, economic reasonableness and environmental benefit to be achieved;
- b) developments in other associated fields, e.g. land use planning, noise abatement operating procedures, emission control through operational practices, etc.;
- c) international and national programmes of research into control of aircraft noise and control of gaseous emissions from aircraft engines; and
- d) the potential interdependence of measures taken to control noise and to control engine emissions.

7. **RULES GOVERNING CAEP**

7.1 Specific directives for CAEP were developed as CAEP Directives, which were approved by the Council in June 2011.

8. CAEP/10 WORK PROGRAMME

8.1 The Committee's work programme for this cycle was agreed during the CAEP/9 meeting and adjusted during the subsequent Steering Group meetings to accommodate the requests of the 38th Session of the ICAO Assembly. The following tables reflect the updated work programme:

Task Number	Short Title	Description
Working Group 1 (WG1 – Noise Technical) Tasks		
N.01.01	Technology, operations and goals coordination	Coordinate with other working group Rapporteurs on interdependencies related to technology, operational issues, and goals as well as harmonizing the goal setting process.
N.01.02	Databases coordination	Coordinate with other working group Rapporteurs on interdependencies related to management and update of noise and emissions databases.
N.01.03	Environmental impacts coordination	Coordinate with other working group Rapporteurs on interdependencies related to environmental impacts, including stringency.
N.01.04	SST CAEP coordination	Coordinate with other working group Rapporteurs on programmes for development of both noise and emissions SARP's for future supersonic aeroplanes.
N.02	Annex and ETM maintenance	Maintain and update Annex 16, Vol. I and ETM, Vol. I.
N.03	NoisedB	Ensure process integrity and data currency of the ICAO noise certification database.
N.04.01	Monitor research	Monitor and report on the various national and international research programme goals and milestones.
N.04.02	Technology goals benchmarking	Review progress towards achievement of Technology Goals recommended by IEs for 2020 and 2030.
N.05.01	Monitoring Sonic Boom research	Monitor and report on research to characterize, quantify and measure (including metric) sonic boom and their acceptability while also assisting in promoting and defining such research.
N.05.02	SST standards development (subsonic and supersonic regime)	Continue to work on noise certification standards for supersonic aircraft: 1) based on subsonic noise standards for local airport noise that may include the use of Variable Noise Reduction System (VNRS) technology as "acceptable means of compliance." and 2) a new scheme for supersonic flight, as informed by developments under N.05.01.
N.05.03	SST coordination	Update Air Navigation Commission with SSTG Report on progress of SST noise activities.
N.05.04	Monitoring SST	Monitor, and report on, status of SST projects and expectations for their operation (nature, frequency etc.).
N.06.01	Respond concerning Interdependencies	Respond to WG3 requests to assess interdependency effects of CO ₂ emissions stringency options with respect to noise.
N.06.02	Monitor emerging technologies	Review data on emerging technologies as it becomes available.
N.07	UAS Noise Certification Status	WG1 to review the status of UAS noise certification and inform CAEP at Steering Group 3 if there is a need for work in the next CAEP cycle regarding noise certification of UAS.

Task Number	Short Title	Description
N.08	Helicopter Noise	WG1 Technology Task Group to review the noise technology advancements of helicopters including noise technology costs, and requested that WG1 assess the extent of the helicopter noise problem, in the context of the WG1 remit, and to inform CAEP SG2015 if there is a need for formal work in the CAEP/11 cycle regarding helicopter noise.
Working Group 2 (WG2 – Airports and Operations) Tasks		
O.01	Airport community engagement	Develop a document on best practice case studies and lessons learned to assist States and the aviation industry, in particular airports, airlines and ANSPs, to engage local communities and address their concerns regarding aircraft operational noise and emissions, and aviation operations in general.
O.02	Operational Interdependencies	<p>CAEP has already carried out work on interrelationships / interdependences / trade-offs, but it is spread around a number of documents. It is really difficult to find, and there may be gaps that require to be identified and addressed. Other CAEP groups are also doing work on these from various points of view, and it would be beneficial to be able to identify and collate them together in one document or webpage on the ICAO website. This task would develop additional information on operational interdependencies for the CAEP Operations web page. To consider O.03.</p> <p>Assessment of the interrelationships information and construction of a more informative, interactive and detailed set of web-pages on operational interdependencies for the ICAO website, including a progress report and recommended completion schedule for delivery during CAEP/11</p>
O.03	“Best practice” environmental assessment.	Develop a compendium of illustrated “best practice” environmental assessment case studies that demonstrate the application of "Environmental Assessment Guidance For Proposed Air Traffic Management Operational Changes“. To consider O.02 and O.05.
O.04	Support to ANB	To be defined. Interaction with panels (e.g. OPSP).
O.05	ASBU Analysis	<p>As defined in the ASBU environmental analysis TOR.</p> <p>Input on data to be collected to support a refined ASBU benefits analysis.</p> <p>Conduct a refined ASBU benefits analysis.</p> <p>Conduct a provisional analysis of Block 1 modules</p>

Task Number	Short Title	Description
O.06	Update to Airport Planning Manual Part 2	Update the Airport Planning Manual (APM), Part 2. Incorporate eco-friendly airport planning (e.g. infrastructure decisions that facilitate environmentally-friendly airports) and best practices in land-use planning and management. Undertake full review of APM, Part 2 and propose updates to the other portions of the APM for delivery in the CAEP/11 work programme.
O.07	Update to Doc 9889	Initial update to Airport Air Quality Manual (Doc 9889). Identify certain information that requires being brought up to date, specifically those for emissions factors associated with new aircraft/engine types and Ground Support Equipment (GSE) that have entered into operations since the document was published. Propose updates to address these changes and to address clarifications sought by States on the document, and submit to WG3 for review. Address relevant feedback from WG3 when received.
Working Group 3 (WG3 – Emissions Technical) Tasks		
E.01	Interdependencies	Coordinate with other working group Rapporteurs on interdependencies related to (a) technology, operational issues and goals (b) management and update of noise and emissions databases (c) environmental impacts (d) SARPs for future SST aircraft.
E.02	Aircraft Fuel Efficiency Technology Advances	Provide assessment of advances in aircraft and engine design technologies for subsonic aircraft and the degree to which these technologies could influence the fuel burn of the aircraft including the potential interdependencies and tradeoffs with emissions and noise, and the likely timescales for introduction. Consider these in the context of the existing CAEP goals.
E.03	Combustion Technology Advances	Provide assessment of advances in engine combustor design technologies for subsonic aircraft and the degree to which these technologies could influence gaseous emissions, and particulate matter, including the potential interdependencies and tradeoffs with emissions and noise, and the likely timescales for introduction. Consider these in the context of the existing CAEP goals.
E.04	Fuel composition and emissions	Monitor trends in aviation kerosene fuel supply composition and assess consequences for emissions. Including a global survey of fuel sulphur content to support the estimation of global and regional SO _x emissions.
E.05.01	CO ₂ - Certification requirements (aircraft)	Complete an aircraft based CO ₂ emissions certification requirement.

Task Number	Short Title	Description
E.05.02	CO ₂ – Standard Stringency assessment for new types	Develop pass/fail stringency options, including TRL _{≥8} ² technology responses, for new aircraft type applicability requirements and dates of on or after 1 January 2020 and 1 January 2023 for evaluation of cost effectiveness and market impacts by FESG and MDG.
E.05.03	CO ₂ - Standard Stringency assessment for in-production types	Develop proposals for in-production aircraft type applicability requirements and dates for evaluation of cost effectiveness and market impacts by FESG and MDG. This should include consideration of pass/fail stringency options including TRL _{≥8} technology responses, reporting requirements, and transition periods.
E.05.04	CO ₂ - Regulatory standard	Recommend an aircraft CO ₂ standard including regulatory levels and applicability in accordance with the CAEP principles of being technically feasible ³ , economically reasonable, environmentally beneficial and taking into account interdependencies.
E.05.05	CO ₂ - Off-optimum performance monitoring	Low priority: Review the performance of current and emerging aircraft technology at off-optimum but relevant points in the flight envelope.
E.05.06	ICAO Aeroplane CO ₂ Emissions Metric Databank	Develop and maintain the ICAO Aeroplane CO ₂ Emissions Metric Databank.
E.06	Interdependencies	Coordinate with other groups to assess the interdependency effects of CO ₂ emissions stringency options.
E.07	Annex 16, Vol. II maintenance	Maintain Annex 16, Vol. II, taking account of updates to SAE-E31 documentation.
E.08	ETM maintenance	Maintain the emissions Environmental Technical Manual.
E.09	Emissions Database maintenance	Maintain the ICAO engine emissions certification databank.
E.10	G&R database maintenance	Review and update a "Growth & Replacement" database in order to support development of models used to populate future fleets and the replacement of retired aircraft. Coordinate with CO ₂ TG, WG1 and support groups to ensure consistency in assumptions.
E.11	NO _x cruise - Climb relationship	Review the LTO NO _x - cruise climb NO _x relationship for staged combustion and future engine technologies, to quantify control of mission emissions of NO _x , and identify any methodology issues with respect to the correlation between LTO and climb/cruise and to quantify interdependencies with other emissions.
E.12	Certification Requirements – SST	Monitor trends in supersonic technology and assess consequences for emissions and certification standards.
E.13	Certification requirements - new engine concepts	Monitor developments in new engine concepts such as open-rotor, etc. and develop methodologies for emissions certification.

² Technology Readiness Level 8 – flight qualified through test and demonstration.

³ Building on NO_x and Noise definitions of technically feasible.

Task Number	Short Title	Description
E.14.01	PM - Non-volatile	Develop an aircraft engine based non-volatile PM mass and number metric and methodology for application as a non-volatile PM mass and number emissions certification requirement for turbofan/turbojet engines >26.7kN. Note input from SAE-International E-31 Committee.
E.14.02	PM - Non-volatile	Develop an aircraft engine based non-volatile PM mass and number standard for turbofan/turbojet engines >26.7kN.
E.14.03	PM - Non-volatile	Develop representative engine data for assessing the nvPM emissions contribution from (1) turbofans/turbojets ≤26.7kN, (2) turboprops, (3) turboshaft and (4) APU engines.
E.14.04	PM - Non-volatile	Develop improved nvPM model inputs to both local air quality models and, as required, global climate models per advice from ISG. Consider collaborative work with MDG. Note input from ISG on nvPM impacts.
E.15	Fuel efficiency metric	Undertake further work to develop a fuel efficiency metric to take account of business aircraft, evaluating the possibility of using different payload factors, and potentially considering a range of factors, in order to capture operational and fleet-focused efficiencies.
Modelling and Databases Group (MDG) Tasks		
M.01	Interdependencies	Coordinate with other working group Rapporteurs on interdependencies related to technology, operational issues, goals, environmental impacts and management and update of noise and emissions databases.
M.02	CO ₂ Standard	Conduct sample problem and policy option analyses of the environmental benefits and interdependencies of a potential CO ₂ standard as directed by CAEP and SG.
M.03	ICAO Environmental Trends Projection	Conduct an updated trends projection, for the 2010 baseline case and forecasts to 2050, and for various cases which consider technology, operational improvements and alternative fuels life cycle. The projection will consider incorporation of information from state action plans as interpreted and provided to MDG by the ICAO Secretariat. Updated trends projection for Noise and Local Air Quality.
M.04	Update to CAEP/10 ICAO environmental trends	The input from S3.4 would be applied to the fuel burn trends prepared in Task M.03 to constitute the updated fuel burn trends for CAEP/10.
M.05	Existing Model and Database Management	Maintain version control of models and databases to be used in support of specific CAEP analyses. Determine if updates to models or databases require a re-evaluation.

Task Number	Short Title	Description
M.06	New Model Evaluation	If new models are introduced to support CAEP/10, continue the candidate model evaluation process, which calls for sensitivity tests, comparisons with “gold standard data, and sample problems. Refine the process as appropriate on the basis of relevant criteria, to better inform CAEP which tools are sufficiently robust, rigorous and transparent, and appropriate for which analysis, and why there might be differences in modelling results.
M.07	Document 9911	Review and update ICAO Document 9911, as appropriate.
M.08	Fuel Burn Reporting	Seek to improve modelling and State reporting of fuel burn data by conducting a comparative assessment of modelled and reported data from member states, as reported data becomes available. Scope validation of the methods used in ICORAS to assess the progress achieved toward the global aspirational goals. Validation of ICORAS
M.09	ICAO Support	Provide support to ICAO Secretariat in dissemination of MDG results.
M.10	PM Standard	Conduct sample problem and policy option analyses of the environmental benefits and interdependencies of a potential PM standard as directed by CAEP and SG. In cooperation with other CAEP WG's.
M.11	ASBU Analysis	Note: WG2 has the lead on this task. As defined in the ASBU environmental analysis TOR. Input on data to be collected to support a refined ASBU benefits analysis. Conduct a refined ASBU benefits analysis.
M.12	COD Improvement(s)	Broaden the scope of the Common Operations Database (COD) and manage the acquisition and treatment of the additional data
M.13	Feasibility of ICAO climate change goals	Analysis of the feasibility of achieving ICAO goals for international aviation and climate change, consistent with A38-18
M.14	ADAP Participation	FESG/MDG to coordinate work with the ICAO multi-disciplinary group on aviation data and forecasts through Aviation Data and Analysis Panel (ADAP).
Forecasting and Economic Analysis Support Group (FESG) Tasks		
F.01	Review of Economic Models	Review of economic models as needed for the CAEP/10 analyses.
F.02	Review of FESG CAEP/9 forecast	Review of the CAEP/9 forecast to address potential issues and facilitate its implementation in support of the CAEP/10 analyses.
F.03	Cost-effectiveness analysis of potential CO ₂ policy options	Conduct the cost-effectiveness analysis of the potential CO ₂ policy options under consideration for CAEP/10.

Task Number	Short Title	Description
F.04		Removed at Steering Group 2014
F.5	ADAP Participation	FESG/MDG to coordinate work with the ICAO multi-disciplinary group on aviation data and forecasts through Aviation Data and Analysis Panel (ADAP).
Impacts and Science Group (ISG) Tasks		
I.01.01	Coordination (internal group)	Coordination on activities.
I.01.02	Coordination (internal ICAO)	Coordination with other WGs, TFs, RFPs, etc. Rapporteurs and ICAO Secretariat on activities.
I.02	Environmental impact seminar	ISG to hold an ICAO seminar to build upon outcomes of the 2007 Impacts Workshop. Exact topics are yet to be determined. Potential topics that respond to other WG issues could include: climate impacts of aviation NOx emissions, PM emissions and their impact, and simplified approaches to quantifying climate benefits of system improvements (e.g. technologies that improve fuel efficiency); noise impacts.
I.03	Climate context (non-CO ₂) Coordinate with MDG as needed	ISG to summarize and critique ongoing research on contrail avoidance, including predicting contrail prone areas and routing to avoid them.
I.04	Local and surface air quality context	ISG to provide an update to the current White Paper under development for CAEP/9 on air quality, with a focus on particulate matter.
I.05	Climate context	ISG to provide an update to the current White Paper under development for CAEP/9 on aviation impacts on climate.
I.06	Climate context	ISG to develop a new White Paper for CAEP/10 summarizing knowledge regarding the impacts of climate on aviation operations, from a science perspective.
I.07	Support the ICAO Secretariat in requesting an IPCC update	Support the ICAO Secretariat in requesting that the IPCC update their figures regarding the distribution of global CO ₂ emissions by Sector.
I.08	Estimation of global peer-reviewed CO ₂ emissions by Sector	Compile peer-reviewed estimates of global CO ₂ emissions by sector that can be used by ICAO, in the interim, pending updated IPCC figures and present their results to the first Steering Group meeting of the CAEP/10 cycle.
I.09	Effects of aviation noise	Include the effects of aviation noise in ISG study topics during the CAEP/10 cycle. Only a review of peer-reviewed studies, not undertaking new studies.
I.10	Assessment of Climate Change Risk	Consider including the monitoring and communication of climate change risk and resilience in the CAEP/10 Work Programme.
I.11		Removed by CAEP members call after Steering Group 2013
I.12	Commercial space access impacts	Short paper on noise and emission impacts issues associated with commercial space access

Task Number	Short Title	Description
Aviation Carbon Calculator Support Group (ACCS) Tasks		
C.01	Offset Accounting Methodology	Develop a methodology to estimate the amount of emissions on an airport-pair basis that would have been offset by the operator as the result of exceeding their emissions allowances within a cap and trade system or other offsetting schemes.
C.02	Enhancements to Passenger Carbon Calculator	ACCS to consider the input from the Assembly in connection with updates to the Carbon Calculator.
C.03	Estimating CO ₂ Emissions from Air Freight	Develop a methodology for estimating the CO ₂ emissions associated with air freight.
C.04	Methodology to Account for Carbon Offsets in the ICAO Carbon Calculator	Assist the ICAO Secretariat in developing a methodology consistent with the recommendations from Task C.01 and define the precise requirements for obtaining data.
C.05	Collection of offset data	Input from ACCS on the collection of offset data.
Alternative Fuels Task Force (AFTF) Tasks		
S1	Requirement analysis	Analyze issues involved in the alternative fuel emissions assessment and define the scope for the proposed assessment.
S2.1	Methodology for fuel life-cycle emissions assessment	Propose a methodology for fuels life-cycle emissions assessment for the purpose of ICAO's environmental trends projections and as the suggested methodology for the action plans. This should include a review of key methodological parameters in the LCA approach with impacts on results (a workshop could contribute to this task), methodology to account for uncertainties and analysis of the consistency of emissions reporting with other existing reporting scheme.
S2.2	Quantifying fuel life-cycle emissions	Quantify life-cycle emissions of the fuel from the projected scenario of production of alternative jet fuels. This includes reviewing existing applicable results and defining a methodology to account for fuel emissions variability.
S2.3	Support to GMTF	Provide support to GMTF in the area of life-cycle analysis methodologies for alternative fuels as required
S3.1	Review of projected production of alternative fuels	Review existing projection work on future production and use of alternative fuels.
S3.2	Methodology for future alternative fuels production	Define approach(es) for assessing future alternative jet fuel production scenarios, and define associated hypothesis.

Task Number	Short Title	Description
S3.3	Quantification of the range of the production alternative jet fuels to 2050	Apply the selected methodology to build and quantify scenario(s) for future alternative fuels production.
S3.4	Quantification of the range of emissions from alternative jet fuels to 2050	On the basis of S2.2 and S3.3, quantify the range of emissions reductions from alternative jet fuels to 2050.
Global Market-based Measures Technical Task Force (GMTF) Tasks		
G.1	Review existing MRV procedures	Review existing and emerging MRV procedures and requirements that relate to aviation and broader methodologies related to fuel burn and CO2 emissions. Draft final conclusions and results into <u>Background Report</u> .
G.2	Preliminary recommendations on monitoring emissions	Based on the task G1, provide preliminary recommendations on monitoring procedures considering monitoring methodologies and data sources, administrative burden, cost and accuracy, technology tools and managing business sensitive information.
G.3	Preliminary recommendations on reporting procedures	Based on the task G1, provide preliminary recommendations on reporting procedures including reporting cycles, standardized templates, reporting entities and competencies and possible support tools.
G.4	Preliminary recommendations on verification procedures	Based on the task G1, provide preliminary recommendations on verification procedures to ensure emissions are fairly accounted for and procedures are auditable using defined accreditation mechanisms (e.g. bodies, standards, criteria) with guidelines and procedures.
G.5	Develop MRV procedures to avoid unnecessary administrative burden while maintaining environmental integrity	Assess and analyze administrative burden on different accountable entities with different levels of activity for the purpose of recommending simplified reporting procedures.
G.6	Develop procedures for MRV of alternative fuels used by international aviation	Building on the progress by the CAEP Alternative Fuels Task Force (AFTF), develop procedures for monitoring, reporting and verification of alternative fuels used by international civil aviation.
G.7	Final recommendations on MRV procedures	Review of MRV recommended procedures, based on consultations and inputs from States and stakeholders and recommend administration and legal set-up of MRV proposed requirements
G.8	Review and evaluate eligibility of emission units	Evaluate how and under what criteria, existing or future emissions units could be used in a global MBM aviation scheme.

Task Number	Short Title	Description
G.9	Recommend eligibility criteria for emission units taking into account carbon market supply and demand	Develop recommendations on eligibility criteria for offset credits and other emissions units and develop an assessment of future availability of emission units and impact of international civil aviation on the carbon market supply, demand and price based on the recommended criteria.
G.10	Final recommendations on eligibility criteria for emission units	Revise recommendations based on consultations and inputs from States and stakeholders
G.11	Analysis of global MBM scheme elements	Report to ICAO Council Environment Advisory Group the impact of quantitative analysis on the options and approaches outlined in the strawman (e.g. the draft global MBM scheme)
G12	Coordination of MBM design and assessment	Coordinate with CAEP Rapporteurs and relevant ICAO groups to develop elements of a global MBM scheme and support the analysis of the scheme
WG1, WG2, WG3, MDG and FESG (WMF) Tasks		
WMF.01	CO ₂ Standard Technical Liaison	Coordinate across all relevant groups to clarify key assumptions, define analysis requirements, and identify database and modelling needs to support policy option analysis of a CO ₂ standard.
WMF.02	Progress reports	Report on progress being achieved toward delivering the CO ₂ Standard.
All Working Groups Tasks		
A.01	Support liaison activities with other UN bodies.	Provide the support required by liaison activities held in cooperation with other UN bodies.
A.02	Support to ICAO Secretariat	Provide support to the ICAO Secretariat activities in the fulfillment of tasks stemming from the relevant Assembly resolutions.
A.03	WG coordination	Coordination will need to continue throughout the CAEP/10 work cycle on existing and future work items.

9. OPENING REMARKS BY THE PRESIDENT OF THE COUNCIL (DELIVERED BY THE FIRST VICE PRESIDENT OF THE COUNCIL)

9.1 As the first Vice-President of the ICAO Council, and on behalf its Representatives and the President of the Council, it's my great honour to welcome you today to this important Tenth Meeting of ICAO's Committee on Aviation Environmental Protection (CAEP). Please accept President Aliu's sincere regrets that he could not be here to welcome you himself today.

9.2 Last December, the landmark COP21 event concluded with the adoption of the Paris Agreement. As we are all aware, international aviation was not directly covered under the Paris Agreement text, and our global community has acknowledged this outcome as a clear vote of confidence in the environmental progress being achieved by States through ICAO.

9.3 We should therefore view the Paris Agreement as lending considerable momentum toward further progress on aviation environmental protection goals at the next ICAO Assembly in September 2016, and it goes without saying that the CAEP and its critical technical work remain key to that success. For example, ICAO Member States' Action Plans for international aviation can be viewed as parallel to the UNFCCC Parties' Nationally Determined Contributions (NDCs) for mitigation of other domestic emissions. I therefore wish to encourage CAEP members and observers to continue supporting the development, refinement and implementation of States' Action Plans.

9.4 The world will be looking to this Tenth Meeting of the CAEP to deliver several vital recommendations. One of the most important will be for a new aeroplane CO₂ emissions certification standard – an undertaking which has represented a tremendous amount of work and which will eventually require a new Volume III to Annex 16. Your efforts, with respect to both developing the standard and to producing a detailed analysis of its environmental benefits and cost-effectiveness, have been greatly appreciated. The last Assembly acknowledged the importance of having the CO₂ Standard by 2016, and ICAO will look forward to your recommendation on this subject at this Meeting.

9.5 Another very important undertaking by the CAEP has been your technical work to support the development of an international aviation global market-based measure (GMBM) scheme. These efforts included comprehensive analyses of various approaches on the GMBM, as well as the development of recommendations covering Emissions Units Criteria (EUC), Monitoring, Reporting and Verification (MRV) requirements, and registries for the scheme. This work has been of paramount importance to the work of the Council and its Environment Advisory Group (EAG), and I am very grateful on this occasion to be able to express our profound appreciation for how you have responded to our requests in such a consistently timely and professional manner – in many instances at the expense of your personal and family time.

9.6 In November of last year, the Council agreed on a number of steps to be taken in 2016, including the convening of the second series of Global Aviation Dialogues (GLADs) and the upcoming High-level Meeting. These initiatives will be instrumental to delivering a fully informed recommendation on a practical GMBM for international aviation to the Assembly, and the material prepared by the CAEP will be essential to their respective outcomes.

9.7 Alternative fuels also remain a key component in aviation's Basket of Measures to reduce aviation CO₂ emissions, and we are aware of the CAEP's view that further policy actions will be needed to accelerate their appropriate development, deployment and use. This meeting will consider a Life Cycle Assessment (LCA) methodology proposal for sustainable alternative fuels, as well as the quantification of future production volumes, and some of your deliberations will also inform how we eventually incorporate alternative fuels operations within the MRV system of the GMBM.

9.8 In addition to this substantial work on international aviation's CO₂ emissions, this Meeting will also be an important first step in setting a standard for aviation-induced non-volatile Particulate Matter (nvPM). This will assist with our progress on local air quality issues, as well as related activities aimed at advancing aviation's goals for aircraft noise reduction.

9.9 Regarding noise reduction efforts more specifically, under the current CAEP cycle you have considered: the status of helicopter noise technology; the current state of noise certification for Unmanned Aircraft; and the important work of maintaining Annex 16, Volume I.

9.10 The Council has also been encouraged that your work has progressed on a new noise standard for supersonic aircraft, and I would highlight in this context that new approaches to related technologies may see this work becoming pertinent much sooner than some may have expected.

9.11 Lastly I would draw our attention to the CAEP's work on the ICAO trends on noise, NOx and CO₂. This work is of paramount importance and permeates many deliberations of the ICAO Assembly. Assessments, studies and projections on air transport growth and current and future impacts of international civil aviation operations come up frequently in the media – each based on varying assumptions and presenting disparate results, which in some cases largely overestimates the impacts of aviation on climate change.

9.12 The ICAO CAEP trends are therefore essential to our goal of providing common, authoritative information to the ICAO Assembly, and will aid in our efforts to achieve consensus amongst States and international organizations, including industry, environmental NGOs, and academia. I therefore urge you to stay mindful of the importance of this work, and of our great appreciation for the tremendous level of responsibility associated with it.

9.13 In concluding ladies and gentlemen, let me please stress that the CAEP has earned an enviable global reputation for solving complex technical issues, and that from every imaginable standpoint, that reputation is very well deserved. Your work over the next two weeks will be key to the environmental solutions which ICAO's States agree upon and adopt at our upcoming 39th Assembly, with lasting impacts on our planet and civil society for many years to come.

9.14 I would also like to highlight that the ICAO Council and its President deeply appreciate your professionalism in preserving the technical nature of your work. I know that this is not an easy task given the topics at hand today, but it is fundamental to the relevance and integrity of the work of the Committee. This Organization has other political deliberative bodies which provide a suitable forum for political considerations.

9.15 Let me please thank you again for your immense dedication and support for ICAO's work, and I wish you all a very productive 10th Meeting.

— — — — —

GENERAL

1. MEMBERSHIP AND PARTICIPATION IN CAEP ACTIVITIES

1.1 CAEP currently consists of 22 members and 17 observers. Since CAEP/9, two new observers have joined the committee, namely, Saudi Arabia and Peru, and New Zealand ceased to be an observer to CAEP. There have been changes of representative for CAEP member States from Brazil, France, Italy, Japan, South Africa, Sweden and the United Kingdom. There have been two changes of representative for observer States, namely, Greece and Norway and four changes of representative for international organizations, namely, Arab Civil Aviation Commission (ACAC), Civil Air Navigation Services Organization (CANSO), International Coordinating Council of Aerospace Industries Associations (ICCAIA) and European Union (EU).

1.2 In accordance with the CAEP Directives, Tunisia lost its CAEP membership status.

2. DEVELOPMENTS IN OTHER UN BODIES

2.1 UNITED NATIONS FRAMEWORK CONVENTION ON CLIMATE CHANGE (UNFCCC)

2.1.1 Parties to the UNFCCC undertook critically important negotiations, with a view to reaching an agreement on climate change applicable to all Parties for implementation from 2020, which was adopted at the 21st Session of the Conference of the Parties (COP21) to the UNFCCC in Paris, France, in December 2015.

2.1.2 At the COP21, ICAO provided a statement on recent ICAO developments in addressing emissions from international aviation. During the ICAO/IMO joint side event, ICAO showcased its recent developments, including the partnerships recognized at the ICAO Global Aviation Partnerships on Emissions Reductions (E-GAP) Seminar (see paragraph 3.6 below). ICAO also provided statements and speeches at various side events, and undertook more than 20 bilateral meetings with chairs of subsidiary bodies, heads of governments and international organizations in order to highlight the importance of ICAO's efforts and role.

2.1.3 In the evening of Saturday, 12 December 2015, the Paris Agreement and associated COP21 decision text was adopted by the conference (FCCC/CP/2015/L.9/Rev.1)⁴ which did not include reference to international aviation. ICAO Member States continue to work on the basis of ICAO agreed instruments (e.g. ICAO Assembly Resolution A38-18). The conference decided to invite ICAO to continue to report its progress of work to future sessions of the UNFCCC Subsidiary Body for Scientific and Technological Advice (SBSTA).

2.1.4 The fact that international aviation was not covered under the Paris Agreement could be considered to be a vote of confidence in the progress that ICAO and its Member States have achieved thus far. The Paris Agreement provides the aviation community with further momentum toward success at the 39th ICAO Assembly in September 2016.

⁴ http://unfccc.int/documentation/documents/advanced_search/items/6911.php?preref=600008831

2.1.5 One of the key outcomes of the Paris Agreement was a clear objective to hold the increase in the global average temperature to well below 2 degrees Celsius and to pursue efforts to limit the temperature increase to the 1.5 degrees Celsius above pre-industrial levels. The IPCC estimates that approximately 1,000 Gt of CO₂ remain to be emitted before 2100 in order to hold the global temperature increase to 2 degrees Celsius, and ICAO may need to consider its share of emissions in the “carbon budget” in the context of the feasibility of a possible long-term aspirational goal and related actions for international aviation.

2.1.6 The Paris Agreement also includes the establishment of a new mechanism to allow the use of internationally transferred mitigation outcomes, and ICAO needs to closely follow up the evolution of the relevant discussions on such a new mechanism in the future UNFCCC process and its possible implications to ICAO’s work on a global market-based measure scheme for international aviation.

2.1.7 Making further progress on the ICAO’s capacity building and assistance strategy to support the development and implementation of Member States’ Action Plans for international aviation would be of another critical importance, as they constitute a parallel to the UNFCCC Parties’ Nationally Determined Contributions (NDCs) for mitigation of other domestic emissions.

2.1.8 The observer from the UNFCCC provided a statement to update the meeting on the results of the COP21 conference.

2.2 UNFCCC CDM Methodologies

2.2.1 As part of its cooperation with the UNFCCC Secretariat, the ICAO Secretariat has been developing the methodologies under the UNFCCC Clean Development Mechanism (CDM) that would be applicable to aviation projects. Two methodologies: “Solar power for domestic aircraft at-gate operations” and “electric taxiing systems for airplanes” were developed, and the CDM Executive Board in November 2015 approved the e-taxing methodology, and efforts continue to finalise the approval process of the solar at-gate methodology.

2.2.2 The CAEP Secretary conveyed appreciation for the UNFCCC Secretariat for its support to this joint effort and recognized the successful work undertaken by the ICAO Secretariat staff, including the expertise and dedication of a secondee from China.

2.3 INTERNATIONAL MARITIME ORGANIZATION (IMO)

2.3.1 The International Maritime Organization (IMO) Maritime Environment Protection Committee (MEPC) held its 68th session in May 2015. It agreed on further technical guidelines to support the implementation of technical and operational measures to improve fuel efficiency from international shipping adopted by the MEPC⁵. It also considered the development of an emission data collection system, and agreed on further inter-sessional work to be undertaken. It further discussed a proposal by the Marshall Islands on establishment of a global emissions reduction target for international shipping, and agreed to postpone further consideration of this issue at the next 69th session of the MEPC in April 2016.

2.4 UN Environmental Management Group (EMG)

2.4.1 The UN Environment Management Group (EMG) was established by the UN General Assembly in 1999, and its mandate covers coordinated approaches, information exchange, promotion of

⁵ Amendments to Annex VI of the MARPOL Convention in 2011 to add a new chapter to make the application of the Energy Efficiency Design Index (EEDI) mandatory for new ships, and the application for the Ship Energy Efficiency Management Plan (SEEMP) mandatory for new and existing ships

joint action by UN agencies and synergy among the UN activities on a cluster of environment issues. The EMG is chaired by the Executive Director of UNEP. All agencies of the UN system, including ICAO, are EMG members.

2.4.2 ICAO has been playing an important role in the EMG, particularly with respect to the initiatives of the UN Secretary-General on the Climate Neutral UN initiative. Since 2008, the ICAO Carbon Emissions Calculator is the official tool used to estimate the air travel-related portion of UN agencies' carbon inventories, while the UNEP methodology estimates the non-air travel portion.

2.4.3 The ICAO Secretary General participated in the 21st Senior Officials Meeting of the EMG held on 24 September 2015 at UN Headquarters in New York. Topics discussed included: a UN System-wide strategy on the environment as a means to contribute to the environmental sustainability dimension of the 2030 Sustainable Development Goals (SDGs). The results of the EMG meeting will serve as input to the Second Meeting of the UN Environment Assembly to be held in 23 to 27 May 2016 in Nairobi, Kenya.

2.5 UN Sustainable Development Goals (SDGs) Summit

2.5.1 The UN Summit for the adoption of the 2030 SDGs was held from 25 to 27 September 2015 at UN Headquarters in New York. The ICAO Secretary General participated in the Summit, conveying the important contributions of international aviation, and the ICAO activities, to the achievement of UN SDGs.

2.5.2 Out of the 17 SDGs that were adopted, ICAO's various areas of work contributes to 13 SDGs and ICAO's environmental-work contributes to ten SDGs (see <http://www.icao.int/about-icao/aviation-development/Pages/SDG.aspx>).

2.5.3 CAEP's work contributes to a number of environment-related SDGs, including: CAEP's work on aircraft noise, NO_x and particular matter (PM) for SDG 3 (health), and CAEP's work on alternative fuels for SDG 7 (access to renewable energy). Potential future work by CAEP on adaptation would contribute to SDG 9 (resilient infrastructure), and various CAEP tasks are related to SDG 13 (take urgent action to combat climate change and its impacts).

2.5.4 As next steps, CAEP might consider a process to track the contributions of CAEP's activities to the achievement of UN SDGs, such as mapping of the CAEP work programme to relevant SDGs, development of "indicators" to monitor the progress of CAEP work's contributions to the relevant SDGs, and regular updates of progress and reporting to the Council.

2.6 UN Secretary General's High-level Advisory Group on Sustainable Transport

2.6.1 The objective of the UN Secretary General's High-level Group is to promote sustainable transport that is in line with inclusive and equitable growth, social development, protection of the global environment and ecosystems, and addressing climate change. Two representatives from aviation were nominated as members of the Advisory Group, specifically Mr. Tewolde Gebremariam, the Ethiopian Airlines CEO and Ms. Nancy Young, Vice President of Environmental Affairs at A4A. ICAO Secretariat also participates in the meeting of the supporting technical working group. The Advisory Group and the technical working group met during the UNFCCC COP21 conference in Paris.

2.7 Discussions and Conclusions

2.7.1 CAEP encouraged the active participation of States' representatives and their technical experts in the UNFCCC process to ensure that ICAO's developments on international aviation and climate change are recognized and taken into account in the UNFCCC process, as well as to follow up the evolution of relevant UNFCCC discussion, such as on the establishment of a new mechanism and its possible implication to ICAO's work on a global market-based measure scheme for international aviation.

2.7.2 The meeting noted the contribution of ICAO's work to the achievement of the UN SDGs and agreed to consider during their discussion on future work how to assess the contributions of CAEP's activities, in the context of the SDGs, in light of further information to be provided by the Secretariat.

3. DEVELOPMENTS IN ICAO

3.1 States' Action Plans

3.1.1 The State Action Plan capacity building and assistance initiative was initiated by the 37th ICAO Assembly Session in 2010. States were invited to voluntarily prepare and submit to ICAO an action plan on CO₂ emissions reduction activities. CAEP has provided support, including the review of the dedicated website (APER), the refinement of Doc 9988, *Guidance on the Development of States' Action Plans on CO₂ Emissions Reduction Activities* and, more recently, the review of the Rules of Thumb developed by the Secretariat to assist States developing more robust action plans. Since the 38th Session of the ICAO Assembly, the Secretariat organized seven seminars across all ICAO regions, from April 2014 to March 2015, with the participation of CAEP Members and Observers. The material provided in each seminar is available on the ICAO action plan website⁶.

3.1.2 As of 8 January 2016, with the support of ICAO, 86 States have submitted their action plans representing more than 80 per cent of global international aviation revenue tonne kilometres (RTK). The Secretariat continues to contact national action plan focal points directly in order to assist them in developing and updating their action plans. To date, more than 100 focal points have been nominated and trained. By the 38th Session of the ICAO Assembly in 2013, 72 State Action Plans had been submitted. By the next ICAO Assembly in 2016, the number of action plans submitted by States will likely be 50 per cent greater, and 50 per cent of the action plans submitted in 2013 will be updated.

3.1.3 The meeting was provided with a synthesis report with the initial assessment of submitted States' action plans, which is expected to be updated in time for the 39th Assembly.

3.2 ICAO State Action Plans “Buddy” Programme

3.2.1 The State Action Plan capacity building and assistance initiative is a concrete and successful example of the ICAO “No Country Left Behind” campaign. Various forms of support between States have been provided, bilaterally, regionally, and inter-regionally, such as the ICAO-EU assistance project for African and Caribbean States (see paragraph 3.3 below). The 38th Assembly also “encourages States that already submitted their action plans to share information contained in their action plans and build partnerships with other member States in order to support those States that have not prepared their action plans” (Assembly Resolution A38-18, paragraph 13).

3.2.2 In moving forward to reach out other States that require support in the development and implementation of their action plans, CAEP member and observer States with knowledge and experience

⁶ <http://www.icao.int/Meetings/EnvironmentalWorkshops/Pages/2014-Seminars.aspx>

in the field are encouraged to take lead in building “buddy” partnerships with States not represented in CAEP to support the development and implementation of their action plans. As part of the ICAO Action Plan Buddy Programme, the Secretariat is developing a template that could facilitate the establishment of such a partnership between States.

3.3 Assistance to States

3.3.1 As part of the ICAO capacity building and assistance strategy for the development and implementation of States’ action plans on CO₂ emissions reduction activities, since 2013, ICAO has established two partnerships.

3.3.2 The ICAO-EU assistance project, *Capacity Building for CO₂ Mitigation from International Aviation*, is a 6.5 million Euro project to assist fourteen States from Africa and the Caribbean in the development of their action plans; setting up of their Aviation Environmental Systems (AES); and implementing mitigation measures to reduce aviation emissions. The national action plan teams have been established in all the selected States to develop their action plans, and AES have been developed and implemented to enable the monitoring of CO₂ emissions. In 2016, ICAO will continue to support these States in the implementation of the mitigation measures included in the action plans.

3.3.3 The ICAO-UNDP-GEF assistance project, *Transforming the Global Aviation Sector: Emission Reduction from International Aviation*, is a USD 2 million global project, which includes the development of guidance documents and supporting mechanisms to assist the identification and implementation of measures to reduce aviation CO₂ emissions for developing States and Small Island Developing States (SIDS), as well as a pilot project in Jamaica consisting of the implementation of a measure that could be replicated in other States.

3.4 ICAO environmental tools

3.4.1 In order to inform the effect of the mitigation measures described in States’ action plans, it is imperative that States submit action plans with quantified expected results on CO₂ emissions from international aviation. In order to ensure that all States would be able to quantify the results from their proposed actions, the Secretariat, with the support of the CAEP ad hoc group, completed a comprehensive revision of Doc 9988.

3.4.2 The updated guidance includes rules of thumb that can be used to estimate the benefits from elements of the basket of measures. The emissions quantification elements of Doc 9988 have been automated in a software tool, known as the Environmental Benefits Tool (EBT). This is in addition to the previously-developed tools, such as the ICAO Carbon Emissions Calculator and the ICAO Fuel Savings Estimation Tool (IFSET). The combination of the revised Doc 9988 and the EBT aims to facilitate that all States are able to submit an action plan with quantified results.

3.4.3 A “Green Your Airport” e-collection, including best practices, will be launched after the CAEP/10 meeting in order to respond to States’ growing needs for ready-to-use information to support the planning and implementation of airport infrastructure projects to deliver environmental benefits. The timing of this e-collection is critical, as public expenditure into airport infrastructure occurs now. The deliverables will be a series of short publications accessible from the ICAO Environment website. Each publication will focus on a specific aspect of environmental planning at airports and aim to share good practice that has been put in place in airports around the world. This Secretariat-led initiative would benefit from the review of experts within CAEP.

3.5 Global Market-based Measure

3.5.1 Following the agreement of the 38th ICAO Assembly on the development of a global MBM scheme for international aviation, significant efforts are being made as Member States, the aviation industry and other stakeholders move forward in developing a recommendation for a global MBM scheme capable of being implemented from 2020 for decision by the 39th ICAO Assembly in 2016.

3.5.2 Progress is being achieved by the ICAO Council's Environment Advisory Group (EAG) with technical support provided by CAEP, which started discussion with a simple and basic proposal for a global MBM scheme with a view to generating the discussion and analyses on advantages and disadvantages of design elements. As of January 2016, the EAG met 15 times and CAEP has been providing support on some design elements of a global MBM scheme, i.e. monitoring, reporting and verification (MRV), emission units criteria (EUC) and registries, and on analytical work of proposed global MBM elements.

3.5.3 As a means to ensure the full engagement of States and other stakeholders and the widest possible range of inputs, ICAO conducted the first round of five regional seminars – MBM Global Aviation Dialogues (GLADs) in April 2015. The material provided during the GLADs has been made available on the ICAO website⁷.

3.5.4 As decisions of the recent 206th Session of the Council in November 2015, the second round of regional GLADs will be held during the period from 20 March to 8 April 2016 in five venues, followed by the convening of a High-level Meeting on a global MBM scheme in Montreal from 11 to 13 May 2016, to make further progress in delivering a recommendation on a global MBM scheme. Recalling the success of the 1st round of GLADs due to involvement of CAEP experts as facilitators of GLADs dialogue groups, the Secretary expressed that CAEP experts would be expected to play an important role during 2nd round of GLADs.

3.5.5 The EAG15 meeting in January 2016 undertook first consideration of a draft proposal on a global MBM scheme, and a High-level Group was established to further consider the draft proposal, at its meeting from 24 to 25 February 2016. The Group is expected to recommend a proposal to the 207th Session of the Council in March 2016, when agreement will be sought on the basis proposal for consideration of the 2nd GLADs and the High-level Meeting.

3.6 ICAO Global Aviation Partnerships on Emissions Reductions (E-GAP) seminar

3.6.1 The ICAO *Global Aviation Partnerships on Emissions Reductions* (E-GAP) Seminar was held in Montréal, Canada from 16 to 17 September 2015, and provided a forum to showcase the synergistic effects of ICAO's ongoing partnerships with governments and other organizations for action to reduce emissions from international aviation.

3.6.2 The Seminar addressed various topics on aviation and the environment, and more than a thousand partnerships were showcased during the Seminar, and further synergies, partnerships and areas of cooperation were identified, including those in new areas such as aircraft recycling and adaptation to climate change. The presentations and videos delivered during the Seminar, as well as publication on the Seminar's results are available at <http://www.icao.int/meetings/EGAP/>.

3.6.3 Two members described that they are advancing a number of research efforts to understand and mitigate the environmental impacts of aviation. Under the auspices of the Next

⁷ <http://www.icao.int/meetings/GLADs-2015/Pages/default.aspx>

Generation Air Transportation System (NextGen), the United States Federal Aviation Administration (FAA), in collaboration with other government departments and agencies and aviation stakeholders, continues to advance and implement its five-pillar strategy to address aviation environmental and energy issues (advance science and modelling tools; aircraft technologies; sustainable alternative fuels for aviation; operational procedures; and policy measures and environmental standards). These efforts are being conducted in collaboration with Transport Canada through the Aviation Sustainability Center (ASCENT), the Center of Excellence for Alternative Jet Fuels and the Environment. In addition, under the Clean Transportation Initiative, Transport Canada, in collaboration with the National Research Council and aviation stakeholders, is funding projects to reduce aviation emissions in support of Government of Canada priorities.

3.6.4 An observer shared their experience in establishing partnerships with another State, as well as with the airlines and aircraft manufacturers in support of capacity building, resulting in the development of their action plan on emissions reduction. This cooperation is expected to lead to successful implementation of the measures identified in their action plans.

Discussions and Conclusions

3.6.5 A member recommended that the Secretariat present EBT to the first meeting of MDG during the CAEP/11 cycle for information.

3.6.6 The meeting acknowledged the progress of the States' Action Plans initiative and urged ICAO to continue providing support to its Member States for the development and implementation of their States' Action Plans. The meeting noted a number of examples of cooperation among States similar to the ICAO "Buddy Programme" that are already underway. The meeting encouraged other CAEP member and observer States to participate in the "Buddy Programme" and consider establishing partnerships with other States to support their development and implementation of action plans.

Agenda Item 1: Review of the assessments of the present and future impact of aircraft noise and emissions

1.1 GLOBAL ENVIRONMENTAL TRENDS

1.1.1 The MDG Co-Rapporteurs presented the result of the future trends assessments for aircraft noise, aircraft engine emissions that affect local air quality, and aircraft engine emissions that affect the global climate.

1.1.2 Aircraft Noise Trends

1.1.2.1 Aircraft noise was modelled for the period 2010 through 2040 with the four scenarios as presented in Appendix A.

1.1.2.2 Figure 1.1 provides results for the total global contour area from aircraft noise above 55 DNL for 2010, 2020, 2030 and 2040 for the four scenarios. These results include noise from all operations at 321 world airports, regardless of whether the operation is an international or a domestic flight. The 2010 baseline value is 13,975 square km. In 2040, total global contour area ranges from 16,189 square km with Scenario 4 to about 22,449 square km with Scenario 2. As is seen in Figure 1.1, under the advanced technology scenario and moderate operational improvements scenario, “peak day-night average sound level” may be reached in 2030 in terms of contour area, meaning that beyond that time, the projected increase in aircraft operations will no longer result in an increase in noise contour area.

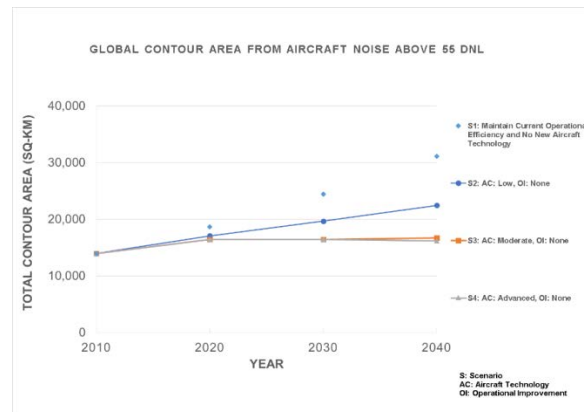

Figure 1.1. Global Contour Area from Aircraft Noise above 55 DNL.

1.1.3 Aircraft Engine Emissions Trends That Affect Local Air Quality

1.1.3.1 Aircraft NO_x emissions and particulate matter (PM) emissions below 3,000 feet above ground level were modelled for the period 2010 through 2040 for the scenarios defined in Appendix A. Figure 1.2 presents global aircraft NO_x emissions, for both domestic and international operations, below 3,000 feet above ground level. The 2010 baseline value is 0.30MT of NO_x. In 2040, the value ranges from 0.65 MT of NO_x in Scenario 3 to 0.86 MT of NO_x in Scenario 2. Figure 1.3 presents global aircraft PM emissions, for both domestic and international operations, below 3,000 feet above ground level. The 2010 baseline value is 2,239 Metric Tonnes of PM. In 2040, global aircraft PM emissions below 3,000 feet above ground level are 6,709 Metric Tonnes of PM with Scenario 2. It is important to note that NO_x emissions results are presented in units of mega-tonnes, which are millions of metric tonnes. PM

emissions are presented in terms of tonnes, that is, mass units that are 1,000,000 times smaller than those used for the NO_x emissions.

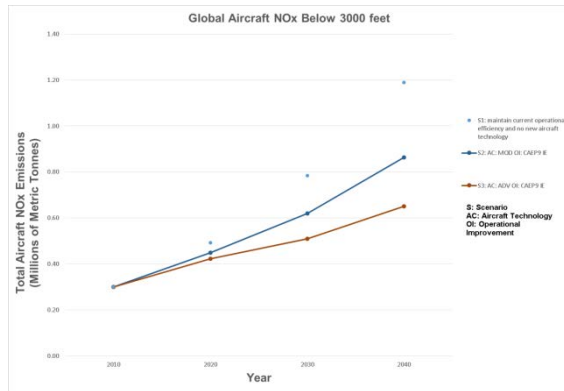

Figure 1.2. Total Global Aircraft NO_x Emissions Below 3,000 Feet Above Ground Level

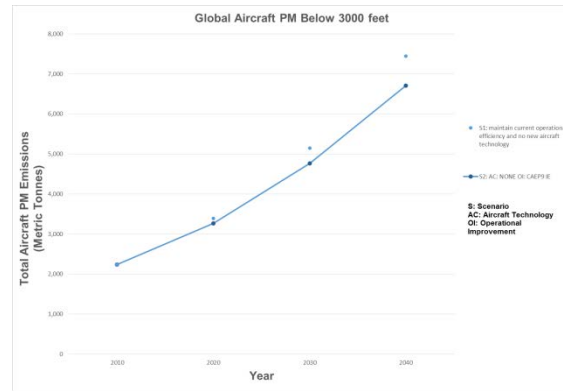

Figure 1.3. Total Global Aircraft PM Emissions Below 3,000 Feet Above Ground Level

1.1.4 Aircraft Emissions that affect the Global Climate

1.1.4.1 Trends for emissions that affect the global climate include full-flight NO_x, fuel burn and CO₂ emissions. NO_x and fuel burn trends results, as well as the definitions of the scenarios considered are provided in Appendix A.

1.1.4.2 Information regarding the possible contribution of alternative fuels toward reducing net life cycle CO₂ emissions from international aviation was developed by AFTF as discussed under Agenda Item 8. Figure 1.4 presents the updated CO₂ trends assessment which incorporates this information on alternative fuels.

1.1.4.3 For 2020, 12 scenarios were considered, which provide up to 2 percent petroleum-based fuel replacement and up to 1.2 percent GHG emissions reductions. For 2050, AFTF calculated 120 combinations of production achievement and GHG emissions scenarios. Several of the 2050 scenarios that AFTF evaluated resulted in zero alternative jet fuel production and therefore no contribution to GHG emissions reduction. The scenario with the greatest contribution to GHG emissions reduction could supply more alternative jet fuel than is anticipated to be required in 2050. For the purposes of this analysis, production for the highest contribution scenario is ramped up to full replacement in 2050 based on Scenario 9 for technology and operational improvements. Additional information is presented in Appendix A.

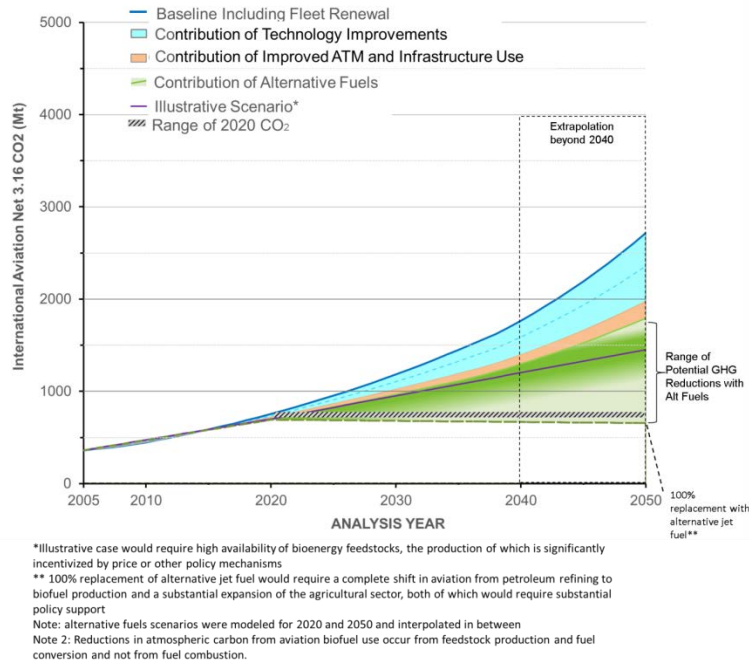

Figure 1.4. Aircraft CO₂ Emissions from International Aviation, 2005 to 2050, Updated to Include Alternative Fuels Life Cycle Emissions Reductions.

Discussion and Conclusions

1.1.5 For the noise trends, the meeting noted that for the advanced technology and operational improvement scenarios, after 2030 an increase in operations will no longer reflect an increase in noise contour area, to which the Secretariat noted this could be considered “noise neutral growth”. The MDG co-Rapporteur indicated that it is possible based on an average noise metric (DNL) and only for the most aggressive technology and operational improvement scenario. In response to a question, it was explained that additional input data and analysis would be required to understand the effect that specialized procedures, such as through the use of Performance Based Navigation (PBN), might have on contour shapes and areas.

1.1.6 In reviewing the PM trends, the MDG co-Rapporteur explained that as more information on PM emissions become available, it will be possible to coordinate with WG3 to include PM technology improvements in the trends. For NO_x results, moderate and advanced fuel burn technologies were included among the scenarios. A member recommended that the meeting agreed that the PM trends should be presented to the Council, but that no additional PM trends should be developed until data becomes available as a result of the new nvPM Standard being recommended for Annex 16, Volume II.

1.1.7 The meeting noted that as shown in Figure 15 of Appendix A, in the near term (2010 to 2020), efficiency improvements from technology and improved ATM and infrastructure use are expected to be moderate, and they are projected to accelerate in the mid-term (2020 to 2030). During the 2020 to 2030 period, fuel efficiency is expected to improve at an average rate of 1.76 per cent per annum under the most advanced technological and operational improvement scenario considered by MDG. This analysis shows that additional technological and operational improvements beyond even those evaluated will be required to achieve the global aspirational goal of 2 per cent per annum fuel efficiency.

1.1.8 The Secretariat highlighted that a review of fuel sales data from IEA compared with RTK collected by ICAO has shown an average annual fuel efficiency improvement for global aviation of 3 per cent per annum for the period 1996 to 2013. The MDG co-Rapporteur also explained the sensitivity to

the fuel burn results on the forecast, recalling that the uncertainty in those results from the use of the low, central, or high CAEP/9 forecast is greater than from the operational and technology improvement assumptions.

1.1.9 The Secretariat also highlighted the importance of work on long term goals and the need to develop studies that would consider the 2°C budget and the share of international aviation emissions in such a budget. A member proposed tasking ISG, AFTF, MDG to scope work for putting international aviation emissions into the context of a 1,000 Gt emissions budget (1.5/2°C scenario) for a further discussion during the 2016 CAEP Steering Group meeting.

1.1.10 In light of this information, the meeting underscored that the value of the CAEP trends assessment is that they are a consensus that reflects collaboration from all the working groups and that they represent a common view among all members and observers. A member highlighted the risk of misinterpretation of the graphs presenting alternative fuels trends. The meeting agreed that additional documentation to support the trends and the way they are presented is needed prior to April 2016 for review by the Council. The meeting also agreed that additional support be provided to Secretariat on how to communicate the trends.

1.1.11 The meeting congratulated MDG and AFTF on the update to the trends assessment finding that they provide a valuable source of information regarding the future evolution of aircraft noise and emissions.

1.1.12 An observer presented a review of recent studies regarding an emissions reduction for international aviation out to 2050 that would contribute to preventing global average warming above 1.5/2°C. The meeting noted the information and will consider it in the context of updates to the trends assessment and feasibility of goals work during the discussion on future work.

1.1.13 The meeting was reminded that Assembly Resolution A38-14 requested the Council to “to develop one single set of long-term traffic forecast, from which customized or more detailed forecasts can be produced for various purposes, such as air navigation systems planning and environmental analysis.” This work is being carried out by the Aviation Data and Analysis Panel (ADAP), through the Multi-Disciplinary Working Group on a Long Term Forecast (MDWG-LTF).

1.1.14 The MDWG-LTF has identified 40 international and 10 domestic route groups for the updated forecast and has built a forecasting model around historic data for the period 1995 to 2012 for those route groups.

1.1.15 ADAP is planning to present its draft forecast to CAEP in April 2016 concurrent with its initial presentation to Council. FESG proposed working from that version of the ICAO forecast to begin developing fleet and business jet forecasts. This would allow for a progress report to be presented to the 2016 CAEP Steering Group meeting and for a final set of CAEP tailored forecasts to be made available to MDG in January/February 2017.

1.1.16 The meeting asked ADAP to work with WG3, MDG, FESG to build a comprehensive schedule that details the interactions between those groups so that all of the elements necessary are available to support a PM stringency analysis during CAEP/11. The meeting requested that the schedule be presented in a format similar to what was developed for the CO₂ Standard. The meeting stressed that the updated forecast will be in the critical path for this work.

1.1.17 In response to a question, it was explained that initially the ICAO forecast is being developed with resources from the United States and the ICAO Secretariat. The results will first be

reviewed by the MDWG-LTF and then by the broader ADAP. The meeting underscored that a sound validation process is essential to ensure the reusability and consistency with CAEP modelling work and for understanding the assumptions which will drive CAEP conclusions.

1.1.18 **Recommendation**

1.1.18.1 In light of the discussions the following recommendation was developed:

Recommendation 1/1 — Endorsement of the global environmental trends assessments

That Council consider that the global environmental trends should be used as the basis of decision-making on noise and emissions discussions by the 39th Session of the ICAO Assembly, and should be continually reviewed by CAEP.

— — — — —

APPENDIX A (English only)

1. AIRCRAFT NOISE TRENDS

1.1 Models and Databases

1.1.1 Three models contributed results to the CAEP/10 noise trends assessment: US FAA's Aviation Environmental Design Tool (AEDT); EUROCONTROL/European Aviation Safety Agency's (EASA) SysTem for AirPort noise Exposure Studies (STAPES); and U.K. Civil Aviation Authority's (CAA) Aircraft Noise Contour Model (ANCON).

1.1.2 The following population databases were used in this analysis:

- US airports used US Census 2010.
- UK airports used UK National Census (2011).
- Mainland European airports used EEA Census (year varies by country).
- For Rest of the World (ROW) airports, those not covered by the above databases, a new Population source was introduced (Landscan Version 2011) in addition to Grump Version 2000, as used in CAEP/8/9 Noise Trends Assessment.

1.2 Scenario Definitions

1.2.1 MDG has modelled aircraft noise for 4 scenarios.

1.2.1.1 **Scenario 1 (*Baseline*)**: This scenario includes the operational improvements necessary to maintain current efficiency levels and does not include any technology improvements beyond those available in current production and project (i.e. identified as in-development) aircraft.

1.2.1.2 **Scenario 2 (*Low Aircraft Technology and Moderate Operational Improvement*)**: This scenario includes noise technology improvements of 0.3 EPNdB per annum for all aircraft entering the fleet from 2011 to 2013 and 0.1 EPNdB per annum for all aircraft entering the fleet from 2014 to 2050 and additional fleet-wide moderate operational improvements of 2% for population inside DNL 55, 60, and 65 contours. Operational improvements are only likely to change the shape of the contour, not the overall size.

1.2.1.3 **Scenario 3 (*Moderate Aircraft Technology and Operational Improvement*)**: This scenario includes noise improvements of 0.3 EPNdB per annum for all aircraft entering the fleet from 2011 to 2030, 0.1 EPNdB from 2031 to 2050 and additional fleet-wide moderate operational improvements of 2% for population inside DNL 55, 60, and 65 contours. Operational improvements are only likely to change the shape of the contour, not the overall size.

1.2.1.4 **Scenario 4 (*Advanced Aircraft Technology and Moderate Operational Improvement*)**: This scenario includes noise improvements of 0.3 EPNdB per annum for all aircraft entering the fleet from 2011 to 2050 and additional fleet-wide moderate operational improvements of 2% for population

inside DNL 55, 60, and 65 contours. Operational improvements are only likely to change the shape of the contour, not the overall size.

1.3 Reporting of Results

1.3.1 For Rest of the World airports (168 out of 321) two different population sources were used (legacy GRUMP and the newer LANDSCAN). Comparisons between GRUMP/LANDSCAN and census sources from the US, UK and Mainland Europe yielded mixed results, with some airports having higher and some lower population counts. Consequently, MDG agreed to present the population results as a range, showing both low and high values.

1.3.2 Figure 1 provides results for the total global contour area (i.e. for 321 airports) from aircraft noise above 55 DNL for 2010, 2020, 2030 and 2040 for the four scenarios. The 2010 baseline value is 13,975 square km. In 2040, total global contour area ranges from 16,189 square km with Scenario 4 to about 22,449 square km with Scenario 2. As is seen in Figure 1, under the advanced technology scenario, “peak DNL” may be reached in 2030 in terms of contour area, meaning that beyond that time, the projected increase in aircraft operations will no longer result in an increase in noise contour area.

1.3.3 Figure 2 provides results for the total global population exposed to aircraft noise above 55 DNL for 2010, 2020, 2030 and 2040 for the four scenarios. The 2010 baseline value ranges from 22.0 to 36.4 million people. In 2040, total population exposed ranges from about 27.8 to 46.1 million people with Scenario 4, to about 39.8 to 64.2 million people with Scenario 2.

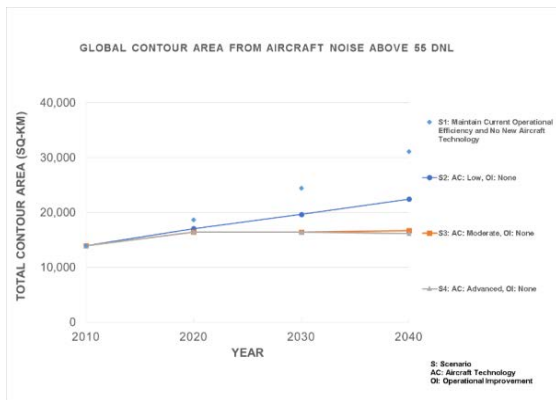

Figure 1. Global Contour Area from Aircraft Noise above 55 DNL.

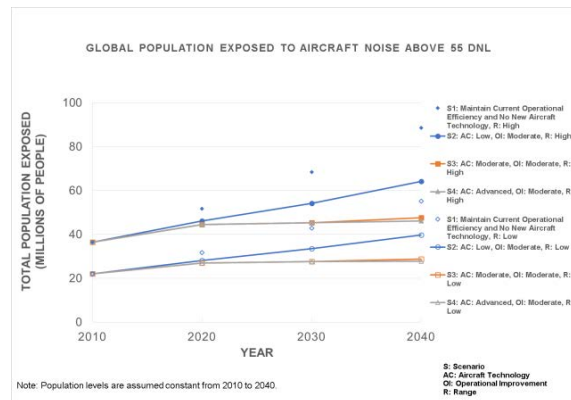

Figure 2. Global Population Exposed to Aircraft Noise above 55 DNL.

1.3.4 Figures 3 and 4 provide results for the total global contour area from aircraft noise and total global population exposed to aircraft noise above 60 DNL for 2010, 2020, 2030 and 2040 for the four scenarios. Figures 5 and 6 provides results for the total global contour area from aircraft noise and total global population exposed to aircraft noise above 65 DNL for 2010, 2020, 2030 and 2040 for the four scenarios.

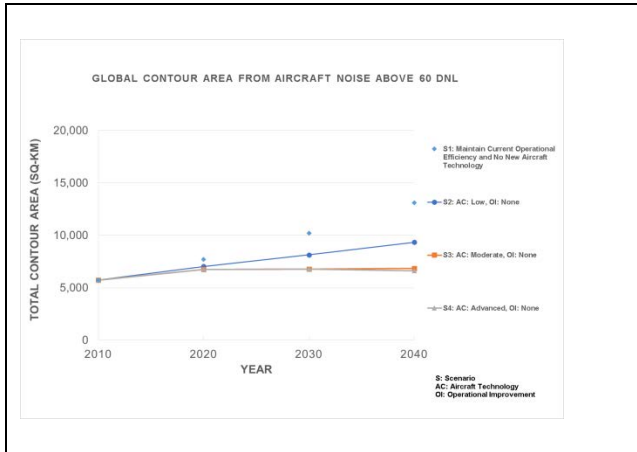

Figure 3. Global Contour Area from Aircraft Noise above 60 DNL.

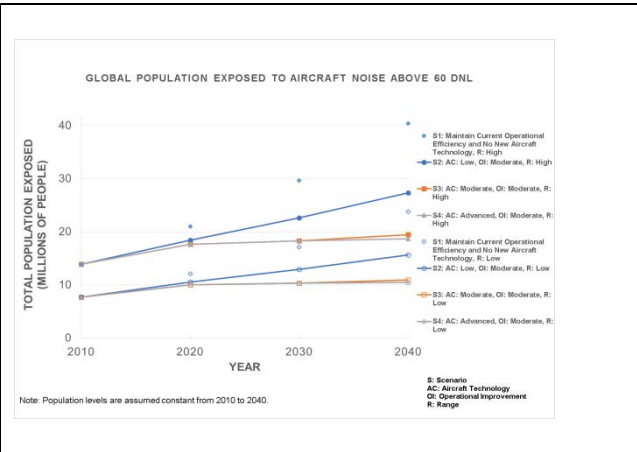

Figure 4. Global Population Exposed to Aircraft Noise above 60 DNL.

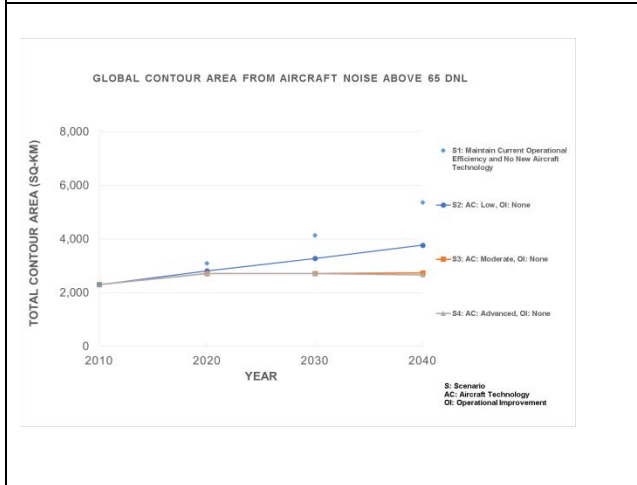

Figure 5. Global Contour Area from Aircraft Noise above 65 DNL.

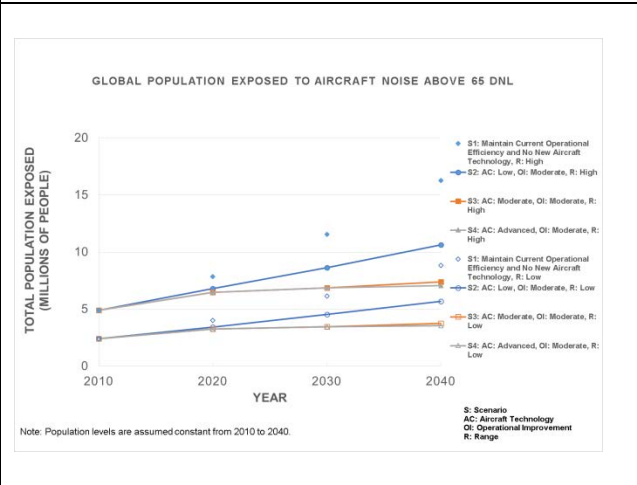

Figure 6. Global Population Exposed to Aircraft Noise above 65 DNL.

1.3.5 Figures 7 and 8 provide total global contour area (normalized to 2010 values) and population exposed from aircraft noise above 60 DNL, respectively.

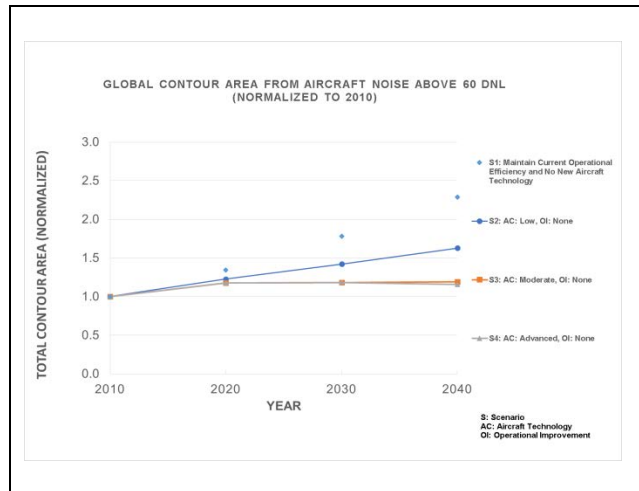

Figure 7. Global Contour Area from Aircraft Noise above 60 DNL (Normalized to 2010).

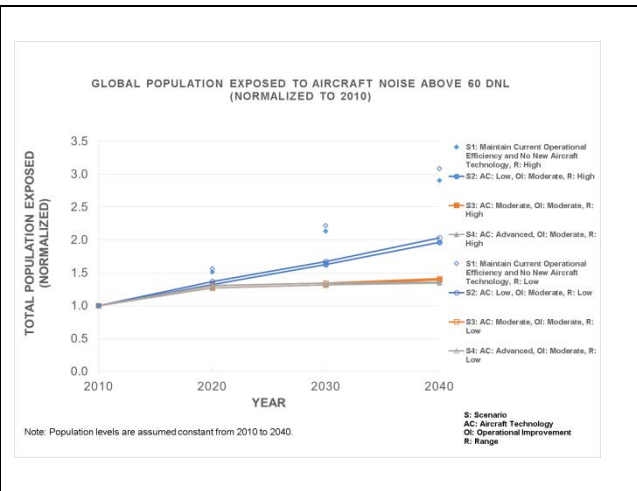

Figure 8. Global Population Exposed to Aircraft Noise above 60 DNL (Normalized to 2010).

1.3.6 Figures 9 and 10 provide total global contour area (normalized to 2010 values) and population exposed from aircraft noise above 65 DNL, respectively.

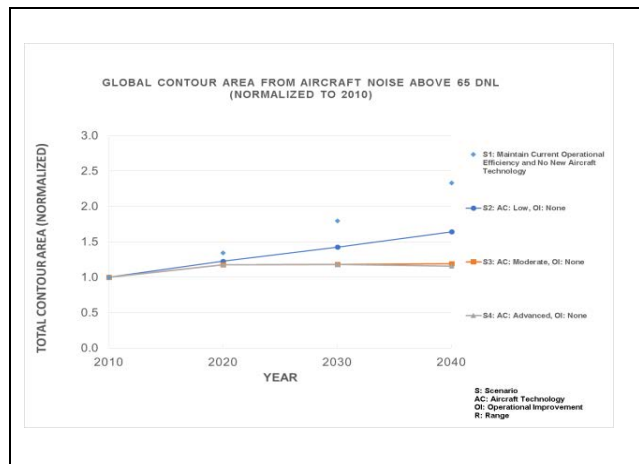

Figure 9. Global Contour Area from Aircraft Noise above 65 DNL (Normalized to 2010).

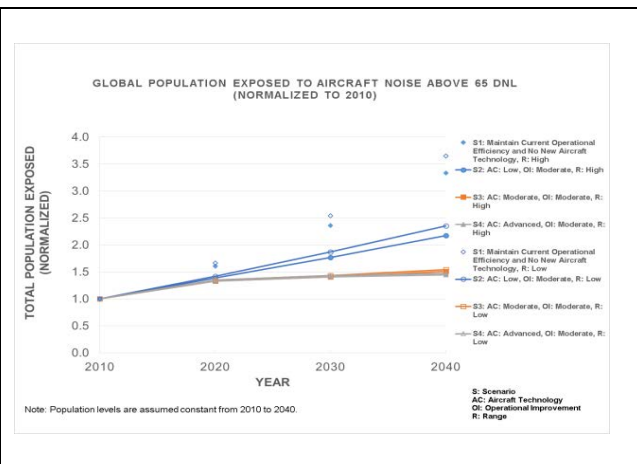

Figure 10. Global Population Exposed to Aircraft Noise above 65 DNL (Normalized to 2010).

2. AIRCRAFT ENGINE EMISSIONS TRENDS THAT AFFECT LOCAL AIR QUALITY

2.1 Models and Databases

2.1.1 Two models contributed results to the CAEP/10 LAQ trends assessment: US FAA’s Aviation Environmental Design Tool (AEDT); and EUROCONTROL’s IMPACT. Both models use performance based flight profiles to compute emissions below 3,000 feet above ground level, which is within the landing and takeoff (LTO) cycle. ICAO Default Taxi times of 26 minutes and ICAO Engine Exhaust Emissions Databank fuel flow are used for taxi portions of the flight.

2.2 Modelling Assumptions

LTO NOx (Scenarios 1 – 3)

2.2.1.1 **Scenario 1** is a sensitivity case and maintains current operational efficiency and no new aircraft technology.

2.2.1.2 **Scenario 2** is the moderate aircraft technology and CAEP/9 IE Operational Improvement case that assumes aircraft NOx improvement based upon achieving 50 percent of the reduction from current NOx Emission levels to the NOx Emissions levels by CAEP/7 NOx Independent Expert goals review (-60 percent +/- 5 percent of current CAEP/6 NOx Standard) for 2026, with no further improvement thereafter. It also includes additional fleet-wide operational improvements by route group.

2.2.1.3 **Scenario 3** is the advanced aircraft technology and CAEP/9 IE Operational Improvement case that assumes aircraft NOx improvement based upon achieving 100 percent of the reduction from current NOx Emission levels to the NOx Emissions levels by CAEP/7 NOx Independent Expert goals review (-60 percent +/- 5 percent of current CAEP/6 NOx Standard) for 2026, with no further improvement thereafter. It also includes additional fleet-wide operational improvements by route group.

LTO PM (Scenarios 1 – 2)

2.2.1.4 **Scenario 1** is a sensitivity case and maintains current operational efficiency and no new aircraft technology.

2.2.1.5 **Scenario 2** is the no new aircraft technology and CAEP/9 IE Operational Improvement case. Aircraft technology is held constant, but fleet-wide operational improvements by route group are included, as provided in Table 1.

2.3 Results

NOx Emissions within the LTO Cycle (below 3000 feet)

2.3.1.1 Figure 11 provides MDG results for the global aircraft NOx below 3,000 feet. 2010 baseline value is 0.30MT. In 2040 NOx below 3000 feet value ranges from 0.65 MT in Scenario 3 to 0.86 MT in Scenario 2. In comparisons, in CAEP/8/9 Trends, 2006 baseline value was 0.25 MT and in 2036 NOx ranges from 0.52 MT with Scenario 3 to 0.72 MT with Scenario 2.

2.3.1.2 Figure 12 provides MDG results for the international aircraft NOx below 3000 feet. 2010 baseline value is 0.15MT. In 2040 NOx below 3,000 feet value ranges from 0.32 MT in Scenario 3 to 0.42 MT in Scenario 2.

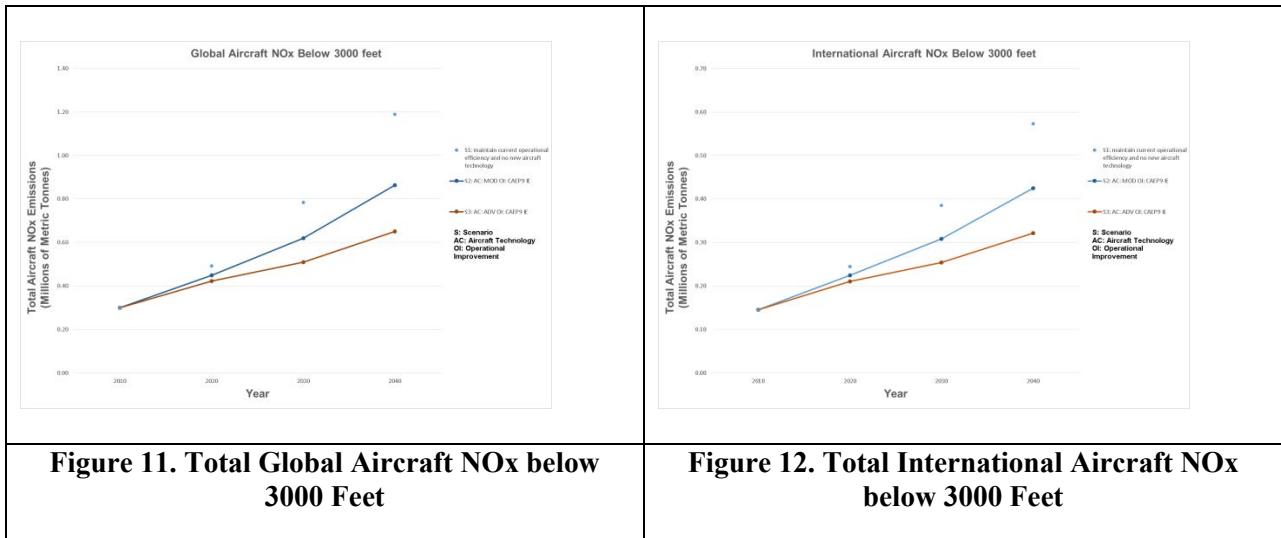

PM Emissions within the LTO Cycle (below 3000 feet)

2.3.1.3 It is important to note that NOx emissions results were presented in units of mega-tonnes, which are millions of metric tonnes. PM emissions are presented in terms of tonnes, a metric 1,000,000 times smaller mass than the one used for NOx emissions. Figure 13 provides MDG results for the global aircraft PM below 3000 feet. 2010 baseline value is 2,239 Metric Tonnes. In 2040 global aircraft PM below 3,000 feet emissions are 6,709 Metric Tonnes under Scenario 2. In comparison with CAEP/8/9 Trends, the 2006 baseline value was 2,200 Metric Tonnes and in 2036 the value was projected to be 5,800 Metric Tonnes.

2.3.1.4 Figure 14 provides MDG results for the international aircraft PM emissions below 3,000 feet. The 2010 baseline value is 914 Metric Tonnes. In 2040 international aircraft PM emissions below 3,000 feet value is 3003 Metric Tonnes with Scenario 2.

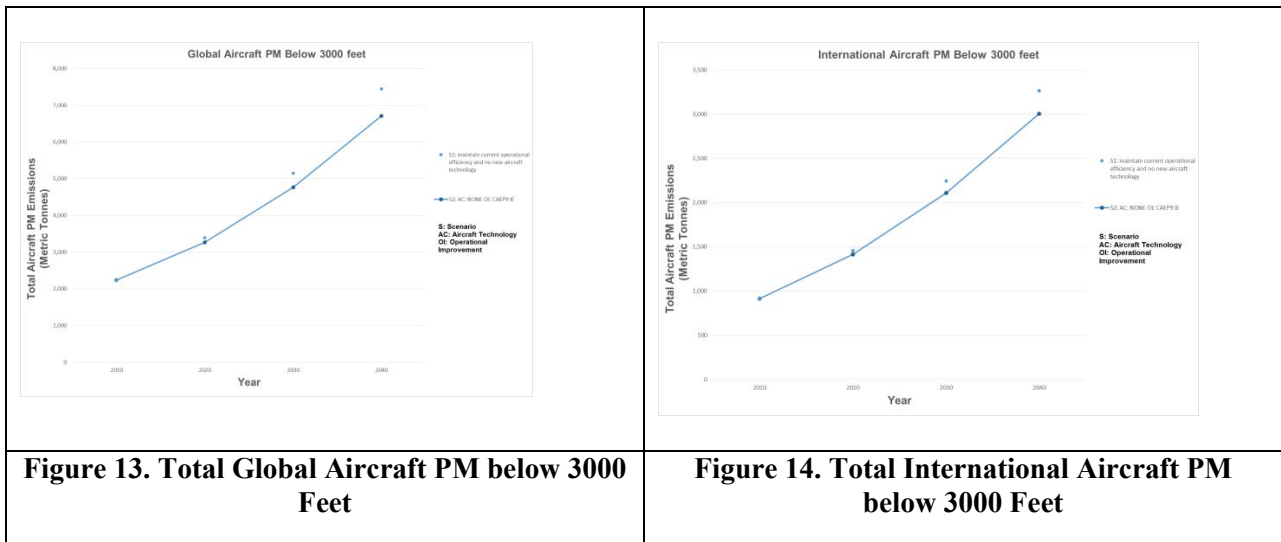

3. AIRCRAFT EMISSIONS THAT AFFECT THE GLOBAL CLIMATE

3.1 Analysis Assumptions

3.1.1 A total of nine scenarios were modelled to illustrate the range of possible technological and operational improvements. The results are based on the CAEP central demand forecast that used a base year of 2010. Data presented for 2005 and 2006 were reproduced from the trends assessment presented to the 37th Session of the ICAO Assembly.

3.1.2 Three models contributed results to the trends assessment: FAA's Aviation Environmental Design Tool (AEDT); EUROCONTROL's Advanced Emissions Model (AEM); and Manchester Metropolitan University's Future Civil Aviation Scenario Software Tool (FAST).

Technology and Operations Scenarios

1.1.1.1 **Scenario 1 (Baseline):** This scenario includes the operational improvements necessary to maintain 2010 operational efficiency levels, but does not include any technology improvements beyond those available in 2010 production aircraft.

1.1.1.2 **Scenario 2 (Low Aircraft Technology and Moderate Operational Improvement):** In addition to including the improvements associated with the migration to the latest operational initiatives, e.g., those planned in NextGen and SESAR, this scenario includes fuel burn improvements of 0.96 per cent per annum for all aircraft entering the fleet after 2010 and prior to 2015, and 0.57 per cent per annum for all aircraft entering the fleet beginning in 2015 out to 2050. It also includes additional fleet-wide moderate operational improvements by region, as provided in Table 1 under "lower bound."

1.1.1.3 **Scenario 3 (Moderate Aircraft Technology and Operational Improvement):** In addition to including the improvements associated with the migration to the latest operational initiatives, e.g., those planned in NextGen and SESAR, this scenario includes fuel burn improvements of 0.96 per cent per annum for all aircraft entering the fleet after 2010 out to 2050. It also includes additional fleet-wide moderate operational improvements by region, as provided in Table 1 under "lower bound."

1.1.1.4 **Scenario 4 (Advanced Aircraft Technology and Operational Improvement):** In addition to including the improvements associated with the migration to the latest operational initiatives, e.g., those planned in NextGen and SESAR, this scenario includes fuel burn improvements of 1.16 per cent per annum for all aircraft entering the fleet after 2010 out to 2050. It also includes additional fleet-wide advanced operational improvements by region, as provided in Table 1 under "upper bound."

1.1.1.5 **Scenario 5 (Optimistic Aircraft Technology and Advanced Operational Improvement):** In addition to including the improvements associated with the migration to the latest operational initiatives, e.g., those planned in NextGen and SESAR, this scenario includes an optimistic fuel burn improvement of 1.5 per cent per annum for all aircraft entering the fleet after 2010 out to 2050. It also includes additional fleet-wide advanced operational improvements by region, as provided in Table 1 under "upper bound." This scenario goes beyond the improvements based on industry-based recommendations.

1.1.1.6 **Scenario 6 (Low Aircraft Technology and CAEP/9 Independent Expert (IE) Operational Improvement):** This scenario includes fuel burn improvements of 0.96 per cent per annum for all aircraft entering the fleet after 2010 and prior to 2015, and 0.57 per cent per annum for all aircraft

entering the fleet beginning in 2015 out to 2050. It also includes additional fleet-wide CAEP/9 independent expert (IE) Operational Improvements by route group, as provided in Table 2.

1.1.1.7 **Scenario 7 (*Moderate Aircraft Technology and CAEP/9 IE Operational Improvement*)**: In addition to including the improvements associated with the migration to the latest operational initiatives, e.g., those planned in NextGen and SESAR, this scenario includes fuel burn improvements of 0.96 per cent per annum for all aircraft entering the fleet after 2010 out to 2050. It also includes additional fleet-wide CAEP/9 IE Operational Improvements by route group, as provided in Table 2.

1.1.1.8 **Scenario 8 (*Advanced Aircraft Technology and CAEP/9 IE Operational Improvement*)**: In addition to including the improvements associated with the migration to the latest operational initiatives, e.g., those planned in NextGen and SESAR, this scenario includes fuel burn improvements of 1.16 per cent per annum for all aircraft entering the fleet after 2010 out to 2050. It also includes additional fleet-wide CAEP/9 IE Operational Improvements by route group, as provided in Table 2.

1.1.1.9 **Scenario 9 (*Optimistic Aircraft Technology and CAEP/9 IE Operational Improvement*)**: In addition to including the improvements associated with the migration to the latest operational initiatives, e.g., those planned in NextGen and SESAR, this scenario includes an optimistic fuel burn improvement of 1.5 per cent per annum for all aircraft entering the fleet after 2010 out to 2050. It also includes additional fleet-wide CAEP/9 IE Operational Improvements by route group, as provided in Table 2. This scenario goes beyond the improvements based on industry-based recommendations.

Table 1. Per Cent Change in gate-to-gate fuel burn relative to 2010, by Region

	2020		2030/2040/2050	
	Lower Bound	Upper Bound	Lower Bound	Upper Bound
North America	0	-2	0	-4
Europe	-2	-6	-3	-7
Central America	-1	-4	-2	-5
South America	-1	-4	-2	-5
Middle East	-2	-5	-3	-6
Africa	-4	-7	-5	-8
Asia/Pacific	-3	-6	-4	-7

Table 2. Per Cent Change in gate-to-gate fuel burn relative to 2010, by Route Group

Route Group	2020 Goal	2030 Goal	2040 Goal
Domestic Africa	3.13%	6.59%	9.95%
Domestic Asia/Pacific	4.01%	8.70%	11.53%
Domestic Europe	4.35%	8.28%	11.30%
Domestic Latin America	3.33%	7.46%	10.38%
Domestic Middle East	4.00%	8.98%	11.71%
Domestic North America	4.73%	8.98%	11.41%
Europe – Africa	2.38%	5.26%	7.55%
Europe - Asia/Pacific	2.27%	4.94%	6.26%
Europe - Middle East	1.67%	4.46%	6.86%
Intra Africa	2.50%	5.24%	8.09%
Intra Asia/Pacific	2.82%	6.12%	7.82%
Intra Europe	3.41%	6.63%	9.23%
Intra Latin America	2.96%	6.83%	9.39%
Intra Middle East	3.50%	7.88%	10.26%
Intra North America	4.73%	9.27%	12.05%
Mid Atlantic	2.30%	4.90%	6.08%
Middle East - Asia/Pacific	2.46%	5.35%	6.72%
N America – Cen America/Caribbean	3.19%	6.73%	9.01%
North America - South America	2.24%	5.31%	7.15%
North Atlantic	2.33%	4.93%	6.11%
Other International Routes	2.63%	6.18%	8.42%
South Atlantic	2.12%	4.64%	5.78%
Transpacific	2.10%	4.61%	5.76%

3.2 Trends in Aircraft Fuel Burn

3.2.1 Figure 15 provides results for global full-flight fuel burn for international aviation from 2005 to 2040, and then extrapolated to 2050. The fuel burn analysis takes into account the contribution of aircraft technology, improved air traffic management and infrastructure use (i.e., operational improvements) to reduce fuel consumption. The figure also illustrates the fuel burn that would be expected if the 2 per cent annual fuel efficiency aspirational goal were achieved. Figure 16 puts these contributions in context with the uncertainty associated with the forecasted demand, which is notably larger than the range of potential contributions from technological and operational improvements.

3.2.2 The results presented in Figures 15 and 16 are for international aviation only. In 2010, approximately 65 per cent of global aviation fuel consumption was from international aviation. Based on CAEP's analysis, this proportion is expected to grow to nearly 70 per cent by 2050.

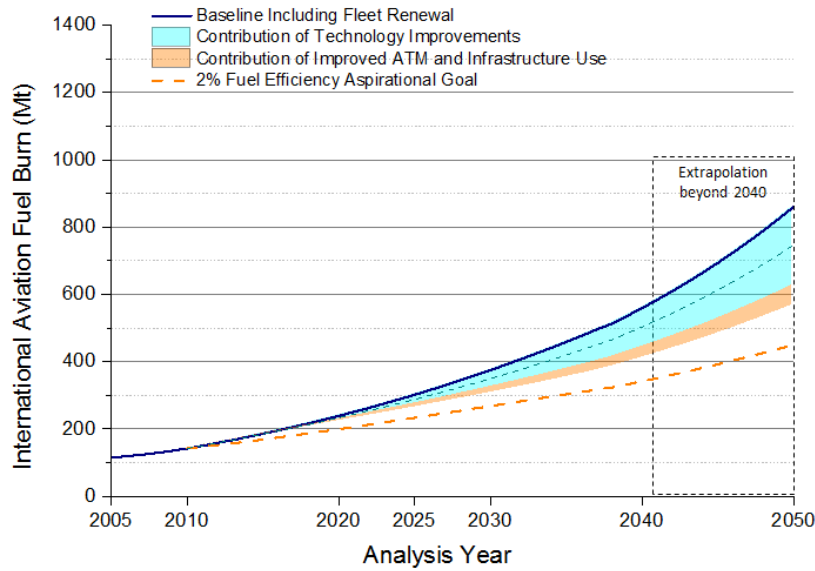

*Dashed line in technology contribution sliver represents the "Low Aircraft Technology Scenario."
 Note: Results were modelled for 2005, 2006, 2010, 2020, 2025, 2030, and 2040 then extrapolated to 2050.

Figure 15. Aircraft Fuel Burn from International Aviation, 2005 to 2050.

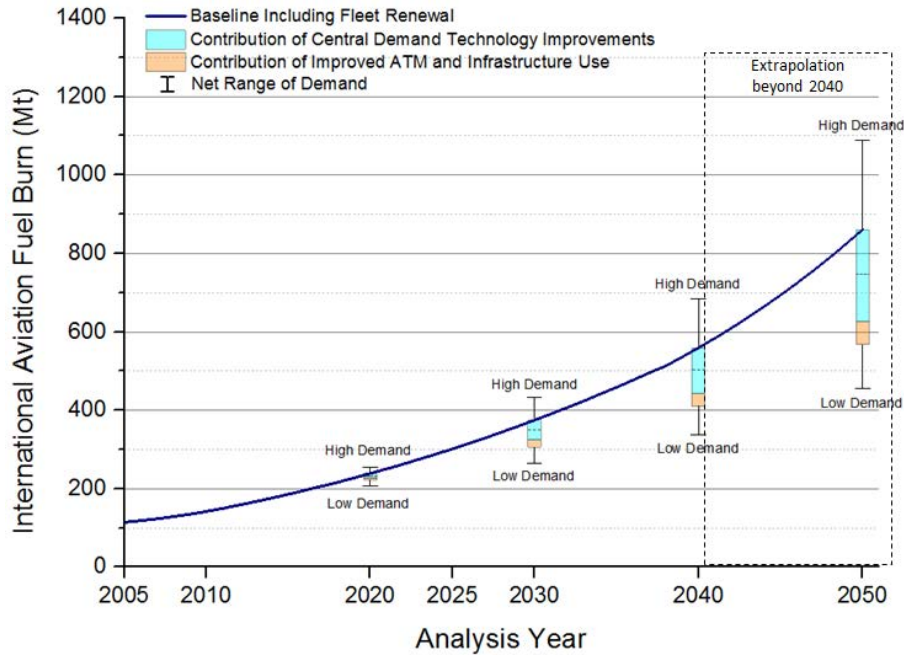

Note: Fuel burn was only modelled for the central demand forecast. The effects of the high and low demand sensitivities shown are based on the ratio of forecasted revenue passenger kilometres for high/low demand relative to central demand.

Figure 16. Range of Uncertainties Associated with Demand Forecast, 2005 to 2050.

3.3 Trends in Aircraft CO₂ Emissions

3.3.1 Figure 17 presents full-flight CO₂ emissions for international aviation from 2005 to 2040, and then extrapolated to 2050. This figure only takes into the account the CO₂ emissions associated with

the combustion of jet fuel, assuming that 1 kg of jet fuel burned generates 3.16 kg of CO₂. As with the fuel burn analysis, this analysis takes into account the contribution of aircraft technology, improved air traffic management and infrastructure use (i.e., operational improvements). In addition the range of possible CO₂ emissions in 2020 are displayed for reference to the global aspirational goal of keeping the net CO₂ emissions at this level. Although, not displayed in a separate figure, the demand uncertainty effect on the fuel burn calculations shown in Figure 16 has an identical effect on the CO₂ results.

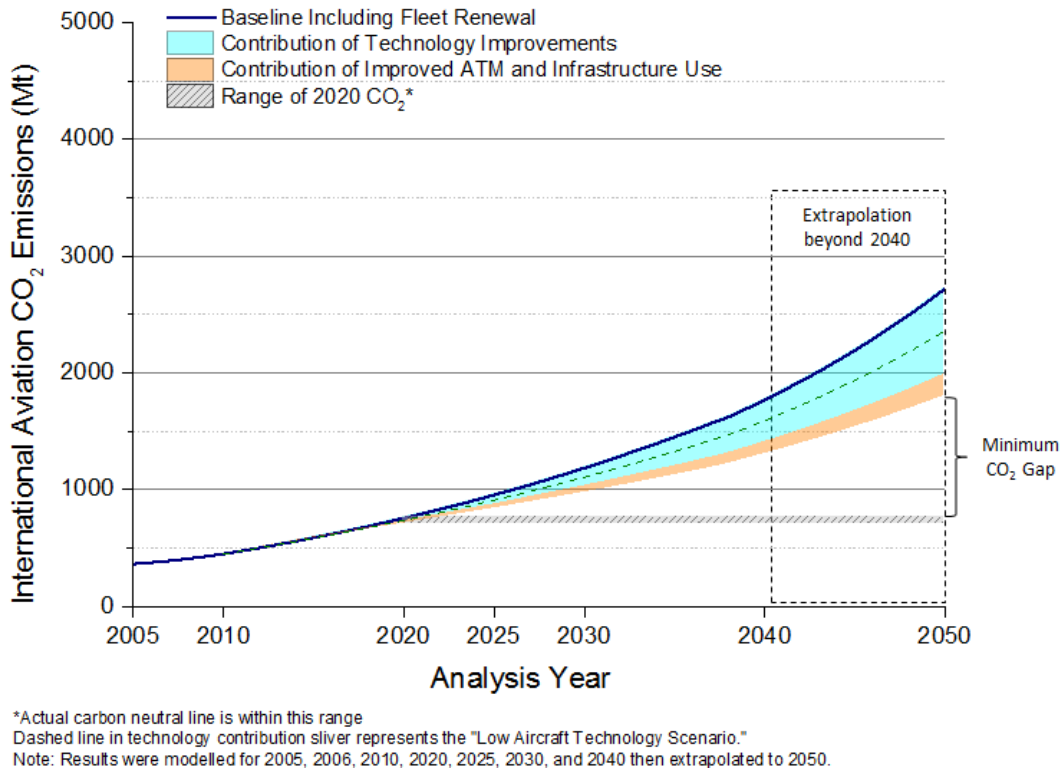

Figure 17. Aircraft CO₂ Emissions from International Aviation Reflecting Aircraft Technology, Air Traffic Management and Infrastructure Use Improvements Only, 2005 to 2050.

3.4 Consideration of Sustainable Alternative Fuels

3.4.1 AFTF performed analyses for 2020 and 2050. The final values provided by AFTF to MDG include total global production and an average LCA value based on the share of different fuel types that contribute to each scenario. The LCA values are not intended to be applied separately to regional forecasts. Additional detail regarding the alternative fuels scenarios is provided in paragraph 3.5.

3.4.2 For 2020, six production estimates and two GHG LCA estimates (low and high), resulting in 12 possible GHG emissions scenarios that were used. The 2020 scenarios provide up to 2 percent petroleum-based fuel replacement and up to 1.2 percent GHG emissions reductions.

3.4.3 For 2050, AFTF calculated 60 production achievement scenarios and two GHG emissions scenarios resulting in 120 scenarios. Certain global conditions, economic investments, and policy decisions are assumed as part of each scenario definition and would be necessary to reach the associated outcome of alternative fuel production and GHG reductions.

3.4.4 The Trends Assessment update for international aviation shows the range of results from AFTF as well as an “illustrative” scenario as presented in Figure 18. Fuel replacement results can be found in Figure 19. The amount of alternative jet fuel and the associated GHG emissions reductions were allocated proportionally between international and domestic use based on projected fuel demand.

3.4.5 Several of the 2050 scenarios that AFTF evaluated resulted in zero alternative jet fuel production and therefore no contribution to GHG emissions reduction.¹ The results are equivalent to the line associated with Scenario 9 for technology and operational improvements.

3.4.6 The scenario with the greatest contribution to GHG emissions reduction could supply more alternative jet fuel than is anticipated to be required in 2050. For the purposes of this analysis, production for the highest contribution scenario is ramped up to full replacement in 2050 based on MDG Scenario 9.

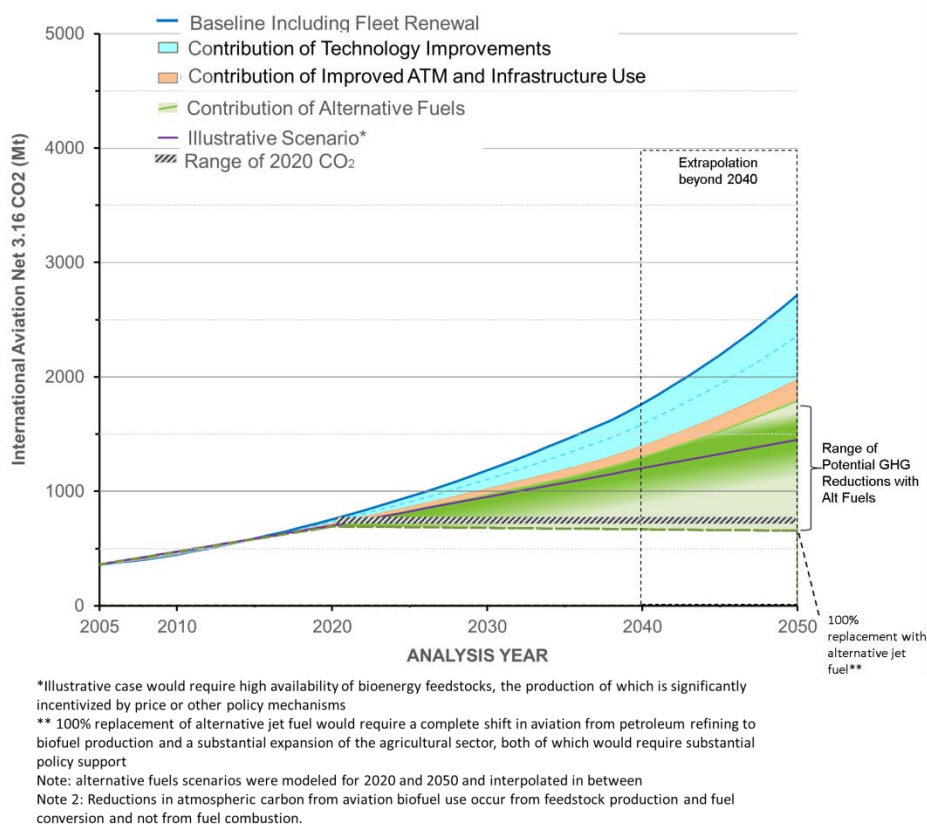
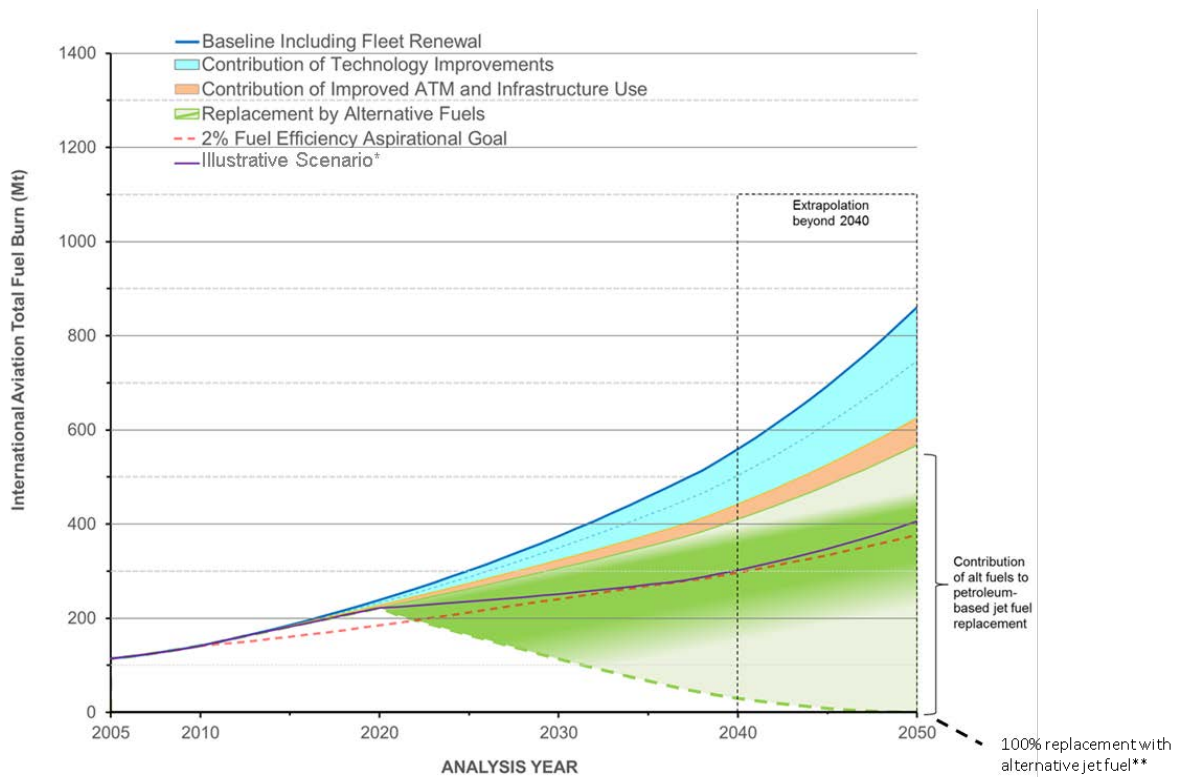

Figure 18. Aircraft CO₂ Emissions from International Aviation, 2005 to 2050, Updated to Include Alternative Fuels Life Cycle Emissions Reductions.

¹ These scenarios reflect a lack of bioenergy availability in general or a prioritization of other bioenergy usages over aviation.



*Illustrative case would require high availability of bioenergy feedstocks, the production of which is significantly incentivized by price or other policy mechanisms
 ** 100% replacement of alternative jet fuel would require a complete shift in aviation from petroleum refining to biofuel production and a substantial expansion of the agricultural sector, both of which would require substantial policy support
 Note: alternative fuels scenarios were modeled for 2020 and 2050 and interpolated in between
 Note 2: alternative fuel increase appears curved due to subtraction of linear ramp up from Scenario 9 growth curve.

Figure 19. Aircraft Fuel Burn from International Aviation, 2005 to 2050 Updated to Include Potential Replacement of Jet Fuel with Alternative Fuels.

3.4.7 An “illustrative” scenario providing a 19% reduction in GHG emissions was identified by AFTF to describe the conditions under which the selected level of GHG emissions reductions could be achieved via the use of alternative jet fuels.

3.4.8 For 2020 and 2050, total petroleum-based fuel amounts for the different fuel demand scenarios were multiplied by the specific CO₂ combustion emissions factor of 3.16 to get baseline GHG emissions. Calculations of GHG emissions reduction were performed according to the following formula provided by the AFTF.

- $Total\ Emissions = 3.16 \times (CJF + AJF \times (LCA_{AJF} / LCA_{CJF}))$, where CJF = conventional jet fuel, AJF = alternative jet fuel, and LCA_X = life cycle CO₂ equivalent emissions of fuel X.²

3.4.9 The GHG reduction “wedge” was created by connecting the least contribution scenario values to each other and the greatest contribution values to each other. The 2020 “medium scenario

² This calculation provides an “in-flight” equivalent of CO₂ emissions reduction based on the life cycle values of the alternative fuels, which are used because reductions in atmospheric carbon from aviation biofuel use occur from feedstock production and fuel conversion and not from fuel combustion

without green diesel” was connected to the 2050 value for the illustrative scenario. MDG elected to show linear growth for intermediate and high GHG reduction scenarios.³

3.4.10 Achievement of carbon neutral growth at 2020 emissions levels out to 2050 would require strong incentives for production of feedstocks and alternative jet fuels throughout the supply chain.

3.5 Alternative Fuels Scenarios

3.5.1 To achieve significant reduction in aviation GHG emissions by 2050, high capital investments are required and these are likely to be feasible only if the investments begin immediately and consistently grow over time, or if existing infrastructure can be leveraged to reduce the required capital investments.

3.5.2 A “low” reduction scenario achieving 2 percent GHG reduction would require global AJF production of about 20 Mt/yr. in 2050. Constant growth in global AJF production capacity between 2020 and 2050 would require approximately seven large biorefineries to be built annually, requiring capital investment ranging between \$1B-\$3B/yr. If production ramp-up occurred exponentially to 2050, fewer than 5 refineries would have to be built annually in the early 2020s, while 15-20 new biorefineries would have to be constructed annually in the late 2040s. The required capital investment would be approximately less than US\$1B/yr. to US\$2B/yr. in 2025 and US\$2B-US\$7B/yr. in 2050.

3.5.3 The “illustrative” scenario achieving 19 percent GHG reduction assumes high availability of bioenergy feedstocks, production of which is significantly incentivized by favourable markets or policy mechanisms. Under an assumption of constant growth in production capacity between 2020 and 2050, this scenario would require approximately 50 large biorefineries to be constructed annually. If growth in production capacity were to start low and increase over time, 150-200 large biorefineries would have to be built per year approaching 2050.

3.5.4 If enough alternative jet fuel were produced in 2050 to completely replace petroleum-derived jet fuel, it would reduce GHG emissions by 63 percent and could close up to 110 percent of the GHG emissions gap between 2020 emissions levels and the MDG Scenario 9 fuel burn projection (it fills 110% of the “wedge” or “gap” between 2020 and 2050 GHG emissions levels). However, complete replacement would require approximately 170 new biorefineries to be built annually from 2020 to 2050, at an approximate cost of \$15B-\$60B/year if growth occurred linearly. If investment and growth began slowly and ramped up over time, over 500 new biorefineries would have to be constructed every year in the late 2040s, and almost 1000 new biorefineries would be required in 2050, requiring capital investments of \$1B-\$3B/yr. in 2025 and \$80B-\$340B/yr. in 2050. Achieving this level of emissions reduction would also require the realization of the highest assumed increases in agricultural productivity, highest availability of land for feedstock cultivation, highest residue removal rates, highest conversion efficiency improvements, largest reductions in the GHG emissions of utilities, as well as a strong market or policy emphasis on bioenergy in general, and alternative aviation fuel in particular. This implies that a large share of the globally available bioenergy resource would be devoted to producing aviation fuel, as opposed to other uses.

³ AFTF did not specify a function for connecting the 2020 results to the 2050 results in their outputs. AFTF anticipates that growth of a new industry such as that for AFJ will follow an “S-shaped” trajectory, but it is not clear when investment, and therefore, growth of production capacity of the industry, will ramp up. Ramp up to alternative fuel production in 2050 is anticipated to be somewhere between linear and exponential growth (i.e., the lower end of the S-curve). MDG elected to show linear growth for intermediate and high GHG reduction scenarios. No meaningful data exist in order to calibrate the curve. Therefore, values for intervening years between 2020 and 2050 for the alternative jet fuel scenarios should be considered illustrative only.

3.5.5 In the context of the MDG Trends Assessment, the AFTF results provide insight into the conditions necessary to achieve the aspirational goal of carbon neutral growth at 2020 emissions levels. These include strong incentives for production of feedstocks and alternative jet fuels, improvements in feedstock production and conversion efficiencies, large-scale use of wastes and residues, and prioritization of alternative jet fuel production over other uses of biomass and wastes.

3.5.6 The AFTF results applied to the MDG Trends Assessment show that it is unlikely carbon neutral growth can be accomplished by operational and technological improvements in conjunction with the expansion of AJF production unless complete or near-complete replacement of petroleum-based jet fuel is achieved, which would require a complete shift in aviation from petroleum refining to biofuel production and a substantial expansion of the agricultural sector, both of which would require substantial policy support.

Table 3. Summary of AFTF Scenarios Represented in MDG Trends Assessment.

AFJ contribution to aviation GHG mitigation	Scenario		AFJ production capacity in 2050 [Mt/yr.]	Number of biorefineries in 2050 ⁺	Estimated required conditions		
	Original AFTF Scenario Designation	Reduction of 2050 aviation GHG emissions*			Cumulative CapEx investment in biorefineries by 2050 [in billion 2015 USD]	Technology requirements	Policy requirements
Minimum (No Alternative Jet Fuel)	S3A1F4	0%	-	-	-		-
Low	S2A3F3	2%	20	200	\$20-\$70		
Illustrative	S3A1F3	19%	160	1400	\$100-\$500	- Improvements in fuel production efficiencies	- Bioenergy production incentivized by policies - Bioenergy resource allocation to all end-uses in proportion to share in final energy demands
Maximum (100% Jet Fuel Replacement)	S3A1F1	63%	570	5200	\$450-\$1800	- Highest agricultural yield growth rates and highest land availability - Highest agricultural and forestry residue removal rates - Improvements in fuel production efficiencies	- Bioenergy production strongly incentivized by policies - Alternative jet fuel production prioritized over all other uses of bioenergy

*Compared to MDG Scenario 9 fuel burn, assuming 100% petroleum-derived jet fuel
+ assuming 5000 barrels per day (bpd) facilities with a 50% jet fuel share at total output

3.6 Interpretation of Trends

3.6.1 In 2010, international aviation consumed approximately 142 million metric tonnes of fuel, resulting in 448 million metric tonnes (Mt, $1\text{ kg} \times 10^9$) of CO₂ emissions. In 2020, it is expected that international aviation will consume between 216 and 239 Mt of fuel, resulting in 682 to 755 Mt of CO₂

emissions. By 2040, fuel consumption is projected to have increased 2.8 to 3.9 times the 2010 value, while revenue tonne kilometres are expected to increase 4.2 times under the central demand forecast. By extrapolating to 2050, fuel consumption is projected to have increased 4 to 6 times the 2010 value, while revenue tonne kilometres are expected to increase 7 times under the central demand forecast.

3.6.2 Under Scenario 9, aviation fuel efficiency is expected to improve at an average rate of 1.4 per cent per annum to 2040, and at 1.39 per cent per annum, if extrapolated to 2050. While in the near term (2010 to 2020), efficiency improvements from technology and improved ATM and infrastructure use are expected to be moderate, they are projected to accelerate in the mid-term (2020 to 2030). During the 2020 to 2030 period, fuel efficiency is expected to improve at an average rate of 1.76 per cent per annum under Scenario 9. This analysis shows that additional technological and operational improvements beyond even those described in Scenario 9 will be required to achieve the global aspirational goal of 2 per cent per annum fuel efficiency.

3.7 Trends in Full-Flight NOx Emissions

The following scenarios were assessed for Full Flight NOx.

3.7.1.1 **Scenario 2** is the moderate aircraft technology and CAEP/9 Independent Expert (IE) Operational Improvement case that assumes aircraft NOx improvement based upon achieving 50 percent of the reduction from current NOx Emission levels to the NOx Emissions levels by CAEP/7 NOx IE goals review (-60 percent +/- 5 percent of current CAEP/6 NOx Standard) for 2026, with no further improvement thereafter. CAEP/9 IE Operational Improvement factors are provided in Table 2.

3.7.1.2 **Scenario 3** is the advanced aircraft technology and CAEP/9 IE Operational Improvement case that assumes aircraft NOx improvement based upon achieving 100 percent of the reduction from current NOx Emission levels to the NOx Emissions levels by CAEP/7 NOx IE goals review (-60 percent +/- 5 percent of current CAEP/6 NOx Standard) for 2026, with no further improvement thereafter.

3.7.1.3 Two models contributed results to the Full Flight NOx trends assessment: (1) FAA's Aviation Environmental Design Tool (AEDT); and (2) EUROCONTROL's IMPACT. MDG results for global (domestic plus international) operations are shown in Figure 20. The 2010 baseline NOx value is 3.17 MT. In 2040, the NOx value ranges from about 6.76 MT with Scenario 3 to 8.93 MT with Scenario 2. MDG results for international operations are shown in Figure 21. The 2010 baseline NOx value is 2.15 MT. In 2040, the NOx value ranges from about 4.81 MT with Scenario 3 to 6.35 MT with Scenario 2.

Agenda Item 2: Review of models and databases**2.1 COORDINATION BETWEEN WORKING GROUPS**

2.1.1 Due to the substantial resource demands and complexity of the CAEP/10 Work Programme, and the numerous cross-cutting issues between the various CAEP working groups, the groups took deliberate action to ensure sufficient coordination. This included frequent reviews of activities that required coordination and jointly reporting on those activities to each of the Steering Group meetings.

Discussion and Conclusions

2.1.2 The meeting thanked the Co-Rapporteurs for their effective, necessary coordination throughout the CAEP work programme.

2.2 MDG PROGRESS REPORT

2.2.1 The co-Rapporteurs of MDG presented an overview of MDG activities during CAEP/10. The work that related to policy option analyses of the environmental benefits and interdependencies of a potential ICAO Aeroplane CO₂ Emission Standard is described under Agenda Item 5 in paragraphs 5.1.1 – 5.1.3. Related work, which summarizes the models and databases used to support the CO₂ analyses, is described under Agenda Item 5 in paragraphs 5.1.5 – 5.1.8. In addition, MDG provided updated fuel, noise, local air quality (LAQ) and the full-flight NO_x trends assessments to the 2010 baseline, and further details are provided under Agenda Item 1 in paragraphs 1.1.1 – 1.1.17.

2.2.2 MDG has provided support to the ICAO Secretariat regarding the dissemination of MDG modelled results. This was done on an ad hoc basis, for example, preparing the fuel trends results for the 38th Session of the ICAO Assembly and providing input to the 2013 ICAO Environmental Report. MDG has also provided support to the Global Market-based Measures Technical Task Force (GMTF), and more details can be found under Agenda Items 9 and 10.

2.2.3 With regard to a possible non-volatile Particulate Matter (nvPM) Standard, MDG has continued to coordinate with WG3, and on an ad-hoc basis has provided clarity on the modelling process, and on nvPM emissions that were previously estimated through the First Order Approximation (FOA) method. This is in preparation for MDG to conduct sample problem and policy option analyses of the environmental benefits and interdependencies of a potential nvPM standard during CAEP/11.

2.2.4 MDG has continued to work with WG2 to conduct an analysis of the benefits of the Aviation System Block Upgrades (ASBU). The results of this task are presented under Agenda Item 7 in paragraphs 7.6.1 – 7.6.6.

2.2.5 For the CAEP/10 CO₂ Standard stringency analysis, CAEP used the Common Operations Database (COD). In anticipation of the CAEP/11 work programme, the geographic scope of the COD is in the process of being broadened. To date, annual radar data, besides North America and Europe, has been provided to MDG by Brazil and Argentina, and the availability of data is currently being discussed with Australia. MDG is working to integrate these data into an updated version of the COD. The ICAO Secretariat has also disseminated a broad call for data, which includes a request for additional radar data.

2.2.6 The co-Rapporteurs of MDG highlighted that the First Meeting of the Aviation Data and Analysis Panel (ADAP/1) was held in Montréal from 14 to 17 April 2014. It was highlighted that CAEP coordination and participation in the ADAP was ongoing, with MDG providing support as needed.

2.3 DATABASES AND MODELS

2.3.1 The co-Rapporteurs of MDG presented the continuing work on model evaluation, which has included sensitivity tests, comparisons with “gold standard data”, and sample problems. MDG has refined the process as appropriate on the basis of relevant criteria, to better inform CAEP which tools are sufficiently robust, rigorous and transparent, and appropriate for which analysis, and why there might be differences in modelling results. A summary of the models and databases used to support the CAEP/10 work programme was presented. MDG has completed the evaluation of the Russian Federation’s AcousticLab noise model and deemed it acceptable for CAEP analyses. The meeting was informed that MDG is currently evaluating two candidate environmental models: (1) the Ukraine’s PolEmiCa local air quality model; and (2) the Ukraine’s IsoBella noise model. A complete list of the models and databases that have been reviewed for use within CAEP is presented in Appendix A.

2.3.2 A member presented her views on the evolution of civil aviation commercial fleets. It was proposed that following the introduction of new ICAO environmental Standards, that it is logical to update the assessment of the potential fleet response to any new standard. As CAEP introduces new standards, it is important to understand if these standards are driving the desired behaviour, both through projection prior to the introduction of the standard and through looking at actual insertion after the applicability date of the standard. The member proposed a comprehensive fleet evolution analysis to understand the effects of standards by projecting the fleet composition and associated noise certification levels of passenger and cargo jet airplanes operating globally from 2010 to 2040.

2.3.3 Several members and observers presented an update on the activities related to European models and databases during the CAEP/10 cycle and provided some insight into future developments of relevance for the CAEP/11 work programme. This included details on global operations databases, fleet and operations forecasting, noise, and emissions. The several members and observers supported further work by MDG on the COD and model evaluation during CAEP/11, and suggested that MDG and WG3 be jointly tasked to develop a modelling methodology for full-flight nvPM emissions.

2.3.4 Some members presented their views on model and database tasks for the CAEP/11 work programme, and they supported the continued improvement of the models and databases used by CAEP. They recommended enhancing legacy models (for LAQ, economics, GHG and noise modelling) and highlighted database considerations (on airport and fleet databases, and the COD, among others). Some members also suggested new modelling capabilities and that CAEP should continue to examine and integrate the latest science and research within its modelling. They encouraged States to identify tools capable of carrying out cost benefit analysis (CBA), and submit them for evaluation and potential use for future CAEP assessments.

2.3.5 An observer presented his views on prioritizing several potential future work items by WG3 and MDG/FESG during the CAEP/11 work cycle. These included work to develop an engine nvPM emission standard, a revised Independent Expert (IE) fuel burn technology review, and an assessment of the contribution of the agreed CAEP/10 CO₂ Standard to ICAO’s high level climate protection goals, namely the 2% fleet wide annual fuel efficiency target.

Discussions and Conclusions

2.3.6 The meeting agreed that the evaluation of the Russian Federation's AcousticLab has been successfully completed and congratulated the Russian Federation on the development of this model. The future contribution of AcousticLab to the work of CAEP was welcomed. The meeting thanked MDG for its work and agreed that sufficient documentation had been provided for the databases and models used in CAEP/10 analyses.

2.3.7 Appreciation was expressed to MDG and FESG for their commitment to supporting a CAEP data-driven decision-making process. The meeting recalled that while all documentation of analyses presented to meetings is made available to members to support discussions, the models and databases used to conduct those analyses may have restrictions, such as for proprietary and sensitive information, that limit their access and distribution. The databases presented in Table 2 of Appendix A contain such information and were used in support of CAEP/10 analyses, but are not available for public use. Noting the proposed task for a "lessons learned" report from the CAEP/10 analyses, the meeting recommended that the scope of that task include a review of the proposed enhancements to the COD.

2.3.8 Significant interest in the proposed work related to the evolution of the global aircraft fleet was expressed by the meeting. Results to be presented at the regional level and, if possible, for business aircraft could help to inform decision makers within a broad range of stakeholders.

2.3.9 The meeting discussed the submission of tools to support CBA with a view to seeing if they could inform CAEP decisions. Caution regarding the risk of misuse or misinterpretation of certain categories of cost metrics, in particular societal costs was noted. The meeting agreed that a clearer scope of how CBA would be applied in CAEP and its possible implications would be necessary prior to taking a decision on its use. The specifics of how CBA might support decision-making in CAEP will be discussed as part of the agenda item on future work.

2.4 PROPOSED AMENDMENTS TO ICAO DOC 9911

2.4.1 The MDG co-Rapporteurs presented proposed amendments to ICAO Doc 9911, *Recommended Method for Computing Noise Contours Around Airports*. The proposed amendments included editorial updates and clarifications identified during software development efforts, that were identified during the process of updating Doc 9911, as well as implementing the Doc 9911 methodology in software. Further updates were also identified through a parallel effort conducted by ECAC AIRMOD to update the third Edition of Doc 29, Volumes 1 and 2. These updates help to remove some ambiguity found in the original text in ICAO Doc 9911.

Discussions and Conclusions

2.4.2 In approving the proposed updates to ICAO Doc 9911, *Recommended Method for Computing Noise Contours Around Airports*, the meeting recognised the excellent work conducted by MDG in updating the document.

2.4.3 The meeting agreed that ICAO should publish an amended version of ICAO Doc 9911, *Recommended Method for Computing Noise Contours Around Airports* as prepared by MDG, following the standard procedure for publications, which includes an editorial review.

2.4.4 Recommendation

2.4.4.1 In light of the discussions the following recommendation was developed:

**Recommendation 2/1 — Update to ICAO Doc 9911,
*Recommended Method for Computing Noise Contours Around
Airports***

ICAO is requested to publish the update to ICAO Doc 9911,
*Recommended Method for Computing Noise Contours Around
Airports*.

2.5 MDG EVALUATION OF THE ICAO CO₂ REPORTING AND ANALYSIS SYSTEM (ICORAS)

2.5.1 The MDG co-Rapporteurs presented an evaluation of the ICAO CO₂ Reporting and Analysis System (ICORAS), which included an assessment of the design and the method by which the system estimates missing fuel burn data. The review found that the methodology used to assign priority to available data appears to be based on a logical progression based on the comprehensiveness of each data source. The MDG co-Rapporteurs provided suggestions for clarification of the documentation and for future improvements. As part of the review, MDG evaluated the ICAO fuel formula and found that it is suitable for estimating missing fuel burn as described in the ICORAS methodology, as well as for use within the ICAO Carbon Emissions Calculator.

Discussions and Conclusions

2.5.2 The meeting agreed that the review of ICORAS by CAEP is now complete. ICORAS was found to be fit for purpose, but not a CAEP-approved model. The Secretariat confirmed that the improvements recommended by MDG are scheduled to be implemented during the next ICORAS development phase.

2.6 REPORT OF THE FESG

2.6.1 The Co-Rapporteurs of the Forecast and Economic Analysis Support Group (FESG) presented the group's report. The group established two task groups: the Forecast Task Group (FTG) and the Stringency Task Group (STG) to undertake the tasks that were assigned. It was explained that Task F.04, cost-effectiveness analysis of potential PM policy options, was removed since no work relating to the economic assessment of the potential Non Volatile Particulate Matter (nvPM) policy options would be initiated during this CAEP cycle.

2.6.2 Review of Economic Models (Task F.01)

2.6.2.1 The FESG finalised the documentation on its review of economic models and on the databases that were used to support the economic assessment of the CO₂ policy options under consideration at CAEP/10 as well as the review process conducted.

2.6.3 Review of FESG CAEP/9 Forecast (Task F.02)

2.6.3.1 At the CAEP/9 meeting, the FESG was tasked to conduct a review of the CAEP/9 forecast to address potential issues and facilitate its implementation to support the CAEP/10 analyses. During the cycle, the FESG FTG has worked in close coordination with modellers to address issues relating to the implementation of the CAEP/9 forecast for the CO₂ sample problem and main analysis work.

2.6.4 Cost-effectiveness analysis of potential CO₂ policy options (Task F.03)

2.6.4.1 This economic assessment of the CO₂ policy options under consideration for CAEP/10 was performed by the FESG STG, which has worked in close coordination with the MDG during the cycle. The results of this assessment are discussed further under Agenda Item 5.

2.6.5 ADAP Participation (Task F.05)

2.6.5.1 The FESG FTG participated actively in the work of the ICAO Aviation Data and Analysis Panel (ADAP) Multi-Disciplinary Working Group on Long-Term Traffic Forecasts (MDWG-LTF) with a view of ensuring that CAEP forecasting needs and requirements are taken into due consideration in the development of the harmonized set of long-term traffic forecasts.

2.6.5.2 Although the ADAP MDWG-LTF has been mandated to develop the single set of harmonized (passenger and cargo) traffic forecasts that all entities within ICAO requiring a traffic forecast (including CAEP) would have to use, the responsibility for developing the passenger and freighter fleet forecasts as well as the traffic and fleet forecasts for aircraft with less than 20 seats (business jets) remains within CAEP. The FESG FTG has therefore initiated some discussions on the planning for the development of the new FESG forecasts to be used in support to the CAEP/11 analyses and pursued its discussions and preparatory work up until the end of the CAEP/10 cycle.

Discussion and Conclusions

2.6.6 The meeting thanked the FESG for their work, in particular for the significant efforts in support of the CO₂ Standard-related analyses and their support to ADAP. It noted that many of the future work items being discussed for the CAEP/11 cycle will require tailoring of ICAO Long Term Forecast (LTF). Therefore, there is a dependency on the availability of the ICAO LTF as well as on the specialized resources to tailor it being made available. The schedule for ADAP producing the ICAO LTF will be confirmed under Agenda Item 1.

2.7 ACCS WORK PROGRAMME OVERVIEW

2.7.1 The Aviation Carbon Calculator Support Group (ACCS) co-Rapporteurs presented an overview of ACCS activities during CAEP/10. ACCS developed a methodology to estimate the amount of emissions, on an airport-pair basis, that would have been offset by operators as the result of exceeding their emissions allowances within an offsetting scheme. To assist this effort the ICAO Secretariat received reported and verified CO₂ emissions from aviation activities covered by the EU Emissions Trading System (ETS) for the years 2013 and 2014. The ICAO Secretariat also provided a specialized interface to the ICAO Carbon Emissions Calculator, in support of the Climate Neutral UN initiative. The Issue Management Group of the UN Environment Management Group (UNEMG-IMG) is currently

reviewing the information provided by ICAO for possible use in developing their 2015 emissions inventories.

2.7.2 ACCS considered possible updates to the ICAO Carbon Emissions Calculator passenger methodology, and in connection with this, ACCS reviewed a report from the World Bank entitled *Calculating the Carbon Footprint from Different Classes of Air Travel* (Policy Research Working Paper 6471, May 2013). The ACCS analysis of the approach in the report showed that the methodology offers increased differentiation by class of service. From a global perspective, implementing this methodology would result in the share of emissions from a given flight being slightly less for economy class passengers, slightly more for business class passengers and significantly more for first class passengers (for which there was previously no distinction). This methodology requires load factor data by class of service, for which no complete source has been identified. Therefore, ACCS did not recommend changing the passenger methodology, until a source of load factor data by cabin class can be found.

2.7.3 As directed by 2015 CAEP Steering Group meeting, ACCS pursued the provision of information on the collection of offset data in support of the GMTF Emissions Unit Criteria (EUC). This task did not require more work beyond an initial discussion with the GMTF EUC co-leads.

Discussions and Conclusions

2.7.4 The meeting recommended that the ICAO Fuel Formula be used by the ICAO Carbon Emissions Calculator.

2.8 AVIATION CARGO CALCULATOR METHODOLOGY

2.8.1 The ACCS co-Rapporteurs presented details on the development of a methodology to estimate the emissions associated with the shipment of cargo by air. The methodology is comprised of two elements: 1) a methodology that can be implemented by the ICAO Secretariat to estimate emissions associated with a future shipment (similar to the passenger ICAO Carbon Emissions Calculator), and 2) a methodology that can be implemented by operators to compute the CO₂ emissions for shipments that have already occurred.

2.8.2 The methodology is presented in three tiers so that precise data on the aircraft type and routing can be used when it is known, and estimated otherwise. The Tiers are as follows:

- Tier 1 – Predictive Methodology (Dedicated Cargo Aircraft) – is aimed at the typical consumer who wishes to ship a package by air. They will likely not have access to any information beyond the origin and destination of their shipment and the weight of the item.
- Tier 2 – Predictive Methodology (Belly Cargo) – assumes that a package is being shipped on board a passenger aircraft and that the user knows the origin and destination airport for the item as well as any intermediate airports that the item may transit. This methodology starts with the passenger methodology, which already includes a passenger to cargo ratio for passenger aircraft.
- Tier 3 – Post-flight Methodology (Dedicated Cargo Aircraft and Belly Cargo) – was originally developed by IATA as Recommended Practice 1678 and is intended to be implemented by an operator with perfect knowledge of

the routing flown, load factor, and the aircraft types used for a given shipment. This method provides the highest accuracy of result, but also requires the most data and cannot be used to estimate the emissions in advance of a shipment.

Discussions and Conclusions

2.8.3 Some observers expressed concern on the uncertainty of the predictive methodologies. The meeting suggested that the term “part” would be more appropriate than “tier” for describing the cargo carbon emissions methodology. With that amendment, the meeting agreed that the three-part methodology should become the ICAO Cargo Carbon Emissions Calculator Methodology, and the meeting agreed that the ICAO Secretariat should implement the predictive elements of the methodology (Parts 1 and 2) for use by the public, the UN system, and other users. The meeting recognized that the post-flight methodology (Part 3) depends on detailed information that is only available to air cargo operators once an item has been shipped. In updating the ICAO Carbon Emissions Calculator to implement Parts 1 and 2 of the methodology, a clear statement of the limitations of the predictive methodology should be displayed to the user. A number of members and observers offered to work with the Secretariat to develop appropriate text in this regard. The meeting recommended that air cargo operators should implement Part 3 of the methodology for use by their customers.

2.8.4 The meeting agreed that ACCS has satisfactorily completed the tasks assigned to it.

2.8.5 Recommendation

2.8.5.1 In light of the discussions the following recommendation was developed:

Recommendation 2/2 — ICAO Cargo Carbon Emissions Calculator Methodology

That the ICAO Carbon Emissions Calculator be updated to reflect the CAEP-approved cargo methodology, including the caveats.

APPENDIX A
(English only)

LIST OF MODELS AND DATABASES REVIEWED FOR USE WITHIN CAEP

The following databases and models have been reviewed by CAEP and were found suitable for use in support of the CAEP/10 work programme.

The CAEP/10 cycle included two analyses: CO₂ Standard and environmental trends. Databases used during CAEP/10 for these analyses are summarized in the following tables. **Table 1** lists databases that are external to CAEP and common to the above two analyses. **Table 2** lists databases that were used in both CAEP/10 analyses; but, which are not for public use. **Table 3** lists databases that were uniquely developed for the CO₂ main analysis (CO₂ma).

Table 1. Databases External to CAEP

ANP - Aircraft Noise and Performance Database Version 3.0	EUROCONTROL
Base of Aircraft Data (BADA) versions 4.1 and 3.12	EUROCONTROL
ICAO Aircraft Engine Emissions Databank version 20b, 2014-03	WG3, EASA
ICAO Noise Certification Database (NoisedB) version 2.18, 2015-04	WG1, French DGCA
Population Database, Version 3.0, 2015-08	MDG, US FAA/Volpe, EEA

Table 2. CAEP Databases used in CAEP/10 Analyses

2010 CAEP 9 Campbell-Hill Fleet Database, 2012-12	A4A, MDG
2010 CAEP 9 Campbell-Hill Fleet Database Extension, 2012-12	MDG, US FAA/Volpe
Airports Database, version 2.9.0, 2014-08	MDG, US FAA/Volpe, EUROCONTROL
Environmental Trends 2010 Common Operations Database (COD), version 1.0, 2013-02	MDG, US FAA/Volpe, EUROCONTROL
FESG CAEP/9 Retirement Curves, 2012	FESG
FESG CAEP/9 Traffic and Fleet Forecast, 2012-12	FESG
CAEP/10 Trends Growth and Replacement (G&R) database, Version 1.9	MDG, WG3, WG1

Table 3. CAEP Databases developed for the CO₂ main analysis (CO₂ma)

CO ₂ ma Fleet Evolution Input Database (FEID), 2014	MDG, FESG
CO ₂ ma Fleet Evolution Output Database (FEOD), 2015	MDG
CO ₂ ma Growth and Replacement (G&R) database, Version 4-1a, 2015-01-11	MDG, FESG, WG3, WG1
CO ₂ ma CAEP Metric Value database (MVdb), Version 8.1, 2014-02	WG3
CO ₂ ma Project Aircraft Metric Value database (PAMVdb), Version 15, 2014	WG3
CO ₂ ma 2010 Common Operations Database (COD), 2012	MDG
CO ₂ ma Stringency Options database (SOdb), Version 9, 2014-04	WG3

Models used in the CAEP/10 CO₂ and trends analyses are listed in Table 4. The models, and any model evaluation process, cover the following analysis areas: cost effectiveness, fleet evolution, fuel burn and greenhouse gas emissions (GHG), local air quality (LAQ) and noise.

Table 4. CAEP/10 Analysis Models

	Model	Release	Release Date	Area	Sponsor
AEDT	Aviation Environmental Design Tool	2B	2015	Noise, LAQ, and GHG	US FAA
ANCON2	Aircraft Noise Contour Model	2.3	October 2010	Noise	UK DfT
STAPES	SysTEM for AirPort noise Exposure Studies	1.2	October 2009	Noise	EUROCONTROL, EC and EASA
AcousticLab ¹	Aircraft noise assessment model	1.7	April 2015	Noise	Civil Aviation Environmental Safety Center (CAESC), Russian Federation
ADMS-Airport/EMIT	Atmospheric Dispersion Modelling System	3.4	October 2014	LAQ	UK DfT
ALAQs-AV	Open-Airport Local Air Quality Studies	2.0	December 2009	LAQ	EUROCONTROL
LASPORT	LASAT for Airports	2.2	March 2015	LAQ	Swiss Federation Office for Civil Aviation (FOCA) German Ministry of Transport (BMVI)
PEGASUS	Pollution Estimation from General Aviation Sources	2.0	June 2015	LAQ	CAESC (PEGAS) TsAGI (PEGASUS)
AEM Kernel	Advanced Emission Model	V2.5.2	April 2014	GHG	EUROCONTROL
IMPACT ²	IMPACT Modelling System	3.10	May 2014	GHG, Noise and LAQ	EUROCONTROL
FAST	Future Civil Aviation Scenario Software Tool	FAST_v2_I D141013	13 October 2014	GHG	UK DfT
APMT-Economics	Aviation environmental Portfolio Management Tool for Economics	5.6.8	2014	Fleet Evolution & Cost-Effectiveness (Economics)	US FAA
AAT	Aircraft Assignment Tool	V2.0 live	December 2014	Fleet Evolution (Economics)	EUROCONTROL, EC and EASA
CO ₂ CSM	CO ₂ Cost Spreadsheet Model	CAEP/10	2015	Cost-Effectiveness (Economics)	ICAO, FESG

¹ The AcousticLab noise model was successfully evaluated during CAEP/10, but was not available in time to support the CO₂ or environmental trends analyses.

² IMPACT is a multi-airport environmental impact assessments tool for noise, gaseous and particulate emissions, and local air quality modelling; noise calculations are performed by the noise computation module of the SysTEM for AirPort noise Exposure Studies (STAPES) model and GHG emission calculations are carried out by the Advanced Emission Model (AEM). Although IMPACT includes both noise and GHG modelling capabilities, the tool has been used to support only the GHG portion of CAEP/10 assessments. The noise assessments have been performed using the original standalone version of STAPES (as in the previous CAEP cycles).

Agenda Item 3: Review of technical proposals relating to aircraft engine emissions**3.1 REPORT OF WG3**

3.1.1 The co-Rapporteurs of WG3 provided an overview of the work carried out by WG3 during the CAEP/10 work programme. The majority of the work items have been dealt with by three Task Groups (CO₂ (CO2TG); Particulate Matter (PMTG); and Certification (CTG)). The work on the non-volatile Particulate Matter (nvPM) Standard and the CO₂ Standard (and the associated specific amendments to Annex 16) were provided in separate self-contained reports and are dealt with under Agenda Items 4 and 5 respectively. The general proposed amendments to Annex 16, Vol. II, outside of the work of nvPM and CO₂ Standards, are dealt with under paragraph 3.2 of this Agenda Item.

3.1.2 WG3 was tasked with monitoring trends in the aviation kerosene fuel supply composition and the assessment of consequences for emissions. In September 2014, ICAO issued a State letter (AN 1/17–14/57) to request data in order to better understand the composition of commercial fuel and the availability of fuel meeting the Annex 16, Vol. II certification specifications. Several replies were received from States and international organizations and these were reviewed by WG3, and while not resulting in any technical recommendations, WG3 concluded that such fuel specification data collection were useful and should be repeated in the future.

3.1.3 Regarding the WG3 tasks on reviewing the NO_x Cruise-Climb Relationship for staged combustion and future engine technologies, and the monitoring of certification requirements for both supersonic transport and for new engine concepts, progress has been limited. WG3 proposed that work in these areas be continued at a low to medium level of priority during CAEP/11.

3.1.4 WG3 was tasked with providing an assessment of Aircraft Fuel Efficiency Technology Advances for subsonic aircraft. Progress on this task has been limited due to resource constraints and the ongoing work on the CO₂ Standard development. On Combustion Technology Advances, as was reported to SG2015, an industry-led combustion technology review was held in Garching by Munich, Germany from 1 - 2 October 2014. The full report of the industry-led combustion technology review was provided to the meeting.

3.1.5 Throughout the CAEP/10 cycle, WG3 has continued to liaise with MDG regarding the development of the Growth and Replacement (G&R) database for the CO₂ main analysis (CO2ma). This work formed the basis of WG3 communication to MDG of the technical assumptions related to the CO2ma.

3.1.6 The ICAO Engine Emissions Databank (ICAO EEDB), was last updated on 10 February 2015 and the latest version 21B, was published by EASA on behalf of ICAO. The latest version contains new and revised engine emissions data, format changes and additions that have no consequence on the calculation of characteristic emissions values.

Discussion and Conclusions

3.1.7 The meeting thanked WG3 for its dedication, efforts and high quality work during this CAEP cycle. Regarding the industry-led combustion technology review, the meeting accepted the report presented by WG3 on the latest assessment of advances in engine combustor design technologies for subsonic aircraft.

3.2 PROPOSED GENERAL AMENDMENTS TO ANNEX 16, VOLUME II

3.2.1 The Co-Rapporteurs of WG3 presented a report on the general proposed amendments to Annex 16, *Environmental Protection, Volume II – Aircraft Engine Emissions*. These changes included all proposed general amendments that are outside of the technical amendments associated with the nvPM and CO₂ Standards.

3.2.2 Work item 1: Part I – Definitions

3.2.2.1 It was proposed to add a definition of “engine type certification” in Annex 16, Volume II, Part I, Chapter 1.

3.2.3 Work item 2: Part III, Chapter 1

3.2.3.1 It was proposed to add a definition of “engine derivative versions” into Annex 16, Volume II, Part III, Chapter 1, Paragraph 1.1. This change was in addition to changes due to the proposed new Chapter 4 on nvPM (see Agenda Item 4) and due to a typographical error.

3.2.4 Work item 3: Part III, Chapter 2

3.2.4.1 For consistency purposes with the new proposed Chapter 4 on nvPM, it was proposed to change the title of the four Landing Take-Off (LTO) modes in Annex 16, Volume II, Part III, Chapter 2, paragraph 2.1.4.3, from “phase” to “LTO operating mode”.

3.2.5 Work item 4: Appendix 3 – Sampling Line Temperature Stability

3.2.5.1 For clarification purposes, it was proposed to delete the phrase “with a stability of $\pm 10^{\circ}\text{C}$ ” from the requirement to maintain the line temperature at $160 \pm 15^{\circ}\text{C}$ (with a stability of $\pm 10^{\circ}\text{C}$) in Annex 16, Volume II, Appendix 3, paragraph 5.1.2.

3.2.6 Work item 4: Appendix 3 – Carbon Balance Check

3.2.6.1 For editorial purposes, it was proposed to delete “within” and to add “with an accuracy of” in Annex 16, Volume II, Appendix 3, paragraph 6.4.

3.2.7 **Work item 5: Attachment D to Appendix 3 - Calibration Gas for NO_x**

3.2.7.1 For the NO_x analyser, Annex 16, Volume II requires a test gas of NO in zero nitrogen¹ and a calibration gas of NO_x in zero nitrogen. SAE Aviation Recommended Practice (ARP) 1256D recommends NO_x for both. Following investigations by WG3 and the SAE E-31 Committee both have recommended to specify the use of nitrogen monoxide (NO) in zero nitrogen for both the test gas and the calibration gas. It was proposed to change the calibration gas to NO in Annex 16, Volume II, Appendix 3, Attachment D.

3.2.8 **Work item 6: Appendix 4 – Naphthalene Content**

3.2.8.1 It was highlighted that there is an increasing difficulty to find fuels with a naphthalene content of at least 1% in volume as specified in Annex 16, Volume II, Appendix 4. To address this it was proposed to change the emissions test fuel specification from having a naphthalene content from “1-3.5%” to “0.0 to 3.0%”.

3.2.9 **Work item 7: Appendix 6**

3.2.9.1 Changes were proposed to Annex 16, Volume II, Appendix 6 that include an update to the general requirements, a new compliance procedure for nvPM emissions, coefficients for the nvPM mass characteristic level and a change to the title of Table A6-1. A correction was also proposed to the formulae in Table A6-1.

3.2.10 **Work item 8: Typographical**

3.2.10.1 It was proposed to replace “NO_x” by “NO_x” (“x” subscript by “x” lower case) throughout Annex 16, Volume II. Additionally, some general typographical errors were proposed.

3.2.11 **Work item 9: Reference to ISO in the Foreword**

3.2.11.1 The certification procedures for the proposed nvPM Standard make extensive use of the specifications developed by ISO. Therefore, it was proposed to add a paragraph in the Foreword to Annex 16, Volume II, indicating this reference.

3.2.12 **Work item 10: Consistency for nvPM Chapters**

3.2.12.1 It was proposed to correct a number of inconsistencies in the Chapters associated with nvPM. The corrections include changes to definitions and alignment of symbols related to nvPM used throughout Annex 16, Volume II.

3.2.12.2 It was also proposed to add “for engine performance” to Annex 16, Volume II, Chapter 2 paragraphs 2.1.4.1 and Chapter 3, 3.1.5.1 to read: “The reference atmospheric conditions for engine performance shall be ISA at sea level except that the reference absolute humidity shall be 0.00634 kg water/kg dry air.”

¹ Zero nitrogen shall be used as the zero gas. The zero gas is the gas used in establishing the zero, or no response, adjustment of an instrument.

Discussion and Conclusions

3.2.13 The meeting noted the importance of the work to maintain Annex 16, Volume II in order to keep it up to date, relevant with regard to current certification practices. The meeting approved the general amendments to Annex 16, Volume II as presented in Appendix A.

3.2.14 Recommendation

3.2.14.1 In light of the foregoing discussion, the meeting developed the following recommendation:

RSPP | **Recommendation 3/1 — General Amendments to Annex 16**
| **— *Environmental Protection, Volume II — Aircraft Engine***
| ***Emissions***

| That Annex 16, Volume II be amended as indicated in
| Appendix A to the report on this agenda item.

3.3 GENERAL PROPOSED AMENDMENTS TO THE ENVIRONMENTAL TECHNICAL MANUAL, VOLUME II

3.3.1 The Co-Rapporteurs of WG3 presented proposed amendments to ICAO Doc 9501, Environmental Technical Manual, Volume II – Procedures for Emissions Certification of Aircraft Engines.

3.3.2 Work item 1: Foreword

3.3.2.1 It was proposed to add a Foreword to the ETM, Volume II that is consistent with Volumes I and the proposed Volume III. This Foreword will allow for amendments to the ETM, Volume II be approved by CAEP Steering Group Meetings and be made available, free of charge on the ICAO website, pending a final decision on official publication by the ICAO Secretary General.

3.3.3 Work item 2: Definition of Engine Type Certificate

3.3.3.1 It was proposed to add additional information on the type certificate definition to the ETM, Volume II in order to provide further guidance.

3.3.4 Work item 3: Calibration and Test Gas for the NO_x Analyser

3.3.4.1 It was proposed to provide new “technical procedure” information on the NO_x analyser calibration that supports the proposed change in the calibration gas to NO in Annex 16, Volume II, Appendix 3, Attachment D (see paragraph 3.2.7 of this report).

3.3.5 **Work item 4: Elect to Comply to a Later Standard**

3.3.5.1 It was proposed to provide the engine manufacturers the option to comply with a later Standard, even though at the time of the date of manufacture of the first production model the more stringent Standard is not applicable.

3.3.6 **Work item 5: Latest Emission Standard Applied**

3.3.6.1 To clarify paragraph 4, “Latest emissions Standard applied” for the “technical procedure” under the ETM, Volume II, Chapter 2, paragraph 2.1.1, it is proposed to add the word “applicable” in the first sentence.

3.3.7 **Work item 6: Temperature of the Probe for Gas Measurements**

3.3.7.1 Annex 16, Volume II, Appendix 3 neither requires a minimum temperature nor mentions active cooling of the probe for gas or smoke measurements. It was proposed to add an “EXPLANATORY INFORMATION” to the ETM, Volume II, Appendix 3, paragraph 5.1.1 “Sampling probe.”

3.3.8 **Work item 7: Carbon Balance Check**

3.3.8.1 As some engine manufacturers are using SAE ARP1256 and ARP1533 to perform the carbon balance check, there was a need to explain and assess the differences between Annex 16, Volume II which uses the Air Fuel Ratio (AFR), and the ARP1256 which uses Fuel Air Ratio (FAR). In addition, ARP1533 explains how to calculate a carbon balance and a FAR balance. To clarify, it was proposed to add additional guidance text into the ETM, Vol. II.

3.3.9 **Work item 8: Vented Fuel**

3.3.9.1 It was proposed to provide technical and equivalent procedures to meet the fuel venting requirements of Annex 16, Volume II, Part II.

3.3.10 **Work item 9: No Emissions Change**

3.3.10.1 It was proposed to provide additional guidance text to capture the current process involved in the “no emissions change” certification process. The text proposed included a modification to the first bullet to include a reference to Annex 16, Volume II, Appendix 3 instead of using the current equations, to ensure consistency.

3.3.11 **Work item 10: Table of Contents Updates**

3.3.11.1 It was proposed to update the table of contents in order to accommodate the proposed changes to the ETM, Volume II and additions associated with the proposed nvPM Standard.

Discussion and Conclusions

3.3.12 In approving the proposed amendments to the ETM, Volume II, as presented in the report from the working group, the meeting recognised the work conducted by WG3 in the maintenance of the manual. The meeting agreed that revised versions of the ETM, Volume II, approved by subsequent CAEP Steering Groups be made available, free of charge on the ICAO website, pending a final decision on official publication by the ICAO Secretary General.

3.3.13 Recommendation

3.3.13.1 In light of the foregoing discussion, the meeting developed the following recommendation:

**Recommendation 3/2 — General Amendments to the
Environmental Technical Manual, Volume II – *Procedures
for the Emissions Certification of Aircraft Engines***

That the *Environmental Technical Manual*, Volume II be amended and published, and revised versions approved by subsequent CAEP Steering Group Meetings be made available, free of charge on the ICAO website, pending a final decision on official publication by the ICAO Secretary General.

3.4 EMISSIONS TECHNICAL FUTURE WORK

3.4.1 A member presented views on the importance of WG3 emissions tasks and that the maintenance of Annex 16 and the ETM are fundamental work items of WG3. The member commented on the new Standards for nvPM and CO₂ and that as they are put into practice additional changes to the Annex and ETM would likely be required. The member also considered a number of other ongoing tasks to be of high priority, including the first stringency of the nvPM emissions standard for engines >26.7 kN thrust, and potentially replace the smoke standard, supporting a CAEP/11 Independent Experts Technology Review, and updating the ICAO Doc 9889, *Airport Air Quality Manual*.

APPENDIX A**PROPOSED AMENDMENTS TO ANNEX 16, VOLUME II**

The text of the amendment is arranged to show deleted text with a line through it and new text highlighted with grey shading, as shown below:

1. ~~Text to be deleted is shown with a line through it.~~ text to be deleted
2. **New text to be inserted is highlighted with grey shading** new text to be inserted
3. ~~Text to be deleted is shown with a line through it~~ followed by the replacement text which is highlighted with grey shading. new text to replace existing text

**TEXT OF PROPOSED AMENDMENTS TO THE
INTERNATIONAL STANDARDS
AND RECOMMENDED PRACTICES
ENVIRONMENTAL PROTECTION
ANNEX 16
TO THE CONVENTION ON INTERNATIONAL CIVIL AVIATION
VOLUME II
AIRCRAFT ENGINE EMISSIONS**

FOREWORD

Editorial practices

The following practice has been adhered to in order to indicate at a glance the status of each statement: *Standards* have been printed in light face roman; *Recommended Practices* have been printed in light face italics, the status being indicated by the prefix ~~Recommendation~~ **Recommendation**; *Notes* have been printed in light face italics, the status being indicated by the prefix *Note*.

It is to be noted that in the English text the following practice has been adhered to when writing the specifications: Standards employ the operative verb “shall” while Recommended Practices employ the operative verb “should”.

The units of measurement used in this document are in accordance with the International System of Units (SI) as specified in Annex 5 to the Convention on International Civil Aviation. Where Annex 5 permits the use of non-SI alternative units, these are shown in parentheses following the basic units. Where two sets of units are quoted it must not be assumed that the pairs of values are equal and interchangeable. It may, however, be inferred that an equivalent level of safety is achieved when either set of units is used exclusively.

Any reference to a portion of this document which is identified by a number includes all subdivisions of that portion.

Coordination with ISO activity

In the provisions related to certification procedures, use is made of the related specifications developed by the International Organization for Standardization (ISO). In most cases, these specifications have been incorporated by direct reference. However, in some cases it has been found necessary to modify the specifications to suit ICAO requirements and in such cases the modified material is included in full in this document. The assistance provided by ISO in the development of detailed specifications is recognised.

TABLE OF CONTENTS

...

CHAPTER 3. Turbojet and turbofan engines intended for propulsion at supersonic speeds.....	III-3-1
3.1 General.....	III-3-1
3.2 Smoke	III-3-3
3.3 Gaseous emissions	III-3-3
3.4 Information required	III-3-3

CHAPTER 4. Particulate matter emissions	III-4-1
---	---------

4.1 General	III-4-1
4.2 Non-Volatile Particulate Matter Emissions	III-4-2
4.3 Information required	III-4-3

Part IV. NON-VOLATILE PARTICULATE MATTER ASSESSMENT FOR INVENTORY AND MODELLING PURPOSES.....	IV-1-1
--	---------------

APPENDICES

APPENDIX 1. Measurement of reference pressure ratio	APP 1-1
1. General	APP 1-1
2. Measurement	APP 1-1

...

Attachment C to Appendix 3. Specification for NO_x NO_x analyser	APP 3-17
--	----------

.

...

APPENDIX 6. Compliance procedure for gaseous emissions and smoke	APP 6-1
1. General	APP 6-1
2. Compliance procedures	APP 6-1
3. Procedure in the case of failure	APP 6-2

APPENDIX 7. Instrumentation and measurement techniques for non-volatile particulate matter emissions... APP 7-1	APP 7-1
---	---------

1. Introduction	APP 7-1
2. Definitions, acronyms and symbols	APP 7-1
3. Data required	APP 7-5
4. General arrangement of the nvPM sampling and measurement system	APP 7-6
5. General test procedure	APP 7-12
6. Calculations	APP 7-16

Attachment A to Appendix 7. Requirements and recommendations for nvPM sampling system	APP 7-21
---	----------

Attachment B to Appendix 7. Specification for nvPM mass instrument and calibration	APP 7-26
--	----------

Attachment C to Appendix 7. Specifications and calibration for the volatile particle remover and the nvPM number instrument APP 7-35

Attachment D to Appendix 7. Specifications for additional data APP 7-39

Attachment E to Appendix 7. Procedures for system operation APP 7-40

APPENDIX 8. Procedures for estimating nvPM system losses correctionsAPP 8-1

1. General APP 8-

2. Definition, acronyms, and symbols.....APP 8-

3. Correction factors for nvPM mass and number EIs APP 8-

4. Procedure to estimate engine exit exhaust nozzle exit plane mass and number concentrations corrected for system losses..... APP 8-

5. Overall system penetration fractions APP 8-

6. Procedure to determine penetration fractions of individual components of nvPM sampling and measurement system APP 8-

...

Table A. Amendments to Annex 16

...

4	Fourth Meeting of the Committee on Aviation Environmental Protection	Increased stringency of NO_x NO_x emissions limits.	26 February 1999 19 July 1999 4 November 1999
5	Sixth Meeting of the Committee on Aviation Environmental Protection	Increase in stringency of the NO_x NO_x emissions Standards.	23 February 2005 11 July 2005 24 November 2005

...

INTERNATIONAL STANDARDS AND RECOMMENDED PRACTICES

PART I. DEFINITIONS AND SYMBOLS

CHAPTER 1. DEFINITIONS

...

Derivative version. An aircraft gas turbine engine of the same generic family as an originally type-certificated engine and having features which retain the basic core engine and combustor design of the original model and for which other factors, as judged by the certifying authority, have not changed.

Note.— Attention is drawn to the difference between the definition of A⁶ “derived version of an aeroplane⁶” in Volume I of Annex 16 and the definition of A⁶ “derivative version⁶” in this Volume.

...

Exhaust nozzle. In the exhaust emissions sampling of gas turbine engines where the jet effluxes are not mixed (as in some turbofan engines for example) the nozzle considered is that for the gas generator (core) flow only. Where, however, the jet efflux is mixed the nozzle considered is the total exit nozzle.

...

Non-Volatile Particulate Matter (nvPM). Emitted particles that exist at gas turbine engine exhaust nozzle exit plane that do not volatilise when heated to a temperature of 350°C.

...

Type Certificate. A document issued by a Contracting State to define the design of an aircraft, engine or propeller type and to certify that this design meets the appropriate airworthiness requirements of that State.

Note.— In some Contracting States a document equivalent to a type certificate may be issued for an engine or propeller type.

CHAPTER 2. SYMBOLS

...

NO₂ Nitrogen dioxide

NO_x NO_x Oxides of nitrogen (*see* definition)

nvPM Non-Volatile Particulate Matter

SN Smoke Number (*see* definition)

...

PART III. EMISSIONS CERTIFICATION

CHAPTER 1. ADMINISTRATION

1.1 The provisions of 1.2 to 1.4 1.5 shall apply to all engines and their derivative versions included in the classifications defined for emission certification purposes in Chapters 2 and 3 and 4 where such engines are fitted to aircraft engaged in international air navigation.

...

CHAPTER 2. TURBOJET AND TURBOFAN ENGINES INTENDED FOR PROPULSION ONLY AT SUBSONIC SPEEDS

...

2.1.2 Emissions involved

The following emissions shall be controlled for certification of aircraft engines:

Smoke

Gaseous emissions

Unburned hydrocarbons (HC);

Carbon monoxide (CO); and

Oxides of nitrogen (~~NO_x~~ NO_x).

2.1.3 Units of measurement

2.1.3.1 The smoke emission shall be measured and reported in terms of Smoke Number (SN).

2.1.3.2 The mass (D_p) of the gaseous pollutant HC, CO, or ~~NO_x~~ NO_x emitted during the reference emissions landing and take-off (LTO) cycle, defined in 2.1.4.2 and 2.1.4.3, shall be measured and reported in grams.

2.1.4 Reference conditions

2.1.4.1 *Atmospheric conditions*

The reference atmospheric conditions for engine performance shall be ISA at sea level except that the reference absolute humidity shall be 0.00634 kg water/kg dry air.

...

2.1.4.3 *Reference emissions landing and take-off (LTO) cycle*

The reference emissions LTO cycle for the calculation and reporting of gaseous emissions shall be represented by the following time in each operating mode.

<i>Phase</i> LTO operating mode	Time in operating mode, minutes
Take-Off	0.7
Climb	2.2

Approach	4.0
Taxi/ground idle	26.0

...

2.3.2 Regulatory levels

Gaseous emission levels when measured and computed in accordance with the procedures of Appendix 3 and converted to characteristic levels by the procedures of Appendix 6, or equivalent procedures as agreed by the certificating authority, shall not exceed the regulatory levels determined from the following formulas:

Hydrocarbons (HC): $D_p / F_{00} = 19.6$

Carbon monoxide (CO): $D_p / F_{00} = 118$

Oxides of nitrogen (~~NO_x~~ NO_x):

...

APPENDIX 2. SMOKE EMISSION EVALUATION

...

2.2.2 Sampling lines shall be as “straight through” as possible. Any necessary bends shall have radii which are greater than 10 times the inside diameter of the lines. The material of the lines shall be such as to discourage build-up of particulate matter or static electricity.

Note.— Stainless steel or ~~carbon-loaded~~ carbon-loaded grounded polytetrafluoroethylene (PTFE) meet these requirements.

2.3 Smoke analysis system

...

APPENDIX 3. INSTRUMENTATION AND MEASUREMENT TECHNIQUES FOR GASEOUS EMISSIONS

...

2. DEFINITIONS

...

Gas Concentration. The volume fraction of the component of interest in the gas mixture — expressed as volume percentage or as parts per million.

...

Parts per million (ppm). The unit volume gas concentration of a gas per million unit volume of the gas mixture of which it is a part.

Parts per million carbon (ppmC). The mole fraction of hydrocarbon multiplied by 10^6 measured on a methane-equivalence basis. Thus, 1 ppm of methane is indicated as 1 ppmC. To convert ppm concentration of any hydrocarbon to an equivalent ppmC value, multiply ppm gas concentration by the number of carbon atoms per molecule of the gas. For example, 1 ppm propane translates as 3 ppmC hydrocarbon; 1 ppm hexane as 6 ppmC hydrocarbon

Reference gas. A mixture of gases of specified and known composition used as the basis for interpreting instrument response in terms of the gas concentration of the gas to which the instrument is responding.

...

Response. The change in instrument output signal that occurs with change in sample gas concentration. ~~Also the output signal corresponding to a given sample concentration.~~

...

3.1 Gaseous emissions

Gas Concentrations of the following emissions shall be determined:

- a) Hydrocarbons (HC): a combined estimate of all hydrocarbon compounds present in the exhaust gas.
- b) Carbon monoxide (CO).
- c) Carbon dioxide (CO₂).

Note.— CO₂ is not a regulated engine emission but its CO₂ concentration is required for calculation and check purposes.

- d) Oxides of nitrogen (~~NO_x~~ NO_x): an estimate of the sum of the two oxides, nitric oxide (NO) and nitrogen dioxide (NO₂).

e) Nitric oxide (NO).

...

3.2 Other information

In order to ~~normalize~~ **normalise** the emissions measurement data and to quantify the engine test characteristics, the following additional information shall be provided:

...

5. DESCRIPTION OF COMPONENT PARTS

...

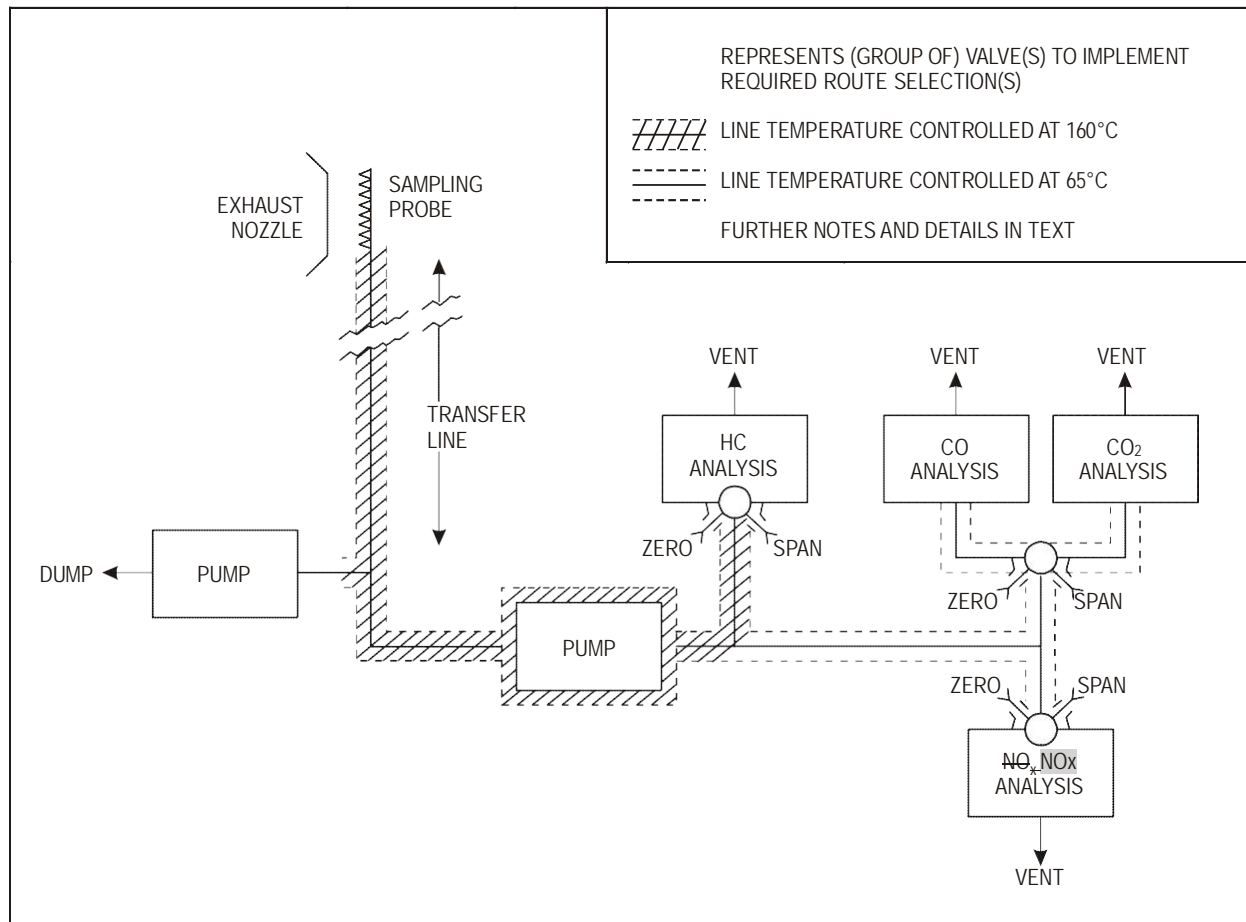

Figure A3-1. Sampling and analysis system, schematic

5.1.2 Sampling lines

The sample shall be transferred from the probe to the analysers via a line of 4.0 to 8.5 mm inside diameter, taking the shortest route practicable and using a flow rate such that the transport time is less than 10 seconds. The line shall be maintained at a temperature of 160°C ±15°C (~~with a stability of ±10°C~~), except for a) the distance required to cool the gas from the engine exhaust temperature down to

the line control temperature, and b) the branch which supplies samples to the CO, CO₂, and NO_x NO_x analysers. This branch line shall be maintained at a temperature of 65°C ±15°C (~~with a stability of ±10°C~~). When sampling to measure HC, CO, CO₂ and NO_x NO_x components the line shall be constructed in stainless steel or carbon-loaded grounded PTFE.

...

5.4 NO_x-NO_x analyser

The measurement of NO gas concentration shall be by the chemiluminescent method in which the measure of the radiation intensity emitted during the reaction of the NO in the sample with added O₃ is the measure of the NO gas concentration. The NO₂ component shall be converted to NO in a converter of the requisite efficiency prior to measurement. The resultant NO_x NO_x measurement system shall include all necessary flow, temperature and other controls and provide for routine zero and span calibration as well as for converter efficiency checks.

Note.— An overall specification is given in Attachment C to this appendix.

...

6.2 Major instrument calibration

...

6.2.3 The procedure for checking the performance of each analyser shall be as follows (using the calibration and test gases as specified in Attachment D to this appendix):

- a) introduce zero gas and adjust instrument zero, recording setting as appropriate;
- b) for each range to be used operationally, introduce calibration gas of (nominally) 90 per cent range full-scale deflection (FSD) gas concentration; adjust instrument gain accordingly and record its setting;
- c) introduce approximately 30 per cent, 60 per cent, and 90 per cent range FSD gas concentration and record analyser readings;
- d) fit a least squares straight line to the zero, 30 per cent, 60 per cent and 90 per cent gas concentration points. For the CO and/or CO₂ analyser used in their basic form without linearization of output, a least squares curve of appropriate mathematical formulation shall be fitted using additional calibration points if judged necessary. If any point deviates by more than 2 per cent of the full scale value (or ±1 ppm, whichever is greater) then a calibration curve shall be prepared for operational use.

6.3 Operation

...

6.3.2 The following procedure shall be adopted for operational measurements:

- a) apply appropriate zero gas and make any necessary instrument adjustments;
- b) apply appropriate calibration gas at a nominal 90 per cent FSD gas concentration for the

ranges to be used, adjust and record gain settings accordingly;

- c) when the engine has been stabilized at the required thrust setting, continue to run it and observe pollutant gas concentrations until a stabilized reading is obtained, which shall be recorded;

...

6.4 Carbon balance check

Each test shall include a check that the air/fuel ratio as estimated from the integrated sample total carbon gas concentration exclusive of smoke, agrees with the estimate based on engine air/fuel ratio ~~within~~ with an accuracy of ± 15 per cent for the taxi/ground idle mode, and ~~within~~ with an accuracy of ± 10 per cent for all other modes (see 7.1.2).

...

7. CALCULATIONS

7.1 Gaseous emissions

7.1.1 General

The analytical measurements made shall be the gas concentrations of the various gaseous emissions, as detected at their respective analysers for a range of combustor inlet temperatures (T_B) encompassing the four LTO operating modes. Using the calculations of 7.1.2, or the alternative methods defined in Attachment E to this appendix, the measured emissions indices (EI) for each gaseous emission shall be established. To account for deviations from reference atmospheric conditions, the corrections of 7.1.3 shall be applied. Note that these corrections may also be used to account for deviations of the tested engine from the reference standard engine where appropriate (see Appendix 6, paragraph 1 f)). Using combustor inlet temperature (T_B) as a correlating parameter, the emissions indices and fuel flow corresponding to the operation at the four LTO operating modes of a reference standard engine under reference day conditions shall then be established using the procedures of 7.2.

7.1.2 Basic parameters

$$EI_p(\text{emission index for component } p) = \frac{\text{mass of } p \text{ produced in } g}{\text{mass of Fuel used in } kg}$$

$$EI(CO) = \left(\frac{[CO]}{[CO_2] + [CO] + [HC]} \right) \left(\frac{10^3 M_{CO}}{M_C + (n/m)M_H} \right) \left(1 + [CO_2] (P_0/m) \right)$$

$$EI(HC) = \left(\frac{[HC]}{[CO_2] + [CO] + [HC]} \right) \left(\frac{10^3 M_{HC}}{M_C + (n/m)M_H} \right) \left(1 + [CO_2] (P_0/m) \right)$$

$$EI(NO_x) \text{ as } NO_2 = \left(\frac{[NO_x]}{[CO_2] + [CO] + [HC]} \right) \left(\frac{10^3 M_{NO_2}}{M_C + (n/m)M_H} \right) \left(1 + [CO_2] (P_0/m) \right)$$

$$\frac{\text{Air}}{\text{Fuel}} \text{ Ratio} = P_0/m \left(\frac{M_{AIR}}{M_C + (n/m)M_H} \right)$$

...

M_{AIR} molecular mass of dry air = 28.966 g or, where appropriate, = $(32 R [O_2]_b + 28.156 4 S [N_2]_b + 44.011 T [CO_2]_b)g$

...

$R [O_2]_b$ gas concentration of O₂ in dry air, by volume = 0.209 5 normally

$S [N_2]_b$ gas concentration of N₂ + rare gases in dry air, by volume = ~~0.709 2~~ 0.790 2 normally

$T [CO_2]_b$ gas concentration of CO₂ in dry air, by volume = 0.000 3 normally

[HC] mean gas concentration of exhaust hydrocarbons vol/vol wet, expressed as carbon

[CO] mean gas concentration of CO in exhaust sample vol/vol, wet

[CO₂] mean gas concentration of CO₂ in exhaust sample vol/vol, wet

~~[NO_xNO_x]~~ mean gas concentration of ~~NO_x~~ NO and NO₂ in exhaust sample vol/vol, wet = [NO + NO₂]

[NO] mean gas concentration of NO in exhaust sample, vol/vol, wet

[NO₂] mean gas concentration of NO₂ in exhaust sample, vol/vol, wet

$$= \frac{([\del{NO_xNO_x}]_c - [NO])}{\eta}$$

~~[NO_xNO_x]~~_c mean gas concentration of NO in exhaust sample after passing through the NO₂/NO converter, vol/vol, wet

...

The value of n/m , the ratio of the atomic hydrogen to atomic carbon of the fuel used, is evaluated by fuel type analysis. The ambient air humidity, h_{vol} , shall be measured at each set condition. In the absence of contrary evidence as to the characterization (x,y) of the exhaust hydrocarbons, the values $x = 1, y = 4$ are to be used. If dry or semi-dry CO and CO₂ measurements are to be used then these shall first be converted to the equivalent wet gas concentration as shown in Attachment E to this appendix, which also contains interference correction formulas for use as required.

...

7.1.3.2 Using the recommended curve fitting technique of 7.2 to relate emission indices to combustor inlet temperature effectively eliminates the $\exp((T_{Bref} - T_B)/c)$ term from the generalized equation and for most cases the (FAR_{ref} / FAR_B) term may be considered unity. For the emissions indices of CO and HC many testing facilities have determined that the humidity term is sufficiently

close to unity to be eliminated from the expression and that the exponent of the (P_{Bref}/P_B) term is close to unity.

Thus,

EI(CO) corrected = EI derived from (P_B/P_{Bref}) " EI(CO) v. T_B curve

EI(HC) corrected = EI derived from (P_B/P_{Bref}) " EI(HC) v. T_B curve

EI(~~NO_x~~NO_x) corrected = EI derived from EI(~~NO_x~~NO_x) $(P_{Bref}/P_B)^{0.5} \exp(19 [h_{mass} - 0.00634])$ v. T_B curve

If this recommended method for the CO and HC emissions index correction does not provide a satisfactory correlation, an alternative method using parameters derived from component tests may be used.

Any other methods used for making corrections to CO, HC and ~~NO_x~~ NO_x emission indices shall have the approval of the certificating authority.

...

ATTACHMENT A TO APPENDIX 3. SPECIFICATION FOR HC ANALYSER

Note 1.— As outlined in 5.2 of Appendix 3, the measuring element in this analyser is the flame ionization detector (FID) in which the whole or a representative portion of the sample flow is admitted into a hydrogen-fuelled flame. With suitably positioned electrodes an ionization current can be established which is a function of the mass rate of hydrocarbon entering the flame. It is this current which, referred to an appropriate zero, is amplified and ranged to provide the output response as a measure of the hydrocarbon gas concentration expressed as ppmC equivalent.

2. SYNERGISTIC EFFECTS

Note.— In application there are two aspects of performance which can affect the accuracy of measurement:

- a) the oxygen effect (whereby differing proportions of oxygen present in the sample give differing indicated hydrocarbon gas concentration for constant actual HC gas concentrations); and*
- b) the relative hydrocarbon response (whereby there is a different response to the same sample hydrocarbon gas concentrations expressed as equivalent ppmC, dependent on the class or admixture of classes of hydrocarbon compounds).*

The magnitude of the effects noted above shall be determined as follows and limited accordingly.

Oxygen response: measure the response with two blends of propane, at approximately 500 ppmC gas concentration known to a relative accuracy of ± 1 per cent, as follows:

- 1) propane in 10 ± 1 per cent O₂, balance N₂
- 2) propane in 21 ± 1 per cent O₂, balance N₂

If R_1 and R_2 are the respective ~~normalized~~ **normalised** responses then $(R_1 - R_2)$ shall be less than 3 per cent of R_1 .

Differential hydrocarbon response: measure the response with four blends of different hydrocarbons in air, at gas concentrations of approximately 500 ppmC, known to a relative accuracy of ± 1 per cent, as follows:

- a) propane in zero air
- b) propylene in zero air
- c) toluene in zero air
- d) n-hexane in zero air.

If R_a , R_b , R_c and R_d are, respectively, the ~~normalized~~ **normalised** responses (with respect to propane), then $(R_a - R_b)$, $(R_a - R_c)$ and $(R_a - R_d)$ shall each be less than 5 per cent of R_a .

3. OPTIMIZATION OF DETECTOR RESPONSE AND ALIGNMENT

...

3.2 The linearity of each analyser range shall be checked by applying propane in air samples at gas concentrations of approximately 30, 60 and 90 per cent of full scale. The maximum response deviation of any of these points from a least squares straight line (fitted to the points and zero) shall not exceed ± 2 per cent of full scale value. If it does, a calibration curve shall be prepared for operational use.

ATTACHMENT B TO APPENDIX 3. SPECIFICATION FOR CO AND CO₂ ANALYSERS

Note 1.— Paragraph 5.3 of Appendix 3 summarizes the characteristics of the analysis subsystem to be employed for the individual measurements of CO and CO₂ gas concentrations in the exhaust gas sample. The instruments are based on the principle of non-dispersive absorption of infrared radiation in parallel reference and sample gas cells. The required ranges of sensitivity are obtained by use of stacked sample cells or changes in electronic circuitry or both. Interferences from gases with overlapping absorption bands may be minimized by gas absorption filters and/or optical filters, preferably the latter.

...

CO Analyser

...

g) *Interferences:* to be limited with respect to indicated CO gas concentration as follows:

- 1) less than 500 ppm/per cent ethylene gas concentration
- 2) less than 2 ppm/per cent CO₂ gas concentration

...

CO₂ Analyser

...

g) The effect of oxygen (O₂) on the CO₂ analyser response shall be checked. For a change from 0 per cent O₂ to 21 per cent O₂, the response of a given CO₂ gas concentration shall not change by more than 2 per cent of reading. If this limit cannot be met an appropriate correction factor shall be applied.

...

CO and CO₂ Analysers

...

c) *Calibration curves:*

- 1) Analysers with a linear signal output characteristic shall be checked on all working ranges using calibration gases at known gas concentrations of approximately 0, 30, 60 and 90 per cent of full scale. The maximum response deviation of any of these points from a least squares straight line, fitted to the points and the zero reading, shall not exceed ± 2 per cent of the full scale value. If it does then a calibration curve shall be prepared for operational use.
- 2) Analysers with a non-linear signal output characteristic, and those that do not meet the requirements of linearity given above, shall have calibration curves prepared for all working ranges using calibration gases at known gas concentrations of approximately 0,

30, 60 and 90 per cent of full scale. Additional mixes shall be used, if necessary, to define the curve shape properly.

**ATTACHMENT C TO APPENDIX 3. SPECIFICATION FOR ~~NO_x~~NO_x
ANALYSER**

Note.— See Attachment D for information on calibration and test gases.

1. As indicated in 5.4 of Appendix 3, the measurement of the oxides of nitrogen gas concentration shall be by the chemiluminescent technique in which radiation emitted by the reaction of NO and O₃ is measured. This method is not sensitive to NO₂ and therefore the sample shall be passed through a converter in which NO₂ is converted to NO before the measurement of total ~~NO_x~~NO_x is made. Both the original NO and the total ~~NO_x~~NO_x gas concentrations shall be recorded. Thus by difference, a measure of the NO₂ gas concentration shall be obtained.

...

3. The principal performance specification, determined for the instrument operated in an ambient temperature stable to within 2°C, shall be as follows:

a) *Total range:* 0 to 2 500 ppm in appropriate ranges.

...

g) *Interference:* suppression for samples containing CO₂ and water vapour, shall be limited as follows:

- 1) less than 0.05 per cent reading/per cent CO₂ gas concentration;
- 2) less than 0.1 per cent reading/per cent water vapour gas concentration.

...

j) *Converter:* this shall be designed and operated in such a matter as to reduce NO₂ present in the sample to NO. The converter shall not affect the NO originally in the sample.

The converter efficiency shall not be less than 90 per cent.

This efficiency value shall be used to correct the measured sample NO₂ value (i.e. [~~NO_x~~NO_x]_c – [NO]) to that which would have been obtained if the efficiency had not been 100 per cent.

ATTACHMENT D TO APPENDIX 3. CALIBRATION AND TEST GASES

Table of calibration gases

<i>Analyser</i>	<i>Gas</i>	<i>Accuracy*</i>
HC	propane in zero air	±2 per cent or ±0.05 ppm**
CO ₂	CO ₂ in zero air	±2 per cent or ±100 ppm**
CO	CO in zero air	
NO_x NO _x	NO_x NO in zero nitrogen	±2 per cent or ±1 ppm**

* Taken over the 95 per cent confidence interval.

** Whichever is greater.

The above gases are required to carry out the routine calibration of analysers during normal operational use.

Table of test gases

<i>Analyser</i>	<i>Gas</i>	<i>Accuracy*</i>
NO_x NO _x	NO in zero nitrogen	±1 per cent

* Taken over the 95 per cent confidence interval.

The above gases are required to carry out the tests of Attachments A, B and C.

Carbon monoxide and carbon dioxide calibration gases may be blended singly or as dual component mixtures. Three component mixtures of carbon monoxide, carbon dioxide and propane in zero air may be used, provided the stability of the mixture is assured.

Zero gas as specified for the CO, CO₂ and HC analysers shall be zero air (which includes “artificial” air with 20 to 22 per cent O₂ blended with N₂). For the ~~NO_x~~NO_x analyser zero nitrogen shall be used as the zero gas. Impurities in both kinds of zero gas shall be restricted to be less than the following gas concentrations:

- 1 ppm C
- 1 ppm CO
- 100 ppm CO₂
- 1 ppm ~~NO_x~~NO_x

The applicant shall ensure that commercial gases, as supplied, do in fact meet this specification, or are so specified by the vendor.

**ATTACHMENT E TO APPENDIX 3. THE CALCULATION OF THE
EMISSIONS PARAMETERS — BASIS, MEASUREMENT CORRECTIONS AND
ALTERNATIVE NUMERICAL METHOD**

1. SYMBOLS

...

K ratio of gas concentration measured wet to that measured dry (after cold trap)

...

$R [O_2]_b$ gas concentration of O₂ in dry air, by volume = 0.209 5 normally

$S [N_2]_b$ gas concentration of N₂ + rare gases in dry air, by volume = 0.709 2 0.790 2 normally

$T [CO_2]_b$ gas concentration of CO₂ in dry air, by volume = 0.000 3 normally

...

$[CO_2]$ mean gas concentration of CO₂ in exhaust sample vol/vol, wet

$[CO]$ mean gas concentration of CO in exhaust sample vol/vol, wet

$[HC]$ mean gas concentration of exhaust hydrocarbons HC in exhaust sample, vol C/vol wet, expressed as carbon

$[NO]$ mean gas concentration of NO in exhaust sample, vol/vol, wet

$[NO_2]$ mean gas concentration of NO₂ in exhaust sample, vol/vol, wet

$$= \frac{([NO_x]_c - [NO])}{\eta}$$

$[NO_x NO_x]$ mean gas concentration of NO and NO₂ in exhaust sample vol/vol, wet = $[NO + NO_2]$

$[NO_x NO_x]_c$ mean gas concentration of NO in exhaust sample, after passing through the NO₂/NO converter, vol/vol, wet

$$[NO_2] \text{ mean } = \frac{([NO_x]_c - [NO])}{\eta}$$

$[d]$ mean gas concentration in exhaust sample after cold trap, vol/vol

$[m]$ mean gas concentration measurement indicated before instrument correction applied, vol/vol

...

2. BASIS OF CALCULATION OF EI AND AFR PARAMETERS

2.1 It is assumed that the balance between the original fuel and air mixture and the resultant state of the exhaust emissions as sampled can be represented by the following equation:

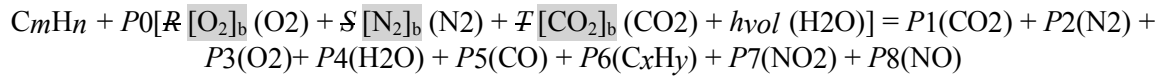

...

$$EI(NO_x, NO_x) = (P_7 + P_8) \left(\frac{10^3 M_{NO_2}}{mM_C + nM_H} \right) \text{ expressed as } NO_2 \text{ equivalent}$$

...

2.2 Values for fuel hydrocarbon composition (m, n) are assigned by fuel specification or analysis. If only the ratio n/m is so determined, the value $m = 12$ may be assigned. The mole fractions of the dry air constituents ($R [O_2]_b, S [N_2]_b, T [CO_2]_b$) are normally taken to be the recommended standard values but alternative values may be assigned, subject to the restriction $R [O_2]_b + S [N_2]_b + T [CO_2]_b = 1$ and the approval of the certifying authority.

...

2.4 Determination of the remaining unknowns requires the solution of the following set of linear simultaneous equations, where (1) to (4) derive from the fundamental atomic conservation relationships and (5) to (9) represent the gaseous product gas concentration relationships.

...

$$m + T [CO_2]_b P_0 = P_1 + P_5 + xP_6 \quad \text{..... (1)}$$

$$n + 2h_{vol}P_0 = 2P_4 + yP_6 \quad \text{..... (2)}$$

$$(2R [O_2]_b + 2T [CO_2]_b + h_{vol})P_0 = 2P_1 + 2P_3 + P_4 + P_5 + 2P_7 + P_8 \quad \text{..... (3)}$$

$$2S [N_2]_b P_0 = 2P_2 + P_7 + P_8 \quad \text{..... (4)}$$

$$\text{..... (4)}$$

$$[NO_x, NO_x] c_{PT} = \eta P_7 + P_8 \quad \text{..... (8)}$$

...

The above set of conditional equations is for the case where all measured gas concentrations are true, that is, not subject to interference effects or to the need to correct for sample drying. In practice, interference effects are usually present to a significant degree in the CO, and NO measurements, and the option to measure CO₂ and CO on a dry or partially dry basis is often used. The necessary modifications to the relevant equations are described in 2.5 and 2.6

...

2.5 The interference effects are mainly caused by the presence of CO₂ and H₂O in the sample which can affect the CO and the NO_xNO_x analysers in basically different ways. The CO analyser is prone to a zero-shifting effect and the NO_xNO_x analyser to a sensitivity change, represented thus:

$$[\text{CO}] = [\text{CO}]_m + L[\text{CO}_2] + M[\text{H}_2\text{O}]$$

$$\text{and } [\text{NO}_x\text{NO}_x]_c = [\text{NO}_x\text{NO}_x]_{cm} (1 + L'[\text{CO}_2] + M'[\text{H}_2\text{O}])$$

which transform into the following alternative equations to (6), (8) and (9), when interference effects require to be corrected,

$$[\text{CO}]_m P_T + LP_1 + MP_4 = P_5 \dots\dots\dots (6A)$$

$$[\text{NO}_x\text{NO}_x]_{cm} (P_T + L'P_1 + M'P_4) = \eta P_7 + P_8 \dots\dots\dots (8A)$$

$$[\text{NO}]_m (P_T + L'P_1 + M'P_4) = P_8 \dots\dots\dots (9A)$$

...

2.6 The option to measure CO₂ and CO gas concentrations on a dry or partially dry sample basis, that is, with a sample humidity reduced to h_d , requires the use of modified conditional equations as follows:

$$[\text{CO}_2]_d (P_T - P_4) (1 + h_d) = P_1 \dots\dots\dots (5A)$$

and

$$[\text{CO}]_d (P_T - P_4) (1 + h_d) = P_5$$

However, the CO analyser may also be subject to interference effects as described in 2.5 and so the complete alternative CO measurement gas concentration equation becomes

$$[\text{CO}]_{md} (P_i - P_4) (1 + h_d) + LP_1 + Mh_d (P_T - P_4) = P_5 \dots\dots\dots (6B)$$

...

3. ANALYTICAL FORMULATIONS

3.1 General

Equations (1) to (10) can be reduced to yield the analytical formulations for the EI and AFR parameters, as given in 7.1 to this appendix. This reduction is a process of progressive elimination of the roots P_0 , P_1 through P_8 , P_T , making the assumptions that all gas concentration measurements are of the “wet” sample and do not require interference corrections or the like. In practice, the option is often chosen to make the CO₂ and CO gas concentration measurements on a “dry” or “semi-dry” basis; also it is often found necessary to make interference corrections. Formulations for use in these various circumstances are given in 3.2, 3.3 and 3.4.

3.2 Equation for conversion of dry gas concentration measurements to wet basis

Gas Concentration wet = $K \times$ gas concentration dry; that is,

$$[] = K []_d$$

The following expression for K applies when CO and CO₂ are determined on a "dry" basis:

$$K = \frac{\{4 + (n/m) F [\text{CO}_2]_b + ([n/m] - F [\text{CO}_2]_b - 2h_{vol}) ([\text{NO}_2] - (2[\text{HC}]/x)) + (2 + h_{vol}) ([y/x] - [n/m]) [\text{HC}]\} (1 + h_d)}{(2 + h) \{2 + (n/m) (1 + h_d) ([\text{CO}_2]_d + [\text{CO}]_d)\} - ([n/m] F [\text{CO}_2]_b - 2h) (1 - [1 + h_d] [\text{CO}]_d)}$$

...

3.3 Interference corrections

The measurements of CO and/or NO_x and NO may require corrections for interference by the sample CO₂ and water concentrations before use in the above analytical equations. Such corrections can normally be expressed in the following general ways:

...

$$\eta[\text{NO}_2] = ([\text{NO}_x]_{cm} - [\text{NO}]_m) (1 + L'[\text{CO}_2] + M'[\text{H}_2\text{O}])$$

...

3.4 Equation for estimation of sample water content

Water concentration in sample

$$[\text{H}_2\text{O}] = \frac{([n/2m] + h_{vol} [P_0/m]) ([\text{CO}_2] + [\text{CO}] + [\text{HC}])}{1 + F [\text{CO}_2]_b (P_0/m)} - (y/2x) [\text{HC}]$$

4. ALTERNATIVE METHODOLOGY — NUMERICAL SOLUTION

4.1 As an alternative to the analytical procedures summarized in 3, it is possible to obtain readily the emissions indices, fuel/air ratio, corrected wet gas concentrations, etc., by a numerical solution of equations (1) to (10) for each set of measurements, using a digital computer.

4.2 In the equation set (1) to (10) the actual gas concentration measurements are substituted using whichever of the alternative equations (5A), (6A), etc. applies for the particular measuring system, to take account of interference corrections and/or dried sample measurements.

...

**ATTACHMENT F TO APPENDIX 3. SPECIFICATIONS FOR
ADDITIONAL DATA**

As required in 3.2 of Appendix 3, in addition to the measured sample constituent **gas** concentrations, the following data shall also be provided:

...

**APPENDIX 4. SPECIFICATION FOR FUEL TO BE USED IN
AIRCRAFT TURBINE ENGINE EMISSION TESTING**

The fuel shall meet the specifications of this Appendix 4, unless a deviation and any necessary corrections have been agreed upon by the certificating authority. Additives used for the purpose of smoke suppression (such as organometallic compounds) shall not be present.

<i>Property</i>	<i>Allowable range of values</i>
Density kg/m ³ at 15°C	780 – 820
Distillation temperature, °C	
10% boiling point	155
– 201	
Final boiling point	235
– 285	
Net heat of combustion, MJ/kg	42.86 – 43.50
Aromatics, volume %	15 – 23
Naphthalenes, volume %	1.0 – 3.5 0.0 - 3.0%
Smoke point, mm	20 – 28
Hydrogen, mass %	13.4 – 14.3
Sulphur, mass %	less than 0.3%
Kinematic viscosity at –20°C, mm ² /s	2.5 – 6.5

APPENDIX 6. COMPLIANCE PROCEDURE FOR GASEOUS EMISSIONS AND SMOKE AND PARTICULATE MATTER EMISSIONS

1. GENERAL

The following general principles shall be followed for compliance with the regulatory levels set forth in Part III, 2.2, 2.3, 3.2 and 3.3 and 4.2:

- a) the manufacturer shall be allowed to select for certification testing any number of engines, including a single engine if so desired;
- b) all the results obtained during the certification tests shall be taken into account by the certification authority;
- c) a total of at least 3 engine tests shall be conducted, so that if a single engine is presented for certification it must be tested at least 3 times;
- d) if a given engine (i) is tested several times, the arithmetic mean value (X_i) of the tests shall be considered to be the mean value for that engine (i). The certification result (\bar{X}) is then the arithmetic mean value of the values (X_i) obtained for each engine tested;
- e) the manufacturer shall provide to the certifying authority, the information specified in Part III, 2.4 or 3.4, 4.2 and/or 4.3 as appropriate;
- f) the engines submitted for testing shall have emissions features representative of the engine type for which certification is sought. However, at least one of the engines shall be substantially configured to the production standard of the engine type and have fully representative operating and performance characteristics. One of these engines shall be declared to be the reference standard engine. The methods for correcting to this reference standard engine from any other engines tested shall have the approval of the national certifying authority. The methods for correcting test results for ambient effects shall be those outlined in paragraph 7 of Appendix 3, or paragraph 7 of Appendix 5, or paragraph 6 of Appendix 7, as applicable.

2. COMPLIANCE PROCEDURES

2.1 Gaseous emissions and smoke number

The certifying authority shall award a certificate of compliance if the mean of the values measured and corrected (to the reference standard engine and reference atmospheric conditions) for all the engines tested, when converted to a characteristic level using the appropriate factor which is determined by the number of engines tested (i) as shown in ~~the table below~~ Table A6-1, does not exceed the regulatory level.

Note.— The characteristic level of the Smoke Number or gaseous emissions is the mean of the values of all the engines tested, and, for gaseous emissions only, appropriately corrected to the reference standard engine and reference atmospheric conditions, divided by the coefficient corresponding to the number of engines tested, as shown in Table A6-1.

2.2 Particulate matter emissions

The certifying authority shall award a certificate of compliance if the mean of the values of the maximum nvPM mass concentration measured and corrected for thermophoretic losses in the Collection Part of the sampling system for all the engines tested, when converted to a characteristic level using the appropriate factor which is determined by the number of engines tested (i) as shown in Table A6-1, does not exceed the regulatory level.

Note.— The characteristic level of the maximum nvPM mass concentration is the mean of the maximum values of all the engines tested, and appropriately corrected for the thermophoretic losses in the Collection Part of the sampling system, divided by the coefficient corresponding to the number of engines tested, as shown in Table A6-1.

2.3 Characteristic level

The coefficients needed to determine the characteristic levels of engine emissions are given in Table A6-1.

Table A6-1. Coefficients to determine characteristic levels of the Smoke Number or gaseous emissions

Number of Engines tested (i)	CO	HC	NO _x	SN	nvPM mass concentration
1	0.814 7	0.649 3	0.862 7	0.776 9	0.776 9
2	0.877 7	0.768 5	0.909 4	0.852 7	0.852 7
3	0.924 6	0.857 2	0.944 1	0.909 1	0.909 1
4	0.934 7	0.876 4	0.951 6	0.921 3	0.921 3
5	0.941 6	0.889 4	0.956 7	0.929 6	0.929 6
6	0.946 7	0.899 0	0.960 5	0.935 8	0.935 8
7	0.950 6	0.906 5	0.963 4	0.940 5	0.940 5
8	0.953 8	0.912 6	0.965 8	0.944 4	0.944 4
9	0.956 5	0.917 6	0.967 7	0.947 6	0.947 6
10	0.958 7	0.921 8	0.969 4	0.950 2	0.950 2
more than 10	$1 - \frac{0.13059}{\sqrt{i}}$	$1 - \frac{0.24724}{\sqrt{i}}$	$1 - \frac{0.09678}{\sqrt{i}}$	$1 - \frac{0.15736}{\sqrt{i}}$	$1 - \frac{0.15736}{\sqrt{i}}$

more than 10	$1 - \frac{0.13059}{\sqrt{i}}$	$1 - \frac{0.24724}{\sqrt{i}}$	$1 - \frac{0.09678}{\sqrt{i}}$	$1 - \frac{0.15736}{\sqrt{i}}$	$1 - \frac{0.15736}{\sqrt{i}}$
--------------	--------------------------------	--------------------------------	--------------------------------	--------------------------------	--------------------------------

3. PROCEDURE IN THE CASE OF FAILURE

Note.— When a certification test fails, it does not necessarily mean that the engine type does not comply with the requirements, but it may mean that the confidence given to the certifying authority in compliance is not sufficiently high, i.e. less than 90 per cent. Consequently, the manufacturer should be allowed to present additional evidence of engine type compliance.

3.1 If an engine type fails a certification test, the certifying authority shall permit the manufacturer, if he/she so wishes, to conduct additional tests on the certification engines. If the total results available still show that the engine type fails the certification requirements, the manufacturer shall be allowed to test as many additional engines as desired. The resulting test results shall then be considered with all previous data.

3.2 If the result is still failure, the manufacturer shall be allowed to select one or more engines for modification. The results of the tests already made on the selected engine(s) while unmodified shall be inspected, and further testing shall be done so that at least three tests are available. The mean of these tests shall be determined for each engine and described as the “unmodified mean”.

3.3 The engine(s) may then be modified, and at least three tests shall be conducted on the modified engine(s), the mean of which shall be described as the “modified mean” in each case. This “modified mean” shall be compared to the “unmodified mean” to give a proportional improvement which shall then be applied to the previous certification test result to determine if compliance has been achieved. It shall be determined before testing of any modified engine is begun that the modification(s) comply with the appropriate airworthiness requirements.

3.4 This procedure shall be repeated until compliance has been demonstrated or the engine type application is withdrawn.

Agenda Item 4: Particulate Matter Standard development**4.1 REPORT OF THE PARTICULATE MATTER TASK GROUP**

4.1.1 The WG3 Co-Rapporteurs reported on the completion of the CAEP/10 tasks pertaining to Particulate Matter (PM) emissions. The first non-volatile particulate matter (nvPM) Standard and associated guidance material was presented to the CAEP/10 meeting for approval. A report on the estimation of engine nvPM mass and number emissions from engines not covered by the proposed nvPM Standard was also provided to CAEP. It was highlighted that WG3 has provided the report on the estimation of nvPM emissions from the other category engines to MDG for the potential future assessment of nvPM emissions contributions from these engine categories.

4.1.2 The WG3 Co-Rapporteurs highlighted that the 2014 CAEP Steering Group meeting (SG2014) agreed to develop a Landing Take-off (LTO) nvPM mass and number Standard for turbofan/turbojet engines greater than 26.7 kN by CAEP/11. It was proposed that further validation of the system loss correction methodology continue in CAEP/11 using the nvPM emissions data from representative engines. A detailed plan was presented which provided details on the establishment of a CAEP/11 LTO based nvPM Standards including potential replacement of the smoke number Standard for engines of rated thrust greater than 26.7 kN.

4.2 PROPOSED NON-VOLATILE PARTICULATE MATTER STANDARD - AMENDMENTS TO ANNEX 16, VOLUME II AND THE ETM, VOLUME II

4.2.1 The Co-Rapporteurs of WG3 presented the stand-alone report on the proposed amendment to Annex 16, Volume II to promulgate a new nvPM certification Standard in Chapter 4, Appendix 7 and associated Attachments A to E. A new Part IV and Appendix 8 are also included on procedures for the estimation of system particle losses.

4.2.2 The new Chapter 4 contains the main elements of the certification requirements, proposed regulatory limit for the nvPM mass concentration and the applicability of the Standard for engines of rated thrust greater than 26.7 kN. Appendix 7 and the associated attachments contain all the certification procedures including the measurement methodology, system operation and instrument calibration. Appendix 7 is based on the Aerospace Information Report (AIR) 6241 published by the SAE Engine Exhaust Measurement Committee (SAE E-31).

4.2.3 Appendix 8 contains the description of the particle loss correction estimation methodology in the sampling measurement system. The sampling system configuration, dimensions and operational parameters recorded during an engine test have to be reported to the Certification Authority in order to prove compliance with Appendix 7. The same information, together with the measured nvPM mass and number concentrations, is used for input into the calculation procedure described in Appendix 8.

4.2.4 The Co-Rapporteurs of WG3 presented the stand-alone report on the proposed amendment to ICAO Doc 9501, *Environmental Technical Manual*, Volume II – *Procedures for Emissions Certification of Aircraft Engines*, related to Chapter 4, Appendix 7 and Attachments A to E pertaining to the proposed CAEP/10 nvPM SARPs.

4.2.5 Several members and observers expressed their support for the proposed CAEP/10 nvPM emissions standard for aircraft engines of rated thrust greater than 26.7 kN, and the procedures for the estimation of system losses. The members committed to the development of an LTO based nvPM mass and number standard during CAEP/11, and supported the work plan to assess the options for the replacement of the smoke number visibility standard for aircraft engines of rated thrust greater than 26.7 kN with a future nvPM mass and number standard that would preserve the invisible plume requirements of the smoke number standard. The members and observers presented a summary of information explaining the nvPM proposed amendments to Annex 16 Volume II, and it was requested that this be included within the Appendix of the CAEP/10 report for this agenda item in order to support the implementation of the proposed nvPM Standard into legislative frameworks.

4.2.6 A member provided full support for the promulgation of the new nvPM emissions certification requirement, the initial nvPM Standard set at the smoke visibility limit, and the procedures for the estimation of system losses for reporting purposes for engines of rated thrust greater than 26.7 kN. The member supported the replacement of the smoke number visibility Standard during CAEP/11 with a future LTO-based nvPM mass and number health-based standard that would preserve the invisible plume requirements of the smoke number Standard. The member encouraged engine manufacturers to submit their respective nvPM emissions information to ICAO's Engine Emissions Databank, which will lead to better characterization of air quality health and climate impacts of aviation.

4.2.7 An observer highlighted that it had put considerable effort and resources into the development of the proposed CAEP/10 nvPM Standard and would continue to support the CAEP work programme going forward. The observer emphasised that there would be a significant amount of work required to achieve the proposed CAEP/11 LTO nvPM Standards for mass and number emissions. A commitment has been made by the manufacturers to measure 25 representative engines by February 2017, and it is believed that the majority of these engines will be measured and data reported for this target date enabling the considerations to go forward. Of the 25 engines, there remain a few that as of yet do not have funding but negotiations are ongoing.

4.2.8 An observer highlighted that establishing an engine nvPM emission Standard to replace the existing smoke number Standard should be one of the top priorities for the CAEP/11 work cycle. The nvPM Standard may provide significant air quality benefits, have climate co-benefits in the form of reduced climate forcing associated with black carbon emissions, and could inform action under consideration by other authorities investigating black carbon emissions from vehicle engines, notably the International Maritime Organization (IMO). The observer looked forward to supporting policy development throughout the CAEP/11 cycle.

Discussion and Conclusions

4.2.9 The meeting discussed the equipment used in the measurement on nvPM measurements. It was clarified that the current Annex 16, Volume II gaseous emissions measurement probe and rake will be used in the nvPM measurements, but the nvPM sampling train is different to that used for gaseous emissions and this has required additional investment from States and industry.

4.2.10 Following a question from a member on whether the proposed CAEP/10 nvPM Standard is of a transitional nature, it was clarified that it is in fact a full regulatory standard, based on the current Smoke Number regulatory level. This can be seen as the first step in setting a more stringent regulatory level for nvPM during CAEP/11, which will involve, as part of the standard setting process, defining stringency options and technology responses for aircraft engines. It was highlighted that the work on the CAEP/11 nvPM Standard will be challenging and there are clear milestones, including the submission of

nvPM data from the manufacturers. So that the final result is not jeopardised, WG3 will need to ensure that the milestones are met in a timely manner.

4.2.11 A member requested more details on when the smoke number Standard will be removed following the introduction of the CAEP/11 nvPM Standard for engines greater than 26.7kN. It was clarified that WG3 will work to better understand the confidence level that nvPM measurements uphold the visibility criteria of the current smoke number Standard. Once this has been established, and the nvPM Standard is in place, then proposals will be made to remove the smoke number Standard for engines greater than 26.7kN. The meeting noted that the current smoke number Standard also covers engines <26.7kN.

4.2.12 The meeting thanked the members and observers involved in the nvPM work for the significant resources and dedication. The meeting acknowledged that WG3 has developed an aircraft engine based nvPM mass and number methodology for application as a nvPM mass and number emissions certification requirement. The meeting agreed that the nvPM mass and number emission indices reported as part of the CAEP/10 certification requirement will be used in the development of a new LTO based metric system during CAEP/11 for both nvPM mass and number emissions.

4.2.13 The meeting thanked WG3 for completing its nvPM work during this CAEP cycle, and took note of the significant work conducted by WG3 to develop the new CAEP/10 nvPM Standard based on visibility criterion. As such, the meeting approved the amendments to Annex 16, Volume II, including Chapter 4 and Appendix 7 with Attachments A to E, and Part IV with Appendix 8 on the procedures for the estimation of system losses, as presented in Appendix A to this meeting report. In approving the associated proposed amendments to the ETM, Volume II (pertaining to the new Chapter 4, Appendix 7 and Attachments A to E of Annex 16, Volume II) as presented in the report from the working group, the meeting recognised the work conducted by WG3 to provide guidance material in support of the new nvPM Standard.

4.2.14 The meeting noted the progress toward a CAEP/11 mass and number Standard for turbofan/turbojet engines greater than 26.7kN. The meeting agreed to work towards the retirement of the smoke Standard and replacement with an updated nvPM mass concentration based standard at CAEP/11.

4.2.15 The meeting acknowledged the work of the engine manufacturers in developing the nvPM Standard and encouraged them to submit their respective nvPM emissions information to the PMTG PM Values Database to support the CAEP/11 standard setting process, and once certified, to include nvPM emissions information to the ICAO Engine Emissions Databank.

4.2.16 To aid States in the implementation of the new CAEP/10 nvPM Standard, the meeting approved the summary of information explaining the nvPM proposed amendments to Annex 16, Volume II, as indicated in Appendix B to this Agenda Item.

4.2.17 Recommendations

4.2.17.1 In light of the foregoing discussion, the meeting developed the following recommendations:

RSPP

Recommendation 4/1 — Amendments to Annex 16 — *Environmental Protection, Volume II — Aircraft Engine Emissions*, to introduce the new CAEP/10 nvPM SARPs

That Annex 16, Volume II be amended to introduce the new non-volatile Particle Matter (nvPM) SARPs as indicated in Appendix A to the report on this agenda item.

Recommendation 4/2 — Amendments to the Environmental Technical Manual, Volume II – *Procedures for the Emissions Certification of Aircraft Engines*, associated with the new CAEP/10 nvPM SARPs

That the Environmental Technical Manual, Volume II be amended and published, and revised versions approved by subsequent CAEP Steering Group Meetings be made available free of charge on the ICAO website, pending a final decision on official publication by the ICAO Secretary General.

APPENDIX A**PROPOSED AMENDMENTS TO ANNEX 16, VOLUME II**

The text of the amendment is arranged to show deleted text with a line through it and new text highlighted with grey shading, as shown below:

1. ~~Text to be deleted is shown with a line through it.~~ text to be deleted
2. **New text to be inserted is highlighted with grey shading** new text to be inserted
3. ~~Text to be deleted is shown with a line through it~~ followed by the replacement text which is highlighted with grey shading. new text to replace existing text

**TEXT OF PROPOSED AMENDMENT TO THE
INTERNATIONAL STANDARDS AND RECOMMENDED PRACTICES
ENVIRONMENTAL PROTECTION
ANNEX 16
TO THE CONVENTION ON INTERNATIONAL CIVIL AVIATION
VOLUME II
AIRCRAFT ENGINE EMISSIONS**

CHAPTER 4. PARTICULATE MATTER EMISSIONS

4.1 General

4.1.1 Applicability

The provisions of this chapter shall apply to all aircraft engines, intended for propulsion only at subsonic speeds, for which an application for type certification is submitted to the certifying authority. Specific provisions for the relevant engine categories shall apply as detailed in section 4.2.

4.1.2 Emissions involved

The purpose of this section is to control non-volatile particulate matter mass (nvPM_{mass}) emissions.

4.1.3 Units of measurement

The concentration of nvPM mass (nvPM_{mass}) shall be reported in $\mu\text{g}/\text{m}^3$.

4.1.4 Reference conditions

4.1.4.1 Atmospheric conditions

The reference atmospheric conditions for the reference standard engine shall be ISA at sea level except that the reference absolute humidity shall be 0.00634 kg water/kg dry air.

4.1.4.2 Reference emissions landing and take-off (LTO) cycle

The engine shall be tested at sufficient thrust settings to define the nvPM emissions of the engine so that nvPM mass emission indices (EI_{mass}) and nvPM number emission indices (EI_{num}) can be determined at the following specific percentages of rated thrust and at thrusts producing maximum nvPM_{mass} concentration, maximum EI_{mass} and maximum EI_{num} as agreed by the certifying authority:

<i>LTO operating mode</i>	<i>Thrust setting</i>
---------------------------	-----------------------

Take-off	100 per cent F_{oo}
Climb	85 per cent F_{oo}
Approach	30 per cent F_{oo}
Taxi/ground idle	7 per cent F_{oo}

4.1.4.3 Fuel specifications

The fuel used during tests shall meet the specifications of Appendix 4.

4.1.5 Test conditions

4.1.5.1 The tests shall be made with the engine on its test bed.

4.1.5.2 The engine shall be representative of the certificated configuration (*see* Appendix 6); off-take bleeds and accessory loads other than those necessary for the engine's basic operation shall not be simulated.

4.1.5.3 When test conditions differ from the reference atmospheric conditions in 4.1.4.1, EI_{mass} and EI_{num} shall be corrected to the engine combustor inlet temperature under the reference atmospheric conditions by the method given in Appendix 7.

4.1.5.4 The maximum $nvPM_{mass}$ concentration and EI_{mass} and EI_{num} shall be corrected for thermophoretic losses in the Collection Part of the sampling system by the method given in Appendix 7.

4.2 Non-Volatile Particulate Matter Emissions

4.2.1 Applicability

The provision further specified in 4.2.2 and 4.2.3 shall apply to all turbofan and turbojet engines of a type or model, and their derivative versions, with a rated thrust greater than 26.7 kN and whose date of manufacture of the individual engine is on or after 1 January 2020.

4.2.2 Regulatory Levels

The maximum $nvPM_{mass}$ concentration [$\mu\text{g}/\text{m}^3$] obtained from measurement at sufficient thrust settings, in such a way that the emission maximum can be determined, and computed in accordance with the procedures of Appendix 7 and converted to characteristic levels by the procedures of Appendix 6, or equivalent procedures as agreed by the certificating authority shall not exceed the level determined from the following formula:

$$\text{Regulatory limit concentration of } nvPM_{mass} = 10^{(3 + 2.9 F_{oo}^{-0.274})}$$

4.2.3 Reporting Requirement

The manufacturer shall report the following values of $nvPM$ emissions measured and computed in accordance with the procedures of Appendix 7, or any equivalent procedures as agreed by the certificating authority:

- characteristic level for the maximum $nvPM_{mass}$ concentration ($\mu\text{g}/\text{m}^3$)
- fuel flow (kg/s) at each thrust setting of the LTO cycle
- EI_{mass} (mg/kg of fuel) at each thrust setting of the LTO cycle
- EI_{num} (particles/kg of fuel) at each thrust setting of the LTO cycle
- maximum EI_{mass} (mg/kg of fuel)

- f) maximum EI_{num} (particles/kg of fuel)

4.3 Information required

Note.— The information required is divided into three groups: 1) general information to identify the engine characteristics, the fuel used and the method of data analysis; 2) the data obtained from the engine test(s); and 3) the results derived from the test data.

4.3.1 General information

The following information shall be provided for each engine type for which emissions certification is sought:

- a) engine identification;
- b) rated output (in kN);
- c) reference pressure ratio;
- d) fuel specification reference;
- e) fuel hydrogen/carbon ratio;
- f) the methods of data acquisition;
- g) the method of making corrections for thermophoretic losses in the Collection Part of the sampling system; and
- h) the method of data analysis.

4.3.2 Test information

For each test the following information shall be reported:

- a) net heat of combustion (MJ/kg);
- b) fuel hydrogen content (mass %);
- c) fuel total aromatics content (volume %);
- d) fuel naphthalenes (volume %); and
- e) fuel sulfur (mass %).

...

APPENDIX 7. INSTRUMENTATION AND MEASUREMENT TECHNIQUES FOR NON-VOLATILE PARTICULATE MATTER EMISSIONS

1. INTRODUCTION

Note.— The procedures in this appendix provide guidelines for the acquisition of representative turbine engine non-volatile particulate matter (nvPM) exhaust samples, and their transport to, and analysis by, the nvPM sampling and measurement system. The procedures do not apply to engines employing afterburning.

Any equivalent procedures to those contained in this appendix shall only be allowed after prior application to and approval by the certificating authority.

2. DEFINITIONS, ACRONYMS AND SYMBOLS

2.1 Definitions

Where the following expressions are used in this appendix, they have the meanings ascribed to them below:

Accuracy. The closeness with which a measurement approaches the true value established independently.

Aerodynamic diameter of a particle. The diameter of an equivalent sphere of unit density with the same terminal settling velocity as the particle in question, also referred to as “classical aerodynamic diameter”.

Calibration gas. A high accuracy reference gas to be used for alignment, adjustment and periodic checks of instruments.

Catalytic Stripper (CS). A catalytic device that removes volatile species through oxidation.

Competent laboratory. A testing and calibration laboratory which establishes, implements and maintains a quality system appropriate to the scope of its activities, in compliance with the International Organization for Standardization standard ISO/IEC 17025:2005, as amended from time to time, or equivalent standard and for which the programme for calibration of equipment is designed and operated so as to ensure that calibrations and measurements made by the laboratory are traceable to the International System of Units (SI). Formal accreditation of the laboratory to ISO/IEC 17025:2005 is not required.

Cyclone separator. Separation of particles larger than a prescribed aerodynamic diameter via rotational and gravitational means. The specified cut-point aerodynamic diameter is associated with the percent of particles of a particular size that penetrate through the cyclone separator.

Electrical mobility diameter of a particle. The diameter of a sphere that moves with exactly the same mobility in an electrical field as the particle in question.

Elemental carbon (EC). Light absorbing carbon that is not removed from a filter sample heated to 870°C in an inert atmosphere during TOT analysis, excluding char.

Gas concentration. The volume fraction of the component of interest in the gas mixture.

Non-Volatile Particulate Matter (nvPM). Emitted particles that exist at gas turbine engine exhaust nozzle exit plane that do not volatilise when heated to a temperature of 350°C.

Organic carbon (OC). Carbon volatilised in Helium while heating a quartz fibre filter sample to 870°C during TOT analysis. Includes char formed during pyrolysis of some materials.

Particle loss. The loss of particles during transport through a sampling system. This loss is due to various deposition mechanisms, some of which are size dependent.

Particle mass concentration. The mass of particles per unit volume of sample.

Particle mass emission index. The mass of particles emitted per unit of fuel mass used.

Particle number concentration. The number of particles per unit volume of sample.

Particle number emission index. The number of particles emitted per unit of fuel mass used.

Particle size distribution. List of values or a mathematical function that represents particle number concentration according to size.

Parts per million (ppm). The unit volume concentration of a gas per million unit volume of the gas mixture of which it is part.

Penetration fraction. The ratio of particle concentration downstream and upstream of a sampling system element.

Repeatability. The closeness with which a measurement upon a given, invariant sample can be reproduced in short-term repetitions of the measurement with no intervening instrument adjustment.

Quality system. A management system in which the competent laboratory documents its policies, systems, programmes, procedures and instructions to the extent necessary to assure the quality of the test and/or calibration results.

Resolution. The smallest change in a measurement which can be detected.

Response. The change in instrument output signal that occurs with change in sample concentration.

Rise time. The time required for the output signal to pass from 10 per cent to 90 per cent of the final change in the output signal when a reference material is abruptly applied to the automatic measuring system initially in the basic state. (This term is only applicable for an online analyser.)

Stability. The closeness with which repeated measurements upon a given invariant sample can be maintained over a given period of time.

2.2 Acronyms

CPC	Condensation Particle Counter
FS	Full Scale range of the analyser
GL	Gas Line
HEPA	High efficiency particle air filter, class H13, which removes at least 99.97 per cent of Dioctyl Phthalate particles (0.3 µm in diameter)
ID	Internal diameter
ISA	International Standard Atmosphere (ISO 2533:1975)
LOD	Limit of Detection
NMI	National Metrology Institute
nvPMmi	Non-volatile particulate matter mass instrument
nvPMni	Non-volatile particulate matter number instrument
nvPM	Non-volatile particulate matter (see definition)
PTFE	Polytetrafluoroethylene
slpm	Standard litres per minute (Litres per minute at STP)
STP	Instrument condition at standard temperature 0°C and pressure 101.325 kPa
TOT	Thermal-optical transmission method
VPR	Volatile Particle Remover

2.3 Symbols

[CO]	mean gas concentration of CO in exhaust sample, vol/vol, wet
[CO ₂]	mean gas concentration of CO ₂ in undiluted exhaust sample, vol/vol, wet
[CO ₂] _b	gas concentration of CO ₂ in dry air, by volume = 0.0003
[CO ₂] _{dil1}	mean gas concentration of CO ₂ vol/vol after the first dilution stage, wet
[CO ₂] _{dil2}	mean gas concentration of CO ₂ vol/vol after the second dilution stage, wet
[CO ₂] _s	mean gas concentration of CO ₂ vol/vol in undiluted exhaust as sampled, wet, semi-dry or dry
DF	Dilution Factor = $\frac{\text{Volume of undiluted sample}}{\text{Volume of diluted sample}}$ (Sample concentration before dilution) / (Sample concentration after dilution)
DF ₁	First stage dilution factor = $\frac{[\text{CO}_2]}{[\text{CO}_2]_{\text{dil1}}}$

DF_{1_S}	First stage dilution factor calculated using directly sampled $[CO_2]_S$ and $[CO_2]_{dil1}$
DF_2	Second stage (VPR) dilution factor as per calibration by a Competent Laboratory
D_m	nvPM electrical mobility diameter
D_{xy} , at z nm	Aerodynamic diameter at which xy per cent (detection efficiency) of z size particles are detected
EI_{mass}	nvPM mass emission index corrected for thermophoretic losses, in mg/kg fuel
EI_{num}	nvPM number emission index corrected for thermophoretic losses, in number/kg fuel
[HC]	mean gas concentration of hydrocarbons in exhaust sample, vol/vol, wet, expressed as carbon
$\eta_{VPR}(D_m)$	particle penetration fraction of VPR for particles of D_m
k_{thermo}	Collection Part thermophoretic loss correction factor
[NO]	mean gas concentration of NO in exhaust sample, vol/vol, wet
[NO ₂]	mean gas concentration of NO ₂ in exhaust sample, vol/vol, wet
[NO _x]	mean gas concentration of NO and NO ₂ in exhaust sample, vol/vol, wet = [NO]+[NO ₂]
M_C	Atomic mass of carbon = 12.011
M_H	Atomic mass of hydrogen = 1.008
m	number of C atoms in characteristic fuel molecule
n	number of H atoms in characteristic fuel molecule
$nvPM_{mass}$	nvPM mass concentration at instrument STP condition, corrected for dilution and thermophoretic losses in the collection section of the sampling system, $\mu g/m^3$
$nvPM_{mass_STP}$	Diluted nvPM mass concentration at instrument STP condition, $\mu g/m^3$
$nvPM_{num_STP}$	Diluted nvPM number concentration at instrument STP condition, number/cm ³
T_{line}	Sample line wall temperature
T_1	Diluter1 inlet wall temperature °C
T_{EGT}	Engine measured or performance-derived engine exhaust nozzle exit plane gas temperature °C
t_{90}	90 per cent response time (time between change in inlet concentration and the detector reaching 90 per cent of its final signal)
α	Atomic hydrogen-carbon ratio of the fuel = n/m, where C _m H _n is the equivalent hydrocarbon representation of the fuel used in the test and evaluated by reference to the engine fuel type analysis.

3. **DATA REQUIRED**

3.1 **nvPM Emissions**

3.1.1 In order to calculate the nvPM mass and number emissions, the following concentrations shall be determined:

- a) nvPM Mass: $nvPM_{mass_STP}$
- b) nvPM Number: $nvPM_{num_STP}$
- c) Carbon dioxide (CO₂): $[CO_2]$, and $[CO_2]_{dil}$
- d) Carbon monoxide (CO): $[CO]$
- e) Hydrocarbons (HC): $[HC]$
- f) Oxides of Nitrogen (NO_x): $[NO_x]$, $[NO]$, $[NO_2]$

Note. – Guidance material on the required data is provided in the Environmental Technical Manual (Doc 9501), Volume II – Procedures for the Emissions Certification of Aircraft Engines.

3.1.2 For system operability check purpose, the concentration of the following emission shall be determined:

- Carbon dioxide (CO₂): $[CO_2]_s$

3.2 **Other information**

In order to normalise the emissions measurement data and to define the engine test characteristics, additional information listed in Attachment F to Appendix 3 and Attachment D to this Appendix shall be provided.

4. **GENERAL ARRANGEMENT OF THE NVPM SAMPLING AND MEASUREMENT SYSTEM**

4.1 **nvPM sampling and measurement system**

4.1.1 The nvPM sampling and measurement system shall consist of three parts, divided into five sections:

- a) Collection Part (Section 1)
- b) Transfer Part (Sections 2, 3 and 4)
- c) Measurement Part (Section 5)

Note 1. – An overview description of the nvPM sampling and measurement system is provided in Figure A7-1 and Table A7-1.

Note 2 – More detailed requirements and recommendations for each section of the system are provided in Attachments A, B, C and E to this Appendix.

4.1.2 Sections 1 to 4 shall meet the following requirements:

- a) The sample lines shall be as straight-through as possible.
- b) The total sample line length from probe tip to measurement instrument inlet shall not exceed 35 m. This total length is not equal to the sum of the individual sampling sections maximum allowable lengths. Detailed length requirements are provided in Attachment A to this Appendix and shown in Figure A7-1.

4.1.3 **Recommendation.**— *The following is recommended for Sections 1 to 4:*

- a) *The number of fittings should be minimized and should be manufactured from stainless steel material with a smooth bore.*
- b) *The number of bulkhead union fittings should be minimized and should be thermally insulated to minimize thermal gradients.*

Note. – Guidance material is provided in the Environmental Technical Manual (Doc 9501), Volume II – Procedures for the Emissions Certification of Aircraft Engines.

4.1.4 Sections 2 to 4 shall meet the following requirements:

- a) Any necessary sampling line bends shall have radii greater than 10 times the ID of the line.
- b) There shall not be forward facing step-shoulders greater than 15 per cent of the ID.
- c) Changes in sampling line ID greater than 15 per cent shall only occur at a splitter flow path interface.
- d) Differences in ID of less than or equal to 15 per cent shall be considered as no change.
- e) **Recommendation.**— *The following is recommended for Sections 2 to 4: The sampling line should be actively heated across a fitting. If not practical, the sample line should be heated as close as possible to the next heated element and thermally insulated across the fitting.*

4.2 Collection Part

4.2.1 Section 1 is comprised of the probe/rake hardware and the connection line. It shall meet the following requirements:

- a) The sampling probe material shall be stainless steel or any other non-reactive high temperature material.
- b) If a sampling probe with multiple sample orifices is used, all sampling orifices shall be of equal diameter. The sampling probe design shall be such that at least 80 per cent of the pressure drop through the sampling probe assembly is taken at the orifices.
- c) The number of locations sampled shall not be less than 12.
- d) The sampling plane shall be as close to the engine exhaust nozzle exit plane as permitted by considerations of engine performance but in any case shall be within 0.5 nozzle diameter of the exit plane.

- e) The applicant shall provide evidence to the certificating authority, by means of detailed traverses that the proposed probe design and position does provide a representative sample for each prescribed thrust setting.

Note. – Guidance material on procedures for representative measurements is provided in the Environmental Technical Manual (Doc9501), Volume II – Procedures for the Emissions Certification of Aircraft Engines.

4.3 Transfer Part

4.3.1 At the inlet to Section 2, the Splitter1 assembly shall split the sample into the Transfer Part line, the gas line (GL) for the measurement of undiluted CO₂, CO, HC, NO_x, and the excess sample line.

Note. – This arrangement also allows the GL to be used to measure Smoke Number, if required, as specified in Appendix 2.

4.3.2 The Transfer Part line shall be arranged such that the nvPM sample:

- a) passes through Diluter1, an ejector-type diluter, which draws, dilutes and cools the sample;
- b) passes through Section 3;
- c) passes through a cyclone separator and Splitter2 in Section 4 before entering the Measurement Part in Section 5.

4.4 Measurement Part

4.4.1 nvPM Mass Measurement

The nvPMmi shall meet the requirements in Attachment B to this Appendix.

Each make and model of the nvPMmi shall receive a certificate from the instrument manufacturer or from another competent testing and calibration laboratory confirming that the make and model of the nvPMmi meets the performance specifications listed in Table A7-3 of Attachment B to this Appendix.

4.4.2 nvPM Number Measurement

The nvPM number concentration shall be determined using a system consisting of a Volatile Particle Remover (VPR) and a Condensation Particle Counter (CPC) (nvPMni) in series. The VPR includes a dilution system (DF₂) and a device for the removal of volatile species.

Each make and model of the VPR and CPC shall receive a certificate from the instrument manufacturer or from another competent testing and calibration laboratory confirming that the make and model of each device meets the performance specifications listed in Attachment C to this Appendix.

4.4.3 Make-up flow path

- a) The Make-up flow path shall be used to maintain a constant sample flow rate through Section 3 and provide a diluted sample CO₂ concentration measurement.
- b) The Make-up flow path shall contain a pump, flow controller, and CO₂ analyser.

- c) **Recommendation.**– *A particle filter should be placed upstream of the flow controller to prevent damage to components.*

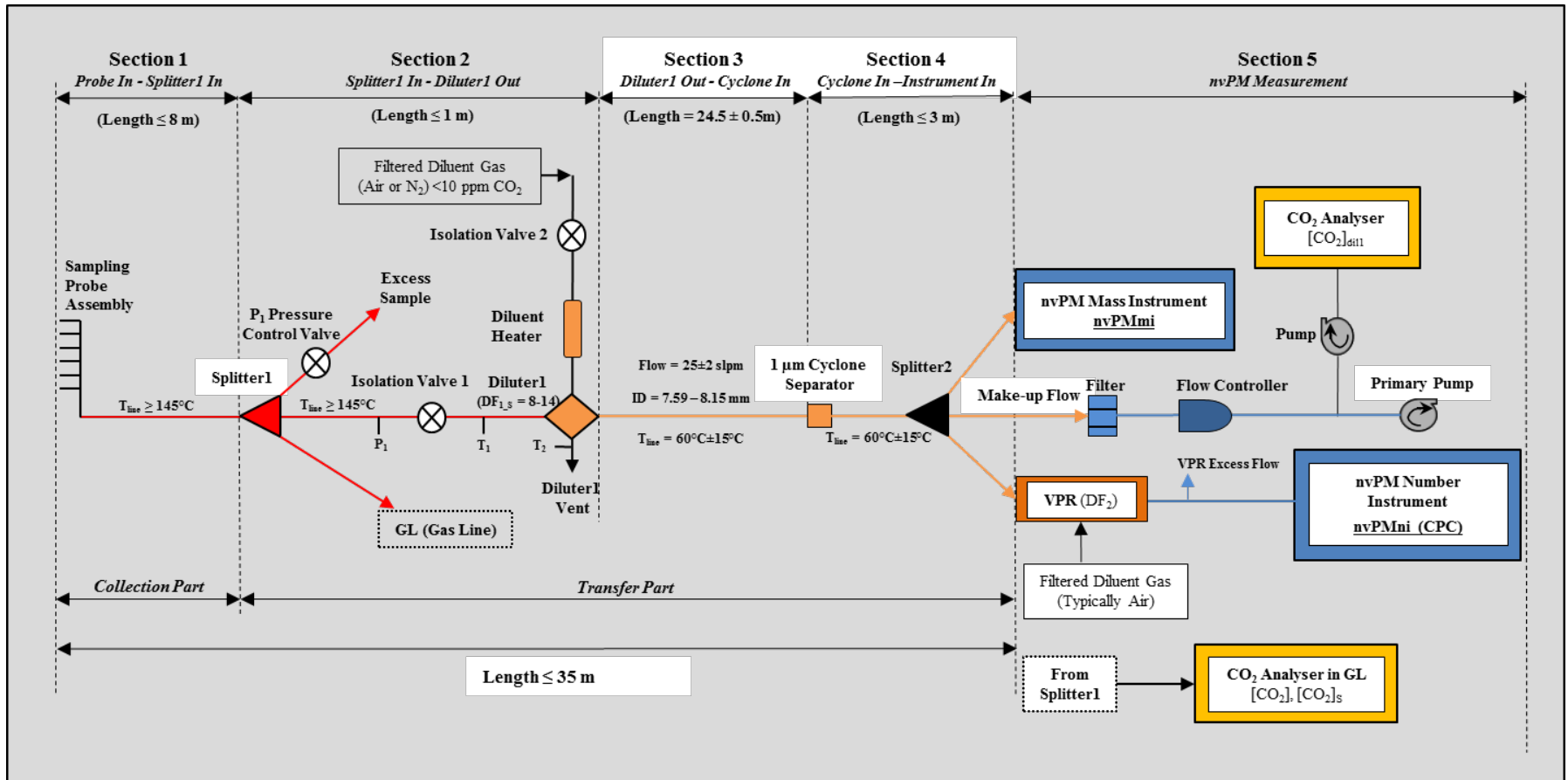

Figure A7-1. Overview schematic of an nvPM sampling and measurement system

Table A7-1. nvPM sampling and measurement system terminology overview

	Terminology	Description
Section 1	Sampling Probe Assembly	Single or multi-point rake hardware used to obtain representative sample from aircraft engine exhaust.
	Connection Line	Length of tubing to transport sample from Probe to Splitter1 inlet.
Section 2	Splitter1	Flow splitter assembly to allow controlled separation of samples to both particle and gas sampling systems. Also provides a flow path (excess sample) to relieve and control sample line pressure.
	P₁ Pressure Control Valve	Valve used to control pressure at Diluter1 inlet.
	P₁	Diluter1 inlet pressure; regulated by the pressure control valve when P ₁ is above ambient.
	T₁	Sample tube temperature at Diluter1 inlet needed for thermophoretic particle loss calculation in Sections 1 and 2.
	Isolation Valve 1	Allows isolation of the particle system from the GL sample and allows leakage checks of GL (including probe) and cleanliness check of Transfer Part.
	Isolation Valve 2	Diluent shut-off valve for Diluter1.
	Diluter1	Ejector-type diluter, which provides a near ambient pressure to the inlet of Section 3. Dilutes the nvPM sample early in the Transfer Part (first stage dilution, DF ₁) to minimize particle coagulation and reduces sample temperature to minimize thermophoretic losses.
	Filtered Diluent Gas	Compressed gas (Nitrogen or Air) for Diluter1.
	Diluent Heater	Heats the diluent prior to entering the Diluter1. Heater temperature controlled by Diluter1 vent temperature (T ₂).
	Diluter1 Vent	Allows venting of excess diluted sample to atmosphere to maintain near-ambient pressure at Diluter1 exhaust and prevent over pressuring the Transfer Part.
	T₂	Temperature in vent flow to control Diluter1 outlet temperature.
GL		Gas line. Heated section to transport exhaust sample for gaseous emissions measurement.
Section 3	Heated sample line	Standardised sampling section. Allows measurements at a safe distance from the engine.
Section 4	1 µm Cyclone Separator	Removes large particles not generated by combustion and helps to prevent instrumentation blockage.
	Splitter2	Flow splitter assembly to provide sample flow paths for nvPM mass and number concentration measurement and a third flow path to ensure that the total system flow rate in Section 3 is maintained.
Section 5	Filter	Particle filter to prevent blockage and damage to the flow controller.
	Flow Controller	Maintains constant flow rate in Section 3 by controlling make-up flow.

Primary Pump	Provides suction for the make-up flow.
CO₂ Analyser	Measurement of [CO ₂] _{dil} in the diluted sample.
nvPMmi	nvPM mass instrument
VPR (DF₂)	Device that removes volatile species and dilutes further the sample (second stage dilution, DF ₂) prior to the nvPMni.
Filtered Diluent Gas	Diluent gas (Nitrogen or Air) for VPR.
nvPMni (CPC)	nvPM number instrument that is a Condensation Particle Counter.

5. GENERAL TEST PROCEDURE

5.1 Calibration and Maintenance

5.1.1 All instruments shall be maintained conforming to the manufacturer's guidelines.

5.1.2 The nvPM sampling and measurement system

Calibration and maintenance of the nvPM sampling and measurement system shall be performed as follows at least on an annual basis or as recommended by manufacturer:

- a) The cyclone separator collection reservoir shall be emptied and cleaned.
- b) Diluter1 orifice nozzle shall be cleaned.
- c) Make-up flow controller and inlet flow rates for nvPMmi, nvPMni, VPR shall be calibrated by a NMI-traceable flow meter.
- d) **Recommendation.**– All calibrated flow rates should be within 5 per cent FS.
- e) Pressure transducers shall be calibrated by a NMI-traceable pressure transducer.
- f) **Recommendation.**– All calibrated pressure measurements should be within 2 per cent FS.

5.1.3 nvPMmi

- a) The nvPMmi shall be annually calibrated by a competent laboratory to meet the calibration requirements prescribed in Attachment B to this Appendix.
- b) nvPMmi shall demonstrate compliance to performance specifications listed in Table A7-3 of Attachment B to this Appendix after hardware or software changes to the nvPMmi which affects data acquisition and processing.

Note. – Guidance material is provided in the Environmental Technical Manual (Doc 9501), Volume II – Procedures for the Emissions Certification of Aircraft Engines.

5.1.4 VPR

- a) The VPR shall be annually calibrated by a competent laboratory to meet the requirements prescribed in Attachment C to this Appendix.
- b) If the VPR contains a catalytic stripper, its replacement interval shall meet the manufacturer guidelines.

5.1.5 nvPMni (CPC)

- a) The nvPMni shall be annually calibrated by a competent laboratory to meet the calibration requirements prescribed in Attachment C to this Appendix.
- b) The nvPMni working fluid shall be n-butanol and shall be replaced following the manufacturer guidelines.
- c) nvPMni shall demonstrate compliance to performance specifications listed in Attachment C to this Appendix after any hardware or software changes to the nvPMni which affects data acquisition and processing.

Note. – Guidance material is provided in the Environmental Technical Manual (Doc 9501), Volume II – Procedures for the Emissions Certification of Aircraft Engines.

5.1.6 Gas analysers

- a) Calibration of the CO₂, CO, HC and NO_x analysers shall follow Appendix 3 procedures.
- b) The CO₂ impurity of the zero calibration gas for the CO₂ analyser downstream of Diluter1 shall be less than 10 ppm.

Note. – The CO₂ impurity specification for the CO₂ analyser downstream of Diluter1 is different from Attachment D to Appendix 3.

- c) **Recommendation.** – The diluent for Diluter1 should be the same as the zero calibration gas used for the CO₂ analyser.

5.2 Engine operation

5.2.1 The engine shall be operated on a static test facility which is suitable and properly equipped for high accuracy performance testing.

5.2.2 The nvPM emissions tests shall be made at the thrust settings prescribed by the certifying authority. The engine shall be stabilised at each setting.

5.3 Carbon balance

Each test shall include a check that the air/fuel ratio as estimated from the integrated sample total carbon concentration exclusive of smoke, agrees with the estimate based on engine air/fuel ratio with an accuracy of ±15 per cent for the taxi/ground idle mode, and with an accuracy of ±10 per cent for all other modes.

Note. – Guidance material on the use of an equivalent procedure is provided in the Environmental Technical Manual (Doc 9501), Volume II – Procedures for the Emissions Certification of Aircraft Engines.

5.4 Operation of nvPM Sampling and Measurement System

5.4.1 Prior to an engine test series, the following requirements shall be met:

- a) Collection Part leakage and cleanliness checks shall be performed using the procedures described in Attachment E to this Appendix.
- b) A VPR dilution factor (DF_2) check shall be performed as described in Attachment E.

5.4.2 The following procedure shall be adopted for gaseous measurements on the GL and downstream of Diluter1:

- a) Apply appropriate zero calibration gas and make any necessary instrument adjustments.
- b) Apply appropriate calibration gas at a nominal 90 per cent FS concentration to span the ranges to be used, adjust and record gain settings accordingly.

5.4.3 During an engine test series, the following requirements shall be met:

- a) nvPM measurements shall only be taken after all instruments and sample transfer lines are warmed up and stable.
- b) If any component or section of the nvPM sampling system is new, cleaned since last use or used previously for a purpose other than sampling engine exhaust, then the nvPM sampling system shall sample aircraft engine exhaust for a minimum of 30 minutes at any engine power condition prior to obtaining nvPM measurements.

Note. – Removal of soot blockage in the Diluter1 orifice does not constitute a cleaning process as defined in b).

- c) The nvPMmi manufacturer-recommended operability checks shall be performed.
- d) For nvPM number measurements, the following requirements shall be met:
 1. The VPR heated stage is at $350^{\circ}\text{C} \pm 15^{\circ}\text{C}$.
 2. If a catalytic stripper is used in the VPR, the diluent shall contain at least 10 per cent of O_2 .
 3. The nvPMni working fluid is at the level required by the manufacturer.
 4. The nvPMni saturator and the condenser have reached correct operating temperatures.
- e) The nvPMni manufacturer-recommended operability checks shall be performed.
- f) A Transfer Part cleanliness check shall be performed at the beginning and end of an engine test using the procedures described in Attachment E to this Appendix.

Note. – The Transfer Part cleanliness check also serves as an operational nvPM instrumentation zero check.

- g) Ambient nvPM measurements shall be performed at the beginning and end of an engine test using the procedures described in Attachment E to this Appendix.

Note. – The ambient measurement also serves as an operational nvPMni response check.

- h) Gaseous analyser zero and calibration points shall be rechecked at the end of the test and also at intervals not greater than 1 hour during tests. If either has changed by more than ± 2 per cent of FS range, the test shall be repeated after restoration of the instrument to within its specification.
- i) **Recommendation.**– Section 1 back-purging should occur during engine start-up and shut down.

5.4.4 During engine nvPM measurements, the following requirements shall be met:

- a) If P1 is at sub-atmospheric pressure, the P1 Pressure Control Valve shall be closed; and if installed, the optional shut-off valve shall be closed.
- b) Both the GL CO₂ concentration and the CO₂ concentration downstream of Diluter1, [CO₂]_{dil1}, shall be continuously measured and used for validating and controlling DF₁ in real time (DF_{1_s}) to within the range 8 to 14. DF_{1_s} is defined as:

$$DF_{1_s} = \frac{[CO_2]_s}{[CO_2]_{dil1}}$$

Note.— The calculation of DF_{1_s} does not require the CO₂ concentration on a wet basis.

- c) The sample flow rate of 25 slpm ±2 slpm in Section 3 shall be monitored by summation of the make-up flow and the inlet flow rates of the nvPMmi and the VPR.
- d) When the engine operation and measured nvPM and [CO₂]_{dil1} concentrations are stable at the required thrust setting, a minimum of 30 seconds of data shall be averaged and recorded.
- e) If the nvPMmi lacks a sample pressure measurement, the pressure shall be measured at a location between the Splitter2 outlet and the make-up flow inlet, and recorded.
- f) If the nvPMni lacks a sample pressure measurement, the pressure shall be measured at a location between the VPR outlet and nvPMni inlet, and recorded.

6. CALCULATIONS

6.1 nvPM mass concentration and nvPM mass and number emission indices equations

This procedure is used to calculate nvPM mass concentration and nvPM mass and number emission indices (EIs) from aircraft gas turbine engines burning hydrocarbon fuel in air. All equations utilise the nvPM mass concentration and nvPM number concentration at instrument STP conditions. If this is not the case, the user shall follow recommended procedures per the instrument manufacturer to correct the reported concentrations to STP conditions for the instrument.

6.1.1 nvPM mass concentration

The nvPM mass concentration ($nvPM_{mass}$) represents the mass of particles per unit volume of engine exhaust sample corrected for the first stage dilution factor (DF_1) and the Collection Part thermophoretic particle losses. It is calculated using the following equation:

$$nvPM_{mass} = DF_1 \times nvPM_{mass_STP} \times k_{thermo}$$

6.1.2 nvPM mass and number emission indices

The nvPM mass and nvPM number emission indices (EI_{mass} and EI_{num}) represent the mass (in milligrams) and number of engine exhaust particles per mass of fuel burned (in kilograms) corrected for their respective dilution factors and the Collection Part thermophoretic particle losses. They are calculated using the following equations:

$$EI_{mass} = \frac{22.4 \times nvPM_{mass_STP} \times 10^{-3}}{\left([CO_2]_{dil} + \frac{1}{DF_1} ([CO] - [CO_2]_b + [HC]) \right) (M_C + \alpha M_H)} \times k_{thermo}$$

$$EI_{num} = \frac{22.4 \times DF_2 \times nvPM_{num_STP} \times 10^6}{\left([CO_2]_{dil} + \frac{1}{DF_1} ([CO] - [CO_2]_b + [HC]) \right) (M_C + \alpha M_H)} \times k_{thermo}$$

$[CO_2]$, $[CO]$ and $[HC]$ shall be calculated as shown in Attachment E to Appendix 3.

Note 1. – The constant 22.4 used in the EI equations above is the volume of one mole of air in litres at STP conditions rounded to one decimal place.

Note 2. – Guidance material on the use of an equivalent procedure is provided in the Environmental Technical Manual (Doc 9501), Volume II – Procedures for the Emissions Certification of Aircraft Engines.

6.2 Correction factors for nvPM emissions

6.2.1 Correction for nvPM thermophoretic losses in the Collection Part

The correction for nvPM thermophoretic losses in the Collection Part shall be determined using:

$$k_{\text{thermo}} = \left(\frac{T_1 + 273.15}{T_{\text{EGT}} + 273.15} \right)^{-0.38}$$

If $T_{\text{EGT}} < T_1$, then $k_{\text{thermo}} = 1$

Note.— Guidance material is provided in the Environmental Technical Manual (Doc 9501), Volume II – Procedures for the Emissions Certification of Aircraft Engines.

6.3 Control parameter functions

The EI shall be normalised to the combustor inlet temperature of the reference standard engine at ISA sea level conditions.

6.3.1 Definitions

Reference standard engine: An engine substantially configured to the production standard of the engine type, with fully representative operating and performance characteristics.

F_{OO} Rated thrust (see Part I, Chapter 1, Definitions)

F_n Thrust at operating mode n for reported nvPM emissions (kN)

W_f Fuel mass flow rate of the reference standard engine under ISA sea level conditions (kg/s)

W_{f_n} Fuel mass flow rate of the reference standard engine under ISA sea level conditions at LTO operating mode n

T_B Combustor inlet temperature

6.3.2 The nvPM mass and number emission indices (EI) shall be obtained for each LTO operating mode at T_B of the reference standard engine. A minimum of three test points shall be required to define the idle mode. For each LTO operating mode, the corresponding fuel flow under ISA conditions shall be obtained. The following relationships shall be determined under ISA reference conditions for nvPM mass and number emission indices:

- a) between EI and T_B ; and
- b) between W_f and T_B ; and
- c) between F and T_B ;

Note 1.— These are illustrated, for example, by Figure A7-2 a), b) and c).

Note 2.— The relationships b) and c) may be established directly from engine test data, or may be derived from a validated engine performance model.

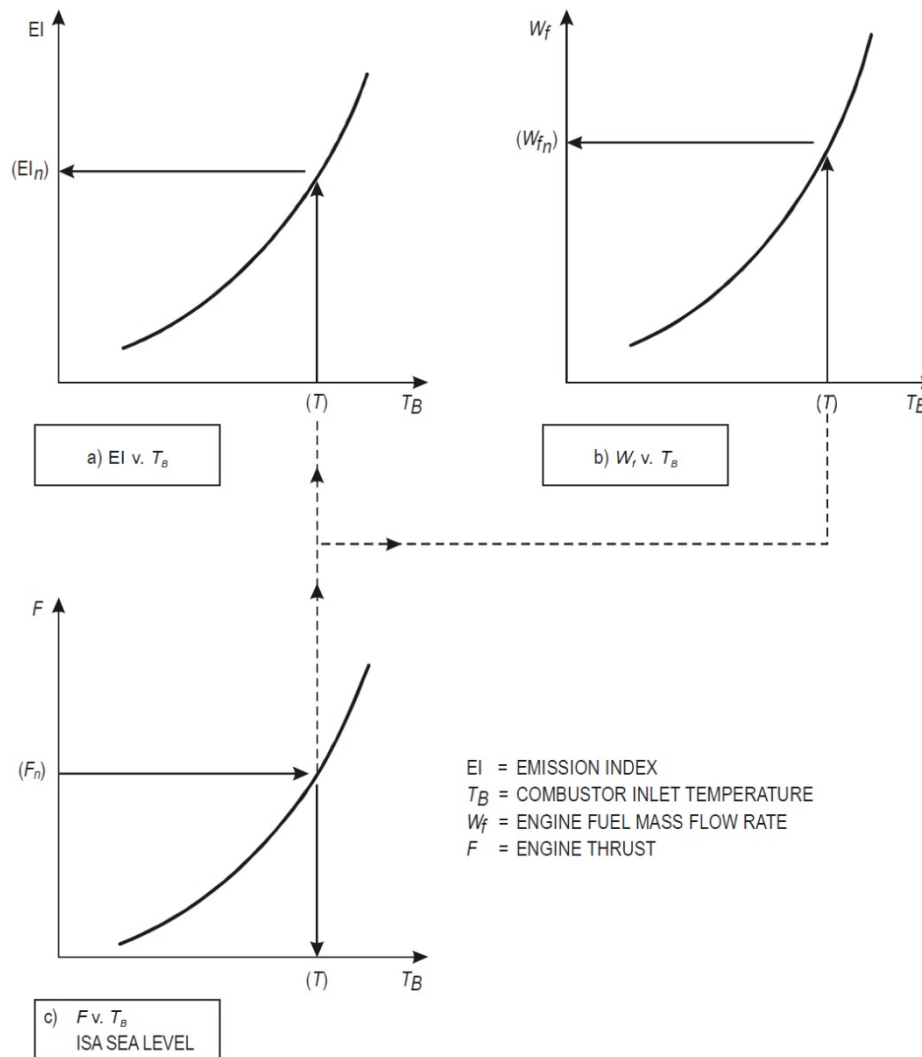

Figure A7-2. Turbine Engine nvPM EI as a function of several engine parameters

6.4 Calculation procedure

The estimation of EI (referenced to T_B) for nvPM mass and number emissions at the reported operating modes shall comply with the following general procedure:

- determine the combustor inlet temperature (T_B) (Figure A7-2 c)) at the values of F_n corresponding to the reported operating modes, n under reference atmospheric conditions;
- from the EI/ T_B characteristic (Figure A7-2 a)), determine the EI_n value corresponding to T_B ;
- from the W_f/T_B characteristic (Figure A7-2 b)), determine the W_f value corresponding to T_B ;

While the methodology described above is the recommended method, the certifying authority may accept equivalent mathematical procedures which utilise mathematical expressions representing the curves illustrated if the expression have been derived using an accepted curve fitting technique.

6.5 Exceptions to the proposed procedures

In those cases where the configuration of the engine or other extenuating conditions exist which would prohibit the use of this procedure, the certificating authority, after receiving satisfactory technical evidence of equivalent results obtained by an alternative procedure, may approve an alternative procedure.

ATTACHMENT A TO APPENDIX 7. REQUIREMENTS AND RECOMMENDATIONS FOR NVPM SAMPLING SYSTEM**1. SECTION 1: PROBE INLET – SPLITTER1 INLET**

1.1 Section 1 shall meet the following requirements:

- a) The sample shall be transferred from the probe to Section 2 via a line of 4.0 to 8.5 mm inside diameter, taking the shortest route practicable.
- b) The sampling line shall be maintained at a temperature greater than or equal to 145°C.
- c) The length from probe inlet to the Splitter1 inlet shall be less than or equal to 8 m.

2. SECTION 2: SPLITTER1 INLET – DILUTER1 OUTLET

2.1 Section 2 shall meet the following requirements:

- a) Section 2 shall contain Splitter1 and Diluter1.
- b) The material of the sample line shall be such as to minimize build-up of particulate matter or static electricity.

Note. – Stainless steel or carbon-loaded electrically grounded polytetrafluoroethylene (PTFE) meet these requirements.

- c) The length of Section 2 from the Splitter1 inlet to the Diluter1 outlet shall not exceed 1 m.
- d) Section 2 shall contain Isolation Valve 1 in order to perform the leakage check on the gas line (GL).

2.2 The Splitter1 shall meet the following requirements:

- a) Splitter1 shall be made of stainless steel.
- b) Splitter1 body temperature shall be maintained at greater than or equal to 145 °C.
- c) Splitter1 shall separate the engine exhaust sample into three flow paths.
- d) The split angles relative to the incoming flow shall be as acute as practical but not exceeding 35°.
- e) The nvPM sample flow path shall be as straight-through and short as practical.
- f) The Splitter1 internal geometry shall meet the following requirements:
 1. No forward facing step-shoulders on the inner wall
 2. No change in ID from Splitter1 outlet to Diluter1 inlet
 3. GL ID = 4 to 8.5 mm
 4. Excess sample line internal cross sectional area shall be greater than or equal to the total inlet area of the probe tips

2.3 The Isolation Valve 1 shall meet the following requirements:

- a) The Isolation Valve 1 shall be placed between Splitter1 outlet and Diluter1 inlet.
- b) The Isolation Valve 1 shall be full bore with no forward facing step-shoulders greater than 15 per cent of the ID.
- c) The seals of the Isolation Valve 1 shall be dry and heat resistant to 175°C.

2.4 The nvPM Section 2 line wall temperature (T₁), to within 5 cm of the Diluter1 mixing plane, shall be maintained at greater than or equal to 145°C as shown in Figure A7-3.

2.5 The Diluter1 shall meet the following requirements:

- a) Diluter1 shall be an ejector-type diluter.
- b) ID of Diluter1 inlet shall be greater than or equal to 7.59 mm.
- c) The diluent flow shall be controlled as specified by the manufacturer.
- d) The real time Diluter1 dilution factor shall be controlled within the range of 8 to 14.

Note 1.– The minimum dilution factor is required to minimize nvPM coagulation, while the maximum is needed to maintain the diluted sample within the measurement range of the instruments.

Note 2.– DF_1 may be adjusted by controlling P_1 with the pressure control valve on the excess sample flow path or by adjusting the diluent gas flow.

- e) The Diluter1 vent shall be open to ambient (equal to engine inlet pressure).
- f) The Diluter1 body shall be heated to 60°C ±15°C as shown in Figure A7-3.
- g) The diluent shall be nitrogen or air, be HEPA filtered and contain less than 10 ppm CO₂.
- h) The diluent shall be heated to provide a diluted nvPM sample temperature of 60 °C ±15 °C at the Diluter1 vent (T₂).
- i) The particle penetration of Diluter1 shall meet the minimum requirements as shown in Table A7-2.
- j) **Recommendation.**– To minimize impact on the operable DF1 range, the Diluter1 vent line pressure drop should be kept to a minimum, as practically possible.
- k) **Recommendation.**– A safety feature should be implemented to prevent the diluent heater from over-heating when the diluent is not flowing.

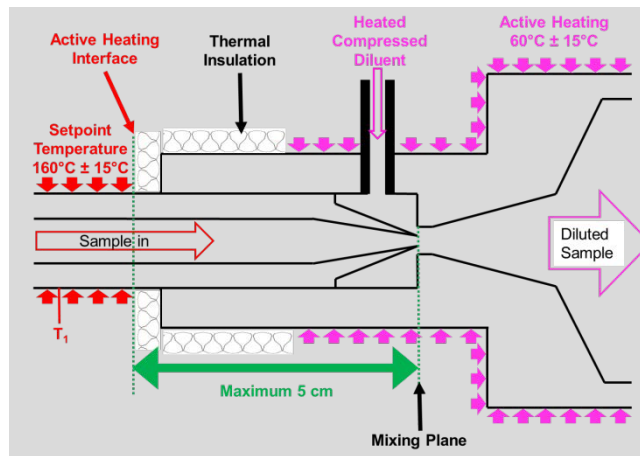

Figure A7-3. Cross section of example ejector-type Diluter1 inlet with heating interface.

Table A7-2: Minimum requirements for particle penetration fractions (transmission efficiencies) of Diluter1

Particle mobility size (diameter)	15 nm	30 nm	50 nm	100 nm
Minimum particle penetration fraction	80 per cent	90 per cent	90 per cent	90 per cent

2.6 Gas Line

2.6.1 The GL and gaseous emissions analysers shall meet the specifications in Appendix 3 and Attachments to Appendix 3.

Note.— The Collection Part (Section 1) of the nvPM sampling and measurement system meets the specifications in Appendix 3.

2.6.2 For nvPM EI determination, GL measurements of CO, HC and NO_x gaseous concentrations shall be performed simultaneously.

Note.— Guidance material is provided in the Environmental Technical Manual (Doc9501), Volume II – Procedures for the Emissions Certification of Aircraft Engines.

2.6.3 For determination of DF_{1,s}, a GL measurement of CO₂ concentration (dry, semi-dry or wet) shall be performed simultaneously with the nvPM measurements.

2.7 Excess sample line

2.7.1 The sample line pressure at Diluter1 inlet (P_1) shall be maintained near local ambient air pressure using a suitable Pressure Control Valve with sufficient internal area. When fully closed, the valve shall be capable of holding a vacuum pressure of -75kPa relative to ambient.

2.7.2 **Recommendation.**— *An optional shut-off valve, with sufficient internal area to avoid system backpressure, should be added downstream of the Pressure Control Valve to prevent leakage at sub-atmospheric conditions inside Splitter1.*

3. SECTION 3: DILUTER1 OUTLET – CYCLONE SEPARATOR INLET

3.1 The sampling line shall meet the following requirements:

- a) The sampling line material shall be carbon-loaded electrically grounded PTFE.
- b) **Recommendation.**— *The sampling line should meet the anti-static specification in ISO 8031.*
- c) The sampling line ID shall be between 7.59 mm and 8.15 mm.

Note.— *Accounting for manufacturing tolerances, the sampling line ID specification corresponds to commercially available line outer diameter dimensions of 3/8 inch and 7/16 inch, both with 0.035 inch wall thickness; and 10 mm with a 1 mm wall thickness.*

- d) The line shall be of length 24.5 m \pm 0.5 m, have no unnecessary fittings and consist of a maximum of three segments.
- e) The coiled sample line bend radii shall be greater 0.5 m.
- f) The sampling line temperature shall be maintained at 60°C \pm 15°C through active heating.
- g) The sample flow shall be maintained at 25 slpm \pm 2 slpm.

4. SECTION 4: CYCLONE SEPARATOR INLET – INSTRUMENT INLET

4.1 Cyclone separator

The cyclone separator shall meet the following requirements:

- a) The cyclone separator material shall be stainless steel.
- b) The cyclone separator shall be heated to 60°C \pm 15°C.
- c) The cyclone separator inlet and outlet IDs shall be less than 15 per cent difference to the inlet and outlet sample line ID.
- d) The performances of the cyclone separator at a sample flow rate of 25 slpm shall meet the following specifications:
 1. Cut-point: $D_{50} = 1.0\mu\text{m} \pm 0.1\mu\text{m}$
 2. Sharpness: $(D_{16}/D_{84})^{0.5}$ less than or equal to 1.25
 3. Pressure-drop: ΔP less than or equal to 2 kPa

4.2 Splitter2

The Splitter2 shall meet the following requirements:

- a) The Splitter2 body material shall be stainless steel
- b) The Splitter2 shall be heated to $60^{\circ}\text{C} \pm 15^{\circ}\text{C}$.
- c) The Splitter2 shall separate the sample into three flow paths to deliver the diluted nvPM sample to:
 1. nvPMmi
 2. VPR
 3. make-up flow
- d) The split angles relative to the incoming flow shall be as acute as practical not exceeding 35° .
- e) All nvPM flow paths shall be as straight-through and short as practical.
- f) The Splitter2 geometry shall meet the following requirements:
 1. No forward facing shoulders on the inner wall
 2. No change in ID from Splitter2 outlet to nvPMmi inlet
 3. No change in ID from Splitter2 outlet to VPR inlet

4.3 Measurement system interface

The sampling lines to the nvPMmi and VPR shall meet the following requirements:

- a) The sampling line material shall be of stainless steel or carbon loaded electrically grounded PTFE.
- b) **Recommendation.** – *If the sampling line is carbon loaded electrically grounded PTFE, it should meet the anti-static specification in ISO 8031.*
- c) The sampling line shall be heated to $60^{\circ}\text{C} \pm 15^{\circ}\text{C}$.
- d) No change in ID between the sampling line and the instrument inlets.
- e) Each total line length from cyclone separator inlet to the inlet of the nvPMmi and VPR shall be kept as short as practical and shall not exceed 3m.

5. SECTION 5: – nvPM MEASUREMENT

5.1 Make-up flow

5.1.1 The Make-up flow path components shall meet the following requirements:

- a) Primary pump and flow controller to maintain a constant total sample flow rate, (flow rate sum of Make-up flow, nvPMmi, and VPR) of $25 \text{ slpm} \pm 2 \text{ slpm}$ up to 10 kPa below ambient, through Section 3;
- b) CO_2 analyser to measure continuously CO_2 concentration downstream of Diluter1 $[\text{CO}_2]_{\text{dil1}}$ during the nvPM measurement.

Note 1.– Depending on the sampling configuration, there may be multiple flow controllers and pumps.

Note 2.– Guidance material is provided in the Environmental Technical Manual (Doc9501), Volume II – Procedures for the Emissions Certification of Aircraft Engines.

- c) **Recommendation.** – *Particle filters should be placed upstream of flow controllers to prevent damage to components.*

5.1.2 If the nvPMmi lacks a sample pressure measurement, the pressure shall be measured at the Splitter2 outlet to the make-up flow path.

5.1.3 The CO₂ analyser shall meet the following requirements:

- a) the CO₂ analyser shall be located after a flow controller;
- b) the CO₂ analyser shall meet the performance specifications given in Attachment B to Appendix 3 Paragraphs “CO and CO₂ Analysers” and “CO₂ Analyser” with the exception of a).
- c) **Recommendation.**– *The CO₂ analyser Total range should be approximately ten times lower than the CO₂ analyser used on the GL.*

ATTACHMENT B TO APPENDIX 7.**SPECIFICATION FOR NVPM MASS INSTRUMENT AND CALIBRATION**

Note 1.– In this Attachment, elemental carbon (EC) mass is being used as a surrogate for nvPM mass. Guidance is provided in the Environmental Technical Manual (Doc9501), Volume II – Procedures for the Emissions Certification of Aircraft Engines.

Note 2.– A full descriptive text for the Thermal Optical Transmittance (TOT) measurement reference method is provided in paragraph 2. This method is commonly performed by calibration laboratories; it is not expected that the aircraft engine manufacturer would perform this method.

Note 3.– The following ISO reference is used in this Attachment: International Standards Organization, Air Quality - Definition and Determination of Performance Characteristics of an Automatic Measuring System. International Standard 9169, 2006

1. SPECIFICATIONS

Each make and model of the nvPMmi shall receive a certificate from the instrument manufacturer or from another competent testing and calibration laboratory confirming that it meets the specifications:

- a) shall have a measurement range of 0 µg/m³ to 1000 µg/m³ or greater;
- b) shall have a resolution of 1 µg/m³ or better;
- c) shall be insensitive to volatile particulate matter;

Note 1.– Volatile particulate matter is combustion exhaust material that volatilises at temperatures less than or equal to 350°C.

Note 2.– This specification is met when the nvPMmi meets the Applicability performance specification in Table A7-3.

- d) shall meet the performance specifications listed in Table A7-3.

Table A7-3 Performance specifications for nvPM mass instruments

Performance Specification	Value (equal or less than)	Determination Method
Repeatability	10 µg/m ³	ISO* 6.4.5.3
Zero drift	10 µg/m ³ /hr	ISO 6.6 (for C ₀ only)
Linearity	15 µg /m ³	ISO* 6.4.5.4
Limit of detection (LOD)	1 µg/m ³	ISO* 6.4.5.5
Rise time	2 seconds	ISO 6.3
Sampling interval	1 second	ISO 2.1.7
Accuracy (Agreement with EC mass)		Slope of the linear regression between nvPMmi mass concentration and EC mass concentration

concentration determined from TOT)	± 10 per cent	determined from TOT after calibration (Table A7-5)
Applicability	±16 per cent	Validation on aircraft turbine exhaust

Note 1.— References to ISO 9169 in the table that are denoted by an asterisk refer to sections for which modifications are applied as described in Paragraph 4 to this Attachment.

Note 2.— The performance specifications reflect the limits of the quantities that can be verified using Thermal-Optical Transmittance (TOT) as the measurement reference method. The TOT method is described in paragraph 2.

Note 3.— Only the Accuracy performance specification is needed and applied in the annual calibration procedure described in paragraph 5 to this Attachment.

Note 4.— Applicability is determined following the procedure provided in Paragraph 3 to this Attachment.

2. THERMAL OPTICAL TRANSMITTANCE (TOT) METHOD

Thermal Optical Transmittance (TOT) shall be the measurement reference method to demonstrate conformity with the performance specifications of each make and model of the nvPMmi and to calibrate the nvPMmi. This method permits the determination of EC and OC in the nvPM samples.

2.1 General

2.1.1 The TOT analyser shall be either a laboratory instrument (with a Flame Ionisation Detector, FID) or semi-continuous instrument (with a Non-Dispersive Infrared detector, NDIR).

2.1.2 The TOT method shall use the temperature profile specified in Table A7-4.

Note.— Guidance material on the TOT method is provided in the Environmental Technical Manual (Doc 9501), Volume II – Procedures for the Emissions Certification of Aircraft Engines.

2.2 Reagents and Materials

2.2.1 The following reagents shall be used:

- a) Aqueous solutions of reagent grade (99 per cent or greater) sucrose, diluted with ultrapure H₂O Type I, or equivalent, to produce 0.1 to 3 mg C per millilitre solution;
- b) He – purity 5.0 (greater than 99.999 per cent);
- c) H₂ – purity 4.5 (greater than 99.995 per cent);
- d) zero air (with less than 0.2 ppm hydrocarbons);
- e) A certified mixture of 10 per cent O₂ in He; and
- f) A certified mixture of 5 per cent CH₄ in He.

2.2.2 The following material shall be used:

- a) For the laboratory instrument, a metal punch provided with the instrument for removal of 1.0 cm² or 1.5 cm² rectangular portion of filter;
- b) For the semi-continuous instrument, a metal punch provided with the instrument for removal of two 2.0 cm² circular filters;
- c) Pall Tissuquartz™ quartz fibre filters, or equivalent; and
- d) Syringe of 10 microlitres

2.2.3 Filter preparation

Depending on the instrument used, the filters shall be prepared as follows:

- a) For manual sampling and analysis, all quartz fibre filters shall be pre-fired in a muffle furnace at or greater than 550°C for 12 hours; or, greater than or equal to 800°C for 1 hour to 2 hours before sampling and stored in a sealed container; or
- b) For the semi-continuous analyser, the filters for measurement shall be conditioned by performing at least one complete measurement cycle as described in Table A7-4.

2.3 Sample Preparation

2.3.1 The sample filter shall be placed on a clean aluminium foil surface.

Note.— Isopropyl alcohol or acetone can be used to clean the foil surface. In this case, allow residual solvent to vaporise from the surface prior to use. Alternatively, the foil can be cleaned by baking in a muffle furnace prior to use.

2.3.2 A representative portion of the filter shall be punched out. Good laboratory practice shall be used in filter handling.

2.4 Calibration and Quality Control

2.4.1 The temperature sensor controlling the oven temperature shall be calibrated using a traceable transfer standard within 1 year prior to any TOT analyses being conducted.

2.4.2 If the laboratory instrument is used, the FID response shall be calibrated. The calibration shall meet the following procedure:

- a) prepare external calibration standard comprised of a sucrose solution in organic-free water;
- b) disperse 10 microlitres of the solution on to punches from a new and clean pre-baked quartz filter;
- c) analyse a minimum of three method blank samples and three sucrose solution samples to ensure that instrument calibration shows a percent recovery of 95 per cent to 105 per cent of the theoretical mass of C (µgC measured/µgC dispersed).

2.4.3 If the semi-continuous instrument is used, the NDIR response shall be calibrated. The calibration shall meet the following procedure:

- a) prepare external calibration standard comprised of a sucrose solution in organic-free water;

- b) disperse 10 microlitres of the solution on to punches from a separate pre-conditioned “boat” filter inserted into the bottom of the quartz semi- tube;
- c) analyse a minimum of three method blank samples and three sucrose solution samples to ensure that instrument calibration shows a percent recovery of 95 per cent to 105 per cent of the theoretical mass of C (μgC measured/ μgC dispersed).

2.4.4 If the filter analyses require more than one day, each day a single quality control check generally using the stock sucrose solution shall be dispersed to the filter and analysed accordingly. The results shall be within 95 to 105 per cent of the theoretical mass of carbon.

Note.– The method blank is a pre-fired quartz filter without addition of sucrose but handled in the same manner.

2.5 Measurement

The measurement shall be obtained using the following procedure:

- a) The TOT analyser shall be operated in accordance with manufacturer’s recommendations.
- b) Place sample portion into sample oven;
- c) Determine EC and OC mass in μg ;

Note.– TOT analyser results are reported in $\mu\text{g}/\text{cm}^2$ of carbon.

- d) Final sample results shall always be blank-corrected:
 1. For the laboratory instrument, the field blank consists of pre-fired quartz fibre filters handled in the same manner as the samples, except that no air is passed through the filter. EC mass loading per unit area greater than or equal to $0.3 \mu\text{g}/\text{cm}^2$ in the blank samples, represents contamination.
 2. For the semi-continuous analyser, a measurement of the internal filter set shall be performed without any sample gas being passed through the filters.
- e) Final sample results shall always be corrected for gas phase OC artefacts. For this correction, the operating conditions (duration and flow rate) shall be identical to those used for sample collection. Depending on the instrument used, the procedure shall be as follows:
 1. For the laboratory analyses, a sampling configuration consisting of a Teflon filter followed by a pre-fired back-up quartz filter, or a pre-fired quartz filter followed by a pre-fired back-up quartz filter, shall be employed with the back-up filter analysed as prescribed in Table A7-4. Any OC found on the back-up filters shall be subtracted from the OC found on sample filters.
 2. For the semi-continuous analyses, a Teflon filter shall be inserted in the sampling configuration prior to the analyser. Any OC found during this measurement shall be subtracted from the OC found during sample measurement.

2.6 Calculations

For the laboratory instrument:

- a) multiply the reported EC loading result ($\mu\text{g}/\text{cm}^2$) by the filter deposit area (cm^2) to calculate total mass of EC (μg) on each filter sample (W_{EC});
- b) do the same calculation as in a) for the blanks and calculate the mass found in the average blank (W_{b}); and
- c) calculate the EC mass concentration (C_{EC}) in the air volume sampled at STP conditions, V (in m^3):

$$C_{\text{EC}} = \frac{W_{\text{EC}} - W_{\text{b}}}{V} \quad (\mu\text{g}/\text{m}^3)$$

Note 1.– The semi-continuous instrument provides the EC mass concentration as a reported result.

Note 2.– Guidance material on the principle of the TOT method is provided in the Environmental Technical Manual (Doc 9501), Volume II – Procedures for the Emissions Certification of Aircraft Engines.

Table A7-4 Required temperature profile for the TOT method analysis cycle.

Carrier Gas	Temperature (°C)	Time at Temperature (seconds)
100 per cent He	310	80
	475	80
	615	80
	870	110
	550	45
10 per cent O ₂ in He	550	45
	625	45
	700	45
	775	45
	850	45
	870	60
	930	120
5 per cent CH ₄ in He	0	120

3. PROCEDURE TO DEMONSTRATE CONFORMITY TO PERFORMANCE SPECIFICATIONS

Note.– The procedure described in this paragraph is used to demonstrate the conformity to the performance specifications of each make and model of the nvPMmi.

The performance specifications listed in Table A7-3 shall be demonstrated using the TOT method as described in paragraph 2. The measurements shall be performed using the two following sources: a diffusion flame combustion aerosol source and a gas turbine engine exhaust nvPM source.

3.1 Measurement using a diffusion flame combustion aerosol source

3.1.1 The measurement system shall contain:

- a) a diffusion flame combustion aerosol source
- b) a dilution system using HEPA filtered diluent to control target EC mass concentrations
- c) a 1 μm cut-point cyclone separator upstream of the TOT instrumentation and nvPMmi
- d) a splitter assembly meeting requirements in paragraph 4.2 d) and f) of Attachment A to this Appendix

Note.— An equivalent procedure is provided in the Environmental Technical Manual (Doc 9501), Volume II – Procedures for the Emissions Certification of Aircraft Engines.

- e) stainless steel or anti-static tubing to connect the manual quartz filter sampler, or a semi-continuous EC/OC analyser, and the nvPMmi. All tubing shall be of the same material, length, and temperature from the split point to the instrument inlets
- f) **Recommendation.—** *If anti-static tubing is used, the tubing should meet the anti-static specification in ISO 8031.*

3.1.2 Depending on the instrument used for the TOT measurement, the following requirements shall be met:

- a) if manual sampling and laboratory analyser are used, one pre-fired, quartz filter in a stainless steel filter holder having a tapered inlet section with a $\leq 12.5^\circ$ half-angle operated at a filter face velocity less than or equal to 0.5 m/s at actual operating conditions shall be used. The diameter of the filter deposit shall be large enough to allow at least one punch to be collected from each filter. At least one punch shall be analysed from each quartz filter sample collected; or
- b) if a semi-continuous TOT analyser is used it shall be operated at a filter face velocity of less than or equal to 0.5 m/s

3.1.3 Measurements shall be made at tiered levels of target EC mass concentration specified in Table A7-5. Achieved EC mass concentrations shall be within 20 per cent of the target mass concentrations specified.

3.1.4 At each concentration tier level, samples shall be taken for a similar time period to establish a repeatable EC filter loading. The EC filter loading shall be $12 \pm 5 \mu\text{g}/\text{cm}^2$.

3.1.5 The averaging time as defined in ISO 9169 shall be the same as the filter collection time.

3.1.6 The average EC content determined by the TOT method shall be greater than or equal to 80 per cent of total carbon.

- 3.1.7 EC mass concentrations from the TOT method and the nvPMmi mass concentrations shall be used to determine parameters as specified in paragraph 4 to this Attachment that demonstrate conformity to the performance specifications in Table A7-3.

Table A7-5. EC mass loading parameters for calibration samples.

Target Concentration ($\mu\text{g}/\text{m}^3$)	Approval Certificate No. of Tests	Annual Calibration No. of Tests
0 (blank run)	6	3
50	6	0
100	6	3
250	0	3
500	6	3

- 3.1.8 *Recommendation.* – 3 points at 50 $\mu\text{g}/\text{m}^3$ for annual calibration should be tested.

3.2 Measurement using a gas turbine engine exhaust nvPM source

3.2.1 Paragraphs 3.1.4 to 3.1.5 shall be repeated for a gas turbine engine exhaust nvPM source using the measurement system specified in paragraphs 3.1.1 c), d), e) and 3.1.2 with a dilution system using HEPA filtered diluent.

Note. – Sufficient dilution should be used to prevent water condensation in the sample line.

3.2.2 A minimum of four data points shall be obtained for a minimum of three different thrust levels with duplicate measurements made at one of the thrust levels using the nvPM sampling system specified above. The measurements shall be conducted at a minimum of three target concentrations, each at least a factor of 1.5 apart from the next, at least one concentration shall be above 120 $\mu\text{g}/\text{m}^3$, and at least one concentration shall be below 120 $\mu\text{g}/\text{m}^3$. The EC filter loading for these four data points shall be between 2.5 $\mu\text{g}/\text{cm}^2$ and 17 $\mu\text{g}/\text{cm}^2$.

3.2.3 EC mass concentrations from the TOT method and the nvPMmi mass concentrations shall be used to determine applicability as specified in Table A7-3 to demonstrate conformity to the performance specifications.

3.2.4 The engine test fuel shall be one of the aviation turbine engine fuels listed in ICAO Doc 9977, Chapter 3, Paragraph 3.2. The same fuel shall be used for the minimum four data points.

4. CALCULATION OF INSTRUMENT PERFORMANCE

4.1 The nvPMmi performance parameters zero drift, rise time and sample rate shall be determined as specified in ISO 9169, paragraphs 6.6, 6.3 and 2.1.7 respectively.

4.2 Repeatability parameter of the nvPMmi at 95 per cent confidence interval shall be determined using 6 consecutive measurements at each concentration level as:

$$s_{r_i}^2 = s_{Y_i}^2 - \Delta^2 \cdot s_{C_i}^2$$

where

$$s_{Y_i}^2 = \frac{\sum_{j=1}^n (Y_{i,j} - \bar{Y}_i)^2}{(n - 1)}$$

s_{C_i} the standard deviation over j of the $C_{i,j}$ for level i

$Y_{i,j}$ the result of measurement by the instrument of the reference material $C_{i,j}$

$C_{i,j}$ the jth instance of the reference material concentration at level i

Y_i the average over j of the $Y_{i,j}$

n number of consecutive measurements at each concentration level (6 minimum)

Δ the slope of the regression function applied in the lack of fit test determined from the below equations.

$$E_{i,j} = Y_{i,j} - (\Gamma + \Delta \times C_{i,j})$$

$$E_i = \frac{\sum_{j=1}^n E_{i,j}}{n}$$

where

$E_{i,j}$ the difference between $C_{i,j}$, and $Y_{i,j}$

E_i the average over j of the $E_{i,j}$

Γ the intercept of the regression function applied in the lack of fit test

Note. – If the repeatability so determined is negative, indicating that the variance of the measurement could not be discriminated from the variability of the reference material, the test should be repeated with additional attention given to the stability of the reference material source (diffusion flame nvPM source flow and pressure settings) and the accuracy of the determination of the reference material level (TOT method loadings and procedures). Failing this, the reproducibility can be reported as “significantly better than $\Delta \cdot s_{C_i}^2$.”

4.3 Linearity of the nvPMmi shall be determined as specified in ISO 9169, paragraph 6.4.5.4, however with the residual determined by the following:

$$E_i = \frac{\sum_{j=1}^n E_{i,j}}{n}$$

4.4 Limit of Detection of the nvPMmi shall be determined as specified in ISO 9169, paragraphs 6.4.5.5. If the instrument does not make a measurement when there are no particles in the sample, then a higher nvPM mass concentration, C_{LOD} , just above zero shall be used such that the instrument produces regular readings. The Limit of Detection in this case shall be determined as:

$$Y_{D,0.95} = \bar{Y}_{LOD} - C_{LOD} + 2 \times t_{v,0.95} \times s_{LOD}$$

where

$Y_{LOD,0.95}$ Limit of Detection at 95 per cent confidence interval

\bar{Y}_{LOD} The average of the values $Y_{LOD,j}$

C_{LOD} The average of the values $C_{LOD,j}$

$t_{v,0.95}$ The two sided Student's factor at 95 per cent confidence, degree $v=n-1$

s_{LOD} The standard deviation associated with the average Y_{LOD}

Note.— The reference material may not be the same in consecutive measurements taken over the averaging time. Thus, each determination of the reference material's value may be different, albeit well known as determined by the TOT method. ISO 9169 definitions are modified to accommodate such variability.

5. CALIBRATION

5.1 The nvPMmi shall be calibrated annually using the TOT method and a system setup specified in paragraphs 3.1.1 and 3.1.2 to this Attachment.

5.2 Measurements shall be made at tiered levels of target EC mass concentration specified in Table A7-5. Achieved EC mass concentrations shall be within ± 20 per cent of target mass concentrations specified.

5.3 At each concentration tier level, samples shall be taken for a similar time period to establish a repeatable EC filter loading. The EC filter loading shall be $12 \pm 5 \mu\text{g}/\text{cm}^2$.

5.4 The averaging time as defined in ISO 9169 shall be the same as the filter collection time.

5.5 EC mass concentrations from the TOT method and the nvPMmi mass concentrations shall be used to establish the best fit for the data points collected from the calibration of the instruments. A linear least squares method shall be used to determine the scale factor b to adjust the nvPM mass concentrations reported by the nvPMmi as follows:

$$b = \frac{\sum x_i y_i}{\sum x_i^2}$$

where

x_i i^{th} nvPMmi measurement

y_i i^{th} TOT EC mass concentration

b Slope of the best fit line

Note 1.— Once the b scaling factor is applied, the slope of a linear regression of the EC assays against the instrument readings adjusted by b is mathematically equal to 1.0, and the requirement on the slope in Table A7-3 will be met by definition.

Note 2.— Because of the expected uncertainties in the repeatability of the TOT EC assays a repeat of the above process at the same or at a different laboratory may produce a different slope without any change in the response of the instrument. The accuracy specifications of Table A7-3 are intended to account for such variability.

5.6 **Recommendation.**— *Prior to each annual calibration, the performance of each mass instrument should be assessed in the “as found” condition at an EC mass concentration of 100 $\mu\text{g}/\text{m}^3$ listed in Table A7-5. This assessment will allow traceability to prior calibrations of the instrument and allow comparison of existing and new calibration constants.*

ATTACHMENT C TO APPENDIX 7**SPECIFICATIONS AND CALIBRATION FOR THE VOLATILE PARTICLE REMOVER AND THE NVPM NUMBER INSTRUMENT****1. SPECIFICATIONS****1.1 VPR specifications**

Each make and model of the VPR shall receive a certificate from the instrument manufacturer or from another competent testing and calibration laboratory confirming that it meets the performance specifications listed in the following subsections.

1.1.1 The VPR dilution factor (DF_2) shall meet the following requirements:

- a) DF_2 shall be adjusted to maintain particle number concentration within CPC single count mode and to reduce sample temperature to between 10°C and 35°C at the CPC inlet.
- b) DF_2 variability shall be less than 10 per cent.

1.1.2 The heated section which evaporates volatile species shall be maintained at a temperature of 350°C ±15°C

1.1.3 If the VPR contains multiple heated stages, the additional temperature controls shall be ±15°C of operating temperatures specified by the VPR manufacturer.

1.1.4 The sample pressure control shall meet the following requirements:

- a) A pressure control device shall permit to deliver diluted sample to CPC within ±15 kPa of ambient (CPC exhaust) pressure.
- b) The pressure shall not exceed 105 kPa.

1.1.5 The minimum allowed particle penetration fractions of the VPR for each dilution setting shall meet the specifications listed in Table A7-6.

Table A7-6: Minimum allowed penetration fractions of the VPR at four particle diameters

Electrical Mobility Particle Diameter, D_m	15 nm	30 nm	50 nm	100 nm
Minimum Penetration fraction, $\eta_{VPR}(D_m)$	0.30	0.55	0.65	0.70

1.1.6 The VPR volatile removal efficiency (VRE) shall be such that more than 99.5 per cent of tetracontane ($CH_3(CH_2)_{38}CH_3$, greater than 95 per cent purity) particles with an inlet concentration of at least 10,000 particles/cm³ at 30 nm electrical mobility diameter are removed. This VRE shall be demonstrated when the VPR is operated at its minimum dilution setting and manufacturer's recommended operating temperature.

1.1.7 If a catalytic stripper is used in the VPR, the diluent shall contain at least 10 per cent of O₂.

1.2 VPR to CPC Interface

The tube connecting the VPR outlet to the inlet of the CPC shall meet the following requirements:

- a) The material shall be electrically conductive.
- b) The tube shall have an internal diameter greater than or equal to 4 mm.
- c) The sample in the tube shall have a residence time less than or equal to 0.8 seconds.

1.3 CPC specifications

Each make and model of the CPC shall receive a certificate from the instrument manufacturer or from another competent testing and calibration laboratory confirming that it meets the performance specifications listed below.

1.3.1 A coincidence correction function up to a maximum of 10 per cent correction shall be allowed. The coincidence correction function shall not use any algorithm to correct for or define the counting efficiency.

1.3.2 The counting of the particles shall meet the following requirements:

- a) The counting mode shall be a single count mode. CPC use in the photometric mode is not allowed. Thus, to ensure single count mode, DF₂ shall be increased as necessary.
- b) The counting accuracy shall be of ±10 per cent from 2000 particles/cm³ to the upper threshold of the single particle count mode against a traceable standard (ISO 27891).
- c) The counting efficiency shall be greater than or equal to 50 per cent at 10 nm electrical mobility diameter and greater than or equal to 90 per cent at 15 nm electrical mobility diameter.
- d) The counting efficiency shall be established using an Emery oil aerosol.

1.3.3 The data acquisition rate shall be greater than or equal to 1.0 Hz for a minimum interval of 30 seconds once the engine is stabilised.

1.3.4 The particle number concentration shall be reported as particles/cm³ at STP conditions. If the reported value is not at STP conditions, the CPC absolute inlet pressure shall be measured with an accuracy better than 2 per cent so that the number concentration can be corrected to STP conditions, following manufacturer's guidelines.

1.3.5 The resolution shall be better than 0.1 particles/cm³ at concentrations below 100 particles/cm³.

1.3.6 The rise time shall be less than 4 seconds.

1.3.7 The sample flow shall be full flow. No internal flow splitting is allowed.

1.3.8 The working fluid shall be n-butanol.

1.3.9 The response shall be linear.

1.4 System requirement

The t₉₀ from the inlet of the VPR through the CPC shall be equal or less than 10 seconds.

2. CALIBRATION

2.1 VPR

Recommendation.– *Prior to each VPR calibration, the VPR should be validated “as found” at a single DF₂ setting, typical of that used for measurements on aircraft turbine engines. This validation should include the VPR dilution factor at the selected DF₂ setting, the determination of the penetration fractions and volatile removal efficiency.*

2.1.1 The VPR dilution factor (DF₂) calibration shall meet the following requirements:

- a) The DF₂ shall be calibrated at each dilution setting of the VPR, as defined by the VPR manufacturer.
- b) **Recommendation.**– *The DF₂ calibration should be performed by a competent laboratory, using either trace gases such as CO₂, or flow measurements.*

2.1.2 VPR particle penetration fractions calibration shall meet the following requirements:

- a) The VPR particle penetration fractions shall be measured at 350°C with solid particles of 15 nm, 30 nm, 50 nm and 100 nm electrical mobility diameters for each dilution setting of the VPR. A minimum of 5000 particles/cm³ across the four particle sizes shall be delivered to the VPR. If soot is used for particle generation then a thermal pre-treatment device heated to 350°C may be needed to deliver only nvPM to the VPR.
- b) Particle concentrations shall be measured upstream and downstream of the VPR with a CPC that has at least 90 per cent counting efficiency for particles of an electrical mobility diameter greater than or equal to 15 nm.
- c) The VPR penetration fractions shall be determined as follows:

$$\eta_{\text{VPR}}(D_m) = \frac{DF_2 \times N_{\text{out}}(D_m)}{N_{\text{in}}(D_m)}$$

where

$N_{\text{in}}(D_m)$ upstream particle number concentration for particles of D_m

$N_{\text{out}}(D_m)$ downstream particle number concentration for particles of D_m

- d) $N_{\text{in}}(D_m)$ and $N_{\text{out}}(D_m)$ shall be referenced to the same T and P conditions.
- e) **Recommendation.**– *The VPR should be calibrated as a complete unit.*

2.1.3 VPR Volatile Removal Efficiency (VRE)

- a) The VRE shall be determined with a CPC that has at least 90 per cent counting efficiency for particles of an electrical mobility diameter greater than or equal to 15 nm, as follows:

$$VRE(D_{30}) = 100 \times \left[1 - \frac{DF_2 \times N_{out}(D_{30})}{N_{in}(D_{30})} \right]$$

where

$VRE(D_{30})$ VRE for particles of D_{30}

$N_{in}(D_{30})$ upstream particle number concentration for particles of D_{30}

$N_{out}(D_{30})$ downstream particle number concentration for particles of D_{30}

D_{30} particle electrical mobility diameter

b) $N_{in}(D_{30})$ and $N_{out}(D_{30})$ shall be referenced to the same T and P conditions.

2.2 CPC calibration

2.2.1 The CPC calibration shall be traceable to a standard calibration method (ISO 27891): by comparison the response of the CPC under calibration with that of a calibrated aerosol electrometer when simultaneously sampling electrostatically classified calibration particles.

2.2.2 **Recommendation.** – *Prior to each CPC calibration, the CPC should be validated (“as found”).*

2.2.3 The calibration and validation shall be performed using the procedures described below:

- a) The CPC’s detection efficiency shall be calibrated with particles of 10 and 15 nm electrical mobility diameter. The CPC shall have a counting efficiency of greater than or equal to 50 per cent at 10 nm and greater than or equal to 90 per cent at 15 nm.
- b) The calibration aerosol shall be Emery oil.

ATTACHMENT D TO APPENDIX 7.
SPECIFICATIONS FOR ADDITIONAL DATA

As required in 3.2 of Appendix 7, the data in Tables A7-7 and A7-8 shall be provided.

Table A7-7. Ambient nvPM Requirements

Data Required	Units
Ambient nvPM mass concentration ($nvPM_{mass_STP}$)	$\mu g/m^3$
Ambient nvPM number concentration ($DF_2 \times$ $nvPM_{num_STP}$)	particles/cm ³

Table A7-8. nvPM Sampling System and Measurement Parameter Requirements

Parameter	Unit
Probe inlet temperature (T_{engine_exit}) (Equivalent to performance-predicted engine exit exhaust gas temperature T_{EGT})	°C
Measured Diluter1 inlet temperature (T_1)	°C
Individual flow rates (Measured Section 3 & Section 4; Practical estimation Section 1, Section 2)	slpm
Individual pipe inner diameters for Sections 1 to 4	mm
Individual lengths for Sections 1 to 4	m
Individual pipe wall temperatures for Sections 1 to 4	°C
Section 1 total angle of sampling tube bend(s)	degrees
Cyclone separator D_{50} cutpoint (Manufacturer Specification)	nm
Cyclone separator sharpness (Manufacturer Specification)	decimal fraction
Diluter1 four penetration values (Attachment A Table A7-2)	decimal fraction
VPR calibration four penetration values (Attachment C Table A7-6)	decimal fraction
CPC calibration two counting efficiencies	decimal fraction
First stage dilution factor, DF_1	
Second stage (VPR) dilution factor, DF_2	
Particle mass concentration corrected for DF_1 : $DF_1 \times nvPM_{massSTP}$	$\mu g/m^3$
Particle number concentration corrected for DF_1 and DF_2 : $DF_1 \times DF_2 \times nvPM_{numSTP}$	Particles/cm ³

ATTACHMENT E TO APPENDIX 7
PROCEDURES FOR SYSTEM OPERATION

1. COLLECTION PART AND GAS LINE LEAKAGE CHECK

1.1 Leakage check procedure

Prior to an engine test series, the Collection Part and the GL shall be checked for leakage using the following procedure:

- a) isolate the GL from the nvPM Measurement Part using the Isolation Valve 1, the P₁ Pressure Control Valve and, if installed, the optional shut-off valve;
- b) isolate the probe and the analysers;
- c) connect and operate a vacuum pump to verify the leakage flow rate.
- d) The vacuum pump shall have a no-flow vacuum capability of -75 kPa with respect to atmospheric pressure; its full-flow rate shall not be less than 28 L/min at normal temperature and pressure.

1.2 Leakage check requirement

The leakage flow rate shall be less than 0.4 slpm.

2. COLLECTION PART AND GAS LINE CLEANLINESS CHECK

2.1 Cleanliness check procedure

The Collection Part and GL shall be checked for cleanliness using the following procedure:

- a) isolate the GL from the nvPM Measurement Part using Isolation Valve 1 and the P₁ Pressure Control Valve;
- b) isolate the GL from the probe and connect that end of the sampling line to a source of zero gas;
- c) Warm the system up to the operational temperature needed to perform hydrocarbon measurements;
- d) Operate the sample flow pump and set the flow rate to that used during engine emission testing;
- e) Record the hydrocarbon analyser reading.

2.2 Cleanliness check requirement

2.2.4 The hydrocarbon reading shall not exceed 1 per cent of the engine idle emission level or 1 ppm (both expressed as carbon), whichever is the greater.

2.2.5 **Recommendation.**— *It is recommended to monitor the inlet air quality at the start and end of an engine test and at least once per hour during a test. If HC levels are considered significant, then they should be taken into account.*

3. TRANSFER PART CLEANLINESS/LEAKAGE CHECK

Cleanliness checks can fail due to contaminated Transfer Part components or leaks in the Transfer and/or Measurement Parts.

Note.— *A system leakage will result in ambient air particles drawn into the system.*

3.1 Cleanliness/leakage check procedure

Prior to an engine test series, the Transfer Part shall be checked for cleanliness and leaks using the following procedure:

- a) flow filtered diluent through Diluter1 with the Isolation Valve 1 closed;
- b) the flow rates in each Splitter2 path shall be equal to those used during engine testing.
- c) Set the DF₂ to the lowest setting of the VPR.

When the measured nvPM mass and number concentrations are stable, record data for a minimum of 30 seconds.

Note. — *The flow schematic for the Transfer Part cleanliness check is shown in Figure A7-4*

3.2 Cleanliness/leakage check requirement

3.2.1 The 30 seconds averaged nvPM mass concentration (nvPM_{mass_STP}) shall be less than 1 µg/m³.

3.2.2 The 30 seconds averaged nvPM number concentration (nvPM_{num_STP}) shall be less than 2.0 particles/cm³.

3.2.3 **Recommendation.** – *If the cleanliness check fails, the system should be first inspected for leakage. If no leaks are detected, the cyclone separator collection reservoir should be inspected and cleaned. If the cleanliness check still fails, segments of the sampling system may need cleaning or replacement.*

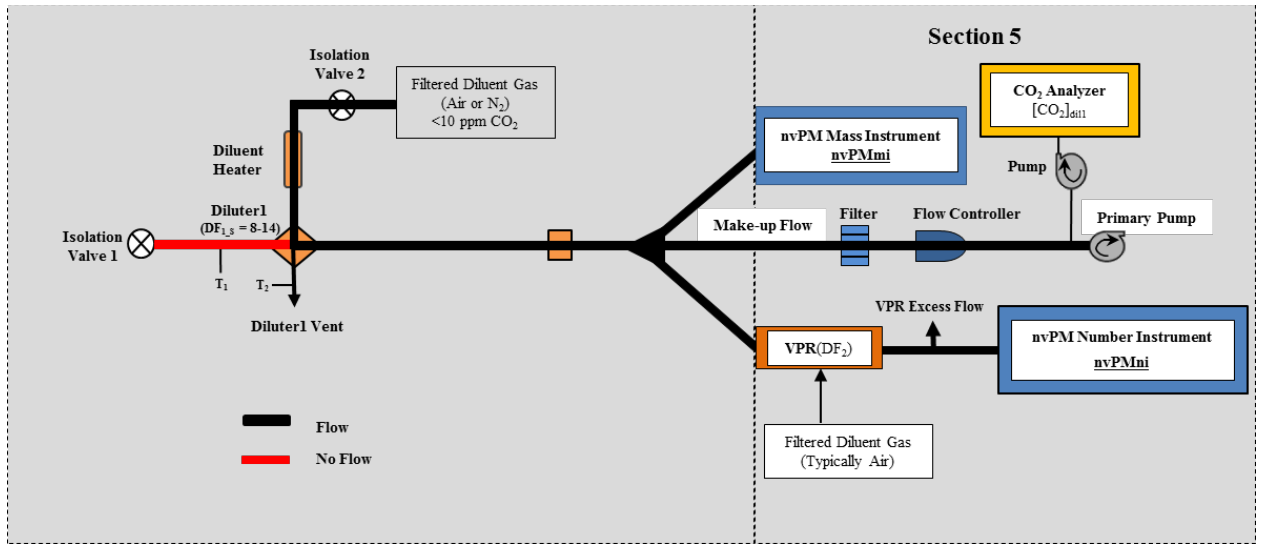

Figure A7-4. Flow schematic for the Transfer Part cleanliness check

4. COLLECTION PART BACK-PURGING

In order to maintain the Section 1 sampling probes and lines clear of unburned fuel, Section 1 shall be back-purged during engine start-up and shutdown as depicted in Figure A7-5.

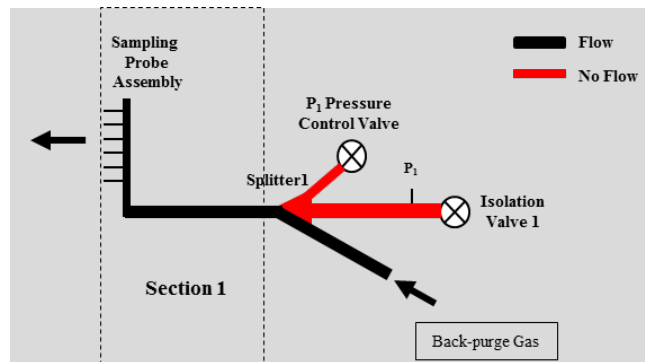

Figure A7-5. Flow schematic for Section 1 back-purge

5. AMBIENT nvPM MEASUREMENT

5.1 General

5.1.1 Ambient nvPM mass and number concentrations representative of engine air inlet shall be obtained before and after an engine test and reported as the average of these two measurements.

5.1.2 **Recommendation.** – *For an enclosed test cell, to achieve representativeness, it is recommended that the ambient particle measurements are obtained while the engine is running. The first ambient measurement should be obtained a minimum of five minutes after engine start-up.*

5.2 Ambient nvPM sampling procedure

The ambient nvPM mass and number concentrations representative of engine air inlet shall be sampled by either:

5.2.1 Method 1 - sampling through Diluter1 vent.

The nvPM Sampling and Measurement system shall be used to sample through Diluter1 vent.

When sampling through the Diluter1 vent the following procedure shall be used:

- a) Turn off the diluent flow supply to Diluter1 by closing Isolation Valve 2 and ensure that the Isolation Valve 1 is closed;
- b) **Recommendation.**– *The diluent heater should be protected from overheating when the diluent flow is turned off*
- c) Ensure flow rates in each Splitter2 flow path are equal to those to be used during engine testing;
- d) When the measured nvPM mass and number concentrations are stable, record data for a minimum of three minutes.

Note.– *The flow schematic for the method 1 ambient nvPM measurement is shown in Figure A7-6.*

This setup shall only be used if the vent exhaust location is representative of engine inlet air.

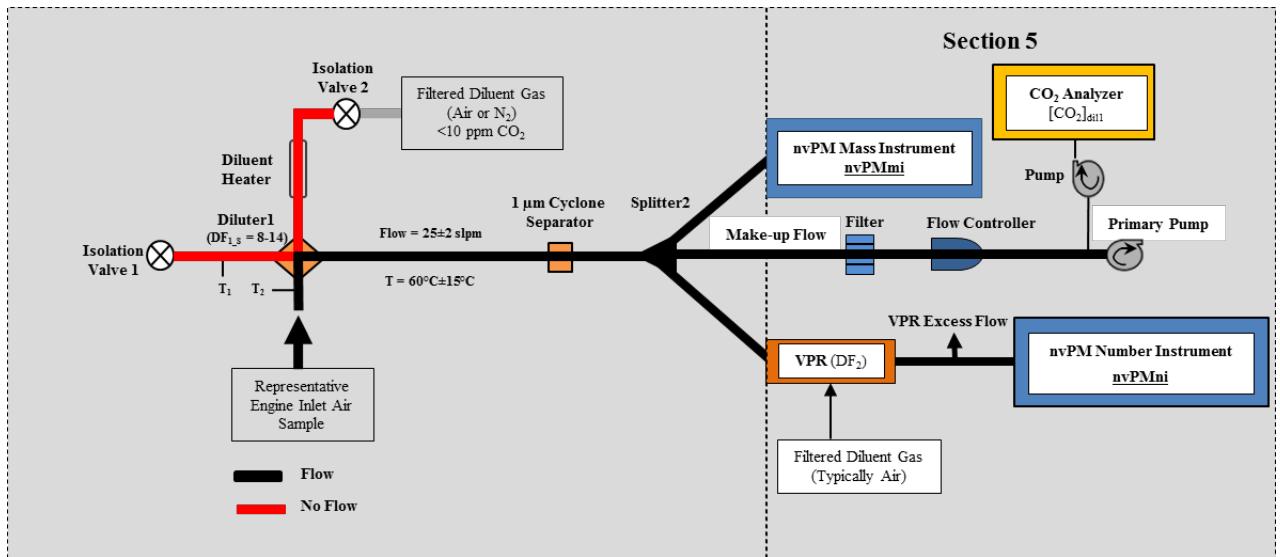

Figure A7-6. Flow schematic for ambient particle air measurement

5.2.2 Method 2 – an additional nvPM measurement system

5.2.2.1 An additional ambient nvPM sampling and measurement system shall meet the following requirements:

- The ambient nvPM sampling system shall conform to Section 3 and Section 4 sampling system requirements in Attachment A to this Appendix.
- The nvPMmi, VPR and nvPMni shall comply with Attachments B and Attachment C to this Appendix.
- The ambient nvPM sampling system inlet shall be located within 50 m of the engine intake plane.

5.2.2.2 When sampling with an additional nvPM sampling and measurement system, the following procedure shall be used:

- Ensure flow rates in each Splitter2 path are equal to those to be used during engine testing.
- When the measured nvPM mass and number concentrations are stable, record data for a minimum of three minutes.

5.3 Ambient particle measurement requirement

5.3.1 The three minutes averaged nvPM mass concentration ($nvPM_{mass_STP}$) and nvPM number concentration corrected for DF_2 ($DF_2 \times nvPM_{num_STP}$) shall be reported.

Note. – The ambient level of nvPM mass concentration may be below the LOD of the nvPMmi.

5.3.2 **Recommendation.** – The average nvPMni concentration value corrected for DF_2 should be greater than 10 times the value measured for the cleanliness check. If this check fails, the system operation should be verified (valve positions, flow rates, pressures and temperatures) and the measurement should be repeated.

5.3.3 **Recommendation.** – *If ambient nvPM levels are considered significant, then they should be taken into account.*

6. VPR DILUTION FACTOR CALIBRATION CHECK

6.1 The VPR dilution factors (DF_2), anticipated during the engine test, shall be checked using the following setup:

- a) a CO₂ gas analyser compliant with attachment B to Appendix 3;
- b) a certified, high concentration CO₂ gas with purity 2.0 (greater than 99.0 per cent) CO₂;

Note.– *Guidance material is provided in the Environmental Technical Manual (Doc9501), Volume II – Procedures for the Emissions Certification of Aircraft Engines.*

- c) connect the CO₂ gas analyser to the outlet of the VPR with a tee fitting to prevent overpressurisation of CO₂ sample;
- d) connect the high concentration CO₂ gas to the inlet of the VPR using a tee fitting and flow control valve to provide a VPR inlet pressure as on engine test;
- e) allow the sample at the inlet of the VPR to have the same flow rate, and pressure as used during an engine test.

Note.– *The flow schematic for the VPR dilution factor check is shown in Figure A7-7.*

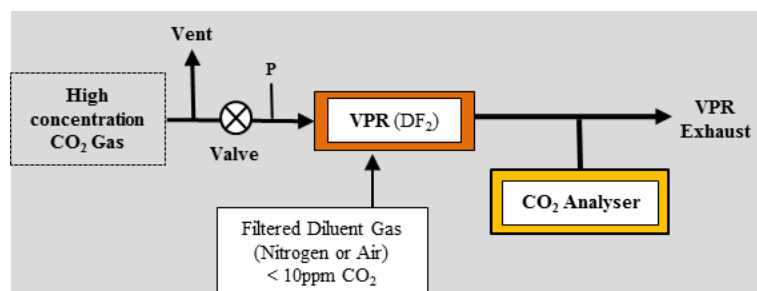

Figure A7-7. VPR Dilution Factor Check Setup

6.2 The VPR dilution factor (DF_2) shall be checked using the following procedure:

- a) warm-up the VPR and ensure operating temperatures are reached;
- b) check that the VPR inlet is pulling a sample flow.
- c) warm-up the CO₂ analyser accordingly and prepare for data logging.
- d) apply appropriate zero calibration gas to the CO₂ analyser and make any necessary instrument adjustments.
- e) apply appropriate calibration gas at a nominal 90 per cent FS concentration to the CO₂ analyser to span the ranges to be used, adjust and record gain settings accordingly.
- f) ensure the sample flow to the CO₂ analyser is adequate (a pump may be required upstream of the CO₂ analyser).
- g) flow the high concentration CO₂ gas to the inlet of the VPR, ensuring that there is excess flow at the vent upstream of the VPR inlet.

- h) set the VPR to a dilution factor setting.
- i) adjust the flow control valve at the VPR inlet, creating a pressure drop to simulate the sub-ambient sample pressure at the VPR inlet during an engine test nvPMni measurement operation.
- j) sample the VPR exhaust flow with the CO₂ gas analyser.
- k) when the CO₂ gas analyser reading is stable, record a minimum of seven CO₂ concentration data points within a 3 minute period and calculate the mean.
- l) Calculate the mean DF₂ value as a ratio of the mean of CO₂ measurements and the certified CO₂ gas concentration.
- m) repeat paragraph 6.2, h) to 6.2, l) to this attachment for each VPR dilution setting to be used during engine testing.

6.3 Calculated DF₂ mean values shall be compared against the results of a Competent Laboratory calibration. If the difference is:

- a) less than or equal to ±10 per cent, DF₂ values from a Competent Laboratory calibration shall be used.
- b) greater than ±10 per cent, the VPR DF₂ values shall be re-determined from calibration by a Competent Laboratory.

Note.– Guidance material on the use of an equivalent procedure is provided in the Environmental Technical Manual (Doc 9501), Volume II – Procedures for the Emissions Certification of Aircraft Engines.

...

**PART IV. NON-VOLATILE PARTICULATE MATTER ASSESSMENT FOR INVENTORY
AND MODELLING PURPOSES**

Note 1.– The purpose of Part IV is to provide recommendations on how to calculate the nvPM mass and number correction factors for the nvPM system losses other than the Collection Part thermophoretic losses. The nvPM system, the Collection Part and the thermophoretic losses calculation are described in Appendix 7.

Note 2.– The nvPM mass and number system loss correction factors permit an estimation of the concentration of the nvPM mass and number at the exhaust of the aircraft engine from the nvPM mass and number concentration obtained following the procedures described in Appendix 7.

Recommendation 1.– *For inventory and modelling purposes, the aircraft turbine engine manufacturers should determine the nvPM mass and nvPM number system loss correction factors (k_{SL_mass} and k_{SL_num}) using the methodology described in Appendix 8 and should report these factors to the appropriate authority.*

Recommendation 2.– *For inventory and modelling purposes, the nvPM mass and number concentration obtained following the procedures described in Appendix 7 should be corrected for system losses using the methodology described in Appendix 8.*

APPENDIX 8. PROCEDURES FOR ESTIMATING nvPM SYSTEM LOSS CORRECTIONS

Note 1.– The procedures specified in this Appendix are concerned with the determination of nvPM sampling and measurement system loss correction factors, excluding the Collection Part thermophoretic loss which is included in Appendix 7 data reporting.

Note 2.– Implementation of the nvPM sampling and measurement system requires a long sample line of up to 35m and includes several sampling and measurement system components, which can result in significant particle loss on the order of 50% for nvPM mass and 90% for nvPM number. The particle losses are size dependent and hence are dependent on engine operating condition, combustor technology and possibly other factors. The procedures specified in this Appendix allow for an estimation of the particle losses.

Note 3.– The system loss correction factors are estimated based on the following assumptions: engine exhaust exit plane nvPM have a lognormal distribution, a constant value of nvPM effective density, a fixed value of geometric standard deviation, limiting the nvPM mass concentration to limit of detection, a minimum particle size cut-off of 0.01 μ m and no coagulation.

Note 4.– The method proposed in this Appendix uses data and measurements as specified in Appendix 7 and Attachments to Appendix 7. Symbols and definitions not defined in this Appendix are defined in Appendix 7 and Attachments.

1. GENERAL

1.1 Within the nvPM sampling and measurement system, particles are lost to the sampling system walls by deposition mechanisms. These losses are both size dependent and independent. The size independent Collection Part thermophoretic loss is specified in Appendix 7 paragraph 6.2.1.

1.2 The overall nvPM sampling and measurement system particle loss excluding the Collection Part thermophoretic loss is referred to as system loss.

1.3 The nvPM size distribution needs to be taken into consideration because the loss mechanisms are particle size dependent. These particle size dependent losses are quantified in terms of the fraction of particles of a given size that penetrate through the sampling system.

2. DEFINITIONS, ACRONYMS, AND SYMBOLS

2.1 Definitions

Where the following expressions are used in this appendix, they have the meanings ascribed to them below:

Aerodynamic diameter of a particle. The diameter of an equivalent sphere of unit density with the same terminal settling velocity as the particle in question, also referred to as “classical aerodynamic diameter”.

Competent laboratory. A testing and calibration laboratory which establishes, implements and maintains a quality system appropriate to the scope of its activities, in compliance with the International Organization for Standardization standard ISO/IEC 17025:2005, as amended from time to time, or equivalent standard and for which the programme for calibration of equipment is designed and operated so as to ensure that calibrations and measurements made by the laboratory are traceable to the International System of Units (SI). Formal accreditation of the laboratory to ISO/IEC 17025:2005 is not required.

Cyclone separator. Separation of particles larger than a prescribed aerodynamic diameter via rotational and gravitational means. The specified cut-point aerodynamic diameter is associated to the percent of particles that penetrate through the cyclone separator.

Electrical mobility diameter of a particle. The diameter of a sphere that moves with exactly the same mobility in an electrical field as the particle in question.

Non-Volatile Particulate Matter (nvPM). Emitted particles that exist at gas turbine engine exhaust nozzle exit plane that do not volatilise when heated to a temperature of 350°C.

Particle loss. The loss of particles during transport through a sampling system. This loss is due to various deposition mechanisms, some of which are size dependent.

Particle mass concentration. The mass of particles per unit volume of sample.

Particle mass emission index. The mass of particles emitted per unit of fuel mass used.

Particle number concentration. The number of particles per unit volume of sample.

Particle number emission index. The number of particles emitted per unit of fuel mass used.

Particle size distribution. List of values or a mathematical function that represents particle number concentration according to size.

Penetration fraction. The ratio of particle concentration downstream and upstream of a sampling system element.

2.2 Acronyms

CPC Condensation Particle Counter

nvPMmi Non-volatile particulate matter mass instrument

nvPMni Non-volatile particulate matter number instrument

nvPM Non-volatile particulate matter (see definition)

slpm Standard litres per minute (Litres per minute at STP)

STP Instrument condition at standard temperature 0°C and pressure 101.325 kPa

VPR Volatile Particle Remover

2.3 Symbols

C_c $1 + \frac{2\lambda}{D_m} \times (1.165 + 0.483 \times e^{-\frac{0.997D_m}{2\lambda}})$, the dimensionless Cunningham slip correction factor

DF1 first stage dilution factor

DF2 second stage (VPR) dilution factor as per calibration

D $\frac{k_B \times (273.15 + T_i) \times C_c}{3 \times \pi \times \mu \times D_m \times 10^{-4}}$, the particle diffusion coefficient, cm²/s

D_m nvPM electric mobility diameter, μm

D_{mg} geometric mean diameter, μm

δ the sum of the square of relative differences between measured and calculated dilution corrected mass and number concentrations

EI_{mass} nvPM mass emission index corrected for thermophoretic losses, in mg/kg fuel

EI_{num} nvPM number emission index corrected for thermophoretic losses, in number/kg fuel

ϵ convergence criterion (1×10^{-9})

$f_{ign}(D_m)$ the lognormal distribution function with parameters of geometric standard deviation, σ_g , and geometric mean diameter, D_{mg} ,

$f_N(D_m)$ the engine exhaust nozzle exit plane particle number lognormal distribution function

ID_{ti} Inner diameter of the i^{th} segment of the sampling line, mm

k_B 1.3806×10^{-16} (g·cm²)/(s²·K)

$k_{SL_{mass}}$ EI_{mass} correction factor for system losses without Collection Part thermophoretic loss correction, μg/m³

$k_{SL_{num}}$ EI_{num} correction factor for system losses without Collection Part thermophoretic loss correction, number/cm³

k_{thermo} Collection Part thermophoretic loss correction factor, specified in Appendix 7, paragraph 6.2.1

λ $67.3 \times 10^{-3} \times \left(\frac{273.15 + T_i}{296.15}\right) \times \left(\frac{101.325}{P_i}\right) \times \left(\frac{406.55}{T_i + 383.55}\right)$, the carrier gas mean free path, μm

$nvPM_{mass_EST}$ estimated undiluted (i.e., corrected for dilution) instrument mass concentration, μg/m³

$nvPM_{num_EST}$ estimated undiluted (i.e., corrected for dilution) instrument number concentration, number/cm³

$nvPM_{mass_EP}$	Estimated engine exhaust nozzle exit plane nvPM mass concentration, specified in Paragraph 4 to this Appendix, not corrected for Collection Part thermophoretic losses.
$nvPM_{num_EP}$	Estimated engine exhaust nozzle exit plane nvPM number concentration, specified in Paragraph 4 to this Appendix, not corrected for Collection Part thermophoretic losses.
$nvPM_{mass_STP}$	diluted nvPM mass concentration at instrument STP condition, $\mu\text{g}/\text{m}^3$
$nvPM_{num_STP}$	diluted nvPM number concentration at instrument STP condition, number/ cm^3
$\eta_{mass}(D_m)$	the overall sampling and measurement system penetration fraction for the nvPMmi without Collection Part thermophoretic losses at electrical mobility particle size D_m
$\eta_{num}(D_m)$	the overall sampling and measurement system penetration fraction for the nvPMni without Collection Part thermophoretic losses at electrical mobility particle size D_m
$\eta_i(D_m)$	Penetration fraction for the i th component of the sampling and measurement system
$\eta_{bi}(D_m)$	Penetration fraction for the sampling line bend for i th component of the sampling and measurement system
ρ	the assumed nvPM effective density, g/cm^3
σ_g	the assumed geometric standard deviation of lognormal distribution
Q_i	the carrier gas flow in the i^{th} segment of the sampling line, slpm
Re	$\frac{2 \times \rho_{gas} \times Q_i}{3 \times \pi \times \mu \times ID_{ti}}$, the carrier gas Reynolds number
T_i	the carrier gas temperature in the i^{th} segment of the sampling line, $^{\circ}\text{C}$,

3. CORRECTION FACTORS FOR NVPM MASS AND NUMBER EIS

The EI_{mass} correction factor for system losses is the ratio between estimated engine exhaust nozzle exit plane mass concentration without Collection Part thermophoretic loss correction and measured mass concentration and should be calculated as follows:

$$k_{SL_mass} = \frac{nvPM_{mass_EP}}{DF_1 \times nvPM_{mass_STP}}$$

The EI_{num} correction factor for system losses is the ratio between estimated engine exhaust nozzle exit plane number concentration without Collection Part thermophoretic loss correction and measured number concentration and should be calculated as follows:

$$k_{SL_num} = \frac{nvPM_{num_EP}}{DF_1 \times DF_2 \times nvPM_{num_STP}}$$

4. PROCEDURE TO ESTIMATE ENGINE EXHAUST NOZZLE EXIT PLANE MASS AND NUMBER CONCENTRATIONS CORRECTED FOR SYSTEM LOSSES

The engine exhaust nozzle exit plane mass ($nvPM_{mass_EP}$) and number ($nvPM_{num_EP}$) should be determined using the following procedure:

- For a measured $nvPM_{num_STP}$, begin with an initial value of $nvPM_{num_EP} = 3 \times DF_1 \times DF_2 \times nvPM_{num_STP}$.
- An initial value of $0.02\mu m$ should be assumed for the geometric mean diameter, D_{mg} , of the log normal particle size distribution.
- Starting with initial assumed values of $nvPM_{num_EP}$ and D_{mg} from a) and b) estimate the $nvPM$ mass ($nvPM_{mass_EST}$) and number ($nvPM_{num_EST}$) concentrations using the following equations:

$$nvPM_{mass_EST} = \sum_{D_m=0.01\mu m}^{1\mu m} \eta_{mass}(D_m) \times \frac{\rho \pi D_m^3}{6} \times nvPM_{num_EP} \times f_{lgn}(D_m) \times \Delta \ln(D_m)$$

$$nvPM_{num_EST} = \sum_{D_m=0.01\mu m}^{1\mu m} \eta_{num}(D_m) \times nvPM_{num_EP} \times f_{lgn}(D_m) \times \Delta \ln(D_m)$$

where

$$f_{lgn}(D_m) = \frac{1}{\sqrt{2\pi} \ln(\sigma_g)} \times e^{-\frac{1}{2} \left(\frac{\ln(D_m) - \ln(D_{mg})}{\ln(\sigma_g)} \right)^2}$$

$\Delta \ln(D_m) = \frac{1}{n} \times \frac{1}{\log_{10}(e)}$, is the width of a size bin in base natural logarithm; e is the Euler's number, and n is the number of particle size bins per decade

- Determine the difference, δ , between $nvPM_{num_STP}$, $nvPM_{mass_STP}$ and the estimates of the $nvPM$ number concentration ($nvPM_{num_EST}$) and the $nvPM$ mass concentration ($nvPM_{mass_EST}$) from the initial engine exhaust nozzle exit plane values using the equation:

$$\delta = \left(\frac{DF_1 \times DF_2 \times nvPM_{num_STP} - nvPM_{num_EST}}{DF_1 \times DF_2 \times nvPM_{num_STP}} \right)^2 + \left(\frac{DF_1 \times nvPM_{mass_STP} - nvPM_{mass_EST}}{DF_1 \times nvPM_{mass_STP}} \right)^2$$

- Repeat steps c) through d) varying $nvPM_{num_EP}$ and D_{mg} until δ reduces to less than 1×10^{-9} .
- Once δ is reduced to less than 1×10^{-9} , the final values of $nvPM_{num_EP}$ and D_{mg} are those associated with this minimised value of δ .
- Using $nvPM_{num_EP}$ and D_{mg} from step f), $nvPM_{mass_EP}$ should be determined using the following expression:

$$nvPM_{mass_EP} = \sum_{D_m=0.01\mu m}^{1\mu m} \frac{\rho \pi D_m^3}{6} \times nvPM_{num_EP} \times f_{lgn}(D_m) \times \Delta \ln(D_m)$$

- h) **Recommendation.**– A total of 80 discrete sizes in the particle size range from 0.003 μm to 1 μm should be used in this calculation. In this case the number of size bins per decade, n, is 32 (see the definition for Δln(Dm) above). The sums in the above equations start at 0.01 μm.
- i) **Recommendation.**– The nvPM effective density should be a constant and equal to 1 g/cm³ across all particle sizes
- j) **Recommendation.** – The geometric standard deviation of the lognormal particle number distribution should be equal to 1.8.

Note 1. – The flow chart shown in figure A8-1 describes this procedure pictorially.

Note 2. – If nvPM_{mass_STP} is less than 1 μg/m³, a minimum value of 1 μg/m³ should be used for the procedure to converge.

Note 3.– The procedure outlined in paragraph 3 is solvable using commercially available software programs.

Note 4.– The units for D_m are in μm which is different from tabulated values given in Appendix 7.

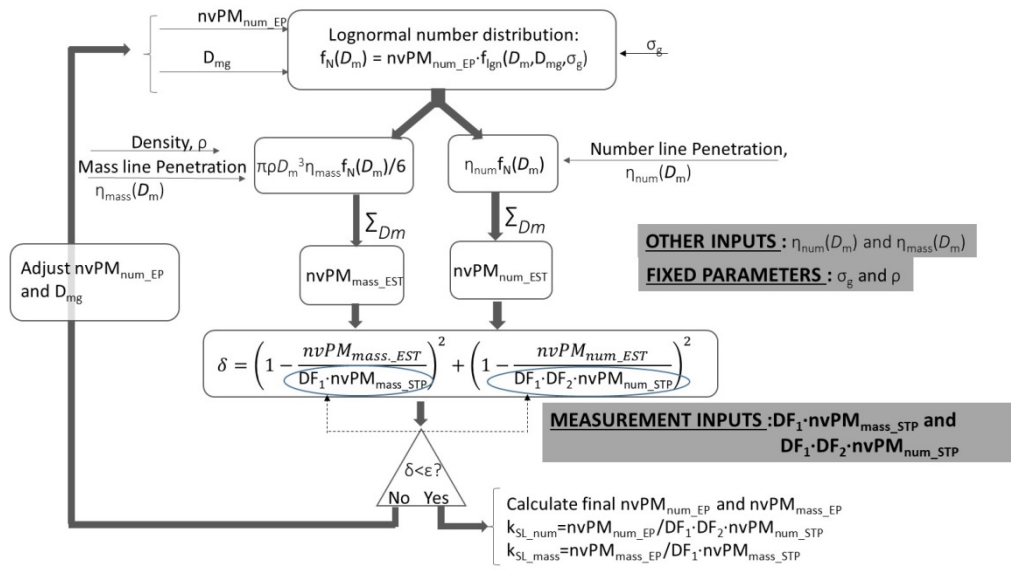

Figure A8-1. Iterative method for calculation of nvPM mass and number corrected for losses other than Collection Part thermophoresis

5. OVERALL SYSTEM PENETRATION FRACTIONS

Note 1.– The particle penetration fractions are different between the nvPM mass concentration measurement and nvPM number concentration measurement because of the difference in sample flow paths after Splitter2.

Note 2.– Penetration fractions may change between different engine condition measurement points because of changing particle size distribution.

Note 3.– Where continuous functions are calculated to estimate penetration fractions or CPC counting efficiency, care should be taken such that they do not go below zero.

Table A8-1. Required nvPM Sampling and Measurement system component penetration fractions

Parameter symbol	Description
$\eta_1(D_m)$	Section 1 – Probe inlet to Splitter1
$\eta_{b1}(D_m)$	Section 1 - Probe inlet to Splitter1 for bends
$\eta_2(D_m)$	Section 2 – Splitter1 to Diluter1 inlet
$\eta_{b2}(D_m)$	Section 2 – Splitter1 to Diluter1 inlet for sampling line bends
$\eta_{dil}(D_m)$	Section 2 – Diluter1
$\eta_3(D_m)$	Section 3 – Diluter1 outlet to Cyclone Separator inlet
$\eta_{b3}(D_m)$	Section 3 – Diluter1 outlet to Cyclone Separator inlet for sampling line bends
$\eta_{cyc}(D_m)$	Cyclone Separator
$\eta_4(D_m)$	Section 4 - Cyclone Separator outlet to Splitter2
$\eta_{b4}(D_m)$	Section 4 - Cyclone Separator outlet to Splitter2 for sampling line bends
$\eta_5(D_m)$	Section 4 – Splitter2 to nvPMmi
$\eta_{b5}(D_m)$	Section 4 – Splitter2 to nvPMmi for sampling line bends
η_{th_m}	Section 5 – Due to thermophoretic loss at the nvPMmi inlet
$\eta_6(D_m)$	Section 4 – Splitter2 to VPR
$\eta_{b6}(D_m)$	Section 4 – Splitter2 to VPR for sampling line bends
$\eta_{VPR}(D_m)$	Section 5 – VPR
$\eta_{CPC}(D_m)$	Section 5 – nvPMni (CPC) counting efficiency
η_{th_n}	Section 5 – Due to thermophoretic loss at the nvPMni inlet

5.1 System Penetration Fraction for nvPM mass

The overall penetration fraction for the nvPM mass, for 80 discrete particle sizes (D_m) in the range from 0.003 μm to 1 μm , should be calculated by combining system component penetration fractions:

$$\eta_{mass}(D_m) = \eta_1 \times \eta_{b1} \times \eta_2 \times \eta_{b2} \times \eta_3 \times \eta_{b3} \times \eta_{cyc} \times \eta_4 \times \eta_{b4} \times \eta_5 \times \eta_{b5} \times \eta_{th_m}$$

Where η with subscripts refer to penetration fractions of individual components of the nvPM sampling and measurement system defined in Table A8-1. Procedures to estimate the individual component penetration fractions are defined in Paragraph 6 to this Appendix.

Note.— Depending on the precise geometry of the nvPM sampling system, there can be more individually described components of the nvPM sampling and measurement system than described in Table A8-1.

5.2 System Penetration Fraction for nvPM number

The overall penetration fraction for the nvPM number, for 80 discrete particle sizes (D_m) in the range from 0.003 μm to 1 μm , should be calculated by combining system component penetration fractions:

$$\eta_{num}(D_m) = \eta_1 \times \eta_{b1} \times \eta_2 \times \eta_{b2} \times \eta_3 \times \eta_{b3} \times \eta_{cyc} \times \eta_4 \times \eta_{b4} \times \eta_6 \times \eta_{b6} \times \eta_{VPR} \times \eta_{CPC} \times \eta_{th_n}$$

where η with subscripts refer to penetration fractions of individual components of the nvPM sampling and measurement system defined in Table A8-1. Procedures to estimate the individual component penetration fractions are defined in Paragraph 6 to this Appendix.

Note.— Depending on the precise geometry of the nvPM sampling system, there can be more individually described components of the nvPM sampling and measurement system than described in Table A8-1.

6. PROCEDURE TO DETERMINE PENETRATION FRACTIONS OF INDIVIDUAL COMPONENTS OF NVPM SAMPLING AND MEASUREMENT SYSTEM

6.1 Data Required

To calculate transport efficiency for particles over a range of sizes, the characteristics of the flow, the transport line and ambient conditions are required. These parameters defined for each line section are listed in Table A8-2.

Table A8-2. Input Parameters

Parameter symbol	Description	Units
T_i	Temperature of the carrier gas at the entrance of i^{th} segment of the sampling line, except for the Collection Part. Assumed to be equal to the temperature of the wall of each section of the transport line and constant throughout the i^{th} segment of the sampling line	$^{\circ}\text{C}$
P_i	Pressure of the carrier gas in the i^{th} segment of the sampling line, assumed constant throughout the i^{th} section and equal to 101.325 kPa	kPa
Q_i	Flow rate of the carrier gas through the i^{th} segment of the sampling line	slpm
ID_i	Inside diameter of the i^{th} segment of the sampling line	mm

L_i	Length of of the i^{th} segment of the sampling line	m
θ_{bi}	Total angle of bends in the i^{th} segment of the sampling line	degrees
$\eta_{\text{VPR}}(15)$, $\eta_{\text{VPR}}(30)$, $\eta_{\text{VPR}}(50)$, $\eta_{\text{VPR}}(100)$	VPR penetration fractions at four particle diameters	dimensionless
$\eta_{\text{CPC}}(10)$, $\eta_{\text{CPC}}(15)$	CPC counting efficiency at two particle diameters	dimensionless

6.2 Diffusional Penetration Fractions

Diffusion of particles onto the surface of the sampling system tube walls results in loss of particles entering a segment of the sampling line or a component. Penetration fractions, $\eta_i(D_m)$, for diffusional losses in sections up to the instrument inlets,

$\eta_i(D_m)$, $i=1, 2, 3, 4, 5$, and 6

are calculated using the expression:

$$\eta_i(D_m) = e^{\frac{-0.6 \times \pi \times ID_{ti} \times L_i \times V_{diff}}{Q_i}}$$

where

L_i length of the i^{th} segment of the sampling line, m

V_{diff} $1.18 \times Re^{0.875} \times Sc^{0.333} \times \frac{D}{ID_{ti}}$, the deposition speed, cm/s

Sc $\frac{\mu}{\rho_{gas} D} \times 10^3$, the carrier gas Schmidt number

m_{gas} 29.0 kg/mol, the molecular mass of the carrier gas

P_i the carrier gas pressure, kPa (assumed to be 101.325 kPa),

Penetration fractions at 80 discrete particle sizes (D_m) in the range from 0.003 μm to 1 μm should be calculated for diffusional losses for each applicable line section.

6.3 Thermophoresis

A constant instrument inlet thermophoretic penetration, $\eta_{th_m}(D_m) = 1$ should be used for nvPMmi and $\eta_{th_n}(D_m) = 1$ should be used for nvPMni for all particle sizes.

6.4 Particle Loss in Bends

The penetration fraction due to losses in bends

$\eta_{bi}(D_m)$, $i=1, 2, 3, 4, 5$, and 6

is distinguished for turbulent flow, Re greater than 5000, and laminar flow, Re less than or equal to 5000 where Re is the Reynolds number. For laminar flow when Re less than or equal to 5000 the penetration due to bends in the transport lines should be calculated as

$$\eta_{bi} = 1 - 0.01745 \times Stk \times \theta_{bi}$$

For turbulent flow when Re greater than 5000 the penetration due to bends in the transport lines should be calculated as

$$\eta_{bi} = e^{-0.04927 \times Stk \times \theta_{bi}}$$

where

Stk $\frac{Q_i \times C_c \times \rho \times D_m^2 \times 10^{-3}}{27 \times \pi \times \mu \times ID_i^3}$, the dimensionless Stokes number

θ_{bi} Total angle of bends in the of the i^{th} segment of the sampling line, degrees

Penetration fractions at 80 discrete particle sizes (D_m) in the range from 0.003 μm to 1 μm should be calculated for bend losses as applicable for each section of the sampling and measurement system.

6.5 Cyclone Separator Penetration Function

The penetration function of the cyclone separator should be estimated using the following expression:

$$\eta_{cyc}(D_m) = 1 - \int_{x>0}^{D_m} \frac{e^{-\frac{(\ln x - \mu_{cyc})^2}{2\sigma_{cyc}^2}}}{x\sigma_{cyc}\sqrt{2\pi}} dx$$

where

μ_{cyc} $\ln(D_{50})$, and

σ_{cyc} $\ln(D_{16}/D_{84})^{0.5}$

Penetration fractions at 80 discrete particle sizes (D_m) in the range from 0.003 μm to 1 μm should be calculated from the cyclone penetration function. The cyclone separator in the nvPM sampling and analysis system has the following specifications:

- a) Cut-point: $D_{50} = 1.0 \mu\text{m} \pm 0.1 \mu\text{m}$
- b) Sharpness: $(D_{16}/D_{84})^{0.5}$ less than or equal to 1.25

Note 1.– Modern computer spreadsheet applications have the cumulative lognormal distribution built into the function library that can be used to generate the penetration function of the cyclone separator.

Note 2.– For most gas turbine engine applications D_m will be less than 0.3 μm . In such cases the cyclone penetration function will be effectively equal to 1.0.

6.6 VPR Penetration Function

Note.— A smooth function provided by the calibration laboratory that has goodness of fit results (R^2 greater than 0.95) for the four VPR calibration penetration points (Table A8-3) may be used in place of the function determined from the calculation procedure outlined below.

Particle losses in the VPR are due to both diffusion and thermophoresis. The thermophoretic factor, η_{VPRth} , is a constant. The diffusion factor, η_{VPRdi} , is determined from standard particle losses due to diffusion in a laminar flow. The total VPR penetration function should be estimated using the expression:

$$\eta_{VPR} = \eta_{VPRth} \times \begin{cases} 1 - 5.5 \times \psi^3 + 3.77 \times \psi & \psi < 0.007 \\ 0.819 \times e^{-11.5\psi} + 0.0975 \times e^{-70.1\psi} + 0.0325 \times e^{-179\psi} & \psi > 0.007 \end{cases}$$

where

$\Psi = \frac{6 \times D \times L_{VPR}}{Q_{VPR}}$, the deposition parameter

L_{VPR} the effective length of the VPR, m

Q_{VPR} the carrier gas flow in the VPR, slpm

T_{VPR} the VPR temperature, °C

η_{VPRth} VPR thermophoretic loss

The VPR penetration function (η_{VPR}) should be fitted to the four measured penetration points by varying the VPR effective length (L_{VPR}) and the thermophoretic loss factor (η_{VPRth}). The R^2 value should be greater than 0.95 to ensure a good fit to the measured penetrations.

Penetration fractions at 80 discrete particle sizes (D_m) in the range from 0.003 μm to 1 μm should be calculated from the VPR continuous function.

Table A8-3. Minimum allowed penetration fractions of the VPR at four particle diameters

Electrical Mobility Particle Diameter, D_m	0.015 μm	0.03 μm	0.05 μm	0.1 μm
Minimum Penetration fraction, $\eta_{VPR}(D_m)$	0.30	0.55	0.65	0.70

6.7 Diluter1 Penetration Fraction

A constant diluter1 penetration, $\eta_{dil}(D_m) = 1$ should be used for all particle sizes.

Penetration fractions at 80 discrete particle sizes (D_m) in the range from 0.003 μm to 1 μm should be used for the diluter penetration function.

6.8 CPC Counting Efficiency

A continuous function for the CPC counting efficiency should be determined using the two CPC counting efficiencies specified with a two parameter sigmoid function using the expression:

$$\eta_{CPC} = 1 - e^{-\ln(2) \cdot \left[\frac{D_m - D_0}{D_{50} - D_0} \right]}$$

where

$$D_0 = \frac{\alpha_{10}D_{15} - \alpha_{15}D_{10}}{\alpha_{10} - \alpha_{15}}$$

$$D_{50} = \frac{(\alpha_{15}+1)D_{10} + (\alpha_{10} + 1)D_{15}}{\alpha_{15} - \alpha_{10}}$$

$$\alpha_i = \frac{\ln(1 - \eta_{CPC,i})}{\ln(2)}, i = 0.01 \mu m \text{ or } 0.015 \mu m$$

D_{10} 0.01 μm ,

D_{15} 0.015 μm ,

$\eta_{CPC,10}$ the counting efficiency at 0.01 μm , and

$\eta_{CPC,15}$ the counting efficiency at 0.015 μm .

Penetration fractions at 80 discrete particle sizes (D_m) in the range from 0.003 μm to 1 μm should be calculated from the CPC continuous function.

APPENDIX B
(English only)

**SUMMARY OF THE RELEVANT INFORMATION FROM CAEP/10
EXPLAINING THE PROPOSED AMENDMENTS TO ANNEX 16
VOLUME II RELATED TO NVPM EMISSIONS**

A. RATIONALE FOR THE NEW NVPM STANDARD

1. BACKGROUND

1.1 Reducing civil aviation's impact on health and climate is one of the critical elements towards achieving ICAO's strategic objective of environmental protection and sustainable development of air transport. CAEP members and observers recognise that nvPM emissions from civil aircraft play a role in adverse impacts to health and climate and they committed to developing a nvPM standard for aircraft engines.

1.2 The new CAEP/10 nvPM standard has not undergone a cost-effectiveness analysis and is based on the correlation of the maximum nvPM mass concentration and the current smoke number (SN) standard. In parallel to this standard, Annex 16, Vol. II requires the reporting of the nvPM mass and number emission indices that would feed the cost-effectiveness analyses and will support the development of nvPM mass and number LTO based standards. Thus the CAEP/10 nvPM standard is considered to be the first stage in the development of future nvPM standards which would enable demonstrating reductions in aircraft engine nvPM emissions over time. The new CAEP/10 nvPM standard and the reporting requirements apply to in-production engines with a rated thrust greater than 26.7kN from 01/01/2020.

2. REGULATORY LEVEL DEVELOPMENT

2.1 The maximum nvPM mass concentration shall not exceed the regulatory level obtained from the following formula which results from the correlation of nvPM mass concentration (in $\mu\text{g}/\text{m}^3$) and the smoke number.

$$\text{nvPM mass concentration limit line} = 10^{\{3+2.9 \times Foo^{-0.274}\}}$$

2.2 WG3/PMTG collected and analysed data from a limited number of engine tests that were performed with both nvPM mass and Smoke Number (SN) measurements for engines with a rated thrust greater than 26.7kN. The nvPM mass concentrations and the SN were correlated in a log-linear plot (logarithm of nvPM mass concentration in $\mu\text{g}/\text{m}^3$ versus SN). Only data with a SN greater than 5 were considered since they correspond to realistic rated thrusts (Foo) (SN lower than 5 in the regulatory level equation will result in rated thrust greater than 29132kN). The table below justifies the range of data used in developing the best fit correlation line. The largest allowable SNs for engines greater than 26.7 kN falls at the 26.7 kN cut-off point of 34. The largest engines available today would result in a maximum allowable SN around 15. The data points used in the fit for developing the equation ranged from 5 to 40, which corresponds to a range of thrusts of 14.7 to 29,000 kN of thrust. This fitting range is significantly

wider than the range that is relevant from a regulatory perspective and the data fit is very robust within the (narrower) regulatory range where most of data are.

kN thrust	lbs thrust	Max SN
14.7	3,000	40
26.7	6,000	34
529	119,000	15
681	153,000	14
29132	6,549,000	5

2.3 It is assumed that the data are normally distributed in this log-linear space and that Gaussian statistics apply. Thus, the statistical variation in the data can be used to ensure that a line can be drawn that captures a desired fraction of data point based on these statistics. For instance, for a Gaussian distribution, 95.4% of the data points will fall within two standard deviations of the limit line.

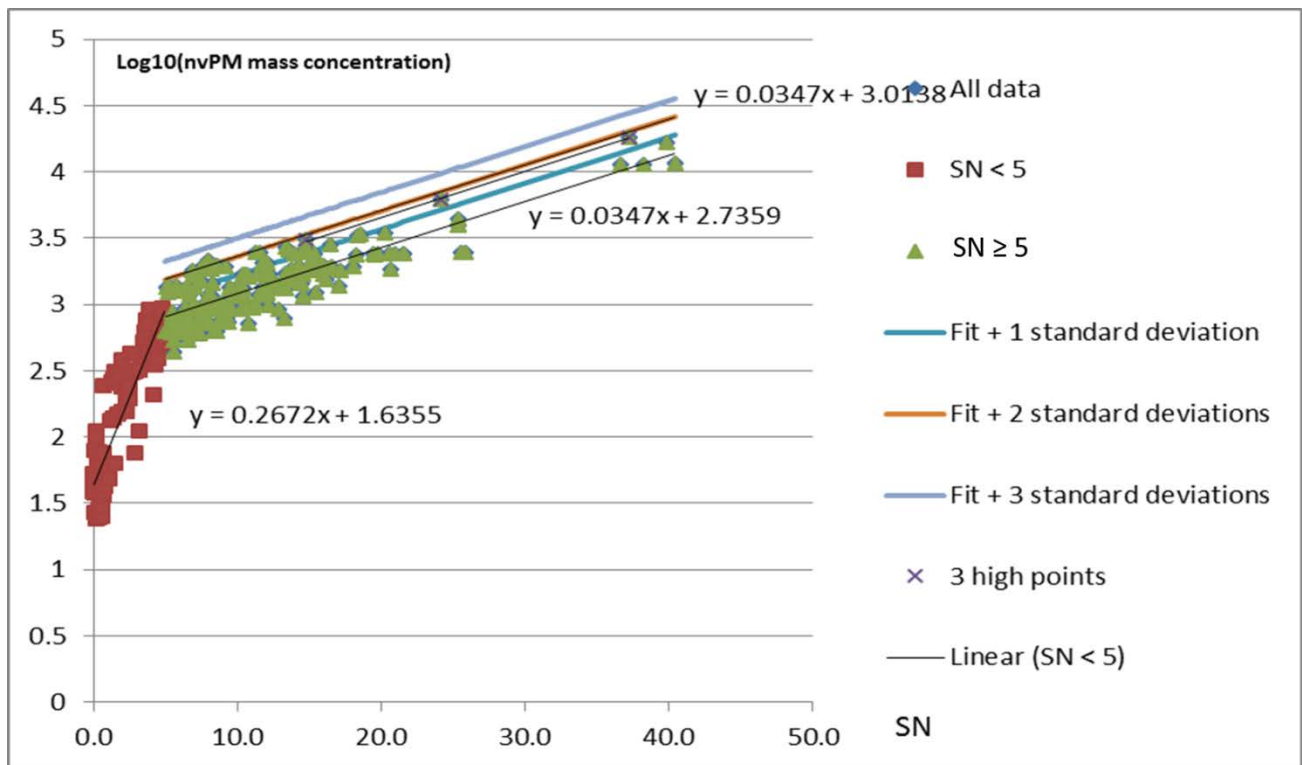

Only the points which are no more than two standard deviations above the line are taken into account. These points can be arbitrarily far below the line. In other words, the distribution is being cut off on the high side, but not the low side. Thus, if we chose the line shifted up by two standard deviations, Gaussian statistics indicates that $(95.4/2 + 100/2) = 97.7\%$ of the points will be captured below this line. The line shifted up by two standard deviations can be expressed as:

$$\text{Log}_{10}(\text{nvPM mass concentration}[\mu\text{g}/\text{m}^3]) = 0.0347 \times \text{SN} + 3.0138$$

2.4 The nvPM mass concentration regulatory level equation is obtained using this expression and substituting the SN from the SN regulatory level $\text{SN} = 83.6 \times \text{Foo}^{-0.274}$.

$$nvPM \text{ mass concentration limit line } [\mu g/m^3] = 10^{\{3.0138 + 2.9009 \times Foo^{-0.274}\}}$$

In order to simplify the final expression for regulatory purposes, two approximations are used.

2.4.1 First, the shift by 2 standard deviations resulted in a term of 3.0138. This is close to 3. If the value of 3 is used instead of 3.0138, then the effective shift of the line is smaller. Instead of two standard deviations, using a “rounded-off” value of 3 would be a shift of 1.9 standard deviations. Thus fewer points would be captured by this line with the smaller shift. However, this is a small change, since Gaussian statistics indicate that this 1.9 standard deviation shifted line would capture 97.15% of the data points (again, only a maximum limit, and no minimum imposed), versus 97.7% for the two standard deviation shifted case.

2.4.2 Second, the coefficient in front of Foo in the resulting expression is 0.0347×83.6 , which equals 2.9009. This is very close to 2.9.

2.4.3 These two numerical values are rounded to the stated values. The other numerical value in the expression is the exponent for Foo itself. The shape of the curve is very sensitive to this exponent, and -0.274 is the exponent used in the regulatory SN limit line. Thus, this Foo exponent numerical value is retained, and the resulting equation for the nvPM mass concentration limit line is given by:

$$nvPM \text{ mass concentration limit line } [\mu g/m^3] = 10^{\{3 + 2.9 \times Foo^{-0.274}\}}$$

2.5 This equation can be presented graphically. Each SN/nvPM data pair is assumed to be potentially a maximum value for a given engine and the associated thrust could be calculated using the SN limit line equation. In reality, most engines are not emitting smoke at the maximum SN, so the actual thrust would be greater (i.e. the SN measured is not at a maximum, thus the corresponding thrust would be greater than using the SN limit line expression). So any point plotted using this SN limit line assumption is a worst case, and other data would have a larger margin to the limit line.

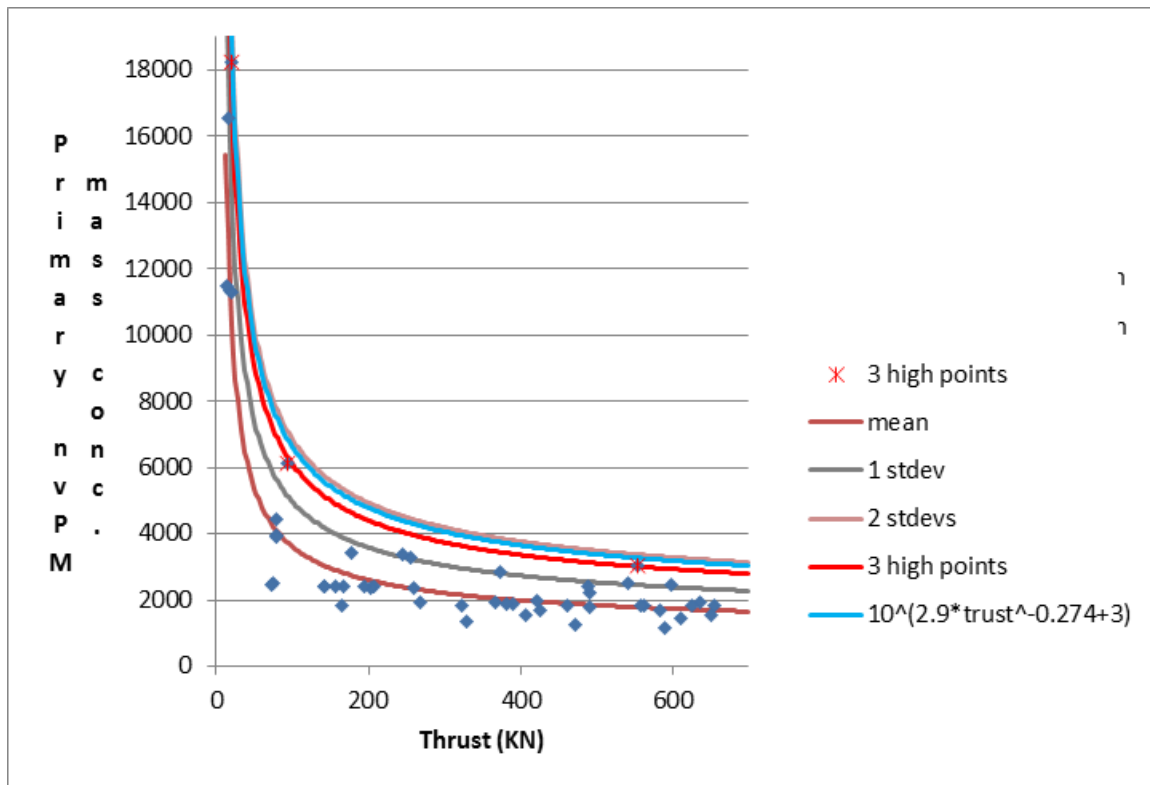

The nvPM data is plotted against thrust, as well as the nvPM regulatory level line. Other curves are plotted: for the best fit line (lowest line), the 1 standard deviation shifted line (second line), the 1.9 standard deviation shifted line (corresponding to the regulatory level, second line from the top), and the 2 standard deviation shifted line (top line). Also plotted is a fit through the three highest points identified in the earlier figure (red curve, middle of the five curves). Clearly, the 1.9 and 2 standard deviation lines are very close to one another and capture all of the data points well.

2.6 This nvPM mass concentration regulatory level line can be used for certification purposes for the proposed CAEP/10 standard. Since this regulatory level is based on the existing SN regulatory limit line, the characteristic value and the associated corrections would also follow the existing SN protocol. Thus, the same coefficients, which depend on the number of engines tested, would apply.

B. RATIONALE FOR THE REPORTING OF THE NVPM MASS AND NUMBER EMISSION INDICES

1. In parallel to CAEP/10 nvPM standard, Annex 16, Vol. II requires the reporting of the nvPM mass and number emission indices and other data that would feed the cost-effectiveness analyses and support the development of nvPM mass and number LTO based standards. The requirement applies to all in-production engines with a rated thrust greater than 26.7kN from 01/01/2020.
2. The next nvPM standard should be LTO based and take into account mass and number. The plan is to gather enough data from 25 representative engines by February 2017 for the development of a sensitive standard that would serve as a basis for future stringency options.
3. The nvPM mass and number emission indices reporting in parallel with other useful data is required to guarantee the collection of sufficient data for the assessment of future standard.

**C. RATIONALE FOR REPORTING OF NVPM SYSTEM
LOSS CORRECTION FACTORS**

1. The nvPM sampling and measurement system will lose a portion of the particles when they travel through the sampling lines because of very small size of the nvPM particles. Therefore, the nvPM emissions measured at the instruments will be lower than the values at the engine exit plane.
2. The purpose of emission certification is to compare engine technologies and to ensure that the engines produced comply with the prescribed regulatory limits. The nvPM sampling and measurement system requirements as described in Annex 16, Vol.II, Appendix 7 to Chapter 4 standardise the system such that the particle losses are minimised and that engine measurements performed by different engine manufacturers and test facilities can be compared directly.
3. However, for emission inventories and impact assessments, nvPM emissions at the engine exit should be estimated through application of a standardised methodology to better reflect these emissions. For that purpose Part IV to Annex 16, Vol.II and its related Appendix 8 were created. The recommended methodology for the calculation of the correction factors to estimate system losses is provided in Appendix 8 to Part IV. Part IV recommends that the engine manufacturers report their nvPM system loss correction factors to the appropriate authority using this recommended methodology. Using the same methodology will ensure to get correction factors calculated on a common basis. Getting these emissions factors at the authority level is a first step. There is a need to discuss a process that will enable modellers to access these factors for their emission inventories and impact assessments.

Agenda Item 5: CO₂ Standard development

5.1 CO₂ STANDARD DEVELOPMENT

5.1.1 The CO₂ Task Group (CO₂TG) co-lead provided an overview of the work undertaken by the CO₂TG to develop the ICAO Aeroplane CO₂ Emissions Standard. This included details on the CAEP/10 WG3 CO₂ work programme and on the proposed edits to the draft Annex 16, Volume III approved at CAEP/9, and subsequently published as ICAO Circular 337. This updated version formed the basis of the proposal for the First Edition of Annex 16, Volume III – Aeroplane CO₂ Emissions. This was followed by the presentation of the proposed First Edition of Annex 16, Volume III and ICAO Doc 9501, Environmental Technical Manual (ETM), Volume III. An overview was also provided of potential future ETM, Volume III work items. The CO₂TG has continued to investigate the development of the ICAO CO₂ Certification Database and CO₂TG has developed a spreadsheet detailing the structure and data requirements for three options, as well as some draft Introduction text for the CO₂DB website.

5.1.2 The CO₂TG co-lead provided an overview of the work undertaken to develop potential CO₂ applicability options for in-production (InP) aeroplane types. The 2015 CAEP Steering Group (SG2015) had agreed on three potential mandatory in-production applicability options, and these were as follows:

- 1) Option 1 represents a production cut-off for all InP aeroplane types if they have not been certified to the CO₂ Standard by this date.
- 2) Option 2 represents applicability being triggered only if an application for a design change for new in-production aeroplanes exceeds a specific CO₂ change criteria.
- 3) Option 3 represents a hybrid approach, where Option 2 is active for a period of time and is subsequently followed by Option 1.

5.1.3 CO₂TG had been requested to develop proposed Annex 16, Volume III text for the three options in preparation for a potential decision at CAEP/10. The CO₂TG co-lead provided the proposed edits to Annex 16, Volume III, which could be used to integrate the proposed InP applicability options should they form part of the final decision on a CO₂ Standard.

5.1.4 The meeting discussed the difference between a new type (NT) and InP aeroplane. It was clarified that a NT aeroplane is a new design for which the Type Certificate application was submitted following any applicability date of the CO₂ Standard. InP refers to those aeroplane types which have already submitted an application for, or received, a Type Certificate before any applicability date of the CO₂ Standard. It was added that a derived version of an aeroplane incorporates changes in type design that meet certain criteria. If the changes to an InP aeroplane type are determined to be substantial then the design would be considered a new type design. Following a question from member, it was clarified that a substantial change is challenging to define but there is significant harmonisation on the process to do this across authorities.

5.1.5 The MDG and FESG co-Rapporteurs presented a high level summary of results from the environmental (benefits) and economic (costs) assessment of stringency options (SOs) for a potential CO₂ Standard under consideration by CAEP/10. The information presented was an update to the joint MDG/FESG papers provided to the SG2015, regarding the MDG/FESG analyses for a potential CO₂

Standard under the CAEP/10 work programme. The CO₂ main analysis (CO₂ma) has been conducted in accordance with the following framework to consider CO₂ Standard application to NT aeroplanes and new deliveries of InP aeroplane types.

5.1.5.1 NT and InP: Full Technology Response (TR) / Out of Production Case (Case-1): This involved the analysis of CAEP Steering Group agreed SOs at the agreed implementation dates using all technology responses defined by WG3/WG1 –and– aircraft are assumed to go out of production (OoP) at the implementation dates if they cannot be made compliant to a stringency option level.

5.1.5.2 NT-Only: Alternative Response / Production Case (Case-4): This involved the analysis of CAEP Steering Group agreed SOs at agreed implementation dates for NT-only applicability using responses informed by market considerations since manufacturers would not have a legal deadline to bring InP types to levels required under an NT-only standard. Case-4 can be thought of as a range of response scenarios from a voluntary response similar to Case-1 down to an absence of any response by growth and replacement aircraft; and, within that range Case-4 was summarized as follows: Case-4-A included the top 33% most likely families respond and non-compliant families go out of production, unless no aircraft types remain to meet distance band demand, Case-4-B involved repeating Case-4-A with the B767 family remaining in production without a TR, and Case-4-C involved the top 33% most likely families respond and non-compliant families remain in production.

5.1.5.3 Hybrid Applicability: This involved the CO₂ Standard application to NT aeroplanes prior to new deliveries of InP types that allows for potentially combining a higher SOs for NT applicability with a lower SO for InP applicability.

5.1.6 The meeting discussed the impact fuel price has on the results of the CO₂ma. Following a question from a member, it was confirmed that when the fuel price is lower the environmental benefit shown for the CO₂ Standard in the analysis will be greater because there is less pressure from the market. It was confirmed that a range of fuel prices had been tested (USD 2.00 to 4.00 per gallon) but this did not include the impact of the current low oil price.

5.1.7 An observer made the assertion, and the FESG co-Rapporteur confirmed, that the additional CO₂ benefits gained beyond SO6 in the hybrid results are smaller than the gains at the lower SOs. A member urged caution with drawing this conclusion and recommended not to focus on one single number in the CO₂ma, highlighting that many assumptions had been made that can drive this modelled behaviour. The member commented that CAEP should focus on the breadth of the analysis conducted by MDG/FESG. An observer asked for clarification regarding the high capital cost for SO9 compared to SO8, and the MDG co-rapporteur confirmed that the increase in capital cost was due to a larger aircraft in a Competition Bin (CBin) dropping out, increasing the purchase of smaller size aircraft to meet demand.

5.1.8 The meeting thanked MDG and FESG for the immense amount of work and dedication in completing the CO₂ma. The meeting accepted the results of the CO₂ma as presented by MDG and FESG.

5.1.9 The WG1, WG3, MDG, FESG (WMF) coordination group liaison provided an overview of progress against the ICAO CO₂ Standard schedule approved at CAEP/9. All deliverables for CAEP/10 have been met, which were, the CO₂ma and sensitivity tests by MDG/FESG; and the Annex 16, Volume III amendments, ETM Volume III and InP applicability options. The completion of this substantial body of work should provide CAEP with the information it requires to make a recommendation on the CO₂ Standard. The meeting thanked the WMF coordination group for all the efforts in coordinating the CO₂ Standard work.

5.1.10 The CO₂ Standard Members Group, established at SG2015 to develop and assess various compliance options for the proposed CO₂ Aeroplane Standard, provided a summary of the flexible compliance options for the CO₂ Standard that were discussed by the group. These included exclusions, exemptions, SO Combinations, and different effective dates and InP applicability options. It was highlighted that a face-to-face meeting of the CO₂ Standard Members Group was held in Zurich, Switzerland with the objective to deepen the technical discussions and to give the opportunity to stakeholders and aircraft manufacturers to share their views on the CO₂ Aeroplane Standard.

5.1.11 An observer highlighted that several CAEP members are advocating for a decoupling of stringency lines for aeroplanes whether their MTOM is above or below 60t to additionally mitigate the technical challenges confronted by aeroplanes with MTOM below 60t. To aid the discussions the observer presented views on the selection of the connection methodology between two different SOs. The observer urged CAEP to carefully consider both the selection of SOs and the connection methodology, so as to minimize unintended consequences and because the two are intrinsically intertwined. The observer also offered support to help develop final transition proposals once the SO levels above and below 60t are defined.

5.1.12 A member provided guidance on connecting CO₂ SOs. It was highlighted that with the possibility that SOs may be different below and above the previously established 60t MTOM kink point, the need to better understand how SOs can be connected is crucial. The member offered potential guiding principles and described two methods with examples that may be considered.

5.1.13 Several members and observers presented their views on the different aspects to be considered regarding the CO₂ Standard. They supported, for New Types greater than 60t MTOM, not less than SO7 with an applicability date of 1 January 2020, and for InP aeroplanes, not less than SO6 with an Option 1 applicability trigger in 1 January 2023. These positions allow to have a uniform applicability of the standard across the entire fleet, avoiding any exemptions or adaptations, especially for dedicated freighters. It was recognised that in general aeroplanes less than or equal to 60t MTOM have different challenges compared to aeroplanes above 60t with regards to CO₂ emissions reductions. Some disadvantage to these aeroplanes stem from the technology not being scalable for technical or economic reasons. Several members and observers suggested not less than SO6 with an applicability date of 1 January 2020 for NT aeroplanes less than or equal to 60t MTOM and greater than 19 seats, and in this mass and seat category for InP aeroplanes not less than SO5 with an Option 1 applicability trigger in 1 January 2023 was acceptable. For aeroplanes less than or equal to 60t MTOM and less than or equal to 19 seats (excluding freighters) a NT Standard of SO5 with an applicability date of 1 January 2023 was proposed. For InP aeroplanes, SO4 with an Option 1 applicability trigger in 1 January 2025 was suggested. The several members and observers highlighted that they were open to considering 'flexible compliance options' for InP aircraft. These should be of a limited nature in order to ensure that the purpose of the standard is not undermined. After a decision has been taken, it will be crucial that the information can be obtained by the member States for their rulemaking processes.

5.1.13.1 A member asked about the rationale behind the proposal of a particular SO for aeroplanes with less than or equal to 60t MTOM and with less than or equal to 19 seats. It was clarified that this aimed to address concerns with the impact of CO₂ Standard on the business jet market and how this may limit the scope of the chosen SOs for the heavier aeroplanes. It was added that this criteria has also been used in various national and regional regulations.

5.1.14 A member stated that the new ICAO Aeroplane CO₂ Standard should be applied to both NT and InP aeroplanes. It was highlighted that the adoption of a single SO level to NT and InP aeroplanes was unrealistic and the adoption of a single SO level to aeroplanes below and above the 60t MTOM kink could be problematic. The member supported the adoption of SO5 to NT aeroplanes less than or equal to

60t MTOM and SO7 for aeroplanes above the 60 tonne MTOM. The member supported the adoption of SO3 for InP aeroplanes less than or equal to 60t MTOM and SO5 for aeroplanes above 60t MTOM. While the date of 2020 seems to be a reasonable applicability date for NT aeroplanes, for InP aeroplanes, the member supported an applicability date of 2023, using Option 3, with a Production Cut-off date of 2028. The member supported the use of an exclusion criteria in Annex 16, Volume III with procedures included in ETM, Volume III, and supported the inclusion of a mechanism to avoid possible backsliding in fuel efficiency for products that are excluded.

5.1.15 A member expressed concerns over making the CO₂ Standard applicable to InP aeroplanes because the capability to implement the best modern CO₂ emission reduction technologies in InP aeroplane designs is limited. Should CAEP decide to recommend the application of the CO₂ Standard to InP aeroplanes, the member proposed a limit line no stricter than SO2, with an applicability date of 2023 (InP applicability Option 2) or with an applicability date not earlier than 2023 and a production cut-off date not earlier than 2028 (InP applicability Option 3). Regarding the CO₂ Standard for NT aeroplanes, the member proposed a SO no stricter than SO6. Taking into account the specific features of smaller aeroplanes, additional flexible options could be acceptable for such aeroplanes. The member suggested that the basic principles regarding exemptions of aeroplanes from the applicability of the CO₂ Standard, justified by technical reasons, could be described in the ETM, Vol III, and that the final decision should be the responsibility of individual States.

5.1.16 A member presented their views on the CO₂ Standard, supporting for NT aeroplanes above 60t MTOM SO8 or SO9 (maximum) with an applicability date of 1 January 2020, and for less than or equal to 60t MTOM SO5 with an applicability date of 1 January 2020. For InP aeroplanes above 60t MTOM, SO6 with an Option 3 applicability trigger in 1 January 2023 and with a production cut-off date of 1 January 2028 would be acceptable. For less than or equal to 60t MTOM, SO2 with an Option 3 applicability trigger in 1 January 2023 and with a production cut-off date of 1 January 2028 was appropriate. It was added that for aeroplanes less than or equal to 60t MTOM and less than or equal to 19 seats, it should be left to NAAs to adopt more flexible compliance options.

5.1.17 A member supported a separation of regulations above and below the 60t kink point based on technological feasibility. For aeroplanes above 60t MTOM, the member recommended a NT stringency level at SO9 with an applicability date of 2020, and an InP stringency level at SO8 or SO9 with an applicability date of 2023 under applicability Option 1 (production cut off). It was suggested that flexibilities for InP dedicated freighters would be essential for a technologically feasible standard. For aeroplanes less than or equal to 60t MTOM, the member recommended a NT stringency level of SO6 with an applicability date of 2020, and an InP stringency level at SO5 with an applicability date of 2025 under an applicability option of 1 (production cut off). The member stated that the Standard reflects technology innovation and is not to be used as the basis for operational restrictions or charges.

5.1.17.1 In referring to the assertion that the CO₂ Standard should not be used as a basis for operating restrictions or charges, a member questioned whether this would be acceptable if the chosen SO was low. In following up, a member stated that the CO₂ Standard not being the basis for operating restrictions was an important clause. The CO₂ Standard should not restrict access to airports. It is associated with aiming for sustainable development of international civil aviation.

5.1.17.2 The meeting discussed flexibilities for InP dedicated freighters and it was suggested by an observer, and accepted by a member, that Option 3 from the InP applicability options could form part of the construct on InP freighters.

5.1.18 A member supported SO9 for NT aeroplanes at greater than 60t MTOM with an applicability date of 2020, and for less than or equal to 60t MTOM SO6 with an applicability date of

2020. For InP aeroplanes greater than 60t MTOM SO8 or greater with an trigger date of 2023 was supported. For less than or equal to 60t MTOM and greater than 19 seats, this should be SO5 with an applicability date of 2023 and for less than or equal to 19seats, SO3 with an applicability date of 2023 was agreeable. The member supported InP Option 3 with applicability dates of 2023 and 2028.

5.1.19 A member commented that the environmental benefit analysis conducted by MDG is comprehensive. Concerns were however raised over the economic analyses and it was suggested that above SO5 the modelled costs are questionable. The member continued to present further views on the CO₂ Standard, supporting for NT aeroplanes above 60t MTOM SO5 with an applicability date of 2020 and for less than or equal to 60t MTOM SO5 with an applicability date of 2023. For InP aeroplanes, for all MTOMs, SO2 with an applicability date of 2023, option 3, with a production cut-off in 2028 was proposed.

5.1.20 An observer provided its perspective on the NT and InP CO₂ standard, and potential exceptions / exemptions. The observer proposed for aeroplanes with an MTOM greater than or equal to 70.265t the adoption of the SO6 stringency level for NT aeroplanes with an applicability date of 1 January 2020. For aeroplanes with a MTOM less than 70.265t, the adoption of SO5 stringency level for NT with an implementation date set at 1 January 2023 was acceptable. The observer suggested that when developing future updates of the CO₂ emissions standard, for business jet aeroplanes, a review of the implications of the CAEP/10 CO₂ certification requirement on aeroplane designs should be performed. If deemed necessary, for an InP CO₂ Standard a limit line of no higher than SO2 was acceptable, with Option 2 beginning on 1 January 2023. The observer highlighted that if a production cut-off was agreed, then Option 3 beginning on 1 January 2023 with an end date of 1 January 2028 was appropriate. The observer recommended that if exemptions are granted for InP certifications, the process must follow unambiguous and published rules to be included in Annex 16, Volume III.

5.1.21 A member raised a concern that setting an InP CO₂ Standard with a limit line of no higher than SO2 would not meet the CAEP tenet of delivering environmental benefit. Regarding the suggestion to set the kink point at 70.265 MTOM, it was clarified that this aimed to minimise market distortions and was the result of joining two SOs together. The observer clarified that other kink points may be required depending on the selection of the SOs.

5.1.22 The meeting discussed exemptions and it was highlighted by an observer that these can be effective but should only be used as method of last resort. Members added that the use of exemptions is common place across aviation regulations (e.g. airworthiness) and can be successfully to address particular issues of members and observers as long as they are carefully constructed.

5.1.23 An observer recommended that for NT aeroplanes below approximately 60t MTOM, SO5, applicable no earlier than 1 January, 2023 was acceptable. It was stated that in the event of a difference in stringency between aeroplanes above and below 60t, a smooth and continuous transition should be employed between the two stringency lines, minimizing potential market distortions for aeroplanes in and around the transition area. The observer suggested that if the CAEP/10 meeting decides that InP applicability is necessary, a change-based InP standard (Option 2 with no production cut-off) set at SO2 would be appropriate, which covers the entire scope of MTOM values, applicable no earlier than 1 January, 2020.

5.1.24 The meeting took note of all the positions and technical information provided by the member and observers thus far. The Chairperson highlighted that with this solid basis, the CAEP/10 meeting should be able to move forward to make a decision on the CO₂ Standard.

5.1.25 An observer considered the aeroplane CO₂ emissions Standard to be an essential step to continually improving the environmental performance of the aviation industry. The observer underlined the importance that the Standard meet the CAEP's Terms of Reference (TORs) and described its position on potential accommodations for aeroplane categories, which may set unwise precedents, have unintended consequences, and unfairly shift the burden of the CO₂ Standard. CAEP was urged to ensure the impact on operators is fully taken into account when setting the CO₂ Standard. The observer also urged CAEP to recommend that States should not adopt CO₂ emissions standards that deviate from any agreed ICAO standard and to not restrict the operation of aircraft that are not subject to or comply with the agreed ICAO CO₂ Standard. The observer highlighted that for a NT CO₂ Standard greater than 60t SO8 at 2020 was appropriate, and for less than or equal to 60t the preferred choice was SO6 at 2020. For an InP CO₂ Standard, greater than 60t SO5 and for less than or equal to 60t SO4, both in 2023 with Option 3 (2028), were the preferred choices.

5.1.26 The meeting discussed how the CO₂ Standard might impact operators and how this impact was calculated. The observer clarified that policymakers should recognize that "economic reasonableness" encompasses economic effects other than "bottom line" costs and to weigh these effects carefully. For example, where a standard unduly limits aircraft availability and/or capability, aircraft operators will have more difficulty matching their aircraft purchases and fleets to efficiently serve market demands. The observer clarified that the analysis of the impact on operators was based on data from the CO₂ma. The member raised a concern regarding the use of older (~5 years) economic data to underpin the cost analysis in the CO₂ma and highlighted that the economic analysis could be more robust. The meeting noted these concerns while acknowledging that the best available data had been used by MDG/FESG in the CO₂ma to aid the decision of CAEP on the CO₂ Standard. The meeting agreed that consistency should be ensured with all elements of the CAEP Terms of Reference during the development of the CO₂ Standard.

5.1.27 An observer noted that new certification standards should push forward aircraft technological improvements and should not imply or result in operating or operational restrictions.

5.1.28 An observer suggested that in order to provide demonstrable environmental benefit, ICAO's CO₂ Standard must require additional efficiency improvements from future aeroplanes beyond that expected due to market forces alone. The observer made recommendations on the standard stringency, flexibility, applicability, and data transparency to support an environmentally-effective CAEP/10 CO₂ Standard. These include: SO10 for all NT aeroplanes, to be applied from 2020; SOs 10 and 8 for new InP aircraft above and below 60t MTOM, respectively, to be applied from 2023; the application of the Standard to InP aeroplanes via a production cut off; and the "detailed" option for data to be included in the ICAO CO₂ Certification Database.

5.1.29 A member highlighted that for a NT CO₂ Standard greater than 60t SO8 in 2020 was appropriate, and for less than or equal to 60t her preferred choice was SO6 in 2020. The member highlighted that for InP applicability greater than 60t at SO8 and less than or equal to 60t SO5, both in 2023 and with applicability Option 3 in 2028 was appropriate.

5.1.30 A member highlighted his position on the CO₂ Standard as, for NT aeroplanes greater than 60t at SO9 in 2020, and less than or equal to 60t at SO6 in 2020. For InP applicability, greater than 60t at SO8 and less than or equal to 60t at SO5, both in 2023 and with applicability Option 3 in 2028 was acceptable. Another member stated his bottom line (minimum), for NT aeroplanes greater than 60t SO7 and less than or equal to 60t at SO6, both in 2020 was acceptable. For InP applicability, greater than 60t at SO6 and less than or equal to 60t at SO5, both with applicability Option 1 in 2023 was appropriate.

5.1.31 Several members commented on the objectives of the CO₂ Standard, and it was made clear that aviation must do its fair share in reducing global CO₂ emissions. They agreed that it was therefore important to set a NT and InP CO₂ Standard as soon as possible for aeroplanes greater than 60 MTOM. The CO₂ Standard should be ambitious but fair. A member raised a concern over the impact of employing higher SOs greater than 60T MTOM, stating the impact of a production cut off must be fully understood. Several members highlighted that consideration of a limited set of flexible compliance options should be given consideration. One member was convinced that market driven forces will continue to be an important incentive for the industry to produce more fuel efficient aircraft types and that some of the lower SO would result in a Standard that would not show any environmental benefit at all or an effectiveness that would quickly diminish.

5.1.32 An observer added that airports and the aviation industry requires ICAO to have a roadmap on addressing aviation CO₂ emissions that is effective, comprehensive and environmentally-beneficial and the CO₂ Standard is a key part of this. The observer supported having both NT and InP applicability and any InP production cut off requirement should be unambiguous.

5.1.33 The WMF liaison presented an overview of work following the 2015 Steering Group meeting to define the content of the information on Annex 16 amendments which could be made public following the CAEP meeting to support the rulemaking processes of all ICAO Member States. The high-level State requirements for information from some States have been identified and processes for potential release of information have been examined by the Group. The result of the group discussions was to recommend that the material required for release be agreed by CAEP, and included in the CAEP/10 Report.

5.1.34 The ICAO Secretariat presented an overview of a draft summary of the input material to the CO₂ Standard-setting process in order support the public rulemaking processes of a number of ICAO Member States. The draft has been reviewed by the WMF group. If agreed by the CAEP/10 meeting, this summary, as well as any additions agreed by the meeting, could be included as part of the CAEP/10 meeting report.

5.1.35 The meeting discussed the draft material to support the public rulemaking processes on the ICAO CO₂ Aeroplane Standard. The meeting showed its appreciation for the work and several members voiced their support for the document to be included in the CAEP/10 report. However, many members cautioned that the material would need review after the Standard stringency was set to ensure the relevance and accuracy of the material. It was agreed that a review by the CAEP/10 meeting should be conducted and the working group co-Rapporteurs should review the material and inform the meeting accordingly.

Discussion and Conclusions

5.1.36 The Chairman summarised, stating that the meeting had heard all the positions from the members and observers and highlighted that the aim of this meeting was to reach a consensus on an environmentally beneficial and cost effective ICAO CO₂ emissions certification Standard. The CO₂ Standard is a critical element of the basket of measures that aim to limit or reduce the impact of aviation greenhouse gas emissions on the global climate.

5.1.37 Following an extensive discussion amongst the CAEP Members, a consensus was reached on the overall package for the ICAO CO₂ emissions certification Standard. The meeting agreed to the following:

- for New Type aeroplanes greater than 60t MTOM, a stringency level of SO8.5 with an applicability date of 2020;
- for New Type aeroplanes less than or equal to 60t MTOM, a stringency level of SO5.0 with an applicability date of 2020, and a later applicability date of 2023 for aeroplane type designs with a passenger seating capacity of equal to or less than 19 seats;
- for in-production aeroplanes greater than 60t MTOM, a stringency level of SO7.0 with applicability trigger option 3, an applicability date of 2023 and production cut-off of 2028.
- for in-production aeroplanes less than or equal to 60t MTOM, a stringency level of SO3.0 with applicability trigger option 3, an applicability date of 2023 and production cut-off of 2028.

5.1.38 Regarding the different stringency levels for InP and NT respectively, the meeting agreed that these stringency levels will be connected using a “plateau” approach (i.e. a horizontal line). The horizontal line will start at 60t MTOM and end at the intersection of the associated stringency level above 60t MTOM.

5.1.39 To provide flexibility for certain aeroplanes with low volume production the members decided on sensible exemption criteria. This will allow certificating authorities to exempt low volume production aeroplanes in exceptional circumstances, taking into account environmental assessment, cost, social responsibility and circumstances of force majeure. It was also agreed that in addition of initial SARPS in Annex 16 and guidance on the ETM, specific exemption criteria will be defined by WG3 in time for the 2016 Steering Group meeting (SG2016).

5.1.40 Recognizing the ongoing and continuous improvement of aircraft technologies and the importance of reflecting technology developments in the ICAO standard-setting process, the meeting agreed that CAEP will, as is done with other standards, periodically review aircraft technology and assess the stringency level of the CO₂ Standard, with the first technology review being initiated in 2016 and concluding by CAEP/11 in 2019.

5.1.41 The meeting recalled the principles and purpose of the CO₂ Standard and specifically that the CO₂ emissions certification Standard of Annex 16, Vol. III is a technical comparison of aviation technologies designed to be used for CO₂ certification processes. The meeting recognised that the Standard was not designed to serve as a basis for operating restrictions or emissions levies.

5.1.42 The meeting agreed that, in a similar way to noise and engine emissions, an ICAO CO₂ Certification Database (CO2DB) should be developed. The meeting confirmed that it should be public and that the United States would host it on behalf of ICAO. The meeting recognised the information submitted by WG3 on the data approaches for the CO2DB (i.e. Metric Value, SAR and Detailed approaches) and that technical discussions in WG3 had progressed as far as they could. However, there was a need for WG3 to consider how to incorporate information on exempted aeroplanes in the CO2DB and this should be reported to SG2017, where a decision would be taken on the CO2DB data approach.

5.1.43 To aid States in the implementation of the new ICAO CO₂ Standard, the meeting approved a summary of information detailing the input provided to the meeting in order to facilitate the decision on the new Annex 16, Volume III, as indicated in Appendix C to this Agenda Item.

5.1.44 Recommendations

5.1.44.1 In light of the foregoing discussion, the meeting developed the following recommendations:

RSPP | **Recommendation 5/1 — Amendments to Annex 16 —
*Environmental Protection, Volume III — Aeroplane CO₂
Emissions***

That Annex 16 be amended to include the First Edition of Annex 16, Volume III, entitled *Aeroplane CO₂ Emissions*, as indicated in Appendix A to the report on this agenda item.

Recommendation 5/2 — First Edition of the *Environmental Technical Manual, Volume III - Procedures for the CO₂ Emissions Certification of Aeroplanes*

That the *Environmental Technical Manual, Volume III* be published, as indicated in Appendix B to the report on this agenda item, and revised versions approved by subsequent CAEP Steering Group Meetings be made available, free of charge on the ICAO website, pending a final decision on official publication by the ICAO Secretary General.

Recommendation 5/3 — Use of the CO₂ Emissions Standard

That States recognize that the CO₂ emissions certification Standard of Annex 16, Volume III is a technical comparison of aviation technologies designed to be used for CO₂ emissions certification processes. The Standard was not designed to serve as a basis for operating restrictions or emissions levies.

APPENDIX A**ANNEX 16 VOL. III PROPOSED CLEAN TEXT FOR FIRST EDITION****PROPOSED AMENDMENTS TO THE
INTERNATIONAL STANDARDS AND RECOMMENDED PRACTICES****ENVIRONMENTAL PROTECTION
ANNEX 16****TO THE CONVENTION ON INTERNATIONAL CIVIL AVIATION
VOLUME III****AEROPLANE CO₂ EMISSIONS**

The text of the amendment is arranged to show deleted text with a line through it and new text highlighted with grey shading, as shown below:

1. ~~Text to be deleted is shown with a line through it.~~ text to be deleted
2. **New text to be inserted is highlighted with grey shading.** new text to be inserted
3. ~~Text to be deleted is shown with a line through it~~ followed **by the replacement text which is highlighted with grey shading.** new text to replace existing text

PROPOSED TEXT FOR ANNEX 16, VOLUME III, FIRST EDITION
INTERNATIONAL STANDARDS AND RECOMMENDED PRACTICES
ENVIRONMENTAL PROTECTION
ANNEX 16
TO THE CONVENTION ON INTERNATIONAL CIVIL AVIATION
VOLUME III
AEROPLANE CO₂ EMISSIONS

TABLE OF CONTENTS

	<i>Page</i>
Foreword.....	(vii)
Part I. DEFINITIONS AND SYMBOLS	I-1-1
CHAPTER 1. Definitions.....	I-1-1
CHAPTER 2. Symbols.....	I-2-1
Part II. CERTIFICATION STANDARD FOR AEROPLANE CO₂ EMISSIONS BASED ON THE CONSUMPTION OF FUEL	II-1-1
CHAPTER 1. Administration.....	II-1-1
CHAPTER 2.	
1. Subsonic jet aeroplanes over 5 700 kg	
2. Propeller-driven aeroplanes over 8 618 kg.....	II-2-1
2.1 Applicability.....	II-2-1
2.2 CO ₂ emissions evaluation metric.....	II-2-2
2.3 Reference aeroplane masses.....	II-2-2
2.4 Maximum permitted CO ₂ emissions evaluation metric value.....	II-2-2
2.5 Reference conditions for determining aeroplane specific air range.....	II-2-2
2.6 Test procedures.....	II-2-3

APPENDICES

APPENDIX 1. Determination of the aeroplane CO₂ emissions evaluation metric value

1. Subsonic jet aeroplanes over 5 700 kg	
2. Propeller-driven aeroplanes over 8 618 kg.....	APP 1-1
1. Introduction.....	APP 1-1
2. Methods for determining specific air range.....	APP 1-1

3. Specific air range certification test and measurement conditions.....	APP 1-2
4. Measurement of aeroplane specific air range	APP 1-4
5. Calculation of reference specific air range from measured data.....	APP 1-6
6. Validity of results	APP 1-7
7. Calculation of the CO ₂ emissions evaluation metric value.....	APP 1-7
8. Reporting of data to the certificating authority.....	APP 1-8
APPENDIX 2. Reference geometric factor.....	APP 2-1



FOREWORD

Historical background

Standards and Recommended Practices for Environmental Protection were first adopted by the Council on 2 April 1971 pursuant to the provisions of Article 37 of the Convention on International Civil Aviation (Chicago, 1944) and designated as Annex 16 to the Convention. This Volume III to Annex 16 was developed in the following manner:

At the 36th Session of the ICAO Assembly in 2007, Contracting States adopted Assembly Resolution A36-22 *Consolidated statement of continuing ICAO policies and practices related to environmental protection*. This resolution provided for the establishment of a process which led to the development and recommendation to the Council a Programme of Action on International Aviation and Climate Change and a common strategy to limit or reduce greenhouse gas emissions attributable to international civil aviation.

The development of an aeroplane CO₂ standard as part of the range of measures for addressing greenhouse gas emissions from international aviation was one of the recommended elements within the ICAO Programme of Action on International Aviation and Climate Change. This was subsequently endorsed by the ICAO High Level Meeting of Member States in October 2009.

In line with the ICAO Programme of Action, the Eighth Meeting of the Committee on Aviation Environmental Protection (CAEP/8) in February 2010 agreed to develop International Standards and Recommended Practices for Aeroplane CO₂ Emissions. This was approved by the ICAO Council in May 2010. Subsequently the 37th Session of the ICAO Assembly in 2010 adopted resolutions A37-18 and A37-19, requesting that the Council develop a global CO₂ Standard for aircraft. The CAEP developed draft International Standards and Recommended Practices for aeroplane CO₂ emissions and, after amendment following the usual consultation with the Contracting States of the Organisation, this Annex 16, Volume III was adopted by the Council.

Table A shows the origin of amendments to the Annex 16 Volume III over time together with a list of the principal subjects involved and the dates on which the Annex and the amendments were adopted by the Council, when they became effective and when they became applicable.

Applicability

Part I of Volume III of Annex 16 contains definitions and symbols. Part II contains Standards, Recommended Practices and guidelines for certification of aeroplane CO₂ emissions based on the consumption of fuel applicable to the classification of aeroplanes specified in Part II of Volume III of Annex 16, where such aeroplanes are engaged in international air navigation.

Action by Contracting States

Notification of differences. The attention of Contracting States is drawn to the obligation imposed by Article 38 of the Convention by which Contracting States are required to notify the Organization of any differences between their national regulations and practices and the International Standards contained in this Annex and any amendments thereto. Contracting States are invited to extend such notification to any differences from the Recommended Practices contained in this Annex, and any amendments thereto, when the notification of such differences is important for the safety of air navigation. Further, Contracting States are invited to keep the Organization currently informed of any differences which may subsequently occur, or of the withdrawal of any differences previously notified. A specific request for notification of differences will be sent to Contracting States immediately after the adoption of each amendment to this Annex.

The attention of States is also drawn to the provisions of Annex 15 related to the publication of differences between their national regulations and practices and the related ICAO Standards and Recommended Practices

through the Aeronautical Information Service, in addition to the obligation of States under Article 38 of the Convention.

Use of the Annex text in national regulations. The Council, on 13 April 1948, adopted a resolution inviting the attention of Contracting States to the desirability of using in their own national regulations, as far as is practicable, the precise language of those ICAO Standards that are of a regulatory character and also of indicating departures from the Standards, including any additional national regulations that were important for the safety or regularity of international air navigation. Wherever possible, the provisions of this Annex have been written in such a way as to facilitate incorporation, without major textual changes, into national legislation.

Status of Annex components

An Annex is made up of the following component parts, not all of which, however, are necessarily found in every Annex; they have the status indicated:

1.— Material comprising the Annex proper:

- a) *Standards and Recommended Practices* adopted by the Council under the provisions of the Convention. They are defined as follows:

Standard: Any specification for physical characteristics, configuration, material, performance, personnel or procedure, the uniform application of which is recognized as necessary for the safety or regularity of international air navigation and to which Contracting States will conform in accordance with the Convention; in the event of impossibility of compliance, notification to the Council is compulsory under Article 38.

Recommended Practice: Any specification for physical characteristics, configuration, material, performance, personnel or procedure, the uniform application of which is recognized as desirable in the interest of safety, regularity or efficiency of international air navigation, and to which Contracting States will endeavour to conform in accordance with the Convention.

- b) *Appendices* comprising material grouped separately for convenience but forming part of the Standards and Recommended Practices adopted by the Council.
- c) *Provisions* governing the applicability of the Standards and Recommended Practices.
- d) *Definitions* of terms used in the Standards and Recommended Practices which are not self-explanatory in that they do not have accepted dictionary meanings. A definition does not have an independent status but is an essential part of each Standard and Recommended Practice in which the term is used, since a change in the meaning of the term would affect the specification.

2.— Material approved by the Council for publication in association with the Standards and Recommended Practices:

- a) *Forewords* comprising historical and explanatory material based on the action of the Council and including an explanation of the obligations of States with regard to the application of the Standards and Recommended Practices ensuing from the Convention and the Resolution of Adoption.
- b) *Introductions* comprising explanatory material introduced at the beginning of parts, chapters or sections of the Annex to assist in the understanding of the application of the text.
- c) *Notes* included in the text, where appropriate, to give factual information or references bearing on the Standards or Recommended Practices in question, but not constituting part of the Standards or Recommended Practices.

- d) *Attachments* comprising material supplementary to the Standards and Recommended Practices, or included as a guide to their application.

Selection of language

This Annex has been adopted in six languages — English, Arabic, Chinese, French, Russian and Spanish. Each Contracting State is requested to select one of those texts for the purpose of national implementation and for other effects provided for in the Convention, either through direct use or through translation into its own national language, and to notify the Organization accordingly.

Editorial practices

The following practice has been adhered to in order to indicate at a glance the status of each statement: *Standards* have been printed in light face roman; *Recommended Practices* have been printed in light face italics, the status being indicated by the prefix **Recommendation**; *Notes* have been printed in light italics, the status being indicated by the prefix *Note*.

It is to be noted that in the English text the following practice has been adhered to when writing the specifications: Standards employ the operative verb “shall” while Recommended Practices employ the operative verb “should”.

The units of measurement used in this document are in accordance with the International System of Units (SI) as specified in Annex 5 to the Convention on International Civil Aviation. Where Annex 5 permits the use of non-SI alternative units these are shown in parentheses following the basic units. Where two sets of units are quoted it must not be assumed that the pairs of values are equal and interchangeable. It may, however, be inferred that an equivalent level of safety is achieved when either set of units is used exclusively.

Any reference to a portion of this document which is identified by a number includes all subdivisions of that portion.

Table A. Amendments to Volume III of Annex 16

<i>Amendment</i>	<i>Source(s)</i>	<i>Subject(s)</i>	<i>Adopted Effective Applicable</i>
1st Edition	Tenth Meeting of the Committee on Aviation Environmental Protection		xx March 20xx xx July 20xx xx November 20xx

INTERNATIONAL STANDARDS AND RECOMMENDED PRACTICES

PART I. DEFINITIONS AND SYMBOLS

CHAPTER 1. DEFINITIONS

Aeroplane. A power-driven heavier-than-air aircraft, deriving its lift in flight chiefly from aerodynamic reactions on surfaces which remain fixed under given conditions of flight.

Cockpit crew zone. The part of the cabin that is exclusively designated for cockpit crew use.

Derived version of a non-CO₂-certified aeroplane. An individual aeroplane that conforms to an existing Type Certificate, but which is not certified to Annex 16 Volume III, and to which changes in type design are made prior to the issuance of the aeroplane's first certificate of airworthiness that increase its CO₂ emissions evaluation metric by more than 1.5% or are considered to be significant CO₂ changes.

Derived version of a CO₂-certified aeroplane. An aeroplane which incorporates changes in type design that either increase its maximum take-off mass, or that increase its CO₂ emissions evaluation metric value by more than:

- a) 1.35% at a maximum take-off mass of 5 700 kg, decreasing linearly to;
- b) 0.75% at a maximum take-off mass of 60 000 kg, decreasing linearly to;
- c) 0.70% at a maximum take-off mass of 600 000 kg; and
- d) a constant 0.70% at maximum take-off masses greater than 600 000 kg.

Note.— Where the certifying authority finds that the proposed change in design, configuration, power or mass is so extensive that a substantially new investigation of compliance with the applicable airworthiness regulations is required, the aeroplane will be considered to be a new type design rather than a derived version.

Equivalent procedure. A test or analysis procedure which, while differing from the one specified in this volume of Annex 16, in the technical judgement of the certifying authority yields effectively the same CO₂ emissions evaluation metric value as the specified procedure.

Maximum passenger seating capacity. The maximum certificated number of passengers for the aeroplane type design.

Maximum take-off mass. The highest of all take-off masses for the type design configuration.

Performance model. An analytical tool or method validated from corrected flight test data that can be used to determine the SAR values for calculating the CO₂ emissions evaluation metric value at the reference conditions.

Optimum conditions. The combinations of altitude and airspeed within the approved operating envelope defined in the aeroplane flight manual that provides the highest specific air range value at each reference aeroplane mass.

Reference geometric factor. An adjustment factor based on a measurement of aeroplane fuselage size derived from a two-dimensional projection of the fuselage.

Specific air range. The distance an aeroplane travels in the cruise flight phase per unit of fuel consumed.

State of design. The State having jurisdiction over the organization responsible for the type design.

Subsonic aeroplane. An aeroplane incapable of sustaining level flight at speeds exceeding a Mach number of 1.

Type Certificate. A document issued by a Contracting State to define the design of an aircraft type and to certify that this design meets the appropriate airworthiness requirements of that State.



CHAPTER 2. SYMBOLS

Where the following symbols are used in Volume III of this Annex, they have the meanings, and where applicable the units, ascribed to them below:

AVG	Average
CG	Centre of gravity
CO ₂	Carbon dioxide
g ₀	Standard acceleration due to gravity at sea level and a geodetic latitude of 45.5 degrees, 9.80665 (m/s ²)
Hz	Hertz (cycles per second)
MTOM	Maximum take-off mass (kg)
OML	Outer mould line
RGF	Reference geometric factor
RSS	Root sum of squares
SAR	Specific air range (km/kg)
TAS	True air speed (km/h)
W _f	Total aeroplane fuel flow (kg/h)
δ	Ratio of atmospheric pressure at a given altitude to the atmospheric pressure at sea level

PART II. CERTIFICATION STANDARD FOR AEROPLANE CO₂ EMISSIONS BASED ON THE CONSUMPTION OF FUEL

CHAPTER 1. ADMINISTRATION

1.1 The provisions of 1.2 to 1.11 shall apply to all aeroplanes included in the classifications defined for CO₂ certification purposes in Chapter 2 of this part where such aeroplanes are engaged in international air navigation.

1.2 CO₂ emissions certification shall be granted or validated by the State of Registry of an aeroplane on the basis of satisfactory evidence that the aeroplane complies with requirements that are at least equal to the applicable Standards specified in this Annex.

1.3 Contracting States shall recognize as valid a CO₂ emissions certification granted by another Contracting State provided that the requirements under which such certification was granted are at least equal to the applicable Standards specified in this Annex.

1.4 The amendment of this volume of the Annex to be used by a Contracting State shall be that which is applicable on the date of submission to that Contracting State for either a Type Certificate in the case of a new type, approval of a change in type design in the case of a derived version, or under equivalent application procedures prescribed by the certifying authority of that Contracting State.

Note.— As each new edition and amendment of this Annex becomes applicable (according to Table A of the Foreword) it supersedes all previous editions and amendments.

1.5 Unless otherwise specified in this volume of the Annex, the date to be used by Contracting States in determining the applicability of the Standards in this Annex shall be the date the application for a Type Certificate was submitted to the State of Design, or the date of submission under an equivalent application procedure prescribed by the certifying authority of the State of Design.

1.6 An application shall be effective for the period specified in the airworthiness regulations appropriate to the aeroplane type, except in special cases where the certifying authority grants an extension. When the period of effectivity is extended the date to be used in determining the applicability of the Standards in this Annex shall be the date of issue of the Type Certificate, or approval of the change in type design, or the date of issue of approval under an equivalent procedure prescribed by the State of Design, less the period of effectivity.

1.7 For derived versions of non-CO₂-certified aeroplanes and derived versions of CO₂-certified aeroplanes, the applicability provisions concerning the Standards of this Annex refer to the date on which “the application for the certification of the change in type design” was made. The date to be used by Contracting States in determining the applicability of the Standards in this Annex shall be the date on which the application for the change in type design was submitted to the Contracting State that first certified the change in type design.

1.8 Where the provisions governing the applicability of the Standards of this Annex refer to the date on which the certificate of airworthiness was first issued to an individual aeroplane, the date to be used by Contracting States in determining the applicability of the Standards in this Annex shall be the date on which the first certificate of airworthiness was issued by any Contracting State.

1.9 The certifying authority shall publish the certified CO₂ emissions evaluation metric value granted or validated by that authority.

1.10 Subject to the approval of the certificating authority, equivalent procedures may be used in lieu of the procedures specified in the Appendices of this Volume of Annex 16. Guidance material on the use of equivalent procedures is provided in the Environmental Technical Manual (Doc 9501), Volume III – Procedures for the CO₂ Emissions Certification of Aeroplanes.

1.11 Contracting States shall recognize valid aeroplane exemptions granted by an authority of another Contracting State responsible for production of the aeroplane provided that an acceptable process was used.

Recommendation. – Guidance on acceptable processes and criteria for granting exemptions should be used as defined in the Environmental Technical Manual (Doc 9501), Volume III — Procedures for the CO₂ Emissions Certification of Aeroplanes.

CHAPTER 2.

1.—SUBSONIC JET AEROPLANES OVER 5 700 kg

2.—PROPELLER-DRIVEN AEROPLANES OVER 8 618 kg

2.1 Applicability

Note.— See also Chapter 1, 1.4, 1.5, 1.6, 1.7, 1.8 and 1.11.

2.1.1 The Standards of this chapter shall, with the exception of amphibious aeroplanes, aeroplanes initially designed or modified and used for specialised operational requirements, aeroplanes designed with zero RGF, and those aeroplanes specifically designed or modified and used for fire-fighting purposes, be applicable to:

- a) subsonic jet aeroplanes, including their derived versions, of greater than 5 700 kg maximum take-off mass for which the application for a type certificate was submitted on or after 1 January 2020, except for those aeroplanes of less than or equal to 60 000 kg maximum take-off mass with a maximum passenger seating capacity of 19 seats or less;
- b) subsonic jet aeroplanes, including their derived versions, of greater than 5 700 kg and less than or equal to 60 000 kg maximum take-off mass with a maximum passenger seating capacity of 19 seats or less, for which the application for a type certificate was submitted on or after 1 January 2023;
- c) all propeller-driven aeroplanes, including their derived versions, of greater than 8 618 kg maximum take-off mass, for which the application for a type certificate was submitted on or after 1 January 2020;
- d) derived versions of non-CO₂-certified subsonic jet aeroplanes of greater than 5 700 kg maximum certificated take-off mass for which the application for certification of the change in type design was submitted on or after 1 January 2023;
- e) derived versions of non-CO₂ certified propeller-driven aeroplanes of greater than 8 618 kg maximum certificated take-off mass for which the application for certification of the change in type design was submitted on or after 1 January 2023;
- f) individual non-CO₂-certified subsonic jet aeroplanes of greater than 5 700 kg maximum certificated take-off mass for which a certificate of airworthiness was first issued on or after 1 January 2028; and
- g) individual non-CO₂-certified propeller-driven aeroplanes of greater than 8 618 kg maximum certificated take-off mass for which a certificate of airworthiness was first issued on or after 1 January 2028.

Note. – Aeroplanes initially designed or modified and used for specialised operational requirements refer to aeroplane type configurations which, in the view of the certifying authority, have different design characteristics to meet specific operational needs compared to typical civil aeroplane types covered by the scope of this Volume of Annex 16, and which may result in a very different CO₂ emissions evaluation metric value.

2.1.2 Notwithstanding 2.1.1, it may be recognized by a Contracting State that the following situation for aeroplanes on its registry do not require demonstration of compliance with the provisions of the Standards of Annex 16, Volume III:

- a) time-limited engine changes, where the change in type design specifies that the aeroplane may not be operated for a period of more than 90 days unless compliance with the provisions of Annex 16, Volume III, is shown for that change in type design. This applies only to changes resulting from a

required maintenance action.

2.1.3 The granting of an exemption for an aeroplane against applicability requirements specified in 2.1.1 shall be noted on the aeroplane release to service document issued by the certifying authority. Certifying authorities shall take into account the numbers of exempted aeroplanes that will be produced and their impact on the environment. Exemptions shall be reported by aeroplane serial number and made available via an official public register.

Note. - Further guidance on issuing exemptions is provided in the Environmental Technical Manual (Doc 9501), Volume III — Procedures for the CO₂ Emissions Certification of Aeroplanes.

2.2 CO₂ emissions evaluation metric

The metric shall be defined in terms of the average of the 1/SAR values for the three reference masses defined in 2.3 and the RGF defined in Appendix 2. The metric value shall be calculated according to the following formula:

$$\text{CO}_2 \text{ emissions evaluation metric value} = \frac{\left(\frac{1}{\text{SAR}}\right)_{\text{AVG}}}{(\text{RGF})^{0.24}}$$

Note 1. — The metric value is quantified in units of kg/km.

Note 2. — The CO₂ emissions evaluation metric is a SAR based metric adjusted to take into account fuselage size.

2.3 Reference aeroplane masses

2.3.1 The 1/SAR value shall be established at each of the following three reference aeroplane masses, when tested in accordance with these Standards:

- a) high gross mass: 92% MTOM
- b) mid gross mass: Average of high gross mass and low gross mass
- c) low gross mass: $(0.45 \times \text{MTOM}) + (0.63 \times (\text{MTOM}^{0.924}))$

Note. — MTOM is expressed in kilograms.

2.3.2 CO₂ emissions certification for MTOM also certifies CO₂ emissions for take-off masses less than MTOM. However, in addition to the mandatory certification of CO₂ metric values for MTOM, applicants may voluntarily apply for the approval of CO₂ metric values for take-off masses less than MTOM.

2.4 Maximum permitted CO₂ emissions evaluation metric value

The CO₂ emissions evaluation metric value, when determined in accordance with the evaluation methods of Appendix 1, shall not exceed the value defined in the following paragraphs:

- a) For aeroplanes specified in 2.1.1 a), b) and c) with a maximum take-off mass less than or equal to 60 000 kg:

$$\text{Maximum permitted value} = 10^{(-2.73780 + (0.681310 * \log_{10}(\text{MTOM})) + (-0.0277861 * (\log_{10}(\text{MTOM}))^2))}$$

- b) For aeroplanes specified in 2.1.1 a) and c) with a maximum take-off mass greater than 60 000 kg, and less than or equal to 70 395 kg:

$$\text{Maximum permitted value} = 0.764$$

- c) For aeroplanes specified in 2.1.1 a) and c) with a maximum take-off mass of greater than 70 395 kg:

$$\text{Maximum permitted value} = 10^{(-1.412742 + (-0.020517 * \log_{10}(\text{MTOM})) + (0.0593831 * (\log_{10}(\text{MTOM}))^2))}$$

- d) For aeroplanes specified in 2.1.1 d), e), f) and g) with a maximum certificated take-off mass less than or equal to 60 000 kg:

$$\text{Maximum permitted value} = 10^{(-2.57535 + (0.609766 * \log_{10}(\text{MTOM})) + (-0.0191302 * (\log_{10}(\text{MTOM}))^2))}$$

- e) For aeroplanes specified in 2.1.1 d), e), f) and g) with a maximum certificated take-off mass greater than 60 000 kg, and less than or equal to 70 107 kg:

$$\text{Maximum permitted value} = 0.797$$

- f) For aeroplanes specified in 2.1.1 d), e), f) and g) with a maximum take-off mass of greater than 70 107 kg:

$$\text{Maximum permitted value} = 10^{(-1.39353 + (-0.020517 * \log_{10}(\text{MTOM})) + (0.0593831 * (\log_{10}(\text{MTOM}))^2))}$$

2.5 Reference conditions for determining aeroplane specific air range

2.5.1 The reference conditions shall consist of the following conditions within the approved normal operating envelope of the aeroplane:

- a) the aeroplane gross masses defined in 2.3;
- b) a combination of altitude and airspeed selected by the applicant for each of the specified reference aeroplane gross masses;

Note.— These conditions are generally expected to be the combination of altitude and airspeed that results in the highest SAR value, which is usually at the maximum range cruise Mach number at the optimum altitude. The selection of conditions other than optimum conditions will be to the detriment of the applicant because the SAR value will be adversely affected.

- c) steady (un-accelerated), straight, and level flight;
- d) aeroplane in longitudinal and lateral trim;
- e) ICAO standard day atmosphere¹;
- f) gravitational acceleration for the aeroplane travelling in the direction of true North in still air at the reference altitude and a geodetic latitude of 45.5 degrees, based on g_0 ;
- g) fuel lower heating value equal to 43.217 MJ/kg (18 580 BTU/lb);
- h) a reference aeroplane CG position selected by the applicant to be representative of a mid-CG point relevant to design cruise performance at each of the three reference aeroplane masses;

Note.— For an aeroplane equipped with a longitudinal CG control system, the reference CG position may be selected to take advantage of this feature.

- i) a wing structural loading condition selected by the applicant for representative operations conducted in accordance with the aeroplane's payload capability and manufacturer standard fuel management practices;
- j) applicant selected electrical and mechanical power extraction and bleed flow relevant to design cruise performance and in accordance with manufacturer recommended procedures;

Note.— Power extraction and bleed flow due to the use of optional equipment such as passenger entertainment systems need not be included.

- k) engine handling/stability bleeds operating according to the nominal design of the engine performance model for the specified conditions; and
- l) engine deterioration level selected by the applicant to be representative of the initial deterioration level (a minimum of 15 take-offs or 50 engine flight hours).

2.5.2 If the test conditions are not the same as the reference conditions, then corrections for the differences between test and reference conditions shall be applied as described in Appendix 1.

¹ ICAO Doc 7488/3 entitled "Manual of the ICAO Standard Atmosphere".

2.6 Test procedures

2.6.1 The SAR values that form the basis of the CO₂ emissions evaluation metric value shall be established either directly from flight tests or from a performance model validated by flight tests.

2.6.2 The test aeroplane shall be representative of the configuration for which certification is requested.

2.6.3 The test and analysis procedures shall be conducted in an approved manner to yield the CO₂ emissions evaluation metric value, as described in Appendix 1. These procedures shall address the entire flight test and data analysis process, from pre-flight actions to post-flight data analysis.

Note.— The fuel used for each flight test should meet the specification defined in either ASTM D1655-15², DEF STAN 91-91 Issue 7, Amendment 3³ or equivalent.

² ASTM D1655-15 entitled “Standard Specification for Aviation Turbine Fuels”.

³ Defence Standard 91-91, Issue 7, Amendment 3, entitled “Turbine Fuel, Kerosene Type, Jet A-1”.

APPENDIX 1. DETERMINATION OF THE AEROPLANE CO₂ EMISSIONS EVALUATION METRIC VALUE

1.— SUBSONIC JET AEROPLANES OVER 5 700 kg

2.— PROPELLER-DRIVEN AEROPLANES OVER 8 618 kg

1. INTRODUCTION

The process for determining the CO₂ emissions evaluation metric value includes:

- a) the determination of the reference geometric factor (see Appendix 2);
- b) the determination of the certification test and measurement conditions and procedures for the determination of SAR (see Section 3), either by direct flight test or by way of a validated performance model, including:
 - 1) the measurement of parameters needed to determine SAR (see Section 4);
 - 2) the correction of measured data to reference conditions for SAR (see Section 5); and
 - 3) the validation of data for calculation of the certified CO₂ emissions evaluation metric value (see Section 6);
- c) calculation of the CO₂ emissions evaluation metric value (see Section 7); and
- d) reporting of data to the certificating authority (see Section 8).

Note.— The instructions and procedures ensure uniformity of compliance tests, and permit comparison between various types of aeroplanes.

2. METHODS FOR DETERMINING SPECIFIC AIR RANGE

2.1 Specific air range may be determined by either direct flight test measurement of SAR test points, including any corrections of test data to reference conditions, or by the use of a performance model approved by the certificating authority. A performance model, if used, shall be validated by actual SAR flight test data.

2.2 In either case the SAR flight test data shall be acquired in accordance with the procedures defined in this Standard and approved by the certificating authority.

Note.— Validation of the performance model need only be shown for the test points and conditions relevant to showing compliance with the standard. Test and analysis methods, including any algorithms that may be used, should be described in sufficient detail.

3. SPECIFIC AIR RANGE CERTIFICATION TEST AND MEASUREMENT CONDITIONS

3.1 General

This section prescribes the conditions under which SAR certification tests shall be conducted and the measurement procedures that shall be used.

Note.— Many applications for certification of a CO₂ emissions metric value involve only minor changes to the aeroplane type design. The resultant changes in the CO₂ emissions metric value can often be established reliably by way of equivalent procedures without the necessity of resorting to a complete test.

3.2 Flight test procedure

3.2.1 Pre-flight

The pre-flight procedure shall be approved by the certifying authority and shall include the following elements:

- a) **Aeroplane conformity.** The test aeroplane shall be confirmed to be in conformance with the type design configuration for which certification is sought.
- b) **Aeroplane weighing.** The test aeroplane shall be weighed. Any change in mass after the weighing and prior to the test flight shall be accounted for.
- c) **Fuel lower heating value.** A sample of fuel shall be taken for each flight test to determine its lower heating value. Fuel sample test results shall be used for the correction of measured data to reference conditions. The determination of lower heating value and the correction to reference conditions shall be subject to the approval of the certifying authority.
 - 1) **Recommendation.**— *The fuel lower heating value should be determined in accordance with methods which are at least as stringent as those defined in ASTM specification D4809-13⁴.*
 - 2) **Recommendation.**— *The fuel sample should be representative of the fuel used for each flight test and should not be subject to errors or variations due to fuel being uplifted from multiple sources, fuel tank selection or fuel layering in a tank.*
- d) **Fuel specific gravity and viscosity.** A sample of fuel shall be taken for each flight test to determine its specific gravity and viscosity when volumetric fuel-flow meters are used.

Note.— When using volumetric fuel-flow meters the fuel viscosity is used to determine the volumetric fuel flow from the parameters measured by a volumetric fuel flow meter. The fuel specific gravity (or density) is used to convert the volumetric fuel flow to a mass fuel flow.

- 1) **Recommendation.** — *The fuel specific gravity should be determined in accordance with methods which are at least as stringent as those defined in ASTM specification D4052-11⁵.*
- 2) **Recommendation.**— *The fuel kinematic viscosity should be determined in accordance with methods which are at least as stringent as those defined in ASTM specification D445-15⁶.*

⁴ ASTM D4809-13 entitled “Standard Test Method for Heat of Combustion of Liquid Hydrocarbon Fuels by Bomb Calorimeter (Precision Method)”.

⁵ ASTM D4052-11 entitled “Standard Test Method for Density and Relative Density of Liquids by Digital Density Meter”.

⁶ ASTM D445-15 entitled “Standard Test Method for Kinematic Viscosity of Transparent and Opaque Liquids (and Calculation of Dynamic Viscosity)”.

3.2.2 Flight test method

3.2.2.1 The flight tests shall be performed in accordance with the following flight test method and the stability conditions described in 3.2.3.

3.2.2.2 Test points shall be separated by a minimum duration of two minutes, or separated by an exceedance of one or more of the stability criteria limits in 3.2.3.1.

3.2.2.3 **Recommendation.**— *During the test conditions flown to determine SAR the following criteria should be adhered to:*

- a) *the aeroplane is flown at constant pressure altitude and constant heading along isobars to the extent that is practicable;*
- b) *the engine thrust/power setting is stable for un-accelerated level flight;*
- c) *the aeroplane is flown as close as practicable to the reference conditions to minimize the magnitude of any corrections;*
- d) *there are no changes in trim or engine power/thrust settings, engine stability and handling bleeds, and electrical and mechanical power extraction (including bleed flow). Any changes in the use of aeroplane systems that may affect the SAR measurement should be avoided; and*
- e) *movement of on-board personnel is kept to a minimum.*

3.2.3 Test condition stability

3.2.3.1 For a SAR measurement to be valid, the following parameters shall be maintained within the indicated tolerances for a minimum duration of 1 minute during which the SAR data is acquired:

- a) Mach number within ± 0.005 ;
- b) ambient temperature within $\pm 1^\circ\text{C}$;
- c) heading within ± 3 degrees;
- d) track within ± 3 degrees;
- e) drift angle less than 3 degrees;
- f) ground speed within ± 3.7 km/h (± 2 kt);
- g) difference in ground speed at the beginning of the test condition from the ground speed at the end of the test condition within ± 2.8 km/h/min (± 1.5 kt/min); and
- h) pressure altitude within ± 23 m (± 75 ft).

3.2.3.2 Alternatives to the stable test condition criteria listed above may be used provided that stability can be sufficiently demonstrated to the certifying authority.

3.2.3.3 Test points that do not meet the stable test criteria defined in 3.2.3.1 should normally be discarded. However, test points that do not meet the stability criteria of 3.2.3.1 may be acceptable subject to the approval of the certifying authority, and would be considered as an equivalent procedure.

3.2.4 Verification of aeroplane mass at test conditions

3.2.4.1 The procedure for determining the mass of the aeroplane at each test condition shall be subject to the approval of the certificating authority.

3.2.4.2 **Recommendation.**— *The mass of the aeroplane during a flight test should be determined by subtracting the fuel used (i.e. integrated fuel flow) from the mass of the aeroplane at the start of the test flight. The accuracy of the determination of the fuel used should be verified by weighing the test aeroplane on calibrated scales either before and after the SAR test flight, or before and after another test flight with a cruise segment provided that flight occurs within one week or 50 flight hours (at the option of the applicant) of the SAR test flight and with the same, unaltered fuel flow meters.*

4. MEASUREMENT OF AEROPLANE SPECIFIC AIR RANGE

4.1 Measurement System

4.1.1 The following parameters shall be recorded at a minimum sampling rate of 1 Hz:

- a) airspeed;
- b) ground speed;
- c) true airspeed;
- d) fuel flow;
- e) engine power setting parameter (e.g. fan speed, engine pressure ratio, torque, shaft horse power);
- f) pressure altitude;
- g) temperature;
- h) heading;
- i) track; and
- j) fuel used (for the determination of gross mass and CG position).

4.1.2 The following parameters shall be recorded at a suitable sampling rate:

- a) latitude;
- b) engine bleed positions and power off-takes; and
- c) power extraction (electrical and mechanical load).

4.1.3 The value of each parameter used for the determination of SAR, except for ground speed, shall be the simple arithmetic average of the measured values for that parameter obtained throughout the stable test condition (see 3.2.3.1).

Note.— The rate of change of ground speed during the test condition is to be used to evaluate and correct any acceleration or deceleration that might occur during the test condition.

4.1.4 The resolution of the individual measurement devices shall be sufficient to determine that the stability of the parameters defined in 3.2.3.1 is maintained.

4.1.5 The overall SAR measurement system is considered to be the combination of instruments and devices, including any associated procedures, used to acquire the following parameters necessary for the determination of SAR:

- a) fuel flow;
- b) Mach number;
- c) altitude;
- d) aeroplane mass;
- e) ground speed;
- f) outside air temperature;
- g) fuel lower heating value; and
- h) centre of gravity

4.1.6 The accuracy of the individual elements that comprise the overall SAR measurement system is defined in terms of its effect upon SAR. The cumulative error associated with the overall SAR measurement system is defined as the root sum of squares (RSS) of the individual accuracies.

Note.— Parameter accuracy need only be examined within the range of the parameter needed for showing compliance with the CO₂ emissions standard.

4.1.7 If the absolute value of the cumulative error of the overall SAR measurement system is greater than 1.5 per cent a penalty equal to the amount that the RSS value exceeds 1.5 per cent shall be applied to the SAR value corrected to reference conditions (see section 5). If the absolute value of the cumulative error of the overall SAR measurement system is less than or equal to 1.5 per cent no penalty shall be applied.

5. CALCULATION OF REFERENCE SPECIFIC AIR RANGE FROM MEASURED DATA

5.1 Calculation of SAR

5.1.1 SAR is calculated from the following equation:

$$\text{SAR} = \text{TAS}/W_f$$

where:

TAS is the true air speed; and

W_f is total aeroplane fuel flow.

5.2 Corrections from test to reference conditions

5.2.1 Corrections shall be applied to the measured SAR values to correct to the reference conditions specified in 2.5 of Part II, Chapter 2. Corrections shall be applied for each of the following measured parameters that is not at the reference conditions:

Apparent gravity. Acceleration, caused by the local effect of gravity, and inertia, affects the test weight of the aeroplane. The apparent gravity at the test conditions varies with latitude, altitude, ground speed, and direction of motion relative to the Earth's axis. The reference gravitational acceleration is the gravitational acceleration for the aeroplane travelling in the direction of true North in still air at the reference altitude, a geodetic latitude of 45.5 degrees, and based on g_0 .

Mass/ δ . The lift coefficient of the aeroplane is a function of mass/ δ and Mach number, where δ is the ratio of the atmospheric pressure at a given altitude to the atmospheric pressure at sea level. The lift coefficient for the test condition affects the drag of the aeroplane. The reference mass/ δ is derived from the combination of the reference mass, reference altitude and atmospheric pressures determined from the ICAO standard atmosphere.

Acceleration/deceleration (energy). Drag determination is based on an assumption of steady, unaccelerated flight. Acceleration or deceleration occurring during a test condition affects the assessed drag level. The reference condition is steady, unaccelerated flight.

Reynolds number. The Reynolds number affects aeroplane drag. For a given test condition the Reynolds number is a function of the density and viscosity of air at the test altitude and temperature. The reference Reynolds number is derived from the density and viscosity of air from the ICAO standard atmosphere at the reference altitude and temperature.

CG position. The position of the aeroplane centre of gravity affects the drag due to longitudinal trim.

Aeroelastics. Wing aeroelasticity may cause a variation in drag as a function of aeroplane wing mass distribution. Aeroplane wing mass distribution will be affected by the fuel load distribution in the wings and the presence of any external stores.

Fuel lower heating value. The fuel lower heating value defines the energy content of the fuel. The lower heating value directly affects the fuel flow at a given test condition.

Altitude. The altitude at which the aeroplane is flown affects the fuel flow.

Temperature. The ambient temperature affects the fuel flow. The reference temperature is the standard day temperature from the ICAO standard atmosphere at the reference altitude.

Engine deterioration level. When first used, engines undergo a rapid, initial deterioration in fuel efficiency. Thereafter, the rate of deterioration significantly decreases. Engines with less deterioration than the reference engine deterioration level may be used, subject to the approval of the certificating authority. In such a case, the fuel flow shall be corrected to the reference engine deterioration level using an approved method. Engines with more deterioration than the reference engine deterioration level may be used. In this case a correction to the reference condition shall not be permitted.

Electrical and mechanical power extraction and bleed flow. Electrical and mechanical power extraction and bleed flow affects the fuel flow.

Note.— Post-flight data analysis includes the correction of measured data for data acquisition hardware response characteristics (e.g. system latency, lag, offset, buffering, etc.).

5.2.2 Correction methods are subject to the approval of the certificating authority. If the applicant considers that a particular correction is unnecessary then acceptable justification shall be provided to the certificating authority.

5.3 Calculation of specific air range

5.3.1 The SAR values for each of the three reference masses defined in 2.3 of Chapter 2, Part II, shall be calculated either directly from the measurements taken at each valid test point adjusted to reference conditions, or indirectly from a performance model that has been validated by the test points. The final SAR value for each reference mass shall be the simple arithmetic average of all valid test points at the appropriate gross mass, or derived from a validated performance model. No data acquired from a valid test point shall be omitted unless agreed by the certificating authority.

Note.— Extrapolations consistent with accepted airworthiness practices to masses other than those tested may be allowable using a validated performance model. The performance model should be based on data covering an adequate range of lift coefficient, Mach number, and thrust specific fuel consumption such that there is no extrapolation of these parameters.

6. VALIDITY OF RESULTS

6.1 The 90 per cent confidence interval shall be calculated for each of the SAR values at the three reference masses.

6.2 If clustered data is acquired independently for each of the three gross mass reference points, the minimum sample size acceptable for each of the three gross mass SAR values shall be six.

6.3 Alternatively SAR data may be collected over a range of masses. In this case the minimum sample size shall be twelve and the 90 per cent confidence interval shall be calculated for the mean regression line through the data.

6.4 If the 90 per cent confidence interval of the SAR value at any of the three reference aeroplane masses exceeds ± 1.5 per cent, the SAR value at that reference mass may be used, subject to the approval of the certificating authority, if a penalty is applied to it. The penalty shall be equal to the amount that the 90 per cent confidence interval exceeds ± 1.5 per cent. If the 90 per cent confidence interval of the SAR value is less than or equal to ± 1.5 per cent no penalty need be applied.

Note.— Methods for calculating the 90 per cent confidence interval are given in ICAO Doc 9501 Volume III.

7. CALCULATION OF THE CO₂ EMISSIONS EVALUATION METRIC VALUE

7.1 The CO₂ emissions evaluation metric value shall be calculated according to the formula defined in 2.2 of Part II, Chapter 2.

8. REPORTING OF DATA TO THE CERTIFICATING AUTHORITY

Note.— The information required is divided into: 1) general information to identify the aeroplane characteristics and the method of data analysis; 2) list of reference conditions used; 3) the data obtained from the aeroplane test(s); 4) the calculations and corrections of SAR test data to reference conditions, and 5) the results derived from the test data.

8.1 General information

The following information shall be provided for each aeroplane type and model for which CO₂ certification is sought:

- a) designation of the aeroplane type and model;
- b) general characteristics of the aeroplane, including centre of gravity range, number and type designation of engines and, if fitted, propellers;
- c) maximum take-off mass;
- d) the relevant dimensions needed for calculation of the reference geometric factor; and
- e) serial number(s) of the aeroplane(s) tested for CO₂ certification purposes and, in addition, any modifications or non-standard equipment likely to affect the CO₂ characteristics of the aeroplane.

8.2 Reference conditions

The reference conditions used for the determination of specific air range (see Part II, Chapter 2, 2.5) shall be provided.

8.3 Test data

The following measured test data, including any corrections for instrumentation characteristics, shall be provided for each of the test measurement points.

- a) airspeed, ground speed and true airspeed;
- b) fuel flow;
- c) pressure altitude;
- d) static air temperature;
- e) aeroplane gross mass and centre of gravity for each test point;
- f) levels of electrical and mechanical power extraction and bleed flow;
- g) engine performance;

- 1) for jet aeroplanes, engine power setting;
- 2) for propeller-driven aeroplanes, shaft horsepower or engine torque and propeller rotational speed.
- h) fuel lower heating value;
- i) fuel specific gravity and kinematic viscosity if volumetric fuel flow meters are used (see 3.2.1d);
- j) the cumulative error (RSS) of the overall measurement system (see 4.1.6);
- k) heading, track and latitude;
- l) stability criteria (see 3.2.3.1);
- m) description of the instruments and devices used to acquire the parameters necessary for the determination of SAR, and their individual accuracies in terms of their effect on SAR (see 4.1.5 and 4.1.6);

8.4 Calculations and corrections of SAR test data to reference conditions

The measured SAR values, corrections to the reference conditions, and corrected SAR values shall be provided for each of the test measurement points.

8.5 Derived data

The following derived information shall be provided for each aeroplane tested for certification purposes:

- a) the specific air range (km/kg) for each reference aeroplane mass and the associated 90 per cent confidence interval;
- b) the average of the inverse of the three reference mass specific air range values;
- c) the reference geometric factor ; and
- d) the CO₂ emissions evaluation metric value.

APPENDIX 2. REFERENCE GEOMETRIC FACTOR

1. The reference geometric factor (RGF) is a non-dimensional parameter used to adjust $(1/SAR)_{AVG}$. RGF is based on a measure of fuselage size normalised with respect to 1 m^2 , and is derived as follows:
 - a) for aeroplanes with a single deck determine the area of a surface (expressed in m^2) bounded by the maximum width of the fuselage outer mould line (OML) projected to a flat plane parallel with the main deck floor; and
 - b) for aeroplanes with an upper deck determine the sum of the area of a surface (expressed in m^2) bounded by the maximum width of the fuselage outer mould line (OML) projected to a flat plane parallel with the main deck floor, and the area of a surface bounded by the maximum width of the fuselage OML at or above the upper deck floor projected to a flat plane parallel with the upper deck floor is determined; and
 - c) determine the non-dimensional RGF by dividing the areas defined in 1(a) or 1(b) by 1 m^2 .
2. The RGF includes all pressurised space on the main or upper deck including aisles, assist spaces, passage ways, stairwells and areas that can accept cargo and auxiliary fuel containers. It does not include permanent integrated fuel tanks within the cabin or any unpressurized fairings, nor crew rest/work areas or cargo areas that are not on the main or upper deck (e.g. 'loft' or under floor areas). RGF does not include the cockpit crew zone.
3. The aft boundary to be used for calculating RGF is the aft pressure bulkhead. The forward boundary is the forward pressure bulkhead except for the cockpit crew zone.
4. Areas that are accessible to both crew and passengers are excluded from the definition of the cockpit crew zone. For aeroplanes with a cockpit door, the aft boundary of the cockpit crew zone is the plane of the cockpit door. For aeroplanes having optional interior configurations that include different locations of the cockpit door, or no cockpit door, the boundary shall be determined by the configuration that provides the smallest cockpit crew zone. For aeroplanes certified for single-pilot operation, the cockpit crew zone shall extend half the width of the cockpit.
5. Figures A2-1 and A2-2 provide a notional view of the RGF boundary conditions.

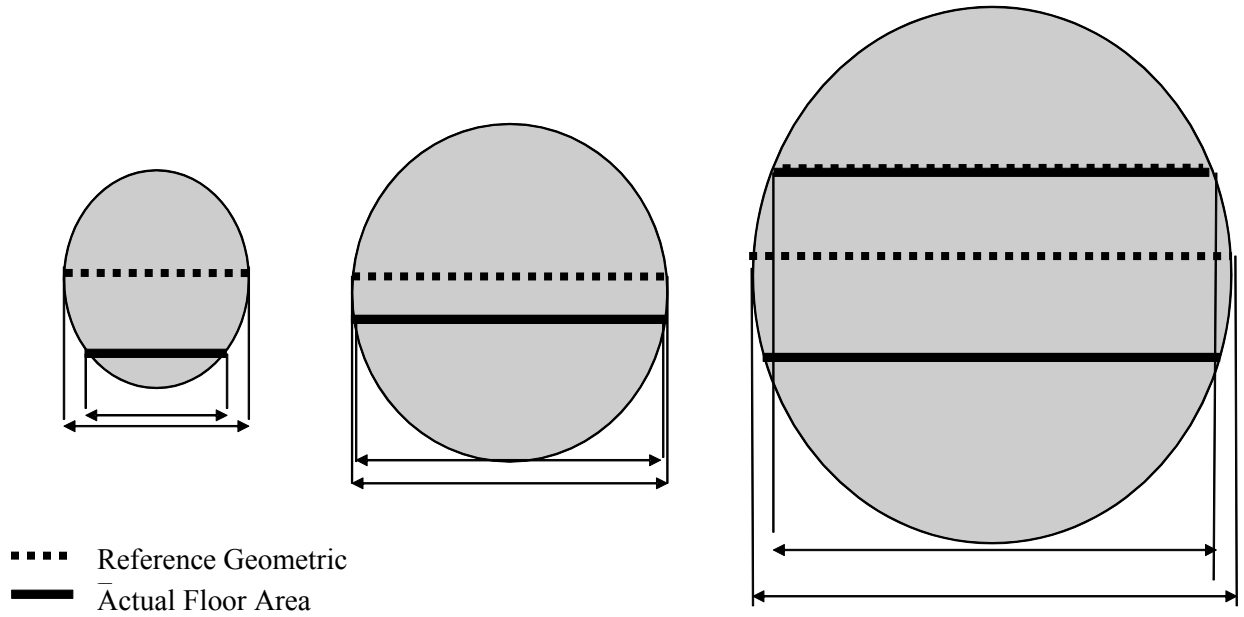

Figure A2-1. Cross-sectional View

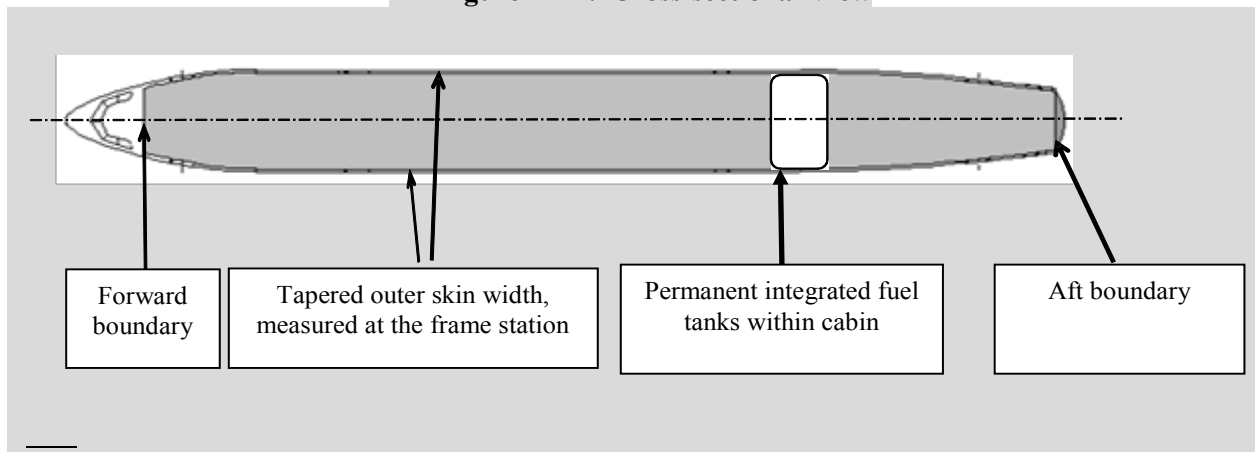

Figure A2-2. Longitudinal View

APPENDIX B
(English only)

Environmental Technical Manual

Volume III

Procedures for the CO₂ Emissions Certification of Aeroplanes

**International Civil Aviation Organization
Committee on Aviation Environmental Protection**

FOREWORD

ICAO Doc 9501, Volume III, First Edition, includes material which has been approved by the ICAO Committee on Aviation Environmental Protection (CAEP) during their tenth meeting (CAEP/10) in February 2016. This manual is to be periodically revised under the supervision of the CAEP Steering Group and is intended to make the most recent information available to certificating authorities, aeroplane certification applicants and other interested parties in a timely manner, aiming at achieving the highest degree of harmonisation possible. The technical procedures and equivalent procedures described in this approved revision of the ETM Volume III are consistent with currently accepted techniques and modern instrumentation. This revision and subsequent revisions that may be approved by the CAEP Steering Group will be posted on the ICAO website (<http://www.icao.int/>) under “publications” until the latest approved revision is submitted to CAEP for formal endorsement and subsequent publication by ICAO.

Comments on this manual, particularly with respect to its application and usefulness, would be appreciated from all States. These comments will be taken into account in the preparation of subsequent editions. Comments concerning this manual should be addressed to:

The Secretary General
International Civil Aviation Organization
999 Robert-Bourassa Boulevard
Montréal, Quebec H3C 5H7
Canada

TABLE OF CONTENTS

<u>FOREWORD</u>	2
<u>TABLE OF CONTENTS</u>	3
<u>ACRONYMS AND ABBREVIATIONS</u>	5
<u>CHAPTER 1 – INTRODUCTION</u>	6
<u>1.1</u> <u>PURPOSE</u>	6
<u>1.2</u> <u>DOCUMENT STRUCTURE</u>	6
<u>1.3</u> <u>EQUIVALENT PROCEDURES</u>	6
<u>1.4</u> <u>EXPLANATORY INFORMATION</u>	6
<u>1.5</u> <u>CONVERSION OF UNITS</u>	7
<u>1.6</u> <u>REFERENCES</u>	7
<u>CHAPTER 2 - GENERAL GUIDELINES</u>	8
<u>2.1</u> <u>APPLICABILITY OF ANNEX 16, VOLUME III</u>	8
2.1.4 Type design configurations which shall be certified	8
2.1.5 Appropriate margin to regulatory level	10
<u>2.2</u> <u>CHANGES TO CO₂ APPROVED AEROPLANE TYPE DESIGNS</u>	10
<u>2.3</u> <u>CO₂ EMISSIONS EVALUATION METRIC COMPLIANCE DEMONSTRATION PLANS</u>	11
<u>2.4</u> <u>ENGINE INTERMIX</u>	12
<u>2.5</u> <u>EXEMPTIONS</u>	12
<u>CHAPTER 3 - SAR DETERMINATION PROCEDURES</u>	16
<u>3.1</u> <u>SAR MEASUREMENT PROCEDURES</u>	16
3.1.1 FLIGHT TEST PROCEDURES	16
<u>3.2</u> <u>SAR DATA ANALYSIS</u>	17
3.2.1 DATA SELECTION	17
3.2.2 CORRECTIONS TO REFERENCE CONDITIONS	20
<u>3.3</u> <u>VALIDITY OF RESULTS - CONFIDENCE INTERVAL</u>	30
3.3.1 INTRODUCTION	30
3.3.2 DIRECT FLIGHT TESTING	30
3.3.3 REGRESSION MODEL	30
3.3.4 WORKED EXAMPLES OF THE DETERMINATION OF 90 PER CENT CONFIDENCE INTERVALS	34
<u>3.4</u> <u>EQUIVALENT PROCEDURES</u>	50
3.4.1 APPROVAL BASED ON EXISTING DATA	50

[3.4.2 APPROVAL BASED ON BACK-TO-BACK TESTING](#) 50

[3.4.3 APPROVAL OF CHANGES BASED ON ANALYSIS](#) 50

[APPENDIX 1 - REFERENCES](#)51

[APPENDIX 2 - BIBLIOGRAPHY](#)52

ACRONYMS AND ABBREVIATIONS

Acronym or Abbreviation	Meaning	Unit
A	Area	m ²
A16V3	Annex 16 Volume III	-
C _D	Drag coefficient	-
C _L	Lift coefficient	-
CG	Centre of gravity	-
CI	Confidence interval	-
CO ₂	Carbon dioxide	-
ETMV3	Environmental technical manual volume III	-
g	Gravitational acceleration	m/s ²
h	Altitude	m
LHV	Lower heating value	MJ/kg
M	Mach number	-
MAC	Mean aerodynamic chord	cm
MTOM	Maximum take-off mass	kg
OML	Outer mould line	-
R _e	Radius of the Earth	m
RE	Reynolds number	-
RGF	Reference geometric factor	-
SAR	Specific air range	km/kg
T	Temperature	K
TAS	True air speed	km/h
TOM	Take-off mass	kg
V	Speed	m/s
W _f	Total aeroplane fuel flow	kg/h
W	Weight	N
WV	Weight variant	-
δ	Ratio of atmospheric pressure at a given altitude to the atmospheric pressure at sea level	-
Φ	Latitude	degrees
ρ	Density	kg/m ³
σ	Ground track angle	degrees

Chapter 1 – INTRODUCTION

1.1 PURPOSE

1.1.1 The aim of this manual is to promote uniformity of implementation of the technical procedures of Annex 16 — Environmental Protection, Volume III — Aeroplane CO₂ Emissions by providing: (1) guidance to certificating authorities, applicants and other interested parties regarding the intended meaning of the Standards in the current edition of the Annex; (2) guidance on specific methods that are deemed acceptable in demonstrating compliance with those Standards; and (3) equivalent procedures resulting in effectively the same CO₂ emissions evaluation metric that may be used in lieu of the procedures specified in the Appendices of Annex 16 Volume III.

1.2 DOCUMENT STRUCTURE

1.2.1 Chapter 1 provides general information regarding the use of this Environmental Technical Manual Volume III. Chapter 2 provides general guidelines on the interpretation of Annex 16 Volume III. Chapter 3 brings technical guidelines for the certification of aeroplanes against Annex 16 Volume III, including equivalent procedures.

1.2.2 Guidance is provided in the form of explanatory information, acceptable methods for showing compliance, and equivalent procedures.

1.3 EQUIVALENT PROCEDURES

1.3.1 The procedures described in the Annex, as supplemented by the means of compliance information provided in this manual, shall be used unless an equivalent procedure is approved by the certificating authority. Equivalent procedures should not be considered as limited only to those described herein, as this manual will be expanded as new equivalent procedures are developed. Also, their presentation does not infer limitation of their application or commitment by certificating authorities to their further use.

1.3.2 The use of equivalent procedures may be requested by applicants for many reasons, including:

- 1) to make use of previously acquired or existing data for the aeroplane; and
- 2) to minimize the costs of demonstrating compliance with the requirements of Annex 16, Volume III, by keeping aeroplane test time and equipment and personnel costs to a minimum.

1.4 EXPLANATORY INFORMATION

1.4.1 Explanatory information has the following purpose:

- a) explains the intent of the Annex 16 Volume III Standards;
- b) states current policies of certificating authorities regarding compliance with the Annex; and

c) provides information on critical issues concerning approval of applicants' compliance methodology proposals.

1.5 CONVERSION OF UNITS

1.5.1 Conversions of some non-critical numerical values between U.S. Customary (English) and SI units are shown in the context of acceptable approximations.

1.6 REFERENCES

1.6.1 Unless otherwise specified, references throughout this document to "the Annex" relate to Annex 16 to the Convention on International Civil Aviation (Environmental Protection), Volume III (Aeroplane CO₂ Emissions), First Edition.

1.6.2 References to sections of this manual are defined only by the section number to which they refer. References to documents other than the Annex are numbered sequentially (e.g., Reference 1, Reference 2, etc.). A list of these documents is provided in Appendix 1 of this manual, and a bibliography can be found in Appendix 2.

Chapter 2 - GENERAL GUIDELINES

2.1 APPLICABILITY OF ANNEX 16, VOLUME III

2.1.1 The Chicago Convention Article 3 specifically states that it is not applicable to state aircraft and provides some examples (see below), but this can also include specific flights carrying official government representatives:

“ a) This Convention shall be applicable only to civil aircraft, and shall not be applicable to state aircraft.

b) Aircraft used in military, customs and police services shall be deemed to be state aircraft.”

2.1.2 In addition, Annex 16 Vol. III, Part II, Chapter 2, para. 2.1 excepts amphibious aeroplanes; aeroplanes initially designed or modified for specialized operational requirements and used as such; aeroplanes designed with zero RGF; and those aeroplanes specifically designed or modified and used for fire-fighting purposes. These are typically special categories of aeroplanes which are limited in numbers and have specific technical characteristics resulting in very different CO₂ metric values compared to all other aeroplane types in the proposed applicability scope.

2.1.3 Examples of specialized operational requirements include:

- a) aeroplanes that are initially certified as civil aeroplanes during the production process but immediately converted to military aeroplanes;
- b) a required capacity to carry cargo that is not possible by using less-specialised aeroplanes;
- c) a required capacity for very short or vertical take-offs and landings;
- d) a required capacity to conduct scientific, research, or humanitarian missions exclusive of commercial service; or
- e) similar factors.

2.1.4 Type design configurations which shall be certified

2.1.4.1 Annex 16 Volume III defines in Part I, Chapter 1 the “*Maximum take-off mass*” (MTOM) as being “*the highest of all take-off masses for the type design configuration*”. Part II, Chapter 2, section 2.3 defines the three reference masses at which the 1/SAR value shall be established, and these masses are calculated based on the MTOM.

2.1.4.2 Applicants may develop multiple TOM variants of a specific type design configuration (i.e., combination of airframe/engine) for operational purposes. As stated above, only the highest Maximum Take-off Mass of a specific airframe/engine combination is required to be certified against Annex 16 Volume III. As stated in Annex 16, Volume III, Part II, Chapter II, paragraph 2.3.2, certification at MTOM also certifies all TOM variants. These TOM variants would have the same CO₂ emissions evaluation metric value as the MTOM.

2.1.4.3 Annex 16, Volume III, Part II, Chapter II, paragraph 2.3.2, also states that *“The applicant may also apply for the approval of CO₂ metric values at take-off masses lower than the highest of all maximum take-off masses”*. The purpose of this statement is to allow the applicant to apply for approval of a separate CO₂ emissions evaluation metric value for a TOM lower than the MTOM. In that case, the reference aeroplane masses, and the maximum permitted CO₂ emissions evaluation metric value, would be based on the TOM instead of the MTOM. The CO₂ emissions evaluation metric value for this TOM could then also be used for any TOM variant of even lower mass. Applicants can apply for approval for separate CO₂ emissions evaluation metric values for as many or as few TOM variants as they desire.

2.1.4.4 Example of type design configurations to be certified.

Assuming an applicant applies for the approval of the following type design configurations:

- a) Two fuselage lengths: Model A and Model B;
- b) Two engine options: Engine X and Engine Y;
- c) Two weight variants (WV) for each fuselage length: WV01 and WV02 for Model A and WV11 and WV12 for Model B.

The possible combinations are summarised in Table 2.1-1 below:

Model A	Engine X	WV01
		WV02
	Engine Y	WV01
		WV02
Model B	Engine X	WV11
		WV12
	Engine Y	WV11
		WV12

Table 2.1-1 - Type Design Configuration combinations

The type design configurations that shall be certified against Annex 16 Volume III are the ones that have the highest MTOM. Each combination of fuselage length and engine option is a separate type design configuration. Assuming WV01 and WV11 have higher maximum take-off masses than WV02 and WV12, the following combinations shall be certified:

- a) Model A – Engine X – WV01;
- b) Model A – Engine Y – WV01;
- c) Model B – Engine X – WV11;
- d) Model B – Engine Y – WV11.

The combinations with WV02 and WV12 would be assigned the same CO₂ emissions evaluation metric value as the combinations with WV01 and WV11, respectively. At the applicant’s option, the combinations with WV02 and/or WV12 could also be certified to obtain a different CO₂ emissions evaluation metric value for those combinations.

2.1.5 Appropriate margin to regulatory level

2.1.5.1 If an applicant chooses to voluntarily certify a lower TOM variant, as discussed in paragraph 2.1.4 above, it should be kept in mind that an underlying principle in applying the CO₂ standard is that the highest weight variant (MTOM) has the lowest margin to the regulatory limit level. The 1/SAR value used in the CO₂ metric system is calculated as an average of three reference masses (high, medium, and low).

2.1.5.2 In establishing the reference conditions for SAR determination, it is expected that the highest SAR value will be sought at the maximum range cruise condition at the optimum altitude (Annex 16, Volume III, Chapter 2, Paragraph 2.5). It is noted that a greater non-linearity in the 1/SAR vs. mass relationship could be introduced by a constraint unrelated to the aerodynamic and propulsive efficiency of the aeroplane (e.g., an altitude pressurisation limitation). In this instance, particular care should be taken that the principle of the highest weight variant having the lowest margin to the regulatory limit level continues to hold.

2.2 CHANGES TO CO₂ APPROVED AEROPLANE TYPE DESIGNS

2.2.1 Part I, Chapter I includes the following definition:

“Derived version of a CO₂-certified aeroplane. An aeroplane which incorporates changes in type design that either increase its maximum take-off mass, or that increase its CO₂ emissions evaluation metric value by more than:

- a) 1.35% at a maximum take-off mass of 5 700 kg, decreasing linearly to;
- b) 0.75% at a maximum take-off mass of 60 000 kg, decreasing linearly to;
- c) 0.70% at a maximum take-off mass of 600 000 kg; and
- d) a constant 0.70% at maximum take-off masses greater than 600 000 kg.

Note.— Where the certifying authority finds that the proposed change in design, configuration, power or mass is so extensive that a substantially new investigation of compliance with the applicable airworthiness regulations is required, the aeroplane will be considered to be a new type design rather than a derived version.”

2.2.2 Consequently, any change to a CO₂ certified aeroplane type design that increases its maximum take-off mass shall be considered a derived version, and the applicant shall demonstrate compliance with Annex 16 Volume III. In addition, any change to a CO₂ certified aeroplane type design that increases its certified CO₂ emissions evaluation metric value by more than the abovementioned thresholds shall be considered a derived version, and the applicant shall demonstrate compliance with Annex 16 Volume III.

2.2.3 Changes to a CO₂-certified aeroplane type design that do not increase its maximum take-off mass or its CO₂ emissions evaluation metric by more than the abovementioned thresholds are considered no-CO₂ changes, and the CO₂ emissions evaluation metric value of the changed type design configuration shall be

considered the same as the parent type design. This definition of the no-CO₂ change thresholds is also referred to as the “No-CO₂-Change Criterion”.

2.2.4 The evaluation of some changes can be done by simpler equivalent procedures, as detailed in 3.4.2 – Approval based on back-to-back testing or 3.4.3 – Approval of changes based on analysis.

2.2.5 Visualization of the No-CO₂-Change Criterion thresholds is provided in Figure 2.2-1. The trend line equations may be used to evaluate what the no-CO₂ change threshold is for any MTOM.

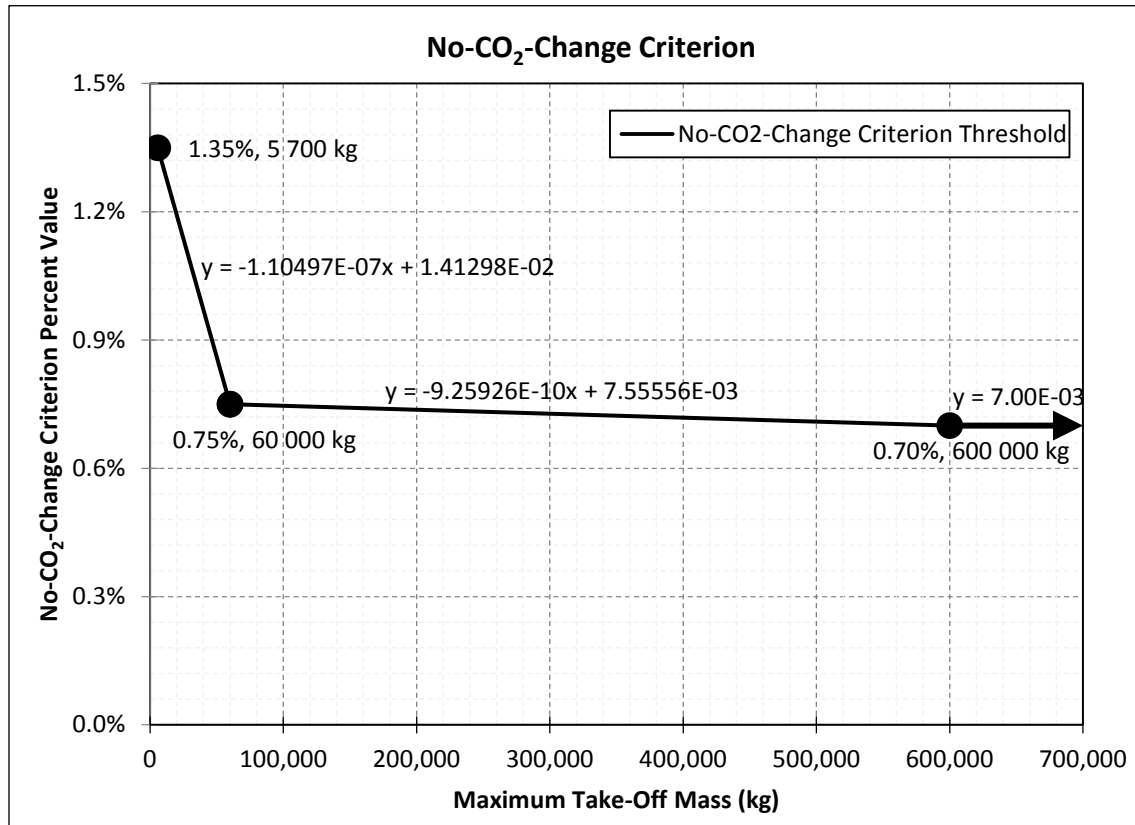

Figure 2.2-1 – Visualization of the No-CO₂-Change Criterion

2.3 CO₂ EMISSIONS EVALUATION METRIC COMPLIANCE DEMONSTRATION PLANS

2.3.1 Prior to undertaking a CO₂ certification demonstration, the applicant should submit to the certifying authority a CO₂ compliance demonstration plan. This plan contains a complete description of the methodology and procedures by which an applicant proposes to demonstrate compliance with the CO₂ certification Standards specified in Annex 16 Volume III. Approval of the plan and the proposed use of any equivalent procedures or technical procedures not included in the Annex remains with the certifying authority. CO₂ compliance demonstration plans should include the following types of information:

- a) *Introduction.* A description of the aeroplane CO₂ certification basis.
- b) *Aeroplane description.* Type, model number and the specific configuration to be certificated.

Note.— The certificating authority should require that the applicant demonstrate and document the conformity of the test aeroplane, particularly with regard to those parts which might affect its CO₂ emissions evaluation metric.

c) *Aeroplane CO₂ certification methodology.* Means of compliance, equivalent procedures from this ETM and technical procedures from Annex 16 Volume III.

d) *Plans for tests.* The plans for test should include:

1) *Test description.* Test methods to comply with the test environment and flight path conditions of the Annex, as appropriate.

Note— Plans for tests shall either be integrated into the basic CO₂ compliance demonstration plan or submitted separately and referenced in the basic plan.

e) *Deliverables.* List the documents that should show compliance with Annex 16 Volume III (test and analysis reports, including RGF determination).

2.4 ENGINE INTERMIX

2.4.1 Applicants will typically demonstrate compliance with the Standard of Chapter 2 of Annex 16 Volume III for an aeroplane type configuration where all engines are of the same design. However an applicant may wish to demonstrate compliance of an aeroplane type configuration where not all the engines are of the same design. Such a configuration is commonly referred to as an “engine intermix” configuration.

2.4.2 In such a case the applicant may, subject to the approval of the certificating authority, demonstrate compliance in one of three ways:

a) In accordance with the test procedures defined in paragraph 2.6 of Chapter 2 of the Annex and for which the test aeroplane shall be representative of the intermix configuration for which certification is requested; or

b) In cases where the CO₂ metric value has been established for aeroplanes on which each of the intermix engine models has been exclusively installed, compliance can be demonstrated on the basis of either:

1) the average of the CO₂ emissions evaluation metrics for aeroplanes on which each of the intermix engine models has been exclusively installed; or

2) the highest CO₂ emissions evaluation metric of the aeroplanes on which each of the intermix engine models has been exclusively installed.

Note.— Paragraph 2.1.2 of Chapter 2 of Annex 16, Volume III, states that in the case of time-limited engine changes Contracting States may not require a demonstration of compliance with the Standards of Annex 16, Volume III.

2.5 EXEMPTIONS

2.5.1 Introduction

2.5.1.1 The current edition of Annex 16, Volume III, contains applicability requirements in Part II, Chapter 2, paragraph 2.1.

2.5.1.2 It is recognized that there may be circumstances where it is justified for certifying authorities to exempt new aeroplane units from the applicability requirements in Annex 16, Volume III, Part II, Chapter 2, paragraph 2.1.1..

2.5.1.3 In order to promote a harmonized global approach to the granting, implementing and monitoring of these exemptions, this section provides guidelines on the process and criteria for issuing exemptions from the CO₂ Standard.

2.5.2 Exemption process

2.5.2.1 Application

The applicant should submit to the competent authority⁷ a formal application letter for the manufacture of the exempted aeroplanes, and copied to all other relevant organizations and involved competent authorities. The letter should include the following information in order for the competent authority to be in a position to review the application:

a) Administration

name, address and contact details of the applicant.

b) Scope of application for exemptions

- 1) aeroplane type (e.g. model designation, type certificate (TC) number, TC date);
- 2) number of aeroplane exemptions requested;
- 3) anticipated duration (end date) of continued production of exempted aeroplanes;
- 4) designation of to whom the aeroplanes will be originally delivered.

c) Justification for the exemptions. In applying for an exemption, an applicant should, to the extent possible, address the following factors, with quantification, in order to support the merits of the exemption request:

- 1) technical issues, from an environmental and airworthiness perspective, which may have delayed compliance;
- 2) economic impacts on the manufacturer, operator(s) and the aviation industry at large;
- 3) environmental effects. This should consider the amount of additional CO₂ that will be emitted as a result of the exemption, including items such as the amount that the aeroplane model exceeds the Standard, taking into account any other aeroplane models in the aeroplane family covered by the same type certificate and their relation to the Standard;
- 4) interdependencies. The impact of changes to reduce CO₂ on other environmental factors, including community noise and NO_x emissions;
- 5) the impact of unforeseen circumstances and hardship due to business circumstances beyond the manufacturer's control (e.g. employee strike, supplier disruption or calamitous event);
- 6) projected future production volumes and plans for producing a compliant version of the aeroplane model for which exemptions are sought;
- 7) equity issues in granting exemptions among economically competing parties (e.g. provide the rationale for granting an exemption when another manufacturer has a compliant aeroplane and does not need an exemption, taking into account the implications for operator fleet composition,

⁷ In most cases this will be the certifying authority although it may vary depending on the processes of individual Member States.

- commonality and related issues in the absence of the aeroplane for which exemptions are sought);
and
8) any other relevant factors.

2.5.2.2 Evaluation Criteria

The evaluation of an exemption application should be based on the justification provided. The total number of exempted aeroplanes should be agreed at the time the application is approved and based on the considerations explained in 2.5.2.1 c).

The number of aeroplanes exempted should be inversely proportional to the % margin of the CO₂ metric value from the regulatory level. Those aeroplane types with a smaller % margin to the regulatory level should be permitted a larger number of exemptions compared to the aeroplane types with a larger % margin.

The maximum number of aeroplanes exempted per type certificate should not exceed those numbers in the tables below.

%Margin to CAEP10 In-Production Regulatory Level	Maximum Exemptions per Annum	Maximum Exemptions	Total
Zero% to A%	x	X	
A% to B%	y	Y	
B% to C%	z	Z	

Note: $x > y > z$ and $X > Y > Z$ and $C > B > A$

% Margin to CAEP10 New Type Regulatory Level	Maximum Exemptions per Annum	Maximum Exemptions	Total
Zero% to a%	r	R	
a% to b%	s	S	
b% to c%	t	T	

Technical Note: % margins and numbers of exemptions in the table above are still to be defined as part of future work.

Exemptions for new aeroplanes should be processed and approved by the competent authority for the production of the exempted aeroplanes in coordination with the competent authorities responsible for the design of the aeroplane and the issuance of the initial certificate of airworthiness. Given the international nature of aviation, civil aviation authorities of Member States should attempt to collaborate and consult on the details of exemptions. In the case where aeroplane type certification is done through a reciprocity agreement between Member States, the States involved should coordinate the processing of exemptions and concur before approval is granted.

2.5.2.3 Review

The competent authority should review, in a timely manner, the application using the information provided in 2.5.2.1 and the evaluation criteria in 2.5.2.2. The analysis and conclusions from the review should be communicated to the applicant in a formal response. If the application is approved, the response should clearly state the scope of the exemptions which have been granted. If the application is rejected, then the response should include a detailed justification.

2.5.3 Registration and communication

2.5.3.1 Oversight of the granted exemptions should include the following elements:

- a) The competent authority should publish details of the exempted aeroplanes in an official public register, including aeroplane model and maximum number of permitted exemptions.
- b) The applicant should have a quality control process for maintaining oversight of and managing the production of aeroplanes which have been granted exemptions.
- c) An exemption should be recorded in the aeroplane release to service document⁸ which states conformity with the type certificate. Proposed standard text: "Aeroplane exempted from Annex 16, Volume III".
- d) The applicant should provide to the competent authority, on a regular basis and appropriate to the limitation of the approval, details on the actual exempted aeroplanes which have been produced (e.g. model, aeroplane type and serial number).

⁸ European Aviation Safety Agency (EASA) Form 1, United States Federal Aviation Administration (FAA) Form 8130-4 or equivalent forms from other competent authorities.

Chapter 3 - SAR DETERMINATION PROCEDURES

3.1 SAR MEASUREMENT PROCEDURES

3.1.1 FLIGHT TEST PROCEDURES

3.1.1.1 Fuel properties

3.1.1.1.1 One of the important factors when determining the CO₂ emissions of an aeroplane according to Annex 16 Volume III is the fuel used in the flight tests.

3.1.1.1.2 Section 2.6.3 of the Annex states:

“Note. — The fuel used for each flight test shall meet the specification defined in either ASTM International D1655, DEF STAN 91-91 or equivalent.”

Equivalent fuel specifications accepted for the purposes of CO₂ emissions certification are the following:

- a) Brazil: CNP-08, QAV-1;
- b) China: GB6537 Number 3 Jet Fuel;
- c) France: DCSEA 134;
- d) Russia: GOST 10227-86 or 52050-2006, RT;
- e) USA: ASTM International D1655¹ “Standard Specification for Aviation Turbine Fuels”, Jet-A1;
- f) UK: DEF STAN 91-91² “Turbine Fuel, Kerosene Type, Jet A-1”;
- g) Similar specifications from other member states, subject to the approval of the certifying authority.

3.1.1.1.3 Section 2.5.1 of the Annex specifies the reference conditions to which the test conditions shall be corrected. The reference fuel lower heating value is specified as 43.217 MJ/kg (18 580 BTU/lb). Recommendation 1 to paragraph 3.2.1c) of Appendix 1 of the Annex states that the fuel lower heating value should be determined in accordance with methods that are at least as stringent as ASTM International D4809-09A³, “Standard Test Method for Heat of Combustion of Liquid Hydrocarbon Fuels by Bomb Calorimeter (Precision Method).” This method is estimated to have an accuracy level of the order of 0.23%.

3.1.1.1.4 Paragraph 3.2.1(d) of Appendix 1 of the Annex states that a sample of fuel shall be taken for each flight test to determine its specific gravity and viscosity when volumetric fuel-flow meters are used. The fuel’s specific gravity and viscosity need not be determined if volumetric fuel-flow meters are not used.

3.1.1.1.5 Examples of acceptable methods to determine the fuel’s specific gravity and viscosity are ASTM International D4052⁴, entitled “Standard Test Method for Density and Relative Density of Liquids by Digital Density Meter” and ASTM International D445⁵, entitled “Standard Test Method for Kinematic Viscosity of Transparent and Opaque Liquids (and Calculation of Dynamic Viscosity)”. Other methods may be used, subject to the approval of the certifying authority.

3.2 SAR DATA ANALYSIS

3.2.1 DATA SELECTION

Selection of data used to show compliance to the standard encompasses both the selection of flight test data gathered during each test condition used to obtain an individual SAR point, as well as the distribution of the resulting corrected SAR points in relation to the three reference masses and the reference conditions.

3.2.1.1 Selection of Flight Test Data

3.2.1.1.1 There are multiple methods employed by aeroplane manufacturers in selecting flight test data for analysis, reflecting a variety of tools and practices. Whichever method is chosen, the flight test data encompassed within the selected range of time is expected to meet the stability criteria detailed in Annex 16 Volume III, Appendix 1, paragraph 3.2.3.1, or alternative stability criteria approved by the certifying authority under paragraph 3.2.3.2 of that Annex 16 Volume III appendix. Test data that do not meet these stability criteria should normally be discarded. However, if such test data appears to be valid when compared with data that meet the stability criteria, and the overall stability of the conditions is reasonably bounded, these data can be retained, subject to approval of the certifying authority.

3.2.1.1.2 One acceptable method is to employ an algorithm that automatically selects the data that meets all the stability criteria, and discards data that does not. This method could be used to select the longest possible duration SAR point that meets the required stability criteria, or could be used to select multiple SAR points of the minimum requirement duration (one minute) providing these points are separated by a minimum of two minutes or by an exceedance of the stability criteria as specified in paragraph 3.2.2.2 of Annex 16 Volume III, Appendix 1. Using a defined algorithm to select data in an automated process allows repeatable and consistent application to other SAR points. This method may also yield a greater number of SAR points to be used in defining the CO₂ metric value and should represent a good statistical distribution. However, because the amount of test data included in each SAR point is maximized, the resulting SAR points could exhibit more scatter than if additional selection criteria are used.

3.2.1.1.3 Another method is to more closely examine the collected flight test data and select the timeframe to be used to define the SAR point, by choosing the best or most stable data available and ignoring less stable data that technically still meets the stability criteria. Examples of this are presented in Figures 3.2-1 and 3.2-2.

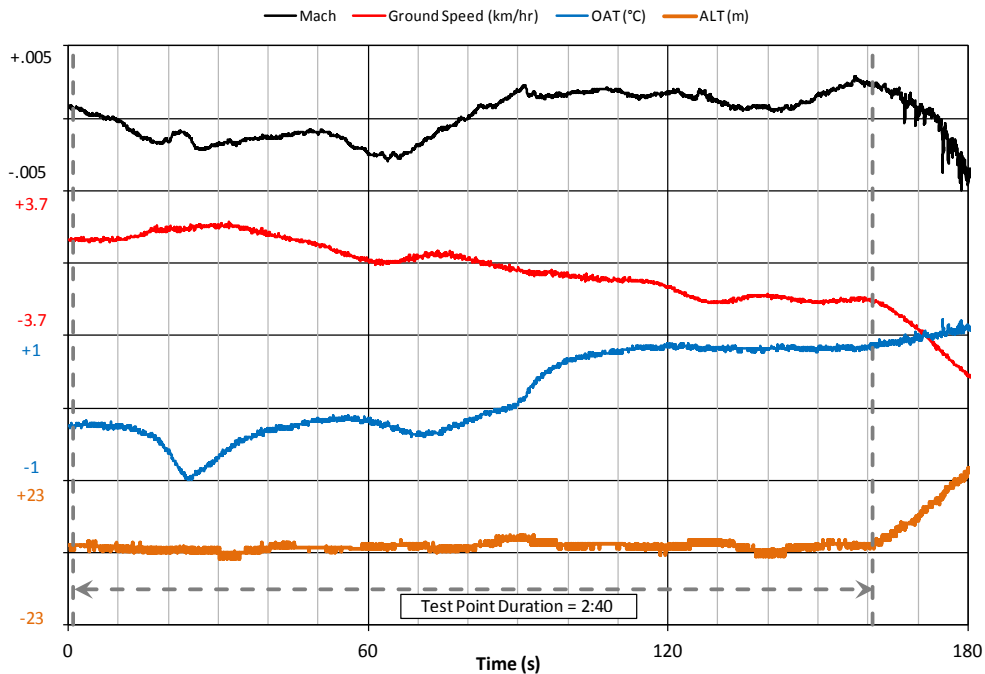

Figure 3.4-1 – Flight test data time interval selection – Example 1

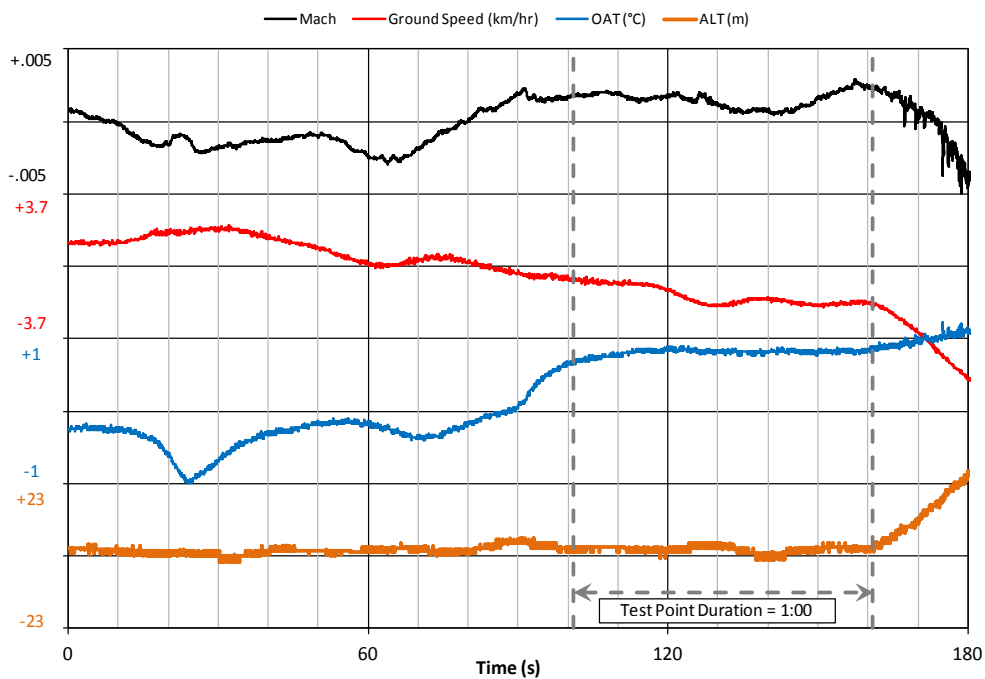

Figure 3.4-2 – Flight test data time interval selection – Example 2

3.2.1.1.4 The first graph shows that the plotted parameters stay within the tolerances allowed by the stability criteria for the duration of the test condition. (The changing altitude after the end of the condition reflects pilot input to leave steady flight and transition to the next test condition.) While all parameters are within the required tolerances, fluctuations in ambient temperature and Mach are evident. The second graph shows the same data, but with a manually selected range of shorter duration where the parameters are more stable.

3.2.1.1.5 Selecting data that meets more demanding stability criteria, instead of using all data that meets the Annex 16 Volume III stability criteria, may allow the applicant to filter out observed instabilities caused by air quality, changing environmental conditions, flight control inputs, and aeroplane system dynamics. This could result in a SAR point that is actually more representative of actual aeroplane performance.

3.2.1.1.6 Whichever approach is taken to select data to define SAR points, it is important the methodology be applied as consistently as possible, to minimize potential unseen bias in the resulting distribution of SAR points.

3.2.1.1.7 Another important aspect to consider when selecting data is to ensure that the time interval chosen is representative of the aeroplane's performance, and not indicative of a larger trend. For example, the first plot in Figure 3.2-3 shows a trend line drawn through ground speed data over a 60 second time interval. This ground speed data meets the stability criteria, and taken alone would indicate the need for an energy correction. However, if the ground speed data trace was continued over a longer time interval, it becomes apparent that it exhibits cyclic behaviour. Cyclic data need not be discarded necessarily, but the applicant should ensure that an appropriate time interval is selected such that the arithmetic average is representative. In the example shown in Figure 3.2-3, an energy correction would be inappropriate.

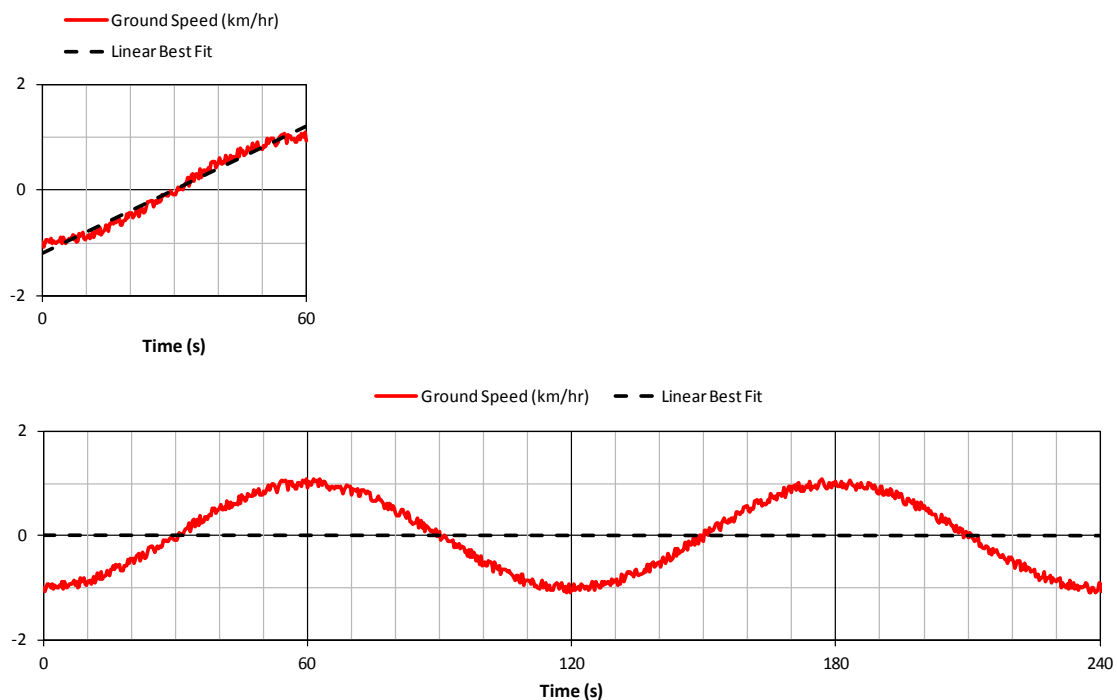

Figure 3.4-3 – Cyclic behavior example

3.2.1.2 Distribution of Resulting SAR points

3.2.1.2.1 Once the individual SAR points have been selected and corrected to reference conditions, they should be examined to ensure they present an accurate representation of aeroplane performance.

3.2.1.2.2 For example, if direct flight test is being used to collect 6 SAR points targeting one reference mass, those 6 points when corrected to reference conditions should result in a reasonable grouping. If 5 of the points form a reasonable grouping and one point is a clear outlier, the offending point may require closer scrutiny to ensure it is actually representative. In such a situation, collection of additional data may be warranted, or, if appropriate, and subject to approval by the certificating authority, the offending data point could be discarded.

3.2.1.2.3 If the applicant conducts tests across a range of weights to build a regression line of SAR versus weight, the collected SAR points should be reasonably distributed across the weight range. If a large portion of the regression line is unsupported by data, or is anchored by a single SAR point, then the SAR determined for one of the reference masses may be suspect. This is an important aspect to consider during the development of the certification plan and flight test programme. As with the direct test method, if a single SAR point appears to be an outlier compared to the rest of the data points, it should be examined more closely and could potentially be discarded.

3.2.1.2.4 The applicant should investigate the collection of SAR points for potential sources of unintended bias, for example if all of the data points collected were during periods where groundspeed was increasing. If all of the test points require a large energy correction in one direction, resulting in all SAR point being significantly increased (or decreased), further scrutiny may be required to ensure a bias is not introduced, depending on the test data and correction techniques being used.

3.2.2 CORRECTIONS TO REFERENCE CONDITIONS

3.2.1.2 **General.** The guidance provided here represents one set of methods, but not the only acceptable methods, for correcting the specific air range test data to the reference conditions specified in paragraph 2.5 of Annex 16 Volume III Part II.

3.2.1.2.1 Care needs to be taken not to inadvertently account for a correction twice when making any of the corrections below. For example, when adjusting to the reference Mass/ δ from the test Mass/ δ , a drag correction is introduced to account for the change in lift coefficient (C_L). This change in C_L , at a constant Mach number, also changes the reference Reynolds number and the reference mass. However, these additional changes may already be accounted for in the drag adjustments for off-nominal Reynolds number and aeroelastics depending on the correction methods used.

3.2.1.2.2 The corrections identified in paragraphs 3.2.2.2 through 3.2.2.12 cover corrections that should be made to the tested values of aeroplane mass, drag, and fuel flow. These corrected values of aeroplane mass, drag, and fuel flow should then be used to determine SAR for the reference conditions in the following manner:

3.2.1.2.2.1 Determine the aeroplane mass corrected to reference conditions per paragraph 3.2.2.2. Use this mass as the reference mass in paragraphs 3.2.2.3.2, 3.2.2.4.1, and 3.2.2.7.1, and as the mass for determining the aeroplane drag in paragraph 3.2.2.1.2.2.

3.2.1.2.2.2 Determine the aeroplane drag for the test condition using the mass corrected for gravitational acceleration. Determine all of the drag corrections per paragraphs 3.2.2.3, 3.2.2.4, 3.2.2.5, 3.2.2.6, and 3.2.2.7. Sum these drag corrections and add to the aeroplane drag for the test condition to obtain the aeroplane drag corrected to the reference conditions.

3.2.1.2.2.3 Use the drag level corrected to reference conditions from paragraph 3.2.2.1.2.2 as a thrust level (thrust = drag) to determine the total engine fuel flow for these conditions from an engine performance model. Correct this engine fuel flow to reference conditions per paragraphs 3.2.2.8, 3.2.2.9, 3.2.2.10, 3.2.2.11, and 3.2.2.12.

3.2.1.2.2.4 The SAR value corrected to reference conditions is given by the following relationship:

$$SAR_{ref} = \left(\frac{TAS}{Fuel\ Flow_{ref}} \right)$$

Where SAR_{ref} is the specific air range for the reference conditions in kilometers/kilogram,

TAS is the aeroplane true airspeed for the test condition in kilometers/hour, and

$Fuel\ Flow_{ref}$ is the engine fuel flow for the reference conditions (from paragraph 3.2.2.1.2.3) in kilograms/hour.

3.2.1.3 **Apparent gravity.** Acceleration, caused by the local effect of gravity, and inertia, affects the test weight of the aeroplane. The apparent gravity at the test conditions varies with latitude, altitude, ground speed, and direction of motion relative to the Earth's axis. The reference gravitational acceleration is the gravitational acceleration for the aeroplane travelling in the direction of true North in still air at the reference altitude, a geodetic latitude of 45.5 degrees, and based on g_0 .

3.2.1.3.1 Since the mass of the aeroplane during each test condition cannot be directly measured, it is determined from the test weight that has been corrected for gravitational acceleration. The test mass corrected for gravitational acceleration, which is to be used in paragraphs 3.2.2.3.2, 3.2.2.4.1, and 3.2.2.7.1, should be determined from the following equation:

$$Mass_{grav} = \left(\frac{W_t + \Delta W_{grav}}{g_0} \right)$$

$Mass_{grav}$ is the average mass of the aeroplane during the test condition corrected for gravitational acceleration in kilograms,

W_t is the average weight of the aeroplane during the test condition in newtons, and

g_0 is the standard gravitational acceleration = 9.80665 meters/second².

3.2.1.3.2 The following corrections are based on the World Geodetic System 84 Ellipsoidal Gravity definition. Other formulations and simplifications may provide essentially equivalent results.

3.2.1.3.3 The correction to the test weight for the effect of the variation in gravitational acceleration from the reference gravitational acceleration, can be determined from the following equation:

$$\Delta W_{grav} = W_t \left(\frac{g_{\phi,alt} + \Delta g_{cent} + \Delta g_{Coriolis} - g_{Ref}}{g_{ref}} \right)$$

Where ΔW_{grav} is the weight correction in newtons for being off the reference gravitational acceleration,

W_t is the average weight of the aeroplane during the test condition in newtons,

$g_{\phi,alt}$ is the gravitational acceleration at the test altitude and latitude in meters/second²,

Δg_{cent} is the change in the gravitational acceleration due to centrifugal effect in meters/second²,

$\Delta g_{Coriolis}$ is the change in the gravitational acceleration due to Coriolis effect in meters/second², and

g_{ref} is the reference gravitational acceleration in meters/second².

3.2.1.3.4 The gravitational acceleration for the test altitude and latitude, $g_{\phi,alt}$, is determined as follows:

- a. First determine the gravitational effect of latitude at sea level from the following equation:

$$g_{\phi} = \left(9.7803267714 \frac{1 + 0.00193185138639 \sin^2 \phi}{\sqrt{1 - 0.00669437999013 \sin^2 \phi}} \right)$$

Where ϕ is the test latitude in degrees.

- b. The gravitational acceleration for the test altitude and latitude is then determined from the following equation:

$$g_{\phi,alt} = g_{\phi} \left(\frac{r_e}{r_e + h} \right)^2$$

Where g_{ϕ} is the gravitational acceleration at the test latitude at sea level (from paragraph 3.2.2.2.4.a),

h is the test altitude in meters, and

r_e is the radius of the Earth at the test latitude, which is determined from the following equation:

$$r_e = \sqrt{\frac{(a^2 \cos^2 \phi) + (b^2 \sin^2 \phi)}{(a \cos \phi)^2 + (b \sin \phi)^2}}$$

Where a is the Earth's radius at the equator = 6378137 meters,

b is the Earth's radius at the pole = 6356752 meters, and

3.2.1.3.5 The change in the gravitational acceleration due to centrifugal effect, Δg_{cent} , is determined from the following equation:

$$\Delta g_{cent} = -\frac{V_g^2}{r_e + h}$$

Where V_g is the ground speed in meters/second,

r_e is the radius of the Earth in meters at the test latitude, which is determined from the following equation:

$$r_e = \sqrt{\frac{(a^2 \cos \phi)^2 + (b^2 \sin \phi)^2}{(a \cos \phi)^2 + (b \sin \phi)^2}}, \text{ and}$$

h is the test altitude in meters.

3.2.1.3.6 The change in the gravitational acceleration due to Coriolis effect, g_{Coriolis} , can be found from the following equation:

$$g_{\text{Coriolis}} = -2 \omega_E V_g \cos \phi \sin \sigma$$

Where ω_E is the Earth's rotation rate = 7.29212×10^{-5} radians/second,

V_g is the aeroplane's ground speed in meters/second,

ϕ is the test latitude in degrees, and

σ is the ground track angle of the aeroplane in degrees.

3.2.1.3.7 The reference gravitational acceleration, g_{ref} , is the gravitational acceleration for the aeroplane travelling in the direction of true North in still air at the reference altitude and a geodetic latitude of 45.5 degrees. Because the reference gravitational acceleration condition is for the aeroplane travelling in the direction of true North, the reference gravitational acceleration does not include any Coriolis effect. Because the reference condition is for the aeroplane travelling in still air, the effect of the centrifugal effect on the reference gravitational acceleration is determined using the aeroplane's true airspeed (i.e. zero wind ground speed). The reference gravitational acceleration can be determined as follows:

3.2.2.2.7.1 Determine the reference gravitational acceleration for the reference altitude and latitude using the process defined in paragraph 3.2.2.2.4, using the reference altitude and 45.5 degrees latitude as the test altitude and latitude, respectively.

3.2.2.2.7.2 Determine the change in the reference gravitational acceleration due to centrifugal effect using the process defined in 3.2.2.2.5, using the aeroplane's true airspeed as the ground speed.

3.2.2.2.7.3 The reference gravitational acceleration, g_{ref} , is the sum of the reference gravitational acceleration for the reference altitude determined in 3.2.2.2.7.1 and the change in the reference gravitational acceleration due to centrifugal effect determined in 3.2.2.2.7.2.

3.2.1.4 **Mass/ δ** . The lift coefficient of the aeroplane is a function of mass/ δ and Mach number, where δ is the ratio of the atmospheric pressure at a given altitude to the atmospheric pressure at sea level. The lift coefficient for the test condition affects the drag of the aeroplane. The reference mass/ δ is derived from the combination of the reference mass, reference altitude, and atmospheric pressures determined from the ICAO standard atmosphere.

3.2.1.4.1 The effect on drag of the test condition mass/ δ being different than the reference mass/ δ can be determined from the drag equation:

$$\Delta D_{Mass/\delta} = \frac{1}{2} \rho V^2 \left(C_{D\ Ref\ Mass/\delta} - C_{D\ Test\ Mass/\delta} \right) A$$

Where $\Delta D_{Mass/\delta}$ is the drag correction in newtons due to the test mass/ δ being different than the reference mass/ δ ,

ρ is the density of air at the test altitude and test temperature in kilograms/meter³,

V is the aeroplane's average true airspeed during the test condition in meters/second,

A is the aeroplane's reference wing area in meters²,

$C_{D\ Ref\ Mass/\delta}$ is the drag coefficient from the aeroplane's drag model at the reference mass/ δ , and

$C_{D\ Test\ Mass/\delta}$ is the drag coefficient from the aeroplane's drag model at the test mass/ δ .

3.2.1.4.2 The aeroplane's drag coefficient in the aeroplane's drag model is a function of the lift coefficient. Given the lift coefficient, the drag coefficient can be determined. The lift coefficients at the reference mass/ δ and test mass/ δ can be determined from the lift equation:

$$C_L = \left(\frac{Mass/\delta}{7232.4 M^2 A} \right)$$

Where C_L is the lift coefficient,

Mass/ δ is the mass/ δ of the aeroplane in kilograms (either the test mass/ δ after correcting the test mass for gravitational acceleration, or the reference mass/ δ , depending on which C_L value is being determined. (Note: δ is the ratio of the ambient air pressure at a specified altitude (reference or test) to the ambient air pressure at sea level)),

M is the aeroplane's average Mach number during the test condition, and

A is the aeroplane's reference wing area in meters².

3.2.1.5 **Acceleration/deceleration (energy).** Drag determination is based on an assumption of steady, unaccelerated flight. Acceleration or deceleration occurring during a test condition affects the assessed drag level. The reference condition is steady, unaccelerated flight.

3.2.1.5.1 The correction for the change in drag force resulting from acceleration during the test condition can be determined from the following equation:

$$\Delta D_{accel} = -M_{grav} \left(\frac{dV_G}{dT} \right)$$

Where ΔD_{accel} is the drag correction in newtons due to acceleration occurring during the test condition,

M_{grav} is the average mass of the aeroplane during the test condition corrected for gravitational acceleration in

kilograms, and

(dV_G/dT) is the change in ground speed over time during the test condition in meters/second².

3.2.1.6 **Reynolds number.** The Reynolds number affects aeroplane drag. For a given test condition the Reynolds number is a function of the density and viscosity of air at the test altitude and temperature. The reference Reynolds number is derived from the density and viscosity of air from the ICAO standard atmosphere at the reference altitude and temperature.

3.2.1.6.1 The value of the drag coefficient correction for being off the reference Reynolds number condition during the test can be expressed as:

$$\Delta C_{D RE} = -B \log \left[\frac{\frac{1}{M} \left(\frac{RE}{meters} \right)_{test}}{\frac{1}{M} \left(\frac{RE}{meters} \right)_{Ref}} \right]$$

Where $\Delta C_{D RE}$ is the change in drag coefficient due to being off the reference Reynolds number,

B is a value representing the variation of drag with Reynolds number for the specific aeroplane (see paragraph 3.2.2.5.2),

M is Mach number, and

RE is Reynolds number.

3.2.1.6.2 One method to obtain B is to use a drag model to obtain the incremental drag variation in response to changing Mach and altitude from a reference cruise condition. The value for B is the value of a single representative slope of a plot of the drag variation, ΔDrag versus $\text{Log}_{10} \left[\frac{1}{M} \left(\frac{RE}{meter} \right) \times 10^{-6} \right]$.

3.2.1.6.3 The term $\left[\frac{\frac{1}{M} \left(\frac{RE}{meter} \right)_{test}}{\frac{1}{M} \left(\frac{RE}{meter} \right)_{Ref}} \right]$ is the term $\frac{1}{M} \left(\frac{RE}{meter} \right)$ determined at the temperature and altitude for the test condition divided by the same term determined at the standard day temperature and the reference altitude for the test mass/ δ using the following equation:

$$\frac{1}{M} \frac{RE}{meter} = 4.7899 \times 10^5 P_S \left(\frac{T_S + 110.4}{T_S^2} \right)$$

Where RE/meter is Reynolds number per meter,

P_S is static pressure in pascals, and

T_S is static temperature in Kelvin.

3.2.1.6.4 The effect on aeroplane drag can then be determined from $\Delta C_{D RE}$ and the aeroplane drag equation as follows:

$$\Delta D_{RE} = \frac{1}{2} \rho V^2 \Delta C_{D RE} A$$

Where ΔD_{RE} is the aeroplane drag correction in newtons due to the test Reynolds number being different than the reference Reynolds number,

ρ is the density of air at the test altitude and test temperature in kilograms/meter³,

V is the aeroplane's average true airspeed during the test condition in meters/second,

A is the aeroplane's reference wing area in meters², and

$\Delta C_{D RE}$ is the change in drag coefficient due to being off the reference Reynolds number from paragraph 3.2.2.5.1.

3.2.1.7 **CG position.** The position of the aeroplane centre of gravity affects the drag due to longitudinal trim.

3.2.1.7.1 The drag correction for being off the reference CG position during the test is the difference between the drag at the reference CG position and the drag at the test CG position. This drag correction can be determined by: (1) determining the lift coefficient at the reference and test CG positions; (2) using the aeroplane's drag model with the lift coefficients for the test and reference CG positions to determine the respective drag coefficients; and (3) using the drag equation with the test and reference CG drag coefficients to determine difference in aeroplane drag between the reference and test CG positions.

3.2.1.7.2 The lift coefficient at the test CG position can be determined by using the lift equation in paragraph 3.2.2.3.2. The lift coefficient at the reference CG position can be determined from the following equation:

$$C_{L Ref CG} = C_{L Test} [1 + (MAC/L_t) (CG_{Ref} - CG_{Test})]$$

Where MAC is the length of the wing mean aerodynamic chord in centimeters,

L_t is the length of the horizontal stabilizer arm (normally measured between the wing 25 percent MAC and the stabilizer 25 percent MAC) in centimeters,

CG_{Ref} is the reference CG position in percent MAC/100, and

CG_{Test} is the CG position in percent MAC/100 during the test condition.

3.2.1.7.3 Once the drag coefficients are determined from the aeroplane drag model using the lift coefficients above, the aeroplane drag for the reference and test CG positions can be determined from the drag equation:

$$\Delta D_{CG} = \frac{1}{2} \rho V^2 (C_{D Test CG} - C_{D Ref CG}) A$$

Where ΔD_{CG} is the aeroplane drag correction in newtons due to the test CG being different than the reference CG,

ρ is the density of air at the test altitude and test temperature kilograms/meter³,

V is the aeroplane's average true airspeed during the test condition in meters/second,

A is the aeroplane's reference wing area in meters², and

$C_{D \text{ Test CG}}$ and $C_{D \text{ Ref CG}}$ are the drag coefficient from the aeroplane's drag model at the test condition CG and reference CG positions, respectively.

3.2.1.8 Aeroelastics. Wing aeroelastics may cause a variation in drag as a function of aeroplane wing mass distribution. Aeroplane wing mass distribution will be affected by the fuel load distribution in the wings and the presence of any external stores.

3.2.1.8.1 There are no simple analytical means to correct for different wing structural loading conditions. If necessary, corrections to the reference condition should be developed by flight test or a suitable analysis process.

3.2.1.8.2 The reference condition for the wing structural loading is to be selected by the applicant based on the amount of fuel and/or removable external stores to be carried by the wing based on the aeroplane's payload capability and the manufacturer's standard fuel management practices. The reference to the aeroplane's payload capability is to establish the zero fuel mass of the aeroplane, while the reference to the manufacturer's standard fuel management practices is to establish the distribution of that fuel and how that distribution changes as fuel is burned.

3.2.1.8.3 The reference condition for the wing structural loading reference condition should be based on an operationally representative empty weight and payload, which defines the zero fuel mass of the aeroplane. The total amount of fuel loaded for each of the three reference masses would be the reference mass minus the zero fuel mass. Standard fuel management practices will determine the amount of fuel present in each fuel tank. An example of standard fuel management practice is to load the main (wing) fuel tanks before loading the center (body) fuel tanks and to first empty fuel from the center tanks before using the fuel in the main tanks. This helps keep the cg aft, and reduces trim drag.

3.2.1.8.4 Commercial freighters may be designed from scratch, but more often are derivatives of, or are converted from passenger models. For determining aeroelastic effects, it is reasonable to assume that the reference loading for a freighter is the same as the passenger model it was derived from. If there is no similar passenger model, the reference zero-fuel-mass of a freighter can be based on its payload design density. The payload design density is defined by the full use of the volumetric capacity of the freighter and the highest mass it is designed to carry in this configuration, expressed in kg/m³. For example, a typical payload design density for large commercial freighters is 160 kg/m³.

3.2.1.8.5 Using a reference payload significantly lower the passenger interior limits or structural limited payload could potentially provide a more beneficial aeroelastic effect. An applicant would need to justify the reference payload assumptions in the context of the capability of the aeroplane and what could be considered typical for the configuration.

3.2.1.9 **Fuel lower heating value.** The fuel lower heating value defines the energy content of the fuel. The lower heating value directly affects the fuel flow at a given test condition.

The fuel flow measured during the flight test is corrected to the fuel flow for the reference lower heating value as follows:

$$Fuel\ Flow_{Corr\ LHV} = Fuel\ Flow_{test\ LHV} \left(\frac{LHV_{test}}{LHV_{Ref}} \right)$$

Where $Fuel\ Flow_{Corr\ LHV}$ is the fuel flow in kilograms/hour corrected for the reference fuel lower heating value,

$Fuel\ Flow_{test\ LHV}$ is the measured fuel flow in kilograms/hour during the test (at the test fuel lower heating value,

LHV_{test} is the fuel lower heating value of the fuel used for the test in MJ/kg, and

LHV_{Ref} is the reference fuel lower heating value = 43.217 MJ/kg.

3.2.1.10 **Altitude.** The altitude at which the aeroplane is flown affects the fuel flow.

3.2.1.10.1 The engine model should be used to determine the difference between the fuel flow at the test altitude and the fuel flow at the reference altitude. The fuel flow at the test altitude should be corrected by this value so that it represents the fuel flow that would have been obtained at the reference altitude.

3.2.1.11 **Temperature.** The ambient temperature affects the fuel flow. The reference temperature is the standard day temperature from the ICAO standard atmosphere at the reference altitude.

3.2.1.11.1 The engine model should be used to determine the difference between the fuel flow at the test temperature and the fuel flow at the reference temperature. The fuel flow at the test temperature should be corrected by this value so that it represents the fuel flow that would have been obtained at the reference temperature.

3.2.1.12 **Engine deterioration level.** When first used, engines undergo a rapid, initial deterioration in fuel efficiency. Thereafter, the rate of deterioration significantly decreases. Engines with less than the reference deterioration level may be used, subject to the approval of the certification authority. In such a case, the fuel flow shall be corrected to the reference engine deterioration level, using an approved method. Engines with more deterioration than the reference engine deterioration level may be used. In this case a correction to the reference condition shall not be permitted.

3.2.1.12.1 As stated above, a correction should not generally be made for engine deterioration level. If an applicant proposes to use an engine or engines with less than the reference deterioration level for testing, it may be possible to establish a conservative correction level to apply to the test fuel flow to represent engines at the reference deterioration level. Such a correction should be substantiated by engine fuel flow deterioration data from the same engine type or family.

3.2.1.13 **Electrical and mechanical power extraction and bleed flow.** Electrical and mechanical power extraction and bleed flow affects the fuel flow.

3.2.1.13.1 The engine model should be used to determine the difference between the fuel flow at the test power extraction and bleed flow and the fuel flow at the reference power extraction and bleed flow. The fuel flow at the test power extraction and bleed flow should be corrected by this value so that it represents the fuel flow that would have been obtained at the reference power extraction and bleed flow.

3.3 VALIDITY OF RESULTS - CONFIDENCE INTERVAL

3.3.1 INTRODUCTION

3.3.1.1 Sections 3.3.2 to 3.3.4 provide an insight into the theory of confidence interval evaluation. Application of this theory and some worked examples are provided in 3.3.4. A suggested bibliography is provided in Appendix 2 to this manual for those wishing to gain a greater understanding.

3.3.2 DIRECT FLIGHT TESTING

3.3.2.1 If n measurements of SAR y_1, y_2, \dots, y_n are obtained under approximately the same conditions and it can be assumed that they constitute a random sample from a normal population with true population mean, μ , and true standard deviation, σ , then the following statistics can be derived:

$$\bar{y} = \text{estimate of the mean} = \frac{1}{n} \left\{ \sum_{i=1}^{i=n} y_{(i)} \right\}$$

$$s = \text{estimate of the standard deviation of the mean} = \sqrt{\frac{\sum_{i=1}^{i=n} (y_i - \bar{y})^2}{n - 1}}$$

From these and the Student's t-distribution, the confidence interval, CI, for the estimate of the mean, \bar{y} can be determined as:

$$CI = \bar{y} \pm t_{\left(1-\frac{\alpha}{2}, \zeta\right)} \frac{s}{\sqrt{n}}$$

Where $t_{\left(1-\frac{\alpha}{2}, \zeta\right)}$ denotes the $\left(1 - \frac{\alpha}{2}\right)$ percentile of the single-sided Student's t-test with ζ degrees freedom (for a clustered data set $\zeta = n - 1$) and where α is defined such that $100(1 - \alpha)$ per cent is the desired confidence level for the confidence interval. In other words it denotes the probability with which the interval will contain the unknown mean, μ . For CO2 certification purposes, 90 per cent confidence intervals are generally desired and thus $t_{.95, \zeta}$ is used. See Table 3.3-1 for a listing of values of $t_{.95, \zeta}$ for different values of ζ .

3.3.3 REGRESSION MODEL

3.3.3.1 If n measurements of SAR (y_1, y_2, \dots, y_n) are obtained under significantly varying values of mass (x_1, x_2, \dots, x_n) respectively, then a polynomial can be fitted to the data by the method of least squares. For determining the mean SAR, μ , the following polynomial regression model is assumed to apply:

$$\mu = B_0 + B_1x + B_2x^2 + \dots + B_kx^k .$$

The estimate of the mean line through the data of the SAR is given by:

$$y = b_0 + b_1x + b_2x^2 + \dots + b_kx^k .$$

Each regression coefficient (B_i) is estimated by b_i from the sample data using the method of least squares in a process summarized as follows.

Each observation (x_i, y_i) satisfies the equations:

$$\begin{aligned} y_i &= B_0 + B_1x_i + B_2x_i^2 + \dots + B_kx_i^k + \varepsilon_i \\ &= b_0 + b_1x_i + b_2x_i^2 + \dots + b_kx_i^k + e_i , \end{aligned}$$

where ε_i and e_i are, respectively, the random error and residual associated with the SAR. The random error ε_i is assumed to be a random sample from a normal population with mean zero and standard deviation σ . The residual (e_i) is the difference between the measured value and the estimate of the value using the estimates of the regression coefficients and x_i . Its root mean square value (s) is the sample estimate for σ . These equations are often referred to as the normal equations.

Table 3.3-1. Student's t-distribution (for 90 per cent confidence) for various degrees of freedom

Degrees of freedom (ζ)	$t_{.95, \zeta}$
1	6.314
2	2.920
3	2.353
4	2.132
5	2.015
6	1.943
7	1.895
8	1.860
9	1.833

<i>Degrees of freedom</i> (ζ)	$t_{.95, \zeta}$
10	1.812
12	1.782
14	1.761
16	1.746
18	1.734
20	1.725
24	1.711
30	1.697
60	1.671
>60	1.645

The n data points of measurements (x_i, y_i) are processed as follows:

Each elemental vector (\underline{x}_i) and its transpose (\underline{x}'_i) are formed such that:

$\underline{x}_i = (1 \quad x_i \quad x_i^2 \quad \dots \quad x_i^k)$, a row vector; and

$\underline{x}'_i = \begin{pmatrix} 1 \\ x_i \\ x_i^2 \\ \vdots \\ x_i^k \end{pmatrix}$, a column vector.

A matrix \underline{X} is formed from all the elemental vectors \underline{x}_i for $i = 1, \dots, n$. \underline{X}' is the transpose of \underline{X} . A matrix \underline{A} is defined such that $\underline{A} = \underline{X}'\underline{X}$ and a matrix \underline{A}^{-1} is the inverse of \underline{A} . In addition, $\underline{y} = (y_1 \ y_2 \ \dots \ y_n)$, and $\underline{b} = (b_0 \ b_1 \ \dots \ b_2)$, with \underline{b} determined as the solution of the normal equations:

$$\underline{y} = \underline{X}\underline{b} \quad \text{and} \quad \underline{X}'\underline{y} = \underline{X}'\underline{X}\underline{b} = \underline{A}\underline{b},$$

to give

$$\underline{b} = \underline{A}^{-1} \underline{X}' \underline{y} .$$

The 90 per cent confidence interval CI_{90} for the mean value of the SAR estimated with the associated value of the mass x_0 is then defined as:

$$CI_{90} = \bar{y}(x_0) \pm t_{.95, \zeta} s v(x_0) ,$$

where $v(x_0) = \sqrt{\underline{x}_0 \underline{A}^{-1} \underline{x}'_0}$.

Thus $CI_{90} = \bar{y}(x_0) \pm t_{.95, \zeta} s \sqrt{\underline{x}_0 \underline{A}^{-1} \underline{x}'_0}$,

where:

- $\underline{x}_0 = (1 \ x_0 \ x_0^2 \ \dots \ x_0^k)$;
- \underline{x}'_0 is the transpose of \underline{x}_0 ;
- $\bar{y}(x_0)$ is the estimate of the mean value of the SAR at the associated value of the mass x_0 ;
- $t_{.95, \zeta}$ is obtained for ζ degrees of freedom. For the general case of a multiple regression analysis involving K independent variables (i.e. $K + 1$ coefficients) ζ is defined as $\zeta = n - K - 1$ (for the specific case of a polynomial regression analysis, for which k is the order of curve fit, there are k variables independent of the dependent variable, and so $\zeta = n - k - 1$); and

- $s = \sqrt{\frac{\sum_{i=1}^{i=n} (y_i - \bar{y}(x_i))^2}{n - K - 1}}$, the estimate of σ , the true standard deviation.

3.3.4 WORKED EXAMPLES OF THE DETERMINATION OF 90 PER CENT CONFIDENCE INTERVALS

3.3.4.1 Direct Flight Testing

3.3.4.1.1 Example 1: the Confidence Interval is less than the confidence interval limit

Let's consider the following set of 6 independent measurements of SAR obtained by flight test around one of the three reference masses of the CO2 emissions evaluation metric. After correction to reference conditions, the following clustered data set of SAR values is obtained:

<i>Measurement number</i>	<i>Corrected SAR (km/kg)</i>
1	0.38152
2	0.38656
3	0.37988
4	0.38011
5	0.38567
6	0.37820

Table 3.3-2 - Measurements of SAR – Example 1

- The number of data points (n) = 6

- The degrees of freedom (n-1) = 5

- The Student's t-distribution for 90 per cent confidence and 5 degrees of freedom ($t_{(.95,5)}$) = 2.015 (see Table 3.3-1)

Note: 6 is the minimum number of test points requested by Appendix 1 of Annex 16 Volume 3, §6.2.

Estimate of the mean SAR (\overline{SAR}) for the clustered data set

$$\overline{SAR} = \frac{1}{n} \left\{ \sum_{i=1}^{i=n} SAR_{(i)} \right\} = 0.38282 \text{ km/kg}$$

Estimate of the standard deviation (s)

$$s = \sqrt{\frac{\sum_{i=1}^{i=n} (SAR_{(i)} - \overline{SAR})^2}{n-1}} = 0.00344 \text{ km/kg}$$

Confidence Interval determination

The 90 per cent confidence interval (CI_{90}) is calculated as follows (see §3.3.2):

$$CI_{90} = \overline{SAR} \pm t_{(.95, n-1)} \frac{s}{\sqrt{n}} = 0.38282 \pm 2.015 \times \frac{0.00344}{\sqrt{6}} = 0.38282 \pm 0.00283 \text{ km/kg}$$

Check of confidence interval limits

The confidence interval extends to ± 0.00283 km/kg around the mean SAR value of the clustered data set (0.38282 km/kg). This represents ± 0.74 per cent of the mean SAR value, which is below the confidence interval limit of 1.5 per cent defined in Annex 16 Volume 3 Appendix 1 §6.4.

As a result, the SAR value of 0.38282 km/kg associated to one of the reference masses of the CO₂ emissions evaluation metric can be used for the metric determination.

3.3.4.1.2 Example 2: the confidence Interval exceeds the confidence interval limit

Let's consider the following set of 6 independent measurements of SAR obtained by flight test around one of the three reference masses of the CO₂ emissions evaluation metric. After correction to reference conditions, the following clustered data set of SAR values is obtained:

<i>Measurement number</i>	<i>Corrected SAR (km/kg)</i>
1	0.15208
2	0.15795
3	0.15114
4	0.15225
5	0.15697
6	0.15834

Table 3.3-3 – Measurements of SAR – Example 2

- The number of data points (n) = 6
- The degrees of freedom (n-1) = 5
- The Student's t-distribution for 90 per cent confidence and 5 degrees of freedom ($t_{(.95,5)}$) = 2.015 (see Table 3.3-1)

Estimate of the mean SAR (\overline{SAR}) for the clustered data set

$$\overline{SAR} = \frac{1}{n} \left\{ \sum_{i=1}^{i=n} SAR_{(i)} \right\} = 0.15479 \text{ km/kg}$$

Estimate of the standard deviation (s)

$$s = \sqrt{\frac{\sum_{i=1}^{i=n} (SAR_{(i)} - \overline{SAR})^2}{n - 1}} = 0.0033 \text{ km/kg}$$

Confidence Interval determination

The 90 per cent confidence interval (CI_{90}) is calculated as follows (see §3.3.2):

$$CI_{90} = \overline{SAR} \pm t_{(.95,n-1)} \frac{s}{\sqrt{n}} = 0.15479 \pm 2.015 \times \frac{0.0033}{\sqrt{6}} = 0.15479 \pm 0.00271 \text{ km/kg}$$

Check of confidence interval limits

The confidence interval extends to ± 0.00271 km/kg around the mean SAR value of the clustered data set (0.15479 km/kg). This represents ± 1.75 per cent of the mean SAR value, which is above the confidence interval limit of 1.5 per cent defined in Annex 16 Volume 3 Appendix 1 §6.4.

In such a case, a penalty equal to the amount that the 90 per cent confidence interval exceeds ± 1.5 per cent shall be applied to the mean SAR value, i.e. $(1.75 - 1.50) = 0.25$ per cent. The mean SAR value shall therefore be penalized by an amount of 0.25 per cent as follows:

$$\overline{SAR} = \left(1 - \frac{0.25}{100}\right) \times 0.15479 = 0.15440 \text{ km/kg}$$

As a result, the SAR value of 0.15440 km/kg associated to one of the reference masses of the CO₂ emissions evaluation metric can be used for the metric determination.

3.3.4.2 Regression model

3.3.4.2.1 Example 3: the confidence Interval at each of the three reference masses of the CO₂ emissions evaluation metric is less than the confidence interval limit

Let's consider the following set of 12 measurements of SAR obtained by flight test at optimum speed and optimum altitude as a function of the aeroplane gross mass. After SAR correction to reference conditions, the following data set is obtained:

<i>Measurement Number & Reference Mass</i>	<i>Gross Mass (m_i) (kg)</i>	<i>Corrected SAR (SAR_i) (km/kg)</i>
1	17800	0.928
Low Mass ^(*)	17825	
2	17970	0.905
3	18400	0.908
4	18850	0.884
5	19500	0.850
6	19950	0.845
Mid Mass ^(*)	19953	
7	20180	0.833
8	20350	0.818
9	21000	0.792
10	21500	0.781
11	21870	0.779
High Mass ^(*)	22080	
12	22150	0.771

Table 3.3-4 – Measurements of SAR – Example 3

^(*) Low, Mid and High mass represent the reference masses of the CO₂ emissions evaluation metric defined in Annex 16, Volume 3, Chapter 2, §2.3.

The number of data points (n) = 12

Note: 12 is the minimum number of test points requested by Appendix 1 of Annex 16 Volume 3, §6.3.

A representation of above measurement points is proposed in below figure 3.3-1.

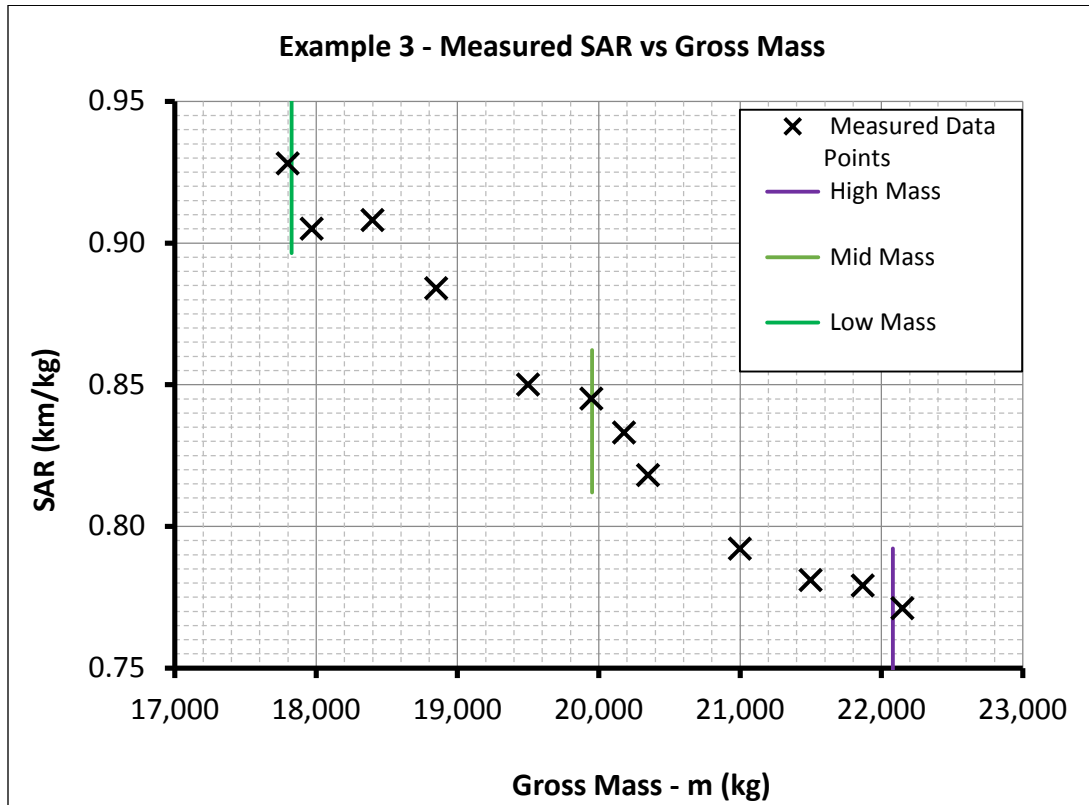

Figure 3.4-4 – Measured SAR vs Gross Mass – Example 3

Estimate of the mean SAR model by polynomial regression

In order to estimate the SAR model (SAR_{av}) as a function the aeroplane gross mass (m), a polynomial regression of second order is proposed, so that:

$$SAR_{av} = B_0 + B_1 m + B_2 m^2$$

Each observation (m_i, SAR_i), for $i = 1, \dots, 12$ satisfies the equation:

$$SAR_{(i)} = b_0 + b_1 m_i + b_2 m_i^2 + e_i$$

where e_i = residual error (difference between the measured SAR value and its estimate).

This gives under a matrix form:

$$\begin{pmatrix} SAR_1 \\ SAR_2 \\ SAR_3 \\ \vdots \\ SAR_{12} \end{pmatrix} = \begin{pmatrix} 1 & m_1 & m_1^2 \\ 1 & m_2 & m_2^2 \\ 1 & m_3 & m_3^2 \\ \vdots & \vdots & \vdots \\ 1 & m_{12} & m_{12}^2 \end{pmatrix} \begin{pmatrix} b_0 \\ b_1 \\ b_2 \end{pmatrix} + \begin{pmatrix} e_1 \\ e_2 \\ e_3 \\ \vdots \\ e_{12} \end{pmatrix}$$

$$\underline{SAR} = \underline{M} \underline{b} + \underline{e}$$

Where:

$$\underline{SAR} = \begin{pmatrix} 0.928 \\ 0.905 \\ 0.908 \\ 0.884 \\ 0.850 \\ 0.845 \\ 0.833 \\ 0.818 \\ 0.792 \\ 0.781 \\ 0.779 \\ 0.771 \end{pmatrix} \quad \underline{M} = \begin{pmatrix} 1 & 17800 & 17800^2 \\ 1 & 17970 & 17970^2 \\ 1 & 18400 & 18400^2 \\ 1 & 18850 & 18850^2 \\ 1 & 19500 & 19500^2 \\ 1 & 19950 & 19950^2 \\ 1 & 20180 & 20180^2 \\ 1 & 20350 & 20350^2 \\ 1 & 21000 & 21000^2 \\ 1 & 21500 & 21500^2 \\ 1 & 21870 & 21870^2 \\ 1 & 22150 & 22150^2 \end{pmatrix} \quad \underline{b} = \begin{pmatrix} b_0 \\ b_1 \\ b_2 \end{pmatrix} \quad \underline{e} = \begin{pmatrix} e_1 \\ e_2 \\ e_3 \\ \vdots \\ e_n \end{pmatrix}$$

The least square principle consists in looking for the parameter values of vector \underline{B} minimising the sum of the squares of residuals, i.e.:

$$\text{Min } \sum_{i=1}^{i=12} e_i^2 = \text{min } \sum_{i=1}^{i=12} (SAR_{(i)} - b_0 - b_1 m_i - b_2 m_i^2)^2$$

It is equivalent to look for the solutions of $\frac{\partial(\sum e_i^2)}{\partial b_j} = 0$ for $j = (0, 1, 2)$

The solution $\underline{B} = \begin{pmatrix} B_0 \\ B_1 \\ B_2 \end{pmatrix}$ is given by $\underline{A}^{-1} \underline{M}' \underline{SAR}$ (see §3.3.3), where:

- \underline{M}' = transpose of \underline{M}

- $\underline{A}^{-1} = (\underline{M}' \underline{M})^{-1}$ = Inverse of $(\underline{M}' \underline{M})$

Finally, $\underline{B} = \begin{pmatrix} 2.402921963 \\ -0.000120515 \\ 2.10695 \times 10^{-9} \end{pmatrix}$ and

$$SAR_{av} = 2.402921963 - 0.000120515 m + 2.10695 \cdot 10^{-9} m^2$$

The following figure 3.3-2 provides a representation of the mean SAR model as a function of the aeroplane gross mass:

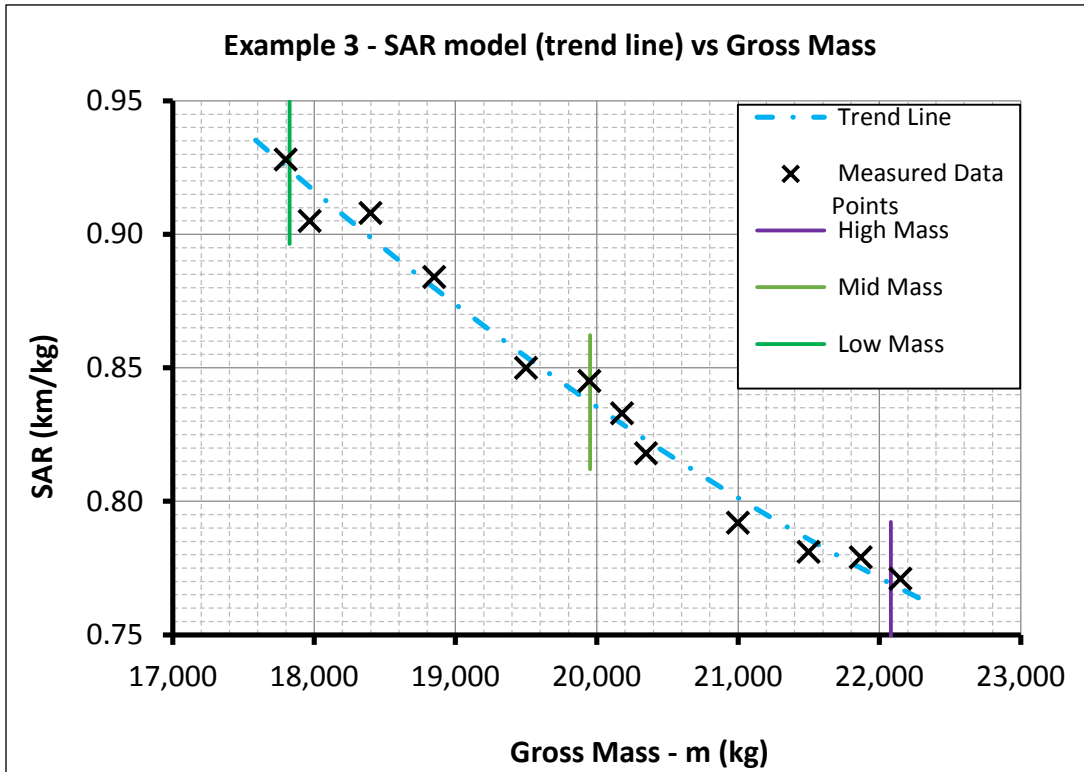

Figure 3.4-5 – SAR model (trend line) vs Gross Mass – Example 3

The mean SAR values at each of the three reference gross masses of the CO2 emissions evaluation metric are as follows:

<i>Reference mass</i>	<i>Mass value (kg)</i>	<i>Mean SAR value (km/kg)</i>
Low Mass	17825	0.92418
Mid Mass	19953	0.83710
High Mass	22080	0.76914

Table 3.3-5 – Mean SAR values – Example 3

Estimate of the standard deviation (s)

$$s = \sqrt{\frac{\sum_{i=1}^{i=n} (SAR_i - SAR_{av(i)})^2}{n-K-1}} = 0.00765 \text{ km/kg}$$

Where

- The number of data points (n) = 12
- K = 2 for a second order polynomial regression (See §3.3.3)
- The degrees of freedom (n-K-1) = 9

Confidence Interval determination

The 90 per cent confidence interval (CI_{90}) at an aeroplane gross mass m_0 is calculated as follows (see §3.3.3):

$$CI_{90} = SAR_{av}(m_0) \pm t_{(95, n-K-1)} s \sqrt{\underline{m_0} \underline{A}^{-1} \underline{m_0}'}$$

Where:

- The Student's t-distribution for 90 per cent confidence and 9 degrees of freedom $t_{(95, 9)} = 1.833$ (see Table 3.3-1).

- $\underline{m_0} = (1 \ m_0 \ m_0^2)$ and $\underline{m_0}' = \begin{pmatrix} 1 \\ m_0 \\ m_0^2 \end{pmatrix}$

- $\underline{A}^{-1} = (\underline{M}' \underline{M})^{-1}$ = Inverse of $(\underline{M}' \underline{M})$

The following figure 3.3-3 provides a representation of the 90% confidence interval as a function of aeroplane gross mass:

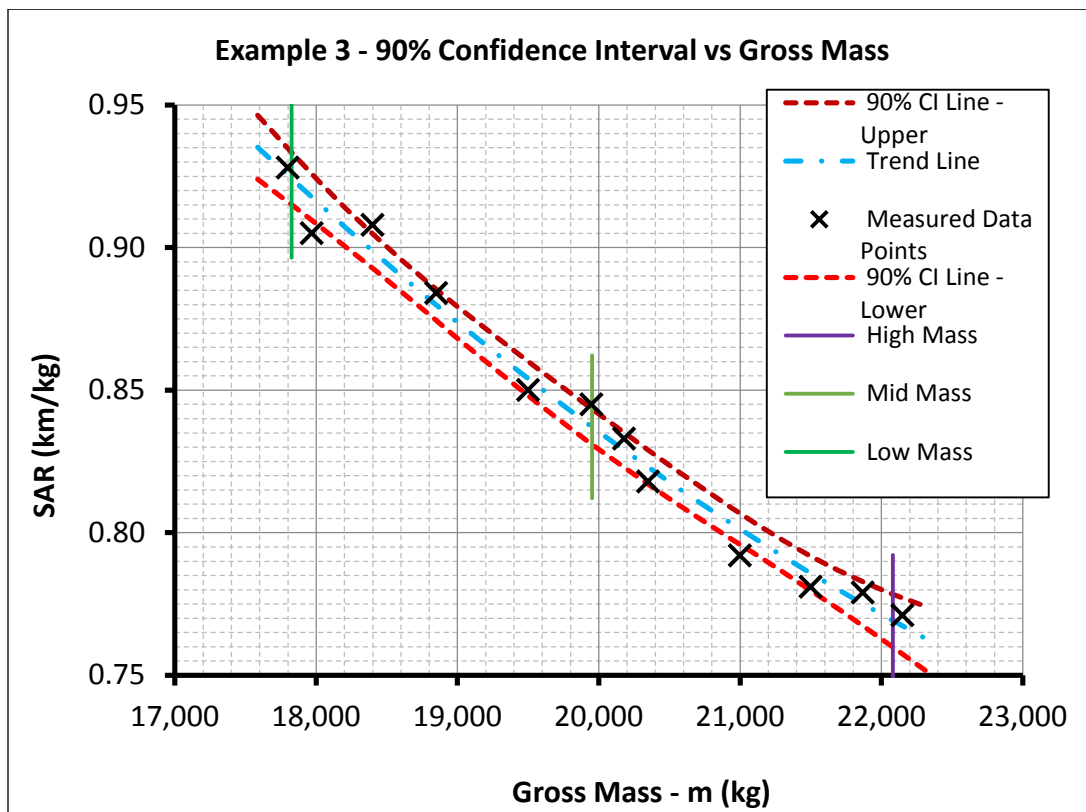

Figure 3.4-6 – 90% Confidence Interval vs Gross Mass – Example 3

The 90% confidence intervals at each of the three reference gross masses of the CO2 emissions evaluation metric are as follows:

Reference mass	Mass value (kg)	90% Confidence Interval (kg/km)
Low Mass	17825	$Cl_{90} = 0.92418 \pm 0.00915$
Mid Mass	19953	$Cl_{90} = 0.83710 \pm 0.00619$
High Mass	22080	$Cl_{90} = 0.76914 \pm 0.00925$

Table3.3-6 – Confidence intervals – Example 3

Check of confidence interval limits

For each of the three reference gross masses of the CO2 emissions evaluation metric, the confidence interval extends around the mean SAR value to an amount in percent provided in below table.

<i>Reference mass</i>	<i>Mass value (kg)</i>	<i>90% Confidence Interval (percentage of mean SAR)</i>
Low Mass	17825	$(0.00915/0.92418) \times 100 = 0.99\%$
Mid Mass	19953	$(0.00619/0.83710) \times 100 = 0.74\%$
High Mass	22080	$(0.00925/0.76914) \times 100 = 1.2\%$

Table 3.3-7 – Check of confidence intervals – Example 3

The 90 per cent Confidence Intervals at each of the three reference gross masses of the CO₂ emissions evaluation metric are all below the confidence interval limit of 1.5 per cent defined in Annex 16 Volume 3 Appendix 1 §6.4.

As a result, the following mean SAR values associated to each of the three reference masses of the CO₂ emissions evaluation metric can be used for the metric determination.

<i>Reference mass</i>	<i>Mass value (kg)</i>	<i>Mean SAR value (km/kg)</i>
Low Mass	17825	0.92418
Mid Mass	19953	0.83710
High Mass	22080	0.76914

Table 3.3-8 – Mean SAR values – Example 3

3.3.4.2.2 *Example 4: the Confidence Interval of at least one of the three reference masses of the CO₂ emissions evaluation metric exceeds the confidence interval limit*

Let's consider the following set of 12 measurements of SAR obtained by flight test at optimum speed and optimum altitude as a function of the aeroplane gross mass. After SAR correction to reference conditions, the following data set is obtained:

<i>Measurement Number & Reference Mass</i>	<i>Gross Mass (m_i) (kg)</i>	<i>Corrected SAR (SAR_i) (km/kg)</i>
1	17800	0.932
Low Mass ^(*)	17825	
2	18200	0.925
3	18620	0.913
4	18890	0.889
5	19350	0.868
6	19610	0.848
Mid Mass ^(*)	19953	
7	19920	0.838
8	20510	0.830
9	20790	0.806

Measurement Number & Reference Mass	Gross Mass (m_i) (kg)	Corrected SAR (SAR_i) (km/kg)
10	21220	0.815
11	21480	0.779
High Mass ^(*)	22080	
12	22100	0.788

Table 3.3-9 – Measurements of SAR – Example 4

^(*) Low, Mid and High mass represent the reference masses of the CO2 emissions evaluation metric defined in Annex 16, Volume 3, Chapter 2, §2.3.

The number of data points (n) = 12 (minimum requested by Appendix 1 of Annex 16 Volume 3, §6.3).

A representation of above measurement points is proposed in below figure 3.3-4.

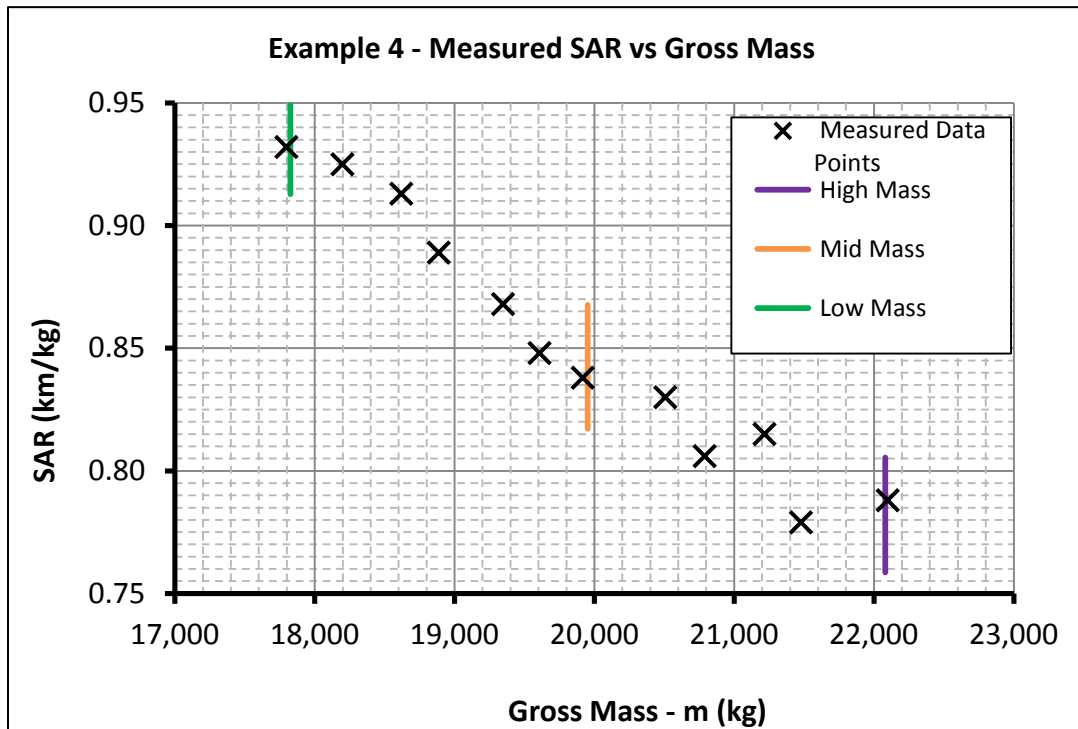

Figure 3.4-7 – Measured SAR vs Gross Mass – Example 4

Estimate of the mean SAR model by polynomial regression

In order to estimate the SAR model (SAR_{av}) as a function the aeroplane gross mass (m), a polynomial regression of second order is proposed, so that:

$$SAR_{av} = B_0 + B_1 m + B_2 m^2$$

Each observation (m_i, SAR_i), for $i = 1, \dots, 12$ satisfies the equation:

$$SAR_{(i)} = b_0 + b_1 m_i + b_2 m_i^2 + e_i$$

With e_i = residual error (difference between the measured SAR value and its estimate).

This gives under a matrix form:

$$\begin{pmatrix} SAR_1 \\ SAR_2 \\ SAR_3 \\ \vdots \\ SAR_{12} \end{pmatrix} = \begin{pmatrix} 1 & m_1 & m_1^2 \\ 1 & m_2 & m_2^2 \\ 1 & m_3 & m_3^2 \\ \vdots & \vdots & \vdots \\ 1 & m_{12} & m_{12}^2 \end{pmatrix} \begin{pmatrix} b_0 \\ b_1 \\ b_2 \end{pmatrix} + \begin{pmatrix} e_1 \\ e_2 \\ e_3 \\ \vdots \\ e_{12} \end{pmatrix}$$

$$\underline{SAR} = \underline{M} \underline{b} + \underline{e}$$

Where:

$$\underline{SAR} = \begin{pmatrix} 0.932 \\ 0.925 \\ 0.913 \\ 0.889 \\ 0.868 \\ 0.848 \\ 0.838 \\ 0.830 \\ 0.806 \\ 0.815 \\ 0.779 \\ 0.788 \end{pmatrix} \quad \underline{M} = \begin{pmatrix} 1 & 17800 & 17800^2 \\ 1 & 18200 & 18200^2 \\ 1 & 18620 & 18620^2 \\ 1 & 18890 & 18890^2 \\ 1 & 19350 & 19350^2 \\ 1 & 19610 & 19610^2 \\ 1 & 19920 & 19920^2 \\ 1 & 20510 & 20510^2 \\ 1 & 20790 & 20790^2 \\ 1 & 21220 & 21220^2 \\ 1 & 21480 & 21480^2 \\ 1 & 22100 & 22100^2 \end{pmatrix} \quad \underline{b} = \begin{pmatrix} b_0 \\ b_1 \\ b_2 \end{pmatrix} \quad \underline{e} = \begin{pmatrix} e_1 \\ e_2 \\ e_3 \\ \vdots \\ e_n \end{pmatrix}$$

The least square principle consists in looking for the parameter values of vector \underline{B} minimising the sum of the squares of residuals, i.e.:

$$\text{Min } \sum_{i=1}^{i=12} e_i^2 = \text{min } \sum_{i=1}^{i=12} (SAR_{(i)} - b_0 - b_1 m_i - b_2 m_i^2)^2$$

It is equivalent to look for the solutions of $\frac{\partial(\sum e_i^2)}{\partial b_j} = 0$ for $j = (0, 1, 2)$

The solution $\underline{B} = \begin{pmatrix} B_0 \\ B_1 \\ B_2 \end{pmatrix}$ is given by $\underline{A}^{-1} \underline{M}' \underline{SAR}$ (see §3.3.3), where:

\underline{M}' = transpose of \underline{M}

$\underline{A}^{-1} = (\underline{M}' \underline{M})^{-1}$ = Inverse of $(\underline{M}' \underline{M})$

Finally, $\underline{B} = \begin{pmatrix} 3.26727172 \\ -0.000205692 \\ 4.21798 \times 10^{-09} \end{pmatrix}$ and

$$SAR_{av} = 3.26727172 - 0.000205692 m + 4.21798 \cdot 10^{-9} m^2$$

The following figure 3.3-5 provides a representation of the mean SAR model as a function of the aeroplane gross mass:

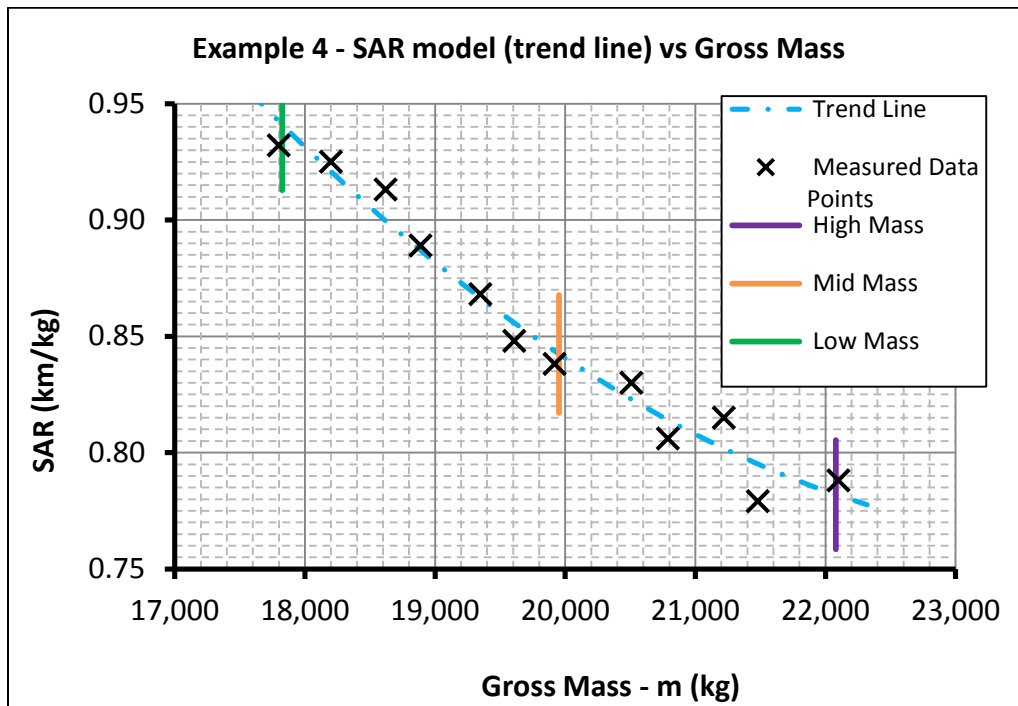

Figure 3.4-8 – SAR model (trend line) vs Gross Mass – Example 4

The mean SAR values at each of the three reference gross masses of the CO2 emission evaluation metric are as follows:

Reference mass	Mass value (kg)	Mean SAR value (km/kg)
Low Mass	17825	0.94100
Mid Mass	19953	0.84238
High Mass	22080	0.78198

Table 3.3-10 – Mean SAR value – Example 4

Estimate of the standard deviation (s)

$$s = \sqrt{\frac{\sum_{i=1}^n (SAR_i - SAR_{av(i)})^2}{n-K-1}} = 0.01050 \text{ km/kg}$$

Where

- The number of data points (n) = 12
- K = 2 for a second order polynomial regression (See §3.3.3)
- The degrees of freedom (n-K-1) = 9

Confidence Interval determination

The 90 per cent confidence interval (CI₉₀) at an aeroplane gross mass m₀ is calculated as follows (see §3.3.3):

$$CI_{90} = SAR_{av}(m_0) \pm t_{(.95, n-K-1)} s \sqrt{\underline{m}_0 \underline{A}^{-1} \underline{m}_0'}$$

Where:

- The Student's t-distribution for 90 per cent confidence and 9 degrees of freedom t_(.95, 9) = 1.833 (see Table 3.3-1).

- $\underline{m}_0 = (1 \ m_0 \ m_0^2)$ and $\underline{m}_0' = \begin{pmatrix} 1 \\ m_0 \\ m_0^2 \end{pmatrix}$

- $\underline{A}^{-1} = (\underline{M}' \underline{M})^{-1} = \text{Inverse of } (\underline{M}' \underline{M})$

The following figure 3.3-6 provides a representation of the 90% confidence interval as a function of aeroplane gross mass:

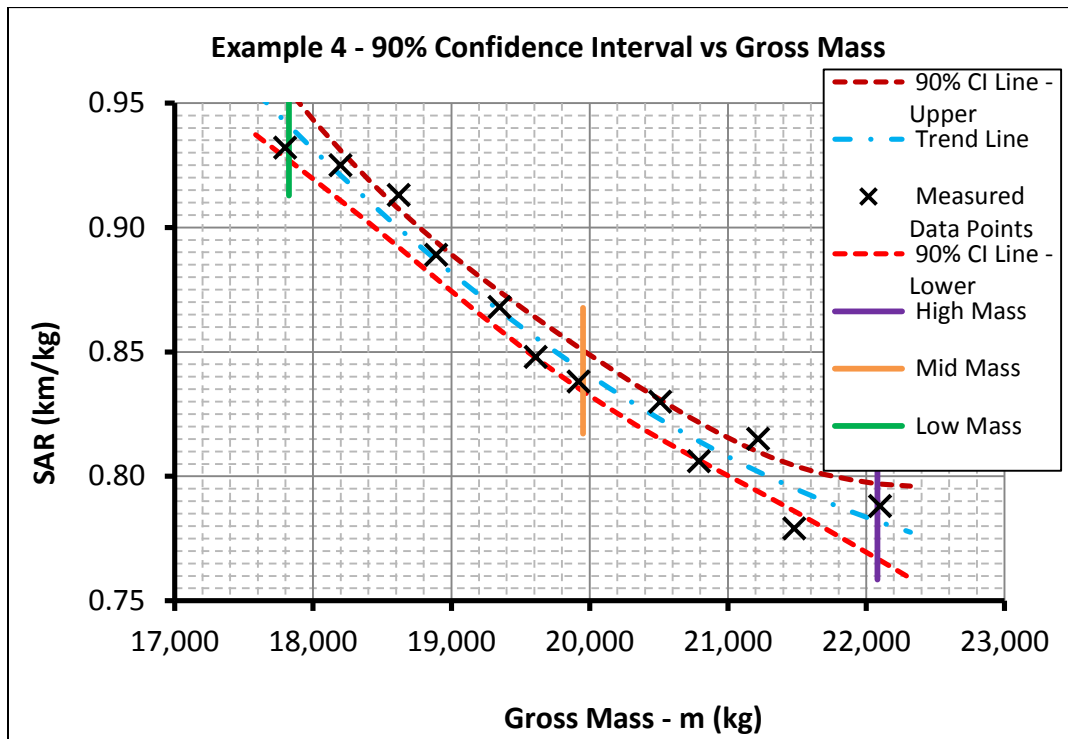

Figure 3.4-9 – 90% Confidence Interval vs Gross Mass – Example 4

The 90% confidence intervals at each of the three reference gross masses of the CO2 emissions evaluation metric are as follows:

Reference mass	Mass value (kg)	90% Confidence Interval (kg/km)
Low Mass	17825	$CI_{90} = 0.94100 \pm 0.01399$
Mid Mass	19953	$CI_{90} = 0.84238 \pm 0.00823$
High Mass	22080	$CI_{90} = 0.78198 \pm 0.01505$

Table 3.3-11 – Confidence intervals – Example 4

Check of confidence interval limits

For each of the three reference gross masses of the CO2 emissions evaluation metric, the confidence interval extends around the mean SAR value to an amount provided in below table.

Reference mass	Mass value (kg)	90% Confidence Interval (percentage of mean SAR)
Low Mass	17825	$(0.01399/0.94100) \times 100 = 1.52\%$
Mid Mass	19953	$(0.00823/0.84238) \times 100 = 0.98\%$
High Mass	22080	$(0.01505/0.78198) \times 100 = 1.93\%$

Table 3.3-12 – Check of confidence intervals – Example 4

The 90 per cent Confidence Intervals at the low and high reference gross masses of the CO₂ emissions evaluation metric are above the confidence interval limit of 1.5 per cent defined in Annex 16 Volume 3 Appendix 1 §6.4.

In such a case, a penalty equal to the amount that the 90 per cent confidence interval exceeds ± 1.5 per cent shall be applied to the mean SAR values as follows:

<i>Reference mass</i>	<i>Mass value (kg)</i>	<i>Corrected SAR value (km/kg)</i>
Low Mass	17825	$0.94100 \times [1 - (1.52-1.5)/100] = 0.94081$
High Mass	22080	$0.78198 \times [1 - (1.93-1.5)/100] = 0.77862$

Table 3.3-13 – Corrected SAR values – Example 4

As a result, the following mean SAR values associated to each of the three reference masses of the CO₂ emissions evaluation metric can be used for the metric determination.

<i>Reference mass</i>	<i>Mass value (kg)</i>	<i>Mean SAR value (km/kg)</i>
Low Mass	17825	0.94081
Mid Mass	19953	0.84238
High Mass	22080	0.77862

Table 3.3-14 – Mean SAR values – Example 4

3.4 EQUIVALENT PROCEDURES

3.4.1 *APPROVAL BASED ON EXISTING DATA*

3.4.1.1 The use of existing data as an equivalent procedure may be requested by applicants, and it can be utilized in the below approach of equivalent procedures or other approaches approved by the certifying authority according to their technical judgement.

- a) Develop a regression curve approach for SAR values across the gross weight (MTOM) range using existing data.

3.4.1.2 The information typically needed to use existing data for demonstrating compliance as an equivalent procedure is as follows:

- a) The existing model used company test data that was not witnessed by an authority and/or the aeroplane configuration was not conformed by an authority, but the data obtained is deemed acceptable by the certifying authority.
- b) The accuracy of the instrumentation and the data reduction processes may not have been documented to the quality standard desired for certification, or the original documentation may not have been retained, but the data available is deemed acceptable by the certifying authority.

3.4.2 *APPROVAL BASED ON BACK-TO-BACK TESTING*

3.4.2.1 The use of back-to-back test data may be requested by applicants as an equivalent procedure for determining the CO₂ evaluation metric value for relatively small configuration changes that can be made based on test data obtained on the same aeroplane with the same engines (e.g. antenna installations or other simple drag changes). This approach will typically not be appropriate for engine changes where the SFC of the engine may change due to internal changes. This compliance approach will likely be especially useful for STC modifiers who do not have access to the original flight test data from the aeroplane manufacturer.

- a) Back-to-back testing should be accomplished on the same aeroplane and engines with the modification installed and not installed.
- b) Instrumentation adequate to provide data meeting the accuracy requirements of the standard is installed in the test aeroplane.
- c) The data reduction and comparison processes are acceptable to the certifying authority.

3.4.3 *APPROVAL OF CHANGES BASED ON ANALYSIS*

3.4.3.1 The use of analytical processes to establish compliance with the CO₂ evaluation metric value criteria for changes to the CO₂ evaluation metric value of a previously approved aeroplane configuration may be requested by applicants, provided those processes are approved by the certifying authority according to their technical judgement.

- a) The data on which the analysis is based was derived from flight test data.
- b) Use of CFD and wind tunnel analyses may be acceptable if agreed to by the certifying authority.

Appendix 1 - REFERENCES

- ¹ ASTM International D1655-15 entitled "Standard Specification for Aviation Turbine Fuels". This ASTM International publication may be obtained from the ASTM International, 100 Barr Harbor Drive, PO Box C700, West Conshohocken, PA, 19428-2959 USA, www.astm.org.
- ² Defence Standard 91-91, Issue 7, Amendment 3, entitled "Turbine Fuel, Kerosene Type, Jet A-1". This Ministry of Defence Standard may be obtained from Defence Equipment and Support, UK Defence Standardization, Kentigern House, 65 Brown Street, Glasgow G2 8EX, UK.
- ³ ASTM International D4809-13 entitled "Standard Test Method for Heat of Combustion of Liquid Hydrocarbon Fuels by Bomb Calorimeter (Precision Method)". This ASTM International publication may be obtained from the ASTM International, 100 Barr Harbor Drive, PO Box C700, West Conshohocken, PA, 19428-2959 USA, www.astm.org.
- ⁴ ASTM International D4052-11 entitled "Standard Test Method for Density and Relative Density of Liquids by Digital Density Meter". This ASTM International publication may be obtained from the ASTM International, 100 Barr Harbor Drive, PO Box C700, West Conshohocken, PA, 19428-2959 USA, www.astm.org.
- ⁵ ASTM International D445-15 entitled "Standard Test Method for Kinematic Viscosity of Transparent and Opaque Liquids (and Calculation of Dynamic Viscosity)". This ASTM International publication may be obtained from the ASTM International, 100 Barr Harbor Drive, PO Box C700, West Conshohocken, PA, 19428-2959 USA, www.astm.org.

Appendix 2 - BIBLIOGRAPHY

1. Kendall, M.G. and A. Stuart. *The Advanced Theory of Statistics*. Volumes 1, 2 and 3. New York: Hafner, 1971.
2. Kendall, M.G. and G.U. Yule. *An Introduction to the Theory of Statistics*. 14th ed. New York: Griffin, 1950.
3. Snedecor, G.W. and W.G. Cochran. *Statistical Methods*. 6th ed. Arnes, Iowa: The Iowa State University Press, 1968.
4. Walpole, R.E. and R.H. Myers. *Probability and Statistics for Engineers and Scientists*. New York: MacMillan, 1972.
5. Wonnacott, T.H. and R.J. Wonnacott. *Introductory Statistics*, 5th ed. N.p.: John Wiley & Sons, 1990.

APPENDIX C
(English only)

**INFORMATION ON THE ICAO CO₂ STANDARD TO SUPPORT THE
RULEMAKING PROCESSES OF ICAO MEMBER STATES**

1. INTRODUCTION

1.1 The International Civil Aviation Organization (ICAO) is a United Nations (UN) specialized agency, established by States in 1944 to manage the administration and governance of the *Convention on International Civil Aviation* (referred to as the Chicago Convention). ICAO works with the Convention's 191 Member States and industry groups to reach consensus on international civil aviation Standards and Recommended Practices (SARPs) and policies in support of a safe, efficient, secure, economically sustainable and environmentally responsible civil aviation sector. Presently, there are over 10,000 such Standards and provisions contained in ICAO Annexes to the Chicago Convention. ICAO's ongoing mission is to support a global air transport network that meets or surpasses the social and economic development and broader connectivity needs of global businesses and passengers. While acknowledging the clear need to anticipate and manage the projected doubling of global air transport capacity by 2030 without unnecessary adverse impacts on system safety, efficiency, convenience or environmental performance, ICAO has established five comprehensive Strategic Objectives, namely: Safety, Air Navigation Capacity and Efficiency, Security and Facilitation, Economic Development of Air Transport, and Environmental Protection.

1.2 Improving the environmental performance of aviation is a challenge ICAO takes very seriously. In fulfilling its responsibilities, ICAO has three major environmental goals, which are to limit or reduce: 1) the number of people affected by significant aircraft noise, 2) the impact of aviation emissions on local air quality, and 3) the impact of aviation greenhouse gas emissions on the global climate. To limit or reduce the impact of aviation greenhouse gas emissions on the global climate, ICAO has identified a Basket of Measures with the aim of reducing carbon dioxide (CO₂) emissions from international aviation. The Basket of Measures includes solutions focused on technological improvements, operational improvements, sustainable alternative fuels and market-based measures (MBMs). Each measure will individually contribute to the overall effort to reduce CO₂ emissions from the air transport system.

1.3 The ICAO Committee on Aviation Environmental Protection (CAEP) is a technical committee of the ICAO Council established in 1983. CAEP assists the Council in formulating new policies and adopting new SARPs related to aircraft noise and emissions, and more generally to aviation environmental impacts. CAEP undertakes specific studies, as requested by the Council. Its scope of activities encompasses noise, air quality and the Basket of Measures considered for reducing international aviation CO₂ emissions. CAEP is structured into Working Groups in order to progress tasks under the various environmental areas (noise, emissions, modelling etc.).

1.4 Since 2010, CAEP has been developing an Aeroplane CO₂ Emissions Certification Standard, following the plan approved by the ICAO Council and the request from the 37th Session of the Assembly (Resolution A37-19⁹). This new Standard will be formed into a new Volume (Volume III) to Annex 16 to the *Convention on International Civil Aviation*, where Annex 16 Volume I covers aircraft noise and Volume II addresses aircraft engine emissions. The Aeroplane CO₂ Emission Certification

⁹ Doc 9958, Assembly Resolutions in Force (as of 8 October 2010), ISBN 978-92-9231-773-7, ICAO, 2011. The current Assembly resolutions in force are: Doc 10022, Assembly Resolutions in Force (as of 4 October 2013), ISBN 978-92-9249-419-3, ICAO, 2014

Standard, which is part of the Basket of Measures identified by the ICAO Assembly, focuses on reducing CO₂ emissions through the integration of fuel efficiency technologies into aeroplane type designs. In a similar way to the Annex 16, Volume I noise Standards, the CO₂ Standard is a technology standard focussed at the aeroplane level. The Standard is not aimed at reducing CO₂ emissions through operational measures, as these will be addressed by a different aspect of the Basket of Measures; however, it is underpinned by a certification requirement that is relevant to day-to-day operations, permits transport capability neutrality at a system level, and allows for equitable recognition of fuel efficiency improvement technologies in an aeroplane type design. Finally, the scope of applicability for a CO₂ standard should not include out-of-production nor in-service aeroplanes.

1.5 The CO₂ Standard has been developed considering the four core CAEP tenets, which are technical feasibility, environmental effectiveness, economic reasonableness, and the consideration of interdependencies (e.g. with noise and local air quality emissions). This has involved two phases of work which have focussed on the development of a certification requirement and options for a regulatory limit line. Figure 1 shows a representative framework of an ICAO Environmental Standard.

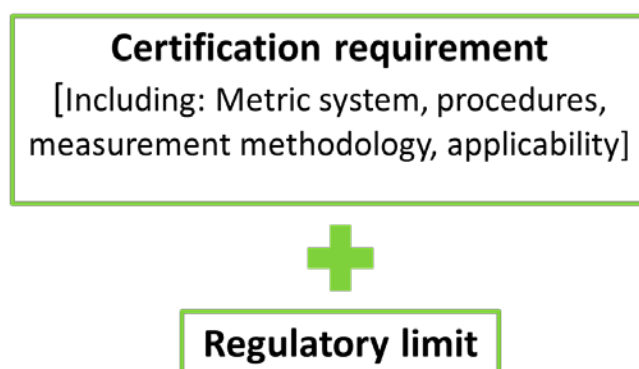

Figure 1: The basic framework of an ICAO Environmental Standard

1.6 Phase 1 involved tasks associated with the forming of a certification requirement for the CO₂ Standard, including the development of a CO₂ emissions evaluation metric system (i.e. metric/correlating parameter/test points), certification procedures, measurement methodologies, applicability to new aeroplane types, and initial inputs to the cost effectiveness assessment. Phase 2 included the development of ten regulatory limit stringency options (SOs), technology responses from the manufacturers when aeroplanes do not meet the SOs, a group of cost effectiveness analyses of the options available for the CO₂ Standard, interdependencies with noise and local air quality emissions, and an investigation of potential applicability to in-production aeroplanes. The text that follows provides a summary of the CO₂ Standard development work that has been conducted through a period of six years (i.e. two CAEP work cycles).

2. CAVEATS, LIMITATIONS AND CONTEXT OF THE INFORMATION

2.1 The data and information provided in this document were provided to support the selection of a CO₂ standard by ICAO CAEP in the context of the current ICAO Standard setting process. In particular, the assumptions on which the analysis is based uses current in-production and current project aircraft types (i.e. aeroplanes in development at the time of the analysis) as a baseline throughout the full analysis period (i.e. 2010-2040). They are not intended to be used for other purposes and should not be used as the basis to speculate on the introduction of potential future types. In addition, available

feasible technology is used as the basis for potential technology improvements resulting from the standard. The analysis does not speculate on potential future technology developments.

2.2 Assumptions of aeroplane technology responses to regulatory levels were based on input from both manufacturers and other expert sources. These responses were meant for CO₂ cost effectiveness modelling purposes, and do not imply a commitment from manufacturers to develop actual individual products.

2.3 As a consequence, the environmental benefits and the costs are comparable between analysis cases but cannot be represented as absolute benefits and costs. Hence the data and information are not suitable for application to any other purpose of any kind, and any attempt at such application would be in error.

3. ANNEX 16, VOLUME III AND THE ENVIRONMENTAL TECHNICAL MANUAL, VOLUME III

3.1 Overview of the CO₂ emissions evaluation metric

3.1.1 The provisions contained in the draft First Edition of Annex 16, Vol. III represent the SARPs for the certification of aeroplane CO₂ emissions based on the consumption of fuel. The certification requirements are underpinned by a CO₂ emissions evaluation metric, which is a measure of the aeroplane fuel burn performance and therefore the CO₂ emissions produced. The CO₂ emissions evaluation metric is made up of a metric, a correlating parameter and test points and it is shown in Table 1.

Metric ¹⁰	Correlating Parameter	Test Points
$= \frac{\left(\frac{1}{\text{SAR}}\right)_{\text{AVG}}}{(\text{RGF})^{0.24}}$	MTOM	Three test points with equal weighting at optimum conditions: i) High gross mass = 0.92 * MTOM ii) Mid gross mass = Average of high gross mass and low gross mass iii) Low gross mass = (0.45 × MTOM) + (0.63 × (MTOM ^{0.924}))

where:

SAR – Specific Air Range is the distance an aeroplane travels in the cruise flight phase per unit of fuel consumed.

RGF – Reference Geometric Factor is an adjustment factor based on a measurement of aeroplane fuselage size derived from a two-dimensional projection of the fuselage.

MTOM – Maximum Take-Off Mass is the highest of all take-off masses for the type design configuration.

Table 1: The CO₂ evaluation metric used within the CO₂ Standard

¹⁰ More details can be found in: ICAO Circular 337, CAEP/9 Agreed Certification Requirement for the Aeroplane CO₂ Emissions Standard, ISBN 978-92-9249-351-6

3.1.2 To establish the fuel efficiency of the aeroplane, the CO₂ emissions evaluation metric uses multiple test points to represent the fuel burn performance during cruise. Three equally weighted points represent aeroplane weights at high, middle and low percentages of MTOM, as specified in Table 1 and illustrated in Figure 2. Each of these points represents an aeroplane cruise gross weight which could be seen in service. The objective of using three gross weight cruise points is to make the evaluation of fuel burn performance more relevant to day-to-day aeroplane operations. The fuel efficiency performance of an aeroplane is represented by Specific Air Range (SAR), which represents the distance an aeroplane travels in the cruise flight phase per unit of fuel consumed. Within the CO₂ emissions evaluation metric, 1/SAR is used. Further details on its measurement and calculation can be found in the certification requirement contained within the proposed First Edition of Annex 16, Vol. III.

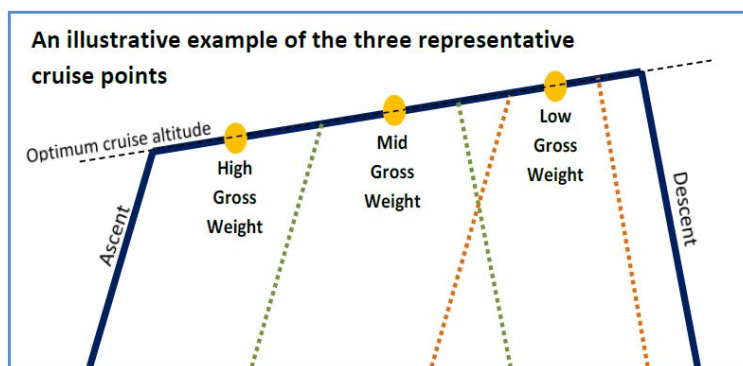

Figure 2: An illustrative example of the three representative certification test points

3.1.3 In some aeroplane designs, there are instances where changes in aeroplane size may not reflect changes in aeroplane weight, such as when an aeroplane is a stretched version of an existing aeroplane design. To better account for such instances, as well as the wide variety of aeroplane types and the technologies they employ, an adjustment factor was used to represent aeroplane size. This is defined as the Reference Geometric Factor (RGF) which is a measure of aeroplane fuselage size based on a two-dimensional projection of the fuselage. This improved the performance of the CO₂ emissions evaluation metric, making it better able to account for different aeroplane designs. The definition of RGF can be found in the certification requirement contained within the proposed First Edition of Annex 16, Vol. III.

3.1.4 The overall design of the aircraft is represented in the CO₂ emissions evaluation metric by the certified MTOM (the correlating parameter). This accounts for the majority of aircraft design features which allow an aircraft type to meet market demand.

3.1.5 The intent of the CO₂ emissions evaluation metric shown in Table 1 is to equitably reward advances in aeroplane technologies (i.e. structural, propulsion and aerodynamic) that contribute to reductions in aeroplane CO₂ emissions, and to differentiate between aeroplanes with different generations of these technologies. As well as accommodating the full range of technologies and designs which manufacturers can employ to reduce CO₂ emissions, the metric has been designed to be common across different aeroplane categories, regardless of aeroplane purpose or capability. The CO₂ emissions evaluation metric was developed based on data for in-production and out of production aeroplane types. A set of key criteria was followed during the development of the CO₂ emissions evaluation metric:

- General. The certification standard must not compromise safety levels. The CO₂ certification requirement should be aeroplane performance-based, should reflect CO₂ emissions at the aeroplane level. It should also allow for the differentiation of products with different

generations of CO₂ reduction technologies and should aim to be independent of aeroplane purpose or utilization. The certification requirement should decouple effects of fuel performance from aeroplane performance;

- **Effective.** Improvements observed via the CO₂ certification requirement should correlate with reduction of CO₂ emissions at the aeroplane level as demonstrated by procedures which are relevant to day-to-day operations. It should also take into account fundamental aeroplane design elements and capabilities (such as distance travelled and what is transported);
- **Objective.** The certification requirement should be objective and therefore needs to be based on certified aeroplane parameters and/or currently non-certified parameters as long as the parameters that compose the metric are easily measurable at the certification stage, or derived from engineering data. The certification requirement should consider the industry standard practices of measurement and adjustment;
- **Robust.** The metric should be robust in order to minimise the potential for unintended system and aeroplane design consequences, to limit interdependencies and to limit any influence on other standards. To the extent practicable, the certification requirement should be fair across the set of stakeholders, such as manufacturers and operators;
- **Reasonable.** The certification requirement should not require an inappropriate level of resources on the part of National Airworthiness Authorities and manufacturers to implement. If the certification requirement requires the certification of additional parameter(s) compared to existing practices, the implications (such as technical feasibility and economic reasonableness) should be evaluated; and
- **Open.** The output should be explainable to the general public.

3.1.6 The discussions on an appropriate CO₂ emissions evaluation metric were also guided by a set of high level principles, namely:

- 1) Within the Basket of Measures, an aircraft CO₂ standard should focus on reducing CO₂ emissions through integration of fuel efficiency technologies into aeroplane type designs.
- 2) Aim to design a metric system (metric/correlating parameter/test points) which could permit transport capability neutrality at a system level when stringency is applied based on this metric system.
- 3) Aim for equitable recognition of fuel efficiency improvement technologies in an aircraft type design.

3.2 The Certification Requirement

3.2.1 Based on the agreed CO₂ emissions evaluation metric, CAEP developed procedures for the certification requirement including, *inter alia*, SAR flight test and measurement conditions; the measurement of SAR and corrections to reference conditions; and the definition of the RGF used in the CO₂ emissions metric. CAEP established and utilized a Certification Experts (CE) group to support the discussions on the certification requirement and to facilitate oversight of commercially sensitive information. The CE group identified the manufacturers' existing practices in measuring aircraft fuel burn and high speed performance in order to understand how current practices could be used and built upon. Based on this information, a draft proposed ICAO Annex 16, Volume III CO₂ Standard certification requirement was developed, and this was approved by the CAEP/9 meeting in February 2013 as documented in ICAO Circular 337. Following this, the certification procedures were further developed to reinforce the requirements within the proposed Volume III and ensure a smooth implementation in Type Certification projects once adopted by ICAO and Member States. The topics covered during the development of the CO₂ Standard certification requirement included: stability criteria and confidence intervals; methodologies to correct test data to reference conditions; extrapolation of data; fuel used in

SAR flight tests; verifying test aeroplane mass determination; demonstrating nominal operating values for power extraction; RGF for unpressurized aeroplanes; numerical model confidence intervals; and correction of engine fuel efficiency performance.

3.3 **The Environmental Technical Manual (ETM), Volume III**

3.3.1 An Environmental Technical Manual, Vol. III (ETM, Vol. III) has also been developed with the aim of promoting uniformity of implementation of the technical procedures of Annex 16, Volume III by providing: (1) guidance to certificating authorities, applicants and other interested parties regarding the intended meaning and stringency of the Standards in the current edition of the Annex; (2) guidance on specific methods that are deemed acceptable in demonstrating compliance with those Standards; and (3) equivalent procedures resulting in effectively the same CO₂ emissions evaluation metric that may be used in lieu of the procedures specified in those Standards.

4. **STRINGENCY OPTIONS (SOs)**

4.1 An important part of the Standard-setting process was the definition of a set of SOs, which could be chosen to represent the eventual limit line for the CO₂ Standard. Each SO aimed to maintain the intended behaviour of the CO₂ emissions metric, i.e. to equitably reward advances in aeroplane technologies that contribute to reductions in aeroplane CO₂ emissions, and to differentiate between aeroplanes with different generations of these technologies.

4.2 Unlike other recent CAEP Standard-setting processes that led to more stringent regulatory levels to an existing standard, the CO₂ Standard work had no baseline in the form of an existing regulatory level or a proposed range of stringency options to assess. In addition, applicability scenarios for new aeroplane types (NT) and new deliveries of in-production (InP¹¹) aeroplane types were also considered and so the underlying production assumptions to be used in the cost-effectiveness assessment were also uncertain. As a consequence, a preliminary analysis framework was developed, and this helped to form an initial wide analytical space that included all InP and in-development project aeroplane types. The analytical work to define the wide analytical space, and the set of SOs across contained within it, necessarily considered the impact of SOs on the InP and in-development project aeroplane types. The selection of the SOs formed a fundamental part of the cost-effectiveness analysis and as such the set of ten SOs were carefully selected so as not to pre-judge the outcome of this analysis.

4.3 As with other ICAO environmental standards, the shape of the limit line is important to capture the differences in technology across the spread of aeroplane types. Discussions on appropriate SO curve shapes within the wide analytical space involved assessing equivalent levels of fuel efficient technology between aeroplane types at different MTOMs. Technical and economic limitations in adopting fuel efficiency technologies within different aeroplane categories were also recognised.

4.4 The analysis to develop the ten CO₂ SOs was based on several extensive CO₂ metric value databases. The Metric Value database (MVdb) contained uncertified data provided directly from manufacturers on in-production aeroplane types, and the Project Aircraft Metric Value database (PAMVdb) contained performance estimates for in-development project aeroplane types provided directly by either the manufacturers or other entities. The CO₂ SOs were generated as percentage offsets at 60 tonnes (t) maximum take-off mass (MTOM) to an Adapted Reference Line (ARL) datum that passed through the worst performing (in terms of CO₂ emissions metric) of the in-production aeroplanes. The

¹¹ InP refers to those aeroplane types which have already applied for a Type Certificate before the applicability date of the new type CO₂ Standard, and for which manufacturers either have existing undelivered sales orders or would be willing and able to accept new sales orders.

percentage offsets were made at 60t MTOM because this represents a “kink point” in the SO lines between the largest of the “smaller” aeroplanes and the smallest of the “larger” aeroplanes.

4.5 Locating the kink point at 60t MTOM acknowledges observed differences in behaviour between the “smaller” aeroplanes and the “larger” aeroplanes, and takes into account the latest single aisle and regional jet data which has become available since the end of the CAEP/9 meeting in February 2013. The 60t kink point was found to be the optimal place to split the new small aeroplane entries from Bombardier, Embraer, and Mitsubishi from the larger aeroplanes built by Boeing, Airbus, and other manufacturers. It falls below the large aeroplane weight variants and above all but one of the small aeroplane variants. The 60t kink in the CO₂ SOs is designed to produce a continuous stringency line that minimizes market distortions.

4.6 In order to accommodate potential future Type Certificate applications above the highest MTOM within the current fleet of InP and in-development aeroplanes (i.e. the highest MTOM was 600t in the CO₂ MVdb and PAMVdb), the CO₂ SO curve shape has been extrapolated above the 60t kink towards infinity. This aims to avoid potential ambiguity and delays in future type certification projects by ensuring there is an associated regulatory CO₂ limit line for aeroplanes with an MTOM above 600t. The lack of data above 600t MTOM on which to base the curve extrapolation is certainly a concern, and it is envisaged that this issue will be considered during future CAEP work programmes if the industry aims to manufacture aeroplanes above 600t MTOM.

4.7 The choice to have ten SOs was based on an analysis of impact rates across the fleet of aeroplane types, and this is shown in Table 2 across all the seat classes, along with margins to the ARL for all InP and project aircraft types. This means that the percentage differences between SOs is not constant because the analysis was conducted so that the SOs would impact the full scope of InP and project aeroplanes as the SOs become more stringent. For project aeroplanes, the data used included a level of uncertainty over a range of metric values that represented the type design under development. For the purposes of the analysis, the upper point (i.e. the worst case combination of highest metric value with lowest MTOM) was used for determining pass/fail compliance and therefore the impact rate of the SOs. The ten SOs provided a convenient analytical space within which to conduct a full cost effectiveness analysis, but had no particular meaning with regards to the stringency ultimately chosen as the regulatory limit line.

CO ₂ Stringency Option	% to ARL at 60t MTOM	MV at 60t MTOM	Impact Rate
1	- 20.0%	0.8734	7%
2	- 24.0%	0.8297	13%
3	- 27.0%	0.7970	24%
4	- 28.5%	0.7806	32%
5	- 30.0%	0.7642	41%
6	- 31.5%	0.7479	50%
7	- 33.0%	0.7315	57%
8	- 34.3%	0.7173	60%
9	- 37.5%	0.6823	79%
10	- 40.4%	0.6507	99%

Table 2: The ten SOs and the impact rate across the fleet of aeroplane types

4.8 Figures 3 and 4 show the ten SOs resulting from the CAEP analysis. The ten SOs provide a data driven measurement of fuel efficiency performance from aeroplane technology and design within the full range of MTOM, seeking as far as practicable to apply approximately equal pressure across aeroplane categories.

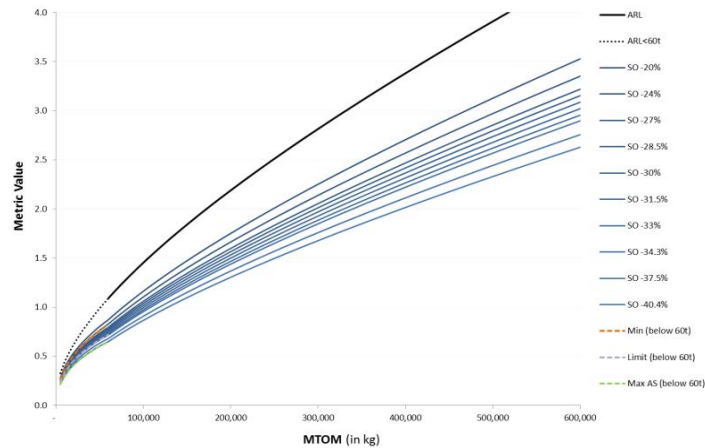

Figure 3: CO₂ stringency options analysed within the cost effectiveness analysis (0-600t MTOM)

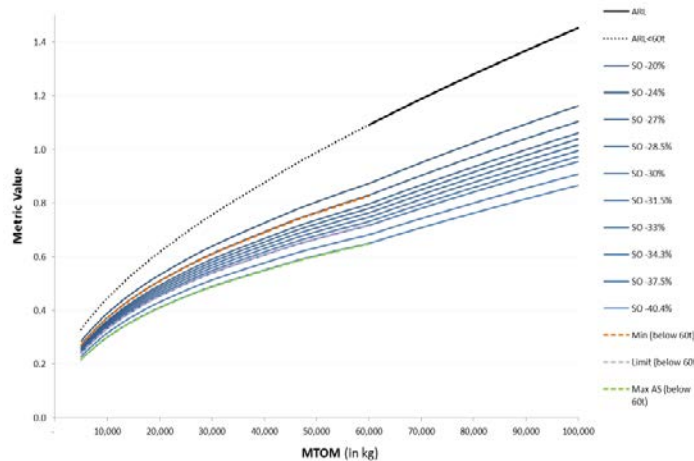

Figure 4: CO₂ stringency options analysed within the cost effectiveness analysis (0-100t MTOM)

5. MODELLING APPROACH FOR THE COST EFFECTIVENESS ANALYSIS

5.1 In order to address the CAEP tenets of environmental effectiveness and economic reasonableness, CAEP has conducted a full cost effectiveness analysis. This involved the definition of an analysis framework and analytical tools, including fleet evolution modelling, environmental modelling, recurring costs, non-recurring costs, costs per metric tonne of CO₂ avoided, certification costs, hybrid applicability and sensitivity tests. The analysis framework has allowed CAEP to conduct the CO₂ main analysis (CO₂ma), with the aim of providing a reasonable assessment of the economic costs and environmental benefits for a potential CO₂ standard in comparison with a “No ICAO action” baseline. A high level overview of the CO₂ma process is provided in Figure 5. An overview of the models used is contained in Table 3.

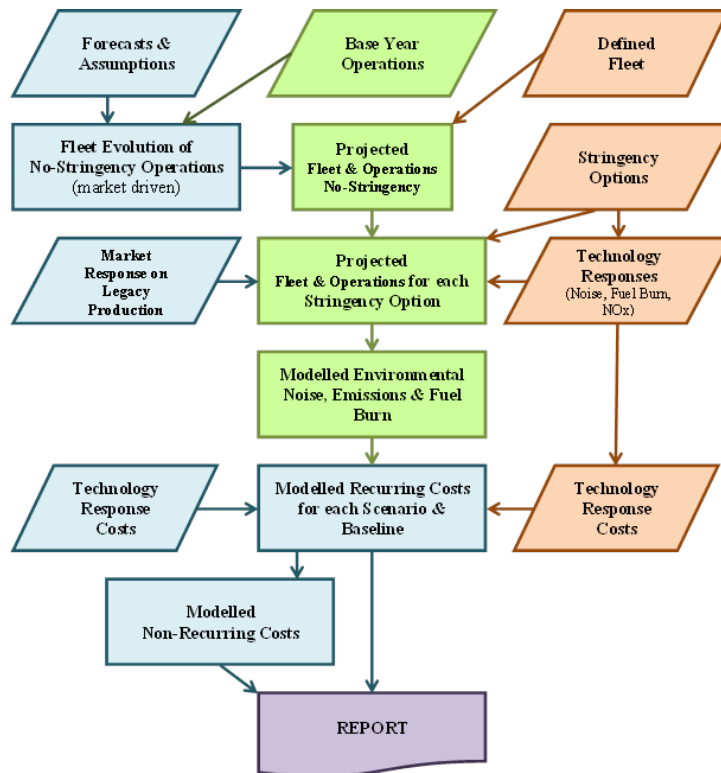

Figure 5: An overview of the CO₂ Main Analysis Framework and Processes

Model		Area	Sponsor
AAT	Aircraft Assignment Tool	Fleet Evolution	EUROCONTROL, EC and EASA
APMT-E	Aviation environmental Portfolio Management Tool for Economics ¹²	Fleet Evolution & Cost-Effectiveness	US
FCM	FESG Cost Model for the CO ₂ ma	Cost-Effectiveness	ICAO/CAEP FESG ¹³
FAST	Future Civil Aviation Scenario Software Tool ¹⁴	GHG	UK
IMPACT	Multi-airport environmental impact assessments tool for noise, gaseous and particulate emissions, and local air quality modelling ¹⁵	GHG	EUROCONTROL
AEDT	Aviation Environmental Design Tool ¹⁶	GHG and Noise	US
ANCON	Aircraft Noise Contour Model ¹⁷	Noise	UK
STAPES	SysTem for AirPort noise Exposure Studies ¹⁸	Noise	EUROCONTROL, EC and EASA

Table 3: An overview of the models used in the CO₂ Main Analysis (CO₂ma)

5.2 Defining the global aeroplane fleet

5.2.1 The modelling process relies on aeroplanes available for entry into the global aeroplane fleet during forecast years up to 2040, for both the baseline and each of the ten SOs. The aeroplane data are collated into what is known as the Growth and Replacement (G&R) database. This database documents all of the information required by the modelling community regarding each aeroplane and engine type in the analysis, both in their base configuration and as defined for each SO. The G&R database also includes references to other data sources such as the ICAO Aircraft Engine Emissions Databank and the ICAO noise certification database (NoisedB).

5.2.2 The CO₂ma G&R database fleet includes project aeroplanes that enter the fleet from 2014 to 2020. Some aeroplanes are described as having a “transition pair” where project aeroplanes are paired with current InP aeroplanes that transition out of the fleet as the project aeroplanes transition into the fleet. These Transition Pairs (TP) approximate a “ramp up/ramp down” of production for the two aeroplane types of a period of 6 years (this is described further in Section 6). If transitioning-out types are still available for growth and replacement after the implementation date of a CO₂ Standard, then their technology relationship to the SOs is taken into account. In other words, if an InP aeroplane with a TP passes a given SO then it continues to transition as it would have. However, if it were to not pass a given SO then the current InP aeroplane would go out of production earlier and the transition to the project aircraft could happen immediately upon implementation of the CO₂ Standard if that aeroplane were available for deployment.

¹² https://www.faa.gov/about/office_org/headquarters_offices/apl/research/models/apmt/

¹³ ICAO/CAEP Forecast and Economic Analysis Support Group (FESG)

¹⁴ <http://www.cate.mmu.ac.uk/about-us/how-we-do-it/climate-models-and-tools/emissions-models/>

¹⁵ <http://www.eurocontrol.int/services/impact>

¹⁶ https://www.faa.gov/about/office_org/headquarters_offices/apl/research/models/aedt/

¹⁷ <http://publicapps.caa.co.uk/modalapplication.aspx?catid=1&pagetype=65&appid=11&mode=detail&id=784>

¹⁸ https://www.eurocontrol.int/eec/public/standard_page/proj_STAPES.html

5.3 Fleet evolution modelling

5.3.1 Using the G&R database fleet, the fleet evolution models use air traffic forecasts to project a schedule of operations by specific aircraft types, and generate required inputs for the environmental models. The EUROCONTROL, European Commission (EC) and European Aviation Safety Agency (EASA) Aircraft Assignment Tool (AAT) and the U.S. Federal Aviation Administration (FAA) Aviation environmental Portfolio Management Tool for Economics (APMT-E) modelled the fleet evolution for the CO₂ma.

5.3.2 The underlying forecast targets input into the fleet evolution models, and their relative allotment to the Competition Bins (Cbin)¹⁹, have an important influence on the CO₂ma results. CBins are a method to describe different segments of the fleet without the need to specify demand for specific aeroplane types. Table 5 describes how these bins are divided across the fleet.

	Seat Range and Aircraft Type	MTOM (tonne)
CBin-1	Business Jets (BJ): <20seats, Cabin 300-700cft & Range 1700 to 3100 nm	6.3 to 13.9
CBin-2	BJ: <20seats, Cabin 700-1500cft & Range 3100 to 5000 nm	16.4 to 24.3
CBin-3	BJ: <20seats, Cabin 1500-3000cft & Range over 5000 nm	31.8 to 45.2
CBin-4	BJ: <20seats, Large Corporate Jets	68.0 to 80.6
CBin-5	20-70 seat Turboprops	18.6 to 28.4
CBin-6	71-100 seat Turboprops	29.6
CBin-7	20-70 seat Regional Jets	20.0 to 43.7
CBin-8	71-100 seat Regional Jets	38.3 to 56.2
CBin-9	101-150 seats	52.3 to 107.5
CBin-10	151-210 seats	74.3 to 110.8
CBin-11	211-300 seats	186.9 to 347.8
CBin-12	301-400 seats	248.4 to 351.5
CBin-13	401-600 seats	447.7 to 575.0
CBin-14	New Purpose-Built Freighters equivalent to 211-300 seats	107.5 to 233.0
CBin-15	New Purpose-Built Freighters equivalent to 301 seats and up	347.8 to 447.7

Table 4: Aeroplane Competition Bins (CBins), Seat Ranges, and MTOMs

5.3.3 The left side of Table 5 shows the distribution of baseline operations by CBin; and, combined CBin-9 and CBin-10 represent approximately 50% of total operations. The right side of Table 5 shows the distribution of available seat kilometres (ASKs) by CBin. Around 93% of ASKs (and around 69% of operations) in 2040 are from five CBins (9, 10, 11, 12 & 13), which means that these CBins will have a more pronounced effect on the CO₂ma results.

¹⁹ A Competition Bin or CBin is aligned to the forecasted seat classes, either one-to-one or in combination (e.g., seat classes for aircraft above 401 seats were combined into CBin-13).

	2020 Ops	2030 Ops	2040 Ops	Avg. Seats	2020 ASK	2030 ASK	2040 ASK
CBin-1	4.3%	4.0%	4.0%	13	0.3%	0.3%	0.2%
CBin-2	2.3%	2.4%	2.6%	13	0.3%	0.3%	0.2%
CBin-3	0.9%	1.2%	1.6%	13	0.2%	0.2%	0.3%
CBin-4	0.0%	0.0%	0.0%	13	0.0%	0.0%	0.0%
CBin-5	10.9%	10.5%	10.0%	55	0.9%	0.9%	0.8%
CBin-6	1.2%	1.2%	1.2%	74	0.2%	0.1%	0.1%
CBin-7	8.1%	6.7%	5.8%	55	1.4%	1.2%	1.0%
CBin-8	6.2%	5.9%	5.9%	86	2.0%	1.8%	1.6%
CBin-9	26.8%	25.1%	22.8%	126	16.7%	14.5%	12.3%
CBin-10	28.8%	28.1%	26.8%	171	28.2%	25.8%	23.2%
CBin-11	6.4%	9.3%	10.6%	261	25.1%	26.2%	24.2%
CBin-12	2.5%	3.1%	4.4%	332	13.9%	13.7%	15.3%
CBin-13	1.1%	2.2%	4.0%	484	8.6%	13.2%	18.9%
CBin-14	0.2%	0.1%	0.2%	220	0.3%	0.2%	0.3%
CBin-15	0.3%	0.3%	0.3%	368	1.9%	1.6%	1.6%

Table 5: Baseline Operations (Ops) and ASK Distribution by Competition Bin (Cbins) and Forecast Year

5.3.4 The CO₂ma fleet evolution modelled by APMT-E was used to generate the Fleet Evolution Output Database (FEOD) that was provided as input for all GHG and noise modellers. In addition, GHG results associated with the fleet evolution modelled by AAT were calculated using the EUROCONTROL IMPACT tool. Overall, the fleet evolution models produced consistent aggregate output metrics for the CO₂ma baseline run and consistent interpretation of the CO₂ma stringency option responses. While there are differences between the models when calculating market shares and deploying aircraft that result in some variation in operations, flight kilometres and aircraft deliveries²⁰ at the CBin level, there is good alignment between the models in terms of the direction and magnitude of the CBin level changes between the baseline and SO scenarios.

5.4 Environmental modelling tools

5.4.1 Full-flight fuel burn and NO_x emissions were modelled using AEDT (USA), FAST (UK) and IMPACT (EUROCONTROL) for analysis years 2010, 2020, 2030 and 2040. It is important to understand that the tools model fuel burn and performance differently.

5.4.2 AEDT models all aircraft performance using a total of 111 unique aircraft from ICAO/ Aircraft Noise and Performance (ANP)²¹ Version 3.0 database (up to 10,000 feet for fuel burn and 15,000 feet for noise) and 62 unique aircraft from the “Base of Aircraft Data” (BADA) version 4.1 and 37 unique aircrafts from version 3.12 (above 10,000 feet for fuel burn). Fuel burn computations are based on the output of the performance model and, nominally, the BADA fuel flow coefficients²².

²⁰ For example; when deploying aeroplanes AAT uses an equal distribution across forecast distance bands while APMT-E deploys aeroplanes according to the base year distribution; and, when calculating SO market shares in the aeroplane choice model, APMT-E adjusts fuel burn rates and costs to reflect the aircraft-specific TR for each SO.

²¹ ANP – Aircraft Noise and Performance database

²² BADA is a database developed by EUROCONTROL to estimate aeroplane fuel usage and was used by AEDT and IMPACT.

5.4.3 FAST is a global three-dimension (longitude, latitude and altitude) aviation inventory and scenario modelling platform that uses aircraft movement inputs and PIANO²³ fuel usage to generate fuel, CO₂, NO_x, CO, particles, soot and distance flown.

5.4.4 The IMPACT model is a successor to the CAEP-approved Advanced Emissions Model (AEM) for the assessment of fuel burn and CO₂ emissions. IMPACT is a web-based environmental modelling system developed by EUROCONTROL in the context of the Single European Sky Air Traffic Management Research (SESAR) collaborative project. It allows the consistent assessment of trade-offs between noise and gaseous emissions owing to a common aircraft performance model based on a combination of the ICAO/ANP database and the latest release of BADA 4. IMPACT has successfully contributed to the GHG assessments of the CO₂ma.

5.5 Environmental Modelling Framework

5.5.1 The CO₂ma framework was initially defined as a series of four cases that could consider CO₂ standard application to new types (NT) and new deliveries of InP types²⁴. The framework also provided for the assessment of something other than implementation of all technically feasible responses or assuming that aeroplanes go out of production at the implementation date(s) if they cannot be made compliant to an SO level. The “Case” terminology remains since it reflects terminology used during the work of CAEP on the development of the CO₂ Standard; however, there are no longer a full sequence of Cases. Rather, the three following cases were taken forward to support the standard setting process.

5.5.2 **NT and InP aeroplane applicability case - Full Technology Response (TR) / Out of Production Case (Case-1):** This involved the analysis of the ten SOs at the agreed implementation dates²⁵, using all technology responses²⁶ defined by CAEP, and with aeroplanes that are assumed to go out of production (OoP) at the implementation dates if they cannot be made compliant to a stringency option level²⁷.

5.5.3 **NT-Only applicability case - Alternative Response / Production Case (Case-4):** This involved the analysis of the ten SOs at agreed implementation dates for NT-only applicability using responses informed by market considerations since manufacturers would not have a legal deadline to bring InP types to levels required under a NT-only standard. This case, called Case 4, can be thought of as a range of response scenarios from a voluntary response similar to Case-1 down to an absence of any response by growth and replacement aircraft; and, within that range, Case-4 was summarized in the following sub-cases as follows:

- Case-4-A: Top 33% most likely families respond and non-compliant families go out of production, unless no aircraft types remain to meet distance band demand;
- Case-4-B: Repeat Case-4-A with the B767 family remaining in production without a TR; and
- Case-4-C: Top 33% most likely families respond and non-compliant families remain in production.

²³ PIANO is a commercially available software program that allows for the calculation of full flight fuel estimates from a variety of aircraft and was used by FAST.

²⁴ It was agreed at the CAEP/9 meeting, that the scope of applicability for a CO₂ standard should include new aeroplane types, but not out-of-production, and that applicability to InP types should not be ruled out; applicability to in-service aeroplanes was ruled out.

²⁵ As agreed at CAEP/9, the implementation dates for the CO₂ Standard Stringency assessment are 2020 and 2023; and, subsequently additional sensitivity analyses were performed for 2025 and 2028 applicability dates.

²⁶ described below in Section 6

²⁷ The OoP assumption was referred to as the “Market Driven Production Cut-off” when used in previous CAEP analyses.

5.5.4 It was agreed by CAEP members that modelling should proceed for Case 1 and Case-4c; and, Cases 4a and b could be analysed if time and resources permit. The technology response to these cases is described in Section 6.

5.5.5 A **Hybrid Applicability case** was also investigated. This involved the application of the CO₂ standard to NT aeroplanes prior to new deliveries of InP types that allows for potentially combining a higher SO for NT applicability with a lower SO for InP applicability.

5.6 Cost modelling

5.6.1 The recurring direct operating costs (DOC) include: (a) capital costs (including finance and depreciation), (b) other-DOC (including crew, maintenance landing and route costs) and (c) fuel costs. The primary model used for modelling other-DOC and capital costs was APMT-E; and fuel costs were based on AEDT fuel burn data. The ICAO/CAEP FESG Cost Model (FCM) was used to confirm the results using both AAT and APMT-E fleet evolution data along with AEDT fuel burn data.

5.6.2 As there is no existing CO₂ Standard, there is no historic data on fleet valuation impacts on aircraft owner/operators or on how manufacturers will determine the technology response given changes in market demand associated with CO₂ regulatory levels. Consistent with standard principles of economic analysis, all relevant recurring and non-recurring cost (NRC) items should be accounted for in the cost analysis of the CO₂ Standard SOs. Among these cost items, non-recurring (N-R) aircraft owner/operator (AO/O) costs may include a loss in fleet value that could be incurred by aircraft owners and operators for fleet assets that would not meet the stringency options; referred to as asset value loss (AVL). This is based on the premise that the introduction of a new standard would reduce the market value of existing fleets that do not meet the standard, even if the standard does not apply to the in-service aircraft. Further details on the NRC assumptions can be found in Section 6.

5.6.3 It should be noted that CAEP has not definitively stated whether AVL costs should be included and therefore the results of the CO₂ma were considered with and without AVL.

5.6.4 The CO₂ma uses NRC to represent the cost of applying TRs to aircraft. It is understood, however, that while NRC capture the fixed cost associated with developing TRs applied to aircraft types so that they pass the standard, they do not reflect additional production cost of implementing these responses, i.e., material, labour and other recurring costs. The CO₂ma assumes that the cost of manufacturing aeroplanes remains unchanged after they have been modified to meet an SO, whereas the additional technology contained in a technology response may be expected to cost more to manufacture. To fill this potential gap in the analysis, CAEP investigated methodologies for quantifying these additional manufacturing costs. One methodology, based on price after technology response (PATR) computations, estimates these costs as the increase in aircraft price resulting from the application of TRs. There were divergent views within CAEP on the use of PATR, and therefore it was agreed that PATR would only be incorporated as a sensitivity analysis into the CO₂ma for TR-related costs.

6. TECHNOLOGY ASSUMPTIONS FOR THE COST EFFECTIVENESS ANALYSIS

6.1 The technology-related assumptions developed to be used in the CO₂ma dealt with issues of technical feasibility, CO₂ Technology Responses, costs, interdependencies with noise and engine emissions, and other aeroplane technology related issues such as transition pairs and the technology applied across aeroplane families.

6.2 Technical Feasibility

6.2.1 Building on past NO_x and noise definitions of technical feasibility and in the context of technology for improved emissions environmental performance to be used as part of the basis for the ICAO CO₂ certification Standard setting, technical feasibility refers to any technology expected to be demonstrated to be safe and airworthy proven to Technology Readiness Level 8 (TRL) 8 by 2016 or shortly thereafter²⁸, and expected to be available for application in the short term²⁹ over a sufficient range of newly certificated aircraft.

6.3 CO₂ Technology Responses

6.3.1 A CO₂ technology response refers to the manufacturer's action when an InP aeroplane does not meet the level of a SO. Manufacturers have provided technology response information, which was supplemented with additional technology response input from within CAEP. These were in the form of percentage metric value improvements, are only for CO₂ cost effectiveness modelling purposes, and do not imply a commitment for actual individual products. As part of this input, some aeroplane families included in-production configurations which were considered to be transition pairs and due to be gradually replaced with similar in-development project aeroplane types. There were also configurations in the same family which were not considered part of a transition pair, and which were allocated a "no technology response" due to market considerations that were based on historical business decisions (e.g. A318-122, A319CJ, B737-600, B737-700IGW).

6.3.2 A key assumption is that aeroplane technology will be assumed to remain at its current state, that is, current aeroplane types will have the same CO₂ metric values in 2040 as they do today unless they are changed to meet an SO. As a result, costs and benefits values aim to reflect the effects of the CO₂ SOs alone. Aeroplane types with technology responses will be certified on the date of applicability (e.g. 1-1-2020 and 1-1-2023) and will then be available in the CO₂ma. The proposed technology responses to the CO₂ SOs were compiled within a Stringency Options database (SOdb), which was used to create the necessary data and information needed for CAEP to conduct the CO₂ma.

6.3.3 As part of wider discussions on technology responses, input on improvements made after Entry into Service (EIS) was considered for some project aeroplanes equipped with Pratt Whitney Geared Turbofan (GTF) engines. It was recognised that the MVs for the GTF-powered A320-family types delivered in/after 2019 are expected to be better than for initial deliveries. However, because the SO Pass/Fail status will not change, and the CO₂ma is a comparative analysis, any effect on the overall results would be small. Consequently no change was made to the CO₂ Metric Values (MV) or MTOM for GTF-powered aircraft types.

²⁸ Per CAEP member guidance; approximately 2017

²⁹ Approximately 2020

6.4 Non-recurring costs and recurring production costs

6.4.1 A methodology has been developed to estimate non-recurring costs, based on a Continuous Modification Status (CMS) approach. Given inputs on the aeroplane MTOM, and required CO₂ metric value improvement, the CMS methodology yields non-recurring costs associated with the technology response as well as noise and NO_x trade-offs. All technology responses will start from the zero position in terms of metric value improvement and NRC. Due to the difficulties in obtaining proprietary cost data, the validation of the methodology relied on expert engineering judgment and publicly available aeroplane development cost information with restricted insight into what costs were incorporated within these data, and the starting TRL. Because of the use of publicly available aeroplane development cost information, in many cases multiple enhancements were inextricably linked (e.g. in-flight entertainment, noise and fuel efficiency from high bypass ratio engines), making the incremental cost of CO₂ technology difficult to directly assess. In addition to publicly available information, data was used to estimate the cost for small CO₂ Metric Value improvements from the incorporation of single technology CO₂ responses. As such, the accuracy of the costs generated by the NRC methodology is categorised as only representative but considered fit for purpose.

6.4.2 The NRC method was based on the functional form of the NRC surface as shown in Equation 1, where NRC is measured in billions of US Dollars with a 2010 reference year. The development of the method was based on data from stakeholders within CAEP. This NRC method results in a surface that represents low and high ΔMVs. This is of particular importance in the low ΔMV portion of the NRC surface, where validation points were lacking. The cost-surface has been calibrated to yield NRC estimates across a wide range of aeroplane sizes and metric value improvements. The method consists of a single cost surface that is a function of metric value improvement and aircraft MTOW.

$$NRC (10^9 \$) = \left(\underbrace{(A \cdot e^{(B \cdot x)} + C)}_{\text{Reference Airframe NRC}} + \underbrace{(A \cdot e^{(B \cdot 0.9)} + C) \cdot f(\Delta MV)}_{\text{Reference Engine NRC}} \cdot \frac{2}{\# \text{Engines}} \right) \cdot \underbrace{\left(\frac{MTOW}{MTOW_{ref}} \right)^D}_{\text{Aircraft Size Scaling}}$$

Equation 1: Function to describe the NRC cost surface

Where coefficients and functions; A, B, C, D and f(ΔMV) are defined as follows:

NRC Surface Coefficients

A	B	C
0.188902	3.247077	-0.142274

6.4.3 All coefficients are regressed based on MV improvement data, except for D, which along with f(ΔMV), is represented as a sigmoid function, as illustrated in Figure 6. Due to the boundaries of metric value improvements varying with MTOW, the cost surface is driven by a normalized metric value improvement. The normalized metric value improvement is given by:

$$\text{Normalized MV Improvement} = x = \frac{(\text{Abs.MV Impr.} - \text{MV Impr. Lower Bound})}{(\text{MV Impr. Upper Bound} - \text{MV Impr. Lower Bound})}$$

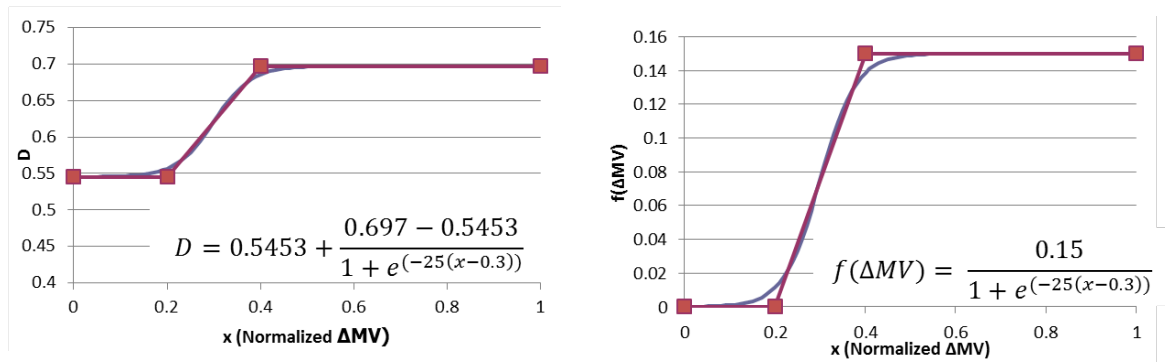

Figure 6: Coefficient D (left) and $f(\Delta MV)$ (right) Formulation

6.4.4 Information on changes to production costs after a technology response (i.e. recurring production costs) was not available to CAEP.

6.5 Recurring Direct Operation Cost Modelling

6.5.1 The recurring direct operating costs (DOC) include: (a) capital costs (including finance and depreciation), (b) other-DOC (including crew, maintenance landing and route costs) and (c) fuel costs. The primary model used for modelling other-DOC and capital costs was APMT-E; and, fuel costs were derived from AEDT fuel burn data. The FCM was used to confirm the results using both AAT and APMT-E fleet evolution data along with AEDT fuel burn data. The following is a full list of FCM inputs.

- Operations: The number of departures by scenario (for the baseline and each stringency option) by competition bin and analysis year. Operations are used in the estimation of crew and maintenance costs and airport charges;
- Flight kilometres: Distance flown in kilometres by scenario, competition bin and analysis year. This variable is used, in conjunction with the average cruise speed, in the estimation of flight hours;
- Fuel burn: Fuel in mega-tonnes by scenario, competition bin and analysis year. This variable is used in the estimation of fuel costs and CO₂ emissions;
- Average taxi time: 26 minutes;
- Fuel price: The assumed fuel price for the analysis is \$3.00 per US gallon (2010 US Dollars);
- Depreciation rate: The depreciation rate for this analysis is 6.53%;
- Financing rate: The financing rate for this analysis is 5%;
- Block hours: are used in the estimation of crew and maintenance costs and airport charges;
- Average unit crew cost and unit maintenance cost: computed per block hour by competition bin;
- Average unit route charge: computed per kilometre flow by competition bin; and
- Average unit airport charge: computed per operation by competition bin.

6.6 The FCM aggregates projected annual costs over the forecast period at the global level, combining non-recurring and recurring costs. It computes the present value of the discounted cash flows for each stringency option compared against the no stringency base case using a range of discount rates. Specifically, costs were estimated for the baseline and each stringency option as follows:

- Crew costs: Block hours x average unit crew cost (by competition bin).
- Maintenance costs: Block hours x average unit maintenance cost (by competition bin)
- Route charges: Distance flown x average unit route charge

- Airport charges: Operations x average unit airport charge
- Fuel costs: Fuel burn (mega-tonnes) x fuel price (\$/gallon) x conversion factor (gallon/mega-tonne)
- Depreciation cost: For the first year, depreciation cost = investment (in that year) x depreciation rate. For subsequent years, depreciation cost = [cumulative investment – cumulative depreciation] x depreciation rate.
- Financing costs: For the first year, financing cost = investment (in that year) x financing rate. For subsequent years, financing cost = [cumulative investment – cumulative depreciation] x financing rate.

6.7 Project aeroplane types

6.7.1 Since Project aeroplanes types are still in development, final performance is not specifically known. To accommodate this, data on project aeroplanes was provided with the PAMVdb as a range of CO₂ metric values and MTOM to represent the uncertainty associated with the final certified values. Table 6 below lists the Project Aeroplane types that were included in the analysis.

A350-800	A350-900	A350-1000
A319NEO	A320NEO	A321NEO
Boeing 737-7	Boeing 737-8	Boeing 737-9
Bombardier CS-100	Bombardier CS-300	
Cessna Model 680		
Cessna Model 750		
Irkut MS-21-300	Irkut MS-21-200	
Mitsubishi MRJ70	Mitsubishi MRJ90	
Illushyn IL-114-300		
Embraer E175-E2	Embraer E190-E2	Embraer E195-E2
Boeing 787-10		
Boeing 777-9X		
Comac C919ER		
A330-800NEO	A330-900NEO	

Table 6: Project Aeroplane Types

6.7.2 Since data was provided as a range of MTOM and metric value, this created a rectangular space defining a potential range of performance of each project aeroplane. The most conservative “upper left corner” point (highest metric value and lowest MTOM) was used as a simplification of this uncertainty. A similar conservative approach was taken for having no technology responses to CO₂ SOs due to the uncertainty in the project aeroplane performance.

6.7.3 A number of project aeroplanes were not included within the CO₂ma and these are shown in Table 7.

Manufacturer	Aeroplane Type	Est.Type Certification Date	Notes	Rationale
Airbus	A330 Regional	2015	Reduced A330 MTOM variant optimised for shorter haul missions with high seat count and new de-rated version of Trent 700 engine with latest performance upgrades.	Covered by existing A330-200 and -300 configurations.
Boeing	B777-8X	2023	Derivative version of the B777 twin-aisle airplanes.	Outside the scope of technical feasibility as per CAEP Members guidance.
Bombardier	350	2014	Derivative version of the existing Bombardier 300 with 4.5% higher MTOM, upgraded engine and revised winglet design.	Covered by existing Bombardier 300 configuration.
	7000/8000	2016/2017	Ultra long-range corporate jet aircraft	No data provided due to commercial sensitivity.
COMAC	ARJ21	2014	New single aisle, short-range twin engine turbojet aircraft.	No data provided as in a critical phase of certification.
Dassault	5X	2017	New twin engine business jet.	No data provided due to commercial sensitivity.
Embraer	Embraer L1000E	2014	Ultra long range business jet based on Embraer E190 with enhanced range capability.	Covered by existing Embraer L1000 configuration.
	Legacy 450/500	2014	New small and mid size business jets.	No data provided due to commercial sensitivity.
Pilatus	PC-24	2017	New twin engine business jet.	No data provided.

Table 7: In-development (project) aeroplane types not included in the CO₂ Standard-setting process

6.8 Aeroplane transition pairs

6.8.1 Considering the definition of technical feasibility, the transition between in-production and project aeroplane pairs occurs over a six-year span beginning with the year the project (transitioning in) aeroplane is listed as entering into service (e.g. A320neo replaced A320ceo, B737MAX replaced B737NG). The process is implemented in a step manner where the project aircraft is limited to 15% of the combined demand for the transition pair in the first year. By the sixth year of the transition the project aircraft will take 90% of the purchase share, relative to its in-production transitioning out partner, and it will gain 100% of the share in the seventh year. Details on the aeroplane transition pairs are provided in Table 8.

Transition Pair
Project E175-E2 replaced E175
Project E190-E2 replaced E190
Project E195-E2 replaced E195
Project A319-NEO replaced A319-1
Project B737-7MAX replaced B737-7 and -7W
Project A320-NEO PW replaced A320-2
Project A320-NEO CFM replaced A320-2
Project B737-8MAX replaced B737-8 and -8W
Project A321-NEO PW replaced A321-2
Project A321-NEO CFM replaced A321-2
Project B737-9MAX replaced B737-9ER and -9ERW
Project B777-9X replaced B777-300ER
Project C680 post SN500 replaced C680
Project C750 post SN500 replaced C750
Project Learjet 70 post SN133 replaced Learjet 40
Project Learjet 75 post SN455 replaced Learjet 45
Project B737-8MAX BJ replaced B737-7 IGW BJ
Project A330-800neo replaced A330-200
Project A330-900neo replaced A330-300

Table 8: Transition pairings between in-production and project aeroplane.

6.9 Technology changes applied across aeroplane family

6.9.1 In-Production and in-development (project) aeroplane models, having a common build standard (i.e. certified on the same Type Certificate (TC)), are grouped into aeroplane families. If any model within a given aeroplane family fails a given stringency option and responds via technology insertion, then all the aeroplane models within the family will receive the same level of technology insertion. Family members that pass a stringency line are assumed to receive this family technology response by default. NRC will be based on the MTOM of the heaviest member of the family receiving a technology response, even if the heaviest member of the family is not the one that triggered the response for the family. The NRC is attributed to the whole family and not split over individual family members. This assumption is based on the need for fleet commonality amongst aeroplane design in order to minimize manufacturer and operator costs, and has been demonstrated in practice. For reference, the aeroplane families used in the CO2ma are shown in Table 9.

Aircraft Family	Aircraft Types	Aircraft Family	Aircraft Types
A320ceo	A318-100, A319-100, A320-200, A321-200	Lear 60	Learjet 60XR
A320neo	A319neo, A320neo, A321neo	Lear 75	Learjet 70, Learjet 75
A330	A330-200, -300, -200F	Q400	Q400
A330neo	A330-800neo, A330-900neo	CNA525B	CJ3 Model 525B CitationJet
A350 XWB	A350-800, -900, -1000	CNA525C	CJ4 Model 525C Citation
A380	A380-800	CNA560-XLS	XLS+ Model 560XL Citation
AN140	AN-140-100	CNA680	Sovereign CNA680, CNA680-S
AN148/158	AN-148-100E, AN-158	CNA750	CX Model 750 Citation, CNA750-X
AN32	AN32P	F2000	F2000 LX
AN72	AN74TK-300D	F7X	F7X
ATR42/72	ATR42-500, ATR72-212A	F900	F900 LX
B737MAX	B737-7, -8, -8 (BBJ), -9	E-Jets 2	E175-E2, E190-E2, E195-E2
B737NG	B737-700, -800, -900ER	ERJ170/175	ERJ175
B737NG (Winglet)	B737-700W, -700IGW(BBJ), -800W, -900ERW	ERJ190/195	ERJ190, ERJ195
B747	B747-8i; B747-8F	ERJ135/145	ERJ135-LR, ERJ145
B767	B767, -300ER, -300F	L650	L650
B777	B777-200, -200ER	Phenom	P300
B777LR	B777-200LR, -300ER; B777-2LRF	G280	G280
B777X	B777-9X	GULF150	GULF150
B787	B787-8, -9, -10	GULF4	GULF450
Challenger 300	Challenger 300	GULF5	GULF550
Challenger 600	Challenger 605	GVI	GVI
Challenger 850	Challenger 850	IL114	IL114-100
C919ER	C919ER	MS-21	MS-21-200, -300
CRJ	CRJ-700, -900, -1000	MRJ	MRJ-70, -90
CSeries	CS100, CS300	RRJ	RRJ-95, -95LR
Global	G5000, G6000	TU-204	TU-214, TU-204-300, TU-204SM
Lear 45	Learjet 40XR, Learjet 45XR	TU-334	TU-334

Table 9: Aeroplane families used in the CO2ma

6.9.2 Any aeroplane which fails an SO, and is explicitly identified as not receiving a technology response, is not included in the family response for that stringency option. No aeroplane in that situation will be used as the basis of calculating MV impact or NRC.

6.10 Margin to Stringency Option

6.11 Technology responses are required to meet an SO by an additional one percent margin to the SO in order to take into account manufacturer and policymaking risks, and facilitate subsequent modelling efforts in performing the CO2ma. This simplified margin assumption was not used to judge whether an aircraft passes or fails a given SO, in other words, it is not used to define the “yes/no” technology response input. The margin was used to establish what the metric value impact will be to achieve the SO level. This was then used to establish the NRC data and the fuel burn changes.

6.12 CO₂ scaling methodology

6.12.1 A 1:1 ratio was used between delta CO₂ metric value and mission fuel burn for Technology Response because it is expected that, on the whole for a comparative analysis, the net change in fleet fuel burn between SOs should be reasonable. It is recognized that this is not a correct assumption at the aircraft level and should be looked at again for future stringencies.

6.13 **NOx trade-offs**

6.13.1 Considering the definition of technical feasibility, it is assumed to be a 1:1 ratio where a 1% improvement in aeroplane fuel burn would thus result in a 1% improvement in LTO and cruise NOx emissions. This is on the basis that engine changes are neutral between temperature increases and improved combustion technology and that the same per cent improvement in engine NOx performance at all the four emissions certification thrust settings of 100, 85, 30 and 7%.

6.14 **Annex 16, Volume I, Chapter 14 noise production assumptions**

6.14.1 The baseline fleet evolution allows Annex 16, Vol. I, Chapter 14 noise technology responses for all modelled aeroplane types at the CO₂ applicability dates for new types. This does not mean that all aeroplanes which are non-Chapter 14 compliant will respond, but that they may respond based on the technical discussions within CAEP. Aeroplane types which would not respond to Chapter 14 will not be available for the CO₂ma, except for those which are part of “transition pairs” with separately agreed timescales. No costs or benefits from the baseline fleet evolution Chapter 14 responses will be attributed to the CO₂ Standard-setting process. This includes fuel burn trade-offs which was recognised as a conservative approach for some proposed Chapter 14 responses (e.g. re-engining) which would be expected to lead to significant fuel burn improvements.

6.15 **Noise trade-offs**

6.15.1 Detailed information on specific CO₂ technology responses could not be provided given their proprietary nature. Consequently it was concluded that it was not feasible to devise a generic noise-CO₂ interdependency function which is generally applicable to all aircraft in all scenarios. Instead some general high level input was provided by CAEP experts on noise and fuel burn trade-offs.

6.15.2 As the validation points in the NRC methodology included noise improvement costs which could be considered to mitigate any adverse noise trade-offs, it was considered reasonable to assume that the noise performance following a CO₂ technology response would remain neutral. However, it was noted that CO₂ technology responses may have beneficial noise trade-offs, which would not be captured.

6.15.3 Given the schedule for the CAEP/10 CO₂ stringency cost-effectiveness analyses, a simplified assumption compatible with other modelling assumptions would be appropriate. Therefore, noise trade-offs have not formed part of the CAEP/10 CO₂ Standard-setting process for CO₂ technology responses.

6.16 **Particulate Matter trade-offs**

6.16.1 Particulate matter (PM) emissions from aircraft engines are not regulated nor measured in a consistent manner. As a result, CAEP did not have sufficient confidence to assess the trade-offs on aeroplane engine PM emissions and, as such, it has not formed part of the CAEP/10 CO₂ Standard-setting process.

6.17 **Aeroplanes Impacted by the Combined Assumptions**

6.18 When combined together in the CO₂ma, the technology related assumptions allow for modelling of how the global fleet of aeroplanes responds to the ten SOs. To illustrate this, Figure 7 shows the percentage of impacted aeroplanes which (1) are “transition pairs”, (2) meet the SOs, (3) are fixed due to a technology response, and (4) do not meet the SOs.

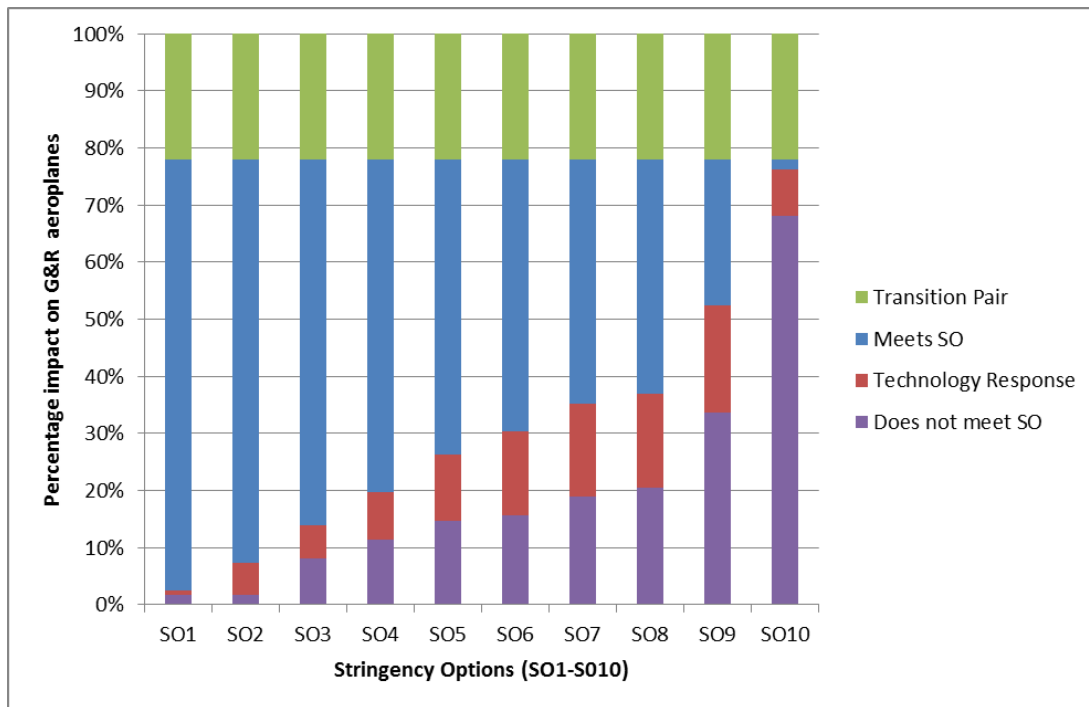

Figure 7: Illustrates the percentage of impacted aeroplane types due to the ten SOs.

7. APPLICABILITY OPTIONS - SCOPE/TRIGGER/DATE

7.1 The scope of applicability for the CO₂ Standard work shall include new aeroplane types in the form of subsonic jets with Maximum Take-Off Mass (MTOM)>5700kg (12566lb) and propeller driven multi-engine aeroplanes (turboprops) with MTOM>8618kg (19000lb). These mass categories correspond to those used in Annex 16 Volume I for the certification of aircraft noise and the Annex 8 large aeroplane airworthiness requirements, and thereby capture aeroplane types which represent >99% global fuel burn, flight distance and operations. For the NT standard the CO₂ Standard applicability dates which were considered included 1 January 2020 or 1 January 2023. Proposals have also been developed for InP aeroplane type applicability requirements and dates proposed for evaluation within the CO2ma.

7.2 In-production applicability options development

7.2.1 A set of broad options were defined to implement applicability requirements for InP aeroplane types. It was recognised that the elements of an applicability option (e.g. applicability date, process, InP/NT regulatory level, trigger) could be used to identify an appropriate balance between the costs and administrative burden with the utility and data robustness, thereby taking into account the specific concerns expressed by stakeholders (e.g. manufacturers and regulatory authorities). A full range of options were considered, as described in Figure 8.

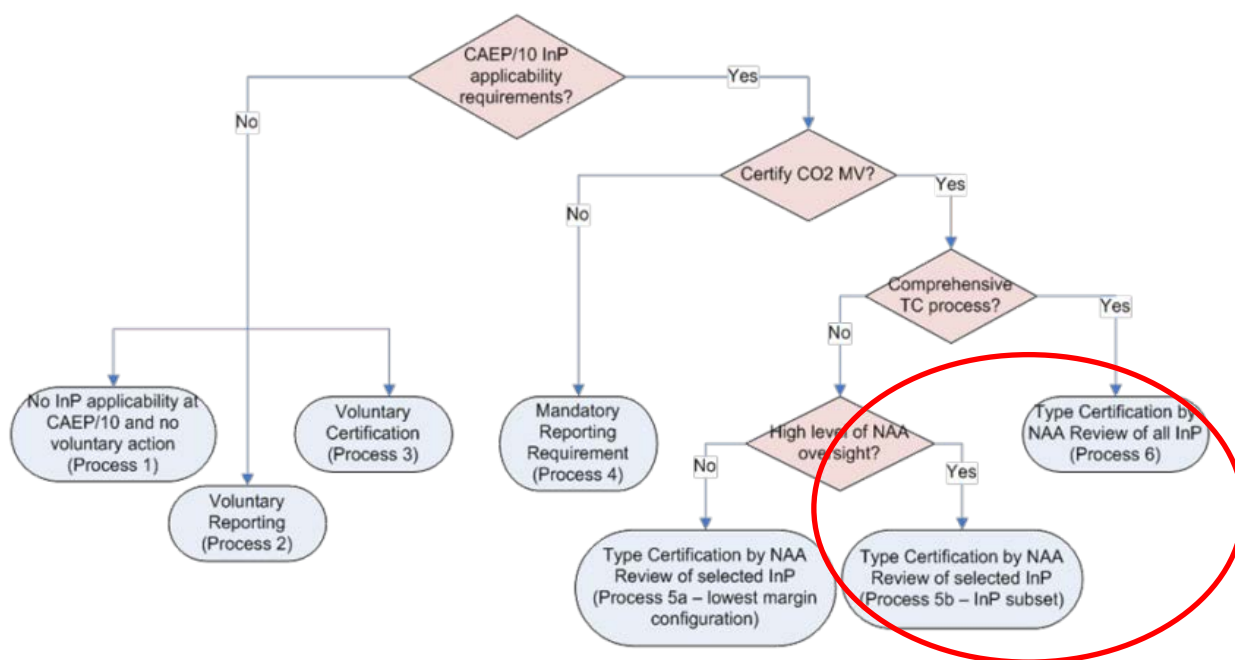

Figure 8: Potential mandatory processes which were investigated as possible InP applicability options

7.2.2 With reference to Figure 8, the details behind the options for potential processes, hybrid approaches and triggers for an InP CO₂ Standard are as follows:

POTENTIAL IMPLEMENTATION PROCESSES³⁰

1. **No InP applicability and no voluntary action** – There will be no InP requirements, and focus will be on applicability requirements for new aeroplane types only. (Process 1)
2. **Voluntary Reporting** - Aeroplane CO₂ MVs would be voluntarily provided by manufacturers directly to CAEP for inclusion in the ICAO CO₂DB. There would be no NAA review of the data, no regulatory level, and all data would be marked as “uncertified”. (Process 2)
3. **Voluntary Certification** – Would be the same as Voluntary Reporting, but would be reviewed by an NAA according to ICAO Annex 16 Volume III and marked as “certified”. (Process 3)
4. **Mandatory Reporting** - Aeroplane CO₂ MVs would be provided by manufacturers to NAAs for provision to CAEP and inclusion in the ICAO CO₂DB. There would be no NAA review of the data, no regulatory level, and all data would be marked as “uncertified”. (Process 4)
5. **Type Certification by NAA Review of selected InP** - The NAA would review some, but potentially not all, of the aeroplane type configurations according to ICAO Annex 16 Volume III and on that basis develop certified CO₂ MVs to all configurations. (Process 5a & 5b)

³⁰ Processes 2 and 4 are purely Reporting Requirements with uncertified CO₂ MV data, and are therefore considered unsuitable for applying a regulatory level. Processes 3, 5, and 6 include Type Certification elements which result in the determination of certified CO₂ MV data, and could thus be considered with or without a regulatory level.

- 6. Type Certification by NAA Review of all InP** - The CO₂ MVs for all InP aeroplane type configurations would be certified by an NAA according to ICAO Annex 16 Volume III. (Process 6)

POTENTIAL HYBRID APPROACHES

Hybrid approaches aim to balance the data credibility and resource concerns highlighted with pure Reporting or TC processes, while not undermining the original objective of Annex 16 Volume III, which is to act as a robust standard that provides a fair and comparative measure of fuel efficiency technology integrated into a range of aeroplane type design.

- 1. Type Certification by NAA Review of selected InP aeroplanes (Process 5)** - The NAA would review some, but potentially not all, of the configurations according to ICAO Annex 16 Volume III and on that basis allocate certified CO₂ MVs to all configurations. This has two sub-processes:

- a) Process 5a (lowest margin) - The NAA would review in detail and certify the configuration in each family with the lowest margin to the regulatory level, and the same margin would be used to develop initial conservative CO₂ MVs for all configurations in that family. All aircraft would be marked as “certified” within the CO₂DB. Once all InP aeroplane types have an initial certified CO₂ MV, then each InP type would be subsequently treated individually within the TC process and not as a family.
- b) Process 5b (InP subset) - The NAA would certify some, but potentially not all, of the configurations in a type certification application to provide sufficient confidence that all configurations could be classified as “certified”. The number of configurations to be certified, and the appropriate selection criteria, would need to be defined.

- 2. Mid gross mass SAR certification test point only (Processes 2 to 6)** - This would require a manufacturer to only perform flight tests to measure one certification test point (the mid gross mass SAR value) where existing flight test data is insufficient to meet Annex 16 Vol. III, Chapter 2 requirements of three certification test points (low, mid and high gross mass SAR values).

POTENTIAL TRIGGERS FOR IN-PRODUCTION CERTIFICATION³¹

It was recognized that there could be a range of options that could be used to trigger an InP certification.

- 1. Voluntary (Applicable to processes 2 and 3)** - Manufacturers would initiate the process to provide CO₂ MV data on their InP aeroplane types at a time of their choosing.
- 2. Certificate of airworthiness for the individual aeroplane first issued on or after a future date (Applicable to processes 4 to 6)** - As per other existing Annex 16 requirements³², the CO₂ applicability process would be initiated for InP aeroplane types based on the date of issuance

³¹ The use of additional criteria in the applicability trigger, such as an MTOM threshold or type certification date, have been identified to potentially further refine the applicability scope of Annex 16 Vol. III to a selected subset of InP aeroplane types.

³² Annex 16, Volume I, Chapter 2 (Subsonic jet aeroplanes — Application for Type Certificate submitted before 6 October 1977), Chapter 5 (Propeller-driven aeroplanes over 8 618 kg — Application for Type Certificate submitted before 1 January 1985), Chapter 6 (Propeller-driven aeroplanes not exceeding 8 618 kg — Application for Type Certificate submitted before 17 November 1988) and Chapter 12 (Supersonic aeroplanes).

of a Certificate of Airworthiness for a new InP aeroplane³³. The associated text, similar to that used in Volume I, could take the form of "...for which the application for a Type Certificate was submitted before XX-XX-20XX and a certificate of airworthiness for the individual aeroplane was first issued on or after XX-XX-20XX".

3. Change criteria (Applicable to processes 4 to 6) - The CO₂ applicability process would be initiated when an application is submitted to the NAA by a manufacturer to modify an InP aeroplane type design, and that modification meets an specific change criteria.

7.3 Proposed InP options to CAEP

7.3.1 Overall, while all of the processes shown are possible options for a CAEP/10 decision, including no InP applicability, it was agreed to build on mandatory processes 5b and 6 which included type certification elements that accurately derived the CO₂ metric value performance of aeroplane type configurations (see red circle in Figure 8).

7.3.2 Regarding the possible InP applicability dates, a sensitivity analysis was performed using the dates of 1 January 2025 and 1 January 2028. However, 1 January 2028 was considered an upper boundary condition in terms of InP applicability dates, as anything beyond that date is too far-reaching for a decision at the CAEP/10 meeting 2016. It was also agreed that an InP applicability date of 1-1-2020 could be considered if the trigger was based on a criteria that would only be triggered by a technical change to an existing aeroplane type design. This is referred to as a CO₂ change criteria and more information can be found in the draft First Edition of Annex 16, Volume III.

7.3.3 It was recognised that implementation of a mandatory InP applicability option would probably involve a combination of both Process 5b and 6 (Figure 8 refers). A certifying authority will discuss an appropriate level of involvement with the applicant during each TC process. This is likely to include a more detailed review during an initial TC programme, while subsequent applications from the same applicant would require less involvement as the certifying authority gains confidence in the applicant's processes and capabilities.

7.3.4 Taking into account all of the above, three potential mandatory, type certification based options were subsequently developed and are summarised in Table 10. They are presented as a framework which aims to inform the decision on certain details (e.g. choice of date, regulatory level).

³³ New in-production aeroplane: An individual aeroplane that receives a certificate of airworthiness first issued after the date when the in-production standard becomes applicable, and which is not certified against the new type standard.

	Option 1	Option 2	Option 3
Scope	As per New Types		
Date (change criteria)		1-1-2020 <u>or</u> 1-1-2023 <u>or</u> 1-1-2025	1-1-2020 <u>or</u> 1-1-2023 <u>or</u> 1-1-2025
Date (production cut-off)	1-1-2023 <u>or</u> 1-1-2025 <u>or</u> 1-1-2028		1-1-2023 <u>or</u> 1-1-2025 <u>or</u> 1-1-2028
Trigger	Applicability date based on initial certificate of airworthiness for the individual aeroplane.	Application for a design change that meets a specific change criteria.	Application for a design change that meets a specific criteria. If not triggered by a change, then will be default triggered by an applicability date based on the initial CofA for an individual aeroplane on or after a date ³⁴ later than the change criteria applicability date.
Regulatory Level	Separate InP and NT regulatory levels <u>or</u> a single InP/NT regulatory level		
Process	Full type certification as per Annex 16 Vol. III Chapter 2, allowing for equivalent procedures ³⁵ and discussions between the certifying authority and the applicant on an appropriate level of involvement in a particular type certification programme		

Table 10: Potential mandatory, type certification based InP applicability options

- Option 1 represents a requirement for all aeroplanes to certify to the standard by the date. A production cut-off for all InP aeroplane types if they have not been certified to the CO₂ Standard by this date.
- Option 2 represents applicability being triggered only if an application for a design change for new in-production aeroplanes exceeds a specific CO₂ change criteria. This change criteria was defined as an increase in CO₂ emissions MV of greater than 1.5% or a significant CO₂ change (e.g. new wing or engine option). There would be no production cut-off that would require aeroplanes to certify by the dates above.
- Option 3 represents a hybrid approach, where Option 2 is active for a period of time and is subsequently followed by Option 1.

7.3.5 Options 1 and 3 have triggers with an applicability date based on the issuance of the initial certificate of airworthiness for an individual aeroplane. It is recognised that aeroplanes released into service before a type configuration is certified to meet the InP requirement, may have the same type

³⁴ In terms of Option 3, it is noted that the applicability of a production cut-off could reasonably lie in the range of 3 to 5 years after the applicability of a change criteria.

³⁵ ETM Vol. III guidance should be developed over time to identify equivalent procedures that are a more cost-effective means of compliance compared to the requirements in Annex 16 Vol. III.

configuration as those entering service after the type configuration was certified. In this situation, those aeroplanes that entered in to service before the identical configuration was certified, could volunteer to be CO₂ certified as well. Once CO₂ certified, these aeroplanes would be required to continue to demonstrate compliance with the Annex 16 Vol. III Standard via the CO₂ certification change process.

7.3.6 In considering the potential future effect of the proposed three options, it was recognised that these could potentially vary significantly. Options 1 and 3 end in a production cut-off date by which all InP aeroplane types are expected to be CO₂ certified.

7.3.7 Options 2 and 3 include specific change criteria which would trigger the applicability of the CO₂ standard. The proposed criteria are an adverse 1.5% change in the CO₂ metric value of the aeroplane type configuration or a significant change (e.g. new wing or engine option³⁶). It is difficult to predict what, and when, future changes will be demanded by the market, and whether they would trigger these applicability criteria. However, historical data suggests that the adverse 1.5% change criterion would be primarily triggered by increases in the highest MTOM mass for the specific aeroplane type configuration. It should also be highlighted that applicants historically have voluntarily sought certification of significantly beneficial changes to the latest environmental standards. Finally, it is noted that this trigger would result in the post-change derived InP type configuration being certified, but no mandatory certification requirement would apply to the pre-change InP type configuration.

7.4 **The possible timeline for mandatory NT and InP type applicability options**

7.4.1 To understand further the implementation of the mandatory NT and InP type applicability options detailed in Table 7 there were several issues to comprehend regarding the timeline.

7.4.2 An applicability date should take into account that integrating the CAEP/10 agreement into Member State legislative frameworks will take approximately three years (e.g. end of 2018). Schedule risks have been identified, for example if Member States do not integrate Annex 16 Vol. III into their legislative frameworks in a timely manner such that industry can meet its mandatory obligations (e.g. tech response and certification).

7.4.3 The certification basis for New Types is valid for five years from the date of application for type certification. If the TC process goes beyond five years, then the certification basis is reviewed and, if necessary, updated.

7.4.4 For the InP applicability trigger, an applicability date based on an aeroplane's initial certificate of airworthiness represents a production cut-off requirement if the aeroplane type has not been certified before the applicability date. For example, a 2025 InP date would provide approximately six years for InP aeroplane types within the applicability scope to be made compliant. A CO₂ change criteria based trigger would require the approval of a design change application for an aeroplane type after the applicability date, when exceeding some agreed CO₂ change criteria. This would include the need to demonstrate compliance with the CO₂ Standard.

7.4.5 An applicability date will be influenced by what is considered pragmatic and implementable in terms of time needed for industry to respond to the final agreed CO₂ Standard (e.g. combination of a certification requirement and a regulatory level). A later applicability date may have been necessary for more stringent regulatory levels and vice versa.

³⁶ These criteria are intended to be triggered by generational changes made to in-production aeroplane types. Recently announced examples of generational changes which would have been triggered by these criteria if the application for type certification had been submitted after the CO₂ standard comes into effect include the E2 jets, 737MAX, A330NEO and B777X.

7.4.6 Annex 16, Volume I precedents have had an InP applicability date based on the initial certificate of airworthiness, and these InP applicability dates were typically four to five years after a NT applicability date.

8. RESULTS FROM THE COST EFFECTIVENESS ANALYSIS CO₂ MAIN ANALYSIS (CO₂MA)

8.1 The CO₂ma has been conducted in accordance with the framework described in Section 5.5 that considered CO₂ Standard application to both NT aeroplanes and new deliveries of InP aeroplane types. This section provides an overview of the important results from the CO₂ma.

8.1.1 Full flight performance-based CO₂ emissions results, presented in Figure 9, exhibit the expected trend of increasing benefits with increasing stringency. Noise results for areas and population counts within a 55dB Day-Night Average Sound Level (DNL) contour, as presented in Figure 10, show increasing benefit with the increasing SO modelled. NO_x emissions results, presented in Figure 11, are influenced by the relative NO_x performance of the aircraft available for growth and replacement (G&R) as they change with SO. Specifically, there is a greater NO_x benefit at SO5 when aircraft with relatively higher NO_x emissions drop out of the fleet mix. Conversely, SO6 aircraft with relatively lower NO_x emissions drop out of the fleet mix and are replaced by aircraft with relatively higher NO_x emissions, causing an overall increase in NO_x emissions.

8.2 Based on past CAEP practice, all of the Case 1 results represent a situation where a NT SO would be chosen and there would be no legal deadline to bring InP types to levels required under an NT-only standard. However, the CO₂ma assumptions are that aeroplanes not meeting a particular SO would be have a technology response informed by market considerations on the implementation dates for NT-only applicability, thus the modelled results represent a pseudo InP applicability. The results consistently reflect their relative time spans from the implementation year through 2040, including the change in costs results presented in Figures 12 through to 15. The CO₂ma Case 1 costs reported herein are influenced primarily by the reduction in fuel costs with increasing stringency, resulting in negative overall costs for all SOs. Thus, both the CO₂ma Case 1 costs and environmental benefits are driven by the same data (CO₂ saving/ fuel cost saving), leading to a flatter cost effectiveness profile than for previous environmental standard analyses.

8.3 The Case 4 results can be considered as a range of response scenarios from a voluntary response similar to Case 1 (section 8.2), down to an absence of any response by growth and replacement aeroplanes. The results were prepared for sub-case c, Section 5.5, which was the most limited in the range of voluntary NT-Only Applicability response scenarios considered. Because no types are required to go out of production under NT-only applicability, NO_x emissions only go down with increasing stringency levels; noise benefits are negligible; and, while CO₂ and cost savings increase progressively through SO10 without Price After Technology Response (PATR), and through SO9 with PATR, the amplitude of the savings is less than under NT and InP aeroplane Applicability case. These results are reflected in Figures 9 to 11 and Figures 16 through to 19.

8.4 Hybrid Applicability: It is recognized that there could be a range of possible combinations of standards adopted by CAEP. These responses would be influenced by both the NT-only SO level and the INP SO level since voluntary responses for INP types could occur both prior to the INP applicability date and/or beyond the INP SO level. As such, the assumptions from Case 1 and Case 4 were used to model a number of hybrid applicability scenarios where both NT and INP standards are adopted. These results are included in Figures 16 and 17, and provide an indication of potential responses but represent only part of a possible range of outcomes.

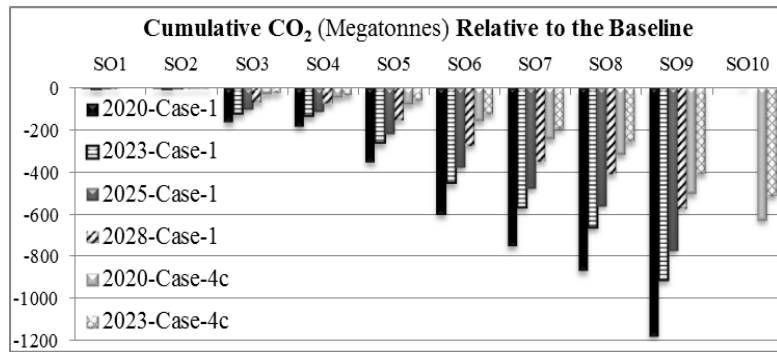

Figure 9: Cumulative CO₂ (Megatonnes)³⁷ Results³⁸ Relative to the No Stringency Baseline from the Implementation Year to 2040

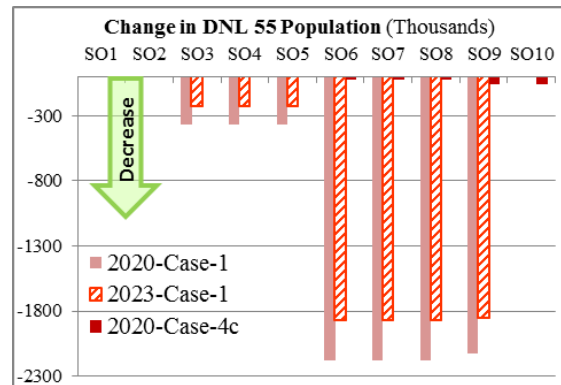
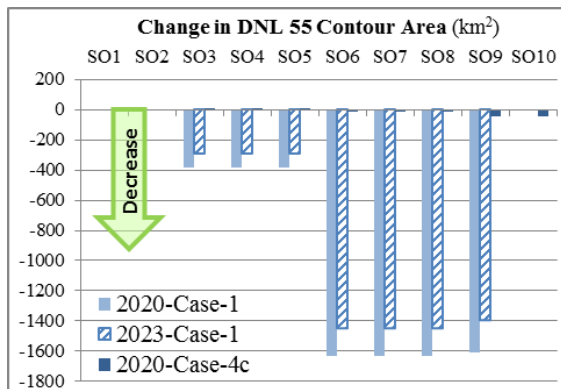

Figure 10: 2040 Noise Results Relative to the No Stringency Baseline at DNL 55dB

³⁷ Megatonne (Mt) a unit of mass equal to one million tonnes

³⁸ The results depicted were modelled by AEDT from APMT-E fleet evolution.

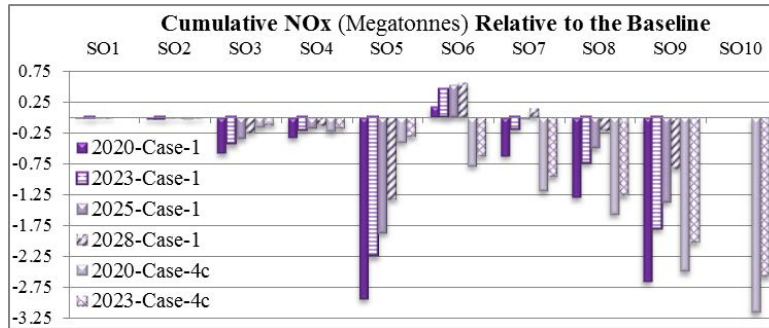

Figure 11: Cumulative NOx (Megatonnes) Results³⁹ Relative to the No Stringency Baseline from the Implementation Year to 2040

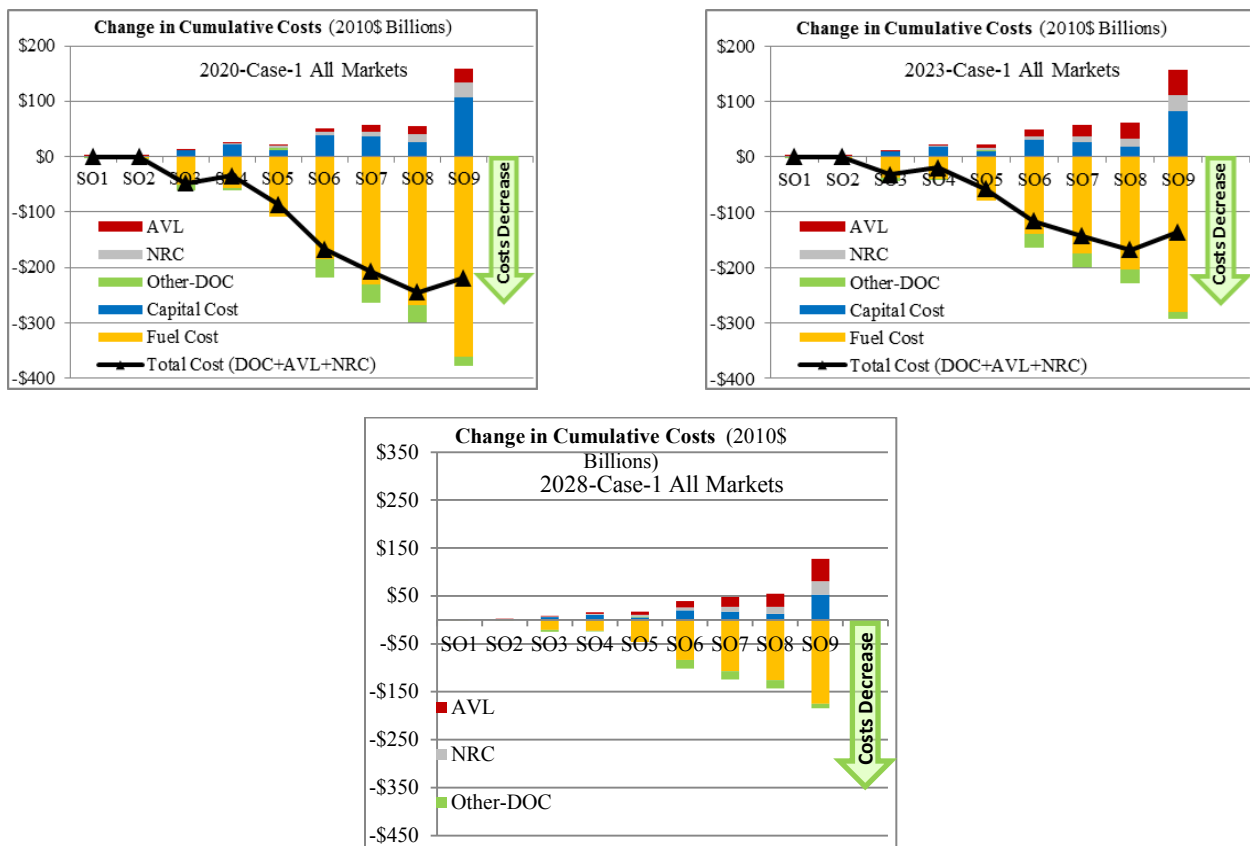

Figure 12: Change in Cumulative Costs for 2020, 2023 and 2028 Case-1 (US2010\$ Billions) Total Recurring Direct Operating Costs (DOC), Manufacturer Non-Recurring Costs (NRC) for Technology Response (TR) and Owner /Operator Asset Value Loss (AVL) from the Implementation Year to 2040

³⁹ The results depicted were modelled by AEDT from APMT-E fleet evolution.

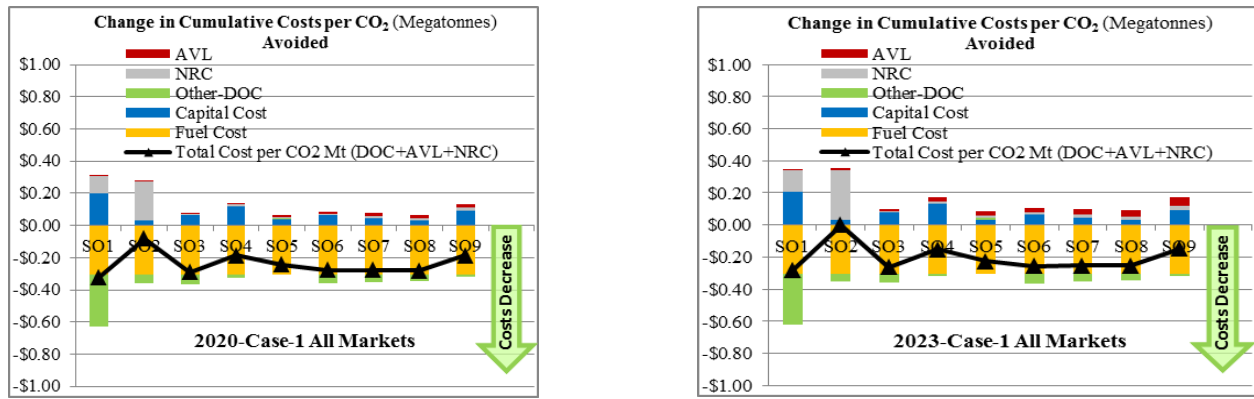

Figure 13: Change in Cumulative Costs per Megatonne CO₂ Avoided Total Recurring Direct Operating Costs (DOC), Manufacturer Non-Recurring Costs (NRC) for Technology Response (TR) and Owner /Operator Asset Value Loss (AVL) from the Implementation Year to 2040

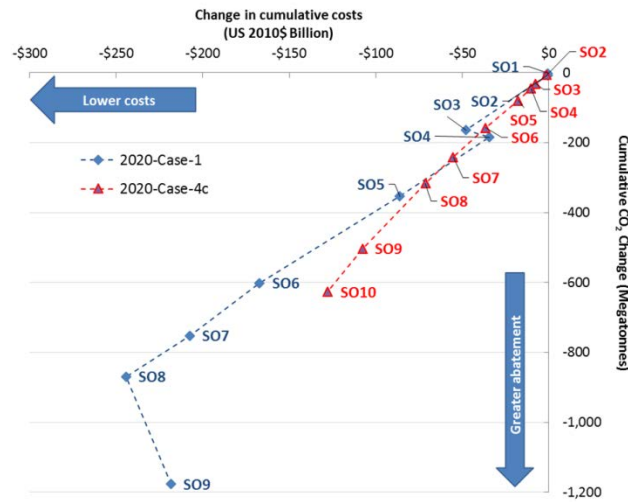

Figure 14 : 2020 Cases 1 and 4c Change in Cumulative Costs (DOC+AVL+NRC) versus Cumulative CO₂ Change from the Implementation Year to 2040

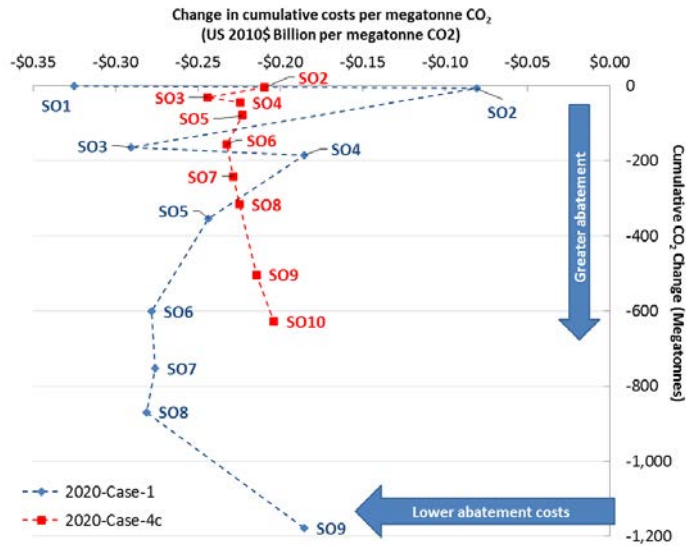

Figure 15: 2020 Cases 1 and 4c Change in Total Cumulative Costs (DOC+AVL+NRC) per Megatonne CO₂ (0% Discount Rate) against Cumulative CO₂ Change (Megatonne) from the Implementation Year to 2040

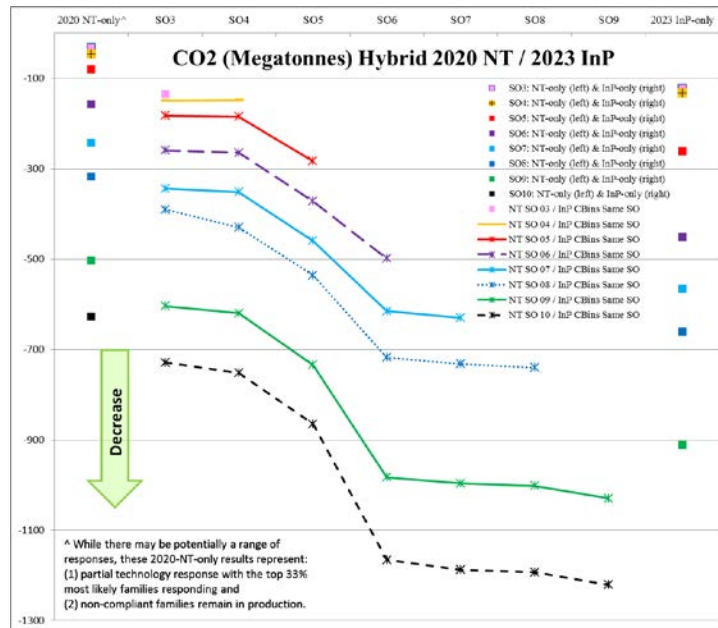

Figure 16: Modelled hybrid 2020-NT/2023-InP CO₂ results are shown in the middle, along with 2020-NT-only (Case-4c) results to the left and 2023-InP-only (Case-1) results to the right

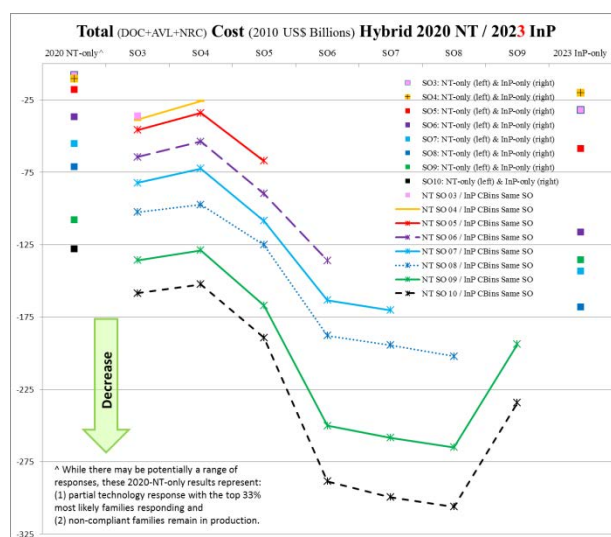

Figure 17: Modelled hybrid 2020-NT/2023-INP (DOC+AVL+NRC) Cost results are shown in the middle, with 2020-NT-only (Case-4c) results to the left and 2023-INP-only (Case-1) results to the right

8.5 The CO₂ma results discussed above assumed that the cost of manufacturing aircraft remains unchanged after they have been modified to meet an SO, whereas the additional technology contained in a technology response may be expected to cost more to manufacture (i.e., material, labour and other recurring costs). Results from a sensitivity analysis to capture the additional technology costs of responding aircraft, based on a proxy using a PATR methodology⁴⁰, are shown against other individual cost elements in Figure 14a and for different groupings of total costs in Figure 18b. These results show that even though magnitude varies when costs are combined in different ways, there is a consistent cost trend. When any combination of costs includes the change in cumulative fuel costs against the baseline, there is a savings; and, the savings increase from SO4 through SO8. For all “NT and INP” Applicability (Case 1) and hybrid results, both of which consider InP applicability, the combined cost savings at SO9 is consistently less than SO8. However, under the NT-only Applicability (Case 4) assumptions, when no INP types go out of production, the savings increase through SO10 without PATR or to SO9 when PATR is included. The InP applicability SO9 behaviour is due demand shifting to smaller aircraft that require more operations and aircraft to meet the demand, increasing capital and operating costs.

8.6 Within the CO₂ma, assumptions have been made regarding discount rates and fuel price. A sensitivity analysis on both of these aspects is shown in Figure 19 and Figure 20 respectively.

8.7 During the CO₂ Standard-setting process, much discussion was had over the contribution of aeroplanes above and below the 60t MTOM kink point. Figure 21 shows the CO₂ sensitivity results when above 60 tonne CBins are at SO5 through SO9 and combined with below 60t MTOM results at each SO. Much of this discussion was driven by unexpected results among business aeroplanes below 60t MTOM (CBins 1-3). These unexpected results were found to have been driven by initial assumptions that produced potentially unrealistic market behaviour that was not noticed until late in the analysis. This behaviour was qualitatively very different from that of the greater than 60t MTOM fleet, but due to the

⁴⁰ The PATR methodology represents the missing costs by the increase in aircraft price as a result of the technology response. The price increase is calculated based on a proportion of the projected fuel savings over the life of the aircraft. Since a product may in some cases sell for a significantly higher price than it actually costs to develop and produce, the use of PATR as a proxy for the total TR-related costs may overestimate the costs borne at system level

small CO₂ contribution of CBins 1-3, it is nearly undetectable within the larger fleet results, despite its significance for the impacted CBins.

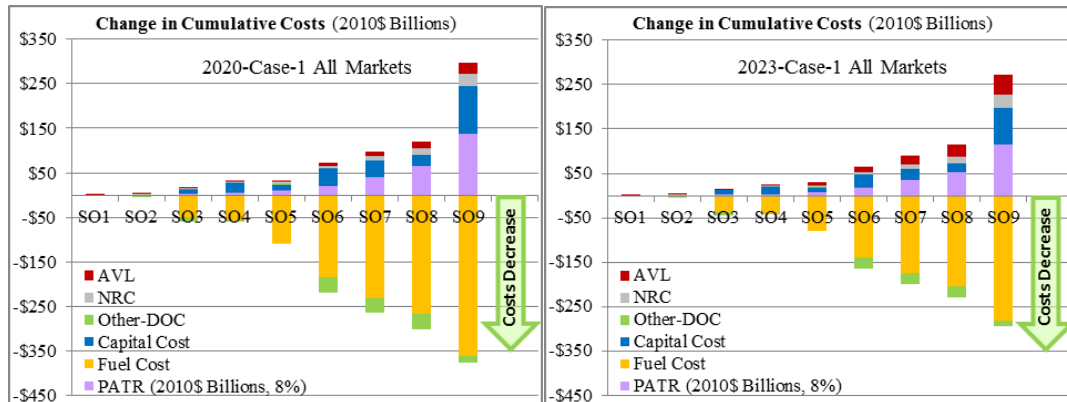

Figure 18a: Change in Cumulative Costs for 2020 and 2023 Case-1 (US2010\$ Billions) Fuel Costs, Capital Costs, Other Direct Operating Costs (DOC), Manufacturer Non-Recurring Costs (NRC) for Technology Response (TR), Owner /Operator Asset Value Loss (AVL) and Price After Technology Response (PATR) from the Implementation Year to 2040

8.8 While PATR and NRC are both shown on the Figure 14a charts that is only to understand the magnitude of the different costs. Because PATR includes both recurring and non-recurring costs associated with an aeroplane receiving a technology response to pass a stringency option, PATR and NRC are never added together for any of the total cost combinations shown in the Figure 18b charts.

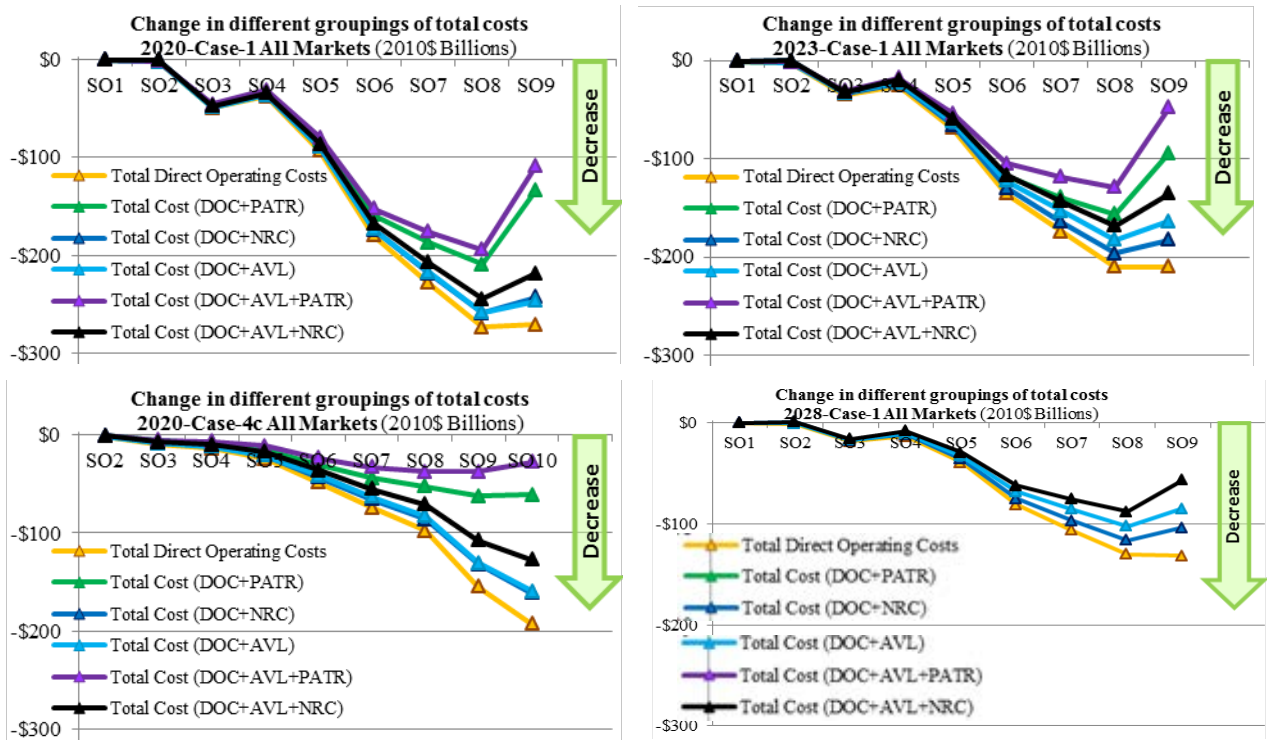

Figure 18b: Change in Different Groupings of Total Costs from the Implementation Year to 2040

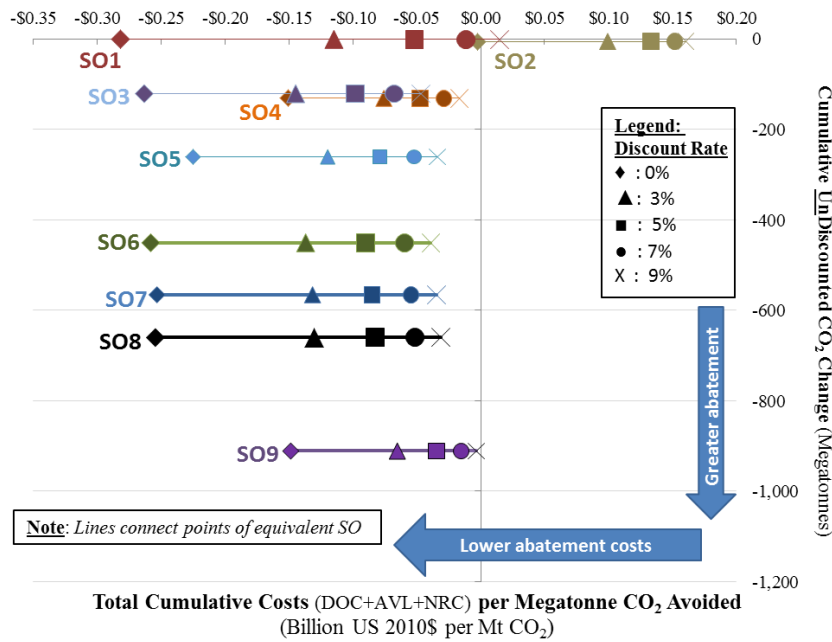

Figure 19: Sensitivity Analysis Results for 2023-Case-1 Change in Total Cumulative Costs (DOC+AVL+NRC) reported with Discount Rate Variation per Un-Discounted Megatonne CO₂ Avoided against cumulative CO₂ Change (Mt) from the Implementation Year to 2040

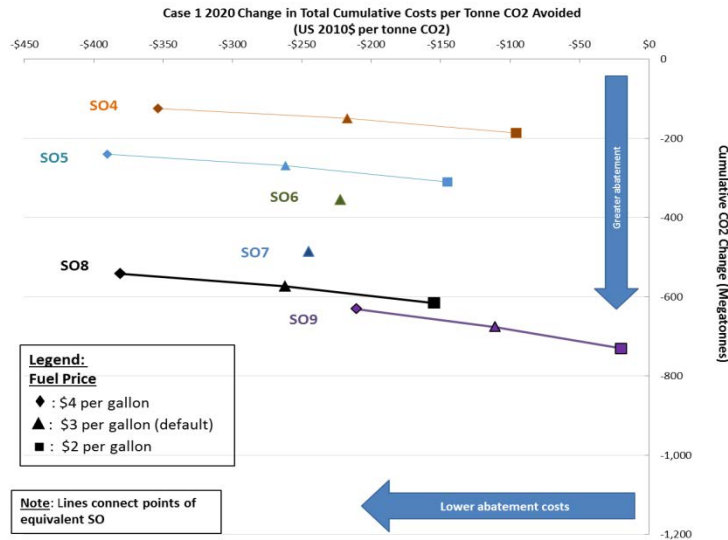

Figure 20: 2020-Case-1 Abatement Cost versus Cumulative CO₂ with \$3, \$2 and \$4 Fuel Prices from the Implementation Year to 2040⁴¹

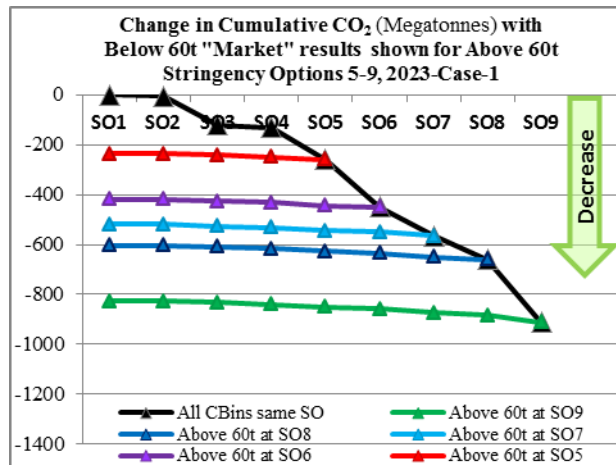

Figure 21: Change in Cumulative CO₂ when above 60 tonne aeroplanes are at SO5 through SO9 and combined with below 60 tonne CBin results at each SO

⁴¹ Note that the fuel price sensitivity was conducted with APMT-Economics. While these values differ slightly from the final CO₂ma results, the SO ranking and trends are the same. Because the final CO₂ma changes did not impact the fleet selection algorithm or fuel price assumptions, which are the primary drivers of the observed changes in the fuel price sensitivity, the results would not be impacted by the final CO₂ma model.

Agenda Item 6: Review of technical proposals relating to aircraft noise**6.1 REPORT OF WG1 – NOISE TECHNICAL**

6.1.1 The co-Rapporteurs of Working Group 1 (WG1, Noise Technical) presented the group's work since CAEP/9. The main aim of WG1 is to keep ICAO noise certification Standards (Annex 16, *Environmental Protection, Volume I – Aircraft Noise*) up to date and effective, while ensuring that the certification procedures are as simple and inexpensive as possible. The CAEP/7 statement on the purpose of noise certification was also reviewed for the benefit of member States. The report provided an overview of progress on each of the work items as related to these objectives.

6.1.2 WG1 presented proposals to revise text in Annex 16, Volume I and ICAO Doc 9501, *Environmental Technical Manual (ETM), Volume I – Procedures for the Noise Certification of Aircraft*, based on the work of the N.02 ad hoc groups. The proposals were endorsed by the 2015 CAEP Steering Group meeting. A summary of these amendments can be found in section 6.2.

6.1.3 During CAEP/10 the NoisedB was updated and extended several times. At the sixth WG1 meeting in October 2015, WG1 agreed to publish Version 2.19 of the ICAO NoisedB. Compared to the previous version (v2.18), changes were incorporated for 161 aeroplanes. DGAC France published NoisedB Version 2.19 on 30 October 2015. Since CAEP/9 1,300 new entries have been added to NoisedB.

6.1.4 WG1 recommended an approach to “review progress towards achievement of Technology Goals” (Task N.04.02) stating a basic criteria (“goal is met when one or more manufacturers achieve a TRL8 performance within the goal band”) and means of assessment (“consider situation of most recent certification figures”). WG1 concluded that the Mid-Term Noise Technology Goals were met for the two higher weight categories (LR4 and LR2). Considering the planned certification dates for upcoming new aircraft programmes, WG1 anticipates that a complete assessment of progress across the board will be available for CAEP/11. WG1 then recommended that the next technology goals review be planned between CAEP/11 (2019) and CAEP/12 (2022). WG1 has also continued to monitor the various national and international research programme goals and milestones (Tasks N.04.01 and N.06.02) and a report on this activity was given.

6.1.5 WG1 reviewed the progress of the Supersonic Task Group (SSTG) that is tasked with four supersonic aeroplane noise related work items (Tasks N.05.01 to N.05.04). On supersonic research, major progress continues in experimental testing and long term planning.

6.1.6 Coordination with other working groups was carried out for the development of technology assumptions for Noise trends and for the development of the CO₂ Standard. The latter occurred through the WG1-WG3-MDG-FESG Liaison Group (WMF). Otherwise, this was a continuous and ongoing task during the CAEP/10 cycle, depending on actual needs.

6.1.7 At the 2013 CAEP Steering Group meeting, WG1 was given the additional task (N.07) to review the status of Unmanned Aircraft (UA) noise certification. The conclusions of the WG1 analysis of the responses to the State letter AN 1/17-14/57 regarding noise certification of UA review were noted by the 2015 CAEP Steering Group meeting and it was agreed that WG1 would work on a lower mass limit for applicability for Annex 16, Volume I Chapters during CAEP/11.

6.1.8 The Technology Task Group (TTG) has addressed as a priority the development of the Helicopter Noise Reduction Technology Status Report. This report was presented to the 2015 CAEP

Steering Group meeting where it was accepted as the fulfilment of the task to review the upcoming helicopter technology advancements. This report has gone through minor editorial changes and is in the process of being published by ICAO.

6.2 PROPOSED AMENDMENTS TO ANNEX 16, VOLUME I AND THE ENVIRONMENTAL TECHNICAL MANUAL, VOLUME I

6.2.1 N.02.01 Definitions; N.02.02 Modification of ETM figures; N.02.04 Nomenclature: Symbols and units; N.02.06 Caretaking of the ETM

6.2.1.1 WG1 recommended changes to the ETM, Volume I and Annex 16, Volume I to enhance the documents' utility and compatibility. Under N.02.06, all miscellaneous editorial changes arising from other N.02 tasks have been included. The maintenance and update task will continue during CAEP/11.

6.2.2 N.02.12 Atmospheric absorption

6.2.2.1 This task is to "Monitor SAE work to update the atmospheric absorption procedure and assess the impact, including the effect on stringency, of its adoption in the Annex". At the 2015 CAEP Steering Group meeting, it was agreed that SAE ARP 5534, for noise certification purposes, would be adopted during the next round of standard-setting at the earliest, pending completion of the technical work. Completion of the technical work is expected during the CAEP/11 cycle.

6.2.3 N.02.14 Confidence interval for interpolation

6.2.3.1 The 2015 CAEP Steering Group meeting endorsed new guidance for applicants and authorities on the calculation of confidence intervals for interpolation between already approved noise/mass values.

6.2.4 N.02.22 Flight path measurement

6.2.4.1 Noise certification flight testing requires that the aircraft's position relative to the microphone(s) be established to a high degree of accuracy. Improved guidance to reflect modern aircraft tracking methods using differential global positioning tracking systems was completed. Related Annex text was aligned with the revised ETM guidance material. These changes were endorsed by the 2015 CAEP Steering Group meeting. Additional work is needed in CAEP/11 to update guidance on photographic scaling methods used by small aircraft.

6.2.5 N.02.25 Recertification taking into account Chapter 14

6.2.5.1 The 2015 CAEP Steering Group meeting endorsed the revisions to the ETM, Volume I, Chapter 9 to introduce guidelines for recertification to Annex 16, Volume I, Chapter 14.

6.2.6 N.02.26 Update of ETM for tilt-rotors

6.2.6.1 The 2015 CAEP Steering Group meeting endorsed guidelines in the ETM for tilt-rotors with reference to the certification standards for tilt-rotors in Annex 16, Volume I, Chapter 13 and the certification guidance for tilt-rotors in Annex 16, Volume I, Attachment F.

Discussion and Conclusions

6.2.7 The meeting congratulated WG1 on its achievements in keeping Annex 16, Volume I up to date and relevant. The meeting approved the amendments to Annex 16, Volume I as presented in Appendix A. The meeting noted the view of a member that a thorough review of the text in Chapter 13 of Annex 16, Volume I is needed and agreed to consider it with future work.

6.2.8 The meeting confirmed the Steering Group Approved Revision (SGAR) of the ETM, Volume I approved by the 2015 CAEP Steering Group meeting.

6.2.9 Recommendation

6.2.9.1 In light of the foregoing discussion, the meeting developed the following recommendation:

RSPP | **Recommendation 6/1 — Amendments to Annex 16 —
Environmental Protection, Volume I — *Aircraft Noise***

That Annex 16, Volume I be amended as indicated in Appendix A to the report on this agenda item.

**Recommendation 6/2 — Amendments to the Environmental
Technical Manual, Volume I – *Procedures for the Noise
Certification of Aircraft***

That the *Environmental Technical Manual*, Volume I be amended, as indicated in the Report of Working Group 1, and revised versions approved by subsequent CAEP Steering Group Meetings be made available, free of charge on the ICAO website, pending a final decision on official publication by the ICAO Secretary General.

6.3 REVIEW OF PROGRESS TOWARDS ACHIEVEMENT OF CAEP/8 TECHNOLOGY GOALS

6.3.1 The co-Rapporteurs of WG1 presented results of work items related to noise research and emerging noise technologies monitoring and Technology Goals Benchmarking.

6.3.2 An overview of worldwide noise technology research initiatives covering a 15-year period (2005-2020) were presented, which showed the renewed commitment of the countries involved.

6.3.3 It was shown that the Mid-Term Noise Technology Goals have been met for the two higher weight categories of aeroplanes (long range quad jet, LR4, and long range twin jet, LR2). Considering the planned certification dates for upcoming new aircraft programmes in the mid-weight categories (regional jet, RJ, and short-medium range jet, SMR2), it was anticipated that a complete picture of progress will be available at CAEP/11. WG1 recommended that the next Independent Experts noise technology goals review be planned for the CAEP/12 cycle. The WG1 co-Rapporteurs informed the meeting that since the last WG1 meeting new data became available that shows that the midterm goal for SMR2 has also been met.

Discussion and Conclusions

6.3.4 Several members and observers presented their views on CAEP work related to subsonic noise. The members addressed the technical work on maintenance of the noise Standards and related ETM. The members also reviewed reports on noise technology and noted the need to keep abreast with the state of the art in the context of the balanced approach. They suggested an Independent Expert review be undertaken during the next CAEP cycle. They also noted that a significant amount of research has been completed on the Open Rotor aircraft and that they considered it was essential to verify whether the goals in terms of certification noise levels set for these aircraft are still realistic. As such they proposed an Independent Expert review on noise be undertaken in the CAEP/11 cycle. With respect to helicopter noise, several members and observers supported an investigation on the feasibility of correlating certification noise levels with operational noise levels and work on hover noise, as proposed by WG1.

6.3.5 A member presented her views on the importance of WG1 noise tasks. In addition to the maintenance of the Annex and ETM, the member considered a number of other ongoing tasks to be of high priority. These include possible updates to the tilt-rotor noise certification Standard, completion of incorporating the ARP 5534 atmospheric absorption model into Annex 16, Volume 1, the helicopter noise assessment tasks recommended for CAEP/11, and the need to ensure that the proper considerations are being made regarding the environmental impact (e.g. noise) of Unmanned Aircraft (UA). The member noted that there were still some unresolved issues concerning the tilt-rotor certification Standard. The meeting noted these views and agreed to support the continued work of WG1 regarding Annex 16 and ETM as they pertain to noise certification (including tiltrotor), helicopter noise and UA. The member reiterated her view that future IE reviews should be handled in an interdependent way, taking into account both noise and fuel burn.

6.3.6 The meeting agreed with WG1 that the goals set for 2020 for long-range 2 and 4 engine aircraft have been met. It also reaffirmed that an essential element of the Balanced Approach is that ICAO continuously reflect state-of-the-art technology in its Standards. As such, the meeting agreed that CAEP needs to be informed about the state-of-the-art noise technology and that the Independent Expert reviews are a crucial source of such information. The meeting acknowledged that the work on monitoring research, technology goals benchmarking and monitoring emerging technologies by WG1 is complete.

6.3.7 Several members and observers emphasized that aircraft noise has an effect on human health, and that these effects were described in the Aviation Noise Impacts white paper prepared by ISG.

6.3.8 The WG1 co-Rapporteurs explained that the noise technology goals benchmarking data is included in NoiseDB which is also used by FESG and MDG to prepare the noise trends assessment. In addition, WG1 reviews the current data in order to develop the technology improvement factors and underpin the noise trends assessment. The meeting thanked WG1 to keeping NoiseDB up-to-date. A member underscored the need for updates of the Independent Experts technical goals review.

6.3.9 The meeting welcomed the recent helicopter noise technology status report and supported the WG1 recommendation to review past evaluations of the hover condition as part of a noise certification scheme. It was further explained that hover is not part of take-off or approach, that hover operations can be for an extended period of time, and that the aircraft in hover operates at high main and tail rotor torque levels. However, accurate hover noise measurements may be difficult to capture and that additional work to fully define the hover condition may be needed.

6.3.10 The meeting saw a need to investigate the feasibility of correlating helicopter certification noise levels with operational noise levels, similar to the studies done for jet aeroplanes, as proposed by WG1.

6.3.11 The meeting discussed the noise certification of Unmanned Aircraft (UA) and whether Annex 16, Volume I is applicable to these aircraft. It was clarified that as there is currently no lower mass limit in the applicability for the Chapters Annex 16, Volume I that UA would be covered by the SARPs. It was clarified that WG1 was given the additional task (N.07) at the 2013 CAEP Steering Group meeting to review the status of UA noise certification. As a result WG1 would work on a lower mass limit for applicability for Annex 16, Volume I Chapters during CAEP/11.

6.4 **PROGRESS ON THE DEVELOPMENT OF A SUPERSONIC AEROPLANE NOISE STANDARD**

6.4.1 The co-Rapporteurs of WG1 reported on progress in the development of a noise certification Standard for supersonic aeroplanes that fly en route above Mach 1. This effort has focused on the sonic boom metric(s) down-selection and supersonic flight test procedures definition. An overview of recent supersonic noise technology research was also presented.

6.4.2 Over the course of CAEP/10, a series of metrics assessments were carried out which resulted in the down-selection to five candidate metrics. The remaining five candidate metrics are:

- Stevens' Mark VII perceived level
- Indoor sonic boom annoyance predictor
- A-weighted sound exposure level
- B-weighted sound exposure level
- E-weighted sound exposure level

These metrics were analysed for the low boom scenario and will require additional study for consideration of Mach cut-off appropriateness. Otherwise, a separate metric may be necessary to quantify the impact of Mach cut-off.

6.4.3 A set of three certification measurement locations were also identified for assessing sonic boom noise. WG1 acknowledged that corrections for off-reference conditions may be difficult or even impossible due to the non-linear nature of supersonic shockwave propagation. For this reason, WG1 expects the supersonic en route noise Standard to incorporate both predictions and measurements. Physical measurements would support predictions and be used for calibration of the predictions. Acoustic ground measurements will likely still be required.

6.4.4 **Update on Sonic Boom Knowledge**

6.4.4.1 The WG1 SSTG Research Focal Points (RFPs) provided a brief overview of many of the developments in supersonic technology since the last RFP briefing at CAEP/9. New literature summarizing the current status of supersonic aircraft technology was noted.

6.4.4.2 The work being conducted in the United States was highlighted including continued development of low sonic boom design tools, subjective testing of sonic boom predictions and community response, and the status of proposed plans for a low boom flight demonstrator. Research funding is in place to improve understanding the perception of sonic booms in the indoor environment.

6.4.4.3 The work being conducted in Japan was highlighted including recent flight tests under the D-SEND#2 program to demonstrate advanced low-boom design concepts, collaborative research on improving sonic boom measurement instrumentation, sonic boom modelling using a sonic boom simulator booth and a test building, and development of new sonic boom prediction codes.

6.4.4.4 The work being conducted in Europe was highlighted including recent laboratory experiments, the development of new instrumentation and measurement techniques, and continued development of sonic boom propagation codes.

6.4.4.5 The work related to supersonic flight being conducted by industry was highlighted including research on understanding the sources of uncertainty in the human response to low amplitude sonic booms, United States industry collaboration with national research centres on concepts for a low boom flight demonstrator, European industry collaboration with national research centres on EU Project RUMBLE in Horizon 2022, and the announcement by Aerion Corporation to build a small supersonic airliner by 2021.

6.4.4.6 The RFPs concluded that there are still many unknowns but that the technology is now ready for development of a low boom flight demonstrator. Future work includes research in indoor boom acceptability, atmospheric turbulence modelling, and Mach cut-off and improvement of sonic boom prediction tools and flight test procedures.

6.4.5 Supersonic Aeroplane Development Projects

6.4.5.1 An observer presented on behalf of WG1 an overview of supersonic aeroplane research by industry organisations aimed at sonic boom mitigation and other enabling technologies to support the introduction of a low boom aeroplane capable of supersonic operation over land. It was explained that several airframe and engine manufacturers are involved in research on civil supersonic aircraft technology. The industry briefings indicated that supersonic operations could be introduced before 2025. Independent studies have estimated the need for 300 to 600 commercial supersonic aeroplanes over a 20-year production cycle. The path to commercial supersonic transport operations will likely come through technology breakthroughs first implemented on smaller aeroplanes with a maximum take-off mass of less than 60 tonnes.

6.4.6 Potential Report to Air Navigation Commission on Supersonic Aircraft

6.4.6.1 The WG1 remit includes a task to inform the Air Navigation Commission (ANC) on noise matters regarding supersonic aircraft. The co-Rapporteurs of WG1 have proposed that a meeting be held as an informal briefing to the Air Navigation Commission (ANC) in 2016.

6.4.6.2 The briefing would consist of the following sections: (1) background; (2) WG1 status on development of noise certification Standards for supersonic aeroplanes en route above Mach 1; (3) noise traits of expected supersonic aircraft including Mach cut-off phenomenon and the need to reaffirm former Circular 126 environmental navigation requirement for supersonic operations over land and sea; (4) an update on both sonic boom research and supersonic aircraft project status; and (5) further meetings with the ANC.

Discussion and Conclusions

6.4.7 Several members and observers presented their views related to the development of supersonic aeroplane noise Standards. They agreed that a combination of measurements and calculations

may be needed to certify a supersonic aircraft. They noted the two different concepts of supersonic aircraft designs, namely the low boom concept and the Mach cut-off concept and considered it essential that the industry mobilises the resources needed to prove that low boom and Mach cut-off concepts reach public acceptance. As such, they requested that CAEP note that non-acoustical elements, out of the scope of a Standard, have to be taken into account to assess the international public acceptability of sonic booms from civil supersonic flight. They considered that community tests addressing acoustical elements should contribute to public acceptability and will help to select and refine metrics if need be. They also considered that WG1 should better understand the Mach cut-off aircraft concept and should assess potential noise annoyance from evanescent waves. The meeting noted the views of the members and observers.

6.4.8 A member presented her views on the importance of WG1 noise tasks related to continued progress on the supersonic aeroplane certification Standard. The member expressed their support for the development of the Standard and endorsed added focus on Mach cut-off as part of the supersonic tasks. The member noted that a prototype with sound signatures that realistically represent what will be experienced is needed to provide the necessary data to prove the effectiveness of proposed sonic boom mitigation concepts. The member has funded community response tests for subsonic aircraft that may be able to inform the work of sonic boom community response tasks. The member also offered resources to support these areas of research in WG1.

6.4.9 The meeting recalled the note in paragraph 12.2 of Annex 16, Volume I (Supersonic aeroplanes – Application for Type Certificate submitted on or after 1 January 1975) which states “Standards and Recommended Practices for these aeroplanes have not been developed. However, the maximum noise levels of the Part that would be applicable to subsonic jet aeroplanes may be used as a guideline. Acceptable levels of sonic boom have not been established and compliance with subsonic noise Standards may not be presumed to permit supersonic flight.” Two member States noted that their position was to require that a supersonic aircraft meet the appropriate subsonic noise standard.

6.4.10 The meeting noted the broad industry interest and investment in civil supersonic aeroplanes and recognized the significant progress in sonic boom mitigation as presented by the RFPs and WG1. They acknowledged the work of WG1 in the development of the supersonic Standards work to date and agreed that WG1 should focus its efforts on the five finalist metrics identified in the down-selection process for low-boom design effort. They also acknowledged that a supersonic noise Standard would most likely include both computer modelling and noise measurements on the ground to verify the models. They encouraged WG1 to continue working on Standards for both low boom and Mach cut-off designs and encouraged States to continue supporting supersonic noise research. In preparation for the discussion regarding future work in this area, a member questioned whether WG1 should consider a wider range of operational scenarios. The meeting also agreed to consider the two potential operational scenarios for supersonic flight identified in the working paper, namely restricted supersonic flight over water only and unrestricted supersonic flight over land, noting that differentiation of land types may be needed. The WG1 co-Rapporteurs expressed a significant sense of urgency to deliver work in this area quickly.

6.4.11 The meeting noted that the 2015 CAEP Steering Group meeting “acknowledged public acceptability of booms is a pre-requisite of a standard for supersonic aircraft” and acknowledged that a low-boom supersonic standard does not guarantee public acceptance of sonic boom from supersonic flight. The meeting also noted that a low boom supersonic demonstrator is needed to provide proof of concept and to support studies on public acceptability.

6.4.12 The meeting agreed that the reporting of the status of supersonic aeroplane projects and the status of supersonic noise certification Standards to the ANC was an important task so that ICAO will be prepared for the certification of project aircraft in the 2020-2025 time frame. Furthermore, the matter

of Mach cut-off will be of particular interest to the ANC as it is both a matter related to operations and certification. The meeting recommended that an informal briefing by Secretariat to the ANC, supported by the Research Focal Points, WG1 co-Rapporteurs, and relevant members of ICCAIA be scheduled in the first half of 2016. The Secretariat highlighted that with the end of civil supersonic flight in 2003, the only work related to supersonic flight is in the area of environment. This briefing will help to inform the other relevant areas within the Organization as well, in order to prepare for civil supersonic operations to resume. The meeting noted that regarding Mach cut-off, WG1 has focussed on text that would be necessary for the amendment of Annex 16, Volume I in the context of type certification. The meeting agreed that Task N.05.03 is complete.

APPENDIX A**PROPOSED AMENDMENTS TO ANNEX 16, VOLUME I**

The text of the amendment is arranged to show deleted text with a line through it and new text highlighted with grey shading, as shown below:

1. ~~Text to be deleted is shown with a line through it.~~ text to be deleted
2. **New text to be inserted is highlighted with grey shading** new text to be inserted
3. ~~Text to be deleted is shown with a line through it~~ followed by the replacement text which is highlighted with grey shading. new text to replace existing text

**TEXT OF PROPOSED AMENDMENT TO THE
INTERNATIONAL STANDARDS AND RECOMMENDED PRACTICES
ENVIRONMENTAL PROTECTION
ANNEX 16
TO THE CONVENTION ON INTERNATIONAL CIVIL AVIATION
VOLUME I
AIRCRAFT NOISE**

...

TABLE OF CONTENTS

	<i>Page</i>
NOMENCLATURE: SYMBOLS AND UNITS	(xi)
Foreword	(xix)

...

NOMENCLATURE: SYMBOLS AND UNITS

Note.— Many of the following definitions and symbols are specific to aircraft noise certification. Some of the definitions and symbols may also apply to purposes beyond aircraft noise certification.

1.1 Velocity

<i>Symbol</i>	<i>Unit</i>	<i>Meaning</i>
c_R	m/s	<i>Reference speed of sound.</i> Speed of sound at reference conditions.
M_{ATR}	—	<i>Helicopter rotor reference advancing blade tip Mach number.</i> The sum of the reference rotor rotational tip speed and the reference speed of the helicopter, divided by the reference speed of sound.
M_H	—	<i>Propeller helical tip Mach number.</i> The square root of the sum of the square of the propeller test rotational tip speed and the square of the test airspeed of the aeroplane, divided by the test speed of sound.

M_{HR}	—	<i>Propeller reference helical tip Mach number.</i> The square root of the sum of the square of the propeller reference rotational tip speed and the square of the reference speed of the aeroplane, divided by the reference speed of sound.
Best R/C	m/s	<i>Best rate of climb.</i> The certificated maximum take-off rate of climb at the maximum power setting and engine speed.
V_{AR}	km/h	<i>Adjusted reference speed.</i> On a non-standard test day, the helicopter reference speed adjusted to achieve the same advancing tip Mach number as the reference speed at reference conditions.
V_{CON}	km/h	<i>Maximum airspeed in conversion mode.</i> The never-exceed airspeed of a tilt-rotor when in conversion mode.
V_G	km/h	<i>Ground speed.</i> The aircraft true velocity relative to the ground.
V_{GR}	km/h	<i>Reference ground speed.</i> The aircraft true velocity relative to the ground in the direction of the ground track under reference conditions. V_{GR} is the horizontal component of the reference aircraft speed V_R .
V_H	km/h	<i>Maximum airspeed in level flight.</i> The maximum airspeed of a helicopter in level flight when operating at maximum continuous power.
V_{MCP}	km/h	<i>Maximum airspeed in level flight.</i> The maximum airspeed of a tilt-rotor in level flight when operating in aeroplane mode at maximum continuous power.
V_{MO}	km/h	<i>Maximum operating airspeed.</i> The maximum operating limit airspeed of a tilt-rotor that may not be deliberately exceeded.
V_{NE}	km/h	<i>Never exceed airspeed.</i> The maximum operating limit airspeed that may not be deliberately exceeded.
V_R	km/h	<i>Reference speed.</i> The aircraft true velocity at reference conditions in the direction of the reference flight path. <i>Note:— This symbol should not be confused with the symbol commonly used for aeroplane take-off rotation speed.</i>
V_{REF}	km/h	<i>Reference landing airspeed.</i> The speed of the aeroplane, in a specific landing configuration, at the point where it descends through the landing screen height in the determination of the landing distance for manual landings.
V_S	km/h	<i>Stalling airspeed.</i> The minimum steady airspeed in the landing configuration.
V_{tip}	m/s	<i>Tip speed.</i> The rotational speed of a rotor or propeller tip at test conditions, excluding the aircraft velocity component.

V_{tipR}	m/s	Reference tip speed. The rotational speed of a rotor or propeller tip at reference conditions, excluding the aircraft velocity component.
V_Y	km/h	<i>Speed for best rate of climb.</i> The test airspeed for best take-off rate of climb.
V_2	km/h	<i>Take-off safety speed.</i> The minimum airspeed for a safe take-off.

1.2 Time

<i>Symbol</i>	<i>Unit</i>	<i>Meaning</i>
t_0	s	<i>Reference duration.</i> The length of time used as a reference in the integration equation for computing EPNL, where $t_0 = 10$ s.
t_R	s	<i>Reference reception time.</i> The reference time of reception calculated from time of reference aircraft position and distance between aircraft and microphone used in the integrated procedure.
Δt	s	<i>Time increment.</i> The equal time increment between one-third octave band spectra, where $\Delta t = 0.5$ s.
δt_R	s	<i>Reference time increment.</i> The effective duration of a time increment between reference reception times associated with PNLT points used in the integrated method.

1.3 Indices

<i>Symbol</i>	<i>Unit</i>	<i>Meaning</i>
i	—	<i>Frequency band index.</i> The numerical indicator that denotes any one of the 24 one-third octave bands with nominal geometric mean frequencies from 50 to 10 000 Hz.
k	—	<i>Time increment index.</i> The numerical indicator that denotes any one of the 0.5 second spectra in a noise time history. For the integrated method, the adjusted time increment associated with each value of k will likely vary from the original 0.5 second time increment when projected to reference conditions.
k_F	—	<i>First time increment identifier.</i> Index of the first 10 dB-down point in the discrete measured PNLT time history.
k_{FR}	—	<i>Reference first time increment identifier.</i> Index of the first 10 dB-down point in the discrete PNLT time history for the integrated method.

<i>Symbol</i>	<i>Unit</i>	<i>Meaning</i>
k_L	—	<i>Last time increment identifier.</i> Index of the last 10 dB-down point in the discrete measured PNL time history.
k_{LR}	—	<i>Reference last time increment identifier.</i> Index of the last 10 dB-down point in the discrete PNL time history for the integrated method.
k_M	—	<i>Maximum PNL time increment index.</i> Time increment index of PNL.
t	s	<i>Elapsed time.</i> The length of time measured from a reference zero.
t_1	s	<i>Time of first 10 dB-down point.</i> The time of the first 10 dB-down point in a continuous function of time. (See k_F .)
t_2	s	<i>Time of last 10 dB-down point.</i> The time of the last 10 dB-down point in a continuous function of time. (See k_L .)

1.4 Noise Metrics

<i>Symbol</i>	<i>Unit</i>	<i>Meaning</i>
EPNL	EPNdB	<i>Effective perceived noise level.</i> A single-number evaluator for an aircraft pass-by, accounting for the subjective effects of aircraft noise on human beings, consisting of an integration over the noise duration of the perceived noise level (PNL) adjusted for spectral irregularities (PNLT), normalized to a reference duration of 10 seconds. (See Appendix 2, Section 4.1 for specifications.)
EPNL _A	EPNdB	<i>Approach EPNL.</i> Effective perceived noise level at the aeroplane approach reference measurement points.
EPNL _F	EPNdB	<i>Flyover EPNL.</i> Effective perceived noise level at the aeroplane flyover reference measurement points.
EPNL _L	EPNdB	<i>Lateral EPNL.</i> Effective perceived noise level at the aeroplane lateral reference measurement points.
L _{AE}	dB SEL	<i>Sound exposure level (SEL).</i> A single event noise level for an aircraft pass-by, consisting of an integration over the noise duration of the A-weighted sound level (dBA), normalized to a reference duration of 1 second. (See Appendix 4, Section 3 for specifications.)
L _{AS}	dB(A)	<i>Slow A-weighted sound level.</i> Sound level with frequency weighting A and time weighting S for a specified instance in time.
L _{ASmax}	dB(A)	<i>Maximum Slow A-weighted sound level.</i> The maximum value of L _{AS} over a specified time interval.

<i>Symbol</i>	<i>Unit</i>	<i>Meaning</i>
L_{ASmaxR}	dB(A)	<i>Reference maximum Slow A-weighted sound level.</i> The maximum value of L_{AS} over a specified time interval corrected to reference conditions.
$LIMIT_A$	EPNdB	<i>Approach EPNL limit.</i> The maximum permitted noise level at the aeroplane approach reference measurement points.
$LIMIT_F$	EPNdB	<i>Flyover EPNL limit.</i> The maximum permitted noise level at the aeroplane flyover reference measurement points.
$LIMIT_L$	EPNdB	<i>Lateral EPNL limit.</i> The maximum permitted noise level at the aeroplane lateral reference measurement points.
n	noy	<i>Perceived noisiness.</i> The perceived noisiness of a one-third octave band sound pressure level in a given spectrum.
N	noy	<i>Total perceived noisiness.</i> The total perceived noisiness of a given spectrum calculated from the 24 values of n .
PNL	PNdB	<i>Perceived noise level.</i> A perception-based noise evaluator representing the subjective effects of broadband noise received at a given point in time during an aircraft pass-by. It is the noise level empirically determined to be equally as noisy as a 1 kHz one-third octave band sample of random noise. (See Appendix 2, Section 4.2 for specifications.)
$PNLT$	TPNdB	<i>Tone-corrected perceived noise level.</i> The value of the PNL of a given spectrum adjusted for spectral irregularities.
$PNLT_R$	TPNdB	<i>Reference tone-corrected perceived noise level.</i> The value of $PNLT$ adjusted to reference conditions.
$PNLTM$	TPNdB	<i>Maximum tone-corrected perceived noise level.</i> The maximum value of $PNLT$ in a specified time history, adjusted for the bandsharing adjustment Δ_B .
$PNLTM_R$	TPNdB	<i>Reference maximum tone-corrected perceived noise level.</i> The maximum value of $PNLT_R$ in a specified time history, adjusted for the bandsharing adjustment Δ_B in the simplified method and Δ_{BR} in the integrated method.
SPL	dB	<i>Sound pressure level.</i> The level of sound, relative to the reference level of 20 μ Pa, at any instant of time that occurs in a specified frequency range. The level is calculated as ten times the logarithm to the base 10 of the ratio of the time-mean-square pressure of the sound to the square of the reference sound pressure of 20 μ Pa.

Note: — Typical aircraft noise certification usage refers to a specific one-third octave band, e.g. $SPL(i,k)$ for the i -th band of the k -th spectrum in an aircraft noise time-history.

<i>Symbol</i>	<i>Unit</i>	<i>Meaning</i>
SPL_R	dB	<i>Reference sound pressure level.</i> The one-third octave band sound pressure levels adjusted to reference conditions.
SPL_S	dB	<i>Slow-weighted sound pressure level.</i> The value of one-third octave band sound pressure levels with time weighting S applied.
Δ_1	TPNdB	<i>PNLTM adjustment.</i> In the simplified adjustment method, the adjustment to be added to the measured EPNL to account for noise level changes due to differences in atmospheric absorption and noise path length between test and reference conditions at PNLTM. For propeller aeroplanes, the adjustment to be added to L_{Amax} to account for noise level changes due to the difference between test and reference aeroplane heights.
Δ_2	TPNdB	<i>Duration adjustment.</i> In the simplified adjustment method, the adjustment to be added to the measured EPNL to account for noise level changes due to the change in noise duration caused by differences between test and reference aircraft speed and position relative to the microphone.
Δ_3	TPNdB	<i>Source noise adjustment.</i> In the simplified or integrated adjustment method, the adjustment to be added to the measured EPNL to account for noise level changes due to differences in source noise generating mechanisms between test and reference conditions.
Δ_4	dB	<i>Atmospheric absorption adjustment.</i> For propeller aeroplanes, the adjustment to be added to the measured L_{Amax} for noise level changes due to the change in atmospheric absorption caused by the difference between test and reference aeroplane heights.
Δ_B	TPNdB	<i>Bandsharing adjustment.</i> The adjustment to be added to the maximum PNLT to account for possible suppression of a tone due to one-third octave bandsharing of that tone. PNLTM is equal to the maximum PNLT plus Δ_B .
Δ_{BR}	TPNdB	<i>Reference bandsharing adjustment.</i> The adjustment to be added to the maximum PNLT _R in the integrated method to account for possible suppression of a tone due to one-third octave bandsharing of that tone. PNLTM _R is equal to the maximum PNLT _R plus Δ_{BR} .
Δ_{peak}	TPNdB	<i>Peak adjustment.</i> The adjustment to be added to the measured EPNL for when the PNLT for a secondary peak, identified in the calculation of EPNL from measured data and adjusted to reference conditions, is greater than the PNLT for the adjusted PNLTM spectrum.

1.5 Calculation of PNL and Tone Correction

<i>Symbol</i>	<i>Unit</i>	<i>Meaning</i>
---------------	-------------	----------------

<i>Symbol</i>	<i>Unit</i>	<i>Meaning</i>
C	dB	<i>Tone correction factor.</i> The factor to be added to the PNL of a given spectrum to account for the presence of spectral irregularities such as tones.
<i>f</i>	Hz	<i>Frequency.</i> The nominal geometric mean frequency of a one-third octave band.
<i>F</i>	dB	<i>Delta-dB.</i> The difference between the original sound pressure level and the final broadband sound pressure level of a one-third octave band in a given spectrum.
$\log n(a)$	—	<i>Noy discontinuity coordinate.</i> The $\log n$ value of the intersection point of the straight lines representing the variation of SPL with $\log n$.
<i>M</i>	—	<i>Noy inverse slope.</i> The reciprocals of the slopes of straight lines representing the variation of SPL with $\log n$.
<i>s</i>	dB	<i>Slope of sound pressure level.</i> The change in level between adjacent one-third octave band sound pressure levels in a given spectrum.
Δs	dB	<i>Change in slope of sound pressure level.</i>
<i>s'</i>	dB	<i>Adjusted slope of sound pressure level.</i> The change in level between adjacent adjusted one-third octave band sound pressure levels in a given spectrum.
\bar{s}	dB	<i>Average slope of sound pressure level.</i>
SPL(a)	dB	<i>Noy discontinuity level.</i> The SPL value at the discontinuity coordinate of the straight lines representing the variation of SPL with $\log n$.
SPL(b) SPL(c)	dB	<i>Noy intercept levels.</i> The intercepts on the SPL-axis of the straight lines representing the variation of SPL with $\log n$.
SPL(d)	dB	<i>Noy discontinuity level.</i> The SPL value at the discontinuity coordinate where $\log n$ equals -1 .
SPL(e)	dB	<i>Noy discontinuity level.</i> The SPL value at the discontinuity coordinate where $\log n$ equals $\log 0.3$.
SPL'	dB	<i>Adjusted sound pressure level.</i> The first approximation to broadband sound pressure level in a one-third octave band of a given spectrum.
SPL''	dB	<i>Final broadband sound pressure level.</i> The second and final approximation to broadband sound pressure level in a one-third octave band of a given spectrum.

1.6 Flight Path Geometry

<i>Symbol</i>	<i>Unit</i>	<i>Meaning</i>
H	m	<i>Height.</i> The aircraft height when overhead or abeam of the centre microphone.
H _R	m	<i>Reference height.</i> The reference aircraft height when overhead or abeam of the centre microphone.
X	m	<i>Aircraft position along the ground track.</i> The position coordinate of the aircraft along the x-axis at a specific point in time.
Y	m	<i>Lateral aircraft position relative to the reference ground track.</i> The position coordinate of the aircraft along the y-axis at a specific point in time.
Z	m	<i>Vertical aircraft position relative to the reference ground track.</i> The position coordinate of the aircraft along the z-axis at a specific point in time.
θ	degrees	<i>Sound emission angle.</i> The angle between the flight path and the direct sound propagation path to the microphone. The angle is identical for both the measured and reference flight paths.
ψ	degrees	<i>Elevation angle.</i> The angle between the sound propagation path and a horizontal plane passing through the microphone, where the sound propagation path is defined as a line between a sound emission point on the measured flight path and the microphone diaphragm.
ψ _R	degrees	<i>Reference elevation angle.</i> The angle between the reference sound propagation path and a horizontal plane passing through the reference microphone location, where the reference sound propagation path is defined as a line between a sound emission point on the reference flight path and the reference microphone diaphragm.

1.7 Miscellaneous

<i>Symbol</i>	<i>Unit</i>	<i>Meaning</i>
antilog	—	<i>Antilogarithm to the base 10.</i>
D	m	<i>Diameter.</i> Propeller or rotor diameter.
D ₁₅	m	<i>Take-off distance.</i> The take-off distance required for an aeroplane to reach 15 m height above ground level.
e	—	<i>Euler's number.</i> The mathematical constant that is the base number of the natural logarithm, approximately 2.7183.

<i>Symbol</i>	<i>Unit</i>	<i>Meaning</i>
log	—	<i>Logarithm to the base 10.</i>
N	rpm	<i>Propeller speed.</i>
N ₁	rpm	<i>Compressor speed.</i> The turbine engine low pressure compressor first stage fan speed.
RH	%	<i>Relative humidity.</i> The ambient atmospheric relative humidity.
T	°C	<i>Temperature.</i> The ambient atmospheric temperature.
u	m/s	<i>Wind speed along-track component.</i> The component of the wind speed vector along the reference ground track.
v	m/s	<i>Wind speed cross-track component.</i> The component of the wind speed vector horizontally perpendicular to the reference ground track.
α	dB/100 m	<i>Test atmospheric absorption coefficient.</i> The sound attenuation rate due to atmospheric absorption that occurs in a specified one-third octave band for the measured ambient temperature and relative humidity.
α _R	dB/100 m	<i>Reference atmospheric absorption coefficient.</i> The sound attenuation rate due to atmospheric absorption that occurs in a specified one-third octave band for a reference ambient temperature and relative humidity.
μ	—	<i>Engine noise performance parameter.</i> For jet aeroplanes, typically the normalized low pressure fan speed, normalized engine thrust, or engine pressure ratio used in the calculation of the source noise adjustment.

...

PART I. DEFINITIONS

...

~~Auxiliary power unit~~ **Auxiliary power unit (APU).** A self-contained power unit on an aircraft providing electrical/pneumatic power to aircraft systems during ground operations.

...

State of Registry. The State on whose register the aircraft is entered.

...

CHAPTER 3.

1.— SUBSONIC JET AEROPLANES — Application for Type Certificate submitted on or after 6 October 1977 and before 1 January 2006

2.— **PROPELLER-DRIVEN AEROPLANES OVER 8 618 kg — Application for Type Certificate submitted on or after 1 January 1985 and before 1 January 2006**

...

3.6 Noise certification reference procedures

...

3.6.1.5 The reference procedures shall be calculated under the following reference atmospheric conditions:

- a) ~~sea level~~ atmospheric pressure at sea level of 1 013.25 hPa, decreasing with altitude at a rate defined by the ICAO Standard Atmosphere;
- b) ambient air temperature at sea level of 25°C, ~~i.e. ISA + 10°C~~; decreasing with altitude at a rate defined by the ICAO Standard Atmosphere (i.e. 0.65°C per 100 m);
- c) ~~constant~~ relative humidity of 70 per cent;
- d) zero wind; ~~and~~
- e) for the purpose of defining the reference take-off profiles for both take-off and lateral noise measurements, the runway gradient is zero; ~~and~~
- f) the reference atmosphere in terms of temperature and relative humidity is considered to be homogeneous (i.e. ambient temperature 25°C and relative humidity 70 per cent) for the purpose of calculating:
 - 1) the reference sound attenuation rate due to atmospheric absorption; ~~and~~
 - 2) the reference speed of sound used in the calculation of the reference sound propagation geometry.

Note 1. —~~The reference atmosphere in terms of temperature and relative humidity is homogeneous when used for the calculation of atmospheric absorption coefficients. Details for calculating the variation of reference atmospheric pressure with altitude are given in the section of the Environmental Technical Manual (Doc 9501), Volume I — Procedures for the Noise Certification of Aircraft, concerning the ICAO Standard Atmosphere.~~

Note 2. —~~The characteristics of the ICAO Standard Atmosphere are specified in the Manual of the ICAO Standard Atmosphere (Doc 7488/3).~~

...

3.6.3 Approach reference procedure

The approach reference flight path shall be calculated as follows:

- a) the aeroplane shall be stabilized and following a 3° glide path;
- b) a steady approach speed of $V_{REF} + 19$ km/h ($V_{REF} + 10$ kt), with thrust or power stabilized, shall

be maintained over the measurement point;

Note.— In airworthiness terms V_{REF} is defined as the “reference landing speed”. Under this definition reference landing speed means “the speed of the aeroplane, in a specified landing configuration, at the point where it descends through the landing screen height in the determination of the landing distance for manual landings”.

...

**CHAPTER 5. PROPELLER-DRIVEN AEROPLANES OVER
8 618 kg — Application for Type Certificate submitted
before 1 January 1985**

...

5.6 Noise certification reference procedures

...

5.6.1.5 The reference procedures shall be calculated under the following reference atmospheric conditions:

- a) ~~sea level~~ atmospheric pressure at sea level of 1 013.25 hPa, decreasing with altitude at a rate defined by the ICAO Standard Atmosphere;
- b) ambient air temperature at sea level of 25°C, decreasing with altitude at a rate defined by the ICAO Standard Atmosphere (i.e. 0.65°C per 100 m), ~~i.e. ISA + 10°C~~ except that at the discretion of the certifying authority, an alternative ~~reference~~ ambient air temperature at sea level of 15°C; ~~i.e. ISA~~ may be used;
- c) ~~constant~~ relative humidity of 70 per cent; ~~and~~
- d) zero wind; ~~and~~
- e) the reference atmosphere in terms of temperature and relative humidity is considered to be homogeneous (i.e. ambient temperature 25°C and relative humidity 70 per cent) for the purpose of calculating:
 - 1) the reference sound attenuation rate due to atmospheric absorption; and
 - 2) the reference speed of sound used in the calculation of the reference sound propagation geometry.

Note 1.— Details for calculating the variation of reference atmospheric pressure with altitude are given in the section of the Environmental Technical Manual (Doc 9501), Volume I — Procedures for the Noise Certification of Aircraft, concerning the ICAO Standard Atmosphere.

Note 2. — The characteristics of the ICAO Standard Atmosphere are specified in the Manual of the ICAO Standard Atmosphere (Doc 7488/3).

...

CHAPTER 6. PROPELLER-DRIVEN AEROPLANES
NOT EXCEEDING 8 618 kg — Application for
Type Certificate submitted before 17 November 1988

...

6.4 Noise certification reference procedures

The reference procedure shall be calculated under the following reference atmospheric conditions:

- a) ~~sea level~~ atmospheric pressure at sea level of 1 013.25 hPa, decreasing with altitude at a rate defined by the ICAO Standard Atmosphere; and
- b) ambient air temperature at sea level of 25°C, i.e. ISA + 10°C; decreasing with altitude at a rate defined by the ICAO Standard Atmosphere (i.e. 0.65°C per 100 m);

Note 1.— Details for calculating the variation of reference atmospheric pressure with altitude are given in the section of the Environmental Technical Manual (Doc 9501), Volume I — Procedures for the Noise Certification of Aircraft, concerning the ICAO Standard Atmosphere.

Note 2.— The characteristics of the ICAO Standard Atmosphere are specified in the Manual of the ICAO Standard Atmosphere (Doc 7488/3).

...

6.5 Test procedures

6.5.1 Either the test procedures described in 6.5.2 and 6.5.3 or equivalent test procedures approved by the certifying authority shall be used.

6.5.2 Tests to demonstrate compliance with the maximum noise levels of 6.3 shall consist of a series of level flights overhead the measuring station at a height of

$$\begin{array}{c} 300^{+10} \\ -30 \end{array} \text{ m (985}^{+30} \\ -100 \text{ ft)}$$

$$\begin{array}{c} 300^{+10} \\ -30 \end{array} \text{ m (984}^{+30} \\ -100 \text{ ft)}$$

...

CHAPTER 8. HELICOPTERS

...

8.6.1 General conditions

...

8.6.1.5 The reference procedures shall be ~~established for~~ calculated under the following reference atmospheric conditions:

- a) ~~sea level~~ constant atmospheric pressure of 1 013.25 hPa;

- b) constant ambient air temperature of 25°C, i.e. ISA + 10°C;
- c) constant relative humidity of 70 per cent; and
- d) zero wind.

...

8.6.2 Take-off reference procedure

The take-off reference flight procedure shall be established as follows:

- a) the helicopter shall be stabilized at the maximum take-off power corresponding to minimum installed engine(s) specification power available for the reference ambient conditions or gearbox torque limit, whichever is lower, and along a path starting from a point located 500 m prior to the flight path reference point, at 20 m (65 ft) above the ground;
- b) the best rate of climb speed, V_y V_Y , or the lowest approved speed for the climb after take-off, whichever is the greater, shall be maintained throughout the take-off reference procedure;
- c) the steady climb shall be made with the rotor speed stabilized at the maximum normal operating rpm certificated for take-off;
- d) a constant take-off configuration selected by the applicant shall be maintained throughout the take-off reference procedure with the landing gear position consistent with the airworthiness certification tests for establishing the best rate of climb speed, V_y V_Y ;
- e) the mass of the helicopter shall be the maximum take-off mass at which noise certification is requested; and
- f) the reference take-off path is defined as a straight line segment inclined from the starting point (500 m prior to the centre microphone location and 20 m (65 ft) above ground level) at an angle defined by best rate of climb and V_y V_Y for minimum specification engine performance.

8.6.3 Overflight reference procedure

8.6.3.1 The overflight reference procedure shall be established as follows:

- a) the helicopter shall be stabilized in level flight overhead the flight path reference point at a height of 150 m (492 ft);
- b) a speed of $0.9 V_H$ or $0.9 V_{NE}$ or $0.45 V_H + 120$ km/h ($0.45 V_H + 65$ kt) or $0.45 V_{NE} + 120$ km/h ($0.45 V_{NE} + 65$ kt), whichever is the least, shall be maintained throughout the overflight reference procedure;

Note.— For noise certification purposes, V_H V_H is defined as the airspeed in level flight obtained using the torque corresponding to minimum engine installed, maximum continuous power available for sea level pressure (1 013.25 hPa), 25°C ambient conditions at the relevant maximum certificated mass. V_{NE} V_{NE} is defined as the not-to-exceed airworthiness airspeed imposed by the manufacturer and approved by the certifying authority.

- c) the overflight shall be made with the rotor speed stabilized at the maximum normal operating rpm certificated for level flight;
- d) the helicopter shall be in the cruise configuration; and
- e) the mass of the helicopter shall be the maximum take-off mass at which noise certification is requested.

8.6.3.2 The value of V_H and/or V_{NE} used for noise certification shall be quoted in the approved flight manual.

8.6.4 Approach reference procedure

The approach reference procedure shall be established as follows:

- a) the helicopter shall be stabilized and following a 6.0° approach path;
- b) the approach shall be made at a stabilized airspeed equal to the best rate of climb speed, V_y , V_Y , or the lowest approved speed for the approach, whichever is the greater, with power stabilized during the approach and over the flight path reference point, and continued to a normal touchdown;

...

CHAPTER 10. PROPELLER-DRIVEN AEROPLANES NOT EXCEEDING 8 618 kg — Application for Type Certificate or Certification of Derived Version submitted on or after 17 November 1988

...

10.2 Noise evaluation measure

The noise evaluation measure shall be the maximum A-weighted noise level (L_{Amax}), L_{ASmax} , as defined in Appendix 6.

...

10.5.1 General conditions

...

10.5.1.4 The reference procedures shall be calculated under the following atmospheric conditions:

- a) ~~sea level~~ atmospheric pressure at sea level of 1 013.25 hPa, decreasing with altitude at a rate defined by the ICAO Standard Atmosphere;
- b) ambient air temperature at sea level of 15°C , ~~i.e. ISA~~ decreasing with altitude at a rate defined by the ICAO Standard Atmosphere (i.e. 0.65°C per 100 m);

- c) constant relative humidity of 70 per cent; and
- d) zero wind.

Note 1.— Details for calculating the variation of reference atmospheric pressure with altitude are given in the section of the Environmental Technical Manual (Doc 9501), Volume I — Procedures for the Noise Certification of Aircraft, concerning the ICAO Standard Atmosphere.

Note 2.— The characteristics of the ICAO Standard Atmosphere are specified in the Manual of the ICAO Standard Atmosphere (Doc 7488/3).

10.5.1.5 The acoustic reference atmospheric conditions shall be the same as the reference atmospheric conditions for flight.

10.5.2 Take-off reference procedure

...

Second phase

- a) the beginning of the second phase corresponds to the end of the first phase;
- b) the aeroplane shall be in the climb configuration with landing gear up, if retractable, and flap setting corresponding to normal climb throughout this second phase;
- c) the speed shall be the best rate of climb speed, V_y V_Y ; and
- d) take-off power and, for aeroplanes equipped with variable pitch or constant speed propellers, rpm shall be maintained throughout the second phase. If airworthiness limitations do not permit the application of take-off power and rpm up to the reference point, then take-off power and rpm shall be maintained for as long as is permitted by such limitations and thereafter at maximum continuous power and rpm. Limiting of time for which take-off power and rpm shall be used in order to comply with this chapter shall not be permitted. The reference height shall be calculated assuming climb gradients appropriate to each power setting used.

10.6 Test procedures

10.6.1 The test procedures shall be acceptable to the airworthiness and noise certifying authorities of the State issuing the certificate.

10.6.2 The test procedures and noise measurements shall be conducted and processed in an approved manner to yield the noise evaluation measure in units of L_{Amax} L_{ASmax} as described in Appendix 6.

...

...

**CHAPTER 11. HELICOPTERS NOT EXCEEDING 3 175 kg
MAXIMUM CERTIFICATED TAKE-OFF MASS**

...

11.5.1 General conditions

...

11.5.1.4 The reference procedure shall be established for the following reference atmospheric conditions:

- a) ~~sea level~~ constant atmospheric pressure of 1 013.25 hPa;
- b) constant ambient air temperature of 25°C;
- c) constant relative humidity of 70 per cent; and
- d) zero wind.

...

CHAPTER 13. TILT-ROTORS

...

13.2 Noise evaluation measure

The noise evaluation measure shall be the effective perceived noise level in EPNdB as described in Appendix 2 of this Annex. The correction for spectral irregularities shall start at 50 Hz (see 4.3.1 of Appendix 2).

Note.— Additional data in SEL and L_{ASmax} as defined in Appendix 4, and one-third octave SPLs as defined in Appendix 2 corresponding to L_{Amax} L_{ASmax} should be made available to the certifying authority for land-use planning purposes.

13.3 Noise measurement reference points

A tilt-rotor, when tested in accordance with the reference procedures of ~~Section 6~~ 13.6 and the test procedures of ~~Section 7~~ 13.7, shall not exceed the noise levels specified in 13.4 at the following reference points:

...

13.6 Noise certification reference procedures

...

13.6.1.5 The reference procedures shall be established for calculated under the following reference atmospheric conditions:

- a) sea level constant atmospheric pressure of 1 013.25 hPa;
- b) constant ambient air temperature of 25°C, i.e. ISA + 10°C;
- c) constant relative humidity of 70 per cent; and
- d) zero wind.

...

13.6.2 Take-off reference procedure

The take-off reference flight procedure shall be established as follows:

...

- f) the reference take-off path is defined as a straight line segment inclined from the starting point (500 m (1 640 ft) prior to the centre noise measurement point and 20 m (65 ft) above ground level) at an angle defined by best rate of climb (BRC) and the best rate of climb speed corresponding to the selected nacelle angle and for minimum specification engine performance.

...

13.6.3 Overflight reference procedure

13.6.3.1 The overflight reference procedure shall be established as follows:

...

- d) in the VTOL/conversion mode, the nacelle angle at the authorized fixed operation point that is closest to the lowest nacelle angle certificated for zero airspeed, a speed of $0.9V_{CON}$ and a rotor speed stabilized at the maximum normal operating rpm certificated for level flight shall be maintained throughout the overflight reference procedure;

Note.— For noise certification purposes, V_{CON} is defined as the maximum authorized speed for VTOL/conversion mode at a specific nacelle angle.

- e) in the aeroplane mode, the nacelles shall be maintained on the down-stop throughout the overflight reference procedure, with:
 - 1) rotor speed stabilized at the rpm associated with the VTOL/conversion mode and a speed of $0.9V_{CON}$; and
 - 2) rotor speed stabilized at the normal cruise rpm associated with the aeroplane mode and at the corresponding $0.9V_{MCP}$ or $0.9V_{MO}$, whichever is lesser, certificated for level flight.

...

APPENDIX 2. EVALUATION METHOD FOR NOISE CERTIFICATION OF:

- 1.— SUBSONIC JET AEROPLANES — Application for Type Certificate submitted on or after 6 October 1977
- 2.— PROPELLER-DRIVEN AEROPLANES OVER 8 618 kg — Application for Type Certificate submitted on or after 1 January 1985
- 3.— HELICOPTERS
- 4.— TILT-ROTORS

Note.— See Part II, Chapters 3, 4, 8, 13 and 14.

1. INTRODUCTION

...

Note 3.— A complete list of symbols and units, ~~the~~ is included after the Table of Contents of this Annex. The mathematical formulation of perceived noisiness, a procedure for determining atmospheric attenuation of sound, and detailed procedures for correcting noise levels from non-reference to reference conditions are included in Sections ~~6 to~~ 7 and 8 of this appendix.

...

2.2.2 Atmospheric conditions

2.2.2.1 Definitions and specifications

For the purposes of noise certification in this section the following specifications apply:

Average crosswind component shall be determined from the series of individual values of the “~~cross track~~ cross-track” (v) component of the wind samples obtained during the aircraft test run, using a linear averaging process over 30 seconds or an averaging process that has a time constant of no more than 30 seconds, the result of which is read out at a moment approximately 15 seconds after the time at which the aircraft passes either over or abeam the microphone.

Average wind speed shall be determined from the series of individual wind speed samples obtained during the aircraft test run, using a linear averaging process over 30 seconds, or an averaging process that has a time constant of no more than 30 seconds, the result of which is read out at a moment approximately 15 seconds after the time at which the aircraft passes either over or abeam the microphone. Alternatively, each wind vector shall be broken down into its “~~along track~~ along-track”

(u) and “cross-track” (v) components. The u and v components of the series of individual wind samples obtained during the aircraft test run shall be separately averaged using a linear averaging process over 30 seconds, or an averaging process that has a time constant of no more than 30 seconds, the result of which is read out at a moment approximately 15 seconds after the time at which the aircraft passes either over or abeam the microphone. The average wind speed and direction (with respect to the track) shall then be calculated from the averaged u and v components according to Pythagorean Theorem and “ $\arctan(v/u)$ ”.

Distance constant (or response length). The passage of wind (in metres) required for the output of a wind speed sensor to indicate $100 \times (1-1/e)$ per cent (about 63 per cent) of a step-function increase of the input speed.

Maximum crosswind component. The maximum value within the series of individual values of the “~~cross track~~ cross-track” (v) component of the wind samples recorded every second over a time interval that spans the 10 dB-down period.

Maximum wind speed. The maximum value within the series of individual wind speed samples recorded every second over a time interval that spans the 10 dB-down period.

Sound attenuation coefficient. The reduction in level of sound within a one-third octave band, in dB per 100 metres, due to the effects of atmospheric absorption of sound. Equations for the calculation of sound attenuation coefficients from values of atmospheric temperature and relative humidity are provided in Section 7.

Time constant (of a first order system). The time required for a device to detect and indicate $100 \times (1-1/e)$ per cent (about 63 per cent) of a step function change. (The mathematical constant, e , is the base number of the natural logarithm, approximately 2.7183 — also known as Euler’s number, or Napier’s constant.)

...

2.3 Flight path measurement

2.3.1 The aircraft ~~height and lateral~~ spatial position relative to the ~~flight track~~ measurement microphone(s) shall be determined by a method which is approved by the certifying authority and is independent of ~~normal cockpit flight instrumentation, such as radar tracking, theodolite triangulation or photographic scaling techniques, to be approved by the certifying authority.~~

Note.— Guidance material on aircraft position measurement systems is provided in the Environmental Technical Manual (Doc 9501), Volume I — Procedures for the Noise Certification of Aircraft.

2.3.2 The aircraft position along the flight path shall be ~~related~~ synchronized to the noise recorded at the noise measurement locations by means of ~~time-synchronizing signals over a distance and duration sufficient to assure that adequate data is obtained during the period that the noise is within 10 dB of the maximum value of PNLT.~~

...

3.1 Definitions

...

Free-field sensitivity of a microphone system. In volts per pascal, for a sinusoidal plane progressive sound wave of specified frequency, at a specified ~~sound incident~~ sound-incidence angle, the quotient of the root-mean-square voltage at the output of a microphone system and the root-mean-square sound pressure that would exist at the position of the microphone in its absence.

...

3.7 Analysis systems

3.7.5 When the one-third octave band sound pressure levels are determined from the output of the analyser without SLOW-time-weighting, SLOW-time-weighting shall be simulated in the subsequent processing. Simulated SLOW-weighted sound pressure levels can be obtained using a continuous exponential averaging process by the following equation:

$$L_s(i,k) = 10 \log [(0.60653) 10^{0.1L_s[i,(k-1)]} + (0.39347) 10^{0.1L(i,k)}]$$

$$SPL_s(i,k) = 10 \log [(0.60653) 10^{0.1SPL_s[i,(k-1)]} + (0.39347) 10^{0.1SPL(i,k)}]$$

where $L_s(i,k)$ $SPL_s(i,k)$ is the simulated SLOW-weighted sound pressure level and $L(i,k)$ $SPL(i,k)$ is the as-measured 0.5 seconds time average sound pressure level determined from the output of the analyser for the k -th instant of time and the i -th one-third octave band. For $k = 1$, the SLOW-weighted sound pressure $L_s[i,(k-1=0)]$ $SPL_s[i,(k-1=0)]$ on the right-hand side shall be set to 0 dB.

An approximation of the continuous exponential averaging is represented by the following equation for a four sample averaging process for $k = 4$:

$$L_s(i,k) = 10 \log [(0.13) 10^{0.1L[i,(k-3)]} + (0.21) 10^{0.1L[i,(k-2)]} + (0.27) 10^{0.1L[i,(k-1)]} + (0.39) 10^{0.1L(i,k)}]$$

$$SPL_s(i,k) = 10 \log [(0.13) 10^{0.1SPL[i,(k-3)]} + (0.21) 10^{0.1SPL[i,(k-2)]} + (0.27) 10^{0.1SPL[i,(k-1)]} + (0.39) 10^{0.1SPL(i,k)}]$$

where $L_s(i,k)$ $SPL_s(i,k)$ is the simulated SLOW-weighted sound pressure level and $L(i,k)$ $SPL(i,k)$ is the as-measured 0.5 seconds time average sound pressure level determined from the output of the analyser for the k -th instant of time and the i -th one-third octave band.

...

4.1 General

...

4.1.3 The calculation procedure which utilizes physical measurements of noise to derive the EPNL evaluation measure of subjective response shall consist of the five following steps:

- a) each of the 24 one-third octave band sound pressure levels in each measured one-half second spectrum is converted to perceived noisiness by the method of Section 4.7. The noy values are combined and then converted to instantaneous perceived noise level, PNL(k) for each spectrum, measured at the k -th instant of time, by the method of Section 4.2;
- b) for each spectrum a tone correction factor, ~~$C(k)$~~ $C(k)$, is calculated by the method of Section 4.3 to account for the subjective response to the presence of spectral irregularities;

- c) the tone correction factor is added to the perceived noise level to obtain the tone corrected perceived noise level, $PNLT(k)$, for each spectrum:

$$PNLT(k) = PNL(k) + C(k);$$

...

4.2 Perceived noise level

...

Note.— Perceived noise level, $PNL(k)$, as a function of total perceived noisiness is plotted in the section of the Environmental Technical Manual (Doc 9501), Volume I — Procedures for the Noise Certification of Aircraft, concerning reference tables used in the manual calculation of effective perceived noise level.

4.3 Correction for spectral irregularities

4.3.1 Noise having pronounced spectral irregularities (for example, the maximum discrete frequency components or tones) shall be adjusted by the correction factor, $C(k)$, calculated as follows:

...

Table A2-2. Tone correction factors

...

Frequency f , Hz	Level difference F , dB	Tone correction C , dB
-----------------------	------------------------------	-----------------------------

...

Tone corrected perceived noise levels $PNLT(k)$ shall be determined by adding the $C(k)$ values to corresponding $PNL(k)$ values, that is:

$$PNLT(k) = PNL(k) + C(k)$$

For any i -th one-third octave band, at any k -th increment of time, for which the tone correction factor is suspected to result from something other than (or in addition to) an actual tone (or any spectral irregularity other than aircraft noise), an additional analysis may be made using a filter with a bandwidth narrower than one-third of an octave. If the narrow band analysis corroborates these suspicions, then a revised value for the broadband sound pressure level, $SPL'(i,k)$, shall be determined from the narrow band analysis and used to compute a revised tone correction factor for that particular one-third octave band.

Note.— Other methods of rejecting spurious tone corrections such as those described in ~~Appendix 2 Chapter 4~~ of the Environmental Technical Manual (Doc 9501), Volume I — Procedures for the Noise Certification of Aircraft may be used.

...

4.4 Maximum tone corrected perceived noise level

...

4.4.2 The tone at PNLTM may be suppressed due to one-third octave bandsharing of that tone. To identify whether this is the case, the average of the tone correction factors of the PNLTM spectrum and the two preceding and two succeeding spectra is calculated. If the value of the tone correction factor $C(k_M)$ for the spectrum associated with PNLTM is less than the average value of $C(k)$ for the five consecutive spectra (k_M-2) through (k_M+2), then the average value C_{avg} shall be used to compute a bandsharing adjustment, Δ_B , and a value of PNLTM adjusted for bandsharing.

$$C_{avg} = [C(k_M-2) + C(k_M-1) + C(k_M) + C(k_M+1) + C(k_M+2)] / 5$$

If $C_{avg} > C(k_M)$, then $\Delta_B = C_{avg} - C(k_M)$ and

...

4.6 Effective perceived noise level

4.6.1 If the instantaneous tone corrected perceived noise level is expressed in terms of a continuous function with time, $PNLT(t)$, then the effective perceived noise level, EPNL, would be defined as the level, in EPNdB, of the time integral of $PNLT(t)$ over the noise event duration, T_0 , of 10 seconds. The noise event duration is bounded by t_1 , the time when $PNLT(t)$ is first equal to $PNLTM - 10$, and t_2 , the time when $PNLT(t)$ is last equal to $PNLTM - 10$.

$$EPNL = 10 \log \frac{1}{T_0} \int_{t_1}^{t_2} 10^{0.1 PNL T(t)} dt$$

$$EPNL = 10 \log \frac{1}{t_0} \int_{t_1}^{t_2} 10^{0.1 PNL T(t)} dt$$

4.6.2 In practice $PNLT$ is not expressed as a continuous function with time since it is computed from discrete values of $PNLT(k)$ every half second. In this case the basic working definition for EPNL is obtained by replacing the integral in Section 4.6.1 with the following summation expression:

$$EPNL = 10 \log \frac{1}{T_0} \sum_{k_F}^{k_E} 10^{0.1 PNL T(k)} \Delta t$$

$$EPNL = 10 \log \frac{1}{t_0} \sum_{k_F}^{k_L} 10^{0.1 PNL T(k)} \Delta t$$

For $T_0 = 10$ and $\Delta t = 0.5$, this expression can be simplified as follows:

$$EPNL = 10 \log \sum_{k_F}^{k_L} 10^{0.1 PNL T(k)} - 13$$

Note.— 13 dB is a constant relating the one-half second values of ~~PNLT(k)~~ PNL $T(k)$ to the 10-second reference duration T_0 : $10 \log (0.5/10) = -13$.

...

Table A2-3. Constants for mathematically formulated noy values

BAND (i)	f Hz	SPL(a)	SPL(b)	SPL(c)	SPL(d)	SPL(e)	M(b)	M(c)	M(d)	M(e)
1	50	91.0	64	52	49	55	0.043478	0.030103	0.079520	0.058098
2	63	85.9	60	51	44	51	0.040570	↑	0.068160	"
3	80	87.3	56	49	39	46	0.036831		"	0.052288
4	100	79.0	53	47	34	42	"	↓	0.059640	0.047534
5	125	79.8	51	46	30	39	0.035336		0.053013	0.043573
6	160	76.0	48	45	27	36	0.033333	↑	0.053013	"
7	200	74.0	46	43	24	33	"			0.040221
8	250	74.9	44	42	21	30	0.032051	↓	0.053013	0.037349
9	315	94.6	42	41	18	27	0.030675			<u>0.030103</u>
10	400	∞	40	40	16	25	0.030103	↑	NOT APPLICABLE	0.053013
11	500	↑	40	40	16	25	0.030103			
12	630	↑	40	40	16	25	↓	NOT APPLICABLE	0.053013	0.034859
13	800		40	40	16	25				
14	1000	↑	40	40	16	25	↓	NOT APPLICABLE	0.053013	0.034859
15	1250		38	38	15	23				
16	1600	↑	34	34	12	21	↓	NOT APPLICABLE	0.053013	0.040221
17	2000		32	32	9	18				
18	2500	↑	30	30	5	15	↓	NOT APPLICABLE	0.047712	0.034859
19	3150		29	29	4	14				
20	4000	↑	29	29	5	14	↓	NOT APPLICABLE	0.053013	0.034859
21	5000		30	30	6	15				
22	6300	∞	31	31	10	17	0.029960	<u>0.029960</u>	0.068160	0.037349
23	8000	44.3	37	34	17	23	0.042285	↓	0.079520	"
24	10000	50.7	41	37	21	29	"		"	0.059640

BAND (i)	ISO BAND	f Hz	SPL(a)	SPL(b)	SPL(c)	SPL(d)	SPL(e)	$M(b)$	$M(c)$	$M(d)$	$M(e)$
1	17	50	91.0	64	52	49	55	0.043478	0.030103	0.079520	0.058098
2	18	63	85.9	60	51	44	51	0.040570	0.030103	0.068160	0.058098
3	19	80	87.3	56	49	39	46	0.036831	0.030103	0.068160	0.052288
4	20	100	79.0	53	47	34	42	0.036831	0.030103	0.059640	0.047534
5	21	125	79.8	51	46	30	39	0.035336	0.030103	0.053013	0.043573
6	22	160	76.0	48	45	27	36	0.033333	0.030103	0.053013	0.043573
7	23	200	74.0	46	43	24	33	0.033333	0.030103	0.053013	0.040221
8	24	250	74.9	44	42	21	30	0.032051	0.030103	0.053013	0.037349
9	25	315	94.6	42	41	18	27	0.030675	0.030103	0.053013	0.034859
10	26	400	∞	40	40	16	25	0.030103	↑ NOT APPLICABLE ↓	0.053013	0.034859
11	27	500	∞	40	40	16	25	0.030103		0.053013	0.034859
12	28	630	∞	40	40	16	25	0.030103		0.053013	0.034859
13	29	800	∞	40	40	16	25	0.030103		0.053013	0.034859
14	30	1 000	∞	40	40	16	25	0.030103		0.053013	0.034859
15	31	1 250	∞	38	38	15	23	0.030103		0.059640	0.034859
16	32	1 600	∞	34	34	12	21	0.029960		0.053013	0.040221
17	33	2 000	∞	32	32	9	18	0.029960		0.053013	0.037349
18	34	2 500	∞	30	30	5	15	0.029960		0.047712	0.034859
19	35	3 150	∞	29	29	4	14	0.029960		0.047712	0.034859
20	36	4 000	∞	29	29	5	14	0.029960	0.053013	0.034859	
21	37	5 000	∞	30	30	6	15	0.029960	0.053013	0.034859	
22	38	6 300	∞	31	31	10	17	0.029960	0.029960	0.068160	0.037349
23	39	8 000	44.3	37	34	17	23	0.042285	0.029960	0.079520	0.037349
24	40	10 000	50.7	41	37	21	29	0.042285	0.029960	0.059640	0.043573

Figure A2-3. Example of perceived noise level corrected for tones as a function of aeroplane flyover time Perceived noisiness as a function of sound pressure level

6. NOMENCLATURE: SYMBOLS AND UNITS RESERVED

<i>Symbol</i>	<i>Unit</i>	<i>Meaning</i>
antilog	—	<i>Antilogarithm to the base 10.</i>
$C(k)$	dB	<i>Tone correction factor.</i> The factor to be added to PNL(k) to account for the presence of spectral irregularities such as tones at the k -th increment of time.
d	s	<i>Duration time.</i> The length of the significant noise time history being the time interval between the limits of $t(1)$ and $t(2)$ to the nearest 0.5 second.
D	dB	<i>Duration correction.</i> The factor to be added to PNLTm to account for the duration of the noise.
EPNL	EPNdB	<i>Effective perceived noise level.</i> The value of PNL adjusted for both the spectral irregularities and the duration of the noise. (The unit EPNdB is used instead of the unit dB.)
$f(i)$	Hz	<i>Frequency.</i> The geometrical mean frequency for the i -th one-third octave band.
$F(i,k)$	dB	<i>Delta-dB.</i> The difference between the original sound pressure level and the final broadband sound pressure level in the i -th one-third octave band at the k -th interval of time.
h	dB	<i>dB down.</i> The level to be subtracted from PNLTm that defines the duration of the noise.
H	%	<i>Relative humidity.</i> The ambient atmospheric relative humidity.
i	—	<i>Frequency band index.</i> The numerical indicator that denotes any one of the 24 one-third octave bands with geometrical mean frequencies from 50 to 10 000 Hz.
k	—	<i>Time increment index.</i> The numerical indicator that denotes the number of equal time increments that have elapsed from a reference zero.
log	—	<i>Logarithm to the base 10.</i>
$\log n(a)$	—	<i>Noise discontinuity coordinate.</i> The $\log n$ value of the intersection point of the straight lines representing the variation of SPL with $\log n$.
$M(b), M(c)$, etc.	—	<i>Noise inverse slope.</i> The reciprocals of the slopes of straight lines representing the variation of SPL with $\log n$.
n	noy	<i>Perceived noisiness.</i> The perceived noisiness at any instant of time that occurs in a specified frequency range.
$n(i,k)$	noy	<i>Perceived noisiness.</i> The perceived noisiness at the k -th instant of time that occurs in the i -th one-third octave band.
$n(k)$	noy	<i>Maximum perceived noisiness.</i> The maximum value of all of the 24 values of $n(i)$ that occurs at the k -th instant of time.

<i>Symbol</i>	<i>Unit</i>	<i>Meaning</i>
$N(k)$	noy	<i>Total perceived noisiness.</i> The total perceived noisiness at the k th instant of time calculated from the 24 instantaneous values of $n(i,k)$.
$p(b), p(c)$, etc.	—	<i>Noy slope.</i> The slopes of straight lines representing the variation of SPL with $\log n$.
PNL	PNdB	<i>Perceived noise level.</i> The perceived noise level at any instant of time. (The unit PNdB is used instead of the unit dB.)
PNL(k)	PNdB	<i>Perceived noise level.</i> The perceived noise level calculated from the 24 values of SPL(i,k) at the k th increment of time. (The unit PNdB is used instead of the unit dB.)
PNLM	PNdB	<i>Maximum perceived noise level.</i> The maximum value of PNL(k). (The unit PNdB is used instead of the unit dB.)
PNLT	TPNdB	<i>Tone corrected perceived noise level.</i> The value of PNL adjusted for the spectral irregularities that occur at any instant of time. (The unit TPNdB is used instead of the unit dB.)
PNLT(k)	TPNdB	<i>Tone corrected perceived noise level.</i> The value of PNL(k) adjusted for the spectral irregularities that occur at the k th increment of time. (The unit TPNdB is used instead of the unit dB.)
PNLTM	TPNdB	<i>Maximum tone corrected perceived noise level.</i> The maximum value of PNLT(k). (The unit TPNdB is used instead of the unit dB.)
PNLT _r	TPNdB	<i>Tone corrected perceived noise level adjusted for reference conditions.</i>
$s(i,k)$	dB	<i>Slope of sound pressure level.</i> The change in level between adjacent one-third octave band sound pressure levels at the i th band for the k th instant of time.
$\Delta s(i,k)$	dB	<i>Change in slope of sound pressure level.</i>
$s'(i,k)$	dB	<i>Adjusted slope of sound pressure level.</i> The change in level between adjacent adjusted one-third octave band sound pressure levels at the i th band for the k th instant of time.
$\bar{s}(i,k)$	dB	<i>Average slope of sound pressure level.</i>
SPL	dB re 20 μ Pa	<i>Sound pressure level.</i> The sound pressure level at any instant of time that occurs in a specified frequency range.
SPL(a)	dB re 20 μ Pa	<i>Noy discontinuity coordinate.</i> The SPL value of the intersection point of the straight lines representing the variation of SPL with $\log n$.
SPL(b) SPL(c)	dB re 20 μ Pa	<i>Noy intercept.</i> The intercepts on the SPL axis of the straight lines representing the variation of SPL with $\log n$.

<i>Symbol</i>	<i>Unit</i>	<i>Meaning</i>
$SPL(i,k)$	dB re 20 μ Pa	<i>Sound pressure level.</i> The sound pressure level at the k -th instant of time that occurs in the i -th one-third octave band.
$SPL'(i,k)$	dB re 20 μ Pa	<i>Adjusted sound pressure level.</i> The first approximation to broadband sound pressure level in the i-th one-third octave band for the k-th instant of time.
$SPL(i)$	dB re 20 μ Pa	<i>Maximum sound pressure level.</i> The sound pressure level that occurs in the i-th one-third octave band of the spectrum for PNLTM.
$SPL(i)_r$	dB re 20 μ Pa	<i>Corrected maximum sound pressure level.</i> The sound pressure level that occurs in the i-th one-third octave band of the spectrum for PNLTM corrected for atmospheric sound absorption.
$SPL''(i,k)$	dB re 20 μ Pa	<i>Final broadband sound pressure level.</i> The second and final approximation to broadband sound pressure level in the i-th one-third octave band for the k-th instant of time.
t	s	<i>Elapsed time.</i> The length of time measured from a reference zero.
t_1, t_2	s	<i>Time limit.</i> The beginning and end, respectively, of the significant noise time history defined by h.
Δt	s	<i>Time increment.</i> The equal increments of time for which PNL(k) and PNLT(k) are calculated.
T	s	<i>Normalizing time constant.</i> The length of time used as a reference in the integration method for computing duration corrections, where $T=10$ s.
$t(^{\circ}\text{C})$	$^{\circ}\text{C}$	<i>Temperature.</i> The ambient atmospheric temperature.
$\alpha(i)$	dB/100 m	<i>Test atmospheric absorption.</i> The atmospheric attenuation of sound that occurs in the i-th one-third octave band for the measured atmospheric temperature and relative humidity.
$\alpha(i)_o$	dB/100 m	<i>Reference atmospheric absorption.</i> The atmospheric attenuation of sound that occurs in the i-th one-third octave band for a reference atmospheric temperature and relative humidity.
A_1	degrees	<i>First constant* climb angle.</i>
A_2	degrees	<i>Second constant** climb angle.</i>
δ	degrees	<i>Thrust cutback angles.</i> The angles defining the points on the take-off flight path at which thrust reduction is started and ended, respectively.
ϵ	degrees	
η	degrees	<i>Approach angle.</i>
η_r	degrees	<i>Reference approach angle.</i>

<i>Symbol</i>	<i>Unit</i>	<i>Meaning</i>
θ	degrees	<i>Noise angle (relative to flight path).</i> The angle between the flight path and noise path. It is identical for both measured and corrected flight paths.
ψ	degrees	<i>Noise angle (relative to ground).</i> The angle between the noise paths and the ground. It is identified for both measured and corrected flight paths.
μ	degrees	<i>Engine noise emission parameter.</i> (See 9.3.4.)
Δ_1	EPNdB	<i>PNLT correction.</i> The correction to be added to the EPNL calculated from measured data to account for noise level changes due to differences in atmospheric absorption and noise path length between reference and test conditions.
Δ_2	EPNdB	<i>Adjustment to duration correction.</i> The adjustment to be made to the EPNL calculated from measured data to account for noise level changes due to the noise duration between reference and test conditions.
Δ_3	EPNdB	<i>Source noise adjustment.</i> The adjustment to be made to the EPNL calculated from measured data to account for noise level changes due to differences between reference and test engine regime.

...

* Gear up, speed of at least $V_2 + 19$ km/h ($V_2 + 10$ kt), take-off thrust.

** Gear up, speed of at least $V_2 + 19$ km/h ($V_2 + 10$ kt), after cutback.

...

7. SOUND ATTENUATION IN AIR

...

7.2 The relationship between sound attenuation, frequency, temperature and humidity is expressed by the following equations:

$$\alpha(i) = 10^{[2.05 \log(f_0/1000) + 1.1394 \times 10^{-3} \times T - 1.916984]} + \eta(\delta) \times 10^{[\log(f_0) + 8.42994 \times 10^{-3} \times T - 2.755624]}$$

$$\delta = \sqrt{\frac{1010}{f_0}} 10^{(\log \#RH - 1.328924 + 3.179768 \times 10^{-2} \times T)} \times 10^{(-2.173716 \times 10^{-4} \times T^2 + 1.7496 \times 10^{-6} \times T^3)}$$

where:

$\eta(\delta)$ is given by Table A2-4 and f_0 by Table A2-5;

$\alpha(i)$ being the attenuation coefficient in dB/100 m;

T being the temperature in °C; and

$\#RH$ being the relative humidity expressed as a percentage.

7.3 The equations given in 7.2 are convenient for calculation by means of a computer.

...

8. ADJUSTMENT OF AIRCRAFT FLIGHT TEST RESULTS

8.1 Flight profiles and noise geometry

Flight profiles for both test and reference conditions are described by their geometry relative to the ground, the associated aircraft ground speed, and, in the case of aeroplanes, the associated engine-control noise performance parameter(s) used for determining the acoustic emission of the aeroplane. Idealized aircraft flight profiles are described in 8.1.1 for aeroplanes and 8.1.2 for helicopters.

...

8.1.2 Helicopter flight profiles

8.1.2.1 Reference take-off profile characteristics

Figure A2-7 illustrates the profile characteristics for the helicopter take-off procedure for noise measurements made at the take-off noise measurement point:

- a) the helicopter is initially stabilized in level flight at point A at the best rate of climb speed V_y . The helicopter continues to point B where take-off power is applied, and a steady climb is initiated. A steady climb is maintained through point X and beyond to point F, the end of the noise flight path; and

...

8.1.3 Adjustment of measured noise levels from measured to reference profile in the calculation of EPNL

Note.— The “useful portion of the measured flight path” referred to in this section is defined in accordance with the requirements of 2.3.2.

8.1.3.1 For the case of a microphone located beneath the flight path, the portions of the test flight path and the reference flight path which are significant for the adjustment of the measured noise levels from the measured profile to the reference profile in the EPNL calculation are illustrated in Figure A2-10, where:

- a) XY represents the useful portion of the measured flight path (Figure A2-10 a)), and $X_r Y_r$ that of the corresponding reference flight path (Figure A2-10 b)); and
- b) K is the actual noise measurement point and K_r the reference noise measurement point. Q represents the aircraft position on the measured flight path at which the noise was emitted and observed as PNLTM at point K. The angle between QK and the direction of flight along the measured flight path is θ , the acoustic sound emission angle. Q_r is the corresponding position on the reference flight path where the angle between $Q_r K_r$ is also θ . QK and $Q_r K_r$ are, respectively, the measured and reference noise sound propagation paths.

...

8.1.3.2 For the case of a microphone laterally displaced to the side of the flight path, the portions of the test flight path and the reference flight path which are significant for the adjustment of the measured noise levels from the measured profile to the reference profile in the EPNL calculation are illustrated in Figure A2-11, where:

- a) XY represents the useful portion of the measured flight path (Figure A2-11 a)), and $X_r Y_r$ that of the corresponding reference flight path (Figure A2-11 b)); and
- b) K is the actual noise measurement point and K_r the reference noise measurement point. Q represents the aircraft position on the measured flight path at which the noise was emitted and observed as PNLTM at point K. The angle between QK and the direction of flight along the measured flight path is θ , the acoustic sound emission angle. The angle between QK and the ground is ψ , the elevation angle. Q_r is the corresponding position on the reference flight path where the angle between $Q_r K_r$ and the direction of flight along the reference flight path is also θ , and the angle between $Q_r K_r$ and the ground is ψ_r , where in the case of aeroplanes, the difference between ψ and ψ_r is minimized.

...

8.1.3.3 In both situations the acoustic sound emission angle θ shall be established using three-dimensional geometry.

8.1.3.4 In the case of lateral full-power noise measurements of jet aeroplanes the extent to which differences between ψ and ψ_r can be minimized is dependent on the geometrical restrictions imposed by the need to maintain the reference microphone on a line parallel to the extended runway centre line.

Note.— In the case of helicopter measurements, there is no requirement to minimize the difference between ψ and ψ_r .

...

8.2 Selection of adjustment method

...

8.2.3 For aeroplanes, either the simplified method, described in 8.3, or the integrated method, described in 8.4, shall be used for the lateral, flyover or approach conditions. The integrated method shall be used when:

- a) for flyover, the absolute value of the difference between the value of $EPNL_r$ $EPNL_R$, when calculated according to the simplified method described in 8.3, and the measured value of EPNL calculated according to the procedure described in 4.1.3 is greater than 8 EPNdB;
- b) for approach, the absolute value of the difference between the value of $EPNL_r$ $EPNL_R$, when calculated according to the simplified method described in 8.3, and the measured value of EPNL calculated according to the procedure described in 4.1.3 is greater than 4 EPNdB; or
- c) for flyover or approach, the value of $EPNL_r$ $EPNL_R$, when calculated according to the simplified method described in 8.3, is greater than the maximum noise levels prescribed in 3.4 of Part II, Chapter 3, less 1 EPNdB.

Note.— Part II, Chapter 3, 3.7.6, specifies limitations regarding the validity of test data based upon both the extent to which $EPNL_r$ $EPNL_R$ differs from $EPNL$ $EPNL$, and also the proximity of the final

$EPNL_r$, $EPNL_R$ values to the maximum permitted noise levels, regardless of the method used for adjustment.

8.3 Simplified method of adjustment

8.3.1 General

8.3.1.1 The simplified adjustment method consists of the determination and application of adjustments to the EPNL calculated from the measured data for the differences between measured and reference conditions at the moment of PNLTM. The adjustment terms are:

- a) Δ_1 — adjustment for differences in the PNLTM spectrum under test and reference conditions (see 8.3.2);
- b) $\Delta_{peak} - \Delta_{peak}$ — adjustment for when the PNLT for a secondary peak, identified in the calculation of EPNL from measured data and adjusted to reference conditions, is greater than the PNLT for the adjusted PNLTM spectrum (see 8.3.3);

...

8.3.1.2 The coordinates (time, X, Y and Z) of the reference data point associated with the emission of PNLTM, $PNLTM_R$ shall be determined such that the acoustic sound emission angle θ on the reference flight path, relative to the reference microphone, is the same value as the acoustic sound emission angle of the as-measured data point associated with PNLTM.

8.3.1.3 The adjustment terms described in 8.3.2 to 8.3.5 are applied to the EPNL calculated from measured data to obtain the simplified reference condition effective perceived noise level, $EPNL_r$, $EPNL_R$ as described in 8.3.6.

...

8.3.2 Adjustments to spectrum at PNLTM

8.3.2.1 The one-third octave band levels $SPL(i)$ used to construct $PNL(k_M)$ (the PNL at the moment of PNLTM observed at measurement point K) shall be adjusted to reference levels $SPL_r(i)$ as follows:

$$\begin{aligned}
 SPL_r(i) &= SPL(i) + 0.01 [\alpha(i) - \alpha(i)_0] QK \\
 &+ 0.01 \alpha(i)_0 (QK - Q_r K_r) \\
 &+ 20 \log (QK / Q_r K_r) \\
 SPL_R(i) &= SPL(i) + 0.01 [\alpha(i) - \alpha_R(i)] QK \\
 &+ 0.01 \alpha_R(i) (QK - Q_r K_r) \\
 &+ 20 \log (QK / Q_r K_r)
 \end{aligned}$$

In this expression:

- the term $0.01 [\alpha(i) - \alpha(i)_0] QK$ accounts for the effect of the change in sound attenuation due to atmospheric absorption, and $\alpha(i)$ and $\alpha(i)_0$ are the coefficients for the test and reference atmospheric conditions, respectively, obtained from Section 7;
- the term $0.01 \alpha_R(i) (QK - Q_r K_r)$ accounts for the effect of the change in the noise sound

propagation path length on the sound attenuation due to atmospheric absorption;

- the term $20 \log (QK/Q_r K_r)$ accounts for the effect of the change in the noise sound propagation path length due to spherical spreading (also known as the “inverse square” law);
- QK and $Q_r K_r$ are measured in metres, and $\alpha(i)$ and $\alpha_r(i)$ are obtained in the form of dB/100 m.

Note.— Refer to Figures A2-10 and A2-11 for identification of positions and distances referred to in this paragraph.

8.3.2.2 The adjusted values of $SPL_r(i)$ obtained in 8.3.2.1 shall be used to calculate a reference condition PNLT value, $PNLT_R(k_M)$, as described in 4.2 and 4.3 of this appendix. The value of the bandsharing adjustment, Δ_B , calculated for the test-day PNLTM by the method of 4.4.2, shall be added to this $PNLT_R(k_M)$ value to obtain the reference condition $PNLTM_R$:

$$PNLTM_R = PNLTM + \Delta_B$$

An adjustment term, Δ_1 , is then calculated as follows:

$$\Delta_1 = PNLTM - PNLTM_R$$

8.3.2.3 Δ_1 shall be added algebraically to the EPNL calculated from measured data as described in 8.3.6.

8.3.3 Adjustment for secondary peaks

8.3.3.1 During a test flight any values of PNLT that are within 2 dB of PNLTM are defined as “secondary peaks”. The one-third octave band levels for each “secondary peak” shall be adjusted to reference conditions according to the procedure defined in 8.3.2.1. Adjusted values of $PNLT_R$ shall be calculated for each “secondary peak” as described in 4.2 and 4.3 of this appendix. If any adjusted peak value of $PNLT_R$ exceeds the value of $PNLTM_R$, a Δ_{peak} adjustment shall be applied.

8.3.3.2 Δ_{peak} shall be calculated as follows:

$$\Delta_{peak} = PNLTM - PNLTM_R$$

where $PNLT_R(k_{M2})$ is the reference condition PNLT value of the largest of the secondary peaks; and $PNLTM_R$ is the reference condition PNLT value at the moment of PNLTM.

8.3.3.3 Δ_{peak} shall be added algebraically to the EPNL calculated from measured data as described in 8.3.6.

8.3.4 Adjustment for effects on noise duration

...

8.3.4.2 Referring to the flight paths shown in Figures A2-10 and A2-11, the adjustment term Δ_2 shall be calculated from the measured data as follows:

$$\Delta_2 = -7.5 \log (QK/Q_r K_r) + 10 \log (V_G/V_{G_r} V_{GR})$$

where:

V_G is the test ground speed (horizontal component of the test airspeed); and

$V_{G_r} V_{GR}$ is the reference ground speed (horizontal component of the reference airspeed).

...

8.3.5 Source noise adjustments

8.3.5.1 The source noise adjustment shall be applied to take account of differences in test and reference source noise generating mechanisms. For this purpose the effect on aircraft propulsion source noise of differences between the acoustically significant propulsion operating parameters actually realized in the certification flight tests and those calculated or specified for the reference conditions of Chapter 3, 3.6.1.5, is determined. Such operating parameters may include for jet aeroplanes, the engine-control noise performance parameter μ (typically normalized low pressure fan speed, normalized engine thrust or engine pressure ratio), for propeller-driven aeroplanes both shaft horsepower and propeller helical tip Mach number and for helicopters, during overflight only, advancing rotor blade tip Mach number. The adjustment shall be determined from manufacturer's data approved by the certificating authority.

8.3.5.2 For aeroplanes, the adjustment term Δ_3 shall normally be determined from sensitivity curve(s) of EPNL versus the propulsion operating parameter(s) referred to in 8.3.5.1. It is obtained by subtracting the EPNL value corresponding to the measured value of the correlating parameter from the EPNL value corresponding to the reference value of the correlating parameter. The adjustment term Δ_3 shall be added algebraically to the EPNL value calculated from the measured data (see 8.3.6).

Note.— Representative data for jet aeroplanes are illustrated in Figure A2-12 which shows a curve of EPNL versus the engine-control noise performance parameter μ . The EPNL data is adjusted to all other relevant reference conditions (airplane mass, speed, height and air temperature) and, at each value of μ , for the difference in noise between the installed engine and the flight manual standard of engine.

...

8.3.5.5 For helicopter overflight, if any combination of the following three factors results in the measured value of an agreed noise correlating parameter deviating from the reference value of this parameter, then source noise adjustments shall be determined from manufacturer's data approved by the certificating authority:

- a) airspeed deviations from reference;
- b) rotor speed deviations from reference; and/or
- c) temperature deviations from reference.

This adjustment should normally be made using a sensitivity curve of $PNLTM_r$ versus advancing blade tip Mach number. The adjustment may be made using an alternative parameter, or parameters, approved by the certificating authority.

Note 1.— If it is not possible during noise measurement tests to attain the reference value of advancing blade tip Mach number or the agreed reference noise correlating parameter, then an extrapolation of the sensitivity curve is permitted, provided the data cover an adequate range of values, agreed by the certificating authority, of the noise correlating parameter. The advancing blade tip Mach

number, or agreed noise correlating parameter, shall be computed from as measured data. Separate curves of PNLTM_F , PNLTM_R versus advancing blade tip Mach number, or another agreed noise correlating parameter, shall be derived for each of the three certification microphone locations, centre line, left sideline and right sideline, defined relative to the direction of flight of each test run.

...

8.3.6 Application of adjustment terms for simplified method

Determine EPNL for reference conditions, EPNL_F , EPNL_R , using the simplified method, by adding the adjustment terms identified in 8.3.2 through 8.3.5 to the EPNL calculated for measurement conditions as follows:

$$\text{EPNL}_F, \text{EPNL}_R = \text{EPNL} + \Delta_1 + \Delta_{\text{Peak}} + \Delta_2 + \Delta_3$$

...

8.4 Integrated method of adjustment

8.4.1 General

8.4.1.1 The integrated method consists of recomputing, under reference conditions, points in the PNL time history corresponding to measured points obtained during the tests, and then computing EPNL directly for the new time history.

8.4.1.2 The emission coordinates (time, X, Y, and Z) of the reference data point associated with each $\text{PNLT}_F(k)$ shall be determined such that the acoustic sound emission angle θ on the reference flight path, relative to the reference microphone, is the same value as the acoustic sound emission angle of the as-measured data point associated with $\text{PNLT}(k)$.

Note.— As a consequence, and unless the test and reference conditions are identical, the reception time intervals between the reference data points will typically neither be equally-spaced nor equal to one-half second.

8.4.1.3 The steps in the integrated procedure are as follows:

- a) The spectrum associated with each test-day data point, $\text{PNLT}(k)$, is adjusted for spherical spreading and attenuation due to atmospheric absorption, to reference conditions (see 8.4.2.1);
- b) A reference tone-corrected perceived noise level, $\text{PNLT}_F(k)$, $\text{PNLT}_R(k)$, is calculated for each one-third octave band spectrum (see 8.4.2.2);
- c) The maximum value, PNLTM_F , PNLTM_R and first and last 10 dB-down points are determined from the PNLT_F , PNLT_R series (see 8.4.2.3 and 8.4.3.1);
- d) The effective duration, $\delta t_F(k)$, $\delta t_R(k)$, is calculated for each $\text{PNLT}_F(k)$, $\text{PNLT}_R(k)$ point, and the reference noise duration is then determined (see 8.4.3.2 and 8.4.3.3);
- e) The integrated reference condition effective perceived noise level, EPNL_F , EPNL_R , is determined by the logarithmic summation of $\text{PNLT}_F(k)$, $\text{PNLT}_R(k)$ levels within the noise duration normalized to a duration of 10 seconds (see 8.4.4); and
- f) A source noise adjustment is determined and applied (see 8.4.5).

8.4.2 PNLT computations

8.4.2.1 The measured values of $SPL(i,k)$ shall be adjusted to the reference values $SPL_r(i,k)$ for the differences between measured and reference sound propagation path lengths and between measured and reference atmospheric conditions, by the methods of 8.3.2.1. Corresponding values of $PNL_r(k)$ shall be computed as described in 4.2.

8.4.2.2 For each value of $PNL_r(k)$, a tone correction factor $C(k)$ shall be determined by analysing each reference value $SPL_r(i,k)$ by the methods of 4.3, and added to $PNL_r(k)$ to obtain $PNLT_r(k)$.

8.4.2.3 The maximum reference condition tone corrected perceived noise level, $PNLTM_r$, shall be identified, and a new reference condition bandsharing adjustment, Δ_{BR} , shall be determined and applied as described in 4.4.2.

Note.— Due to differences between test and reference conditions, it is possible that the maximum $PNLT_R$ value will not occur at the data point associated with $PNLTM$. The determination of $PNLTM_r$ is independent of $PNLTM$.

8.4.3 Noise duration

8.4.3.1 The limits of the noise duration shall be defined as the 10 dB-down points obtained from the series of reference condition $PNLT_r(k)$ values. Identification of the 10 dB-down points shall be performed in accordance with 4.5.1. In the case of the integrated method, the first and last 10 dB-down points shall be designated as k_{FR} and k_{LR} .

8.4.3.2 The noise duration for the integrated reference condition shall be equal to the sum of the effective durations, $\delta t_r(k)$, associated with each of the $PNLT_r(k)$ data points within the 10 dB-down period, inclusive.

8.4.3.3 The effective duration, $\delta t_r(k)$, shall be determined for each $PNLT_r(k)$ reference condition data point as follows:

$$\delta t_r(k) = [(t_r(k) - t_r(k-1)) + (t_r(k+1) - t_r(k))] / 2$$

where:

$t_r(k)$ is the time associated with $PNLT_r(k)$;

$t_r(k-1)$ is the time associated with $PNLT_r(k-1)$, the data point preceding $PNLT_r(k)$; and

$t_r(k+1)$ is the time associated with $PNLT_r(k+1)$, the data point following $PNLT_r(k)$.

Note 1.— Due to differences in flight path geometry, airspeed and sound speed between test and reference conditions, the times, $t_r(k)$, associated with the $PNLT_r(k)$ points projected to the reference flight path are likely to occur at varying, non-uniform time intervals.

Note 2.— Relative values of time $t_r(k)$ for the reference data points can be determined by using the distance between such points on the reference flight path, and the reference aircraft airspeed V_r .

Note 3.— The Environmental Technical Manual (Doc 9501), Volume I — Procedures for the Noise Certification of Aircraft, provides additional guidance for one method for performing the integrated procedure, including the determination of effective durations, $\delta t_f(k)$ $\delta t_R(k)$, for the individual data points of the reference time history.

8.4.4 Calculation of integrated reference condition EPNL

8.4.4.1 The equation for calculating reference condition EPNL using the integrated method, $EPNL_{L_R}$, $EPNL_R$, is similar to the equation for test-day EPNL given in 4.6. However, the numerical constant related to one-half second intervals is eliminated, and a multiplier is introduced within the logarithm to account for the effective duration of each $PNLT_f(k)$ $PNLT_R(k)$ value, $\delta t_f(k)$ $\delta t_R(k)$:

$$EPNL_f = 10 \log \frac{1}{T_U} \sum_{k_{FR}}^{k_{LF}} 10^{0.1 PNL_{T_f}(k)} \delta t_f(k)$$

$$EPNL_R = 10 \log \frac{1}{t_0} \sum_{k_{FR}}^{k_{LR}} 10^{0.1 PNL_{T_R}(k)} \delta t_R(k)$$

where:

the reference time, T_0 t_0 , is 10 seconds;

k_{FR} k_{LR} and k_{FR} k_{LR} are the first and last 10 dB-down points as defined in 8.4.3.1; and

$\delta t_f(k)$ $\delta t_R(k)$ is the effective duration as defined in 8.4.3.3 of each reference condition $PNLT_f(k)$ $PNLT_R(k)$ value.

8.4.5 Source noise adjustment

8.4.5.1 Finally, a source noise adjustment shall be determined by the methods of 8.3.5, and added to the $EPNL_f$ $EPNL_R$ determined in 8.4.4.1.

...

APPENDIX 3. EVALUATION METHOD FOR NOISE CERTIFICATION OF PROPELLER-DRIVEN AEROPLANES NOT EXCEEDING 8 618 kg — Application for Type Certificate submitted before 17 November 1988

...

4.2.2 Correction of noise received on the ground

The noise measurements made at heights different from 300 m (985984 ft) shall be adjusted to 300 m (985984 ft) by the inverse square law.

4.2.3 Performance correction

...

4.2.3.2 The performance correction shall be calculated by using the following formula:

$$\Delta dB = 49.6 - 20 \log \left[(3500 - D_{15}) \frac{R/C}{V_y} + 15 \right]$$

$$\Delta dB = 49.6 - 20 \log \left[(3500 - D_{15}) \frac{\text{Best R/C}}{V_Y} + 15 \right]$$

where D_{15} = Take-off distance to 15 m at maximum certificated take-off mass and maximum take-off power (paved runway)

Best R/C = Best rate of climb at maximum certificated take-off mass and maximum take-off power

V_y = Climb speed corresponding to R/C at maximum take-off power and expressed in the same units.

...

**APPENDIX 4. EVALUATION METHOD FOR NOISE CERTIFICATION
OF HELICOPTERS NOT EXCEEDING 3 175 kg MAXIMUM
CERTIFICATED TAKE-OFF MASS**

...

2.3 Flight path measurement

2.3.1 The helicopter spatial position relative to the flight path reference point measurement microphone shall be determined by a method which is approved by the certifying authority and is independent of normal cockpit flight instrumentation, such as radar tracking, theodolite triangulation or photographic scaling techniques, approved by the certifying authority.

Note.— Guidance material on aircraft position measurement systems is provided in the Environmental Technical Manual (Doc 9501), Volume I — Procedures for the Noise Certification of Aircraft.

...

2.4 Flight test conditions

2.4.1 The helicopter shall be flown in a stabilized flight condition over a distance sufficient to ensure that the time-varying sound level is measured during the entire time period that the sound level is within 10 dB(A) of L_{Amax} L_{ASmax} .

Note.— L_{Amax} L_{ASmax} is defined as the maximum of the A-frequency-weighted S-time-weighted sound level measured during the test run.

2.4.2 The helicopter flyover noise test shall be conducted at the airspeed referred to in Part II, Chapter 11, 11.5.2, with such airspeed adjusted as necessary to produce the same advancing blade tip Mach number as associated with the reference conditions.

2.4.3 The reference advancing blade tip Mach number (M_R), M_{ATR} , is defined as the ratio of the arithmetic sum of the blade tip rotational speed (V_T), V_{tipR} , and the reference helicopter true airspeed V_T , V_R , divided by the speed of sound (c_R), c_R , at 25°C such that:

$$M_R = \frac{(V_T + V_R)}{c_R}$$

$$M_{ATR} = \frac{(V_{tipR} + V_R)}{c_R}$$

3. NOISE UNIT DEFINITION

3.1 The sound exposure level, L_{AE} , is defined as the level, in decibels, of the time integral of squared A-weighted sound pressure (P_A), p_A , over a given time period or event, with reference to the square of the standard reference sound pressure (P_0), p_0 , of 20 μ Pa and a reference duration of one second.

3.2 This unit is defined by the expression:

$$L_{AE} = 10 \log \frac{1}{T_0} \int_{t_1}^{t_2} \left(\frac{P_A(t)}{P_0} \right)^2 dt$$

$$L_{AE} = 10 \log \frac{1}{t_0} \int_{t_1}^{t_2} \left(\frac{P_A(t)}{P_0} \right)^2 dt$$

where T_0 is the reference integration time of one second and $(t_2 - t_1)$ is the integration time interval.

3.3 The above integral can be approximated from periodically sampled measurement as:

$$L_{AE} = 10 \log \frac{1}{T_0} \sum_{k_F}^{k_L} 10^{0.1 L_{AS}(k)} \Delta t$$

$$L_{AE} = 10 \log \frac{1}{t_0} \sum_{k_F}^{k_L} 10^{0.1 L_{AS}(k)} \Delta t$$

where $L_{AS}(k)$ is the time varying A-frequency-weighted S-time-weighted sound level measured at the k -th instant of time, k_F and k_L are the first and last increment of k , and Δt is the time increment between samples.

...

4.4 Noise measurement procedures

...

4.4.4 The A-frequency-weighted sound level of the background noise, including ambient noise and electrical noise of the measurement systems, shall be determined in the test area with the system gain set at levels which will be used for helicopter noise measurements. If the L_{Amax} of each test run does not exceed the A-frequency-weighted sound level of the background noise by at least 15 dB(A), flyovers at an approved lower height may be used and the results adjusted to the reference measurement height by an approved method.

...

5.2 Corrections and adjustments

...

5.2.2 The adjustments for spherical spreading and duration may be approximated from:

$$\Delta_1 = 12.5 \log (H/150) \text{ dB}$$

where H is the height, in metres, of the test helicopter when directly over the noise measurement point.

5.2.3 The adjustment for the difference between reference airspeed and adjusted reference airspeed is calculated from:

$$\Delta_z = -10 \log \left(\frac{V_{af}}{V_f} \right) \text{ dB}$$

$$\Delta_2 = 10 \log \left(\frac{V_{AR}}{V_R} \right)$$

where Δ_2 is the quantity in decibels that must be algebraically added to the measured SEL noise level to correct for the influence of the adjustment of the reference airspeed on the duration of the measured flyover event as perceived at the noise measurement station. V_f is the reference airspeed as prescribed under Part II, Chapter 11, 11.5.2, and V_{AR} is the adjusted reference airspeed as prescribed in 2.4.2 of this appendix.

...

6.3 Validity of results

...

Note.— *Methods for calculating the 90 per cent confidence interval are given in the section of the Environmental Technical Manual (Doc 9501), Volume I — Procedures for the Noise Certification of Aircraft concerning the calculation of confidence intervals.*

...

APPENDIX 5. MONITORING AIRCRAFT NOISE ON AND IN THE VICINITY OF AERODROMES

...

1. INTRODUCTION

...

Note 3.— *This appendix specifies the measuring equipment to be used in order to measure noise levels created by aircraft in the operation of an aerodrome. The noise levels measured according to this appendix are approximations to perceived noise levels ~~PNL~~ PNL, in PNdB, as calculated by the method described in Appendix I, 4.2.*

...

**APPENDIX 6. EVALUATION METHOD FOR NOISE
CERTIFICATION OF PROPELLER-DRIVEN AEROPLANES
NOT EXCEEDING 8 618 kg — Application for Type Certificate
or Certification of Derived Version submitted
on or after 17 November 1988**

...

2.3 Aeroplane testing procedures

2.3.1 The test procedures and noise measurement procedure shall be acceptable to the airworthiness and noise certifying authorities of the State issuing the certification approved by the certifying authority.

2.3.2 The flight test programme shall be initiated at the maximum take-off mass for the aeroplane, and the mass shall be adjusted to maximum take-off mass after each hour of flight time.

2.3.3 The flight test shall be conducted at $V_Y \pm 9$ km/h ($V_Y \pm 5$ kt) indicated airspeed.

2.3.4 The aeroplane spatial position relative to the flight path reference point measurement microphone shall be determined by a method approved by the certifying authority and is independent of normal cockpit flight instrumentation, such as radar tracking, theodolite triangulation or photographic scaling techniques, approved by the certifying authority.

Note.— Guidance material on aircraft position measurement systems is provided in the Environmental Technical Manual (Doc 9501), Volume I — Procedures for the Noise Certification of Aircraft.

2.3.5 The aeroplane height when directly over the microphone shall be measured by an approved technique. The aeroplane shall pass over the microphone within $\pm 10^\circ$ from the vertical and within ± 20 per cent of the reference height (see Figure A6-1).

...

3. NOISE UNIT DEFINITION

The L_{Amax} L_{ASmax} is defined as the maximum level, in decibels, of the A-weighted sound pressure (slow response) with reference to the square of the standard reference sound pressure (P_0), p_0 , of 20 micropascals (μ Pa).

...

5.2 Corrections and adjustments

5.2.1 The adjustments take account of the effects of:

- a) differences in atmospheric absorption between meteorological test conditions and reference conditions;
- b) differences in the noise sound propagation path length between the actual aeroplane flight path and the reference flight path;
- c) the change in the helical tip Mach number between test and reference conditions; and

d) the change in engine power between test and reference conditions.

5.2.2 The noise level under reference conditions $(L_{Amax})_{REF}, L_{ASmaxR}$, is obtained by adding increments for each of the above effects to the test day noise level $(L_{Amax})_{TEST}, L_{ASmax}$.

$$(L_{Amax})_{REF} - L_{ASmaxR} = (L_{Amax})_{TEST} - L_{ASmax} + \Delta_1 + \Delta_2 + \Delta_3 + \Delta_4$$

where

~~$\Delta(M)$ is the adjustment for the change in atmospheric absorption between test and reference conditions;~~

Δ_1 is the adjustment for noise sound propagation path lengths;

Δ_2 is the adjustment for helical tip Mach number; and

Δ_3 is the adjustment for engine power; and

Δ_4 is the adjustment for the change in atmospheric absorption between test and reference conditions;

a) When the test conditions are within those specified in Figure A6-2, no adjustments for differences in atmospheric absorption need be applied, i.e. ~~$\Delta(M)$~~ $\Delta_4 = 0$. If conditions are outside those specified in Figure A6-2 then adjustments must be applied by an approved procedure or by adding an increment ~~$\Delta(M)$~~ Δ_4 to the test day noise levels where:

$$\begin{aligned} \Delta(M) &= 0.01 (H_T \alpha - 0.2 H_R) \\ \Delta_4 &= 0.01 (H \times \alpha_{500} - 0.2 H_R) \end{aligned}$$

and where ~~H_T~~ H is the height in metres of the test aeroplane when directly over the noise measurement point, H_R is the reference height of the aeroplane above the noise measurement point, and α_{500} is the rate of absorption at 500 Hz specified in Tables A1-5 to A1-16 of Appendix 1.

b) Measured noise levels should be adjusted to the height of the aeroplane over the noise measuring point on a reference day by algebraically adding an increment equal to Δ_1 . When test day conditions are within those specified in Figure A6-2:

$$\begin{aligned} \Delta_1 &= 22 \log (H_T/H_R) \\ \Delta_1 &= 22 \log (H/H_R) \end{aligned}$$

When test day conditions are outside those specified in Figure A6-2:

$$\begin{aligned} \Delta_1 &= 20 \log (H_T/H_R) \\ \Delta_1 &= 20 \log (H/H_R) \end{aligned}$$

where ~~H_T~~ H is the height of the aeroplane when directly over the noise measurement point, and H_R is the reference height of the aeroplane over the measurement point.

c) No adjustments for helical tip Mach number variations need be made if the propeller helical tip Mach number is:

...

$$\Delta_2 = K_2 \log (M_T/M_H)$$

$$\Delta_2 = k_2 \log (M_{HR}/M_H)$$

which shall be added algebraically to the measured noise level, where M_T , M_H and M_R , M_{HR} are the test and reference helical tip Mach numbers respectively. The value of K_2 , k_2 shall be determined from approved data from the test aeroplane. In the absence of flight test data and at the discretion of the certifying authority a value of K_2 , $k_2 = 150$ may be used for M_T , M_H less than M_R , M_{HR} ; however, for M_T , M_H greater than or equal to M_R , M_{HR} no correction is applied.

Note.— The reference helical tip Mach number M_R , M_{HR} is the one corresponding to the reference conditions above the measurement point:

where

$$M_T = \frac{\left[\left(\frac{D\pi N}{60} \right)^2 + V_T^2 \right]^{1/2}}{e}$$

$$M_R = \frac{\left[\left(\frac{D\pi N}{60} \right)^2 + V_R^2 \right]^{1/2}}{c_{HR}}$$

where D is the propeller diameter in metres.

V_T , V_R is the true airspeed of the aeroplane in reference conditions in metres per second.

N is the propeller speed in reference conditions in rpm. If N is not available, its value can be taken as the average of the propeller speeds over nominally identical power conditions during the flight tests.

e , c_{HR} is the reference day speed of sound at the altitude of the aeroplane in metres per second based on the temperature at the reference height assuming an ISA temperature lapse rate with height defined by the ICAO Standard Atmosphere (i.e. 0.65°C per 100 m).

- d) Measured sound levels shall be adjusted for engine power by algebraically adding an increment equal to:

$$\Delta_3 = K_3 \log (P_T/P_0)$$

$$\Delta_3 = k_3 \log (P_0/P)$$

where P_T , P and P_R , P_0 are the test and reference engine powers respectively obtained from the manifold pressure/torque gauges and engine rpm. The value of K_3 , k_3 shall be determined from approved data from the test aeroplane. In the absence of flight test data and at the discretion of the certifying authority a value of K_3 , $k_3 = 17$ may be used. The reference power P_R , P_0 shall be that obtained at the reference height—pressure and temperature and pressure—assuming an ISA temperature lapse rate with height assuming temperature and pressure lapse rates with height defined by the ICAO Standard Atmosphere.

Note 1.— Details for calculating the variation of reference atmospheric temperature and pressure with altitude are given in the section of the Environmental Technical Manual (Doc 9501), Volume I—Procedures for the Noise Certification of Aircraft, concerning the ICAO Standard Atmosphere.

Note 2. —The characteristics of the ICAO Standard Atmosphere are specified in the Manual of the ICAO Standard Atmosphere (Doc 7488/3).

6.2 Validity of results

6.2.1 The measuring point shall be overflowed at least six times. The test results shall produce an average noise level (L_{Amax}) value, L_{ASmax} , and its 90 per cent confidence limits, the noise level being the arithmetic average of the corrected acoustical measurements for all valid test runs over the measuring point.

ATTACHMENT D. GUIDELINES FOR EVALUATING AN ALTERNATIVE METHOD OF MEASURING HELICOPTER NOISE DURING APPROACH

2.3 Approach reference procedure

The approach reference procedure shall be established as follows:

- a) the helicopter shall be stabilized and following approach paths of 3°, 6° and 9°;
- b) the approach shall be made at a stabilized airspeed equal to the best rate of climb speed, V_y , V_Y , or the lowest approved speed for the approach, whichever is the greater, with power stabilized during the approach and over the flight path reference point, and continued to a normal touchdown;

ATTACHMENT F. GUIDELINES FOR NOISE CERTIFICATION OF TILT-ROTORS

Note.— See Part II, Chapter 13.

Note 1.— ~~These guidelines are applicable to heavier than air aircraft that can be supported in flight chiefly by the reactions of the air on two or more power driven rotors on axes which can be changed from substantially vertical to horizontal.~~

Note 2.— These guidelines are not intended to be used for tilt-rotors that have one or more configurations that are certificated for airworthiness for STOL only. In such cases, different or additional guidelines would likely be needed.

...

2. NOISE EVALUATION MEASURE

The noise evaluation measure should be the effective perceived noise level in EPNdB as described in Appendix 2 of this Annex.

Note.— Additional data in SEL and L_{Amax} L_{ASmax} as defined in Appendix 4, and one-third octave SPLs as defined in Appendix 2 corresponding to L_{Amax} L_{ASmax} should be made available to the certifying authority for land-use planning purposes.

...

3. NOISE MEASUREMENT REFERENCE POINTS

A tilt-rotor, when tested in accordance with the reference procedures of Section 6 and the test procedures of Section 7, should not exceed the noise levels specified in Section 4 at the following reference points:

...

c) *Approach reference noise measurement points:*

- 1) a flight path reference point located on the ground 120 m (394 ft) vertically below the flight path defined in the approach reference procedure (see 6.4). On level ground, this corresponds to a position 1 140 m from the intersection of the 6.0° ~~degree~~ approach path with the ground plane;

...

4. MAXIMUM NOISE LEVELS

For tilt-rotors specified in Section 1, the maximum noise levels, when determined in accordance with the noise evaluation method of Appendix 2 for helicopters, should not exceed the following:

- a) ~~At the take-off flight path reference point~~ *For take-off:* 109 EPNdB for tilt-rotors in VTOL/conversion mode with maximum certificated take-off mass, at which the noise certification is requested, of 80 000 kg and over and decreasing linearly with the logarithm of the tilt-rotor mass at a rate of 3 EPNdB per halving of mass down to 89 EPNdB after which the limit

is constant.

- b) ~~At the overflight path reference point~~For overflight: 108 EPNdB for tilt-rotors in VTOL/conversion mode with maximum certificated take-off mass, at which the noise certification is requested, of 80 000 kg and over and decreasing linearly with the logarithm of the tilt-rotor mass at a rate of 3 EPNdB per halving of mass down to 88 EPNdB after which the limit is constant.

Note 1.— For the tilt-rotor in aeroplane mode, there is no maximum noise level.

Note 2.— VTOL/conversion mode is all approved configurations and flight modes where the design operating rotor speed is that used for hover operations.

- c) ~~At the approach flight path reference point~~For approach: 110 EPNdB for tilt-rotors in VTOL/conversion mode with maximum certificated take-off mass, at which the noise certification is requested, of 80 000 kg and over and decreasing linearly with the logarithm of the tilt-rotor mass at a rate of 3 EPNdB per halving of mass down to 90 EPNdB after which the limit is constant.

Note.— The equations for the calculation of noise levels as a function of take-off mass presented in Section 7 of Attachment A, for conditions described in Chapter 8, 8.4.1, are consistent with the maximum noise levels defined in these guidelines.

...

6.1 General conditions

...

6.1.5 The reference procedures should be ~~established for~~ calculated under the following reference atmospheric conditions:

- a) ~~sea level constant~~ atmospheric pressure of 1 013.25 hPa;
- b) ~~constant~~ ambient air temperature of 25°C, i.e. ~~ISA + 10 C~~;
- c) ~~constant~~ relative humidity of 70 per cent; and
- d) zero wind.

...

6.3 Overflight reference procedure

6.3.1 The overflight reference procedure should be established as follows:

- a) the tilt-rotor should be stabilized in level flight overhead the flight path reference point at a height of 150 m (492 ft);
- b) a constant configuration selected by the applicant should be maintained throughout the overflight reference procedures;
- c) the mass of the tilt-rotor should be the maximum take-off mass at which noise certification is requested;

- d) in the VTOL/conversion mode, the nacelle angle at the authorized fixed operation point that is closest to the lowest nacelle angle certificated for zero airspeed, a speed of $0.9 V_{CON}$ and a rotor speed stabilized at the maximum normal operating rpm certificated for level flight should be maintained throughout the overflight reference procedure;

Note.— For noise certification purposes, V_{CON} is defined as the maximum authorized speed for VTOL/conversion mode at a specific nacelle angle.

- e) in the aeroplane mode, the nacelles should be maintained on the down-stop throughout the overflight reference procedure, with:
- 1) rotor speed stabilized at the rpm associated with the VTOL/conversion mode and a speed of $0.9 V_{CON}$; and
 - 2) rotor speed stabilized at the normal cruise rpm associated with the aeroplane mode and at the corresponding $0.9 V_{MCP}$ or $0.9 V_{MO}$, whichever is lesser, certificated for level flight.

Note 1.— For noise certification purposes, V_{MCP} is defined as the maximum operating limit airspeed for aeroplane mode corresponding to minimum engine installed, maximum continuous power (MCP) available for sea level pressure (1 013.25 hPa), 25°C ambient conditions at the relevant maximum certificated mass; and V_{MO} is the maximum operating (MO) limit airspeed that may not be deliberately exceeded.

6.3.2 *Note 2.—*The values of V_{CON} and V_{MCP} or V_{MO} used for noise certification should be quoted in the approved flight manual.

6.4 Approach reference procedure

The approach reference procedure should be established as follows:

- a) the tilt-rotor should be stabilized and follow a 6.0° degree approach path;

...

7. TEST PROCEDURES

...

7.4 Adjustments for differences between test and reference flight procedures should not exceed:

- a) *for take-off:* 4.0 EPNdB, of which the arithmetic sum of $-\Delta_1$ and the term $-7.5 \log(QK/Q_r)$ from $-\Delta_2$ should not in total exceed 2.0 EPNdB; and

...

7.5 During the test the average rotor rpm should not vary from the normal maximum operating rpm by more than ± 1.0 per cent during throughout the 10 dB-down time period.

7.6 The tilt-rotor airspeed should not vary from the reference airspeed appropriate to the flight demonstration by more than ± 9 km/h (± 5 kt) throughout the 10 dB-down time period.

7.7 The number of level overflights made with a headwind component should be equal to the number of level overflights made with a tailwind component.

7.8 The tilt-rotor should fly within $\pm 10^\circ$ degrees or ± 20 m (± 65 ft), whichever is greater, from the vertical above the reference track throughout the 10 dB-down time period (see Figure 8-1 of Part II, Chapter 8).

7.9 The tilt-rotor height should not vary during overflight from the reference height ~~at the overhead point~~ throughout the 10 dB-down period by more than ± 9 m (30 ft).

7.10 During the approach noise demonstration the tilt-rotor should be established on a stabilized constant speed approach within the airspace contained between approach angles of 5.5° degrees and 6.5° degrees throughout the 10 dB-down period.

...

**ATTACHMENT H. GUIDELINES FOR OBTAINING HELICOPTER
NOISE DATA FOR LAND-USE PLANNING PURPOSES**

...

2. DATA COLLECTION PROCEDURES

2.1 Data suitable for land-use planning purposes may be derived directly from Chapter 8 noise certification data. Chapter 8 applicants may optionally elect to acquire data suitable for land-use planning purposes via alternative take-off, approach and/or flyover procedures defined by the applicant and approved by the certifying authority. Alternative flyover procedures should be performed overhead the flight path reference point at a height of 150 m (492 ft). In addition, an applicant may optionally elect to provide data at additional microphone locations.

2.2 Chapter 11 noise certification data may be provided for land-use planning purposes. Chapter 11 applicants may optionally elect to provide data acquired via alternative flyover procedures at 150 m (492 ft) above ground level. In acquiring data for land-use planning purposes, Chapter 11 applicants should give consideration to acquiring data from two additional microphones symmetrically disposed at 150 m on each side of the flight path and/or additional take-off and approach procedures defined by the applicant and approved by the certifying authority. In addition, an applicant may optionally elect to provide data at additional microphone locations.

...

3. REPORTING OF DATA

...

3.2 It is recommended that all data provided for land-use planning purposes be presented in terms of average sound exposure level (L_{AE} , L_{AE}) as defined in Appendix 4 of this volume, for left sideline, centre line and right sideline measurement points defined relative to the direction of flight for each test pass run. Additional data in other noise metrics may also be provided and should be derived in a manner that is consistent with the prescribed noise certification analysis procedure.

...

Agenda Item 7: Environmental guidance for airports and operations**7.1 STATUS OF WG2 ACTIVITIES**

7.1.1 The co-Rapporteurs of WG2 presented an overview of the group's activities during CAEP/10.

7.1.2 WG2 created a website on operational interdependencies with noise and emissions that includes an annotated bibliography of ICAO documents with relevant information. A new Circular with case studies on Community Engagement for Aviation Environmental Management was also prepared. Case studies that illustrate the application of ICAO Doc 10031, *Guidance on Environmental Assessment of Proposed Air Traffic Management Operational Changes*, were collected. A detailed Aviation System Block Upgrades (ASBU) Block 0 fuel burn and CO₂ emissions analysis, along with a proposal for conducting a similar analysis for ASBU Block 1, were completed. The *Airport Planning Manual*, Part 2 has been updated to include three new chapters, including one on Infrastructure for Environmental Management and the *Airport Air Quality Manual* (ICAO Doc 9889) was updated. In addition, *ad hoc* support to the ICAO Air Navigation Bureau was included in the WG2 tasks.

Discussions and conclusions

7.1.3 Several members and observers commended WG2 for providing guidance on how to best strike a balance between environmental protection, economic development and social progress in the aviation sector. They explained that their priorities for future work include noise-related community engagement, a manual on operational opportunities to reduce aircraft noise, more in-depth work related to climate adaptation, and for a robust analysis of ASBU Block 1 environmental benefits. They also saw value in the development of a glossary of environmental terms and suggested that the Secretariat carry out this work.

7.1.4 Another member outlined her priorities for the CAEP/11 work programme of WG2. She noted that not all tasks are time critical, and the noise manual and Static ATM tasks should be deferred, and she explained that her priorities include an ASBU Block 1 environmental benefits analysis, further disaggregation of the benefits from individual operational changes in order to improve the trends assessment, and a synthesis of existing information on the range of projected climate impacts for the aviation sector. She recommended that a more robust update to ICAO Doc 9889, *Airport Air Quality Manual*, be led by WG3 in collaboration with WG2.

7.1.5 The meeting expressed their support for the work carried out by WG2, highlighting that its deliverables provide support to all States in the form of guidance for improving environmental assessment and the environmental management of airport and aviation operations.

7.1.6 The Secretariat described how WG2 is different from WG1 and WG3, as it does not produce aeroplane standards. WG2 provides guidance to States, especially where airports are being developed and built. This guidance is an opportunity to secure a high level of environmental integrity in aircraft and airport operations, from the airport design phase onwards. Therefore, it is essential to respond to the request for more guidance made by States. Specifically for the next CAEP cycle, the Secretariat has received requests for guidance on climate change adaptation and aircraft recycling.

7.1.7 The WG2 co-Rapporteurs explained that WG2 would be in the position to build on CAEP/10 activities related to climate change adaptation in order to advance a more comprehensive task on this subject during CAEP/11. The participation of aircraft manufacturers in WG2 activities, as well as

the nomination of relevant experts by States would be necessary in order to take on work related to aircraft dismantling and recycling.

7.1.8 The meeting noted the priorities regarding CAEP/11 tasks for WG2 and agreed to discuss them during future work.

7.2 OPERATIONAL INTERDEPENDENCIES

7.2.1 WG2 initiated work during CAEP/9 with the goal to provide a single access point for information on environmental interdependencies contained in ICAO documents. A new webpage listing the 16 ICAO documents with this information in the form of an annotated bibliography was prepared and made available on the ICAO public website (<http://www.icao.int/environmental-protection/Pages/CAEP-Operational-InterdependencyTask.aspx>). In addition, the website offers the ability to search the documents.

Discussion and Conclusions

7.2.2 The meeting congratulated WG2 for the quality and thoroughness of the work delivered, and approved the expanded website and the status report. The meeting agreed to discuss the continuation of this work to include an assessment of existing information related to interrelationships under future work.

7.3 AIRPORT COMMUNITY ENGAGEMENT

7.3.1 WG2 prepared a new circular on Airport Community Engagement based on the information contained in 48 case studies which were collected from all regions. This broad range of information allowed a series of lessons learned to be included as part of the circular.

Discussion and Conclusions

7.3.2 The meeting recognized the importance of this work, with a member highlighting that community acceptance of local aviation activities is essential. Should community engagement not be addressed, obstacles to accommodate the predicted growth in demand would be difficult to overcome.

7.3.3 A member was of the view that PBN is important but new noise is not well received. She supported a future task undertaken with caution, as some States were addressing legal issues, and stressed the need to well scope any task with this concern in mind. A member offered resources in support to the task and in so making, confirmed that these concerns were taken into account.

7.3.4 An observer noted that the circular includes some discussion on best practices regarding community engagement on the implementation of performance based navigation (PBN) procedures, but suggested that additional work regarding this area was needed. The Secretariat invited the relevant stakeholders to share their specific experiences with PBN implementation and community engagement. The meeting agreed to discuss this further under future work, recognizing the significant benefits offered by PBN and the potential local sensitivities associated with its implementation.

7.3.5 The meeting agreed that the title of the circular be changed to “Community Engagement for Aviation Environmental Management”, in order to reflect better the scope of the information that it contains.

7.3.6 Recommendation

7.3.6.1 In light of the foregoing discussion, the meeting developed the following recommendation:

Recommendation 7/1 — Publication of a Circular on Community Engagement for Aviation Environmental Management

The Circular “Community Engagement for Aviation Environmental Management” be published in all languages, and made available free of charge on the ICAO public website.

7.4 BEST PRACTICE ENVIRONMENTAL ASSESSMENT

7.4.1 WG2 collected 10 case studies from States, illustrating how the environmental assessment carried out during air traffic management operational changes was aligned with ICAO Document 10031 “Guidance on Environmental Assessment of Proposed Air Traffic Management Operational Changes”. The quantification of the environmental impacts in the context of the environmental assessment was coordinated with the ASBU analysis and the operational interdependencies task.

Discussion and Conclusions

7.4.2 The meeting considered this work to be complete, agreed to post the analysis on the website, and agreed to discuss the continued collection of case studies to inform the development of a future edition of Doc 10031 under future work.

7.5 UPDATE TO THE *AIRPORT PLANNING MANUAL*, PART 2 (ICAO DOC 9184)

7.5.1 WG2 updated the *Airport Planning Manual*, Part 2 to include elements on eco-friendly airport planning and best practices in land-use planning and management. An additional task to undertake a full review of Part 2 was added at the 2013 CAEP Steering Group meeting for delivery during CAEP/11.

7.5.2 This update added three new chapters: Chapter 4 on “Infrastructure for Environmental Management,” Chapter 8 on “Heritage Management,” and Chapter 9 on “Climate Change Resilience and Adaptation,” as well as three new Appendices, which were proposed for completion during the CAEP/11 work programme: Appendix 1 “Case Studies of Airport Infrastructure For Environmental Management,” Appendix 4 “Heritage Considerations,” and Appendix 5 “Climate Change Resilience.”

7.5.3 In addition to the new chapters, the manual was updated to include revisions throughout the document and in particular to Appendix 2 “Cases of Effective Land Use Management Around Airports” and Appendix 3 “Fact Sheets on land-use planning measures related to airports, as practised in various countries.”

Discussion

7.5.4 The meeting congratulated WG2 for the completion of this task, noting that WG2 delivered more than had been originally planned for the CAEP/10 cycle. The meeting found the result of this task to be of significant benefit to States and for this reason, urged that the Council consider making it available free-of-charge on the ICAO website.

7.5.5 An observer highlighted the importance of future work related to climate change adaptation and resilience, in particular for those States in vulnerable areas. The meeting agreed that this would be discussed under future work.

7.5.6 An observer suggested that the *Airport Planning Manual*, Part 1 may also need to be updated as a result of this work.

7.5.7 The meeting recommended changing the name of the *Airport Planning Manual*, Part 2 – *Land Use and Environmental Control*, to “*Airport Planning Manual*, Part 2 – *Land Use and Environmental Management*.”

7.5.8 Recommendation

7.5.8.1 In light of the foregoing discussion, the meeting developed the following recommendation:

Recommendation 7/2 — Airport Planning Manual, Part 2

The updated APM Part 2 be published and that case studies be collected and made available on the ICAO website.

7.6 ASBU ENVIRONMENTAL ANALYSIS

7.6.1 In 2013, ICAO initiated the Aviation System Block Upgrade (ASBU) initiative as a programmatic framework that develops a set of Air Traffic Management (ATM) solutions or upgrades, takes advantage of current equipage, establishes a transition plan, and enables global interoperability.

7.6.2 WG2 and MDG were tasked to build upon the preliminary work carried out during CAEP/9 and conduct a high-level estimate, followed by a robust analysis of the potential fuel and CO₂ savings from the implementation of ASBU Block 0. Two additional deliverables were added as a result of decisions by the 2013 ICAO Assembly, and were successfully incorporated into the overall approach. In addition, the groups were asked to scope an approach for a similar analysis of ASBU Block 1.

7.6.3 Compared to the preliminary analysis, additional 4 Block 0 modules were evaluated and 10 new “rules of thumb” were developed to allow the benefits from the implementation of the modules to be evaluated in a consistent manner in all regions. Data to support the analysis was collected from a variety of sources covering 92 per cent of global air traffic movements. The analysis showed that annual CO₂ savings of between 7.8 MT and 15.4 MT or 0.69% to 1.38% could be achieved from the implementation of ASBU Block 0 by 2018 compared to 2013.

Discussion and Conclusions

7.6.4 The meeting congratulated WG2 and MDG on the completion of the analysis and expressed appreciation for the clear manner in which the results were communicated, in particular with how they were put into an appropriate context. The meeting also considered the results of this analysis to be useful in assisting States in communicating the effectiveness of operational changes. The meeting saw value of carrying out a similar analysis for ASBU Block 1.

7.6.5 The Secretariat highlighted the importance of the development of the rules of thumb as part of this work, as it gives States a tool for making their own environmental assessment on operational improvements. The meeting noted that these rules of thumb were included in the ICAO guidance on the development of Action Plans. The meeting noted that the ability to present these results in the context of the CAEP trends assessment will be discussed under future work.

7.6.6 Recommendation

7.6.6.1 In light of the foregoing discussion, the meeting developed the following recommendation:

Recommendation 7/3 — ASBU Environmental Analysis

States be invited to use the ASBU Block 0 environmental analysis by CAEP to support the implementation of ASBU Block 0 and to communicate the environmental benefits from operational improvements within their State.

— — — — —

Agenda Item 8: Alternative fuels**8.1 REPORT OF THE AFTF**

8.1.1 The Co-Rapporteurs of AFTF presented a summary of the group's progress since the establishment of the Task Force in November 2013. Two task groups were formed: the Life Cycle Analysis Task Group and the Fuel Production Assessment Task Group in order to carry out the work.

8.2 ALTERNATIVE FUELS EMISSIONS REPORT (TASKS S.2.1 AND S.2.2)

8.2.1 Substantial work was carried out in the development of a means to account for the life-cycle emissions from the use of alternative jet fuel in the context of the projections to 2050 (see Task S.3.4). The methodology was considered by AFTF to not be suitable for use by States in the preparation of their action plans, instead it was recommended that the LCA for MBM methodology be used once completed.

8.2.2 The methodology developed by AFTF is an attributional life-cycle assessment (LCA), or process-based LCA, meaning that it provides specific emissions indices based on the process and feedstock used to develop the fuel. The result of this work is a table of emission factors that is a synthesis of factors found in the existing literature. Representative LCA values shown in the alternative fuels emissions report do not include emissions from land-use change (LUC). However, LUC emissions are accounted for in the analysis.

8.3 SCOPE OF WORK FOR THE DEVELOPMENT OF SUSTAINABILITY CRITERIA (TASK S.5.1)

8.3.1 AFTF developed a scope of work for establishing recommendations for how sustainability criteria might be defined by taking into account as much as possible existing regulations, schemes and related efforts. It was emphasized that the developed criteria should be able to help define eligibility for recognition of greenhouse gas (GHG) emissions reductions from alternative fuels under a global market-GMBM.

8.4 LIFE-CYCLE ASSESSMENT METHODOLOGY FOR USE IN A GLOBAL MBM MRV SYSTEM (TASK S.4.1)

8.4.1 AFTF developed a methodology to assess life cycle emissions from alternative fuels for use in a global market-based measure (GMBM) monitoring, reporting, and verification (MRV). This methodology is largely based on existing alternative fuel regulations. It includes both the calculation of emissions from land use change as well as a process for assessing the risk of land use change occurring. Specifically, the methodology considers the following aspects:

- a) The alternative fuels accounted for in the GMBM will solely be from biomass and waste derived jet fuels excluding Gas to Liquid (GTL) or Coal to Liquid (CTL);
- b) The LCA methodology will be built on existing LCA frameworks and, where possible, to refer to well-established implementation methodologies;

- c) This methodology can be used to develop a list of default values for lifecycle GHG emissions of alternative jet fuels from alternative feedstock to jet fuel pathways during the CAEP/11 cycle;
- d) Default values for lifecycle GHG emissions will be divided by the lifecycle GHG emissions of the “conventional” jet fuel baseline to obtain the ratio of emissions benefit from the use of a particular alternative fuel compared to conventional jet fuel;
- e) Sample values that test and prove the robustness of the methodology have been provided;
- f) The information regarding the pros and cons of using reduction thresholds to address some alternative fuels that have negative consequences has been assembled;
- g) In order to reach the goal of this methodology, an attributional (process-based) approach is used incorporating, when applicable, the effects from LUC and co-products;
- h) Assessment of life cycle GHG emissions is limited to GHG emissions in supply chain of an aviation fuel from feedstock production to its use in an aircraft;
- i) The methodology includes N₂O and CH₄ expressed in CO₂ equivalent (CO_{2e}), however, it does not include non-CO₂ combustion emissions;
- j) The methodology allocates emissions among co-products based on their energy content;
- k) Emissions from induced LUC are included in the methodology with LUC risk being a key consideration for purposes of classifying feedstocks; and
- l) The life cycle GHG performance of alternative jet fuels needs to be compared against a reference fossil fuel baseline that serves as a benchmark for comparison. The AFTF agreed to use a value of 89 g CO_{2e}/MJ as the fossil fuel baseline for conventional jet fuel.

8.4.2 The AFTF Co-Rapporteurs highlighted that a decision regarding the amortization period to be used for LUC calculations is an essential aspect of this methodology. However, it was not possible to reach consensus on the period to be used within the Task Force. AFTF members generally supported the use of either a 20 year or 30 year amortization period and identified the considerations to taking this policy decision:

20 Year Amortization	30 Year Amortization
Consistent with IPCC and UNFCCC guidelines	Could increase investments into alternative jet fuels
Could benefit better performing alternative fuels (from the standpoint of life cycle GHG emissions)	Consistent with the life of a typical fuel production facility

8.4.3 It was also explained that initial work on the development of safeguards to prevent the use of alternative fuels produced from feedstocks grown in carbon “hot-spots,” in other words, lands with high carbon stocks, has been carried out.

8.5 RANGE OF EMISSIONS FROM ALTERNATIVE JET FUELS TO 2050 (TASKS S.3.1 THROUGH S.3.4)

8.5.1 AFTF carried out an evaluation of the range of potential greenhouse gas (GHG) emissions reductions from the use of alternative fuels in aviation to 2050. This involved the development of projections of potential availability of alternative jet fuels in the short term, to 2020, and in the long term, to 2050. The LCA emission factors were then applied to those fuels in order to assess their potential effect on global emissions.

8.5.2 The short-term scenarios for alternative jet fuels availability were established from announcement by fuel producers regarding their production plans and from the targets set by States in different regions. For the long-term scenarios, AFTF assessed future alternative jet fuel production by estimating the primary bioenergy potential constrained by selected environmental and socio-economic factors; by estimating the proportion of bioenergy potential that could actually be achieved or produced; and by exploring the quantity of alternative jet fuels that could be produced from the available bioenergy. More than 60 different production scenarios were developed.

8.5.3 For 2020, alternative jet fuels production is anticipated to be in the range of 56 kt per year to 6.5 Mt per year, corresponding to near 0 to 2 per cent of global aviation fuel demand in 2020. This results in a reduction of lifecycle GHG emissions of almost 0 to 1.3 per cent compared to petroleum-derived jet fuel.

8.5.4 Future technology improvements were considered in projecting the emissions values to 2050 as were emissions associated with direct LUC. Indirect LUC effects were not considered in the analysis, because the projected production was constrained not to compete against food and feed production.

8.5.5 For 2050, AFTF calculated that depending on the assumptions made in the different scenarios, alternative jet fuel production in 2050 could range from 0 to 4,600 Mt per year. This production range could offset between 0 and 100 per cent of the projected petroleum-derived jet fuel demand in 2050 and could offer a reduction of total lifecycle GHG emissions of between 0 and 63 per cent. The CO₂ emissions trends projection presented in paragraph 1.1 incorporates the results of this analysis.

8.5.6 AFTF indicated that the potential to reduce GHG emissions from aviation by using alternative jet fuels increases with assumptions that imply larger agricultural yield increases; greater land availability; higher accepted rates of residue removal; increases in feedstock and fuel production efficiencies; reductions in GHG emissions from utilities; increased policy emphasis on bioenergy production relative to other land usages in general, and on alternative jet fuels production in particular, among other factors.

Discussion and conclusions

8.5.7 A member expressed her views regarding the work of AFTF. The member agreed with the results of the 2050 fuel production assessment. Regarding AFTF GMBM LCA methodology, the member highlighted that further clarifications to the methodology will be necessary, for example based on the unique features of identified alternative jet fuel pathways and information anticipated to be provided

during the CAEP/11 cycle. Furthermore, the member expressed her support for an amortization period of 30 years, noting that lands being used to produce fuels are typically converted for periods of at least 30 years and biofuel production facilities generally have useful lives of 30 or more years as well. This position was also supported by some members and observers. The member also urged against the inclusion of a GHG emissions reduction threshold for alternative fuels, as that may prevent fuels from receiving any benefit under the GMBM simply on the basis that those fuels do not “do enough” for the environment and their inclusion could increase compliance costs. Some members and observers also supported this view. Several members expressed concern that the use of thresholds would eliminate most of the feedstocks from being used for alternative fuels, while a number of other members and observers did not share this position, arguing that this is an essential element of a GMBM MRV system. A member proposed considering an amortization period of 25 years.

8.5.8 A member stated that “carbon hot-spots” will have to be carefully defined to ensure that they do not prevent the production of fuels that reduce GHG emissions. An observer expressed concerns regarding the definition of “carbon hot-spots” and highlighted the importance of using accurate data and high resolution. This vision was supported by some other members.

8.5.9 Several members and observers expressed their support for the development of context / region-specific default values for GHG emissions reductions as opposed to a set of globally-applicable values. They also urged CAEP to establish a definition of a clearly defined and quantifiable set of sustainability criteria with a view to their inclusion in a GMBM.

8.5.10 A member and some observers explained that new regulatory frameworks and requirements related to the development of alternative jet fuels are expected to be developed worldwide. With a lack of harmonized approaches, a plethora of different regulations and requirements may affect the competitiveness of the industry, and result in economic and administrative burdens vis-à-vis each other for complying with those requirements for similar final purposes. Therefore, they suggested that coordinated approaches are desired for the development of guidance material in this area.

8.5.11 An observer informed the meeting that Oslo Airport has become the world’s first “bioport” with a regular supply of biojet fuel to all airport users. It was explained this was possible due to tremendous cooperation among a broad range of stakeholders.

8.5.12 An observer recommended that the calculation of a more precise LCA value for a given production pathway according to an ICAO-agreed methodology should be available as a substitute for the default value assumed within a GMBM MRV system. In order to be reliable, it was proposed that the data used should be provided directly by producers or suppliers of alternative fuels according to the agreed methodology. The observer also recommended considering further sustainability criteria beyond LCA, and in order to reduce the administrative burden for obtaining recognition for a specific alternative fuel under the GMBM, a framework or “meta-standard” that would define the requirements for existing standards to be acceptable within this context could be used.

8.5.13 An observer recommended that protections against potential conflicts of interest in recognizing alternative fuels that could be considered as eligible for CO₂ emission reductions with the ICAO MBM should be taken. The observer suggested that no person (and no party related to that person) participating in alternative fuels-related MBM governance may have any financial relationship or any direct or indirect business relationship which may reasonably be considered to have some influence on that person’s judgment in their capacity as a participant in the MBM governance process; and further, that for two years following service on the MBM governance body, the person (and any party related to that person) shall refrain from engaging in a financial relationship or direct or indirect business relationship with any aviation fuels provider.

8.5.14 An observer expressed his view that an update to the alternative fuel projections developed by AFTF should account for indirect land use change (iLUC), future sustainability criteria and the impact of the Paris agreement. He, along with 12 members and 2 additional observers also provided their support for the selection of a 20 year amortization period for LUC calculations within a GMBM MRV system, in line with guidance from the IPCC. The observer also recommended that a minimum GHG reduction threshold be instituted as an eligibility criteria for alternative jet fuel within the GMBM to address the uncertainties embedded in the methodology and suggested that further work on a carbon hot-spot safeguard be undertaken by CAEP. The observer encouraged AFTF to develop a set of criteria and procedures to determine when a feedstock could be included in a low-LUC risk list.

8.5.15 An observer informed the meeting of Indonesia's development of an Action Plan as a result of cooperation with ICAO and IATA, as well as their recent cooperation with US FAA to promote the use of sustainable aviation alternative fuels and renewable energy. The meeting noted that DGCA Indonesia anticipates having an Environmental Unit and an MRV regulation operative in 2016.

8.5.16 The meeting thanked AFTF for developing the scope of work for establishing recommendations for how sustainability criteria might be defined. Given the large amount of work already being done regarding sustainability criteria around the world, the meeting agreed that during the discussion on future work consideration of the specific contribution to be made by CAEP in this area is needed. The meeting encouraged efforts to identify appropriate sustainability criteria for alternative fuels, but then recommended that future work on this item proceed with caution to prevent unintended consequences. Furthermore, it was acknowledged that the expertise within CAEP is generally specific to aviation. In shaping that discussion, the meeting recommended that the connection to the global market-based measure (GMBM) be considered, urging that this work should not impede the agreement or implementation of the GMBM. Many members and observers noted that AFTF should reference and use what has already been done with regards to sustainability.

8.5.17 In preparation for a future work discussion related to continued work on the development of an MRV system for use in the GMBM, a number of areas of consideration were identified. These included the desire for a decision on the amortization period to be used for LUC calculations, in order to avoid the duplication of work by AFTF in preparing default values for multiple amortization periods; the need for higher resolution land use data to support the definition of carbon "hot-spots;" whether or not additional work is needed on binning to interpret LCA values; and whether or not AFTF should develop a petition process that is based on submissions from States.

8.5.18 The distinction whether the alternative fuels were used for international aviation compared to use in domestic aviation was highlighted. Whereas the emissions reduction benefit from the use of an alternative fuel could be claimed directly within the GMBM, making it impossible to use that emissions reduction to generate a carbon offset credit, the same would not be true for alternative fuel used in domestic aviation whose emissions were not part of the market-based measure.

8.5.19 The meeting noted that it was important not to create excessive barriers that would prevent the production of alternative fuels for aviation.

8.5.20 The meeting agreed that the work related to the range of emissions from the use of alternative fuels to 2050 is complete. However, it was highlighted that there is a continued need to collect information on near term production and emissions reduction capability. The Secretariat highlighted that the ICAO Global Framework on Aviation Alternative Fuels (GFAAF) is a resource that can be useful in this regard. The meeting expressed that the role of AFTF to integrate that information in the context of the trends is essential. In addition, the CAEP may wish to include putting the results of the future projections of aviation alternative fuels into context with the Paris Agreement in its future work

considerations. It was clarified that the “illustrative example” presented in paragraph 1.1.4.3 is not related to the Paris Agreement. It was also clarified that the results presented in paragraph 1.1.4.3 reflect the assumptions of the analysis, importantly the assumption regarding the global average maximum potential LCA reduction potential from alternative fuels.

8.5.21 A member recommended that the Secretariat organize a roundtable discussion or workshop that would bring the appropriate experts together to further discuss the scenarios and how to progress the actions therein. The meeting agreed to discuss this under future work.

8.5.22 An observer highlighted the effect of the price of conventional fuel on the market forces that can drive the development of alternative fuels. Future work by AFTF may wish to consider this sensitivity in future presentations of results.

8.5.23 The meeting agreed that the LCA methodology for use in a global MBM MRV system developed by the AFTF Lifecycle Analysis Task Group is reasonable and includes conservative features in its evaluation of the GHG emissions reductions from alternative jet fuels.

8.5.24 The meeting agreed that the life cycle analysis methodology being developed by AFTF to support a GMBM should also be used by States in the development of their Action Plans on Emissions Reduction. It was noted that until this methodology is finalized, however, alternative fuels will continue be treated as having zero net emissions for the purposes of the Action Plans.

8.5.25 The meeting agreed to use 89g CO₂e/MJ as the default value for the lifecycle GHG emissions from petroleum-based jet fuel and noted that this translates to approximately 3.67 kg CO₂e per kg of jet fuel, compared to CO₂ from the combustion of jet fuel, which is 3.16 kg CO₂ per kg of jet fuel.

8.5.26 The meeting noted the proposed CAEP activities related to alternative fuels and agreed to discuss them further in the context of future work.

Agenda Item 9: Global market-based measure technical analysis: monitoring, reporting, and verification (MRV) and emissions unit criteria (EUC)

9.1 REPORT OF GMTF

9.1.1 Overviews by the Rapporteurs of GMTF

9.1.1.1 The co-Rapporteurs of the Global Market-Based Measure Technical Task Force (GMTF) presented the developments of its work since the ICAO Council in November 2013 requested CAEP to begin supporting work on the development of a global Market-Based Measure (MBM) scheme. It was highlighted that the GMTF is tasked to provide technical recommendations on the global MBM scheme. Since the establishment of GMTF and its Terms of Reference (TOR) in January 2014, the GMTF held seven face-to-face meetings during the CAEP/10 cycle. To date, GMTF has 167 experts nominated by 20 States and 8 Observer organizations. The GMTF formed sub-groups within its membership on: Monitoring, Reporting and Verification (MRV); Emissions Unit Criteria (EUC); and Analysis Support Group (ASG) which undertook analytical work to support the work of the ICAO Council and its Environment Advisory Group (EAG). In addition, a separate task to make recommendations for Registries was undertaken by GMTF.

9.1.1.2 The meeting was provided with the status of the GMTF work programme under CAEP/10 cycle, indicating that tasks which were still open had been added to the proposed GMTF future work (see Agenda Item 12: Future work) while the GMTF future work might need to be adjusted to the further decision on a global MBM scheme after CAEP/10. To ensure smooth continuation of GMTF work after CAEP/10, it was proposed that already nominated GMTF experts would continue to be considered as the members of the Task Force, unless otherwise advised.

9.1.1.3 The meeting was also provided with a glossary of terms related to MBMs, which was developed by GMTF to have a common understanding of terms when discussing a global MBM scheme.

9.2 MONITORING, REPORTING AND VERIFICATION (MRV)

9.2.1 Scoping Issues under a Global MBM – Accountable Entities and the Definition of International Aviation

9.2.1.1 The GMTF presented the recommendations on identification of an accountable entity and attribution of flights as well as on the definition of “international aviation” for the purposes of a global MBM.

9.2.1.2 The GMTF recommended that the accountable entity in a global MBM (i.e. an entity to account for its emissions and, if relevant, to surrender the appropriate number of emission units) would be the aircraft operator, with a default to the aircraft owner only if the aircraft operator could not be identified. A three tier process was recommended to identify the accountable entity: 1) Tier 1 – ICAO Designator: when Field 7 (aircraft identification) of the flight plan has the ICAO Designator, that flight is attributed to the operator defined in ICAO Document 8585 (Manual on Designators for Aircraft Operating Agencies, Aeronautical Authorities and Services); 2) Tier 2 – Registration Marks: when Field 7 (aircraft identification) of the flight plan corresponds to the registration marks of an aircraft, the owner of the aircraft as identified in the Certificate of Registration is the default accountable entity unless the aircraft operator is alternatively identified through an “accountable entity declaration”; 3) Tier 3 – No ICAO

Designator or Registration Mark: when Field 7 (aircraft identification) of the flight plan is not the ICAO Designator or aircraft registration mark, the owner of the aircraft is the default accountable entity unless the aircraft operator is alternatively identified through an “accountable entity declaration”.

9.2.1.3 The “accountable entity declaration” would provide a means for associating specific aircraft registration marks and/or ICAO Designators with the actual operator and to avoid a “default” to the aircraft owner if the requirements for an accountable entity declaration are met.

9.2.1.4 Regardless of the means used to identify operators, the GMTF recommended that an accountable entity would be able to delegate administrative MRV obligations by contracting to a third party as long as the accountable entity retains ultimate liability for compliance with the MRV requirements and for meeting the emissions offset obligation and the delegation would not be the same entity that will serve as the verifier.

9.2.1.5 The GMTF recommended that aircraft operators in a parent-subsidary relationship would be treated as a single accountable entity. Two or more aircraft operators in a corporate relationship could be a single accountable entity if the entities: 1) bear the same ICAO Designator; and 2) are subject to administration by the same State. GMTF suggested to give additional consideration to the potential pooling of multiple accountable entities into a single accountable entity to reduce costs and administrative burdens.

9.2.1.6 The GMTF recommended the use of the IPCC definitions of “international aviation” for the purposes of the global MBM, as supported by the 2015 Steering Group meeting.

Discussion and Conclusions

9.2.1.7 The meeting approved the GMTF recommendations on the identification of an accountable entity and the definition of “international aviation” for the purposes of the global MBM, as contained in paragraphs 9.2.1.1 to 9.2.1.6 above, as the basis for future CAEP work.

9.2.2 Monitoring of Fuel Use and Emissions for a Global MBM

9.2.2.1 The GMTF presented the recommendations on the monitoring of fuel use and emissions for purposes of a global MBM. The meeting was invited to confirm the previous decision of the 2015 Steering Group meeting (SG) to use a conversion factor of 3.16 g CO₂ per g of Jet-A, and a factor of 3.10 g CO₂ per g of AvGas or Jet-B.

9.2.2.2 The GMTF recommended a combination of a tiered and a menu approach for fuel use monitoring, with methodologies based on actual fuel consumption in Tier 1 and monitoring methodologies based on estimation in Tier 2. It was expected that any methodology in Tier 1 and Tier 2 would be required to meet uncertainty levels defined for each tier. A maximum threshold in terms of level of activity should be considered to define the eligibility of aircraft operators to use methodologies under Tier 2. It was suggested that aircraft operators above this threshold should use monitoring methodologies approved under Tier 1.

9.2.2.3 The GMTF also recommended that emissions monitoring plans should be employed in a global MBM for international aviation, and accountable entities (i.e. aircraft operators) should be required to prepare monitoring plans, including information on: 1) operator/accountable entity identification; 2) fleet and operations data; 3) methods/means of calculating emissions from international flights; and 4) data management, data flow and control.

9.2.2.4 The recommended areas for the procedures on the preparation, submission, review and updates of the emissions monitoring plans included: 1) legal authority/nature of requirement; 2) initial plan preparation and submission; 3) review by State/administering authority; 4) revisions/updates; 5) data flow activities; and 6) use of the monitoring plan by the verifier and State/administering authority.

9.2.2.5 The GMTF recommended that accountable entities should submit the emissions monitoring plans to the State/Administering Authority for review and approval. Accountable entities should keep their plans up to date, and should resubmit their plans to the State/administering authority for re-approval only when there are material changes to the plans affecting the operators' emissions monitoring.

Discussion and Conclusions

9.2.2.6 A member supported the recommendations with regard to a "tiered menu approach" for monitoring, which would provide flexibility to States and operators to utilize existing programs and administrative infrastructure, while still ensuring a robust level of environmental integrity.

9.2.2.7 Clarification was provided on the concept of "material changes", which meant significant changes to the monitoring plan that would require re-approval from the State/administering authority, while the concept intended to avoid unnecessary administrative burden.

9.2.2.8 A member raised a concern about the timeline for developing the monitoring-related provisions due to uncertainty of further discussion by the Council and Assembly. The member also highlighted the importance of ensuring that States have proper expertise to review and approve monitoring plans. It was clarified that the global MBM scheme was evolving and the GMTF was developing recommendations on technical design elements of the global MBM scheme to the Council, and that assistance including the provision of guidance documents for monitoring plans would needed to be sought as part of supporting the implementation of a scheme.

9.2.2.9 The meeting approved the GMTF recommendations related to monitoring of fuel use and emissions for a global MBM, and confirmed previous CAEP decisions on conversion factors, as contained in paragraphs 9.2.2.1 to 9.2.2.5 above, as the basis for further CAEP work.

9.2.3 Reporting of Aviation Emissions

9.2.3.1 The GMTF presented the recommendations on the reporting of CO₂ emissions by aircraft operators as a part of the MRV process, including the recommendations on reporting means and methods, reporting data fields, and transparency and confidentiality in the MRV for a global MBM.

9.2.3.2 The GMTF recommended that a standard online tool with sufficient flexibility for modification to adjust to individual State's needs would be the best method for reporting of operators' emissions. Such a tool would need to contain security rules and should be supported by a secure database for data storage.

9.2.3.3 To ensure the communication between tools used by States and the consistency of reported data, such tools should be interoperable. GMTF recommended to develop a common reporting language to be used for reporting of data from accountable entities to States and from States to ICAO.

9.2.3.4 The GMTF also recommended the use of standardized template to report MRV data by all participants. The reporting template should include fields for reporting of a minimum required data set, with an option to include additional data. The following preliminary "minimum data set" to be reported

by the accountable entities to States was recommended, while this data set should be revised after the other MRV and global MBM design elements are finalized and agreed:

Table 1. Preliminary “minimum data set” to be reported by the accountable entities to States

Accountable entity (aircraft operator) information	Emissions factor(s) used
Reporting year	CO ₂ emissions by country pair or aerodrome pair
Reference details	Total CO ₂ emissions from international aviation
Total number of international flights during reporting period	Explanation for any data gaps
Number of international flights per country pair or aerodrome pair	Inputs necessary to calculate early mover exemption
Aircraft registration numbers	Data necessary to demonstrate alternative fuel use
Fuel(s) used (type, quantity)	

9.2.3.5 A simplified reporting template should be developed to maintain consistency with simplified MRV procedures.

9.2.3.6 Regarding the transparency and access to data and information under the global MBM, the GMTF recommended provisions to be incorporated in the global MBM to ensure compliance with the requirements of the scheme, to maintain a level playing field of the participants and to build the public confidence in a global MBM, while protecting the sensitive information and ensuring the security of participants. The co-Rapporteurs presented data elements that would most likely be reported under the MRV rules and the preliminary recommendations on which stakeholders should have access to the data. It was clarified that the transparency provisions should be developed later in the process, when more information becomes available on the design of the global MBM.

Discussion and Conclusions

9.2.3.7 A member suggested that recommendations on transparency and confidentiality could be further assessed when a global MBM scheme is agreed upon and stakeholders have a better understanding of the information required. It was noted that it is important to find a balance between data transparency and confidentiality. The member also highlighted that it would be important to consider which entity should develop the online reporting tool.

9.2.3.8 A question was raised on the effect of the distribution of offsetting obligations to the data requirements in MRV, and it was clarified that a final decision on technical aspects of MRV could only be determined once a global MBM scheme structure would be agreed.

9.2.3.9 An observer provided information on its national efforts to develop MRV practices and suggested that there would be no duplication of efforts between MRV requirements under a global MBM scheme and the ICAO Form M data reporting.

9.2.3.10 The meeting approved the GMTF recommendations on reporting of aviation emissions, as contained in paragraphs 9.2.3.1 to 9.2.3.6 above, as the basis for further CAEP work.

9.2.3.11 The meeting affirmed that transparency and access to data and information under the global MBM will be needed to ensure compliance with the requirements of the system; to demonstrate the effectiveness of it; ensure equal treatment if its participants; and to achieve public confidence in the global MBM. The confidentiality provisions in the global MBM are necessary to protect data or information that is commercially sensitive and/or raise security concerns for operators.

9.2.4 Verification of Aviation Emissions

9.2.4.1 The co-Rapporteurs of GMTF presented the recommendations on the verification of aviation emissions. Verification of an emissions report was recommended to follow a three stage pathway, starting with a standardized voluntary internal pre-verification by the accountable entity, i.e. aircraft operator (pre-reporting), followed by a mandatory external verification and finalized by a mandatory order of magnitude review by the attributed administering authority (post-reporting).

9.2.4.2 The GMTF also recommended to develop a standardized guidance framework of requirements for carrying out voluntary internal pre-verifications, and to base mandatory external verifications on existing applicable ISO standards (ISO 14064, ISO 14065, and ISO 17011). It was recommended to have a set of requirements for carrying out mandatory post-reporting verifications by administering authorities.

9.2.4.3 The GMTF recommended the development of a database containing global flight traffic data to support external verifiers and enable the administering authorities to verify operators' emissions for flights outside the administering authorities' jurisdiction.

9.2.4.4 The GMTF also recommended an additional process performed independently from the verification process in order to ensure that administering authorities apply a consistent approach to carrying out report verifications and achieve satisfactory levels of independence and self-regulation with the overall aim of an equal treatment of aircraft operators around the world. It was also recommended that ICAO should support the possibility of cooperation between administering authorities as a means of reducing administrative and resource burdens.

Discussion and Conclusions

9.2.4.5 A member highlighted the importance of possible costs for the external verification be available, and the member also asked for support to States for the verification process. It was also noted that performing a pre-verification would most likely reduce the costs for aircraft operators, as they would be better prepared for the external verification.

9.2.4.6 A member asked for clarification regarding to what extent it would be possible to take advantage of existing verification standards, and it was clarified that the global MBM verification process would be based on existing verification systems. The Chairperson encouraged all interested members/observers and their advisors to contribute to further work of the GMTF.

9.2.4.7 The meeting approved the GMTF recommendations on the verification of aviation emissions, as contained in paragraphs 9.2.4.1 to 9.2.4.4 above, as the basis for further CAEP work.

9.2.5 Simplified Procedures and Alternative Fuels

9.2.5.1 The GMTF presented the recommendations on simplified procedures for accountable entities with lower levels of activity and on MRV for alternative fuels claimed under the global MBM.

9.2.5.2 The GMTF recommended that the simplified compliance procedures for accountable entities with lower levels of activity should cover all three elements of monitoring, reporting and verification, rather than just the reporting element, due to the close linkages and interdependencies between the three elements.

9.2.5.3 For the purposes of the global MBM, the GMTF recommended to define “alternative fuels” as being “any fuel that generates lower carbon emissions than conventional kerosene on a life cycle basis”, as agreed by the 2015 Steering Group meeting. The GMTF recommended that the quantity of alternative fuel used would be best tracked by fuel purchased, and that the monitoring of alternative fuels used by actual fuel consumption of individual aircraft operators would not be feasible.

Discussion and Conclusions

9.2.5.4 A member supported the GMTF recommendations and urged that simplified compliance procedures should facilitate the implementation of a global MBM scheme for small operators, without introducing additional complexity. Regarding MRV of alternative fuels, the member emphasized simple rules.

9.2.5.5 A member supported having simplified procedures and asked whether there has been any analysis done on possible eligibility thresholds to use these procedures. It was clarified that analysis on such thresholds would be needed, and GMTF intended to further consider the thresholds.

9.2.5.6 An observer expressed support for the recommendations on simplified procedures and highlighted that the MRV processes need to take into account operators with different levels of activity. Regarding alternative fuels, an observer stated that MRV for alternative fuels should avoid double-counting.

9.2.5.7 The meeting approved the GMTF recommendations on the simplified procedures for accountable entities with lower levels of activity and on MRV for alternative fuels, as contained in paragraphs 9.2.5.1 to 9.2.5.3 above, as the basis for further CAEP work.

9.3 EMISSIONS UNIT CRITERIA (EUC)

9.3.1 Report on EUC

9.3.1.1 The GMTF presented the results of the tasks assigned to the EUC sub-group during the CAEP/10 cycle. The first task required the sub-group to a) review existing criteria for emissions units used in offsetting CO₂ emissions (task 1a), and b) evaluate how, and under what criteria, emissions units from existing or proposed MBMs could be used in a global MBM scheme for international civil aviation (task 1b). The second task required EUC to undertake an assessment of the future availability of emissions units and assess the impact of international civil aviation on the carbon market supply, demand and price (task 2).

9.3.1.2 GMTF recommended that for offset credits, in order to ensure environmental and social integrity, two components need to be evaluated: whether the carbon offset programme meets all specified design elements, and whether and which offset credits produced from the programmes meet specific quality principles.

9.3.1.3 Regarding the programmes that generate offset credits, GMTF recommended that programmes should meet a range of design elements covering the need for: (1) clear, publicly disclosed, methodologies and protocols; (2) considerations of the scope of activities; (3) credit issuance and retirement procedures; (4) identification and tracking of units; (5) the legal nature and transfer of units; (6) validation and verification procedures; (7) governance; (8) transparency and public participation provisions; (9) safeguarding systems to address environmental and social risks; (10) sustainable development criteria; and (11) the avoidance of double counting, issuance and claiming.

9.3.1.4 Regarding offset credits, GMTF recommended that programmes should deliver carbon offset units that represent emissions reductions, avoidance, or sequestration that: (1) are additional; (2) are based on a realistic and credible baseline; (3) are quantified, monitored, reported, and verified; (4) have a clear and transparent chain of custody; (5) represent permanent emissions reductions; (6) assess and mitigate against potential increase in emissions elsewhere; (7) are only counted once towards a mitigation obligation; and (8) do no net harm.

9.3.1.5 While eligibility criteria may be applied at the project type, methodology or project level, it was recommended that determination of eligibility should be made at the programme level as the expertise and resources needed to develop and implement ICAO emissions criteria at a methodology and project level is likely to be considerable.

9.3.1.6 Regarding the allowances from emissions trading programmes, the GMTF recommended that allowances comply with criteria associated with the following points: (1) environmental integrity; (2) the voluntary participation of jurisdictions; (3) market access; (4) double claiming; (5) registry of allowance units; and (6) transparency.

9.3.1.7 The co-Rapporteurs further explained that since the 2015 Steering Group meeting, GMTF also discussed issues and made recommendations related to: EUC governance; early action to purchase emissions units prior to 2020; and vintages, all of which would have an impact on environmental integrity.

9.3.1.8 Regarding the EUC governance, GMTF recommended the formation of a small technical advisory body that makes recommendations to the Council related to the application of the agreed EUC to determine ICAO-eligible emissions unit programmes/project types. In addition, the technical advisory body would, in accordance with established procedures and timetables, review and recommend to the Council revisions of the EUC as needed.

9.3.1.9 Regarding early action by operators to purchase emissions units prior to 2020, GMTF recommended that ICAO encourage such early action in order to foster emissions reductions and to provide some market certainty for the future availability and eligibility of emissions units. To this end, the GMTF recommended that, until the technical advisory body is operational, CAEP constitute a group that would propose a list, in a transparent manner, of programmes/project types that it would recommend meet the GMTF eligibility criteria to be recommended to the Council. Emissions units from programmes/project types included in the list would be eligible for operators' use in meeting compliance obligations post 2020. It was recommended that early action decisions be time bound.

9.3.1.10 Regarding vintages, GMTF recommended that if a decision specifies unit vintage eligibility, it should take as a reference the dates either when the development of the global MBM was decided (year 2013) or when its adoption is foreseen (year 2016).

9.3.1.11 The co-Rapporteurs further presented the work on supply, demand and price of emissions units. GMTF has gathered information on the availability and price of offsets by reviewing existing MBMs. It was explained that there were too many unknown variables to make an accurate quantitative assessment of the carbon markets and their ability to supply demand from international civil aviation beyond 2020. Nevertheless, the project based instruments in use in today's regulated markets, or under discussion, showed the capability to react to demand and provide the necessary supply. This gives confidence that the market will be capable to react on clear signals of future demand from the international aviation global MBM.

9.3.1.12 As supplementary material to the report of EUC, the meeting was provided with a report on the analysis of eligibility criteria used by existing MBMs (task 1a), which reviewed 17 offset crediting programs and 20 allowance-based emissions trading systems to identify the lessons learned and to formulate recommendations for eligibility criteria. The meeting was further provided with a report on recommendations for eligibility criteria for carbon offset programmes, offset credits produced from the programmes, and allowances as summarized above (task 1b). In addition, the meeting was provided with a supporting information report related to the EUC governance, early action, vintages and discounting, as well as a report on supply, demand and price of emissions units (task 2).

Discussion and Conclusions

9.3.1.13 Several members and observers supported the recommendations for emissions unit criteria and the recommendation to apply the criteria at the programme level. A member requested for an open and free market access to allowances to ensure a level-playing field.

9.3.1.14 In addition, several members and observers expressed their support for the early action by operators to purchase emissions units prior to 2020. The meeting noted that early action would be a key element for States and the industry to become familiar with the process, and that further work on this issue and the EUC governance would need to be undertaken. A member expressed that further work should be undertaken as soon as possible to enable early action.

9.3.1.15 A member supported that early action decisions be time bound. It was clarified that the specific period for the validity of emissions units purchased pre-2020 would need further discussion.

9.3.1.16 It was also highlighted that early action would be voluntary for aircraft operators. For the establishment of a technical advisory body, some observers expressed that the Terms of Reference would have to be developed and the membership of the body should avoid conflict of interests.

9.3.1.17 Some members pointed out that emissions unit criteria and the availability of eligible emissions units have implications to States, in particular to the costs for their operators, and that special circumstances of developing countries should be taken into account and support for implementation should be provided. The meeting noted the need to update information on the supply, demand and price of emissions units.

9.3.1.18 An observer expressed the importance of GMTF progress toward the development of a global MBM scheme under ICAO. She also referred to the cooperative approach under the COP21 Paris Agreement and opportunity for ICAO to benefit from guidance, procedures and modalities to be developed under the Paris Agreement in future. She also highlighted the early action in terms of its positive contribution to pre-2020 ambition under the COP21 decision.

9.3.1.19 The meeting approved the GMTF recommendations on eligibility criteria, as contained in paragraphs 9.3.1.1 to 9.3.1.6 above, as the basis for further CAEP work.

9.3.1.20 The meeting also approved the GMTF recommendations on the EUC governance, early action and vintages, as contained in paragraphs 9.3.1.7 to 9.3.1.11 above, as the basis for further CAEP work. The meeting noted that further work is needed regarding recommendations on the EUC governance, early action and vintages.

9.3.1.21 The meeting agreed on the work on supply, demand and price, as described in paragraph 9.3.1.12 above. The meeting noted that further work is needed to update information.

9.4 REGISTRIES

9.4.1 Report on Registries

9.4.1.1 The co-Rapporteurs of GMTF presented the work on registries, and the GMTF recommended that the global MBM registry structure should optimize existing technology and systems where possible, and developing the registry structure that utilizes existing registries and allows the development of new registries would be simpler and more expedient.

9.4.1.2 The GMTF recommended a coordinated registry structure design, where different systems can “talk” with each other and have common 1) technology; 2) rules; and 3) operational processes. This approach would build on the registries that already exist in a number of States and provide States the opportunity to oversee the input of the emissions data and emissions unit purchases to ensure the compliance of their aircraft operators, which it would ensure a role for States and a strong oversight role for ICAO.

Discussion and Conclusions

9.4.1.3 A member welcomed the GMTF work related to registries and suggested that the GMTF in the CAEP/11 cycle should identify early challenges, costs, and decision points for registry development. The member emphasized a simple solution for registries. Some members asked the Secretariat to continue to consult with registry developers and provide relevant information.

9.4.1.4 Several members emphasized the importance of capacity building in order to implement the registry system. It was also noted that those States which already have registry systems in place could provide information to help others to implement registries.

9.4.1.5 A member supported GMTF recommendations for registries, and highlighted that the registry is a key component in ensuring transparency and environmental integrity of a global MBM scheme. The member added that the registry system should be simple and flexible and that experience from existing registries should be utilized to create the registry system.

9.4.1.6 A member recommended having a strong link between registries and the global MBM scheme and that it should be recognized that there are national and regional registries. The member also called for simplicity and highlighted the importance of involving registry specialists into the development process as soon as possible.

9.4.1.7 An observer highlighted the important role registries play for transparency and confidentiality and supported having assistance for States to implement them. The observer added that the registry governance should be free of conflict of interests.

9.4.1.8 The meeting approved the GMTF recommendations on the registry structure, as contained in paragraphs 9.4.1.1 and 9.4.1.2 above, as the basis for further CAEP work.

9.5 GENERAL DISCUSSION AND CONCLUSIONS

9.5.1 A majority of members and observers provided positive feedback on the work undertaken by GMTF during the CAEP/10 cycle and generally supported the recommendations on MRV, EUC and Registries, while also expressing their continuing support for the GMTF’s further work on a number of remaining tasks.

9.5.2 Regarding MRV, several members and observers supported the recommendation for a two-tiered monitoring approach. They supported to also consider monitoring fuel consumption on a flight by flight basis to make a distinction between international and domestic flights. They also supported an uncertainty level no greater than $\pm 2.5\%$ as an appropriate level for Tier 1 monitoring methodologies. They argued that an eligibility threshold for the use of Tier 2 would be needed, which should effectively become an eligibility threshold for the use of simplified procedures.

9.5.3 They underlined that a sufficient level of transparency would be vital for a credible and effective global MBM, while respecting commercial sensibilities at the same time.

9.5.4 They also supported the recommendation that the verification pathway should be comprised of three steps, namely: pre-verification, external third party verification and an order of magnitude check by the administering authority. They considered it important to continue the development of specific recommendations and guidance for each step of the pathway, based on the relevant ISO standards as appropriate. They also encouraged further exploration of potential means for supporting the administering authorities.

9.5.5 They supported the GMTF recommendation that the simplified procedures should cover monitoring, reporting and verification, rather than just reporting. They supported the development of simple and robust procedures for monitoring of alternative fuels used for international flights. The presenters considered that the most appropriate method of tracking alternative fuel used was likely the fuel purchase method.

9.5.6 A member supported the recommendations on data fields and the appropriate means and methods for reporting. The member also supported the effort of identifying data flows to identify who will be reporting what information in a global MBM scheme. In addition, the member supported the recommended verification pathway. The member noted that the work on verification had progressed to a point where CAEP could develop draft guidance to further support the global MBM development. The member also noted that work on alternative fuels was important as these fuels reduce net emissions, and operators could be assured that their investments would yield benefits for purposes of complying with the global MBM scheme.

9.5.7 An observer supported the recommendation for a tiered and menu approach for fuel use and emissions monitoring, and suggested further work to be undertaken on the block hour fuel consumption methodology.

9.5.8 The observer highlighted that the information to be made available should be limited to what is strictly necessary for the administration of a global MBM scheme. The observer was of the view that flight- or aerodrome-pair operator-specific data should not be made available to entities other than the verifier and the State of registration. The observer suggested that only required aggregated data should be made publicly available.

9.5.9 The observer supported the recommendation that the quantity of alternative fuel used would be best tracked by fuel purchase, and suggested that monitoring by actual fuel consumption by individual aircraft operators was not feasible.

9.5.10 An observer expressed that the global MBM governance should provide for the transparent reporting and publication of key data, unless a compelling and well-evidenced case is made for the absolute necessity of confidentiality. The observer highlighted the importance of clearly identifying who would be responsible for collecting and reviewing emissions monitoring plans and emissions reports. The observer also recommended that emissions data should be collected on a flight-by-

flight basis. The observer highlighted that governance with regard to alternative fuels should identify who would be responsible for verifying compliance with sustainability criteria and for verifying that there would be no double-claiming.

9.5.11 Regarding EUC, several members and observers presented their views that criteria should apply primarily at the programme level, but there should also be some flexibility to apply them at a project type level so as to allow as wide a range of units to be available as possible. Regarding the proposed technical advisory body, it was suggested that the upcoming development of the TORs should ensure impartiality and sufficient expertise of its members. Regarding vintages, they proposed the year 2016 to be selected. Regarding early action, it was suggested that the programmes/project types should be selected using a conservative approach and should be reassessed by the technical advisory body, once established. It was suggested that the eligibility of units approved for early action be time bound with the validity of units purchased pre-2020 limited to the first three years of the global MBM's operation. These views were noted by the meeting.

9.5.12 An observer explained its view that robust EUC would obviate the need for any list of specific programmes or projects that might be excluded from being eligible (“negative list”). The meeting noted that work and discussions on this topic would be continued.

9.5.13 An observer expressed its view on the need to develop recommendations on whether, how, and how often the technical advisory body would re-assess programmes; how the body would address indications that an approved programme’s eligibility should be revoked; and by whom and how such decisions are made. The observer proposed that precedents of MBMs which have established governance bodies should be examined. The observer explained that the following key elements should be incorporated into the EUC governance: (1) clear, rigorous procedures for applying EUC; (2) transparency and public participation; and (3) avoiding conflicts of interest. The observer mentioned that the same criteria for overall governance should be applied as rigorously to the early action governance body as to the full technical advisory body. Units approved by the early action body should only be eligible to be used for compliance in the first two years.

9.5.14 A member suggested that conflict of interest rules be based on existing standards and could be included as part of TORs for the early action body and technical advisory body. The meeting noted that additional work would need to be undertaken in the development of these bodies.

9.5.15 Regarding registries, several members and observers highlighted that the global oversight of the registry system is necessary to ensure that a global MBM scheme could function effectively and transparently and that there would be a level playing field for operators. They added that a central registry would be needed to record data on emissions and offset requirements, and to track the compliance of aircraft operators. They also added that for those States or regions that already have functioning registries, the option should be left open for these existing registries to be utilized for the global MBM scheme as well. They also supported the continuation of the work on registries and encouraged the early involvement of registry developers and experts into the process.

9.5.16 An observer highlighted that a registry would be a crucial element of the institutional structure required for the operation of a global MBM, and asked CAEP to confirm that the additional registry work should continue without delay.

9.5.17 An observer proposed convening of an extraordinary session of CAEP, prior to the final Council session before the 2016 Assembly, if required, to approve any additional recommendations. The meeting noted that CAEP might need an expeditious process to inform its further progress to other ICAO bodies, if required.

9.5.18 The meeting agreed that the GMTF had conducted significant work as requested by the Council to date, and approved that this work fulfilled the GMTF TORs and the GMTF work programme for the CAEP/10 cycle.

9.5.19 The meeting agreed to accept the Reports on MRV, EUC and Registries for a global MBM scheme, as submitted to this meeting, be used as the basis of CAEP future work, pending to further decisions on a global MBM scheme by the Council and the Assembly.

9.5.20 The meeting took note that the next GMTF/8 meeting would be held in Montreal in June 2016.

9.5.21 **Recommendation**

9.5.21.1 In light of the foregoing discussion, the meeting developed the following recommendation:

**Recommendation 9/1 — Acceptance of Reports of MRV,
EUC and Registries as the basis of CAEP future work**

That the Reports on MRV, EUC and Registries for a global MBM scheme, as submitted to this meeting, be used as the basis of CAEP future work, pending to further decisions on a global MBM scheme by the Council and the Assembly.

Agenda Item 10: Global market-based measure technical analysis: evaluation of technical proposals**10.1 TECHNICAL ANALYSES ON GLOBAL MBM****10.1.1 Report of the GMTF Analysis Support Group (ASG)**

10.1.1.1 The GMTF presented results of the technical analyses that the GMTF Analysis Support Group (ASG) undertook to support the work of the ICAO Council and its Environment Advisory Group (EAG) in their remit to develop a design for a global Market-based Measure (MBM) for international aviation (refers to paragraph 9.1.1).

10.1.1.2 The meeting was also provided with the supplementary analytical presentations provided to the EAG since July 2015.

10.1.1.3 The technical analyses undertaken were based on the Strawman proposal for a global MBM considered by the EAG, and included: international aviation CO₂ emissions and offsets; the environmental and cost impacts of exemptions; approaches to distribute offset obligations using individual operator's growth rate and/or the sector's growth rate; and adjustments to offsetting obligations for fast growing operators and early movers. Additional approaches analysed included distributing obligations to operators based on historical emissions, and differentiating obligations at the route level.

10.1.1.4 A member presented a view that key criteria and metrics identified to compare the various approaches for distributing offset obligations helped provide an understanding of advantages and disadvantages. The member considered that all requested analyses were completed to date, but encouraged CAEP to be prepared to undertake additional work to support the development of a global MBM scheme if requested in future. The member proposed that GMTF could summarize all analytical work undertaken in a report.

10.1.1.5 An observer recommended to be cautious in dedicating time to undertake additional analyses unless they are specifically requested.

Discussion and Conclusions

10.1.1.6 Several members and observers commended the significant amount of analytical work undertaken by GMTF, which was very helpful to support consideration by the EAG and Council to develop a global MBM scheme for international aviation.

10.1.1.7 The meeting agreed that GMTF ASG has conducted and completed significant analytical work as requested by the EAG and Council to date.

Agenda Item 11: Review of current science related to aircraft noise and emissions**11.1 REPORT OF THE IMPACTS AND SCIENCE GROUP (ISG)**

11.1.1 The Impacts and Science Group (ISG) co-Rapporteurs presented an overview of the activities of the ISG over the CAEP/10 Cycle. During the CAEP/10 cycle, ISG convened an ICAO CAEP Aviation Environmental Impacts Seminar (Alexandria, Virginia, U.S., 10 - 12 February 2015). The aim of the seminar was to obtain input from internationally-recognized experts to inform the process of writing four White Papers. The resulting four white papers provide a general consensus of opinion from the science community on the following topics:

- 1) Aviation and Climate: The paper provided an update to the Aviation and Climate: State of the Science white paper presented to the CAEP/9 meeting. The updated white paper provided a summary of recent progress on the state of the science since 2012, especially related to contrails and induced cloudiness, aerosol and NOx effects, and emissions from alternative aviation fuels.
- 2) Climate Impacts on Aviation: The new white paper summarized the state of knowledge regarding the impacts of climate on aviation operations, from a science perspective. The paper illustrated the importance of multi-disciplinary risk and resilience. It also provided information to aviation stakeholders to address the challenges of climate change within the aviation community.
- 3) Aviation Impacts on Air Quality: The paper involved an update to the Aircraft Particulate Matter (PM) Emissions State of the Science white paper presented to CAEP/9, with a particular focus on PM caused by aircraft and their impacts on surface air quality. The updated paper contained information on measuring and modelling emissions, PM emissions from alternative fuel combustion, modelling emissions dispersion and concentrations, and cruise emissions impacts on air quality.
- 4) Aviation Noise Impacts: The new white paper summarized the state of knowledge on noise measurement and prediction and the relationship between aviation noise and community annoyance, children's learning, sleep disturbance and health impacts.

11.1.2 The co-Rapporteurs explained that the papers reflect the current level of scientific understanding on the respective subject areas. They felt that all of the papers are suitable for dissemination to the public, but noted that some topics, such as the effects of aviation on air quality and the global climate, are more mature than the work related to noise and the effects of climate change on aviation. In those areas where the science is still developing, the co-Rapporteurs highlighted that these papers may help to focus research activities. They noted that as scientific understanding improves, innovative approaches to mitigation can be developed.

11.1.3 On the topic of aircraft noise, a member called to the meeting's attention the "Noise-Related Annoyance, Cognition, and Health" (NORAH) study that had recently been completed in their State. The report is available from the website: <http://www.norah-studie.de/>

11.1.4 The meeting congratulated the ISG for their contribution to CAEP, noting that they provide a useful bridge between the scientific community and policy makers. Looking forward to future topics to which ISG may contribute, the meeting expressed interest in understanding how international aviation can fit within a carbon budget policy approach and how biofuels might fit within such a budget, and a review on whether the current definition of the LTO cycle adequately reflects air quality considerations. The meeting agreed to discuss these proposals during future work.

11.1.5 An observer supported the research that generates well-founded scientific knowledge on impacts especially health issues. However, it was highlighted that the Noise Impacts White Paper has the potential to be misinterpreted, because the sections were developed by authors who are health researchers who have their own perspectives and vocabulary possibly unfamiliar to aviation experts and outcomes reported in the paper could easily be taken out of context. It was stressed that should CAEP publish the paper, a caveat should be included stating that it is a summary of the views expressed by researchers. The observer offered to bring a new paper to SG2016 on non-acoustical factors, such as perception, attitude, complaint management, and work recently undertaken. The ISG co-Rapporteur noted the section summaries on noise impacts were very carefully worded to place the results in the appropriate context of our scientific understanding.

11.1.6 Two members highlighted that ISG should consider aviation noise impacts in the CAEP/11 cycle and identify scientific experts on noise impacts to participate in a Noise Impacts Workshop with members of WG1 and WG2, with a focus on updating the noise White Paper which would be presented to the CAEP/11 meeting. The members recommended that ISG, MDG, and WG3 take further steps to improve global aviation emission impact analysis that would be harmonized with approaches used for aircraft noise impact assessment by evaluating tools capable of considering cost benefit analysis (in future work). This would be discussed in future work (Agenda Item 12).

11.1.7 The Secretariat presented an overview of a scoping study into the Analysis of the Possible Effects of Climate Change on Air Navigation Services over the North Atlantic. This study was initiated by the 205th Session of the Joint Support Committee (JSC) and was approved by the ICAO Council. The scoping study assessed the existence, magnitude and consequences of phenomena for air navigation linked to climate change in the short, medium and long term.

11.1.8 An observer noted that the scoping study conducted by the Secretariat gave very valuable and robust data for the en route flight phase across the North Atlantic. The observer underlined the importance of these findings and those of the ISG on climate change impacts on aviation and supported future work on further assessment through ICAO. The local impact on operations on, and in the vicinity of airports, should also be considered.

Discussion and Conclusions

11.1.9 The meeting agreed that the ISG had completed its tasks for the CAEP/10 cycle and that the four white papers provided by ISG should be published by ICAO, with appropriate caveats and associated authorship. It was acknowledged that an appropriate method of publishing the four white papers could be through the ICAO Environmental Report.

11.1.10 The meeting acknowledged the good work conducted by the Secretariat on the Analysis of the Possible Effects of Climate Change on Air Navigation Services over the North Atlantic. The meeting encouraged further work on the topic to be funded, resources permitting. A member noted that the main text and the executive summary are not in complete alignment. The main text of the document notes that icing effects are speculative from a scientific level of understanding perspective but Figure 9.1 (of the document) indicates that icing has a high level of scientific uncertainty. If there is more funding

available then the member requested that it be used to ensure that the executive summary and main text match one another. She also offered to share many ideas on how to do the work in the future. The meeting agreed to consider the results of the scoping study when discussing its future work related to the effects of climate change on aviation. It was acknowledged that this study, and the ISG White Paper on climate impacts on aviation, would aid the work of WG2 and ISG on the adaptation of aviation to climate change and that further developments would be the result of an iterative process.

11.2 POTENTIALLY UPDATING THE 1999 SPECIAL REPORT BY THE IPCC ON AVIATION AND THE GLOBAL ATMOSPHERE

11.2.1 The ICAO Secretariat presented the available options to update the information contained within the Intergovernmental Panel on Climate Change (IPCC) *1999 Special Report on Aviation and the Global Atmosphere*. It was highlighted that the ICAO Secretariat and the ISG had proposed an update to the 1999 report at the SG2015 meeting. These included the following Options: 1) a new IPCC Special Report on Aviation and the Global Atmosphere; 2) a report initiated by ICAO/CAEP using leading academic institutions, 3) a New Special Report from the IPCC that is transport sector-wide in Scope; 4) a self-assembled group of scientists; and 5) utilising the expertise across ICAO and other UN agencies.

11.2.2 A member presented views on how the aviation community has been updating the information contained in the IPCC 1999 Special Report and how these efforts could continue in a pragmatic, effective manner. It was indicated that it was premature to ask the IPCC to update the 1999 report, noting that other means exist to provide independent peer reviewed scientific information to CAEP.

11.2.3 Several members and observers noted that the IPCC 1999 Special Report is somewhat outdated. However, almost half the contents of the report had been updated by CAEP itself. What was lacking is an assessment of the science of aviation impacts on climate, including non-CO₂ impacts. The members and observers considered that this could be achieved by the ISG providing further scientific updates of the IPCC Special report of 1999 applying the most efficient ways of using the limited sources of scientific expertise.

Discussion and Conclusions

11.2.4 The meeting discussed the ways and means of updating the information contained in the IPCC 1999 Special Report. Many members and observers highlighted the need to update the information contained in the report, however it was stressed that any method should not be resource intensive. It was suggested that Option 2) a report initiated by ICAO/CAEP using leading academic institutions, Option 4) a self-assembled group of scientists, and Option 5) utilising the expertise across ICAO and other UN agencies, could all be viable resource efficient options. An observer also acknowledged that the update would be timely, and a low cost option would be utilising the expertise across ICAO and other UN agencies, yet the credibility and usefulness of using the established IPCC processes should not be immediately discounted. It was also suggested that the options highlighted were not mutually exclusive and could be used in a complementary manner. Regarding the timescales, several members acknowledged that an appropriate timescale for an update would be aiming for completion in 2019.

11.2.5 The meeting agreed that it is premature to ask the IPCC to update the Special Report of 1999, and acknowledged that other means exist to provide independent scientific information to CAEP that is peer reviewed. Following a discussion, the meeting agreed that the method to be used to update the information contained in the IPCC 1999 Special Report would be a combination of Options 4 and 5, with

ICAO, building upon resources that could come from other UN agencies, scientific groups, and national research councils. The meeting agreed that the ICAO Secretariat would, in conjunction with ISG, formulate a plan by SG2016.

Agenda Item 12: Future work**12.1 CAEP STRUCTURE AND CAEP/11 WORK PROGRAMME**

12.1.1 The Secretariat presented a compilation of the potential CAEP/11 work items for the current working groups and task forces. This included information received from the CAEP working groups, members, observers, and the ICAO Secretariat. This information was presented, considered and modified by the 2015 CAEP Steering Group meeting and was subsequently revised by the final set of working group meetings in the CAEP/10 cycle. The lists also contained proposals included in working papers to the CAEP/10 meeting from members and some additional proposals from the ICAO Secretariat. The aim was to allow CAEP to consider resource availability when developing its future work programme, and so that discussions on the CAEP/11 work programme could focus on high-priority tasks.

12.1.2 The meeting discussed the priorities for the CAEP/11 work programme and the tasks were refined and appropriately resourced. The discussion highlighted three priorities for the CAEP members and observers:

- Policy options for an nvPM Standard;
- Completion of the remaining technical work related to the GMBM; and
- Support implementation of the ICAO aeroplane CO₂ Standard.

12.1.3 Based on the discussions during the meeting, the ICAO Secretariat also highlighted the following emerging issues:

- Guidance for adaptation to climate change;
- Guidance on aircraft recycling; and
- Placing international aviation into context with a 1.5°C/2.0°C temperature increase scenario.

12.1.4 The meeting agreed to the CAEP structure leading up to the CAEP/11 meeting, along with the co-Rapporteurs for each group. This information is provided in Appendix A to this agenda item. The Chairperson explained that subgroups could be created within the CAEP/11 working groups, as required.

12.1.5 The members and observers were requested to provide nominations to the working groups and task forces as soon as possible, noting that the first meeting of a CAEP working group will take place as early as March 2016. The meeting also encouraged the nomination of active scientists to the work of the Impacts and Science Group (ISG).

12.1.6 GMTF Future Work on Emissions Unit Criteria (EUC) and Interim Program Assessment Group

12.1.6.1 Several members proposed tasks and procedures to support the GMTF future work on Emissions Unit Criteria (EUC), in particular related to G.12 (EUC: Supply, Demand and Price of Units) and G.13 (EUC: Work on Early Action). The meeting agreed to reflect the proposal into the GMTF future work, as contained in Appendix B.

12.1.6.2 The meeting also agreed to constitute an Interim Programme Assessment Group (IPAG) to undertake assessment of Emissions Unit Programs (and potentially project types) under the umbrella of the GMTF, for the purpose of forming an early decision on Emissions Unit Programmes (and potentially project types) eligibility. The meeting agreed that the IPAG would:

- a) implement EUC group recommendations, in coordination with but independent from the EUC group;
- b) be nominated from, and approved by, State or regional economic integration organizations, on the basis of Terms of Reference (TORs) to be elaborated by CAEP (with support as needed from GMTF, and with consideration to existing EUC group recommendations for TORs provisions, in particular requesting CAEP to avoid conflicts of interest and ensure appropriate expertise);
- c) serve until the EUC's recommended standing technical advisory body is formed;
- d) be constituted in time for and observe EUC deliberations at GMTF/8;
- e) solicit, assess, and recommend to CAEP the eligibility of Emissions Unit Programs (and potentially project types) for ICAO's global MBM for a time-bound period;
- f) implement this decision-making process as recommended by the EUC group;
- g) base this decision-making process on eligibility criteria as recommended by the EUC group, and taking into account any future recommendations;
- h) communicate this decision-making process as recommended by the EUC group, to ensure outreach to all potentially eligible programs; and ample opportunity for input from and transparency for civil society and other stakeholders;
- i) raise any technical issues related to decision-making process to the EUC group for further consideration (revisions to EUC group's recommended criteria and other guidance to be reviewed by EUC and CAEP prior to execution by the IPAG);
- j) following the 2016 Assembly, and if necessary, harmonize draft list of recommended Emissions Unit Programmes (and potentially project types) with relevant features of the final global MBM Assembly Resolution;
- k) deliver draft list of recommended Emissions Unit Programs (and potentially project types) to CAEP SG for consideration in November 2016;
- l) reconvene for additional reviews according to the decision-making process recommended by the EUC group; and

m) other functions and features as defined in forthcoming TORs.

12.1.6.3 An observer enquired regarding the status of the 2016 ICAO Environmental Report. The CAEP/10 meeting had delivered important results and the ICAO Environmental Report was the only publication that translates this complex work into a language that is accessible to the public. The ICAO Secretariat highlighted that the new edition of the ICAO Environmental Report would be published before the 39th Assembly. The meeting noted that this had been a useful publication and reference document in the past, and encouraged all members and observers to contribute.

12.1.6.4 The meeting recognised that the United Nations Sustainable Development Summit in New York marked the adoption of the 17 United Nations Sustainable Development Goals (UN SDGs). It was noted that the ICAO Secretariat will map the new CAEP work programme against the SDGs and its relevant indicators, and identify how the deliverables would contribute to such SDGs, in consultation with the relevant groups. The ICAO Secretariat would present this report to the first CAEP/11 Steering Group meeting.

12.1.6.5 The meeting discussed all of the potential CAEP/11 future work items, and those tasks that were fully scoped and had the appropriate level of resourcing were agreed to be included in the CAEP/11 work programme. The approved work programme items are shown in Appendix B to the report on this agenda item.

12.1.7 Recommendation

12.1.7.1 In light of the foregoing discussion, the meeting developed the following recommendation:

Recommendation 12/1 — CAEP/11 work programme

That the Council approve the revised work programme of CAEP contained in Appendix B to the report on this agenda item.

12.2 CALENDAR

12.2.1 The meeting discussed the locations and dates of the CAEP Steering Group meetings during the CAEP/11 cycle while recognizing the Council recommendation to hold these meetings in Montreal. The members and observers requested that the CAEP Steering Group meetings be held in the regions. This would enable the CAEP to maintain its strong global outreach and will allow effective participation from all of the members and observers. It was noted that by continuing to hold the CAEP Steering Group meetings at ICAO Headquarters in Montreal, participation may be limited. Also, members and observers have invested many resources into the work of CAEP and they expressed that it should be expected that Secretariat resources would also be available to support this work adequately. The meeting recognised offers from the United States, Spain and Singapore to host CAEP/11 Steering Group meetings.

12.2.2 The meeting agreed to hold the following Steering Groups prior to the CAEP/11 meeting:

- a) United States, 28 November – 2 December 2016 (TBC). It was recognised that this date would give time for the working groups to progress their work items. It was agreed that this would be the earliest possible date for the 2016 Steering Group meeting.
- b) Spain, 11 to 15 September 2017 (TBC);
- c) Singapore, 4 to 8 June 2018 (TBC).

12.2.3 The full calendar leading up to the CAEP/11 meeting will be agreed by the first Steering Group meeting in 2016. The CAEP/11 meeting is planned for February 2019.

12.3 CLOSING REMARKS

12.3.1 In closing the meeting, the CAEP Secretary thanked the members and observers, their advisors and the working group co-rapporteurs, for their dedication to the work of CAEP. She also thanked the Chairperson and the ICAO Environment staff for their support and professionalism. She congratulated members and observers on the agreement of two new environmental Standards during CAEP/10, acknowledging that this was a first for ICAO.

12.3.2 The CAEP Secretary highlighted that before and during this meeting there had been leaks of confidential CAEP information. Specifically, confidential information from the meeting documentation had been published in a few newspapers and on public websites. This represented a breach of the principle that information submitted to CAEP is confidential and should only be used by CAEP members, observers and those experts nominated to participate in CAEP working groups. The CAEP Secretary stated that, during CAEP/11, the ICAO Secretariat would increase efforts to protect the material contained within CAEP documentation. This would involve 1) clearing all the current users from the CAEP Secure portal websites in order to ensure that only those nominated for the CAEP/11 cycle will have access to meeting documentation; 2) further enhancing and enforcing the user agreement currently in use for all CAEP Secure Portals which outlines the confidentiality of the material in CAEP documentation; and 3) requiring new CAEP participants to receive training on basic rules ensuring that the CAEP procedures are understood. She informed that currently she was consulting with ICAO Legal Bureau to define the action that needs to be undertaken regarding the individuals responsible for the breach of information.

12.3.3 It was highlighted that the observers from Indonesia and the United Arab Emirates contributed significantly to the work of CAEP over two CAEP cycles. As per the CAEP Directives, the two observers could apply for CAEP member status and this would be considered by the Council in the coming months.

12.3.4 The meeting recognised the contributions from Mr. Roger Worth (UK) and Ms. Julie Marks (US). Mr. Worth, as WG3 co-Rapporteur, had been instrumental in the development of both the nvPM and CO₂ Standards, and Ms. Marks, as WG2 co-Rapporteur, had contributed significantly to the work of CAEP on airports and operations. The meeting participants wished them success in their new endeavours.

12.3.5 The CAEP members and observers expressed their gratitude to Dr. Lourdes Maurice, the outgoing member for the United States for her significant contribution to the work of CAEP as head of the United States' delegation.

12.3.6 The meeting participants congratulated the Chairperson for his conduct of the tenth meeting of the ICAO Committee on Aviation Environmental Protection.

12.3.7 The Chairperson thanked CAEP members and observers for their diligent efforts and formally closed the meeting.

Appendix A
(English only)

CAEP STRUCTURE LEADING UP TO CAEP/11

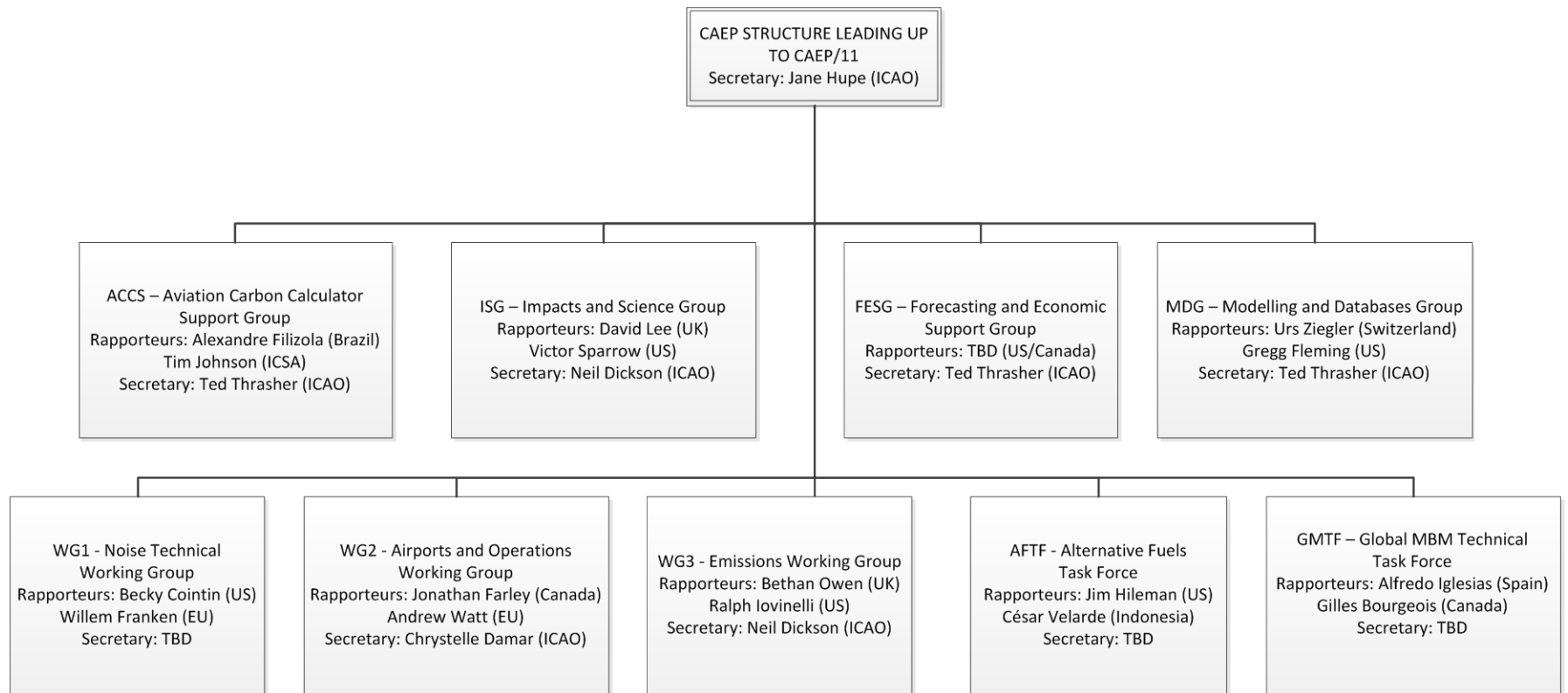

APPENDIX B
(English Only)

CAEP/11 WORK PROGRAMME

CAEP/11 Working Group 1 - Noise Technical - Work Programme				
Resources offered by: Canada, France, Italy, Japan, Sweden, United States, Norway, Peru, EU, IBAC, ICCAIA, ICSA				
Task Number	Task Title	Task Description	Deliverables	Deliverable Date
N.01	Coordination	Coordinate with other working group Rapporteurs on + interdependencies related to technology, operational issues, and goals as well as harmonizing the goal setting process. + interdependencies related to management and update of noise and emissions databases + interdependencies related to environmental impacts, including stringency + programmes for development of both noise and emissions SARPs for future supersonic aeroplanes	Coordination	Ongoing
N.02	Annex and ETM maintenance	Maintain and update Annex 16, Vol. I and ETM, Vol. I.	Updates to ETM	SG2018
			Updates to Annex 16	CAEP/11
N.03	NoisedB	Ensure process integrity and data currency of the ICAO noise certification database.	Up-to-date ICAO NoisedB	Ongoing
N.04.01	Monitor research and development	Monitor and report on the various national and international research programme goals and milestones. Review data on emerging technologies as it becomes available.	Report	CAEP/11
N.05.01	Monitoring Sonic Boom research	Monitor and report on research to characterize, quantify and measure (including metric) climb and en route noise from supersonic flight, including Mach cut-off conditions, and its acceptability while also assisting in promoting and defining such research.	Report	CAEP/11

CAEP/11 Working Group 1 - Noise Technical - Work Programme				
Resources offered by: Canada, France, Italy, Japan, Sweden, United States, Norway, Peru, EU, IBAC, ICCAIA, ICSA				
Task Number	Task Title	Task Description	Deliverables	Deliverable Date
N.05.02	SST standards development (subsonic and supersonic regime)	Continue to work on noise certification standards for supersonic aircraft: 1) based on subsonic noise standards for local airport noise that may include the use of Variable Noise Reduction System (VNRS) technology as “acceptable means of compliance.” and 2) a new scheme for supersonic flight, as informed by developments under N.5.01.	Progress report	CAEP/11
N.05.03	SST coordination	Update Air Navigation Commission with SSTG Report on progress of SST noise activities.	Briefing to ANC	May/June 2016
N.05.04	Monitoring SST projects	Monitor, and report on, status of SST projects and expectations of supersonic development.	Report	CAEP/11
N.06.01	Support: Understanding the effects of standards on the evolution of the global fleet	Support MDG in an analysis to allow for a better understanding of whether standards are driving the desired behaviours and what are the potential influences from other factors; e.g., fuel price changes, global economic downturn, etc.	Support	
N.06.02	Support: Global Aviation Environmental Plan (GAEP)	Support the Secretariat in developing a Global Aviation Environmental Plan (GAEP). Similar to the Global Air Navigation Plan (GANP), this would allow for a schedule of planned Annex 16 amendments to be developed in a coordinated manner. It is recommended that the proposed noise and emissions technology reviews serve as the basis for the development of the GAEP.	Support	Ongoing
N.07.01	UA noise monitoring	Monitor developments around UA noise and where appropriate suggest specific work items to SG.	Report	
N.07.02	UA noise certification	Develop proposals for a non-zero lower weight for applicability of noise requirements in Annex 16.	Proposal for Change	
N.08.01	Helicopter Noise Correlation	Investigate the feasibility of correlating certification noise levels with operational noise levels to better assess the helicopter noise certification scheme and its relevance to day-to-day operations, similar to the studies done for jets.	Report	SG2017

CAEP/11 Working Group 1 - Noise Technical - Work Programme				
Resources offered by: Canada, France, Italy, Japan, Sweden, United States, Norway, Peru, EU, IBAC, ICCAIA, ICSA				
Task Number	Task Title	Task Description	Deliverables	Deliverable Date
N.08.02	Helicopter Hover Noise	Review any past evaluations of a noise certification scheme for the hover condition, and assess whether the current helicopter noise certification scheme is applicable for assessing hover noise including the sufficiency of a correlation with one or more of the existing reference conditions.	WP to SG2017	SG2017
N.09	Integrated IE Technology Goals Assessment and Review for Engines and Aircraft	In coordination with WG3, conduct an Independent Expert (IE) Technology Assessment and Review. <u>Engine Level:</u> Provide assessment of combustion technology including both NO _x and nvPM, and consider within the context of existing CAEP Standards and CAEP NO _x goals. <u>Aircraft Level:</u> Provide assessment of aircraft subsonic technologies including both fuel efficiency and noise. Consider these in the context of the existing CAEP Standards and CAEP goals.	Proposed way forward to SG2016 Report	CAEP/11
N.10	Applicability for derived versions of recertified aeroplanes	Review of the applicability language in Chapter 4 and Chapter 14 regarding the required Standards for derived versions of recertified aeroplanes.	Report to SG2016 on result of the review and implications of amendments being considered Proposed Amendments to Annex 16, Vol. I and ETM pending decision by SG2016	CAEP/11

CAEP/11 Working Group 2 - Airports and Operations - Work Programme				
Resources offered by: Argentina, Australia, Canada, China, France, Italy, Russian Federation, Singapore, Sweden, United Kingdom, United States, Greece, Peru, ACI, CANSO, EU, IBAC, ICSA				
Task Number	Task Title	Task Description	Deliverables	Deliverable Date
O.01	Environmental Community Engagement for PBN	To gather information on PBN implementation challenges, needs and potential solutions, including methods for cross-industry collaboration and structured community engagement, leading to the creation of a report to SG2.	<ol style="list-style-type: none"> 1. Compilation of a body of information on issues with PBN implementation; 2. Identification of any gaps/needs and recommended next steps to supplement the recently published WG2 Community Engagement Circular and the appropriate format; 3. Development of proposals on how to disseminate the deliverables 	CAEP/11
O.02	Operational Opportunities to Reduce Aircraft Noise	Developing a document, similar to ICAO Document 10013 “Operational Opportunities to Reduce Fuel Burn and Emissions”, but for noise emissions. The task will be aimed at identifying and highlighting good practices and the operational opportunities to minimise aircraft noise from aircraft operations where practicable and operationally safe to do so.	<ol style="list-style-type: none"> 1. Framework of topic chapters; 2. Reference material; 3. Report to CAEP on further work that may be required 	Draft report to CAEP/11 Final report to CAEP/12
O.03	Operational Interdependencies - Assessment of Interrelationships Information	Operational Interdependencies - Assessment - Continuation of CAEP/10 Task O.02 to perform an assessment of the interrelationships information found in the ICAO documents, in order to identify any inconsistencies and/or gaps and make recommendations for improvement where appropriate.	Report to SG	SG2017

CAEP/11 Working Group 2 - Airports and Operations - Work Programme				
Resources offered by: Argentina, Australia, Canada, China, France, Italy, Russian Federation, Singapore, Sweden, United Kingdom, United States, Greece, Peru, ACI, CANSO, EU, IBAC, ICSA				
Task Number	Task Title	Task Description	Deliverables	Deliverable Date
O.04	Aviation System Block Upgrade (ASBU) Block 1 Analysis	ASBU Block 1 - Continue the ASBU Analysis task thread into CAEP/11 with the intent of analyzing the potential environmental benefits of the current and planned implementation of ASBU Block 1 modules.	At CAEP/11, report on environmental assessment of the benefits that may be generated following planned implementation of the Block 1 modules	CAEP/11
O.05	Improved Static ATM and Aircraft Technology scenario	Improved Static ATM and Aircraft Technology scenario - Carry out a top-down analysis to identify the levels of ATM inefficiency that need to be bridged and where the ASBU module implementations should be targeted. This analysis will carry on from the work undertaken during the CAEP/8 cycle.	At SG1, feasibility study based on a literature review to determine what data and methodologies are available. If feasibility is demonstrated, then the following deliverables are envisaged potentially for CAEP/11: a) New figures for estimated global (in)efficiency, preferably broken down to the regional level and b) A new estimate of the static ATM do-nothing case	SG2016 CAEP/11
O.06	New APM Part II appendices	APM Part II appendices - Continuation of CAEP/10 Task O.06 to complete: a) updates to remaining chapters based on CAEP/10 review, and b) new Chapters on Heritage Considerations and Climate Change Resilience and Adaptation, and 3 new appendices for the APM Part 2. Appendix 1 will include case studies of airport infrastructure for environmental management, Appendix 4 will include case studies of heritage management and Appendix 5 will include case studies of climate adaptation.	Three new appendices for the APM Part II	SG2018

CAEP/11 Working Group 2 - Airports and Operations - Work Programme				
Resources offered by: Argentina, Australia, Canada, China, France, Italy, Russian Federation, Singapore, Sweden, United Kingdom, United States, Greece, Peru, ACI, CANSO, EU, IBAC, ICSA				
Task Number	Task Title	Task Description	Deliverables	Deliverable Date
O.07	Climate Adaptation Synthesis	To synthesise existing information on the range of projected climate impacts for the aviation sector to better understand risks to airport and ANSP planning, infrastructure and operations, <i>including bringing to the attention of the relevant ICAO bodies</i> how they relate to safety, capacity and efficiency.	CAEP Report with synthesis and recommended next steps	CAEP/11
O.08	"Green Your Airport" e-collection	A set of practical and ready-to-use information, to support the planning and implementation of airport infrastructure projects. Each publication will focus on a specific aspect of environmental planning at airports.	A series of short publications accessible from ICAO Environment website, forming an e-collection.	Ongoing
O.09	Aircraft end of life and recycling	Assess and collate the current best practices on aircraft end of life management techniques and recommend guidance material.	Report and Guidance material	CAEP/11
O.10	Aviation and Global Atmosphere update	Contribute to an update to the information.	Ongoing support	Ongoing
O.11	Update to Doc 9889	Support WG3 in an update of ICAO Doc 9889 to replace emissions technical information that is now out-of-dated)	Input to WG3 on operations-related aspects of Doc 9889	As required, final updated document by CAEP/11
O.12	Support to ICAO Secretariat	Continue support ICAO Secretariat in communicating the results of tasks from WG2, including ASBU analysis and update to APM.	ASBU analysis results. Comments on APM.	As required

CAEP/11 Working Group 3 - Emissions Technical - Work Programme				
Resources offered by: Canada, China, France, Germany, Japan, Spain, Switzerland, United Kingdom, United States, United Arab Emirates, ACI, EU, IATA, IBAC, ICCAIA, ICSA				
Task Number	Short Title	Task Description	Deliverables	Deliverable Date
E.01	Interdependencies	Coordinate with other working group Rapporteurs on interdependencies related to (a) technology, operational issues and goals (b) management and update of noise and emissions databases (c) environmental impacts (d) SARPs for future SST aircraft.	Coordination report for each SG	Ongoing
E.02	Fuel composition and emissions	Monitor trends in 1) petroleum-based aviation kerosene fuel supply composition, 2) aviation alternative fuel based kerosene fuel supply, and 3) blended fuel types. Assess consequences for emissions and emissions certification. Including a global survey of fuel sulphur content to support the estimation of global and regional SOx emissions.	Report	During CAEP/11
E.03	Emissions Certification requirements – new aeroplane applications and concepts	Monitor developments in aeroplane and engine applications and concepts, such as freighter applications or technology developments e.g. blended wing body, or non-classical tube and wing configurations and open-rotor engines etc., and develop methodologies for emissions certification.	Report	CAEP/11
E.04	Annex 16 maintenance for emissions	Maintain Annex 16 on emissions.	Proposed Annex changes	CAEP/11
E.05	Emissions ETM maintenance	Maintain Emission Environmental Technical Manual.	Proposed ETM changes	CAEP/11
E.06	Emissions Databank maintenance	Maintain emissions certification databank.	up-to-date databank	CAEP/11
E.07	G&R database maintenance	Review and update a "Growth & Replacement" database in order to support development of models used to populate future fleets and the replacement of retired aircraft. Coordinate with PMTG, WG1 and support groups to ensure consistency in assumptions.	up-to-date G&R databank	During CAEP/11

CAEP/11 Working Group 3 - Emissions Technical - Work Programme				
Resources offered by: Canada, China, France, Germany, Japan, Spain, Switzerland, United Kingdom, United States, United Arab Emirates, ACI, EU, IATA, IBAC, ICCAIA, ICSA				
Task Number	Short Title	Task Description	Deliverables	Deliverable Date
E.08	NOx cruise - Climb relationship	Review the LTO NOx - cruise climb NOx relationship for staged combustion and future engine technologies, to quantify control of mission emissions of NOx, and identify any methodology issues with respect to the correlation between LTO and climb/cruise and to quantify interdependencies with other emissions.	Report	CAEP/11
E.09	Certification Requirements - SST	Monitor trends in supersonic technology and assess consequences for engine based emissions and certification standards.	Proposed change to Annex 16	CAEP/11
E.10	Modelling emissions at low power	Provide guidance to MDG on the modelling of emissions at low power settings.		
E.11.01	PM - Non-volatile	Provide representative engine data for assessing the nvPM emissions standard for mass and number regarding turbofan/turbojet engines $\geq 26.7\text{kN}$ by February 2017. Provide recommendations on technology responses, stringency options and applicability [new types and in-production] to SG2017.	Report	By Feb 2017
E.11.02	PM - Non-volatile	Develop an aircraft engine based LTO nvPM mass and number standard for turbofan/turbojet engines $\geq 26.7\text{kN}$.	Annex 16, Vol. II	During CAEP/11
E.11.03	PM - Non-volatile	Investigation the possible replacement of the smoke number standard for engine categories $\geq 26.7\text{kN}$ and other engine categories $< 26.7\text{kN}$.	Annex 16, Vol. II	During CAEP/11
E.11.04	PM - Non-volatile	Develop improved nvPM model inputs to both local air quality models and, as required, global climate models per advice from ISG. Including the investigation into the apportionment of PM emissions for engines $< 26.7\text{kN}$, $\geq 26.7\text{kN}$, helicopter engines and Auxiliary Power Units (APUs) etc.. Continue collaborative work with MDG. Note input from ISG on nvPM impacts.	WG3 Report	During CAEP/11

CAEP/11 Working Group 3 - Emissions Technical - Work Programme				
Resources offered by: Canada, China, France, Germany, Japan, Spain, Switzerland, United Kingdom, United States, United Arab Emirates, ACI, EU, IATA, IBAC, ICCAIA, ICSA				
Task Number	Short Title	Task Description	Deliverables	Deliverable Date
E.12	Update and Review Doc 9889	Update Doc 9889 to reflect industry best practices, new emissions data for modern aircraft and airport emission sources, airport operational information that affect aviation emissions, and emissions modelling methodologies.	Updated Doc 9889	CAEP/11
E.13	Properties of Engine Black Carbon Emissions	Measurements to support ISG in answering questions regarding the size and size distribution, density, morphology and internal structure of nvPM and Black Carbon emissions from aircraft engines.	Report	SG2016
E.14	Integrated IE Technology Goals Assessment and Review for Engines and Aircraft	In coordination with WG1, conduct an Independent Expert (IE) Technology Assessment and Review. <u>Engine Level</u> : Provide assessment of combustion technology including both NOx and nvPM, and consider within the context of existing CAEP Standards and CAEP NOx goals. <u>Aircraft Level</u> : Provide assessment of aircraft subsonic technologies including both fuel efficiency and noise. Consider these in the context of the existing CAEP Standards and CAEP goals.	Report	CAEP/11
E.15	Aviation and Global Atmosphere update	Contribute to an update to the information.	Plan for SG2016 Report to CAEP/11	Ongoing
E.16	Understanding the effects of standards on the evolution of the global fleet	Support MDG in an analysis to allow for a better understanding of whether standards are driving the desired behaviours and what are the potential influences from other factors; e.g., fuel price changes, global economic downturn, etc.	Comprehensive Fleet Evolution Study Report, Interim Analyses and Final Report	SG1 – Comprehensive Fleet Evolution Study Report, SG2- Fleet Database, SG-3 Preliminary analyses, CAEP/11 – Final Report

CAEP/11 Working Group 3 - Emissions Technical - Work Programme				
Resources offered by: Canada, China, France, Germany, Japan, Spain, Switzerland, United Kingdom, United States, United Arab Emirates, ACI, EU, IATA, IBAC, ICCAIA, ICSA				
Task Number	Short Title	Task Description	Deliverables	Deliverable Date
E.17	Global Aviation Environmental Plan (GAEP)	Support the Secretariat in developing a Global Aviation Environmental Plan (GAEP). Similar to the Global Air Navigation Plan (GANP), this would allow for a schedule of planned Annex 16 amendments to be developed in a coordinated manner. It is recommended that the proposed noise and emissions technology reviews serve as the basis for the development of the GAEP.	Report	CAEP/11
E.18	Follow-On CO ₂ Standard Remits	Complete the work related to the implementation of CO ₂ Standards; Finalisation of CO ₂ standard exemption process and ETM Vol. III text by CAEP SG2016. Finalisation of CO ₂ Certification Database structure providing views on potentially incorporating information of exempted aeroplanes by CAEP SG2017.	Revised ETM, Vol. III; CO ₂ Certification Database	SG2016; SG2017

CAEP/11 Aviation Carbon Calculator Support Group (ACCS) Work Programme				
Resources offered by: Brazil, ICSA				
Task Number	Short Title	Task Description	Deliverables	Deliverable Date
C.01	Obtain Aviation Offset Data	Assist ICAO in collecting data on offsets used for aviation including mandatory MBMs, large offset providers, and voluntary airline schemes.	List of available sources	SG2016: Initial list SG2017: Updated list SG2018 Updated list
C.02	Enhancements to Passenger Carbon Calculator	Review publicly-available data sources and the current passenger methodology to identify areas of improvement.	Recommendations for enhancements to the Calculator to be implemented by the Secretariat	SG2017
C.03	Enhancement to Cargo Carbon Calculator	Based on experiences from implementing the cargo calculator methodology developed during the CAEP/10 cycle, identify areas of improvement.	Recommendations for enhancements to the cargo calculator methodology	SG2017

CAEP/11 Forecasting and Economic Analysis Support Group (FESG) Work Programme				
Resources offered by : Canada, France, Switzerland, United Kingdom, United States, ACI, EU, IATA, ICCAIA, ICSA				
<i>Note: Meetings of FESG and MDG are to be held back-to-back during CAEP/11</i>				
Task Number	Task Title	Task Description	Deliverables	Deliverable Date
F.01	Review of Economic Models	Review of economic models as needed for the CAEP/11 analyses. A review of the underlying economic cost assumptions used in the fleet evolution modelling tools is needed. These include crew, route, capital, and landing costs, all of which will need to be re-estimated and updated in concert with the development of a new fleet forecast.	Report	SG2018 CAEP/11
F.02	New CAEP Forecast consistent with the long-term traffic forecasts developed by the ADAP MDWG-LTF	Develop a new CAEP forecast in support to the CAEP/11 analyses (e.g. passenger aircraft and freighter fleet forecasts, forecast for aircraft with less than 20 seats, retirement curves) using as an input the long-term (passenger and cargo) traffic forecasts developed by the ADAP MDWG-LTF.	Forecast and Report	SG2017
F.03	Analysis lessons learned	Conduct a review of lessons to be learned from prior analyses, with a view toward improving the process for future economic assessment of stringency options.	Report	SG2016
F.04	Cost-effectiveness analysis of potential PM policy options	Conduct the cost-effectiveness analysis of the potential particulate matter (PM) policy options under consideration for CAEP/11.	Draft Report Final Report	SG2018 CAEP/11
F.05	ADAP Participation	FESG/MDG to ensure coordination with the ICAO Aviation Data and Analysis Panel (ADAP) Multi-Disciplinary Working Group on Long-Term Traffic Forecasts (MDWG-LTF).	Status report	Per ADAP MDWG-LTF schedule
F.06	Aviation and Global Atmosphere update	Contribute to an update to the information.	Plan for SG2016 Report to CAEP/11	Ongoing
F.07	Evaluation of CBA	Evaluation of how cost-benefit assessment might support decision-making in CAEP.	Report	CAEP/11

CAEP/11 Modelling and Databases Group (MDG) Work Programme				
Resources offered by : Canada, China, Germany, Russian Federation, Switzerland, United Kingdom, United States, Indonesia, ACI, IATA, ICCAIA, UNFCCC				
<i>Note: Meetings of FESG and MDG are to be held back-to-back during CAEP/11</i>				
Task Number	Task Title	Task Description	Deliverables	Deliverable Date
M.01	Interdependencies	Coordinate with other working group Rapporteurs on interdependencies related to technology, operational issues, goals, environmental impacts and management and update of noise and emissions databases.	Coordinated WP	Each SG meeting and final report to CAEP/11
M.02	Analysis lessons learned	Conduct a review of lessons to be learned from prior analyses, with a view toward improving the process for future analyses. This should include an identification of gaps in analysis assumptions, databases and tools.	Report	SG2016
M.03	ICAO Environmental Trends Projection	<p>Conduct an updated trends projection, for the 201x baseline case and forecasts, for various cases which consider technology, operational improvements (both infrastructure and operator-initiated improvements) and alternative fuels life cycle, for noise, NOx, PM, fuel burn, and CO2. The trends projection will support the display of the following information, as appropriate:</p> <ol style="list-style-type: none"> 1. A static ATM (informed by WG2) and static aircraft technology scenario 2. Progress being achieved toward the ICAO global aspirational environmental goals (i.e. 2% annual fuel efficiency improvement and carbon neutral growth from 2020) 3. Anticipated progress toward the goals based on the information communicated by States in their voluntary Action Plans 4. Additional efforts that would be required to meet those goals (i.e. feasibility analysis results) 5. The effects of ASBU Block 0 and 1 implementation <p>The MDG fuel trends results will be published in a Structured Query Language (SQL) database that could be easily accessed by experts from other CAEP groups.</p>	Report that include graphical depiction of the trends and database	CAEP/11
M.04	Identification of Assessment Tools	MDG in concert with ISG identify and evaluate tools for including noise, LAQ and GHG impacts (including monetization) tools for use as part of future CAEP assessments.		CAEP/11

CAEP/11 Modelling and Databases Group (MDG) Work Programme				
Resources offered by : Canada, China, Germany, Russian Federation, Switzerland, United Kingdom, United States, Indonesia, ACI, IATA, ICCAIA, UNFCCC				
<i>Note: Meetings of FESG and MDG are to be held back-to-back during CAEP/11</i>				
Task Number	Task Title	Task Description	Deliverables	Deliverable Date
M.05	Existing Model and Database Management	<p>Maintain version control of models and databases to be used in support of specific CAEP analyses. Determine if updates to models or databases require a re-evaluation, including providing feedback to the ICAO Secretariat regarding databases to be used in CAEP that they maintain. In support of the CAEP/11 work programme, the following specific enhancements to air quality and or greenhouse gas models have been identified:</p> <ol style="list-style-type: none"> 1. Ability to model nvPM over the full flight regime (in conjunction with WG3) 2. Enhancement and standardization of low-power setting emissions modelling 3. Emissions dispersion modelling <p>In support of the CAEP/11 work programme, the following specific enhancements to the fleet database have been identified: 1. a more complete set of smaller aircraft (e.g. business jets, turbo-props and helicopters), 2. payload and seat information harmonization – which often propagates to the related growth and replacement database –, and 3. the better tracking and monitoring of business jet tail numbers which are included in the COD as flight IDs would all add significant value.</p>	<p>Updated models and databases</p> <p>Progress report</p>	<p>Each SG meeting and final report to CAEP/11</p>
M.06	New Model Evaluation	<p>If new models are introduced to support CAEP/11, continue the candidate model evaluation process, which calls for sensitivity tests, comparisons with “gold standard data, and sample problems. Refine the process as appropriate on the basis of relevant criteria, to better inform CAEP which tools are sufficiently robust, rigorous and transparent, and appropriate for which analysis, and why there might be differences in modelling results.</p>	<p>Report</p>	<p>As model evaluations are complete</p> <p>Final report to CAEP/11</p>

CAEP/11 Modelling and Databases Group (MDG) Work Programme				
Resources offered by : Canada, China, Germany, Russian Federation, Switzerland, United Kingdom, United States, Indonesia, ACI, IATA, ICCAIA, UNFCCC				
<i>Note: Meetings of FESG and MDG are to be held back-to-back during CAEP/11</i>				
Task Number	Task Title	Task Description	Deliverables	Deliverable Date
M.07	Doc 9911 Update	Update ICAO Doc 9911 as required. Potential areas for update that should be scoped out and considered (in coordination with WG1 and ISG) include: 1. full ICAO Doc. 9911 harmonization and implementation across all models, including implementation of the extended level line segment, the latest start-of-take-off roll directivity, and speed-varying effects on noise-power-distance (NPD) curves; 2. standard approaches for modelling of helicopter noise; 3. modelling of reduced thrust departures; 4. sonic boom modelling; 5. noise modelling for commercial space vehicles and unmanned aerial vehicles(UAV) ; and 6. improved noise propagation modelling, possibly including terrain effects	Updated Doc 9911	CAEP/11
M.08	New Emissions Database	In cooperation with WG3, develop a comprehensive database of aircraft emissions indices by operating mode within the LTO cycle for CO, HC, NOx, PM, Fuel Flow, and CO2 for all aircraft types observed in the COD. The database would augment the ICAO Engine Exhaust Emissions Databank and would support CAEP analyses and external model developers.	Database	SG2017
M.09	ICAO Support	Provide support to ICAO Secretariat in dissemination of MDG results.	As requested	As requested
M.10	PM Standard	Conduct sample problem and policy option analyses of the environmental benefits and interdependencies of a potential PM standard as directed by CAEP and SG. In cooperation with other CAEP WG's.	Report	CAEP/11
M.11	ASBU Analysis	Estimate the benefits from the implementation of ASBU Block 1 for display on the updated trends assessment charts (with an emphasis on fuel burn and CO2, and consideration for noise and LAQ, if feasible based on the analysis). Note: WG2 has the lead on this task and the success of this task is dependent on receiving sufficient and timely input from States.	Report	SG2018

CAEP/11 Modelling and Databases Group (MDG) Work Programme				
Resources offered by : Canada, China, Germany, Russian Federation, Switzerland, United Kingdom, United States, Indonesia, ACI, IATA, ICCAIA, UNFCCC				
<i>Note: Meetings of FESG and MDG are to be held back-to-back during CAEP/11</i>				
Task Number	Task Title	Task Description	Deliverables	Deliverable Date
M.12	COD Improvement(s)	<p>Develop and maintain a 201x Common Operations Database (COD) (preferably including a full 52-weeks of operations) and manage the acquisition and treatment of additional State data. Two versions of the COD will be maintained:</p> <ol style="list-style-type: none"> 1. A version that can be used by the ICAO Secretariat and those States who contribute data to the COD, with sensitive data removed or deidentified; and 2. A version that is limited to those organizations who have signed an appropriate agreement <p>This task will also include a comparison of the COD and WISDOM, e.g. using 2012 traffic, and identify areas of improvements in the process applied to generate the databases. Further work could be undertaken to refine and harmonise the description of aircraft in the base year operations (airframe, engine, age, seat / freight capacity), which would help improve the fidelity of the future fleet and operations forecast.</p>	Database	SG2017
M.13	Feasibility of ICAO climate change goals	(If requested by A39) Analysis of the feasibility of achieving ICAO goals for international aviation and climate change, based on the updated trends generated in Task M.03.	Draft Report Final Report	SG2017 CAEP/11
M.14	ADAP Participation	FESG/MDG to ensure coordination with the ICAO Aviation Data and Analysis Panel (ADAP) Multi-Disciplinary Working Group on Long-Term Traffic Forecasts (MDWG-LTF).	As requested	As requested
M.15	Airports Database	Augment the data included in ICAO Doc 7910 (Location Identifiers) to add information required to support CAEP analyses, in cooperation with the ICAO Secretariat and relevant panels.	Airports database	Prior to the start of analyses requiring the data
M.16	GMBM Support	Provide technical support in the development of a global market-based measure for international aviation, as requested.	As requested	As requested

CAEP/11 Modelling and Databases Group (MDG) Work Programme				
Resources offered by : Canada, China, Germany, Russian Federation, Switzerland, United Kingdom, United States, Indonesia, ACI, IATA, ICCAIA, UNFCCC				
<i>Note: Meetings of FESG and MDG are to be held back-to-back during CAEP/11</i>				
Task Number	Task Title	Task Description	Deliverables	Deliverable Date
M.17	CO ₂ Goals Assessment	Conduct a scoping exercise to assess the contribution of CO ₂ Standard to ICAO global aspirational goals in CAEP/11 cycle.		CAEP/11
M.18	Understanding the effects of standards on the evolution of the global fleet	Conduct an analysis to allow for a better understanding of whether standards are driving the desired behaviours and what are the potential influences from other factors; e.g. fuel price changes, global economic downturn, etc.	Comprehensive Fleet Evolution Study Report, Interim Analyses and Final Report	SG1 – Comprehensive Fleet Evolution Study Report, SG2- Fleet Database, SG-3 Preliminary analyses, CAEP/11 – Final Report
M.19	Aviation and Global Atmosphere update	Contribute to an update to the information.	Plan for SG2016 Report to CAEP/11	Ongoing
M.20	Feasibility of ICAO climate change goals	ISG, AFTF, MDG to scope work for putting international aviation emissions into the context of a 1,000 Gt budget (1.5/2°C scenario).	Scope of work	SG2016

CAEP/11 Impacts and Science Group (ISG) Work Programme				
Task Number	Task Title	Task Description	Deliverables	Deliverable Date
I.01.01	Coordination (internal group)	Coordination on activities.	Coordination	Ongoing
I.01.02	Coordination (internal ICAO)	Coordination with other WGs, TFs, RFPs, etc. Rapporteurs and ICAO Secretariat on activities.	Coordination	Ongoing
I.01.03	ISG membership	As per the ISG Terms of Reference, the ISG co-rapporteurs, in conjunction with the ICAO secretariat, will identify suitable scientific experts. This will involve requesting that CAEP Members and observers nominate experts who are appropriately qualified and who conduct research in a subject area relevant to the CAEP/11 work programme.	Membership	SG2016
I.02	Aviation Noise	ISG to conduct a 'Noise Impacts Workshop' and provide an update to the current White Paper under development for CAEP/10 on aviation noise (in conjunction with WG1 & WG2).	WP to CAEP	Draft to SG2018 Final to CAEP/11
I.03	Adaptation	Assist WG2 in the assessment of the current understanding of the risks to aviation from climate change and develop guidance material on the best practices on adaptation.	Report and Guidance material	Draft to SG2018 Final to CAEP/11
I.04	Properties of Engine Black Carbon Emissions	[Led by WG3, ref. Task E.13] As a climate-related activity, ISG will Support WG3 in the provision of estimations for the size and size distribution, density, morphology and internal structure of nvPM and Black Carbon emissions from aircraft engines. Assist WG3 in providing details on the scientific uncertainties associated with the estimates. And support any IE review (e.g. NOx/PM) as appropriate drawing in external expertise.	Report	SG2017
I.05	Aviation and Global Atmosphere update	Contribute to an update to the information.	Plan for SG2016 Report to CAEP/11	Ongoing

CAEP/11 Impacts and Science Group (ISG) Work Programme				
Task Number	Task Title	Task Description	Deliverables	Deliverable Date
I.06	Update to Doc 9889	To provide ad hoc support and advice to WG3 as required in an update of ICAO Doc 9889 to replace emissions technical information that is now out-of-date.	Report	Ongoing
I.07	CBA Scoping	MDG in concert with ISG identify and evaluate tools for including noise, LAQ and GHG impacts (including monetization tools for use as future CAEP assessments).	Report	CAEP/11
I.08	Feasibility of ICAO climate change goals	ISG, AFTF, MDG to scope work for putting international aviation emissions into the context of a 1,000 Gt budget (1.5/2°C scenario).	Scope of work	SG2016

CAEP/11 Alternative Fuels Task Force (AFTF) Work Programme				
Resources offered by: Australia, Brazil, Canada, Italy, Spain, United States, United Arab Emirates, IATA, IBAC, ICCAIA, ICSA				
<i>Note: Meetings of AFTF and GMTF are to be held back-to-back during CAEP/11</i>				
Task Number	Task Title	Task Description	Deliverables	Deliverable Date
S.01	Computation of alternative fuels land use change emissions for use in the GMBM MRV	Over CAEP/11, a follow-on of the AFTF would carry out the computations of induced land use change emissions from alternative fuels for all world regions, for use to report alternative fuels emissions in the GMBM MRV.	List of default values	CAEP/11
S.02	Computation of default values for alternative jet fuel life cycle emissions for use in the GMBM MRV	Over CAEP/11, a follow-on of the AFTF would carry out the computations of “core” LCA default values that could be used by operators to report their emissions from the use alternative fuels. "Core" life cycle emissions designate the emissions from the feedstock production to the tank of the aircraft, land use change emissions being excluded.	List of default values	CAEP/11
S.03	Aviation and Global Atmosphere update	Contribute to an update to the information.	Ongoing support	Ongoing
S.04	Guidance on Potential Policies and Coordinated Approaches for the Deployment of Sustainable Alternative Fuels for Aviation	Outline existing policy instruments incentivizing deployment of sustainable alternative fuels, as well as barriers or disincentive mechanisms grouped in different types or categories with similar characteristics and nature. As a second step, the work provided to the Steering Group should identify “potential policies” which have been demonstrated to be feasible, effective, and practical. Such identification should be done through CAEP assessment based on best practices, lesson learned, and proven positive results from the implementation of those policy instruments, which might include policies developed for other sectors, applicable to air transport. Report on common elements and general recommendations, based on the above assessments and analyses from already implemented policies, to facilitate the implementation of those policies and incentive mechanisms by	Step 1: SG 2016 Step 2: SG 2017 Step 3: SG 2018 Final Report: CAEP/11	CAEP/11

CAEP/11 Alternative Fuels Task Force (AFTF) Work Programme				
Resources offered by: Australia, Brazil, Canada, Italy, Spain, United States, United Arab Emirates, IATA, IBAC, ICCAIA, ICSA				
<i>Note: Meetings of AFTF and GMTF are to be held back-to-back during CAEP/11</i>				
Task Number	Task Title	Task Description	Deliverables	Deliverable Date
		Member States or regions, using effective policy approaches when considered beneficial.		
S.05	Sustainability criteria	The goal is to develop recommendations on sustainability criteria for alternative fuels in the context of the recognition under the Global Market-Based Mechanism (GMBM). The work will be prioritized by developing environmental criteria first, followed by social and economic criteria at a later stage. It is planned to build as much as possible upon existing sustainability standards and frameworks, which will be analysed and compared in order to develop recommendations for CAEP.	Report: SG 2016 Report: SG 2017 Report: SG 2018 Final Report: CAEP/11	CAEP/11
S.06	Roundtable	Secretariat organize a series of roundtable discussion or workshops that would bring the appropriate experts together to further discuss on specific scientific/technical discussions that co-rapporteurs might consider necessary to develop outside the main work stream.	As required	As required
S.07	Feasibility of ICAO climate change goals	ISG, AFTF, MDG to scope work for putting international aviation emissions into the context of a 1,000 Gt budget (1.5/2°C scenario).	Scope of work	SG2016

CAEP/11 Global Market-Based Measure Technical Task Force (GMTF) Work Programme				
Resources offered by : France, Sweden, United Kingdom, United States, Norway, IATA, IBAC, ICCAIA, ICSA				
<i>Note: Meetings of AFTF and GMTF are to be held back-to-back during CAEP/11</i>				
Task Number	Task Title	Task Description	Deliverables	Deliverable Date
G.01	MRV: Accountable Entities	Develop recommendations on how to apply accountable entity declaration process, how to pool accountable entities and how to attribute accountable entities to States.	Additional recommendations on accountable entities declaration process and identification /allocation	SG2016
G.02	MRV: Monitoring Plans	Further assess elements and procedures for implementing emissions monitoring plans and prepare initial guidance.	Additional recommendations on procedures for implementing monitoring plans and initial guidance on procedures and monitoring plan elements	SG2016
G.03	MRV: Monitoring of Fuel Use	Establish uncertainty thresholds for monitoring methods. Analyze thresholds for eligibility to apply Tier 2 monitoring, create steps for implementation of different monitoring methods and analyze block hour fuel methodology.	Recommendations on eligibility thresholds and implementation procedures	SG2016
G.04	MRV: Reporting	Identify and make recommendations on which entities should develop, maintain and update the online tools, the common reporting language and the reporting template. Revise and update of the minimum data set to be reported.	Recommendations for emissions reporting	SG2016
G.05	MRV: Transparency and Confidentiality	Continue work on which data could be made available to different stakeholders, take into account the need for States exchange information as required on MRV related matters.	Recommendations on data transparency	SG2016
G.06	MRV: Verification	Continue the development of specific recommendations and guidance for each step of the pathway, basing these on the relevant ISO standards as appropriate.	Recommendations on verification	SG2016
G.07	MRV: Simplified Compliance Procedures	Create simplified MRV procedures for small emitters. Further analyze eligibility thresholds and simplified emissions estimation methods.	Recommendations for simplified procedures	SG2016
G.08	MRV: Alternative	Finalize technical recommendations on monitoring, reporting and verifying	Recommendations on MRV	SG2016

CAEP/11 Global Market-Based Measure Technical Task Force (GMTF) Work Programme				
Resources offered by : France, Sweden, United Kingdom, United States, Norway, IATA, IBAC, ICCAIA, ICSA				
<i>Note: Meetings of AFTF and GMTF are to be held back-to-back during CAEP/11</i>				
Task Number	Task Title	Task Description	Deliverables	Deliverable Date
	Fuels	emissions from alternative fuels.	procedures for alternative fuels	
G.09	MRV: Administration	Support the continuation of MRV work on other open issues including those related to administration, for example, the compliance cycle, and roles and responsibilities.	Recommendations for other MRV open issues.	Ongoing
G.10	MRV: Implementation	Develop "MRV Implementation Guidance".	Guidance document	SG2016
G.11	EUC: Eligibility Criteria	Review need to revise recommendations in view of outcome of COP-21 in Paris.	Recommendations for eligibility criteria	For GMTF/8 review and SG2016 approval
G.12	EUC: Supply, Demand and Price of Units	Review need to revise assessment in view of outcome of COP-21 in Paris and latest developments in markets. Analyze the feasibility of ICAO's regular monitoring of emissions unit prices that could inform price safeguards (should such measures be included in the design of a global MBM).	Assessment of supply, demand and price of units	For GMTF/8 review and SG2016 approval
G.13	EUC: Work on Early Action	Develop recommendations to support early decision of programmes and potentially project types that meet eligibility criteria. Analyze and recommend options for the duration of applicability of any early decisions on emissions unit programmes and potentially project types eligibility.	Summary report with a list of programmes and potential project types that meet eligibility criteria, and their duration of applicability	SG2016
G.14	Registry: Design Elements	Continuation of the work on registries. Contact registry developers and experts to understand and develop design elements and timing of a registry for the global MBM.	Plan for the practical implementation of the global MBM registry system	SG2016
G.15	Registry: Registry Development	Assess cost and develop technical specifications of the global MBM registry system.	Recommendations for the global MBM registry system	CAEP/11
G.16	MBM Implementation Support	Support Council requests for implementing the global MBM.	Information papers	As required

CAEP/11 Global Market-Based Measure Technical Task Force (GMTF) Work Programme				
Resources offered by : France, Sweden, United Kingdom, United States, Norway, IATA, IBAC, ICCAIA, ICSA				
<i>Note: Meetings of AFTF and GMTF are to be held back-to-back during CAEP/11</i>				
Task Number	Task Title	Task Description	Deliverables	Deliverable Date
G.17	Technical Analysis Support	Support Council requests for addition technical analysis relating to the distribution of obligations. Summarize all analytical work undertaken during the CAEP/10 cycle in a report.	Information papers	As required
G.18	GMTF Glossary	Further refine the GMTF glossary.	Glossary	As required

— END —

ISBN 978-92-9258-064-3



9

789292

580643