

MAY 1987

# Mini-MicroSystems

THE MAGAZINE FOR COMPUTER SYSTEMS INTEGRATION

A CAHNERS PUBLICATION

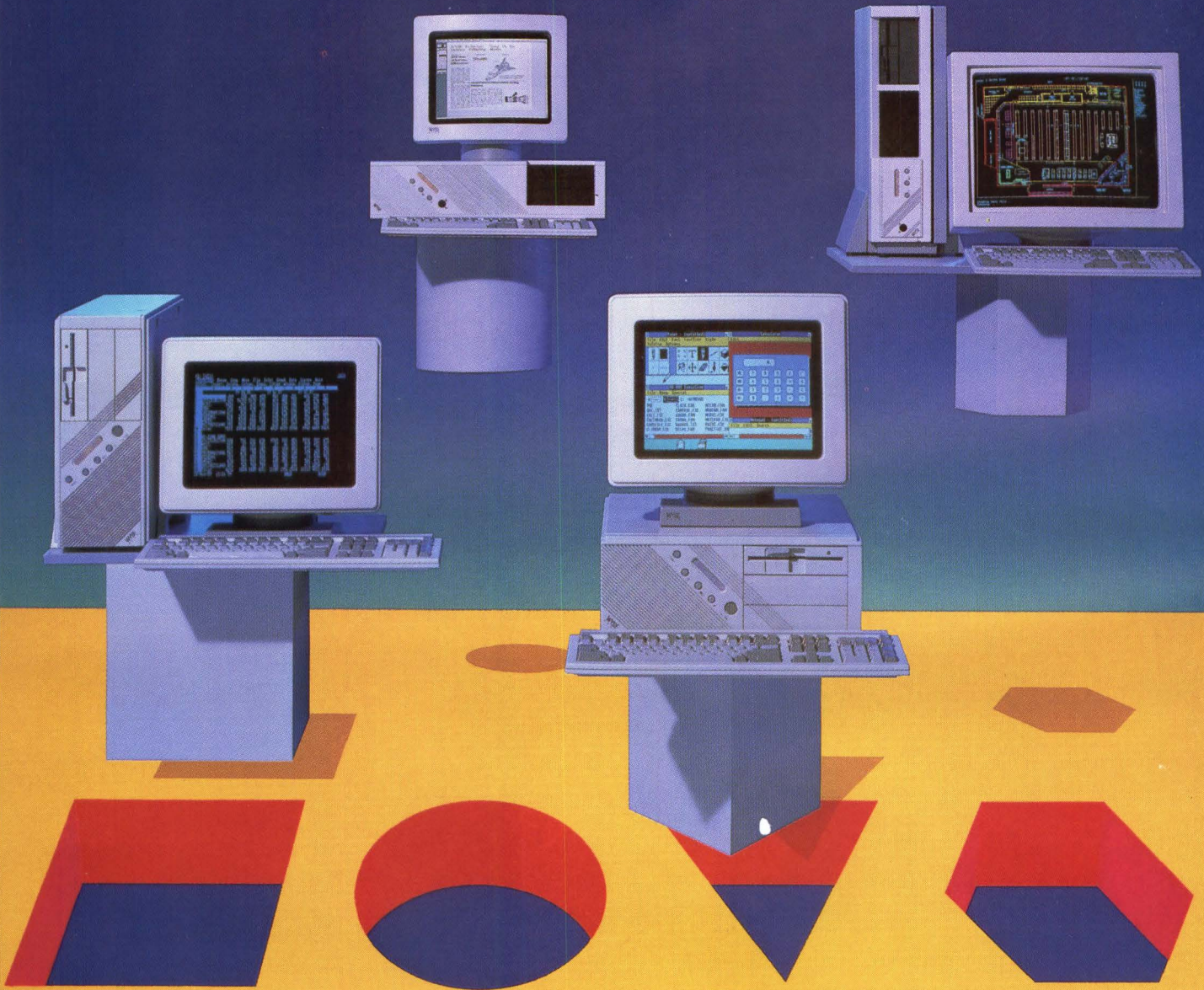

## Passive backplane is active strategy at Wyse

### SPECIAL REPORTS:

- Distributed DBMS
- Database development tool evaluation
- Micro-to-mainframe links
- Multiprocessors

SMARTMODEM 2400

 Hayes®

HS

AA

CD

OH

RD

SD

TR

MR

# CHOOSE THE NAME THAT COMMUNICATES QUALITY.

We'd like to pass along some data on why you should insist on a Hayes Smartmodem 1200™ or Smartmodem 2400.™

First and foremost, no one knows more about building reliable, high performance modems than Hayes. And no wonder. Hayes pioneered the personal computer modem a decade ago, and today is actually the de facto standard in computer communications with the widespread adoption of the Hayes Standard "AT" Command Set.

Second, Hayes has a long-standing and unwavering commitment to customer support, not just to service its products, but to serve as a resource for information, assistance, and technical advice for everyone from the home user to the corporate communications manager. Moreover, Hayes provides more than a warranty on the material and workmanship of its products. Hayes warrants they will perform as promised, as well.

Should you need further data to help you make up your mind, we offer this reassuring statistic: Year after year, more personal computer owners buy far more Hayes modems than any other kind.

And that may be because a Hayes modem is the only modem with the ability to transmit and receive data, and at the same time convey a feeling of peace of mind.

**Hayes**®  
SAY YES TO THE FUTURE

# The Only HP-GL™ Compatible Printer/Plotter from A to C-Size



## JDL-850 EWS™/GL Engineering Workstation Printer/Plotter

**HP-GL compatibility and performance.** The 850 EWS/GL emulates HP-GL protocol to produce high quality drawings from A to C-size in 14 colors, with line quality, accuracy, and speed exceeding most pen plotters. Plotting on paper and vellum up to 18 inches wide you have true unattended operation with no pens to change or run out of ink mid-plot.

**Faster plotting and increased system productivity.** The 850 EWS/GL not only outperforms pen plotters, vector files can be transmitted to the printer/plotter at up to 19.2K baud freeing your system in less than half the time. You gain 100% more productive system time. A copy mode allows you to make up to 99 copies of a plot without re-transmitting the vector file. And an image size control feature lets you fit your drawing to the paper size with reduction or enlargement from 5% to 200%.

**In micro, mini and mainframe applications** the 850 EWS/GL provides high resolution plotting with virtually every CAE/CAD/AEC and graphics software package that supports HP-GL (HP-7475A).

**For high speed text and data applications** the 850 EWS/GL features a 1MB print spooler and speeds of 144 cps in letter quality and 360 cps in draft quality.

Emulating the Diablo 630, IBM 5182 Color Printer and Epson printers, the 850 EWS/GL is compatible with word processing, spreadsheet, project management and business graphics programs.

**HP-GL compatibility, speed, media and output versatility, and desktop size** make the 850 EWS/GL Printer/Plotter the number one performance and price choice for your CAD workstation.

### The JDL-850 EWS Series:

- 850 EWS Printer/Plotter
- 850 EWS/GL (HP-GL compatibility built-in)
- 850 EWS with GL Processor Controller



For specifications and a plot sample call:  
**West: (805) 495-3451**  
**East: (704) 541-6352**

2801 Townsgate Road, Suite 104  
Westlake Village, CA 91361

IBM is a registered trademark of International Business Machines Corp. Diablo is a registered trademark of Xerox Corp. Epson is a registered trademark of Epson America. HP-GL is a registered trademark of Hewlett-Packard Co.

**CIRCLE NO. 2 ON INQUIRY CARD**

NEC WOULD LIKE TO WISH ALL  
ITS DISK DRIVE COMPETITORS  
MANY HAPPY RETURNS.



**NEC guarantees a DOA rate of less than 1%.**

A high DOA rate can take a big chunk out of your bottom line.

After all it takes 15 to 20 minutes to test one drive. And if the drive doesn't work you have to spend even more time repacking it and sending it back. Then you have to sit and wait for a replacement.

NEC can make your life much happier. Just ask and we'll guarantee the lowest DOA rate in the industry—less than 1%. In writing. What you'll likely get from our competitors is 5-10%.

A low DOA rate is just the icing on the cake. NEC disk drives are also more reliable over the long run. In fact, in the average lifetime of any NEC drive, 9 out of 10 will never fail.

NEC has been designing and improving disk drives for over 25 years. Way back in 1959, we were one of the first to create magnetic recording devices. NEC has grown up to be a 13 billion dollar worldwide company. So you can expect continuing products and support.

If other disk drive suppliers keep sending you surprises instead of drives that work right out of the box, call in NEC. You can reach us at 1-800-343-4418. (In Massachusetts call 617-264-8635.) Or write NEC Information Systems, Inc., 1414 Massachusetts Avenue, Department 1610, Boxborough, MA 01719.



**NEC DISK DRIVES.  
RELIABILITY RUNS IN THE FAMILY.**

**NEC**

NEC Information Systems, Inc.

**C&C** Computers and Communications

**CIRCLE NO. 3 ON INQUIRY CARD**

Hard Copy  
VS.

Easy Copy

Easy Copy

Easy Copy

Easy Copy

Easy Copy

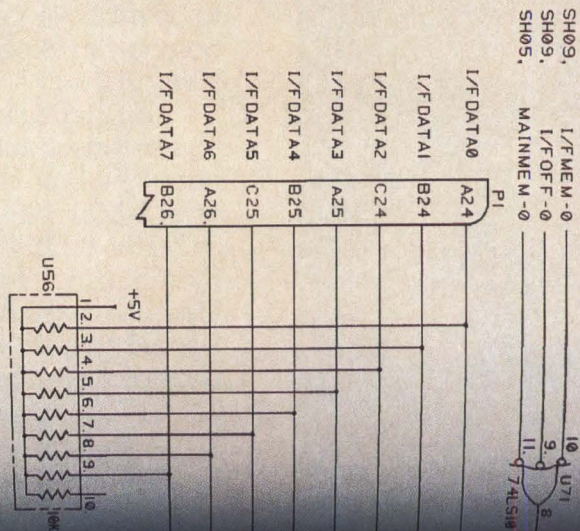

The Honeywell Visigraph printer/plotter offers easy interface setup and page formatting, as well as:

- Programmable video interface (up to 1280 x 1024, 60 Hz noninterlaced)
- 8-bit parallel interface (V-80)
- A, B, A3 and A4 size drawings
- 300 dpi monochrome thermal transfer printing
- Fast plots (8.5 second A size)
- Lightweight compact construction
- Built-in

self-test • Simple, clean loading • Prices starting from \$7,950 • Attractive OEM terms

Contact Dan Winter for more information.  
Honeywell Test Instruments Division  
Box 5227, Denver, CO 80217-5227  
(303) 773-4745

**Special Offer Extended**  
Trade in your Versatec\* V-80 and receive  
\$1000 off a Honeywell Visigraph.

**VISIGRAPH**

Honeywell

Together, we can find the answers.

**Honeywell**

\*Versatec is a trademark of Versatec, Inc.

CIRCLE NO. 4 ON INQUIRY CARD

©1987 Honeywell Test Instruments Division

# Mini-Micro Systems

A CAHNERS PUBLICATION

VOL. XX NO. 5  
MAY 1987

## PRODUCT SPOTLIGHT

### COVER STORY

**Passive backplane proves active strategy at Wyse** ..... 29

**Pyramid's RISC-based superminis afford a multiprocessor approach** ..... 45

**IBM's Personal System / 2** ..... 47

## INTERPRETER

### NETWORKS

**System integrators jump into network management** ..... 48

### MEMORY TECHNOLOGY

**Bubble memory bursts into niche markets** ..... 55

## FEATURES

**Feature Highlights** ..... 61

**True distributed DBMSes presage big dividends** ..... 65

Despite their slow emergence, varied types of distributed database management systems promise to help integrate heterogeneous computing environments

**Database development tools: an evaluation** ..... 77

An independent company evaluates over 50 database development tools is available for applications developers, software houses and end users.

**LANs link PCs to mainframes** ..... 91

Local-area-network gateways to IBM SNA systems challenge conventional 3270 emulators, and LU 6.2 products threaten to rattle the micro-to-mainframe arena.

**Multiprocessors boost system power** ..... 105

By often outperforming uniprocessor minicomputers, multiprocessors can bolster OEMs and system integrators against traditional market giants.

### DEC DIRECTIONS

**Graphical interface speeds VAX programming** ..... 121

Use of a graphics-based user interface, called "Picture Programming," and an application generator accelerates software production for VAXes.

**SPRING PERIPHERALS HANDBOOK** . . . Table of Contents ..... 147

## DEPARTMENTS

Editorial Staff ..... 6 New Products ..... 131

Editorial ..... 9 Software Review ..... 145

Letters ..... 12 Index to Advertisers ..... 172

Breakpoints ..... 17 Mini-Micro Marketplace ..... 174

Cahners Publishing Company • A Division of Reed Publishing USA • Specialized Business Magazines for Building and Construction • Computer/Technology • Electronics • Food/Packaging • Manufacturing Industries • Medical, Design & Publishing  
**MINI-MICRO SYSTEMS®** (ISSN 0364-9342) is published monthly with additional issues in May and November by Cahners Publishing Company, A Division of Reed Publishing USA, 275 Washington St., Newton, MA 02158. William M. Platt, President; Terrence M. McDermott, Executive Vice President; Jerry D. Neth, Vice President of Publishing Operations; J.J. Walsh, Financial Vice President/Magazine Division; Thomas J. Dellamaria, Vice President Production and Manufacturing; Frank Sibley, Group Vice President. Copyright 1987 by Reed Publishing USA, a division of Reed Holdings Inc., Saul Goldweitz, Chairman; Ronald G. Segel, President and Chief Executive Officer, Robert L. Krakoff, Executive Vice President. Circulation records are maintained at Cahners Publishing Co., 270 St. Paul St., Denver, CO 80206. Second class postage paid at Denver, CO 80202 and additional mailing offices. Postmaster: Send address changes to MINI-MICRO SYSTEMS®, 270 St. Paul St., Denver, CO 80206. MINI-MICRO SYSTEMS® is circulated without charge by name and title to U.S.- and Western European-based corporate and technical management, systems engineers and other personnel who meet qualification procedures. Available to others at the rate of \$65 per year in the United States; \$80 in Canada and Mexico; \$105 surface mail in all other countries; air mail surcharge, \$45 (14 issues). Special HANDBOOK issues, \$15. Single issues, \$6 in the United States; \$8 in Canada and Mexico; \$10 in all other countries.

© 1987 by Cahners Publishing Company, Division of Reed Publishing USA. All rights reserved.



p. 29 . . . Wyse introduces "modular system architecture." Art design by Blankenship-Tavares Inc. Courtesy of Wyse Technology.

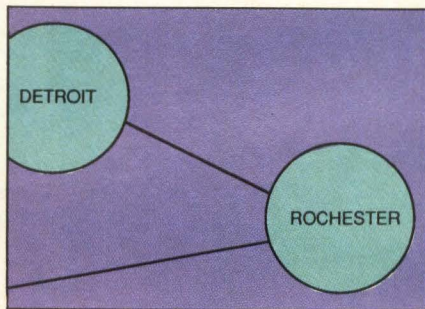

p. 65 . . . . . Integrating environments

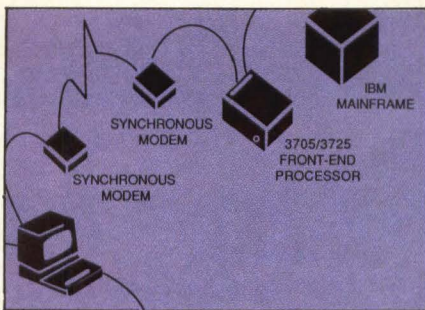

p. 91 . . . Linking PCs to mainframes

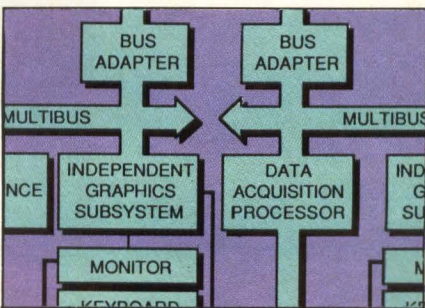

p. 105 . . . . . Battling the giants

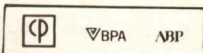



## Systems Integration Profits: Beyond LAN's End.



*Getting ahead in today's value added reseller market means providing your customers with connectivity solutions between hardware and operating systems. CYB Systems' UNITE™ gives you an unprecedented advantage that can put you on the road to higher profits in the burgeoning systems integration market.*

*UNITE's unique connective power goes beyond networking, boosting the productive power of PC stations, departments and work groups with its ability to move data between disparate operating systems and machines.*

*With UNITE you can deliver integrated control over MS™ DOS, PC DOS and UNIX™ operating environments—regardless of vendor, and provide an on-board upward link to popular mainframes via TCP/IP or SNA protocols.*

*And UNITE is fully adaptable to greater interconnective capabilities further up the road.*

*CYB Systems' UNITE. The sign of the times for systems integration. To find out how UNITE can help your clients and enhance your business, call or write CYB Systems, or visit our suite at the Dallas INFOMART.*



**CYB SYSTEMS, INC.**  
INFOMART, Suite 2017  
1950 Stemmons Freeway  
Dallas, Texas 75207  
214/746-5390

UNITE is a trademark of CYB Systems, Inc. MS- is a trademark of Microsoft Corporation.  
UNIX is a trademark of Bell Laboratories.

**CIRCLE NO. 5 ON INQUIRY CARD**

### STAFF

Vice President/Publisher  
**Donald Fagan**

Chief Editor  
**George V. Kotelly**

Executive Editor  
**Tim Mead**

Managing Editor  
**James F. Donohue**

Senior Editor: **David Simpson**  
Irvine, (714) 851-9422  
Senior Editor: **Mike Seither**  
San Jose, (408) 296-0868

Senior Editor: **Doug Pryor**  
Senior Editor: **Tim Scannell**

Associate Editor/Research: **Frances Michalski**  
Staff Editor/New Products: **Megan Niels**  
Editorial Assistant: **Lisa Kramer**

#### Contributing Editors

**Andrew Allison**  
Mini/Micro Computer  
Product and Market Consultant  
**Raymond C. Freeman Jr.**  
Freeman Associates  
Special Features Editor: **Wendy Rauch-Hindin**  
Dix Hills, N.Y.  
(516) 667-7278  
**Gene R. Talsky**  
Professional Marketing Management Inc.  
**Edward Teja**  
Freehold Corp.

#### Editorial Production

Chief Production Editor: **Arsene C. Davignon**  
Staff Editor/Production: **Mary Anne Weeks**

#### Editorial Services

**Terri Gellegos**

Assistant to the Publisher: **Linda L. Lovett**

#### Art Staff

Art Director: **Cynthia Norton**  
Director of Art Dept.: **Norm Graf**  
Senior Art Director: **Mary Anne Ganley**

#### Production Staff

VP Production: **Wayne Hulitzky**  
Director/Production: **John Sanders**  
Supervisor: **William Tomaselli**  
Production Manager: **Betsy Cooper**  
Composition: **Diane Malone**

#### Editorial Offices

**Boston:** 275 Washington St., Newton, MA 02158, (617) 964-3030. **Irvine:** 18818 Teller Ave., Suite 170, Irvine, CA 92715. **Los Angeles:** 12233 W. Olympic Blvd., Los Angeles, CA 90064. **San Jose:** 3031 Tisch Way, San Jose, CA 95128.

**Reprints** of Mini-Micro Systems articles are available on a custom printing basis at reasonable prices in quantities of 500 or more. For an exact quote, contact Katie Pyziak, Cahners Reprint Service, Cahners Plaza, 1350 E. Touhy Ave., Box 5080, Des Plaines, IL 60018. Phone (312)635-8800.



# The wait is over. You can evaluate this 1/2" cartridge tape drive today.

## Fujitsu delivers products, not just promises.

It's here—a high-performance 1/2" cartridge tape drive, in a 5 1/4" form factor.

Fujitsu America has it. We're ready today with evaluation units. And we have a product that performs.

Our M2451A cartridge tape drive gives you up to 120 MB of formatted storage capacity. It runs in both streaming and start/stop modes, at streaming speeds of 75 and 50 ips, so it fits almost any application. Its ESDI interface assures easy, cost-effective system integration.

And for your SCSI system, the optional high-performance M1008A SCSI controller is now available.

Most importantly, these cartridge tape drives are already proven and working in systems today. And with second sources available for both drives and media, you can be sure of protecting your investment in this technology.

For more information about Fujitsu's 1/2" cartridge, or other tape drives, call (408) 946-8777. Or write Fujitsu America, Inc., Storage Products Division, 3055 Orchard Drive, San Jose, CA 95134-2017.

Fujitsu tape drives meet the quality standards and technical requirements that have made this one of the world's leading companies. That's leadership you can depend on to develop the technology you need. And deliver it.

**CIRCLE NO. 6 ON INQUIRY CARD**

**We're developing technology for you.**



**FUJITSU AMERICA**

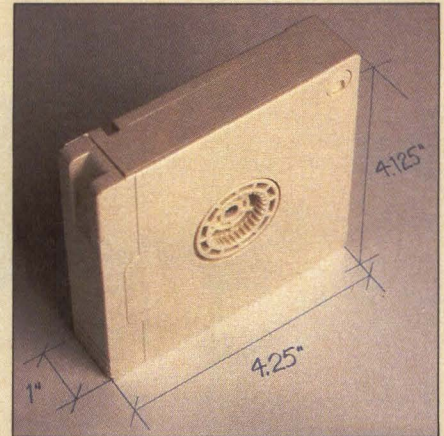

For data integrity and ease of use, fully enclosed 1/2" media is packed in a single reel, in a compact plastic enclosure.

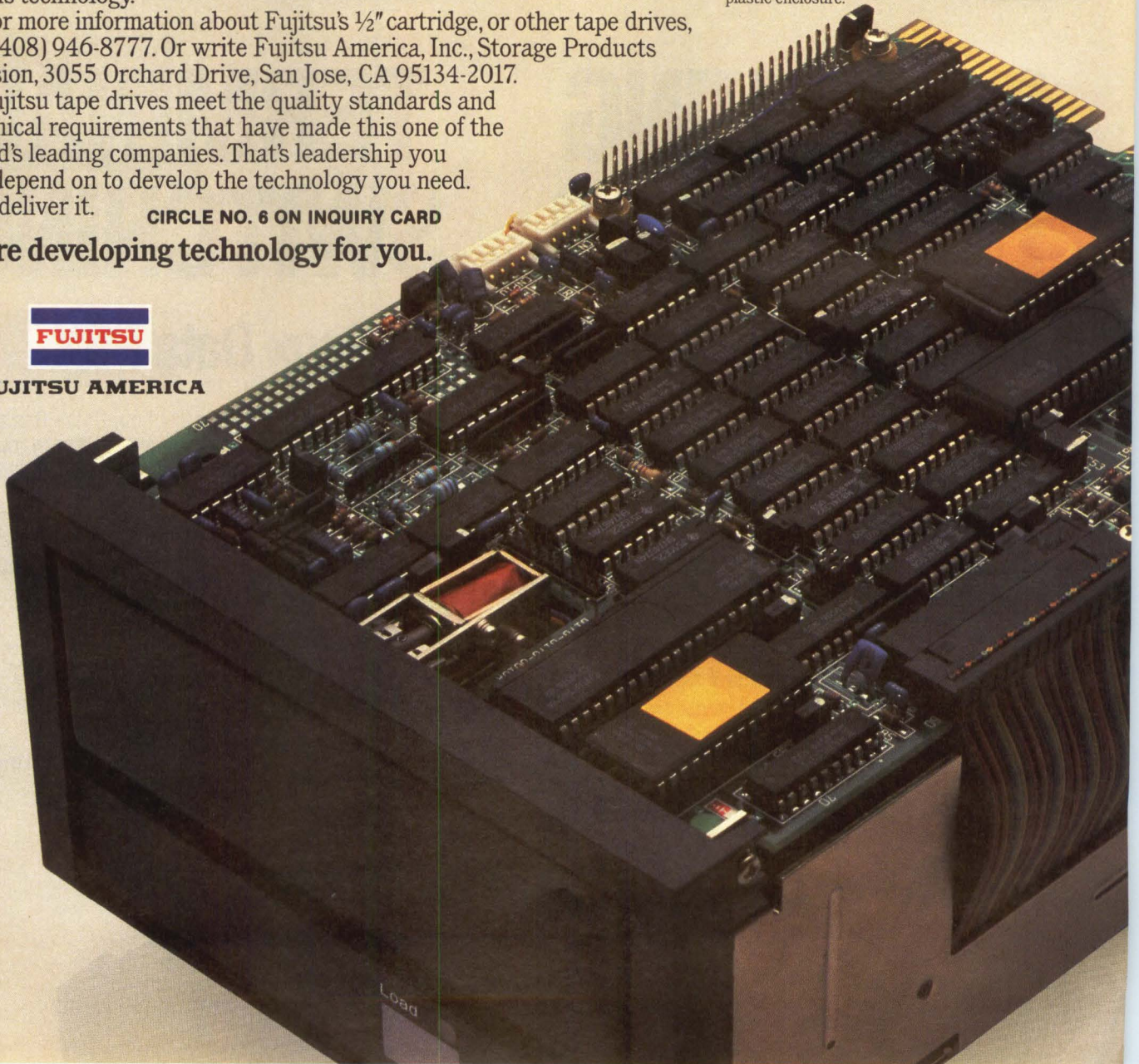

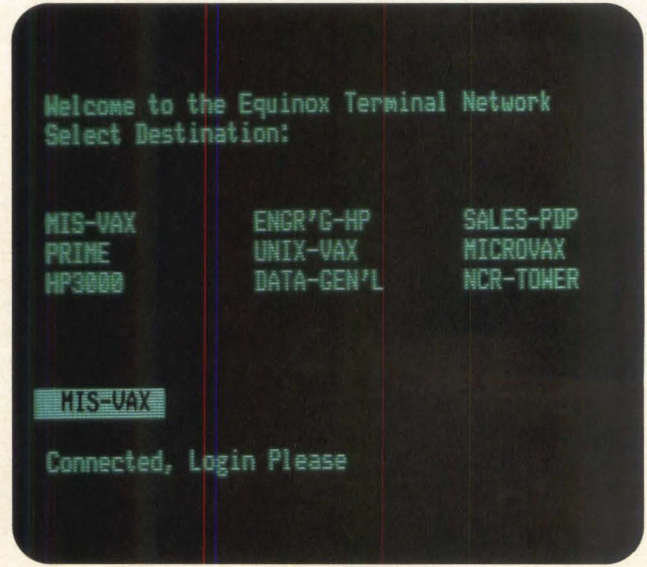

# SWITCHING TERMINALS.

# TERMINAL SWITCHING.

## Get Connected With An Equinox Data PBX.

An Equinox Terminal Network lets you connect your terminal to any async RS-232 computer, modem or printer with a few keystrokes. No more cable swapping, A-B switches or moving between terminals.

### Low-Cost, Easy Installation.

Equinox terminal networks cost under \$100 per connection and are protocol transparent. "Plug and play" wiring accessories, menu-driven configuration and on-line "HELP" make installation a snap.

### Network Growth With Compatible Products.

Whether you have a few terminals or thousands, we have a Data PBX to create the right size Terminal

Network for your needs. And all of our Data PBXs are fully compatible, so they can be expanded and networked to accommodate growth and protect your investment.

Find out why thousands of terminal users rely on an Equinox Data PBX for terminal networking. For more information, an on-site demonstration or to find out about our 30-day no-risk free trial program,

### Call 1-800-DATA-PBX.

In Florida call (305)255-3500.

Equinox Systems Inc.  
12041 S.W. 144th Street  
Miami, FL 33186-6108.

Equinox is a registered trademark of Equinox Systems Inc.

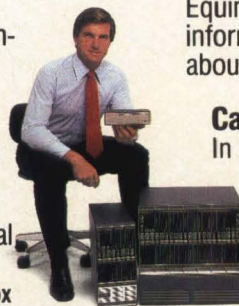

MDX  
8-16 Lines

DS-5  
24-960 Lines

DS-15  
24-1320 Lines

# EQUINOX

## Smart Connections For Dumb Terminals.

CIRCLE NO. 7 ON INQUIRY CARD

# EDITORIAL

## R&D: A MANDATORY INVESTMENT

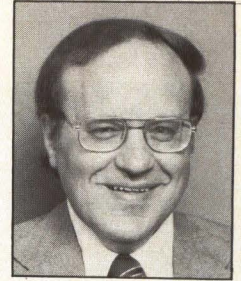

Research and development (R&D) has attained new meaning this year as computer companies search for new technology and products to improve their competitive edge—and, just maybe, ensure their sheer survival. To combat the influx of foreign competition that burst onto the computer scene in 1986, U.S. companies are closely examining their R&D programs to make sure that they hold the promise of innovative, useful and quality products.

To support R&D, U.S. industrial research spending has steadily increased over the past decade at a robust 13 percent average each year. In 1987, though, R&D budgets will drop, say two recent surveys. In one, Battelle Memorial Institute, Columbus, Ohio, estimates an increase in R&D spending of only 7.2 percent. In the other, the National Science Foundation forecasts a rise of just 5 percent.

Both studies conclude that the dollar downturn results from inaccurate sales projections, concern over short-term profits and budget slashes due to corporate mergers and acquisitions. To overcome these financial problems, many companies have opted to drastically reduce their long-term R&D efforts.

In 1986, private industry accounted for 50 percent of the estimated \$116 billion in R&D expenditures. The government spent about 47 percent of these dollars; the remaining funds were doled out by universities and non-profit institutions.

In obtaining R&D services computer companies have relearned the merits of working with the academic community.

A prime example of advanced technology transfers from campus laboratories to industrial centers involves the CMU Robotics institute at Carnegie-Mellon University. Described as the world's largest industry-financed center for research on robots, the Institute serves some 30 companies with progressive technical information. These companies contribute heavily to cover the Institute's \$7.2 million annual budget. But, in return, they gain the skills of about 200 scientific and engineering

experts in artificial intelligence, computer vision and robotics.

Even with this renewed company-college collaboration, some age-old problems still persist. For example, college professors are eternally vigilant against industry corrupting the pure-research and teaching processes. And companies constantly worry that basic research will absorb precious short-term funds and might not mature into practical products and profits.

More important, though, universities appear eager to participate in R&D partnerships. For one key reason, they must rebuild their outdated scientific facilities. *Business Week* estimates that about 240 of the United States' 290 engineering schools are operating with outmoded equipment, and that more than \$30 billion is needed to refurbish these facilities.

In addition, many teaching professors at important scientific schools have not kept pace with technology. What's more, the number of graduate engineering and scientific students has decreased markedly over the past few years.

Fortunately, help is on the way. For one thing, the federal government is issuing equipment grants to universities to the tune of \$50 million this year. For another, computer companies are also donating millions of dollars in new systems.

Industry analysts agree unanimously that cooperative R&D ventures are necessary to maintain U.S. supremacy in the computer industry. And the company-college link must be strengthened even further. For its part, the computer industry must resolutely increase its investment in R&D programs. The industry's survival depends on it.

A handwritten signature in cursive script that reads "George V. Kotlly".

George V. Kotlly  
Chief Editor



# THE INSIGHT



# AND THE DRIVE.

## FIRST THE 40MB DRIVE, NOW THE 100MB INSIGHT.

Now your next 16 and 32-bit downsized system can compete utilizing 40 and 100 megabytes of high-performance 3½-inch hard disk storage. Only Conner Peripherals gives you the optimum size drive and performance insight required for the next generation of portables, desktops and workstations.

Our CP340, 40MB (formatted), is shipping now in America's hottest new compact portable and desktop computers. And our new CP3100, 100MB (formatted), is available now for evaluation.

Both drives provide higher reliability with defect management. Each offers higher performance with fast average access—CP3100 at 25 msec and CP340 at 29. They are more durable, handling shock to 75G and dissipate only 7 watts of power.

Improve your system with true high-performance features like data buffering, rotary voice coil actuator, embedded servo and integrated intelligent controller with SCSI interface. Plus the lowest cost per megabyte.

No one else is shipping high-performance 3½-inch disk drives like these. Only Conner Peripherals has—the insight and the drive—to give you the competitive edge now!

Call today for more insight and the drives.

**CONNER**  
PERIPHERALS

 THE INSIGHT  
AND THE DRIVE.

CIRCLE NO. 8 ON INQUIRY CARD

Conner Peripherals, Inc., 2221 Old Oakland Rd.,  
San Jose, CA 95131, Telephone (408) 433-3340,  
Boston (617) 660-1088,  
United Kingdom (44) 322-330-333.  
©1987 Conner Peripherals, Inc.

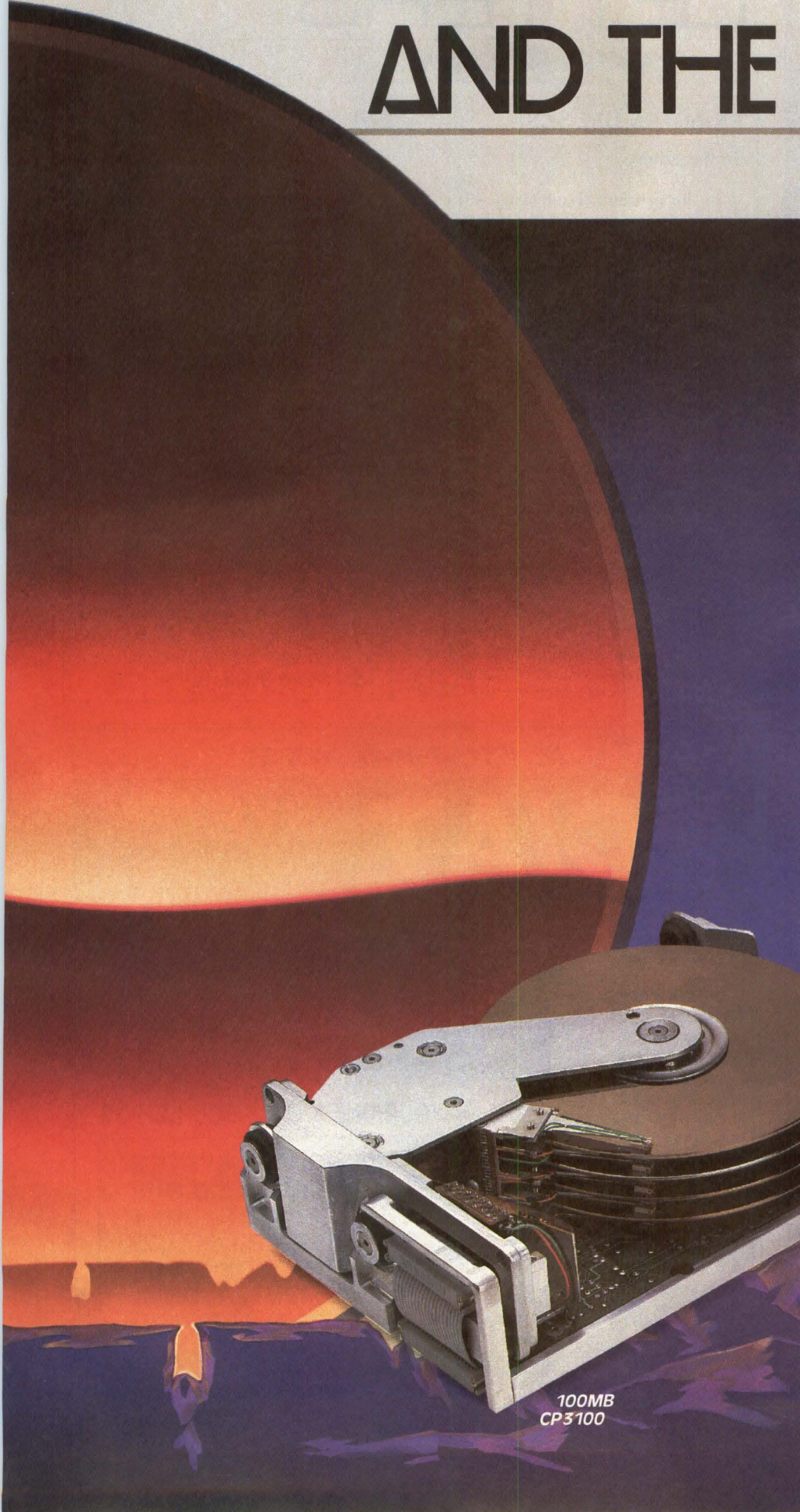

100MB  
CP3100

# VMEbus MULTIBUS IBM-RT PC MEMORY

## VME

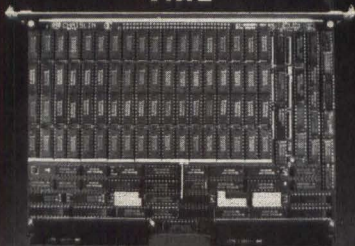

### CI-VMEemory

- 4MB, 8MB, 16MB in one VMEbus slot
- VME Revision C compatibility
- On board Control Status Register
- Future Upgradeable to 64MB

## MULTIBUS



### CI-796-EDC

- 128KB to 2 MEGABYTES on one board
- Single bit error correction, double bit error detection
- Selectable in 16K byte increments

## IBM-RT PC

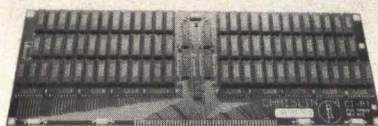

### CI-RT-PC MEMORY

- IBM-RT PC compatible memory board
- Standard configuration of 8 megabytes
- Fast Cycle Times of 170 nanoseconds
- Error Detection and Correction for added reliability

"STATE-OF-THE-ART MEMORIES  
for Qbus, MICROvax, and the VAX"

**Chrislin  
Industries**

Call Toll Free: **800-468-0736** (est.)

31352 VIA COLINAS, WESTLAKE VILLAGE, CA 91362  
TEL: 818-991-2254 TWX 910-494-1253

P.O. BOX 1657 SAN JUAN, PR 00629  
TEL: 809-876-5205 TELEX 345-4170 (CHRISLN PD)

MULTIBUS is a trademark of Intel Corp.  
VAX, MICROVAX, QBUS are trademarks or Digital Equipment Corp.  
IBM is a trademark of International Business Machines.

CIRCLE NO. 9 ON INQUIRY CARD

# LETTERS

## PRINTERS USE SCSI

To the editor:

In the February issue (Page 49) is an article on the small computer systems interface entitled "SCSI extends beyond data storage devices." It seems to raise the question, "Will printers use SCSI?"

Printers already use SCSI and NCR [Corp.] offers that product. Our NCR ADP-60 is a SCSI-to-Dataproducts type of long-line printer-interface adapter that allows one or more hosts to share one or two high-speed printers. The baud rates are printer-dependent, but this controller can operate two 2,000-line-per-minute printers simultaneously. NCR is also considering the development of a low-cost SCSI-to-Centronics type of interface.

In our opinion, printer manufacturers will follow the lead of disk and tape manufacturers in providing embedded SCSI ability within the printer. Value-added manufacturers and system integrators will use bridge-type printer interfaces, such as the NCR

ADP-60.

SCSI printer commands allow the sharing of printer resources by more than one host. The command also allows a SCSI copy operation (such as disk to printer) to be managed by the printer, thus freeing the host from managing this operation.

The SCSI bus can provide the bandwidth necessary to accommodate the non-impact printer marketplace. Printer manufacturers are probably looking at this as the interface of choice.

**John Ast**  
OEM Products Marketing Manager  
NCR Corp. OEM Division  
Wichita, Kan. 67226

## FORGET SOMETHING?

Did you forget to fill out the requalification card attached to the front cover? If you did, please turn back, fill it out and mail it to us right away so you will be sure to keep your free subscription to Mini-Micro Systems.

# NEW A COMPLETE . . . PCIAT SYSTEM ON A CARD

- 80286 PROCESSOR
- 80287 CO-PROCESSOR (Optional)
- 640K RAM
- FLOPPY DISK CONTROLLER
- SCSI (WINCHESTER CTL)
- CGA/HERCULES/MONO
- 2-SERIAL PORTS
- 1-PARALLEL PORT
- KEY BOARD PORT
- SPEAKER & RESET
- REAL TIME CLOCK / CAL.
- PHOENIX BIOS
- 8 or 10 MHz OPERATION

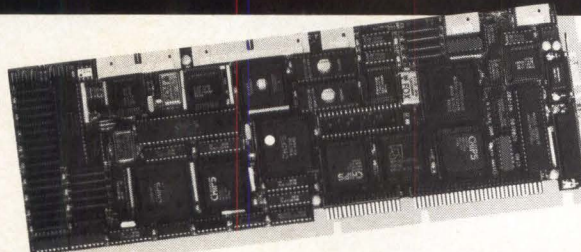

YOUR ONE & ONLY SOURCE FOR

A COMPLETE SYSTEM  
ON A SINGLE BOARD!  
THIS IS NOT JUST  
ANOTHER CPU BOARD  
— BUT A POWERFUL  
/AT COMPUTER ON A  
SINGLE 13.1 x 4.6 BOARD

CALL

**1-800-443-2667**

MS 601-856-4121



**Diversified Technology**

5500 OAKBROOK PKY. SUITE 910 • NORCROSS, GA 30093

MANUFACTURED  
IN THE USA

CIRCLE NO. 29 ON INQUIRY CARD

AN OUNCE OF PREVENTION,  
WITH A POUND OF CURE....

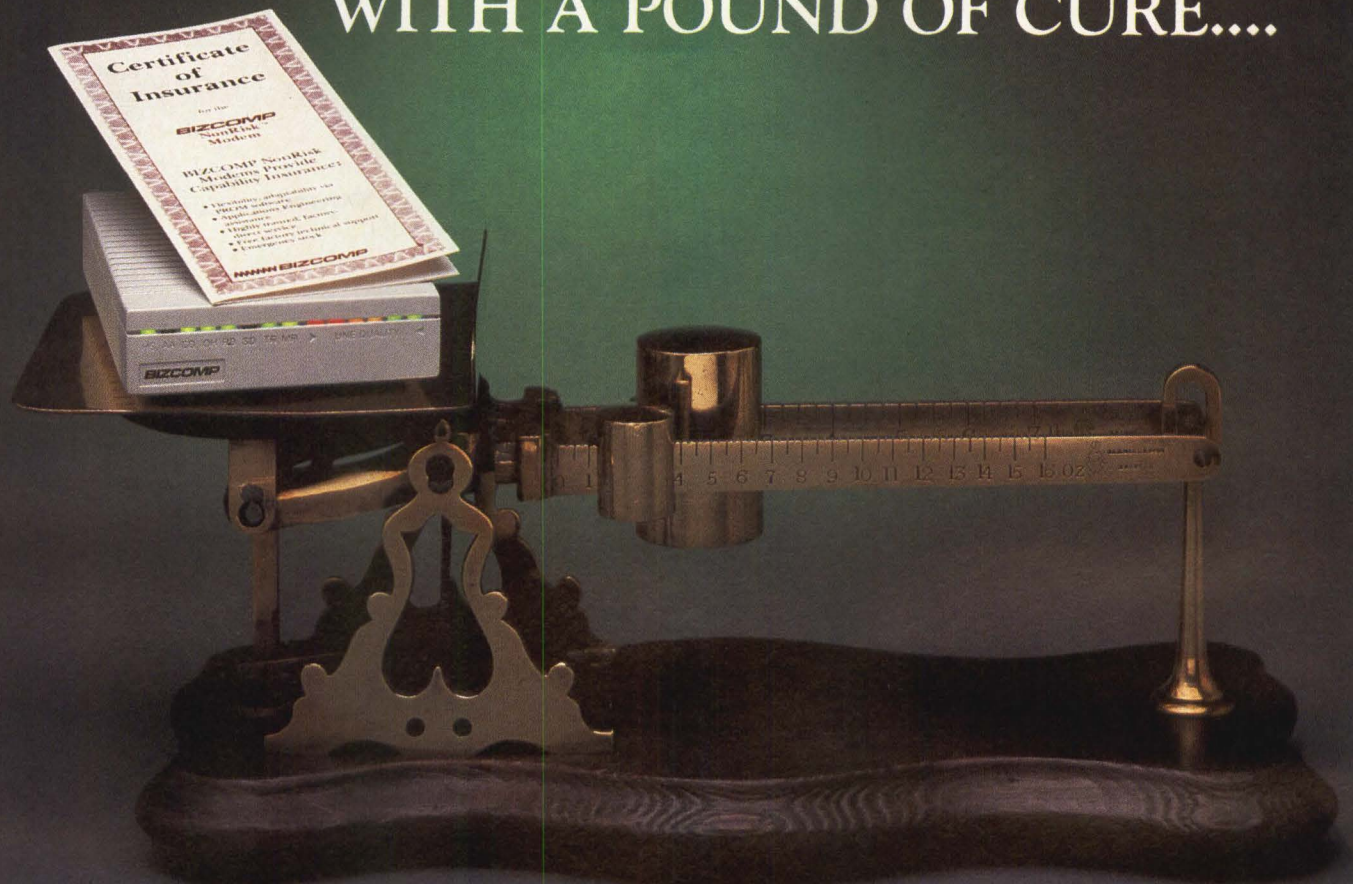

### The NonRisk™ 2400

One Pound, One Ounce. Together, they add up to one of the industry's most heavily weighted values. The NonRisk™ 2400 provides an ounce of prevention for your investment, with a pound of cure for your data connection.

Bizcomp safeguards your modem investment from changing standards and compatibility problems. Packaged with every NonRisk 2400 is our five point insurance policy. One of the major benefits of our coverage plan is your own NonRisk Agent, who is dedicated to solving your datacom needs.

Unlike commodity modems that have "Frozen" their design into silicon chips, The NonRisk 2400 is flexible and adaptable via PROM Software. In addition, we've innovated a new technology that provides up to a 1000 times performance improvement over noisy and weak data connections: AEC™ (Adaptive Echo Cancellation) Technology.

In total, the NonRisk 2400 is designed to outweigh its competition in performance, reliability, and flexibility. You'll get a solid investment without a hefty price tag.

For complete details on the NonRisk 2400 call anytime 800/422-9010 ext. 4048. Or for immediate applications assistance call 408/733-7800.

~~~~~**BIZCOMP**~~~~~

CIRCLE NO. 10 ON INQUIRY CARD

The NonRisk™ Modem Company

© BIZCOMP 1987 NonRisk and AEC are trademarks of Bizcomp Corporation BIZCOMP Corporation, 532 Mercury Drive, Sunnyvale, CA 94086

*Over 350 products  
from over 150  
Suppliers!*

# The SCSI Source Guide

Finally, a comprehensive SCSI reference book for engineers, product planners and marketing personnel who have a need to know:

- What SCSI products are available
- Who supplies SCSI products
- What each SCSI product does
- What level of SCSI functionality each product supports

Published in the Spring and Fall by Technology Forums — the company who also brings you the SCSI Forum and the SCSI Market Study — The SCSI Source Guide includes the following SCSI product categories:

- Chips
- Boards
- Intelligent Peripherals
- Subsystems
- Test Equipment
- Software

Each SCSI Product listing will include:

- Product Category
- Supplier
- Price
- Description
- Supplier ID
- SCSI Support Level

Additionally, information on SCSI suppliers will provide:

- Addresses, phone numbers, and technical contacts
- Cross references to their listed SCSI products

Examples of product listings for intelligent disk drives are found on the reverse side of this data sheet (Courtesy of Seagate and Micropolis).

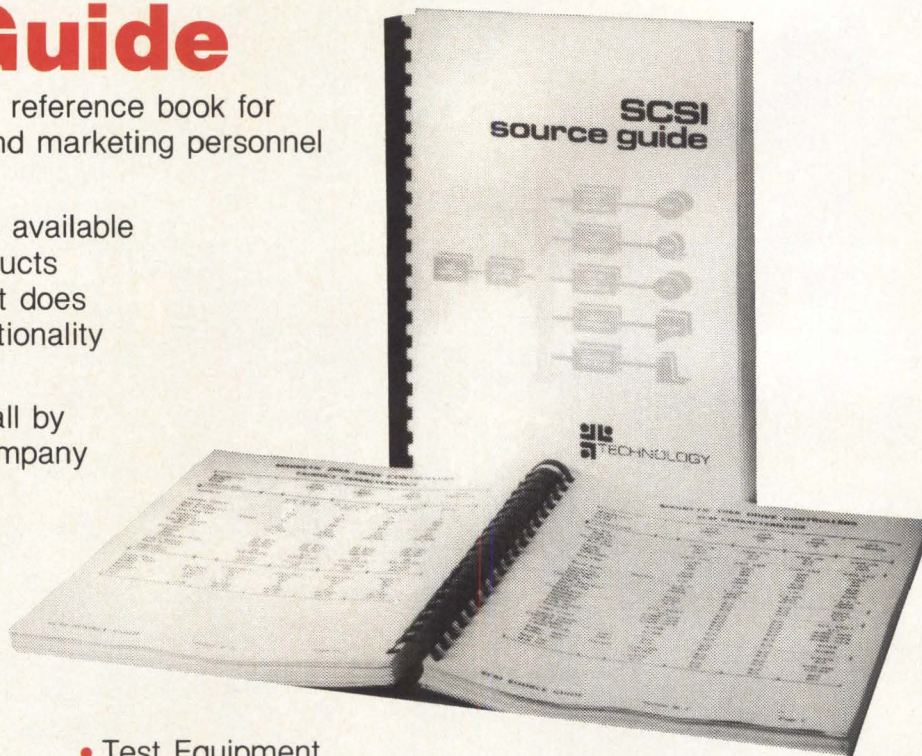

- 
- Please send me a copy of the SCSI Source Guide.
- My check for \$295 is enclosed.
- Bill me. (Net 30 days. Foreign orders must be pre-paid) • No Refunds
- I want my company and its SCSI products to be listed in the SCSI Source Guide. Please send me an SCSI Product Survey.

NAME \_\_\_\_\_

TITLE \_\_\_\_\_ PHONE (\_\_\_\_) \_\_\_\_\_

COMPANY \_\_\_\_\_

ADDRESS \_\_\_\_\_

PLEASE MAIL TO: **TECHNOLOGY FORUMS** • P.O. Box 1729 • Minnetonka, MN 55345 • (612) 934-1415



# GIGABYTES WITHOUT PAYING "GIGABUCKS"!



**DD-8001**  
1.5 Gigabyte  
Subsystem.

Organic Dye,  
Long-Life  
Optical Disk  
Media.

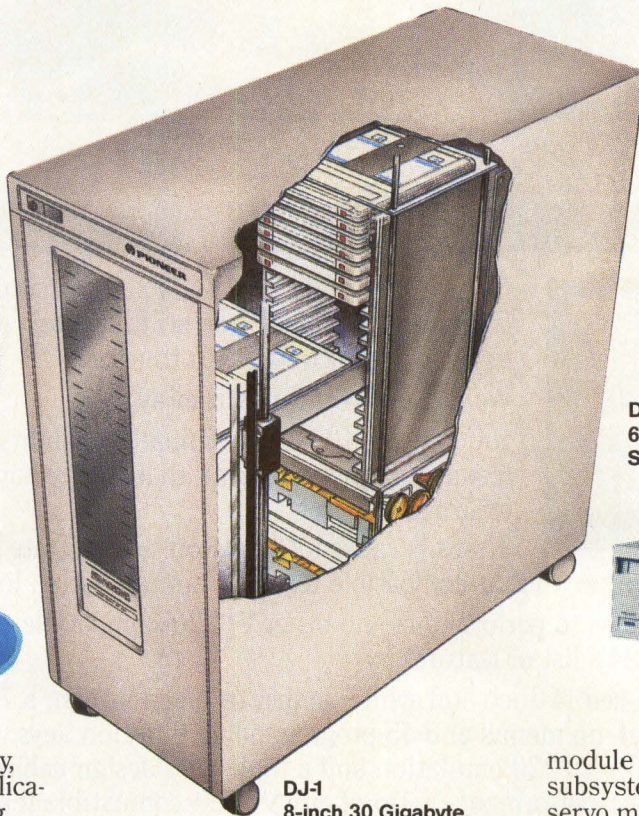

**DJ-1**  
8-inch 30 Gigabyte,  
Optical Disk, Dual-Drive  
Jukebox Autochanger.



**DD-S5001**  
600 Megabyte  
Subsystem.

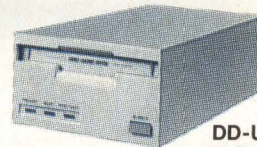

**DD-U5001**  
Full-Height  
"PC" Optical  
Disk Drive.

Advanced Pioneer technology, along with the world's first application of an organic dye recording media make possible the introduction of a new series of highly efficient, low cost, write once (W.O.R.M.) optical disk subsystems from the leader in optical technology... Pioneer.

Featured in this new product line is Pioneer's DJ-1 eight-inch Optical Disk Dual Drive Autochanger Jukebox. This high-speed optical disk jukebox provides for up to 30 gigabytes of data storage capacity (20 two-sided removable cartridges) with an End-User price of \$40,000 per unit... **that's less than a \$1.35 per megabyte of storage capacity.**

The 8-inch drive which is incorporated in the autochanger, is also available in a stand-alone configuration. The DD-8001 eight-inch

stand-alone subsystem combined with the DC-801/DC-802 optical disk media represents the ideal, compact disk drive. (1.5 gigabytes on two sides). The DD-8001 is equipped with the SCSI high-speed parallel computer interface and is available with MS-DOS operating software. With an End-User price of \$13,000 per unit, this front-loading, high-speed drive is ideal for any type of desk top system configuration.

In addition to this outstanding 8-inch technology, Pioneer is also pleased to introduce the DD-U5001 stand-alone and DD-S5001 "PC"

module 5.25-inch optical disk drive subsystems. A new, light-weight servo mechanism developed by Pioneer provides incredibly quick random access to any information on the disk. At an End-User price of between \$2,800 (DD-U5001) to \$3,500 (DD-S5001), the 5.25-inch subsystems are provided with the SCSI interface and full MS-DOS operating software will be available. Each double-sided DC-502 optical disk offers 600 megabytes of storage capacity (300 megabytes per side).

Pioneer's unique 8-inch and 5.25-inch low cost organic dye optical disk media ensure a data storage life of greater than 15 years.

Pioneer is recognized as a world leader in the research, development and manufacturing of optical products and systems.

**PIONEER LaserMemory™**

For more information, contact Pioneer Communications of America, Inc., Optical Memory Products Division, 1058 East 230th Street, Carson, California 90745, (213) 513-1016.

Please join us at Comdex-Spring, Booth 3026 and at NCC, Booth 5408/5410.

CIRCLE NO. 11 ON INQUIRY CARD



Once you've bought our CIT224 alphanumeric VT220-compatible terminal, you still have one more decision to make: What to do with the box.

We suggest you throw it away.

You see, the CIT224 terminal's reliability is so good, it makes no sense worrying that it may have to be returned.

That's because its "dead-on-arrival" rate is less than 1%.

And there's no other VT220-compatible terminal around with a lower DOA rate. And when it comes to performance, no other VT220-compatible terminal stacks up to the CIT224's list of features.

Like an easy-to-see 14-inch soft white, amber or green screen, a 7 x 15 character matrix, 11 set-up menus and 45 programmable function keys. Couple this with proven 100% VT220 emulation and a high-tech design cabinet, and you've got the best price-performance ratio of any VT220-compatible terminal on the market.

Improve your bottom line with the CIT224 terminal. And throw away the box.

For more information on the CIT224, contact CIE Terminals, a C.Itoh company, 2505 McCabe Way, Irvine, CA 92714; or call (714) 660-1421 or our toll-free number (800) 624-2516.

# Lower Your Rate Of Return.

**C.I.T.O.H.** The One-Way Terminal Company.

CIE Terminals

CIE Terminals, Inc., 2505 McCabe Way, Irvine, CA 92714 • Telephone: (714) 660-1421 (800) 624-2516

© 1987 CIE Terminals, Inc.

VT220 is a registered trademark of Digital Equipment Corporation.

CIRCLE NO. 12 ON INQUIRY CARD

# BREAKPOINTS

## **KIMTRON BEEFS UP PC-COMPATIBLE NETWORKED TERMINALS**

Kimtron Corp. will launch a new line of Satellite PC-compatible terminals next month at Comdex/Spring in Atlanta. The SAT10 and SAT20 come with IBM Corp. PC/AT-style keyboards, serial and parallel ports, three 8-bit expansion slots and built-in color and monochrome graphics adapters and monitors. Both are priced at \$995 (monochrome) and \$1,395 (color) and come with an add-in board to connect them to other PCs. Four SAT10s can run single-user DOS applications off the host PC using Kimtron's \$99 Knet software. Ten SAT20s running IBM's PCNet software can operate multiuser programs off the host PC. By year's end the San Jose company plans to support Arcnet, Ethernet and token-ring networks on other Satellite products.—*Mike Seither*

## **NEW AT&T PRODUCTS EMPHASIZE CONNECTIVITY**

While IBM Corp. prepared its recent product barrage, rival AT&T Co. fired a few salvos of its own. It announced a set of communications products that helps its 3B2 line of minicomputers connect with the machines of other vendors, including IBM, Digital Equipment Corp. and Wang Laboratories Inc. AT&T also brought out two new servers for its 1M-bps Starlan local area network, and enhancements to its packet-switching Information Systems Network (ISN). One of the ISN enhancements is software, scheduled to be available in July for \$5,000, which permits IBM 3270 terminals to communicate with DEC host/terminal networks. Other key announcements: support for IBM's LU 6.2 protocols and software that permits the 3B2 computers to exchange documents in the IBM office environment.—*Jim Donohue*

## **LAN VENDORS OFFER THEIR OWN PC WORKSTATIONS**

Three local area network vendors have announced competing IBM Corp. PC-compatible workstations designed specifically for LANs. They are 3Com Corp. of Santa Clara and Nestar Systems Inc. of Mountain View, Calif., and Novell Inc. of Orem, Utah. 3Com's \$1,895 3Station is an 80286 system with four integrated graphics adapters, Ethernet and 1M byte of memory. Nestar goes to market with three PC workstations, two based on the 8088 and the third on the 80286. The Nestar products all run either on Datapoint Corp.'s ARCnet or token ring and cost from \$895 to \$1,695. Novell's offering is a \$699 diskless network PC. All three companies bank on LAN customers wanting total systems, not pieces.—*Mike Seither*

## **UNISYS INTRODUCES 80386 WORKSTATION**

Unisys Corp. has joined the ranks of workstation vendors offering products powered by the Intel Corp. 80386 microprocessor. The B38 Universal Workstation operates at 16 MHz and runs under BTOS, a multiuser, multitasking operating system from Burroughs Corp., the company now merged with Sperry Corp. to form Unisys. You can cluster up to 11 B38s in a shared-resources environment (disks, printers, communications devices), or you can cluster up to 10 IBM Corp. PCs with one B38 acting as the controller. But you must buy

\$475 Clustershare RS422 interface boards from Unisys for each PC in the cluster. Unisys places a price tag of \$8,375 on a basic B38 workstation, which includes 1M byte of memory and a 20M-byte rigid disk drive.—*Jim Donohue*

### **FUJITSU UNLEASHES SALVO OF HIGH-END PERIPHERALS**

Fujitsu America Inc. will introduce a host of peripherals by mid-May, including its first scanner for OEMs in the United States. The M3094A, priced at \$3,090, scans at 200, 240, 300 and 400 dots per inch. It produces 64 shades of gray and, with an optional \$610 circuit, detects subtle variations. And, the San Jose company will unveil a 5¼-inch, 389M-byte Winchester disk drive with an ESDI interface and an access time of 18 msec that pits Fujitsu against Maxtor Corp., Micropolis Corp., Miniscribe Corp. and Priam Corp. for drives in that range. Also coming: a 3½-inch, 77M-byte Winchester with run-length limited encoding; a 10M-bps intelligent peripheral interface (IPI); a 5¼-inch, 218M-byte half-inch cartridge tape drive; and four 3½-inch flexible drives.—*Mike Seither*

### **APOLLO BRIDGES DOMAIN, ETHERNET**

Augmenting its own token-ring network products, Apollo Computer Inc., Chelmsford, Mass., recently announced Ethernet support for its Domain workstation computing environment. The 802.3 Network Controller-AT, which plugs into the company's Domain Series 3000 workstations, enables direct connection to Ethernet networks. That means system integrators can link up to a variety of other vendors' systems, including Digital Equipment Corp. VAX/VMS and a variety of UNIX machines. The price of a Series 3000 workstation includes either the 802.3 Network Controller-AT or Apollo's original Token Ring Network Controller-AT. If purchased as an add-on, each controller costs \$2,000.—*Dave Simpson*

### **COMMUNICATIONS A FAX OF LIFE FOR EMULEX**

Although a player in data communications only since early this year, Emulex Corp., Costa Mesa, Calif., will begin shipping its third set of modems next month—this time targeting the growing facsimile market. The \$355 HF144 and \$255 HF96 operate over either dedicated telephone lines or general switched telephone networks at 14,400 and 9,600 bps, respectively. The modems will also be marketed to OEMs and VARs in Japan in an effort to crack the Japanese fax market where Rockwell International Corp. is presently the sole U.S. supplier of modem boards. Marketing manager Roger Free says Emulex will compete on the basis of lower power consumption, smaller size and surface-mount technology.—*Tim Scannell*

### **IBM BLESSES OPTICAL DISK DRIVES—AT LAST**

IBM Corp. has ended its long holdout and entered the optical storage business with the 3362, an external, 200M-byte WORM optical disk drive. "It gives IBM a way to learn what the optical market is all about," says industry analyst Bob Katzive of Disk/Trend Inc., Los Altos, Calif. The 3363, which carries a price tag of \$2,950, is built for IBM by Matsushita of Japan. With attachments, says IBM, it can hold 1.6G bytes of data. The drive will be available in the second quarter. Meanwhile, IBM is working on an optical disk

# 60 Megabytes is more than the other guys can swallow.

When it comes to maximum storage on a single Philips streaming cassette back-up, Teac stands alone.

With our MT-2ST and CT-600H cassette tape we've made a giant leap over the competition. Its 90 ips performance can back-up an incredible 60 megabytes in only 12 minutes. And this is data on a medium that's totally interchangeable from drive to drive.

To make sure things are what they seem, our read-after-write system constantly checks data integrity. We've included a built-in data formatter logic board, and all three commonly used data streamer interfaces are available: D/CAS-05 (QIC-02), SCSI, or D/CAS-15 (QIC-36).

Teac's reliable servo-controlled direct reel drive is free of belts and mechanical complexities to jam-up or break-down.

All of this in a half-height unit that requires no warm-up or the need to preformat the recording medium.

For fast, simple, and reliable relief from back-up worries, take a Teac —you'll feel better in the morning.

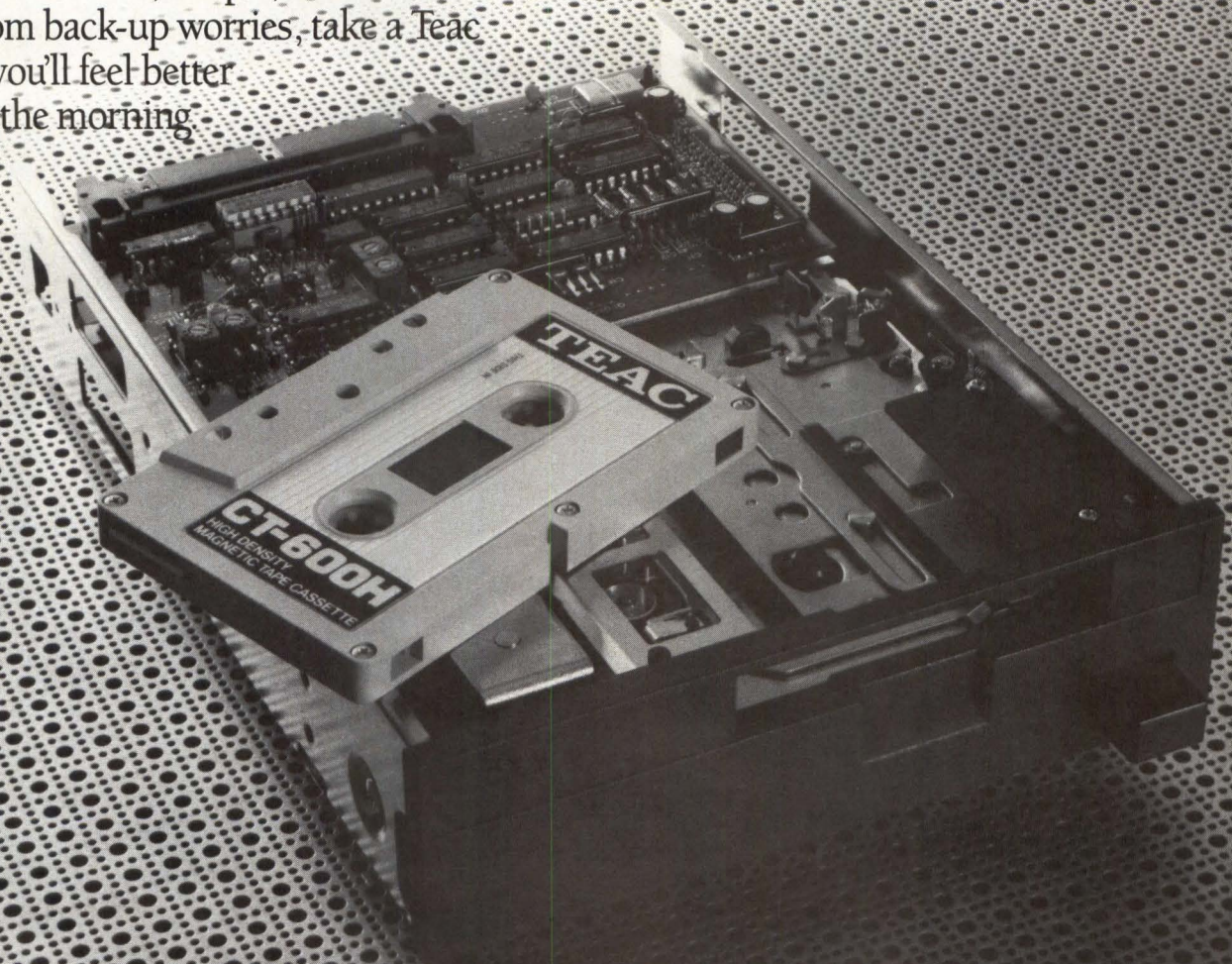

Built To Fanatical Standards. **TEAC**

INSTRUMENTATION AND COMPUTER PRODUCTS DIVISION, 7733 TELEGRAPH ROAD, MONTEBELLO, CA 90640

East (617) 475-7311 South/Midwest (312) 934-4411 Rocky Mountain (602) 242-4025 (303) 368-8677 (801) 532-2111

Northwest (408) 727-1427 Southern California (213) 726-0303

CIRCLE NO. 13 ON INQUIRY CARD

© 1986



# Series 32000 makes VAX power more personal.

**NOW YOU CAN JOIN HEWLETT-PACKARD, FUTURENET, EATON, COMPUTERVISION, AND OVER 50 OTHER COMPANIES IN BRINGING 32-BIT POWER TO THE LARGEST INSTALLED BASE IN THE WORLD**

There are over 10.7 million\* IBM® personal computers and compatibles in use today. That's the largest "installed base" in the world — an enormous pre-existing market that represents an enormous marketing opportunity. And National Semiconductor is leading the way for OEMs, systems integrators, VARs and VADs to take full advantage of it.

Because it's now possible to put the power of a VAX™ 11/780 into the PC environment. At a mere fraction of the cost.

PC add-in boards, based on National's Series 32000® family, allow you to immediately upgrade almost any personal computer to true 32-bit performance.

Simply by plugging a Series 32000-based board into one of the computer's standard expansion slots,\*\* you can deliver the power and speed of a \$30,000 workstation for about \$3,000.

That means you can put high-performance CAE/CAD capabilities onto every engineer's desktop. You can distribute more computing power to more people at a lower cost in a multiuser, multitasking office environment.

\* Source: Infocorp 1987

\*\* For IBM PC/XTs, PC/ATs, and compatibles. Standard PCs need to be upgraded with a hard disk (10 Mbyte, minimum) and a larger power supply.

Series 32000 is a registered trademark of National Semiconductor Corporation.

IBM is a registered trademark of International Business Machines Corporation. VAX is a trademark of Digital

Equipment Corporation. UNIX is a trademark of AT&T. © 1987 National Semiconductor Corporation.

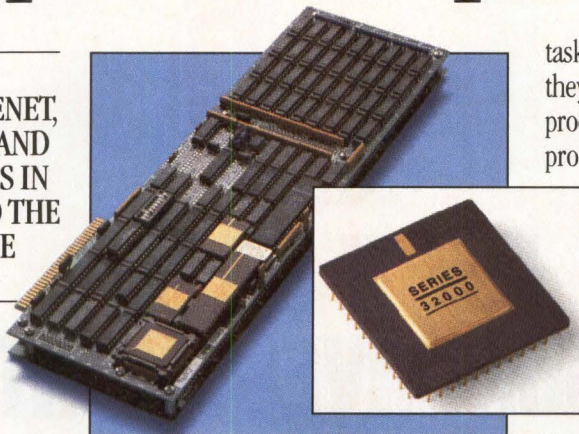

You can capitalize on the hot new market in desktop publishing. The opportunities are endless.

## DELIVER TRUE 32-BIT POWER

Already more than 50 key systems integrators, VARs and VADs have realized the potential of this market by using PC add-in boards.

And more PC add-in board manufacturers are using the Series 32000 than all other 32-bit microprocessors combined.

That's because no other 32-bit microprocessor offers a more complete, integrated family of solutions, including coprocessors, peripherals, software, and development tools.

And, because the entire family was designed with the same highly symmetrical, orthogonal 32-bit architecture, the Series 32000 is fully software-compatible across all its CPU offerings. So your customers' software investment is completely protected even as they migrate to higher performance.

## BRIDGE THE UNIX-DOS GAP

A Series 32000-based add-in board gives your customers the best of both worlds in operating systems. Since the Series 32000 was the first 32-bit microprocessor to support full demand-paged virtual UNIX™, your customers can run high-performance engineering and business applications in the most cost-efficient multiuser, multi-

tasking environment in the industry. Yet they can still run important personal-productivity tools like spreadsheets, word processing, and project managers under DOS.

## PLUG INTO THE MARKET NOW

Obviously, the potential of the PC add-in market is enormous. And it's already being tapped with Series 32000-based boards being manufactured by a number of OEMs. If you're a systems integrator, VAR or VAD, contact one of these companies about their products.

Or if you're a board-level OEM yourself, follow their lead by contacting National Semiconductor about how you can design the Series 32000 into your own product.

### PC ADD-IN COMPANIES USING SERIES 32000

#### Selected OEMs

Aeon Technologies, Vail, CO (303) 986-3599  
 Cybertool Systems USA, San Jose, CA (408) 263-1700  
 Definicon Systems, CA (818) 889-1646  
 DFE Electronic Data Systems, CA (415) 829-3925  
 Hightec EDV Systems, Saarbrücken, Germany  
 Matrox Electronic Systems, Quebec, (514) 685-2630  
 Opus Systems, Cupertino, CA (408) 446-2110  
 Sritek, Cleveland, OH (216) 526-9433  
 Zaiaz, Huntsville, AL (205) 881-2200

#### Selected VARs

|                       |                        |
|-----------------------|------------------------|
| Analog Design Tools   | Lattice Logic USA      |
| Auto-Trol Technology  | Matrox Elec. Sys.      |
| Cambridge Graphics    | National Semiconductor |
| Computervision        | Oasys                  |
| Cybertool Systems USA | Olivetti               |
| Hightec EDV Systems   | Siemens AG             |

Either way, the PC add-in market represents one of the most significant business opportunities in years. With over 10,000,000 prospective customers. And the Series 32000 can help you reach every one of them.

Personally.

National Semiconductor  
 MS 23/200  
 P. O. Box 58090  
 Santa Clara, CA 95052-8090

 **National Semiconductor**

**CIRCLE NO. 14 ON INQUIRY CARD**

# Attention DEC users:

*If you own a*

**PDP 11/34  
PDP 11/04  
PDP 11/24  
PDP 11/40  
PDP 11/60**

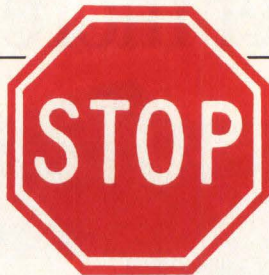

*If you run*

**RSTS  
RSX  
RT 11  
UNIX  
MUMPS  
GAMMA 11**

## **DON'T SCRAP YOUR INVESTMENT!**

*Triple performance with the  
NISSHO N1100 SINGLE BOARD COMPUTER  
... The "LATE LIFE KICKER"\*  
for PDP 11/04, /24, /34, /40 or /60's.*

*Combine the power of the J-11 with 2 Megabyte and high speed memory  
on a single hex board. Just drop it into any SPC slot and transform your  
state of the past components into a state of the art machine.*

*The N1100 makes an ideal front end processor  
for any DEC compatible network you may be planning.*

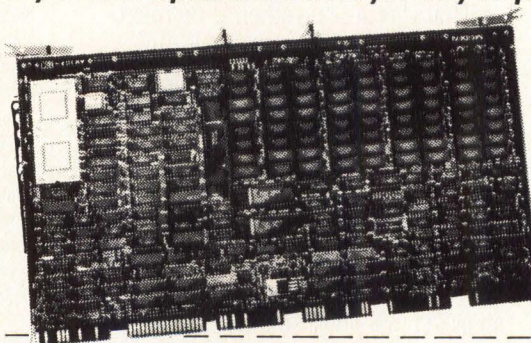

PDP 11/34, PDP 11/04, PDP 11/24,  
PDP 11/40, PDP 11/60, RSTS,  
RSX, RT 11 are registered trademarks  
of DIGITAL EQUIPMENT COMPANY

\*N1100 has been so designated  
by Digital Review September  
1985.

A reprint of this article will be  
included with material sent in  
response to inquires from  
this ad.

**For  
Information  
use our  
SPEEDY  
REPLY  
COUPON**

- YES!** Please RUSH all available information on the Nissho N1100 by return mail.  
 Have your representative contact me at the earliest possible moment and  
tell me all about the "Late Life Kicker" and how easily it can convert my  
system to 'state-of-the-art' performance.

NAME \_\_\_\_\_

COMPANY \_\_\_\_\_

ADDRESS \_\_\_\_\_

CITY, STATE, ZIP \_\_\_\_\_

TELEPHONE & AREA CODE (     ) \_\_\_\_\_

Please reply to:

Nissho Electronics (U.S.A.) Corp., Suite 200, 17310 Redhill Ave., Irvine, California 92714

**SPEEDIER REPLY  
WITH NO COUPON**

For full information  
call Ed Griffin  
**1-800-233-1837**  
Ext. 660

In California call  
**1-714-261-8811**  
Ext. 660

**NISSHO ELECTRONICS  
(U.S.A.) CORP.**  
17310 Redhill Avenue,  
Suite 200  
Irvine, California 92714

**NE NISSHO**



drive of its own design. That work is underway in Tuscon, Ariz. Says one official with optical drive competitor Maxtor Corp., "The significance [of the 3363] is that IBM has finally blessed WORM technology. It's something we've all been waiting for."—*Mike Seither*

## **MULTIFUNCTION OPTICAL DRIVES DUE THIS YEAR**

Optimem Inc., Sunnyvale, Calif., says it will have multifunction optical disks and drives in the 5¼-inch form factor in beta test this summer and expects to ship the product in volume in the fourth quarter. At least one other company—Maxtor Corp., San Jose,—says it is looking into multifunction drives with the idea of having a product on the market in 1988. Larry Fujitani, director of marketing for Optimem, says his company's drives will combine WORM and CDROM technologies with the newly developed erasable technology. 3M of St. Paul, Minn., will supply the recording media and the disks.—*Jim Donohue*

## **COMMITTEE GOES BOTH WAYS ON OPTICAL FORMATTING STANDARD**

Following the lead taken earlier this year by the Japanese, the ANSI X3B11 committee has voted to pursue two competing standards for formatting write-once 130-mm optical disk drives. But that decision, some members think, could be reversed by another vote when the committee meets again this month. One camp favors the composite/continuous method, which interlaces servo information with data. The other group leans toward the sample servo technique, which physically separates servo information from data on the disk. The committee decided on the twin-standard approach after being unable to reach a consensus on the issue for more than a year.—*Mike Seither*

## **DO MEGA-MEMORY CHIPS THREATEN TO REPLACE MAGNETIC MEDIA?**

"DRAM (dynamic RAM) chips always go to \$2." That's been a constant economic law for solid-state memory. Prices start much higher and then fall as manufacturers achieve economics of scale and control over the chip-making process, according to San Francisco's *California Technology Stock Letter*, quoted above. Noting IBM Corp.'s recent announcement of a 4M-bit DRAM chip—and hints at 16M-bit, 64M-bit and 256M-bit chips—the newsletter editors believe solid-state memory will soon be a cost-effective replacement for magnetic disk drives. By 1991 semiconductor memory prices will be about \$10 per megabyte, vs. \$15 per megabyte for 14-inch Winchester disks and \$10 for 8-inch Winchesters. That, the editors say, will be low enough for IBM Corp. to announce "solid state replacement products for their largest computers as soon as 1988 or early 1989."—*Mike Seither*

## **ISDN KEEPS COMMUNICATIONS IN THE CHIPS**

Systems integrators should keep abreast of developments in integrated services digital networks (ISDN). For one thing, Advanced Micro Devices Inc. of Sunnyvale, Calif., one of the five top U.S. chip suppliers, will start shipping toward the end of this year an ISDN protocol controller designed to easily connect terminal equipment with digital PABXes. The device should increase ISDN's real-time capabilities, and that is what communications integration is all about. For another thing, the ISDN market is expected to mushroom from about \$500 million this year to more than \$3 billion by 1995, says AMD Group vice president John East.—*Tim Scannell*

## **INTEGRATORS VENT MASS-STORAGE BEEFS**

"Every storage device or controller we use has shut down our production line at least once," complains Jon Garman, director of I/O engineering for Sun Microsystems Inc., Mountain View, Calif. Garman spoke out as one of a panel on "Insights from Storage Device Integrators" at Dataquest Inc.'s April storage-industry conference in San Jose. Garman asserted that drives and controllers are often not compatible "though advertised as such." Gripes from other panelists: non-standard "standards" like the ESDI interface, which has several different transfer rates.—*Mike Seither*

## **PLUS PRODUCES 40M-BYTE HARDCARD**

Plus Development Corp., the Milpitas, Calif., company that started the drive-on-a-card business two years ago with a 10M-byte device, began shipments in early May of its 40M-byte HardCard. Unlike many competing drive cards that require one and a half personal computer expansion slots, Plus Development has retained its original sleek design and still takes up only a single slot. The HardCard 40, which uses run-length limited encoding, retails for \$1,195. Plus claims it has shipped a total of 200,000 10M-byte and 20M-byte HardCards.—*Mike Seither*

## **BREAKING THE LISP LANGUAGE BARRIER WITH COBOL**

Citing an "academic bias" toward LISP in the area of artificial intelligence applications, Cullinet Software Inc., Westwood, Mass., has taken the wraps off a series of expert-system programs based on the COBOL programming language. It marks the company's first entry into AI applications since it acquired Distribution Management Systems (DMS) of Lexington, Mass. OrderEXL, SalesEXL, VoiceEXL and the DMS Application Expert all support COBOL and SQL file conventions. As a result, they can more easily integrate with commercial applications. Their framework also eliminates the need for dedicated hardware and complicated compilers. Besides, if the application is successful, "the underlying language becomes somewhat irrelevant," claims John Landry, former DMS CEO and now an executive vice president at Cullinet.—*Tim Scannell*

## **HAND-HELD SCANNER AIMS AT SPREADSHEET USERS**

Typical scanners load a complete page of type into a computer. Now Saba Technologies, Beaverton, Ore., is bringing out an optical character reader that selectively enters information into popular spreadsheet, word processing and database programs. About the size of a mouse, the \$695 device, called the Hand Scan, can be used to read small bits of information, such as a group of numbers, and enter them into a spreadsheet's cell or a word processing file. The reader connects to an IBM PC Corp. or compatible through a full-size add-in card. Among other programs, it supports Lotus 1-2-3, WordStar, WordPerfect and MultiMate.—*Mike Seither*

**FOR 10 YEARS  
WE'VE WATCHED  
THE UPS  
AND DOWNS  
OF THE  
COMPUTER  
BUSINESS.**

# FORTUNATELY EXPERIENC

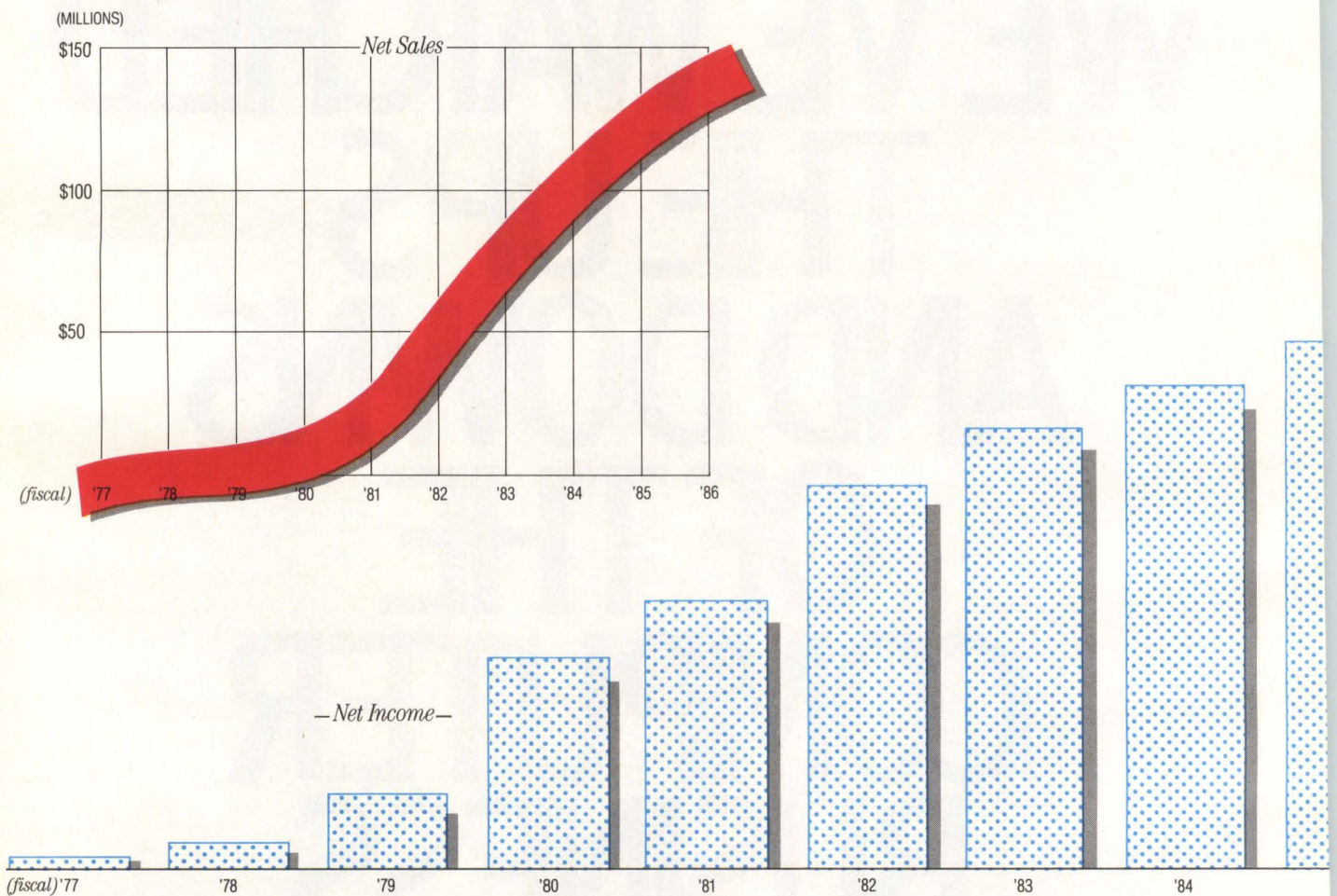

Computers can be a volatile business. Overnight success stories become overnight failures. Innovation fast gives way to obsolescence.

But for 10 years, Altos has performed brilliantly.

In the beginning, Altos created a powerful, cost-effective multi-user system flexible

enough to integrate with P.C.s, minicomputers and mainframes. Since then, we've continued to break new ground with computer systems that offer more and more power and connectivity for each and every dollar spent.

The market has responded. Sales have grown every year

of our existence. We've been profitable every quarter for ten years. Today, Altos computers are sold in 65 countries around the world.

Another major reason for Altos' success is a total commitment to the VARs and OEMs who sell our systems. It is support that Dataquest has called

\*Includes gain on sale of investment in affiliated company.

# WE'VE ONLY ED THE UPS.

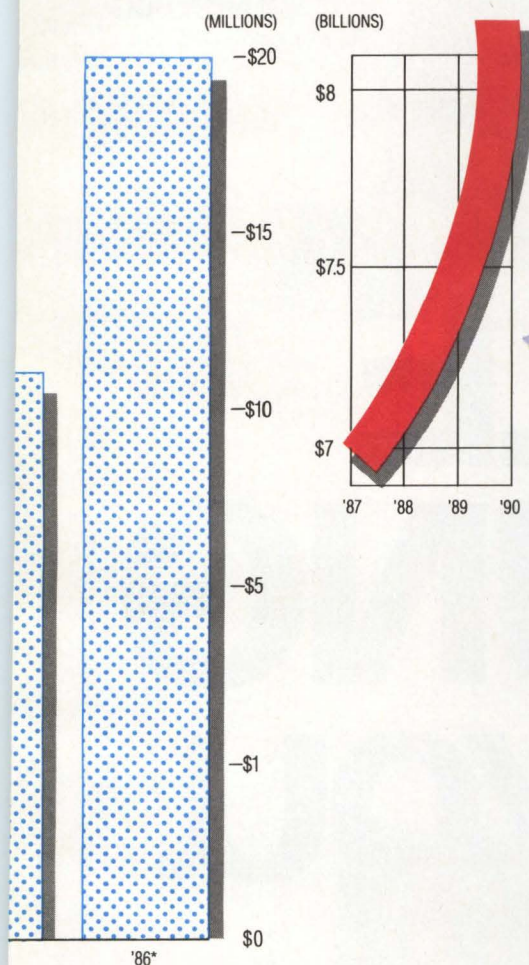

Projected World Growth in  
Multi-user Systems, \$25,000 - \$50,000  
(Source: Dataquest)



“unmatched in the industry.”

We start by arming our VARs and OEMs with a complete marketing program. It includes turn-key direct mail, vertical sales support, the advice of our expert marketing staff, and a comprehensive, responsive customer service plan.

Equally important, we offer

our VARs and OEMs the biggest profit margins in the business. And we have no direct sales force to compete with them.

Technical innovation, planned growth, and unwavering technical and marketing support for our customers.

All together, that's what makes Altos work.

And that's why we've experienced the ups.

Without the downs.

1-800-ALTOS U.S.

**ALTOS**

COMPUTER SYSTEMS®  
2641 Orchard Parkway, San Jose, CA 95134

CIRCLE NO. 17 ON INQUIRY CARD

It had to happen.

After years of building high-quality, low cost terminals and monitors to American specs, Samsung has gone American all the way.

We've established a stateside group to handle your needs. Samsung Electron Devices.

Besides providing liaison with Korea, we have an American design team on staff. So you can get terminals and monitors designed right to your specs. With ease. Because there's always somebody on your side of the Pacific to talk to.

What's more, we can deliver 12" and 14" terminals that emulate America's most popular models. Plus we offer a variety of monitors, including color, in several cabinet styles, that also emulate America's most popular models. (In many cases, they already are the most popular models in the states.)

Our perfected manufacturing techniques keep the costs down. And our automated, robotic assembly lines turn out everything from CRTs to terminals to computers that meet U.S. standards. Without any inscrutable delivery delays along the way.

In short, we have what it takes to do business your way. The American Way.

Join up with Uncle Samsung.

Call 213/404-1835.

It's a great way to serve your company.



CIRCLE NO. 18 ON INQUIRY CARD

# UNCLE SAMSUNG WANTS YOU.

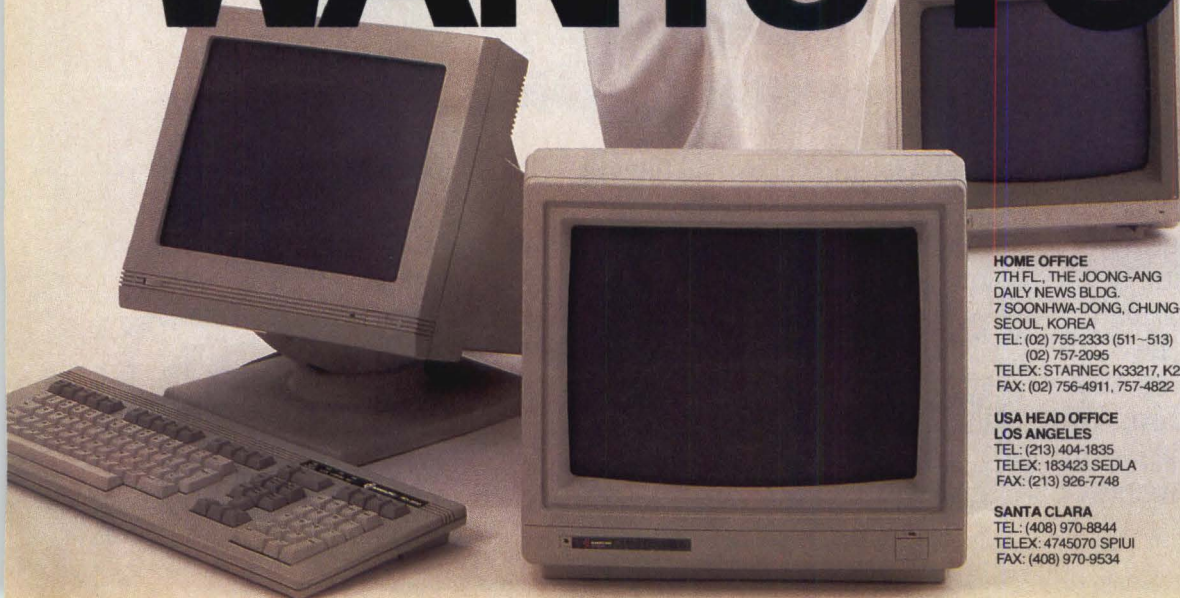

**HOME OFFICE**  
7TH FL., THE JOONG-ANG  
DAILY NEWS BLDG.  
7 SOONHWA-DONG, CHUNG-KU  
SEOUL, KOREA  
TEL: (02) 755-2333 (511-513)  
(02) 757-2095  
TELEX: STARNEC K33217, K22596  
FAX: (02) 756-4911, 757-4822

**USA HEAD OFFICE**  
**LOS ANGELES**  
TEL: (213) 404-1835  
TELEX: 183423 SEDLA  
FAX: (213) 926-7748

**SANTA CLARA**  
TEL: (408) 970-8844  
TELEX: 4745070 SPIUI  
FAX: (408) 970-9534

**TOKYO**  
TEL: (03) 581-5804, 581-9521/4  
TELEX: 2228009 SANSEI  
FAX: (03) 581-4835

**LONDON**  
TEL: (01) 831-6951/5  
TELEX: 264606 STARS LG  
FAX: (01) 430-0096

# MINI-MICRO SYSTEMS

---

## PRODUCT SPOTLIGHT

COVER STORY

### Passive backplane proves active strategy at Wyse

Mike Seither, Senior Editor

Terminals and monitors have been the backbone of business at Wyse Technology ever since the company was founded six years ago. But IBM Corp.-compatible personal computers are now becoming an increasingly important part of the company's product mix.

Last year, for example, personal computers—the Intel Corp. 8088-based WYSEpc+ and the PC/AT-class WYSEpc 286—accounted for almost one-quarter of the San Jose company's \$200 million in revenues. What's more, personal computer-related income is expected to reach nearly \$60 million this year and close to \$95 million in 1988, according to Hambrecht & Quist Inc., a San Francisco investment banking concern.

This month Wyse moves whole hog into the personal computer arena with a full line of highly flexible products for system integrators, OEMs and value added resellers. Unlike its previous machines, which were built around a typical motherboard that held the main processor and its related logic, Wyse has switched to a new design called "modular system architecture." It's akin to the approach taken by vendors of minicomputers and industrial systems that use single-board processors, and that control memory and video characteristics by way of secondary CPUs on separate add-in boards.

In Wyse's case, those secondary CPU boards, home to a variety of processors running at different clock rates, slip into standard 8-bit or 16-bit expansion slots. Wyse plans to market modular personal computers that can



**Wyse Technology** has outfitted its WY-2112 personal computer with programmable liquid crystal displays for indicating time and date, test and configuration information and messages for networked users.

be configured with Intel's 80286 and 80386 microprocessors. The basic systems—the WY-2108, WY-2112, WY-2214 and WY-3216—are available immediately and range in price from \$1,900 to \$3,500.

Wyse believes the simple design will appeal greatly to system integrators, who can choose the processing unit best suited to individual needs. Moreover, those customers can also pick a chassis with the desired amount of space for more add-in boards and mass storage devices, yet still mix and match processor boards. The only differences are in the size of the chassis and the length of backplane.

"The architecture has value for OEMs, users, service organizations and us," says Steven Holzman, direc-

tor of product marketing at Wyse. "It's a lot more efficient and cost-effective." The reason: Add-in cards can be swapped easily. On the other hand, fixing or upgrading a motherboard usually means taking the whole system apart, thereby adding time and cost to the work. The systems' modular design also means less training and on-site work is required of field technicians—a fact Wyse believes will attract a lot of OEMs.

#### Adding punch when needed

Finally, OEMs can order a tailor-made system but not be locked into purchasing a whole new machine when their customers need more processing power. Instead, they can add processor boards for more punch, as necessary.

# The Workgroup Server™ Family:

There are only three primary colors. But by mixing and matching these three colors, an artist can create any color in the rainbow. This is the principle we've used in developing our computer solutions.

Standards. Enhancements. Connectivity.  
Convergent has put them all together in a family of Workgroup Servers that give resellers the leverage to solve a wide variety of specific problems.

We started with industry standards for hardware, operating systems, networking and software. Things like UNIX\* System V, Motorola's 68000 microprocessor family, and VME and SCSI buses. The standards.

Then we enhanced these standards to give your customers increased performance and productivity. The simple windowing interface to UNIX is one example. Our fully integrated office automation package is another.

And finally, we went one more step and connected our Workgroup Servers to a wide range of computers



*The S/320:*  
A 32-user system with optional VME expansion.

*Third party packages like Ultra-Office from Lutzky-Baird enable you to connect Apple Macintoshes and IBM PCs to your Workgroup Servers.*

*With our PC Exchange™ software, Workgroup Servers connect heterogeneous LANs to share mail, file servers, print servers and common relational databases.*

*The S/640:*  
At 25 MHz, the S/640 is a processing powerhouse, supporting up to 64 users.

*IBM PCs gain access to our UNIX databases through Multiplex\* a PC-UNIX interconnect.*

Workgroup Server is a trademark and Convergent is a registered trademark of Convergent Technologies, Inc. UNIX is a trademark of AT&T. IBM is a registered trademark of International Business Machines Corporation. Apple and Macintosh are registered trademarks of Apple Computer Corporation.

**CIRCLE NO. 19 ON INQUIRY CARD**



# Where great systems converge.

from other vendors. Including IBM\* PCs and compatibles, Apple\* Macintoshes,\* other UNIX-based systems and IBM minis and mainframes.

Sound interesting? There's one more thing.

Convergent offers a comprehensive VAR program to complement this strong product offering. Featuring the margins and support services you'd expect from a company exclusively dedicated to resellers.

With no cross-channel conflict.

Standards, enhancements, connectivity and a great VAR program. To find out more about these areas of opportunity, call us today at 1-800-832-2255, ext. 296. In Europe, ring 44-3444-11707. Or write us: Convergent Technologies, 2700 North First Street, San Jose, CA 95150-6685, Mail Stop 10-015.

We'll help you find the end of the rainbow.

## The S/1280:

The most expandable system in the Workgroup Server Family, it uses multiple processors to support up to 128 users.

Our fully integrated WGS/Office™ automation software includes a windowing interface, word processor, spreadsheet, calendar and electronic mail.

## The S/220:

68020 performance for up to 22 users in a small package.

## The S/50:

A "personal" UNIX system that doubles as a server for up to five users.



## THE WORKGROUP SERVER FAMILY

|                   | S/50™               | S/120™                | S/220™                | S/320™                | S/640™              | S/1280™                  |
|-------------------|---------------------|-----------------------|-----------------------|-----------------------|---------------------|--------------------------|
| Max Users         | 5                   | 12                    | 22                    | 32                    | 64                  | 128                      |
| Max RAM           | 2 MB                | 5 MB                  | 5 MB                  | 16 MB                 | 64 MB               | 24+ MB                   |
| Max Disk Storage* | 80 MB               | 140 MB                | 280 MB                | 4.0 GB                | 4.0 GB              | 6 GB                     |
| Technology        | 10 MHz<br>68010 CPU | 12.5 MHz<br>68020 CPU | 12.5 MHz<br>68020 CPU | 12.5 MHz<br>68020 CPU | 25 MHz<br>68020 CPU | 4x16.67 MHz<br>68020 CPU |
| MIPS              | .75                 | 2.0                   | 2.0                   | 2.0                   | 4.25                | 8.8                      |

\*storage listed in unformatted capacities

# Convergent

When great ideas converge, great products emerge.

Some industry observers say that the time has come for a strategy like Wyse's. "I don't know why they [personal computer vendors] have waited so long before moving toward a pas-

sive backplane," says a bemused John Lemons, president of Faraday Electronics. Faraday, Sunnyvale, Calif., has made a business of manufacturing single-board personal computers for industrial applications. "It's a

much quicker way to get technology to market," claims Lemons.

Indeed, time-to-market was a major consideration in opting for the backplane approach, says Christopher Kryzan, the Wyse product manager in charge of the modular personal computer line. "Instead of redesigning a complete system, we'll change only the boards. It will allow us to respond to market trends much faster. OEMs typically take a long time to get into new technology. Many are still selecting 80286 systems, but the 386 revolution has already started. Our modular approach will let OEMs react to the market as fast as retail manufacturers."

**Lots of slots**

Although Wyse plans to customize systems for OEMs and system integrators, the four initial systems will be aimed at so-called "niche" users and will share many common features (see Table). For instance, all of the systems are configured with 8-MHz and 12.5-MHz versions of the 80286 16-bit chip or with the 16-MHz, 32-bit 80386. Base prices include a single 5 1/4-inch flexible disk drive. However, Wyse is offering system integrators wide latitude in choosing peripherals. Flexible disk drives are available in capacities of 360K bytes, 760K bytes (in a 3 1/2-inch form factor) or 1.2M bytes; rigid disk drives come in 20M-byte, 40M-byte and 70M-byte capacities. Systems with the smaller, seven-slot, chassis can accommodate three half-height devices. The larger chassis has nine slots and holds one full-height and three half-height mass storage devices.

Standard onboard main memory on the 80286 CPU cards is half a megabyte, expandable to 1M byte. The top-of-the-line 80386 machine, the model 3216, can have up to 24M bytes of static RAM. That system utilizes a dedicated 32-bit memory bus so that additional memory cards can reside in any slot in the system. To ensure hardware compatibility with other add-in boards on the market, Wyse uses an 8-MHz PC/AT-compatible system on all the new systems. Switchable modes allow timing-sensitive applications to run compatibly. In addition, Wyse has

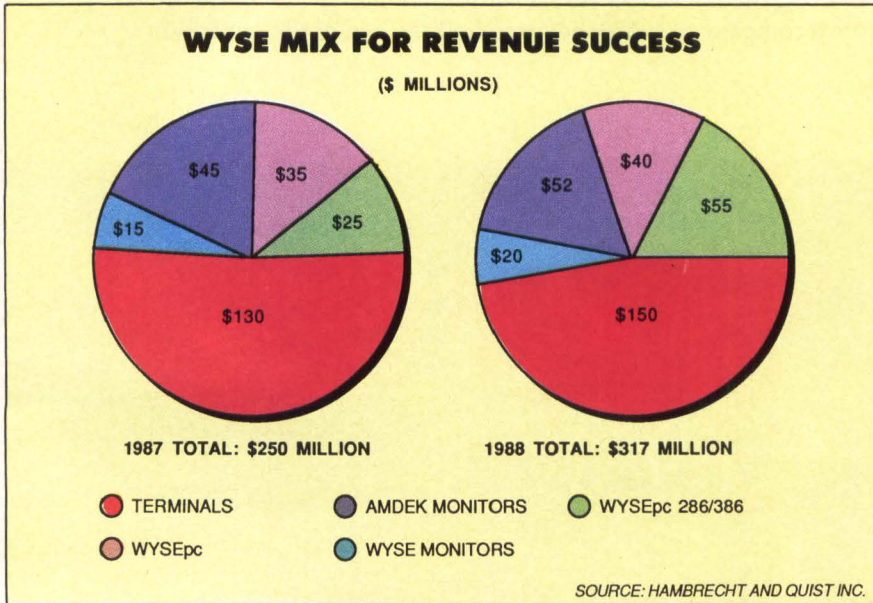

# HI-TECH NOISE KILLER

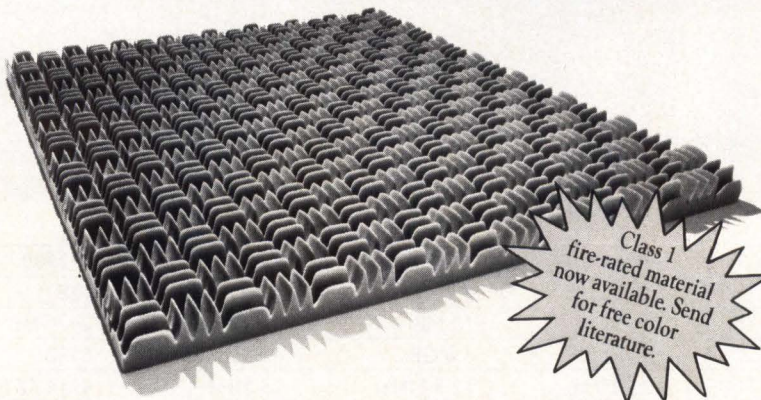

Class 1 fire-rated material now available. Send for free color literature.

SONEX acoustic foam is deadly to annoying computer room noise. And it'll look great in your hi-tech environment. Simply hang sheets of this patented, professional foam to quiet the combined clatter of fans, motors and printers. Call or write for complete facts and a free brochure: 3800 Washington Ave. North, Minneapolis, MN 55412. (612) 521-3555.

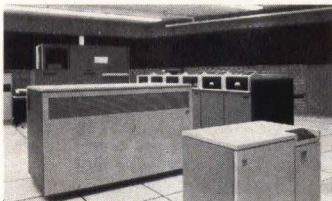

**illbruck**

CIRCLE NO. 20 ON INQUIRY CARD



We understand the  
position you're in when you need  
to rent an instrument.



# “Please, oh please have

## Introducing MetriCard™

Prayer and good living won't do it.

But the MetriCard will. It's the easiest, fastest, most hassle-free way for you to get the instrument you need. When you need it.

You see, MetriCard lets you choose from Leasametric

Instrument Rental Division's fabulous selection of electronic and telecommunications test, measurement and development equipment. Thousands of products from more than eighty top manufacturers.

You'll have a pre-approved credit line. So all you have to do is pick up the phone and order the instrument.

No divine intervention is necessary. In fact, if you're trying to meet one devil of a schedule, you can get your instrument within 24 hours.

Find true meaning.  
And discounts, too.

MetriCard gives you instant, toll-free access to our staff. And, heaven forbid, if we can't help you instantly, we guarantee we'll get back to you within 30 minutes.

With MetriCard, you even move to the head of the line. Your orders get first priority all the way from processing to shipping to servicing.



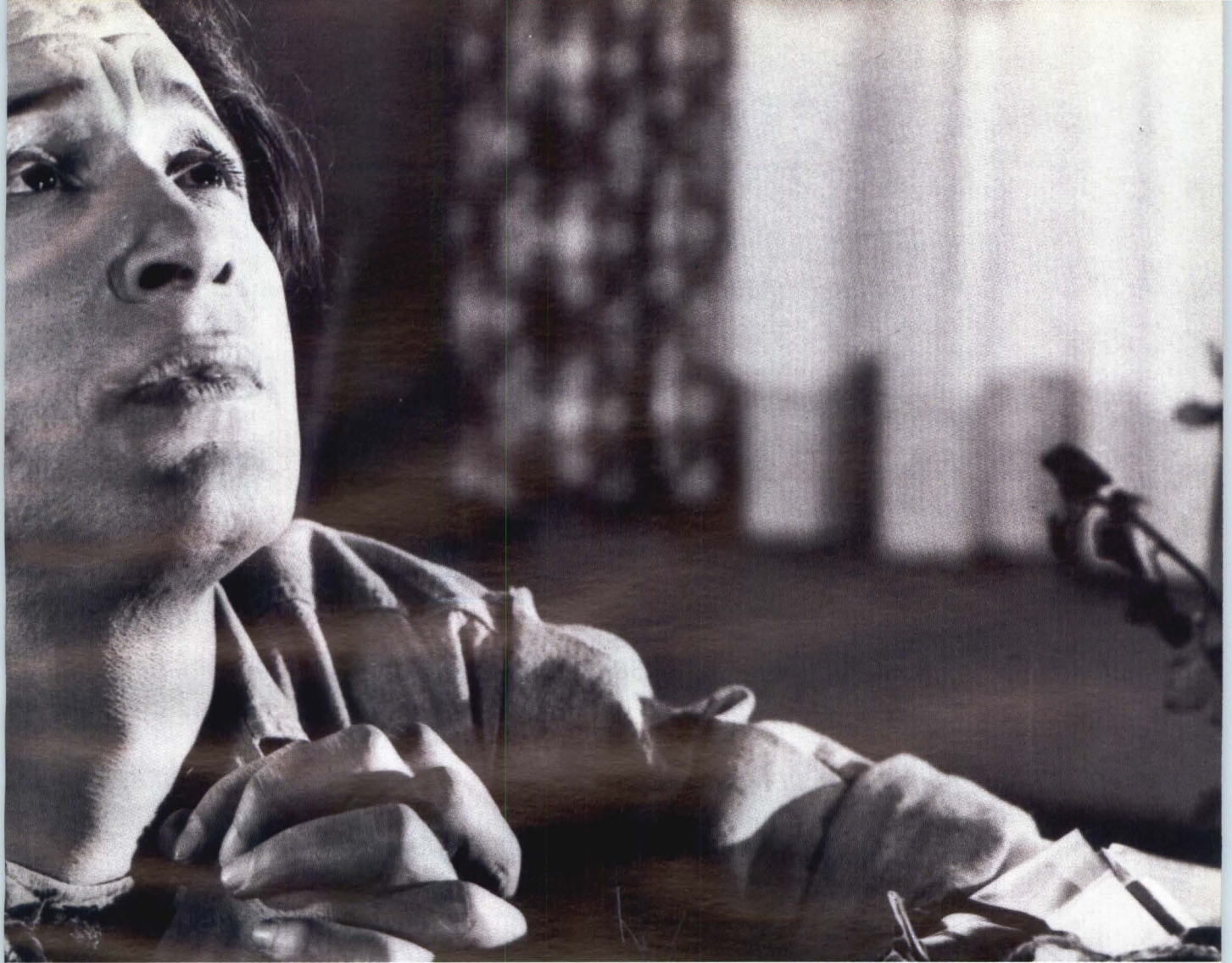

## the instrument I need.”

Plus you get bonus points that are good for discounts on metrology services, rentals and purchases.\*

Let us not be dogmatic.

MetriCard gives you lots of choices.

You can get the rental plan that fits your short or long-term needs. Month-to-month rentals. Five-year leases. Or anything in between. Even rent with an option to buy. You can also make outright purchases (at very attractive terms) from our huge inventory.

So why wander aimlessly? We've been providing answers for 25 years. Send in your MetriCard application today. You'll see why you get more than just an instrument when you rent with Leasametric.

\*Some limitations may apply.

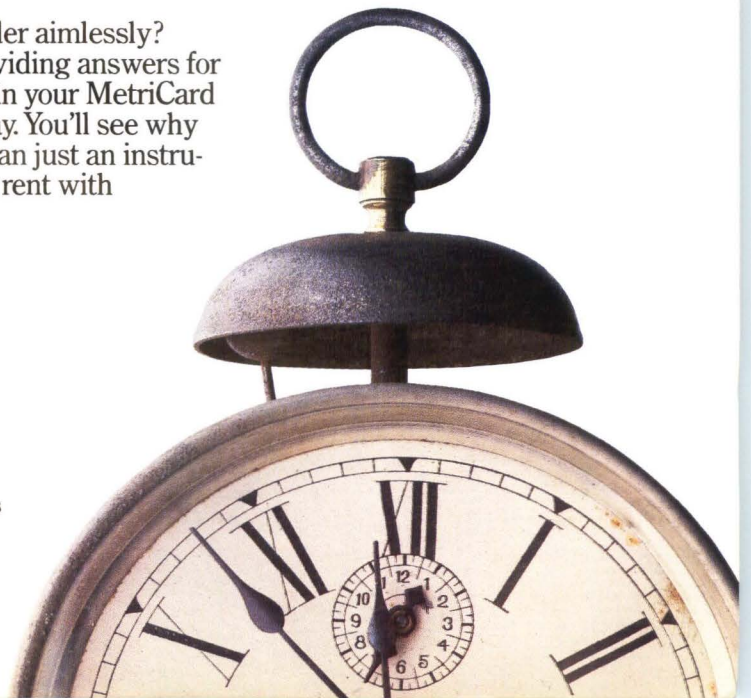



# “When was the last time you

Go ahead. Try tracing an offbeat bit or measuring that last microvolt with an instrument that's not quite calibrated to perfection. It's like listening to one musician playing in the key of r major twelfth. Just a lot of noise.

That's why we go to such

extraordinary lengths to test and analyze every instrument we handle. So you can be certain your tests and analyses are accurate and reliable.

Never  
out of tune.

Before you get an instrument from us, it is calibrated to the manufacturer's specifications. Every nit is picked so you can rest assured the piece of equipment you get has been thoroughly tested. And fully inspected.

And that goes for every instrument we carry. Analyzers. Meters. Recording devices. Signal sources. Transmission test equipment. Microprocessor test and development equipment. The list goes on and on. With products from the best names in the

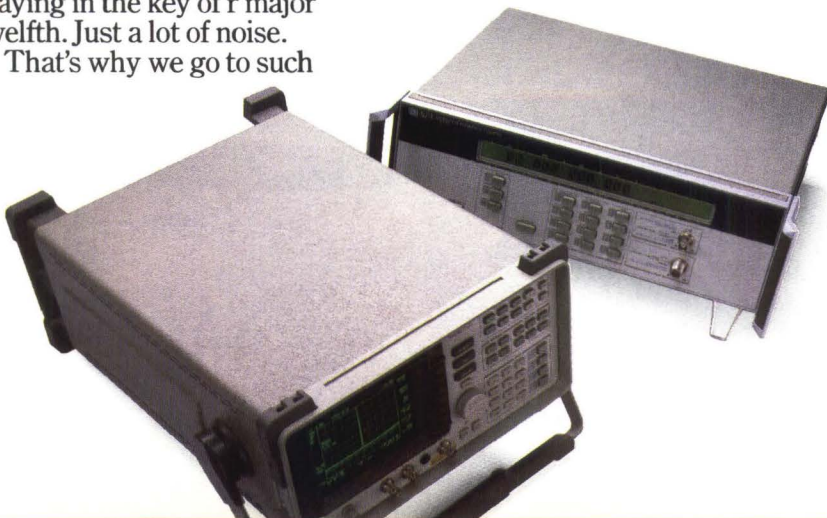



## guys tuned your instruments?”

business: H-P, Tek, Fluke, Anritsu,  
Tau-Tron and more.

### A final note.

Your instrument will work.  
Exactly as it should. And it'll keep  
on working perfectly. In fact, our  
success rate shows that 99.4%  
of our equipment performs flaw-  
lessly month after month.

So join up. Send in your  
MetriCard application today. You'll  
see why you get more than an  
instrument when you rent with  
Leasametric.





# “Yeah, we got Now would somebody

The instrument arrives. It's a real dandy. But it has been a few months since you've used one of these things. And... well...how does

that probe connect to one of those inputs?

Mysteries abound. It's not a pretty sight.

No secrets.

When your instrument comes from us, it arrives with full disclosure. All of

the set-up and operations manuals are included.

You'll also find the right accessories packed with the equipment. So you don't have to skulk around looking for plugs or connectors.

Call if you haven't a clue.

Don't be shy. If you run into a problem, no matter how complex (or how simple, for that matter), just use our toll-free hotline.

You'll get all the help you need. From a technical professional. Advice on configurations,







# the instrument. please tell us how to use it.”

applications, even general chit-chat about equipment specifications.

It's a small world.

Think you're on your own in a dark corner of Marseilles? Forget it.

Because our services are available around the world. From our offices in Canada, the European Continent and the good old U.S. of A. Not to mention our affiliates in a host of out-of-the-way places.

It's no mystery.

If you've got a phone, you've got the answer. Because you'll get the equipment you want, properly calibrated and delivered with full documentation. Then get all the help you need after the equipment arrives.

That's why we're the stable, reliable industry leader we are. And why you know you get more than just an instrument when you rent with Leasametric.





# “Well, Belle. I reckon it’s time we got us a MetriCard.”

Yep. There’s simply no easier, faster way to get the instrument you need. To make sure it’s set up the way you want. To be certain you’ll have all the manuals and accessories. And to get

that extra help when times are troubled.

## Don’t Go To Work Without It.

Send in your MetriCard application today. And if some varmint took the attached

application, give us a call and we’ll send you one. We’ll even send you our latest Instrument Guide while we’re processing your application.

So join us as we celebrate a quarter of a century of service and quality. Because you get more than just an instrument when you rent with Leasametric.



 **LEASAMETRIC**  
INSTRUMENT RENTAL DIVISION

**1-800-553-2255 ext. 100**

(In Canada 1-800-268-6923)

With offices and inventory centers in Canada, France and Germany.

MetriCard is a service mark and trademark of Leasametric Instrument Rental Division.

Printed in USA

## COVER STORY

bundled in software utilities so users can configure memory above 640K bytes, in accordance with the Lotus/Intel/Microsoft and AST Research, Inc. expanded memory specifications (EMS).

Wyse is bundling into all its modular systems a number of features that are otherwise available for personal computer users piecemeal from a variety of third-party vendors. For example, a standard part of the system software is a disk-caching utility that the company claims speeds up disk operation by 40 percent to 50 percent by mirroring the most frequently used areas of the drive in main memory.

Version 3.2 of the MS-DOS operating system, as well as GW BASIC, come with all Wyse personal computers. But Wyse has enhanced MS-DOS with an on-line Help menu that lists command parameters, gives examples of their uses and tells why each command is necessary or useful.

To further distinguish itself within the herd of personal computer vendors, Wyse has added a dash of spice to the outward appearance of its latest systems. All four come with a liquid crystal display on the front panel that can be programmed for a number of uses. The LCD can display the date and time of day, as well as the operating speed of the processor, the disk drive performance and other system activities. Among other things, Wyse is pitching the LCD at system integrators as a way to configure a system without having to attach a monitor.

### Putting up a good front

Wyse is also offering a \$30 style kit with which OEMs and VARs can customize the appearance of the systems. The kit includes a cable covering for the back panel, a platform for mounting the chassis in a tower configuration and a choice of red, yellow or blue buttons and jacks. Wyse is also providing two packaging schemes that change the chassis color, louver design and LCD position in order to differentiate the systems sold through distributors.

Wyse officials say the modular personal computers will allow the company to address a broad set of cus-

| LOOKING AT WYSE'S MODULAR APPROACH TO PCs |         |         |                |                |
|-------------------------------------------|---------|---------|----------------|----------------|
| Feature                                   | WY-2108 | WY-2112 | WY-2214        | WY-3216        |
| CPU/speed                                 | 80286   | 80286   | 80286          | 80386          |
| Speed (MHz)/wait states                   | 8/1     | 12.5/1  | 12.5/0         | 16/0           |
| Maximum RAM on CPU (M bytes)              | 1       | 1       | 1              | 24             |
| <b>Expansion slots</b>                    |         |         |                |                |
| 8-bit                                     | 2       | 2       | 3(2 half-slot) | 3(1 half-slot) |
| 16-bit                                    | 5       | 5       | 6              | 6              |
| <b>Mass storage slots</b>                 |         |         |                |                |
| half-height                               | 3       | 3       | 3              | 3              |
| full-height                               |         |         | 1              | 1              |
| Power supply (watts)                      | 190     | 190     | 220            | 300            |
| Base price (\$)                           | 1,900   | 2,300   | 2,800          | 3,500          |

tomers. The smaller WY-2108 and WY-2112 will be aimed at the general office-automation market, which Wyse says will reach \$19 billion this year. The more powerful WY-2214 and WY-3216 will go to OEMs who provide platforms for such applications as CAD/CAM, file servers and multiuser systems.

To help resellers reach those latter users, Wyse is introducing with the personal computers a \$799 add-in board with eight intelligent serial ports. The WY-995 board takes up a single slot and has eight RJ-11 connectors on the back. It comes with all the cabling and DB-25 adapters necessary to attach data terminals or other serial peripherals, such as modems and printers. Continuous data can be transferred over all channels at 38.4K baud or in a burst mode over a single channel at 76.8K baud.

The WY-995 comes with 48K bytes of dual-ported static RAM as well as MS-DOS diagnostics and device drivers for the XENIX multiuser operating system.

With this onrush of equipment, say industry analysts, Wyse is positioning itself well for its next spurt of growth. Indeed, some contend the company has no choice but to diversify its product line.

"It's a great move and one they have to make," says Bruce Lupatkin, an analyst with Hambrecht & Quist, "The market is sleepy for terminals. PCs are where the action will be."

Wyse's diversification in personal computers will allow it to use the same successful mix of distribution channels that it does for terminals, according to analyst Dan Reeve of Cowen & Co., a Boston investment service. Along with that, Reeve says, the company's acquisition last year of Amdek Corp., a leading retail supplier of PC-compatible monitors, will allow Wyse to leverage its way into the retail business without making a big marketing investment in brand awareness. Although Wyse officials have not yet said so, a line of Amdek personal computers built around the modular architecture is sure to follow its OEM machines. □

### FACT FILE

Wyse Modular System Architecture

#### Wyse Technology

3571 N. First St.  
San Jose, Calif. 95134  
(408) 433-1000

Circle 474

\*\*Line of IBM Corp.-compatible personal computers that can be configured with either Intel Corp. 80286 or 80386 processors at various clock speeds.

\*\*Systems feature passive backplane architecture. CPUs reside on add-in boards to maximize configuration options.

\*\*Backplane accepts combinations of standard 8-bit and 16-bit add-in boards. Chassis available with either seven or nine expansion slots.

\*\*Optional Wyse WY-995 interface card allows up to eight terminals or other serial devices to be attached via a single expansion slot.

CR7

- Power
- Dist
- Communications
- Fault
- Battery

# THE NCR TOWER 32/800. BUILT TO GET YOU INTO BIG BUSINESS.

We gave our engineers a tall order.

Build a bigger, better NCR Tower® to take resellers up to the biggest, most lucrative accounts. With the power and connectivity to tackle the most complicated tasks. But without sacrificing the open systems architecture, upward compatibility and reliability that have made the Towers such a power for margin-minded VAR's worldwide.

Well, the bright minds in the lab didn't let us down.

Introducing the NCR Tower® 32/800. Its ingenious architecture lets you configure multiple processors dedicated to fit your customers' specific needs. If a customer needs more number-crunching power, you can add 68020-based applications processors, up to a maximum of four. For more connectivity, you can mix and match multiple 68010-based file, terminal or communications processors that support all major protocols. And connect up to 128 users.

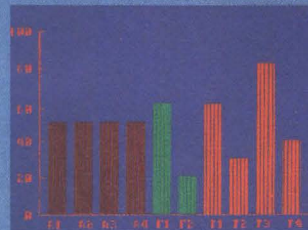

*An Activity Analyzer tracks system activity, finds bottlenecks, and tells you when and where to add power or memory.*

*The Tower family of upwardly compatible UNIX supermicros.  
Tower 32/400 (1-16 users),  
Tower 32/600 (8-48 users),  
Tower 32/800 (32-128 users).*

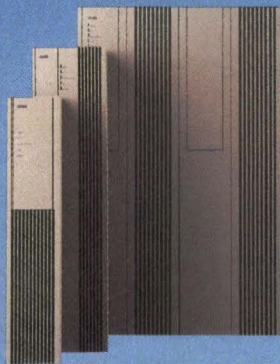

Of course, it takes smarts to control architecture so advanced, so we distributed an enhanced UNIX™ System V™ operating system to give each processor the power to do its own job most effectively. And help keep the system at peak throughput.

And we didn't limit high intelligence to the inside. The Tower 32/800 comes in a compact, modular unit that's nearly cableless. A snap to upgrade or service.

All of which make the Tower 32/800 the most versatile and configurable computer of its kind. And the smartest.

From a rock-solid \$4.9 billion company with more than 20,000 service personnel in 700 locations. And one of the most complete VAR support programs in the industry.

The NCR Tower 32/800.

If you have the heart to go after big business, this Tower has the intelligence to take you there.

Tower is a registered trademark of NCR Corporation. UNIX and Systems V are trademarks of AT&T Bell Laboratories. Specifications subject to change. Your NCR sales representative can provide the latest information.

## THE NCR TOWER. A SMART FOUNDATION TO BUILD ON.

NCR Corporation, USG-1, Dayton, OH 45479. Nationwide (800) CALL NCR.

CIRCLE NO. 21 ON INQUIRY CARD

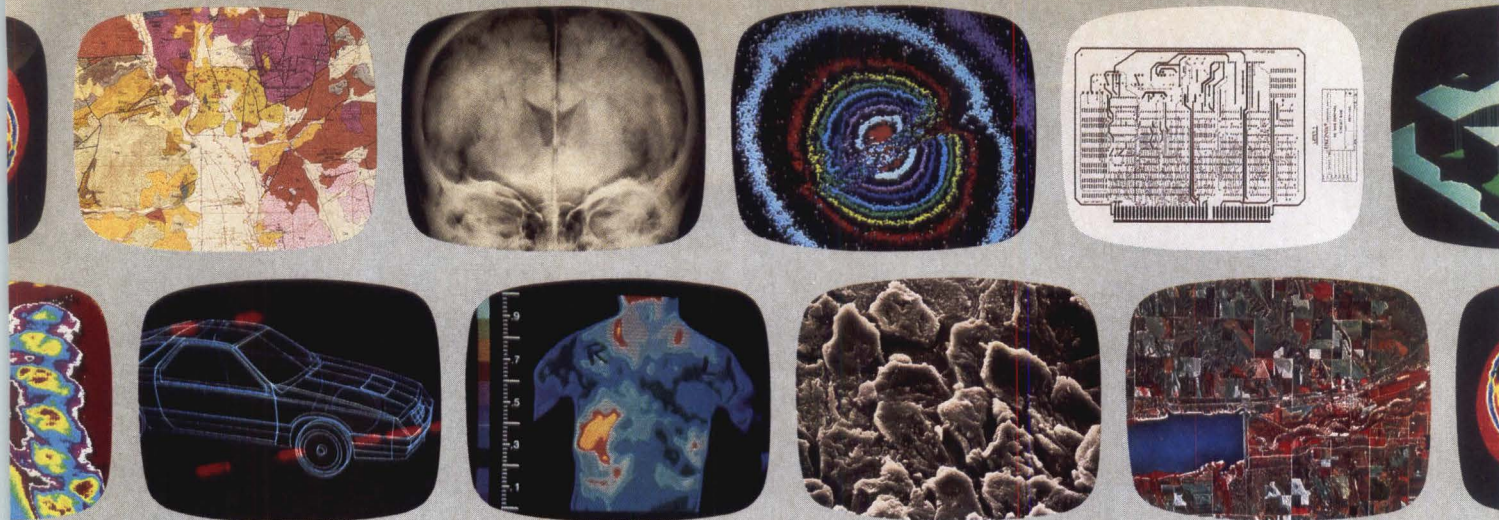

# Imagine what you could do if your computer could see.

Imagine the possibilities when your system can provide the flexibility of variable resolution up to  $4K \times 4K$  for demanding applications. Imagine that the system can reproduce over 16 million colors.



Eikonix high performance digital imaging cameras convert stationary pictures and objects into digital form.

There's no need to imagine if your systems incorporate the EIKONIX high-resolution digital imaging cameras.

Whether you choose the new EIKONIX 1000 for its self-contained electronics, the Series 78/99 for its superb color capabilities, or the Series 850 for unsurpassed resolution, you are providing your end users with some of the highest quality, highest performance digital imaging cameras commercially available. All this at an affordable cost.

EIKONIX is a Kodak company, which is your assurance of a commitment to excellence in product quality and customer support.

Give your systems a whole new point of view. Whether the application is color graphics, medical, AI, CAD input, scientific or any other that requires high-resolution digitization of a stationary image or object, call us at (617) 275-5070. Or write to us at EIKONIX Corporation, Digital Imaging Products Group, 23 Crosby Drive, Bedford, MA 01730. TELEX: 951231.

**EIKONIX®**  
A KODAK COMPANY

CIRCLE NO. 22 ON INQUIRY CARD

## PRODUCT SPOTLIGHT

# Pyramid's RISC-based superminis afford a multiprocessor approach

Mike Seither, Senior Editor

Pyramid Technology Corp. has this month doubled the punch of its Series 9000 superminicomputers with its most powerful systems yet—three- and four-processor models that can operate at between 19 and 25 million instructions per second (MIPS).

Along with the introduction of models 9830 and 9840, Pyramid also has expanded its communications horizons by offering access to IBM Corp.'s 3270 SNA (Systems Network Architecture) environment. At the same time, the Mountain View, Calif., company has brought out an ANSI 85 COBOL compiler, optimized for its reduced instruction set computer (RISC) architecture. With those offerings, Pyramid hopes to bolster its growing presence in the commercial marketplace, especially for large database applications.

According to analyst George Weiss of The Gartner Group Inc., a Stamford, Conn., market research outfit, Pyramid is repositioning itself between two ends of the data-processing world. "Their niche will be to act as a file server for workstations and as an extractor of databases tied to mainframes," says Weiss. "It's going to be important for them to talk about connection between those two tiers and to provide tools like SQL (structured query language) interfaces to bring data into their environment."

The new SNA connectivity goes hand-in-hand with a recent announcement that Pyramid will couple its superminicomputers with workstations manufactured by Sun Microsystems Inc., a Mountain View neighbor.

Pyramid has had some success selling into the commercial marketplace since it first introduced systems in 1983. But many of Pyramid's installed base of 550 computers have been used for software development. One reason for that is the company's

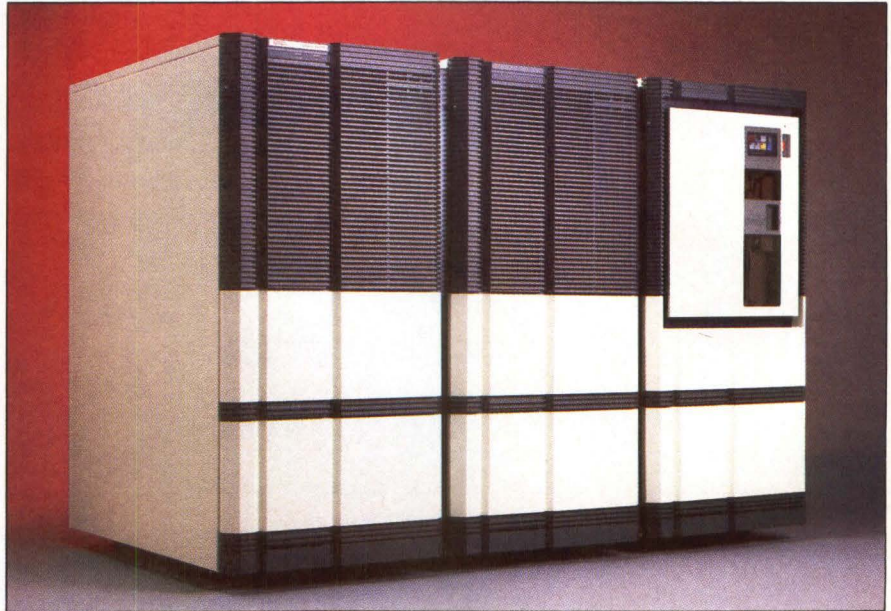

**Pyramid Technology's** Series 9000 superminicomputers now come in three- and four-processor versions and are object-code compatible with all previous Pyramid systems.

OSX operating system, a dual port that allows users to easily switch between both AT&T Co.'s UNIX System V and the Berkeley UNIX Version 4.2.

Pyramid's latest offerings round out the Series 9000 line. Last November the company brought out the one-processor 9810 and the two-processor 9820. Now, the 9830, with three CPUs, and the 9840, with four CPUs, establish the high end of the series. Using Digital Equipment Corp.'s VAX-11/780 as a 1-MIP baseline for comparison, the Series 9000 offers incremental performance increases of 7 MIPS, 13 MIPS, 19 MIPS and 25 MIPS, according to Pyramid product manager Tom Stuart. Moreover, all of the company's computers, including the earlier 90X, 98X and 98XE, are object-code-compatible, allowing applications written for any system to run on all others, without a compiler.

A 9830 in a standard configuration sells for about \$400,000. A similarly configured 9840 costs \$490,000. For

that, buyers get a three- or four-CPU system with 32M bytes of main memory, 32 RS232 ports, a 470M-byte disk drive, a half-inch tape drive, a system console, a built-in Ethernet, an OSX 32-user operating system license and a one-year warranty.

### More mass to store

Besides adding more CPUs, Pyramid has also doubled both the user support and the mass storage of the entire Series 9000 line. Users can now attain a maximum 512 attached terminals by adding 16-port intelligent-terminal processors, up to a limit of 32. Total disk-drive capacity now stands at 29G bytes, up from 15G bytes on earlier systems. Main memory, available in 4M-byte or 16M-byte modules, still tops out at 128M bytes.

In the Series 9000, Pyramid has somewhat refined its original RISC architecture. RISC uses transistor to transistor logic, placing 528 overlapping 32-bit registers inside the proprietary CPUs. The intensive use of reg-

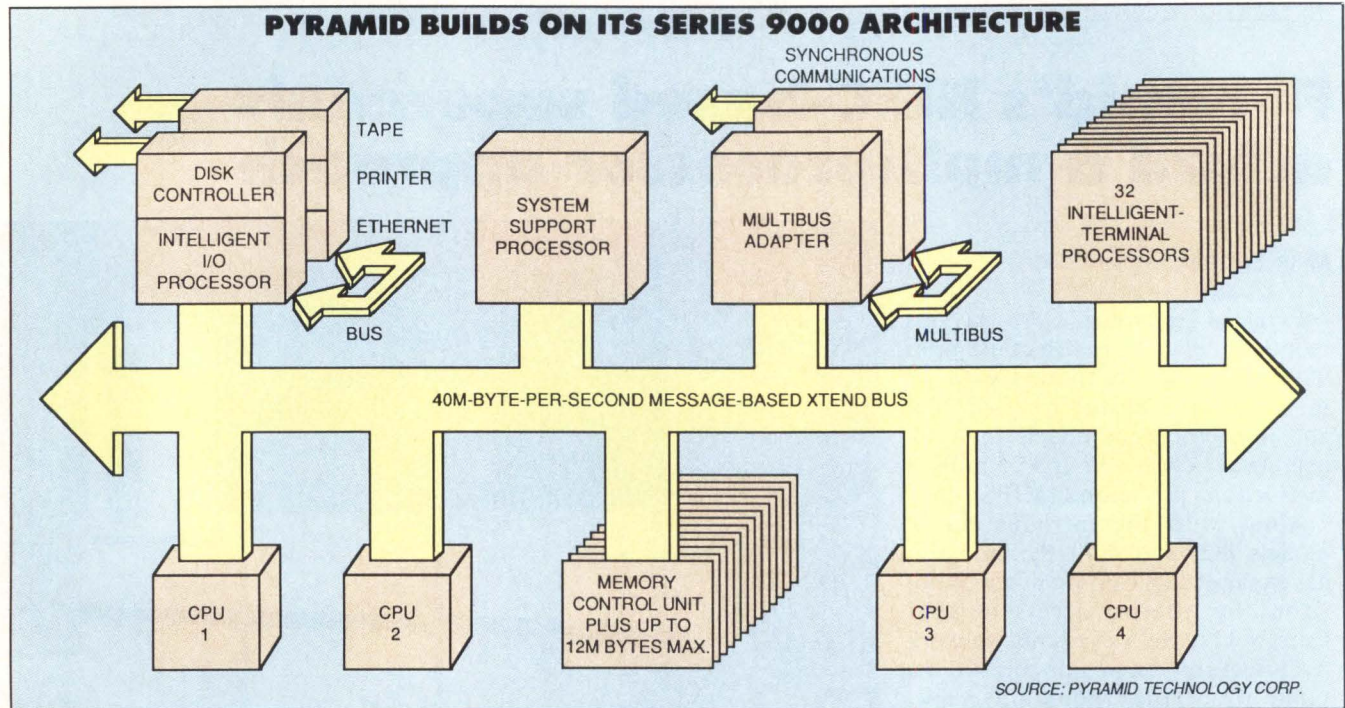

**Pyramid's UNIX-based 9840 superminicomputer features four RISC processors. Multiple intelligent terminal processors can support up to 512 users. Disk capacity for all Series 9000 systems has doubled to a maximum of 29G bytes.**

isters and a simplified set of 128 instructions allow the CPUs to execute most pipelined instructions in a single clock cycle. To further increase the number of single-cycle executions, Pyramid has installed prefetch and branch-prediction features.

In addition, Pyramid has doubled the instruction and data caches to

32K bytes and 64K bytes, respectively. "Database applications that, before, just exceeded the cache limits now have an extra margin," explains Pyramid's Stuart.

Databases are a key to Pyramid's marketing strategy. The Series 9000 supports most major databases, including those from Britton Lee Inc.,

### Third-party resellers critical to Pyramid's success

Concentration on database applications is only one part of Pyramid's strategy to broaden the appeal of its RISC (reduced instruction set computer) machines. In March, the company entered the Pick System world by signing an agreement with VMark Computer, Natick, Mass. Pyramid will license VMark's Pick-based Universe operating system, which runs under Pyramid's OSX. That will give Pyramid users access to applications that were previously unavailable to them, like distribution and manufacturing.

Pyramid also plans to step up its activity in the reseller channel. Now, about 40 percent of the company's sales come from reseller and OEM agreements, while the majority are direct. Richard Luccier, who has recently joined the company as president, wants to reverse those figures. To get there, Pyramid has launched a program to identify resellers who want to run their vertical-market applications on more powerful machines. Luccier expects to have at least two dozen resellers on board before the year's end. Says Kathleen Hurley, an analyst with Dataquest Inc., San Jose, "Alliances with

third-party software vendors are critical for Pyramid. Without them they won't sell many products."

Pyramid also has its work cut out for it elsewhere. In its last fiscal year, ending September 1986, the company posted a \$2 million loss on sales of \$38.6 million. Luccier attributes the losses to bloated inventories and a poor market. However, he believes the company is now breaking even because of internal cost-cutting measures. Cost cutting's being done, he adds, without reducing the number of employees or cutting back on the company's \$10 million research and development budget.

How well Pyramid spends its R&D funds may have a large impact on its future, says analyst Geroge Weiss of market researcher The Gartner Group of Stamford, Conn. He notes that Pyramid was slow in bringing its three- and four-processor system to market. "The mid-range of the mini market was once a golden egg," he says. "But now, the competitive pressure is intense, and product life cycles are shrinking."



Los Gatos, Calif.; Oracle Corp., Belmont, Calif.; Relational Technology Inc., Alameda, Calif.; Informix Software Inc., Menlo Park, Calif.; and Unify Corp., Lake Oswego, Ore. To maintain its position in that market, Pyramid is trying to ensure that its systems have the muscle to access large amounts of data.

To that end, Pyramid recently brought out a virtual disk facility which resides in the operating systems and allows mapping between logical and physical disk volumes—something IBM and vendors of other large systems have been doing for some time. With a virtual disk, data can be split over several disks as one logical file. A logical database can also reside on several drives. By splitting up the database, and allowing the information to be reorganized, the virtual disk can help reduce bottlenecks caused by “hot spots,” or areas of the disk holding information that is frequently accessed. Hot spots can also be assigned their own spindles

#### FACT FILE

##### Pyramid Technology Corp.

1295 Charleston Road  
Mountain View, Calif. 94039-7295  
(415) 965-7200

Circle 473

\*\*The 9830 and 9840, three- and four-processor superminicomputers, respectively, based on Pyramid's RISC architecture.

\*\*Maximum configuration supports 512 terminals and 29G bytes of mass storage capacity.

\*\*Systems operate under Pyramid's OSX operating system, a dual port of AT&T Co.'s System V Release 3 and Berkeley UNIX Version 4.2.

\*\*Optimized ANSI 85 COBOL compiler, and IBM Corp. communications via 3270 SNA, now available with Series 9000 systems.

and heads, thereby further reducing the possibility of information log-jams, says William Gimple, Pyramid's vice president for systems technology.

Pyramid claims it is the only UNIX vendor to thus far offer the capabilities of a virtual disk. □

#### FAMILY PORTRAIT

**IBM's new Personal System / 2** series consists of (from left) models 30, 50, 60 and 80. The \$1,695 model 30 incorporates Intel's 8086; models 50 (\$3,595) and 60 (\$5,295), the 80286; and model 80 (\$6,995), the 80386. Model 30 boasts twice the performance of the PC/XT; models 50 and 60, twice the performance of the PC/AT; and model 80, more than triple the performance of the PC/AT. All models will run under the new OS/2 operating system due in the fourth quarter. Starting next month, *Mini-Micro Systems* will run a multiple-article series on the PS/2 family, quoting analysts, VARs, system integrators and vendors.

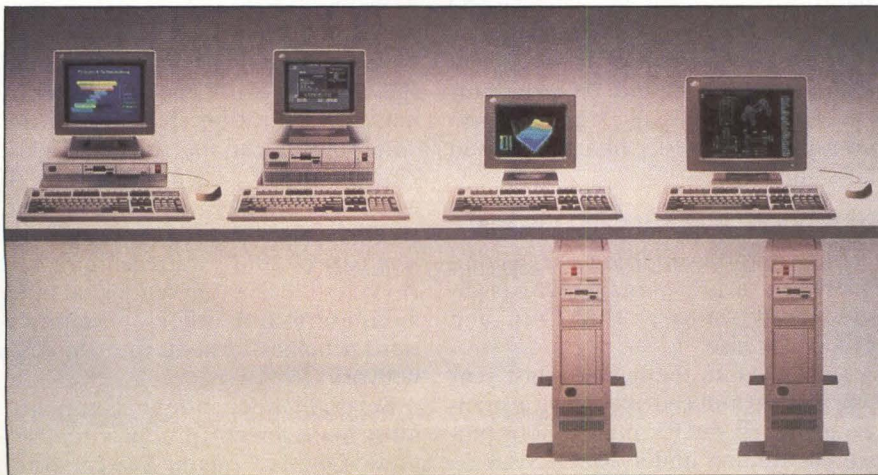

# 16 MB VMERAM

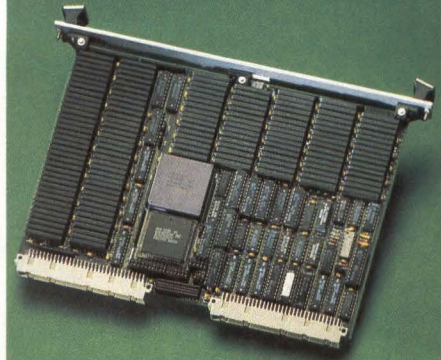

## VMEbus Memory Combining 16 MB Capacity and Error Detection and Correction

The VMERAM/16 is the highest density VMEbus-compatible memory available anywhere, with the added bonus of EDC reliability. Clearpoint's unique EDC chip set features full single bit error correction and double bit error detection, with performance equal to or surpassing parity memory. The VMERAM/16 uses advanced ZIP megabit DRAMs to achieve the unprecedented capacity of 16 MB. It also supports block mode transfers (BMT) and unaligned transfers (UAT), as well as 24 and 32 bit addressing. All Clearpoint memory boards come with a lifetime warranty and a 24-hour repair/replacement policy.

#### Write or call for

- VMERAM User's Manual
- Clearpoint's 80-page Designers Guide to Add-in Memory
- The 20-page Add-in Memory Catalog and Selection Guide



**CLEARPOINT INC.**

U.S.A. 1-800-CLEARPT  
Telex: 298281 CLEARPOINT UR  
Massachusetts 617-435-5395/435-2301  
Europe Clearpoint Europe  
Telex: 71080 ACT H NL Tel: (31) 23-256073  
Asia EPRO Ltd. (Hong Kong)  
Telex: 51853 JUNWI HX Tel: 3-721330

See us at INDEX Europe, Booth #141

**CIRCLE NO. 23 ON INQUIRY CARD**

# INTERPRETER

## NETWORKS

# System integrators jump into network management

**James F. Donohue**  
Managing Editor

It should come as no surprise, but system integrators have discovered there's money to be made in network management. The reason: Money, or the saving of it when setting up and operating a network, is the chief worry among most communications customers.

"It's a very hot topic with telecomm users," says Don Wallace, project manager for Teknekron Info-switch Corp., a system integrator and consultant in Richardson, Texas. "A telecomm network is very expensive, and users have no way to stay on top of the costs. Everything is manual, so they review the costs on very long intervals, typically a year," Wallace points out. "They want to do better than that."

Christopher A. Walker, account manager for Omega Datum Corp., a system integrator in Towson, Md., says, "Networking can solve a lot of problems, and certainly we're going to be involved with it." Vendors of network management equipment have a long way to go, he observes. "Most of the things out there are no more than file-swap mechanisms. We'd like to see things operate at a little more elevated level."

Computer networks are growing fast (about 35 percent a year) and have become hugely expensive (taking up to 60 percent of many computing budgets). Yet, selecting and implementing a network management system is not easy, because vendors offer so many incompatible products and so many conflicting protocols. "There's a mishmash of tools out there, but nobody seems to have it integrated to make the whole process

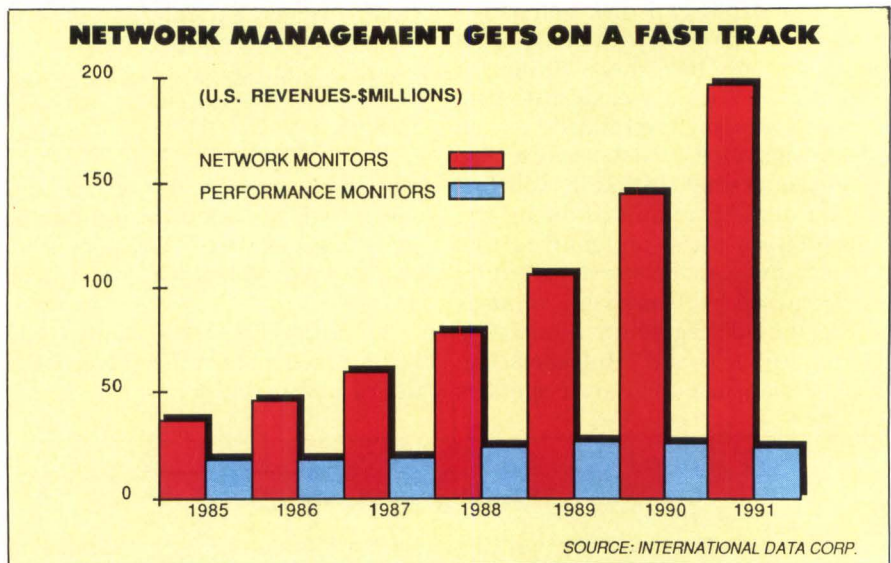

**Revenue growth** for performance monitors will slow because vendors increasingly will include that function in network monitors. Approximately one-third of revenues comes from upgrades of existing equipment.

run very smoothly," Wallace says.

Despite this confusion, vendors and system integrators agree on what they want network management products to do. The products ought to monitor who's using the network and when, and where the data is going; they should collect and display alarm signals; diagnose and fix problems (intelligently if possible); and perform administrative tasks like billing and cost allocation.

### Network history: IBM and the rest

Like almost everything else in computers, network management is divided into two parts: IBM Corp. and everybody else.

IBM got into the business last year when it introduced Netview, a management scheme for multivendor networks running under IBM's Systems

Network Architecture (SNA). Later, IBM came up with an enhancement, Netview/PC.

Netview brought under one roof several of Big Blue's alphabet soup of network protocols: Network Communication Control Facility (NCCF), Network Logical Data Manager (NLDM), Network Problem Determination Application (NPDA), Virtual Telecommunications Access Method Node Control Application (VNCA) and Network Management Productivity Facility (NMPF). Netview/PC was part of IBM's outreach program: It makes it easier for vendors of other computers and other communications schemes to hook into the SNA network.

Several independent companies offer management products for Netview. One is Cincom Systems Inc.,

## NETWORKS

Cincinnati, with Net/Master Management Component. A software solution to monitoring and control, Net/Master checks error messages, captures statistics and prioritizes alerts for network managers. Another company with products for Netview is Timeplex Inc., Woodcliff Lake, N.J. Specializing in monitoring the physical aspects of networks, Timeplex supports a software product called Link/View with which it ports many of its systems to run on Netview.

### Two segments of product

In the IBM world, as well as in the non-IBM world, vendors tend to divide their products into two segments. These are: (1.) products that monitor the network's physical aspects—multiplexers and modems (what Victoria Duckworth, product manager at Cincom, calls the "wires and pliers end;")—and (2.) products

that monitor the performance of the network, i.e. the movement of data over the wires.

Computer network monitoring makes up a small industry now, about \$83 million in U.S. sales, according to International Data Corp. (IDC), the marketing information concern in Framingham, Mass. But forecasts are for rapid growth, almost threefold to \$224 million in 1991.

Price cuts spurred by competition are behind much of this growth, says Kathryn Korostoff, senior market analyst at IDC. "Three years ago you could buy a good network management system for \$250,000 to \$350,000," she says. "Today, it will cost you about \$150,000, and you can probably get one for less."

One such system that costs a lot less is offered by Codex Corp., Canton, Mass. Called the 9300 Series, it targets smaller networks (up to 400

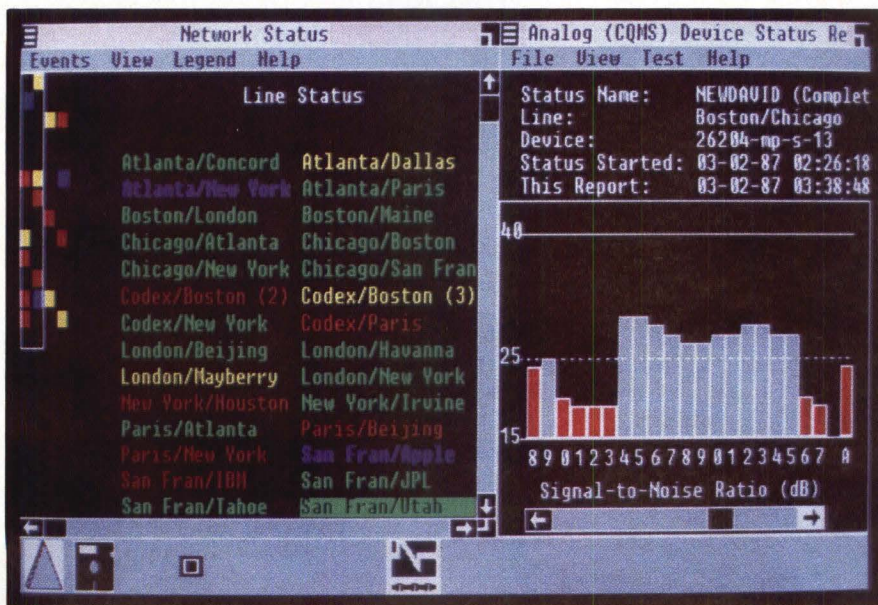

**Line-status monitoring** gets color coding in Codex's 9300 Series network management system: green for normal conditions; yellow, degrading conditions; red, serious alarms; blue, acknowledged alarms. Windowing permits operators to handle several jobs at once.

# 16 MB for PC/RT™

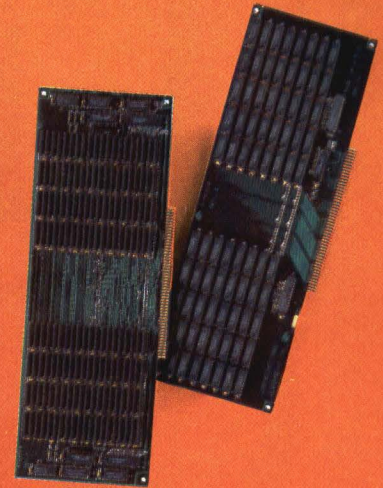

## 4 and 8 MB Expansion Cards Fully Compatible with the New IBM PC/RT

The RTRAM Series continues with the first 100% PC/RT-compatible memory for the new generation Models 6150 and 6151. Clearpoint—the first vendor of compatible memory for the original RT—has upgraded the design to support the higher performance RT. Memory cycle time has been reduced from 290 to 180 ns and access time from 170 to 100 ns. The new PC/RT offers improvements of 3.6X in processor performance, up to 40X in floating point performance, and 4X in data rate. **Memory is more critical than ever to realizing the full potential of the new RT.**

Clearpoint offers both 4 MB and 8 MB capacity cards, to allow users to configure 16 MB systems with two expansion slots. Other features are on-board interleaving and low power consumption. All Clearpoint memory comes with a lifetime warranty and a 24-hour repair/replacement policy.

### Write or call for

- RTRAM User's Manual
- Clearpoint's 80-page Designers Guide to Add-in Memory
- The 20-page Add-in Memory Catalog and Selection Guide



## CLEARPOINT INC.

U.S.A. 1-800-CLEARPT  
 Telex: 298281 CLEARPOINT UR  
 Massachusetts 617-435-5395/435-2301  
 Europe Clearpoint Europe  
 Telex: 71080 ACT H NL Tel: (31) 23-256073  
 Asia EPRO Ltd. (Hong Kong)  
 Telex: 51853 JUNWI HX Tel: 3-721330

PC/RT is a registered trademark of International Business Machines Corporation.  
**CIRCLE NO. 24 ON INQUIRY CARD**

# THINK GIG.

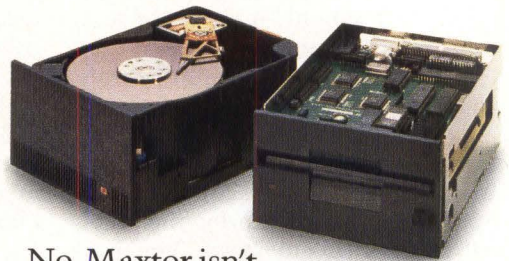

No, Maxtor isn't announcing a gigabyte drive.

Not yet.

But consider this. In just four years, we've increased capacities in our 5 1/4-inch disk drive families from 85 MB to 800 MB.

So can gigabytes be far behind?

That's why now's the time to start thinking about what you could do with a gigabyte drive from Maxtor. Like open up new applications. New markets. And a devastating competitive edge.

But then, you can get those advantages from every Maxtor drive. Because each one offers the highest performance, highest capacity and lowest cost-per-megabyte in its class.

So don't just think gig.

Think Maxtor.

Maxtor Corporation, 211 River Oaks Parkway, San Jose, CA 95134, (408) 432-1700, TELEX 171074.

Sales offices: Austin (512) 345-2742, Boston (617) 872-8556, Orange County (714) 472-2344, New Jersey (201) 747-7337, San Jose (408) 435-7884, Woking, England (44)/4862-29814.

## Maxtor

Distributed by: Anthem Electronics, Inc., Lionex Corporation, Pioneer-Standard Electronics, Inc., Quality Components, Inc., Storex Corporation.  
© 1987 Maxtor Corporation.

CIRCLE NO. 26 ON INQUIRY CARD

## NETWORKS

nodes) and starts at \$11,500. The user is prompted on line status through color coding and can monitor several jobs simultaneously via windows.

The companies selling products that monitor the physical part of the network have the biggest share of sales: \$61.5 million this year. These include Codex; Timeplex; AT&T Co.; Case Communications Inc., Columbia, Md.; General DataComm Inc., Middlebury, Conn.; Infinet Inc., North Andover, Mass.; Infotron Systems Corp., Cherry Hill, N.J.; Paradyne Corp., Largo, Fla.; and Racal-Milgo Information Systems Corp., Fort Lauderdale, Fla.

### Checking with 'sidebands'

Typically, these companies sell products that do their monitoring over "secondary" channels, or "sidebands," which use a frequency (usually 150 Hz) that differs from the frequency of the channels carrying the main network traffic. That way, the monitoring doesn't interfere with the work traffic.

However, this technique presents problems. The vendors use their own very private conventions for the sidebands. "Everybody has a proprietary protocol, which they protect under the threat of death," says Stephen Mank, manager of product marketing at Codex. "That's how we differentiate ourselves from our competitors."

A result is that a vendor's monitoring product works only with that vendor's modems and other network gear. To accommodate customers with foreign equipment, vendors sell "wrap" or "wrap-around" devices that plug into the network control ports of the foreign devices.

But even the vendors admit these wrap products don't work well. "They can't read the analog portion of the devices," Mank explains. They miss such conditions as jitters, distortions and dropouts, which are key heralds of trouble coming on a line.

System integrators say they have no efficient way to deal with this incompatibility problem. If protocols can't

monitor what's happening to certain devices, the system integrator often is reduced to using primitive manual methods to fix a failure. When a modem fails at the University of Maryland at Baltimore, for example, Bill Reynolds, director of computer operations, tries to figure out what device has failed and fix it with a spare. Often, he says, "We can't find the problem by analysis and have to swap out components to try to isolate what's wrong."

One system integrator in California notes that the way he knows that a modem has failed is "when one of our customers calls up and screams."

Incompatibility of monitors and foreign devices on the network is an issue system integrators say vendors must address quickly. "That's one of the issues that's been an inhibitor to effective network management," says Omega Datum's Walker.

### Tops among performance watchers

The second segment of the network management business—companies that sell products that check on the performance of the networks—is led by Avant-Garde Computing Inc., Mount Laurel, N.J., and Tesdata Systems Corp., Herndon, Va. IDC says these two share more than half of this market segment's \$21 million in 1987 sales. Other vendors include Cincom; Dynatech Packet Technology Inc., Alexandria, Va.; Ocean Data Systems, Inc., Rockville, Md.; and T-Bar Inc., Wilton, Conn.

Increasingly, vendors are combining the monitoring of the physical and performance aspects of networks. Infinet monitors both functions and integrates them in a relational database that supports administrative functions. Infotron does the same with its Integrated Network Manager.

Customers have begun to demand higher levels of sophistication in network management. They no longer are satisfied with products that "fix" problems by predefined (preprogrammed) means: for example, by rerouting traffic around a failed

# Clearpoint

Single Slot  
2 MB Capacity Memory  
for Computer  
Workstations

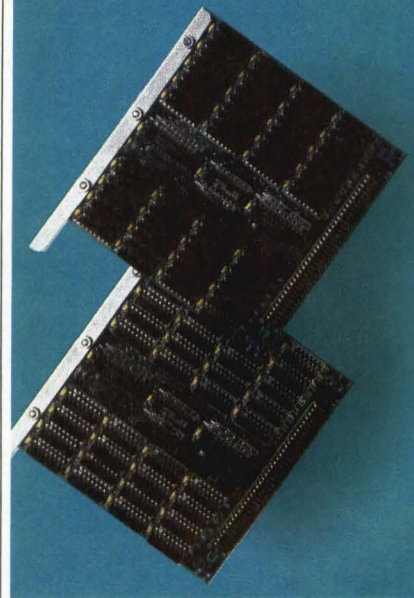

## ■ Apollo DN3000

The DN3000 memory offers 1 or 2 MB capacities on a single card. Completely hardware/software compatible with the Apollo DN3000 series of computer workstations, it supports the 32-bit data bus with byte, word, longword and unaligned transfers.

Access time is 120ns, achieving identical performance to the Apollo memory. However, by using zig-zag in-line packaged 256K dynamic RAMS (ZIP DRAMS), the board delivers twice the density per slot.

The DN3000 is lifetime warranted\* and is supported by a 24 hour before repair/replacement policy.

*Write or call for our new designer literature packages.*

- Clearpoint's 80-page Designers Guide to Add-in Memory
- The 20-page Add-in Memory Catalog and Selection Guide

\*All Clearpoint memory products are warranted for life.



**CLEARPOINT INC.**

99 South Street • Hopkinton, MA 01748

U.S.A. 1-800-CLEARPT  
Telex: 298281 CLEARPOINT UR

Massachusetts 617-435-5395/435-2301

Europe Steprade, Ltd. (Netherlands)  
Telex: 71080 ACT H NL Tel: (31) 23-256073

Asia EPRO Ltd. (Hong Kong)  
Telex: 51853 JUNWI HX Tel: 3-7213300

Apollo DN3000 is a trademark of  
Apollo Computer, Incorporated

**CIRCLE NO. 25 ON INQUIRY CARD**

## NETWORKS

### Will IBM junk SNA?

Are you kidding? There's not a chance in the world, says just about anybody you ask.

First, there's all that money IBM Corp.'s already spent on SNA—Systems Network Architecture, Big Blue's hierarchical network operating system. Michael D. Zisman, chairman, Soft-Switch Inc., King of Prussia, Pa., says IBM has had 15,000 people working on SNA in one form or another for 15 years at its research operation in Raleigh, N.C. That's an investment which by now runs into the billions of dollars in just salaries and facilities costs.

And then there's all those customers worldwide who own IBM mainframe computers and use SNA to network them with other IBM computers. IBM has 85 percent of worldwide mainframe installations, says The Yankee Group, a Boston think tank. As far as IBM is concerned, SNA both makes these customers happy and locks them into the color blue. "SNA is the single most important strategy IBM has today," says Howard Anderson, managing director of The Yankee Group.

Nevertheless, in the past couple of years, IBM found itself slipping between SNA and a hard place.

On one side was that enormous investment. On the other were all those blue-tinted customers who, suddenly, had become restless. They began telling IBM they wanted ways to connect into other people's computers and computer networks, especially into Digital Equipment Corp.'s computers and into its DECnet network system.

At about the same time, IBM's European customers said they wanted their computer networks to operate under a framework called Open Systems Interconnection (OSI), established by the International Standards Organization (ISO). To compound matters, DEC said it supported OSI and moved to make DECnet a subset of it.

If these customers didn't get what they wanted, says Anderson, they threatened "to consider other options, including OPC—Other People's Computers."

About this time, insiders say, IBM considered junking—or substantially revising, or "turning"—SNA. Better to lose a network operating system than the world's largest customer base.

Then IBM found a way off the horns of its dilemma. It formalized the Open Communication Architecture (OCA) it had been discussing with customers for years. With OCA, IBM allowed customers to attach the computers of companies like DEC, Hewlett-Packard Co. and Wang Laboratories Inc. to the IBM/SNA network—with a catch. You had to do it IBM's way.

"IBM specifies the rules by which you connect to their system," explains Dr. Kenneth Thurber, president of system integrator Architecture Technology Corp., Minneapolis.

It was a clever scheme. IBM clung to SNA, but made it easier for anybody to connect almost anything into it—while maintaining tight control over how users made the connections. In the process, says Soft-Switch's Zisman, SNA changed meaning from "Shall Net Attach" to "Shall Not Abandon."

Insiders say IBM is reconciled to a belief that, eventually, the world will be divided into SNA and OSI. And IBM understands that these two worlds will connect. More than that, IBM plans to use OSI as part of its sales strategy. "IBM sees OSI as an Esperanto, the gateway into non-IBM environments," says Victoria Duckworth, product manager, Cincom Systems Inc., Cincinnati, Ohio.

Says Thurber, "IBM's strategy is that SNA will become the de facto standard" for IBM networks. Then, he says, "IBM will build gateways to OSI."

modem in a way determined in advance by a programmer. Instead, they want systems with enough intelligence to figure out solutions for themselves.

"Networks have become too complicated for anybody to determine in advance what to do in every instance of a problem," says Mac Lewis, president of Computer Network Technology Corp., New Hope, Minn., a communications vendor specializing in

moving data among mainframe computers. "When you connect 10 to 20 Ethernets, how can you predefine how to fix everything?"

#### Easier said than done

To meet this demand, vendors are turning to one of the computer industry's most maligned product categories: artificial intelligence. Several companies are working on AI for network management—including Avant-

Garde, Case Communications and IBM. But, incorporating AI into network management is presently more talk than actual technology. Effective products, like expert systems that can replace human beings and make decisions as the need arises are seen to be years away. "It seems that there is an opportunity for artificial intelligence to be applied to this technology," Lewis says. "But I've not seen any of it implemented at this time." □

See us at #2701  
**COMDEX/Spring '87**  
June 1-4, 1987  
Georgia World Congress Center  
Atlanta, GA



Introducing the Mylex 386 system board... the ultimate in microcomputing power! It's the same size as an AT system board for easy integration or upgrade. Speed previously unattainable is now possible by utilizing a special section of memory (known as CACHE) to store the most frequently used code. The 386 is complete with ROM-based diagnostics and hardware setup. Backed by extensive documentation and technical support.

**The 386 features include:**

- Intel 80386 6/16 MHz Keyboard selectable.
- 1MB or 4 MB of 32 bit RAM on the system board.
- 64KB of 32-bit no-wait-state CACHE memory.
- BIOS by AMI.
- 6-16 bit slots & 2-8 bit slots.
- Battery backup for Clock/Calendar and Hardware Setup.
- Socketed for 80287 6/10 MHz coprocessor.
- Norton Rating 23.5.
- 1 year warranty.
- Made in U.S.A.

In stock at your authorized Mylex distributor.

Ask about our compatible display adapters.

ALL TRADE MARKS ACKNOWLEDGED

**mylex**® 5217 N.W. 79th Avenue, Miami, Florida 33166 • Toll Free: 1-800-446-9539 • In Florida: (305) 592-9669

CIRCLE NO. 27 ON INQUIRY CARD

Our powerful new computer architecture can put your competition on the defensive. Because when it comes to performance, there's no contest at anywhere near our price.

We're building a whole family of computers around our enhanced RISC architecture. The first member, the HP 9000 Model 840, gives you up to eight times the performance of the VAX 11/780\* For just \$81,500\*\*

That buys you a future, too. Our Precision Architecture affords complete software and communications compatibility from micros to mainframes. Unlike the VAX architecture, it lets you build around standards. For networking, operating system,

languages and data bases.

HP is also the first major vendor to combine real-time and the UNIX\*\*\* System V operating system. That opens up all kinds of possibilities in general purpose,

**HP PRECISION ARCHITECTURE GIVES YOU AN ALMOST UNEFAIR ADVANTAGE.** scientific, engineering and manufacturing applications. When you take on the competition

with the Model 840, you'll have the best people in your corner. HP's support has again been rated Number One overall, according to the 1986 Datapro Survey.

If you're considering a DEC system or a UNIX-based system, pick up the phone and call us at 1-800-566-1234, Ext. 160; in California, 1-800-441-2345, Ext. 160. Then you'll be ready to pick up the gauntlet.

*we never stop asking*

*"What if..."*

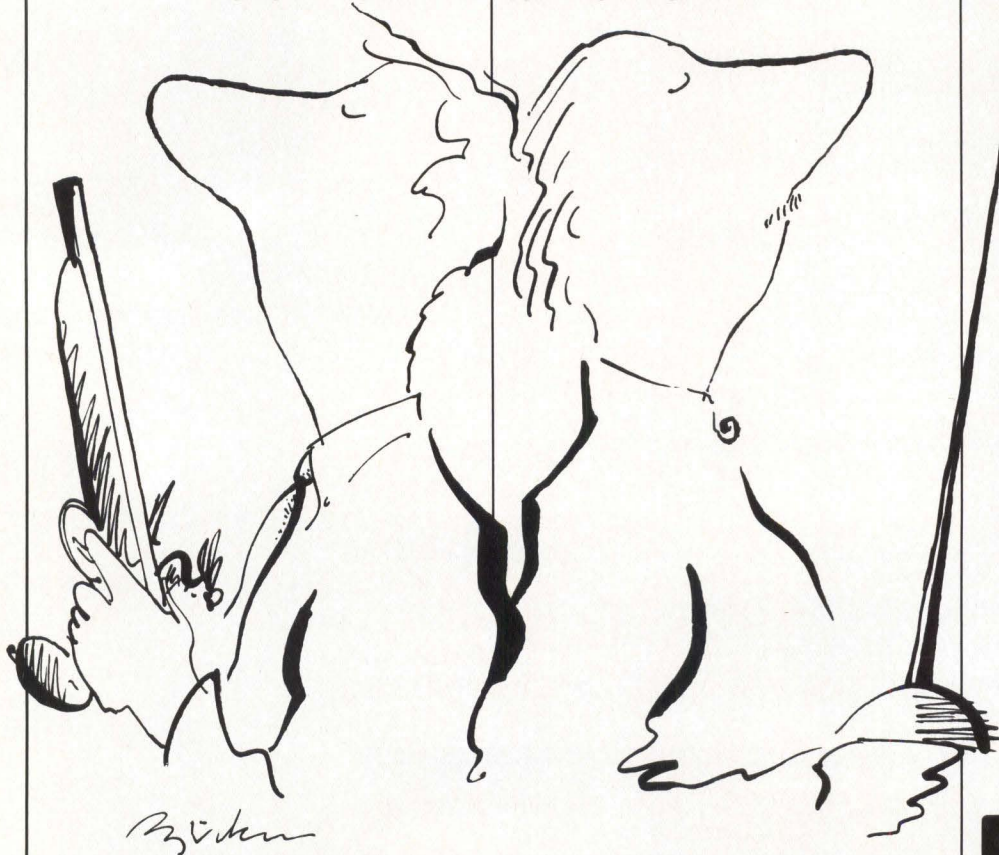

\*HP benchmarks. \*\*U.S. List Price. \*\*\*UNIX is a registered trademark of AT&T in the U.S. and other countries.

MS02701

CIRCLE NO. 28 ON INQUIRY CARD



## MEMORY TECHNOLOGY

## Bubble memory bursts into niche markets

Megan Nields, Staff Editor

When Intel Corp. introduced magnetic bubble memory (MBM) in the early 1970's, it was hailed as a replacement for conventional disk drive and mass storage media. Indeed, it seemed like the answer to a system integrator's prayers—a storage system with extremely high reliability, immunity to contaminants and resistance to shock.

However, MBM never really got off the ground. The cost per bit was, and is, relatively high for many engineering applications, and the component-fabrication process was complex. In addition, conventional rotating technologies were raising bit densities and lowering costs. As a result, MBM took on a narrower role than expected—primarily in niche markets such as satellite communications, factory automation and certain military applications. Although progress is being made in terms of falling cost per bit and improving yield rates, widespread commercial use of the technology does not appear to be on the immediate horizon. MBM may be here to stay but only in confined areas.

All in all, confusion seems to be the operative word in the bubble memory business today. Intel, once the leading U.S. manufacturer, has recently pulled out of the market, selling its MBM division to MemTech Inc., Folsom, Calif. Companies such as Hitachi America Ltd., Fujitsu Components of America (FCA) and Magnesys have different opinions about MBM's current applications and future.

Hitachi, now the leading international supplier of MBM, has been involved with the technology since 1970. The company's first MBM product, a 16K-bit device, was introduced in 1975. Further offerings included 1M-bit and 4M-bit versions, introduced in 1980 and 1984, respectively. They were marketed as gener-



### Magnesy's Removable Bubble Memory Storage Subsystems

come in 3 1/2- and 5 1/4-inch half-height drives, or in a two-cartridge VME industrial chassis (right).

al-purpose memory systems. The company's latest offering, the Picture Frame Coil, is a coin-sized, hermetically sealed edition of the 4M-bit unit that uses about 20 percent less power. It costs \$358 in quantities of 1,000 and is the smallest MBM device on the market today.

### MBM prices drop

Ed Klink, marketing development manager of Hitachi's Electron Tube Division, Schaumburg, Ill., feels that MBM is an important product for certain niche applications—such as industrial and factory automation, telecommunications and banking—that demand high reliability. According to Klink, military use of MBM is rising significantly and accounts for as much as 40 percent of the market. The company uses ion-implantation technology and a new magnetic circuit design to raise bit density and reduce the package size of MBM devices.

Klink says that the cost per bit of bubble memory has dropped fivefold since 1980, to average approximately 10 millicents per bit. He said he expects it to continue to fall because of higher yields and reduced manufac-

turing costs. Hitachi's 4M-bit device costs 6.2 millicents per bit, while the hermetically sealed version runs at 8.1 millicents per bit. He places the current worldwide market at about \$106 million and expects it to swell to \$135 million by 1987. Although Klink predicts that by 1990 more commercial markets will open up, he says that right now MBM is "way beyond engineers' and system integrators' comfort zone in terms of price." He suggests that, before MBM sells in significantly higher volumes, prices will have to drop considerably.

Jerry Houston, strategic marketing manager of Zitel Corp., Milpitas, Calif., places MBM costs at approximately \$800 per megabyte while a rigid disk drive might run from \$20 to \$60 per megabyte, depending on the size on the drive and its market. Houston, like Klink, feels that bit densities will have to increase, if MBM is to be at all cost-effective. Zitel makes customizable, conventional memory systems.

FCA, Santa Clara, Calif., also considers the bubble memory business to be a niche market for harsh-environment operations. General manager Jack Foster does not foresee widespread commercial use of MBM and feels that for many applications, such as desktop computing, it is too expensive—even unnecessary. He says that the company plans to introduce a 4M-bit device in the first quarter of this year. A 16M-bit product is in the development stages. Foster estimates FCA's current domestic market potential at about \$10 million and thinks that it will rise incrementally, rather than dramatically.

Magnesy's, of San Jose, is probably the only company dedicated exclusively to fabricating solid-state MBMs for integration into data-storage subsystems for extreme environments. Ted Wuerthner, Magnesys president, feels that bubbles are too expensive and too difficult to use when sold as components. He describes them in this form as "a \$2,500 answer to a \$500 problem." Magnesys' product consists of a compact, 3 1/2- or 5 1/4-inch removable data cartridge that fits into an electronic drive containing the

## MEMORY TECHNOLOGY

control circuitry. A VME industrial chassis version holds two cartridges. The company defines its subsystem as an application-specific product that provides permanent memory storage and is "infinitely customizable for the world outside of air-conditioned offices."

### Packaged as subsystems

Spokesmen at Magnesys feel optimistic about MBM's potential. Wuerthner estimates that the MBM market could be worth up to \$100 million annually in five years, if more manufacturers took the subsystem approach, which would allow for higher yield rates. The company plans to ship subsystems at a price of \$750 apiece in volume orders in the first quarter of this year.

Magnesys aims at four markets:

- Retrofitting of installed personal computers that use either flexible or rigid disks in industrial applications;
- VARs, who, Wuerthner says, resell 80 percent of all the IBM Corp. PCs in the industrial world;
- OEMs who put together process-control equipment;
- Military applications such as ground-based battle planning.

Magnesys subsystems are read/write units equipped with an integral small computer system interface (SCSI), making them plug-compatible replacements for disk drives with the same interface. Wuerthner states: "We recognized that users need tougher memory systems in severe environments due to the fragility of rotating memory or the limits of other technologies. Hence, the need exists for vertically integrated components and systems as cost-effective, solid-state memory devices that are rugged, reliable and removable."

Brad Jones, senior applications engineer for Targa Electronics Systems Inc., Ottawa, agrees that MBM will not be used for commercial applications until it is "a couple of generations ahead of where it is now," in terms of cost vs. performance. He also targets hostile environments where extreme temperatures, vibration and portability are required. Targa builds and supplies MBM subsystems.

### Lack of interest

Will Zachmann, vice president of research at International Data Corp., the Framingham, Mass., market research outfit, says that bubble memory has not proved to be the force it was meant to be. He, like Jones, cites improvements in conventional disk drive and CMOS technologies as part of the reason. And he feels that, although prices are coming down, applications are still too specialized. "The idea seemed right," Zachman states, "but it never delivered." He does not see bubble memory taking off in the near future.

Carol Weisenstein, formerly with Intel's MBM operations and now with its automotive department in Folsom City, Calif., says that the MBM market suffered because of the overall economic condition of the computer industry since 1984 and the fact that conventional disk drive technology has dropped in price. As to MBM's future use in personal computer and commercial environments, she says, "Most people in an office environment are willing to put up with some disk drive failures and quirks."

### Board manufacturers speak out

Bubbl-tec of Dublin, Calif., markets VMEbus-compatible bubble boards once built around Intel parts. Now, the company will switch to Hitachi devices. Chief engineer Al Foreman says Hitachi, in its 4M-bit device, offers lower prices and higher densities than does FCA. He feels it will be a long time before the cost of MBM is competitive with that of regular storage media.

Plessey Microsystems, Pearl River, N.Y., has been using Hitachi's bub-

bles in its boards for several years. Doug Patterson, marketing manager for defense and custom products feels that, because MBM technology is a generation ahead of silicon technology, it will show growth and promise.

### A look into the future

What about MBM's future? Hitachi is studying new technologies like Bloch-line that can achieve a 1G-byte capacity. Named after Nobel laureate Felix Bloch by its creator, Dr. Susumu Konishi of Japan's Kyushu University, Bloch-line devices utilize elongated bubbles and offer a 6-msec access time—10 times faster than rigid disks.

A single bubble carries more than 1 bit of data. The bits are represented by changes in polarization within the wall of the bubble domain. Bloch-line technology, which will probably not be implemented until the mid 1990's or later, could finally be the way to significantly lower the cost per bit of MBM devices to appeal to system integrators and engineers for everyday use. Zitel's Houston feels that Bloch-line technology could open a lot of commercial doors to MBM further down the road.

MemTech expects to continue the R&D started by Intel on a 16M-bit chip, while Magnesys will put more work into lowering yields via a wafer-level functional tester and circuits for its subsystem.

There is talk about developing industry-standard MBM components. Hitachi's Klink is trying to form a committee to do this. As he puts it, "What happens to all those people who were using Intel's bubbles? They have to redesign their entire board and use another company's components. This is very expensive." Klink says that Hitachi has made contact with several vendors about using the same architecture.

MBM looks like it will remain in "niche limbo" for the next decade or so. Right now the majority of system integrators do not demonstrate a need for MBM's high reliability and portability. But, whenever the price becomes right in the future, bubbles may float well above their current niche. □

### BUBBLE MEMORY VS. CONVENTIONAL STORAGE

|                   | Bubble | Conventional |
|-------------------|--------|--------------|
| Reliability       | ✓      |              |
| Power consumption | ✓      |              |
| Immunity to shock | ✓      |              |
| Error rate        | ✓      |              |
| Maintenance       | ✓      |              |
| COST              |        | ✓            |

# TEKTRONIX NEW ADVANCED PC GRAPHICS STANDS ALONE.

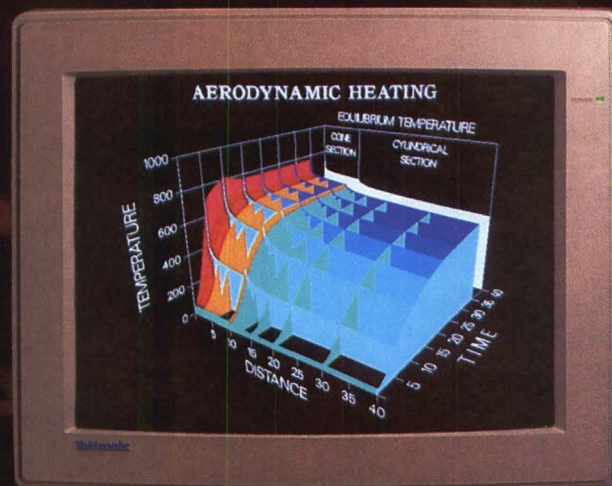

# BECAUSE IT WORKS TOGETHER.

Introducing Tek Advanced PC Graphics: a fully integrated system of high-performance graphics, easy system connectivity, and unparalleled application

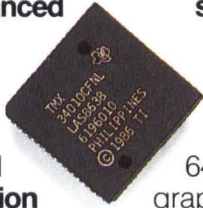

software for your PC. Tek Advanced PC Graphics starts with a flexible multiple-rate color graphics monitor that provides 640x480 Tektronix-style graphics as well as EGA and

CGA software compatibility.

Driving your monitor to a whole new level of graphics speed is Tek's PC4100 graphics coprocessor board. It features Texas Instruments® powerful TMS 34010 32-bit



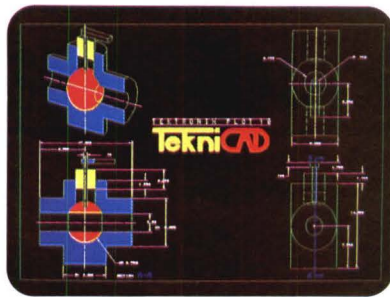
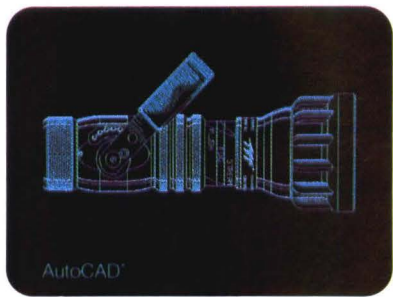

Graphics System Processor for ultra-fast throughput of your design applications. Add to that Tek's PC-05 or PC-07 terminal emulation software, and you're ready for stand-alone computing or access to a world of mainframe graphics.

To bring those applications to life, you can connect a Tek color ink-jet printer. And start producing high-resolution, vibrant hardcopy output on either paper or transparencies.

Couple all that with Tektronix worldwide support and service, and your PC can gain the

same productive advantages that host-based systems in scientific and engineering environments have had for close to two decades.

**Tek's PC4100 graphics coprocessor board delivers serious graphics on a stand-alone basis.** Built around the Texas Instruments Graphics System

Processor(GSP),™ the graphics coprocessor board achieves a combination of sophisticated graphics and fast throughput your PC just couldn't deliver before. The GSP assumes the complete graphics processing workload, freeing your PC processor for other requirements.

refresh rate. So you can use advanced packages like AutoCAD®, Zenographic's Mirage™ and VersaCAD®.

Then, to move from GSP graphics to emulation of the IBM® Enhanced Graphics Adapter(EGA) mode, you simply soft-switch. And you're

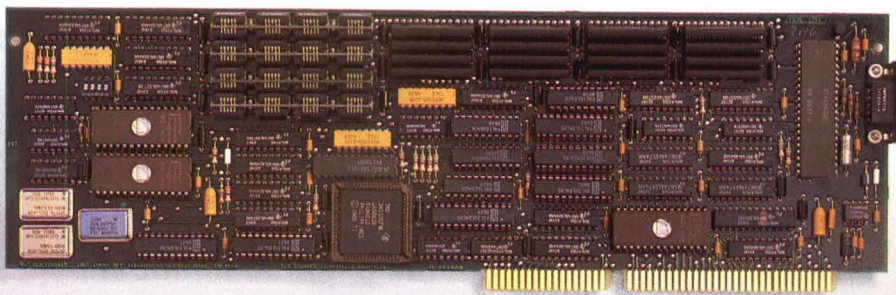

**New companion monitor brings together fine detail and maximum flexibility.** You'll view your applications on Tek's new multiple-rate monitor. In true Tek tradition, it provides ideally balanced, 640x480 addressability and a 60 Hz non-interlaced

ready to run the popular PC packages you probably already use in CGA/EGA mode—standards like Lotus® 1-2-3®, Microsoft® WORD® and Microsoft® Windows®, to name just a few.

Last, but not least, Tek's PC4100 links you to a world of mainframe graphics. All you do is load Tek PC-05/PC-07.

**Tek PC-05/PC-07 terminal emulation software gives you mainframe accessibility with the local processing power of your PC.** Because Tek PC-05 and PC-07 terminal emulation software runs under MS-DOS® 2.0 and higher, you can run your mainframe-based

Copyright © 1987, Tektronix, Inc. All rights reserved. DISSPLA and TELL-A-GRAF ANVIL-5000, SAS/GRAPH, DI-3000, ANSYS and NASTRAN are registered trademarks of ISSCO. MCS, SAS Institute Inc., Precision Visuals, Swanson Analysis Systems and MacNeal-Schwendler respectively. IBM, Texas Instruments and GSP, Lotus and Lotus 1-2-3, Microsoft, MS-DOS and Microsoft WORD and Windows, VersaCAD, AutoCAD and Mirage are registered trademarks of International Business Machines Corp., Texas Instruments, Inc., Lotus Development Corp., Microsoft Corporation, VersaCAD Corp., Autodesk, Inc. and Zenographics respectively. VPT 102 11W-7050

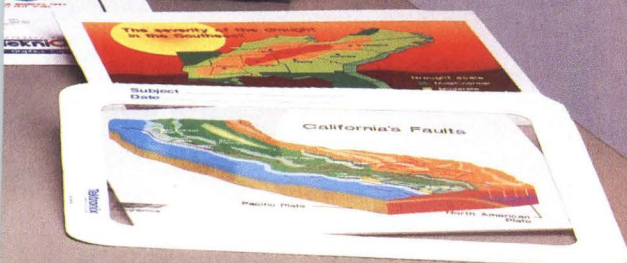

# AND SETS YOU APART.

applications software on your PC as if it were a Tek 4105 or 4107 terminal.

Which means you can quickly access the power of Tek graphics—including 4107 segments, true zoom and pan, rubberbanding, definition of up to 64 viewports and more. You can use these highly productive features with a wide range of well-known designer software packages such as ISSCO's DISSPLA<sup>®</sup> and TELL-A-GRAF,<sup>®</sup> MCS's ANVIL-5000,<sup>™</sup> SAS Institute Inc.'s SAS/GRAPH, Precision Visuals' DI-3000,<sup>®</sup> Swanson Analysis Systems' ANSYS<sup>®</sup> and McNeal-Schwendler's NASTRAN.

In addition, you can utilize software development tool sets like Tektronix PLOT 10<sup>®</sup> GKS, IGL, TCS and STI software as well as numerous driver support packages created for the 4105 and 4107.

**Completing the picture: perfect color output with Tek's reliable ink-jet printers.**

At the push of a button, the Tek 4696 lets you produce exacting color reproductions of



your on-screen display on either paper or transparencies.

Because of its 120 dots per inch addressability in both horizontal and vertical directions, you can achieve resolution of up to 1280 points x 960 points per "A" size image.

**All the key tools for software development, right from the outset.** The new Tektronix Graphics Interface<sup>™</sup> (TGI) for the PC provides the basics of Tek graphics functionality to application programs

running under MS-DOS. What's more, in-circuit emulator, C-compiler, assembler and linker are all available from Texas Instruments to help software developers write applications packages for the PC4100 graphics coprocessor board.

To enable sufficient workspace for custom interfaces or specific application programs, the PC4100 graphics coprocessor board comes standard with a full megabyte of program memory.

**Put yourself on the sure path of Tek graphics evolution.**

Whether you choose Tek PC stand-alone graphics, Tek's high-resolution monitor, Tek terminal emulation or all three, you can be assured Tek will keep you current with the best and most productive graphics. Because like all our products, Tek Advanced PC Graphics features a smooth built-in pathway to higher-level graphics.

For more information about how Tek lets you stand alone and work together, contact your local Tek representative about Tek Advanced PC Graphics. Or call, 1-800-225-5434. In Oregon, 1-235-7202.

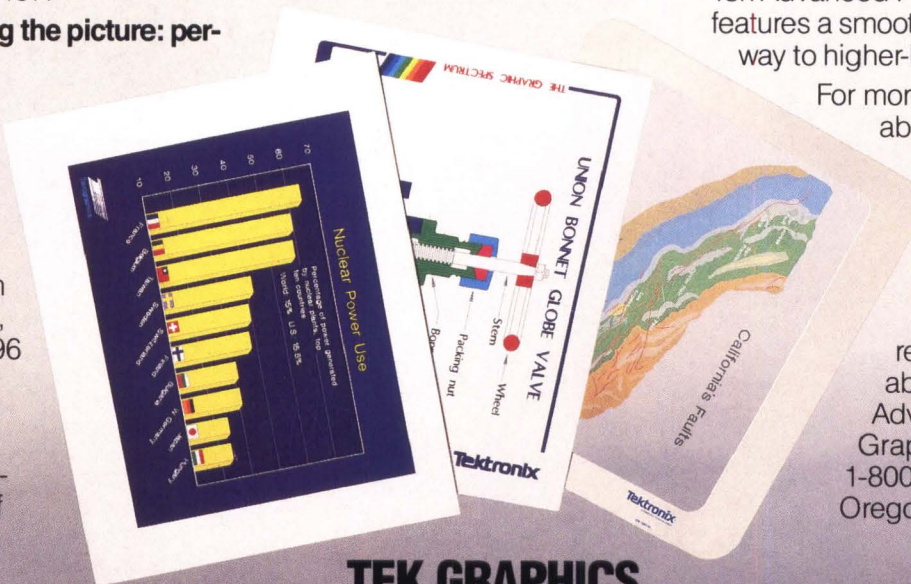

## TEK GRAPHICS PROCESSING SYSTEMS

**Tektronix<sup>®</sup>**  
COMMITTED TO EXCELLENCE

# FEATURE HIGHLIGHTS

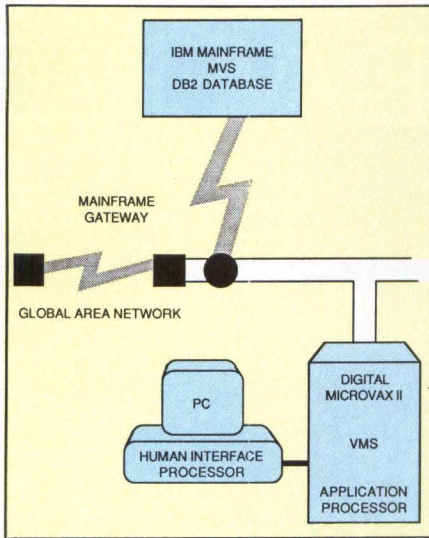

p. 65 . . . . . Integrating environments

## TRUE DISTRIBUTED DBMSes PRESAGE BIG DIVIDENDS . . .65

Distributed database management systems allow users to control locally vast amounts of geographically dispersed data. And local control means better response times, lower communications costs and increased data availability. However, as more users demand these benefits, system integrators must grapple with partitioning databases, maintaining data integrity, keeping data synchronized and solving complex communications questions. The first part of this two-part feature series investigates how some DBMS vendors are addressing the need for large amounts of on-line data in heterogeneous environments.

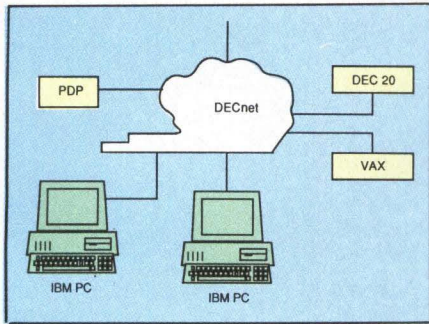

p. 91 . . . Linking PCs to mainframes

## DATABASE DEVELOPMENT TOOLS: AN EVALUATION . . .77

Can a package be operated in interpreter mode? Does it support full-screen editing of stored text? Is the code procedural or nonprocedural? Is the file-structure network or relational? An independent applications-development company supplies the essential specifications on more than 50 database development tools for software developers and system houses.

## LANs LINK PCs TO MAINFRAMES . . . . .91

Gateway hardware and software combine a LAN's resources and flexibility with access to mainframe databases. The arrival of IBM Corp. LU 6.2 products and the emergence of LAN-SNA links just happen to coincide with marketing and merger agreements between 3270 board vendors and LAN companies. These machinations signal opportunities for system integrators and OEMs in the micro-to-mainframe market.

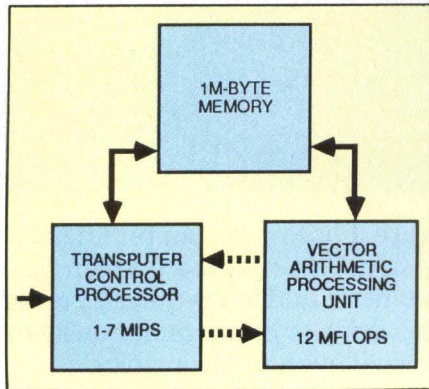

p. 105 . . . . . Battling the giants

## MULTIPROCESSORS BOOST SYSTEM POWER . . . . .105

System integrators and OEMs should be aware that suppliers use the term multiprocessor rather loosely, but true multiprocessors are optimized for multiple job throughput. *Mini-Micro Systems* profiles the offerings of the major vendors and examines their implementations of CPUs, buses and operating systems.

### DEC DIRECTIONS

## GRAPHICAL INTERFACE SPEEDS PROGRAMMING . . . 121

Cortex Corp. demonstrates new ways for programmers to produce picture-perfect linked, compiled and documented programs for DEC VAXes, including the MicroVAX.





# P9XL PINWRITER. WHAT IT DOES BUSINESS LETTER.



manufacturer of 24-pin printers. The company that consistently offers you the highest reliability ratings in the industry. (You can expect your P9XL to run for five years before it might need a repair.)

So don't waste any more time. Fly down to your nearest dealer and ask to see the new Pinwriter P9XL. Or call NEC at 1-800-343-4418 (in MA, (617) 264-8635). Or if you prefer, write to NEC Information Systems, Dept. 1610, 1414 Massachusetts Ave., Boxborough, MA 01719.



**NEC PRINTERS. THEY ONLY STOP  
WHEN YOU WANT THEM TO.**

# NEC

NEC Information Systems, Inc.

CIRCLE NO. 31 ON INQUIRY CARD

# The TeleVideo 955. Seeing is believing.

**WYSE WY-50**  
(Unretouched photo)

**TELEVIDEO 955**  
(Unretouched photo)

SALES ANALYSTS

LATEX SPECIALTY PRODUCTS INC.

PERIOD: Q3, 1985

| PERSON | ID NUMBER | TERRITORY | CUSTOMER | CUST. NUMBER | PART NUMBER | ITEM | SHIPDATE | WAREHOUSE  | SHIPDEST | CARRIER  | CUS |
|--------|-----------|-----------|----------|--------------|-------------|------|----------|------------|----------|----------|-----|
| T      | 101000000 | NEW YORK  | APEXINC  | 33333888899  | KL23487654  | 200  | 10/02/85 | NUPHILIDE  | NEW YORK | ACMETRS  |     |
| SON    | 102277754 | BOSTON    | ZINCINC  | 33388990044  | KL23450987  | 007  | 12/01/85 | CENTRALLA  | BOSTON   | ATAJAIR  |     |
|        | 100000456 | CHICAGO   | AASEHER  | 98750372378  | KL23090867  | 999  | ONHOLD   | WOODLAIN   | CHICAGO  | DUMAIR   |     |
| N      | 109857363 | ATLANTA   | TUSINC   | 77493887549  | KL23999999  | 808  | 11/19/85 | ATLANTANW  | AUGUSTA  | EWERT    |     |
| Y      | 107584948 | MINNIAP   | XYZCORP  |              |             |      | 07/85    | MINNSTPAUL | MINNIAP  | TRUCKER  |     |
| T      | 108958488 | SANFRAN   | JAKINC   |              |             |      | 28/86    | SANJOSESE  | SANMATED | SHORTAIR |     |
| TT     | 108674637 | SANJOSE   | ACDCORP  |              |             |      | 08/85    | SACRAMENTO | SANJOSE  | EZHAULER |     |
| OLD    | 107563848 | LOSANGEL  | LYNINC   |              |             |      | 18/87    | IRVINECA   | WESTLAIN | LATRUCK  |     |

| TELEVIDEO 955 VS. WYSE WY-50                           |                |            |
|--------------------------------------------------------|----------------|------------|
| FEATURES                                               | TVI 955        | WY-50      |
| Screen Color                                           | Green or Amber | Green Only |
| Optional Graphics model                                | Yes            | No         |
| Dynamically allocated non-volatile function key memory | 512            | 128        |
| Maximum non-volatile bytes per function key            | 256            | 4          |
| High contrast super dark Matsushita screen             | Yes            | No         |
| List price                                             | \$549          | \$499      |

Sure, most \$600 terminals can scrunch 132 columns onto a 14" screen. But you need a magnifying glass to read them.

Not so with the TeleVideo® 955. That's because we redesigned the proportion of our characters and put more space between them. And then put them on a high contrast, super dark screen. The result is the most readable 132 column ASCII display available.

But there's more to the 955 than meets the eye.

Take our tilt-and-swivel positioning, for example. The screen rotates through a full 270° right and left, and from -5° to +15° up and down. (Which makes backs

and necks feel a lot better.)

Then we put all this in a machine with an incredibly small footprint, measuring just 9" x 12." The result is a terminal that meets all the human factors standards recommended for adoption by the American National Standards Institute.

For more information about the TeleVideo 955, call the nearest TeleVideo

regional office listed below, and we'll give you the name of your nearest distributor.

The TeleVideo 955. It's a real eye-opener.

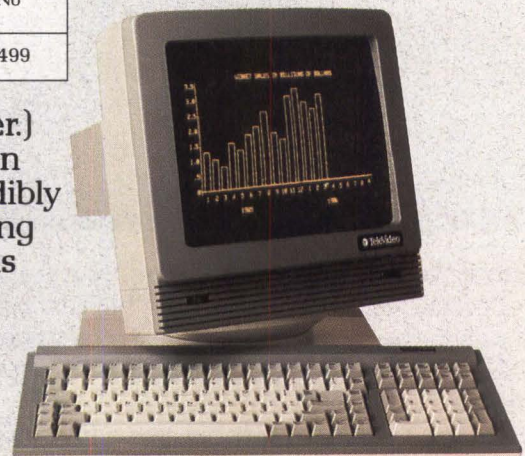

**TeleVideo®**  
Settle for more.

TeleVideo Systems, Inc., 1170 Morse Avenue, Sunnyvale, CA 94088-3568, (408) 745-7760, Regional Offices: Northwest (408) 745-7760, Southwest (714) 476-0244, South Central (214) 550-1060, Southeast (404) 447-1231, Midwest (312) 397-5400, East (516) 496-4777, Northeast (617) 890-3282. Amsterdam: 31.2503.35444, Paris: 33.1.4687.34.40, London: 44.9905.6464.

© 1987 TeleVideo Systems, Inc. WYSE is a trademark of Wyse Technology.

CIRCLE NO. 32 ON INQUIRY CARD

# TRUE DISTRIBUTED DBMSes PRESAGE BIG DIVIDENDS

Despite their slow emergence, varied types of distributed database management systems promise to help integrate heterogeneous computing environments

*This is the first of a two-part series on distributed database management systems. The second part will appear in the June issue of Mini-Micro Systems.*

**Wendy Rauch-Hindin**  
Special Features Editor

One of the next frontiers in computer processing may well be the development of distributed database management systems. Such DBMSes will meet the increasing needs of users to share vast amounts of on-line data in heterogeneous computing environments. Several vendors have responded to the demand by beginning phased introductions of distributed DBMSes; still more are about to do so.

Distributed DBMSes allow a database administrator to partition a single integrated database and its control system and distribute them across multiple geographically dispersed, autonomous nodes. They do so in such a way that the location of any particular set of data is transparent both to users and applications. In the best case, the data is also synchronized. This partitioning stands in contrast to centralized DBMSes, which allow remote database queries via terminal emulation. The distributed processing possible with such query capabilities is often confused with distributed DBMSes.

The benefits of distributed DBMSes are multifold. First, a distributed design reflects an organization's structure. Second, it allows data to be stored locally, under local control. Local storage decreases response times and communications costs and increases data availability. Third, distributing data across multiple auton-

omous sites confines the effects of a computer breakdown to its point of occurrence; the data residing on the surviving computers can still be processed.

Fourth, a database's size and its number of users need not be limited by a computer's size and processing power. Instead, distributed DBMSes accommodate an unlimited number of computers, disk drives and users. This results in the fifth advantage. In many cases, multiple, integrated small systems might be less expensive than one large system. Sixth, and perhaps most important, a distributed database need not be constrained by the physical organization of data. Consequently, a distributed database manager and a smart data dictionary can be used to integrate, access, and update heterogeneous databases but still have them appear to users as a single logical database.

## Who cares?

Banking organizations are particularly interested in distributed DBMSes, both to help manage their international trading business and to integrate activities in different parts of a bank. For example, they want to maintain domestic and foreign records and audit data in local databases and execute trades locally, but they also want to obtain worldwide status information on an ad hoc basis and execute distributed transactions.

On the other hand, for manufacturing companies with many plants and activities, distributed DBMSes' biggest attraction may be its ability to manage and access data at local sites, while also being able to integrate different types of files and data needed for computer-integrated manufacturing. The military, government agencies and large point-of-sale retail operations are still other examples of potential

---

**A distributed database's structure need not be constrained by the physical organization of data.**

---

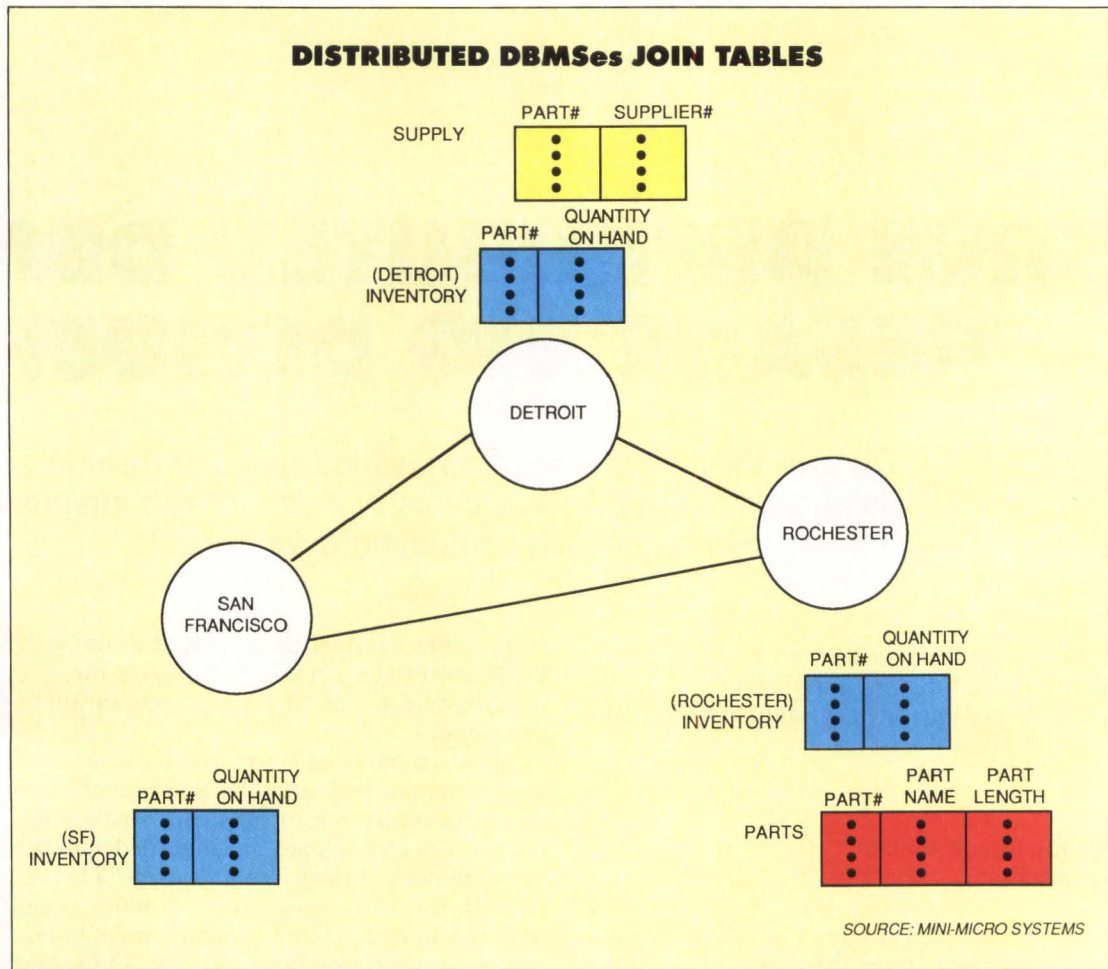

**Fig. 1.** In a distributed database, relational tables located at multiple sites can be transparently joined to answer a single query, such as, "Show me the IDs of all the suppliers who make 10-inch bolts that we have a shortage of." (Less than some specified amount is at hand.)

distributed DBMS users.

Despite this interest of some years standing, the advent of commercial distributed DBMSes has had to wait until a number of thorny technological problems were solved. Chief among the reasons for the market to develop now is the emergence of three types of computer industry standards. The first includes communications standards, such as Open Systems Interconnection, Manufacturing Automation Protocol and Technical and Office Protocols. These standards allow heterogeneous computers to exchange data. The second is the ANSI standard SQL (structured query language), which supports access to different databases. Finally, there is IBM Corp.'s LU (logical unit) 6.2 protocol, which provides a standard interface for transaction processing and allows ap-

plication programs to communicate via the application program-to-program communication (APPC) facility.

**Problems remain**

However, many technological and management problems remain to be solved before distributed DBMSes become widely used. Major concerns on the management side are how to distribute and maintain the data. Another problem with distributed DBMSes is a loss of node autonomy because, in order to support access from everywhere in the network, in many ways every node must have the same database design.

Technological problems are largely communications-related. They include excessive software and communications overhead, communication delays, poor response times, low system throughput and high communications costs.

Some database problems, such as query optimization and deadlocks, have for the most part been worked out. However, the communications and synchronization problems, combined with the programming complexity of distributed DBMSes, are too difficult to overcome

quickly. Consequently, most distributed DBMS vendors have adopted a multiphased product-introduction strategy.

As might be expected, the first introductions will incorporate the easiest to implement distributed DBMS features. Future releases will gradually add more capabilities.

**Not all distributed databases are equal**

Vendors are taking several different approaches to distributed processing and distributed databases (see Table). The oldest approach is to centralize the data but distribute the values of the data to local sites for processing.

Another existing distributed-processing scheme allows a single application to simultaneously access more than one independent database. Any file or database, however, must reside in only one node. IBM's CICS (Customer Information Control System) telecommunications monitor supports such a scheme, as do many DBMSes running on networks that support remote procedure calls.

A third approach provides periodic updated extractions from a centralized database for use at a remote site. This approach is exemplified by Digital Equipment Corp.'s VAX Data Distributor. This database allows users to employ the relational database operator of Digital's Rdb/VMS software to extract or replicate all or a subset of a central database and send it to a target node via DECnet. The database produced is a snapshot-in-time of the central database.

This extract-and-replication facility differs from most previous products in that it automatically updates the target database at a user-specified time. During the update, the extract method creates a new target-database copy, while the replication method updates only data that has changed. Target-database users can use the data for any kind of local processing, but they cannot update the central system.

Despite the name "Data Distributor," many database experts argue that this system is not a truly distributed database. However, this may not matter. For users, the big question is how many distributed database benefits the system provides.

An automobile dealership, for example, can use this type of database to locally replicate and query data associated with the cars it sells and the plants from which it buys. Users gain better response times because the data is local. In addition, this approach decreases network traffic because it decreases the number of remote queries. And the central processor is freed up for other tasks because the processing load is distributed more efficiently. On the other hand, the data might not always be up-to-date. Furthermore, Data Distributor runs only on the

VAX family.

**Slice up the database**

Partitioning data is really what distributed databases are all about. So, the most common type of distributed database being introduced is that which gives the database administrator the flexibility to partition the database and locate individual data at any location deemed suitable. Usually, it is one that is local to the region where the processing takes place.

Regardless of the location of the data, users see only a single logical database (Fig. 1). They can create a view that is a join or union of tables (relations) in different databases without being aware that the data tables span multiple locations. Knowledge of where any particular requested data is located resides in a data dictionary. The DBMS routes requests to the proper location(s) and returns the data requested.

The major reasons for partitioning the data, as opposed to just replicating it, are to reflect an organization's structure, provide locality of reference and lay the foundations for accessing and managing heterogeneous databases. These benefits must be balanced against the high costs

---

**The oldest database approach is to centralize the data but distribute the values of the data to local sites.**

---

WILL THE  
FIRST  
ONE IN,  
PLEASE  
UNPLUG™  
THE  
COMPUTER.

SYSTECH  
WE OPEN UP A LOT OF POSSIBILITIES.

**NOT ALL DATABASES ARE CREATED EQUAL**

|                                                                                                                                                                        | <i>New technical features</i>                                                                                           | <i>Reliability</i> | <i>Expandability</i> | <i>Communications overhead</i>                 | <i>Manageability</i> | <i>Data consistency, or integrity</i>                      |
|------------------------------------------------------------------------------------------------------------------------------------------------------------------------|-------------------------------------------------------------------------------------------------------------------------|--------------------|----------------------|------------------------------------------------|----------------------|------------------------------------------------------------|
| <b>Centralized DBMS:</b> System and data reside in one location on one CPU. Data values may be distributed to geographically dispersed users for local processing.     |                                                                                                                         | poor               | poor                 | very high                                      | very good            | excellent                                                  |
| <b>Distributed, non-integrated DBMS:</b> Independently operating DBMSes that can be accessed by applications on remote computers.                                      | communications                                                                                                          | good               | good                 | low                                            | very good            | low                                                        |
| <b>Distributed snapshot DBMS:</b> Copy of the central database created by extraction and replication for use at remote site.                                           | communications                                                                                                          | good               | very good            | low to medium                                  | very good            | medium                                                     |
| <b>PARTITIONED, DISTRIBUTED INTEGRATED DBMSes</b>                                                                                                                      |                                                                                                                         |                    |                      |                                                |                      |                                                            |
| <b>Distributed-query DBMS—transparent:</b> Data spans heterogeneous computers and software. Request for file may or may not require users to provide machine location. | communications, partitioning of data, distributed-query processing                                                      | very good          | very good            | low to medium if most requests are local       | difficult            | could be low                                               |
| <b>Distributed-query and -update DBMS—transparent:</b> Data spans heterogeneous computers and software.                                                                | communications, partitioning of data, distributed-query processing, distributed updates                                 | very good          | very good            | medium if most requests are local              | very difficult       | very good                                                  |
| <b>Distributed DBMS with fragmented tables—transparent:</b> Data spans heterogeneous computers and software.                                                           | communications, partitioning of data, distributed-query processing, distributed updates, fragmenting of database tables | very good          | very good            | low to medium if most requests are local       | very difficult       | very good                                                  |
| <b>Replicated, distributed DBMS:</b> Data is replicated and synchronized at multiple sites.                                                                            | communications, synchronization of redundant data                                                                       | excellent          | very good            | medium because of synchronization requirements | medium               | medium to very good depending on synchronization technique |

and overhead that can occur if applications require large numbers of data accesses to multiple remote sites. The costs and overhead problems are compounded if distributed update

capabilities to keep the data synchronized are involved. For these reasons, most initial introductions of distributed DBMSes support distributed queries, but full distributed-update

facilities are usually planned for later releases.

Tandem Computers Inc. was the first to support distributed queries, distributed updates and synchronized replicated data, with its Encompass database. An outgrowth of Tandem's quest for a fault-tolerant system (where one CPU could transparently process the data and transactions of a failed CPU), Encompass is the only commercial, fully distributed DBMS that has been in the field for several years.

But Tandem no longer stands alone. Relational Technology Inc. (RTI) now offers Ingres/Star, a distributed version of the Ingres database; Oracle Corp. has Oracle SQL\*Star, a distributed version of its Oracle database. Both systems can retrieve data and perform joins across multiple sites and update any site in the network, all transparently to the user. However, the current versions of these DBMSes restrict updates to only a single site at a time. The ability to perform the, more difficult, distributed updates within a single transaction must await the next releases.

Applied Data Research Inc.'s new version of DNET, Release 2.0, supports location-independent distributed updates within one transaction. And Computer Corp. of America (CCA) has developed a fully distributed DBMS, with data synchronization capabilities, under contract for the military. CCA is now working on a commercial, general-purpose distributed DBMS called Adaplex. It plans to add distributed capabilities to its model 204 DBMS.

By the end of the year, Unify Corp. also will have a distributed version of its Unify database that will transparently perform distributed updates within a single transaction. And, to round out the list, later this year Informix Software Inc.'s Informix DBMS will support transparent distributed query capabilities that will perform joins on tables located on different machines.

**Fragmentation is the next step**

Database vendors are working on distributed DBMSes that allow users to fragment individual database tables and distribute the fragments across different nodes. In a horizontal-fragmentation scheme, different rows, or records, of a particular table might be distributed to different sites. In a vertical-fragmentation scheme, the columns, or field attributes, would reside in different places. In either case, the application program and the DBMS handle the table fragments at the various locations as if they were a single relation. RTI plans this fragmentation capability for the third quarter of 1988; the other database companies have not yet released their dates.

The advantages of fragmenting tables are flexibility and less need for intelligence in applications. Here's why.

As mentioned, reflecting an organization's structure is a major reason for partitioning data. This can be accomplished by storing in separate tables data that is local to a region or operation. Applications that need data from tables at several sites create a join or union of the tables. But, to create that join or union, it is necessary for the application to contain knowledge of how the data is distributed in different tables and how the tables are related. The resulting query can be complex (Fig. 2). If the data is contained in a single table that has been partitioned and distributed, the DBMS manages the complexity.

The need for automatic management of this complexity is most important when changes are made in an organization. For example, a company with regional offices in Chicago and Detroit might have a "Chicago Employees" relation and a "Detroit Employees" relation. If, as part of a cost-cutting move, the company combines these offices, it would be illogical for it to maintain two separate tables. Unfortunately, combining them into a single "Employee table" for the new regional office requires changing every application that references the Chicago or Detroit employee tables. However,

---

**Partitioning data is really what distributed databases are all about.**

---

BEFORE  
YOU TURN  
YOUR  
COMPUTER  
ON,  
UNPLUG™  
IT.

SYSTECH  
WE OPEN UP A LOT OF POSSIBILITIES.

CIRCLE NO. 34 ON INQUIRY CARD

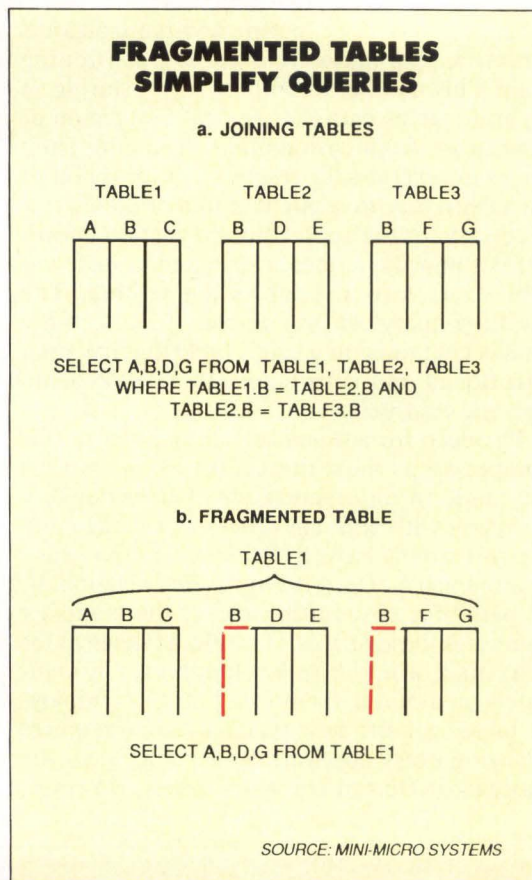

**Fig. 2. A query that requires joining three tables (a) containing ABC, BDE and BFG on field B (the common field) is more complex than a query referring to a single table containing fields A, B, C, D, E, F and G, where the table is fragmented across three sites (b). As the dashed line in this Ingres/Star query indicates, Ingres/Star keeps track of the common field.**

if "Employees" were a single table, fragmented horizontally, the only change necessary would be to inform the data dictionary that the Detroit and Chicago employee data are located in their new site. Similarly, use of a vertically fragmented table would eliminate the need to modify applications if a company changes a manufacturing process and brings in a new machine that combines two processes into one.

**Unity in diversity**

Even though Tandem and the database vendors who developed the initial distributed DBMSes did so to bring data closer to users, it is the need to link heterogeneous computing environments that will drive the market in the future.

Drawing attention to this concept is IBM's decision to stop work on its prototype distributed database R\* (pronounced "R Star"),

which supported distribution of data across large mainframes. After having experimented with R\* since 1979, IBM found, when it demonstrated the prototype, "that what the customers really wanted was the ability to share and move data within an enterprise, across desktop computers, workstations and intermediate-sized systems that would be connected via local networks or other communications methods," says Robert Yost, one of two managers for IBM's Starburst project. IBM's reaction was to begin development of a new distributed database, called Starburst, which Yost makes clear is still an experimental system.

**Big Blue's blueprint**

Nevertheless, Starburst is taking into account what appears to be all of the customers' data-sharing requirements. In particular, IBM is focusing on portability and extensibility. As to portability, the initial Starburst is being implemented on the IBM RT PC RISC (reduced instruction set computer) workstation under AIX—IBM's version of System V UNIX—as well as on an Intel Corp. 80286-based PC/AT running PC-DOS. These systems are vehicles for understanding what is necessary to make Starburst portable across a variety of computers, operating systems, networks, databases and so forth.

Long-term work on extensibility was undertaken because the range of applications for workstations and intermediate-sized systems is much greater than the range for mainframes. Extensibility means that the database can be expanded to support new types of data, including text, images, voice, complex objects and abstract data types—as well as support new operations on these data—in order to adapt to changing environments.

The extensibility characteristic actually applies to any database. It is particularly important to distributed DBMS users, because they are likely to want to integrate application data such as CAD/CAM, inventory control, images and statistical databases. And, for performance reasons, these users will want their specialized functions to run at the level of the database, as opposed to the level of the application.

However, specialized data and functions on different machines may introduce several variants of Starburst within the one, albeit distributed, database, as well as heterogeneity in terms of the ability of databases on different machines to work together.

This could lead to a problem that IBM's SNA (Systems Network Architecture) has been accused of. That is, becoming so enormous and multifunctional that, when slimmed down for practical implementation, two of them might not be able to talk to each other. To prevent



such a happening, Starburst designers are trying, from the start, to define a core that should be common to every version of the database. This core will not only permit sharing but also will support the requirements of specific application areas with optimized performance.

Another Starburst objective is a uniform high-level language to access local and distributed data, both within an enterprise and across enterprises. In Yost's view, this high-level language may well be SQL and extensions to SQL, both in terms of the data types and the operations it supports.

It probably will be SQL, in fact. Starburst-gazers agree that Starburst could provide the blueprint for most vendors' future distributed databases, especially in terms of portability and heterogeneity.

UNIX databases are examples—support heterogeneity because they are relational, use SQL, run on a variety of computers from PCs through workstations and minicomputers and frequently work under multiple operating systems. Oracle's SQL\*Star, for example, supports transparent queries and updates across the Oracle database and IBM's DB2 and SQL/DS products. And support for the non-SQL-based VSAM and IBM's IMS (Information Management System) are forthcoming later this year. RTI's Ingres/Star is also compatible with DB2 and has a prototype gateway to IMS that uses the SQL interface to IBM's Data Extract (DXT) product. Informix, too, is working on connecting to DB2.

As for mainframe/minicomputer databases, Information Builders Inc. is moving in the direction of a distributed DBMS that supports multiple heterogeneous databases. It is well-positioned to do so because, on a single node, its Focus database can already read, relationally join, and generate reports from any Focus, IBM, or DEC files and can also generate SQL calls to relational databases. And the company has begun extending this capability. As a start, it supports distributed queries and distributed updates, within a single transaction stream and across dispersed Focus databases on DECnet. A smart data dictionary to provide transparency is due next year.

Information Builder's rationale is simple. "Access capability within only one proprietary database or network is a limiting concept in that no large company has all of its data in a single file type," says Verne Sheidler, marketing support manager at Information Builders.

Cincom Systems and Cullinet Software Inc. are in complete agreement with this kind of thinking. According to Cincom, most of its clients have heterogeneous databases, and they are trying to find some way to integrate them. To provide solution, Cincom will extend its

existing support for vertically fragmented, replicated data across IBM (IMS, DB2, and VSAM), DEC (RMS), and Cincom (Supra and Ultra) databases and files to still other databases, primarily those that speak SQL. And beginning with distributed query capabilities, it will gradually extend this support across multiple nodes.

For its part, Cullinet claims its customers are overburdened with existing centralized production databases. They want to distribute part of their database processing, application and software development down to departmental minicomputers and PCs.

Cullinet's response was to develop a three-tiered strategy that encompasses distributing not only databases but also applications across PCs, minicomputers and mainframes. The company plans three main products, all SQL-compatible. One is ADS Plus/PC, a PC version of Cullinet's ADS on-line application-development system. The second is IDMS/Distributed, a relational database that will run on VAX computers and PCs. The third is the mainframe-based Release 11 of IDMS/R.

Such multitiered distributed architectures may well be the most promising, near-term way

---

**Most initial introductions of distributed DBMSes support distributed queries, but full distributed-update facilities are usually planned for later releases.**

---

YOU'LL  
UNPLUG™  
YOUR  
COMPUTER  
SOON.

SYSTECH

WE OPEN UP A LOT OF POSSIBILITIES.

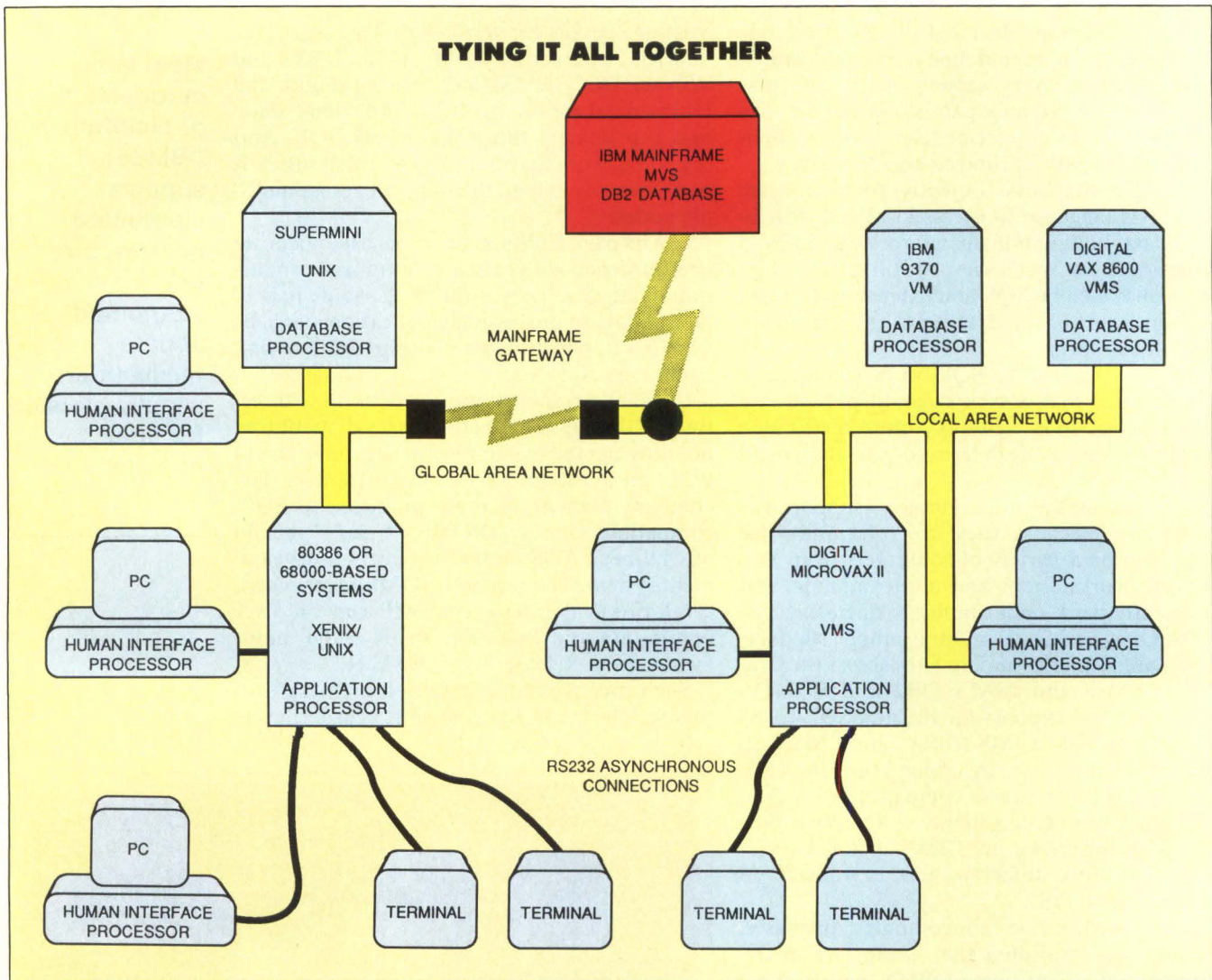

**Fig. 3. A multitiered Cooperative Processing Architecture, from Unify, allows databases and applications to be distributed across interconnected computers, ranging from mainframes and minicomputers to workstations and PCs.**

to cope with data sharing across today's heterogeneous computer systems. Accordingly, another proponent, Unify Corp., has developed what it calls a "Cooperative Processing Architecture" to help application developers grapple with this emerging environment (Fig. 3).

The computer hardware in this architecture is arranged in three tiers: PCs, UNIX- and VMS-based workstations and minicomputers (VM to come) and mainframes. The end-user interface and the data-entry and query tools run on PCs. The PCs provide fast response and interactivity. They also offload UNIX and VMS machines.

The UNIX and VMS machines handle the

flow of control and application logic. They provide the large memories and high performance needed by applications. Also, with this cooperative architecture, applications can be distributed across the UNIX or VMS machine and the PC.

The database is handled either by the UNIX or VMS machine or by a mainframe at the third layer. Still other machines can be networked at the second and third layers to distribute the data in the database. Access to the different databases occurs via an SQL interface.

Most vendors today agree with the multilayer distributed processing concept. However, Robert McCord, product marketing manager for distributed technologies at RTI, and Kenneth Cohen, director of product marketing at Oracle, both point out that SQL is not an automatic panacea to database compatibility. Even if high-level SQL statements are identical, subtle differences at the internal level make it necessary to map a database's SQL statements into the call to which each individual implementa-

## Companies mentioned in this article

**Applied Data  
Research Inc.**

Route 206 and Orchard Road  
Princeton, N.J. 08543  
(201) 874-9000  
Circle 301

**Cincom Systems**

2300 Montana Ave.  
Cincinnati, Ohio 45211  
(513) 662-2300  
Circle 302

**Computer Corp.  
of America**

4 Cambridge Center  
Cambridge, Mass. 02143  
(617) 492-8860  
Circle 303

**Cullinet Software Inc.**

400 Blue Hill Drive  
Westwood, Mass. 02090  
(617) 329-7700  
Circle 304

**Digital Equipment Corp.**

146 Main St.  
Maynard, Mass. 01754  
(617) 897-5111  
Circle 305

**IBM Corp.**

1133 Westchester Ave.  
White Plains, N.Y. 10604  
(914) 765-1900  
Circle 306

**Information Builders Inc.**

1250 Broadway  
New York, N.Y. 10001  
(212) 736-4433  
Circle 307

**Informix Software Inc.**

4100 Bohannon Drive  
Menlo Park, Calif. 94025  
(415) 322-4100  
Circle 308

**Oracle Corp.**

20 Davis Drive  
Belmont, Calif. 94002  
(415) 598-8000  
Circle 309

**Relational Technology Inc.**

1080 Marina Village Parkway  
Alameda, Calif. 94501  
(415) 769-1400  
Circle 310

**Tandem Computers Inc.**

19333 Vallco Parkway  
Cupertino, Calif. 95014  
(408) 725-6000  
Circle 311

**Unify Corp.**

4000 Kruse Way Place  
Lake Oswego, Ore. 97034  
(503) 635-6265  
Circle 312

tion responds. Data types must be converted. Also, relations and attributes must appear the same.

Another problem is that most vendors' SQLs are not exactly the same. Adoption of the International Standards Organization standard SQL would promote compatibility but create another problem. Specifically, the SQL currently under consideration by ISO is only a subset of DB2 SQL, and that could create acceptance problems.

A more serious problem occurs, according to Tony Percy, director of product planning at Applied Data Research, if the meaning and identity of the data between different systems are different because the databases were designed without some central data administration. Pieces of data may have the same name but mean different things, or vice versa. Or users of one database may use a zero, meaning no value in a field; users of another may use a specified "null" symbol. In either case, users will receive wrong answers to their queries. And they may not be able to recognize that the answers are wrong.

What all this means is that, to obtain the benefits of distributed DBMS technology requires two things: applications appropriate for distribution and coordination of the distributed databases. Coordination means a change in an individual's style of doing business, and such changes do not happen overnight. Consequently, software developers and system integrators can expect distributed DBMSes to follow the pace of all new commercial technologies: they will evolve slowly. □

Interest Quotient (Circle One)  
High 483 Medium 484 Low 485

### KEEP YOUR SUBSCRIPTION

To keep your free subscription to Mini-Micro Systems, turn back to the requalification card attached to the front cover. Please fill it out and return it to us right away.

DON'T BE  
THE  
LAST ONE  
TO  
UNPLUG™  
YOUR  
COMPUTER.

SYSTECH

WE OPEN UP A LOT OF POSSIBILITIES.

# Follow this line.

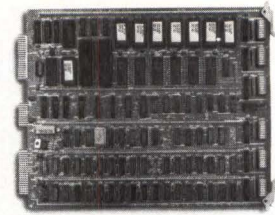

## QMS Magnum® Series Board

Controller board for adding industrial graphics to virtually all impact printers.

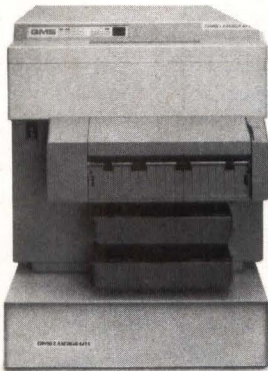

## QMS Lasergrafix™ 800 II—New

8 pages per minute.  
Engineering, scientific, CAD.  
Multi-user environments.

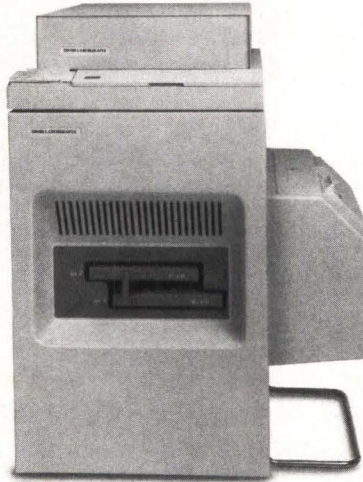

## QMS Lasergrafix 2400

24 pages per minute.  
Engineering, scientific, CAD.  
Multi-user environments.



## QMS Lasergrafix 800

8 pages per minute.  
Engineering, scientific, CAD.

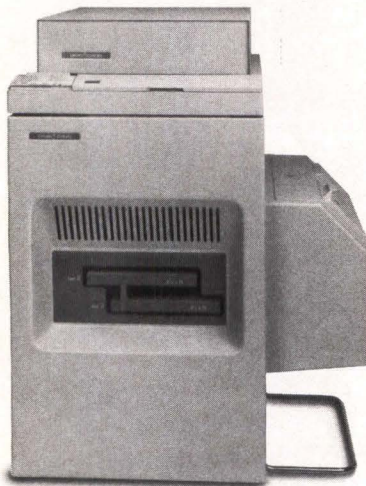

## QMS-PS 2400

24 pages per minute. 11" x 17" output.  
PostScript language. Electronic publishing.

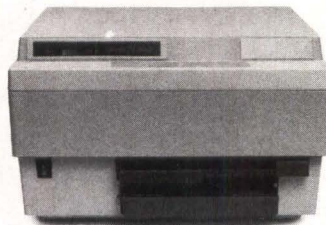

## QMS-PS® 800

8 pages per minute. PostScript® language.  
Desktop publishing.

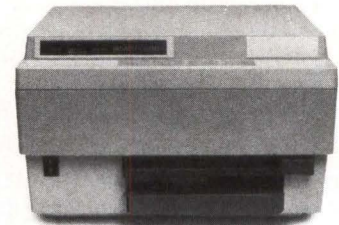

## QMS-PS 800+ —New

8 pages per minute. PostScript language.  
Enhanced desktop publishing.

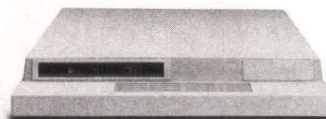

## PS Jet™

PostScript upgrade for laser printers  
using Canon® engines. 13 resident  
typefaces.

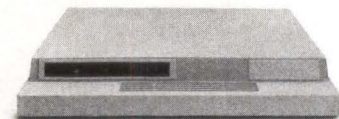

## PS Jet + —New

PostScript upgrade for laser printers  
using Canon engines. 35 resident  
typefaces.

The QMS family of products can provide VAR's and OEM's with a printing solution for just about any application. Like industrial graphics. Word processing and office automation. Desktop/in-house printing and publishing. Advanced scientific/engineering/CAD graphics. You'll find

QMS printer technology falls in line with all your customers' needs.

The flexibility and compatibility of QMS products make your job of pulling together a total system solution for your clients a lot easier. VAR's and OEM's can choose from almost every product

we manufacture. Our product families represent innovative combinations of print engines, controllers, fonts and accessories to help you fit almost any niche. Plus, we're always willing to make custom modifications to our products to help you close the sale.



**QMS WedgeBox®**  
*External printer interface.*



**QMS KISS™**  
*6 pages per minute.  
Word processing/office automation.*



**QMS Big KISS II™—New**  
*8 pages per minute.  
Word processing/office automation.  
Multi-user environments.*



**QMS Lasergrafix 1500**  
*15 pages per minute. Engineering, scientific, CAD.  
Multi-user environments.*

# It will take you

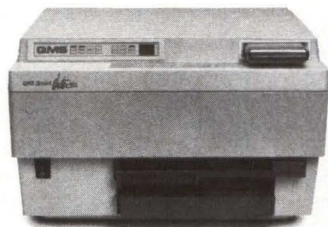

**QMS SmartWriter® 80+**  
*8 pages per minute.  
Word processing/office automation.  
More memory for faster page processing.*



**QMS SmartWriter 8/3X—New**  
*8 pages per minute.  
Word processing/office automation.  
IBM® System 3/X environments.*



**QMS SmartWriter 150**  
*15 pages per minute.  
Word processing/office automation.  
Multi-user environments.*

# anywhere you want to go.

Of course, you can expect a pricing structure that keeps your margins healthy and your bids competitive. What's more, you have the comfort of working with a \$75 million company well-acquainted with the needs of the VAR/OEM market. A company that will

react quickly to help you seize an opportunity. A company that's placed more printers and printer technology, in more different printing environments, than anyone else.

Find out how our line can have a positive effect on your bottom line.

Call toll-free **1-800-631-2692** for further information on our VAR/OEM programs.

PostScript® is a trademark of Adobe Systems, Inc. IBM® is a trademark of International Business Machines Corporation. Canon® is a trademark of Canon U.S.A., Inc.



# The right IBM channel connections will get you on the bus faster.

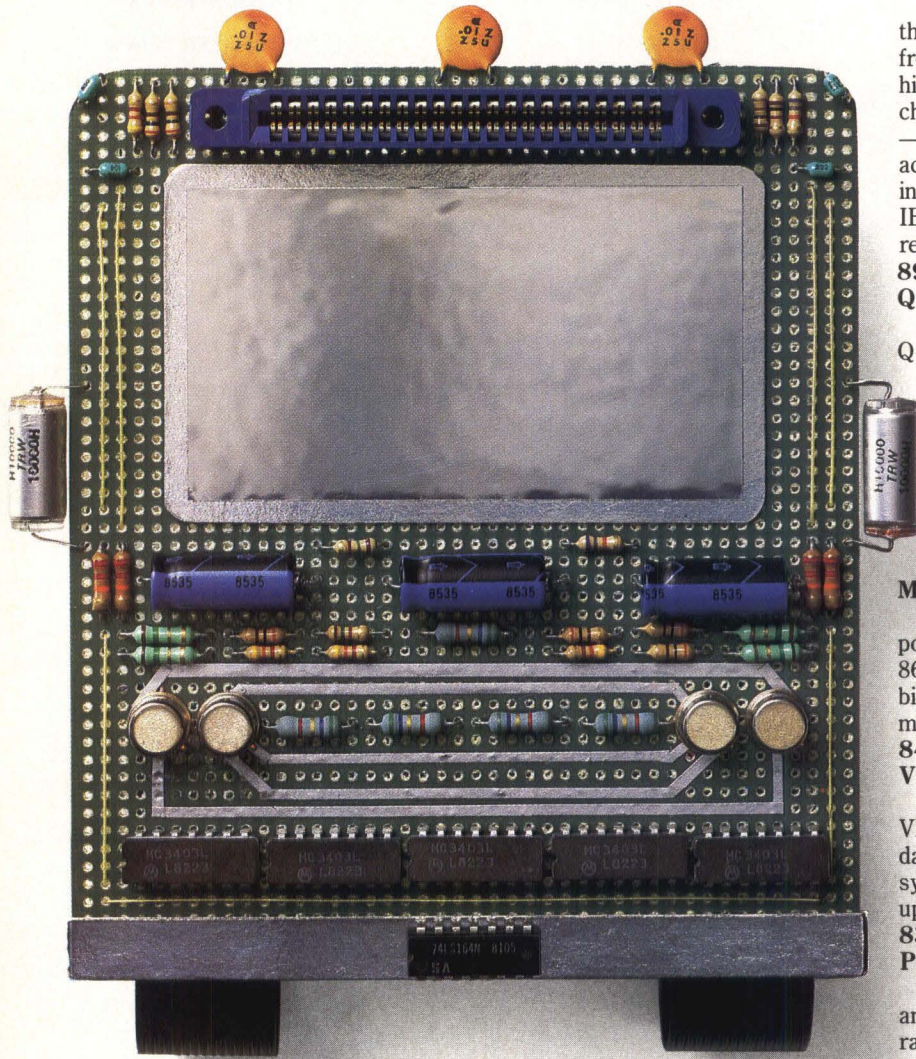

Why settle for slow serial connections when the right connections will transport your data from the IBM channel to your bus? We offer high-speed interfaces to IBM® and compatible channels in a broad range of bus configurations — so all your devices can have the same fast access to the mainframe. And since we've been interfacing non-IBM devices and networks to IBM channels for over 12 years, we offer reliability no one else can match.

#### **8900A Channel Interface — Q-bus configuration**

Our 8900A Channel Interface is based on a Q-bus™ design. Under the control of your device's DEC CPU, the 8900A is a fully functional control unit. It responds to any or all of the 256 IBM subchannel addresses with data transfer rates on the channel of up to 1.2 megabytes per second. The 8900A will run multiple control unit emulations simultaneously, and serve multiple downline devices.

#### **8600 Channel Interface — Multibus configuration**

Our 8600 Channel Interface is based on Intel's popular Multibus® architecture. The 2-board 8600 matches our 8900A interface in both flexibility and power — but transfers data at up to 2 megabytes per second on the channel.

#### **8400 Channel Interface — VME bus configuration**

The 8400 Channel Interface incorporates the VME bus design on a single board. It transfers data between the IBM channel and the VME system memory by Direct Memory Access at up to 1 megabyte per second.

#### **8300 Channel Interface — Programmable parallel interface**

The 8300 Channel Interface is not based on any external bus architecture. It moves data at rates of up to 500K bytes per second and talks to a downline device through an 8- or 16-bit programmable parallel interface. If you're an OEM, the 8300 can be put on your form factor or bus for incorporation directly into your device.

We'll not only get you from an IBM channel to the right bus. We'll get you there quickly and reliably. Call us at 1-800/531-5167 (in Texas, 512/288-1453) or write KMW Systems Corporation, 8307 Highway 71 West, Austin, Texas 78735.



**KMW  
SYSTEMS  
CORPORATION**

*For the right connections*

Auscom is now a division of KMW Corp.

IBM is a registered trademark of International Business Machines Corp.  
Multibus is a trademark of Intel Corporation.  
Q-bus is a trademark of Digital Equipment Corporation.

**CIRCLE NO. 38 ON INQUIRY CARD**

BEFORE YOU BUY A NEW VEHICLE,  
LOOK AT THE AWARD WINNERS!

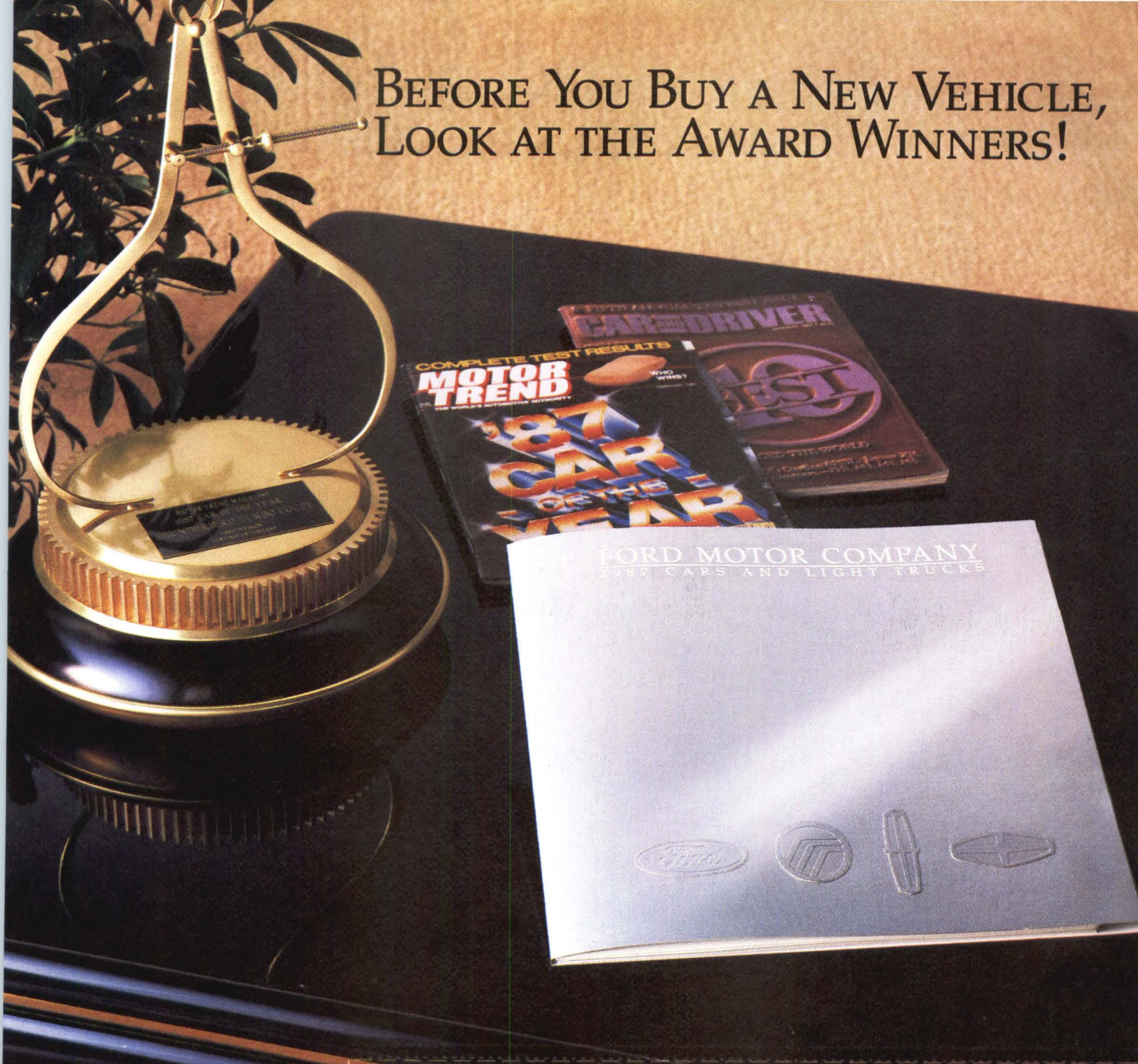

**FREE  
FOR THE ASKING**

A superb book with all the 1987 Ford, Mercury, Merkur and Lincoln vehicles including:

- Thunderbird Turbo Coupe—*Motor Trend's* "Car Of The Year"
- Taurus and Mustang GT—Two of *Car and Driver's* "Ten Best"

Send for your free copy today.

To receive your complimentary copy of the Ford Motor Company Collection of 1987 Cars and Light Trucks, use this postage-paid card.

NAME (PLEASE PRINT) \_\_\_\_\_

ADDRESS \_\_\_\_\_

CITY \_\_\_\_\_

STATE \_\_\_\_\_

ZIP \_\_\_\_\_

Please tell us when you plan to purchase your next new vehicle:

0-3 mo.    4-6 mo.    7-12 mo.

1-2 yrs.    No plans within next 2 yrs.

SERCMM C

# THE FACTS



## THUNDERBIRD

Model: Ford Thunderbird, LX, Sport, Turbo Coupe  
 Body Style: 3-door sedan  
 Powertrain: V6, 2.8L  
 Engine Size: 3.0 liter V6 - 8-cyl., 3.0 liter V6 - 8-cyl., 2.3 liter V6 Turbo - 4-cyl.  
 Fuel Economy: EPA estimated city mileage varies between 18 to 23 mpg for Thunderbird engine/gearbox combinations.  
 Drivetrain: Rear wheel drive  
 Transmission: 5-speed manual overdrive, 4-speed automatic overdrive  
 Manufacturer's Suggested Retail Price for Thunderbird models not including taxes, title, license, custom charges or optional equipment: \$11,000 - \$18,000. Thunderbird Turbo Coupe equipped shown: \$18,000.



## SABLE

Model: Mercury Sable DL, LS  
 Body Style: Four-door sedan  
 Powertrain: Six-cyl.  
 Engine Size: 3.0 liter V6 - 6-cyl.  
 Fuel Economy: EPA estimated city mileage is 18 mpg for Sable engine/gearbox combinations.  
 Drivetrain: Front wheel drive  
 Transmission: 4-speed automatic overdrive  
 Price: Manufacturer's Suggested Retail Price for Sable models not including taxes, title, destination charges or optional equipment: \$11,300 - \$14,444. Sable CD equipped as shown: \$12,800.

### THE CARS... THE TRUCKS... THE PRICES...

Over 100 colorful 7"x10" photographs bring you the style and design of Ford Motor Company cars and light trucks. Settle back and review all Ford, Mercury, Merkur and Lincoln vehicles in this unique collection.

We've even included vital information about each vehicle—body style, seating capacity, engine size, EPA rating and, of course, the price.

This handsome, informative book will be delivered to your home at no cost. So, complete the postage-paid card and mail it today.



### BUSINESS REPLY MAIL

FIRST CLASS PERMIT NO. 284 LINCOLN PARK, MI

POSTAGE WILL BE PAID BY ADDRESSEE

The Ford Motor Company Collection  
 1987 Cars and Light Trucks  
 P.O. Box 7039  
 Lincoln Park, MI 48146-9990

NO POSTAGE  
NECESSARY  
IF MAILED  
IN THE  
UNITED STATES



If the reply card has been removed, you may write directly to:

**The Ford Motor Company  
 Collection**  
 1987 Cars and Light Trucks  
 P.O. Box 7039  
 Lincoln Park, MI 48146

and request your free book.



Quality is Job 1.



# DATABASE DEVELOPMENT TOOLS: AN EVALUATION

An independent company evaluates over 50 database development tools available for applications developers, software houses and end users

The database market limelight shines primarily on the larger suppliers, such as Ashton-Tate, Informix Software Inc., Oracle Corp., Relational Technology Inc. and Unify Corp. However, to facilitate the work of software developers and system houses, a multitude of smaller suppliers also provide database development tools. Prices for these tools (which range from \$35 to over \$1,500) vary as widely as the capabilities offered.

To assist database developers, Humanic Systems Co., Lexington, Mass., earlier this year released an evaluation of available development tools. Humanic Systems is an independent applications-development company. Its latest package is the MKS expert system, which the company wrote with a text-oriented database management system. MKS (Management Knowledge System) combines a knowledge base with fourth-generation database languages. Humanic Systems regularly evaluates database development tools for its own use in applications development.

The accompanying "Column Heading Explanations" will assist you in reading the evaluation table. The chart also includes an explanation of the abbreviations used in the table, as well as definitions of some of the terms.

The evaluation table covers over 50 database development packages. Where there are several package entries in a single row, the information in the related column—including prices—applies to a combination of those packages.

The packages are arranged in the following order. The first four entries are packages that support SQL (IBM Corp.'s Structured Query Language) but do not have run-time fees. The next group of packages—through Advanced Development Technologies' The Creator, does not support SQL and does not require run-time

fees. Humanic Systems' president, W. Curtiss Priest, explains the importance of run-time fees thus: "For example, if you develop a package and you're facing, say in the case of [Relational Technology's] Ingres database, paying \$300 for a run-time license, you can't even think of marketing the package for \$200. Ingres and [Oracle's] Oracle database wrap everything in a single package, at a relatively high price."

The next group of packages, from Database Systems Corp.'s QINT to Microrim's R:base 5000, has run-time fees and supports SQL. The next group, from Ashton-Tate's dBASE III Plus to Software Products International's Open Access II, has run-time fees but does not support SQL.

The last group employs languages designed for library search problems. With these packages you do not need SQL, except for internal database control. This group includes text-based management systems (TBMS in the Table) such as Dayflo Inc.'s Dayflo as well as end-user-oriented packages with proximity-searching capabilities, such as ZyLab Corp.'s ZyIndex. An example of a proximity-searching database query is "Did the word 'white' occur next to the word 'dog'?"

Humanic Systems includes this disclaimer with its evaluation: "The evaluation provided was conscientiously performed but may have errors or omissions because of the breadth of the undertaking. No user of the information should make momentous decisions or claims without obtaining and testing the various products described."

A list of database development tool suppliers represented in the table follows the evaluation. The list includes full company addresses and phone numbers.

—David Simpson, Senior Editor

Until now, you expected to get what you paid for. Bruning's new ZETADRAF 900 E-size, single sheet plotter gives you *more*.

How? We've designed and engineered a totally new E-size plotter to the point where it outperforms every other plotter of its type.

And at the same time, we reduced the price!

The drawing quality is superb. And, when you consider 6 g's acceleration, 45 ips chart speed and 8-pen color capability, it's unmatched.

Of course our faster plot speed means your output is higher than ever. ZETADRAF 900 could cut the plot time for your most dense design in half.

ZETADRAF 900 supports all major CAD software packages and

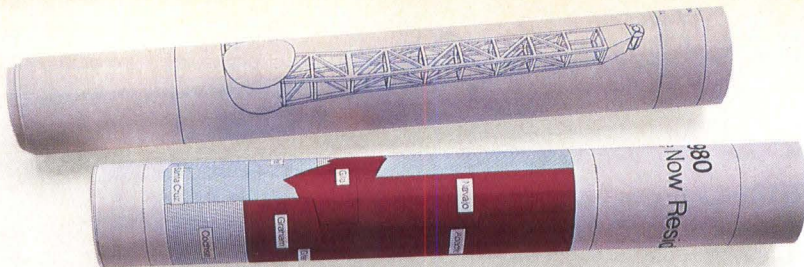

is compatible with most computers. Interfaces include RS232, IEEE-488, GML and HPGL.

No prior plotter experience is required, even for liquid ink. ZETADRAF 900 has two levels of operation—novice and advanced. But *everyone* appreciates features such as the angled, LCD control panel and the ability of the plotter to store even complex user-designed configurations.

Sorry CalComp and HP. We just didn't realize when we started out that we could produce so much plotter for so little money. But we did. Get all the facts about ZETADRAF 900 or our other ZETA drafting plotters by calling (415) 372-PLOT or write:

Bruning Computer Graphics  
777 Arnold Drive  
Martinez, CA 94533  
TWX 910-481-5951



CIRCLE NO. 39 ON INQUIRY CARD

**BRUNING**

Introducing the  
ZETADRAF 900  
for \$7,950.

**We just raised the  
performance level  
for single sheet,  
E-size plotters.**



**We also lowered  
the price!**

## Column heading explanations

**Price**—Current list price (VAR pricing is often 40 percent less.)

**(RT fee)**—Does vendor support run-time applications and if so, what is the royalty fee? If not, what is the cost per application? (There is usually quantity discounting for run-time licenses of up to 50 percent to 70 percent for high volume.)

**SQL**—Does the package provide SQL (IBM's Structured Query Language) or a similar language?

**Text store**—Can the package store more than 256 characters per field and, if so, how many? And are they stored within the database structure or as a separate text file? "No" almost always means that there is a 256-character limit, rarely less.

**Text editor**—Does the package support full-screen editing capability for stored text?

**Interpreter**—Can the package be operated in interpreter mode to see results of single-line commands?

**Compiled/called**—Can the code be compiled, and can it be called (or can it call the database management system file handler)?

**C-fh**—Can a C program access the file handler (and other fourth-generation language commands)?

**C-sub**—Can the package call C subroutines?

**X**—Can the package code be compiled to increase execution speed?

(Other supported languages such as Pascal and FORTRAN are included if known.)

**Nonprocedural or procedural**—Is the code nonprocedural or procedural and, if a mixture, what sort of mixture?

**General attractiveness**—General attractiveness reflects the range of capabilities and ease of implementation (highly subjective). Note: A low score may simply mean that the package only performs file management, and that, although it may be excellent at that task, it lacks other tools useful for applications developers.

**Notes**—Includes package comparisons, results of speed tests, or type of file structure such as network or relational.

## Definitions and abbreviations

**Y**—Yes

**N**—No

**Y-N**—Parts are; and parts are not

**NA**—not available

**4GL**—fourth-generation language: high level of nonprocedural capability

**Derby**—Derby Information Systems: A company that conducts annual contests in which database

companies are invited to compete on a single database-related problem. In other words, the company performs database development tool benchmarks, comparing code, determining how procedural or nonprocedural the code is, etc. The company is located in Berkeley, Calif., (415) 841-1234.

**QBE**—Query-By-Example: IBM's fill-in-the-form mainframe query language

**B-tree**—Internal structure of databases used by most relational database vendors

# 2,000,000 DOTS PER SCREEN. THAT'S WHAT IT TAKES.

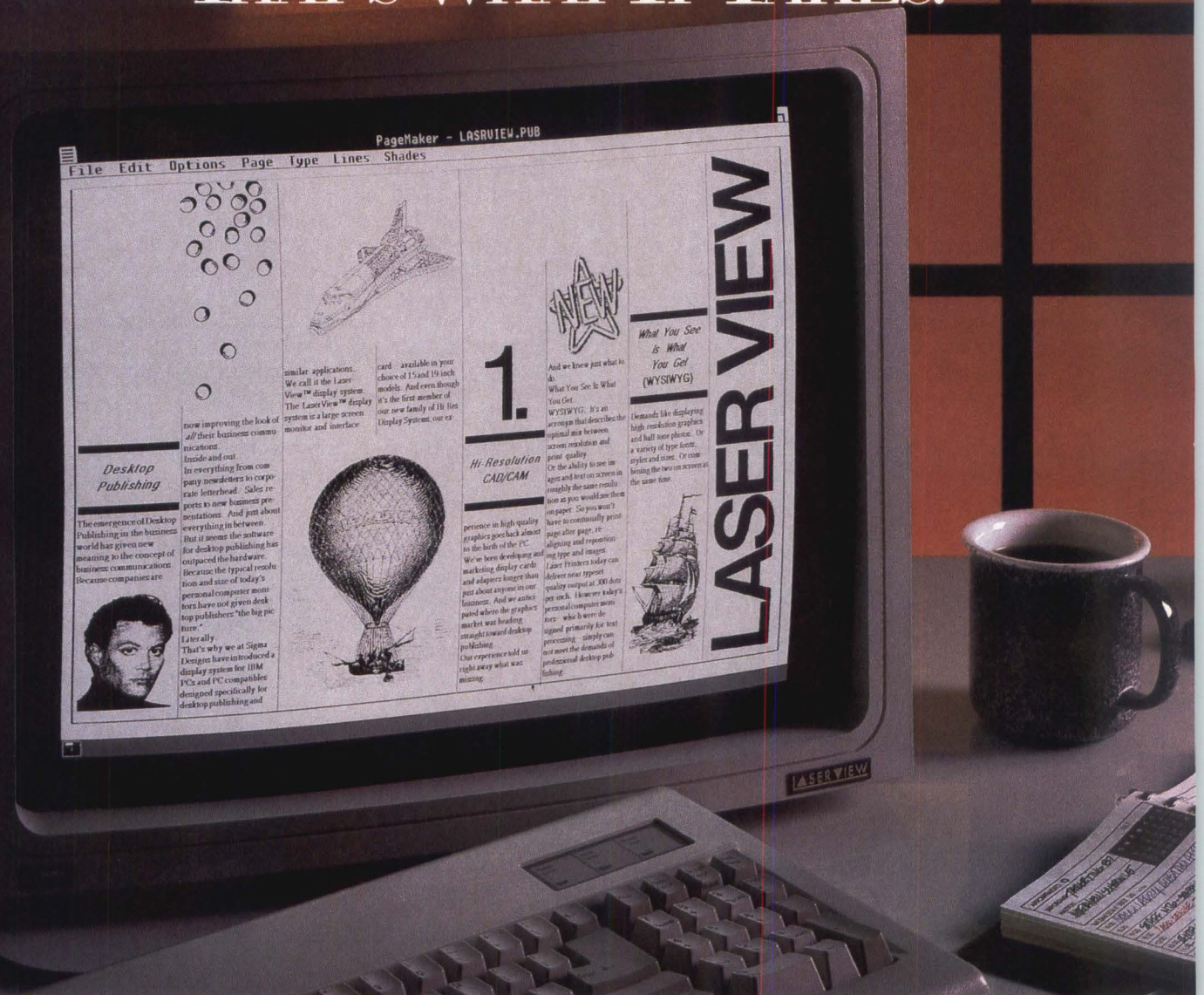

At least in order to get on-screen resolution of this quality. And to get an accurate representation of what a facing-page spread—one that you can actually read—will look like when it's printed.

Introducing the LaserView™ Display System.

From Sigma Designs.

LaserView consists of a large screen monitor, complete with display adapter, available in your choice of 15 and 19" inch models. Big enough to put everything from simple

graphs and charts to Desktop Publishing to CAD in an entirely new perspective. And at virtually full size.

Offering a *noninterlaced* screen resolution of 1664 x 1200—equal to 8 EGA™-sized or 11 Macintosh™ screens—LaserView's "easy-on-the-eyes" paper-white display brings workstation-quality graphics and text to the PC level. It can even generate *four levels of gray* for increased on-screen detail in photos and drawings.

LaserView works with all programs that run under

Windows™ and GEM™ including programs like Aldus Pagemaker™ and Ventura Publisher™—plus familiar PC programs like Lotus 1-2-3™ and AutoCAD™. We've even included a copy of PC Paintbrush Plus® to help you get started with LaserView.

So call Sigma Designs. Because if you're serious about making it to the big screen, Sigma Designs has what it takes today.

LaserView.

**CIRCLE NO. 40 ON INQUIRY CARD**  
See us at Spring Comdex, Atlanta, Booth #424



Sigma Designs Inc.  
46501 Landing Parkway  
Fremont, CA 94538  
415.770.0100

S I G M A D E S I G N S

Trademarks: LaserView: Sigma Designs, Inc.; EGA: International Business Machines Corporation; Macintosh: Apple Computer; Windows: Microsoft, Inc.; GEM: Digital Research Inc.; Pagemaker: Aldus Corporation; Ventura Publisher: Ventura Software Inc.; Lotus 1-2-3: Lotus Development Corporation; AutoCAD: AutoDesk Inc.; PC Paintbrush Plus: Z-Soft Corporation. \*For commercial use only.

## DATABASE DEVELOPMENT TOOL EVALUATION

| Package name<br>Company                                                                                                                               | Price (\$)<br>(RT fee) | SQL                 | Text store                 | Text editor    | Interpreter | Compiled/called |                |       |                              |    | General attractiveness                                     | Notes |
|-------------------------------------------------------------------------------------------------------------------------------------------------------|------------------------|---------------------|----------------------------|----------------|-------------|-----------------|----------------|-------|------------------------------|----|------------------------------------------------------------|-------|
|                                                                                                                                                       |                        |                     |                            |                |             | C-fh            | X              | C-sub | Nonprocedural/<br>procedural |    |                                                            |       |
| dbVista <sup>6</sup> , dbQuery <sup>8,7</sup><br><b>Raima</b>                                                                                         | 490 (0)                | Y<br>(no sub-query) | to memory                  | N              | N           | Y               | Y <sup>5</sup> | Y     | M1                           | 7  | advantages of a network database; has limited SQL          |       |
| dBSQL<br><b>Word Tech Systems</b>                                                                                                                     | 349 (0)                | Y                   | Y <sup>1</sup>             | Y <sup>2</sup> | Y           | N               | Y              | Y     | M1                           | 9  | ran in Derby                                               |       |
| pBase<br><b>4B Associates</b>                                                                                                                         | 35 (0)                 | Y                   | N                          | N              | Y           | N               | N              | N     | M1                           | 7  | 256K-byte version public domain                            |       |
| c-tree <sup>6</sup> , CQL <sup>7,8,9</sup> , Vitamin C <sup>9</sup> , C-Terp <sup>10</sup><br><b>FairCom; Kurtzberg; Creative Programming; Gimpel</b> | 900 (0)                | Y                   | to compiler limit          | Y              | Y           | Y               | Y <sup>5</sup> | Y     | M1, M2                       | 10 | combination of packages                                    |       |
| Phact <sup>6</sup> , Pquery <sup>8</sup> , Preport <sup>7</sup><br><b>Phact Associates</b>                                                            | 965 (0)                | Y                   | 9,999                      | NA             | Y-N         | Y               | Y              | Y     | M2                           | 7  | compare with Btrieve, etc., and c-tree, etc.               |       |
| dBMAN<br><b>Versasoft</b>                                                                                                                             | 295 (0)                | N                   | N                          | N              | Y           | N               | N              | N     | M2                           | 5  | much faster than dBASE III, otherwise very similar         |       |
| c-tree <sup>6</sup> , r-tree <sup>7</sup><br><b>Faircom</b>                                                                                           | 650 (0)                | N                   | to compiler limit          | N              | N           | Y               | Y              | Y     | M2                           | 7  | faster than Btrieve, portable                              |       |
| dBx Translation<br><b>Programmers' Shop</b>                                                                                                           | (0)                    | N                   | N                          | N              | N           | Y               | Y <sup>5</sup> | Y     | M2                           | 7  | translates dBASE II code into C source code                |       |
| CLARION<br><b>Barrington Systems</b>                                                                                                                  | 395 (0)                | N                   | 80-char. scroll, 65K bytes | Y              | Y-N         | N               | Y              | Y     | M2                           | 9  | COBOL, PL/1-like, financial orientation, many facilities   |       |
| Paradox<br><b>Ansa</b>                                                                                                                                | 695 (9.95 per 250)     | Y (QBE)             | N                          | N              | N           | Y               | N              | NA    | M2                           | 6  | faster than dBASE III, new PAL has many features           |       |
| Btrieve <sup>6</sup> , Xtrieve <sup>8</sup> , Rtrieve <sup>7</sup><br><b>Softcraft</b>                                                                | 635 (0-Btrieve)        | N                   | 4,090                      | N              | Y-N         | Y               | Y              | Y     | M2                           | 6  | "crash-proof," interface to BASIC as well as C             |       |
| dBcIII <sup>6</sup><br><b>Lattice</b>                                                                                                                 | 250/500 (0)            | N                   | Y <sup>1</sup>             | Y <sup>2</sup> | N           | Y               | Y              | Y     | N                            | 4  | standalone ISAM for C, 100% dBASE III compatible           |       |
| R&R <sup>7</sup><br><b>Concentric Data</b>                                                                                                            | 99 (0)                 | N                   | Y <sup>1</sup>             | Y <sup>2</sup> | Y           | N               | N              | N     | M1                           | 3  | like Rtrieve, for dBASE III                                |       |
| C-Index <sup>6</sup><br><b>Trio Systems</b>                                                                                                           | 395 (0)                | N                   | 16K bytes                  | N              | N           | Y               | Y <sup>5</sup> | Y     | N                            | 2  | variable length for both key and non-key fields            |       |
| TAS-PLUS<br><b>Business Tools</b>                                                                                                                     | 69/199 (0)             | N                   | 10K bytes                  | NA browse      | Y           | N               | Y              | NA    | M1                           | 5  | just came out with applications developer                  |       |
| Gennifer<br><b>Bytel</b>                                                                                                                              | 395 (0)                | N                   | Y <sup>1</sup>             | Y <sup>2</sup> | Y           | N               | N              | N     | Y                            | 4  | front-end to dBASE III for easier applications development |       |
| File Manager<br><b>Integrated Data Technology</b>                                                                                                     | 34.95 (0)              | N                   | NA                         | NA             | Y menu      | N               | N              | N     | Y                            | 3  | relatively unknown package                                 |       |
| asm Tree <sup>6</sup><br><b>BC Associates</b>                                                                                                         | 395 (0)                | N                   | NA                         | N              | N           | Y               | Y              | Y     | N                            | 3  | fast because in assembler, relatively unknown package      |       |
| BTree <sup>6</sup><br><b>SoftFocus</b>                                                                                                                | 75 (0)                 | N                   | Y 32K bytes                | N              | N           | Y               | Y              | Y     | N                            | 4  | no limit to key size except available memory               |       |

<sup>1</sup>dBASE III has a memo field that is unlimited in size but not part of the searchable database and outside of the B-tree.

<sup>2</sup>dBASE III has an internal editor that can deal with up to 5K bytes of the memo field; otherwise, the field can be edited by an outside word-processing package.

<sup>3</sup>One can add Lattice's dBcIII to call the dBASE III database from C programs.

<sup>4</sup>Languages are ideal for library-search problems, and it is unnecessary to have SQL except for internal database control.

<sup>5</sup>Source code provided (aids in transportability of application).

<sup>6</sup>B-tree file manager (no query, screen I/O or report generation).

<sup>7</sup>Report generator for a particular file manager or structure.

<sup>8</sup>Query facility for a particular file manager or structure.

<sup>9</sup>Windowing package for screen I/O from within C. See also Panel, Windows for C and Greenleaf.

<sup>10</sup>C interpreter, may add to any C environment package to get interpreter. See also Interactive C and Run/C.

M1: Application language is mixed but predominantly a good nonprocedural language.

M2: Application language is mixed and highly procedural.

## DATABASE DEVELOPMENT TOOL EVALUATION

| Package name<br>Company                                    | Price (\$)<br>(RT fee)              | SQL                      | Text store        | Text editor    | Interpreter | Compiled/called |                |                 |          | Nonprocedural/<br>procedural/<br>General | attractiveness                                                                    | Notes |
|------------------------------------------------------------|-------------------------------------|--------------------------|-------------------|----------------|-------------|-----------------|----------------|-----------------|----------|------------------------------------------|-----------------------------------------------------------------------------------|-------|
|                                                            |                                     |                          |                   |                |             | C-fn            | X              | C-sub           |          |                                          |                                                                                   |       |
| CBTree <sup>6</sup><br>Micro Computing                     | 99 (0)                              | N                        | Y                 | N              | N           | Y               | Y <sup>5</sup> | Y               | N        | 4                                        | block retrieval calls, unlimited key length and record length                     |       |
| Any dBASE III compiler (and dBASE III Plus by Ashton-Tate) | 800 (0)                             | N                        | Y <sup>1</sup>    | Y <sup>2</sup> | Y           | N <sup>3</sup>  | Y              | Y               | M2       | 7                                        | examples: Quicksilver (WordTech), Clipper (Nantucket) and FoxBASE+ (Fox)—all fast |       |
| The Creator<br>Advanced Development Technology             | 99 (0)                              | N                        | Y                 | NA             | Y           | NA              | NA             | Y               | M2       | 6                                        | relatively unknown package                                                        |       |
| QINT<br>Database Systems                                   | 995 (995)                           | Y                        | Y<br>32K bytes    | Y              | Y           | N               | Y              | NA              | Y        | 9                                        | IBM DB2 equivalent, ran in Derby                                                  |       |
| Knowledgeman II<br>MDBS                                    | 500 (50)                            | Y                        | Y                 | Y              | Y           | Y               | NA             | Y               | Y        | 9                                        | very comprehensive                                                                |       |
| INFORMIX<br>Informix Software                              | 995 (395)                           | Y                        | Y<br>32K bytes    | Y              | Y           | Y               | Y              | Y               | M1       | 10                                       | UNIX strength, VMS; mainframe migration                                           |       |
| XDB<br>Software Systems Technology                         | 395 (100)                           | Y                        | 1,000             | Y              | Y           | Y               | Y-N            | Y               | M1       | 7                                        | ran in Derby, IBM DB2 equivalent                                                  |       |
| Ingres<br>Relational Technology                            | 1,200 plus 400 (application); (300) | Y                        | 2,000             | Y              | Y           | Y               | Y              | Y               | M1       | 7                                        | ran in Derby, IBM DB2 equivalent, mainframe migration                             |       |
| ORACLE<br>Oracle/AT&T                                      | 1,500 (350)                         | Y                        | Y<br>64K bytes    | NA             | Y           | Y               | Y              | many            | M1       | 10                                       | ran in Derby; IBM DB2 equivalent; IBM, DEC, DG, AT&T, etc.; mainframe migration   |       |
| R:Base 5000<br>Microrim                                    | 700 (450 per 5)                     | Y                        | 1,500, 4,092      | N              | ?           | N               | Y              | Pascal, FORTRAN | M1       | 7                                        | Focus-like                                                                        |       |
| dBASE III Plus<br>Ashton-Tate                              | 500 (250 per 5)                     | N                        | Y <sup>1</sup>    | Y <sup>2</sup> | Y           | N               | N              | Y               | M2       | 5                                        | no compiler                                                                       |       |
| Revelation<br>Cosmos                                       | 950 (200)                           | N                        | Y<br>64K          | Y              | Y           | N               | Y              | Y               | M1       | 6                                        | text DBMS, oriented toward end users                                              |       |
| Progress<br>Data Language                                  | 675 (200)                           | N                        | Y<br>2K bytes     | NA             | Y           | N               | N              | NA              | Y        | 8                                        | ran in Derby, Focus-like                                                          |       |
| ZIM<br>Zanthe                                              | 750 (150)                           | N                        | Y<br>8,192        | Y              | Y           | N               | Y              | NA              | M1       | 10                                       | Focus-like, but relational with variable field editor                             |       |
| Q-Pro<br>Q-N-E International                               | 595 (NA)                            | N                        | N                 | N              | Y           | ?               | Y              | Assembly        | M1       | 7                                        | business-oriented, dBASE III-based                                                |       |
| Dataflex<br>Data Access                                    | 750 (200)                           | N                        | N                 | N              | Y           | N               | Y              | Pascal          | M2       | 7                                        | supports multiple environments                                                    |       |
| PC Focus<br>Information Builders                           | 1,200 (400)                         | N                        | N                 | N              | Y           | Y               | N              | Y               | Y, M1    | 8                                        | powerful business tool, network, excellent report generator, mainframe migration  |       |
| DataEase<br>Software Solutions                             | 600 (600)                           | N                        | 4K bytes per form | Y              | Y           | N               | N              | Y               | menu, M1 | 8                                        | filer integrated with WP, applications developer soon                             |       |
| Q&A<br>Symantec                                            | 300 (300)                           | N<br>Natural/<br>Keyword | Y                 | Y<br>in WP     | Y           | N               | N              | N               | Y        | 2                                        | cannot write applications, can have preset reports                                |       |

<sup>1</sup>dBASE III has a memo field that is unlimited in size but not part of the searchable database and outside of the B-tree.

<sup>2</sup>dBASE III has an internal editor that can deal with up to 5K bytes of the memo field; otherwise, the field can be edited by an outside word-processing package.

<sup>3</sup>One can add Lattice's dBCIII to call the dBASE III database from C programs.

<sup>4</sup>Languages are ideal for library-search problems, and it is unnecessary to have SQL except for internal database control.

<sup>5</sup>Source code provided (aids in transportability of application).

<sup>6</sup>B-tree file manager (no query, screen I/O or report generation).

<sup>7</sup>Report generator for a particular file manager or structure.

<sup>8</sup>Query facility for a particular file manager or structure.

<sup>9</sup>Windowing package for screen I/O from within C. See also Panel, Windows for C and Greenleaf.

<sup>10</sup>C interpreter, may add to any C environment package to get interpreter. See also Interactive C and Run/C.

M1: Application language is mixed but predominantly a good nonprocedural language.

M2: Application language is mixed and highly procedural.

# Tandy has more experience in XENIX® multiuser systems than any other VAR vendor.

When it comes to selling XENIX-based multiuser systems, you need Tandy on your side. That's because Tandy has one of the largest installed base of XENIX systems in the world. And years of experience that put us head and shoulders above our competitors.

That's why it is to your advantage to become a Tandy Value-Added Reseller. Once you do, you will profit from our proven experience and expertise in XENIX systems.

#### Multiuser efficiency

The high-performance Tandy 3000 HD and versatile XENIX System V operating system (based on UNIX® System V, the standard of the UNIX world),

are the keys to making total of office automation systems development more efficient and cost effective for your customers.

The Tandy 3000 HD is IBM PC/AT® compatible and has a 28ms 40 MB hard disk drive. With the 3000 HD's power, a XENIX operating system and inexpensive display terminals, you will be able to custom-tailor multiuser system solutions to meet your customers' needs. And that's a competitive edge that will help you grow your business.

#### Advanced 286 technology

Based on the 16-bit Intel® 80286 microprocessor, the 3000 HD operates at 8 MHz and features 640K main memory (expandable to 12 MB). A high-capacity 5<sup>1</sup>/<sub>4</sub>"

disk drive reads both 1.2 MB and 360K formats, allowing the 3000 HD to run either IBM® PC or PC/AT software.

**Ready now for Tandy VARs**  
XENIX-based Tandy 3000 HD multiuser systems are available through the Tandy VAR Program. A program that includes the most complete computer product line in the industry, competitive pricing, strong after market support, fast order processing, plus a leasing program exclusively for Tandy VARs.\*

For more information on Tandy's Value-Added Resale program and hot-selling industry-standard multiuser systems, write or give us a call today!



**Tandy Corporation**

**Value-Added Resale**

1400 One Tandy Center, Fort Worth, Texas 76102 (817) 338-2387

\*Tandy VAR Leasing Program administered by Dana Commercial Credit. XENIX/Registered TM Microsoft Corp. UNIX/Registered TM AT&T. IBM PC/AT/Registered TM International Business Machines Corp.

CIRCLE NO. 41 ON INQUIRY CARD





## DATABASE DEVELOPMENT TOOL EVALUATION

| Package name<br>Company                                  | Price (\$)<br>(RT fee) | SQL            | Text store                  | Text editor | Compiled/called |      |   | C-sub | Nonprocedural/<br>procedural | General<br>attractiveness | Notes                                                                                    |
|----------------------------------------------------------|------------------------|----------------|-----------------------------|-------------|-----------------|------|---|-------|------------------------------|---------------------------|------------------------------------------------------------------------------------------|
|                                                          |                        |                |                             |             | Interpreter     | C-1h | X |       |                              |                           |                                                                                          |
| Palantir File<br><b>Palantir Software</b>                | 395<br>(237)           | N              | Data<br>bridge<br>to WP     | in WP       | Y               | N    | N | N     | Y                            | 3                         | integrated with WP                                                                       |
| Open Access II<br><b>Software Products International</b> | 595<br>(not<br>yet)    | N              | data<br>query<br>from<br>WP | in WP       | Y               | N    | N | N     | Y<br>menus                   | 3                         | like Palantir File and more like Rapid<br>File (Ashton-Tate)                             |
| Dayflo<br><b>Dayflo</b>                                  | 395<br>(395)           | N <sup>4</sup> | Y                           | Y           | Y               | N    | N | N     | M1                           | 6                         | broad TBMS (text-based management<br>system)                                             |
| Marcon<br><b>Airs</b>                                    | 1,495<br>(1,495)       | N <sup>4</sup> | Y                           | Y           | Y               | N    | N | N     | Y                            | 5                         | powerful TBMS                                                                            |
| InMagic<br><b>InMagic</b>                                | 975<br>(975)           | N <sup>4</sup> | Y                           | Y           | Y               | N    | N | N     | Y                            | 5                         | TBMS, slow                                                                               |
| AskSAM<br><b>Seaside Software</b>                        | 200<br>(200)           | N <sup>4</sup> | Y                           | Y           | Y               | N    | N | N     | Y                            | 5                         | TBMS, fast                                                                               |
| Citation<br><b>Eagle Enterprises</b>                     | 185<br>(185)           | N <sup>4</sup> | Y                           | Y           | Y               | N    | N | N     | Y                            | 6                         | information-oriented                                                                     |
| ZyIndex<br><b>ZyLab</b>                                  | 195/695<br>(195/695)   | N <sup>4</sup> | Y<br>unlimited              | Y<br>browse | Y               | N    | N | N     | Y                            | 7                         | Lockheed Dialog-like, lexical, for law<br>firms, etc.                                    |
| 4-1-1<br><b>Select Infor-<br/>mation Systems</b>         | 149<br>(149)           | N <sup>4</sup> | Y                           | Y<br>browse | Y               | N    | N | N     | Y                            | 7                         | more limited searching than ZyIndex,<br>lexical                                          |
| FYI 3000<br><b>Software Marketing</b>                    | 395<br>(395)           | N <sup>4</sup> | Y                           | Y<br>browse | Y               | N    | N | N     | Y                            | 7                         | lexical                                                                                  |
| Notebook II<br><b>Pro/Tem</b>                            | 189<br>(189)           | N <sup>4</sup> | Y                           | Y           | Y               | N    | N | N     | Y                            | 4                         | flat file with variable length fields;<br>TDBS; has footnote, bibliography<br>capability |

<sup>1</sup>dBASE III has a memo field that is unlimited in size but not part of the searchable database and outside of the B-tree.

<sup>2</sup>dBASE III has an internal editor that can deal with up to 5K bytes of the memo field; otherwise, the field can be edited by an outside word-processing package.

<sup>3</sup>One can add Lattice's dBCIII to call the dBASE III database from C programs.

<sup>4</sup>Languages are ideal for library-search problems, and it is unnecessary to have SQL except for internal database control.

<sup>5</sup>Source code provided (aids in transportability of application).

<sup>6</sup>B-tree file manager (no query, screen I/O or report generation).

<sup>7</sup>Report generator for a particular file manager or structure.

<sup>8</sup>Query facility for a particular file manager or structure.

<sup>9</sup>Windowing package for screen I/O from within C. See also Panel, Windows for C and Greenleaf.

<sup>10</sup>C interpreter, may add to any C environment package to get interpreter. See also Interactive C and Run/C.

M1: Application language is mixed but predominantly a good nonprocedural language.

M2: Application language is mixed and highly procedural.

## Companies mentioned in the table

### Advanced Development Technologies

2720 N. 68th St.  
Scottsdale, Ariz. 85257  
(800) 528-6060  
**Circle 332**

### Airs Inc.

335 Paint Branch Drive  
College Park, Md. 20742  
(301) 454-2022  
**Circle 333**

### Ansa Software

1301 Shore Way Road  
Belmont, Calif. 94002  
(415) 595-4469  
**Circle 334**

### Ashton-Tate

10150 W. Jefferson Blvd.  
Culver City, Calif. 90230  
(213) 204-5570  
**Circle 335**

### Barrington Systems Inc.

150 E. Sample Road  
Pompano Beach, Fla. 33064  
(305) 785-4555  
**Circle 336**

### BC Associates

3261 N. Harbor  
Fullerton, Calif. 92635  
(714) 526-5151  
**Circle 337**

### Business Tools Inc.

4038-B 128th Ave., S.E.  
Bellevue, Wash. 98006  
(206) 644-2015  
**Circle 338**

### Bytel Corp.

1029 Solano Ave.  
Berkeley, Calif. 94706  
(415) 527-1157  
**Circle 339**

### Concentric

**Data Systems Inc.**  
18 Lyman St.  
Westboro, Mass. 01581  
(617) 366-9035  
**Circle 340**

### Cosmos Inc.

3633 136th Place S.E.  
Bellevue, Wash. 98006  
(206) 643-9898  
**Circle 341**

### Creative Programming

Box 112097  
Carrollton, Texas 75011  
(214) 245-6090  
**Circle 342**

### Data Access Corp.

8525 S.W. 129 Terrace  
Miami, Fla. 33156  
(305) 238-0012  
**Circle 343**

### Data Language Corp.

47 Manning Road  
Billerica, Mass. 01821  
(617) 663-5000  
**Circle 344**

### Database Systems Corp.

1118 E. Missouri Ave.  
Phoenix, Ariz. 85014  
(602) 265-5968  
**Circle 345**

### Dayflo Inc.

17701 Mitchell Ave. N.  
Irvine, Calif. 92714  
(714) 476-3044  
**Circle 346**

*continued on following page.*

Companies mentioned continued from previous page.

**Eagle Enterprises**  
2375 Bush St.  
San Francisco, Calif. 94115  
(415) 346-1249  
**Circle 347**

**FairCom**  
2606 Johnson Drive  
Columbia, Mo. 65203  
(314) 445-6833  
**Circle 348**

**4B Associates**  
2518 Curran Court  
Pinole, Calif. 94564  
**Circle 349**

**Fox Software Inc.**  
27475 Holiday Lane  
Perrysburg, Ohio 43551  
(419) 874-0162  
**Circle 350**

**Information Builders Inc.**  
1250 Broadway  
New York, N.Y. 10001  
(212) 736-4433  
**Circle 351**

**Informix Software Inc.**  
4100 Bohannon Drive  
Menlo Park, Calif. 94025  
(415) 322-4571  
**Circle 352**

**InMagic Inc.**  
238 Broadway  
Cambridge, Mass. 02139  
(617) 661-8124  
**Circle 353**

**Integrated Data Technology Inc.**  
4775 Bunchberry Lane  
Colorado Springs, Colo. 80917  
(303) 488-2583  
**Circle 354**

**Kurtzberg Computer Systems**  
41-19 Bell Blvd.  
Bayside, N.Y. 11361  
(718) 229-4540  
**Circle 355**

**Lattice Inc.**  
P.O. Box 3072  
Glen Ellyn, Ill. 60138  
(312) 858-7950  
**Circle 356**

**Micro Computing Services**  
2108C Gallows Road  
Vienna, Va. 22180  
(703) 893-0118  
**Circle 357**

**Micro Data Base Systems Inc. (MDBS)**  
P.O. Box 240  
Lafayette, Ind. 47902  
(317) 463-2581  
**Circle 358**

**Microrim**  
3925 159th Ave. N.E.  
Redmond, Wash. 98052  
(206) 885-2000  
**Circle 359**

**Nantucket Corp.**  
5995 S. Sepulveda Blvd.  
Culver City, Calif. 90230  
(213) 251-7923  
**Circle 360**

**Oracle Corp.**  
20 Davis Drive  
Belmont, Calif. 94002  
(800) 345-DBMS  
**Circle 361**

**Palantir Software**  
12777 Jones Road  
Houston, Texas 77070  
(713) 955-8880  
**Circle 362**

**Phact Associates Inc.**  
225 Lafayette St.  
New York, N.Y. 10012  
(213) 459-3689  
**Circle 363**

**The Programmers Shop**  
128 Rockland St.  
Hanover, Mass. 02339-2223  
(617) 826-7531  
**Circle 364**

**Pro/Tem Software Inc.**  
1136 Saranap Ave.  
Walnut Creek, Calif. 94595  
(415) 947-1000  
**Circle 365**

**Q-N-E International**  
136 Granite Hill Court  
Langhorne, Pa. 19047  
(215) 968-5966  
**Circle 366**

**Raima Corp.**  
3055 112th Ave., N.E.  
Bellevue, Wash. 98004  
(800) 327-2462  
**Circle 367**

**Relational Technology Inc.**  
1080 Marina Village Parkway  
Alameda, Calif. 94501  
(415) 748-3316  
**Circle 368**

**Seaside Software**  
119 S. Washington St.  
Perry, Fla. 32347  
(904) 584-6590  
**Circle 369**

**Select Information Systems Inc.**  
919 Sir Francis Drake Blvd.  
Kentfield, Calif. 94904  
(415) 459-4003  
**Circle 370**

**SoftCraft Inc.**  
P.O. Box 9802  
Austin, Texas 78766  
(512) 346-8380  
**Circle 371**

**Softfocus**  
1343 Stanbury Drive  
Oakville, Ontario  
L6L 2J5, Canada  
(416) 825-0903  
**Circle 372**

**Software Marketing Associates**  
4615 Bee Caves Road  
Austin, Texas 78746  
(512) 327-2882  
**Circle 373**

**Software Products International**  
10240 Sorrento Valley Road  
San Diego, Calif. 92121  
(619) 450-1526  
**Circle 374**

**Software Solutions Inc.**  
12 Cambridge Drive  
Trumbull, Conn. 06611  
(203) 374-8000  
**Circle 375**

**Software Systems Technology Inc.**  
7100 Baltimore Ave.  
College Park, Md. 20740  
(301) 779-5486  
**Circle 376**

**Symantec**  
10201 Torre Ave.  
Cupertino, Calif. 95014  
(408) 253-9600  
**Circle 377**

**Trio Systems**  
2210 Wilshire Blvd.  
Santa Monica, Calif. 90403  
(213) 394-0796  
**Circle 378**

**Versasoft Corp.**  
723 Seawood Way  
San Jose, Calif. 95120  
(408) 723-9044  
**Circle 379**

**WordTech Systems Inc.**  
P.O. Box 1747  
Orinda, Calif. 94563  
(415) 254-0900  
**Circle 380**

**Zanthe Information Inc.**  
1200-38 Anares Drive  
Nepean, Ontario  
K2D 7V2, Canada  
(613) 727-1397  
**Circle 381**

**ZyLab Corp.**  
233 E. Erie St.  
Chicago, Ill. 60611  
(312) 642-2201  
**Circle 382**

## SOFTWARE SENTINEL-W™

**MUCH MORE THAN JUST PROTECTION**

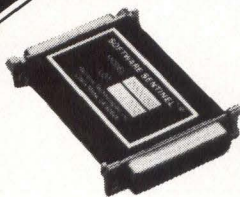

Stop unauthorized use of your software! From the leader in PC software protection comes a serial port product designed for the workstation, super micro and mini-computer markets. We supply the hardware key and detailed interface specifications; you design a port driver which locks the execution of your software to the hardware key. Your customers will appreciate the interface-free operation of this protection system, and you will appreciate the extra money in your coffers.

### SOFTWARE DEVELOPER BENEFITS

- Prohibits unauthorized use of software
- No need for copy protection
- Algorithm technique (never a fixed response)
- Virtually unbreakable

### INTERFACE REQUIREMENTS:

- 25 pin DB25P or DB25S
- R232/RS422/RS423

### SOFTWARE USER BENEFITS

- Unlimited backup copies
- Pocketsize key
- Transparent operations
- Transportable

### ONLY THREE SIGNALS USED:

- DTR & RTS from computer
- Signal ground
- DSR or optional DCD from SOFTWARE SENTINEL-W or external device



**RAINBOW TECHNOLOGIES, INC.**

**EVALUATION KIT AVAILABLE**

Telex 386078

17971 SKYPARK CIRCLE SUITE E, IRVINE, CA 92714

(714)261-0228

Interest Quotient (Circle One)  
High 492 Medium 493 Low 494

# We've got the most affordable, state-of-the-art data PBX you can buy. Period.

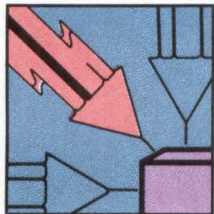

Sequel's SDC family is the first series of intelligent data switches to offer you all large network management features, whether you need a few or hundreds. Features like single sign-on, time-of-day clock, toggling, redundant power and logic, security call-back, and more.

### Think Small. Then Grow Big.

You can start out with as few as six local ports and expand to as many as 1,536, worldwide. □ Sequel's SDC family links together terminals, I/O ports, printers, modems, and any device that sends or receives data up to 19.2K bit/s. Without line drivers or multiplexers. Even at maximum usage, the 19.2K bit/s rate persists.

### Meet The Three.

The SDC 660 gives you a range of six to 60 ports. □ If you outgrow it, keep all the cards and buy the SDC 6192 chassis. Now you can grow to 192 ports. □ If you need to expand further, the SDC 6192 Network is the answer. Plug Sequel's local networking card into as many as 8 chassis and expand up to 1,536 lines.

### Break The \$100-Per-Port Barrier.

With all this to offer and more, our switch costs less than any other. The low \$100-per-port price begins at 30 ports.

### Find Out For Yourself.

Call today and we'll demonstrate to you why Sequel's SDC family is so fast, flexible, and affordable. And why Sequel means "We're What's Next."

### Standard Features Sampling

- *Port contention by name, number, or class*
- *Help menus*
- *Simultaneous toggling*
- *Priority queuing*
- *Auto baud*
- *Network status display*
- *Password-controlled protection*
- *Alternate destination routing*
- *Time-of-day reconfiguration*
- *Single sign-on*



# SEQUEL

Sequel Data Communications, Inc.  
5246 Greens Dairy Road Raleigh, NC 27604  
(919) 790-0300 Telex 5106002826

CIRCLE NO. 44 ON INQUIRY CARD

# Connect with network more

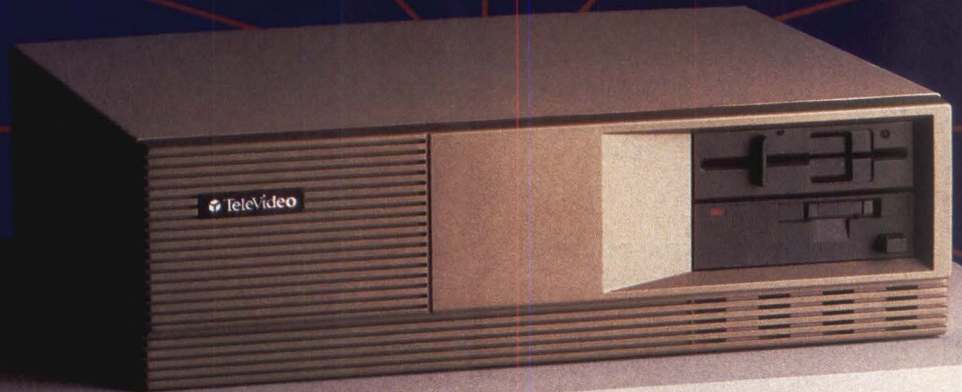

# TeleVideo and users, for less.



With our new PM/286 network server, you can put together high-performance networks for up to 40% less than the cost of comparable systems.

Look at the chart. You'll see the TeleVideo PM/286 network server beats the others and still gives you all the power you're looking for.

#### The performance you want.

Our intelligent network Starboard is designed with an Intel 8088 microprocessor maintaining high throughput, even as users are added. And the PM/286 is powered with the Intel 80286, 8MHz engine. So it can handle heavy loads, serving up files almost as fast as you can say "fetch."

#### The flexibility you need.

The PM/286 gives you more options.

It's easy to add up to 24 users. With the PM/286, you can use IBM PCs,\* other compatibles or TeleVideo diskless workstations. Our \$999 diskless workstations feature built-in network connections, so installation is as easy as plugging them in.

You can select the PM/286 model that best suits your application: 40 or 71 Mbyte hard disk (and room for more); 1 or 2 MB RAM; and up to 24 users. All models include a 1.2 MB floppy, 60 Mbyte streaming tape back-up, and a high resolution monitor.

#### Software savings, too.

We maximize your software investment because the PM/286 runs a custom version of Advanced NetWare/286,\* and is compatible with virtually any single user or multi-user application written for MS DOS, NetWare or NETBIOS. We also support the key programming languages.

#### Reliability you can count on.

The PM/286 is built on TeleVideo's five years experience in the multi-

user network business, with over 87,000 workstations attached to TeleVideo file servers. *Plus, it's backed with our new, unmatched ONSITE warranty service.*

#### Make the right connection.

Now's the time to find out just how

much you'll save with the new TeleVideo PM/286 network server.

Call your TeleVideo representative, or 1-800-835-3228 today for more information, and to find out about the TeleVideo seminar coming to your area soon.

Make the best price/performance connection. Connect with TeleVideo.

|                         | COST PER USER |                |
|-------------------------|---------------|----------------|
|                         | 8 User System | 16 User System |
| TeleVideo PM/286        | \$1,257       | \$ 926         |
| IBM Token Ring* Network | \$2,058       | \$1,474        |
| 3Com 3Server3 System*   | \$1,942       | \$1,268        |
| Novell* Server System   | \$2,119       | \$1,357        |

Prices are manufacturer list for comparable configurations with hard disk, tape drive, RAM memory, network interface boards and network operating system. Dedicated file server only. No workstation.

 **TeleVideo**<sup>®</sup>

TeleVideo Systems, Inc., 1170 Morse Avenue, Sunnyvale, CA 94088-3568, (408) 745-7760.  
 Regional offices: West (408) 745-7760; Southwest (714) 476-0244; South Central (214) 550-1060;  
 Southeast (404) 447-1231; Midwest (312) 397-5400; East (516) 496-4777; Northeast (617) 890-3282.  
 European offices: Amsterdam 31.2503.35444; Paris 33.1.4687.34.40; London 44.9905.6464.

\*IBM PC and Token Ring are trademarks of International Business Machines Corporation. Advanced NetWare/286 and Novell are trademarks of Novell, Inc., 3Com 3Server3 System is a trademark of 3Com Corporation. © 1987 TeleVideo Systems, Inc.

**CIRCLE NO. 45 ON INQUIRY CARD**

## Plug-In Parallel Processing

# HOW TO BUILD A REAL REAL-TIME PROCESSING SYSTEM

The best place to start is with Parallel Processing from Concurrent Computer Corporation. You get outstanding price/performance from a unique system architecture with an event-driven, real-time operating system that maximizes throughput, response and sheer computational power.

### Power and Growth

Concurrent Computer Corporation gives you all the power you need today and the ability to plug-in more when you need it. Without the high cost of replacing hardware or software.

Our flagship Model 3280 MPS lets you start at 6 MIPS and grow up to 33 MIPS just by plugging in additional processors. There's no need to reprogram; no obsolescence of your existing hardware.

### Computers With A Future

There are a lot more reasons why Parallel Processing makes sense. Like its built-in reliability. Like the way it accommodates I/O. The low life-cycle cost. They're the systems with a built-in future.

Want more?

**1-800-631-2154**

or write us at

Concurrent Computer Corporation  
2 Crescent Place  
Oceanport, NJ 07757

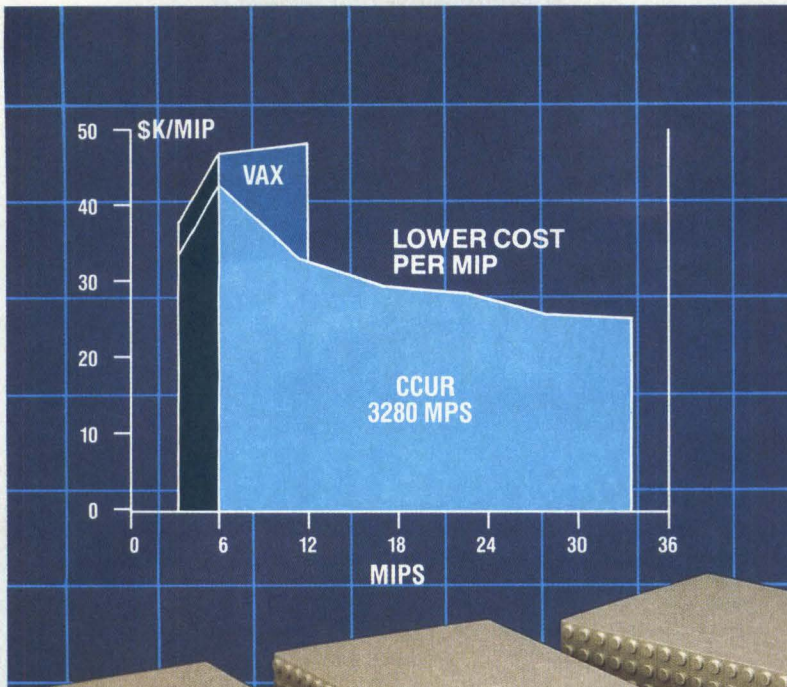

*Concurrent  
Computer Corporation*

CIRCLE NO. 46 ON INQUIRY CARD

# LANs LINK PCs TO MAINFRAMES

Local-area-network gateways to IBM SNA systems challenge conventional 3270 emulators, and LU 6.2 products threaten to rattle the micro-to-mainframe arena

**Jesse Victor**, Associate Editor

Links between local-area networks (LANs) and IBM Corp. Systems Network Architecture (SNA) systems menace the long-standing dominance of 3270 emulator boards and software as the preferred method of connecting IBM PCs and mainframes. Offered by both traditional

emulator vendors and LAN suppliers, such gateways are profiting from growing corporate acceptance of the advantages gained by connecting diverse (and dispersed) personal computers with LANs.

Gateway hardware and software combine a LAN's resource-sharing and configuration flexibility with timely access for personal comput-

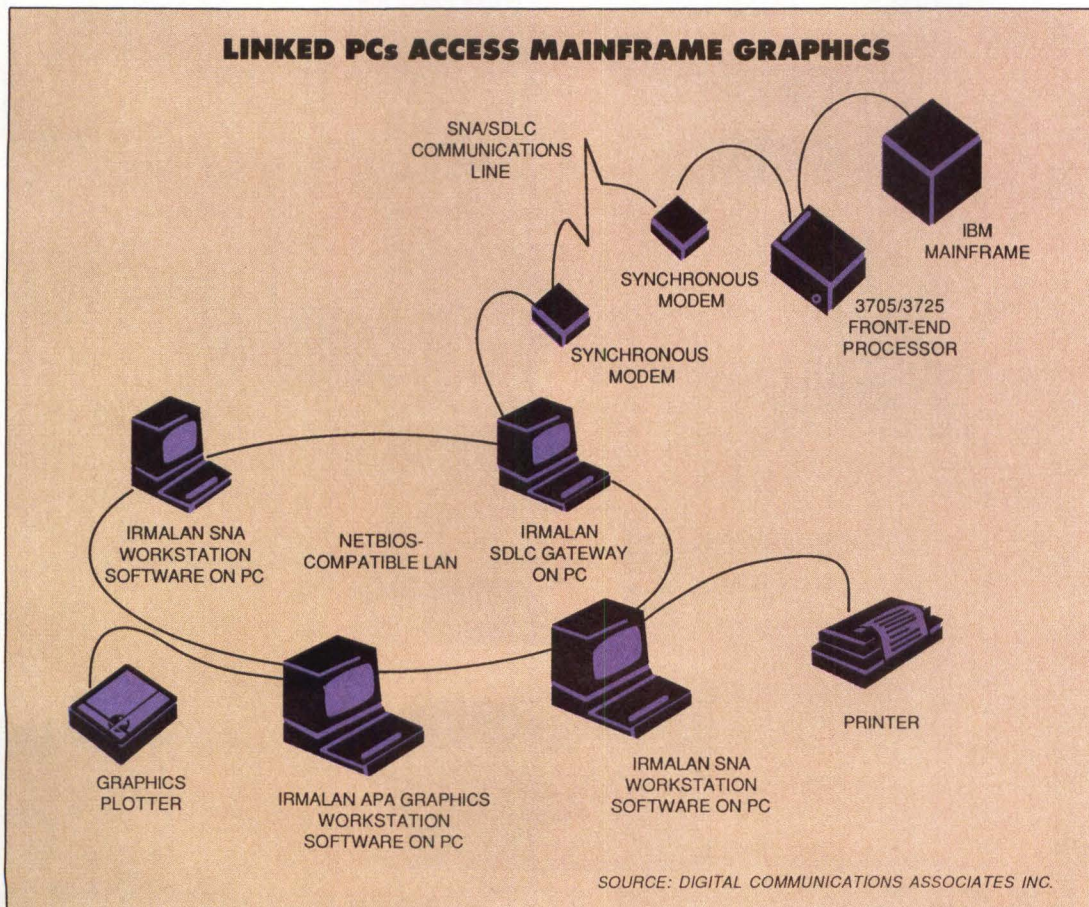

**IRMALAN/APA Graphics Workstation** software from DCA enables a PC on a NETBIOS-compatible LAN to display, store and print mainframe graphics via the SDLC Gateway remote link and synchronous modems.

ers to mainframe databases. And the emergence of LAN-SNA links coincides with a spate of marketing, distribution and merger agreements between 3270 board vendors and LAN companies. All this activity is reshaping the micro-to-mainframe market—and offers new and more powerful options to system integrators and OEMs.

Vendors of products that allow PCs to emulate 3270 terminals are responding to these new market forces with software that gives PCs on a LAN access to IBM mainframe data. The products combine traditional 3270-emulation functions, such as multiple host sessions and hot keying between emulator and MS-DOS modes. In many cases, they offer enhanced functionality such as access to mainframe graphics.

For example, Digital Communications Associates Inc., whose IRMA micro-to-mainframe board is a de facto hardware standard, supplies four products for PCs on an IBM Token-Ring

Network—one of which provides on-line mainframe APA (all points addressable) graphics capability.

The company's IRMALAN APA Graphics Workstation software enables a PC to display host applications written for the IBM 3179/G terminal and the 3270 PC/G and 3270 PC/GX that use the graphical data display manager (GDDM) 4.0 package. Users can store host graphics images on the PC or send them via the computer graphics interface (CGI) and virtual device interface (VDI) standards to a variety of printers or plotters.

**Gateways to versatility**

Hot-key capability enables users to switch among five concurrent host sessions and between MS-DOS and terminal-emulation modes. The package supports several of the company's file-transfer programs providing access to IBM mainframe time-sharing option

**Replacing an IBM 3247 cluster controller, Proteon's Network Interface System provides fast, full-screen response for 3270 terminals attached to a mainframe with the company's ProNET-10 or ProNET-80 LAN.**

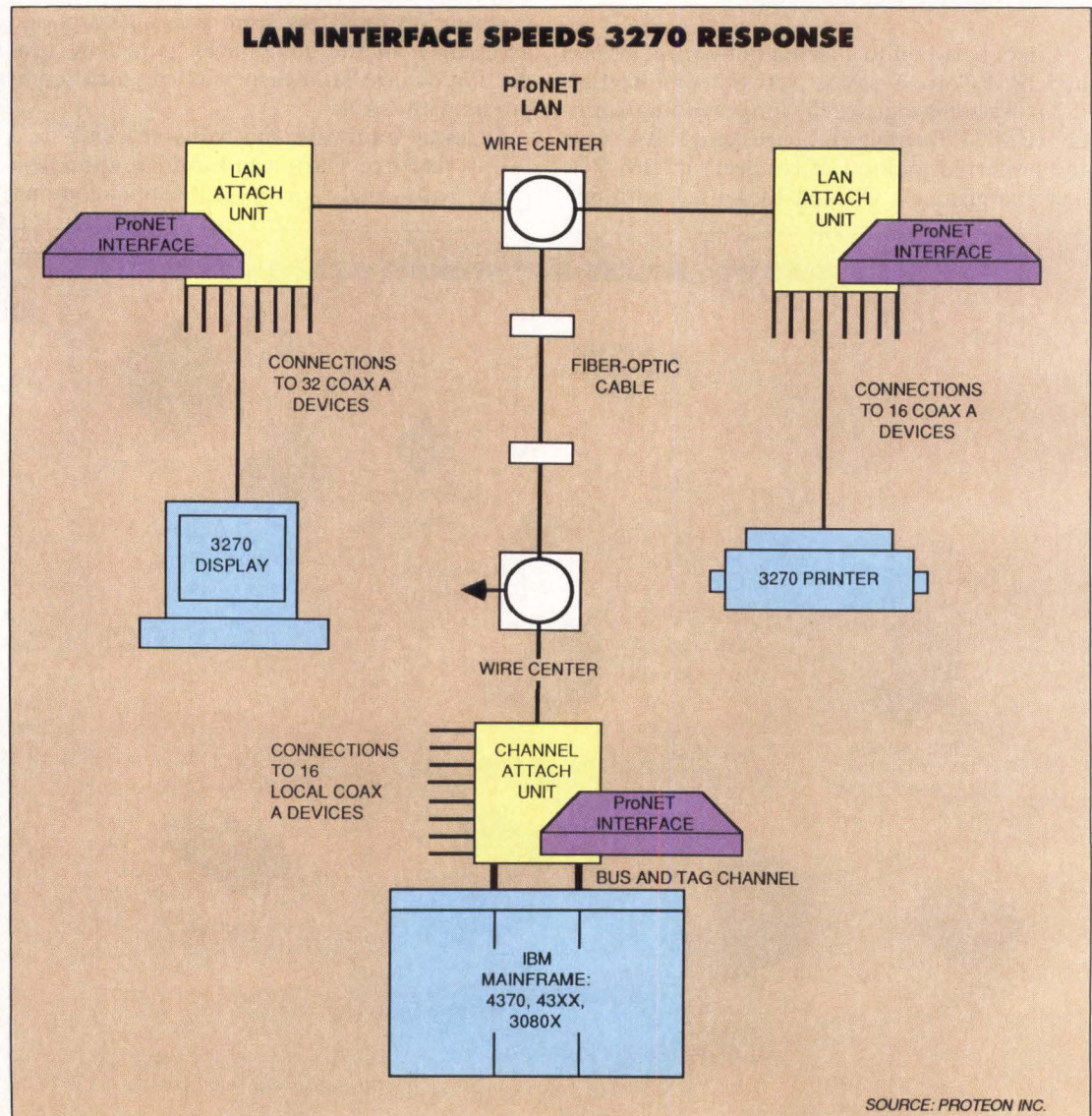

SOURCE: PROTEON INC.



**GATEWAY ACCELERATES IBM-DEC DATA SWAP**

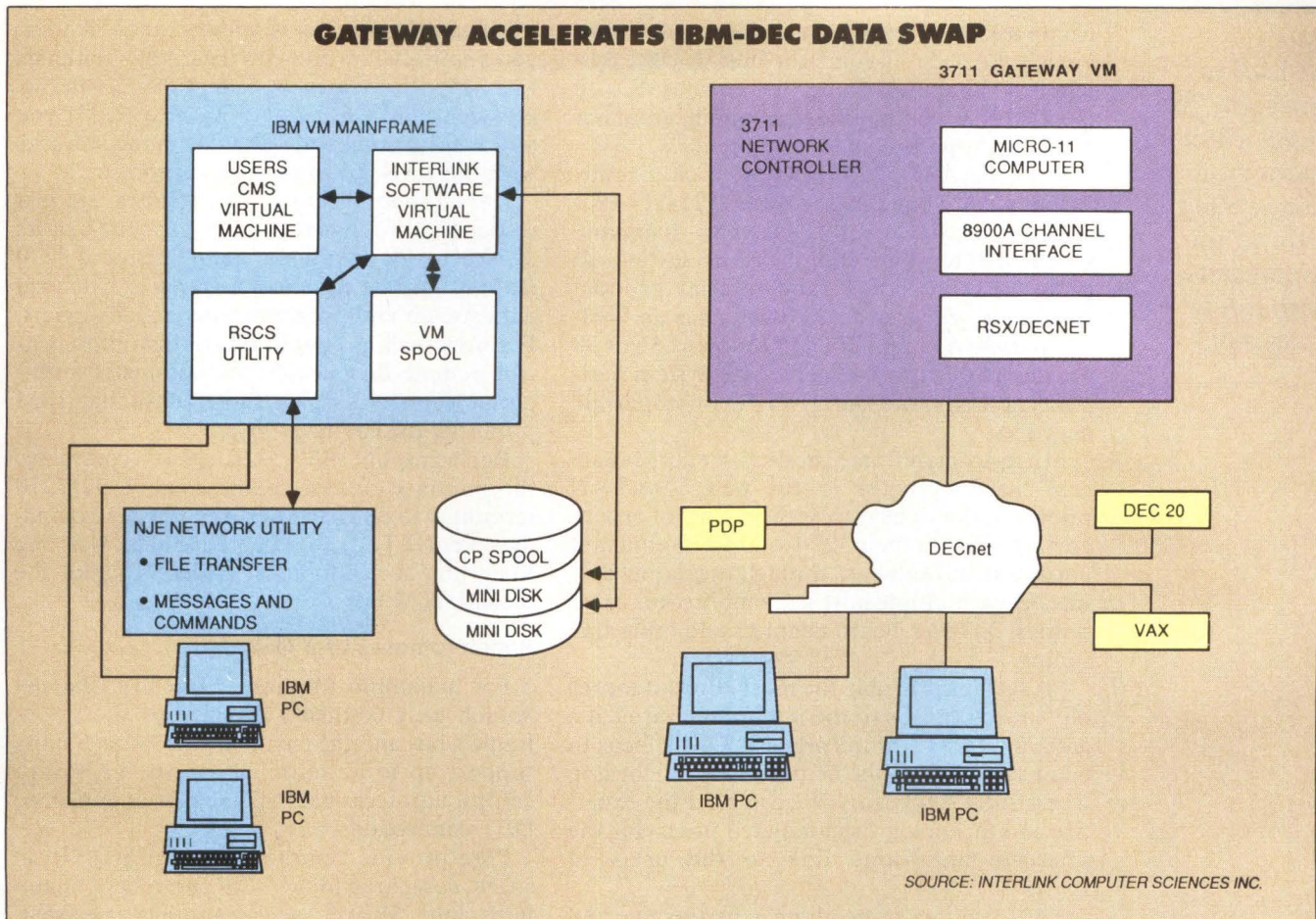

SOURCE: INTERLINK COMPUTER SCIENCES INC.

(TSO), conversational monitor system (CMS) and multiple virtual-storage/time-sharing option (MVS/TSO) environments.

IRMALAN SDLC (synchronous data link control) Gateway and DFT (distributed function terminal) Gateway hardware and software give PCs on a LAN remote and coaxial access, respectively, to the mainframe via a gateway PC. Emulating a 3274 communications controller, the SDLC gateway supports up to 32 concurrent host sessions. It uses a half-height card in the PC to connect to a synchronous modem attached to an IBM 3705 or 3725 front-end processor. The latter connects a card in the gateway PC via coax to a DFT port on an IBM 3274 controller.

Emulator vendor CXI Inc. emphasizes the advantages of its consistent application program interface (API) and user interfaces on all its micro-to-mainframe products and also the ease of upgrading its standard emulator hardware and software with gateways to LANs.

Take, for example, the PCOX/Gateway Coax upgrade or PCOX/Gateway 16 upgrade. Because they are soft-loaded (via flexible disk), they require neither changes in programmable ROM nor local or remote emulator boards in IBM PCs to enable the PCs to serve

as gateways to NETBIOS-compatible LANs. The Gateway 16 upgrade provides 16 host sessions for PCs on the LAN.

These products, and the equivalent stand-alone hardware and software packages, work with PCOX Gateway-WS workstation software installed in each PC on the LAN. Emulating 3278/9 terminals, 3270 PCs and 3287 printers, the workstation package furnishes concurrent windowing of up to five host sessions, one PC session and two notepads for each PC. Included file-transfer software communicates with customer information control system (CICS), CMS and TSO applications on the mainframe.

Charles Morel, CXI chairman and CEO, emphasizes the benefits of a consistent API and user interface over the company's range of micro-to-mainframe and gateway products. "The keyboard, display and printer control interfaces are all the same," explains Morel. "The advantage is that any application program you have written or purchased that runs in a coaxial environment will run in a remote environment as a workstation LAN gateway. It offers a wide choice of micro-to-mainframe application software and leverage of your existing software investment."

AST Research Inc. takes a somewhat differ-

**Two-way full-screen communications among IBM PCs or terminals connected to an IBM VM mainframe and various DEC computers is furnished by Interlink's 3711 Network Controller and associated software, part of its 3711 Gateway (VM) product.**

---

**'A LAN is probably the most efficient means of connecting PCs to the mainframe through a gateway.'**

---

ent approach to SNA/LAN connections. It provides a LAN-5250 emulator link to IBM System 3/X computers—one that enables PCs on the LAN to communicate, without emulator cards, with multiple host computers.

With the AST-5250/Gateway, each gateway PC on a LAN equipped with the 5251/11 Plus emulation card and software can distribute seven 5250 terminal and/or printer sessions to up to 21 other nodes. The gateway product comes with file-transfer software, has an IBM-compatible API for IBM's PC Support 36 or 38 packages and runs on AST's Star System Starlan-type LAN and on NETBIOS-compatible networks.

Micro-to-mainframe product vendors broadcast their strengths in the new SNA-LAN bridge market. They stress their years of experience in refining their 3270- and 5270-emulator hardware and software through upgrading user interfaces, multiple host sessions, hot-key capabilities, 3270 keyboard adapters and other fine tuning.

"A LAN is probably the most efficient means of connecting PCs to the mainframe through a gateway," CXI's Morel argues. "CXI's focus in connecting PCs to the mainframe does not stop where the LAN begins. We can offer the expertise and technology accumulated in serving the micro-to-mainframe link to the users of LANs."

LAN vendors bring another perspective and other strengths to the SNA/LAN gateway arena. They can claim greater familiarity with the intricacies of LAN functions and emphasize fast screen response, without degrading LAN functions but with faster links to the mainframe and—in some cases—fuller emulation of IBM 3270 terminal capabilities.

"If an SNA product is sold by a LAN vendor, you know it will work with the LAN," contends LAN supplier Gateway Communications Inc. president and CEO David McMaster, "If you buy it from somebody else and hope it works with the LAN, you may have a problem."

LAN vendor Proteon Inc. stresses the fast response and full-screen 3270 capability of its 3270 network interface system. Enhanced 3270 features include seven-color graphics, extended data stream and programmed symbol support. Features such as simplified configuration control, remote diagnostics and automatic multiplexer support surpass those of similar IBM products, the company says.

Replacing an IBM 3274 cluster controller, the interface system connects up to 32 3270 terminals to IBM mainframes via the company's ProNET-10 or ProNET-80 LANs. The first runs at 10M bits per second (bps); the second, 80M bps.

#### **Reach remotes at a fast clip**

For maximum response, Proteon's Channel Attach unit connects directly to the mainframe's bus and tag channel. LAN Attach units support up to 32 terminals on the LAN with control unit terminal (CUT) ports or enhanced DFT connections.

"We provide remote operation with local speed, compared to the 3274 controller," maintains John Shriver, senior product specialist. "The LAN Attach units provide 70 percent to 80 percent of IBM mainframe channel speed. It's slow to bring up 3270 screens with 9.6K-byte-per-second host links, the speed at which most remote 3270 terminals operate. On the other hand, 56K-byte-per-second connections are expensive. Our product operates two to six

## **Why system integrators**

**James J. Mullen**, The Orion Group Inc.

Enhancements to IBM Corp.'s Systems Network Architecture, LU 6.2 (Logical Unit 6.2) and PU 2.1 (Physical Unit 2.1) constitute a peer-to-peer communications protocol that permits application programs on diverse computers to directly exchange data without host-computer intervention.

A device-independent protocol, LU 6.2 enables computers under SNA to send and receive data, start and stop execution of remote applications and perform error recovery. A simple, high-level language embodies standard "verbs," such as ALLOCATE, SENDATA, RECEIVANWAIT, to control communications. PU 2.1 provides the lower level protocols necessary for peer-to-peer communications.

IBM is committed to LU 6.2 as its basic strategy for

implementing program-to-program communications in future products and has configured the standard on nearly all of its processors. Other major computer vendors have announced support for the protocol, and its recent endorsement by the International Standards Organization means that future processors on Open Systems Interconnection (OSI) networks will be able to conduct peer-to-peer conversations with processors on LU 6.2-based SNA networks.

LU 6.2 also offers system integrators a number of immediate practical advantages for software development. Applications written directly to LU 6.2 are cheaper to develop, more portable and more robust than those based on proprietary protocols for process-to-process conversations. The protocol is well-specified and complete, making major changes unnecessary. Portable implementations of LU 6.2,

times faster than a 56K-byte-per-second connection to the host."

The 3270 system does not degrade the LAN response, Shriver claims. "When we run load tests, the mainframe runs out of steam in pumping out data before the LAN does. The response is good because the deterministic access of the token ring doesn't undergo collisions or back-offs," as do CSMA/CD (carrier sense multiple access with collision detection) or CA (collision avoidance) products.

Proteon offers a similar system, the ProNET/SNA Gateway, which supports up to 32 concurrent PCs on its ProNET-4 or ProNET-10 LANs running Novell Inc. Advanced Netware/P. Each user can run two concurrent host sessions, and the gateway PC—being non-dedicated—can perform other tasks. An alternative link, the Banyan 3270 SNA option, uses a network file server to support 64 simultaneous host sessions and has dynamic network reconfiguration capability.

#### Broad support for Ethernet LANs

Bridge Communications Inc. spotlights the wide range of terminals and terminal-emulation and file-transfer programs its enhanced EtherTerm 1.2 software supports for PCs on Ethernet (IEEE 802.3) LANs. Emulation programs tested with the package mimic terminals from Digital Equipment Corp. (VT52, VT100, VT220), Tektronix Inc. (4105), Hewlett-Packard Co. (HP 2392) and Data General Corp. (Dasher 210).

The program replaces the PC's basic input/output system's interrupt 14H interface routines with its own interface and uses the Xerox Corp. XNS (Xerox Network Systems) protocol. It permits PCs to access asynchronous ports,

X.25-based public data networks and pooled modems in addition to 3270 SNA sessions.

Ethernet LANs running TCP/IP (transmission control protocol/internet protocol) are not excluded from 3270 connectivity. Based on those protocols, Bridge's TCPTerm software allows linked PCs attached to the network with a 3Com Corp. EtherLink controller board to transfer binary and text files (under the ARPANET file-transfer protocol), emulate DEC VT100 terminals and communicate with an IBM host via a CS/1-SNA communications server.

Four concurrent host sessions under the control of a DOS-compatible multitasking executive plus entry to IBM DISOSS (distributed office support system) services are provided by Ungermann-Bass Inc.'s enhanced Net/One 3270 PC package for PCs on its Net/One LAN. Emulating many 3270 and DEC VT100 terminals and 3287 printers, it controls four concurrent terminal and printer sessions and two asynchronous terminal sessions while running DOS-based applications. Support of the IBM 3270 PC Control Program Version 2.1's API allows users to run IBM Personal Services/PC for access to DISOSS services as well as Linkware Corp.'s PC Connection program.

If you want to run your PCs on a LAN running PC/MS-DOS 3.1/3.2 and IBM PC Network-compatible applications, consider 3Com's solution. The 3+3270 package installed in a network server PC on the 3+ network emulates the 3274 cluster controller, 3278 and 3279 (color) terminals and the mainframe model 3287 model 2 printer. It allows local and remote mainframe access for file transfers and transaction processing.

Many companies still rely on the 3770 batch-

---

**LAN vendors claim greater familiarity with the intricacies of LAN functions in promoting gateway products.**

---

## can't afford to ignore LU 6.2

such as The Orion Group's sna 62 peer-communications facility, can be bought off-the-shelf to speed the development of LU 6.2-based programs.

In addition, LU 6.2-based applications will migrate readily across the entire range of IBM processors from PCs to mainframes, and porting them to non-IBM processors will not entail significant restructuring of the standard interface.

In contrast to communications based on LU 2, such as conventional 3270 emulation sessions using 1,920-character screens, LU 6.2 sessions can contain characters of almost any length and in any format. With no required record size and no device-specific document-formatting code, network overhead is considerably reduced.

Finally, LU 6.2 supports communications over a

wide variety of media—including leased and dial-up phone lines, Token-Ring Network and Ethernet local area networks and X.25 links—without inherent restrictions on the data-transmission rate.

Because LU 6.2 allows network managers to choose the most economical transport medium for each segment of a network, the managers can achieve significant network cost reductions without degrading performance.

---

**James J. Mullen** is vice president of sales and marketing at The Orion Group Inc., Berkeley, Calif., which develops OEM SNA software.

---

transfer protocol instead of SNA/SDLC-3270 links, especially for high-speed remote transfer of data after business hours. The G/SNAnet package from Gateway Communications supports interactive batch transfer from IBM mainframes with remote job entry (RJE) workstations connected to the company's Novell Netware-based G/NET PLUS LAN. The product also stands out in supporting multiple LAN gateways independently of file servers and multidrop lines.

"Having one product with both 3270 and 3770 capabilities is an advantage," maintains Gateway's McMaster. "SNA users might use batch processing 10 percent of the time. But when they use it, they use it a lot, particularly at night to save on-line charges."

Custom command scripts, pop-up menus and API ease file transfers; the non-dedicated PC server uses an Intel Corp. 80186-based communications card. Each PC on the net can access up to four 3270 or 3770 sessions. The company plans to make the G/SNAnet software capable of running on any Netware-based LAN or on the IBM Token-Ring, McMaster says.

Customized remote micro-to-mainframe applications are promised by Integrated Network Systems Inc. using its SDLC Gateway PC Adapter's API. With the board and software

installed in gateway PCs, system integrators can implement automatic log-on, transaction routing and store-and-forward functions for other PCs on a NETBIOS-compatible LAN.

If you don't want to bother with plug-in boards and software for your micro-to-mainframe links, Telex Computer Products Inc. offers 1260 and 1280 Intelligent Workstations with integrated 3278/9 (coaxial) and 3276 (remote) support and mainframe file-transfer options. They can function as communications servers, diskless workstations or zero-wait-state 80286-based PC/XT or PC/AT computers on a LAN.

**Run high-end graphics**

Many users demand high-end EGA (enhanced graphics adapter)-type graphics on LAN and mainframe-linked PCs, and products from Grafpoint and Ungermann-Bass fill this need.

Supporting IBM's EGA and AT&T Co. and IBM CGAs (color graphics adapters), Ungermann Bass' Net/One 3270 PC Graphics package allows PCs linked to the company's Net/One LAN to run four concurrent 3270 graphic sessions with software such as the IBM GDDM, SAS Institute's SAS/Graph and Integrated Software Systems Corp.'s Tel-A-Graf.

**Access to mainframe DISOSS**

services and peer-to-peer communications is afforded by Orion's DIA Facility and sna 62 software for applications running on UNIX processors and LU 6.2-compatible packages on IBM PCs.

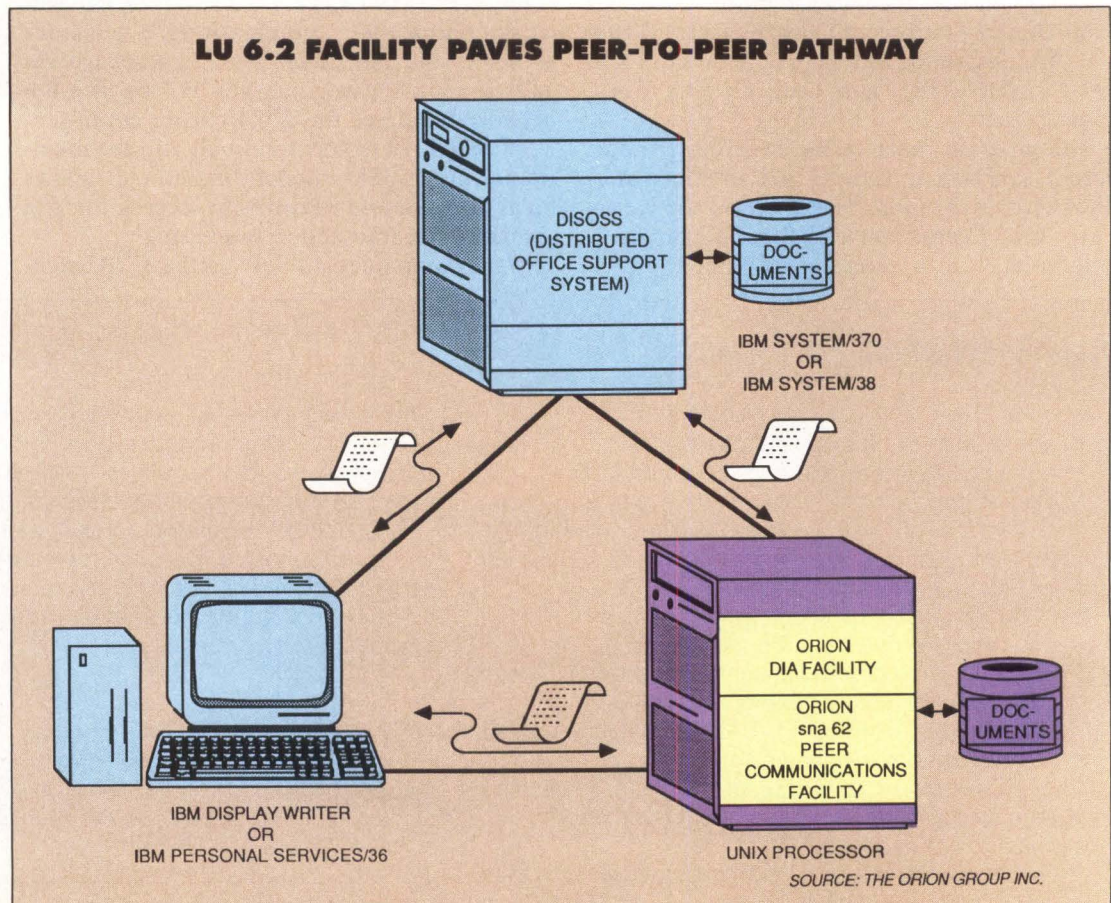

# Let Your CPU Reach Its Full Potential

## With Data Access and Retrieval At Electronic Speeds

For disk intensive applications you need a peripheral storage device that performs as quick as your CPU. That's why we designed the MegaRam *solid-state* disk. It can access stored data thousands of times faster than a rotating disk. With this dramatic speed, your computer is kept working...not waiting. In fact, it can provide a typical increase of 50% in CPU throughput! And, the MegaRam is completely transparent to your software and hardware; your CPU will treat it as another disk drive.

## When to Buy a MegaRam Solid-State Disk

1. When you need to have more users simultaneously accessing a data base without degrading response time.
2. When you need to monitor more status inputs with process control computers while working in real time.
3. When your telecommunications computers need to handle more lines and more traffic.
4. When you need your sort routines to run faster and compile programs to take less time.
5. When you need a peripheral storage device for hostile environments.

Or, for any other disk intensive application, including Data Base Management, Graphics, Process Control, or for real time processing situations such as Image Processing and Data Acquisition.

## With Reliability and Reduced Maintenance

The solid-state MegaRam, with no moving parts, provides the performance and reliability of main memory while maintaining the

storage capacity and convenience of a peripheral. It requires no adjustments and virtually no maintenance. So, your CPU not only runs faster but uninterrupted as well.

## Your CPU Can Deliver Its Full Promise of Performance

If your CPU requires faster data access and retrieval, operates in hostile environments, or demands maximum disk reliability, you'll find the MegaRam a smart, cost-effective investment. Call or write today for full details.

## The MegaRam Solid-State Disk

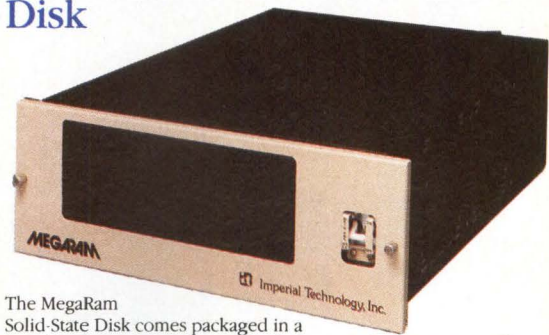

The MegaRam Solid-State Disk comes packaged in a 7-inch high, 19-inch rack mounted chassis with its own controller, power supply and blower assemblies.

Available from 2 to 512 Megabyte capacities for the following computers:

DEC • Hewlett Packard • Gould • Prime • Data General • C.D.C. • Westinghouse • Sperry Univac • Many Others.

### Features

Full Software and hardware compatibility • Error detection and correction • Field expandable • Zero latency time • No moving parts.

### Options

Battery Back-Up • Megastream tape back-up • Custom designed interfaces • Dual port capability.



## Imperial Technology, Inc.

831 S. Douglas Street  
El Segundo, California 90245  
Telephone: (213) 536-0018  
Telex: 664469 • FAX: (213) 536-0124

CIRCLE NO. 47 ON INQUIRY CARD

# Think of it as stereo printing.

What stereo did for left and right, IMAGEN has done for front and back. Because we've designed a laser printing system that truly gives you both sides of the story.

A sophisticated process allows our 7320 ImageServer XP laser printer to print on both sides of a page, without any help from you, no matter how long your documents are. And because it can support signature printing on demand, you'll have all the capabilities of the corner print shop available in the corner of your office. Which means the 7320 will not only save you time, it'll save you money.

The 7320 prints 20 original pages per minute. With high-quality graphics as well as different timesteps and sizes. It can even use 11 x 17-inch paper for engineering schematics, newsletters, data sheets, etc. And the 7320 offers full Ethernet compatibility, a unique IMAGEN advantage.

At IMAGEN, we offer a wide range of laser printing systems, including our new 3320, that can be upgraded easily to the 7320's capabilities when you need them. So if you're looking for a workgroup printing system that can handle the workload, give us a call.

800-556-1234, Ext. 199

In California, 1-800-441-2345, Ext. 199

 **IMAGEN**  
INTELLIGENT PRINTING

CIRCLE NO. 48 ON INQUIRY CARD



\*Speakers not included.

Screen-capture and print utilities are available with the package.

For demanding applications, Grafpoint's TNET-05 software allows PCs on a LAN to emulate Tektronix 4105 and 4107 color graphics terminals with a device driver processing the terminals' commands under MS-DOS. The 4105 version takes up only about 100K of RAM, and both versions allow users to hot key between graphics and DOS sessions.

Grafpoint's future plans include a version of TNET, emulating the high-end Tektronix 4115, and a coax version linking to SNA networks via a gateway. The company also will offer a package allowing a PC/AT equipped with Tektronix's new SGS 430 stereo color graphics system to emulate a Tektronix 4107 terminal, says Grafpoint CEO Charles Lingel.

### Move up to DEC-IBM links

Effectively linking IBM and DEC VAX computer systems with LANs might require more sophisticated, flexible and higher level software-based solutions. Xyplex Inc., for example, offers the distributed Network Processing System, based on a host interface unit, PC controllers, remote gateways and distributed-network processors.

With system software residing in the DEC VMS operating system, it can, the company claims, link IBM and DEC computers and terminals to almost any LAN or wide-area network, including those based on Ethernet, thin-wire Ethernet, CATV broadband or optical fiber.

PC XPANDER hardware and software allows VAXes and PCs to control and execute each other's applications. VAXmail can be run from MS-DOS or data on the VAX can be downloaded into Lotus Development Corp.'s 1-2-3 on a PC, and execution of the program can be initiated from the VAX.

Interlink Computer Sciences Inc. emphasizes similar two-way communications between DEC and IBM environments for its 3711 Gateway in virtual machine (VM) or multiple virtual storage (MVS) versions. They have the additional advantages of direct application-to-application communications, transparent data transfer and full-screen emulation of a DEC VT100 or VT220 terminal on an IBM PC or 3278 terminal.

"You can use the standard IBM file-access procedure to access a DEC file and use standard DEC procedures to access an IBM file," asserts Interlink president Lambert Onuma. "You write the same code to access a DEC file via DECnet as you would to access a VTAM file on the IBM mainframe. With full-screen DEC terminal emulation on an IBM 3278 terminal, as opposed to the line-by-line capability of

some products, you can emulate DEC applications like All-In-1, the Editor and videotex."

Onuma claims his product's bilateral full-screen capability, file access to the record level, program-to-program communications and 500K-byte-per-second throughput give it advantages over DEC's SNA Gateway. "With our product, a guy at a terminal has good response time. Going at 56K bytes per second [to a host computer] for terminal emulation is too slow."

### LU 6.2 lacks implementations

IBM's LU (logical unit) 6.2 and advanced program-to-program communications (APPC) protocols, plus associated lower level transport mechanisms, will play an increasingly important role in micro-to-mini-to-mainframe and LAN-to-SNA communications (see "Why system integrators can't afford to ignore LU 6.2"). But right now, LU 6.2 is mainly talk and little action.

LU 6.2's current status is defined by four key words: applications, demand, standards and IBM. Without applications, LU 6.2 remains just a potentially powerful protocol. But demand is necessary to spur applications, and most industry observers see little demand.

"There are a lot of our customers talking about LU 6.2, but none saying they would buy LU 6.2 capability if we had it," says Gateway Communication's McMaster. "We have developed LU 6.2 capability on our 80186-based communications-controller card. But we haven't found any applications to warrant putting it on our networks."

Onuma agrees: "I haven't seen many users doing program-to-program communications. The applications aren't set up that way." He contends that confusion among users and system integrators about the great diversity of micro-to-mainframe products—LU 6.2 in particular—is impeding acceptance.

Part of the confusion about the protocol concerns lower level links and much of the rest, some experts assert, stems from IBM. Some products billed as providing LU 6.2 capabilities support only the older physical unit (PU) 2.0 functions and not PU 2.1, which is necessary to fully implement program-to-program communications as well as multiple sessions and multiple links between devices.

IBM's announced support for the enhanced connectivity facility (ECF) architecture, and the latest incarnation of LU 6.2—distributed data management (DDM) architecture linking PCs, System 3/Xs and CICS on 370 mainframes—only serves to muddy the waters further, many observers insist.

In any case, many of the functions promised (and not yet delivered) by ECF, such as creation of mainframe virtual disks, PC access to main-

---

**Effectively linking IBM and DEC VAX computers requires sophisticated, flexible and higher level software-based solutions.**

---

## Companies mentioned in this article

**AST Research Inc.**  
2121 Alton Ave.  
Irvine, Calif. 92714  
(714) 863-1333  
Circle 383

**Bridge Communications Inc.**  
2081 Stierlin Road  
Mountain View, Calif. 94043  
(415) 969-4400  
Circle 384

**CXI Inc.**  
3606 W. Bayshore Road  
Palo Alto, Calif. 94303  
(415) 424-0700  
Circle 385

**Digital Communications Associates Inc.**  
1000 Alderman Drive  
Alpharetta, Ga. 30201  
(404) 442-4000  
Circle 386

**Gateway Communications Inc.**  
2941 Alton Ave.  
Irvine, Calif. 92714  
(714) 553-1555  
Circle 387

**Grafpoint**  
4340 Stevens Creek Blvd.  
San Jose, Calif. 95129  
(408) 249-7951  
Circle 388

**Integrated Network Systems Inc.**  
Box 91395  
Mobile, Ala. 36691  
(800) SNA-3270  
Circle 389

**Interlink Computer Sciences Inc.**  
39055 Hastings St.  
Fremont, Calif. 94538  
(415) 792-6212  
Circle 390

**Network Software Associates Inc.**  
22982 Mill Creek  
Laguna Hills, Calif. 92653  
(714) 768-4013  
Circle 391

**Novell Inc.**  
748 N. 1340 W.  
Orem, Utah 84057  
(910) 971-4001  
Circle 392

**The Orion Group Inc.**  
1912 Bonita Way  
Berkeley, Calif. 94704  
(415) 548-0947  
Circle 393

**Proteon Inc.**  
2 Technology Drive  
Westborough, Mass. 01881  
(617) 898-2800  
Circle 394

**Telex Computer Products Inc.**  
6422 E. 41st St.  
Tulsa, Okla. 74135  
(918) 627-1111  
Circle 395

**3Com Corp.**  
3165 Kifer Road  
Santa Clara, Calif. 95052  
(408) 562-6400  
Circle 396

**Ungermann-Bass Inc.**  
3900 Freedom Circle  
Santa Clara, Calif. 95052  
(408) 496-0111  
Circle 397

**Xyplex Inc.**  
100 Domino Drive  
Concord, Mass. 01742  
(617) 371-1400  
Circle 398

frame databases and automatic downloading and conversion into popular PC file formats such as DIF (document interchange format) and worksheet, have been offered for years by micro-to-mainframe software.

"I think everybody is waiting on IBM. It will set the tone on how popular LU 6.2 is going to be," maintains Gateway's McMaster. "But there are some loose ends in the strategy. They haven't got it all together yet."

### Software integrates LU 6.2

System integrators don't have to wait for IBM, however, to integrate LU 6.2 functionality into their applications. They can use The Orion Group Inc.'s DIA (document interchange architecture) Facility or Network Software Associates Inc.'s (NSA) AdaptSNA LU 6.2/APPC.

An enhancement to the company's sna 62 Peer Communications Facility, DIA Facility contains a set of C language function calls. They allow an application to access IBM mainframe DISOSS/370 library and distribution services. A PC running an IBM package with LU 6.2 capability, such as Personal Services/36, can have similar access and exchange data.

NSA's AdaptSNA package implements both basic and higher level mapped LU 6.2 verbs. The companion AdaptSNA LU 6.2/ASSIST tool kit eases program development with an application shell, interactive learning/simulation facilities and high-level language interfaces to C and BASIC.

Orion president Paul Rampel spells out the advantages of LU 6.2-based programs for PCs on a LAN linked to a host computer. "LU 6.2 offloads host processing, such as formatting, to the PC. And throughput is increased because

less data has to go back and forth between the PC and host."

For the future, expect LU 6.2 functionality on a chip for advanced workstations, SNA-OSI (Open Systems Interconnection) links using the protocol and an increasing number of LU 6.2-based 3270 and 3770 emulator products. For example, Orion is developing the latter two types of products via development agreements with, respectively, Retix and Xicom Technologies Corp.

The SNA-OSI gateway will permit transparent messaging between OSI-based X.400 store-and-forward services and SNA-based messaging under SNADS (SNA distribution services) and DISOSS through address translation and message formatting. Rampel says the LU 6.2-3270 and -3770 product will ease the transition to LU 6.2 by providing simultaneous LU 6.2 and conventional 3270 emulator functions via support of lower logical units (0, 1, 2, 3) and physical units (2).

Rampel expects long-awaited LU 6.2-based applications from major personal computer software vendors—as well as distributed databases grounded on the protocol—by the end of 1988 or early 1989. CXI's Morel foresees LU 6.2 products much sooner from micro-to-mainframe link vendors—beginning in the second half of this year.

Ultimately, what the protocol represents to both micro-to-mainframe and LU 6.2 product vendors is almost as important as the capabilities it promises: A welcome step toward standardization in a chaotic and confusing market. □

Interest Quotient (Circle One)  
High 486 Medium 487 Low 488



# Everything you've ever wanted in an IBM PC/AT compatible board computer. And less.

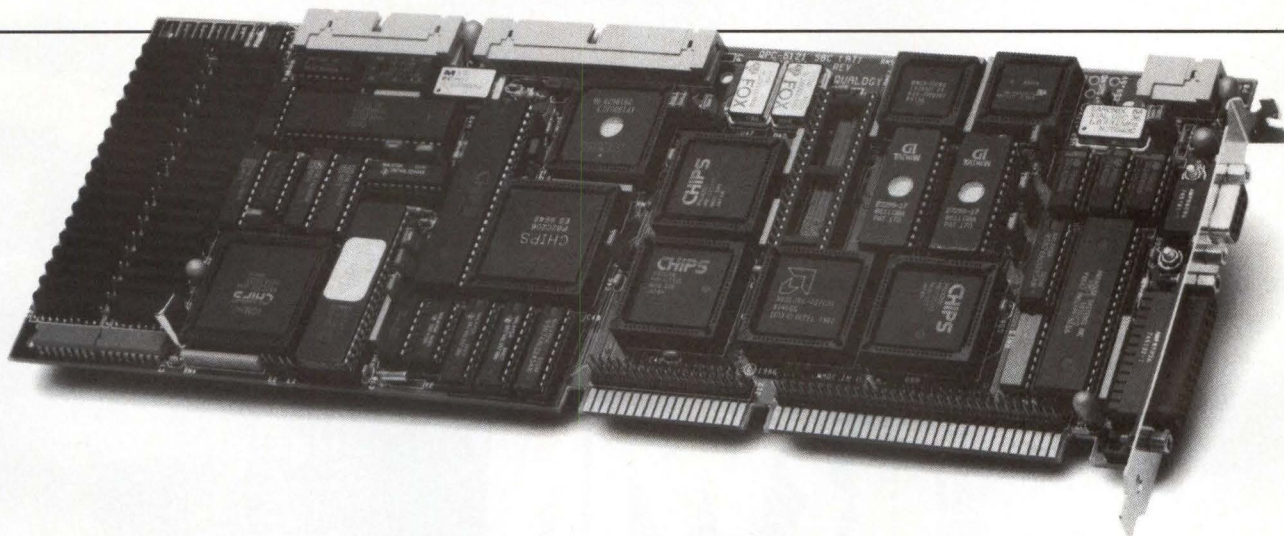

The Qualogy 5121™ does on one board what other PC/AT compatibles do on three—using a third less power.

**And more.** The 5121 is the most highly-integrated IBM PC/AT™ compatible single board computer in the industry. On a single board, it delivers all the functions of the PC/AT motherboard—*plus* additional memory, controllers for floppy disks, Winchester drives, I/O ports and a clock/calendar.

**And less.** It does all this using only 30% of the power consumption required by comparable three-board systems. This is a distinct advantage where high ambient temperatures can be a major factor in equipment reliability.

**Even less is even more.** When the QPC-5121 is combined with our EGA graphics daughter board, the two boards can replace *four boards*—yet take up only *one* slot in a passive AT-compatible backplane! No other product family on the market can even begin to match this extraordinary level of integration.

**Software compatibility.** Not surprisingly, the QPC-5121 is completely software-compatible with the IBM PC/AT because of the BIOS from Phoenix™ Technologies.

**It all adds up to much, much more.** Take this high-level of functionality, low power consumption, compact, efficient design and utter reliability. Add total compatibility plus an enormous installed base of PC/AT software and hardware. Then add substantial cost savings.

**Wait—there's even more!** Finally, we back everything up with Qualogy's responsive support program, our nation-wide network of trained engineers guarantees a fast repair turn-around.

**Could you ask for anything more?** If you want to know more about the QPC-5121 in particular, or more about Qualogy in general, we'd like to hear from you. Please call:

**800-556-1234, ext. 86.**

In California: **800-441-2345, ext. 86.**

Or write to the address below:



2241 Lundy Avenue, San Jose, CA 95131.  
Telex 4993489

Qualogy, QPC-5121 are trademarks of Qualogy Inc. IBM and PC/AT are trademarks of International Business Machines Corp. Phoenix is a trademark of Phoenix Technologies, Inc.

# Nobody in saves more PC hard



**IRWIN**<sup>®</sup>  
MAGNETICS

**THE NUMBER 1 NAME  
IN PC DATA RESCUE**

# the world disk data than Irwin.

It's a fact — with more than 300,000 systems already in use, Irwin is far and away the first choice of PC users for reliable tape backup. Irwin also is the built-in system of choice by leading computer manufacturers.

Irwin offers PC designers and systems integrators these unique advantages:

- Proven, low-cost tape backup systems with  $10^{13}$  reliability using high capacity, industry standard, rugged mini-cartridges.
- A broad product line of easy-to-integrate 10, 20 and 40 MB drives in both 5¼" and 3½" form factors.
- Manufacturing facilities delivering over 20,000 units a month with additional capacities on standby.
- Patented, closed-loop servo positioner for the write/read head allows data recorded on an Irwin drive to be read by any other upward-compatible Irwin drive.
- Easy-to-use, but powerful, EzTape™ visual software for file-by-file or complete disk backup with unattended, automatic start.
- A staff of more than 50 graduate engineers, experienced and responsive in working with OEMs — and saving them money.

When you choose a tape backup system manufacturer as your partner, consider Irwin Magnetics.

Call our OEM sales department at 1-800-421-1879 and get in on the best selling tape backup system in the microcomputer industry. Or write Irwin Magnetic Systems, Inc., 2101 Commonwealth Blvd., Ann Arbor, MI 48105. We want to work with you.

EzTape is a trademark of Irwin Magnetic Systems, Inc.  
© 1987 Irwin Magnetic Systems, Inc.



**IRWIN**<sup>®</sup>  
MAGNETICS

Nobody backs up your data like Irwin.

CIRCLE NO. 50 ON INQUIRY CARD



**DATA FLEX**®

*A Breakthrough  
in  
DBMS/4GL  
Price and  
Performance  
for  
UNIX V  
and  
VAX/VMS*

**DATA FLEX**

DataFlex is a high performance applications development database system with a rich 4th generation command language and automatic code generators. DataFlex's on-line multi-user transaction processing and powerful multi-file Query give

you the information you need when you need it. Plus, applications can be transported to and from VAX, UNIX V, XENIX and PC systems without change. Pricing for UNIX V and VAX systems starts at \$1,800. Call today for complete details.

**DATA ACCESS CORPORATION**  
8525 S.W. 129th Terrace, Miami, FL 33156-6565 (305) 238-0012 Telex 469021 DATA ACCESS CI

VAX and VMS are trademarks of Digital Equipment Corporation, UNIX V is a trademark of AT&T. XENIX is a trademark of Microsoft. DataFlex is a Registered Trademark of Data Access Corporation.

CIRCLE NO. 51 ON INQUIRY CARD

# MULTIPROCESSORS BOOST SYSTEM POWER

By often outperforming uniprocessor minicomputers, multiprocessors can bolster OEMs and system integrators against traditional market giants

**Andrew Allison**, Contributing Editor

Intensified competition in conventional computers and forecasts of billions of dollars in sales are attracting more and more suppliers to the multiprocessor market. However, early participants have had mixed results in penetrating this midrange market segment, and several have gone out of business.

System integrators and OEMs should be aware that suppliers use the term multiprocessor rather loosely to describe a broad range of system architectures. The scheduler-driven execution of many tasks on a single processor, for example, is often (incorrectly) identified as multiprocessing, rather than multitasking.

Multiprocessor systems are optimized for multiple job throughput. Parallel processors, in contrast, focus on the execution of single jobs. Both, however, employ a number of processors, and the prospective buyer should be more concerned with performance and cost than with

what often amounts to architectural semantics.

Multiprocessors are defined here as systems that support a minimum of four processors. Although the same hardware and software implementation strategies apply to both 16- and 32-bit systems, bus bandwidth and address range requirements make 32-bit systems much more attractive for multiprocessor designs.

## What are the common threads?

Available from numerous suppliers, multiprocessor systems make use of merchant market microprocessors (predominantly the Motorola Inc. MC68020) and established superminicomputer architectures. Most systems are tightly coupled; in other words, the processors share common memory and a single copy of the operating system. On the other hand, the processors in loosely coupled systems have individual copies of the operating system in local memory.

Operating systems for multiprocessors are typically UNIX-derived, with many suppliers offering a choice of System V or Berkeley Version 4.2 compatibility. Each vendor has its own approach to tuning the operating system for multiprocessor operation. Indeed, among systems based on merchant market microprocessors, this tuning is the chief means of differentiation.

The extent of modification required for existing applications and utility software to run in a multiprocessing environment is an important factor: in fact, buyers should view the need for anything more than recompilation with extreme caution.

Systems designed for the commercial multi-user/multitasking market are usually homoge-

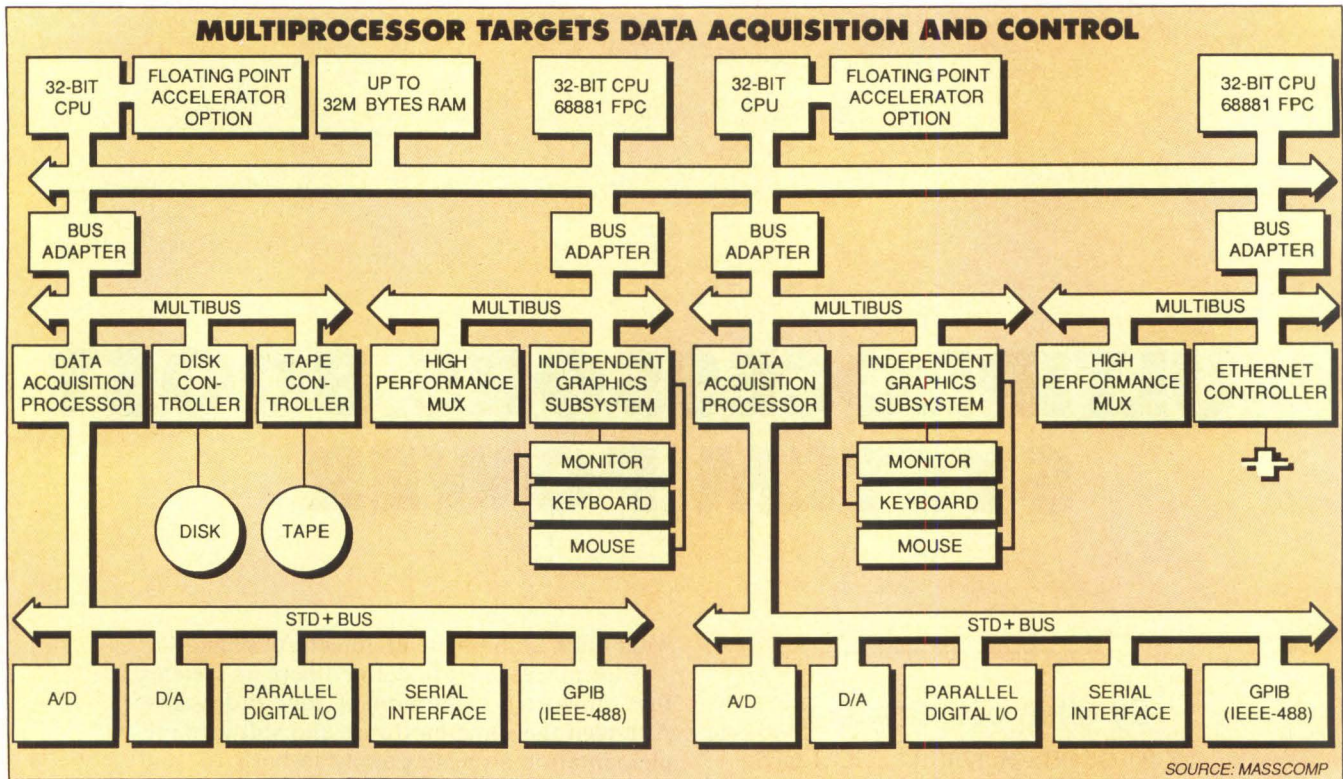

The I/O portion of the back-plane in Mas-scomp's MC5700 is subdivided into four segments, each of which can accommodate standard Multibus controllers in addition to proprietary data-acquisition sub-systems, communications and graphics controllers.

neous (i.e., they use the same processor subsystems) throughout). Many such systems employ separate I/O processors. Those intended for specific applications, of which vector processors are the best known, tend to be heterogeneous. Multiprocessor implementations with UNIX-based front ends (such as Digital Equipment Corp.'s MicroVAX or Sun Microsystems Inc.'s workstations) are beginning to replace the more familiar configurations of superminicomputers with attached processors.

Multiprocessors based on microprocessors divide into three categories: low-end multiprocessors (four to 16 processors), midrange multiprocessors—or multimicrocomputers—(16 to 64 processors) and massively parallel systems (more than 64 processors).

**What's available?**

Convergent Technologies' S/1280 is a typical low-end multiprocessor. Up to four loosely coupled, 68020-based application processor units (APUs) and multiple, application-specific, Intel Corp. 80186-based I/O processors (IOPs) support up to 128 users. All processors share an 11M-byte-per-second asynchronous system bus.

File processors (up to five per system) each support four ST506 disk drives, and data processors (two per system) interface up to six SMD (storage module device) drives and four half-inch tape drives. The APUs run under Convergent's version of UNIX System V Rel.2,

and the company's real-time operating system controls the IOPs.

Areté Systems Corp. takes a similar approach with its family of fault-tolerant systems. Its Series 1000 machines support up to four 68020-based APUs, 12 68000-based IOPs and 256 users. Unlike the Convergent implementation, however, Arété's APUs are tightly coupled, with 8K bytes of onboard cache and up to 16M bytes of shared main memory.

Database IOPs (up to four per system) have 256K bytes of onboard static RAM, and support either four disk drives and one cartridge drive or two disk drives and four half-inch tape drives. Communications IOPs (up to 11) include up to 1M byte of static RAM, eight RS232 ports and a parallel port. Three buses interconnect the subsystems; a 12M-byte-per-second processor-memory bus, a 25M-byte-per-second mass storage bus and an 8M-byte-per-second communications and control bus. Over half of the 1,000 systems delivered in the three years ending last December were remarketed by Sperry Corp. (now Unisys).

Another, better known, fault-tolerant system supplier, Stratus Computer Inc., takes a different approach. Stratus' XA-Series systems (remarketed by IBM Corp. as the System/88 and, outside the United States, by Olivetti) incorporate up to six loosely coupled processor subsystems. Each of these contain two CPU modules operating in sync.

Each CPU module contains two micro-processors, plus comparison logic that removes



NEC Astra XL/32

NEC

# OUR NEW MINICOMPUTER HAS UNIX<sup>®</sup> AND OPEN ARCHITECTURE. IT ALSO OPENS DOORS.

## Introducing the Astra XL/32.

The Astra<sup>®</sup> XL/32 is the first in a line of UNIX-based multi-user systems designed for small business and department level users. The XL/32 provides the power, flexibility and expandability once found only in larger, more expensive systems. It supports up to 16 MB of main memory, up to 1 GB of disk storage and up to 32 users. Which means it can efficiently and economically keep pace with the growth of any small business or department. And give VARs the necessary flexibility to stay ahead of your customers' fast-moving needs. It also protects your biggest asset—your software investment.

NEC designed the XL/32 to take advantage of present as well as emerging industry standards. UNIX System V, for instance, is fast becoming a standard for scientific, educational, commercial and office automation applications. The XL/32 also supports a wide range of IBM and

other communications protocols and advanced networking capabilities. Which means a high-level of compatibility with other vendors' systems.

### **When you team up with NEC, we don't end up playing against you.**

Unlike most other big computer companies, our sales force is not out trying to sell your prospects. They're out there to help you make the sale. NEC offers larger discounts than the competition which means higher margins for you. Discounts are applied across all product families. And we have an aggressive co-op plan and training for your sales force. We even have a teaming program to assist you in establishing co-marketing agreements in geographic markets you don't cover.

### **NEC opens the way to one of the biggest and hottest product lines you can sell.**

NEC offers additional comprehensive product

families that include a line of Advanced Personal Computers, communications equipment and reliable Spinwriter<sup>®</sup> and Pinwriter<sup>®</sup> printers. Plus you have the power of NEC behind you. NEC is a \$13 billion leader in computers and communications.

Want more? For our Astra XL VAR information kit call 1-800-343-4419. In Massachusetts call (617) 264-8635. Or write to NEC Information Systems, Inc., Dept. 1610, 1414 Massachusetts Ave., Boxborough, MA 01719.

# NEC

NEC Information Systems, Inc.

UNIX is a trademark of AT&T Bell Laboratories.

CIRCLE NO. 74 ON INQUIRY CARD

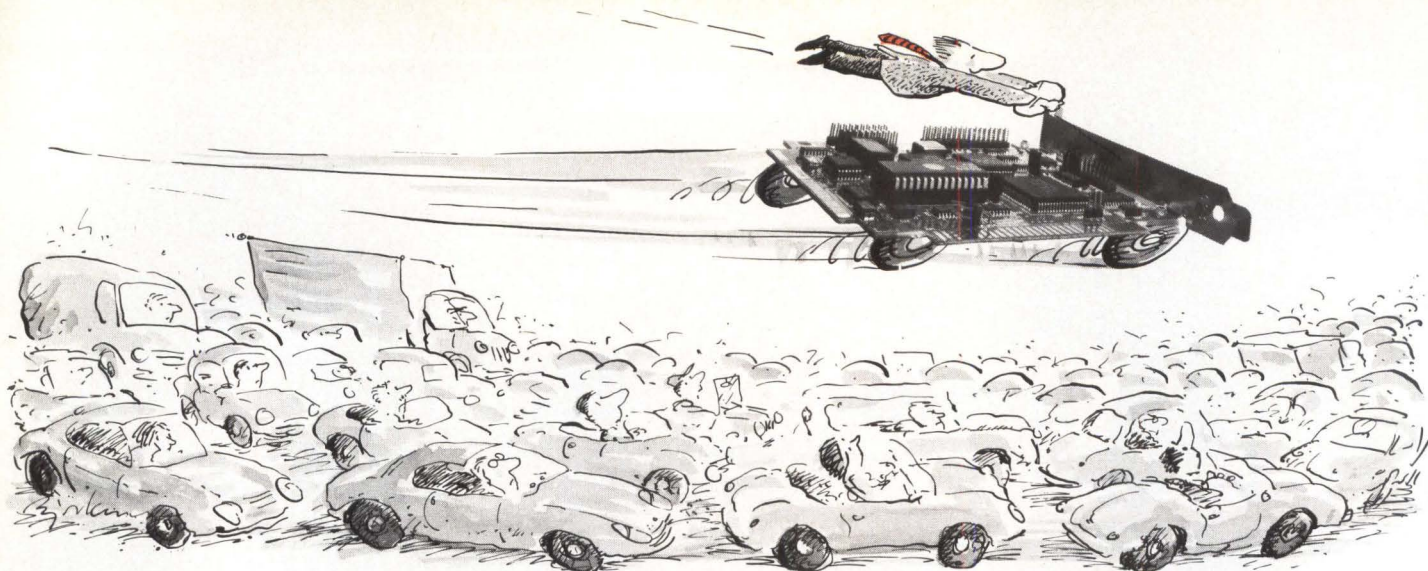

# Life in the fast lane.

Rise above your competition with our new family of high performance disk and tape controllers.

If you're designing an engineering workstation, a CAD/CAM system or a high-end micro, we've got your disk and tape controllers.

Western Digital has moved into the fast lane, too, leveraging our proven experience in controller technology to bring you board-level solutions that interface both ESDI and ST412/506 drives to 32-bit systems.

And we've combined expertise and manufacturing capabilities with Adaptive Data's advanced LSI to provide you with solutions for peripherals clocked at up to 24 MHz.

#### THINK FAST. THINK WESTERN DIGITAL.

For your new 386-based systems, our new WD1005-WAH is the answer. It's an AT-bus compatible controller for ESDI drives that's full-featured, with extensive ECC and data recovery techniques built in.

To interface ST412/506 drives to AT compatible systems zooming along at up to 16 MHz, specify our new WD1006-WAH. It uses either MFM or RLL encoding, supports 1:1 interleaving, and includes full track buffer with read-ahead caching.

**WE MAKE SCSI HUM, TOO.**  
If your design spec calls for

using a SCSI interface, we've got board-level answers for you.

We've combined our WD33C93 single-chip SCSI bus controller with the ADS-3570 buffer manager chip and ADS-1000 disk controller to bring you the D200S family of ESDI-to-SCSI hard disk controllers.

The D200S family interfaces up to four ESDI drives, to give your system the potential for over a gigabyte of storage. And they're available in six performance versions, for systems running synchronously up to the maximum performance permitted by the ANSI standard, 4 MB/s.

And the new T100A from Western Digital interfaces QIC-36 and QIC-120 tape drives to SCSI hosts. Plus, we have XT and AT host adapters for all our SCSI disk and tape controller products.

#### MOVE INTO OUR LANE.

Put yourself on the road to higher performance and lower cost with Western Digital. For information on any of our controllers, call 800-847-6181

or write Western Digital Corporation, Attn: Literature, 2445 McCabe Way, Irvine, CA 92714.

IBM XT and IBM AT are trademarks of International Business Machines Corporation.



**16 KB Track Buffer  
w/Read Ahead Caching  
for PC/AT bus.**

**4 MB/s Full Spec  
SCSI Performance**

**WESTERN DIGITAL**

CIRCLE NO. 53 ON INQUIRY CARD



the module from service and initiates diagnostics in the event of a disparity. Communications and disk controllers, memory and the links between them are also duplexed. Stratus replaced its original, 68010-based product line with 68020-based products in February.

Masscomp targets its multiprocessors at a specific market segment: high-performance, real-time data acquisition and technical computation. The company shipped its first system in November 1982 and its 2,000th over a year ago. The focus on real-time applications, and a timely switch from the original 68010-based product to using 68020s, has kept the company growing in a flat environment.

Masscomp's top-of-the-line MC5700 accommodates up to four processors. The tightly coupled APUs incorporate 8K-byte caches and a 1K-byte TLB (translation lookaside buffer), a proprietary memory-management unit (MMU) and three RS232 ports. A 68881 floating-point coprocessor is standard, but it can be replaced with a standalone floating-point accelerator that triples performance to 3 million Whetstones per processor.

The MC5700 APUs, one I/O bus adapter per APU and up to 32M bytes of shared memory are connected by a 30-slot, 26.67M-byte-per-second, segmented system bus. Each I/O adapter provides a direct-memory access (DMA) Multibus interface. Also available, in addition to the range of conventional I/O controllers, are proprietary subsystems for data acquisition and graphics, and eight-port RS232 multiplexers (eight per system).

Each system's pair of bit-slice, microprocessor-based, data acquisition and control processors interfaces to two nine-slot STD buses with a combined throughput of 2M bytes per second. Masscomp also offers a range of propri-

etary analog and digital controllers that enable an aggregate processing rate of 1 million 12-bit samples per second. The operating system supports both UNIX System V and Berkeley UNIX Version 4.2 and is enhanced for real-time operation.

NCR Corp. also has an entry in the microprocessor-based multiprocessor market. The NCR 9800 uses one to eight loosely coupled NCR/32-based APUs, each with up to 16M bytes of local memory. These are linked to one to four shared data storage processors (DSPs) by dual, 3M-byte-per-second channels. The DSPs incorporate from 2M to 16M bytes of battery-backed-up local memory, of which 1M byte is required for system-management software (load balancing, mirroring, error recovery, etc.). Individual APUs handle I/O operations. NCR introduced a 68020-based version of its Tower line in February (MMS, March, Page 33). The Tower 32/800 supports up to four processors in a Multibus II-based system.

#### Multimicros vie with superminis

Midrange multiprocessors, sometimes called multimicrocomputers (MMS, December 1986, Page 49) achieve superminicomputer and even minisupercomputer performance by combining 16 to 64 processors with memory and I/O subsystems, usually in tightly coupled configurations. Like low-end multiprocessors, they use proprietary system buses, standard microprocessor I/O buses and variations on the UNIX theme.

The best known supplier, Sequent Computer Systems Inc., has installed over 150 of its National Semiconductor Corp. NS32016- and NS32032-based Balance 8000 (two to 12 processors) and Balance 21000 (two to 30 processors) systems since initial deliveries in Decem-

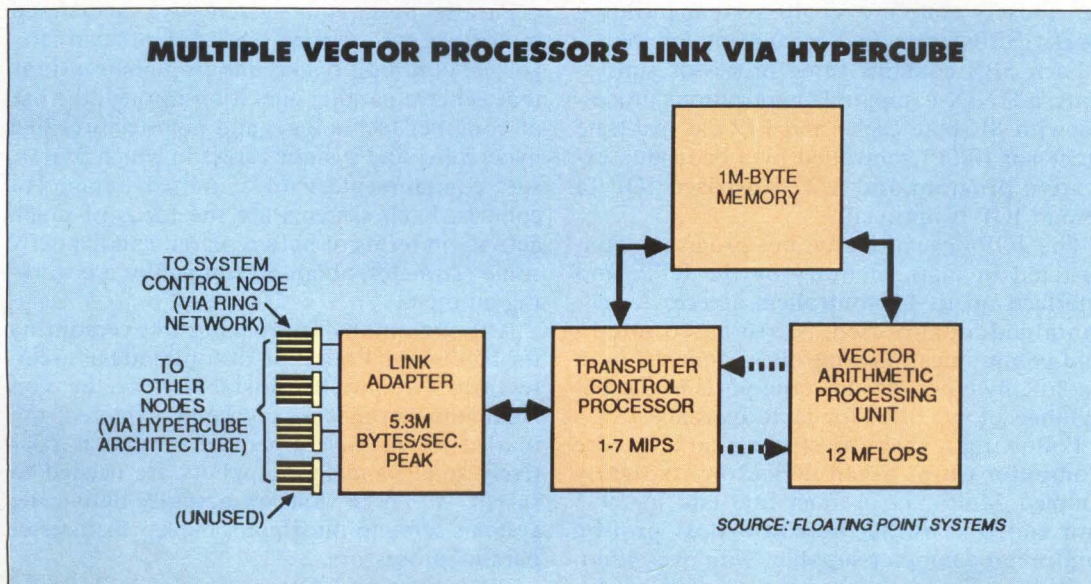

Each processing node in a T Series system, from Floating Point Systems, includes a high-performance vector processor connected to other processors in a hypercube configuration, and to a system control node via a ring network.

### SELECTED LINPACK (FORTRAN) BENCHMARK RESULTS

| Computer                   | Linpack MFLOPS |          |
|----------------------------|----------------|----------|
|                            | (64-bit)       | (32-bit) |
| DEC VAX 8800 (2)           | 2.0            | 2.7      |
| Sequent Balance 21000 (30) | 1.5            | 2.25     |
| DEC VAX 8550/8700/8800     | .99            | 1.35     |
| Encore Multimax 120 (16)   | .5             | NA       |
| DEC MicroVAX II            | .13            | .17      |
| Masscomp 5700              | .099           | NA       |
| Sequent Balance 8000       | .059           | .075     |
| Encore Multimax 120        | .055           | .067     |

**Note:** Argonne National Laboratories reports results for single processors. Multiprocessor results, with number of processors in parentheses, are from vendors.

Source: Argonne National Laboratories, Mathematics and Computer Science Division, Technical Memorandum 23, Dec. 8, 1986, unless otherwise indicated.

ber 1984. At press time, announcement of support for another microprocessor was scheduled for this month.

The Balance architecture uses dual-processor modules, each processor having its own floating-point unit (FPU) coprocessor, MMU and 8K bytes of two-way, set-associative cache.

Subsystems are connected by a 26.67M-byte-per-second system bus and a serial link that handles interrupts, semaphores and error management. NS32016-based IOPs (up to four per system) provide SCSI (small computer systems interface) bus and Ethernet interfaces plus two serial ports. Each subsystem supports up to four Multibus couplers. As with all multimicrocomputers, the number of backplane slots (12 for the 8000, 26 for the 21000) is the limiting factor for expansibility.

Tolerant Systems Inc.'s Eternity line is the next most popular of this genre, with 60 installations by the end of last year. As implied by the name, this fault-tolerant implementation can loosely couple over 40 system building blocks (SBBs) via a dual-coaxial interconnect.

Each SBB contains three processor subsystems; a UNIX-compatible applications processor with 8K-byte cache and FPU, a real-time processor (RTP) controlled by a dedicated executive program and a 32016-based IOP (a second IOP is optional).

The IOPs execute channel programs constructed in main memory by the RTP, and interface up to 15 controllers apiece. A self-contained, dual-ported, 32016-based intelligent communication controller connects up to six 56K-byte-per-second serial ports to the I/O channels of two SBBs for fault tolerance.

Following a shaky first two years, Encore Computer Corp. began delivering its tightly coupled Multimax product line late in 1985 and ended 1986 as the third most prolific multimicrocomputer supplier, with over 40 installations. Encore's products employ an ap-

proach similar to that of Sequent—two microprocessors per processor card. Encore's system bus—called "Nanobus"—uses separate 32-bit address and 64-bit data paths; and two-, four- and 8-way memory interleaving to provide a 100M-byte-per-second peak throughput.

With the optional Weitek Inc. 1164/1165-based floating-point accelerator, and a standard 64K-byte cache, the Multimax 320 subsystems (up to 20 per system) claim a performance of 2 million Whetstones.

Encore offers two kinds of IOPs: one that incorporates SCSI-bus and Ethernet controllers and one that interfaces three SCSI buses. Each SCSI bus supports four eight-channel disk controllers and a four-channel tape controller. All other I/O takes place via Ethernet connections to 32016-based I/O servers, each with 16 RS232 ports and a parallel printer port. The January announcement of an upgrade to the 32332 implies that Encore stands committed to the 32000 product family.

The fourth member of the original 32000-based multimicrocomputer system suppliers, with 25 systems installed at the end of 1986, is Flexible Computer Corp. The April 1986 announcement of a 68020-based processor module made Flexible the first supplier to offer a truly heterogeneous multimicrocomputer. The FLEX/32 implements a loosely coupled, hierarchical system architecture with three separate buses: local buses that accommodate two processors and/or memory modules, dual synchronous common buses that connect 10 local buses per chassis and an RS422 SelfTest bus that connects all modules in a given chassis. A VMEbus interface on each local bus module (processor or memory) handles all I/O.

#### Parallel processors stretch the limit

Parallel processing systems are specialized multiprocessor systems. They fall into two categories: common backplane implementations that achieve parallel operation through the use of compiler technology, and architectures like hypercubes and systolic arrays in which processors communicate with a limited number of cohorts. Such systems are the focus of much activity in terms of both research and hype. By some estimates, about 60 companies are working on them.

Although many approaches to overcoming the bandwidth limitation of common bus architectures (frequently mislabeled as the von Neumann bottleneck) are being explored, the market for massively parallel systems is relatively small, and few suppliers are needed to satisfy it. Three that are actually delivering systems serve to illustrate some key features of parallel processors.

BBN Advanced Computers Inc.'s Butterfly

**Suppliers use the term multiprocessor rather loosely to describe a broad range of system architectures.**

## The Staggering Complexities of **CIM** Become Surprisingly Simple...

### The AMS Conference/ Exposition Can Help You Conquer the Computer Integrated Mystery

CIM. It's here today—as the major philosophy guiding modern manufacturers.

Fortunately, there's AMS, too. It's the premier computer integrated manufacturing event of the year. And, for anyone with a major stake in getting their company's product into the marketplace—from Senior Managers and CEOs, to Plant Superintendents, MIS/DP Managers, and the Marketing Team—AMS is the answer to comprehending the intricacies of CIM. Here is why:

**The Exhibition:** With 200 exhibitors—the world's leading suppliers of CIM products and services—you'll see state of the market innovations, make on-the-spot comparisons and discover the right path to reaching your company's goals.

**The Conference:** With 60 timely sessions—focused on how to get CIM up and functioning in your facility—you'll absorb the knowledge you need to make important CIM decisions with confidence.

Sessions cover strategic planning for CIM, integration of CIM sub-systems, and CIM functions (design, information management, material handling, production).

### IMPACT Shows You CIM... The Way CIM Ought To Be!

## IMPACT '87

The all new IMPACT (Integrated Material Handling Production And Control Technology) is a 24,000 square foot display at the center of the AMS Exhibition.

It's a fully integrated mini factory produced by the Systems Integrator—Arthur Andersen & Co.

# ARTHUR ANDERSEN & CO.

IMPACT demonstrates how the material handling equipment, robots,

machine tools, PLCs, computers, CAD/CAM and manufacturing systems of 14 major manufacturers functioning together in an efficient CIM System. It's proof that CIM is workable and achievable today.

Co-Participants include:

*Allen Bradley*  
*Alliance Automation*  
*Arthur Andersen & Co.*  
*Cherry Electrical Products*  
*Computer Methods Corporation*  
*Denniston & Denniston*  
*INTEL*  
*Interactive Images*  
*Intergraph*  
*IBM*  
*Pritsker & Associates*  
*Rexnord*  
*Tandem Computers*  
*Wes-Tech*

## ...At AMS '87

You'll take a giant step toward understanding CIM by mailing this coupon for complete AMS Conference/Exposition registration information. Respond now and receive a ticket for **FREE** admission to the AMS Exposition (A \$25 VALUE!). Or, call (312) 299-9311 and ask for AMS registration.

\_\_\_\_\_ Yes. Send me the registration information described above.

\_\_\_\_\_ My company is interested in exhibiting at AMS.  
Please have your representative contact me.

Name \_\_\_\_\_

Title \_\_\_\_\_

Company \_\_\_\_\_

Address \_\_\_\_\_

City/State/Zip \_\_\_\_\_

Telephone (\_\_\_\_) \_\_\_\_\_

Mail to: **CEG** Cahners Exposition Group, 1350 East Touhy Ave.,  
P.O. Box 5060, Des Plaines, IL 60017-5060.

Attn: AMS Registration

©1987 Reed Holdings, Inc.



A Member of:



©1987 Reed Holdings, Inc.

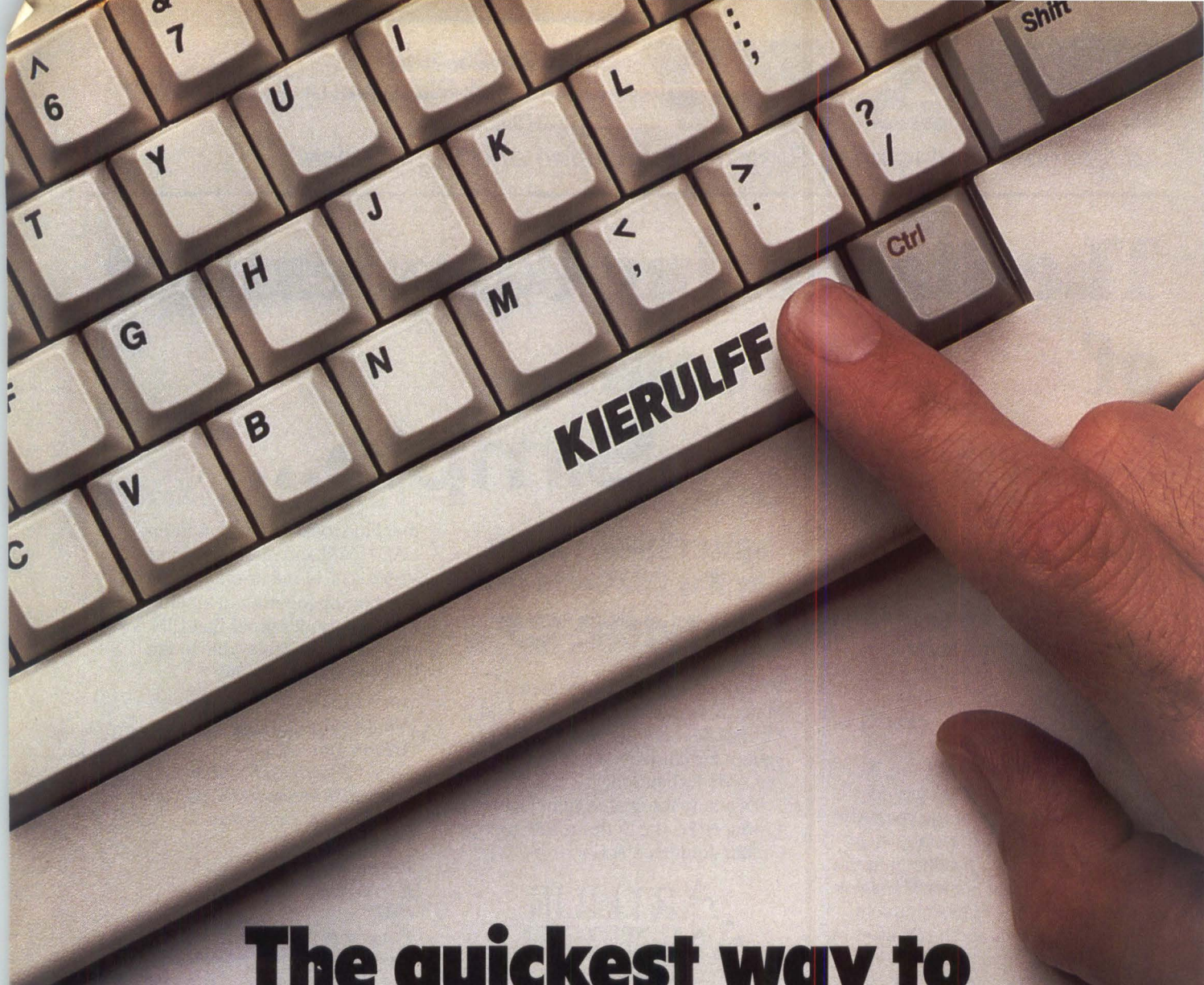

# The quickest way to get in touch with AT&T.



Make contact with Kierulff.

That's where you'll find AT&T's complete range of computer products and peripherals. From FAX machines,

PC 6300s, Industrial Workstations, 6500 Multifunction Communications Controllers and the entire 3B family. Plus everything in between.

You'll also find a line of professionals on AT&T systems who do much more than deliver hardware.

These people are experts at configuring AT&T systems for industrial applications. And more importantly, they'll help you pinpoint the exact AT&T product you need to meet your specific requirements. Which may not sound like much, unless you consider the breadth of AT&T's product line.

Kierulff people can provide other extras, too. Like

fast and accurate AT&T technical information. Service and repair. AT&T extended warranties. And the industry's only Systems Product Guide—the most complete single-source of product information available on AT&T and 21 other leading manufacturers of systems, computer peripherals, software and accessories. And it's yours free for the asking.

Best of all, Kierulff's 30 stocking locations nationwide ensure you'll get the AT&T product you need, when you need it. Maybe that's why we're AT&T's largest distributor.

So call 1-800-FOR PROS. It'll get you in touch with the Kierulff office nearest you.

And a quick AT&T solution.

**KIERULFF**  
Our people are the best part.

system, of which there were over 70 installed at the year's end, is an offshoot of parent company Bolt Beranek and Newman Inc.'s many years of experience in multiprocessor-based network switching. It uses packet-switching techniques to directly interconnect multiple processors over 4M-byte-per-second paths that do not require point-to-point connections. Packet switching overcomes a disadvantage of the more commonly employed hypercube architecture, namely, the difficulty of communicating with non-adjacent nodes, at the cost of reduced channel bandwidth.

The tightly coupled Butterfly system is expandable from two to 256 nodes. Each node contains a single-board computer with a 68000 or 68020 processor and up to 4M bytes of shared memory, plus a microprogrammed coprocessor that manages memory references and message transfer. Each node can also accommodate a serial or Multibus controller.

NCUBE Corp., which began deliveries in December 1985 and installed over 50 systems last year, makes use of hypercube architecture. The NCUBE/four provides up to 16 IBM Corp. PC/AT-compatible nodes (providing 30 million instructions per second and 8 million floating-point operations per second) on four four-node

modules. The NCUBE/seven accommodates 16 to 128 nodes in a desk-side chassis; and the NCUBE/ten supports 64 to 1,024 nodes in 64-node increments.

Each node consists of a proprietary 32-bit microprocessor with 128K bytes of local memory and 11 pairs of 10M-bit-per-second DMA channels—10 for links to other nodes and one for system I/O. The I/O channel can move data at 90M bytes per second in either direction, for a total bandwidth of 180M bytes per second.

Floating Point Systems Inc., in addition to its range of multiple array-processor implementations (jointly marketed with DEC), offers a parallel-processor line based on the Inmos Ltd. transputer (see "Transputers and occam target concurrent processing"), nine of which were installed during 1986.

Floating Point's T Series systems are organized in a hypercube configuration. Each node consists of a transputer, a vector processor and 1M byte of dual-ported, 160M-byte-per-second shared video RAM. An adapter expands each transputer link to four, providing 16 channels per node.

A special-purpose node connected to all other nodes handles system I/O. In this system node, the vector processor is replaced by a disk

---

**Buyers of multiprocessor systems should view the need for anything more than recompilation with extreme caution.**

---

## Transputers and occam target concurrent processing

The occam programming language, developed by Inmos Ltd., is designed specifically for concurrent, or parallel, processing. The language is based on three principles: processes communicate by message passing through explicitly defined one-way channels, do not share variables and synchronize only when communicating. These principles eliminate many problems associated with shared memory (such as contention, and cache and main-memory coherency); permit parallel processes to be remapped from a single processor to multiple processors by simply recompiling the code; and allow program execution to be controlled by the availability of data.

Inmos designed its transputer family of RISC (reduced instruction set computer) microprocessors specifically to provide efficient execution of the occam language. Transputers feature on-chip static RAM, programmable external memory controllers, integral timers and four bidirectional serial (up to 20M-bit-per-second) direct-memory access links, which implement occam channels. Internal memory bandwidth is one 32-bit word per clock cycle (or 80M bytes per second at 20 MHz); external memory runs at up to one-third of that rate.

Inmos introduced its first transputer, the T414, in October 1985. It included 2K bytes of onboard static RAM, and delivered 639K bytes of single-precision (32-bit) Whetstones at 20 MHz using software

floating-point operations. In December 1986, the company announced the T800, which incorporates 4K bytes of RAM and a 64-bit floating-point unit. It operates at up to 30 MHz. Inmos claims that the T800 can perform 4 million Whetstones in its initial, 20-MHz implementation.

Occam processes operate on two levels—active and waiting. On a single transputer, active processes run on a round robin basis, with each running to completion or until forced to wait for communication. The number of transputers available is defined at compile-time, and processes are distributed accordingly.

In order to facilitate real-time processing, the active process list is split into high- and low-priority segments, with low-priority segments running only if the high-priority list is empty. Typical response time to a high-priority request is 1 msec, with a 4-msec maximum.

As an illustration of the power of transputer networks, a massively parallel processor employing 311 T414s, Meiko Ltd.'s Computing Surface, runs at 3 billion instructions per second. Upgrading to the T800, which has an integral floating-point processor, is expected to yield 360 million floating-point operations per second. Floating Point Systems Inc., a leading array processor supplier, has also introduced a transputer-based parallel processor product line.

**Growth in the multiprocessor segment will likely come at the expense of (and be resisted by) established players.**

controller interfacing a front-end processor, currently a MicroVAX-based workstation. Other I/O controllers for the system node are under development.

#### Supermini makers remain reluctant

Only two of the established superminicomputer suppliers, Concurrent Computer Corp. (formerly Perkin-Elmer Data Systems) and Gould Inc. (formerly S.E.L.) offer multiprocessor systems.

Concurrent's 3200MPS product line tightly couples a 3230XP, 3250XP or 3280 CPU and up to nine attached processors via a 64M-byte-per-second bus, under the control of a proprietary, real-time, multitasking operating system (OS/32). The auxiliary processors are identical to the central processor but are configured (and dynamically reconfigurable) as IOPs or auxiliary processing units. Each 3200MPS has a shared memory interface that permits several 3200MPS systems to access an external shared memory system or to cross-couple two 3200MPS systems.

Like the Concurrent systems, Gould's Concept/32 family of superminicomputers can be configured as asymmetric multiprocessor systems. A 26.67M-byte-per-second SELbus supports up to eight attached processors. Unlike the 3200MPS, however, the Gould systems are loosely coupled, with each processor having its own 16M-byte address space. Thus, different operating systems can be downloaded from the host to the nodes. The multiSEL, announced in January, is a prepackaged, four-processor configuration of the single-board microSEL implementation of the Concept/32 architecture.

Although not classified as general-purpose

minicomputers, Tandem Computers Inc.'s NonStop fault-tolerant systems are multiprocessors and fit best within the established superminicomputer category. NonStop systems consist of two to 16 loosely coupled processors connected by dual, 20M-byte-per-second buses. (It can be argued that, for fault-tolerant applications, the added robustness outweighs the cost of the additional physical memory and communications overhead of loose coupling.)

I/O is handled by dual-ported controllers connected to the separate I/O buses of two processors. As the market leader in the fault-tolerant systems area, Tandem has probably installed more multiprocessor systems than the rest of the industry combined.

#### Technology pat, market dicey

Few technology issues remain unresolved in the multiprocessor field. Loosely and tightly coupled systems of minicomputer and microprocessor-based APUs are available from several suppliers. Dynamic load balancing is now common, and the capability to parallelize tasks is emerging.

Differences between implementation strategies usually revolve around the specific tasks for which the systems are best suited. In general, low-end multiprocessors are used in workstation, network server and multiuser applications, while multimicrocomputers and minicomputer-based multiprocessors compete with superminicomputers. The major questions are the size of the available market and the number of suppliers that it can support.

Of the superminicomputer suppliers, only Concurrent and Gould have fielded multipro-

## Companies mentioned in this article

#### Areté Systems Corp.

821 Fox Lane  
San Jose, Calif. 95131  
(408) 432-1200  
Circle 313

#### Argonne National Laboratory

Mathematics and Computer  
Science Division  
9700 S. Cass Ave.  
Argonne, Ill. 60439  
(312) 972-7231  
Circle 314

#### BBN Advanced Computers Inc.

10 Fawcett St.  
Cambridge, Mass. 02238  
(617) 497-3700  
Circle 315

#### Concurrent Computer Corp.

2 Crescent Place  
Oceanport, N.J. 07757  
(201) 870-4712  
Circle 316

#### Convergent Technologies Inc.

2700 N. First St.  
San Jose, Calif. 95150  
(408) 434-2848  
Circle 317

#### Encore Computer Corp.

257 Cedar Hill St.  
Marlboro, Mass. 01752  
(800) 336-2673  
Circle 318

#### Flexible Computer Corp.

1801 Royal Lane, Building 8  
Dallas, Texas 75229  
(214) 869-1234  
Circle 319

#### Floating Point Systems Inc.

Box 23489  
Beaverton, Ore. 97005  
(503) 641-3151  
Circle 320

#### Gould Computer Systems

6901 W. Sunrise Blvd.  
Fort Lauderdale,  
Fla. 33310  
(305) 587-2900  
Circle 321

#### Ing. C. Olivetti & C. S.p.A.

Via G. Jervis 77  
I-10015 Ivrea, Italy  
Circle 322

#### Inmos Inc.

Box 16000  
Colorado Springs,  
Colo. 80935  
(303) 630-4000  
Circle 323

#### Masscomp

1 Technology Park  
Westford, Mass. 01886  
(800) 451-1824  
Circle 324

#### Meiko Ltd.

Bristol, England  
044-272277409  
Circle 325

#### NCR Corp.

General Systems Division  
1700 S. Patterson Blvd.  
Dayton, Ohio 45479  
Circle 326

#### NCUBE Corp.

Suite 2030  
1815 N.W. 169th Place  
Beaverton, Ore. 97006  
(503) 629-5088  
Circle 327

#### Sequent Computer Systems Inc.

15450 S.W. Koll Parkway  
Beaverton, Ore. 97006  
(800) 854-0428  
Circle 328

#### Stratus Computer Inc.

55 Fairbanks Blvd.  
Marlboro, Mass. 01752  
(617) 460-2000  
Circle 329

#### Tandem Computers Inc.

19333 Valco Parkway  
Cupertino, Calif. 95014  
(408) 725-6000  
Circle 330

#### Tolerant Systems Inc.

81 E. Dagget Drive  
San Jose, Calif. 95134  
(408) 946-5667  
Circle 331

# A LOT OF VARS ARE HAPPY THAT FACIT IS BEHIND BARS

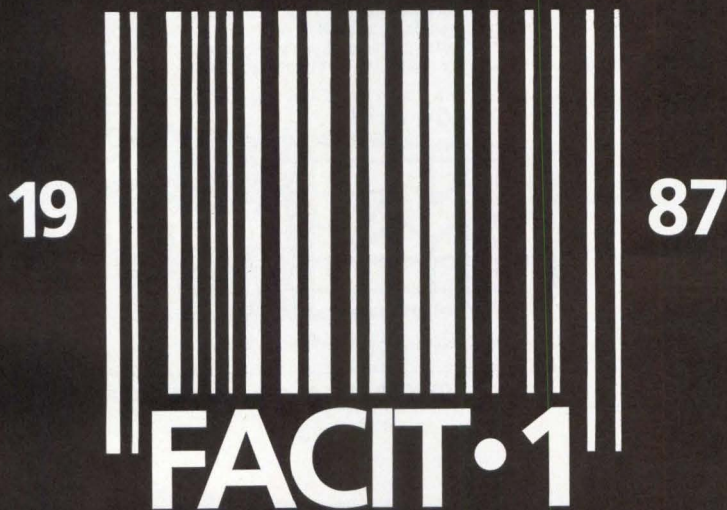

There's good reason why:  
Facit printers are the toughest  
machines going.

Just consider the ordeal a bar code  
printer endures day in and day out.  
It's no wonder more and more  
resellers insist on Facit. For readability  
as much as reliability, they know their  
customers can depend on Facit line  
after line, time after time. And that  
means you'll spend less time trouble-  
shooting problems for your customers.  
And more time building your business.

Facit printers are engineered to  
withstand the most strenuous  
environments. Everything ... from  
forms handling to fast precise output  
... is engineered to perform one  
way—*perfectly!* Facit makes a quality  
printer for every printer need—from  
dot matrix to laser. With a host of  
features and options for customized  
applications.

Facit also has one of the best service  
support programs in the business, to  
keep you and your customers running  
around the clock. We also have  
generous margins, to help you offer  
your customers trouble-free systems  
at competitive prices.

So put Facit to work for you ... for a  
bar code job no ordinary printer can  
pull off. Write Facit, Inc., 9 Executive  
Park Drive, PO Box 334, Merrimack,  
New Hampshire, U.S.A., 03054.  
Or call (603) 424-8000. You'll be glad  
you did. After all, when it comes to  
your reputation, isn't quality always  
on the line?

*Facit 4528 Matrix Printer—  
with resident bar code  
capability.*



*Facit 7080 Laser Printer—  
for demanding high-volume  
workloads.*



*Facit B3350 Matrix  
Printer—versatility for a  
variety of applications.*

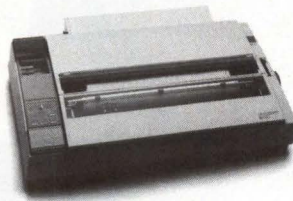

# FACIT

QUALITY RUNS IN THE FAMILY.  
CIRCLE NO. 56 ON INQUIRY CARD

# FOUL-WEATHER FRIEND.



**Field Printer. The portable printer that won't quit going when the going gets tough.**

A lightweight portable printer that prints an amazing range of character styles in any weather environment without missing a beat.

See FieldPrinter in action at Booth 105, Convention Center.



Immediate Business Systems  
2100 Riverchase Center  
Birmingham, Alabama 35244



CIRCLE NO. 84 ON INQUIRY CARD

## A Complete PC Graphics Workstation For Under \$150

Introducing

### PC PLOT IV

Advanced Graphics Terminal Emulation Software

PC Plot IV is MicroPlot's newest graphics terminal emulation software package for IBM PC's and compatibles enabling complete emulation of Tektronix 4010/4014 and 4027, DEC VT-100/200, VT-52, and Retrographics VT-640 terminals. An enhanced version, PC Plot IV Plus, further allows complete Tektronix 4105 emulation. Features include XMODEM and ASCII file transfer, user configurable online help, script language, modem commands, programmable function keys, convenient PC-DOS execute mode, autodial from telephone directory and more.

Expanded graphics capabilities include support of an IBM professional graphics display system providing 256 colors, a graphics screen dump to LaserJet printers, Hewlett-Packard, IBM and Houston Instruments pen plotter drivers and numerous other auxiliary capabilities for customized applications.

To find out more about MicroPlot's new PC Plot IV call **1-800/654-1217**

Over 15,000 Original PC Plots Sold!



**MicroPlot**

TM

659-H Park Meadow Rd. Westerville, Ohio 43081 614/882-4786

CIRCLE NO. 85 ON INQUIRY CARD

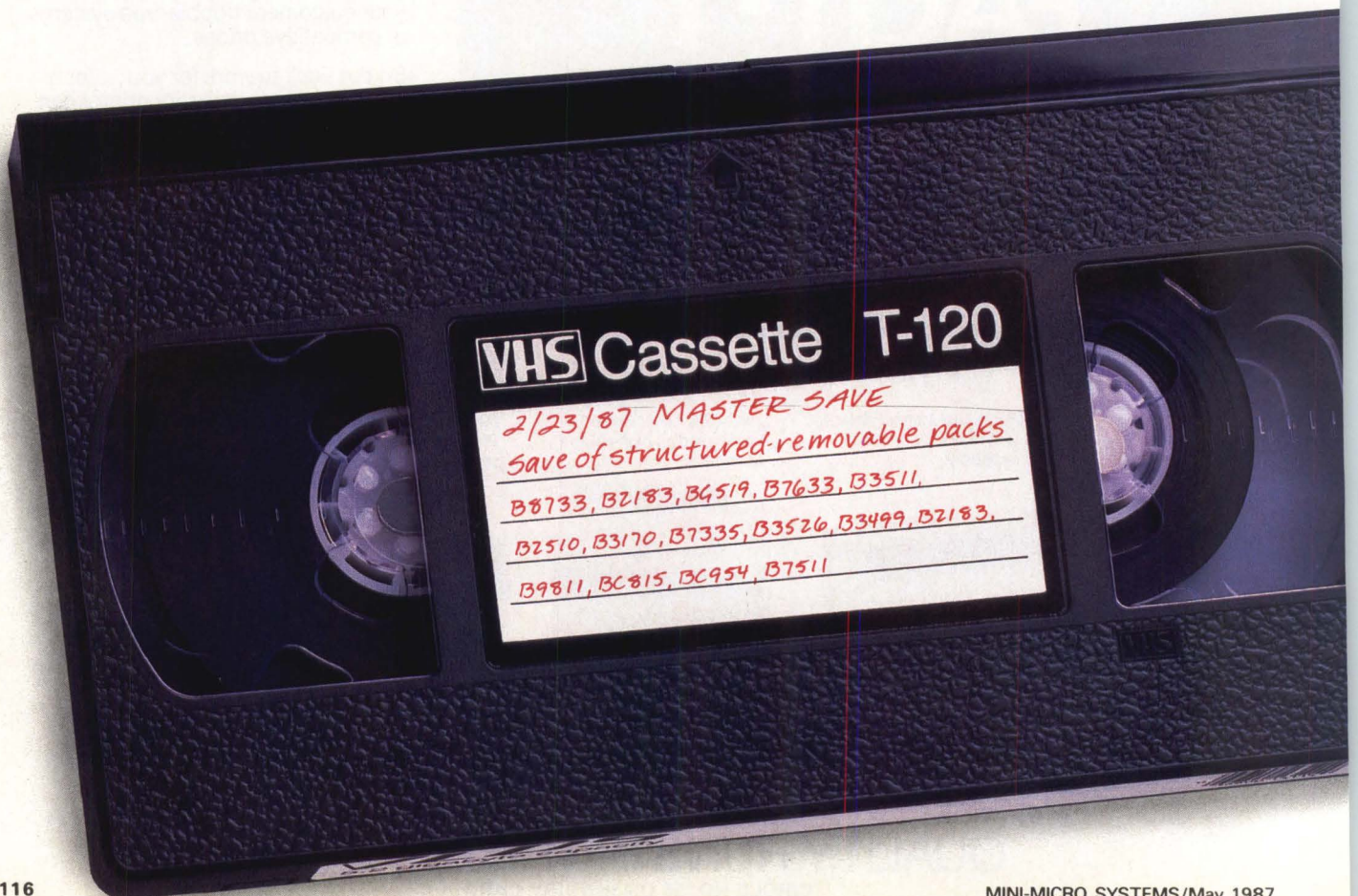



processors (as opposed to distributed processing configurations like DEC's VAXcluster). This situation probably exists because of the large physical size and cost of processor increments, but also says something about superminicomputer manufacturers' perception of the importance of multiprocessors.

Similarly, in the mainframe market, most participants have chosen to remarket microprocessor-based systems—e.g. IBM-Stratus, Siemens-Sequent, and Unisys (Burroughs-Convergent and Sperry-Areté)—rather than develop their own multiprocessor systems.

The fault-tolerant market segment may exemplify the market as a whole. Despite optimistic forecasts in the early part of the decade, which lured several start-ups and much venture capital into fruitless efforts, the multiprocessor subsegment of the on-line transaction-processing market yielded just over a billion dollars in revenues last year. Most of that went to just two companies (Tandem, \$836 million, and Stratus, \$125 million).

The consensual forecast for the computer industry as a whole for the remainder of the decade predicts growth of roughly 10 percent per year. If the forecast is right, growth in the multiprocessor segment would presumably

have to come at the expense of (and be resisted by) the established players. New market entrants such as minisupercomputer and RISC suppliers will provide fierce competition.

Clearly, a pitched battle will rage (with a high casualty rate) between superminicomputer, minisupercomputer and multimicrocomputer/parallel-processor suppliers for what is now the high end of the superminicomputer market. The flexibility of multiprocessor systems (variable granularity, incremental growth capability and fault-tolerance etc.) suit them well for niche markets and midrange multitasking applications.

Thus, attractive opportunities exist for suppliers and OEMs who clearly establish realistic objectives. For their part, system integrators should employ a few key criteria in making purchasing decisions, i.e. evaluate the fit between application and multiprocessor-implementation strategy, the range of performance required, the price/performance characteristics across the range and the survivability of the candidate suppliers. □

Interest Quotient (Circle One)  
High 489 Medium 490 Low 491

---

**Andrew Allison** is a management consultant specializing in minicomputer and microcomputer technology, products and markets. Before establishing his practice in 1977, he had spent over 12 years with Digital Equipment Corp., Rolm Corp. and Advanced Micro Devices.

---

## In the world of information storage, this is known as a warehouse.

Imagine storing up to 5.2 gigabytes of data on a standard T-120 VHS high-energy cassette. Now you can with Honeywell's new VLDS system (Very Large Data Store).



You no longer need thirty 10-inch reels of 6250 bpi 9-track computer tape. Or 5,200 double-sided 5¼-inch floppy disks. Or fifty-two 5¼-inch WORM optical disks. Just VLDS and a single standard VHS cassette.

VLDS provides a 4-megabyte-per-second sustained transfer rate, a media cost of less than .21¢ per megabyte, and a bit error rate of  $10^{-12}$ . And to assure easier, cost-effective system integration, optional high-performance imbedded controllers are available, including SCSI and VAX/VMS.

VLDS is the latest advancement in Honeywell's line of magnetic tape systems that have been unsurpassed in quality and support services for over 30 years.

For details on VLDS, and its OEM pricing, contact Tom Balue, Honeywell Test Instruments Division, Box 5227, Denver, CO 80217-5227. (303) 773-4491.

**Together, we can find the answers.**

# Honeywell

CIRCLE NO. 57 ON INQUIRY CARD

© 1987 Honeywell Inc.

**WHY TEAM UP WITH  
A BIG COMPUTER COMPANY  
THAT PLAYS AGAINST YOU?**

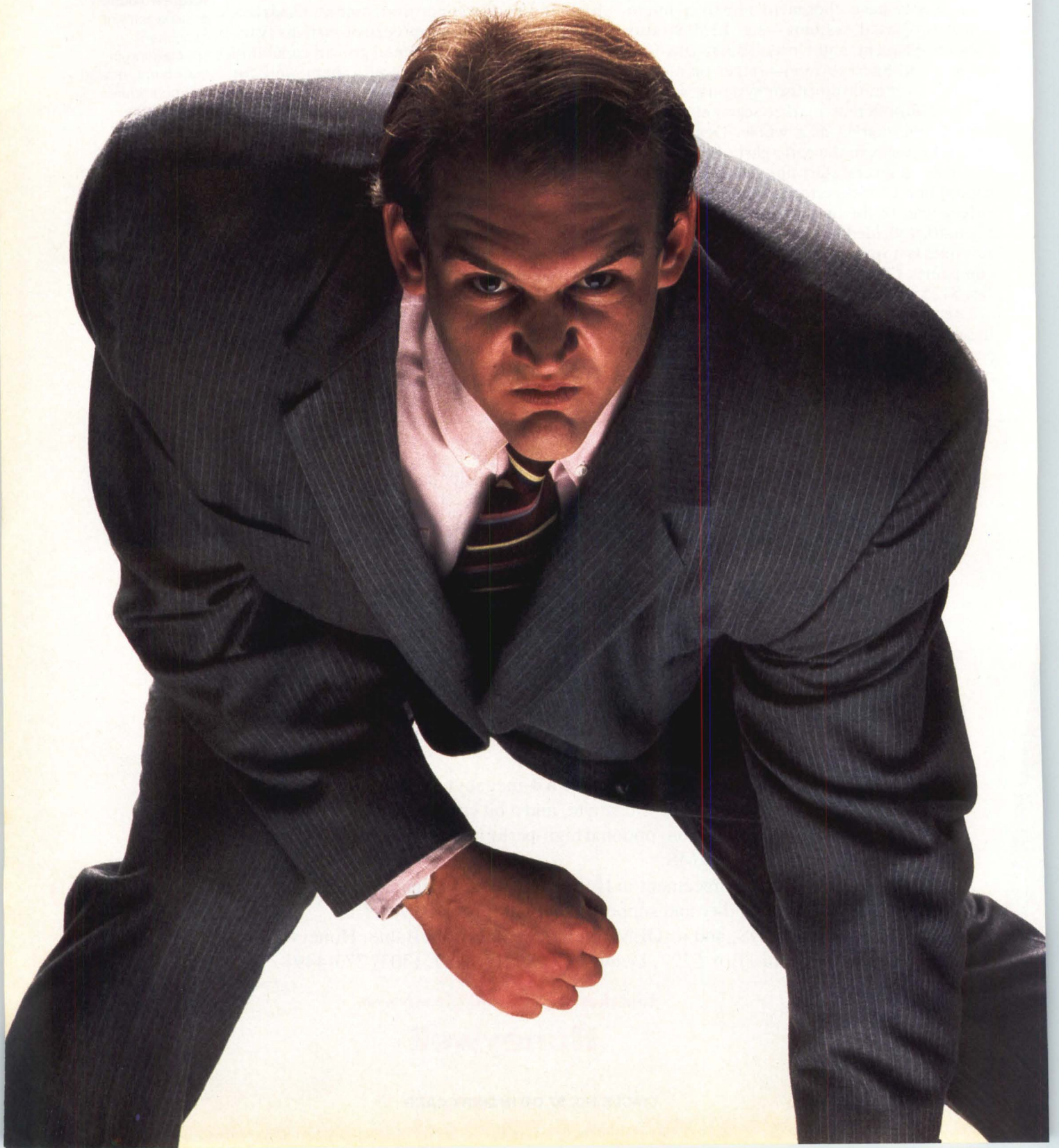

# WE'RE ONE BIG COMPUTER COMPANY THAT'S ALWAYS ON YOUR SIDE.

## **With NEC you make the sale. You make the profits.**

Value added reselling is not the easiest business in the world. And it can get tougher if you're dealing with the wrong computer company.

NEC is different. We work with you. Not against you.

VARs like you are the only direct sales force we have. And we wouldn't have it any other way.

## **Why more and more VARs are sold on NEC's Preferred VAR program.**

Because it works to your advantage.

For one thing, NEC offers larger discounts than the competition. Which means higher margins for



you. Discounts are applied across all product families. So you can concentrate on selling the products your customers want. Not the ones the computer company is pushing. And our program doesn't penalize you to get in the game. Because NEC understands your business, we give the flexibility to ramp up gradually.

And when it comes to helping you sell, no one beats NEC. We provide an aggressive co-op plan. We train your sales force. We even have a teaming program to assist you in establishing co-licensing agreements in geographic markets you can't cover.

## **With NEC, you're selling one of the biggest and hottest product lines in the business.**

NEC isn't just one of those one-product companies. We have an extensive line of mini and micro computers and printers.

Our newest mini computer family is the Astra<sup>®</sup> XL series.

Take the Astra XL/32.

It's a powerful, flexible 32 user system based on the UNIX<sup>®</sup> operating system and an open architecture.

Then there's our new



APC IV family of personal computers. The machines for the power user. And we're backing it with a multi-million dollar tv, radio and print advertising campaign entitled, "Take it to the limit."

And then there's our legendary line of reliable Pinwriter<sup>®</sup> and Spinwriter<sup>®</sup> printers.

Products are only one ingre-

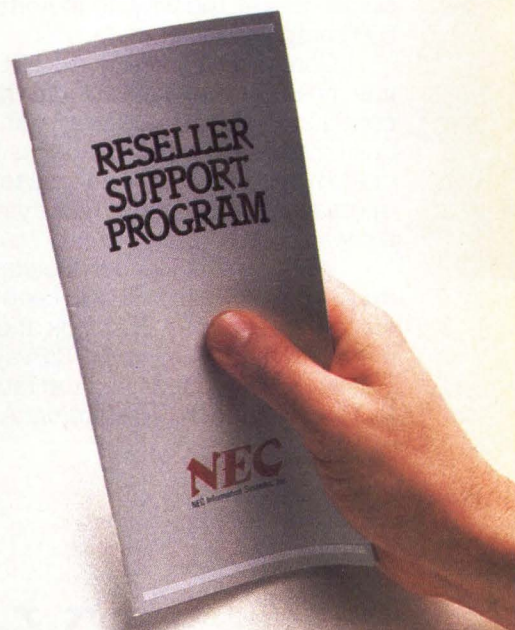

dient. Support is another. Being able to convert your software is one more. We have a program for that too. A program that provides all the conversion tools and assistance you need.

## **Put a \$13 billion leader on your side.**

Call NEC. We keep pushing the limits in computers and communications. With our products. And with a program that helps our VARs sell them.

To receive our VAR information kit, call 1-800-343-4419.

In Massachusetts call (617) 264-8635. Or write to NEC Information Systems, Inc., Dept. 1610, 1414 Massachusetts Ave., Boxborough, MA 01719.

# NEC

UNIX is a trademark of AT&T Bell Laboratories.

**C&C** Computers and Communications

**CIRCLE NO. 58 ON INQUIRY CARD**

It's a simple fact of VAR life. Some vendors just don't supply you with the kind of hardware you need to reach a wide range of customers. Fortunately, there is someone with more for you to sell. Hewlett-Packard. And what we have for you is the broad, fully compatible HP 3000 family.

The breadth of the HP 3000 family means that you can meet the needs of a wide range of customers. From small businesses all the way up to Fortune 500 companies.

Compatibility across the HP 3000 line means greater flexibility in the configurations you can offer your customers. And it means that as your customers grow, they'll be able to upgrade easily—without modifying software.

What's more, Hewlett-Packard quality and support will help keep your customers satisfied. Just look at our record. In the 1986 *Datapro Survey*, Hewlett-Packard received top ratings for Overall Support Satisfaction. And in

the 1986 *VARBUSINESS Annual Report Card Review*,<sup>®</sup> our current VARs gave us highest ratings among major vendors for Quality of Products, Provision for Hardware Maintenance, and Overall Impression of Vendor.

Added to all of this are some of the most attractive financial incentives in the industry. An entire arm of our sales force dedicated exclusively to supporting you. And our ongoing commitment to always asking "What if..." about your business needs.

So if you're looking to sell more, look to those who give you more to sell. Hewlett-Packard.

For more information call 1 800 367-4772, Dept. 694E.

® Reprinted with permission from *Computer Systems News (VARBUSINESS)*.

 **HEWLETT  
PACKARD**  
*Business Computing Systems*

**CIRCLE NO. 59 ON INQUIRY CARD**

*we never  
stop  
asking*

*"What if..."*

You'll sell more  
if you've got more  
to sell.

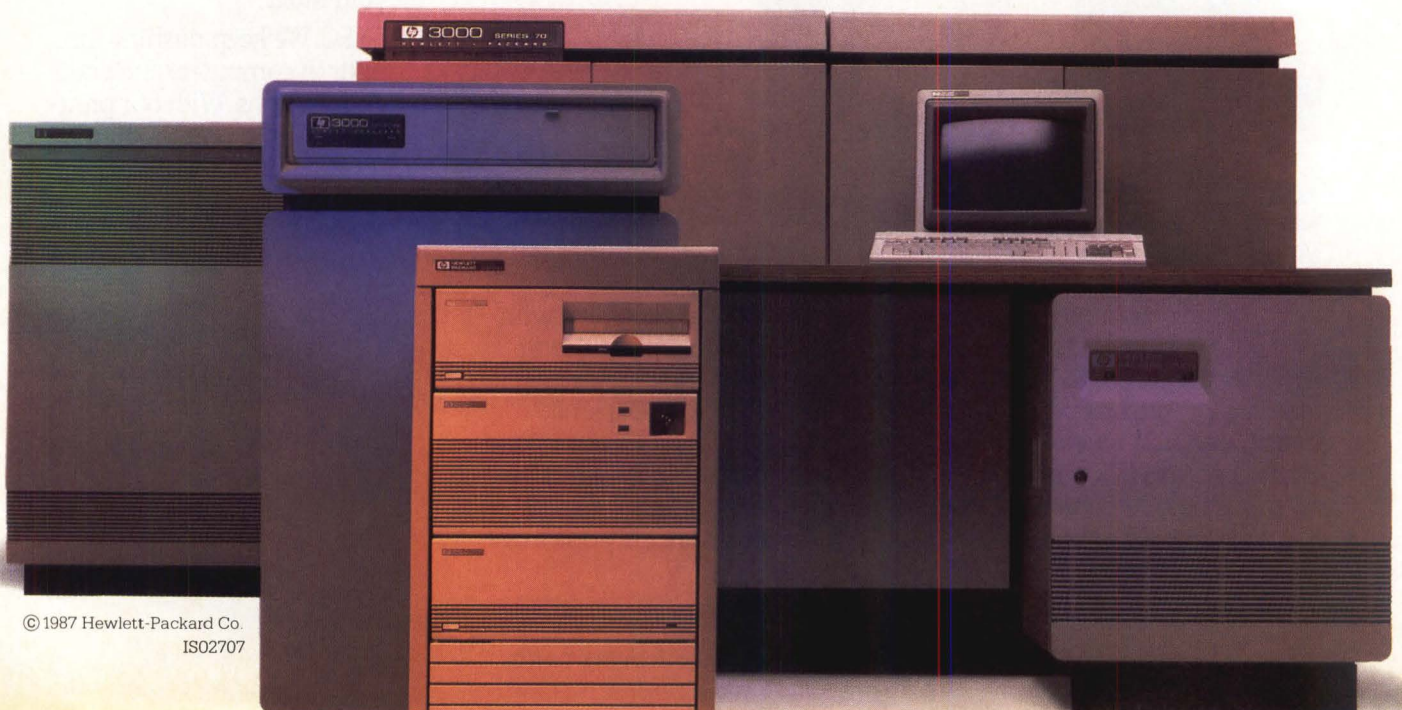

# GRAPHICAL INTERFACE SPEEDS PROGRAMMING

Use of a graphics-based user interface, called 'Picture Programming,' and an application generator accelerates VAX software production

**Craig Hill**, Cortex Corp.

Programmer productivity is a chief goal of software developers today. One method of decreasing the time—and, hence, the money—that good software development requires is to program in a graphical mode. In this approach, software developers use pictures—icons, line drawings and so forth—to produce complete applications.

One company, Cortex Corp., recently introduced CorVision, which uses a technique called "Picture Programming" to bring this capability to programmers developing software for Digital Equipment Corp. VAXes, in-

cluding the MicroVAX. It works in much the same way that hardware engineers use workstations and computer aided design/computer aided manufacturing systems to simplify design tasks. That is, application developers sitting at an IBM Corp. PC/AT or compatible (including VAXmate) use CorVision to draw up a complete design for a piece of software. That includes data-dictionary fields, file structures, menus, screens, reports and custom logic. Then, by pushing a button, the developer produces a completely linked and compiled application for the DEC VAX in machine language—and complete system documentation—directly

from the drawings.

All of this vastly reduces the time it takes to create an application by hand coding in a language like COBOL. Indeed, a recent estimate based on studies of users of the current Cortex product, Application Factory, which uses much of the same underlying technology, suggests that it may cut the time required by a factor of 10 or more.

In effect, CorVision automates most of the software life cycle. It establishes an integrated design, development and maintenance environment that automatically generates complex, multiuser applications. These applications run on VAX-fami-

## DEC uses graphics on COBOL generator

**Michael Tucker**

The use of graphics to improve programmer productivity has become a main theme of modern software development. Increasingly, developers are finding that not only is a picture worth a thousand words but also 10,000 lines of code.

One of the premier exponents of the graphics approach is Digital Equipment Corp. Last February, for example, DEC introduced a COBOL generator with a graphics-based interface. The product runs on the VAX and allows developers to use a mouse or cursor keys to create flowchart-like diagrams that are then converted into modules of COBOL source code.

DEC's VAX COBOL Generator is not a fourth-generation language for the computer-illiterate, or even for the computer literate in a great hurry. Instead, it's meant for experienced COBOL programmers who would use the generator in much

the same way a senior management-information system (MIS) officer might use an entry-level assistant—to handle the actual, tedious task of coding to specifications already defined by an expert.

As such, the DEC Generator probably addresses the needs of MIS professionals who must work in COBOL but would like some of the advantages of a code generator—arguably this is a different market from the one targeted by Cortex Corp. with CorVision. Yet, in the long run, the larger meaning of the products is the same. Both demonstrate that the majority of computer users, even unusually sophisticated users, are demanding that computers take up the most uncreative, repetitive aspects of software development.

**Michael Tucker** is a former associate editor of *Mini-Micro Systems*.

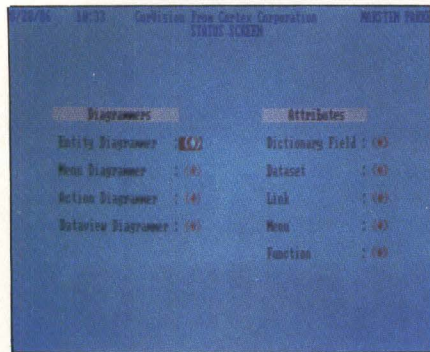

**Picture Programming** allows an application to be symbolically represented by a series of diagrams depicting the structure and relationship of its components. This and the following screen shots show how CorVision can be used to develop an application. Here, the Status Screen displays red "gateways" into the diagrams and attributes of the application components.

ly computers using the VMS operating system. The product includes an interactive graphics environment that captures the application's design. This graphics environment is resident on the PC/AT or compatible and is tightly coupled through a transparent link to the VAX, where a central repository stores the information captured on the PC and drives an application generator based on Application Factory.

CorVision links front-end diagramming with back-end code-generation capabilities. Today's application-development tools are usually for only one end or the other.

### Eliminates hand coding

Most software-production automation tasks so far, have concentrated on the back end of the development cycle. Typical back-end tools include fourth-generation languages (4GLs) and code, or application, generators. 4GLs streamline the coding portion of development through powerful instruction sets with procedural and non-procedural components, data dictionaries and programming and formatting aids. Code, or application, generators automate to varying degrees the laborious process of hand coding. The functionality of the generator output varies significantly

among products. Some application generators only generate program modules, which need to be linked by hand. Others generate completely linked and compiled applications.

More recently, tools have appeared on MS-DOS machines to automate the front end, or design phase, of the life cycle. Most of these provide an automated drawing board that allows production of numerous design diagrams employing structured diagramming techniques by manipulating symbols and icons. They improve productivity in much the same way as word processing by allowing easy editing and storage of graphic images. None, to date, capture the necessary information in a format usable by back-end tools for code generation.

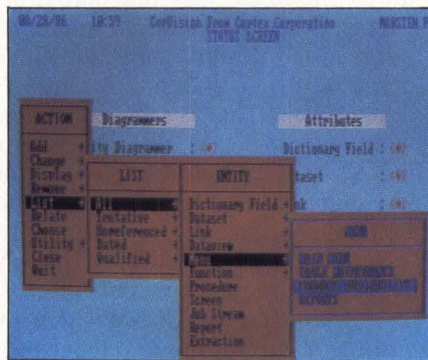

**Opening a gateway with a mouse,** a developer receives pop-up menus that provide on-line access to all existing application specifications. The developer also uses the gateways to navigate among diagrammers and attribute screens.

CorVision automates the software-development life cycle by capturing the necessary information with the diagrams on the PC to drive a generator on the VAX. The CorVision generator uses the proven technology of the Application Factory to produce complete functional applications. This allows a developer to move directly from visual design specifications or pictorial representations to a complete compiled and linked application.

Both CorVision and Application Factory rely on a tightly integrated series of modules to specify, document and generate applications. An "intelligent guidance system" recom-

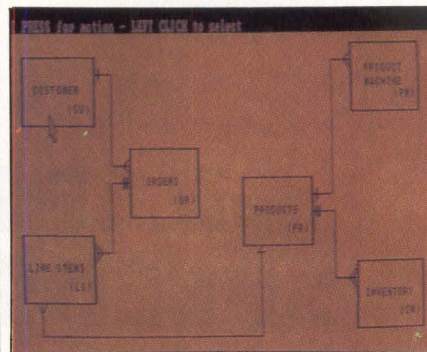

**The entity diagrammer** allows developers to visually represent the structure and form of the data. Relationships between each of the files are diagrammed using standard diagramming methods.

mends the next logical step in the design and specification process and interactively keeps track of the completeness and consistency of the specification. In Application Factory, specification occurs by interactively filling in forms managed by facilities on a VAX. The specifications are resident in a central repository, which provides input for an application generator.

With CorVision, in contrast, a developer defines a complete view of the application using Picture Programming techniques. This involves using line drawings, icons, pop-up menus and windows instead of forms. Icons represent application components and relationships. Context-sensitive pop-up menus facilitate direct navigation between specification modules by pointing at "visible gateways" on the screen with a mouse. This visual-development environment provides extremely fast access for viewing and updating parts of an application.

For example, a user points with a mouse to an icon in a diagram that represents a file. A window opens to display the record layout to which it is associated. The user then points to another visual gateway for a field in the record layout and another window opens to display the field definition. The field definition includes a label and such information as the length of the field and whether characters are alpha or numeric, plus field

# VAX Managers forget us every day.

Perfect terminal emulation software is perfectly forgettable. It installs quickly, runs easily, and performs every task that every user wants. You set it, forget it, and never hear about it again.

That's a perfect description of Reflection 2. The most forgotten terminal emulation software in the world, because it makes your job so easy.

#### **Versatile, accurate, easy to install**

Reflection 2 offers complete VT220 emulation (with optional Tektronix 4010). Quick, accurate file transfers with our proprietary protocol, or others. And easy installation of host file transfer software: Just upload it once from any PC with a single keystroke.

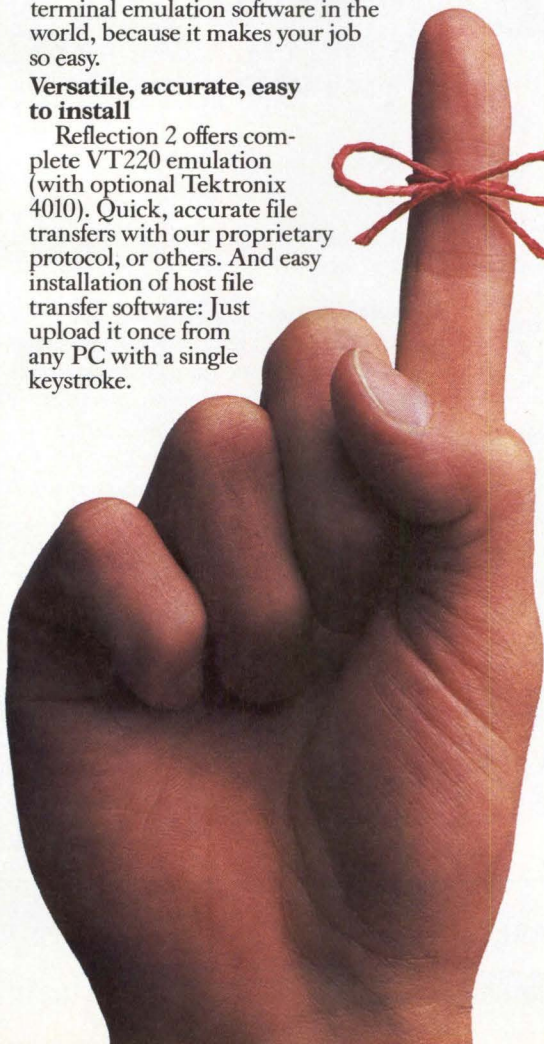

#### **Expanded command language**

Our robust command language lets you create log-on routines which run at the touch of a key. Or automate any complex user requirement, from ALL-IN-1 to VAX mail.

#### **50,000 smiling Reflection users**

Only Reflection 2 lets PC users start a file transfer, then go back to 1-2-3, WordPerfect, or other DOS programs while the file transfer continues. And PLUS, an optional feature, will back-up PC hard disks to your VAX automatically. Back-ups can even be initiated from the VAX and execute after working hours.

#### **Multinational keyboard and technical support**

Reflection 2 comes with DEC multinational and national replacement character sets, European keyboard support, and help screens in English, French, and German. Unlimited technical support is no extra cost, by telephone or telex.

#### **FREE evaluation copy**

If you are an MIS manager supporting 25 or more users, send for a free, fully-functional evaluation copy of Reflection 2 PLUS. If you don't agree it makes your job easier, return it with no obligation.

See how forgettable terminal emulation can be. Just remember this name: Reflection 2.

#### **To order, for information, or your FREE evaluation copy, contact:**

Walker Richer & Quinn, Inc.  
2825 Eastlake Ave. East  
Seattle, WA 98102 USA  
Telephone: USA (206)  
324-0350 Telex: 311743  
WRQ UR

Dealer and distributor inquiries welcome.

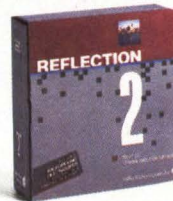

## **REFLECTION™**

S E R I E S

From Walker Richer and Quinn.  
We're making connectivity easier.

VAX, All-In-1 and VT220 are trademarks of Digital Equipment Corporation. 1-2-3 is a trademark of Lotus Development Corporation. WordPerfect is a trademark of WordPerfect Corporation.

CIRCLE NO. 60 ON INQUIRY CARD

**\*  
YOUR MICROVAX II IS TOO  
EXPENSIVE TO RISK IN  
I/O INTERFACING.**

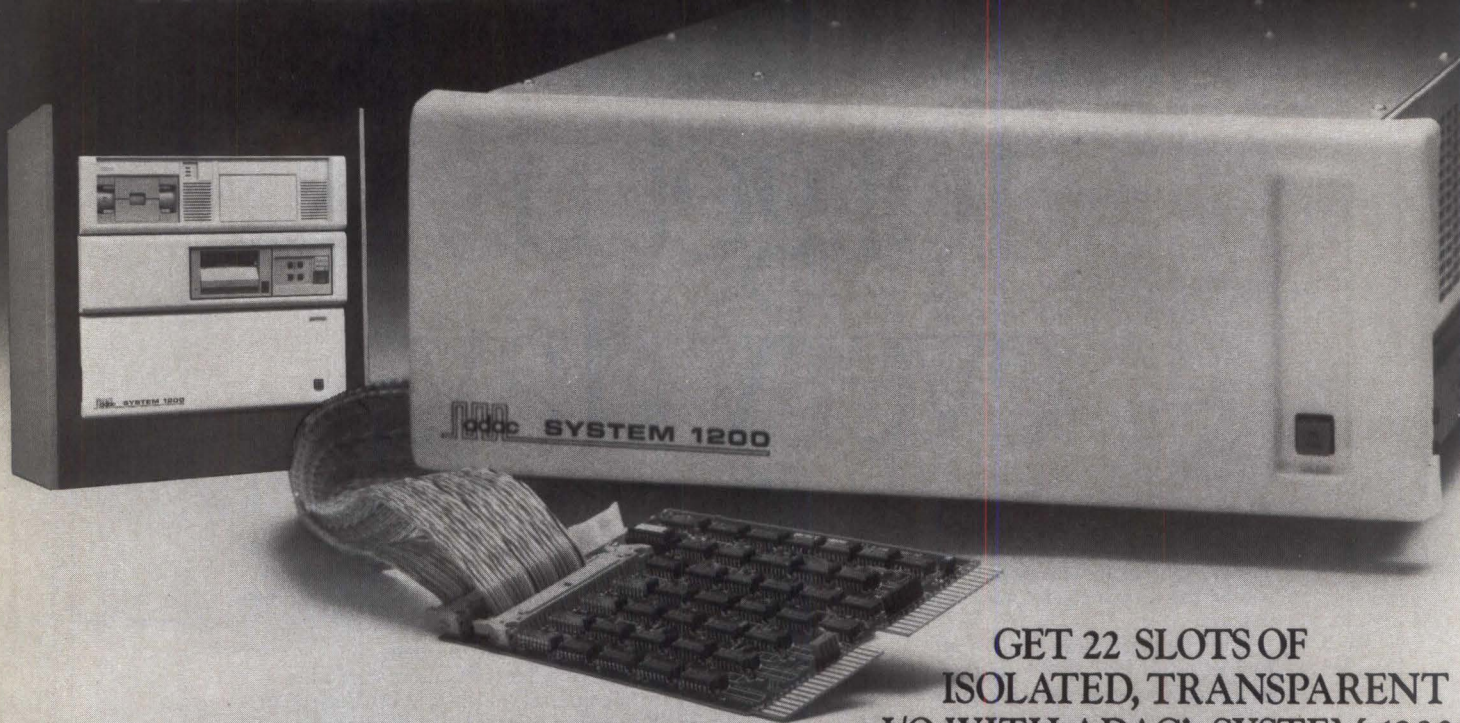

**GET 22 SLOTS OF  
ISOLATED, TRANSPARENT  
I/O WITH ADAC'S SYSTEM 1200  
AND 1953 BUS REPEATER.**

Just one slot in your MicroVax II for Model 1953 Bus Repeater will plug-connect you to 22 half-quad or 11 full-quad slots (or any combination) of I/O in our very versatile System 1200 enclosure. Common mode risk and inconvenient I/O wiring to your MicroVax II is eliminated.

**Ready-To-Run ADLIBVMS Sub-Routine Software**

In addition to offering the industry's most complete selection of Q-BUS boards, ADAC offers the ADLIBVMS library of ready-to-use sub-routine software. ADLIBVMS supports fast, real-time, interrupt-driven data acquisition and control...eliminating hours and hours of software driver writing. 29 Callable sub-

routines are written in the same format as DEC device drivers.

**Complete Signal Conditioning, Too**

ADAC has the right multi-channel boards for all manner of analog I/O including thermocouples, strain gauges and RTD's, with appropriate cold junction compensation, linearization and bridge completion. Choices also include a variety of digital I/O, serial I/O, CMOS RAM, DMA, pulse, frequency and switch-sensing modules.

*For the best way to interface your MicroVax II with I/O signals, get details on the System 1200 "no risk" solution from ADAC today.*



**DISKBASYS**

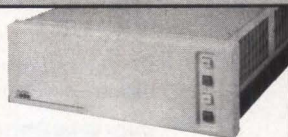

**PROMBASYS**

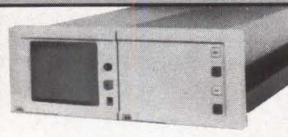

**MICROBASYS**



**PICOBASYS**



70 TOWER OFFICE PARK, WOBURN, MA 01801 (617) 935-6668 Telex 951802  
Philadelphia (609) 596-4447 • Los Angeles (213) 476-6535 • Cupertino (408) 973-7829 • Chicago (312) 980-3191  
Dallas (214) 701-8008 • EUROPEAN HEADQUARTERS: SURREY, ENGLAND (Tel) 3727-42577 Telex 918179

\*Registered trademark Digital Equipment Corporation

**CIRCLE NO. 61 ON INQUIRY CARD**



edits such as range checks. The user then edits the definition and returns to the original diagram. The graphic representation of the file is automatically revised to reflect any changes in the definition. Likewise, manipulation of icons directly results in automatic changes to the underlying specification.

The central repository on the VAX stores all the specifications with its changes. It contains the information that drives the format and content of the PC diagrams as well as the input specification for the application generator on the VAX. Because all PCs in a CorVision development environment share the same central repository, changes made by one developer automatically show up on another de-

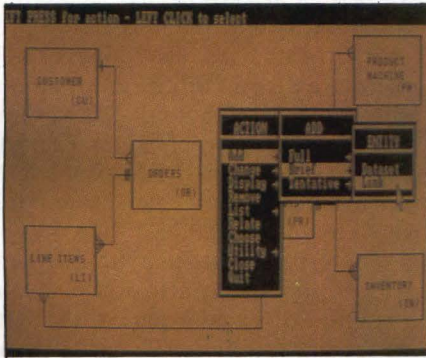

**Using the pop-up menus** in the entity diagrammer, the developer can specify the relationships between the various files by defining the link structure.

veloper's workstation. In this way, the central repository helps maintain consistency within a development team and makes projects easier to manage.

### Maintenance becomes a problem

Applications developed with CorVision are maintained in the same way they are developed. Because the description of the application is kept in the central repository, changes are implemented by changing the descriptions. Once again, a developer uses Picture Programming techniques to manipulate diagrams, icons and their underlying specifications. The modifications or enhancements are tracked by the intelligent guidance system and stored in the central

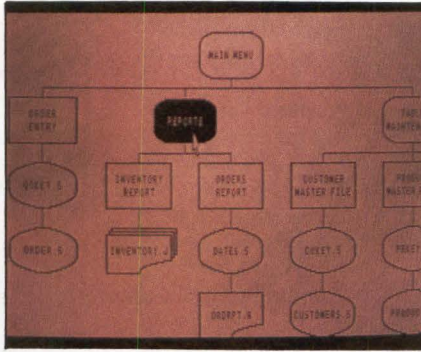

**The menu diagrammer** visually represents the logical flow of the application from the user's perspective. Different icons represent menu choices, functions, screens, reports and custom procedures. Additions or changes to the menu diagram result in the restructuring of the application.

repository. The CorVision generator then regenerates only the affected parts of the application code as well as changes to data and data structures in the production application. Because software maintenance typically consumes 60 percent of the software life cycle, CorVision could significantly improve productivity in this costly and difficult task.

The use of Picture Programming to capture high-level specifications results in the automatic generation of an estimated 95 to 98 percent of the code necessary for a production application. The remaining, customized, code is written in a proprietary

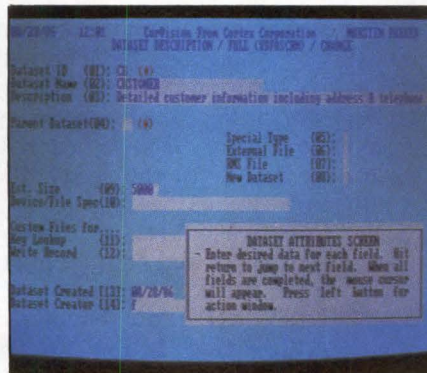

**A dataset attribute screen** allows developers to window in on the icon representing a file to display its attribute screen, which defines the details of the structure of the file.

4GL language called "Builder," or is added from libraries of 3GL routines. Builder programming is done with the help of an additional Picture Programming tool called "Action Diagramming." Action Diagramming structures, visualizes and self-documents the program code interactively as the developer types at the terminal. Syntax, consistency and completeness checks are performed by CorVision, on-line and in conjunction with the central repository and intelligent guidance system.

Custom coding is typically used to add specific procedures, such as check-digit routines and complex cross-field validations. CorVision provides numerous hooks throughout the design and specification process

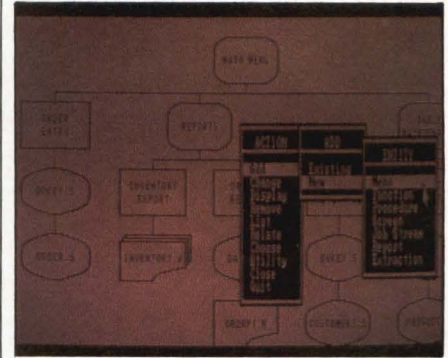

**With pop-up menus** in the menu diagrammer, developers can specify the major components and structure of the applications.

for the addition of custom logic where desired. Hooks insert flags at places in an application where the program executes the custom code. For example, the input of a credit card number in a data-entry screen might trigger a routine to validate a check digit of the number.

CorVision supports the larger theme of an open architecture. It uses DEC's RMS (Record Management Services) file system and, in the near future, Rdb, DEC's relational database software. The product supports VAX clusters, DECnet and standard VMS data types. This means programmers can build applications that share data with other DEC applications. In addition, the generated application can use routines or existing

# REPRINTS

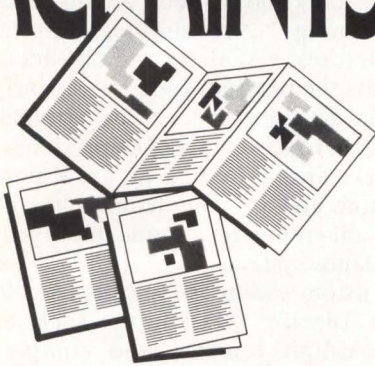

Whenever your company activities or products are reported in the pages of a Cahners magazine... whether in a feature article... in a news story... or an article on new products or technological innovations... we can custom-design a Reprint for you to use in your sales, marketing, and public relations programs.

You can also include your advertising message in the Reprint so that it becomes your own special company promotion piece. Reprints can be a single sheet or a multi-page brochure. And the cost is surprisingly low, whether your order is in the hundreds or the thousands.

Consider these many uses:

- Mailing to your promotion list or customer list
- Distribution at trade shows or conventions
- As a leave-behind or sales tool for your sales staff
- As a public relations or public service release
- New product announcements

## Mini-MicroSystems

For details contact:  
CAHNERS REPRINT SERVICES  
P.O. Box 5080  
Des Plaines, IL 60017-5080  
(312)635-8800

## DEC DIRECTIONS VAX PROGRAMMING

### Spec summary

- **Product:** CorVision
- **Company:** Cortex Corp., 138 Technology Drive, Waltham, Mass. 02154, (617) 894-7000
- **Machines supported:** IBM Corp. PC/AT and compatibles and Digital Equipment Corp. VAXes and MicroVAXes
- **Memory requirements:** 640K bytes on the PC/AT, 4M bytes on the VAX
- **Communications supported:** RS232C, Ethernet
- **Price:** \$50,000 to \$175,000, depending on the VAX model.

program libraries written in any DEC-supported language. This feature facilitates application integration with external devices.

Because the computer generates the code, CorVision applications are bug-free. Automatic compilation to machine code at the time of generation means that the application is efficient. Production applications perform at a level that is comparable to those written in a compiled 3GL such as COBOL or BASIC.

### Benchmarks show compression

It is difficult to determine exactly how much CorVision will improve programming productivity. However, much may be inferred from usage studies of Application Factory. These reveal dramatically compressed software development time. For example, a survey completed this year of 26 applications at 22 sites found an average improvement ratio in application-development productivity of 13 to 1.

The survey used function-point analysis, a language-independent measure of programmer productivity, to measure project resources using Application Factory relative to a 3GL such as COBOL. In the study, the number of screens per application ranged from five to 204 with an average of 48. The number of reports ranged from zero to 90 with an average of 17. The average number of files was 37 with a range of four to 108. The smallest application was the equivalent of 8,000 lines of COBOL, while the largest was 250,000 lines. The average was 75,000 lines.

At an E.I. DuPont de Nemours & Co. installation in Camden, S.C., Application Factory delivered a 600 per-

cent productivity improvement in a reimplementing with more functionality. The application, used in a fiber-manufacturing environment, was a tracking application that required interfacing to five external devices used in weighing, packaging and distributing unfinished goods in process. In this case, DuPont received estimates from three development shops of 28, 36 and 38 worker-months. Using Application Factory, the project required two people and only two and a half calendar months, or five worker-months.

Such dramatic productivity increases are directly attributable to automation of a major part of the software development life cycle. CorVision, by adding the visualization of application design to proven generator technology, takes the automation process much further than Application Factory. It makes relationships among various application components easier to understand. Diagrams at the same time convey more information and are a precise medium of communication. An easy-to-use graphical design and specification environment should further enhance the productivity improvements documented with CorVision's predecessor. □

**Craig Hill** is the president and founder of Cortex Corp., Waltham, Mass. Prior to founding Cortex, he was the director of Eastern Operations at Inforex and held positions at IBM Corp.

Interest Quotient (Circle One)  
High 495 Medium 496 Low 497

**NEW**

# At Last, Hardcopies of your Best Designs in 10 Seconds.

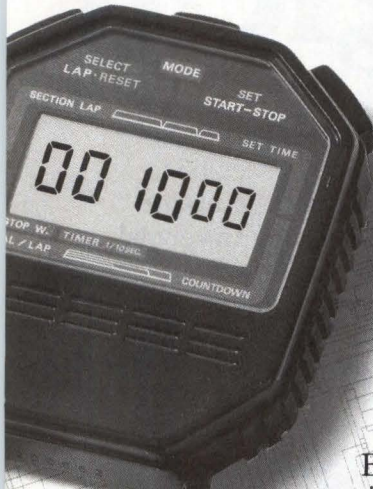

**Quality computer graphics design takes time.**

But you shouldn't have to wait for a high-quality, economical copy of your effort.

The Seikosha VP-95II provides the hardcopy you need, quickly and easily... regardless of the CRT or high-resolution graphic display you use.

The VP-95II is completely 1280 × 1280 pixels-compatible. It accepts dot clock frequencies to **80 MHz** and has standard RGB input.

The direct thermal line printer uses wide (8.5-inch) paper, so you can do same-size copies directly from your CRT with excellent 152.4 dots/inch resolution.

And the VP-95II has been designed to provide complete, trouble-free operation. You can replace paper in seconds and the printer's

precision feed mechanism has completely eliminated paper jamming.

To capture your design ideas on hardcopy, simply turn on the VP-95II and it will begin printing immediately.

If you want a copy of your best design efforts in seconds, find out how quickly and easily you can begin getting beautiful results with the Seikosha VP-95II.

**Call or write us today.**

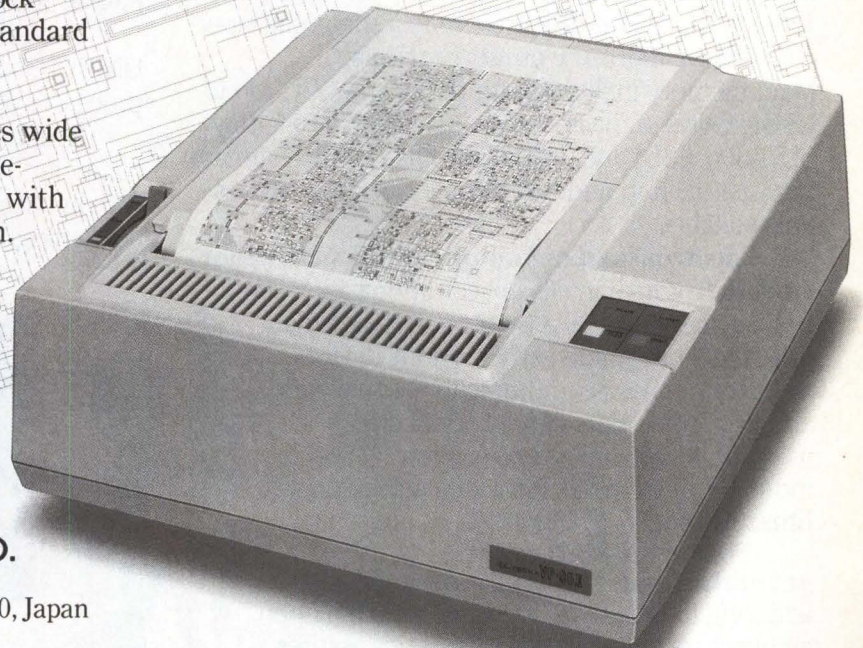

**For OEM:**

**SEIKOSHA CO., LTD.**

SYSTEM EQUIPMENT DIVISION

4-1-1, Taihei, Sumida-ku, Tokyo 130, Japan

Phone: +81-3-625-4610 direct

Telex: 262-2247 SEIKO J Fax: +81-3-624-8666

**For Distribution:**

**Seikosha**

America Inc.

1111 Macarthur Blvd., Mahwah, NJ07430

Phone: 201-529-4655

**See us at Comdex/Spring '87  
Booth 1128 EAST HALL**

**CIRCLE NO. 62 ON INQUIRY CARD**

# We've taken our to its next logical

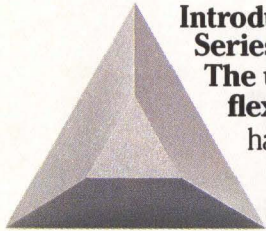

## Introducing the VME Delta Series™ Computer System:

### The ultimate in system-level flexibility.

For years, Motorola has supplied OEMs and system integrators with the widest selection of VME boards on the market—all based

on the most advanced VMEbus technology available.

We have now taken this experience a major step forward.

First, we formed an entirely new division to better serve our OEMs and focus on their needs as VME boards and system customers. And then, our new Microcomputer Division designed the next level of systems integration—and *your* next logical system conclusion.

### The VME Delta Series Computer System.

The VME Delta Series redefines the concept of configurability in VME systems. For starters, take its compact enclosure. It contains 12 VME slots—plus room for up to four disk drives and a streaming tape.

### Major memory configurations.

Main memory includes both parity and ECC. Up to 1.3 Gigabytes of mass storage is satisfied by a family of ST-506, ESDI and SMD disks. Quarter-inch streaming tape backup and half-inch, 9-track tape drives are available.

### Unsurpassed communications with other

**worlds.** Through intelligent communication controllers, the VME Delta Series can handle data from local or remote asynchronous devices. Industry standard communications networks and host computers can be connected using protocols such as SNA, Bisynch and more. For high-speed, local area networking, Ethernet® and TCP/IP controllers are available.

**From MC68020 to the next generation—just plug in the board.** By adhering to industry-wide standards, the open architecture of the VME Delta Series assures the future viability of your product. Its system

CPU uses the popular MC68020 microprocessor. You can continue to upgrade to new generations and even faster versions as they become available.

### We can get you up and running in record

**time.** The VME Delta Series is available with all the OEM tools needed to bring your applications up to speed and up to date—fast! The UNIX® System V/68™ Release 3 operating system offers a rich environment for developing multi-user and networking applications. Other enhancements include Remote File Sharing—allowing users to share files among different computers transparently.

Also available are development tools and high-level languages such as C, FORTRAN, Pascal, and COBOL.

Powerful data management software includes UNIFY®, Oracle®, Informix®, color graphics, word processor, spreadsheet and project manager.

**The team behind your team:** Our Microcomputer Division team can help your OEM team with application and technical support through 100 field offices located world-wide.

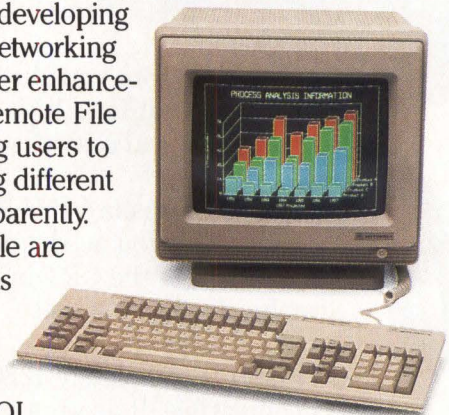

We also provide comprehensive support in a wide variety of other areas—software and application update newsletters and a toll-free hotline—such as the one below.

Use it now—to find out more about our new Microcomputer Division in general and more about the VME Delta Series in particular.

**1-800-521-6274**



# VME experience conclusion.

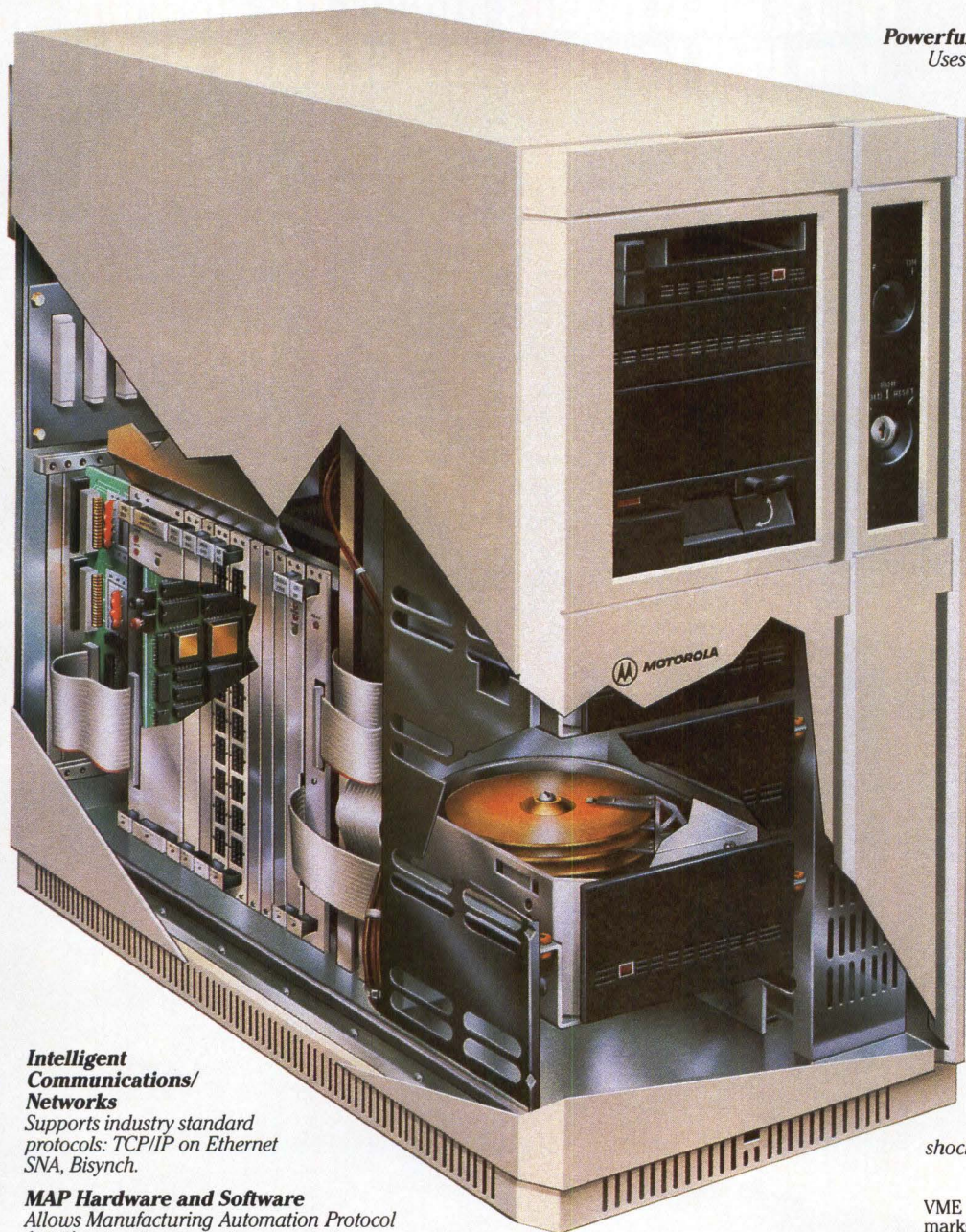

#### **Intelligent Communications/ Networks**

Supports industry standard protocols: TCP/IP on Ethernet, SNA, Bisynch.

#### **MAP Hardware and Software**

Allows Manufacturing Automation Protocol (MAP) technology to be incorporated into products.

#### **Data Management Software**

Supports UNIFY, Oracle, Informix relational database systems.

#### **Office Automation Software**

Color graphics, word processor, spreadsheet, project manager and many more packages available.

#### **Powerful Processors**

Uses 32-bit MC68020 MPU and MC68881 Floating Point co-processor; easy upgrade to next generations.

#### **UNIX-V3/Remote File Sharing (RFS)**

Uses SYSTEM V/68-compliant with AT&T's UNIX System V Release 3 with RFS for easy system networking. Real-time executives are available.

#### **Large Main Memory**

Up to 16 Megabytes, with both ECC and parity.

#### **Flexible Mass Storage, up to 1.3 Gigabytes**

Internally, up to 4-5/4" mass storage drives including floppy and Winchester drives, 1/4" streaming tape, SMD disk and 9-track tape interfaces for additional external mass storage.

#### **Open/Expandable Architecture**

Twelve I/O connector/transition slots; 12-slot VMEbus card cage (A32/D32); whopping 450 watt power supply covers any expansion need.

#### **Local and Remote Diagnostics**

Provides for cost effective remote testing via modem and comprehensive local testing.

#### **Complete Development Support**

Supports C, Pascal, FORTRAN, COBOL and other high-level languages; varied development tools available.

#### **Attractive/Sturdy Enclosure**

Floormount enclosure meets UL, CSA, VDE, IEC, FCC requirements; shock mountings for disk drive protection.

VME DELTA SERIES, System V/68 are trademarks of Motorola, Inc. UNIX is a registered trademark of AT&T. Ethernet is a registered trademark of Xerox Corporation. INFORMIX is a registered trademark of Informix Software. ORACLE is a registered trademark of Oracle Corporation. UNIFY is a trademark of UNIFY Corporation.



**MOTOROLA Microcomputer Division**

Approaching our technology from your point of view.

CIRCLE NO. 78 ON INQUIRY CARD

# Flexibility.

**That's what makes Ampex the number one OEM terminal maker in the world**

*Flexibility is the key to Ampex's relationship with OEMs. We offer you more choices than any other terminal manufacturer around - in firmware, in monitors, in keyboards, in phosphors. Plus, you get all the usual customization in plastic and keycap colors, and your own logo.*

*But we don't stop there. We offer the deep base, a packaging concept designed especially for OEMs. The deep base provides more internal capacity than the standard terminal base. Still, it's compatible with the entire Ampex family of terminal products and options. And we build your product to our high quality standards. You get the benefit of our large volume and efficient manufacturing in a product that is uniquely yours. Call us today and find out just how flexible we are.*

*Ted Odolecki*

Ted Odolecki, Business Manager — Terminals

## AMPEX

*Make the right choice. Call Ampex Computer Products Division at 800-538-7838 (in CA: 800-231-1036) Ampex. We stand for excellence.*



Check out our full line of ASCII, ANSI/DEC & PC Terminals.

**CIRCLE NO. 63 ON INQUIRY CARD**

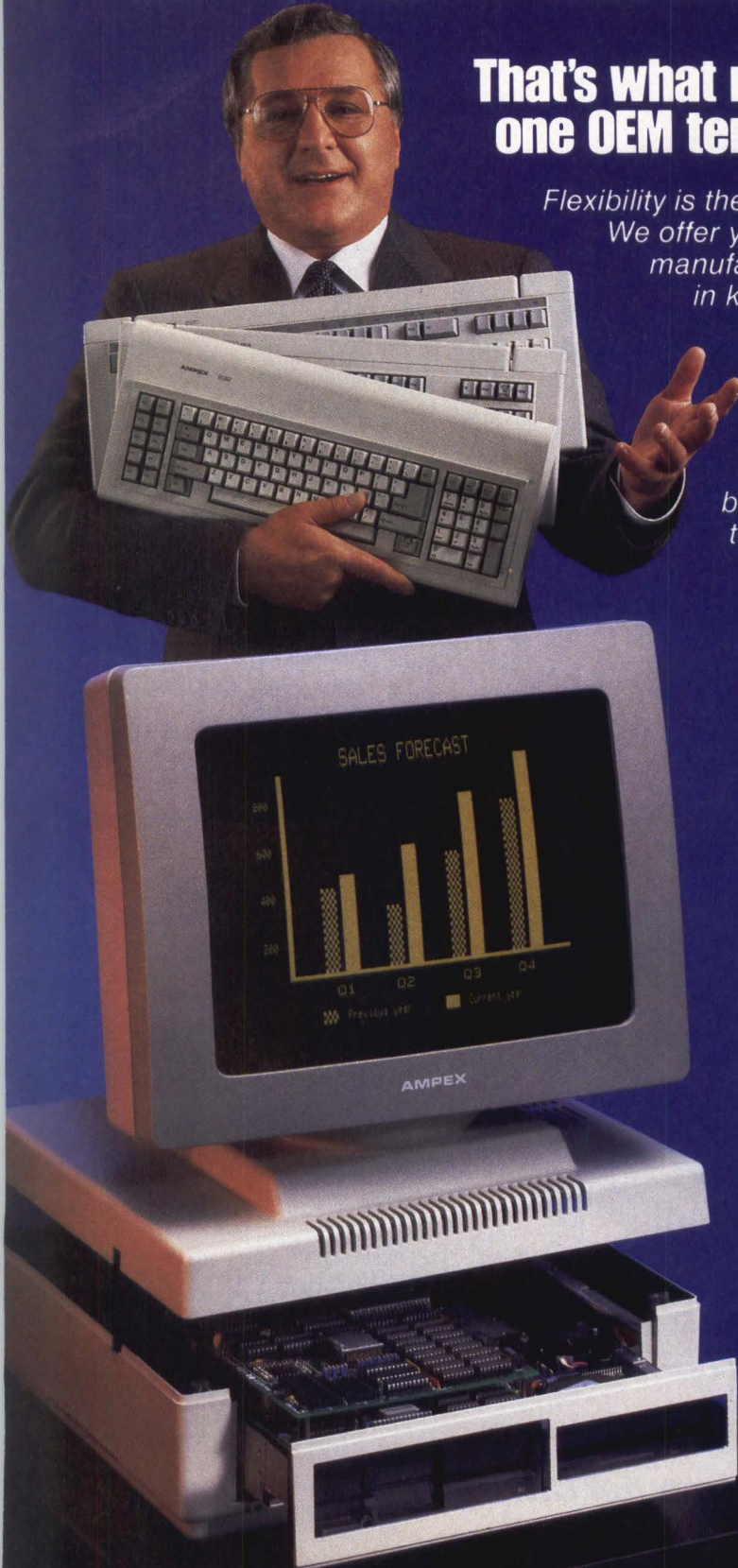

# NEW PRODUCTS

## SYSTEMS

Megan Niels, Staff Editor

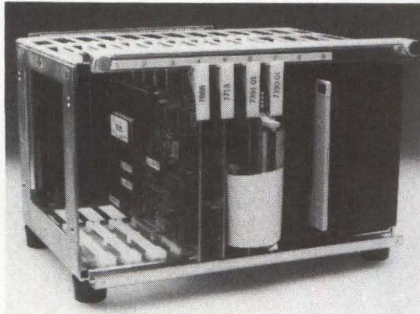

### Computer aims at industrial uses

- IBM PC/XT compatible
- Two models
- Microsoft MS-DOS 3.2

System 2, an IBM PC/XT-compatible computer, is geared toward factory-floor applications. The unit offers IBM PC/XT compatibility and is based on Microsoft's MS-DOS 3.2 operating system. Model 10 supplies 128K bytes of CMOS static RAM, expandable to 128K bytes, and two semiconductor storage units. Model 20 adds a 3½-inch flexible disk drive. Both systems contain a serial port and up to 23 expansion slots. \$1,195, model 10; \$1,595, model 20. **Pro-Log Corp.**, 2560 Garden Road, Monterey, Calif. 93940, (408) 372-4593.

Circle 401

### Computer sports 80386 processor

- 2M bytes of RAM
- Parallel port
- IBM PC/AT compatible

Equipped with an Intel 80386 microprocessor, the CP80386Top computer runs at 16 MHz. The IBM PC/AT-compatible unit supplies 2M bytes of RAM, parallel and serial ports, and a slot for the 80287 math coprocessor. A 1.2M-byte flexible disk drive reads, writes and formats in 360K-byte mode. The unit runs more than twice as fast as the PC/AT. \$4,995. **Distribution Plus**, 7313 Grove Road, Frederick, Md. 21701, (301) 695-0478.

Circle 402

### Computer suits IBM PC/AT

- 80286 CPU
- 1M byte of memory
- 1.2M-byte disk drive

An IBM PC/AT-compatible computer, the ST-100 utilizes an 80286 microprocessor. The unit provides 1M byte of memory, a 1.2M-byte flexible disk drive and flexible and rigid disk controllers. Options include an 80287 coprocessor. \$1,295. **IBI Systems Inc.**, 6842 N.W. 20th Ave., Fort Lauderdale, Fla. 33309, (305) 978-9225.

Circle 403



### Three-model desktop based on 80286 processor

- 12 MHz
- 8.1M bytes
- 8-, 16-bit slots

Available in three configurations, the 12-MHz Compaq Deskpro 286 replaces the original Deskpro 286. The unit uses an Intel 80286 dual-speed processor, up to 8.1M bytes of memory and up to 80M bytes of fixed disk storage. The model 1 sports 256K bytes of RAM and a 1.2M-byte flexible disk drive. Models 20 and 40 offer 640K bytes of RAM. Up to five 8- and 16-bit expansion slots are available. \$2,999, model 1; \$3,999, model 20; \$4,999, model 40. **Compaq Computer Corp.**, 20555 FM 149, Houston, Texas. 77070, (713) 370-0670.

Circle 404

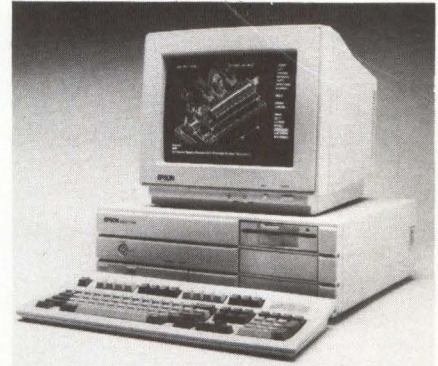

### Computer employs 80286 processor

- 640K bytes of RAM
- Six expansion slots
- RS232C, parallel port

An IBM PC/AT-compatible personal computer, the PowerMate 1 employs an 80286 processor running at 8 MHz. The unit comes standard with 640K bytes of RAM expandable to 8.6M bytes, a 1.2M-byte flexible disk drive and a rigid disk controller. It includes six expansion slots, an RS232C port and a parallel port. MS-DOS 3.2 and GW BASIC 3.2 are provided. \$1,995. **NEC Information Systems Inc.**, 1414 Massachusetts Ave., Boxborough, Mass. 01719, (617) 264-8000.

Circle 405

### 286 computer offers nine slots

- 6, 8, 10 MHz
- 640K bytes of RAM
- 1.2M-byte flexible drive

The Equity III+ computer utilizes an 80286 microprocessor running at 6, 8 or 10 MHz. It offers 640K bytes of RAM, expandable to 15.5M bytes, and a 1.2M-byte flexible disk drive. A second configuration supplies a 40M-byte rigid disk drive with a 28-msec average access time. The IBM PC/AT-compatible unit features built-in serial and parallel interfaces and nine expansion slots. \$2,695, \$3,895 with rigid disk drive. **Epson America Inc.**, Suite 450, 1901 Ave. of the Stars, Los Angeles, Calif. 90067-6067, (213) 539-9150.

Circle 406

# The people who make Seagate





the first name in disc drives:

# Marti

Before we invest millions of dollars developing a new product, Seagate marketing specialists like Marti Spieller spend lots of time talking to our customers to find out exactly what they want.

"We found that people who use PCs for CAD/CAM graphics or financial applications need more storage capability," Marti said. "But they want a storage system that's modular so they can start small and add on when they need more capacity."

Marti's research helped develop Seagate's DISC DATA MANAGER™, a storage subsystem that expands modularly from 80 MB to over a gigabyte.

"We use multiple drives in the DISC DATA MANAGER so you buy exactly the amount of storage that you need," Marti said. "You can upgrade as your needs grow simply by installing an additional drive. Multiple drives also allow people to keep duplicate copies of important files for added protection."

Customers have come to expect this kind of relentless emphasis on meeting their needs from Seagate. That's one reason they've bought more than 5 million of our 5¼" hard disc drives.

Seagate's reputation is built by its people. If you think your drives should be made by dedicated professionals like Marti, call us.

800-468-DISC. In California, 800-468-DISK.

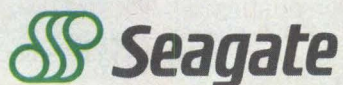

The first name in disc drives.

CIRCLE NO. 87 ON INQUIRY CARD

**Laser printers hold 3M bytes of RAM**

- 300-dpi resolution
- Four emulation modes
- 25 fonts

The LaserPro Silver Express and Gold Express laser printers provide 300-dpi resolution and font-download capabilities. They emulate Diablo 630, Epson FX-80, Hewlett-Packard LaserJet and NEC 3550 devices. The first model targets CAD/CAM and desktop publishing applications. It features 768K bytes of RAM, 25 bit-mapped fonts and a proprietary Command Language. The second unit has a memory-expansion option that doubles the standard 1.5M bytes of memory to 3M bytes. It offers HP's HPGL graphics language. \$2,995, Silver Express; \$3,695, Gold Express. **Office Automation Systems Inc.**, 8352 Clairmont Mesa Blvd., San Diego, Calif. 92111, (619) 576-9500.

Circle 407



**Laser printer outputs 8 ppm**

- 512K bytes of memory
- Six built-in fonts
- Memory boards

The Hewlett-Packard LaserJet Series II laser printer produces 8 ppm. It comes resident with 512K bytes of memory for desktop publishing, word processing and spreadsheet printing. Features include two font-cartridge slots, a 200-sheet input bin and a 16-character front-control-panel display. Memory boards are available in 1M-, 2M- and 4M-byte configurations. The unit offers six built-in fonts and RS232C and Centronics interfaces. Up to 32 fonts can be downloaded. \$2,495. **Hewlett-Packard Co.**, 1820 Embarcadero Road, Palo Alto, Calif. 94303, phone local sales office.

Circle 409

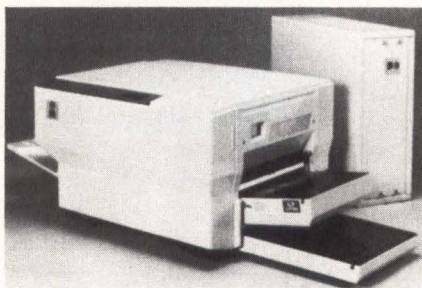

**Device combines printer, plotter**

- Nonimpact unit
- 2,000-sheet capacity
- Proprietary controller

The BGL nonimpact printing/plotting system utilizes a proprietary graphics controller and an electro-photographic engine. It features a 2,000-sheet capacity and Tektronix 4010 and 4014 emulation. The unit supports vector draw, alpha notation, point plot and incremental plot. It produces A-sized and B-sized copies. Four engines are available. \$17,900. **BGL Technology Corp.**, 438 Constitutional Ave., Camarillo, Calif. 93010, (805) 987-7305.

Circle 408

**Laser printer produces 15 ppm**

- 300 dpi
- Bit-map controller
- 21 fonts

Generating 15 ppm, the 1500 laser printer provides a 300-dpi resolution and 21 standard fonts. The unit features a dual page buffer with 3.5M bytes of memory that permits the controller to store the image being printed while creating a second bit-map for the next page. It emulates Tektronix 4014 graphics with four font sizes. Interfaces include an RS232C and a proprietary parallel. \$11,990. **Talaris Systems Inc.**, 5160 Carroll Canyon Road., P.O. Box 261580, San Diego, Calif. 92126, (619) 587-0787.

Circle 411

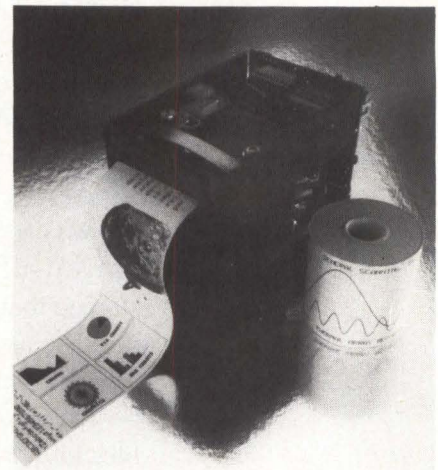

**Two-inch printer suits OEMs**

- 200 by 800 dpi
- Proprietary software
- Programmable speeds

A thermal array printer, the 2-inch AR-41, aimed at OEMs, furnishes a resolution of 200 by 800 dpi. Proprietary software provides over 13 functions. Features include automatic paper feed, programmable speeds and a Centronics interface. The device suits graphics, text, bar codes and histograms. \$420. **General Scanning Inc.**, 500 Arsenal St., P.O. Box 307, Watertown, Mass. 02272, (617) 924-1010.

Circle 412

**Dot matrix printers offer seven colors**

- 24-pin, 18-pin units
- 250, 360 cps
- 256K-byte buffer

The P2424C and P2418C are 24-pin and 18-pin dot-matrix printers, respectively. The first unit runs at 360 cps in draft mode, 180 cps in correspondence mode and 120 cps in letter-quality mode; the second device prints 250 cps in draft mode and 125 cps in letter-quality mode. Features include a 4K-byte buffer, expandable to 256K bytes, multiple font cartridges and Epson compatibility. Both printers perform seven-color printing. \$1,295, P2418C; \$1,395, P2424C. **Alps America**, 3553 N. First St., San Jose, Calif. 95134, (408) 946-6000.

Circle 410

# "It's easy looking at you, kid."



This is the screen that dreams are made of—the ADDS 2020. Its unique 70Hz refresh display gives a stunning flicker-free performance. Along with a presentation so brilliant your operators will be happy to work with it all day.

And you'll appreciate our supporting cast of bigger-than-life characters. Presented on a 14" flat green, amber or white screen, our easy-to-look-at double wide and double high/wide characters can be viewed in your choice of 80 or 132 column format. With operator selectable settings for brightness and contrast.

### Brains and beauty.

But more than just a terminal that's great to look at, the ADDS 2020 gives you brains behind the beauty. Our exclusive HelpNotes<sup>SM</sup> feature lets you program assistance messages directly into the terminal. So you

The person pictured above is a celebrity look-alike. The estate has not authorized or approved the use of look-alikes.

can actually use our hardware to simplify your software.

The 2020 also gives you intelligent desk accessories like a clock, alarm, calendar and a calculator that can work directly with your current application.

Screen test an ADDS 2020 today. It could be the beginning of a beautiful relationship. For more information on the 2020 or our entry-level 1010, the first terminal in its class to offer a built-in parallel printer port, call 1-800-231-5445. In N.Y. 516-231-5400. Ask for Displays Marketing.

**ADDS**

Applied Digital Data Systems Inc.  
A Subsidiary of NCR Corporation

100 Marcus Blvd., Hauppauge, NY 11788



CIRCLE NO. 65 ON INQUIRY CARD

Introducing  
multi-channel  
communications  
boards 400%  
faster than  
what you're  
probably using  
now.

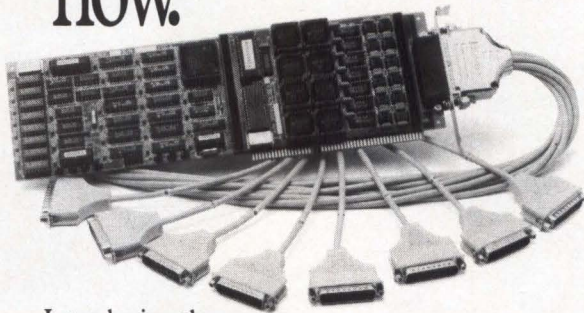

Introducing the DIGIBOARD COM/Xi Series front-end processor. Intelligent multi-channel communications boards 400% faster than the industry standard.

Like our popular COM/X Series, they provide users of PC/XT/AT-compatible computers with four or eight individually addressable serial ports. But with the new COM/Xi series we've added:

- an 80188 co-processor operating at 10 MHz
- 256K of dual-ported RAM + 16K of ROM, all accessible to user/ programmers for application and security software development
- a modular design that allows us to custom-tailor I/O to individual customer requirements.

On-board intelligence means more speed for multi-user operating systems and multi-channel data collection and dissemination.

And makes the new DIGIBOARD COM/Xi Series a more intelligent choice for you.

**DigiBoard**  
Plugging you into Tomorrow.

Call 1-800-344-4273. In Minnesota, (612) 922-8055.

CIRCLE NO. 66 ON INQUIRY CARD

## NEW PRODUCTS DATACOM

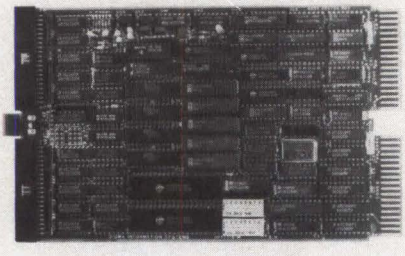

### Multiplexer furnishes DEC compatibility

- Eight lines
- 256-character buffer
- 38.4K baud rate

The SCD-DHV11/8 asynchronous multiplexer is compatible with DEC operating systems and diagnostics. It offers eight lines with EIA RS232C and RS422 operation. A 256-character buffer for received characters and DMA is provided. The unit supplies baud rates to 38.4K. Each communication line is independently programmable and includes switch-selectable device addresses. \$792. **Sigma Information Systems**, 3401 E. La Palma Ave., Anaheim, Calif. 92806, (714) 630-6553.

Circle 413

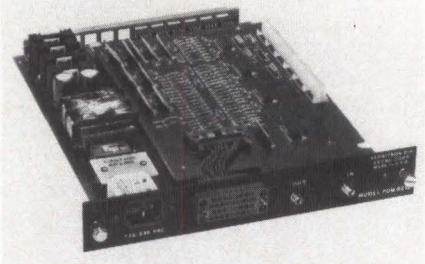

### Communications link uses fiber optics

- V.35 compatible
- Up to 76.8K bps
- Full duplex

A single-channel, fiber-optic communications link, the FOM 9218 transfers data over a 2-km topology. It is compatible with V.35 interfaces with up to 76.8K-bps operation in synchronous or asynchronous mode. Two full-duplex units can be configured as a modem link or an interface extender. The device supplies fully transparent data, clock and control signals. \$1,328. **Versitron Inc.**, 6310 Chillum Place, N.W., Washington, D.C. 20011, (202) 722-8600.

Circle 414

# “Frankly, my dear, you need a flicker-free screen.”



Now tired-eye problems are gone with the wind, with the DEC-compatible ADDS 3220. The 3220's unique 70Hz refresh display gives one of the most brilliant flicker-free screen presentations ever.

And you'll appreciate our double features, too. Like our easy-to-read double high and double high/wide characters, viewed in a choice of 80 or 132 column format. All presented on a 14" flat green, amber or white screen. With user selectable settings for brightness and contrast.

### A truly sophisticated performance.

But more than just great looks, the ADDS 3220 turns in a great performance, too. Our DEC-style keyboard enhances the performance of your software. With value-added features like 22 fully programmable function keys and 256 bytes of non-volatile memory that help you

distinguish your product from the competition.

Naturally the ADDS 3220 is fully compatible with the DEC VT220, VT100, VT52, and ANSI X3.64. What's more, it won Digital Review's 1987 "Best Alphanumeric Terminal of the Year" award.

Preview one today. Let us show you that when it comes to award-winning performances ADDS gives a darn. For more information, call 1-800-231-5445. In N.Y. 516-231-5400. Ask for Displays Marketing.

**ADDS**  
Applied Digital Data Systems Inc.  
A Subsidiary of NCR Corporation

100 Marcus Blvd., Hauppauge, NY 11788



The person pictured above is a celebrity look-alike. The estate has not authorized or approved the use of look-alikes.

CIRCLE NO. 86 ON INQUIRY CARD

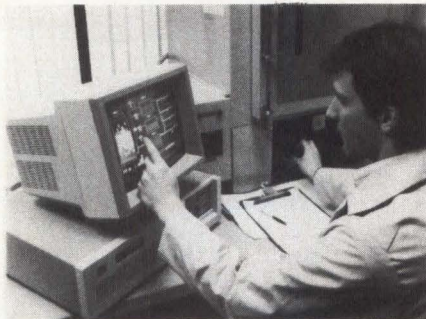

### Monitor displays up to 64 colors

- 0.31-mm dot pitch
- 14-inch unit
- 800 by 560 pixels

A multisynchronous monitor, Multi-synch Touch displays up to 64 colors on a 14-inch screen. The unit incorporates a 0.31-mm dot pitch and an 800-by-560-pixel resolution. It works with

graphics boards having scanning frequencies from 15.75 kHz to 35 kHz. \$1,795, OEM pricing available. **MicroTouch Systems Inc.**, 10 State St., Woburn, Mass. 01801, (617) 935-0080. **Circle 415**

## 2.5 Gigabytes



### With 9-Track Industry Standard I/O

Utilizing true read-after-write coupled with very powerful error correction, GIGASTORE™ gives you an unsurpassed error rate of 1 in  $10^{23}$  bits. In addition, you get a high speed search capability not available in most 9 track drives and the convenience of a T-120 VHS cartridge. IBM PC, DEC and other interfaces available.

Call Digi-Data, an organization with a 25 year history of manufacturing quality tape drives at (301) 498-0200.

™GIGASTORE is a trademark of Digi-Data Corporation.

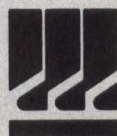

**DIGI-DATA CORPORATION**  
8580 Dorsey Run Road  
Jessup, MD 20794-9990  
(301) 498-0200  
Telex 87-580

• ... First In Value

In Europe contact: Digi-Data Ltd. • Unit 4 • Kings Grove • Maidenhead, Berkshire  
England SL6 4DP • Telephone No. 0628 29555/6 • Telex 847720

**CIRCLE NO. 67 ON INQUIRY CARD**



### Graphics terminal uses MC68020 processor

- 4.5M bytes of memory
- 1,280 by 1,024 pixels
- Pan and zoom

An interactive imaging and graphics display terminal, the 4660 is designed around a Motorola MC68020 micro-processor and a 6881 floating-point co-processor. It offers up to 4.5M bytes of memory, independent pan and zoom and two look-up tables. Resolution is 1,280 by 1,024 pixels. The unit supports up to nine 4-bit refresh memory groups. Features include a built-in video multiplexer and a 4M-pixel-per-second raster bus. \$18,700. **Ramtek Corp.**, 2211 Lawson Lane, Santa Clara, Calif. 95052-8024, (408) 988-2211.

**Circle 416**

### Color terminal targets CAD applications

- 512K bytes of memory
- 19-inch screen
- 640 by 480 pixels

An intelligent, color graphics terminal, the 4209 targets low-end CAD and technical data analysis applications. The unit displays 640 by 480 pixels on a 19-inch screen and supplies 512K bytes of memory plus DEC VT100 compatibility. Up to 16 graphics colors and eight alphanumeric colors are selectable from a 4,096-color palette. An upgrade kit is available. \$6,995. **Tektronix Inc.**, P.O. Box 500, Beaverton, Ore. 97077, (503) 644-0161.

**Circle 417**

# Unleashing a powerful new species of Firebreather. The mini supercomputers from Gould.



There's a vast world of difference between the power of a super minicomputer and our new Firebreathers — the Gould NPL™ family of mini supercomputers. It's a whole new category of compatible Gould computers that bridges the gap between giant supercomputers on the one hand and superminis on the other.

The Gould NPL family offers you the power and speed of supercomputers at the cost of superminis, and they are every bit as easy to use. NPL, the first Firebreather in the NPL family, delivers performance equal to first generation supercomputers.

## Harness the power:

- Multiprocessor parallel architecture.
- High performance scalar and vector processing.
- Real memory expandable to 4 billion bytes.
- Industry standard I/O subsystems.
- Continuous throughput 5 times faster than any supermini.
- Gould's proven UNIX®-based operating system, UTX/32®.
- Languages that include vectorizing FORTRAN and highly optimized C compilers, plus Ada®

How you use Gould's NPL family is limited only by your imagination.

Consider this power applied to complex scientific and engineering computations, simulation, real time data acquisition and intensive program development.

If your present computer no longer has the power you really need, get in touch with the future. Get in touch with Gould.

**Gould, Inc., Information Systems  
Computer Systems Division  
6901 West Sunrise Boulevard  
Fort Lauderdale, Florida 33313  
1-800-GOULD-10, TLX 441491**

UNIX is a registered trademark of AT&T Bell Labs.  
Ada is a registered trademark of the U.S.  
Government, Ada Joint Program Office.  
NPL & UTX / 32 are trademarks of Gould, Inc.

**CIRCLE NO. 68 ON INQUIRY CARD**

 **GOULD**  
*Electronics*

# SUGAR CUBE

## SWEETEN YOUR PROFITS



### **A profitable sales call begins with a memorable product.**

This CUBE will give you an edge over other "me too" Unix™ systems.

Cubix<sup>2</sup> is a no compromise approach to Unix — designed to make a dynamic, memorable impression.

Within this perfect 11 inch cube is a 220MB formatted Winchester 60MB tape, 1.2MB floppy, a built-in UPS, math coprocessor, up to 8MB RAM, and support for 8 users.

And Cubix<sup>2</sup> conforms to the SVID standard — hundreds of Unix programs are run on Cubix.

A package with mini performance at personal computer prices from a company with 12 years of VAR/OEM support experience.

*How do we do it? Call us and we'll tell you.*

*Your prospects will remember CUBIX<sup>2</sup>.*

*Your prospects will remember YOU.*



**L/F TECHNOLOGIES, INC.**

Toll Free: 1-800-648-7977

In Nevada call: (702) 883-7611

CORPORATE OFFICES: 2800 LOCKHEED WAY, CARSON CITY, NEVADA 89701 • PHONE: (702) 883-7611 • TWX: (910) 395-6051 LFCARS

UNIX is a trademark of AT&T Bell Laboratories.

CIRCLE NO. 69 ON INQUIRY CARD



NEW PRODUCTS  
SOFTWARE

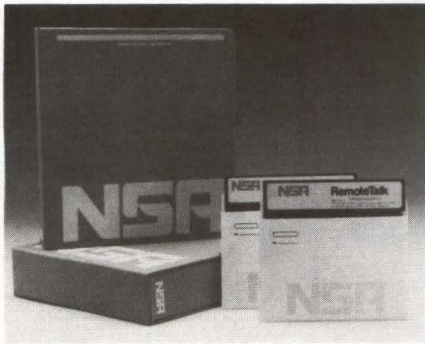

**Datacom software links personal computers**

RemoteTalk is an IBM-compatible PC-to-PC synchronous communications package with remote control and file transfer capabilities. Compatible with 18 SDLC boards, the software communicates via IBM's SDLC protocol at up to 19.2K bps. A synchronous modem is available. \$295 and higher. **Network Software Associates Inc.**, 22982 Mill Creek, Laguna Hills, Calif. 92653, (714) 768-4013.

Circle 418

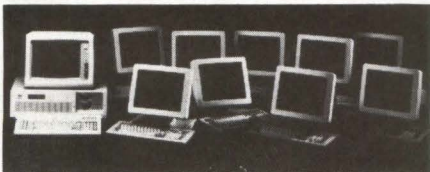

**OS supports 10 IBM PC/ATs**

An operating system for the IBM PC/AT and compatibles, Pick Version 2.0 supports up to 10 users. The package provides advanced virtual-memory architecture and relational database capabilities. It supports three parallel printer ports, streaming cartridge tape drives and rigid disk drives. \$1,295. **Pick Systems**, 1691 Browning, Irvine, Calif. 92714, (714) 261-7425.

Circle 419

**DBMS software turns PC/AT into server**

A database management system, SQLBase Version 3.1 turns IBM PC/ATs into relational database servers that can be accessed by multiple PCs running on the IBM Token-Ring Network. The software operates on NETBIOS-compatible networks. It includes a C application programming

interface. \$995, single-user version; \$1,995, multiuser version. **Gupta Technologies Inc.**, Suite 240, 1040 Marsh Road, Menlo Park, Calif. 94025, (415) 321-9500.

Circle 420

**Software runs DOS on 386-based computers**

Control/386 software runs on 80386-

based computers and supplies compatibility with 8088- and 80286-based systems. The package provides 32-bit emulation of AST's Enhanced Expanded Memory Specification and the Lotus/Intel/Microsoft Expanded Memory Specification. It allows users to run DOS applications on the 80386 CPU and can be customized. \$8.00, Quantity 5,000. **Phoenix Technologies Ltd.**, 320 Norwood Park S., Norwood, Mass. 02062, (617) 769-7020.

Circle 421

# Full-time Employment for your Laser Printer

Everyone knows printers are expensive, especially laser printers. And most of the time, your printer just sits there waiting for something to do.

**BUFFALO PRODUCTS** has unveiled the intelligent way of keeping your printers employed full-time... with the newest addition to our line of intelligent buffers, the SX model.

The Buffalo SX features 10 total input and output ports, combining both serial and parallel interfacing, giving you total flexibility to arrange your resource network.

You can have up to 7 PC's sharing 3 output devices (printers, laser printers, modems, plotters, etc.), 2 PC's sharing 8 output devices or practically any combination in between.

Some of the outstanding features include:

- 256K dynamically allocated buffer, user upgradable to 1024K.

- Daisy-chain up to 9 units to expand your network.
- Simultaneous input by up to 3 users at a time.
- Individually configured serial ports for automatic protocol/baud rate and parallel/serial conversation.
- Battery backup to store setup configuration.

We are so sure you'll like what you get in the new Buffalo SX Buffer, we are offering a No Questions Asked 45-DAY-MONEY-BACK Guarantee along with our 1-year warranty. And the best part is the price...

only \$695

**BUFFALO**

PRODUCTS

Call 1-800-654-5301  
In California, Call: (213) 493-2471  
Sales and Marketing, CSSL, Inc.

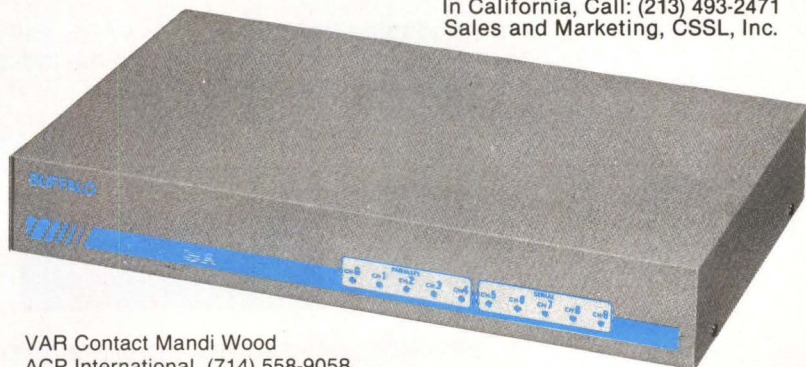

VAR Contact Mandi Wood  
ACP International, (714) 558-9058

Technical Assistance call: 1-800-345-2356 In California call: (408) 279-2356

CIRCLE NO. 70 ON INQUIRY CARD

# THE 100 USER 32-BIT 80386 BASED COMPUTER THE ENSIGN 386:100

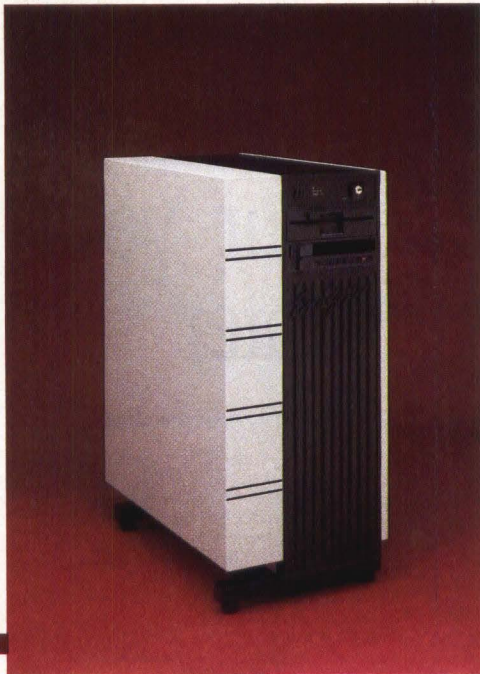

## The Computer You Will Not Outgrow!

This is the ultimate 80386 based multi-user computer you have been waiting for. At a base price not much higher than 386 PC type machines, the Ensign 386:100 can expand to be a computer that you will not outgrow.

The key to the Ensign's multi-user performance is its intelligent serial and disk controllers. Using up to four 68010 CPU's and over 1MB of buffer memory to handle serial and disk overhead, the 80386 is free to provide its full performance to as many as 100 users.

## 32-Bit Intel 80386 Processor

- 16-100 serial I/O ports
- 1-24MB memory
- 60MB streamer tape
- 25-840MB disk storage
- 1MB disk/serial I/O buffer memory
- 1-4 slave 68010 processors

## Need Software? The Ensign 386:100 can run it all.

### PC-MOS 386\*

A multi-user MS-DOS look alike, that takes advantage of the 80386's multi-user capability.

If you use multi-user systems and need low prices and high performance then give us a call. IBC is the only company that can sell you a low cost 80386 computer that will last you for life.

### XENIX 386\*

The most popular commercial version of UNIX\*. AT&T System V compatible.

### THEOS 386\*

The latest version of THEOS (OASIS) for the 80386.

### PICK\*\*

A popular user friendly operating system now available for the 80386.

VARS, call IBC now to find the best dealer discounts in the industry. If you don't, your competition will.



21621 NORDHOFF STREET, CHATSWORTH, CA 91311  
TELEX: 215349 TELEPHONE: (818) 882-9007

Nationwide on-site service available from  
REI/Recognition Equipment, Inc.  
(800) 225-8515

CIRCLE NO. 71 ON INQUIRY CARD

\* PC-MOS 386 is a trademark of The Software Link  
XENIX 386 is a trademark of Microsoft  
UNIX is a trademark of Bell Laboratories  
THEOS 386 is a trademark of THEOS Software Corp.  
\*\* PICK is a trademark of PICK Systems and is only available from IBC Technologies (714) 261-5504 — not affiliated with IBC/Integrated Business Computers

NEW PRODUCTS  
SUBASSEMBLIES

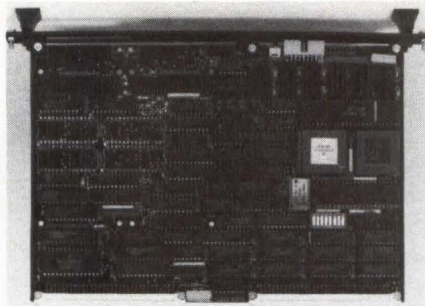

**VMEbus adapter supports 128 devices**

The HPS-6945 is a VMEbus-compatible host adapter for Unplug, a proprietary data communications subsystem. It allows support of up to 128 peripherals at distances to 1,000 feet away from the host computer, without use of repeaters. The device features a MC68010 microprocessor running at 12.5 MHz and 512K bytes of RAM. \$1,770.

Systech Corp., 6465 Nancy Ridge Drive, San Diego, Calif. 92121, (619) 453-8970. **Circle 424**

**KEEP YOUR SUBSCRIPTION**

To keep your free subscription to Mini-Micro Systems, turn back to the requalification card attached to the front cover. Please fill it out and return it to us right away.

**SBC features modular I/O functions**

- Two RS232C ports
- MC68000 processor
- 2-, 4-channel DMA

The OB68K/VSBC1 single-board computer uses a Motorola MC68000 processor and features over 20 modular I/O functions. It supplies two asynchronous RS232C ports and two RS422 ports and two- or four-channel DMA. A bus-interrupt generator allows the unit to function as an intelligent slave. Features include 512K bytes of RAM. A 68010 processor is optional. \$1,036. **Omnibyte Corp.**, 245 W. Roosevelt Road West Chicago, Ill. 60185-3790, (312) 231-6880.

**Circle 422**

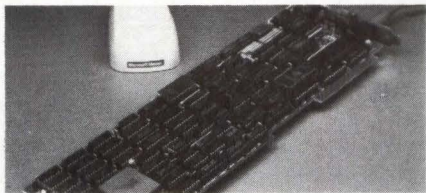

**Graphics controller works with IBM PC**

- 10,000 cps
- 1,280 by 960 pixels
- 82786 coprocessor

A monochrome graphics controller for the IBM PC/XT and PC/AT, Desktop 1280 supplies a bit-block transfer rate of 10,000 cps and a line drawing rate of 1.25 million pixels per second with a resolution of 1,280 by 960 pixels. The Intel 82786-based device supports a 64-Hz non-interlaced refresh rate and the IBM Color Graphics Adapter. It can display two pages of text simultaneously. Features include pan and zoom. \$1,295. **Verticom Inc.**, 525 Weddell Drive, Sunnyvale, Calif. 94089-2114, (408) 747-1222.

**Circle 423**

# De·pot Di·rect<sup>SM</sup>

(dē' pō di rekt'), *n.*

1. reliable TRW quality.
2. fast turnaround.
3. single source repairs.
4. toll free: 1-800-922-0897.

Now depot repair takes on a whole new meaning! Depot Direct<sup>SM</sup> from TRW is the preferred nationwide source of reliable, quality repair for microcomputer equipment and subassemblies.

Fast turnaround and competitive prices are just a toll-free phone call away. And you'll benefit from them often, because Depot Direct repairs a wide selection of popular brands. Included: Altos. IBM. TeleVideo. Hazeltine. Okidata. Wyse. Taxan. AT&T. Esprit. Multitech. Tandon. MPI. Sony. Rodime. Shugart. Quantum. Plus many others!

Our professional, factory-trained technicians expertly repair subassemblies, disk drives, printers, circuit boards, print heads, computers, terminals and peripherals. And all repairs carry a 90-day TRW Warranty.

See just how many advantages TRW's consistent quality and fast turnaround can add to

your service capability. Call toll free today for your free Depot Direct repair catalog and price list. Call 1-800-922-0897. (In New Jersey 201-575-7110 Ext. 4231.)

Depot Direct: TRW gives depot repair a new definition.

**TRW Customer Service**

15 Law Drive  
P.O. Box 2078  
Fairfield, NJ 07006



TRW, Inc. 1987. TRW is the name and mark of TRW Inc. Depot Direct is a service mark of TRW Inc.



# All-In-One AMT Office Printer™

### Fonts and Print Modes

The AMT Office Printer can store up to eight resident fonts. You can print these fonts in Letter, Memo, or Draft mode. Letter mode produces true letter-quality characters at 45 cps. Memo mode produces characters that are near-letter-quality at 100 cps. Draft mode produces draft-quality characters at 250 cps. Here are some examples:

Courier 72, one of the most popular business typefaces, prints 10 characters to the inch.

Letter Gothic 12, another widely-used typeface, prints 12 characters to the inch.

Gothic 12, a font that is perfect for printing spreadsheets, prints 12.5 characters per inch.

Trend FS, a proportionally-spaced typeface, comes in handy when typing formal documentation.

Scientific 10:

$$\frac{1}{H} = \sum_{i=1}^n dx \left( \frac{\sin x^2}{\cot x^2} \right)$$
$$\sum_{k=1}^N \frac{1}{k} = \sum_{k=1}^N \frac{1}{k} = \sum_{k=1}^N \frac{1}{k} = \sum_{k=1}^N \frac{1}{k}$$

### Software Compatibility

Since the AMT Office Printer can emulate a Diablo 630 or C-150, Qume Sprint 11, IBM Color Printer, or Epson printer, the AMT works with virtually any off-the-shelf software package.

### Special Effects

The AMT Office Printer can perform many special printing functions, like those shown below:

- Variable slant
  - 10-degrees
  - 20-degrees
  - 30-degrees
- Expanded
  - Vertical
  - Horizontal
  - Or both
- Bold, shadow and underscored
- Automatic text formatting
  - Centering
  - Justification

### Graphics

Finally, the AMT Office Printer can print full-color graphics with variable dot resolutions up to 240V x 480H dots per inch.



### Printer Compatibility

The AMT Office Printer can contain multiple resident emulations. This feature lets you turn the AMT Office Printer into a variety of other popular printers. For example, if you're using a program that supports only the Epson JX-80 printer and not AMT, just press a single button and the AMT is instantly compatible.

### Color Graphics on the AMT Office Printer

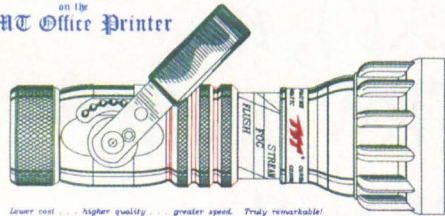

Lower cost... higher quality... greater speed. Truly remarkable!

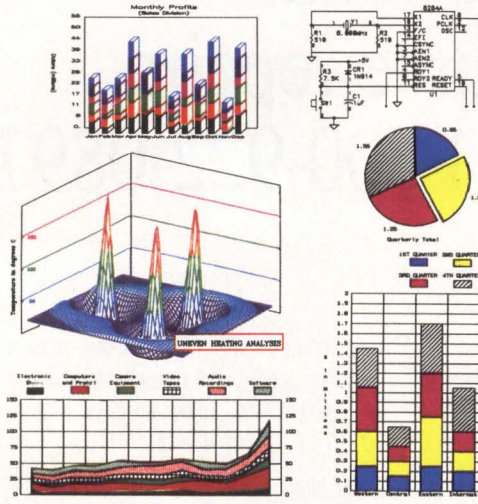

1157 Tourmaline Drive, Newbury Park, CA 91320, U.S.A.  
Telephone USA (805) 499-8741 FAX USA (805) 499-1147 Telex 206495

New

# The AMT Office Printer™ PLUS

Tired of juggling three or more separate devices to meet your printing needs? Confused about which technology—daisywheel, dot-matrix, plotter, ink-jet, thermal or laser—is right for you? Worried about software/printer compatibility?

Introducing the AMT Office Printer PLUS, an all-in-one printing solution that does the job of all these devices with superb print quality, speed, and the ability to mix text with multicolor high-resolution graphics.

How can one printer do so much? With an ingenious print mechanism, unrivaled font, graphic and color flexibility, multiple co-resident emulations, plus widespread hardware and software compatibility.

The AMT Office Printer PLUS is applications-oriented. For word processing, there is better-than-letter and near-letter-quality text, a font library with both fixed and proportionally-spaced fonts, variable pitches, language support, IBM graphic symbols, scientific and technical character sets, and built-in features that italicize, color, bold, shadow, super/subscript, underscore, expand, center, and justify text. For data processing, there is high-speed, draft-quality text with up to 264 characters per line. For business graphics, CAD/CAM/CAE plots, and other precision graphic applications, there are full-color graphic modes providing resolutions up to 240V x 480H dots per inch. And for technical applications, there is custom font generation, font download, plotter emulation, and many other printing utilities.

Most importantly, the AMT Office Printer is fully compatible with software that drives the Diablo 630™, Diablo C-150 Ink-Jet Printer™, IBM Model 5182 Color Printer™, or Epson JX-80™. So just plug the printer into your computer's serial or parallel port, load your favorite software, and begin printing.

Isn't it about time to solve all your printing problems? The all-in-one AMT Office Printer PLUS!

CIRCLE NO. 90 ON INQUIRY CARD

1157 Tourmaline Drive  
Newbury Park, CA 91320 (805) 499-8741  
European sales office UK (0) 7356-71464

Advanced Matrix Technology, Inc.



For applications that don't need color  
AMT also offers black-only mode

## HOW TO OPTIMIZE YOUR LASER PRINTER

Edward Teja, Contributing Editor

Three classes of programs can make your personal computer and laser printer do more, and do it better. In selecting the programs, though, understanding their differences is critical, because vendors won't enlighten you unless you ask questions.

In the first class are the printer-control programs that let you specify fonts and control page formats independent of your application program. Printer-control programs embrace all of the enhanced printing utilities, such as those that allow users to change fonts, highlight (with semi-gray scale), draw lines and boxes and, possibly, merge graphics and text.

The second class of programs lets you embed format commands that are executed as your documents are printed. And the third class are what many think of as WYSIWYG, or "what you see is what you get," page-composition packages.

The second class provides powerful software capabilities, if you have the patience to master them. Examples of this type of program include Polaris Software's PrintMerge and Ram-resident PrintMerge. Each offers interesting benefits to users but, for reasons that will become clear, they are examined separately.

PrintMerge is a natural publishing environment for those who use Micropro International Corp.'s WordStar for word processing. The command formats and logic are similar to those used in that popular word processing package. In fact, PrintMerge is recommended for use only with WordStar. At any rate, the more you use the package, the more you'll like the power and consistency it provides.

A key strength of PrintMerge lies in its powerful formatting tools. Handling the typesetting of tables, for instance, is usually difficult. Many programs require you to collapse data

(remove all spaces) and separate data fields with commas. Not so with the versatile PrintMerge: here, one simple instruction defines the characteristics of the input data; another defines the format of the output. Thus, you can accept data from a spreadsheet, word processing package or other source and use it without retying.

A major difference between PrintMerge and similar programs is that this package controls the printing process. It provides a proportional-spacing algorithm that produces attractive output, and with every format difficulty encountered, the solution is evident—once you look at the commands in the text.

PrintMerge isn't the easiest package to use, but its logic and consistency make it understandable. And it is powerful. Its one shortcoming lies in its inability to use graphics images generated by popular bit-image paint programs.

On the other hand, Ram-resident PrintMerge lets users control the printer, change type fonts, draw lines and boxes and, what is of particular importance, merge graphic images with text.

Now, logic would dictate that a package called Ram-resident PrintMerge would be a faster version (not having to load fonts from disk) of the PrintMerge program. This is not the case. Ram-resident PrintMerge is a printer-control utility (a class 1 program) that has similarities to the class 2 PrintMerge package, but is substantially different both in how it works, and what it is trying to do.

We ran into problems making this product work, and most of those problems came from the fact that we expected it to be an extension or superset of PrintMerge. Furthermore, the documentation was of little help here. Polaris president Jack Leach admitted the shortcomings of the documentation and told us that his compa-

ny is already at work on new, clearer manuals. And he acknowledges the difficulties in learning the software. "But if a person sticks to it," he says, "they'll find that the effort is worth it." We agree. What is practically unforgivable is that both packages are called PrintMerge, leading to the understandable conclusion that, originally, Ram-resident PrintMerge was intended to be a true superset of PrintMerge.

A second caveat with this program is that it is intended for word processing packages, such as Ashton-Tate's Framework, that don't provide for managing more than one printer font. Using WordStar as the text-generation program begs for trouble. Leach explained that sellers are supposed to ask potential buyers what word processing package they intend to use and steer WordStar users away from Ram-resident PrintMerge.

Along with Ram-resident PrintMerge is a utility called Crunch (\$49.95) that helps the Hewlett-Packard Co. Laserjet printer cope with the large files that graphics require. The utility shrinks the size of the file by eliminating unnecessary graphics commands. This helps the throughput—and you'll need all the help you can get. A reasonably complex page (containing a few tables) can take 8.5 minutes to print, and this comes from what supposedly is an 8-ppm printer, when it's confined to text.

In the end, both packages are worth their price. Impatience with PrintMerge's shortcomings quickly gives way to amazement at its power. But with either package expect to spend a full day just learning how to use it.

---

PrintMerge and Ram-resident PrintMerge, Polaris Software, 613 W. Valley Parkway, Suite 323, Escondido, Calif. 92025, (619) 743-7800. \$124 and \$149 respectively.

---



Some  
of the best  
ideas in LaPine  
Spartan™ drives  
are the parts  
we leave  
out.

Engineering a high-performance 3.5-inch Winchester drive for cost-sensitive applications means knowing how to streamline without cutting corners.

**More for less.** LaPine™ Spartan drives deliver high performance with substantially fewer components. By integrating components with flex circuitry, eliminating connectors, and utilizing a two-layer PC board, LaPine has effectively simplified the drive while increasing inherent reliability.

**Advanced alternatives.** LaPine applies its advanced-engineering approach to its entire family of 3.5-inch Winchesters. LaPine Titan™ 20, 30 RLL, and 40 SCSI drives employ advanced stepper-motor technology to meet today's performance demands. Because stepper motors are fast, reliable, and economical. And Titan's unique head-suspension system is ideal for physically demanding applications.

To find out more, contact LaPine Technology today.

LaPine 3.5-inch Winchester Drives.

The Idea. Refined.

**LAPINE**  
TECHNOLOGY

182 Topaz Street  
Milpitas, California 95035  
408/262-7077

In association with  
Prudential-Bache and Kyocera.  
©1987 LaPine Technology Corporation



CIRCLE NO. 75 ON INQUIRY CARD

# Mini-Micro Systems

## Spring Peripherals Handbook

### INTRODUCTION

#### Product reference tables: terminals and printers . . . . . 149

Precipitous price erosion continues in the terminals market; dot-matrix printers approach commodity status; and impact line printers remain heavy-duty workhorses, despite pressure from laser printers.

### PRODUCT GUIDES

#### Alphanumeric display terminals . . . . . 151

#### Dot-matrix character printers . . . . . 161

#### Impact line printers . . . . . 169

### HOW TO USE THE PRODUCT GUIDES

This edition of the *Peripherals Handbook* contains three *Product Guides* beginning on Page 151. Each *Product Guide* contains price and specification information, arranged alphabetically by company name. These tables are based on mail- and telephone-survey information.

Accompanying each vendor's name is the mailing address, telephone number and a circle number with which you may request additional information using the reader-service card located at the end of the issue.

#### To check product prices or specifications:

- Find the appropriate product table
- Find the alphabetically listed vendor.

#### To select a product:

- Turn to the appropriate product table
- Study the product offerings
- Use the address information found with the company name to contact the vendor.

To comment on the *Peripherals Handbook*, or to suggest future product coverage, contact the Chief Editor, *Mini-Micro Systems, Peripherals Handbook*, Cahners Publishing Co., 275 Washington St., Newton, Mass. 02158-1630

Cahners Publishing Company • A Division of Reed Publishing USA • Specialized Business Magazines for Building and Construction • Computer/Technology • Electronics • Food/Packaging • Manufacturing Industries • Medical, Design & Publishing MINI-MICRO SYSTEMS® (ISSN 0364-9342) is published monthly with additional issues in May and November by Cahners Publishing Company, A Division of Reed Publishing USA, 275 Washington St., Newton, MA 02158. William M. Platt, President; Terrence M. McDermott, Executive Vice President; Jerry D. Neth, Vice President of Publishing Operations; J.J. Walsh, Financial Vice President/Magazine Division; Thomas J. Dellamaria, Vice President Production and Manufacturing; Frank Sibley, Group Vice President. Copyright 1987 by Reed Publishing USA, a division of Reed Holdings Inc., Saul Goldweitz, Chairman; Ronald G. Segel, President and Chief Executive Officer, Robert L. Krakoff, Executive Vice President. Circulation records are maintained at Cahners Publishing Co., 270 St. Paul St., Denver, CO 80206. Second class postage paid at Denver, CO 80206 and additional mailing offices. Postmaster: Send address changes to MINI-MICRO SYSTEMS®, 270 St. Paul St., Denver, CO 80206. MINI-MICRO SYSTEMS® is circulated without charge by name and title to U.S.- and Western European-based corporate and technical management, systems engineers and other personnel who meet qualification procedures. Available to others at the rate of \$65 per year in the United States; \$80 in Canada and Mexico; \$105 surface mail in all other countries; air mail surcharge, \$45 (14 issues). Special HANDBOOK issues, \$15. Single issues, \$6 in the United States; \$8 in Canada and Mexico; \$10 in all other countries.

© 1987 by Cahners Publishing Company, Division of Reed Publishing USA. All rights reserved.

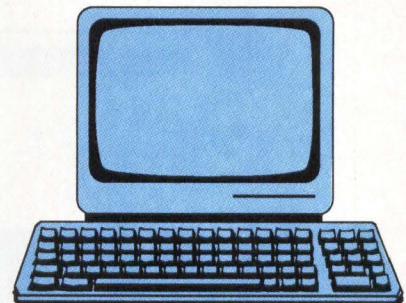

p. 151 . . . . . Prices fall

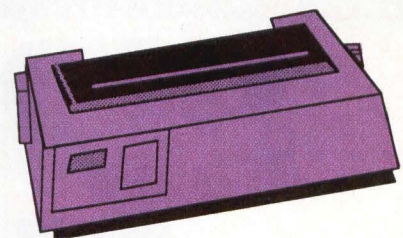

p. 161 . . . . . Commodity status

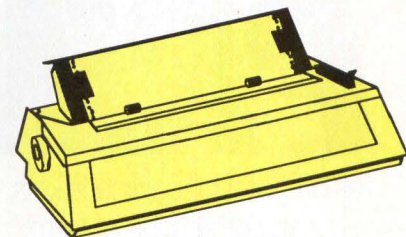

p. 169 . . . . . Remaining strong

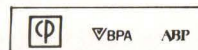

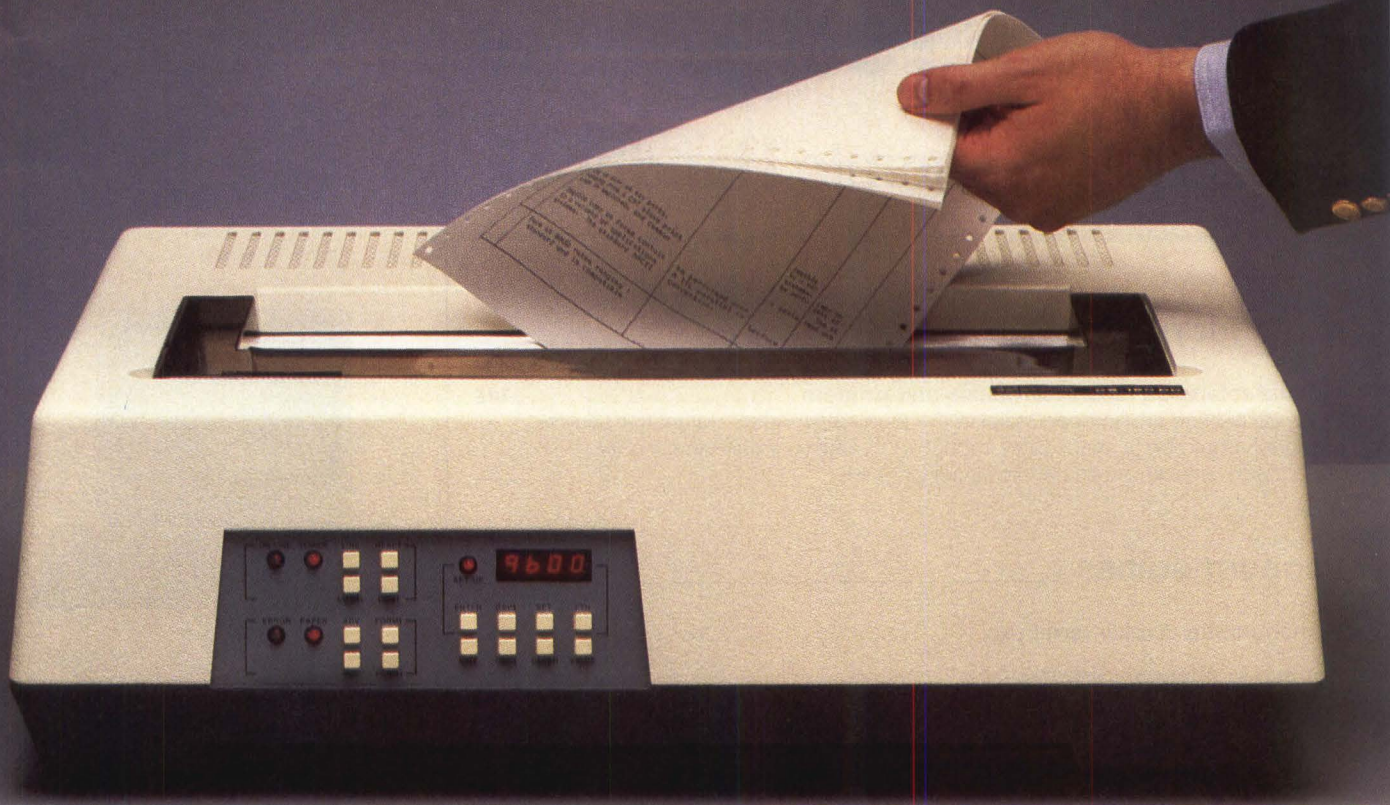

# RIP OFF THIS PRINTER.

Rip off hotel bills, airline tickets, invoices or any other type of form, up to six copies thick. Datasouth Demand Document printers put them out day and night, and let you rip them off without losing the next form.

Datasouth Demand Document printers feature bidirectional dot matrix printing at 180 cps. You can print to within 1/2 inch of the tear-off bar, without affecting the next form. The push-button front panel and LED readout make

our printers exceptionally easy to use.

There's a Datasouth Demand Document printer for almost any communications environment. The DS 180 DD has standard Serial and Centronics-type parallel interfaces. The TX 5180 DD emulates the IBM 5256, 5224 and 5225 printers in System 34/36/38 environments. And the CX 3180 DD emulates the IBM 3287 in 3270 environments.

No matter what kind of form you're printing, there's a Datasouth printer that could be doing it better. So call us at 1-800-222-4528, and ask about our Demand Document printers.

When you consider all the money-saving advantages, it's really quite a steal.



**Datasouth**  
AMERICA'S HIGH PERFORMANCE  
PRINTER COMPANY

P.O. Box 240947, Charlotte, NC 28224, (704) 523-8500, Tlx: 6843018, DASO UJV SALES: 1-800-222-4528, SERVICE: 1-800-438-5050; West Coast Office: 415-940-9828.

IBM is a registered trademark of International Business Machines Corporation

**CIRCLE NO. 76 ON INQUIRY CARD**



# PRODUCT REFERENCE TABLES: TERMINALS AND PRINTERS

Precipitous price erosion continues in the terminals market; dot-matrix printers approach commodity status; and impact line printers remain heavy-duty workhorses, despite pressure from laser printers

The tables in *Mini-Micro Systems'* biannual *Peripherals Handbook* are structured as general guidelines for volume buyers making critical purchasing decisions. We have mailed over 350 questionnaires and have made over 100 follow-up calls to provide you with as complete a listing as possible.

The product table covering alphanumeric display terminals lists 110 devices from 45 manufacturers. Terminal manufacturers have been plagued by precipitous price erosion over the last few years, which has led to a minor shakeout. But industry analysts predict a sales upswing beginning late this year. Their optimism stems from the increased popularity of multiuser microcomputers, which can accommodate more and more terminals, and the growth in terminal-intensive applications, such as on-line transaction processing and distributed data processing.

For example, a recent report by Frost & Sullivan Inc., New York, predicts that the overall terminals market will climb from 3.6 million units shipped in 1986 to more than 4.3 million in 1987. The market research company expects the number to top 8 million by 1992. Measured in constant 1986 dollars, that would represent a jump from \$12.6 billion in 1986 to over \$24 billion in 1992.

IBM Corp.'s 3270 family of terminals accounts for over 25 percent of the total installed base in the United States. Among intelligent-terminal manufacturers, IBM and Digital Equipment Corp. hold commanding shares, 18 percent and 16 percent, respectively, according to Frost & Sullivan.

One of the more important technological advances in the terminals market is the development of denser, often proprietary, chips that reduce the number of discrete logic compo-

nents. This parts reduction in turn contributes to greater reliability.

Another trend revolves about single terminals that address all three major terminal categories: ASCII, ANSI and PC terminals. PC terminals do not have full PC compute power; rather, they are designed specifically for attachment to multiuser PCs.

Dot-matrix printers, our second product category, face fierce competition from laser printers (MMS, April, Page 83). However, manufacturers are making technological improvements to protect market share in data logging, general-purpose graphics and near-letter-quality correspondence (MMS, December 1986, Page 26). Improvements include a shift to 24-pin print-heads, faster speeds, more emulation modes, wider carriages and inexpensive add-ins for color output. Dot-matrix technologies such as ink-jet and thermal transfer lead the way to better color output (MMS, January, Page 85.) Fueling the move toward color is an increasing availability of software that takes advantage of the color capabilities of matrix printers.

CAP International Inc., a market research company in Marshfield, Mass., pegs shipments of impact matrix printers at 3.5 million units in 1985, 4.5 million in 1988 and 4.8 million in 1991. In dollars, that's \$2.3 billion in 1985, \$3.4 billion in 1988 and \$2.9 billion in 1991. Price reductions account for the predicted drop in revenues from 1988 to 1991.

Impact line printers are also feeling the competitive heat of laser printers. Impact line printers seem destined for moderate growth at best. Nevertheless, *Mini-Micro Systems* rounded up 15 manufacturers of these high-volume, heavy-duty-cycle workhorses. They represent more than 40 products from which to choose.

— David Simpson

# Personal lasers, like chairs, weren't built to be shared.

## Our new laser takes on as many as 10, comfortably.

Dataproducts' new LZR 1230 is the first laser printer in its class that's enough machine to go around.

At 12 copies a minute, for instance, it has the speed to take on up to ten office overachievers at once.

Plus it has the stamina to keep up that pace to the tune of 10,000 pages a month. Over twice the duty cycle of the LaserJet.

While personal lasers are ready to quit after the first 100,000 pages, ours is just getting started. On its way to 600,000.

The LZR 1230

also has three user ports (one parallel, two serial), standard. So three different computer systems can share it at the same time. No more cable switching.

And when it comes to handling paper, nothing in its class can touch the LZR 1230. It can automatically feed up to 750 pages—of various sizes—plus 100 envelopes. Without being tended. Takes labels and transparencies, too.

What's more, it emulates the Diablo 630, Epson FX-80 and HP LaserJet Plus. So you don't have to throw away your old software.

All of which makes it the perfect printer for sharing. Call us. And stop playing musical chairs.



LZR 1230



**Dataproducts® laser printers**

**1 (800) 556-1234, x 581**

IN CA, 1 (800) 441-2345, x 581  
6200 CANOGA AVENUE WOODLAND HILLS, CA 91365

CIRCLE NO. 77 ON INQUIRY CARD

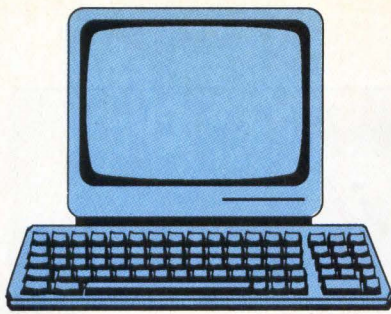

# ALPHANUMERIC DISPLAY TERMINALS

| Company                                                  | Model | Terminal type        | Display size, color<br>(diagonal inches) | Screen format<br>(col. x-line) | Interfaces                  | Emulations                                                 | Price \$<br>(quantity)    | Notes, features                                                               |
|----------------------------------------------------------|-------|----------------------|------------------------------------------|--------------------------------|-----------------------------|------------------------------------------------------------|---------------------------|-------------------------------------------------------------------------------|
| <b>3M CO. (TELETERMINAL PRODUCTS)</b>                    |       |                      |                                          |                                |                             |                                                            |                           |                                                                               |
| 311 Turquoise St., Milpitas, CA 95035, (408) 943-1970    |       |                      |                                          |                                |                             |                                                            |                           |                                                                               |
| Whisper Screen                                           | 1923  | intelligent          | 9-inch, monochrome                       | 80x25                          | RS232C                      | DEC VT52, VT100                                            |                           | 12 programmable function keys, built-in modem                                 |
| Whisper Screen                                           | 1924  | intelligent          | 9-inch, monochrome                       | 80x25                          | RS232C                      | DEC VT52, VT100                                            |                           | 12 programmable function keys, built-in modem                                 |
| <b>ADAC CORP.</b>                                        |       |                      |                                          |                                |                             |                                                            |                           |                                                                               |
| 70 Tower Office Park, Woburn, MA 01801, (617) 935-6668   |       |                      |                                          |                                |                             |                                                            |                           |                                                                               |
| 2200CRX                                                  |       | intelligent/graphics | 7-inch, monochrome                       | 64x24                          | RS232C                      |                                                            | 1,900(Q1)                 | bar graphs, plotting                                                          |
| <b>ALTOS COMPUTER SYSTEMS</b>                            |       |                      |                                          |                                |                             |                                                            |                           |                                                                               |
| 2641 Orchard Parkway, San Jose, CA 95134, (408) 946-6700 |       |                      |                                          |                                |                             |                                                            |                           |                                                                               |
| Altos III                                                |       | intelligent          | 14-inch, green                           | 132x26                         | RS232C                      | TeleVideo 1910                                             | 795(Q1)                   | 16 or 32 programmable function keys, split screen                             |
| Altos IV                                                 |       | intelligent          | 14-inch, green                           | 80x26                          | RS232C                      | ADDS VP; TeleVideo 925, 1910                               | 495(Q1)                   | 16 or 32 programmable function keys, split screen                             |
| <b>AMPEX CORP. (COMPUTER PRODUCTS DIV.)</b>              |       |                      |                                          |                                |                             |                                                            |                           |                                                                               |
| 200 N. Nash St., El Segundo, CA 90245, (213) 640-0150    |       |                      |                                          |                                |                             |                                                            |                           |                                                                               |
| 210 plus                                                 |       | intelligent          | 14-inch, monochrome                      | 132x25                         | RS232C                      | ADDS Viewpoint, Regent; Hazeltine; Lear Siegler; TeleVideo | 419(Q1)                   | 14 programmable function keys, line graphics, 7 national character sets       |
| 220                                                      |       | intelligent          | 14-inch, monochrome                      | 132x25                         | RS232C                      | DEC VT52, VT100, VT102, VT220                              | 529(Q1)                   | 15 programmable function keys, split screen, scroll                           |
| 232                                                      |       | intelligent          | 14-inch, monochrome                      | 132x25                         | RS232C                      | TeleVideo 925                                              | 499(Q1)                   | 10 programmable function keys, line graphics                                  |
| <b>ANN ARBOR TERMINALS INC.</b>                          |       |                      |                                          |                                |                             |                                                            |                           |                                                                               |
| 6175 Jackson Rd., Ann Arbor, MI 48103, (313) 663-8000    |       |                      |                                          |                                |                             |                                                            |                           |                                                                               |
| Ambassador XL                                            |       | intelligent/graphics | 15-inch, monochrome                      | 80x60                          | RS232C, RS422               | DEC VT52, VT100                                            | 1,595(Q1);<br>1,275(Q100) | programmable keyboard, scroll, zoom, line drawing graphics                    |
| VXL                                                      |       | intelligent/graphics | 15-inch, monochrome                      | 160x60                         | RS232C, RS422               | DEC VT52, VT100                                            | 2,795(Q1);<br>2,235(Q100) | programmable keyboard, line drawing graphics, scroll, zoom, 8 windows         |
| GXL                                                      |       | intelligent/graphics | 15-inch, monochrome                      | 80x60                          | RS232C, RS422, current loop | DEC VT52, VT100; Tektronix 4010, 4014                      | 3,090(Q1);<br>2,475(Q100) | bit-mapped graphics, PLOT 10 software, polygon draw and fill, scroll, zoom    |
| <b>CHI CORP.</b>                                         |       |                      |                                          |                                |                             |                                                            |                           |                                                                               |
| 26055 Emery Rd., Cleveland, OH 44128, (216) 831-2622     |       |                      |                                          |                                |                             |                                                            |                           |                                                                               |
| EMP-SI                                                   |       | intelligent          | 14-inch, monochrome                      | 133x25                         | RS232C, Centronics          | IBM, Sperry                                                | 1,675(Q1);<br>1,340(Q100) | reprogrammable keyboard, 101 programmable keys, 22 programmable function keys |
| MP-UTS                                                   |       | intelligent          | 14-inch, monochrome                      | 133x25                         | RS232C, Centronics          | Sperry                                                     | 1,125(Q1);<br>900(Q100)   | reprogrammable keyboard, 101 programmable keys, 22 programmable function keys |
| MP-3270                                                  |       | intelligent          | 14-inch, monochrome                      | 133x25                         | RS232C, Centronics          | IBM 3278                                                   | 1,125(Q1);<br>900(Q100)   | reprogrammable keyboard, 101 programmable keys, 22 programmable function keys |
| <b>CIE SYSTEMS INC.</b>                                  |       |                      |                                          |                                |                             |                                                            |                           |                                                                               |
| 2515 McCabe Way, Irvine, CA 92714, (714) 660-1800        |       |                      |                                          |                                |                             |                                                            |                           |                                                                               |
| CIE 7103                                                 |       | editing              | 14-inch, monochrome                      | 132x27                         | RS232C, RS422               | ADDS Viewpoint; DEC VT100; IBM 3180-1, 3180-2              | 645(Q1)                   | 80 function keys, split screen                                                |
| CIE 7800                                                 |       | editing              | 14-inch, monochrome                      | 132x27                         | RS232C, coax                | IBM 3178, 3191, 3278; DEC VT100                            | 795(Q1)                   | 24 function keys, RPQ support                                                 |
| CIE 7900                                                 |       | editing              | 13-inch, 7-color                         | 132x27                         | RS232C                      | IBM 3179, 3279; DEC VT100                                  | 1,695(Q1)                 | 24 function keys, printer port                                                |

## ALPHANUMERIC DISPLAY TERMINALS

| Company                                                                              | Model        | Terminal type        | Display size, color<br>(diagonal inches) | Screen format<br>(col. x lines) | Interfaces                               | Emulations                                                      | Price \$<br>(quantity)                | Notes, features                                                          |
|--------------------------------------------------------------------------------------|--------------|----------------------|------------------------------------------|---------------------------------|------------------------------------------|-----------------------------------------------------------------|---------------------------------------|--------------------------------------------------------------------------|
| <b>CIE TERMINALS INC.</b> <span style="float: right;">Circle 618</span>              |              |                      |                                          |                                 |                                          |                                                                 |                                       |                                                                          |
| 2505 McCabe Way, Irvine, CA 92714 (714) 660-1421                                     |              |                      |                                          |                                 |                                          |                                                                 |                                       |                                                                          |
|                                                                                      | CIT 20+      | editing              | 14-inch,<br>monochrome                   | 80x25                           | RS232C                                   | ADDS Viewpoint; Lear<br>Siegler ADM 3A, ADM<br>5; TeleVideo 910 | 399(Q1)                               | 32 shifted function keys, non-glare<br>screen, double-size characters    |
|                                                                                      | CIT 101XL    | editing              | 14-inch,<br>monochrome                   | 132x25                          | RS232C                                   | DEC VT100, CIT 101e                                             | 699(Q1)                               | 32 programmable function keys,<br>multi-page memory                      |
|                                                                                      | CIT 224      | editing              | 14-inch,<br>monochrome                   | 132x25                          | RS232C, RS422                            | DEC VT220                                                       | 699(Q1)                               | 60 function keys, 11 set-up menus                                        |
| <b>DATAMAXX USA CORP.</b> <span style="float: right;">Circle 619</span>              |              |                      |                                          |                                 |                                          |                                                                 |                                       |                                                                          |
| 1815 S. Gadsden St., Tallahassee, FL 32301, (904) 224-8213                           |              |                      |                                          |                                 |                                          |                                                                 |                                       |                                                                          |
|                                                                                      | 1200 Series  | intelligent          | 14-inch,<br>monochrome                   | 132x26                          | RS232C                                   | Data General, DEC<br>VT100, IBM 3278                            | 1,195-2,495(Q1);<br>850-1,695(Q100)   | 40 function keys                                                         |
|                                                                                      | 7000 Series  | intelligent          | 14-inch,<br>monochrome                   | 132x26                          | RS232C                                   | Data General, DEC<br>VT100, IBM 3278                            | 1,695-1,995(Q1);<br>1,360-1,695(Q100) | 40 function keys                                                         |
| <b>DATAMEDIA CORP.</b> <span style="float: right;">Circle 620</span>                 |              |                      |                                          |                                 |                                          |                                                                 |                                       |                                                                          |
| 11 Trafalgar Square, Nashua, NH 03063, (603) 886-1570                                |              |                      |                                          |                                 |                                          |                                                                 |                                       |                                                                          |
|                                                                                      | ColorScan 90 | intelligent/graphics | 12-inch, 8-color                         | 132x24                          | RS232C,<br>current loop                  | ADDS Regent 25,<br>Hazeltine 1420, Lear<br>Siegler ADM 3A       | 1,850(Q1);<br>1,203(Q100)             | 17 precoded keys, 8 user-defined<br>windows, non-volatile set-up<br>mode |
|                                                                                      | Elite 60     | editing              | 14-inch,<br>monochrome                   | 80x25                           | RS232C                                   | ANSI X3.64; DEC<br>VT100, VT101                                 | 950(Q1);<br>646(Q100)                 | 15 programmable, 12 precoded<br>keys; 1 page of memory                   |
|                                                                                      | Elite 90     | editing              | 14-inch,<br>monochrome                   | 132x24                          | RS232C,<br>current loop                  | ADDS Regent 25,<br>Hazeltine 1420, Lear<br>Siegler ADM 3A       | 925(Q1);<br>629(Q100)                 | 17 precoded keys, 8 user-defined<br>windows, non-volatile set-up<br>mode |
| <b>DATAPoint CORP.</b> <span style="float: right;">Circle 621</span>                 |              |                      |                                          |                                 |                                          |                                                                 |                                       |                                                                          |
| 9725 Datapoint Dr., San Antonio, TX 78284, (512) 699-7000                            |              |                      |                                          |                                 |                                          |                                                                 |                                       |                                                                          |
|                                                                                      | 7350         | editing/graphics     | 14-inch,<br>monochrome                   | 80x24                           | RS232C, RS422                            | Datapoint 8230                                                  | 1,495(Q1);<br>1,091(Q100)             | 8 function keys, 10 control keys,<br>split screen, character graphics    |
|                                                                                      | 8216         | editing/graphics     | 14-inch,<br>monochrome                   | 80x24                           | RS232C                                   | IBM PC, TeleVideo 925                                           | 599(Q1);<br>440(Q100)                 | 10 function keys, 10 control keys,<br>character graphics                 |
|                                                                                      | 8242         | editing/graphics     | 14-inch,<br>monochrome                   | 84x24                           | RS232C                                   | Datapoint 8220                                                  | 1,095(Q1);<br>799(Q100)               | 10 function keys, 5 control keys,<br>split screen, character graphics    |
| <b>DECISION DATA COMPUTER CORP.</b> <span style="float: right;">Circle 622</span>    |              |                      |                                          |                                 |                                          |                                                                 |                                       |                                                                          |
| 400 Horsham Rd., Horsham, PA 19044, (215) 674-3300                                   |              |                      |                                          |                                 |                                          |                                                                 |                                       |                                                                          |
|                                                                                      | 3761-41/61   | editing              | 14-inch,<br>monochrome                   | 80x24                           | twinax                                   | IBM 5291                                                        | 1,195(Q1)                             | 24 command keys,<br>record/play back                                     |
|                                                                                      | 3781-01/21   | editing              | 15-inch,<br>monochrome                   | 132x27                          | twinax                                   | IBM 3180, 5291                                                  | 1,650(Q1)                             | 24 command keys,<br>record/playback, RS232C<br>printer port              |
| <b>ENTERPRISE SYSTEMS CORP.</b> <span style="float: right;">Circle 623</span>        |              |                      |                                          |                                 |                                          |                                                                 |                                       |                                                                          |
| P.O. Box 698, Dover, NH 03820, (603) 742-7363                                        |              |                      |                                          |                                 |                                          |                                                                 |                                       |                                                                          |
|                                                                                      | DV7000       | intelligent          | 12-, 14-inch;<br>monochrome              | 84x24                           | RS232C, RS422,<br>RS423, current<br>loop | ANSI X3.64, Ann Arbor                                           |                                       | 10 function keys, printer buffer,<br>industrial                          |
|                                                                                      | DV8000       | intelligent/graphics | 14-inch,<br>16-color                     | 80x24                           | RS232C, RS422,<br>RS423                  | ANSI X3.64                                                      |                                       | screen editor, character and line<br>drawing graphics, industrial        |
|                                                                                      | DV9000       | intelligent/graphics | 14-inch,<br>16-color                     | 80x24                           | RS232C, RS422,<br>RS423                  | ANSI X3.64                                                      |                                       | screen editor, character and line<br>drawing graphics, industrial        |
| <b>ERICSSON INFORMATION SYSTEMS AB</b> <span style="float: right;">Circle 624</span> |              |                      |                                          |                                 |                                          |                                                                 |                                       |                                                                          |
| (Data Terminals Division, System 11), S-16398 Stockholm, Sweden, 46-8-7937000        |              |                      |                                          |                                 |                                          |                                                                 |                                       |                                                                          |
|                                                                                      | DU1110       | editing              | 15-inch,<br>monochrome                   | 80x24                           | twinax                                   | IBM 5251                                                        |                                       |                                                                          |
|                                                                                      | DU1111       | editing              | 12-inch,<br>monochrome                   | 80x24                           | twinax                                   | IBM 5291                                                        |                                       |                                                                          |
|                                                                                      | DU6225       | editing              | 15-inch,<br>monochrome                   | 80x24,<br>132 x 24              | RS423,<br>current loop                   | DEC VT220                                                       |                                       |                                                                          |
| <b>FALCO DATA PRODUCTS INC.</b> <span style="float: right;">Circle 625</span>        |              |                      |                                          |                                 |                                          |                                                                 |                                       |                                                                          |
| 1294 Hammerwood Ave., Sunnyvale, CA 94089, (408) 745-7123                            |              |                      |                                          |                                 |                                          |                                                                 |                                       |                                                                          |
|                                                                                      | F500         | intelligent          | 14-inch,<br>monochrome                   | 132x44                          | RS232C, RS422                            | ADDS, DEC, Hazeltine,<br>TeleVideo, Wyse                        | 795(Q1)                               | 16 function keys                                                         |
|                                                                                      | F5220        | intelligent          | 14-inch,<br>monochrome                   | 132x44                          | RS232C, RS422                            | DEC VT52, VT100,<br>VT200                                       | 595(Q1)                               | 13 function keys                                                         |
|                                                                                      | F5500        | intelligent          | 14-inch,<br>monochrome                   | 132x44                          | RS232C, RS422                            | ADDS Viewpoint,<br>Data General, IBM,<br>TeleVideo, Wyse        | 495(Q1)                               | 16 function keys                                                         |

## ALPHANUMERIC DISPLAY TERMINALS

| Company                                                                                             | Model          | Terminal type    | Display size, color<br>(diagonal inches) | Screen format<br>(col. x lines) | Interfaces                                           | Emulations                                             | Price \$<br>(quantity)    | Notes, features                                                          |
|-----------------------------------------------------------------------------------------------------|----------------|------------------|------------------------------------------|---------------------------------|------------------------------------------------------|--------------------------------------------------------|---------------------------|--------------------------------------------------------------------------|
| <b>GENERAL BUSINESS TECHNOLOGY INC.</b> <span style="float: right;">Circle 658</span>               |                |                  |                                          |                                 |                                                      |                                                        |                           |                                                                          |
| 1891 McGaw Ave., Irvine, CA 92714, (714) 261-1891                                                   |                |                  |                                          |                                 |                                                      |                                                        |                           |                                                                          |
|                                                                                                     | 7700DS         | dumb/graphics    | 14-inch,<br>monochrome                   | 80x25                           | twinax                                               | IBM 5291                                               | 1,450(Q1)                 | bit-mapped graphics                                                      |
|                                                                                                     | 7710DS         | dumb/graphics    | 14-inch,<br>monochrome                   | 80x25                           | twinax                                               | IBM 3179-2                                             | 1,550(Q1)                 | 24 function keys, bit-mapped graphics                                    |
| <b>GENERAL DIGITAL CORP.</b> <span style="float: right;">Circle 626</span>                          |                |                  |                                          |                                 |                                                      |                                                        |                           |                                                                          |
| 160 Chapel Rd., P.O. Box 1657, Manchester, CT 06040, (203) 647-9700                                 |                |                  |                                          |                                 |                                                      |                                                        |                           |                                                                          |
|                                                                                                     | VuePoint II    | intelligent      | 10½-inch,<br>monochrome                  | 40x12                           | RS232C, RS422,<br>RS423, RS485,<br>current loop, TTL |                                                        |                           | touch sensitive display, 3 pages of memory, 240 programmable touch areas |
|                                                                                                     | Smart VuePoint | intelligent      | 10½-inch,<br>monochrome                  | 40x12                           | RS232C, RS422,<br>RS423, RS485,<br>current loop, TTL |                                                        |                           | additional on-board CPU off-loads processing from controller             |
| <b>HEWLETT-PACKARD CO. (ROSEVILLE TERMINALS DIV.)</b> <span style="float: right;">Circle 627</span> |                |                  |                                          |                                 |                                                      |                                                        |                           |                                                                          |
| 8020 Foothills Blvd., Roseville, CA 95678, (916) 786-8000                                           |                |                  |                                          |                                 |                                                      |                                                        |                           |                                                                          |
|                                                                                                     | 2392A          | intelligent      | 12-inch,<br>monochrome                   | 80x24                           | RS232C, RS422,<br>Centronics                         | DEC VT52, VT100                                        | 1,375(Q1)                 | 8 function keys, 4 pages of memory                                       |
|                                                                                                     | 2394A          | intelligent      | 12-inch,<br>monochrome                   | 80x24                           | RS232C, RS422,<br>Centronics                         | DEC VT52, VT100                                        | 1,875(Q1)                 | 8 programmable function keys, 8 pages of memory                          |
| <b>HONEYWELL INFORMATION SYSTEMS INC.</b> <span style="float: right;">Circle 628</span>             |                |                  |                                          |                                 |                                                      |                                                        |                           |                                                                          |
| 200 Smith St., Waltham, MA 02154, (617) 895-6000                                                    |                |                  |                                          |                                 |                                                      |                                                        |                           |                                                                          |
|                                                                                                     | HDS1           | editing          | 14-inch,<br>monochrome                   | 80x25                           | RS232C, RS422                                        | ADDS, Hazeltine, Lear Siegler, TeleVideo, Wyse         | 525(Q1)                   | 10 programmable function keys                                            |
|                                                                                                     | HDS3           | editing          | 14-inch,<br>monochrome                   | 80x25,<br>132x25                | RS232C, RS422                                        | DEC VT52, VT100,<br>VT220                              | 750(Q1)                   | 14 programmable function keys                                            |
|                                                                                                     | HDS7           | editing          | 14-inch,<br>monochrome                   | 80x25,<br>132x25                | RS232C, RS422                                        | ANSI X3.64, VIP 7824                                   | 1,200(Q1)                 | 12 programmable function keys, scroll                                    |
| <b>HUMAN DESIGNED SYSTEMS INC.</b> <span style="float: right;">Circle 629</span>                    |                |                  |                                          |                                 |                                                      |                                                        |                           |                                                                          |
| 3440 Market St., Philadelphia, PA 19104, (215) 382-5000                                             |                |                  |                                          |                                 |                                                      |                                                        |                           |                                                                          |
|                                                                                                     | HDS2200        | editing          | 15-inch,<br>monochrome                   | 132x25                          | RS232C                                               | DEC VT52, VT100,<br>VT220                              | 795(Q1)                   | 42 function keys, 4 pages of memory                                      |
| <b>IBM CORP.</b> <span style="float: right;">Circle 630</span>                                      |                |                  |                                          |                                 |                                                      |                                                        |                           |                                                                          |
| 900 King St., Rye Brook, NY 10573, (914) 934-4828                                                   |                |                  |                                          |                                 |                                                      |                                                        |                           |                                                                          |
|                                                                                                     | 3162           | intelligent      | 14-inch,<br>monochrome                   | 29x29                           | RS232C, RS422A                                       | DEC VT52, VT100,<br>VT220                              | 640-724(Q1)               | 12 function keys, split screen, scroll                                   |
|                                                                                                     | 3163           | intelligent      | 12-inch,<br>monochrome                   |                                 | RS232C, RS422A                                       | DEC VT100,<br>TeleVideo 950                            | 895-985(Q1)               | 12 function keys                                                         |
| <b>INFORMER COMPUTER TERMINALS INC.</b> <span style="float: right;">Circle 631</span>               |                |                  |                                          |                                 |                                                      |                                                        |                           |                                                                          |
| 12781 Pala Dr., Garden Grove, CA 92641, (714) 891-1112                                              |                |                  |                                          |                                 |                                                      |                                                        |                           |                                                                          |
|                                                                                                     | 200-205        | intelligent      | 12-inch,<br>monochrome                   | 80x24                           | RS232C                                               | DEC VT102; IBM 3178,<br>3276; dual 3178/VT100          | 995(Q1);<br>796(Q100)     |                                                                          |
|                                                                                                     | 200-207        | intelligent      | 9-inch,<br>monochrome                    | 80x24                           | RS232C                                               | DEC VT102; IBM 3178,<br>3276, 5251; dual<br>3178/VT100 | 1,390(Q1);<br>1,112(Q100) |                                                                          |
|                                                                                                     | 200-213        | intelligent      | 10.2x5.7-inch,<br>monochrome             | 80x25                           | RS232C                                               | IBM 3276                                               | 3,500(Q1);<br>2,800(Q100) | 24 programmable function keys, built-in modem                            |
| <b>INTECOLOR CORP.</b> <span style="float: right;">Circle 632</span>                                |                |                  |                                          |                                 |                                                      |                                                        |                           |                                                                          |
| 225 Scientific Dr., Norcross, GA 30092, (404) 449-5961                                              |                |                  |                                          |                                 |                                                      |                                                        |                           |                                                                          |
|                                                                                                     | ColorTrend 210 | editing/graphics | 14-inch, 8-color                         | 132x24                          | RS232C                                               | ANSI X3.64; DEC VT52,<br>VT100                         | 1,295(Q1);<br>945(Q100)   | 12 programmable function keys, vector graphics                           |
|                                                                                                     | ColorTrend 220 | editing          | 14-inch, 8-color                         | 80x24                           | RS232C                                               | DEC VT52, VT100,<br>VT220                              | 1,695(Q1);<br>1,095(Q100) | 25 function keys, 15 programmable function keys                          |
| <b>ITT COURIER TERMINAL SYSTEMS INC.</b> <span style="float: right;">Circle 633</span>              |                |                  |                                          |                                 |                                                      |                                                        |                           |                                                                          |
| P.O. Box 29039, Phoenix, AZ 85038-9039, (602) 894-7000                                              |                |                  |                                          |                                 |                                                      |                                                        |                           |                                                                          |
|                                                                                                     | 1778           | editing          | 12-inch,<br>monochrome                   | 80x24                           | coax                                                 | IBM 3270                                               | 1,295(Q1)                 | 24 programmable function keys                                            |
|                                                                                                     | 9210           | editing          | 14-inch,<br>monochrome                   | 80x24                           | coax                                                 | IBM 3270                                               | 1,295(Q1)                 | 24 programmable function keys                                            |
|                                                                                                     | 9230/9236      | editing/graphics | 15-inch,<br>monochrome/7-color           | 132x24                          | RS232C                                               | DEC VT100, IBM 3270                                    | 1,995/2,595(Q1)           | 24 programmable function keys, split screen                              |
| <b>KIMTRON CORP.</b> <span style="float: right;">Circle 634</span>                                  |                |                  |                                          |                                 |                                                      |                                                        |                           |                                                                          |
| 1709 Junction Court, Bldg. 380, San Jose, CA 95112, (408) 436-6550                                  |                |                  |                                          |                                 |                                                      |                                                        |                           |                                                                          |
|                                                                                                     | KT-5 Version L | intelligent      | 14-inch,<br>monochrome                   | 132x24                          | RS232C                                               | ADDS, DEC, Hazeltine,<br>Lear Siegler, TeleVideo       | 399(Q1)                   | 82 programmable function keys                                            |

## ALPHANUMERIC DISPLAY TERMINALS

| Company                                                                                      | Model                | Terminal type        | Display size, color<br>(diagonal inches) | Screen format<br>(col.-x-lines) | Interfaces                                    | Emulations                                                              | Price \$<br>(quantity) | Notes, features                                                                              |
|----------------------------------------------------------------------------------------------|----------------------|----------------------|------------------------------------------|---------------------------------|-----------------------------------------------|-------------------------------------------------------------------------|------------------------|----------------------------------------------------------------------------------------------|
|                                                                                              | KT-7 Version L       | intelligent          | 14-inch,<br>monochrome                   | 80×25                           | RS232C                                        | Data General D100,<br>D200; DEC VT52,<br>VT100; TeleVideo 920,<br>925   | 499(Q1)                | 84 programmable function keys                                                                |
|                                                                                              | KT-7/PC Version L    | intelligent          | 14-inch,<br>monochrome                   | 80×25                           | RS232C                                        | IBM PC/AT/XT,<br>TeleVideo 925                                          | 499(Q1)                | 20 programmable function keys                                                                |
| <b>LEE DATA CORP.</b> <span style="float: right;">Circle 635</span>                          |                      |                      |                                          |                                 |                                               |                                                                         |                        |                                                                                              |
| 7075 Flying Cloud Dr., Eden Prairie, MN 55344, (612) 828-0300                                |                      |                      |                                          |                                 |                                               |                                                                         |                        |                                                                                              |
|                                                                                              | 1222                 | editing              | 15-inch,<br>monochrome                   | 80×24,<br>132×27                | coax                                          | IBM 3180                                                                | 1,885(Q1)              | 24 programmable function keys,<br>windowing, 4 sessions                                      |
|                                                                                              | 2131                 | editing              | 14-inch, 7-color                         | 80×24,<br>132×27                | coax                                          | IBM 3179, 3279                                                          | 2,265(Q1)              | 24 programmable function keys,<br>windowing, 4 sessions                                      |
| <b>LEE DATA CORP. (PHAZE TERMINAL DIV.)</b> <span style="float: right;">Circle 636</span>    |                      |                      |                                          |                                 |                                               |                                                                         |                        |                                                                                              |
| 7650 E. Redfield Rd., Scottsdale, AZ 85260, (602) 991-6855                                   |                      |                      |                                          |                                 |                                               |                                                                         |                        |                                                                                              |
|                                                                                              | 1179                 | editing              | 14-inch, 7-color                         | 80×24                           | Centronics                                    | IBM 3179, 3279                                                          | 1,865(Q1)              | 24 programmable function keys                                                                |
|                                                                                              | 1191                 | editing              | 14-inch,<br>monochrome                   | 80×24                           | coax                                          | IBM 3278, 3191                                                          | 1,115(Q1)              | 24 programmable function keys                                                                |
| <b>LIBERTY ELECTRONICS USA</b> <span style="float: right;">Circle 637</span>                 |                      |                      |                                          |                                 |                                               |                                                                         |                        |                                                                                              |
| 332 Harbor Way, South San Francisco, CA 94080, (415) 742-9960                                |                      |                      |                                          |                                 |                                               |                                                                         |                        |                                                                                              |
|                                                                                              | Freedom ONE          | intelligent          | 14-inch,<br>monochrome                   | 132×96                          | RS232C                                        | ADDS Viewpoint, Lear<br>Siegler ADM 31,<br>TeleVideo 950, Wyse<br>WY-50 | 449(Q1)                | 16 function keys                                                                             |
|                                                                                              | Freedom ONE plus     | intelligent          | 14-inch,<br>monochrome                   | 80×96                           | RS232C                                        | Freedom ONE                                                             | 549(Q1)                | 16 function keys                                                                             |
|                                                                                              | Freedom ONE<br>Turbo | intelligent          | 14-inch,<br>monochrome                   | 132×96                          | RS232C                                        | DEC VT52, VT100,<br>VT220; Data General<br>Dasher                       | 599(Q1)                | 16 function keys                                                                             |
| <b>LINK TECHNOLOGIES INC.</b> <span style="float: right;">Circle 638</span>                  |                      |                      |                                          |                                 |                                               |                                                                         |                        |                                                                                              |
| 47339 Warm Springs Blvd., Fremont, CA 94539, (415) 651-8000                                  |                      |                      |                                          |                                 |                                               |                                                                         |                        |                                                                                              |
|                                                                                              | 220                  | editing              | 14-inch,<br>monochrome                   | 132×26                          | RS232C, RS422,<br>RS423, current<br>loop      | DEC VT52, VT100,<br>VT220                                               | 595(Q1)                | 38 programmable function keys,<br>split screen                                               |
|                                                                                              | MC3                  | editing              | 14-inch,<br>monochrome                   | 132×44                          | RS232C, RS422,<br>Centronics,<br>current loop | DEC, Lear Siegler,<br>TeleVideo, Wyse                                   | 546(Q1)                | 40 programmable function keys,<br>split screen, parallel port, 6 pages<br>of memory          |
|                                                                                              | PC Term              | editing              | 14-inch,<br>monochrome                   | 132×26                          | RS232C,<br>current loop                       | PC Term, TeleVideo<br>925, Wyse WY-50                                   | 649(Q1)                | 40 programmable function keys,<br>split screen, bidirectional auxiliary<br>port              |
| <b>MEGADATA CORP.</b> <span style="float: right;">Circle 639</span>                          |                      |                      |                                          |                                 |                                               |                                                                         |                        |                                                                                              |
| 35 Orville Dr., Bohemia, NY 11716, (516) 589-6800                                            |                      |                      |                                          |                                 |                                               |                                                                         |                        |                                                                                              |
|                                                                                              | 8188-4               | editing              | 15-inch,<br>monochrome                   | 80×25                           | RS423                                         | OEM interfaced                                                          | 2,800(Q100)            | up to 100 function keys, split<br>screen                                                     |
|                                                                                              | 8188-6               | editing              | 15-inch,<br>monochrome                   | 135×26                          | RS232C, RS422                                 | Data General 410                                                        | 2,700(Q100)            | up to 100 function keys,<br>windowing                                                        |
|                                                                                              | 8188-7               | intelligent          | 15-inch,<br>monochrome                   | 132×32                          | RS232C,<br>Centronics, SCSI                   | ADDS, DEC, IBM,<br>Sperry, TeleVideo                                    | 2,250(Q100)            |                                                                                              |
| <b>MICRO-TERM INC.</b> <span style="float: right;">Circle 640</span>                         |                      |                      |                                          |                                 |                                               |                                                                         |                        |                                                                                              |
| 512 Rudder Rd., Fenton, MO 63026, (314) 343-6515                                             |                      |                      |                                          |                                 |                                               |                                                                         |                        |                                                                                              |
|                                                                                              | Foresight 4520       | intelligent          | 14-inch,<br>monochrome                   | 80×25,<br>132×25                | RS232C, RS423,<br>current loop                | ANSI X3.64; DEC VT52,<br>VT100, VT220                                   | 695(Q1)                | 15 programmable function keys,<br>split screen, 2 pages of memory                            |
|                                                                                              | Foresight 4525       | intelligent          | 14-inch,<br>monochrome                   | 80×25,<br>132×25                | RS232C, RS423,<br>current loop                | ANSI X3.64; DEC VT52,<br>VT100, VT220                                   | 795(Q1)                | 15 programmable function keys,<br>split screen, 7 pages of memory                            |
|                                                                                              | Foresight 4560       | intelligent/graphics | 14-inch,<br>monochrome                   | 80×25,<br>132×25                | RS232C, RS423,<br>current loop                | ANSI X3.64; DEC VT52,<br>VT100, VT220;<br>Tektronix 4010, 4014          | 1,295(Q1)              | 15 programmable function keys,<br>split screen, 7 pages of memory                            |
| <b>MODULAR COMPUTER SYSTEMS INC. (MODCOMP)</b> <span style="float: right;">Circle 641</span> |                      |                      |                                          |                                 |                                               |                                                                         |                        |                                                                                              |
| 1650 W. McNab Rd., Fort Lauderdale, FL 33310, (305) 977-1823                                 |                      |                      |                                          |                                 |                                               |                                                                         |                        |                                                                                              |
|                                                                                              | 4614-A               | editing/graphics     | 14-inch,<br>monochrome                   | 132×26                          | RS232C                                        |                                                                         | 550(Q1)                | 64 programmable function keys,<br>20 editing keys, split screen, line<br>graphics characters |
| <b>NCR CORP.</b> <span style="float: right;">Circle 642</span>                               |                      |                      |                                          |                                 |                                               |                                                                         |                        |                                                                                              |
| 1700 S. Patterson Blvd., Dayton, OH 45479, (513) 445-5000                                    |                      |                      |                                          |                                 |                                               |                                                                         |                        |                                                                                              |
|                                                                                              | 7930                 | editing/graphics     | 12-inch,<br>monochrome                   | 80×25                           | RS232C                                        | NCR 7900-1, 7901;<br>ADDS Viewpoint                                     | 995(Q1);<br>650(Q100)  | 24 function keys, split screen, 12<br>graphic symbols                                        |
|                                                                                              | 7958                 | editing              | 14-inch,<br>monochrome                   | 80×25                           |                                               | IBM 3270                                                                | 1,395(Q1)              | 24 function keys                                                                             |

## ALPHANUMERIC DISPLAY TERMINALS

| Company                                                                           | Model | Terminal type        | Display size, color<br>(diagonal inches) | Screen format<br>(col. x lines) | Interfaces                     | Emulations                                                         | Price \$<br>(quantity)    | Notes, features                                                 |
|-----------------------------------------------------------------------------------|-------|----------------------|------------------------------------------|---------------------------------|--------------------------------|--------------------------------------------------------------------|---------------------------|-----------------------------------------------------------------|
| <b>PARADYNE CORP.</b> <span style="float: right;">Circle 643</span>               |       |                      |                                          |                                 |                                |                                                                    |                           |                                                                 |
| 8550 Ulmerton Rd., Largo, FL 33540, (305) 530-2000                                |       |                      |                                          |                                 |                                |                                                                    |                           |                                                                 |
| 7812                                                                              |       | intelligent          | 12-inch,<br>monochrome                   | 80×24                           | current loop                   | IBM 3278 Model 2                                                   | 1,300(Q1);<br>1,135(Q100) | 24 function keys                                                |
| 7814                                                                              |       | intelligent/graphics | 14-inch,<br>monochrome                   | 132×43                          | RS232C,<br>current loop        | IBM 3278 Model 2, 3,<br>4, 5                                       | 2,400(Q1);<br>2,095(Q100) | 24 function keys                                                |
| 7913                                                                              |       | intelligent/graphics | 13-inch,<br>monochrome                   | 80×32                           | RS232C,<br>current loop        | IBM 3279 Model 2B, 3B                                              | 3,100(Q1);<br>2,700(Q100) | 24 function keys                                                |
| <b>PDS TECHNOLOGIES INC.</b> <span style="float: right;">Circle 644</span>        |       |                      |                                          |                                 |                                |                                                                    |                           |                                                                 |
| 2000 Black Rock Turnpike, Fairfield, CT 06430, (203) 333-5183                     |       |                      |                                          |                                 |                                |                                                                    |                           |                                                                 |
| Ruggedized                                                                        |       | editing              | 14-inch,<br>monochrome                   | 80×25                           | RS232C, RS422,<br>current loop | ADDS, DEC, Hazeltine,<br>Lear Siegler, TeleVideo                   |                           | 10 function keys, industrial                                    |
| <b>PLESSEY PERIPHERAL SYSTEMS</b> <span style="float: right;">Circle 645</span>   |       |                      |                                          |                                 |                                |                                                                    |                           |                                                                 |
| 17466 Daimler Ave., Irvine, CA 92714, (714) 261-9945                              |       |                      |                                          |                                 |                                |                                                                    |                           |                                                                 |
| PT224                                                                             |       | intelligent          | 14-inch,<br>monochrome                   | 132×24                          | RS232C,<br>current loop        | DEC VT52, VT100,<br>VT102, VT220                                   | 795(Q1);<br>585(Q100)     | 45 programmable function keys,<br>split screen, scroll          |
| <b>PRIME COMPUTER INC.</b> <span style="float: right;">Circle 646</span>          |       |                      |                                          |                                 |                                |                                                                    |                           |                                                                 |
| Prime Park, Natick, MA 01760, (617) 655-8000                                      |       |                      |                                          |                                 |                                |                                                                    |                           |                                                                 |
| PT200                                                                             |       | intelligent          | 14-inch,<br>monochrome or<br>15-color    | 132×48                          | RS232C, RS422                  |                                                                    | 895-1,695(Q1)             | 26 editing function keys, 26<br>application function keys       |
| <b>SCOTT SYSTEMS INC.</b> <span style="float: right;">Circle 647</span>           |       |                      |                                          |                                 |                                |                                                                    |                           |                                                                 |
| 99-C South St., Hopkinton, MA 01886, (617) 435-9578                               |       |                      |                                          |                                 |                                |                                                                    |                           |                                                                 |
| 5101                                                                              |       | intelligent          | 9-, 12-, 14-inch;<br>monochrome          | 64×30                           | RS232C,<br>current loop        | PARS                                                               | 3,500(Q1)                 | 24 function keys, split screen                                  |
| 5271                                                                              |       | intelligent          | 9-, 12-, 14-inch;<br>monochrome          | 64×30                           | RS232C,<br>current loop        | IBM 3270 bisynch                                                   | 3,500(Q1)                 | 24 function keys                                                |
| 5301                                                                              |       | intelligent          | 9-, 12-, 14-inch;<br>monochrome          | 64×30                           | RS232C,<br>current loop        | PARS                                                               | 3,500(Q1)                 | 24 function keys, split screen                                  |
| <b>TAB PRODUCTS CO.</b> <span style="float: right;">Circle 648</span>             |       |                      |                                          |                                 |                                |                                                                    |                           |                                                                 |
| 1400 Page Mill Rd., Palo Alto, CA 94304, (415) 852-2400                           |       |                      |                                          |                                 |                                |                                                                    |                           |                                                                 |
| E-22                                                                              |       | intelligent          | 15-inch,<br>monochrome                   | 132×27                          | RS232C                         | DEC VT52, VT100,<br>VT220                                          | 660(Q1);<br>395(Q100)     | 51 function keys, split screen, 2<br>pages of memory            |
| <b>TEC INC.</b> <span style="float: right;">Circle 649</span>                     |       |                      |                                          |                                 |                                |                                                                    |                           |                                                                 |
| 2727 N. Fairview Ave., P.O. Box 5646, Tucson, AZ 85703, (602) 792-2230            |       |                      |                                          |                                 |                                |                                                                    |                           |                                                                 |
| Data-Pad                                                                          |       | editing              | 9-inch,<br>monochrome                    | 80×16                           | RS232C                         | DEC, Hazeltine, Lear<br>Siegler, TeleVideo                         | 995(Q1)                   | 10 programmable function keys,<br>scroll, portable, LCD display |
| TEC ET 80                                                                         |       | editing              | 15-inch,<br>monochrome                   | 80×25                           | RS232C                         | ANSI X3.64                                                         | 1,795(Q1)                 | 16 programmable function keys,<br>split screen, scroll          |
| TEC ET 100                                                                        |       | editing              | 15-inch,<br>monochrome                   | 80×25                           | RS232C                         | DEC VT100                                                          | 1,795(Q1)                 | 16 programmable function keys,<br>split screen, scroll          |
| <b>TELEVIDEO INC.</b> <span style="float: right;">Circle 650</span>               |       |                      |                                          |                                 |                                |                                                                    |                           |                                                                 |
| 1170 Morse Ave., P.O. Box 3568, Sunnyvale, CA 94088-3568, (408) 745-7760          |       |                      |                                          |                                 |                                |                                                                    |                           |                                                                 |
| 905                                                                               |       | intelligent          | 14-inch,<br>monochrome                   | 80×24                           | RS232C,<br>current loop        | ADDS, Hazeltine, Lear<br>Siegler, Qume,<br>TeleVideo               | 409(Q1)                   | 32 programmable function keys                                   |
| 9220                                                                              |       | intelligent          | 14-inch,<br>monochrome                   | 80×24,<br>132×24                | RS232C, RS423,<br>current loop | DEC VT52, VT100,<br>VT220                                          | 619(Q1)                   | 30 function keys, 28 editing keys                               |
| PC Station                                                                        |       | editing              | 14-inch,<br>monochrome                   | 80×26,<br>132×26                | RS232C, parallel               | IBM PC; Kimtron<br>KT-7/PC; Link PC<br>Term; TeleVideo 905,<br>925 | 629(Q1)                   | IBM PC/AT-style keyboard                                        |
| <b>TELEX COMPUTER PRODUCTS INC.</b> <span style="float: right;">Circle 651</span> |       |                      |                                          |                                 |                                |                                                                    |                           |                                                                 |
| 6422 E. 41st St., Tulsa, OK 74135, (918) 627-1111                                 |       |                      |                                          |                                 |                                |                                                                    |                           |                                                                 |
| 078-2                                                                             |       | dumb                 | 12-inch,<br>monochrome                   | 80×24                           | RS232C                         |                                                                    | 1,295(Q1)                 | 24 command keys                                                 |
| 179-2                                                                             |       | dumb                 | 14-inch, 7-color                         | 80×24                           | RS232C                         |                                                                    | 2,095(Q1)                 | 24 command keys                                                 |
| 180-2                                                                             |       | dumb                 | 15-inch,<br>monochrome                   | 132×27                          | RS232C                         |                                                                    | 1,995(Q1)                 | 24 command keys                                                 |
| <b>TERMIFLEX CORP.</b> <span style="float: right;">Circle 652</span>              |       |                      |                                          |                                 |                                |                                                                    |                           |                                                                 |
| 316 Daniel Webster Highway, Merrimack, NH 03054, (608) 424-3700                   |       |                      |                                          |                                 |                                |                                                                    |                           |                                                                 |
| HT/40                                                                             |       | dumb                 |                                          | 2 lines × 16<br>characters      | RS232C                         |                                                                    | 395(Q1)                   | hand-held, LCD display                                          |
| HT/1000                                                                           |       | intelligent          |                                          | 4 lines × 16<br>characters      | RS232C                         |                                                                    | 795(Q1)                   | 4 function keys, LCD display,<br>hand-held, battery pack        |
| ST/32                                                                             |       | dumb                 |                                          | 2 lines × 16<br>characters      | RS232C                         |                                                                    | 195(Q1)                   | hand-held, LCD display                                          |

## ALPHANUMERIC DISPLAY TERMINALS

| Company                                                                     | Model | Terminal type    | Display size, color<br>(diagonal inches) | Screen format<br>(col. x lines) | Interfaces              | Emulations                                                           | Price \$<br>(quantity) | Notes, features                                                                       |
|-----------------------------------------------------------------------------|-------|------------------|------------------------------------------|---------------------------------|-------------------------|----------------------------------------------------------------------|------------------------|---------------------------------------------------------------------------------------|
| <b>VISUAL TECHNOLOGY INC.</b> <span style="float: right;">Circle 653</span> |       |                  |                                          |                                 |                         |                                                                      |                        |                                                                                       |
| 1703 Middlesex St., Lowell, MA 01851, (617) 459-4903                        |       |                  |                                          |                                 |                         |                                                                      |                        |                                                                                       |
| Visual 601                                                                  |       | editing/graphics | 14-inch,<br>monochrome                   | 132x50                          | RS232C, RS422,<br>RS423 | ADDS, Hazeltine, Lear<br>Siegler, Tektronix,<br>TeleVideo, Wyse      | 695(Q1)                | 48 function keys, split screen,<br>scroll, bit-mapped graphics, PLOT<br>10 compatible |
| Visual 602                                                                  |       | editing/graphics | 14-inch,<br>monochrome                   | 132x50                          | RS232C, RS422,<br>RS423 | ADDS, DEC, Hazeltine,<br>Lear Siegler, Tektronix,<br>TeleVideo, Wyse | 695(Q1)                | 45 function keys, split screen,<br>scroll, bit-mapped graphics, PLOT<br>10 compatible |
| Visual 603                                                                  |       | editing/graphics | 14-inch,<br>monochrome                   | 132x50                          | RS232C, RS422,<br>RS423 | DEC VT52, VT100,<br>VT220; Tektronix 4010,<br>4014                   | 695(Q1)                | 45 function keys, split screen,<br>scroll, bit-mapped graphics, PLOT<br>10 compatible |
| <b>WYSE TECHNOLOGY</b> <span style="float: right;">Circle 654</span>        |       |                  |                                          |                                 |                         |                                                                      |                        |                                                                                       |
| 3571 N. First St., San Jose, CA 95134, (408) 433-1000                       |       |                  |                                          |                                 |                         |                                                                      |                        |                                                                                       |
| WY-60                                                                       |       | intelligent      | 14-inch,<br>monochrome                   | 132x44                          | RS232C                  | ADDS, Hazeltine, IBM,<br>Lear Siegler, TeleVideo,<br>Wyse            | 599(Q1)                | 16 function keys, split screen                                                        |
| WY-85                                                                       |       | intelligent      | 14-inch,<br>monochrome                   | 132x26                          | RS232C                  | DEC VT52, VT100,<br>VT220                                            | 599(Q1)                | 15 programmable function keys                                                         |
| WY-350                                                                      |       | intelligent      | 14-inch, 8-color<br>palette              | 132x26                          | RS232C                  | ADDS, Hazeltine, Lear<br>Siegler, TeleVideo                          | 999(Q1)                | 16 programmable function keys,<br>split screen                                        |
| <b>ZENTEC CORP.</b> <span style="float: right;">Circle 655</span>           |       |                  |                                          |                                 |                         |                                                                      |                        |                                                                                       |
| 2400 Walsh Ave., Santa Clara, CA 95051, (408) 727-7662                      |       |                  |                                          |                                 |                         |                                                                      |                        |                                                                                       |
| ADM 220                                                                     |       | intelligent      | 14-inch,<br>monochrome                   | 80x25,<br>132x25                | RS232C, asynch<br>ASCII |                                                                      | 595(Q1)                | 15 function keys, scroll,<br>non-volatile set-up mode                                 |
| ADM 1000                                                                    |       | intelligent      | 14-inch,<br>monochrome                   | 80x25                           | RS232C, asynch          |                                                                      | 399(Q1)                | 4 programmable function keys                                                          |
| 8392                                                                        |       | intelligent      | 14-inch,<br>monochrome                   | 80x27,<br>132x27                | RS232C, RS422           | HP 2382A, 2392A,<br>2621B, 2622A                                     | 1,195(Q1)              | scroll                                                                                |

### REGIONAL SALES OFFICES

#### NEW ENGLAND

John J. Fahey  
Regional Manager  
199 Wells Ave.  
Newton, MA 02159  
(617) 964-3730

#### NEW YORK/MID-ATLANTIC

Joseph T. Porter  
Regional Manager  
1873 Route 70, Suite 302  
Cherry Hill, NJ 08003  
(609) 751-0170  
in N.Y.: (212) 972-0058

#### SOUTHEAST

Larry Pullman  
Regional Manager  
6540 Powers Ferry Rd.  
Suite 170  
Atlanta, GA 30339  
(404) 955-6500

#### MIDWEST

Rob Robinson  
Regional Manager  
Lynne Graham  
Sales Coordinator  
Cahners Plaza  
1350 E. Touhy Ave.  
P.O. Box 5080  
Des Plaines, IL 60018  
(312) 635-8800

#### SOUTHWEST

Don Ward  
Regional Manager  
9330 LBJ Freeway, Suite 1060  
Dallas, TX 75243  
(214) 644-3683

#### MOUNTAIN STATES

John Huff  
Regional Manager  
270 St. Paul St.  
Denver, CO 80206  
(303) 388-4511

#### SOUTHERN CALIFORNIA/ NEVADA

Len Ganz  
Regional Manager  
18818 Teller Ave.  
Irvine, CA 92715  
(714) 851-9422

#### NORTHERN CALIFORNIA/ NORTHWEST

Frank Barbagallo  
Northwestern Regional Sales Manager  
Rick Jamison  
Regional Manager  
Sherman Building, Suite 100  
3031 Tisch Way  
San Jose, CA 95128  
(408) 243-8838

#### BENELUX

Jan Dawson  
Tracey Lehane  
Cahners Publishing Co.  
27 Paul St.  
London EC2A 4JU, England  
011-44-1-628-7030  
Telex: 914911  
Fax: 01-628-5984

#### ISRAEL

Eliam Marketing Group  
13 Haifa St., P.O. Box 33439  
Tel Aviv, Israel  
972-3-252967  
Telex: 341667

#### ITALY AND FRANCE

Alasdair Melville  
Cahners Publishing Co.  
27 Paul St.  
London, EC2A 4JU, England  
011-44-1-628-7030  
Telex: 914911  
Fax: 01-628-5984

#### JAPAN

Kaoru Hara  
Dynaco International Inc.  
Suite 1003, Sun-Palace Shinjuku  
8-12-1 Nishishinjuku, Shinjuku-ku  
Tokyo, 160, Japan  
03-366-8301  
Telex: J2322609 DYNACO

#### KOREA

Korea Media Inc.  
Room 110, A-11 Bldg. 49-4  
Hoilyundong 2-Ka, Chung-ku  
C.P.O. Box 2314  
Seoul, Korea  
02-775-9880  
Telex: K26249

#### SCANDINAVIA

Martin Sutcliffe  
Cahners Publishing Co.  
27 Paul St.  
London, EC2A 4JU, England  
011-44-1-628-7030  
Telex: 914911  
Fax: 01-628-5984

#### TAIWAN

Donald Shapiro  
Trade Winds, 2nd Floor  
132 Hsin Yi Rd., Sec. 2  
Taipei, Taiwan  
3932718 & 3913251  
Telex: 24117 FC Trade

#### UNITED KINGDOM

Jan Dawson  
Tracey Lehane  
Cahners Publishing Co.  
27 Paul St.  
London, EC2A 4JU, England  
011-44-1-628-7030  
Telex: 914911  
Fax: 01-628-5984

#### WEST GERMANY/ SWITZERLAND/ AUSTRIA/EASTERN BLOC

Uwe Kretzschmar  
Cahners Publishing Co.  
27 Paul St.  
London, EC2A 4JU, England  
011-44-1-628-7030  
Telex: 914911  
Fax: 01-628-5984

#### Mini-Micro Marketplace

Carol Flanagan  
275 Washington St.  
Newton, MA 02158  
(617) 964-3030

#### Direct-Response Postcards

Carol Flanagan  
275 Washington St.  
Newton, MA 02158  
(617) 964-3030

#### Career Opportunities

Carol Flanagan  
Recruitment Advertising Manager  
275 Washington St.  
Newton, MA 02158  
(617) 964-3030

#### Cahners Magazine Division

William Platt, President  
Tim Burkholder, Vice President  
Computer Group  
Tom Dellamaria, VP/Production

#### Promotion Staff

Katherine Doyle  
Director, Marketing Services  
Beth-Ann Legare  
Promotion Assistant

#### Circulation

Denver, CO:  
(303) 388-4511  
Sherri Gronli  
Group Manager



Texas Instruments technologies  
put the power of printers in a  
whole new light.



# We've put TI technologies

Right now, there's a revolution going on in the office. Because with the speed, quality and affordability of the new generation of laser printers, applications like desktop publishing are changing the way businesses communicate forever.

**The first family of second-generation laser printers.**

The first generation of laser printers represented a major step forward in printing capabilities. But that was just the beginning.

Thanks to advanced, second-generation print engines and proprietary TI controllers, we've created a family of laser printers that offers improved com-

patibility and up to 10 times the duty cycle, 15 times the machine life and five times the paper capacity of their first-generation counterparts.

For example, first-generation lasers were capable of handling 3,000 pages per month. But with TI OmniLaser™ Printers, you can produce as many as 25,000 pages a month, and at speeds of eight and 15 pages per minute.

**It's what we put into OmniLaser Printers that makes their output so special.**

OmniLaser Printers combine advanced electro-photographic technology with the latest semiconductor technology. Text and images are produced with outstanding resolution by

addressing over 7.5 million dots on each page. But since each dot occupies a separate area of memory, it takes large-scale



*TI's expertise in semiconductor technology allows us to create specialized components to provide laser printer users with increased ease-of-use, reliability and power.*



# to work on paper.

processing and memory power to manipulate, store and print these documents.

That's why our OmniLaser Printers perform so well. Because when it comes to semiconductor technology, TI wrote the book. Starting with our invention of the integrated circuit back in 1958, and continuing today with our Mega-Chip™ technologies that produce advanced semiconductor systems-on-a-chip, nobody has done more to increase the power, density and capability of the devices that are becoming the heart of laser printers.

The intelligence inside an OmniLaser Printer is a case in point. It's a proprietary TI controller that's so powerful, it has more sheer processing capability than you'd find inside an IBM® PC AT™ computer.

We also made our OmniLaser Printers easier to operate. Because when you've been building printers as long as TI has, you develop an understanding of ergonomic factors. Like the convenience that comes from placing virtually all of the operator controls on an easily accessible front panel.

**With PostScript®, the integration of text and graphics is anything but an afterthought.**

PostScript, a standard in the desktop publishing industry, is a page description language that lets you control the placement, size and appearance of every element in your document. It's supported by both the OmniLaser 2108 and 2115 models, and with it you can produce cleaner, clearer, more professional output than was ever previously possible.

The OmniLaser Printer family also includes models that emulate the features of many printer standards, including HP LaserJet Plus, HPGL and IBM Pro Printer™, and since they're compatible with IBM, Apple® and others, there's an OmniLaser printer that's right for most applications.



*These convenient plug-in cartridges provide for easy font selection, either manually or under software control.*

*The TI printer family includes laser printers, forms printers, personal printers and high-output models designed for shared-resource environments.*

▶ See back page for more information.



# The printers you need if your needs are demanding.

## Our family also includes shared-resource serial-impact printers.

Most shared-resource environments are pretty tough on the hardware involved. So it follows that the more widely your resource is shared, the tougher it'll need to be. Which is one good reason to consider our OMNI 800™ family.

Our Model 810, for example, has become the standard for heavy-duty system printers. Over the years, they've proved themselves to be so durable, most of the world's largest airlines depend on them for ticket printing.

Then there's our Model 880s, which feature high-throughput, near-letter-quality printing and high-resolution raster graphics for data processing environments. And just about the only maintenance they require is the occasional ribbon change.

## Increase operator productivity and eliminate forms waste.

The latest addition to our printer family is the Model 885 demand document printer. Just like the other family members, it's designed to be rugged and offer superior paper handling. But its differences make it ideal for applications where space is limited and paper waste is a consideration.

We've added a zero tear-off capability that eliminates forms waste. Simply put, it uses just one form where most printers would also use a second. It's front-loading, handles up to five-part forms with ease, and thanks to its small footprint, fits on a desk or countertop.



TI's 885 demand document printer includes a zero tear-off capability to eliminate forms waste.

## Mini or mainframe, our printers connect to IBM.

Plug in TI's SNA/SDLC coax option and you can connect many of our durable printers to your IBM 3270 system quickly and cost-effectively. In the same way, plug in the TI Twinax option, and you can connect a TI printer to your System 34, 36 or 38.

## The personal printers.

Our family of personal printers is well known for its sturdy qualities. We build them to offer industrial strength and design durability, coupled with convenient features like easily changeable font cartridges.

They feature dual-mode, letter-quality, color and graphics printing, and come in both 80- and 132-column models. And since they're compatible with most PC hardware and software on the

market, they can help in virtually any application.

## Durability and technology. A combination that's engineered to work for you.

As you can probably tell, there's a broad range of TI printers designed to fill most any need. And as different as they are in function, they have a couple of things in common: durable design and advanced technology.

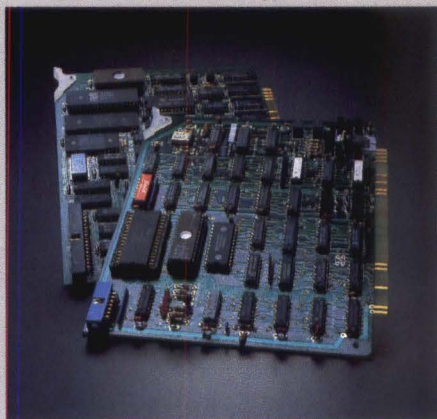

Optional interface boards make TI printers compatible with IBM's 3270 protocol, or with System 34, 36 or 38 minicomputers.

At Texas Instruments, building printers that deliver these qualities isn't just a goal, it's a commitment. We call it putting TI technologies to work on paper. And all you need to do to put it to work for you is call us toll-free at 1-800-527-3500. Call us soon. Because with your input, we can get to work on improving your output.

31672  
© 1987 TI

OmniLaser, MegaChip and OMNI 800 are trademarks of Texas Instruments Incorporated.

IBM is a registered trademark and PC, AT and Pro Printer are trademarks of International Business Machines Corporation.

PostScript is a registered trademark of Adobe Systems, Inc.

Apple is a registered trademark of Apple Computer, Inc.

  
**TEXAS  
INSTRUMENTS**

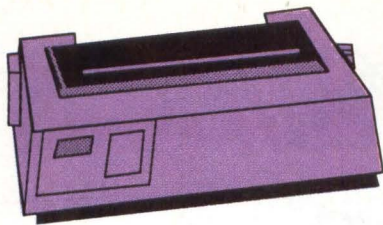

# MATRIX CHARACTER PRINTERS

| Company                                                                              | Model                        | Print method (matrix size) | Print speed (cps) | Characters/line          | Interfaces (Transmission rate)                                        | Price \$ (quantity) | Notes, features                                                      |
|--------------------------------------------------------------------------------------|------------------------------|----------------------------|-------------------|--------------------------|-----------------------------------------------------------------------|---------------------|----------------------------------------------------------------------|
| <b>3M CO. (TELETERMINAL PRODUCTS)</b> <span style="float: right;">Circle 566</span>  |                              |                            |                   |                          |                                                                       |                     |                                                                      |
| 311 Turquoise St., Milpitas, CA 95035, (408) 943-1970                                |                              |                            |                   |                          |                                                                       |                     |                                                                      |
|                                                                                      | 1902/1912                    | thermal (5x7)              | 40                | 40, 80                   | RS232C (300 to 9.6K bps)                                              | 299(Q1)             | bit-image graphics                                                   |
|                                                                                      | 1904/1914                    | thermal (5x7)              | 40                | 40, 80                   | Centronics                                                            | 289(Q1)             | bit-image graphics                                                   |
| <b>ADVANCED MATRIX TECHNOLOGY INC.</b> <span style="float: right;">Circle 567</span> |                              |                            |                   |                          |                                                                       |                     |                                                                      |
| 1157 Tourmaline Dr., Newbury Park, CA 91320, (805) 499-8741                          |                              |                            |                   |                          |                                                                       |                     |                                                                      |
|                                                                                      | AMT 2000 Office Printer      | impact                     | 45, 100, 250      |                          | RS232C, Centronics, ASCII parallel, Diablo, Qume, NEC (110-19.2K bps) | 1,845(Q1)           | color printing for graphics and text, noise level less than 55 dB(a) |
|                                                                                      | AMT 2100 Office Printer      | impact                     | 45, 100, 250      |                          | RS232C, Centronics, ASCII parallel, Diablo, Qume, NEC (110-19.2K bps) | 1,645(Q1)           | color printing for graphics and text, noise level less than 55 dB(a) |
| <b>ALPS AMERICA</b> <span style="float: right;">Circle 568</span>                    |                              |                            |                   |                          |                                                                       |                     |                                                                      |
| 3553 N. First St., San Jose, CA 95134, (408) 946-6000                                |                              |                            |                   |                          |                                                                       |                     |                                                                      |
|                                                                                      | ALQ224                       | impact (24x36)             | 240               | 80, 96, 160              | RS232C, Centronics                                                    | 695(Q1)             | 7-color printing, bit-image graphics                                 |
|                                                                                      | P2000                        | impact (18x23)             | 250               | 136, 163, 272            | RS232C, Centronics                                                    | 995(Q1)             | bit-image graphics                                                   |
|                                                                                      | P2424C                       | impact (24x36)             | 360               | 136, 163, 272            | RS232C, Centronics                                                    | 1,395(Q1)           | 7-color printing, bit-image graphics                                 |
| <b>APPLE COMPUTER INC.</b> <span style="float: right;">Circle 569</span>             |                              |                            |                   |                          |                                                                       |                     |                                                                      |
| 20525 Mariani Ave., Cupertino, CA 95014, (408) 996-1010                              |                              |                            |                   |                          |                                                                       |                     |                                                                      |
|                                                                                      | Imagewriter II               | impact (7x8)               | 250               | programmable             | Appletalk, serial                                                     | 595(Q1)             | color printing, bit-mapped graphics                                  |
| <b>BROTHER INTERNATIONAL CORP.</b> <span style="float: right;">Circle 570</span>     |                              |                            |                   |                          |                                                                       |                     |                                                                      |
| 8 Corporate Place, Piscataway, NJ 08854, (201) 981-0300                              |                              |                            |                   |                          |                                                                       |                     |                                                                      |
|                                                                                      | M-1709                       | impact (7x9)               | 50, 200, 240      | 136                      | RS232C, Centronics (9.6K bps)                                         | 699(Q1); 517(Q100)  | bit-image graphics, noise level 55 dB(a)                             |
|                                                                                      | M-1724                       | impact (18x24)             | 60, 72, 180, 216  | 136                      | Centronics, RS232C (9.6K bps)                                         | 899(Q1)             | graphics                                                             |
|                                                                                      | M-4018                       | impact (9x11)              | 100, 400-480      | 136                      | Centronic, RS232C (9.6K bps)                                          | 1,895(Q1)           | color printing, graphics                                             |
| <b>C. ITOH ELECTRONICS INC.</b> <span style="float: right;">Circle 571</span>        |                              |                            |                   |                          |                                                                       |                     |                                                                      |
| 19300 S. Hamilton Ave., Torrance, CA 90248, (213) 327-9100                           |                              |                            |                   |                          |                                                                       |                     |                                                                      |
|                                                                                      | 9700                         | impact (24x33)             | 100-250           | 272, programmable        | RS232C, Centronics (19.2K bps)                                        | 1,395(Q1)           | bidirectional graphics, quiet mode, 32K-byte buffer                  |
|                                                                                      | 9815                         | impact (18x36)             | 135-400           | 272, programmable        | RS232C, Centronics (19.2K bps)                                        | 1,995(Q1)           | bidirectional graphics, programmable font cartridges                 |
|                                                                                      | TPX-80                       | thermal (24x15)            | 50, 80            | 80, 96, 136              | Centronics (9.6K bps)                                                 | 350(Q1)             | color printing, noise level less than 50 dB(a)                       |
| <b>CIE TERMINALS INC.</b> <span style="float: right;">Circle 572</span>              |                              |                            |                   |                          |                                                                       |                     |                                                                      |
| 2505 McCabe Way, Irvine, CA 92714, (714) 660-1421                                    |                              |                            |                   |                          |                                                                       |                     |                                                                      |
|                                                                                      | Tri Printer Model 10, 20, 30 | impact (17x16)             | 88-350            | 233, programmable        | RS232C, Centronics (19.2K bps)                                        | 1,995(Q1)           | removable interface, plug-in font cartridge                          |
| <b>CITIZEN AMERICA CORP.</b> <span style="float: right;">Circle 573</span>           |                              |                            |                   |                          |                                                                       |                     |                                                                      |
| 2425 Colorado Ave., Santa Monica, CA 90404, (213) 453-0614                           |                              |                            |                   |                          |                                                                       |                     |                                                                      |
|                                                                                      | 120D                         | impact (9x9)               | 25, 120           | 40, 48, 80, 96, 136, 160 | parallel                                                              | 269(Q1)             | graphics                                                             |
|                                                                                      | MSP-10/15                    | impact (9x9)               | 40, 160           | 40-136/68-231            | parallel                                                              | 499/599(Q1)         | graphics                                                             |
|                                                                                      | MSP-20/25                    | impact (9x9)               | 50, 200           | 40-160/68-272            | parallel                                                              | 499/749(Q1)         | graphics                                                             |
| <b>DATAPRODUCTS CORP.</b> <span style="float: right;">Circle 574</span>              |                              |                            |                   |                          |                                                                       |                     |                                                                      |
| 6200 Canoga Ave., Woodland Hills, CA 91365, (818) 887-8000                           |                              |                            |                   |                          |                                                                       |                     |                                                                      |
|                                                                                      | 8070 PLUS                    | impact (18x9)              | 100, 300, 400     | 132, 158, 226            | RS232C, Centronics (9.6K bps)                                         | 2,099(Q1)           | color printing, bit-image graphics                                   |

# Four Lines. No Waiting.



Our new CI-400 and CI-800 dot matrix line printers just added an extra way to get things done fast: A fourth speed we call our *EXPRESS* line. Which is going to make three-speed line printers look old-fashioned and awkward. And a thing of the past.

The four-speed CI-400 and CI-800 printers can print just about anything that your business needs. The CI-400, for example, prints out 400 lines per minute for high-speed data processing assignments. On the other line, tight and accurate letter quality at 85 lpm. In between you get 300 lpm for crisp, high-contrast bar codes and graphics, and a convenient 200 lpm memo mode.

The CI-800 takes four speeds even further. For even faster flexibility at 170, 400, 600 and 800 lines per minute.

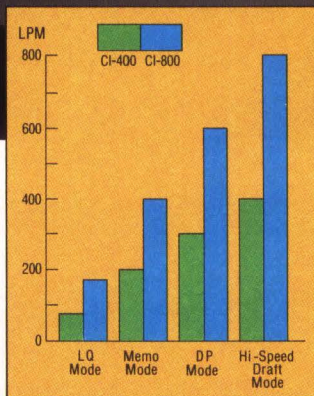

No matter what speed's on line, both printers use C. Itoh's proprietary long-life print head design, and a small dot wire to fill those hard-to-reach corners for corporate letter quality correspondence and solid industry-specified bar codes.

All of which means you don't have to change lines to use one printer for one job and a different printer for another. Because the four speeds are all in one. Ready and waiting.

The new CI-400 and CI-800 line printers. You'll like our new line. In four different ways.

For more information on the CI-400 and CI-800, contact CIE Terminals, a C. Itoh company, 2505 McCabe Way, Irvine, CA 92714; or call (714) 660-1421 or our toll-free number (800) 624-2516.

**C. ITOH**  
CIE Terminals

© 1987 CIE Terminals, Inc.

CIE Terminals, Inc., 2505 McCabe Way, Irvine, CA 92714 • Telephone: (714) 660-1421 (800) 624-2516

CIRCLE NO. 80 ON INQUIRY CARD

## MATRIX CHARACTER PRINTERS

| Company                                                                               | Model       | Print method<br>(matrix size) | Print speed<br>(cps) | Characters/line                | Interfaces<br>(Transmission rate)                        | Price \$<br>(quantity)        | Notes, features                                              |
|---------------------------------------------------------------------------------------|-------------|-------------------------------|----------------------|--------------------------------|----------------------------------------------------------|-------------------------------|--------------------------------------------------------------|
| <b>DATASOUTH COMPUTER CORP.</b> <span style="float: right;">Circle 575</span>         |             |                               |                      |                                |                                                          |                               |                                                              |
| 4216 Stuart Andrew Blvd., Charlotte, NC 28210, (704) 523-9500                         |             |                               |                      |                                |                                                          |                               |                                                              |
|                                                                                       | DS 180      | impact<br>(9x7)               | 180                  |                                | RS232C, Centronics<br>(110-9.6K bps)                     | 1,395(Q1)                     | dot-addressable graphics                                     |
|                                                                                       | DS 220      | impact<br>(9x7)               | 220                  |                                | RS232C, Centronics<br>(110-9.6K bps)                     | 1,695(Q1)                     | dot-addressable graphics                                     |
| <b>DICONIX INC. (KODAK CO.)</b> <span style="float: right;">Circle 576</span>         |             |                               |                      |                                |                                                          |                               |                                                              |
| 3100 Research Blvd., Dayton, OH 45420, (513) 259-3100                                 |             |                               |                      |                                |                                                          |                               |                                                              |
|                                                                                       | 150         | ink jet                       | 150                  | 85                             | RS232C, Centronics                                       | 479(Q1)                       | graphics, light weight, portable                             |
| <b>EPSON AMERICA INC.</b> <span style="float: right;">Circle 577</span>               |             |                               |                      |                                |                                                          |                               |                                                              |
| 2780 Lomita Blvd., Torrance, CA 90505, (213) 539-9140                                 |             |                               |                      |                                |                                                          |                               |                                                              |
|                                                                                       | EX-800      | impact<br>(9x9)               | 300                  | 80, 96                         | parallel, serial<br>(300-9.6K bps)                       | 749(Q1)                       | color printing, graphics                                     |
|                                                                                       | EX-1000     | impact<br>(9x9)               | 300                  | 80, 96                         | serial, parallel<br>(300-9.6K bps)                       | 995(Q1)                       | color printing, graphics                                     |
|                                                                                       | LQ-2500     | impact<br>(18x18)             | 324                  | 136, 163                       | serial, parallel<br>(300-9.6K bps)                       | 1,595(Q1)                     | color printing, graphics                                     |
| <b>ERGO SYSTEMS INC.</b> <span style="float: right;">Circle 578</span>                |             |                               |                      |                                |                                                          |                               |                                                              |
| 1758 Junction Ave., Suite G, San Jose, CA 95112, (408) 436-7722                       |             |                               |                      |                                |                                                          |                               |                                                              |
|                                                                                       | HUSH 80     | thermal<br>(6x7)              | 80                   | 40, 80, 160,<br>programmable   | RS232C, Centronics<br>(300-1200 bps)                     | 165-230(Q1);<br>132-184(Q100) | bit-mapped graphics, portable                                |
| <b>FACIT INC.</b> <span style="float: right;">Circle 579</span>                       |             |                               |                      |                                |                                                          |                               |                                                              |
| 9 Executive Park Dr., P.O. Box 334, Merrimack, NH 03054-0334, (603) 424-8000          |             |                               |                      |                                |                                                          |                               |                                                              |
|                                                                                       | 4528        | impact<br>(9x9)               | 165-225              | 80, 136                        | RS232C, Centronics<br>(9.6K bps)                         | 1,175-1,895(Q1)               | bit-mapped graphics                                          |
|                                                                                       | B3350       | impact<br>(18x18)             | 200                  | 80, 136,<br>programmable       | RS232C, Centronics<br>(9.6K bps)                         | 1,195-1,265(Q1)               | color printing, bit-mapped graphics                          |
|                                                                                       | C7500       | impact<br>(18x18)             | 400                  | 80, 136,<br>programmable       | RS232C, Centronics<br>(9.6K bps)                         | 1,195-2,495(Q1)               | color printing, bit-mapped graphics                          |
| <b>FLORIDA DATA CORP.</b> <span style="float: right;">Circle 580</span>               |             |                               |                      |                                |                                                          |                               |                                                              |
| 600D John Rodas Blvd., Melbourne, FL 32935, (305) 259-4700                            |             |                               |                      |                                |                                                          |                               |                                                              |
|                                                                                       | 130         | impact<br>(8x12)              | 75-600               | 85-132, 237                    | RS232C, Centronics,<br>Dataproducts<br>(up to 19.2K bps) | 3,995(Q1)                     |                                                              |
|                                                                                       | 3000        | impact<br>(8x12)              | 195-600              | 85-132, 237                    | RS232C, Centronics,<br>Dataproducts<br>(up to 19.2K bps) | 3,495(Q1)                     |                                                              |
| <b>FUJITSU AMERICA INC.</b> <span style="float: right;">Circle 581</span>             |             |                               |                      |                                |                                                          |                               |                                                              |
| 3055 Orchard Dr., San Jose, CA 95134, (408) 946-8777                                  |             |                               |                      |                                |                                                          |                               |                                                              |
|                                                                                       | DL2400      | impact<br>(36x24)             | 60, 180              | 136                            | Centronics, IBM<br>(200-9.6K bps)                        | 1,195(Q1)                     | color printing; graphics; double,<br>triple bin sheet feeder |
|                                                                                       | DL2600      | impact<br>(36x24)             | 80, 240              | 136                            | RS232C, Centronics,<br>Diablo, IBM<br>(600-9.6K bps)     | 1,795(Q1)                     | color printing; graphics; double,<br>triple bin sheet feeder |
|                                                                                       | DX2100/2200 | impact<br>(18x16)             | 44, 220              | 80, 136                        | RS232C, Centronics,<br>Epson<br>(200-9.6K bps)           | 545/695(Q1)                   | graphics                                                     |
| <b>GENERAL BUSINESS TECHNOLOGY INC.</b> <span style="float: right;">Circle 582</span> |             |                               |                      |                                |                                                          |                               |                                                              |
| 1891 McGaw Ave., Irvine, CA 92714, (714) 261-1891                                     |             |                               |                      |                                |                                                          |                               |                                                              |
|                                                                                       | 5220DP      | impact<br>(9x9, 9x18)         | 400                  | up to 198                      | twinax                                                   | 3,995(Q1)                     |                                                              |
|                                                                                       | 5222DP      | impact<br>(9x11, 17x11)       | 200                  | up to 198                      | twinax                                                   | 2,495(Q1)                     |                                                              |
|                                                                                       | 5227FA      | impact<br>(9x9)               | 120                  | up to 132                      | twinax                                                   | 1,995(Q1)                     |                                                              |
| <b>GENICOM CORP.</b> <span style="float: right;">Circle 583</span>                    |             |                               |                      |                                |                                                          |                               |                                                              |
| Genicom Dr., Waynesboro, VA 22980, (703) 949-1170, (800) 437-7468                     |             |                               |                      |                                |                                                          |                               |                                                              |
|                                                                                       | 1020/1025   | impact<br>(36x18)             | 100, 200             | 136-226/80-137<br>programmable | RS232C, Centronics,<br>Diablo, Epson, IBM<br>(9.6K bps)  | 998/798(Q1)                   | dot-addressable, block, line<br>drawing graphics             |
|                                                                                       | 3000 Series | impact<br>(21x18)             | 90-180, 300-400      | 136-244,<br>programmable       | RS232C, Centronics,<br>Diablo, IBM<br>(9.6K bps)         | 1,995-2,645(Q1)               | dot-addressable, block, line<br>drawing graphics             |
|                                                                                       | 3210        | impact<br>(9x18)              | 60, 240              | 132-226,<br>programmable       | RS232C, Centronics,<br>IBM, Okidata<br>(9.6K bps)        | 1,495(Q1)                     | dot-addressable, block, line<br>drawing graphics             |
| <b>HEWLETT-PACKARD CO.</b> <span style="float: right;">Circle 584</span>              |             |                               |                      |                                |                                                          |                               |                                                              |
| P.O. Box C-006, Vancouver, WA 98668-C006, (206) 254-8110                              |             |                               |                      |                                |                                                          |                               |                                                              |
|                                                                                       | HP 2934A    | impact<br>(9x12, 36x24)       | 67, 200              | 136, 223                       | RS232C<br>(9.6K bps)                                     | 2,995(Q1)                     | bar code generation                                          |

## MATRIX CHARACTER PRINTERS

| Company                                                                   | Model | Print method<br>(matrix size)          | Print speed<br>(cps) | Characters/line                | Interfaces<br>(Transmission rate)                                     | Price \$<br>(quantity)    | Notes, features                                                         |
|---------------------------------------------------------------------------|-------|----------------------------------------|----------------------|--------------------------------|-----------------------------------------------------------------------|---------------------------|-------------------------------------------------------------------------|
| QuietJet Plus                                                             |       | ink jet<br>(19x12, 19x32)              | 40, 48,<br>160, 192  | 132, 158                       | RS232C, Centronics                                                    | 799(Q1)                   | noise level less than 48.5 dB(a)                                        |
| ThinkJet                                                                  |       | ink jet<br>(11x12)                     | 150                  | 80                             | RS232C, Centronics,<br>HP-IB, HP-IL                                   | 495(Q1)                   | dot-addressable graphics                                                |
| <b>HONEYWELL INFORMATION SYSTEMS INC.</b>                                 |       |                                        |                      |                                |                                                                       |                           | <b>Circle 585</b>                                                       |
| 200 Smith St., Waltham, MA 02154, (617) 895-3490                          |       |                                        |                      |                                |                                                                       |                           |                                                                         |
| PRU7175 Model 34                                                          |       | impact<br>(9x9, 18x60)                 | 45, 200              | 132, 158, 198, 220             | RS232C, RS422A<br>(9.6K bps)                                          | 2,450(Q1);<br>1,960(Q100) | graphics, bar codes                                                     |
| PRU7250 Model 46                                                          |       | impact<br>(11x9, 36x18)                | 70, 400, 480         | 136, 163, 204, 227             | RS232C, RS422A<br>(19.2K bps)                                         | 3,495(Q1);<br>2,796(Q100) | 7-color printing, graphics                                              |
| <b>HONEYWELL INFORMATION SYSTEMS ITALIA</b>                               |       |                                        |                      |                                |                                                                       |                           | <b>Circle 586</b>                                                       |
| 390 Fourth St., San Francisco, CA 94017, (415) 974-6116                   |       |                                        |                      |                                |                                                                       |                           |                                                                         |
| 4/21                                                                      |       | impact<br>(9x11, 18x36)                | 40, 200              | 136, 232                       | RS232C, Centronics<br>(9.6K bps)                                      | 849(Q1)                   | bit-mapped graphics,<br>plug-in interface                               |
| 4/66                                                                      |       | impact<br>(9x11, 9x36,<br>18x36)       | 75, 180, 480         | 136, 213,<br>programmable      | RS232C, RS422<br>(19.2K bps)                                          | 2,400(Q1)                 | color printing, bit-mapped<br>graphics, fanfold and<br>cut sheet feeder |
| 4/66P                                                                     |       | impact<br>(9x11, 9x36,<br>18x36)       | 75, 180, 480         | 136, 233,<br>programmable      | RS232C, RS422,<br>Centronics<br>(19.2K bps)                           | 2,995(Q1)                 | color printing, bit-mapped<br>graphics, plotter emulation               |
| <b>IBM CORP.</b>                                                          |       |                                        |                      |                                |                                                                       |                           | <b>Circle 587</b>                                                       |
| Old Orchard Rd., Armonk, NY 10504, (914) 765-1900                         |       |                                        |                      |                                |                                                                       |                           |                                                                         |
| 4202                                                                      |       | impact<br>(9x12)                       | 40, 100, 200         | 136,<br>programmable           | RS232C, Centronics<br>(9.6K bps)                                      | 799(Q1)                   | bit-mapped graphics,<br>8K-byte buffer                                  |
| 4210                                                                      |       | impact<br>(9 x 12, 9 x 24,<br>18 x 24) | 40, 100, 200         | 66, 220,<br>programmable       | twinax                                                                | 1,800(Q1)                 |                                                                         |
| 4224 Model 2C2                                                            |       | impact<br>(7x7, 7x13,<br>12x13)        | 100, 200, 400        | 132, 158, 198                  | IBM 43XX, 303X, 308XX,<br>309X, System/370,<br>3174/3274 Control Unit | 6,700(Q1)                 | color printing; bit-image,<br>vector graphics                           |
| <b>INFOSCRIBE INC.</b>                                                    |       |                                        |                      |                                |                                                                       |                           | <b>Circle 588</b>                                                       |
| 1808 Michael Faraday Court, Reston, VA 22090, (703) 689-2805              |       |                                        |                      |                                |                                                                       |                           |                                                                         |
| 800                                                                       |       | impact<br>(19x18)                      | 40, 200              | 136, 163, 224                  | RS232C, Centronics,<br>current loop<br>(9.6K bps)                     | 1,895(Q1);<br>1,137(Q100) | dot-addressable graphics,<br>ruggedized                                 |
| 1100                                                                      |       | impact<br>(19x18)                      | 40, 200              | 136, 163, 224                  | RS232C, Centronics,<br>current loop<br>(9.6K bps)                     | 1,490(Q1);<br>894(Q100)   | dot-addressable graphics,<br>ruggedized                                 |
| 1400                                                                      |       | impact<br>(24x18)                      | 80, 400              | 136, 163, 224,<br>programmable | parallel<br>(9.6K bps)                                                | 1,845(Q1);<br>1,107(Q100) | dot-addressable graphics,<br>ruggedized                                 |
| <b>JDL INC.</b>                                                           |       |                                        |                      |                                |                                                                       |                           | <b>Circle 589</b>                                                       |
| 2801 Townsgate Rd., Suite 104, Westlake Village, CA 91361, (805) 495-3451 |       |                                        |                      |                                |                                                                       |                           |                                                                         |
| 850 EWS                                                                   |       | impact<br>(12x24, 36x24)               | 144, 360             | 136, 163, 232, 272             | RS232C, Centronics<br>(600-19.2K bps)                                 | 2,495(Q1)                 | 14-color printing, graphics,<br>plotter emulation                       |
| 850 EWS/GL                                                                |       | impact<br>(12x24, 36x24)               | 144, 360             | 136, 163, 232, 272             | RS232C, Centronics<br>(600-19.2K bps)                                 | 3,495(Q1)                 | 14-color printing, graphics, plotter<br>emulation, HP-GL compatible     |
| <b>MANNESMANN TALLY CORP.</b>                                             |       |                                        |                      |                                |                                                                       |                           | <b>Circle 590</b>                                                       |
| 8301 S. 180th St., Kent, WA 98032, (206) 251-5500                         |       |                                        |                      |                                |                                                                       |                           |                                                                         |
| MT87                                                                      |       | impact<br>(24x18)                      | 200                  |                                | RS232C, Centronics, Apple<br>serial (9.6K bps)                        | 599(Q1)                   | dot-addressable graphics                                                |
| MT290                                                                     |       | impact<br>(40x18)                      | 200                  | 132, 154, 218, 264             | RS232C, current loop, IEEE<br>(9.6K bps)                              | 1,099(Q1)                 | dot-addressable graphics                                                |
| MT490                                                                     |       | impact<br>(48x18)                      | 400                  | 132, 158, 198, 225             | RS232C, Centronics<br>(9.6K bps)                                      | 2,549(Q1)                 | color printing, dot-addressable<br>graphics                             |
| <b>MODULAR COMPUTER SYSTEMS INC. (MODCOMP)</b>                            |       |                                        |                      |                                |                                                                       |                           | <b>Circle 591</b>                                                       |
| 1650 W. McNab Rd., Fort Lauderdale, FL 33310, (305) 977-1823              |       |                                        |                      |                                |                                                                       |                           |                                                                         |
| 4228                                                                      |       | impact<br>(9x7)                        | 150                  | 132                            | RS232C<br>(110-9.6K bps)                                              | 4,140(Q1)<br>3,519(Q100)  |                                                                         |
| 4856                                                                      |       | impact<br>(9x7)                        | 150                  | 132                            | parallel DMP                                                          | 4,400(Q1);<br>3,740(Q100) |                                                                         |
| <b>NCR CORP.</b>                                                          |       |                                        |                      |                                |                                                                       |                           | <b>Circle 592</b>                                                       |
| 1700 S. Patterson Blvd., Dayton, OH 45479, (513) 445-4000                 |       |                                        |                      |                                |                                                                       |                           |                                                                         |
| 6411                                                                      |       | impact                                 | 180                  | 80, 136                        | RS232C, Centronics<br>(19.2K bps)                                     | 795(Q1)                   | color printing, bit-mapped graphics                                     |
| 6444                                                                      |       | impact                                 | 400                  | 136,<br>programmable           | RS232C, Centronics<br>(19.2K bps)                                     | 2,695(Q1)                 | bit-mapped graphics                                                     |



# Workaholics

## THE GENICOM 3000 SERIES

Printers that don't know  
when to quit

Business success demands hard work. That's why more and more businesses depend on the Genicom 3000 series. Six hardworking, reliable printers that make life easier.

**You name it.  
The 3000s can handle it.**

No matter what you need in a rugged business printer—3000's your number. Just look at these job qualifications. Data processing printing at a blazing 400 cps. Letter quality at an unmatched 180 cps. And reliable paper handling for even the most demanding applications.



Need a trained specialist? The 3000s are ready. With extra quiet printers that

crank the work out at under 55 dBA. Printers with seven color capability for presentation quality business graphics. Even printers for bar codes.



Best of all, there's a 3000 series printer built specifically for your office. For dependable printing with everything from a single PC to a multi-terminal information system.

**Real team players.**

The 3000 series printers make fast friends with their co-workers. Because they're compatible with any computer worth mentioning. And software packages like Lotus 1-2-3<sup>®</sup>, Symphony<sup>®</sup> and WordStar<sup>®</sup>.

So, don't waste time with a clockwatching printer. Hire one of the workaholics. A Genicom 3000 series printer. For more information, contact your nearby Genicom dealer.

Or call 1-800-437-7468.  
In Virginia, call  
1-703-949-1170.

Lotus 1-2-3 and Symphony are registered trademarks of Lotus Development Corporation. WordStar is a registered trademark of MicroPro International.

# GENICOM

The Printers That Mean Business.

Genicom Drive, Waynesboro, VA 22980

CIRCLE NO. 79 ON INQUIRY CARD

## MATRIX CHARACTER PRINTERS

| Company                                                                               | Model              | Print method<br>(matrix size) | Print speed<br>(cps) | Characters/line                                | Interfaces<br>(Transmission rate)                             | Price \$<br>(quantity)   | Notes, features                                      |
|---------------------------------------------------------------------------------------|--------------------|-------------------------------|----------------------|------------------------------------------------|---------------------------------------------------------------|--------------------------|------------------------------------------------------|
| <b>NEC INFORMATION SYSTEMS INC.</b> <span style="float: right;">Circle 593</span>     |                    |                               |                      |                                                |                                                               |                          |                                                      |
| 1414 Massachusetts Ave., Boxborough, MA 01721, (617) 264-8000                         |                    |                               |                      |                                                |                                                               |                          |                                                      |
|                                                                                       | P5XL               | impact<br>(24x36)             | 100, 290             | 132-272                                        | RS232C, Centronics,<br>Diablo, Epson<br>(9.6K bps)            | 1,495(Q1)                | color printing, graphics                             |
|                                                                                       | P6                 | impact<br>(24x36)             | 65, 216              | 80-160                                         | RS232C, Centronics,<br>Epson (9.6K bps)                       | 699(Q1)                  | graphics                                             |
|                                                                                       | P9XL               | impact<br>(24x36)             | 140, 400             | 132-272                                        | RS232C, Centronics,<br>Diablo, Epson<br>(9.6K bps)            | 1,795(Q1)                | graphics                                             |
| <b>NEWBURY DATA INC.</b> <span style="float: right;">Circle 657</span>                |                    |                               |                      |                                                |                                                               |                          |                                                      |
| 2200 Pacific Coast Highway, Suite 208, Hermosa Beach, CA 90254, (213) 372-3775        |                    |                               |                      |                                                |                                                               |                          |                                                      |
|                                                                                       | OSP 1              | impact<br>(9x8, 9x5)          | 110, 180             | 1-226,<br>programmable                         | Centronics<br>(9.6K bps)                                      | 1,330(Q1);<br>770(Q1000) |                                                      |
|                                                                                       | OSP 2              | impact<br>(12x10, 12x20)      | 100, 200             | 1-226,<br>programmable                         | Centronics<br>(9.6K bps)                                      | 1,420(Q1);<br>822(Q1000) |                                                      |
|                                                                                       | OSP 3              | impact<br>(12x20)             | 50, 100, 200         | 1-226,<br>programmable                         | Centronics<br>(9.6K bps)                                      | 1,690(Q1);<br>980(Q1000) |                                                      |
| <b>NISSHO INFORMATION SYSTEMS CORP.</b> <span style="float: right;">Circle 594</span> |                    |                               |                      |                                                |                                                               |                          |                                                      |
| 10855 Business Center Dr., Suite 100, Cypress, CA 90630, (714) 952-8700               |                    |                               |                      |                                                |                                                               |                          |                                                      |
|                                                                                       | NP-910             | impact<br>(9x12, 17x24)       | 58, 350              | 132-237                                        | RS232C, Centronics,<br>coax, twinax<br>(up to 19.2K bps)      | 1,445(Q1)                | bit-mapped graphics, plug-in<br>cartridge interfaces |
|                                                                                       | NP-2410            | impact<br>(24x18, 24x36)      | 150-225,<br>300-540  | 132-237                                        | RS232C, Centronics<br>(up to 19.2K bps)                       | 1,845(Q1)                | bit-mapped graphics, plug-in<br>cartridge interfaces |
| <b>OKIDATA</b> <span style="float: right;">Circle 595</span>                          |                    |                               |                      |                                                |                                                               |                          |                                                      |
| 532 Fellowship Rd., Mt. Laurel, NJ 08054, (609) 235-2600                              |                    |                               |                      |                                                |                                                               |                          |                                                      |
|                                                                                       | Microline 193 Plus | impact<br>(9x9, 17x17)        | 38, 180              | 136, 163, 233                                  | RS232C, RS422<br>(up to 19.2K bps)                            | 749(Q1)                  | bit-image graphics                                   |
|                                                                                       | Microline 293      | impact<br>(9x9, 17x17)        | 100, 200             | 136, 163, 233                                  | RS232C, RS422, parallel<br>(up to 19.2K bps)                  | 949(Q1)                  | 14-color printing, bit-image<br>graphics             |
|                                                                                       | Microline 294      | impact<br>(9x9, 17x17)        | 100, 400             | 136, 163, 233,<br>programmable                 | RS232C, RS422, parallel<br>(up to 19.2K bps)                  | 1,499(Q1)                | 14-color printing, bit-image<br>graphics             |
| <b>OLYMPIA USA INC.</b> <span style="float: right;">Circle 596</span>                 |                    |                               |                      |                                                |                                                               |                          |                                                      |
| P.O. Box 22, Somerville, NJ 08876, (201) 722-7000                                     |                    |                               |                      |                                                |                                                               |                          |                                                      |
|                                                                                       | NP 80              | impact<br>(9x9)               | 200                  | 40, 48, 68, 80,<br>96, 137                     | Centronics<br>(9.6K bps)                                      | 499(Q1)                  | graphics, 7K-byte buffer                             |
|                                                                                       | NP 136             | impact<br>(9x9)               | 200                  | 81, 136, 163, 233                              | Centronics<br>(9.6K bps)                                      | 649(Q1)                  | graphics, 7K-byte buffer                             |
| <b>OUTPUT TECHNOLOGY CORP.</b> <span style="float: right;">Circle 597</span>          |                    |                               |                      |                                                |                                                               |                          |                                                      |
| E. 9922 Montgomery, Spokane, WA 99206, (509) 926-3855                                 |                    |                               |                      |                                                |                                                               |                          |                                                      |
|                                                                                       | OT-700n            | impact<br>(9x7)               | 700                  | 68, 81, 113, 136,<br>163, 226,<br>programmable | RS232C, Centronics<br>(up to 9.6K bps)                        |                          | dot-addressable graphics,<br>bar codes               |
|                                                                                       | OT-850XL           | impact<br>(9x7)               | 850                  | 68, 81, 113, 136,<br>163, 226, 247             | RS232C, Centronics<br>(up to 19.2K bps)                       | 2,395(Q1)                | graphics, bar codes                                  |
|                                                                                       | OT-880XL           | impact<br>(9x7)               | 850                  | 68, 81, 113, 136,<br>163, 226, 247             | twinax, parallel                                              | 3,795(Q1)                | graphics, bar codes, 3 heads                         |
| <b>PERSONAL MICRO COMPUTERS INC.</b> <span style="float: right;">Circle 598</span>    |                    |                               |                      |                                                |                                                               |                          |                                                      |
| 275 Santa Ana Court, Sunnyvale, CA 94086, (408) 737-8444                              |                    |                               |                      |                                                |                                                               |                          |                                                      |
|                                                                                       | DMP-85             | impact<br>(7x9)               | 120                  | 80, 96, 137,<br>programmable                   | Centronics                                                    | 295(Q1)                  | proportional print, bit-mapped<br>graphics           |
| <b>PRINTEK INC.</b> <span style="float: right;">Circle 599</span>                     |                    |                               |                      |                                                |                                                               |                          |                                                      |
| 1517 Townline Rd., Benton Harbor, MI 49022, (616) 925-3200                            |                    |                               |                      |                                                |                                                               |                          |                                                      |
|                                                                                       | 910                | impact<br>(9x9, 24x18)        | 200                  | up to 227                                      | RS232C, Centronics<br>(9.6K bps)                              | 1,595(Q1)                | dot-addressable graphics                             |
|                                                                                       | 920                | impact<br>(9x9, 24x18)        | 340                  | up to 227                                      | RS232C, Centronics<br>(9.6K bps)                              | 2,395(Q1)                | dot-addressable graphics                             |
|                                                                                       | FormsPro 2000      | impact<br>(9x9, 24x18)        | 200                  | up to 227                                      | RS232C, Centronics<br>(9.6K bps)                              | 2,095(Q1)                | dot-addressable graphics                             |
| <b>PRINTRONIX INC.</b> <span style="float: right;">Circle 600</span>                  |                    |                               |                      |                                                |                                                               |                          |                                                      |
| 17500 Cartwright Rd., Irvine, CA 92714, (714) 863-1900                                |                    |                               |                      |                                                |                                                               |                          |                                                      |
|                                                                                       | S7024              | impact<br>(7x9)               | 240                  | 68, 81, 136,<br>163, 232,<br>programmable      | RS232C, Centronics,<br>IBM 3270, 5225<br>(9.6K bps)           | 1,365(Q1)                | color printing, bit-mapped graphics                  |
| <b>SINGER DATA PRODUCTS</b> <span style="float: right;">Circle 601</span>             |                    |                               |                      |                                                |                                                               |                          |                                                      |
| 790 Maple Lane, Bensenville, IL 60106, (312) 860-6500                                 |                    |                               |                      |                                                |                                                               |                          |                                                      |
|                                                                                       | 612                | impact<br>(18x36)             | 400                  | 132, 158, 198, 237,<br>programmable            | RS232C, Centronics,<br>current loop, Diablo<br>(150-9.6K bps) | less than 1,700(Q1)      | bit-mapped graphics                                  |

## MATRIX CHARACTER PRINTERS

| Company                                                       | Model | Print method<br>(matrix size) | Print speed<br>(cps)  | Characters/line                                 | Interfaces<br>(Transmission rate)                              | Price \$<br>(quantity)    | Notes, features                                                  |
|---------------------------------------------------------------|-------|-------------------------------|-----------------------|-------------------------------------------------|----------------------------------------------------------------|---------------------------|------------------------------------------------------------------|
| 615                                                           |       | impact<br>(18x36)             | 400                   | 132, 158, 198, 237,<br>programmable             | RS232C, Centronics,<br>current loop, Diablo<br>(150-9.6K bps)  | less than 1,700(Q1)       | color printing, bit-mapped<br>graphics                           |
| PC                                                            |       | impact<br>(18x36)             | 400                   | 132, 158, 198, 237,<br>programmable             | RS232C, Centronics,<br>current loop, Diablo<br>(150-9.6K bps)  | less than 1,700(Q1)       | color printing, bit-mapped<br>graphics                           |
| <b>STAR MICRONICS AMERICA INC.</b>                            |       |                               |                       |                                                 |                                                                |                           |                                                                  |
| 200 Park Ave., Suite 3510, New York, NY 10166, (212) 986-6770 |       |                               |                       |                                                 |                                                                |                           |                                                                  |
| <b>Circle 602</b>                                             |       |                               |                       |                                                 |                                                                |                           |                                                                  |
| NB-15                                                         |       | impact<br>(24x13, 24x15)      | 100, 300              |                                                 | Centronics                                                     | 1,449(Q1)                 |                                                                  |
| NB24-15                                                       |       | impact<br>(24x27, 24x31)      | 60, 180               |                                                 | Centronics                                                     | 1,099(Q1)                 |                                                                  |
| <b>SYNTEST CORP.</b>                                          |       |                               |                       |                                                 |                                                                |                           |                                                                  |
| 40 Locke Dr., Marlboro, MA 01752, (617) 481-7827              |       |                               |                       |                                                 |                                                                |                           |                                                                  |
| <b>Circle 603</b>                                             |       |                               |                       |                                                 |                                                                |                           |                                                                  |
| SP-2010                                                       |       | impact<br>(5x9)               | 130                   | 80                                              | RS232C, Centronics<br>(110-9.6K bps)                           | 1,035(Q1)                 | rackmount, ruggedized                                            |
| <b>TANDY CORP. (RADIO SHACK)</b>                              |       |                               |                       |                                                 |                                                                |                           |                                                                  |
| 1800 One Tandy Center, Fort Worth, TX 76102, (817) 390-3011   |       |                               |                       |                                                 |                                                                |                           |                                                                  |
| <b>Circle 604</b>                                             |       |                               |                       |                                                 |                                                                |                           |                                                                  |
| DMP 130                                                       |       | impact<br>(9x9, 18x18)        | 100                   | 80, 132,<br>programmable                        | Centronics<br>(600 to 2.4K bps)                                | 349(Q1)                   | graphics                                                         |
| DMP 430                                                       |       | impact                        | 180                   | 80, 132                                         | Centronics<br>(600 to 2.4K bps)                                | 699(Q1)                   | graphics                                                         |
| DMP 2110                                                      |       | impact                        | 240                   | 80, 132                                         | Centronics                                                     | 1,295(Q1)                 | graphics                                                         |
| <b>TELEX COMPUTER PRODUCTS INC.</b>                           |       |                               |                       |                                                 |                                                                |                           |                                                                  |
| 6422 E. 41st St., Tulsa, OK 74135, (918) 627-1111             |       |                               |                       |                                                 |                                                                |                           |                                                                  |
| <b>Circle 605</b>                                             |       |                               |                       |                                                 |                                                                |                           |                                                                  |
| 214XP                                                         |       | impact<br>(9x9, 18x24)        | 100, 400              | 136, 220                                        | twi-nax                                                        | 5,100(Q1)                 | label printing applications                                      |
| <b>TEXAS INSTRUMENTS INC.</b>                                 |       |                               |                       |                                                 |                                                                |                           |                                                                  |
| P.O. Box 809063, Dallas, TX 75380-9063, (800) 527-3500        |       |                               |                       |                                                 |                                                                |                           |                                                                  |
| <b>Circle 606</b>                                             |       |                               |                       |                                                 |                                                                |                           |                                                                  |
| 850XL                                                         |       | impact<br>(9x9, 15x18)        | 35, 150               | 80, 134                                         | RS232C, RS422,<br>RS488, parallel<br>(200-9.6K bps)            |                           | bit-mapped graphics, bidirectional<br>printing, 256K-byte buffer |
| 855                                                           |       | impact<br>(9x9, 32x18)        | 35, 150               | 80, 134                                         | RS232C, RS422,<br>RS488, parallel<br>(300-9.6K bps)            |                           | bit-mapped graphics, 256K-byte<br>buffer, dual mode              |
| 860XL                                                         |       | impact<br>(9x9, 15x18)        | 35, 150               | 136, 272                                        | RS232C, parallel                                               |                           | bit-mapped graphics,<br>wide-carriage version of 850XL           |
| <b>TOSHIBA AMERICA INC.</b>                                   |       |                               |                       |                                                 |                                                                |                           |                                                                  |
| 2441 Michelle Dr., Tustin, CA 92680, (714) 730-5000           |       |                               |                       |                                                 |                                                                |                           |                                                                  |
| <b>Circle 607</b>                                             |       |                               |                       |                                                 |                                                                |                           |                                                                  |
| P321                                                          |       | impact<br>(24x36)             | 72, 216               | 80, 132                                         | RS232C, Centronics<br>(19.2K bps)                              | 699(Q1)                   | graphics                                                         |
| P341                                                          |       | impact<br>(24x36)             | 72, 216               | 136, 226                                        | RS232C, Centronics<br>(19.2K bps)                              | 1,099(Q1)                 | graphics                                                         |
| P351 Model 2                                                  |       | impact<br>(24x36)             | 100, 300              | 136, 226                                        | RS232C, Centronics<br>(19.2K bps)                              | 1,599(Q1)                 | color printing, graphics                                         |
| <b>WANG LABORATORIES INC.</b>                                 |       |                               |                       |                                                 |                                                                |                           |                                                                  |
| One Industrial Ave., Lowell, MA 01851, (617) 459-5000         |       |                               |                       |                                                 |                                                                |                           |                                                                  |
| <b>Circle 608</b>                                             |       |                               |                       |                                                 |                                                                |                           |                                                                  |
| VS-PM017                                                      |       | impact                        | 400                   | 132                                             | RS232C<br>(9.6K bps)                                           | 2,100(Q1)                 | noise level less than 55 dB(a)                                   |
| VS-PM019                                                      |       | impact                        | 200                   | 132                                             | RS232C<br>(9.6K bps)                                           | 1,395(Q1)                 |                                                                  |
| <b>WENGER PRINTERS AG</b>                                     |       |                               |                       |                                                 |                                                                |                           |                                                                  |
| Im Kagen 23/25, CH-4153 Reinach, Switzerland, (061) 76 87 87  |       |                               |                       |                                                 |                                                                |                           |                                                                  |
| <b>Circle 609</b>                                             |       |                               |                       |                                                 |                                                                |                           |                                                                  |
| Wenger 1/1                                                    |       | impact<br>(9x12, 18x36)       | 30, 160               | 40, 48, 60, 68, 80,<br>96, 120, 137             | RS232C, RS422A,<br>Centronics, current loop<br>(110-19.2K bps) |                           | bit-image graphics, noise level<br>less than 48 dB(a)            |
| Wenger 3/1                                                    |       | impact<br>(9x12, 18x36)       | 75, 400               | 66, 80, 100, 112,<br>132, 158, 198,<br>220, 226 | RS232C, RS422,<br>Centronics<br>(300-19.2K bps)                |                           | color printing, bit-image graphics                               |
| Wenger 4/1                                                    |       | impact<br>(9x12, 18x36)       | 100, 130, 400,<br>600 | 66-300                                          | RS232C, RS422,<br>Centronics, current loop<br>(50-19.2K bps)   |                           | color printing, bit-image graphics                               |
| <b>XEROX CORP. (BUSINESS SYSTEMS GROUP)</b>                   |       |                               |                       |                                                 |                                                                |                           |                                                                  |
| P.O. Box 24, Rochester, NY 14692, (800) 334-6200              |       |                               |                       |                                                 |                                                                |                           |                                                                  |
| <b>Circle 610</b>                                             |       |                               |                       |                                                 |                                                                |                           |                                                                  |
| Companion 34LQ                                                |       | impact<br>(9x11, 18x60)       | 60, 270               | 132, 226                                        | RS232C, RS422A,<br>Centronics<br>(1.2K to 9.6K bps)            | 1,399(Q1);<br>1,119(Q100) | bit-mapped graphics                                              |



# Japan Electronics: A Business and Technology Update

The Japan Electronics seminar on October 7 in Osaka is designed to help European and U.S. executives seek out new business opportunities in Japan. The day-long seminar, which will coincide with the Japan Electronics Show, has been structured to provide attendees with a statistical overview of the Japanese electronics industry, as well as a preview of upcoming technological trends.

The seminar is intended both as an introduction to Japan for first-time visitors as well as an update of Japanese business and technology for seasoned travelers in the Far East. If you buy from, compete with, or sell to Japanese electronics companies, this seminar is for you.

**DATE:**  
October 7, 1987  
In conjunction with the  
Japan Electronics Show

**LOCATION:**  
Royal Hotel,  
Osaka, Japan

**SEMINAR FEE:**  
\$350

**OFFICIAL  
LANGUAGE:**  
English

**CO-SPONSORS:**  
AEA and  
Electronic Business

**In cooperation with:**  
RAI Gebouw bv of Holland  
U.S. Electronics Industry  
Japan Office  
Japan Electronics Show  
Association  
Osaka Chamber of  
Commerce and Industry  
EDN magazine  
Elektronika of Holland  
Plesman Publications of  
Canada

## CONFIRMED SPEAKERS:

**Kaoro Kubo**, vice president and general manager of NTT International. "The Japanese telecommunications industry: Opportunities for foreign suppliers"

**Kazuhiko Kobayashi**, manager of the Systems Engineering Division of Hitachi Ltd. "Factory automation in the Japanese computer industry"

**Hiroshi Komiya**, head of the Saijou Works, Mitsubishi Electric Corp. "Manufacturing technology in the semiconductor industry"

**Bill Totten**, president of Ashisuto K.K. "The Japanese market for U.S. and European software"

**David H. Johnson**, senior manager for Network Systems Sales, AT&T International. "Opportunities for U.S. communications manufacturers in Japan"

**Dinker Bir**, vice president of technology at Northern Telecom Japan Inc. "Trends in telecommunications"

**Pat O'Malley**, strategic marketing director for the Semiconductor Sector at Nippon Motorola Ltd. "The Japanese semiconductor market"

**Gen Narui**, regional manager for Educational Services at Nihon Digital Equipment Corp. "Recent developments in artificial intelligence at DEC"

**Stephen Donovan**, representative director of Monolithic Memories K.K. "Selling niche products in Japan"

**Shohei Kurita**, Tokyo editor for Electronic Business, author. "The Fifth Generation Computer Project"

**Gene Norrett**, vice president and director of the Semiconductor Industry Group, Dataquest Inc. "Electronics trends among countries on the Pacific Rim"

**Alberto Socolovsky**, associate publisher and editorial director of Electronic Business. "Structural differences between the U.S. and Japanese electronics industries"

Speaking on "Trends in consumer electronics":

**Nobuyoshi Yokobori**, manager of the R&D Planning Office, Corporate Engineering Division, Matsushita Electric Industrial Co. Ltd.

**Masaru Yamano**, executive vice president, Sanyo Electric Co. Ltd.

**Tadashi Sasaki**, corporate management advisor, Sharp Corp.

**Nobuo Tateishi**, executive vice president, Omron Tateishi Electronics Corp.

## REGISTRATION FORM

NAME \_\_\_\_\_

COMPANY \_\_\_\_\_

ADDRESS \_\_\_\_\_

CITY \_\_\_\_\_ STATE \_\_\_\_\_ ZIP \_\_\_\_\_

TEL \_\_\_\_\_ TELEX \_\_\_\_\_ FAX \_\_\_\_\_

NUMBER TO ATTEND \_\_\_\_\_

PAYMENT ENCLOSED

## Please return your registration to:

**IN U.S.A.:**  
Ms. Florence Lewis  
American Electronics Assoc.  
5201 Great American Parkway  
Santa Clara, Calif. 95054  
Tel: (408) 987-4200

**IN CANADA:**  
Ms. Sharon Raspin  
Plesman Publications  
2 Lansing Square, #703  
Willowdale, ON. M2J 5A1  
Tel: (416) 497-9562

**IN JAPAN:**  
Mr. Steve Weiner  
U.S. Electronics Office  
Kioicho Nanbu Bldg., 3F  
3-3 Kioicho,  
Chiyoda-Ku, Tokyo  
Tel: (03) 237-7195

**IN HOLLAND:**  
Nippon Express Nederland bv  
Parnassutoren Locatellikada 1  
1076 AZ Amsterdam  
Tel: (020) 79 27 77

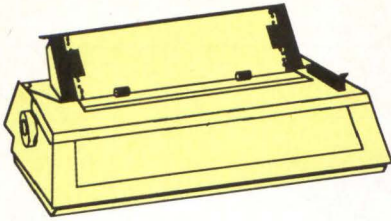

# IMPACT LINE PRINTERS

| Company                                                                                                | Model        | Print speed (lpm) | Characters per line                   | Forms width (inches) | Interfaces (Transmission rate)                                       | Price \$ (quantity)    | Notes, features                                  |
|--------------------------------------------------------------------------------------------------------|--------------|-------------------|---------------------------------------|----------------------|----------------------------------------------------------------------|------------------------|--------------------------------------------------|
| <b>CIE TERMINALS INC.</b> <span style="float: right;">Circle 551</span>                                |              |                   |                                       |                      |                                                                      |                        |                                                  |
| 2505 McCabe Way, Irvine, CA 92714, (714) 660-1421                                                      |              |                   |                                       |                      |                                                                      |                        |                                                  |
| CI-300+                                                                                                | 85-300       |                   | 266, programmable                     | 3.5-16               | RS232C, Centronics, Dataproducts (19.2K bps)                         | 4,495(Q1)              | bar codes, dual microprocessors with RAM and ROM |
| CI-600+                                                                                                | 170-600      |                   | 266, programmable                     | 3.5-16               | RS232C, Centronics, Dataproducts (19.2K bps)                         | 6,795(Q1)              | bar codes, dual microprocessors with RAM and ROM |
| <b>DATAPRODUCTS CORP.</b> <span style="float: right;">Circle 552</span>                                |              |                   |                                       |                      |                                                                      |                        |                                                  |
| 6200 Canoga Ave., Woodland Hills, CA 91365, (818) 887-8000                                             |              |                   |                                       |                      |                                                                      |                        |                                                  |
| B-300/600/1000                                                                                         | 300/650/1025 |                   | 132, 136                              |                      | RS232C, RS422, Centronics, Dataproducts (19.2K bps)                  | 6,143/8,642/12,936(Q1) |                                                  |
| BP-1500/2000                                                                                           | 1500/2000    |                   | 132, 136                              | 3.5-18.75            | RS232C, Centronics, Dataproducts (19.2K bps)                         | 22,700/30,390(Q1)      | acoustic cabinet                                 |
| LB-300/615                                                                                             | 330/650      |                   | 136                                   | 3-16                 | RS232C, Centronics, Dataproducts (19.2K bps)                         | 5,495/6,795(Q1)        | direct access VFU, universal power supply        |
| <b>DECISION DATA COMPUTER CORP.</b> <span style="float: right;">Circle 553</span>                      |              |                   |                                       |                      |                                                                      |                        |                                                  |
| 400 Horsham Rd., Horsham, PA 19044, (215) 757-3322, (800) 523-6529                                     |              |                   |                                       |                      |                                                                      |                        |                                                  |
| 6706                                                                                                   | 600          |                   | 132, 198                              | 4-16                 | twinax                                                               | 11,250(Q1)             | bit-mapped graphics                              |
| 6807                                                                                                   | 700          |                   | 132                                   | 3.5-17.5             | twinax                                                               | 11,450(Q1)             |                                                  |
| <b>DIGITAL EQUIPMENT CORP.</b> <span style="float: right;">Circle 554</span>                           |              |                   |                                       |                      |                                                                      |                        |                                                  |
| 200 Baker Ave., West Concord, MA 01742, (617) 264-1111                                                 |              |                   |                                       |                      |                                                                      |                        |                                                  |
| LG01                                                                                                   | 600          |                   |                                       | 4-16                 | RS232C, Dataproducts (1200 to 19.2K bps)                             | 11,950(Q1)             |                                                  |
| LG02                                                                                                   | 600          |                   |                                       | 4-16                 | RS232C, Dataproducts (1200 to 19.2K bps)                             | 14,000(Q1)             | graphics                                         |
| LP27                                                                                                   | 1200         |                   | 132                                   | 3.5-18               | Dataproducts                                                         | 29,000-33,000(Q1)      |                                                  |
| <b>GENERAL BUSINESS TECHNOLOGY INC.</b> <span style="float: right;">Circle 555</span>                  |              |                   |                                       |                      |                                                                      |                        |                                                  |
| 1891 McGaw Ave., Irvine, CA 92714, (714) 261-1891                                                      |              |                   |                                       |                      |                                                                      |                        |                                                  |
| 3320LP                                                                                                 | 900          |                   | 132                                   | 4-18                 | twinax                                                               | 12,500(Q1)             | acoustic cabinet                                 |
| 5240                                                                                                   | 300          |                   | 198                                   | 3.5-16               | twinax                                                               | 7,195(Q1)              |                                                  |
| 5241                                                                                                   | 600          |                   | 198                                   | 3.5-16               | twinax                                                               | 9,595(Q1)              |                                                  |
| <b>GENICOM CORP.</b> <span style="float: right;">Circle 556</span>                                     |              |                   |                                       |                      |                                                                      |                        |                                                  |
| Genicom Dr., Waynesboro, VA 22980, (703) 949-1000                                                      |              |                   |                                       |                      |                                                                      |                        |                                                  |
| 4410                                                                                                   | 400          |                   | 132, 158, 175, 198, 217, programmable | 3-16.54              | RS232C, Centronics, Dataproducts, Printronix (19.2K bps)             | 6,195(Q1)              | dot-addressable, block, line graphics            |
| 4440                                                                                                   | 800          |                   | 132, 158, 175, 198, 217, programmable | 3-16.54              | RS232C, Centronics, Dataproducts, Printronix (19.2K bps)             | 7,795(Q1)              | dot-addressable, block, line graphics            |
| 4500 Series                                                                                            | 400, 800     |                   | 132, 158, 175, 198, 217, programmable | 3-16.54              | coax, twinax                                                         | 7,790-9,420(Q1)        | dot-addressable, block, line graphics            |
| <b>HETRA COMPUTER AND COMMUNICATIONS INDUSTRIES INC.</b> <span style="float: right;">Circle 557</span> |              |                   |                                       |                      |                                                                      |                        |                                                  |
| P.O. Box 9000, Sebastian, FL 32958, (305) 589-7331                                                     |              |                   |                                       |                      |                                                                      |                        |                                                  |
| 3106                                                                                                   | 6000         |                   | 132                                   | 3.5-19               | RS232C, Centronics, current loop, Dataproducts, IEEE 488 (19.2K bps) | 10,000(Q1)             |                                                  |
| 3300                                                                                                   | 1000         |                   | 132                                   | 3.5-19               | RS232C, Centronics, current loop, Dataproducts, IEEE 488 (19.2K bps) | 14,000(Q1)             |                                                  |

## IMPACT LINE PRINTERS

| Company                                                                                      | Model        | Print speed<br>(lpm) | Characters<br>per line                       | Forms width<br>(inches) | Interfaces<br>(Transmission rate)                                          | Price \$<br>(quantity)                    | Notes, features          |
|----------------------------------------------------------------------------------------------|--------------|----------------------|----------------------------------------------|-------------------------|----------------------------------------------------------------------------|-------------------------------------------|--------------------------|
| <b>HEWLETT-PACKARD CO. (BOISE DIV.)</b> <span style="float: right;">Circle 558</span>        |              |                      |                                              |                         |                                                                            |                                           |                          |
| 11311 Chinden Blvd., Boise, ID 83714, (208) 323-2297                                         |              |                      |                                              |                         |                                                                            |                                           |                          |
|                                                                                              | 2563B        | 300                  | 132-220                                      | 3-16.7                  | RS232C, RS422C,<br>Centronics,<br>Dataproducts,<br>IEEE 488<br>(19.2K bps) | 5,700(Q1);<br>4,731(Q100)                 | raster graphics          |
|                                                                                              | 2564B        | 600                  | 132-220                                      | 3-16.7                  | RS232C, RS422C,<br>Centronics,<br>Dataproducts,<br>IEEE 488<br>(19.2K bps) | 12,445(Q1);<br>10,080(Q100)               | raster graphics          |
|                                                                                              | 2567B        | 1200, 1600           | 132-220                                      | 3-18                    | RS232C, RS422C,<br>Centronics,<br>Dataproducts,<br>IEEE 488                | 28,050(Q1);<br>21,879(Q100)               | raster graphics          |
| <b>HONEYWELL INFORMATION SYSTEMS INC.</b> <span style="float: right;">Circle 559</span>      |              |                      |                                              |                         |                                                                            |                                           |                          |
| 200 Smith St., Waltham, MA 02154, (617) 895-6000                                             |              |                      |                                              |                         |                                                                            |                                           |                          |
|                                                                                              | PRU9901/9902 | 300/600              | 132/136                                      | 3-15                    | DPS 6                                                                      | 11,500-14,450(Q1);<br>8,050-11,115(Q100)  |                          |
|                                                                                              | PRU9903/9904 | 900/1200             | 136                                          | 4-19                    | DPS 6                                                                      | 26,000-33,000(Q1);<br>18,200-23,100(Q100) |                          |
| <b>IBM CORP.</b> <span style="float: right;">Circle 656</span>                               |              |                      |                                              |                         |                                                                            |                                           |                          |
| Old Orchard Rd., Armonk, NY 10504, (914) 765-1900                                            |              |                      |                                              |                         |                                                                            |                                           |                          |
|                                                                                              | 4234 Model 2 | 120, 300, 400        |                                              | 3.5-16                  | twinax                                                                     | 8,800(Q1)                                 |                          |
|                                                                                              | 4245-T20     | 2000                 |                                              | 3.5-22                  | twinax                                                                     | 35,000(Q1)                                |                          |
|                                                                                              | 5262         | 650                  |                                              | 3.5-16                  | twinax                                                                     | 13,500(Q1)                                |                          |
| <b>MANNESMANN TALLY CORP.</b> <span style="float: right;">Circle 560</span>                  |              |                      |                                              |                         |                                                                            |                                           |                          |
| 8301 S. 180th St., Kent, WA 98032, (206) 251-5500                                            |              |                      |                                              |                         |                                                                            |                                           |                          |
|                                                                                              | MT660        | 600                  | 80, 100, 120, 132, 150, 198,<br>programmable | 4-16                    | RS232C, RS422,<br>Centronics, current<br>loop, Dataproducts                | 8,490(Q1)                                 | dot-addressable graphics |
|                                                                                              | MT690        | 900                  | 80, 100, 120, 132, 150, 198,<br>programmable | 4-16                    | RS232C, RS422,<br>Centronics, current<br>loop, Dataproducts                | 10,500(Q1)                                | dot-addressable graphics |
| <b>MODULAR COMPUTER SYSTEMS INC. (MODCOMP)</b> <span style="float: right;">Circle 561</span> |              |                      |                                              |                         |                                                                            |                                           |                          |
| 1650 W. McNab Rd., Fort Lauderdale, FL 33310, (305) 974-1380                                 |              |                      |                                              |                         |                                                                            |                                           |                          |
|                                                                                              | 4240         | 300                  | 132                                          | 16                      | Dataproducts                                                               | 8,600(Q1);<br>6,885(Q100)                 |                          |
|                                                                                              | 4241         | 600                  | 132                                          | 16                      | Dataproducts                                                               | 10,250(Q1);<br>8,713(Q100)                |                          |
|                                                                                              | 4242         | 1000                 | 132                                          | 16                      | Dataproducts                                                               | 15,875(Q1);<br>13,494(Q100)               | acoustic cabinet         |
| <b>PRINTRONIX INC.</b> <span style="float: right;">Circle 562</span>                         |              |                      |                                              |                         |                                                                            |                                           |                          |
| 17500 Cartwright Rd., Irvine, CA 92713, (714) 863-1900                                       |              |                      |                                              |                         |                                                                            |                                           |                          |
|                                                                                              | MV150B       | 200                  | 132, 165, 220                                | 3-16                    | Centronics;<br>Dataproducts; IBM<br>3287, 5225                             | 3,745(Q1)                                 | raster graphics          |
|                                                                                              | P1013        | 134                  | 80, 96                                       | 4.5-11, 2-10            | Centronics                                                                 | 795(Q1)                                   | dot-addressable graphics |
|                                                                                              | P6000 Series | 400, 800             | up to 256                                    | 3-16                    | RS323C; Centronics;<br>IBM 3203, 3287, 5225                                | 5,800-8,600(Q1)                           | graphics plot mode       |
| <b>STORAGE TECHNOLOGY CORP.</b> <span style="float: right;">Circle 563</span>                |              |                      |                                              |                         |                                                                            |                                           |                          |
| 2270 S. 88th St., MD-3N, Louisville, CO 80028, (303) 673-6543                                |              |                      |                                              |                         |                                                                            |                                           |                          |
|                                                                                              | 5000-050     | up to 5000           | 132                                          | 3.5-22.4                | Dataproducts,<br>IBM FIPS                                                  | 46,100(Q1)                                | dual hammer banks        |
| <b>TELEX COMPUTER PRODUCTS INC.</b> <span style="float: right;">Circle 564</span>            |              |                      |                                              |                         |                                                                            |                                           |                          |
| 6422 E. 41st St., Tulsa, OK 74135, (918) 627-1111                                            |              |                      |                                              |                         |                                                                            |                                           |                          |
|                                                                                              | 225          | 600, 800             | 132, 220                                     | 3-16                    | twinax                                                                     | 12,800(Q1)                                |                          |
| <b>WANG LABORATORIES INC.</b> <span style="float: right;">Circle 565</span>                  |              |                      |                                              |                         |                                                                            |                                           |                          |
| One Industrial Ave., Lowell, MA 01851, (617) 459-5000                                        |              |                      |                                              |                         |                                                                            |                                           |                          |
|                                                                                              | 5573         | 250                  | 132                                          | 16                      |                                                                            | 9,000(Q1)                                 |                          |
|                                                                                              | 5574-1       | 600                  | 132                                          | 16                      |                                                                            | 15,000(Q1)                                |                          |
|                                                                                              | 5575         | 1100                 | 136                                          | 16                      |                                                                            | 26,000(Q1)                                |                          |

# INTERPHASE PULLS A FAST ONE

## V/SMD 4200



# VMEbus

## V/ESDI 4201

### 30 MBytes/s on VMEbus

INTERPHASE® shatters the old speed limits of the VMEbus with its second generation of VME disk controllers boasting 30 megabytes per second bus speeds and above. Using a new INTERPHASE technology breakthrough called the BUSpacket Interface<sup>SM</sup>... the new V/SMD 4200 Cheetah and V/ESDI 4201 Panther triple existing VMEbus speeds and approach the VMEbus theoretical bandwidth of 40 megabytes per second!  
**SIMPLY THE FASTEST**

The combination of the BUSpacket Interface and a large (128 KBytes) cache memory provide the V/SMD 4200 and V/ESDI 4201 with unequalled speed, and make them the fastest SMD and ESDI controllers by a factor of three. No one even comes close!

In simple terms, the new INTERPHASE technology

preformats packets of data to go across the bus before acquiring it. The INTERPHASE BUSpacket approach unharnesses the VMEbus from slow devices through deep, high-speed bus FIFOs and an asynchronous delay line-based state machine, which controls bus transfers. Data is emptied onto the bus in packets at speeds 30 megabytes per second and above.

#### STICK WITH THE WINNERS

The V/SMD 4200 and V/ESDI 4201 also incorporate the proven INTERPHASE features of the multitasking Virtual Buffer Architecture<sup>SM</sup>, Intelligent Caching, and zero latency operation found on other popular INTERPHASE

products. The four drive V/ESDI 4201 Panther even adds an integral SCSI port for easy addition of back up devices.

Both products complement INTERPHASE's high-performance V/Tape 3209 1/2" tape controller, and are **PLUG & PLAY** software compatible with the industry's most successful SMD and ESDI controllers, our V/SMD 3200 and V/ESDI 3201.

#### THEY'RE GOING FAST

To learn more about the fastest SMD, ESDI and 1/2" tape controllers around, call or write today... but you better move fast... INTERPHASE certainly is.

(214) 350-9000



**INTERPHASE**  
corporation

2925 Merrell Road • Dallas, Texas 75229 • Telex: 9109976245 NASDAQ-NMS:INPH

Interphase International

93a New Street, Aylesbury, Bucks. HP20 2NY, England (0296)35661 Telex: 826715 AERO G

Interphase is a registered trademark of Interphase Corporation. BUSpacket Interface and Virtual Buffer Architecture, are service marks of Interphase Corporation.

CIRCLE NO. 93 ON INQUIRY CARD

# ADVERTISERS' INDEX

| COMPANY                               | PAGE NO.   | INQUIRY NO. | COMPANY                                   | PAGE NO.                 | INQUIRY NO.   |
|---------------------------------------|------------|-------------|-------------------------------------------|--------------------------|---------------|
| ADAC Corp.                            | 124        | 61          | Interphase Corp.                          | 171                      | 90            |
| ADDS                                  | 135, 137   | 65, 86      | Ioline Corp.                              | 175                      | 207           |
| Advanced Matrix Technology Inc.       | 144        | 90          | Irwin Magnetics                           | 102-103                  | 50            |
| Algo                                  | 176        | 216-218     | JDL                                       | 1                        | 2             |
| Altos Computer Systems                | 25, 26-27  | 17          | Kierulff Electronics                      | 112                      | 55            |
| Ampex                                 | 130        | 63          | KMW Systems Corp.                         | 76                       | 38            |
| Analog & Digital Peripherals          | 176        | 221         | LaPine Technology                         | 146                      | 75            |
| Bizcomp                               | 13         | 10          | Leasametric                               | 33-40                    | —             |
| BP Microsystems                       | 174        | 205         | L/F Technologies Inc.                     | 140                      | 69            |
| Bruning Computer Graphics             | 78         | 39          | Maxtor Corp.                              | 50                       | 26            |
| Cahners Exposition Group              | 111        | 54          | Microplot Systems                         | 116                      | 85            |
| Chinon America                        | 84         | 42          | Microware, Inc.                           | 175                      | 214           |
| Chrislin Industries, Inc.             | 12         | 9           | Motorola/Micro-Computer Div.              | 128-129                  | 78            |
| CIE Terminals                         | 16, 162    | 12, 80      | Multi-Tech                                | Cov. 3                   | 81            |
| Clearpoint                            | 47, 49, 51 | 23-25       | Mylex                                     | 53                       | 27            |
| Communications Research Group         | 176        | 219         | National Computer Graphics Association    | 173                      | 52            |
| Concurrent Computer                   | 90         | 46          | National Semiconductor Corp.              | 20-21                    | 14            |
| Conner Peripherals                    | 10-11      | 8           | NCR Corp.                                 | 42-43                    | 21            |
| Convergent Technologies               | 30-31      | 19          | NEC Information Systems Inc.              | 2-3, 62-63, 107, 118-119 | 3, 31, 74, 58 |
| CSSL                                  | 141        | 70          | Nissho Electronics                        | 22                       | 15            |
| CYB Systems                           | 6          | 5           | Omega                                     | 175                      | 208-211       |
| Data Access Corp.                     | 104        | 51          | Pioneer/Optical Memory Prods. Div.        | 15                       | 11            |
| Dataproductions                       | 150        | 77          | Quality Micro Systems                     | 74-75                    | —             |
| Datasouth Computer Corp.              | 148        | 76          | Qualogy Inc.                              | 101                      | 49            |
| Data Track                            | 174        | 201, 202    | Qualstar                                  | 175                      | 215           |
| Digi-Board                            | 136        | 66          | Radio Shack (Tandy Corp.)                 | 83                       | 41            |
| Digi-Data Corp.                       | 138        | 67          | Rainbow                                   | 86                       | 43            |
| Diversified Technology                | 12         | 29          | Right Soft                                | 174                      | 203           |
| Eikonix                               | 44         | 22          | Samsung Electron Devices                  | 28                       | 18            |
| Electronic Specialists                | 174        | 204         | Seagate Technology                        | 132-133                  | 87            |
| Equinox Systems                       | 8          | 7           | Seikosha                                  | 127                      | 62            |
| Facit Data Products                   | 115        | 56          | Sequel Data                               | 87                       | 44            |
| Flagstaff Engineering                 | 176        | 220         | Sigma Designs                             | 80                       | 40            |
| Ford                                  | 76A-76B    | —           | Softronics                                | 175                      | 212           |
| Fujitsu America Inc. Storage Division | 7          | 6           | Systech                                   | 67, 69, 71, 73           | 33-36         |
| Genicom                               | 165        | 79          | TEAC Corp.                                | 19                       | 13            |
| Gould Inc., Computer Systems Div.     | 139        | 68          | Technology Forums                         | 14                       | 73            |
| Grafpoint                             | 174        | 206         | Tektronix Inc.                            | 57-60                    | 30            |
| Hayes Microcomputer Products          | Cov. 2     | 1           | TeleVideo/Computer Div.                   | 88-89                    | 45            |
| Hewlett-Packard Co.                   | 120        | 59          | TeleVideo/Terminals                       | 64                       | 32            |
| Hewlett-Packard Co./Mfg.              | 54         | 28          | Texas Instruments                         | 157-160                  | —             |
| Honeywell Test Instrument Div.        | 4, 116-117 | 4, 57       | TRW Inc./Customer Service Div.            | 143                      | 72            |
| IBC/Integrated Business Computers     | 142        | 71          | Universal Data Systems Inc.               | Cov. 4                   | 82            |
| IBS                                   | 116        | 84          | Walker, Richer, & Quinn                   | 123                      | 60            |
| Illbruck/USA                          | 32         | 20          | Western Digital                           | 108                      | 53            |
| Imagen Corp.                          | 98         | 48          |                                           |                          |               |
| Imperial Technology Inc.              | 97         | 47          |                                           |                          |               |
| Innovative Data Technology (IDT)      | 175        | 213         |                                           |                          |               |
| Instanet Visuals                      | 176        | 223         |                                           |                          |               |
| Intelligent Interfaces                | 176        | 222         |                                           |                          |               |
|                                       |            |             | See P. 174-176 for Mini-Micro Marketplace |                          |               |

This index is provided as an additional service. The publisher does not assume any liability for errors or omissions.



CAD

CAM

CAE

+

CIM

C<sup>4</sup>

# N · C · G · A '87 CAD/CAM

## Shows How to Make the Equation Work for You...

Focused on the Impact of Personal Computers and Workstations on the Engineering, Manufacturing and AEC Environments

.....  
A four-day conference and three-day exposition dedicated to the theory and specifics that will make computer-aided design, manufacturing and engineering, as well as computer-integrated manufacturing work in your organization.

### The Conference

Conference Director Carl Machover has planned more than 30 dynamic conference sessions on all phases of computer-aided engineering, manufacturing and AEC: PC applications, mechanical CAE and CAD, CD ROM, human factors and management issues, expert systems, and much more.

### The Exposition

More than 40 major vendors of hardware, software and services will display their PCs, workstations, peripherals, publications and more, specifically designed for CAD, CAM, CAE, CIM and AEC.

### For More Information

Simply return the response card and the information will be on its way. Or call the information hotline, 1-800-225-NCGA or 703-698-9600.

C<sup>4</sup> is the comprehensive implementation of computer-aided technology for greater productivity. Come to NCGA CAD/CAM '87 and see what that adds up to for you.

.....  
**Bayside Exposition Center, Boston, Mass.  
August 17-20, 1987**  
.....

Send coupon to:



**National Computer Graphics Association**  
Department TK, Suite 200  
2722 Merrilee Drive  
Fairfax, VA 22031

.....  
Send me complete information about NCGA CAD/CAM '87.  
.....

\_\_\_\_\_  
Name

\_\_\_\_\_  
Title

\_\_\_\_\_  
Company

\_\_\_\_\_  
Address

\_\_\_\_\_  
City State ZIP

# MINI-MICRO MARKETPLACE

**ATTENTION: BUYERS AND SELLERS OF PRODUCTS AND SERVICES IN THE COMPUTER SYSTEMS INTEGRATION MARKETPLACE:**

**READERS:** For additional information on the companies in this section, please circle reader service numbers on the Reader Inquiry card

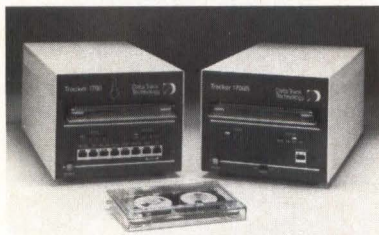

### TRACKER 1700 STAND ALONE 15 TO 20 MBYTE POWER FAIL PROTECTED RS-232-C CARTRIDGE TAPE SYSTEM

- Uses DC-300 Data Cartridges
  - Automatic Power Fail Restart with NO DATA LOSS
  - Auto-answer for Remote Sight Polling
  - 24K Battery Backed CMOS Buffered Stop-Start system
  - Dual RS-232-C ports with Independent Baud rate select
  - Ideal replacement for Columbia, Tektronics and Tandburg tape drives.
  - Quantity priced under 2000.00
- Ideal applications: Data Logging, Telephone Call Logging, File Transfer, Data Archiving, Process Control System Monitoring. For All of Your RS-232-C Data Storage Needs Contact



**Data Track USA**  
9451 Sohaph Lane  
Columbia, MD 21045  
301-992-9143  
Telex: 6971182 COLRESH

**CIRCLE NO. 201 ON INQUIRY CARD**

## THE Expert System for Good Writing

**RIGHTWRITER® VERSION 2.1**  
THE Intelligent Grammar & Style Checker

- Automatically finds errors in grammar, style, usage and punctuation.
- Works with WordStar®, MultiMate®, and twenty other leading word processors.
- A knowledge base of over 3000 rules.
- Calculates the overall reading grade level.
- Comprehensive user manual included.

**PRICE**  
**\$9500**

**RIGHTSOFT**  
INCORPORATED  
2033 Wood Street • Suite 218  
Sarasota, Florida 33577 • Phone (813) 952-9211

**CIRCLE NO. 203 ON INQUIRY CARD**

### AVOID COMPUTER DOWNTIME!

- 11-25 MINUTES  
BLACKOUT  
POWER

- FRONT PANEL  
TEST SWITCH



**FREE CATALOG**

- **SineZUPS** – NATURAL SINE WAVE UPS
- CONTINUOUS ON-LINE OPERATION
- ELIMINATE:
  - BLACKOUT
  - SPIKE/SURGE
  - BROWNOUT DAMAGE
  - EMI/RFI INTERFERENCE
- EXCLUSIVE LITE UPS ILLUMINATE WORK AREA WHEN LIGHTS GO OUT
- SINE-UPS, BATTERIES & LITE UPS
  - SU-250 250 WATT \$1095.00
  - SU-500 500 WATT \$1495.00

**ESP Electronic Specialists, Inc.**  
171 SO. MAIN, NATICK, MA 01760  
617-655-1532 TOLL FREE 800-225-4876  
VISA, MASTERCARD, AMERICAN EXPRESS  
**CIRCLE NO. 204 ON INQUIRY CARD**

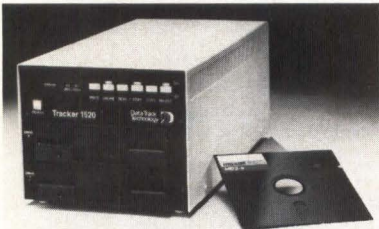

### IBM-PC/XT/AT COMPATIBLE POWER FAIL PROTECTED RS-232-C FLOPPY DATA COLLECTION AND TRANSFER SYSTEM WITH UP TO 2.4 MBYTE OF STORAGE

- Writes/Reads IBM PC/XT/AT compatible Disc
  - Power Fail Protected with NO Data Loss
  - Remote polling via auto answer modem
  - Front panel manual or remote operation
  - Single or Dual Disc system
  - Up to 223 Files/Disc
- Applications include: Data Logging, Program Loading, Telephone Call Logging, Store & Forward, and Message Handling. For All of Your RS-232-C Data Storage Needs Call



**Data Track USA**  
9451 Sohaph Lane  
Columbia, MD 21045  
301-992-9143  
Telex: 6971182 COLRESH

**CIRCLE NO. 202 ON INQUIRY CARD**

## EPROM PROGRAMMER \$349

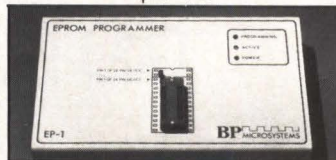

**The EP-1 is a great value, here's why:**

- IBM PC Software included or RS-232 to any computer
- ASCII Command driven operation. All intelligence in unit
- Reads, Programs, Copies over 150 types from 2716 to 27512
- Optional Intel microcontroller programming head
- Menu-driven Chip Selection: No Personality Modules
- Fast, Slow, Quick-Pulse Programming Algorithms
- Intel (8080 & 8086), Motorola, Tekhex, Straight Hex Files
- Splits Files by Base Address and Odd/Even (16 bit systems)
- Gold Textool ZIF IC socket
- Full One-Year Warranty
- Generate & Set Checksums
- 5.12, 5.21, 25V Programming
- Over-Current Protection
- U.V. Erasers from \$34.95
- 8 Baud Rates 300 to 38,400
- Same Day Shipment

**BP MICROSYSTEMS**  
10681 Haddington, #190 / Houston, TX 77043  
(713) 461-9430 (800) 225-2102

**CIRCLE NO. 205 ON INQUIRY CARD**

## Get the whole story on graphics terminal emulation.



To find out more about software that lets your PC emulate **TEKTRONIX™ 4105/6/7/9** and **DEC VT100™** terminals, call or write:

**GRAFFPOINT**  
4340 Stevens Creeks Blvd., Suite 280,  
San Jose, CA 95129 (408) 249-7951

**CIRCLE NO. 206 ON INQUIRY CARD**

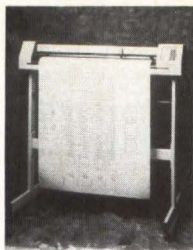

## PLOTS FASTER

Ioline's new LP4000 plotter is twice as fast with twice the resolution of our popular LP3700. Delivering the best possible performance at the lowest possible price - \$5,495.

- 20 ips axial. 28 ips diagonal.
- .001" resolution.
- Plots on any media through 37.5" x 81".
- 300 CAD/CAE applications.
- Optional multi-pen changer (up to 20), and HyperBUFFER (queues multiple plot files, and sorts vector and pen moves).



19417 36th Avenue West  
Lynnwood, WA 98036  
206-775-7861  
Telex: 4949856 IC UI

CIRCLE NO. 207 ON INQUIRY CARD

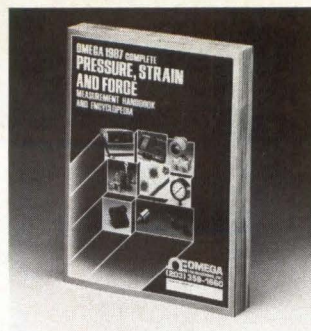

**Pressure, Strain and Force:** 320 pages, with a new section devoted to pressure switches. New for 1987 are force measurement products, along with a wide selection of pressure transducers, strain gage sensors and load cell systems.

Call or write TODAY for more information!

Contact:  
**OMEGA ENGINEERING, INC.**  
AN OMEGA Group Company  
One Omega Drive  
P. O. Box 4047  
Stamford, CT 06907  
Telephone: (203) 359-7613  
Telex: 996404

CIRCLE NO. 208 ON INQUIRY CARD

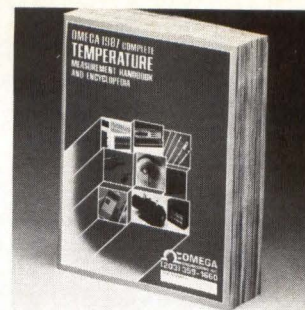

**Temperature:** 820 pages cover all aspects of temperature measurement and control. Shows hundreds of probes, accessories, wire, handheld and panel readouts, controllers, recorders and computer interface equipment. Many new products have been added this year, including humidity measurement systems, and data acquisition devices.

Call or write TODAY for more information!

Contact:  
**OMEGA ENGINEERING, INC.**  
AN OMEGA Group Company  
One Omega Drive  
P. O. Box 4047  
Stamford, CT 06907  
Telephone: (203) 359-7613  
Telex: 996404

CIRCLE NO. 209 ON INQUIRY CARD

## TERMINAL EMULATIONS

### NEW RELEASE! SOFTERM PC 2.0

- \* OVER 30 EXACT EMULATIONS
- \* KEYBOARD MACROS \* HOTKEY
- \* VIRTUAL DISK CAPABLE \* SCRIPT FILES
- \* KEYBOARD TRANSLATE \* MULTITASKING
- \* FILE TRANSFER WITH 7 PROTOCOLS  
(i.e. KERMIT-SERVER, HAYES, XMODEM, ETC.)
- \* CONCURRENT AND BACKGROUND COMMUNICATIONS

## SEIFTRONICS

THE LEADER IN EXACT EMULATIONS  
800/225-8590

303/593-9540

TELEX 450236

CIRCLE NO. 212 ON INQUIRY CARD

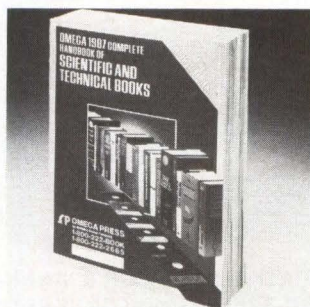

### OMEGA'S BOOK OF BOOKS

OMEGA'S Encyclopedia of Scientific and Technological Books is a one-stop ordering source for books from the major science and technology publishers of the world. This catalog gives information on over 12,000 books from 14 publishers covering 16 subject categories including all engineering disciplines, the sciences, math, engineering computer software, and computer science. For easy reference, books are "recommended", and noted as "new". Others are grouped into mini-libraries for easy ordering. All books can be ordered by calling an 800 number or by using the book's easy-to-use order form. Most major credit cards are honored.

Circle reader service number or write today to:

**OMEGA ENGINEERING**  
One Omega Drive, P. O. Box 4047  
Stamford, Connecticut 06907

CIRCLE NO. 210 ON INQUIRY CARD

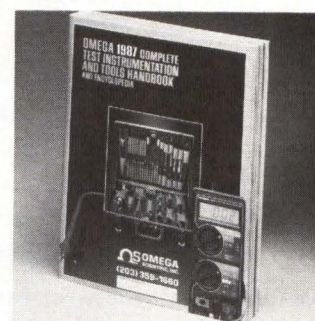

**Test Instrumentation and Tools:** This new edition contains everything for the well-equipped instrument technician, engineer and scientist. Complete tool kits, oscilloscopes, multimeters, computer cabling, and electronic assembly tools are only some of the new products highlighted within this 136 page full color handbook.

Call or write TODAY for more information!

Contact:  
**OMEGA ENGINEERING, INC.**  
AN OMEGA Group Company  
One Omega Drive  
P. O. Box 4047  
Stamford, CT 06907  
Telephone: (203) 359-7613  
Telex: 996404

CIRCLE NO. 211 ON INQUIRY CARD



## TAPENET™ Micro-to-Mainframe CONNECTIONS.

In today's information age, sharing data between your mainframe and PC is an essential link. Innovative Data Technology's 1/2-inch, 9-track tape subsystems feature the new "LEO" intelligent tape controller for the IBM-PC/XT/AT and compatibles including the new 386 PC's. These allow users to write and read 7 or 9 track, industry standard tapes in densities of 200/556/800/1600/6250 bpi with either ASCII or EBCDIC codes compatible with most mini's and mainframes. IDT offers user friendly DOS window software utilities with help screens that will enable you to move your mainframe data to your PC. IDT also has software support for XENIX and PICK operating systems.



Contact us today for your single vendor solution for your data interchange requirements.

5340 Eastgate Mall • San Diego, CA 92121  
(619) 587-0555 • TWX: (910) 335-1610  
Regional Office:  
Eastern: (609) 596-4538 • Western: (714) 968-8082

\*DOS/XENIX/PICK/IBM are registered trademarks of Microsoft/PICK/IBM respectively

CIRCLE NO. 213 ON INQUIRY CARD

## ENCLOSURE PRODUCTS

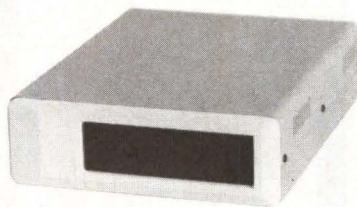

- Tape and Hard Disk Drive Enclosures for all Major Micros.
- Single Board Computer Packages
- Custom Design Available
- Class 'B' Certification Support
- Can Be Provided
- Call For Pricing and Catalog

## Microware Inc.

41711 Joy Road • Canton, MI 48187  
(313) 459-3557

CIRCLE NO. 214 ON INQUIRY CARD

## 9-Track Tape Subsystem for the IBM PC/XT/AT



Now you can exchange data files between your IBM PC and any mainframe or mini-computer using IBM compatible 1600 BPI 9-Track tape. Unit can also be used for disk backup. Transfer rate is up to 4 megabytes per minute on PCs and compatibles. Subsystems include 7" or 10 1/2" streaming tape drive, tape coupler card and DOS or XENIX compatible software. Prices start at \$2,995.

## QUALSTAR®

9621 Irondale Ave., Chatsworth, CA 91311  
Telephone: (818) 882-5822

CIRCLE NO. 215 ON INQUIRY CARD

## SOLUTIONS FOR DATA

### - NETWORK -

SWITCHING + MULTIPLEXING + CONCENTRATION

The Mc610 "Does It All"

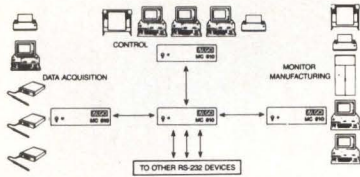

### NETWORK UP TO 500 RS-232 DEVICES

- Network All Manufacturing Divisions
- Save Money On Telephone Lines And Modems
- Error And Path Control
- Matrix Switch From Any Device To Any Other
- Broadcast From Any One Device To Any Or All Others
- Concentrate Data From Many Devices To A Single Port
- Multiple Composite Data Channels
- Menu Program For "Parameter Set-Up"
- Non-Volatile Parameter Memory

1-800-252-ALGO

CIRCLE NO. 216 ON INQUIRY CARD

## COLLECTION/CONTROL . AND

### Cartridge Tape Systems



Intelligent Stand Alone RS-232 or IEEE-488 Cartridge Tape System

Replacement for Tandberg, Columbia 300 B, C, & D and European MFG Tape Drives

- Stores 5.3 Mbytes or 20 Mbytes of Binary or ASC II Data
- Power Fail Standard-Power Fail "NO DATA LOSS" Optional
- Auto Answer Standard
- Intelligent Search & Retrieval
- IEEE-488 and/or RS-232-C with data rates up to 2,500 characters/sec
- Large input buffer allows unit to accept data non-stop

APPLICATIONS: Data Logging, Control System, Archiving, Program Loading & Storage, Back-up, and Telephone Switch Monitoring, Auto-pollled Remote Data Storage.

1200  
5.3 Mbyte

1600  
20 Mbyte

WE SERVICE COLUMBIA TAPE DRIVES  
300B - 300C - 300D  
Return Authorization Number Required

1-800-252-ALGO

CIRCLE NO. 217 ON INQUIRY CARD

## ADD RS-232 DATA STORAGE

### FLOPPY DISK SYSTEMS MS/PC-DOS Compatible



### CAPACITIES

- 360K, 720K 1.2 MEG 2.4 MEG
- Stand Alone Dual Port RS-232
- Manual and Remote Operation
- Power Fail with "No Data Loss"
- Auto Answer Standard
- Disk Full Buzzer
- 50/60 Hz Standard

### OPTIONS:

Battery Operated  
DC Operations; +12VDC to +50VDC  
IEEE-488 INTERFACE  
"Custom Software Available"

Priced from \$995.00 QTY 1



1-800-252-ALGO  
TELEX 333405 ALGO COL (301) 730-7442  
9198-C RED BRANCH ROAD, COLUMBIA, MD 21045

CIRCLE NO. 218 ON INQUIRY CARD

# BLAST

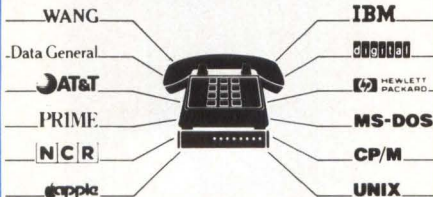

### PC to MINI to MAINFRAME COMMUNICATIONS SOFTWARE

The low cost solution for linking hundreds of PCs with central systems!

- An Asynchronous Connectivity Tool • No Boards - Uses standard RS-232 ports • Provides distributed data management • Sends binary or text data or commands • Sends spreadsheets, programs, etc • 100% error-free data transfer • Links different operating systems • Uses phone lines, LANs packet nets • Connects multiple sites, unattended • Uses any low-cost modems, any speed

• \$250 / Micros • \$495-895 / Minis • \$2995 up / Mainframes

### COMMUNICATIONS RESEARCH GROUP

5615 Corporate Blvd. Baton Rouge, LA 70808 (504) 923-0888

(800)-24-BLAST

CIRCLE NO. 219 ON INQUIRY CARD

### 9-TRACK TAPE • OCR SCANNING WORD PROCESSING CONVERSIONS

CONNECT your systems! We manufacture conversion systems for your PC/XT/AT. Our "DISKETTE CONNECTION" can read and write almost any WP or computer diskette. Our "SCANNING CONNECTION" captures text and images for your desktop publishing system. Our "TAPE CONNECTION" can read and write 800/1600/6250 GCR tapes. System prices start at \$1195.

Flagstaff Engineering • 1120 Kaibab  
Flagstaff, AZ 86001 • 602-779-3341  
CIRCLE NO. 220 ON INQUIRY CARD

### IBM COMPATIBLE RS232 EASI-DISK 3 1/2 5/4" FLOPPY DATA STORAGE & TRANSFER SYSTEM



Information Transfer to/from Non IBM Compatible Systems to/from IBM systems: (Over RS232 Interface).

- Reads & Writes IBM DOS 3 1/2 5/4" Disks
- RS-232C I/O
- Rugged Portable Package/ Battery Option
- ASCII or Full Binary Operation
- Baud Rates 110 to 19.2 K Baud
- Automatic Data Verification
- Price \$995 in Singles - OEM Qties. Less.

28 other systems with storage from 100K to 35 megabytes.



ANALOG & DIGITAL PERIPHERALS, INC.  
815 Diana Drive Troy, Ohio 45373  
513/339-2241 TWX 810/450-2685

CIRCLE NO. 221 ON INQUIRY CARD

### PLOTTER/PRINTER BUFFERS IEEE-488 or RS-232 Interfaces



MicroPlot 80A-HPIB Buffer MicroPlot 55-Serial Buffer

**YOU DON'T HAVE TO WASTE TIME WAITING ON SLOW PLOTS OR PRINTOUTS!** Simply connect a MicroPlot buffer between your computer and plotter or printer. You save time - hours of time if you're working with complex plots.

- Multiple copy and plot queuing
- Bidirectional Buffering
- Built-in Self Test
- One Year Warranty

256K - \$995 512K - \$1195  
1 Mbyte - \$1495 2 Mbyte - \$1995

INTELLIGENT INTERFACES INC.  
P.O. Box 1486/Stone Mountain, GA 30086-1486  
1-800-842-0888 In Georgia (404) 381-9891

CIRCLE NO. 222 ON INQUIRY CARD

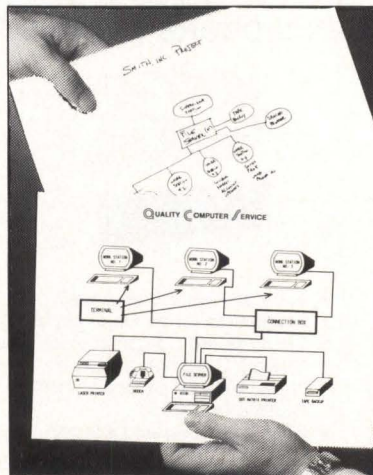

# INSTA-NET VISUALS

Your Network Sales Presentation Should Be As Professional As You Are... And It Can With

### THE GREAT GRAPHIC EQUALIZER!

You can help clients clearly see and understand your network design and function by using this easy graphics system...just like the biggest companies do...and you'll find that the best presentations will land the biggest contracts!

For only  
**\$16.79**

you get enough graphically compatible apply-on stickers and grid boards to design many multiple systems.

plus \$3.00 shipping and handling  
Texas Residents add .0625% Sales Tax

MC and VISA orders call toll-free  
California: 1-800-331-5236 ext.#443  
National: 1-800-992-4045 ext.#443

or send check or money order to:  
Insta-Net  
P.O. Box 161486  
Fort Worth, Texas 76161

CIRCLE NO. 223 ON INQUIRY CARD

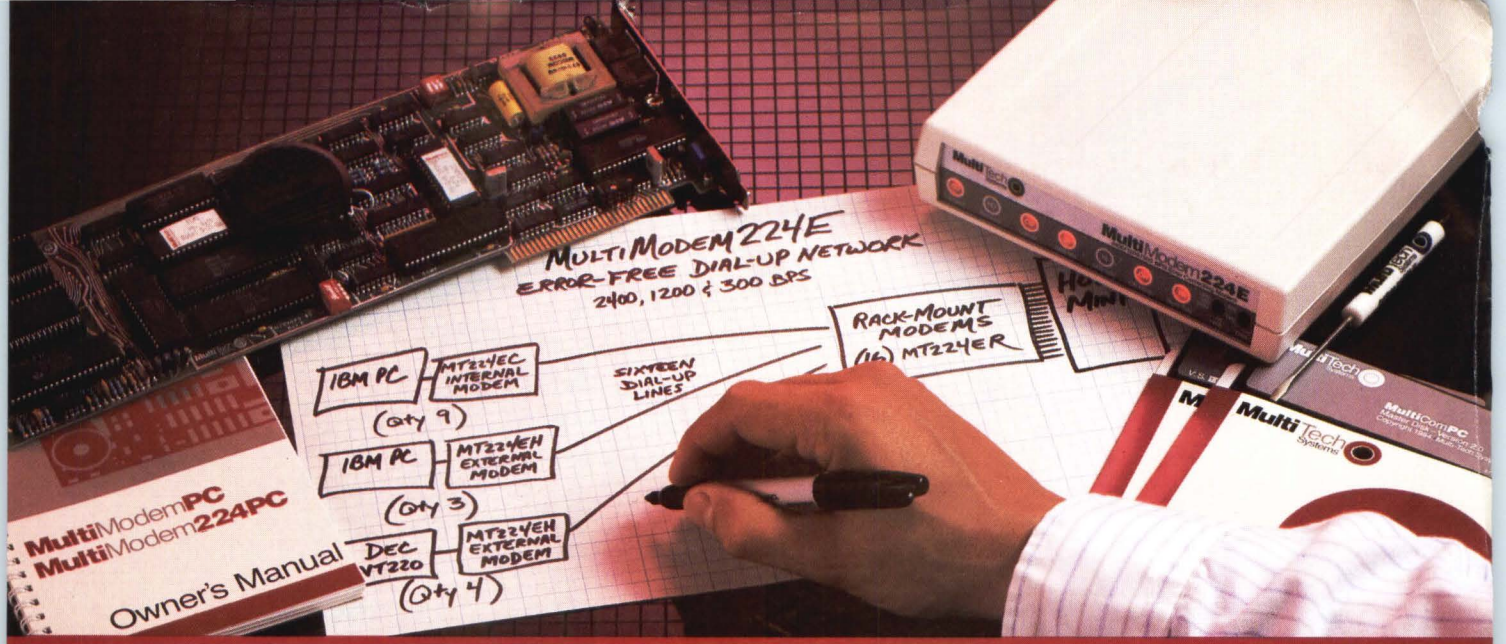

## Error-Correcting 2400 bps Modems from Multi-Tech Systems: When it has to be as good as it is fast

- Dial-up 2400 bps modems have arrived. More datacomm users are upgrading from 1200 to 2400 than ever before. But there can be a flip side to increased speed: more transmission errors.
- That's why our MultiModem224E™ offers MNP™ error correction. Available in our 2400 bps desktop, internal and rack-mounted modems, MNP gives you 100% error-free transmissions, no matter how bad the phone line. MNP does it without the speed degradation of less efficient, software-based protocols.
- Another important point: MNP Class 3 has emerged as an industry standard. It's now in the public domain, and has been implemented in virtually all 2400 bps modems that offer error-correction.

● So, why buy error-correcting modems from Multi-Tech? There are many good reasons, including:

1. Multi-Tech modems are 100% Hayes-compatible (more so than Hayes' own 2400 bps modems\*), and our MultiModem224E with error-correction costs less than a Hayes Smartmodem 2400™ without this feature.
2. Bonus features, like speed conversion, both synch and asynch operation, battery-backed option settings and phone number memory.
3. Versatility: the auto-dial/auto-answer MultiModem224E runs at 2400, 1200 or 300 bps, with or without error-correction, automatically!
4. Our two year warranty means something. Since Multi-Tech modems are designed and manufactured at our Minnesota headquarters (as they have been for the last sixteen years), you can be sure we'll be here when you need us.

● Please call us toll-free at **1-800-328-9717**, for additional information... get a modem that's as good as it is fast!

\*InfoWorld-8/5/85-reprints available

Trademarks: MultiModem and the Multi-Tech Systems logo:  
Multi-Tech Systems Inc. • MNP: Microcom Inc.  
Smartmodem: Hayes Microcomputer Products, Inc.

# MultiTech Systems

*The right answer every time.*

Multi-Tech Systems, Inc. • 82 Second Avenue S.E. • New Brighton, Minnesota 55112 U.S.A.  
1-800-328-9717 • 1-612-631-3550 • TWX 910-563-3610 (Domestic) • Telex 4998372 MLTTC (International)  
CIRCLE NO. 81 ON INQUIRY CARD



# A special kind of craftsmanship

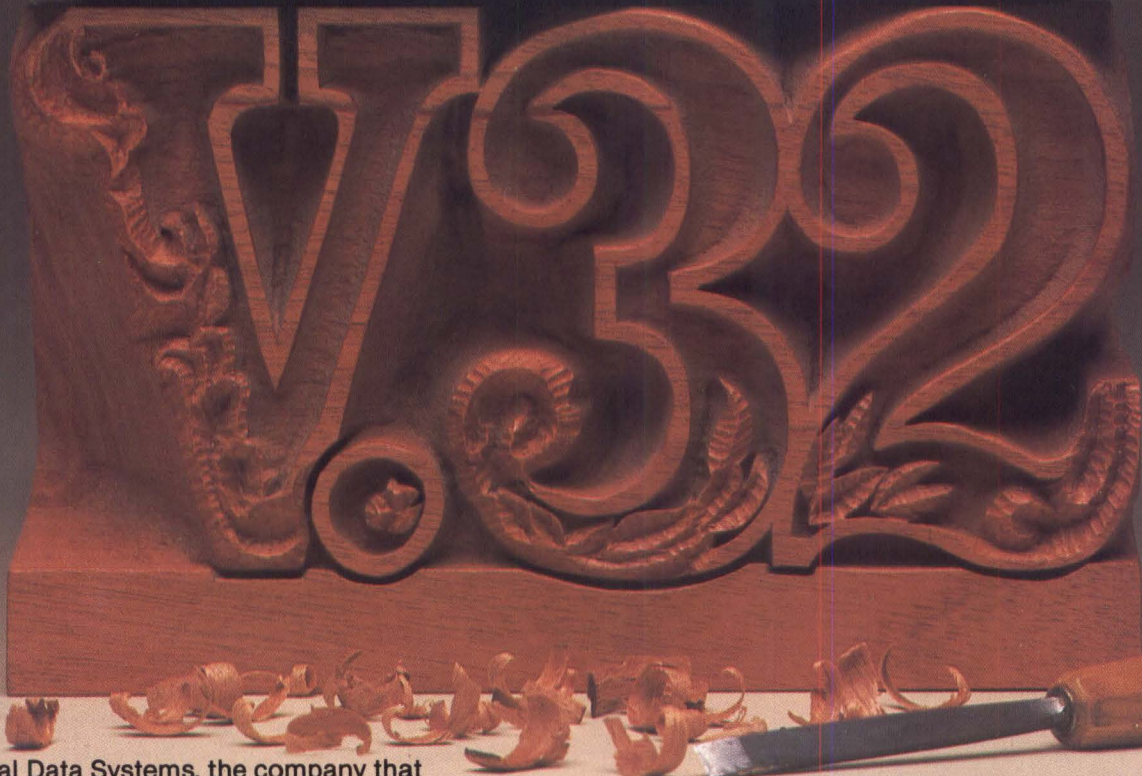
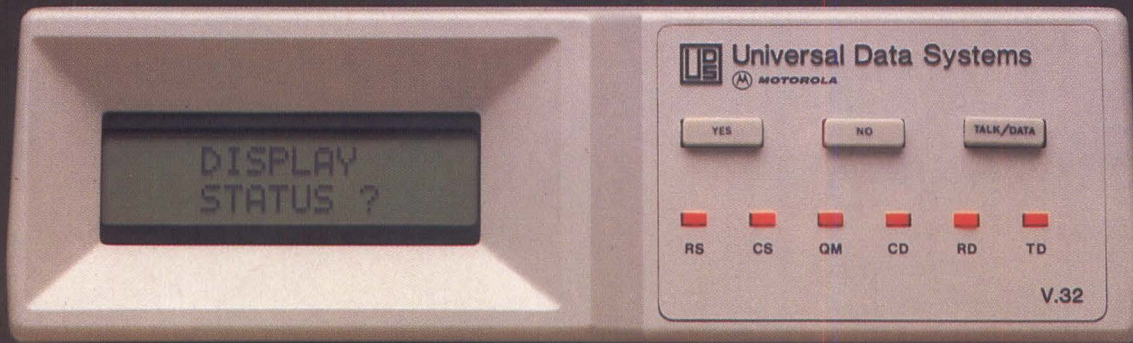

Universal Data Systems, the company that developed the first 9600 bps dial-up modem, has now applied its special brand of craftsmanship to the CCITT V.32 specification.

The result is a *full-duplex* 9600 bps device for the switched telephone network. When substandard line conditions are encountered, the device offers automatic fallback to 4800 bps, while maintaining the full-duplex communications capability.

As you expect from UDS, the device fully utilizes the latest in CMOS technology for low-noise performance and very low (less than 20W) power consumption. A new LCD control panel displays and configures modem set-up selections and displays outputs from the unit's comprehensive self-test regime. Auto-dial capability is also included.

If your system must accommodate periodic bursts of high-throughput, full-duplex communication, UDS craftsmanship and the V.32 standard provide a reliable, cost-effective solution. For complete technical details and quantity prices, contact Universal Data Systems, 5000 Bradford Drive, Huntsville, AL 35805. Telephone 205/721-8000; Telex 752602 UDS HTV.

**\$2495<sup>00</sup>**  
Quantity One

CIRCLE NO. 82 ON INQUIRY CARD



Universal Data Systems



**MOTOROLA INC.**  
Information Systems Group

UDS modems are offered nationally by leading distributors. Call the nearest UDS office for distributor listings in your area.  
DISTRICT OFFICES: Apple Valley, MN, 612/432-2344 • Atlanta, GA, 404/998-2715 • Aurora, CO, 303/368-9000 • Blue Bell, PA, 215/643-2336 • Boston, MA, 617/875-8868 • Columbus, OH, 614/895-3025 • East Brunswick, NJ, 201/238-1515 • Glenview, IL, 312/998-8180 • Houston, TX, 713/988-5506 • Huntsville, AL, 205/721-8000 • Issaquah, WA, 206/392-9600 • Livonia, MI, 313/522-4750 • Mesa, AZ, 602/820-6611 • Milwaukee, WI, 414/273-8743 • Mission Viejo, CA, 714/770-4555 • Mountain View, CA, 415/969-3323 • Richardson, TX, 214/680-0002 • St. Louis, MO, 314/434-4919 • St. Peters, MO, 314/434-4919 • Silver Spring, MD, 301/942-8558 • Tampa, FL, 813/684-0615 • Uniondale, NY, 516/222-0918 • Van Nuys, CA, 818/891-3282 • Willowdale, Ont, Can, 416/495-0008 • Winston-Salem, NC, 919/760-4184