

# ON Semiconductor

## Is Now

# onsemi™

To learn more about onsemi™, please visit our website at  
[www.onsemi.com](http://www.onsemi.com)

---

**onsemi** and **onsemi** and other names, marks, and brands are registered and/or common law trademarks of Semiconductor Components Industries, LLC dba "**onsemi**" or its affiliates and/or subsidiaries in the United States and/or other countries. **onsemi** owns the rights to a number of patents, trademarks, copyrights, trade secrets, and other intellectual property. A listing of **onsemi** product/patent coverage may be accessed at [www.onsemi.com/site/pdf/Patent-Marking.pdf](http://www.onsemi.com/site/pdf/Patent-Marking.pdf). **onsemi** reserves the right to make changes at any time to any products or information herein, without notice. The information herein is provided "as-is" and **onsemi** makes no warranty, representation or guarantee regarding the accuracy of the information, product features, availability, functionality, or suitability of its products for any particular purpose, nor does **onsemi** assume any liability arising out of the application or use of any product or circuit, and specifically disclaims any and all liability, including without limitation special, consequential or incidental damages. Buyer is responsible for its products and applications using **onsemi** products, including compliance with all laws, regulations and safety requirements or standards, regardless of any support or applications information provided by **onsemi**. "Typical" parameters which may be provided in **onsemi** data sheets and/or specifications can and do vary in different applications and actual performance may vary over time. All operating parameters, including "Typicals" must be validated for each customer application by customer's technical experts. **onsemi** does not convey any license under any of its intellectual property rights nor the rights of others. **onsemi** products are not designed, intended, or authorized for use as a critical component in life support systems or any FDA Class 3 medical devices or medical devices with a same or similar classification in a foreign jurisdiction or any devices intended for implantation in the human body. Should Buyer purchase or use **onsemi** products for any such unintended or unauthorized application, Buyer shall indemnify and hold **onsemi** and its officers, employees, subsidiaries, affiliates, and distributors harmless against all claims, costs, damages, and expenses, and reasonable attorney fees arising out of, directly or indirectly, any claim of personal injury or death associated with such unintended or unauthorized use, even if such claim alleges that **onsemi** was negligent regarding the design or manufacture of the part. **onsemi** is an Equal Opportunity/Affirmative Action Employer. This literature is subject to all applicable copyright laws and is not for resale in any manner. Other names and brands may be claimed as the property of others.

## SPM2 (ASPM 34) Package Assembly Guidance

For 32L (FSAM-) and 34L (FNA-, NFVA-)



ON Semiconductor®

[www.onsemi.com](http://www.onsemi.com)

### APPLICATION NOTE

#### INTRODUCTION

ON Semiconductor SPM 2 (ASPM 34) series is a compact semiconductor power module in Dual Inline with high-functionality and high efficiency. Target applications are motor drives for industrial and automotive use such as air conditioners, servo motors, electric compressors and general-purpose inverters. Proper mounting is required to achieve good thermal performance and low mechanical stress during lifetime of the device. Figure 1 shows the assembly process flow for SPM 2 32L and SPM 2(ASPM 34) 34L packages. Assemblies commonly are done using method 1 or method 2 by customer's determination.

This application note is intended to provide recommendations for proper handling, assembly of the package and potential rework in conjunction with industry standards. Following sections outline appropriate TIM (Thermal Interface Material) application and heat sink mounting as well as soldering procedures to ensure a reliable PCB (Printed Circuit Board) connection. Recommendations in this note are based on simulation and experimental results from laboratory and field tests.

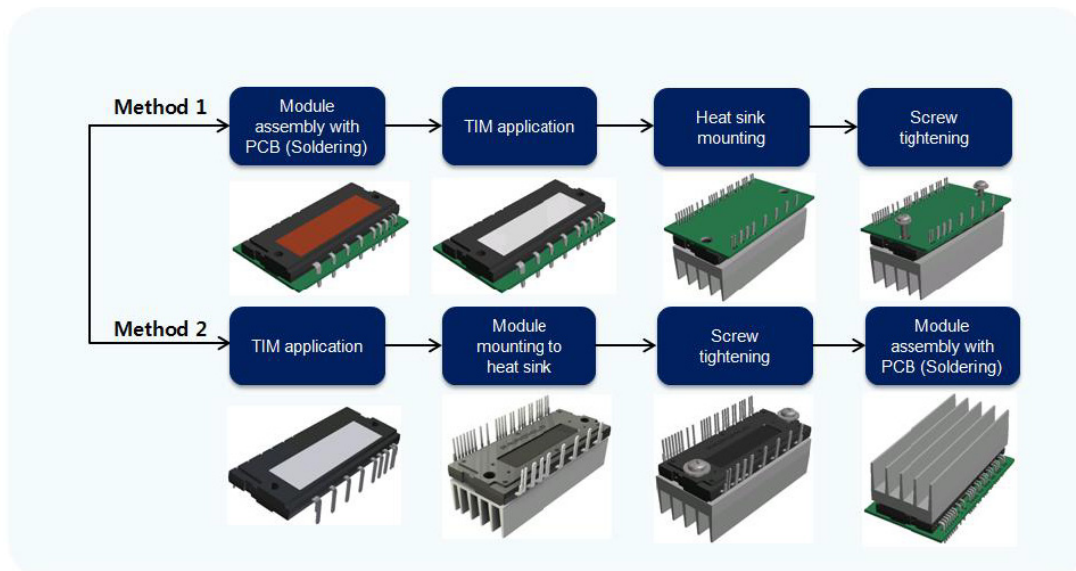
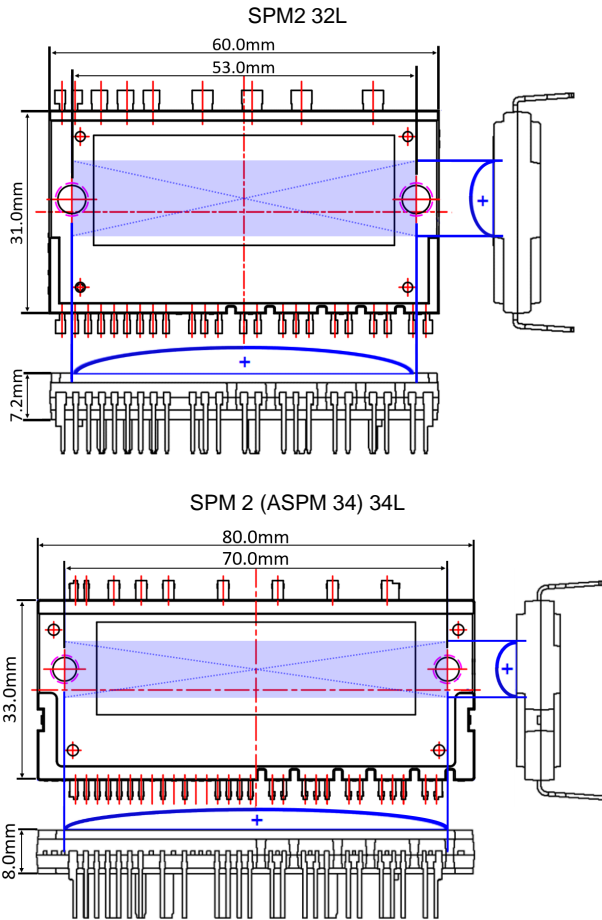

Figure 1. SPM 2 (ASPM 34) Module Assembly Process Flow

**GENERAL PACKAGE INFORMATION**

**Package Surface Specification**

The measurement area for the flatness of the package surface is specified by the package center and the four outside corners, as shown in Figure 2. Flatness for the SPM 2 (ASPM 34) is specified in Table 1. The surface shows a convex bow shape but when the module is screwed down with torque, the thermal compound spreads out and fills the air gaps between the two contact partners, finally ensuring full contact.



**Figure 2. Device Flatness Measurement Zone**

**Table 1. SPECIFICATION OF THE SPM 2 (ASPM 34) PACKAGE SURFACE**

Package	Min	Typ	Max
SPM2 32 L	0		+120 $\mu\text{m}$
SPM 2 (ASPM 34) 34 L	0		+200 $\mu\text{m}$

**Heat Sink Surface Specification**

An heat sink is a passive heat exchanger that is designed to absorb and disperse heat away from the power devices. The thermal performance of a module is influenced by the quality of the surface contact to the heat sink. To optimize the thermal dissipation it is required to maintain a high

quality of the heat sink surface. Surface flatness and roughness are the key factors to be considered when manufacturing the heat sink. In order to obtain the maximum thermal conductivity of heat sink and module, the specification given in Table 2 and Figure 3 needs to be followed. The surface of the heat sink must be clean and free of particles. Besides the surface quality, the heat sink design is also one of the key factors that improve the heat dissipation capability of a device.

**Table 2. HEAT SINK SURFACE REQUIREMENTS**

Parameter	Requirement
(a) Flatness of heat sink	-50 ~ 100 ( $\mu\text{m}$ )
(b) Geometrical surface roughness (Rz)	$\leq 10$ ( $\mu\text{m}$ ) to DIN EN ISO 4287

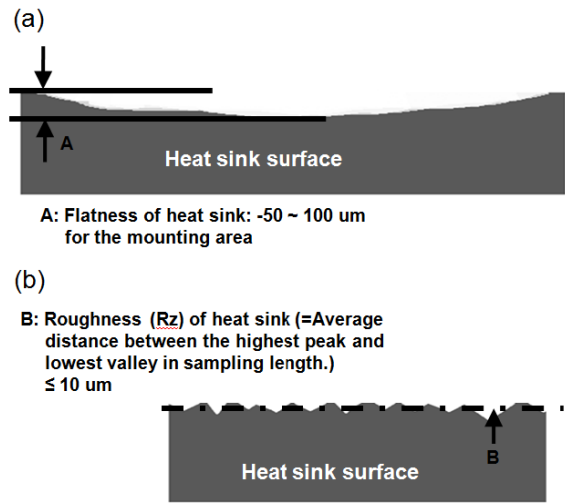

**Figure 3. Microscopic View of Surfaces. A is Flatness and B is Roughness (Rz).**

**Specification of External Terminals**

Table 3 shows technical features of the external terminals. The capability of the leads in terms of pulling and bending are evaluated to check the devices to withstand stresses from actual handling and assembly of the devices in application. The heat resistance of the terminal is also evaluated according to JESD22-B106.

**Table 3. MECHANICAL CHARACTERISTICS OF EXTERNAL TERMINALS**

Parameter		Description
Material	Main material	Cu Alloy
	Plating material	Ag partial plating (min 3 $\mu\text{m}$ )
Pulling strength, Load 19.6 N acc. to EIAJ-ED-4701		Min. 10 s
Bending strength, Load 9.8 N 90° bend acc. to JESD22-B105-C		Min. 2 times
Heat resistance test acc. to JESD22-B106		260 $\pm 5$ $^{\circ}\text{C}$ , 10 $\pm 1$ s

**Clearance and Creepage Distance**

Since electrical isolation is directly related to the reliability of the product and its safety, it is considered as an important design factor of a power package. The spacing distance between components that are required to withstand a given working voltage and the environment (depending on the pollution degree, temperature and relative humidity) is specified in the terms of Clearance and Creepage in IEC 61800-5-1. Clearance is defined as the shortest distance through the air between two conductive parts. Creepage is defined as the shortest path between two conductive parts measured along the surface of an isolator.

The specification of the electric spacing between the leads is described in Table 4 and 5 as well as in Figure 4 and 5. After heat sink mounting, the minimum clearance and creepage distance between the leads and the heat sink are 3.8 mm and 6.06 mm respectively. In order to maintaining certain spacing addressed in the relevant standard after heat sink and PCB assembly, creepage and clearance need to be checked and additional measures to enlarge the creepage and clearance distances may need to be applied. Figure 6 shows

one of example how to achieve the enlarger creepage and clearance by modify the heat sink shape.

**Table 4. MINIMUM DISTANCE FOR ISOLATION FOR 32L**

Location	Clearance [mm]	Creepage Distance [mm]
A. Between Power Terminals	4.42	4.62
B. Between Control Terminals	2.70	4.90
C. Between Terminals & H/S	3.00	4.30

**Table 5. MINIMUM DISTANCE FOR ISOLATION FOR 34L**

Location	Clearance [mm]	Creepage Distance [mm]
D. Between Power Terminals	7.80	8.00
E. Between Control Terminals	3.05	6.85
F. Between Terminals & H/S	3.80	6.06

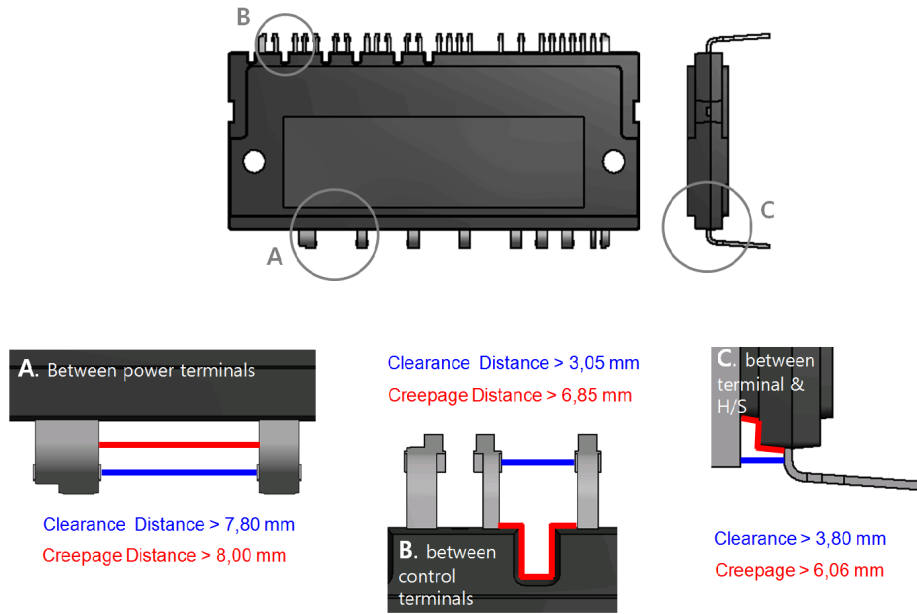

**Figure 4. Distance for Isolation from Pin To Pin and from Pins to Heat Sink (SPM 2 (ASPM 34) 34L)**

## AND90068/D

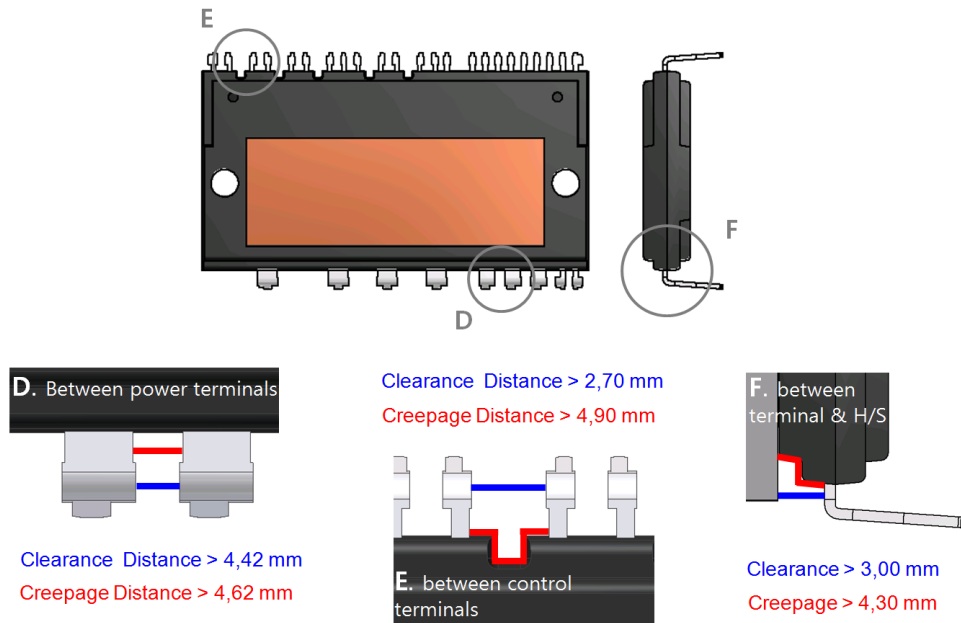

Figure 5. Distance for Isolation from Pin To Pin and from Pins to Heat Sink (SPM2 32L)

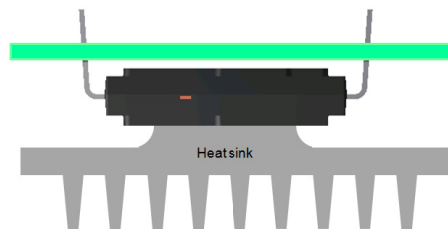

Figure 6. Creepage and Clearance Improvements by Heat Sink Modification

### ASSEMBLY SEQUENCES

The assembly process can be done in two ways. One method is mounting the module onto the heat sink first and then proceed with soldering. (Section ‘Soldering to the PCB’) On the contrary, soldering the module on the PCB can be done first, then mounting on the heat sink is done after. (Section ‘Module Mounting to the Heat Sink First’)

#### Soldering to the PCB, then Mounting to the Heat Sink

If module is assembled with the PCB first and heat sink mounting is conducted later, process flow described in Figure 7 and Figure 8 is recommendable. Firstly, the module is placed on the PCB until the lead stopper contacts with the PCB (a). Then, soldering to PCB is done (b). Minimum distance between PCB and heat sink is designed to be  $H_1$  and the distance between module and PCB is  $H_2$ , as described in Table 6.

Manual soldering and wave soldering are the general practices to assemble the module onto the PCB. At manual soldering, both bottom side and top side soldering is available. Wave soldering system consists typically of solder fluxing, preheating zone, solder wave and the cooling zone. As the board enters the conveyerized process, solder

flux is sprayed or foamed onto the modules. Then it moves to the preheating zones, normally done by convection, where the flux is activated. The assembly then moves to wave soldering. The assembly is slowly cooled down after [1]. More details about the soldering process and the conditions for SPM 2 (ASPM 34) packages are described in Section ‘Soldering Guidelines’.

- (a) Place the module on the PCB until the stopper touch the PCB surface.

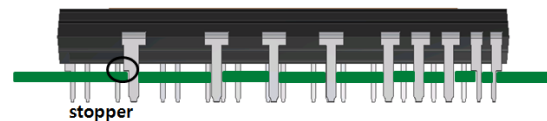

- (b) Soldering the pins to the PCB (wave or manual soldering).

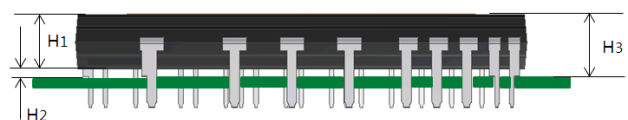

Figure 7. Process Flow of Soldering a SPM 2 (ASPM 34) Package (when PCB mounting first)

**Table 6. SPECIFICATION OF H<sub>1</sub> AND H<sub>2</sub>**

Package	H <sub>1</sub>	H <sub>2</sub>	H <sub>3</sub>
SPM2 32 L	7.20 mm	0.98 mm	8.18 mm
SPM 2 (ASPM 34) 34 L	8.00 mm	1.00 mm	9.00 mm

After PCB assembly is done, TIM (Thermal Interface Material) is applied on the surface of DBC or heat sink (c). Place module onto the heat sink and screws to the heat sink (d). Recommendable TIM application and screw tightening method are followed in Section ‘Thermal Interface Materials for Electronics Cooling’ and ‘Screw Tightening Guideline’ section.

- (c) Apply thermal interface material on the module or heat sink surface

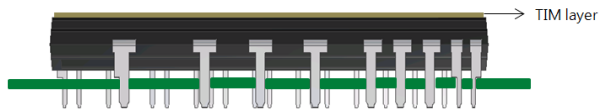

- (d) Place the module onto the heat sink and fasten the screws (Without spacers between PCB and heat sink.) Refer to Section 5.2 for more detail procedure

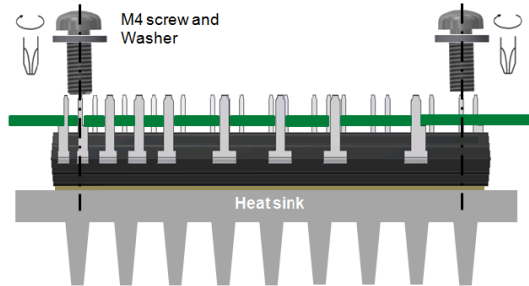

**Figure 8. Process Flow of Mounting a SPM 2 (ASPM 34) Package (when PCB mounting first)**

**Module Mounting to the Heat Sink First, then Soldering to the Board**

When the module is mounted onto the heat sink before PCB mounting, a process flow as illustrated in Figure 9 is recommendable. Firstly, apply TIM on the surface of DBC or heat sink and place the module on the heat sink (a). Tighten the screws down to heat sink (b). Then the module with the heat sink is placed onto the PCB (c). Finally, the

solder joint between pins and PCB is formed (selective soldering process, manual) (d).

- (a) Apply thermal interface material on the module or heat sink surface and place module onto the heat sink

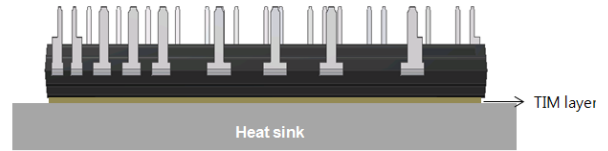

- (b) Tighten up the modules with the heat sink using M4 screw.

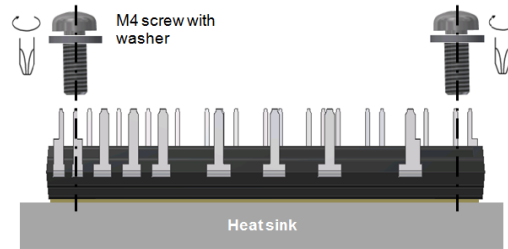

- (c) Place the PCB until the stopper touch the PCB surface.
- (d) Soldering the pins to the PCB

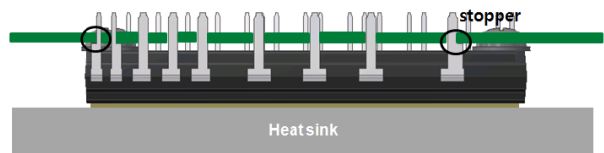
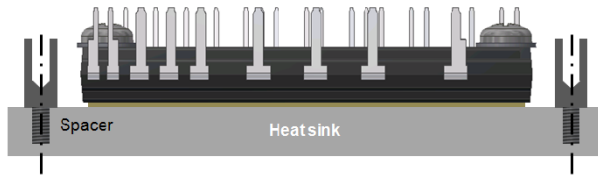

**Figure 9. Process Flow of Mounting a SPM 2 (ASPM 34) Package (when PCB mounting first)**

**System Considerations**

After module is assembled to the PCB and the heat sink as described above, the overall structural integrity needs to be considered in terms of mechanical stress to any of the system components. In case the PCB is large and heavy with other components assembled to it, there is some risk the PCB can bend, creating mechanical stress to the module and the PCB. In addition, when multiple modules are applied to the same PCB, height tolerance between modules can result in mechanical stresses to the board and modules. As an option, to reduce stress, spacers should be added on the heat sink, as illustrated in Figure 10, to prevent any possible movement of the PCB.

(c) Add spacers if necessary.



(d) Place the PCB until the stopper touch the PCB surface. Previous a soldering process, screwing the PCB with spacer if spacer is between heat sink and PCB.

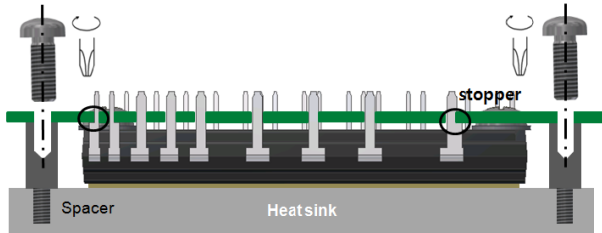

(e) Soldering the pins with PCB.

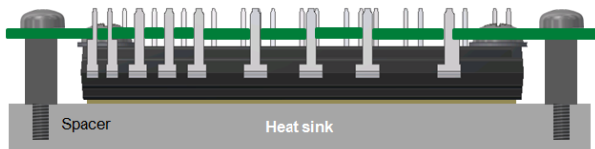
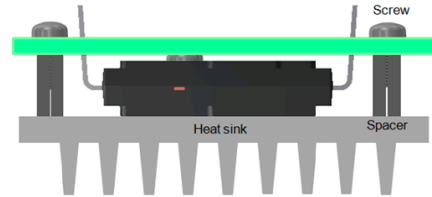

**Figure 10. Process Flow of a Soldering for SPM 2 (ASPM 34) Package (when spacers applied between PCB and heat sink)**

Figure 11 shows examples of spacer type. Option 1 shows individual spacers between heat sink and PCB. Option 2 shows a special shape of heat sink. And, option 3 is the spacer mounted between module and the PCB.

Mounting with the spacers

Option 1



Option 2

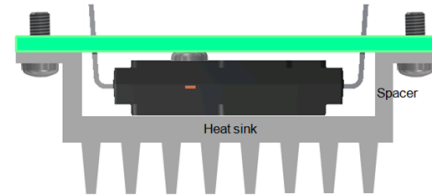

Option 3

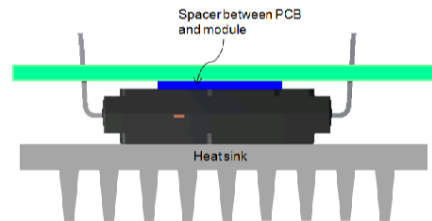

**Figure 11. Examples of the Spacer Type**

When the stopper of the pin touches the PCB the distance between PCB and heat sink is 7.2 mm for 32L and 8.0 mm for 34L. Therefore, the height of the spacer should be designed to be 7.2 (+0.1/-0.1) mm and 8.0 (+0.1/-0.1) mm.

Minimum height of spacer

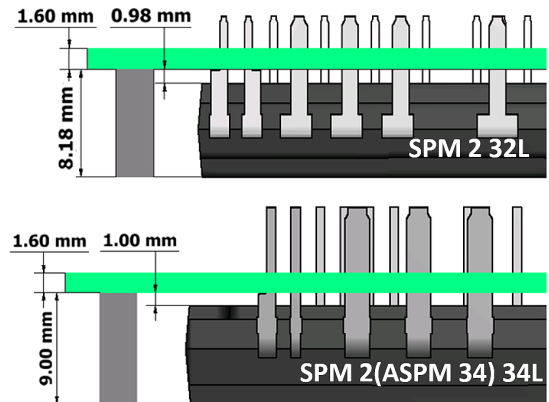

**Figure 12. Height of Spacer and Air Gap**

**THERMAL INTERFACE MATERIALS (TIMs) FOR ELECTRONICS COOLING**

Since the contact surfaces are not perfectly flat, multiple air gaps can form between two solid contact surfaces. Air is a poor heat conductor preventing the heat transfer and limiting the effective contact area. Thermal Interface Materials (TIMs) need to be applied between the heat sink and the DBC surface of the module to fill any air gaps and to achieve a low thermal resistance. Appendix 1 shows thermal resistance results comparing the assembly with and without TIM.

The following are the general considerations when choosing the material for the application. Besides its thermal conductivity also handling and rework performance may be important factors while selecting the proper TIM.

- High thermal conductivity
- Ease of distribution with low contact pressure
- Minimal thickness
- Degradation of characteristics over time
- Environmental
- Ease in handling during application or removal

Though thermal interface materials with improved performance are available nowadays, still the most commonly used in the industry is thermal grease. Thermal greases consists of silicone or hydrocarbon oils that contain various fillers which have good surface wetting

characteristics and flow easily to fill voids even at low mounting pressure. Standard thermal compounds have a thermal conductivity between 0.7–0.9 W/m–K while the thermal conductivity of high end compounds is in the range of 2.0–4.0 W/m–K or even above.

As an alternative PCM (Phase Change Material) provide improved reliability and high thermal performances as well as lower overall costs due to a simplified assembly process. It is recommended to contact your local ON Semiconductor representative for more information regarding PCM pre-applied modules.

**Manual TIM Application**

Thermal grease can be applied to the heat sink or the module back side using a rubber roller or spatula or by screen printing. A rubber roller, as shown in Figure 13, is an easy and fast method for applying thermal grease. Since the thermal grease has the lowest thermal conductivity in the thermal path, a layer as thin as possible is necessary to keep the overall thermal resistance low. Recommended thickness of printing layer is uniform dispense of a minimum 150 um. The thermal grease thickness can be checked using thickness gauges, such as wet film combs or wet film wheels. Figure 8 illustrates the application of thermal grease on the product. Since manual control of printing pressure and speed can be learned by experience, training is needed to achieve a technique for good quality printing in the application.



Thermal grease is applied on the heat sink evenly using the rubber roller. Firstly, thermal grease can be distributed in parallel direction with rolling repeatedly.



Thermal compound being applied to the device in parallel direction with several repetitions of rolling.

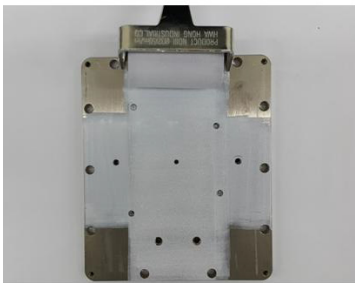

Then, thermal grease is applied in vertical direction with rolling repeatedly.

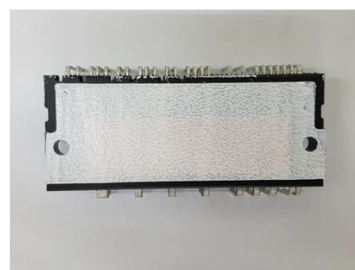

Since the thermal grease has the lowest thermal conductivity in the thermal path, a layer as thin as possible is necessary to keep the overall thermal resistance low.

Recommended thickness of printing layer for SPM 2 PKG is 150 - 200 um.



Thermal compound being applied to the device in vertical direction with several repetitions of rolling.

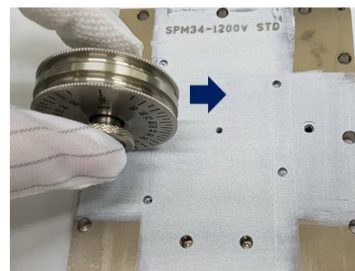

Check the thermal grease thickness with thickness gauges, such as wet film comb or wet film wheels.

**Figure 13. Example of Thermal Paste Application Using a Rubber Roller**

**TIM Application by Manual Screen Printer**

Stencil/screen printing can be utilized for the application of thermal paste. It allows a fast, clean and easy handling of spreadable TIMs. They can be applied to the DBC area, leaving out other parts of the module package using specifically designed stencils. An optimization of the screen mask pattern and thickness is required to achieve a good

quality of the print and finally an optimum contact. Figure 14 shows an example of thermal paste application process using a manual screen print.

Fully automated screen printing is recommended in mass production. It a good quality of printing layer with high accuracy and repeatability.

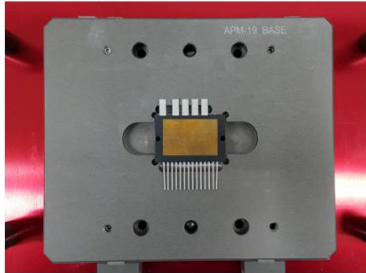

Place the module on the mounting jig. Ensure the DBC area is clean. (Sample is APM 19)



Place the squeegee or spatula behind the TIM and tilt down it to have 45° angle around. Apply a certain pressure and draw the squeegee downwards slowly.

Maintaining the constant printing pressure and speed make possible to achieve uniform pattern of printing layer.

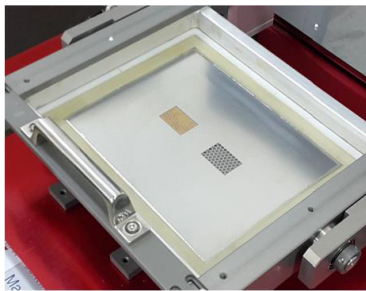

Aligning and positioning of the screen mask to the module DBC area

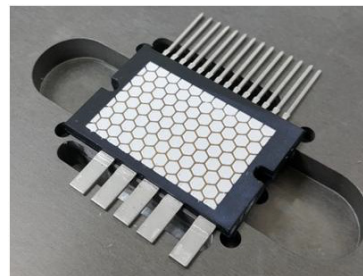

Lift the screen mask and do visual inspection after application

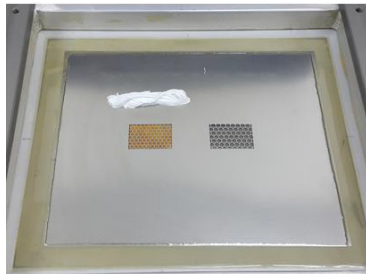

Dispense the thermal interface material on the screen mask

**Figure 14. Example (APM 19 Package) of Thermal Paste Application Using a Manual Screen Print**

**SCREW TIGHTENING GUIDELINE**

**Screw and Mounting Torque**

SPM2 package should be secured on the heat sink via two M4 screws. The location of the screw holes are illustrated in Figure 15. Table 7 shows the screw specification and Tables 8–9 are showing the recommended torque ranges for the SPM 2 (ASPM 34) Packages. Contact pressure and mounting torque may affect the thermal performance. The thermal resistance specified can be achieved with the minimum specified torque in the Table 8 and 9. Appendix 2 shows thermal resistance variance under various torque levels. Electric screwdrivers can tighten the screws with the specified torque. Considering the electrical spacing specified in Section 2.4, additional flat or spring washers can be applied on packages during mounting. Figure 16 shows SEMS (Pre-assembled washers and screw) which is a recommended screw type.

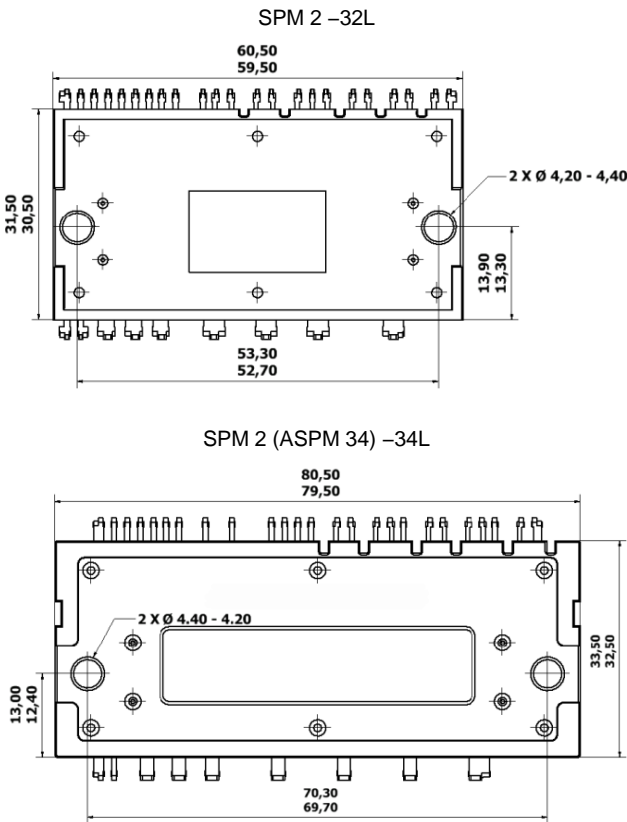

**Figure 15. Dimension of Screw Clamping Zone**

**Table 7. SCREW AND WASHER**

Parameter	Description
Mounting Screw	Metric 4 screw
Spring Washer	D = Ø 7.0 (mm) to DIN 127 or DIN 128
Plain Washer	D = Ø 9.0 (mm) to DIN 125
Recommended thread engagement for screws with property class 4.8 to 6.8 for different materials.	

**Table 8. MOUNTING TORQUE SPECIFICATION FOR SPM 2 32L**

Parameter	Min	Typ	Max	Unit
Pre-Torque	0.2		0.4	N·m
	2.0		4.1	kgf·cm
Final Torque	0.78	0.98	1.17	N·m
	8.0	10.0	12.0	kgf·cm
Generally, pre-torque is 20–30% of the final torque. Recommended final torque is 0.98 N·m.				

**Table 9. MOUNTING TORQUE SPECIFICATION FOR SPM 2 (ASPM 34) 34L**

Parameter	Min	Typ	Max	Unit
Pre-Torque	0.2		0.4	N·m
	2.0		4.1	kgf·cm
Final Torque	0.9	1.0	1.5	N·m
	9.1	10.1	15.1	kgf·cm
Generally, pre-torque is 20–30% of the final torque. Recommended final torque is 1.0 N·m.				



**Figure 16. SEMS (Pre-assembled Washers and Screw, Spring Washer Ø 7.0 and Plain Washer Ø 9.0)**

**Screw Tightening Method**

Screw tightening can be done in various ways. Figure 17 describes one recommended method for fastening the module to the heat sink. Example module is SPM 2 (ASPM 34) 34L. Fasten two screws with final torque simultaneously to prevent tilting or rising of one side of module during fastening. The recommended final torque ( $M_{torque}$ ) is in the range of 0.9–1.5 Nm (9.1– 15.1 kgf·cm), as shown in Table 8. Method 1 enables to maintain an even thermal grease layer after mounting.

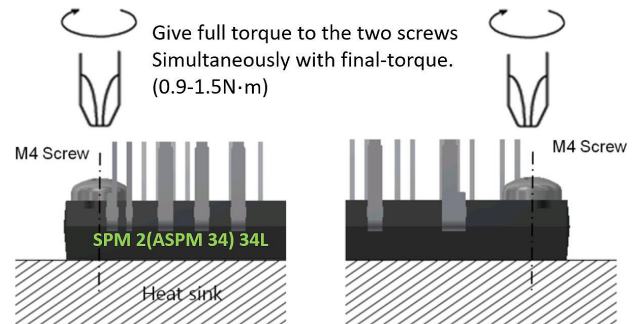

**Figure 17. Illustration of Screw Clamping with Heat Sink (Method 1)**

Alternatively, Figure 18 shows another recommended method to tighten the screws. Fasten the first screw with pre-torque to prevent one side tilting or rising of the module (Step 1). Then insert the second screw to the other side with same pre-torque (Step 2). The pre-screwing torque is set to 20~30 % of final torque rating. After that, apply full final torque to the first screw (Step 3). Finally, apply full torque to the second screw for proper mounting to the heat sink (Step 4). An insufficient tightening torque may cause an increased thermal resistance or loosening of the screws during operation.

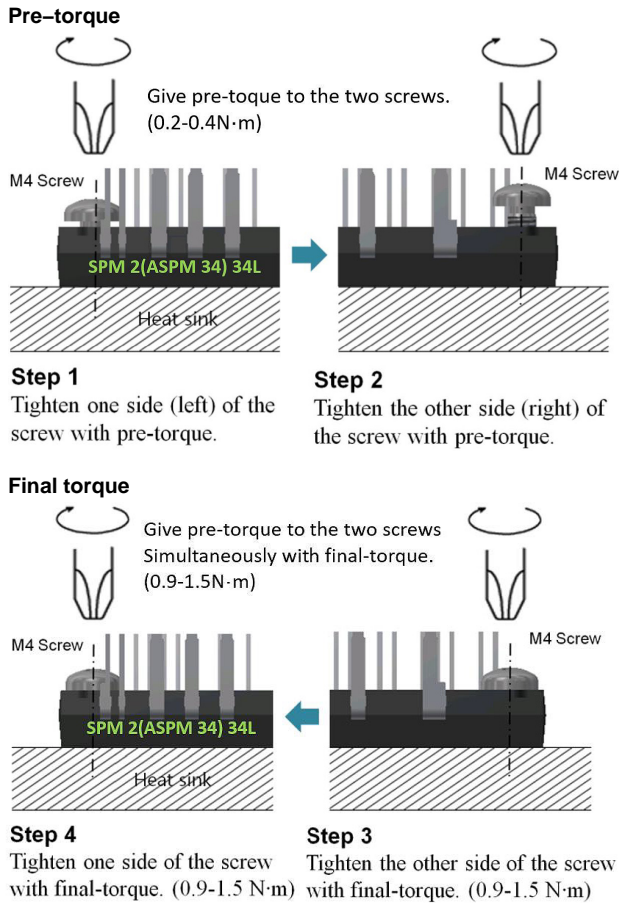

**Figure 18. Illustration of Screw Clamping with Heat Sink (Method 2)**

Note:

- Avoid applying over torque when mounting screws. Excessive fastening force may cause damages to the semiconductor devices, the package or its isolation, as well as damages to the screws or heat-sink.

- Uneven mounting can cause the SPM ceramic substrate to be damaged. A smooth surface free of burrs and protrusions or indentations is required (Table 2). No foreign materials except thermal interface materials are allowed between DBC of the module and the heat sink.
- The mounting area should be treated as a functional layer. Do not touch the mounting area of the heat sink and the substrate of the module.

**Potential Failure Modes**

The following are possible root causes of mounting failures which should be avoided during the mounting process. Table 10 lists representative examples of mounting failure mode.

- Excessive torque is applied without pre-torque
- Misalignment of screw during tightening with heat sink
- Mechanical stress by mounting height tolerances when multiple module mounted on the same PCB
- Inappropriate type of screws are used

**Table 10. EXAMPLES OF MOUNTING FAILURE MODE (VARIOUS TYPES OF SPM PACKAGES)**

Failure Mode and Cause	Example
1) EMC broken due to too high torque	
2) Package crack by abnormal heat sink flatness	
3) Ceramic crack by abnormal heat sink flatness	

**SOLDERING GUIDELINES**

Wave soldering or hand soldering are the general practice for through-hole type (THT) components. This section assesses characteristics of the soldering process for SPM 2 (ASPM 34) modules at the assembly to a PCB (Printed Circuit Board).

**Wave Soldering**

Assemblies are placed on a carrier belt moving through the soldering process contacting a solder wave. The wave soldering process typically uses a thermal profile which consists of four stages: solder fluxing, preheating zone, solder wave and cooling zone. Solder flux is either sprayed or foamed onto the components. Then the parts move to the preheating zones, normally done by convention, where the flux is activated. The assembly then moves to wave soldering and finally is getting cooled down slowly[1]. Key elements such as preheat ramp rate, conveyor speed, peak temperature and time forms a wave solder profile. The wave soldering profile should be optimized in the assembly site since it strongly depends on the equipment condition and the material type used in application. A typical soldering profile and its conditions are illustrated in Figure 19 and Table 11.

**Preheat:** Preheating is required to avoid thermal stress due to overheat. Preheat temperatures and the preheating time should be set according to the flux specification. Too high temperature and too long preheat time may break down the flux activation systems which causes shorts. On the other hand, too low preheat temperature may cause unwanted residues left on the PCB[1]. A ramp up rate between 1~4 °C per second is suggested in the preheat zone.

**Wave soldering:** Dual-wave soldering is the most common method. The 1<sup>st</sup> wave which has turbulent wave crest ensures wetting of all the land pads allowing the molten solder to find its way to all joints on the PCB. The 2<sup>nd</sup> wave, which has a laminar flow, drains the excess solder from the board after the 1<sup>st</sup> wave thus removing the solder bridges[1]. It is recommended to keep the maximum soldering temperature up to 260 °C for 10 sec to establish a good quality of the solder joint and to avoid package damage by thermal shock.

**Cooling:** Gradually cool the processed board down. A cooling down rate between 1 – 5 °C/s is recommended in general.

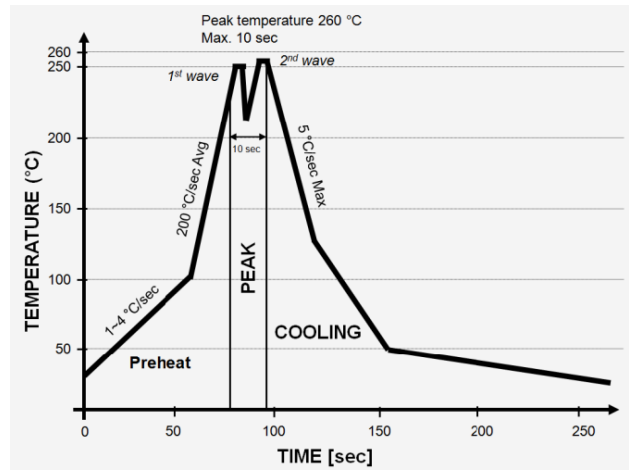

Figure 19. Typical Dual Wave Soldering Profile

Table 11. TYPICAL DUAL WAVE SOLDERING CONDITION (AT EXTERNAL TERMINALS)

Profile Feature	SnPb Eutectic Assembly	Pb-Free Assembly
Average ramp up rate	~200 °C/s	~200 °C/s
Preheat ramp up rate	Typical 1–2, max 4 °C/s	Typical 1–2, max 4 °C/s
Final preheat temp.	~130 °C/s	~130 °C/s
Peak wave soldering temperature	max 235 °C, max 10 s	max 260 °C, max 10 s
Ramp down rate	5 °C/s max	5 °C/s max

Detailed conditions of the soldering profile should be defined by users as it depends on the equipment and the materials.

**Manual Soldering**

The recommended conditions for manual soldering are listed in Table 12. Considering the glass transition temperature (T<sub>g</sub>) of the package mold resin and the thermal withstand capability of internal chips and assembly, the temperature of the terminal root part should be kept below 150 °C. Iron tip should touch the lead terminal at its tip, away from the package mold body.

Manual soldering is not recommended for mass production as it may be difficult to control the amount of solder applied and the time and temperature of the soldering step.

Table 12. EXAMPLE OF MANUAL SOLDERING CONDITION

Parameter	Single Side Circuit Board	Double/multi Layers Circuit Board
Iron tip temperature	385 ± 10 °C	420 ± 10 °C
Soldering time	2 ~ 6 seconds	4 ~ 10 seconds

**Soldering Quality Inspection**

Monitoring the soldering quality is essential since abnormal solder joints are potential risks. IPC-A-610 standard specifies the soldering quality criteria for soft soldering. For the examination of a solder joint, visual or X-ray inspection and automatic optical inspection (AOI) are suitable evaluation methods.

**APPENDIX 1**

**Thermal Performance Under Various Mounting Torque [3]**

Since the module surface and heat sink are not perfectly flat, contact pressure and mounting torque can affect thermal performance. AN-9079 shows a correlation between the mounting torque and the thermal resistance for a 1200 V Motion SPM 2 (ASPM34) module. According to the results shown in Figure 20, higher thermal resistance values (Rthjc) were measured at low torque levels ranging between 1~4 (kg-f-cm) while the thermal resistance reaches lower and stable values above 5 (kg-f-cm) torque.

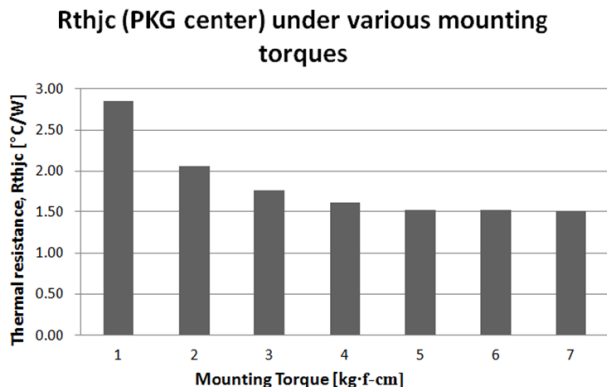

**Figure 20. Thermal Resistance under Various Mounting Torque**

**Literature**

- [1] AN-5082, “Power56 Wave-Soldering Board Assembly Considerations,” 2015, Fairchild
- [2] SARVAR,F., WHALLEY, “Thermal interface materials– a review of the state of the art”, September 2006
- [3] IPC-A-610-D, “Acceptance of Electronic Assemblies,” February 2005
- [4] IPC J-STD-001D, “Requirements for Soldered Electrical and Electronic Assemblies.”
- [5] IPC-SM-7525A, “Stencil Design Guidelines,” May 2000
- [6] JEDEC, JESD22-B102D, “Solderability,” VA, Sept. 2004

**Related Datasheets**

- [FSAM10SH60A/D](#)
- [FSAM15SH60A/D](#)
- [FSAM20SH60A/D](#)
- [FSAM30SH60A/D](#)
- [FSAM20SM60A/D](#)
- [FSAM30SM60A/D](#)
- [FSAM50SM60A/D](#)
- [FSAM75SM60A/D](#)
- [FNA23060/D](#)
- [FNA25060/D](#)
- [FNA27560/D](#)
- [FNA21012A/D](#)
- [FNA22512A/D](#)
- [FNA23512A/D](#)
- [FNA25012A/D](#)
- [NFVA22512NP2T/D](#)
- [NFVA23512NP2T/D](#)
- [NFVA25012NP2T/D](#)

ON Semiconductor and are trademarks of Semiconductor Components Industries, LLC dba ON Semiconductor or its subsidiaries in the United States and/or other countries. ON Semiconductor owns the rights to a number of patents, trademarks, copyrights, trade secrets, and other intellectual property. A listing of ON Semiconductor’s product/patent coverage may be accessed at [www.onsemi.com/site/pdf/Patent-Marking.pdf](http://www.onsemi.com/site/pdf/Patent-Marking.pdf). ON Semiconductor reserves the right to make changes without further notice to any products herein. ON Semiconductor makes no warranty, representation or guarantee regarding the suitability of its products for any particular purpose, nor does ON Semiconductor assume any liability arising out of the application or use of any product or circuit, and specifically disclaims any and all liability, including without limitation special, consequential or incidental damages. Buyer is responsible for its products and applications using ON Semiconductor products, including compliance with all laws, regulations and safety requirements or standards, regardless of any support or applications information provided by ON Semiconductor. “Typical” parameters which may be provided in ON Semiconductor data sheets and/or specifications can and do vary in different applications and actual performance may vary over time. All operating parameters, including “Typicals” must be validated for each customer application by customer’s technical experts. ON Semiconductor does not convey any license under its patent rights nor the rights of others. ON Semiconductor products are not designed, intended, or authorized for use as a critical component in life support systems or any FDA Class 3 medical devices or medical devices with a same or similar classification in a foreign jurisdiction or any devices intended for implantation in the human body. Should Buyer purchase or use ON Semiconductor products for any such unintended or unauthorized application, Buyer shall indemnify and hold ON Semiconductor and its officers, employees, subsidiaries, affiliates, and distributors harmless against all claims, costs, damages, and expenses, and reasonable attorney fees arising out of, directly or indirectly, any claim of personal injury or death associated with such unintended or unauthorized use, even if such claim alleges that ON Semiconductor was negligent regarding the design or manufacture of the part. ON Semiconductor is an Equal Opportunity/Affirmative Action Employer. This literature is subject to all applicable copyright laws and is not for resale in any manner.

**PUBLICATION ORDERING INFORMATION**

**LITERATURE FULFILLMENT:**  
 Email Requests to: [orderlit@onsemi.com](mailto:orderlit@onsemi.com)

**TECHNICAL SUPPORT**  
**North American Technical Support:**  
 Voice Mail: 1 800-282-9855 Toll Free USA/Canada  
 Phone: 011 421 33 790 2910

**Europe, Middle East and Africa Technical Support:**  
 Phone: 00421 33 790 2910  
 For additional information, please contact your local Sales Representative

**ON Semiconductor Website:** [www.onsemi.com](http://www.onsemi.com)