

# **MIH400HC-AA**

## *Indirect Fired Heat Cart*

### *Owner's Manual*

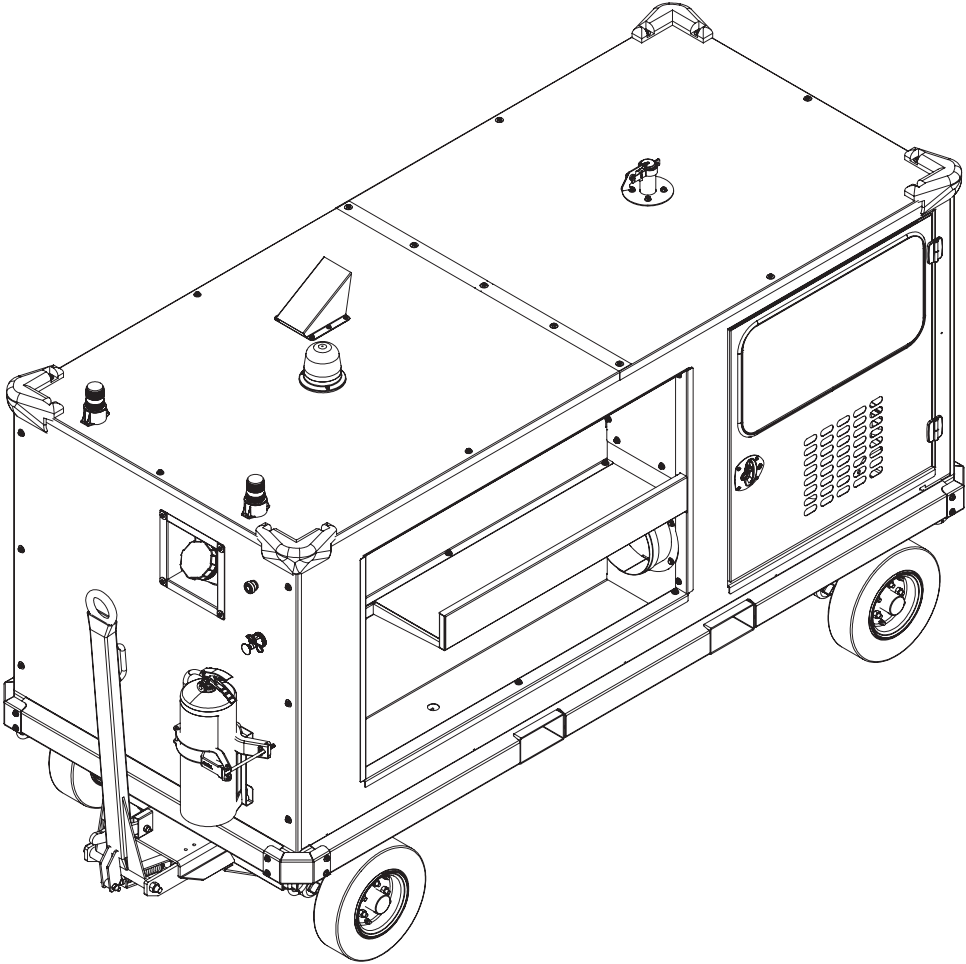

**MODEL NUMBER:** \_\_\_\_\_

**SERIAL NUMBER:** \_\_\_\_\_

**DATE PURCHASED:** \_\_\_\_\_

---

**⚠ WARNING**

Operating, servicing and maintaining this equipment can expose you to chemicals including engine exhaust, carbon monoxide, phthalates, and lead, which are known to the State of California to cause cancer and birth defects or other reproductive harm. To minimize exposure, avoid breathing exhaust, do not idle the engine except as necessary, service your equipment in a well-ventilated area and wear gloves or wash your hands frequently when servicing your equipment. For more information go to [www.P65Warnings.ca.gov](http://www.P65Warnings.ca.gov). (000393)

**⚠ WARNING**

Breathing diesel engine exhaust exposes you to chemicals known to the State of California to cause cancer and birth defects or other reproductive harm.

- Always start and operate the engine in a well-ventilated area.
- If in an enclosed area, vent the exhaust to the outside.
- Do not modify or tamper with the exhaust system.
- Do not idle the engine except as necessary.

For more information go to [www.P65Warnings.ca.gov/diesel](http://www.P65Warnings.ca.gov/diesel). (000394)

# Table of Contents

## **Section 1: Introduction and Safety**

<b>Introduction</b> .....	<b>1</b>
Read This Manual Thoroughly .....	1
<b>Safety Rules</b> .....	<b>1</b>
How to Obtain Service .....	1
<b>General Hazards</b> .....	<b>2</b>
<b>Explosion and Fire Hazards</b> .....	<b>2</b>
<b>Trailer Hazards</b> .....	<b>3</b>
<b>Battery Hazards</b> .....	<b>3</b>
<b>Service Safety</b> .....	<b>3</b>
<b>Safety and Operating Decals</b> .....	<b>4</b>

## **Section 2: General Information**

<b>Specifications</b> .....	<b>9</b>
<b>Exterior Components</b> .....	<b>10</b>
<b>Engine Components</b> .....	<b>11</b>
<b>Burner Components</b> .....	<b>12</b>
<b>Control Panel Components</b> .....	<b>13</b>
Engine Controller .....	14
Monitoring, Diagnostic, and Protective Features .....	14
<b>Emissions Information</b> .....	<b>14</b>
<b>Engine Oil Recommendations</b> .....	<b>14</b>
<b>Coolant Recommendations</b> .....	<b>14</b>
<b>Fuel System</b> .....	<b>14</b>
<b>Cart Towing Guidelines</b> .....	<b>15</b>
Parking Brake Use .....	16
<b>Engine Block Heater</b> .....	<b>16</b>
<b>Burner</b> .....	<b>16</b>
<b>Rooftop Beacons</b> .....	<b>16</b>
<b>Carbon Monoxide Alarms</b> .....	<b>16</b>

## **Section 3: Operation**

<b>Theory of Operation</b> .....	<b>17</b>
<b>Before Starting Engine</b> .....	<b>17</b>
Pre-start Checklist .....	17
Engine Oil Level Check .....	17
Engine Coolant Check .....	18
<b>Ducting Guidelines</b> .....	<b>18</b>
<b>Engine and Heater Startup</b> .....	<b>18</b>
<b>Engine and Heater Shutdown</b> .....	<b>19</b>
<b>Emergency Stop</b> .....	<b>19</b>

<b>Thermostats</b> .....	<b>20</b>
Overview .....	20
Changing Temperature Units .....	20
Viewing and Adjusting Temperature Set Point .....	20
Thermostat Control .....	20
<b>Fire Suppression System</b> .....	<b>21</b>
Automatic Activation .....	21
Manual Activation .....	21
Recharging System .....	21

## **Section 4: Maintenance**

<b>Maintenance</b> .....	<b>23</b>
<b>Maintenance Tasks</b> .....	<b>23</b>
Daily Walk Around Inspection .....	23
Draining and Refilling the Oil .....	23
Adding Coolant .....	24
Fire Suppression System .....	24
<b>Maintenance Schedule</b> .....	<b>24</b>
Maintenance Schedule .....	25
<b>Battery Inspection</b> .....	<b>26</b>
Battery Installation and Replacement .....	26
<b>Other Maintenance Checks</b> .....	<b>27</b>
<b>Storing the Unit</b> .....	<b>27</b>
Short Term Storage .....	27
Long Term Storage .....	27
Return to Service .....	27

## **Section 5: Troubleshooting**

<b>General Troubleshooting Guide</b> .....	<b>29</b>
<b>Burner Troubleshooting</b> .....	<b>35</b>

## **Section 6: Installation Diagrams and Service Log**

<b>Control Box Wiring Diagram (1 of 3)</b> .....	<b>37</b>
<b>Control Box Wiring Diagram (2 of 3)</b> .....	<b>38</b>
<b>Control Box Wiring Diagram (3 of 3)</b> .....	<b>39</b>
<b>Service Log</b> .....	<b>40</b>

---

**This page intentionally left blank.**

# Section 1: Introduction and Safety

## Introduction

Thank you for purchasing a Generac Mobile Products LLC product. This unit has been designed to provide high-performance, efficient operation, and years of quality use when maintained properly.

The MIH400HC indirect fired heat cart is designed and built for sustained, reliable heat production in industrial operating conditions and environments. The MIH400HC is built to withstand frequent handling under these conditions.

The unit has forklift access and chain attach points on both sides. The fully enclosed design protects the operating components, allowing all-weather storage and operations.

The information in this manual is accurate based on products produced at the time of publication. The manufacturer reserves the right to make technical updates, corrections, and product revisions at any time without notice.

## Read This Manual Thoroughly



Consult Manual. Read and understand manual completely before using product. Failure to completely understand manual and product could result in death or serious injury. (000100a)

If any section of the manual is not understood, contact your nearest Generac Mobile Products (GMP) Authorized Service Dealer (ASD), or contact Generac Mobile Products Customer Service at 800-926-9768, or visit [www.generacmobileproducts.com](http://www.generacmobileproducts.com) with any questions or concerns.

The owner is responsible for proper maintenance and safe use of the equipment.

SAVE THESE INSTRUCTIONS for future reference. This manual contains important instructions for the unit that should be followed during installation, operation, and maintenance of the heater and batteries. ALWAYS supply this manual to any individual that will use this machine.

## Safety Rules

The manufacturer cannot anticipate every possible circumstance that might involve a hazard. The alerts in this manual, and on tags and decals affixed to the unit, are not all inclusive. If using a procedure, work method, or operating technique that the manufacturer does not specifically recommend, verify that it is safe for others and does not render the equipment unsafe.

Throughout this publication, and on tags and decals

affixed to the unit, DANGER, WARNING, CAUTION, and NOTE blocks are used to alert personnel to special instructions about a particular operation that may be hazardous if performed incorrectly or carelessly. Observe them carefully. Alert definitions are as follows:



Indicates a hazardous situation which, if not avoided, will result in death or serious injury.

(000001)



Indicates a hazardous situation which, if not avoided, could result in death or serious injury.

(000002)



Indicates a hazardous situation which, if not avoided, could result in minor or moderate injury.

(000003)

**NOTE:** Notes contain additional information important to a procedure and will be found within the regular text of this manual.

These safety alerts cannot eliminate the hazards that they indicate. Common sense and strict compliance with the special instructions while performing the action or service are essential to preventing accidents.

## How to Obtain Service

When the unit requires servicing or repairs, contact a GMP ASD for assistance. Service technicians are factory-trained and are capable of handling all service needs. Go to <https://www.generacmobileproducts.com/parts-service/find-service> for assistance locating a dealer.

When contacting a GMP ASD about parts and service, always supply the complete model and serial number of the unit as given on its data decal located on the unit. Record the model and serial numbers in the spaces provided on the inside front cover of this manual.

## General Hazards



### ⚠ DANGER

Asphyxiation. Running engines produce carbon monoxide, a colorless, odorless, poisonous gas. Carbon monoxide, if not avoided, will result in death or serious injury. (000103)



### ⚠ DANGER

Asphyxiation. Do not operate unit without a properly functioning exhaust system. Doing so will result in death or serious injury. (000340)

### ⚠ WARNING

Personal injury. Do not operate unit during transport. Doing so could result in death, serious injury, or property damage. (000231a)



### ⚠ WARNING

Hearing Loss. Hearing protection is recommended when using this machine. Failure to wear hearing protection could result in permanent hearing loss. (000107)



### ⚠ WARNING

Moving Parts. Keep clothing, hair, and appendages away from moving parts. Failure to do so could result in death or serious injury. (000111)



### ⚠ WARNING

Hot Surfaces. When operating machine, do not touch hot surfaces. Keep machine away from combustibles during use. Hot surfaces could result in severe burns or fire. (000108)

### ⚠ WARNING

Equipment damage. Do not attempt to start or operate a unit in need of repair or scheduled maintenance. Doing so could result in serious injury, death, or equipment failure or damage. (000291)

### ⚠ CAUTION

Equipment or property damage. Do not block air intake or restrict proper air flow. Doing so could result in unsafe operation or damage to unit. (000229)

### ⚠ CAUTION

Unit damage. Do not stop engine before heating unit is cooled. Doing so could result in unit damage. (000240a)

### ⚠ CAUTION

Equipment Damage. The emergency stop switch is not to be used to power down the unit under normal operating circumstances. Doing so will result in equipment damage. (000246)

### ⚠ CAUTION

Equipment damage. Shut down the heater before turning off the generator. Failure to do so could result in equipment damage. (000295)

## Explosion and Fire Hazards



### ⚠ DANGER

Explosion and Fire. Fuel and vapors are extremely flammable and explosive. Add fuel in a well ventilated area. Keep fire and spark away. Failure to do so will result in death or serious injury. (000105)



### ⚠ DANGER

Explosion and Fire. Fuel and vapors are extremely flammable and explosive. Store fuel in a well ventilated area. Keep fire and spark away. Failure to do so will result in death or serious injury. (000143)



### ⚠ DANGER

Explosion and Fire. Do not overfill fuel tank. Overfilling may cause fuel to leak and ignite or explode, resulting in death or serious injury. (000204)

**WARNING**

Risk of Fire. Unit must be positioned in a manner that prevents combustible material accumulation underneath. Failure to do so could result in death or serious injury. (000147)

**WARNING**

Fire risk. Fuel and vapors are extremely flammable. Do not operate indoors. Doing so could result in death, serious injury, or property or equipment damage. (000281)

**WARNING**

Explosion and fire risk. Do not smoke near unit. Keep fire and spark away. Failure to do so could result in death, serious injury, or property or equipment damage. (000282)

## Trailer Hazards

**WARNING**

Crushing hazard. Verify parking brake is properly secured and unit is on level ground. An unsecured unit could suddenly roll or move, and could result in death, serious injury, or equipment damage. (000352)

**WARNING**

Property or Equipment Damage. Tighten wheel lug nuts every 30 days to factory specifications. Failure to do so could result in death, serious injury, or property or equipment damage. (000364)

**WARNING**

Control loss. Trailer must be securely coupled to the hitch. An incorrectly coupled trailer could result in loss of control, death, or serious injury. (000360)

**WARNING**

Personal injury. Do not operate unit during transport. Doing so could result in death, serious injury, or property damage. (000231a)

## Battery Hazards

**WARNING**

Explosion. Batteries emit explosive gases while charging. Keep fire and spark away. Wear protective gear when working with batteries. Failure to do so could result in death or serious injury. (000137a)

**WARNING**

Explosion. Do not dispose of batteries in a fire. Batteries are explosive. Electrolyte solution can cause burns and blindness. If electrolyte contacts skin or eyes, flush with water and seek immediate medical attention. (000162)

**WARNING**

Risk of burn. Do not open or mutilate batteries. Batteries contain electrolyte solution which can cause burns and blindness. If electrolyte contacts skin or eyes, flush with water and seek immediate medical attention. (000163a)

**WARNING**

Accidental start-up. Disconnect negative battery terminal before servicing to prevent accidental engine rotation. Failure to do so could result in death or serious injury. (000148a)

**WARNING**

Environmental Hazard. Always recycle batteries at an official recycling center in accordance with all local laws and regulations. Failure to do so could result in environmental damage, death or serious injury. (000228)

Always recycle batteries in accordance with local laws and regulations. Contact your local solid waste collection site or recycling facility to obtain information on local recycling processes. For more information on battery recycling, visit the Battery Council International website at: <http://batteryCouncil.org>

## Service Safety

- **DO NOT** perform even routine service (oil/filter changes, cleaning, etc.) unless all electrical components are shut down.
- Replace all missing and hard to read decals. Decals provide important operating instructions and warn of dangers and hazards.
- Wear all task-appropriate PPE when completing maintenance or service tasks.

## Safety and Operating Decals

See [Figure 1-1](#) through [Figure 1-3](#). This unit features numerous safety and operating decals. These decals provide important operating instructions and warn of dangers and hazards. The following diagrams illustrate

decal locations and descriptions. Replace any missing or hard-to-read decals and use care when washing or cleaning the unit. Decal part numbers can be found in the unit parts manual at [www.generacmobileproducts.com](http://www.generacmobileproducts.com).

ID	Description	ID	Description
1	Warning—Hot Surface	12	Operating Instructions
2	Tie Down Location	13	Ultra Low Sulfur Fuel Only
3	Keep Doors Closed During Operation	14	Danger—Diesel Fuel
4	Fork Lift Tubes	15	Fire Suppression Instructions
5	Warning—Do Not Remove Guard, Cutting Hazard	16	Emergency Stop
6	Fuel Return Line	17	Fire Extinguisher Only
7	Fuel Supply Line	18	Fire Extinguisher Only (Surround)
8	Heater Fuel Filter	19	Engine Block Heater Input
9	Air Duct Storage	20	No Step
10	Electrical Shock Hazard	21	Parking Brake Instructions
11	Battery Disconnect Switch	22	Towing Speed Limit



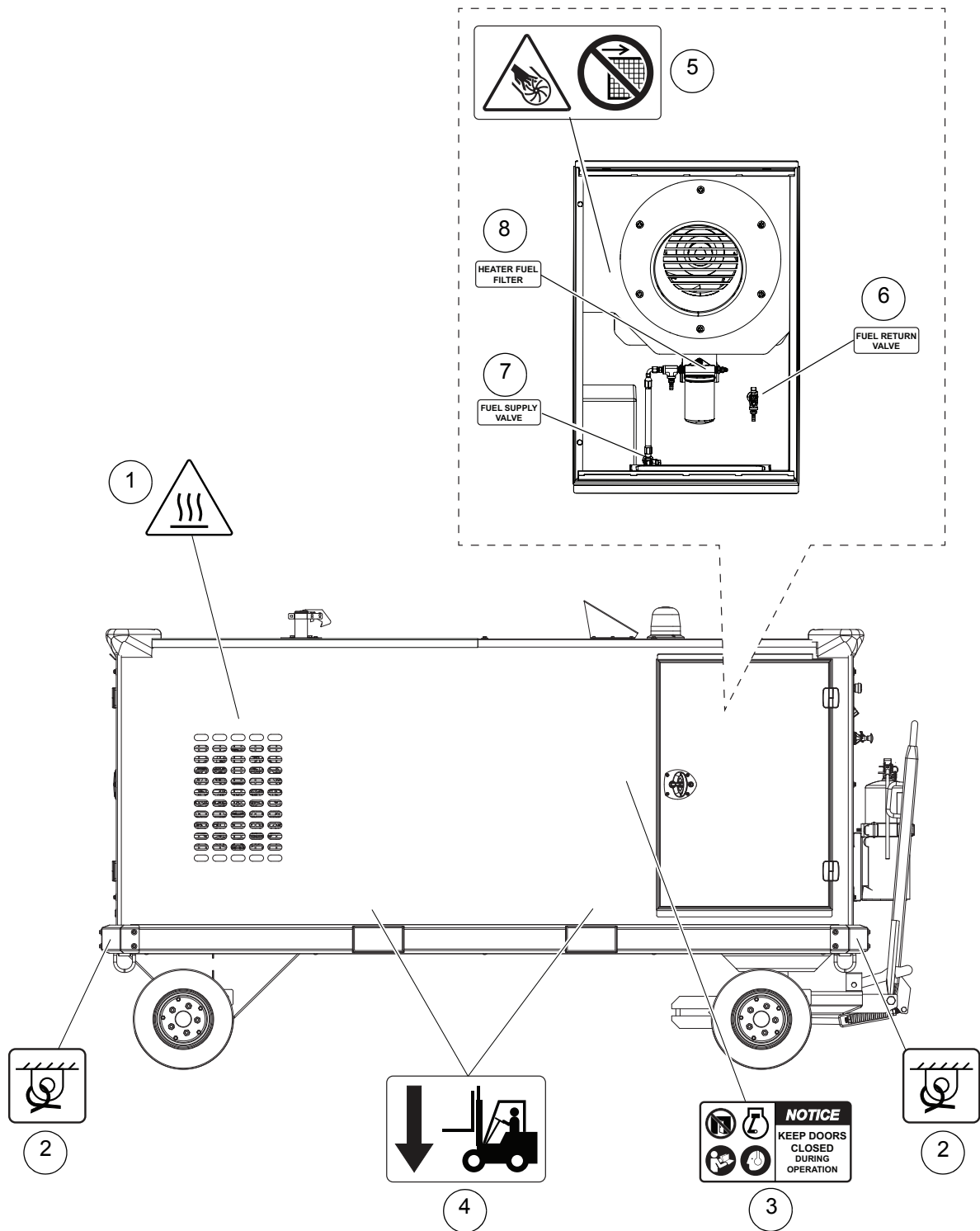

Figure 1-1. Safety Decals

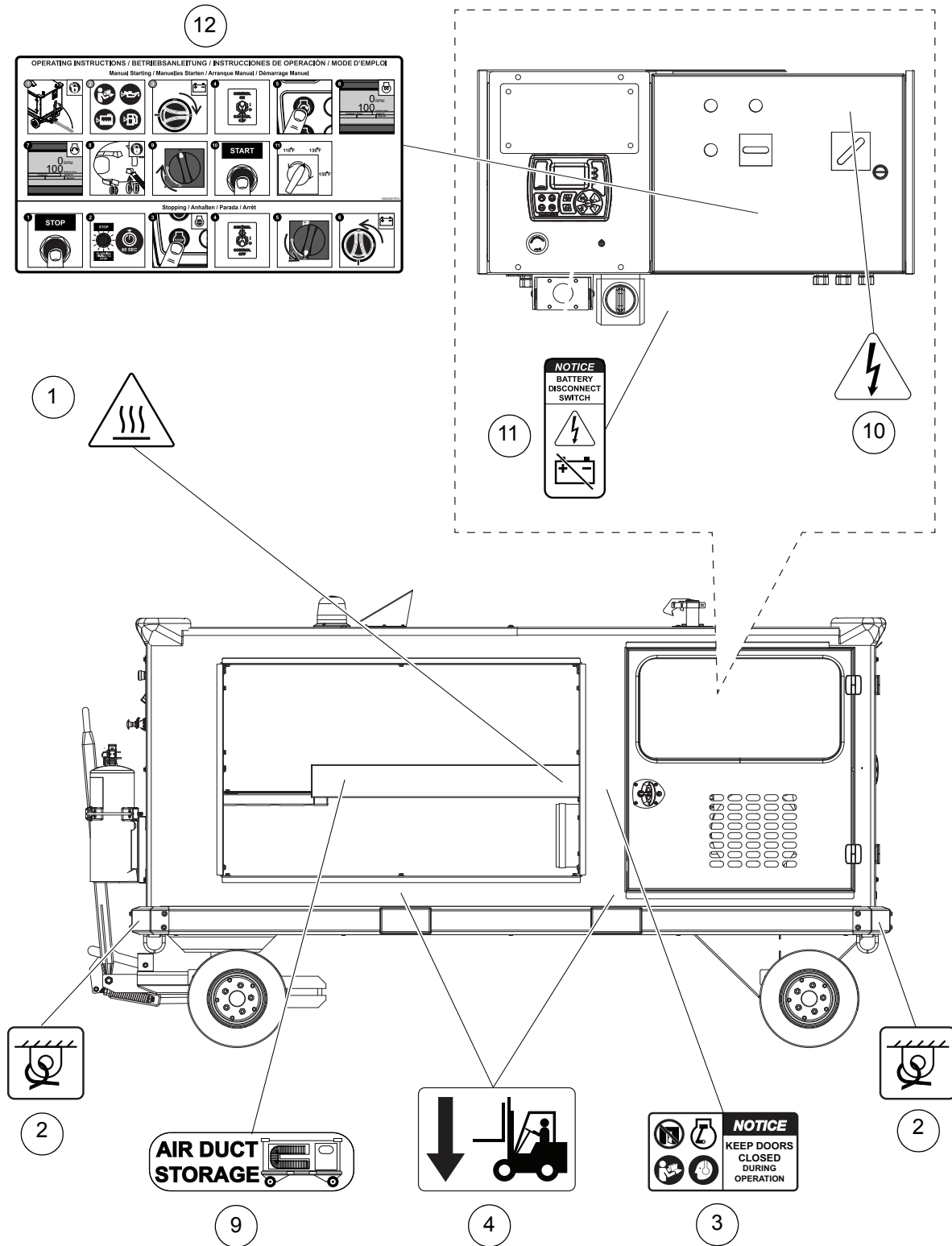

Figure 1-2. Safety Decals

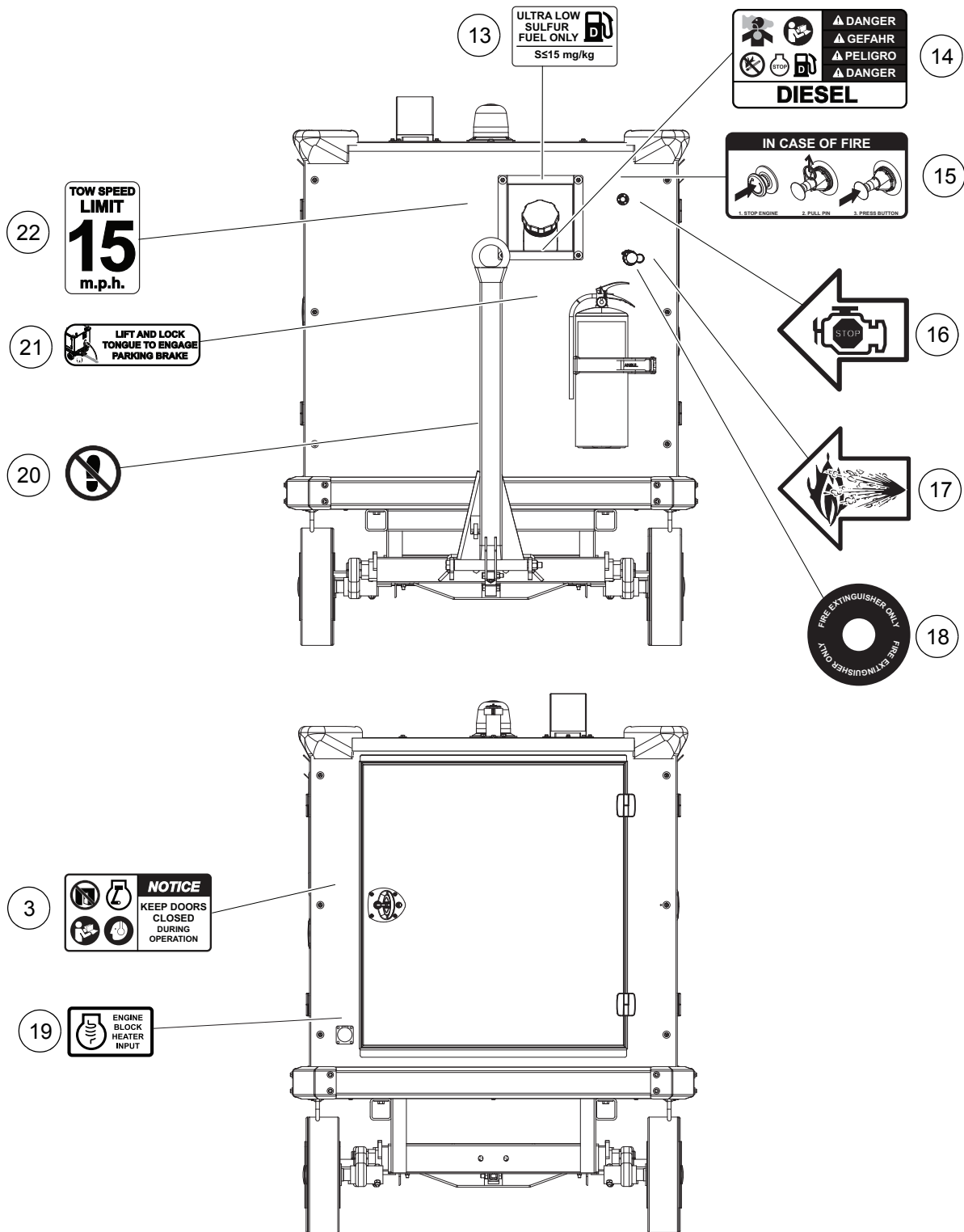

Figure 1-3. Safety Decals

**This page intentionally left blank.**

## Section 2: General Information

### Specifications

Heater	400,000 BTU/hour (117.2 kW/hour) maximum
Type	Indirect fired
Power	ISUZU 3CE1 Tier 4 Final diesel, 23.4 hp (17.4 kW)
Operating Speed	1,800 rpm
Engine Controls/Display	Murphy MPC-10
Air Volume	3,600 CFM (101.94 m <sup>3</sup> /min)
Battery	GRP 24 720 CCA
Static Pressure	9 in H <sub>2</sub> O (22.8 mm H <sub>2</sub> O)
Air Outlet	12 in (30.5 cm)
Electrical	12V
Engine Fuel	Diesel
Engine Fuel Capacity	52 gal (197 L)
Engine Oil Capacity	7 qt (6.7 L)
Engine Coolant Capacity (total system, including radiator)	5.5 qt (5.2 L)
Engine Fuel Rate (at 100% prime)	1.25 gph (4.76 Lph)
Burner Fuel Rate (at 100% prime)	3.39 gph (12.8 Lph)
Total Maximum Run Time	18 hrs
Temperature Rise	180 °F (82 °C)
Fan	Class 22, RBA-909
Hitch Type	Pintle ring
Tire Size	4 in x 8 in (10.2 cm x 20.3 cm)
Lug Nut Torque	100 ft-lbs (135.6 Nm)
Ducting Length	30 ft (9.1 m)
Estimated Heater Efficiency	85%
Dimensions	168.5 in x 50 in x 72 in (427.9 cm x 127 cm x 182.9 cm)
Weight	4,445 lbs (2,041 kg) operating weight
Burner	Riello R40 F10
Generator	Marathon 282PSL1704
Generator Output	12 kW
Fire Suppression System	ANSUL <sup>®</sup> LVS Checkfire 110

## Exterior Components

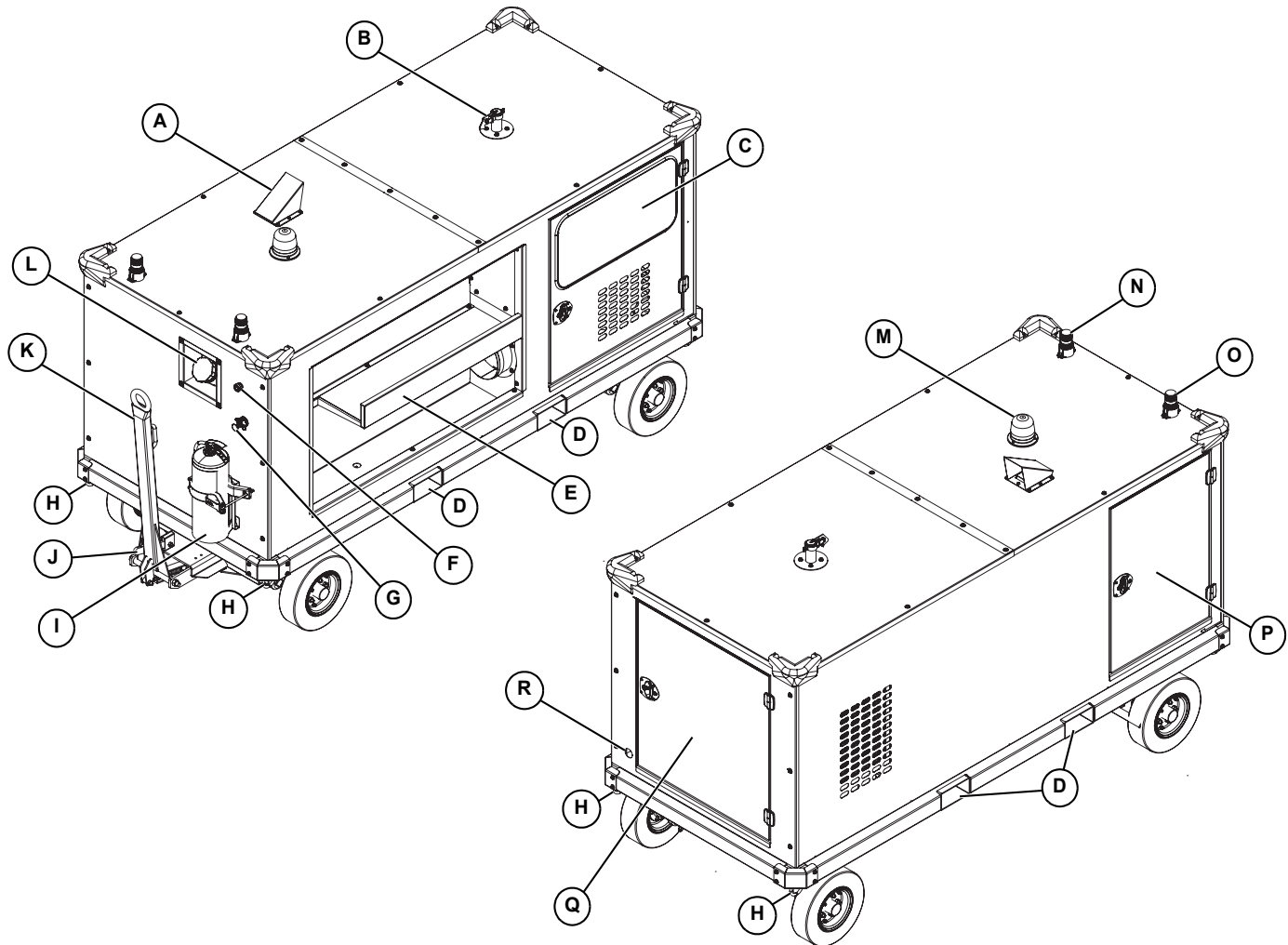

**Figure 2-1. Exterior Components**

- |   |                                |   |                                |
|---|--------------------------------|---|--------------------------------|
| A | Burner exhaust                 | J | Parking brake                  |
| B | Engine exhaust                 | K | Tow bar                        |
| C | Control panel access door      | L | Fuel fill                      |
| D | Fork lift pocket               | M | Engine operation beacon        |
| E | Ducting storage                | N | Low fuel beacon                |
| F | Emergency STOP switch          | O | Operating temperature beacon   |
| G | Fire suppression system switch | P | Burner/blower access door      |
| H | Tie-down ring                  | Q | Engine access door             |
| I | Fire extinguisher              | R | Engine block heater connection |

## Engine Components

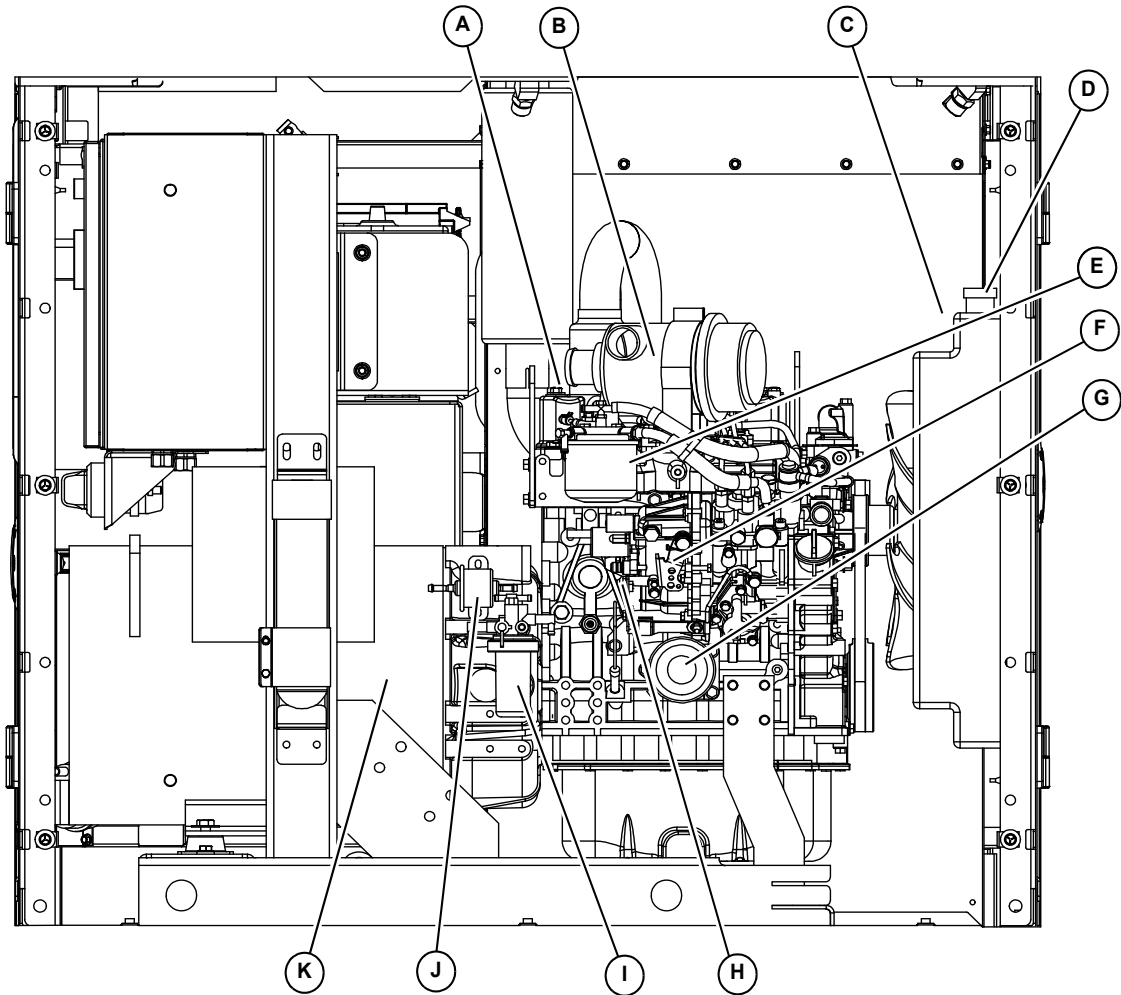

**Figure 2-2. Engine Components**

- |   |                              |   |                               |
|---|------------------------------|---|-------------------------------|
| A | Engine oil fill              | G | Engine oil filter             |
| B | Air cleaner assembly         | H | Engine oil dipstick           |
| C | Coolant sub-tank (not shown) | I | Fuel/water separator assembly |
| D | Engine radiator cap          | J | Engine fuel pump              |
| E | Engine fuel filter           | K | Generator                     |
| F | Governor lever               |   |                               |

## Burner Components

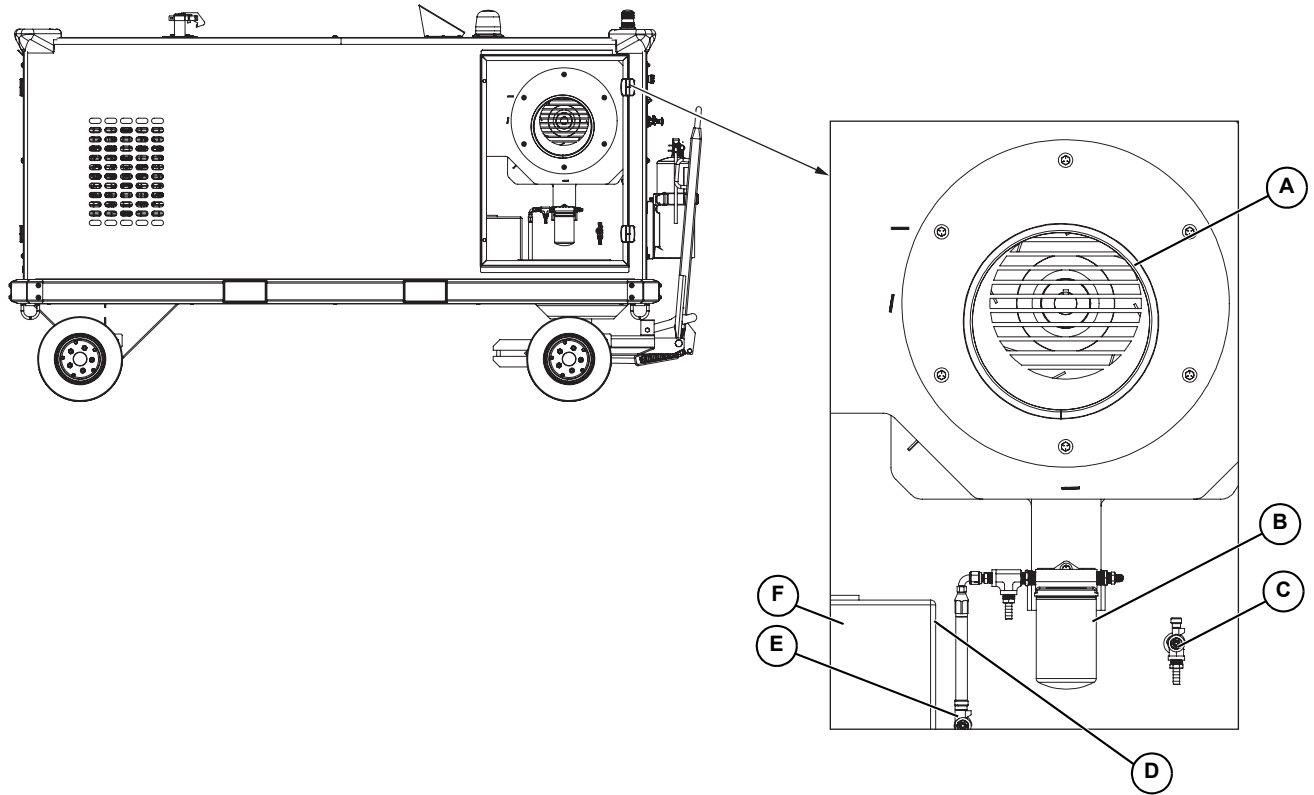
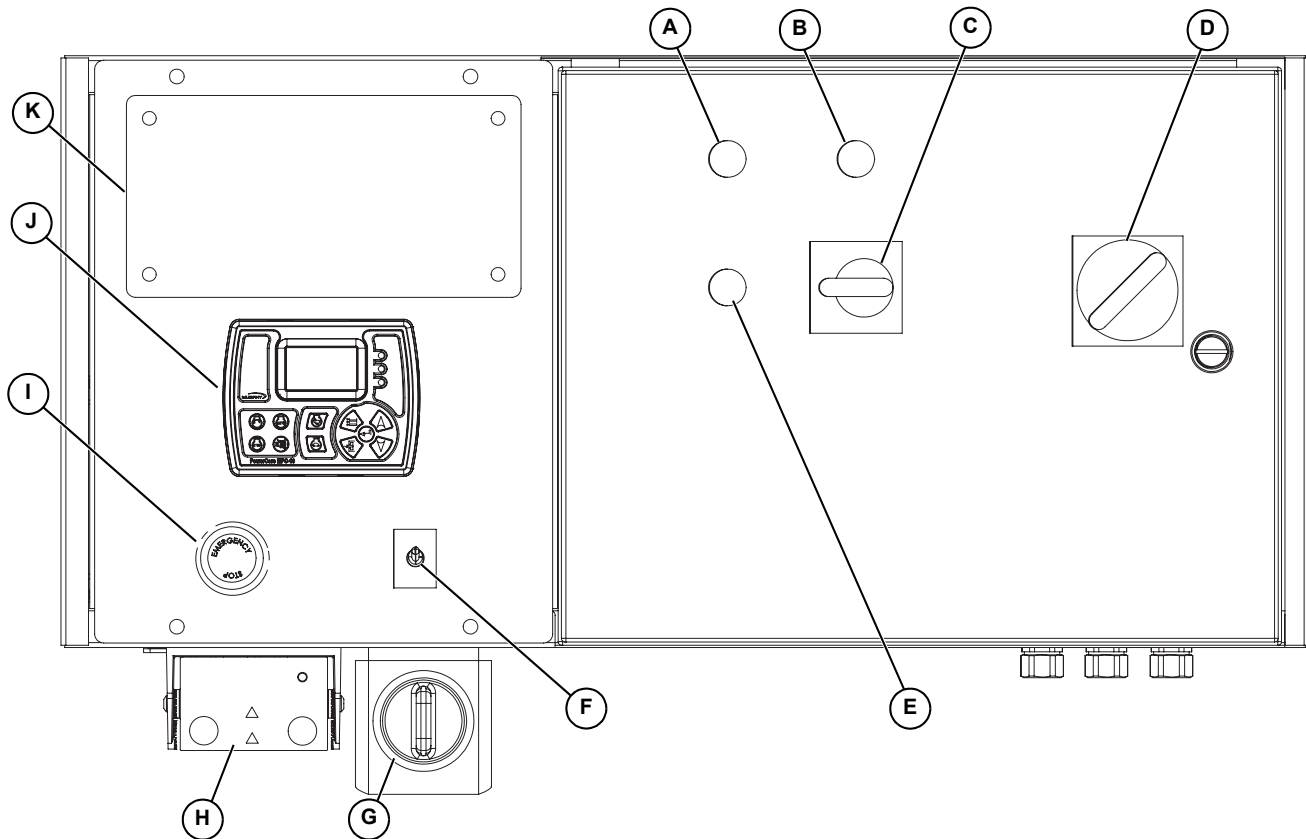

**Figure 2-3. Burner Components**

- |   |                      |   |                     |
|---|----------------------|---|---------------------|
| A | Blower fan and motor | D | Burner reset button |
| B | Burner fuel filter   | E | Fuel supply valve   |
| C | Fuel return valve    | F | Diesel fired burner |



## Control Panel Components



**Figure 2-4. Control Panel Components**

- |   |                             |   |                                     |
|---|-----------------------------|---|-------------------------------------|
| A | Burner START button         | G | Battery disconnect switch           |
| B | Burner STOP button          | H | ANSUL Checkfire 110 Control System* |
| C | Temperature select switch   | I | Emergency STOP switch               |
| D | Main circuit breaker switch | J | Engine controller                   |
| E | LOW TEMP light              | K | Thermostat access panel             |
| F | Controller power switch     |   |                                     |

\*See OEM documentation included in packet

## Engine Controller

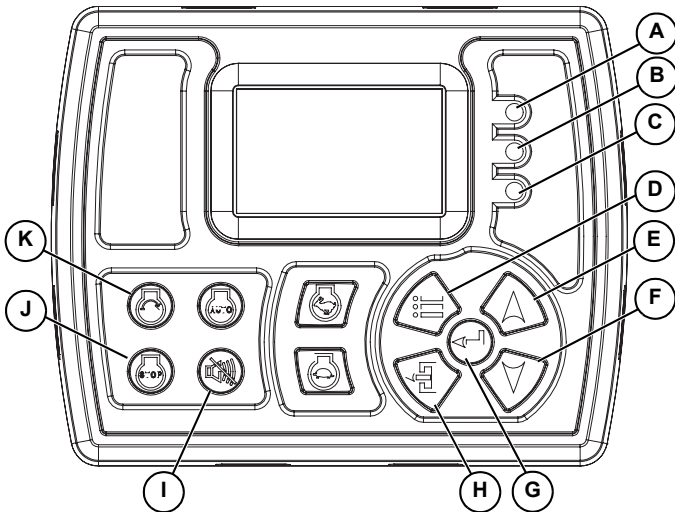

Figure 2-5. Engine Controller

### Unit Status Indicator Lights

- A Red: Shut-down state
- B Yellow: Warning state
- C Green: *Auto* mode or running loaded

### Buttons

- D Menu
- E Up
- F Down
- G Enter
- H Back
- I Alarm silence
- J Stop
- K Start

### Monitoring, Diagnostic, and Protective Features

The unit's mechanical and electrical systems are connected to various sensors that monitor unit status. If conditions occur outside of predetermined manufacturing parameters, the controller will automatically stop the machine and display fault information. The controller can also display a variety of critical alerts, diagnostics, and recommendations. The controller provides a variety of real-time current operation condition data. For more information, see the engine harness wiring diagram.

### Emissions Information

For emissions information, see the diesel engine OEM manual.

## Engine Oil Recommendations

Change oil and oil filter at least once every 12 months, even if the hours of operation are fewer than the otherwise recommended service interval. See the diesel engine OEM manual for recommended oil types.

For more information, see the engine manual.

## Coolant Recommendations



**DANGER**

Risk of poisoning. Do not use mouth to siphon coolant. Doing so will result in death or serious injury.

(000149)

**CAUTION**

Engine damage. Use approved coolant only. Failure to do so could result in equipment damage.

(000323)

Use demineralized or distilled water for best results. Hard water causes scale deposits, which reduces cooling efficiency and raises internal temperatures, possibly leading to engine damage.

Use a Long Life Coolant Antifreeze or Extended Life Coolant that meets or exceeds these specifications:

- Isuzu Part Number 8-12346-290-0
- ASTM D4985

See the engine manual for recommended coolants.

Test coolant yearly, or every 1,000 hours, whichever comes first.

For more information, see the engine manual.

## Fuel System



**DANGER**

Explosion and Fire. Fuel and vapors are extremely flammable and explosive. Keep fire and spark away. Failure to do so will result in death or serious injury.

(000168)



**DANGER**

Explosion and Fire. Do not overfill fuel tank. Overfilling may cause fuel to leak and ignite or explode, resulting in death or serious injury.

(000204)

The heater is designed to operate with diesel fuel.

**IMPORTANT NOTE: Comply with all laws regulating the storage and handling of fuels.**

Follow these guidelines:

- Use only ultra-low-sulfur diesel (ULSD) fuel.
- When temperatures are at or below freezing, use No. 1D diesel fuel.
- When temperatures are above freezing, use No. 2D diesel fuel.
- In some areas of the country, climatized fuel—a mixture of 1D and 2D—may also be used.

For more information, see the engine manual.

**Cart Towing Guidelines**

Control loss. Trailer must be securely coupled to the hitch. An incorrectly coupled trailer could result in loss of control, death, or serious injury.

(000360)



Property or Equipment Damage. Tighten wheel lug nuts every 30 days to factory specifications. Failure to do so could result in death, serious injury, or property or equipment damage.

(000364)

**IMPORTANT NOTE: Do not exceed 15 mph (24 km/h).**

The front axle is steered by a tow bar with a pintle ring hitch. It is equipped with a mechanical parking brake activated by raising the tow bar to the locked position.

**NOTE:** See the tow vehicle manual for coupling instructions.

Driving a vehicle with a cart in tow is vastly different than driving the same vehicle without a cart in tow. Consider the following:

- It takes longer to get up to speed.
- More room is needed to turn.
- More distance is needed to stop.
- The driver is responsible for keeping the vehicle and cart in control, and for all damage caused if control is lost.

Before towing, verify the following:

- The coupling, tires, and wheels are in working order.
- Wheel lug nuts are tightened to 100 ft-lbs (135.6 Nm).

**IMPORTANT NOTE:** See [Figure 2-6](#). *Wheel lug nuts are the five inner lug nuts (A), or those closest to the wheel hub.*

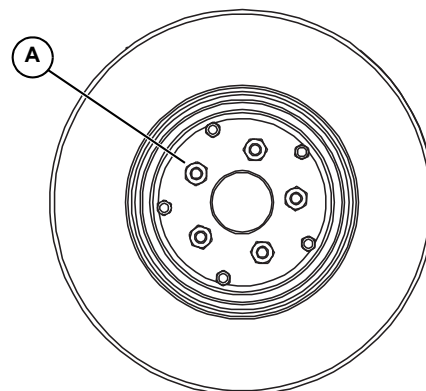

**Figure 2-6. Wheel Lug Nuts**

While towing, make regular stops to verify the following:

- Coupler is secured to the hitch and locked.
- No damage or unusual wear to tire treads or sidewalls.
- Cart and doors are latched and secured.

## Parking Brake Use

### ⚠️ WARNING

Crushing hazard. Verify parking brake is properly secured and unit is on level ground. An unsecured unit could suddenly roll or move, and could result in death, serious injury, or equipment damage. (000352)



### ⚠️ CAUTION

Pinching and crushing hazard. To avoid possible injury, keep fingers away from pivot point when folding or unfolding trailer tongue. (000313)

See [Figure 2-7](#). Engage parking brake by raising tow bar to locked position. Locking lever (A) holds the tow bar in place. Do not operate unit without the parking brake engaged.

Lift up locking lever and slowly lower tow bar to disengage parking brake. Do not attempt to move unit with parking brake engaged; equipment damage may occur.

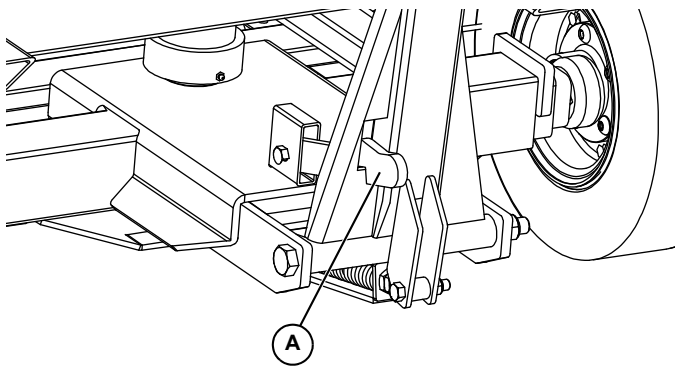

003955b

**Figure 2-7. Parking Brake Engaged**

## Engine Block Heater

See [Figure 2-1](#). The unit is equipped with a engine block heater to improve efficiency in extreme temperatures. The engine block heater warms the battery blanket and oil pan before starting, to improve starting and operation.

## Burner

The burner runs on diesel fuel drawn from the fuel tank. Unused fuel is returned to the fuel tank.

The burner reset button is located in the upper-center of the burner cover. Press the burner reset button:

- If the burner control box indicates a fault.
- As part of annual maintenance.

For more information, see the supplied OEM manual.

## Rooftop Beacons

The unit is equipped with three rooftop beacons to visually indicate unit operating status.

- **Rotating amber beacon:** Active when engine is running.
- **Flashing amber beacon:** Active when unit is at operating temperature.
- **Flashing blue beacon:** Active when fuel level is low.

## Carbon Monoxide Alarms

Because this heater produces carbon monoxide (CO) from both the engine exhaust and the burner exhaust, Generac recommends that CO detection alarms be installed in structures in close proximity to the machine during operation. CO alarms can provide an extra measure of protection against this poisonous gas that you cannot see or smell. Install battery-operated CO detection alarms or plug-in CO detection alarms with battery backup, according to the manufacturer's instructions. Any alarms should be certified to the latest safety standards.

## Section 3: Operation

### Theory of Operation

The heat cart operates in a manner similar to a forced-air heating system in many homes. After the unit is powered up, an outlet air sensor will tell the thermostat if the outlet temperature is below the preset level. If it is, the thermostat sends a low-voltage electrical signal to a relay in the burner, which signals a valve to open and draw diesel fuel into the burners and for the burner blower to turn on.

The electronic ignition in the burner lights the vaporized fuel inside the combustion chamber. This creates heat in the heat exchanger; a stainless steel box that houses exchanger tubes that are surrounded by the combustion gases from the burning diesel fuel.

The outlet air blower, which is located between the heat exchanger and the cold air intake, pulls cold air from the door duct and sends it into the heat exchanger tubes. The cold air will circulate around the heat exchanger tubes, pulling heat from the metal until it is warmed and sent to the aircraft through the flexible ducting.

The combustion gases created by the burned fuel are vented through a flue in the roof of the heat cart. The warm air sent through the ducting and the exhaust gases from the burner and heat exchanger never meet in this system. This cycle continues and is repeated as the outlet temperature is monitored and when the outlet temperature reaches the desired setting, the thermostat will turn the burner off. The blower will continue to circulate air until the outlet temperature drops to the set point, starting the heating process again.

### Before Starting Engine

#### Pre-start Checklist



#### **WARNING**

Consult Manual. Read and understand manual completely before using product. Failure to completely understand manual and product could result in death or serious injury. (000100a)



#### **WARNING**

Hot Surfaces. When operating machine, do not touch hot surfaces. Keep machine away from combustibles during use. Hot surfaces could result in severe burns or fire. (000108)

- Remove all flammable materials and fire hazards within 5 ft (1.5 m) of the unit.

- Keep the unit a minimum of 10 ft (3 m) from structures or barricades.
- Verify the unit is not leaking fluids: check inside and outside the unit for leaking fuel, engine oil, and engine coolant.
- Verify the following are clear of debris and obstructions:
  - Engine air intake
  - Engine exhaust stack
  - Outlets and fan intakes
  - Cabinet interior
  - Burner cabinet interior
- Verify air duct is securely fastened to outlet duct assembly.
- Inspect fuel, engine oil, and engine coolant levels.
- Verify unit is properly secure and level with the parking brake engaged.
- Inspect the alternator drive belt for tension and abnormalities.
- Verify the burner cover is securely installed.
- Inspect the generator. See the generator manual.
- Verify battery cable connections are not loose or corroded.
- Inspect ducting for damage or unusual wear.
- Check burner exhaust for obstructions.
- Fuel valves open.

#### Engine Oil Level Check



Engine damage. Verify proper type and quantity of engine oil prior to starting engine. Failure to do so could result in engine damage.

(000135)

**NOTE:** Wait at least 10 minutes before proceeding if engine was running.

1. Remove oil dipstick and wipe it dry with a clean, lint free cloth.
2. Slowly insert the clean oil dipstick into the oil dipstick tube. Verify the oil dipstick is fully seated.
3. After 10 seconds, remove the oil dipstick and look at the oil level on both sides. The lower of the two readings will be the correct oil level measurement.

4. Add oil (if necessary) to adjust the level. After adding or changing the oil, run the engine for one minute before checking the oil level. Wait 10 minutes to allow the engine to cool and oil to fully drain into the oil pan.

Typical causes of inaccurate oil level readings:

- Reading the high level of the oil dipstick.
- Reading the oil dipstick before the oil fully drains into the oil pan.
- Inserting and removing the oil dipstick too quickly.
- Not fully seating oil dipstick in the oil dipstick tube.

## Engine Coolant Check



**WARNING**

Risk of burns. Do not open coolant system until engine has completely cooled. Doing so could result in serious injury.

(000154)

Inspect the coolant sub-tank to check the coolant level. Check the coolant level when the engine is cold, as coolant flows to the sub-tank when the radiator is still hot, which provides an inaccurate reading. Replace the coolant according to the [Maintenance Schedule](#), or if it is contaminated or dirty. See [Adding Coolant](#).

## Ducting Guidelines

**WARNING**

Burn hazard. Do not remove ducting until all air pressure has been emptied from hose duct. Failure to do so could result in severe injury.

(000288)

- Place ducting in desired configuration before operating the unit.
- Tightly secure ducting ends to the unit and aircraft.
- Avoid sharp bends or 90° turns in the ducting.
- Verify that ducting is not in a high traffic area, and will not impede workers or other machinery. Care should be taken to prohibit the need to step or climb over ducting.
- **DO NOT** place ducting over or near combustible materials.
- **DO NOT** place ducting over or near surfaces that may damage it or reduce performance, such as water, sharp rocks or glass, electrical wiring, and piping.
- **DO NOT** place or drape anything over ducting, such as covers, insulation, blankets or cloth, or electrical wires.

## Engine and Heater Startup



**WARNING**

Hot Surfaces. When operating machine, do not touch hot surfaces. Keep machine away from combustibles during use. Hot surfaces could result in severe burns or fire.

(000108)

**WARNING**

Crushing hazard. Verify parking brake is properly secured and unit is on level ground. An unsecured unit could suddenly roll or move, and could result in death, serious injury, or equipment damage. (000352)

**WARNING**

Equipment damage. Do not attempt to start or operate a unit in need of repair or scheduled maintenance. Doing so could result in serious injury, death, or equipment failure or damage.

(000291)

**CAUTION**

Equipment or property damage. Do not block air intake or restrict proper air flow. Doing so could result in unsafe operation or damage to unit.

(000229)

Heater and fan behavior are driven by user-defined benchmarks. The blower fan starts when the main circuit breaker switch is ON, the controller is switched ON, and the START button is pressed. The thermostats operate in accordance with the temperature selection switch.

Most components mentioned in this section are identified in [Figure 2-3](#) and [Figure 2-4](#).

**NOTE:** Do not use starting aids, such as gasoline. Doing so will damage the engine.

1. Verify the emergency stop buttons are disengaged. For more information, see [Emergency Stop](#).
2. Raise tow bar to engage parking brake. For more information, see [Parking Brake Use](#).
3. Read owner's manual. Follow the pre-start checklist. For more information, see [Pre-start Checklist](#).
4. Turn battery disconnect switch to ON.
5. Turn controller power switch to ON. Wait for home screen to be displayed.



- See [Figure 3-1](#). Press start button (A).

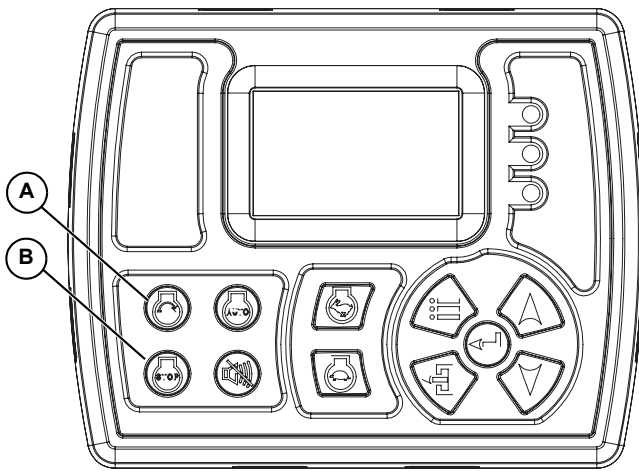

**Figure 3-1. Controller Start and Stop**

- Wait for unit to start.
- Install ducting to aircraft. Do not allow sharp bends or twists in ducting.

**IMPORTANT NOTE: A bent or twisted air duct will cause loss of air pressure and temperature.**

- Turn main circuit breaker switch to ON.
- Press the FAN START button.
- Set temperature using the temperature select switch.

When operating temperature is reached, the small amber beacon (on unit rooftop) begins flashing.

## Engine and Heater Shutdown

### **WARNING**

Personal injury. Press the emergency stop button to stop the engine immediately in case of an emergency. Failure to do so could result in death or serious injury.

(000298a)

### **CAUTION**

Equipment damage. Shut down the heater before turning off the generator. Failure to do so could result in equipment damage.

(000295)

Most components mentioned in this section are identified in [Figure 2-3](#) and [Figure 2-4](#).

- Press the STOP button. Burner shuts down and blower continues running to cool the heat exchanger. STOP button flashes until heat exchanger has cooled.
- Wait for STOP button to stop flashing, approximately 60 seconds.
- See [Figure 3-1](#). Press stop button (B).

- Turn main circuit breaker switch to OFF.

**IMPORTANT NOTE: Do not detach ducting until all static air pressure has been emptied from hose duct.**

- Press STOP button on controller.
- Rotate main battery disconnect to OFF.
- Disconnect ducting from aircraft and return it to storage area.

## Emergency Stop

### **CAUTION**

Equipment Damage. The emergency stop switch is not to be used to power down the unit under normal operating circumstances. Doing so will result in equipment damage.

(000246)

See [Figure 3-2](#). The unit is equipped with two emergency stop (E-stop) switches. One is on unit exterior (A) and one is inside the unit—behind door (B), on the control panel.

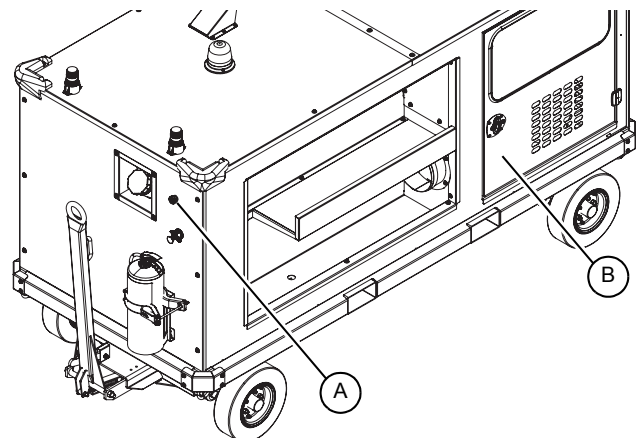

**Figure 3-2. E-Stop Switch Locations**

When engaged, the E-stop immediately shuts off the burner, fan motor, and engine. E-stop remains engaged until manually disengaged.

Operate E-stop as follows:

- To engage, push button
- To disengage, twist button until it pops out.

## Thermostats

The unit is equipped with three thermostats, located behind the thermostat access panel. They govern the temperatures associated with the LOW, MEDIUM, and HIGH settings of the temperature select switch.

Thermostat settings are adjustable, as described in this section. Record adjusted settings for future reference. See [Table 3-1](#) for factory settings.

### Overview

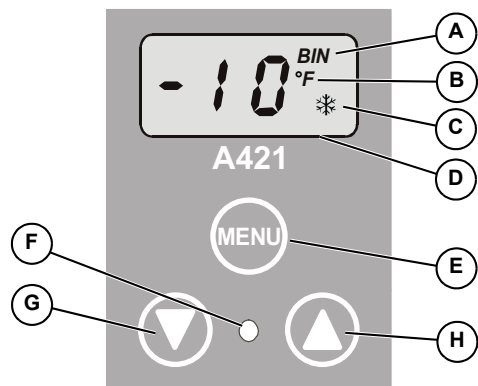

004794

Figure 3-3. Thermostat

A	Temperature offset indicator
B	Temperature units indicator
C	Operating mode indicator
D	Liquid Crystal Display (LCD)
E	MENU button
F	Output relay status indicator LED
G	Down arrow button
H	Up arrow button

### Changing Temperature Units

The thermostat is factory set to display temperature in Fahrenheit (°F). Press the up and down buttons simultaneously to convert to Celsius (°C).

### Viewing and Adjusting Temperature Set Point

1. Press MENU and the LCD displays OFF. This is the first parameter code screen displayed in the basic menu.
2. Press either UP or DOWN arrow keys until the desired parameter is displayed.
3. Press MENU to display the current value for the code.

4. Press either UP or DOWN to select the desired temperature value.
5. Press MENU to save the displayed value.
6. Repeat for the other thermostats.

### Thermostat Control

1. Press the MENU button and the LCD displays OFF.
2. Press the UP or DOWN arrow keys to reach desired function.
3. Press the MENU button to display current value of function.
4. Press the UP or DOWN arrow keys to select the desired value.
5. Press the MENU button to save. The display will return to the sensor temperature.

**NOTE:** If the MENU button is not pressed after changing the setpoint value, the new value will not be saved.

See [Table 3-1](#) for all thermostat functions.

Table 3-1. Function Ranges and Settings

Function	Range	Factory Setting
SP = Setpoint	-40–212 °F (-40–100 °C)	OFF Low: 110 Medium: 130 High: 150  ON Low: 100 Medium: 120 High: 140
DIF = Differential	1 to 30 °F or °C	10
ASd = Anti-Short Cycle Delay	0 to 12 minutes	0
SF = Sensor Failure Operation	0 = output de-energized 1 = output energized	0



## Fire Suppression System

For operation and technical data, see the OEM manuals supplied in packet.

**IMPORTANT NOTE: Servicing of the fire suppression system MUST be done by the fire suppression system manufacturer.**

### Automatic Activation

The fire suppression system will automatically activate at 356 °F (180 °C).

### Manual Activation

See [Figure 3-4](#). To manually activate the fire suppression system:

1. Pull pin (A).

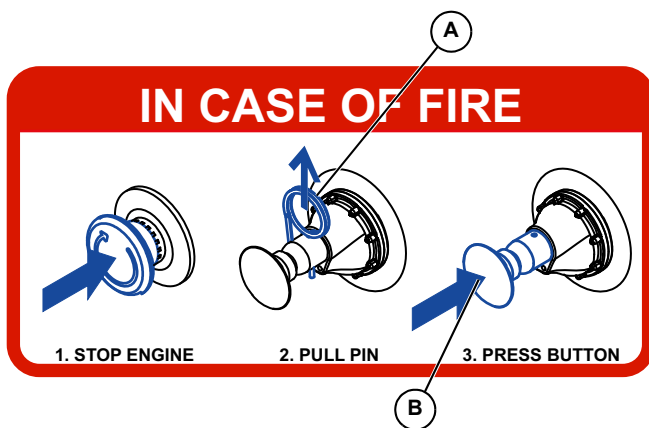

**Figure 3-4. Pin and Switch**

2. Press the electric manual actuator switch (B).

### Recharging System

**IMPORTANT NOTE: After use, the fire suppression system MUST be recharged by an ANSUL dealer.**

**This page intentionally left blank.**

## Section 4: Maintenance

### Maintenance

Regular maintenance will improve performance and extend engine/equipment life. Generac Mobile Products, LLC. recommends that all maintenance work be performed by a Generac Mobile Products Authorized Service Dealer (GMP ASD). Regular maintenance, replacement, or repair of the emissions control devices and systems may be performed by any repair shop or person of the owner's choosing. To obtain emissions control warranty service free of charge, the work must be performed by a GMP ASD. See the emissions warranty.

### Maintenance Tasks

Daily checks must be performed when the unit is operated continuously for extended periods of time. Daily checks and routine monthly checks can be performed by an authorized operator.

**NOTE:** Normal maintenance, service, and replacement of parts are the responsibility of the owner and are not considered defects in materials or workmanship within the terms of the warranty. It is strongly recommended that equipment be periodically checked by a GMP ASD.

### Daily Walk Around Inspection

Inspect for conditions that could hinder performance or safety, such as (but not limited to) oil, coolant, and fuel leakage, blocked vents, loose or missing hardware, and improper electrical connections. Inspect for foreign matter blocking the vents and on top of unit. Perform any necessary maintenance tasks.

- Inspect outer enclosure for significant damage beyond scuffs and small nicks.
- Inspect for electrical wire abrasion.
- Inspect the fan belt for cracking, fraying, and stretching. Verify the belt is properly seated in the pulley grooves.
- Check fluid levels.
- Check electrical connectors, battery, and ground points. Look for loose or missing hardware.
- Inspect all flexible rubber hoses for deterioration.
- Verify hoses are not crushed, bent, or twisted.
- Verify there are no cracks or corrosion.
- Inspect tires for unusual wear.
- Inspect ducting for damage or unusual wear.

### Draining and Refilling the Oil



#### WARNING

Risk of burns. Allow engine to cool before draining oil or coolant. Failure to do so could result in death or serious injury.

(000139)

#### WARNING

Skin irritation. Avoid prolonged or repeated contact with used motor oil. Used motor oil has been shown to cause skin cancer in laboratory animals. Thoroughly wash exposed areas with soap and water.

(000210)

1. Place container under drain port hose, located beneath the unit.
2. Open drain valve. Drain oil.
3. Close drain valve once draining is complete.
4. See engine manual for oil filter information.
5. Remove filler cap on rocker arm cover or on the side of the engine.
6. Fill oil pan to specified level.
7. Replace filler cap.

**NOTE:** Do not over-tighten filler cap. Over-tightening may damage filler cap.

8. Start and run engine for five minutes. Verify there are no leaks.
9. Stop the engine and let cool for approximately 10 minutes. Verify oil level is correct. (See [Engine Oil Level Check](#).) Repeat steps 7–9 until oil is properly filled.

**IMPORTANT NOTE:** Do not overfill oil pan. Overfilling may result in white exhaust smoke, sudden over engine speed, or engine damage.

**NOTE:** Dispose of waste oil in accordance with local, state, or national codes or regulations.

## Adding Coolant



### **⚠ DANGER**

Risk of poisoning. Do not use mouth to siphon coolant. Doing so will result in death or serious injury.

(000149)



### **⚠ WARNING**

Risk of burns. Contents under pressure. Do not remove the radiator pressure cap while engine is hot. Doing so could result in death or serious injury.

(000322a)



### **⚠ WARNING**

Risk of burns. Do not open coolant system until engine has completely cooled. Doing so could result in serious injury.

(000154)

### **⚠ CAUTION**

Risk of overheating. Do not use any chromate base rust inhibitor with propylene glycol base antifreeze, boosters, or additives. Doing so will cause overheating and possible equipment damage.

(000165a)

Coolant must be changed every year or at 1000 hours of operation. Check coolant level and degree of fouling according to the steps below. Correct coolant level is approximately 0.39 in (10 mm) below the radiator core top.

**NOTE:** Wear the proper PPE when handling Long Life Coolant.

1. Verify engine is stopped and cooled.
2. Verify the drain plug is closed.
3. Remove radiator cap.
4. Fill radiator slowly with coolant until it reaches the lip of the filler port.
5. Replace radiator cap.
6. Remove cap from the sub-tank.
7. Fill the sub-tank with coolant until it reaches the FULL mark.
8. Replace sub-tank cap.
9. Operate engine approximately five minutes at a low idle speed to purge the air in the coolant system.

**NOTE:** Coolant level will drop.

10. Stop the engine and, once cooled, replenish with coolant until the sub-tank reaches the FULL mark.

## Fire Suppression System

**IMPORTANT NOTE:** After use, the fire suppression system **MUST** be recharged by an ANSUL dealer.

## Maintenance Schedule

The following is the manufacturer's recommended maintenance schedule. The maintenance items need to be performed more frequently if the heater is used in severe applications (such as very high or very low ambient conditions or extremely dirty/dusty environments). Use the heater hour meter or calendar time, whichever occurs first, from the previous maintenance interval to determine the next required maintenance interval. Note that some checks are based on hours of operation.

Follow all applicable safety alerts found in this manual or engine service manual before performing any maintenance checks or service.

This maintenance schedule reflects the minimum tasks needed to verify the heater remains operational. Some of the tasks can be performed by an authorized operator, and others must be performed by a GMP ASD.

**NOTE:** An authorized operator is one who has been trained by a GMP ASD in proper operation and inspection of this unit.

## Maintenance Schedule

<b>Daily</b>	<ul style="list-style-type: none"> <li>• Inspect fuel level.</li> <li>• Inspect engine oil level.</li> <li>• Inspect coolant.</li> <li>• Inspect governor lever.</li> <li>• Drain water separator.</li> <li>• Inspect radiator and engine cooling fan.</li> <li>• Inspect generator intake and exhaust air screens for debris.</li> </ul>
<b>50 Hour Break-In</b>	<ul style="list-style-type: none"> <li>• Replace engine oil and engine oil filter. <sup>2</sup></li> <li>• Inspect and adjust cooling fan V-belt.</li> </ul>
<b>Every 50 Hours</b>	<ul style="list-style-type: none"> <li>• Drain water separator.</li> <li>• Inspect wheel bearings.</li> </ul>
<b>Every 250 Hours</b>	<ul style="list-style-type: none"> <li>• Replace engine oil and engine oil filter. <sup>2</sup></li> <li>• Inspect and adjust cooling fan V-belt.</li> <li>• Clean air cleaner and dust pan. (Clean more frequently under dusty conditions.)</li> <li>• Inspect and clean radiator fins.</li> <li>• Inspect and clean battery.</li> </ul>
<b>Every 500 Hours</b>	<ul style="list-style-type: none"> <li>• Clean water separator.</li> <li>• Replace fuel filter.</li> <li>• Replace air cleaner.</li> <li>• Replace burner fuel filter.</li> </ul>
<b>Every 750 Hours</b>	<ul style="list-style-type: none"> <li>• Remove fan belt and check for wear.</li> <li>• Inspect pulleys and bearings. Rotate and feel for hard turning or unusual sounds.</li> </ul>
<b>Every 1000 Hours<sup>1</sup></b>	<ul style="list-style-type: none"> <li>• Test coolant, replace if necessary. See engine manual.</li> <li>• Adjust intake/exhaust valve clearance. <sup>1</sup></li> <li>• Inspect generator bearings. See generator manual.</li> </ul>
<b>Every 1500 Hours</b>	<ul style="list-style-type: none"> <li>• Inspect, test, and clean fuel injectors.</li> <li>• Inspect crankcase breather system.</li> <li>• Inspect and reset burner. See burner manual.</li> </ul>
<b>Every 2000 Hours<sup>1</sup></b>	<ul style="list-style-type: none"> <li>• Flush coolant path.</li> <li>• Replace fuel and coolant hoses.</li> <li>• Lap intake/exhaust valve seats. <sup>1</sup></li> <li>• Check and adjust fuel injection timing.</li> <li>• Inspect and adjust EPA emission related parts.</li> <li>• Inspect DC no load excitation voltage in generator.</li> <li>• Replace burner nozzle</li> </ul>
<p><sup>1</sup> Contact a GMP ASD for completion of these maintenance items.</p> <p><sup>2</sup> Actual oil life and change intervals should be determined through oil sampling and analysis in extreme conditions.</p> <p><b>NOTE:</b> For more information, see the diesel engine OEM manual.</p>	

## Battery Inspection



### ⚠ DANGER

Electrocution. Do not wear jewelry while working on this equipment. Doing so will result in death or serious injury.

(000188)



### ⚠ WARNING

Explosion. Batteries emit explosive gases while charging. Keep fire and spark away. Wear protective gear when working with batteries. Failure to do so could result in death or serious injury.

(000137a)



### ⚠ WARNING

Electrical shock. Disconnect battery ground terminal before working on battery or battery wires. Failure to do so could result in death or serious injury.

(000164)



### ⚠ WARNING

Explosion. Do not dispose of batteries in a fire. Batteries are explosive. Electrolyte solution can cause burns and blindness. If electrolyte contacts skin or eyes, flush with water and seek immediate medical attention.

(000162)



### ⚠ WARNING

Risk of burn. Do not open or mutilate batteries. Batteries contain electrolyte solution which can cause burns and blindness. If electrolyte contacts skin or eyes, flush with water and seek immediate medical attention.

(000163a)

### ⚠ WARNING

Accidental start-up. Disconnect negative battery terminal before servicing to prevent accidental engine rotation. Failure to do so could result in death or serious injury.

(000148a)

### ⚠ WARNING

Environmental Hazard. Always recycle batteries at an official recycling center in accordance with all local laws and regulations. Failure to do so could result in environmental damage, death or serious injury.

(000228)

Always recycle batteries in accordance with local laws and regulations. Contact your local solid waste collection site or recycling facility to obtain information on local recycling processes. For more information on battery recycling, visit the Battery Council International website at: <http://batteryCouncil.org>

**NOTE:** Turn off the battery switch and disconnect the black negative cable before inspecting or working on the electrical system. Always disconnect the negative cable first.

An authorized operator should inspect the engine battery monthly. At this time, the battery fluid level should be checked using a load tester, and distilled water added if needed. Battery cables and connections should also be inspected for cleanliness and corrosion.

A GMP ASD should inspect the battery system once every six months. The battery condition and state of charge should be checked using a load test battery at this time. The battery should be recharged or replaced as required.

Battery service is to be performed or supervised by personnel knowledgeable of batteries and the required precautions. Keep unauthorized personnel away.

Observe the following precautions when working on batteries:

- Remove watches, rings, or other metal objects.
- Use tools with insulated handles.
- Wear rubber gloves and boots.
- Do not lay tools or metal parts on top of battery.
- Disconnect charging source prior to connecting or disconnecting battery terminals.

**NOTE:** Spilled electrolyte is to be washed down with an acid neutralizing agent. A common practice is to use a solution of 1 lb (454 g) bicarbonate of soda (baking soda) to 1 gal (3.8 L) of water. The bicarbonate of soda solution is to be added until the evidence of reaction (foaming) has ceased. The resulting liquid is to be flushed with water.

**NOTE:** Discharge static electricity by first touching a grounded metal surface before touching the battery.

## Battery Installation and Replacement



### ⚠ WARNING

Explosion hazard. Never add acid to a battery. Add distilled water only. Failure to do so could result in death, serious injury, or equipment damage.

(000316)

The battery must be replaced with one of equivalent size, voltage, and CCA (cold crank amp capacity), when required. Minimum CCA for this unit is 720. Contact a GMP ASD for correct battery size. A new battery must be filled with the proper electrolyte and be fully charged before installing.

Battery cables are connected to the unit at the factory. Connect cables to battery posts as follows.



### CAUTION

Equipment damage. Do not make battery connections in reverse. Doing so will result in equipment damage.

(000167a)

1. Connect red battery cable from starter contactor to positive (POS or +) battery post.
2. Connect black battery cable to negative (NEG or -) battery post.
3. Refer to [Engine and Heater Startup](#).

## Other Maintenance Checks

The following inspections should be performed by an authorized service technician, or a properly trained authorized operator. These maintenance items require a high level of experience and skill to evaluate and correct.

- Inspect engine accessory drive belts.
- Inspect hoses and connections.
- Inspect fuel supply system.
- Inspect exhaust system.

## Storing the Unit

### Short Term Storage

When the machine will not be used for 3–6 months, follow the guidelines below to properly store the machine:

- Perform all necessary maintenance or repairs based on the [Maintenance Schedule](#). If necessary maintenance is upcoming, perform the maintenance action before storing.
- Fill the fuel tank to FULL.
- Fill coolant to FULL. Do not drain.
- Remove all dirt and debris from inside and outside the enclosure.
- Lock the machine to prevent any unauthorized operation.
- Store in a safe location — do not position near or on top of any combustible materials; observe any local, state, or national codes or regulations. Store in a low moisture, low dust area.
- Disconnect the negative cable from the battery.

### Long Term Storage

When the machine will not be used for over six months, follow the guidelines below to properly store the machine:

1. Fill fuel tank with stabilized fuel and operate the burner for at least fifteen minutes to ensure

circulation through entire fuel system. Use a brand of fuel stabilizer compatible with diesel fuel.

2. Allow heater to cool completely. Cover the burner exhaust and air outlet with plastic wrap or other waterproof material.

**NOTE:** Covering burner exhaust and air outlet prevents moisture build-up inside the heater and prevents blockages caused by animal nests.

3. Cover the blower intake ducting; on the bottom of the unit and the blower intake itself with waterproof covering.
4. Remove and store any ducting away from direct sunlight.
5. Remove the battery and store in a cool, dry place. Connect the battery to a trickle charger once every 30 days to maintain a full charge.
6. Close and lock all doors.
7. Cover the engine exhaust outlet, engine air intake, and radiator outlet with waterproof covering.
8. If applicable, protect the trailer tires from direct sun light.

## Return to Service

### WARNING

Equipment damage. Do not attempt to start or operate a unit in need of repair or scheduled maintenance. Doing so could result in serious injury, death, or equipment failure or damage.

(000291)

1. Remove covers from engine exhaust outlet, engine air intake, and radiator outlet.
2. Remove covers from blower intake ducting—on bottom of unit and on the blower intake.
3. If applicable, remove protection from trailer tires.
4. Remove cover from burner exhaust and air outlet.
5. Install battery.
6. Verify maintenance is up-to-date. See [Maintenance Schedule](#).
7. Check all fluids for signs of fouling or degradation.
8. Inspect unit in accordance with the [Daily Walk Around Inspection](#).
9. Carefully follow the [Pre-start Checklist](#).
10. Run engine for more than 10 minutes.

**NOTE:** Do not start or operate a machine in need of repair or maintenance. Perform all maintenance tasks and repairs before starting. Contact a GMP ASD if there is any doubt as to the machine's usability.

**This page intentionally left blank.**



# Section 5: Troubleshooting

## General Troubleshooting Guide

Problem	Cause	Solution
Engine will not crank	Low battery output voltage or discharged battery.	Charge or replace batteries. See <a href="#">Battery Installation and Replacement</a> .
	Loose or corroded connections.	Clean and tighten connections. Replace as necessary.
	Faulty start circuit relay.	Contact a GMP ASD.
	Blown fuse.	Replace fuse.
	Faulty main switch or start safety switch.	Repair switch as required.
	Faulty starter solenoid.	Replace solenoid.
	Faulty starter.	Replace starter.
Starter cranks slowly	Engine seized.	Contact a GMP ASD.
	Low battery output voltage or discharged battery.	Charge or replace battery. See <a href="#">Battery Installation and Replacement</a> .
	Excessive crankcase oil viscosity.	Drain crankcase oil and replace with correct viscosity oil. See <a href="#">Draining and Refilling the Oil</a> .
	Loose or corroded connections.	Clean and tighten connections. Replace as necessary.
Engine misfiring or runs irregularly	Faulty starter switch or starter motor.	Contact a GMP ASD.
	Poor fuel quality; incorrect/dirty fuel.	Test fuel, drain water from fuel bowl. Replace with proper fuel.
	Restricted fuel filter.	Replace fuel filter element.
	Water, dirt, or air in fuel system.	Drain, flush, fill, and purge fuel system. See the engine manual.
	Low coolant temperature.	Remove and check thermostat.
	Dirty or faulty fuel injectors.	Contact a GMP ASD.
	Electronic fuel system problem.	
Electronic control system or basic engine problem.		
Fuel return valve or fuel supply valve OFF.	Set valve to ON.	

Problem	Cause	Solution
Hard to start or will not start	Incorrect starting procedure.	Review starting procedure. See <a href="#">Before Starting Engine</a> and <a href="#">Engine and Heater Startup</a> .
	Restricted exhaust.	Check and correct exhaust restriction.
	No fuel. Fuel valves closed, not allowing fuel to return or supply.	Check fuel tank and replenish. Open fuel valves.
	Air in fuel line.	Purge fuel lines. See engine manual.
	Poor fuel quality.	Drain fuel and replace with proper grade and quality of fuel for operating condition.
	Water, dirt, or air in fuel system.	Drain, flush, fill, and purge fuel system. See the engine manual.
	Fuel filter restricted or full of water.	Replace fuel filter or drain water from fuel filter.
	Dirty or faulty fuel injectors.	Contact a GMP ASD.
	Electronic fuel system problem.	
	Cold weather.	Use cold weather starting aids (see engine manual).
	Excessive crankcase oil viscosity.	Drain crankcase oil and replace with correct viscosity oil. See <a href="#">Draining and Refilling the Oil</a> .
	Lack of engine power	Electronic control system problem or basic engine problem.
Compressed air leakage from intake/ exhaust valves.		
Restricted air intake.		Service air cleaner.
Restricted exhaust.		Check and correct exhaust restriction.
Poor fuel quality.		Drain fuel and replace with proper grade and quality of fuel for operating condition.
Restricted fuel filter.		Replace fuel filter elements.
Overloaded engine.		Reduce engine load.
Incorrect crankcase oil.		Drain crankcase oil and replace with correct viscosity oil. See <a href="#">Draining and Refilling the Oil</a> .
Low coolant temperature.		Remove and check thermostat.
Incorrect valve clearance.		Adjust valve clearance or contact a GMP ASD.
Dirty or faulty fuel injectors.		Contact a GMP ASD.
Air leak in engine intake or exhaust manifold.		Check intake and exhaust manifold gaskets and manifolds; repair as required or contact a GMP ASD.
Engine is in derate due to DTC.	Contact a GMP ASD.	
Electronic control system or basic engine problem.		

Problem	Cause	Solution
Excessive fuel consumption	Engine overloaded.	Reduce engine load.
	Restricted or dirty air cleaner.	Replace air cleaner element as required.
	Insufficient compression.	Determine cause of low compression and repair as required.
	Leaks in fuel supply system.	Locate source of leak and repair as required.
	Poor fuel quality or incorrect type of fuel.	Drain fuel and replace with proper grade and quality of fuel for operating condition.
	Incorrect valve clearance.	Adjust valve clearance or contact a GMP ASD.
	Dirty or faulty fuel injectors.	Contact a GMP ASD.
	Electronic fuel system problem.	
	Electronic control system or basic engine problem.	
	Low engine temperature.	Remove and check thermostat.
Fuel in oil	Restricted fuel return line.	Check and fix fuel return lines. Check return fuel valve position.
	Insufficient engine load.	Increase engine load.
	Leaking fuel injectors.	Contact a GMP ASD.
Low-pressure fuel system — fuel pressure low	Restricted fuel filter.	Replace fuel filter.
	Restricted fuel line.	Locate restriction, repair as required. Check return fuel valve position.
	Faulty transfer pump.	Contact a GMP ASD.
	Faulty high-pressure fuel pump.	Remove fuel pump, repair/replace pump as required.

Problem	Cause	Solution
Abnormal engine noise	Worn main or connecting rod bearings.	Contact a GMP ASD.
	Excessive crankshaft end play.	
	Loose main bearing caps.	
	Worn connecting rod bushings and piston pins.	
	Scored pistons.	
	Worn timing gears or excess backlash.	
	Excessive valve clearance.	
	Worn camshaft lobes.	
	Worn rocker arm shaft(s); worn or loose rocker arms.	
	Worn valve guides.	
	Damaged valve retainers.	
	Bent pushrods or connecting rods.	
	Broken valve springs.	
	Worn or loose flywheel.	
	Excessive piston to liner clearance.	
Excessive thrust bearing clearance.		
Excessive oil viscosity.		
Engine emits white smoke	Insufficient engine compression.	Determine cause of low compression and repair as required, or contact a GMP ASD.
	Faulty thermostat(s) (does not close).	Test thermostats; replace thermostat(s) as required.
	Coolant entering combustion chamber (failed cylinder head gasket or cracked cylinder head).	Repair or replace as required, or contact a GMP ASD.
	Electronic control system or basic engine problem.	Contact a GMP ASD.
	Poor fuel quality or incorrect type of fuel.	Drain fuel and replace with proper grade and quality of fuel for operating condition.
	Low engine temperature.	Warm up engine to normal operating temperature.
	Faulty fuel injectors.	Contact a GMP ASD.
Excessive oil.	Drain oil to proper level. See <a href="#">Draining and Refilling the Oil</a> .	

Problem	Cause	Solution
Engine emits black, gray, or blue smoke	Restricted or dirty air cleaner.	Replace air cleaner element as required.
	Incorrect type of fuel.	Use proper fuel.
	Engine burning oil.	Contact a GMP ASD.
	Electronic control system or basic engine problem.	
	Cracked or damaged exhaust filter.	
	Dirty fuel injectors.	
	Engine overloaded.	
	Excessive intake or exhaust valve clearance.	
Engine overheats	Restricted or dirty air cleaner.	Replace air cleaner element as required.
	Insufficient coolant in cooling system.	Fill cooling system to proper level. Check radiator and hoses for loose connections or leaks. See <a href="#">Adding Coolant</a> .
	Insufficient engine oil.	Check oil level. Add oil as required. See <a href="#">Draining and Refilling the Oil</a> .
	Dirty radiator core.	Clean cooling system as required.
	Cooling system needs flushing.	Flush coolant system.
	Engine overloaded.	Reduce engine load.
	Loose or faulty fan belt.	Check non-automatic belt tensioner and belts. Replace as required.
	Faulty or incorrect type of thermostats.	Test thermostat opening temperature, replace thermostats as required.
	Faulty radiator cap.	Replace radiator cap as required.
	Faulty sender.	Check coolant temperature with thermometer and replace if necessary.
	Incorrect grade of fuel.	Drain fuel and replace with proper grade and quality of fuel for operating condition.
	Damaged or leaking cylinder head gasket. Faulty coolant pump.	Contact a GMP ASD.
Coolant temperature below normal	Faulty thermostat(s).	Test and replace thermostat(s) as required.
	Faulty temperature sender.	Check gauge, sender, and connections.
Coolant in crankcase	Faulty cylinder head gasket.	Contact a GMP ASD.
	Cracked cylinder head or block.	
	Leaking cylinder liner seals.	
	Pitted cylinder liners.	
	Faulty coolant pump seal; weep hole plugged; coolant leaking through bearing.	

Problem	Cause	Solution
Excessive oil consumption	Insufficient crankcase oil viscosity.	Drain crankcase and refill with correct viscosity oil. See <a href="#">Draining and Refilling the Oil</a> .
	Excessive crankcase oil.	Drain oil until oil level is correct. See <a href="#">Draining and Refilling the Oil</a> .
	External oil leak(s).	Determine source of oil leak(s) and repair as required.
	Restricted crankcase vent tube.	Clean vent tube, verify that crankcase oil level is correct.
	Excessive oil pressure.	Contact a GMP ASD.
	Worn, broken, or unseated oil control rings.	
	Scored cylinder liners or pistons.	
	Worn valve guides or stems.	
	Faulty front and/or rear crankshaft oil seal.	
	Piston ring gaps not staggered.	
	Insufficient piston ring tension.	
	Piston rings sticking in ring grooves.	
Piston ring grooves excessively worn.		
Batteries will not charge	Loose or corroded connections.	Clean and tighten connections.
	Sulfated or worn-out batteries.	Replace batteries. See <a href="#">Battery Installation and Replacement</a> .
	Stretched belt or defective belt tensioner.	Adjust belt tension or replace belts.
	Faulty alternator.	Verify alternator output; replace if faulty.
Entire electrical system does not function	Faulty battery connection.	Clean and tighten connections.
	Sulfated or worn-out batteries.	Replace batteries. See <a href="#">Battery Installation and Replacement</a> .
	Blown fuse.	Replace fuse.
Abnormal generator noise	Faulty bearing(s).	Replace bearing(s).
	Loose or misaligned coupling.	Tighten, realign, or replace coupling.
Generator overheating	Overloaded generator.	Reduce load. Contact a GMP ASD.
	Clogged ventilation screens.	Clean air passages and screens.
	High temperature or altitude.	Reduce load, increase ventilation. Contact a GMP ASD.
	Insufficient air circulation.	Contact a GMP ASD.
	Unbalanced load.	

## Burner Troubleshooting

For additional questions, refer to the burner OEM manual supplied in the packet.

Problem	Cause	Solution
Burner does not start	Burner switch is OFF.	Switch burner ON.
	Burner breaker is OFF.	Switch burner breaker ON.
	Heat cart is out of fuel.	Add fuel.
	Fuel is not reaching burner.	Open fuel supply and return valves.
	Over-temperature limit has tripped.	Allow unit to cool.
Burner starts but flame does not ignite	Heat cart is out of fuel.	Add fuel.
	Burner nozzle damaged or worn.	Replace burner nozzle.
	Ignition electrodes malfunction.	Replace ignition electrodes.
	Burner primary control malfunction.	Replace burner primary control.
Burner start and flame ignites, but unit locks out	Fuel pressure setting is incorrect.	Adjust fuel pressure.
	Burner nozzle damaged or worn.	Replace burner nozzle.
	Air damper setting is incorrect.	Adjust air damper.
	Burner primary control malfunction.	Replace burner primary control.
Combustion is poor or noisy	Fresh-air supply to burner is insufficient.	Provide sufficient air supply to burner.
	Air damper set incorrectly.	Adjust air damper.
Excessive blower noise	Motor bearings malfunction.	Replace motor bearing.
	Mounting base not secure.	Tighten mounting hardware.
Motor overheating	Motor malfunction.	Replace motor.
	Voltage incorrect.	Check power supply.
Fan not working	Circuit breaker tripped.	Reset circuit breaker.
	Wiring loose or disconnected.	Check wiring; repair as needed.
Thermostat not functioning	Incorrect wiring.	Contact a GMP ASD.
	Insufficient supply voltage.	
	Incorrect sensor operation.	
	Display shows fault code.	See the thermostat manual, or contact a GMP ASD.
No heat	Burner malfunction.	See the burner manual, or contact a GMP ASD.

**This page intentionally left blank.**



## *Section 6: Installation Diagrams and Service Log*

### **Control Box Wiring Diagram (1 of 3)**

Refer to electrical diagram supplied in packet.

# Control Box Wiring Diagram (2 of 3)

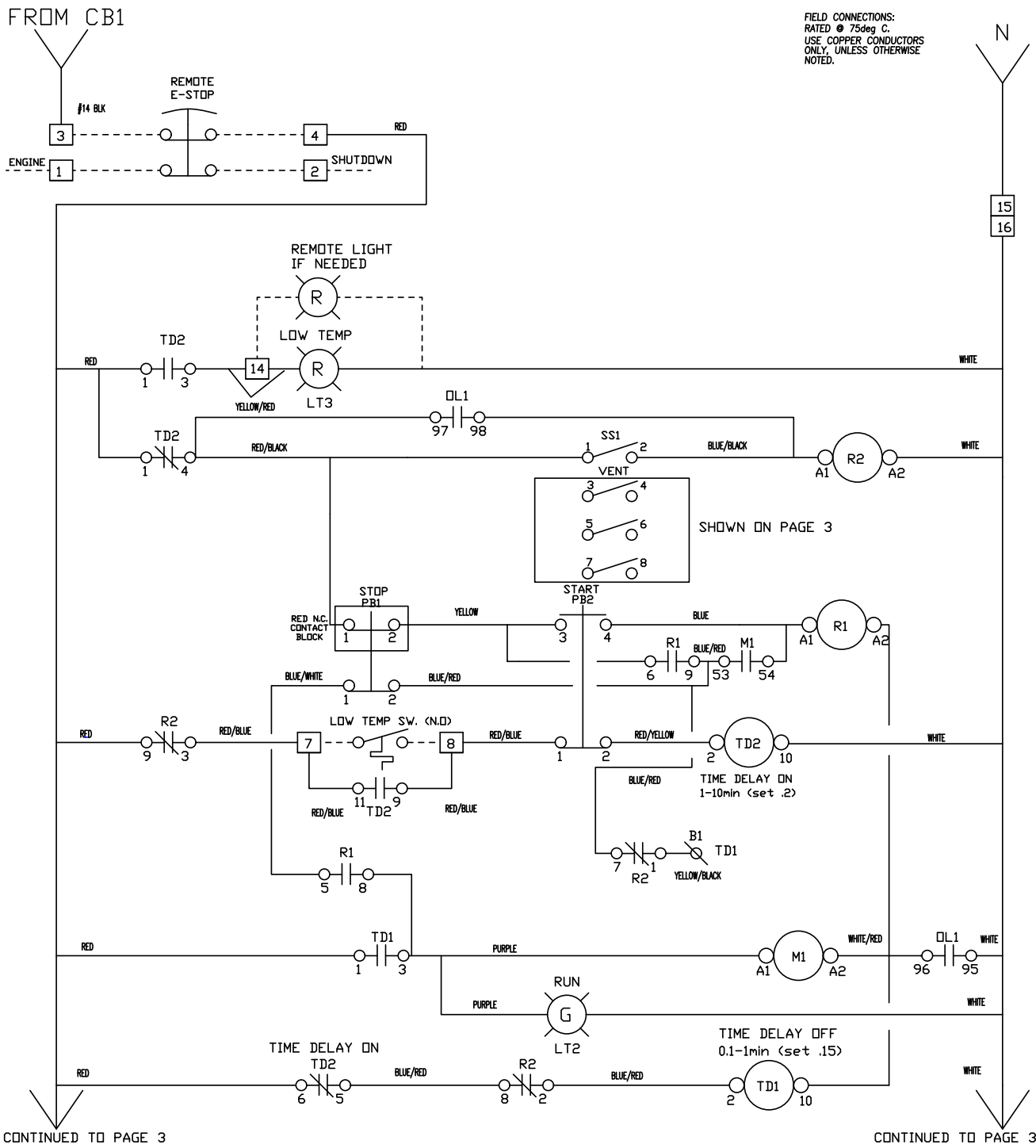

### Control Box Wiring Diagram (3 of 3)

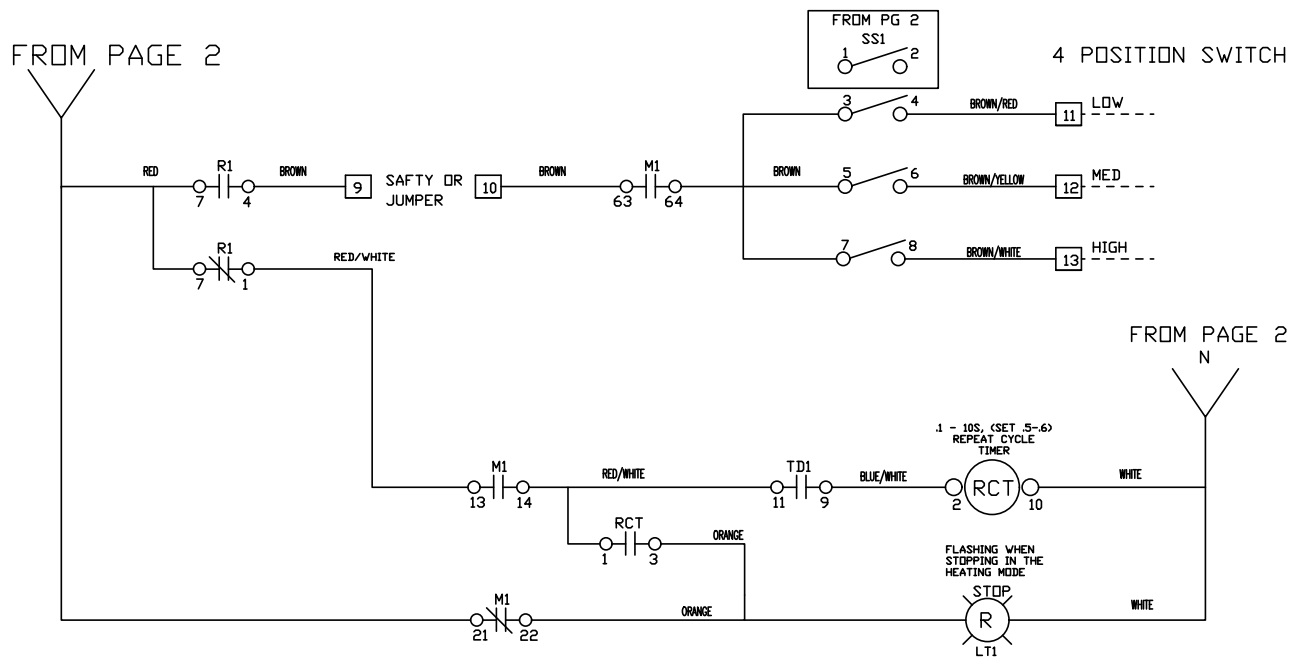

- |   |   |
|---|---|
| 1 | 2 |
|---|---|

 REMOTE E-STOP IF NEEDED FOR ENGINE
- |   |   |
|---|---|
| 3 | 4 |
|---|---|

 REMOTE E-STOP IF NEEDED FOR PANEL
- |   |   |
|---|---|
| 5 | 6 |
|---|---|

 208VAC FOR REMOTE 208X24 TRANSFORMER
- |   |   |
|---|---|
| 7 | 8 |
|---|---|

 LOW TEMP SHUT DOWN (NORMALLY OPEN, CLOSE AT 70F)
- |   |    |
|---|----|
| 9 | 10 |
|---|----|

 SAFTY OR JUMPER FOR HEATING SYSTEM
- |    |    |    |
|----|----|----|
| 11 | 12 | 13 |
|----|----|----|

 POWER FOR LOW, MED, & HIGH HEAT
- |    |
|----|
| 14 |
|----|

 REMOTE LOW TEMP LIGHT IF NEEDED
- |    |    |
|----|----|
| 15 | 16 |
|----|----|

 N USED AS NEEDED
- |       |
|-------|
| 17-20 |
|-------|

 SPARES

FIELD CONNECTIONS:  
RATED @ 75deg C.  
USE COPPER CONDUCTORS ONLY, UNLESS OTHERWISE NOTED.

**CAD DRAWING KEY**

- CB1- CIRCUIT BREAKER 1 CONTROL BREAKER
- FIELD WIRING TERMINAL
- |    |
|----|
| 00 |
|----|

 MAIN CONTROL PANEL TERMINAL BLOCK
- |    |
|----|
| 00 |
|----|

 REMOTE PANEL TERMINAL BLOCK

### Service Log

OIL GRADE: \_\_\_\_\_ BRAND: \_\_\_\_\_

COOLANT MIXTURE: \_\_\_\_\_ BRAND: \_\_\_\_\_

---

---

---

---

---

---

---

---

---

---

---

---

---

---

---

---

---

---

---

---

---

---

---

---

Date	Hours to Service	Oil Level	Coolant Level

Date	Hours to Service	Oil Level	Coolant Level

**This page intentionally left blank.**

**This page intentionally left blank.**



Part No. 1000023395 Rev. A 02/07/18  
©2017 Generac Mobile Products, LLC  
All rights reserved.  
Specifications are subject to change without notice.  
No reproduction allowed in any form without prior written  
consent from Generac Mobile Products, LLC.

**GENERAC**  
  
**MOBILE  
PRODUCTS**

Generac Mobile Products, LLC  
215 Power Drive, Berlin, WI 54923  
[GeneracMobileProducts.com](http://GeneracMobileProducts.com) | 800-926-9768 | 920-361-4442