



EveryStage™

Child Restraint System Owner's Manual

Keep instructions for future use.

Rear-facing*

1,8 to 22,6 kg
(4 to 50 lbs)

43 to 122 cm
(17 to 48 in.)

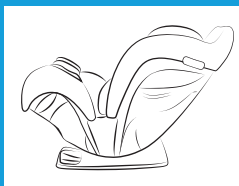

Forward-facing with Harness*

10 to 29.4 kg
(22 to 65 lbs)

71 to 124 cm
(28 to 49 in.)

At least 2 years old

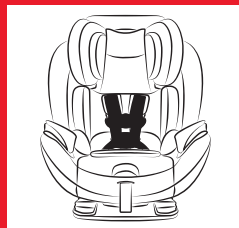

Booster*

18 to 54,4 kg
(40 to 120 lbs)

112 to 145 cm
(44 to 57 in.)

At least 4 years old



* See page 4-5 for complete requirements.

Para instrucciones en Español,
llamar al: 1-800-233-2229

⚠️ WARNING!

To reduce the risk of serious injury
or death, read this owner's manual prior
to installing and using this child restraint.

More children are killed every year as passengers in car crashes than by any other type of injury.

To reduce the risk of **SERIOUS INJURY** or **DEATH**, read this owner's manual and your vehicle owner's manual before installing and using this child restraint. Using a child restraint makes a big difference. By properly using this child restraint and following these instructions (and the instructions that accompany your vehicle), you will greatly reduce the risk of serious injury or death to your child from a crash. Do not be misled by the commonly used term "safety seat"; no restraint system can prevent all injuries in all crashes. Many properly restrained adults and children are injured in motor vehicle crashes, including relatively minor crashes. A properly used child restraint is the best way to minimize injuries to your child and to increase the chances for your child's survival in most crashes.

FEDERAL STANDARD NO. 213 - Child Restraint Systems

This child restraint conforms to all applicable Federal motor vehicle safety standards.

CANADIAN REGULATORY NOTICE (Model numbers ending in "C.")

This child restraint meets all applicable requirements of Canadian Motor Vehicle Safety Standards CMVSS 213 213.1 and 213.2.

Symbol Legend



Airbag Symbol – Alerts you to important information about airbag safety.



LATCH Symbol – Alerts you to important information about LATCH safety.



Tether Anchor Symbol – Alerts you to important information about Tether Anchor safety.



Aircraft Symbol – Alerts you to important information about aircraft safety.



Table of Contents (TOC)

Child Requirements	4
Premature Infant Use	6
Warnings	7
Safe Practices	18
For Recall Information for U.S. Customers	18
Public Notice for Canadian Customers	19
Motor Vehicle/Aircraft Usage	19,70-73
Child Restraint Features	20

Rear-facing

Using the Child Restraint Rear-Facing	26
Using the Anti-Rebound Bar (Canada Only)	27
Rear-facing Installation with Lower Anchor Connectors	28
Rear-facing Installation with Vehicle Seat Belts	33
Rear-facing Installation Checklist	37

Forward-facing with Harness

Using the Child Restraint Forward-Facing with Harness	38
Forward-facing Installation with Lower Anchor Connectors	39
Forward-facing Installation with Vehicle Seat Belts	45
Attaching the Tether	43,49
Forward-facing Installation Checklist	51

Booster Mode

Using the Child Restraint in Booster Mode	52
When to Put Your Child in a Booster Seat	53
Booster Installation Checklist	55
Converting into a Booster Seat	56

General Information

Adjusting the Headrest/Harness Position	58
Reclining the Child Restraint	58
Adjusting the Crotch Strap Position	59
Securing the Child in the Child Restraint	60
Removing the Child from the Child Restraint	62
Removing the Tether Strap	63
General Information about SensorSafe™	64
Installing Child Restraint Rear-facing in Aircraft	70
Installing Child Restraint Forward-facing in Aircraft	72
Removing the Seat Pad	74
Care and Cleaning	79
Storing Your Instructions	80
Replacement Parts / Useful Life	81
Warranty	82

CHILD REQUIREMENTS

Warning: Failure to follow these Child Requirements could result in serious injury or death.

This child restraint is designed for use by children in both **rear-facing** and **forward-facing** orientations. To use this child restraint properly, children **MUST** meet the size and age requirements below. In addition, Evenflo recommends consulting with your child's physician before allowing your child to transition from **rear-facing** to **forward-facing** use of this child restraint.

The American Academy of Pediatrics (AAP) recommends keeping children **rear-facing** until they reach the maximum height or weight for their child restraint in **rear-facing** orientation. Additionally, some states' laws require children to be **rear-facing** until age 2. Accordingly, you will see this guidance reflected in the Child Requirements below. Please review any applicable local, state or provincial laws related to child passenger safety before installing and using this child restraint.

Rear-facing

- 1,8 to 22.6 kg (4 to 50 lbs)
- 43 to 122 cm (17 to 48 in.) and top of child's head is at least 2.5 cm (1 in.) or more below the bottom of the adjustment handle

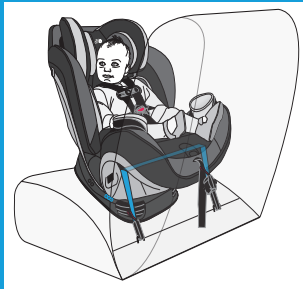

IMPORTANT:

Once your child **exceeds** any of the size requirements above, they **MUST** use this child restraint in the **forward-facing** orientation, if possible. If your child **exceeds** any of the size requirements above **and** is less than 2 years old, however, you **MUST** discontinue use of this child restraint.

CHILD REQUIREMENTS

Forward-facing with Harness

- 10 to 29.4 kg (22 to 65 lbs)
- 71 to 124 cm (28 to 49 in.) and tops of the child's ears are at or below the top of the child restraint headrest
- At least 2 years old



IMPORTANT: Once your child **exceeds** any of the size requirements for **forward-facing** use above, you **MUST** discontinue use of this child restraint with its internal harness and begin using it in booster mode, if possible. If your child **exceeds** any of the size requirements for **forward-facing** use above **and** is less than 4 years old, however, you **MUST** discontinue use of this child restraint.

Booster Mode

- 18 to 54.4 kg (40 to 120 lbs)
- 112 to 145 cm (44 to 57 in.) and tops of the child's ears are at or below the top of the booster seat headrest
- At least 4 years old



IMPORTANT:

Once your child **exceeds** any of the size requirements above for **booster mode**, you **MUST** discontinue use of this seat. Your child may be ready for use of the vehicle belt system only at this time.

PREMATURE INFANT USE

Before using this child restraint for preterm or low birth weight infants, ensure the Child Requirements are met and follow the guidelines in this section.

According to the U.S. National Highway Traffic Safety Administration, a properly installed child restraint reduces the risk of death by over 70 percent for infants involved in crashes. Federal Motor Vehicle Safety Standard (FMVSS) 213 establishes design and dynamic performance requirements for child restraint systems. However, the standard has no minimum weight limit and does not address the special medical needs of preterm or low-birth weight infants. To ensure that preterm and low-birth weight infants are transported safely, the guidelines published by the American Academy of Pediatrics (AAP) in Pediatrics 2009; 123:1424–1429 must be followed.

All children should ride rear-facing in the vehicle as long as possible. Preterm and low-birth weight infants are at additional risk of breathing difficulties and heart problems when placed in a child restraint. Evenflo requires that the evaluation recommended by the AAP be conducted for all infants born earlier than 37 weeks and all newborn infants who weigh less than 5 pounds at birth before their first car trip to check for breathing difficulties or heart rate problems when traveling in a rear-facing child restraint.

The AAP recommends that appropriate hospital staff observe your infant in the child restraint for a period of 90 to 120 minutes or the duration of travel, whichever is longer. This period of observation must be performed with the infant properly positioned as described in these instructions and with the child restraint placed at an angle that is approved for use in the vehicle. The hospital staff will check for any breathing difficulties or heart rate problems. Your child's pediatrician will let you know if there are any special considerations for travel. The number of trips and the duration of time the infant is seated in the child restraint should be minimized. A caregiver should ride in the back seat to monitor the infant during travel.

You can learn more about the AAP's recommendations for observation of newborns and the guidelines for safe transportation of preterm and low-birth weight infants, as well as other resources for parents and medical professionals, at

<https://www.healthychildren.org/english/safety-prevention/on-the-go/Pages/default.aspx>

WARNING! DEATH or SERIOUS INJURY can occur.



Airbag Warning

WARNING / MISE EN GARDE



DO NOT place rear-facing child seat on front seat with air bag.
DEATH OR SERIOUS INJURY CAN OCCUR.
The back seat is the safest place for children 12 and under.

NE PAS placer un dispositif de retenue pour enfant en orientation face à l'arrière sur un siège avant doté d'un sac gonflable.
RISQUE DE DÉCÈS OU DE GRAVES BLESSURES.
Le siège arrière offre le plus de sécurité pour les enfants âgés de 12 ans ou moins.

25802179 7/10

- **DO NOT** use this child restraint in the front seat of a vehicle equipped with an air bag, unless the air bag has been deactivated. Interaction between a rear-facing restraint and air bags may cause serious injury or death. Air bags may cause serious injury or death to children 12 years of age and under. If your vehicle has an air bag, refer to your vehicle owner's manual for child restraint installation.
- If the rear seat of your vehicle is equipped with side air bags, refer to the following information for proper usage:

Vehicles built prior to the 2002 model year:

DO NOT use this restraint in a vehicle seating position equipped with a side air bag unless authorized by the vehicle manufacturer.

Model year 2002 and newer vehicles:

Refer to your vehicle owner's manual before placing this restraint in a seating position equipped with a side air bag. **DO NOT** place any objects between the restraint and the side air bag, as an expanding air bag may cause the items to strike your child.

The forward facing back seat is the safest place for children 12 and under.

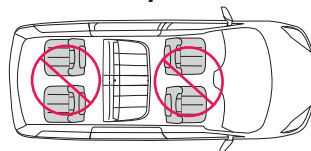

WARNING! DEATH or SERIOUS INJURY can occur.

General Warnings

- Failure to follow the Child Usage Requirements for **rear-facing, forward-facing** and **booster mode** for this child restraint could result in serious injury or death. (See page 4 for Child Requirements).
- Failure to follow installation instructions and the instructions and warning labels on product can result in the child striking the vehicle's interior during a sudden stop or crash. Serious injury or death may result. These instructions and the instructions in your vehicle owner's manual must be followed carefully. If there is a conflict between the two, the vehicle owner's manual regarding child restraint installation must be followed.
- **NEVER** leave child unattended.

WARNING/MISE EN GARDE

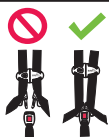

Children have **STRANGLLED** in loose or partially buckled harness straps. Fully restrain the child even when carrier is used outside the vehicle.

Des enfants se sont **ÉTRANGLÉS** dans des sangles de harnais desserrées ou mal serrées. Attacher complètement l'enfant même lorsque le porte-bébé est utilisé hors du véhicule.

- **NEVER** leave child unattended.
- **DO NOT** use child restraint if it is damaged, broken, or missing parts.
- **DO NOT** use this restraint if it has been involved in a crash. It must be replaced.

WARNING! DEATH or SERIOUS INJURY can occur.

Location Warnings

- **ALWAYS** read and follow exactly the instructions that accompany your vehicle and child restraint.
- According to accident statistics, children are safer when properly restrained in the rear seating positions than in the front seating positions. Generally, the center rear position is safest and should be used if available.
- Some child restraints do not fit all vehicles or all seating locations. There are many thousands of combinations of vehicle makes, models, child restraint configurations, vehicle seat belt designs, and seat cushion shapes. The easiest way to determine whether your child restraint is suitable for a particular seating position is to check for a tight installation. If the child restraint cannot be properly installed, **DO NOT** use the child restraint. Consult vehicle owner's manual, try a different seating location, or call Evenflo for further assistance.
- **ONLY** use this child restraint on **forward-facing vehicle seats**. **DO NOT** use this restraint with vehicle seats that face the rear or side.



- **ONLY** use this child restraint on vehicle seats with backs that lock into place.
- **VEHICLE TYPES IN WHICH THE RESTRAINT SYSTEM CANNOT BE USED:**
 - This child restraint is not to be used in vehicles that do not have vehicle seat belts or UAS lower anchorages.

WARNING! DEATH or SERIOUS INJURY can occur.

Rear-Facing ONLY Warnings

- When using this restraint rear-facing, **DO NOT** loosen the vehicle seat belt to provide more leg room, as this may keep the child restraint from protecting the child.
- Fold-down armrests could pose a hazard to a rear-facing child in certain types of collisions. Consult your vehicle owner's manual before installing any rear-facing child restraint in front of a fold-down armrest.
- **NEVER** turn a child restraint forward-facing with a child who weighs less than 10 kg (22 lbs). Crash forces may cause serious injury or death.
- **DO NOT** use the tether strap when the child restraint is in the rear-facing position.
- The headrest on the vehicle seat that the child faces when sitting in the rear-facing mode should be placed in the lowest position. The vehicle seat back that the child faces must be fully padded and free of any hard objects.
- The Anti-rebound Bar is **REQUIRED** for **REAR-FACING** use in Canada.
- **IMPORTANT:** Infants may have difficulty breathing when in an upright seated position. Make sure they recline enough for their head to lie back comfortably and safely. Failure to properly recline the child restraint could increase the child's risk of serious injury or death.

Forward-Facing ONLY Warnings

- If your child weighs more than 29.4 kg (65 lbs) or their shoulders are above the highest harness level, you **MUST** use child restraint in booster mode.
- **Adjust, or remove, the vehicle headrest in the seat where the child restraint is to be installed,** so that the back of the child restraint rests against the vehicle seat back.
- The headrest on the vehicle seat in front of the child should be put in its lowest position. The vehicle seat back that the child faces must be fully padded and free of any hard objects.
- The Anti-rebound Bar is for **REAR-FACING USE ONLY.** **NEVER** use the Anti-rebound Bar in Forward-facing or Booster Modes

WARNING! DEATH or SERIOUS INJURY can occur.

Booster Mode ONLY Warnings

- **DO NOT** use this booster seat rear-facing.
- **WARNING!** Use **ONLY** the vehicle's lap **AND** shoulder belt system when restraining the child in this booster seat.
- The shoulder belt **MUST** be threaded through the shoulder belt guide.
- **DO NOT** use this booster seat if the tops of the child's ears are above the back of the booster seat headrest.
- The shoulder belt **MUST NOT** cross the child's neck **OR** fall off the child's shoulder. If you cannot adjust the shoulder belt to properly lay midway between the child's shoulder and neck **AND** at or above the shoulder, try another seating location or do not use the booster seat.
- The Anti-rebound Bar is for **REAR-FACING USE ONLY.** **NEVER** use the Anti-rebound Bar in Forward-facing or Booster Modes



WARNING! DEATH or SERIOUS INJURY can occur.

Seat Belt Warnings

- **ALWAYS** read your vehicle owner's manual to determine what vehicle belts and retractors are used in your vehicle belt.

The vehicle belt **MUST** lock and **Retractor** **MUST NOT** loosen after the seat belt is tightened.

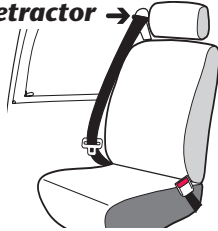

- **DO NOT** use this child restraint if it moves more than 2.5 cm (1 in.) side to side or front to back at either the rear-facing or forward-facing belt path on the child restraint. Serious injury or death may result from poor installation. If you cannot tightly secure the child restraint, try again or move it to another location.

- **DO NOT** use this child restraint in a seating position with door-mounted seat belts.



- **DO NOT** use this child restraint in a vehicle with seat belts that automatically move along the vehicle frame when the door is opened.

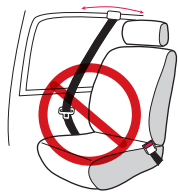

- **DO NOT** use this child restraint in a vehicle equipped with lap belts that only lock during a sudden stop or crash (emergency locking retractor – ELR). You must use a seating location with a locking seat belt. Check your vehicle owner's manual to see if you have lap belts with ELRs.



- **DO NOT** use on vehicle seats when both portions of the vehicle belts are positioned forward of the seat crease.



WARNING! DEATH or SERIOUS INJURY can occur.

Seat Belt Warnings (cont.)

- **DO NOT** use with lap/shoulder belts with two retractors. If the vehicle seat belts are not routed and fastened correctly, the child restraint may not protect the child in a crash.



- **DO NOT** use with inflatable seat belts except in booster mode.
- Check your vehicle owner's manual to determine how to lock your seat belt for child restraint installation. The seat belt must be locked to properly secure the child restraint.
- **DO NOT** allow the vehicle seat belt release button to touch the child restraint. Accidental contact may cause the seat belt to release. If necessary, turn the seat belt release button away from the child restraint or move the child restraint to a different location.
- Failure to adjust the harness or vehicle seat belts snugly around the child may result in the child striking the vehicle's interior during a sudden stop or crash. Serious injury or death may occur.
- This child restraint must be securely belted to the vehicle, **even when it is unoccupied**, since in a crash an unsecured child restraint system may injure other occupants.

LOCKING CLIP USE:

If your vehicle was built **prior to model year 1996**, and has a lap/shoulder belt that is equipped with an emergency locking retractor (ELR) AND sliding latch plate, you **MUST** use a Locking Clip. Check your vehicle owner's manual to identify which vehicle belt system is in your vehicle.

If your vehicle is **model year 1996 or newer**, it likely has a vehicle belt system that can be locked when tightened, and will not require use of a Locking Clip. **Consult your vehicle owner's manual before installing a locking clip.** If your vehicle requires a Locking Clip, please call ParentLink at 1-800-233-2229 (U.S.) and (Canada), to obtain a Locking Clip and instructions on how to install and use it. Remove Locking Clip from vehicle seat belt when not used with a child restraint, or the vehicle seat belt will not properly restrain an adult or child. Serious injury could occur.

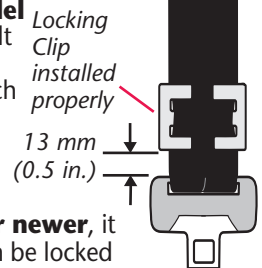

Important

WARNING! DEATH or SERIOUS INJURY can occur.

Seat Belt Warnings (cont.)

If you have any of these types of vehicle belt systems listed, these are SAFE to use to install your child restraint in the vehicle. Review vehicle owner's manual for specific instructions on child restraint installation. **LATCH** can be used IN PLACE OF these vehicle belt types. Refer to the Rear-facing and Forward-facing weight limits on **LATCH** use on pg. 29 and 40. Refer to your vehicle owner's manual for **LATCH** locations.

Lap Belt with Locking Latch Plate

Once buckled, the vehicle belt is tightened by pulling on the free end of the strap until the belt is tight.



Lap Belt with Automatic Locking Retractor (ALR)

The automatic locking retractor does not allow the lap belt to get longer once it is buckled. The vehicle belt is tightened by feeding seat belt webbing into retractor.

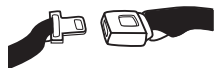

Lap/Shoulder Belt with Locking Latch Plate

The lap portion of this belt does not loosen once the belt is buckled.

The vehicle belt is tightened by pulling up hard on shoulder belt and feeding the extra webbing into the retractor.

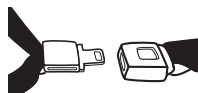

Lap/Shoulder Belt with Sliding Latch Plate with Locking Retractor

The latch plate slides freely along the lap/shoulder belt. Vehicle belts with sliding latch plates are typically locked at the shoulder belt retractor by buckling the belt and pulling all of the webbing out slowly to switch the retractor.

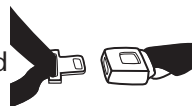

Check vehicle owner's manual for specific instructions. The vehicle belt is tightened after switching the retractor by pulling up on shoulder belt and feeding the webbing into the retractor.

WARNING! DEATH or SERIOUS INJURY can occur.

LATCH/UAS Warnings

What is **LATCH**?

LATCH is an acronym for (**L**ower **A**nchors and **T**ethers for **C**hildren) and refers to a pair of fixed Lower Anchors (or bars) and a Top Tether anchor that are built into your vehicle, in vehicles built after September 1, 2002.

The lower **LATCH** anchors are located in the crease, or bight, between the vehicle seat back and seat cushion, and if not visible, will typically be indicated by  symbols. Top tether anchors are located in various places behind the rear vehicle seat.

Vehicle Top Tether Anchor Points

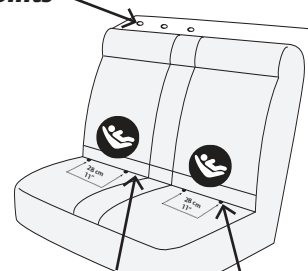

Vehicle Seat Crease

Vehicle Lower Anchors

Center installation in a non-standard LATCH position:

Center installation of this child restraint is permitted using inner Lower Anchor Bars from the outside seating positions if (1) your vehicle manual allows such installation; and (2) the inner Lower Anchor Bars from the outside seating positions are 28-51 cm (11-20 in.) apart.

LATCH typically offers an easier and more consistent installation. However, this child restraint can be safely installed using either **LATCH** or vehicle belts and meets the requirements of Federal Safety Standard FMVSS 213 with either installation method. Either method is safe for your child when installed correctly. When using either method, it is best practice to **ALWAYS** use tether when installing in the forward-facing position.

DO NOT install this child restraint with LATCH and the vehicle's seat belts at the same time. Your vehicle owner's manual may refer to this system as ISOFIX, Universal Anchorage System (UAS), or Lower Universal Anchorage System.

The **LATCH** system is intended to be used **ONLY** as described in these instructions. Serious injury or death may result from misuse. Refer to your vehicle Owner's Manual for lower anchor bar positions in your vehicle.

Important

WARNING! DEATH or SERIOUS INJURY can occur.



LATCH/UAS Warnings

- **DO NOT** use the lower anchors of the child restraint anchorage system (**LATCH** system) to attach this child restraint when restraining a child weighing more than 18 kg (40 lbs) with the internal harnesses of the child restraint. ONLY USE VEHICLE BELT INSTALLATION.
- In addition to these instructions, read and follow your vehicle owner's manual regarding installation of the child restraint and **LATCH**. If there is a discrepancy, follow your vehicle owner's manual.
- **ONLY** use for securing child restraint to vehicle lower anchor bars.
- **NEVER** attach two lower anchor connectors to one vehicle lower anchor bar.
- **NEVER** use the vehicle seat belts when using the lower anchor connector assembly. Using both together can cause slack in a sudden stop or crash.
- To avoid strangulation, you must store the unused **LATCH** straps, with all slack removed, in the storage areas on the sides of your seat. Roll or fold the excess **LATCH** strap and secure with a rubber band to prevent serious injury to vehicle occupants.
- **ALWAYS** be sure that the lower anchor connectors are attached to the vehicle lower anchor bars by pulling hard on the lower anchor connectors. If they are not attached, the lower anchor connector assembly will not secure your child restraint. Serious injury or death may result.
- **DO NOT** use this child restraint if it moves more than 2.5 cm (1 in.) side to side or front to back at either the rear-facing or forward-facing belt path on the child restraint. Serious injury or death may result from poor installation. If you cannot tightly secure the child restraint, try again or move it to another location.

WARNING! DEATH or SERIOUS INJURY can occur.



Tether Strap Warnings

- To avoid a strangulation hazard, you **MUST** tightly roll or fold excess or unused tether strap and secure with a rubber band. Attach the tether hook to the storage clip when not in use (p. 20). This will keep an unused tether or tether hook from hitting someone during a crash.

Additional Warnings

- **DO NOT** use the cup holder to store cans or hard cups. **DO NOT** place any cups that contain hot liquids in the cup holder.
- **DO NOT** attach additional padding, toys, or other devices not made by Evenflo or described in these instructions for the child restraint. Items not tested with the child restraint could injure the child. Additional pads or pillows may interfere with the function of the harness system, or cause breathing problems if the child's head falls forward, increasing the risk of serious injury or death.
- In hot or sunny weather, **ALWAYS** check the areas of the child restraint that may contact your child (e.g., buckle, buckle tongues, etc.) for hot areas before placing him/her into the child restraint. The child could be burned. Cover the child restraint with a light colored blanket when you leave the vehicle.
- In cold weather, **DO NOT** dress the child in bulky clothing like snowsuits if the child is riding in a child restraint. Bulky coats/snowsuits make it difficult to properly tighten the harness to the child, which may allow the child to be ejected from the restraint during a crash. If necessary, place a blanket over the harnessed child without interfering with the child restraint harness system.
- Failure to follow installation instructions could result in serious injury or death. These instructions and the instructions in your vehicle owner's manual must be followed carefully. If there is a conflict between the two, the vehicle owner's manual regarding child restraint installation must be followed.

Safe Practices

- **Everyone rides buckled up or the vehicle does not go.** Make no exceptions for adults or children. If someone unbuckles, stop the vehicle. Being firm and consistent from the start will mean fewer discipline problems as children get older. An unrestrained person can be thrown into and injure other passengers.
- Many safety advocates and healthcare professionals recommend that children ride rear-facing for as long as possible. See limitations recommended on rear-facing use on page 4.
- **NEVER** try to tend to a crying baby's needs while driving. **NEVER** take a baby out of a child restraint for comforting while the vehicle is moving.
- **DO NOT** allow a child in a vehicle to have objects such as lollipops or ice cream on a stick. The object can injure the child if the vehicle swerves or hits a bump.
- **DO NOT** feed an infant who is riding in a child restraint.
- Put sharp or heavy items in the trunk. Anything loose can be deadly in a crash.

For Recall Information for U.S. Customers

- Child restraints could be recalled for safety reasons. You must register this restraint to be reached in a recall. Send your name, address, e-mail address if available, and the restraint's model number and manufacturing date to:
**Evenflo Company, Inc.,
1801 Commerce Dr.,
Piqua, OH 45356**
or call 1-800-233-2229.
or register online at:
www.evenflogold.com/registercarseat
- For recall information, call the U.S. Government's Vehicle Safety Hotline at 1-888-327-4236 (TTY:1-800-424-9153), or go to:
<http://www.NHTSA.gov>

Tear off and mail this part

Consumer: Just fill in your name and address and e-mail address.

Your Name _____

Your Street Address _____

City _____ State _____ Zip Code _____

E-mail Address _____

CHILD RESTRAINT REGISTRATION CARD

Public Notice for Canadian Customers

- Child restraints could be recalled for safety reasons. You must register this restraint to be reached in a recall. Send your name, address, and the restraint's model number and manufacturing date to:

**Evenflo Company, Inc.,
1801 Commerce Dr.,
Piqua, OH 45356**

or call 1-800-233-2229.

or register online at:

www.evenflogold.ca/registercarseatcanada

- For public notice information, call Transport Canada at 1-800-333-0510 (1-613-993-9851 in Ottawa region).

CANADIAN RESIDENTS ONLY
DOMICILIÉS DU CANADA SEULEMENT

**PRODUCT REGISTRATION CARD
CARTE D'ENREGISTREMENT DU PRODUIT**

1. Name _____
2. Street Address _____
3. City _____ 4. Prov. _____
5. Postal Code _____
6. Registration Number (with Area Code) _____
7. Email Address _____
8. Date of Purchase _____

ATTENTION: This card may be important for the safety of your child. Please complete every line of this card and mail this card so that you can be contacted in the event of a safety recall on this product. **The information you provide must be complete.**
Cher registre en ligne et www.evenflogold.ca/registercarseatcanada.
ATTENTION: Cette carte pourrait être importante à la sécurité de votre enfant. Veuillez remplir cette carte et la renvoyer à notre siège social afin de pouvoir être contacté en cas d'appel de sécurité de produit. **Tous les renseignements fournis doivent être complets.** Ou enregistrez-vous en ligne à www.evenflogold.ca/registercarseatcanada.

PLACE DATE / MODÈLE # LABEL HERE
AFFRER L'ÉTIQUETTE DE LA DATE ET
DU NUMÉRO DE MODÈLE ICI

Important

Motor Vehicle/Aircraft Usage



When used with the internal harness and properly installed pursuant to these instructions, this restraint is certified for use only in passenger and multi-purpose passenger motor vehicles, buses and trucks equipped with either lap belts only or lap/shoulder belt systems and in aircraft.

Refer to pages 70 to 73 for instructions on installing your child restraint in aircraft.

When used WITHOUT the internal harness system (in booster mode) and properly installed pursuant to these instructions, this restraint is certified for use only in passenger and multi-purpose passenger motor vehicles, buses, and trucks equipped with lap/shoulder belt systems only. In booster mode, this restraint is **NOT** certified for aircraft use. A belt-positioning booster requires the use of a lap/shoulder belt system, which is not available in aircraft.



Child Restraint Features

Front



Back

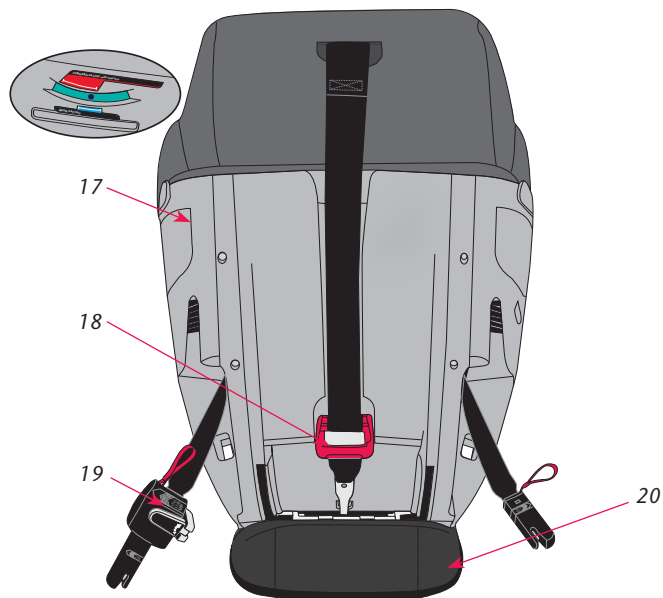

Child Restraint Features

Description

1. Adjustable Headrest
2. Harness Covers*
3. Harness Storage Compartment (behind seat pad)
4. Harness Straps
5. Harness Release Button (under flap)
6. Harness Adjust Strap
7. Recline Handle (under front edge of seat)
8. Headrest Adjust Lever
9. Instruction Manual Storage (behind headrest pad)
10. Seat Pad
11. Chest Clip
12. Body Pillow
13. Buckle
14. Crotch Strap
15. Cup Holder*
16. Recline Position Indicators
17. Level Indicator
18. Tether Strap and Hook (Shown fastened to storage clip)
19. Lower Anchor (UAS) Connector Assembly (styles may vary, see page 24)
20. Base
21. Anti-rebound Bar (Canada Only)

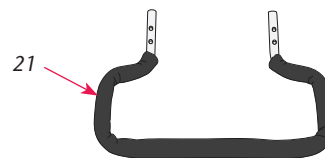

* Not all features are available on all models. Styles may vary.

Child Restraint Features (cont.)

Cupholder

⚠ WARNING

- **USE** the cup holder when the child restraint is in the forward-facing position only.
- **DO NOT** use the cup holder to store cans or hard cups.
- **DO NOT** place any cups that contain hot liquids in the cup holder.
- **DO NOT** attach any other items to this child restraint unless it has been certified for use with this specific child restraint.



To install the cup holder liners, insert into cupholder area until it snaps into place.

NOTE: Cupholder liners may be removed for cleaning. Dishwasher safe (top rack only).

Harness Covers (only on certain models)

Velcro® strips

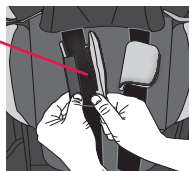

Install Harness Covers above Chest Clip. Harness covers are optional for added comfort. Wrap Harness Covers around harness straps and attach Velcro strips as shown.



Always check that the harness covers **DO NOT** bunch up when tightening the harness.

Child Restraint Features (cont.)

Body Pillow



NOTE: The body pillow is for **REAR-FACING** only use. The optional Body Pillow, when placed in the restraint, as shown, helps support your child.

Head Pillow

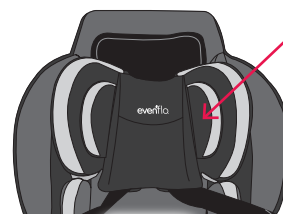

The head pillow is for **REAR-FACING** only use. The head pillow helps support your child's head.

IMPORTANT: Infants may have difficulty breathing when in an upright seated position. Using additional padding or pillows other than the Head Pillow behind the infant's head or failing to properly recline the child restraint could increase the child's risk of serious injury or death.

Child Restraint Features (cont.)

Lower Anchor Connector (UAS)

Which Type of Lower Anchor Connector Is on Your Child Restraint?

Your child restraint will have one of the two types of Lower Anchor Connectors shown below. Follow the instructions on the following pages to properly install the Lower Anchor Connector Assembly on your child restraint.

EasyClick™

Lower anchor (UAS)

Not available on all models.

Release Strap

Strap

Clip

Adjuster

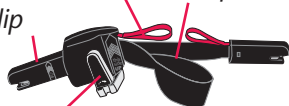

Quick Connector™

Lower anchor (UAS)

Not available on all models.

Release Strap

Strap

Clip

Adjuster



Removing the Lower Anchor Connector (UAS)

To remove the lower anchor (UAS) from its storage compartment, pull the red Release Strap.

OR

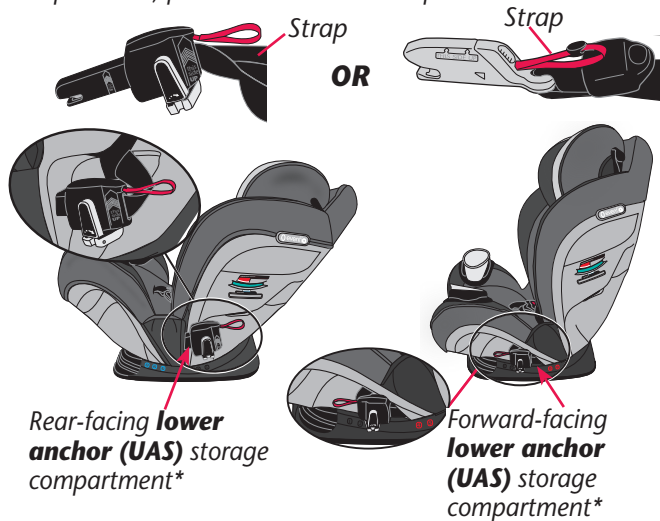

Child Restraint Features (cont.)

Storing Lower Anchor (UAS) Straps

To store the **lower anchor (UAS)** in its storage compartment, insert into the storage compartment **UNTIL** it clicks into compartment as shown below:

REAR-FACING LOWER ANCHOR (UAS) STORAGE COMPARTMENT

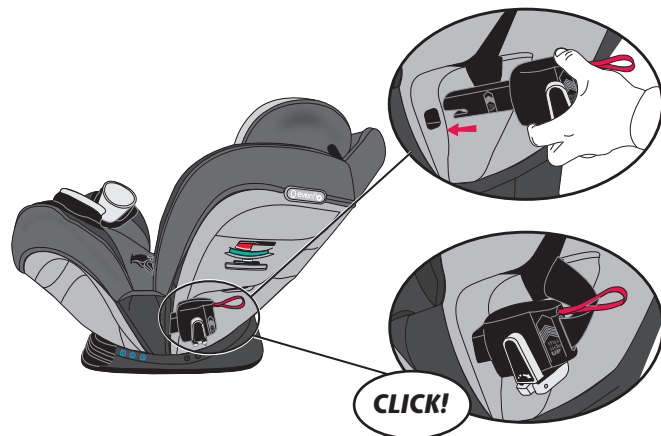

FORWARD-FACING LOWER ANCHOR (UAS) STORAGE COMPARTMENT

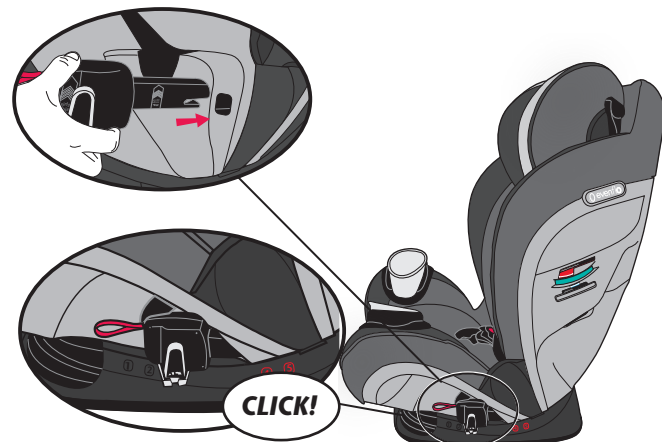

Important

Using the Child Restraint Rear-facing

!WARNING

When using this restraint rear-facing, **DO NOT** loosen the vehicle seat belt to provide more leg room as this may keep the child restraint from protecting your child.

Child Requirements:

- **Weight:** 1,8 to 22,6 kg (4 to 50 lbs)
- **Height:** 43 to 122 cm (17 to 48 in.) and top of child's head is at least 2.5 cm (1 in.) or more below the bottom of the adjustment handle

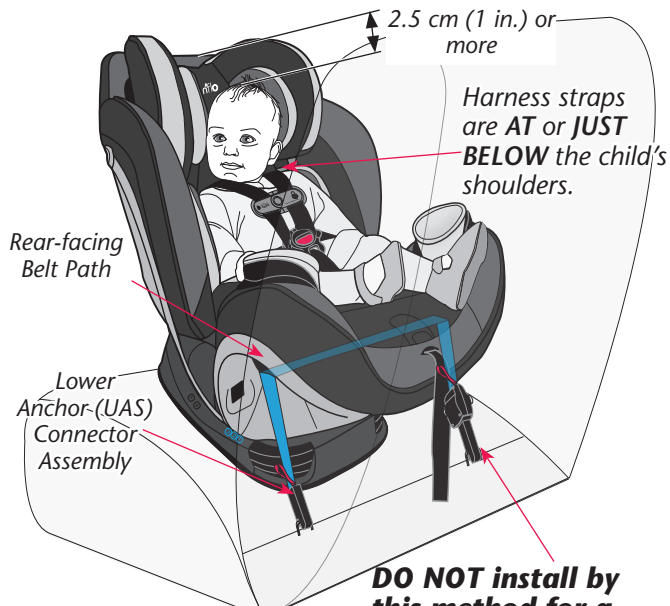

DO NOT install by this method for a child weighing more than 18 kg (40 lbs).

IMPORTANT: Once your child **exceeds** any of the size requirements above, they **MUST** use this child restraint in the **forward-facing** orientation, if possible. If your child **exceeds** any of the size requirements above **and** is less than 2 years old, however, you **MUST** discontinue use of this child restraint.

Using the Anti-Rebound Bar - Rear-facing Only

!WARNING

The Anti-rebound Bar is for use **REAR-FACING ONLY**. **NEVER** use the Anti-rebound Bar in Forward-facing or Booster Modes.

Anti-rebound bar is REQUIRED for rear-facing use in Canada.

1. Anti-rebound Bar

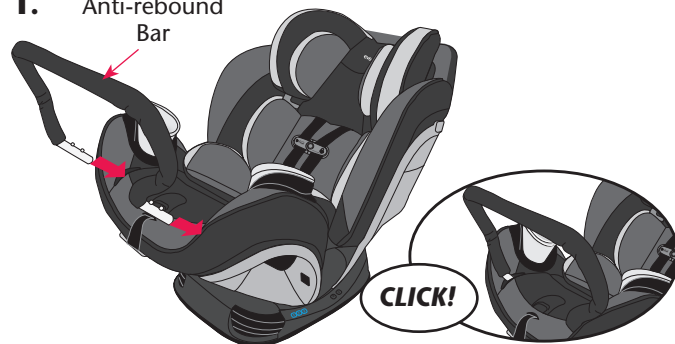

Place Anti-rebound Bar through slots in seat cover into metal tubing in seat shell.

Press the locking buttons and insert Anti-rebound Bar until both ends click into place. **Note:** Pull the Anti-rebound Bar to make sure it is locked securely.

2. Anti-rebound Bar

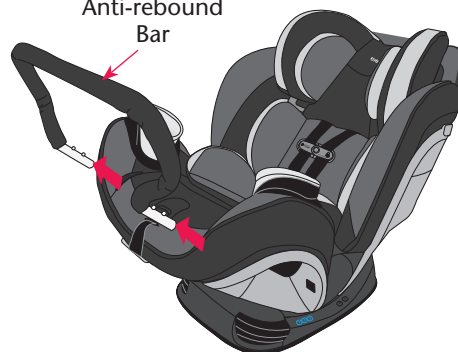

To remove the Anti-rebound Bar, press both locking buttons and withdraw the Bar from the seat.



Rear-facing Installation with Lower Anchor Connectors

Moving Lower Anchor Connector Assembly to Rear-Facing Belt path

To access the Lower Anchor Connector Assembly, you will first need to:

- Loosen internal harness straps (p. 62);
- Remove Lower Anchor Connectors (p. 24);
- Lift pad off front edge of child restraint. (p.77). *(illustrations below show pad off for clarity only)*

To install this child restraint properly in the rear-facing position, the Lower Anchor Connector Assembly **MUST** be in the rear-facing belt path.

Your car seat comes with the Lower Anchor Connector assembly installed in the rear-facing belt path.

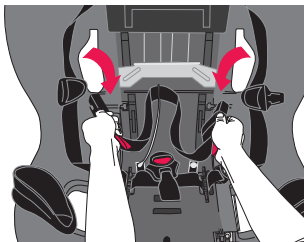

If the Lower Anchor strap is in the forward-facing belt path, follow these steps:

- Lift the seat pad off of the front edge of the child restraint.
- Pull the Lower Anchor strap to the center of the seat.
- Route the Lower Anchor strap out through the rear-facing belt path.

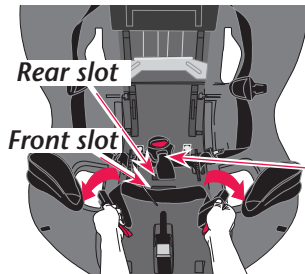

IMPORTANT:

If crotch buckle is in rear slot, place lower anchor (UAS) strap in front of buckle

If crotch buckle is in front slot, place lower anchor (UAS) strap behind buckle.

IMPORTANT: Make sure the Lower Anchor Connector strap does not interfere with the internal harness straps.

Note: After moving the Lower Anchor Connector strap, make sure the strap lies flat against the seat shell. You may have to twist the strap to achieve this.



Rear-facing Installation with Lower Anchor Connectors (cont.)

DO NOT install by this method for a child weighing more than 18 kg (40 lbs).

ALWAYS store the tether strap. (p.63). Never use tether strap when child restraint seat is rear-facing.

Infants who weigh less than 10 kg (22 lb) MUST always be rear-facing.

1. Remove Lower Anchor Connectors from sides of the seat (page 24). **CHECK** Lower Anchor strap is in rear-facing belt path (page 28).

2.

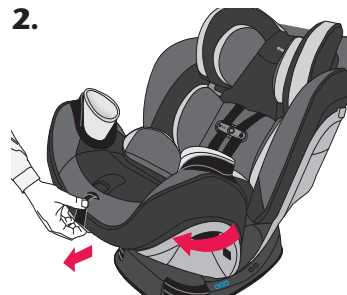

IMPORTANT: Infants may have difficulty breathing when in an upright seated position. Make sure they recline enough for their head to lie back comfortably and safely. Failure to properly recline the child restraint could increase the child's risk of serious injury or death.

Lift up on the recline lever as shown. Adjust the seat recline to **REAR-FACING Positions #1, #2, or #3 ONLY** (see below). Place child restraint **rear-facing** on approved vehicle seat. Always make sure the bottom of the child restraint sits flat on the vehicle seat.

3.

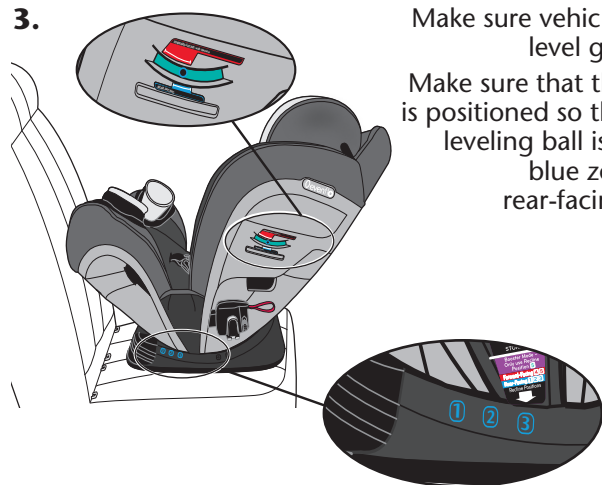

Make sure vehicle is on level ground.

Make sure that the seat is positioned so that the leveling ball is in the blue zone for rear-facing use.



Rear-facing Installation with Lower Anchor Connectors (cont.)

4. Ensure child restraint is secure.

- To secure a child restraint that has **EasyClick™** connectors, go to Step 4a.
- To secure a child restraint that has **Quick Connectors**, go to Step 4b.

4a.

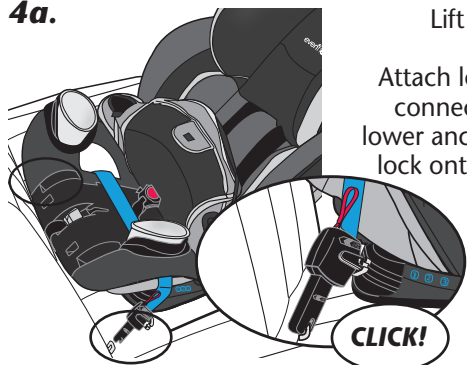

Lift pad off front edge of seat as shown. Attach lower anchor / UAS connectors to the vehicle lower anchor bars until they lock onto the bars on both sides of the seat.

IMPORTANT: Make sure both lower anchor connectors are facing upward and the straps are not twisted.

EasyClick™

Correct

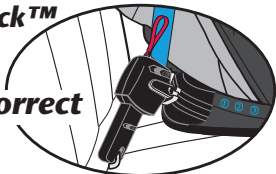

Incorrect

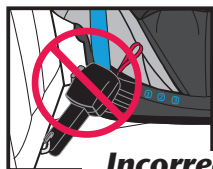

Tighten the strap by moving the handle back and forth on the lower anchor connector as shown until the seat is tight. Fold handle up after tightening.

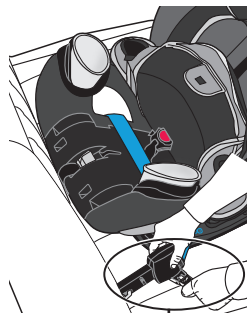

CLICK!

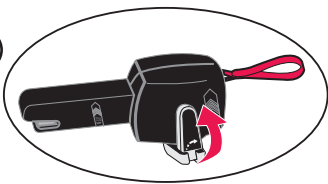

Rear-facing Installation with Lower Anchor Connectors (cont.)



4b.

Lift pad off front edge of seat as shown.

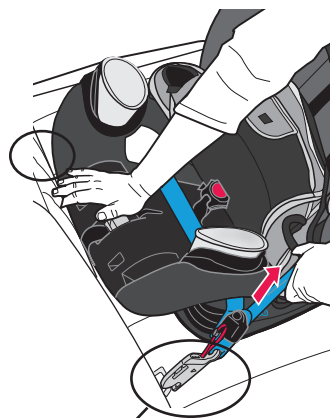

Attach lower anchor / UAS connectors to the vehicle lower anchor bars until they lock onto the bars on both sides of the seat.

Using your full weight, push the child restraint firmly into the vehicle seat while pulling up on the Lower Anchor Strap to tighten, as shown.

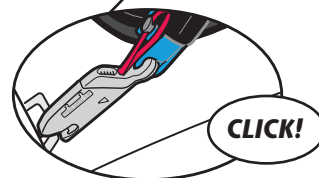

CLICK!

IMPORTANT: Make sure both lower anchor connectors are facing upward and the straps are not twisted.

Quick Connector™

Correct

Incorrect

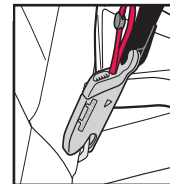

5.

Test for tightness. If you can move the child restraint more than 2.5 cm (1 in.) side to side or front to back at the rear-facing belt path, the lower anchor connector assembly strap is not tight enough.

You will need to try again, find another location for your child restraint, or install with the vehicle seat belt (p. 33).

6.

Re-attach the seat pad.



Rear-facing Installation with Lower Anchor Connectors (cont.)

7.

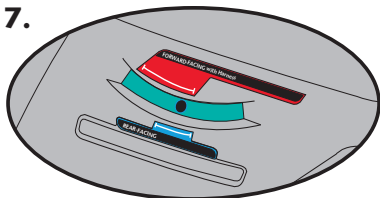

Re-check the level indicator. Ball should be between the blue zone for rear-facing.

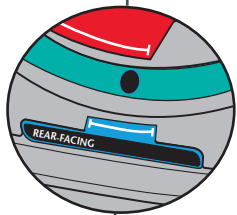

8.

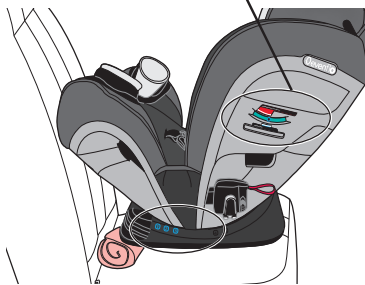

Note: In some vehicles, in the most reclined position, it may be necessary to place a tightly rolled towel or small blanket beneath the front edge of the child restraint to provide enough recline so that the leveling ball is in the blue zone for rear-facing use.

9.

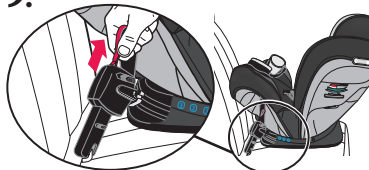

To remove the lower anchor connector assembly strap, pull red release strap. Remove the other strap on the other side of the seat from the vehicle anchor.

Rear-facing Installation with Vehicle Seat Belt



IMPORTANT:

- Before installing this child restraint rear-facing with the vehicle seat belt, you **MUST** move the Lower Anchor Connector Assembly (UAS) to the forward-facing belt path so that it does not interfere with the vehicle seat belt. Refer to (pages 39) for instructions on moving the to the forward-facing belt path.
- Check your vehicle owner's manual to determine how to lock your seat belt for child restraint installation. The seat belt must be locked to properly secure the child restraint.
- **DO NOT** use the Tether Strap when the child restraint is in the rear-facing position. Store tether, (p. 63).

1.

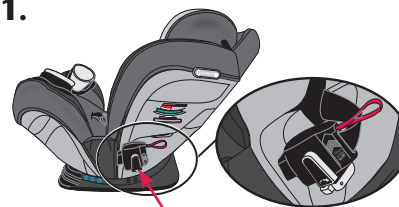

Rear-facing lower anchor (UAS) storage compartment

Re-route the lower anchor connector strap through the forward-facing belt path (p. 39). Store the lower anchor connector (UAS) in the forward-facing belt path as shown.

2.

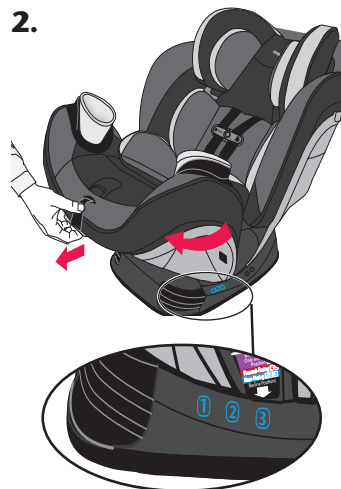

IMPORTANT: Infants may have difficulty breathing when in an upright seated position. Make sure they recline enough for their head to lie back comfortably and safely. Failure to properly recline the child restraint could increase the child's risk of serious injury or death.

Lift up on the recline lever as shown. Adjust the seat recline to **REAR-FACING Recline Positions #1, #2, or #3 ONLY**. Place child restraint rear-facing on approved vehicle seat.

Always make sure the bottom of the child restraint sits flat on the vehicle seat.

Rear-facing Installation with Vehicle Seat Belts (cont.)



3.

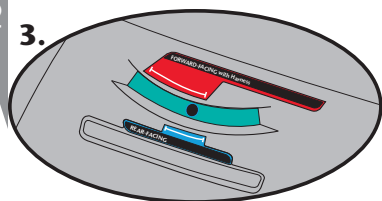

Make sure vehicle is on level ground.

Make sure that the seat is positioned so that the leveling ball is in the blue zone for rear-facing use.

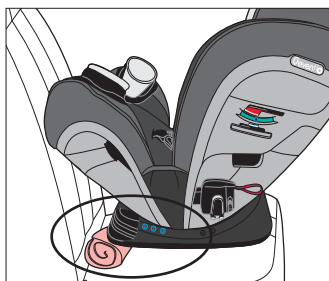
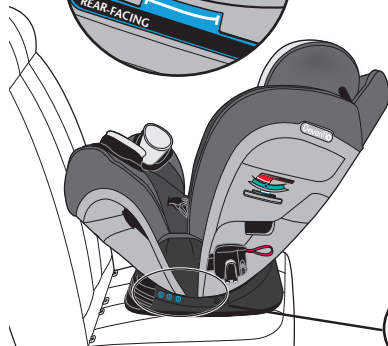
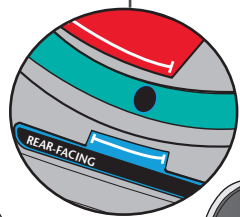

Note: In some vehicles, in **Position 1**, it may be necessary to place a tightly rolled towel or small blanket beneath the front edge of the child restraint to provide enough recline so that the leveling ball is in the blue zone for rear-facing use.

4. Ensure child restraint is secure.

- To secure a child restraint with Lap Belt, go to Step 4a.
- To secure a child restraint that has Lap/Shoulder Belt go to Step 4b.

Rear-facing Installation with Vehicle Seat Belts - Lap Belt Only



4a.

Rear-facing slot
Rear Lap belt path
Front slot

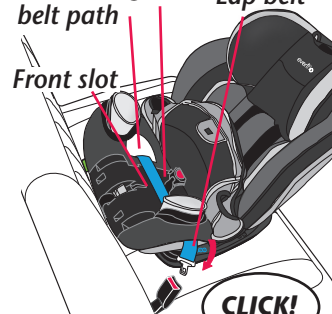

CLICK!

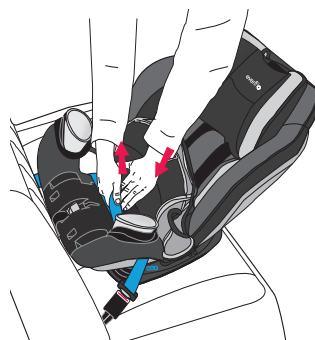

Pull the seat pad off of the front of the child restraint. Route the lap belt through the rear-facing belt path and continue through the opposite opening of the child restraint. Fasten the buckle.

IMPORTANT:

If crotch buckle is in rear slot, place vehicle belt in front of buckle.

If crotch buckle is in front slot, place vehicle belt behind buckle. Make sure the belt lies flat without twisting, as shown.

The vehicle seat belt must be as tight as possible.

Using your full weight, push the child restraint firmly into the vehicle seat as you tighten the vehicle **seat belt**, as shown. Reconnect the seat pad to the front of the child restraint.

Check your work.

Make certain the belt is tight and locked. If you can move the child restraint more than 2.5 cm (1 in.) side to side or front to back at the rear-facing belt path, the vehicle belt is not tight enough.

Re-check recline level (p.34)

If you have not tightly secured the child restraint, try again, move it to another location, or install with the lower anchor connector assembly (p. 30).

5. To remove seat, unbuckle vehicle seat belt.



Rear-facing Installation with Vehicle Seat Belts - Lap /Shoulder Belt

4b.

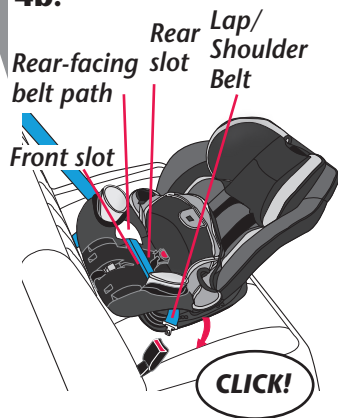

Pull the seat pad off of the front of the child restraint. Route the lap/shoulder belt through the rear-facing belt path and continue through the opposite opening of the child restraint. Fasten the buckle.

IMPORTANT:

If crotch buckle is in rear slot, place vehicle belt in front of buckle.

If crotch buckle is in front slot, place vehicle belt behind buckle. Make sure the belt lies flat without twisting, as shown.

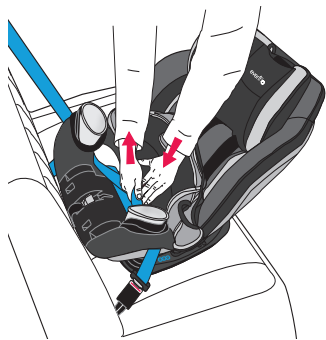

The vehicle seat belt must be as tight as possible.

Using your full weight, push the child restraint firmly into the vehicle seat as you tighten the vehicle **seat belt**, as shown. Reconnect the seat pad to the front of the child restraint.

Check your work.

Make certain the belt is tight and locked. If you can move the child restraint more than 2.5 cm (1 in.) side to side or front to back at the rear-facing belt path, the vehicle belt is not tight enough.

Re-check recline level (p.34)

If you have not tightly secured the child restraint, try again, move it to another location, install a locking clip (p.13) or install with the lower anchor connector assembly (p. 30).

5. To remove seat, unbuckle vehicle seat belt.

Rear-facing Installation Checklist

1. Secure child restraint to the vehicle seat.

- Child restraint is in Recline Position #1, #2, or #3 (pages 58).
- Anti-rebound Bar is installed (Canada Only) (p. 27).
- Install with Lower Anchor Connector (UAS) Assembly (page 30 **or** vehicle seat belt (page 33)).
- Towel rolled up and placed beneath the base, if necessary for most reclined position (page 34).
- To properly secure this child restraint it **MUST NOT** move more than 2.5 cm (1 in.) from side to side or front to back at the rear-facing belt path (pages 31 and 35-36).
- Install locking clip, if necessary (page 13).

2. Place the child in the child restraint.

- Top of head is at least 2.5 cm (1 in.) or more below the bottom of adjustment handle
- Install Body Pillow if necessary (page 23).
- The child's back and bottom are flat against the back and bottom surfaces of the child restraint.
- Harness straps **MUST** be at or just below shoulder height (page 26).

3. Fasten the buckle. Refer to page 61.

- Buckle tongues are fully engaged (page 61).

4. Make necessary adjustments.

- Crotch strap should be snug against the child (page 61).
- Harness straps **MUST** be snug against the child's shoulders, with no slack (page 61).
- Harness straps **MUST** start at or just below the child's shoulders (p. 26).
- The leveling ball is in the blue zone for rear-facing use (pages 32 and 34).

5. Position and connect chest clip.

- Chest clip **MUST** be at armpit level (page 61).

Using the Child Restraint Forward-facing with Harness

Child Requirements:

- **Weight:** 10 to 29.4 kg (22 to 65 lbs)
- **Height:** 71 to 124 cm (28 to 49 in.) and tops of child's ears are at or below the top of the child restraint headrest.
- **Age:** At least 2 years old

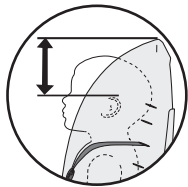

⚠ WARNING

NEVER use the Anti-rebound Bar in Forward-facing Mode.

IMPORTANT:

When installing this child restraint with Lower Anchor (UAS) Connectors or the vehicle seat belt, always use the top anchorage strap (tether), if a tether anchor is available.

DO NOT install by this method for a child weighing more than 18 kg (40 lbs).

Harness straps are **AT** or **JUST ABOVE** the child's shoulders.

Lower Anchor Connector (UAS) Assembly

Tether Strap

Forward-facing Belt Path

Lower Connector (UAS) Assembly

IMPORTANT: Once your child **exceeds** any of the size requirements for **forward-facing with harness** use above, you **MUST** discontinue use of this child restraint with its internal harness and begin using it in booster mode.

Forward-facing Installation with Lower Anchor Connectors



Moving Lower Anchor Connector Assembly to Forward-facing Belt path

To access the Lower Anchor Connector Assembly, you will first need to:

- Loosen internal harness straps (p. 62);
- Remove Lower Anchor Connectors (p. 24);
- Unfasten snaps on headrest and back pad. (p.57). *(illustrations below show pad off for clarity only)*

To install this child restraint properly in the forward-facing position, the Lower Anchor Connector (UAS) Assembly **MUST** be in the forward-facing belt path.

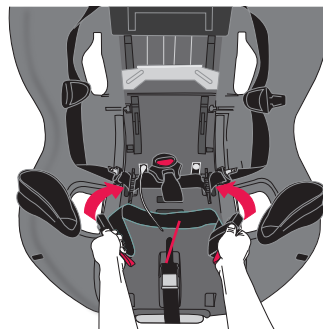

If the Lower Anchor Connector strap is in the rear-facing belt path, follow these steps:

- Raise the headrest to its highest level (p. 58).
- Unfasten snaps on headrest and back pad. (p.57).
- Pull the Lower Anchor Connector strap to the center of the seat.
- Route the Lower Anchor Connector strap out through the forward-facing belt path.
- Re-attach the seat pad.

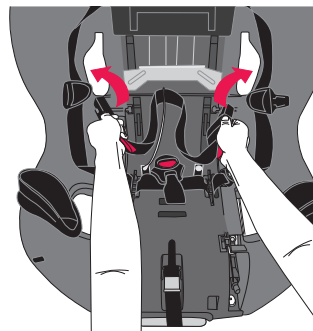

IMPORTANT: Make sure the Lower Anchor Connector strap does not interfere with the internal harness straps.

Note: After moving the Lower Anchor Connector strap, make sure the strap lies flat against the seat shell. You may have to twist the strap to achieve this.

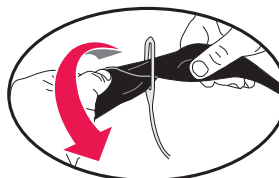

Forward-facing



Forward-facing Installation with Lower Anchor Connectors (cont.)

DO NOT install by this method for a child weighing more than 18 kg (40 lbs).

Infants who weigh less than 10 kg (22 lb) **MUST** always be rear-facing.

ALWAYS USE TETHER STRAP, if a Tether Anchor is available. If not available, ALWAYS store the Tether Strap (p. 63).

1. Remove Lower Anchor Connectors from sides of the seat (page 24). **MAKE SURE** Lower Anchor strap is in forward-facing belt path (page 39).

2. Lift up on the recline lever as shown and adjust the seat recline to **FORWARD-FACING Positions #4 or #5 ONLY** (see below).



3. Place child restraint in your vehicle **forward-facing**, as shown. Always make sure the bottom of the child restraint sits flat on the vehicle seat.

Tether Strap

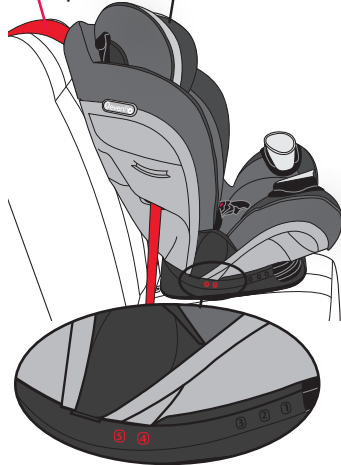

Unhook tether strap from the rear of the child restraint and place tether hook with **red adjuster** (p. 63) over back of vehicle seat. Make sure that the seat is positioned so that the leveling ball is in the red zone for forward-facing use.

Forward-facing Installation with Lower Anchor (UAS) Connectors (cont.)



4. **Ensure child restraint is secure.**

- To secure a child restraint that has **EasyClick™** connectors, go to Step 4a.
- To secure a child restraint that has **Quick Connectors**, go to Step 4b.

4a.

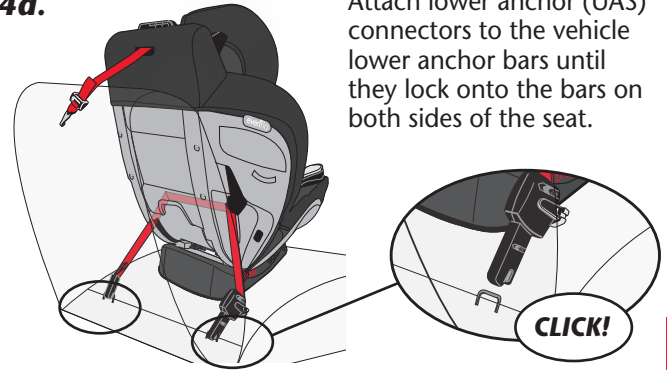

Attach lower anchor (UAS) connectors to the vehicle lower anchor bars until they lock onto the bars on both sides of the seat.

IMPORTANT: Make sure both lower anchor connectors are facing upward and the straps are not twisted.

EasyClick™

Correct

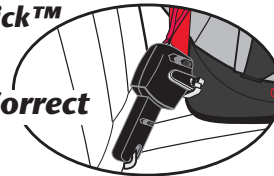

Incorrect

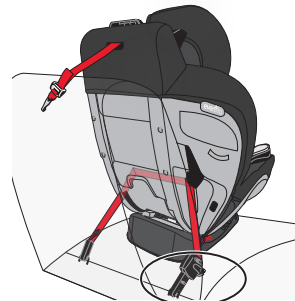
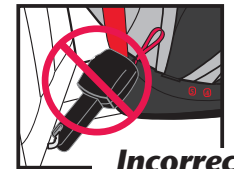

Tighten the strap by moving the handle back and forth on the lower anchor connector as shown until the seat is tight. Fold handle up after tightening.

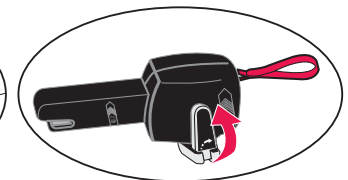
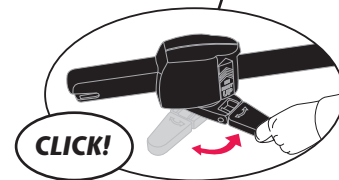



Forward-facing Installation with Lower Anchor (UAS) Connectors (cont.)

TOC

4b.

Attach lower anchor / UAS connectors to the vehicle lower anchor bars until they lock onto the bars on both sides of the seat.

Using your full weight, push the child restraint firmly into the vehicle seat while pulling up on the Lower Anchor Strap to tighten and remove all slack, as shown.

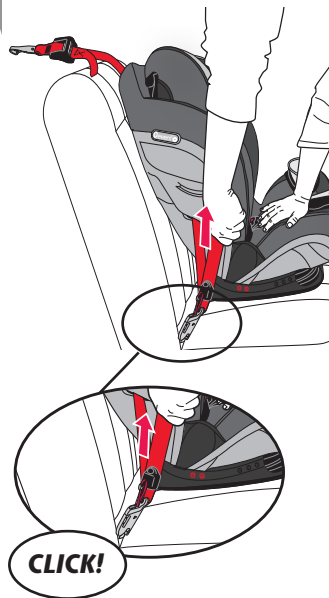

IMPORTANT: Make sure both lower anchor connectors are facing upward and the straps are not twisted.

Quick Connector™ Correct

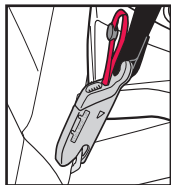

Incorrect

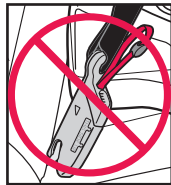

5.

Test for tightness. If you can move the child restraint more than 2.5 cm (1 in.) side to side or front to back at the rear-facing belt path, the lower anchor connector assembly strap is not tight enough.

You will need to try again, find another location for your child restraint, or install with the vehicle seat belt (p. 45).

6.

Re-attach the seat pad.

Forward-facing Installation with Lower Anchor Connectors (cont.) - Attaching Tether Strap



7.

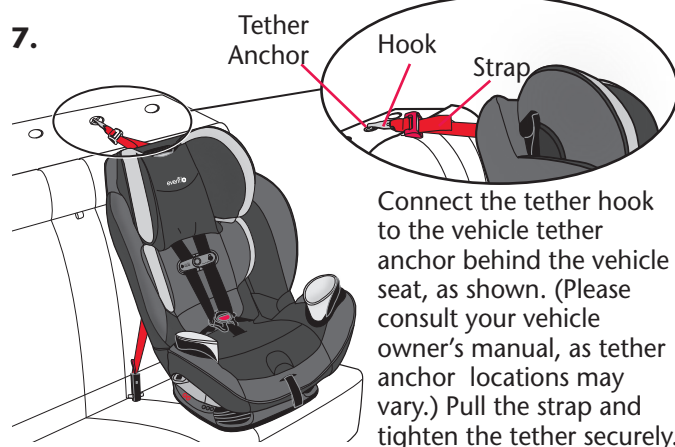

Connect the tether hook to the vehicle tether anchor behind the vehicle seat, as shown. (Please consult your vehicle owner's manual, as tether anchor locations may vary.) Pull the strap and tighten the tether securely.

⚠ WARNING

- Failure to follow these instructions could result in serious injury to your child or other vehicle occupants.
- The tether strap is for **forward-facing use only**.
- To avoid a strangulation hazard, you **MUST** tightly roll or fold excess tether strap and secure with the strap/rubber band.
- Attach the tether hook to the storage clip on the seat when not in use (**rear-facing mode only**). This will keep an unused tether or tether hook from hitting someone during a crash.

After adjusting the tether strap, you may have excess strap; **DO NOT** cut it off. If you do, it may not be long enough to use in another vehicle. Instead, tightly roll up the excess tether strap and place the rubber band around the bundle.

Note: Refer to your vehicle owner's manual for the location of the tether anchor in your vehicle. Older vehicles may not come equipped with tether anchor hardware. Check with your vehicle dealer.

- The Tether Strap **MUST** be used when installing this child restraint forward-facing with a vehicle seat belt if a Tether Anchor is available.
- If your Tether Strap is too short to reach from your child restraint to your Tether Anchor, you will need a Tether Extender. Please call Parentlink at 1-800-233-2229 (U.S.) or (Canada).

Forward-facing



Forward-facing Installation with Lower Anchor (UAS) Connectors (cont.)

8.

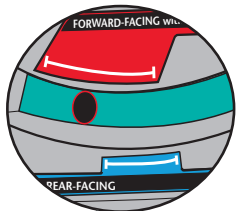

Re-check the level indicator. Ball should be between the red zone for forward-facing.

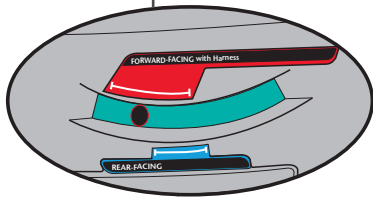

9.



To remove the lower anchor connector assembly strap, pull red release strap. Remove the other strap on the other side of the seat from the vehicle anchor.

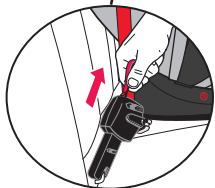

Forward-facing Installation with Vehicle Seat Belt



IMPORTANT:

- Before installing this child restraint forward-facing with the vehicle seat belt, you **MUST** move the Lower Anchor Connector (UAS) Assembly to the rear-facing belt path so that it does not interfere with the vehicle seat belt. Refer to (pages 28) for instructions on moving the to the forward-facing belt path.
- Check your vehicle owner's manual to determine how to lock your seat belt for child restraint installation. The seat belt must be locked to properly secure the child restraint.
- **ALWAYS USE TETHER STRAP, if a Tether Anchor is available. If not available, ALWAYS store the Tether Strap (p. 63).**

1.

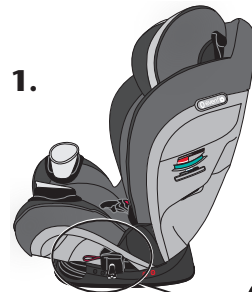

Re-route the lower anchor connector strap through the rear-facing belt path (p. 28). Store the lower anchor connector (UAS) in the rear-facing belt path as shown.

Forward-facing lower anchor (UAS) storage compartment

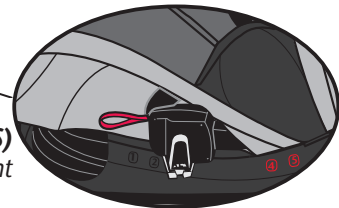

2.



Lift up on the recline lever as shown and adjust the seat recline to **FORWARD-FACING Recline Positions #4 or #5 ONLY.**



Forward-facing Installation with Vehicle Seat Belt (cont.)

3.

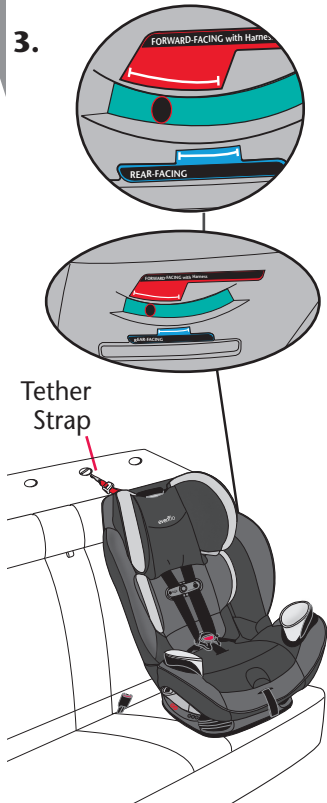

Place child restraint in your vehicle **forward-facing**, as shown. Always make sure the bottom of the child restraint sits flat on the vehicle seat. Unhook tether strap from the rear of the child restraint and place tether hook with **red adjuster** (p.63) over back of vehicle seat. Make sure that the seat is positioned so that the leveling ball is in the red zone for forward-facing use.

4. Ensure child restraint is secure.

- To secure a child restraint with Lap Belt, go to Step 4a.
- To secure a child restraint that has Lap/Shoulder Belt go to Step 4b.

Forward-facing Installation with Vehicle Seat Belt - Lap Belt



4a.

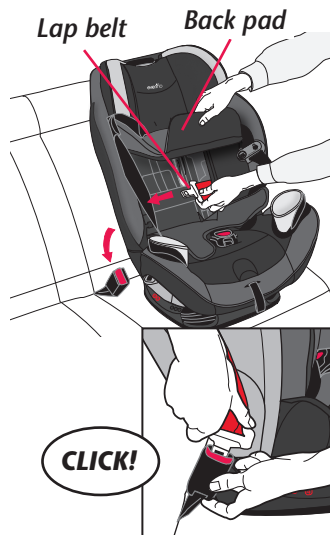

Raise headrest to its highest position (pg. 58), then lift back pad away from child restraint for easier access. Route the lap belt through the forward-facing belt path and continue through the opposite opening of the child restraint. Fasten the buckle.

IMPORTANT: Make sure the lap belt lies flat without twisting.

The vehicle seat belt must be as tight as possible. Using your full weight, push the child restraint firmly into the vehicle seat as you tighten the vehicle **seat belt**, as shown. Lower the back pad.

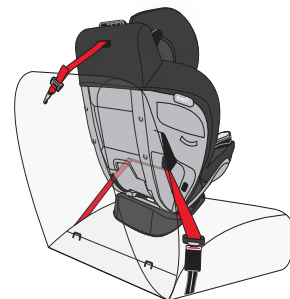



Forward-facing Installation with Vehicle Seat Belts - Lap/Shoulder Belt

4b.

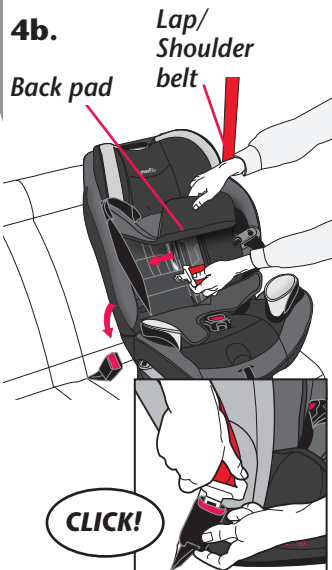

Raise headrest to its highest position (pg. 58), then lift back pad away from child restraint for easier access. Route the lap/shoulder belt through the forward-facing belt path and continue through the opposite opening of the child restraint. Fasten the buckle.

IMPORTANT: Make sure the lap/shoulder belt lies flat without twisting.

The vehicle seat belt must be as tight as possible.

Using your full weight, push the child restraint firmly into the vehicle seat as you tighten the vehicle **seat belt**, as shown. Lower the back pad.

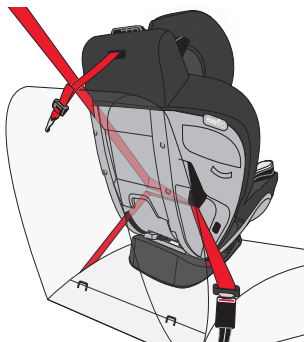

5.

Check your work.

Pull on the belt to make sure it's tight and locked. If you can move the child restraint more than 2.5 cm (1 in.) side to side or front to back at the forward-facing belt path, the vehicle belt is not tight enough.

If you have not tightly secured the child restraint, try again, move it to another location, or install with the lower anchor connector assembly (p. 40).

Continue with Step 6 to install tether strap.

Forward-facing Installation with Vehicle Seat Belts - Attaching Tether Strap



6.

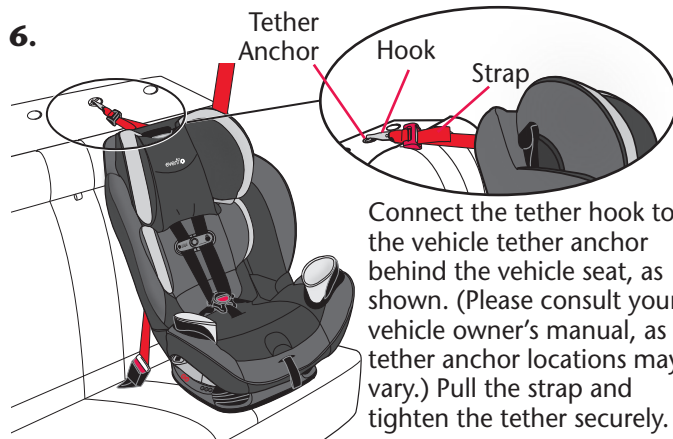

Connect the tether hook to the vehicle tether anchor behind the vehicle seat, as shown. (Please consult your vehicle owner's manual, as tether anchor locations may vary.) Pull the strap and tighten the tether securely.

WARNING

- Failure to follow these instructions could result in serious injury to your child or other vehicle occupants.
- The tether strap is for **forward-facing use only**.
- To avoid a strangulation hazard, you **MUST** tightly roll or fold excess tether strap and secure with the strap/rubber band.
- Attach the tether hook to the storage clip on the seat when not in use (**rear-facing mode only**). This will keep an unused tether or tether hook from hitting someone during a crash.

After adjusting the tether strap, you may have excess strap; **DO NOT** cut it off. If you do, it may not be long enough to use in another vehicle. Instead, tightly roll up the excess tether strap and place the rubber band around the bundle.

Note: Refer to your vehicle owner's manual for the location of the tether anchor in your vehicle. Older vehicles may not come equipped with tether anchor hardware. Check with your vehicle dealer.

- The Tether Strap **MUST** be used when installing this child restraint forward-facing with a vehicle seat belt if a Tether Anchor is available.
- If your Tether Strap is too short to reach from your child restraint to your Tether Anchor, you will need a Tether Extender. Please call Parentlink at 1-800-233-2229 (U.S.) and (Canada).



Forward-facing Installation with Vehicle Seat Belts

7.

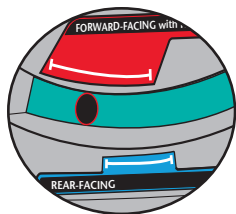

Re-check the level indicator. Ball should be in between the red zone for forward-facing.

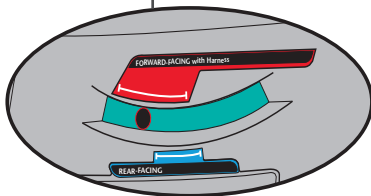

8.

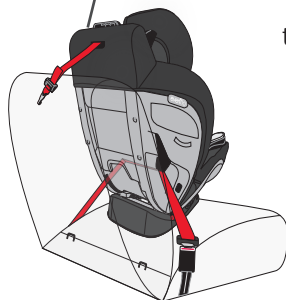

To remove the seat, unbuckle the vehicle belt.

Forward-facing CHECKLIST

1. Secure child restraint to the vehicle seat.

- Child restraint is in Position #4 or #5 (pages 58).
- Anti-rebound Bar has been removed for forward-facing use. (p. 27).
- Child restraint base sits flat on vehicle seat.
- To properly secure this child restraint it **MUST NOT** move more than 2.5 cm (1 in.) from side to side or front to back at the forward-facing belt path (pages 42 and 47-48).
- Install with Lower Anchor connector Assembly (page 40) **or** vehicle seat belt (page 45).
- Tether strap is securely attached and tightened (page 43 or 49).
- Install locking clip, if necessary (pg. 13).

2. Place the child in the child restraint.

The top of the child's ears are at or above the top of the child restraint headrest.

- The child's back and bottom are flat against the back and bottom surfaces of the child restraint.

3. Fasten the buckle. Refer to page 61.

- Buckle tongues are fully engaged (page 61).

4. Make necessary adjustments.

- Crotch strap should be snug against the child (page 61).
- Harness straps **MUST** be snug against the child's shoulders, with no slack (page 61).
- Harness straps **MUST** start at or above shoulder height (page 38).
- The leveling ball is in the red zone for forward-facing use (pages 44 and 50).

5. Position and connect chest clip.

- Chest clip **MUST** be at armpit level (page 61).

Using the Child Restraint in Booster Mode

Child Requirements

- **Weight:** 18 to 54,4 kg (40 to 120 lbs)
- **Height:** 112 to 145 cm (44 to 57 in.) and tops of the child's ears are below the top of the child restraint headrest.
- **Age:** At least 4 years old

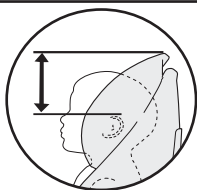

⚠️ WARNING

NEVER use the Anti-rebound Bar in Booster Mode.

The shoulder belt **MUST** pass through shoulder belt guide and the belt guide should be **even with or just above** the shoulders.

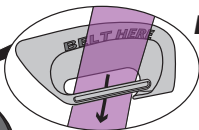

Rear view of belt guide

The shoulder belt **MUST** cross midway between child's shoulder and neck.

The lap belt is stretched low and snug across the child's hips, within the lower belt guides, and fastened into the buckle.

- **Never use a booster with only a lap belt.**



IMPORTANT: Once your child **exceeds** any of the size requirements above for **booster mode**, you **MUST** discontinue use of this seat. Your child may be ready for use of the vehicle belt system only at this time.

When to Put Your Child in a Booster Seat

Booster seats raise the child up and help to position the vehicle lap and shoulder belt correctly. When the child is properly restrained in a booster seat, his/her risk of injury in all types of crashes is reduced, as the lap and shoulder belt provides excellent restraint of both the upper and lower torsos.

It is important for the child to sit properly within the vehicle seat belts. When the vehicle belt is buckled, the lap belt should be low on the hips, just touching the thighs, and the shoulder belt should lie across the middle of the shoulder. If the child leans out or moves the belt behind the back or places it under the arm, it will not provide the intended restraint.

There are a number of things to consider when deciding whether a child is ready to sit in a booster seat, including: the weight and height ratings on his/her current child seat, the child's own weight and height, his/her maturity, and the seating positions available in your vehicle.

How is a booster seat used?

Using a booster seat is very similar to buckling yourself into the vehicle:

- Read the instruction manuals for both the booster seat and the vehicle before you start.
- Put the booster in the back seat in a location with a lap and shoulder belt. **Never use a booster with only a lap belt**, as this could cause serious injuries.
- After the child is in the booster, pull the lap and shoulder belt across him/her and buckle it.
- Check that the shoulder belt lies across the middle of the shoulder and that the lap belt is low on the hips, just touching the thighs.

When to Put Your Child in a Booster Seat

How can you tell if a child is ready to transition to a booster seat?

You should consider using a booster seat if the following conditions apply:

- The child is mature enough to sit in the booster seat and not put the belts under his/her arm or behind his/her back.
- The child is approaching the weight or height limit of the child restraint he/she is currently using. (Even children who have not outgrown their toddler seat can benefit from the use of a booster seat, if it is used properly.)
- If you have a vehicle that does not have a tether anchorage but has lap/shoulder belts available in the back seat, a booster seat may provide better protection than an internal harness seat without the tether.

The shoulder belt **MUST** pass through **shoulder belt guide**.

Rear view of belt guide

The shoulder belt **MUST** cross midway between child's shoulder and neck.

The lap belt is stretched low and snug across the child's hips, within the lower belt guides, and fastened into the buckle.

Booster Installation Checklist

1. Convert child restraint to booster seat.

See "Converting into a Booster Seat," p. 56.

2. Secure booster seat to the vehicle seat.

Make sure the seat base is level with ground (p. 54). Make sure the bottom and back of the booster seat are touching vehicle seat and back.

IMPORTANT: You may use the Tether Strap and Lower Anchor Connectors to secure this booster seat to the vehicle seat as long as the position of the booster seat in the vehicle and/or the resulting fit of the vehicle seat belt over the child are not affected.

3. Place the child in the booster seat.

- ✓ Make sure the booster seat is securely locked into Recline Position #5 (p. 58).
- ✓ Make sure the child's back and bottom are flat against the back and bottom surfaces of the booster seat.

4. Adjust headrest for proper shoulder belt fit.

The shoulder belt **MUST** cross midway between the child's shoulder and neck.

5. Secure child and booster seat to vehicle seat.

Stretch the lap/shoulder belt across the child and fasten the buckle. Make certain the shoulder belt is threaded through the shoulder belt guide.

6. Check your work.

Make sure the lap belt is stretched low and snug across the child's hips, within the lower belt guides, and fastened into the buckle. The shoulder belt must cross the child midway between his/her shoulder and neck.



⚠ WARNING

The shoulder belt **MUST NOT** cross the child's neck or fall off the child's shoulder. If you cannot adjust the shoulder belt to properly lay midway between the child's shoulder and neck **AND** at or above the shoulder, try another seating location or do not use the booster seat.

Converting Seat into Booster Mode

1.

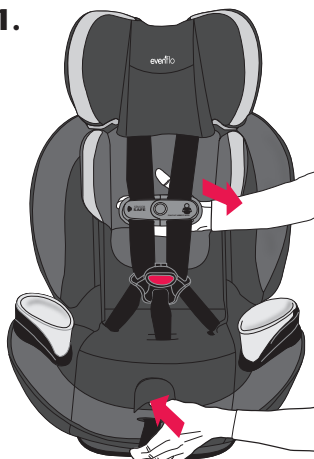

Loosen harness straps by pushing the harness release button on the front of the seat. At the same time, pull on the harness straps.

Raise the headrest to highest position (p.58).

Unfasten the chest clip and buckle.

2.

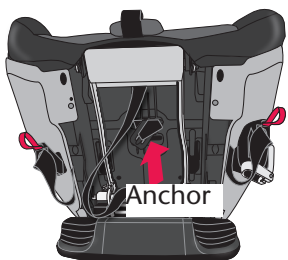

Remove the crotch buckle from the crotch slot. Recline the seat to **Recline Position 1** and turn the anchor and push it up through slot in the seat. Pull crotch buckle off seat.

Unfasten two snaps at the harness slot openings where the shoulder straps come out then unfasten snaps on the inside of the seating area.

Pull the back pad forward.

Push the shoulder straps behind the headrest pad.

3.

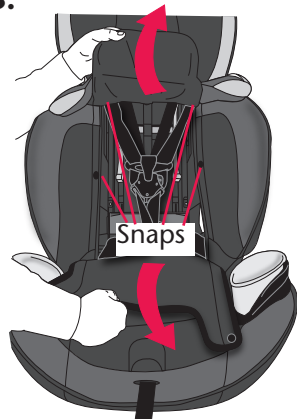

Converting Seat into Booster Mode (cont.)

4.

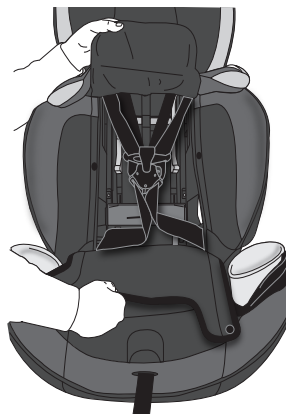

Reassemble the loose crotch buckle onto the shoulder straps and fasten the chest clip.

Flip the crotch buckle over the assembled chest clip.

Push the fully assembled harness into the open compartment as shown.

5.

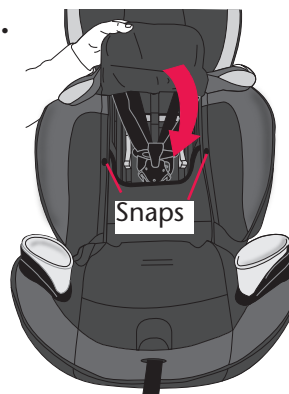

Raise back pad and fasten the two snaps on side of seat pad then lower the headrest pad. Re-fasten the snaps at the shoulder strap openings.

6.

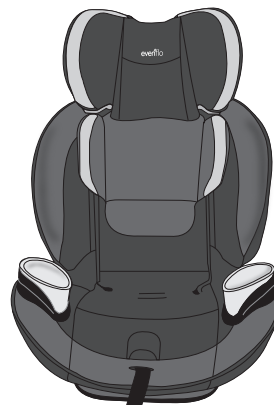

Adjust booster seat to **Recline Position 5-ONLY** (p. 58).

Booster Mode is complete.

Reverse steps to convert back to Forward-facing harness mode.

Adjusting the Headrest/ Harness Position

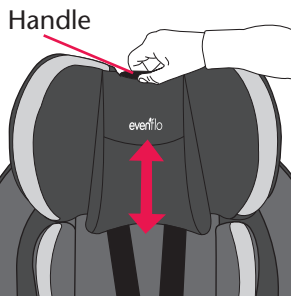

To adjust, squeeze the headrest adjust handle, as shown, while sliding the headrest up or down to the desired position. When the headrest is in one of the locking positions, the adjust lever will pop into its original position.

Note: You may need to loosen the harness straps to adjust the headrest (p. 62).

Rear-facing: Start with the headrest in its lowest position. Adjust headrest so the harness straps are **at or just below** the child's shoulders.

Forward-facing: Start with the headrest in its highest position. Adjust headrest so the harness straps are **at or just above** the child's shoulders.

Reclining Child Restraint

REAR-FACING POSITIONS

When the seat is reclined to **Recline Positions 1, 2 or 3** the ball must fall into the blue zone as shown.

FORWARD-FACING POSITIONS

When the seat is placed into **Recline Positions 4 or 5**, the ball must fall into the red zone as shown.

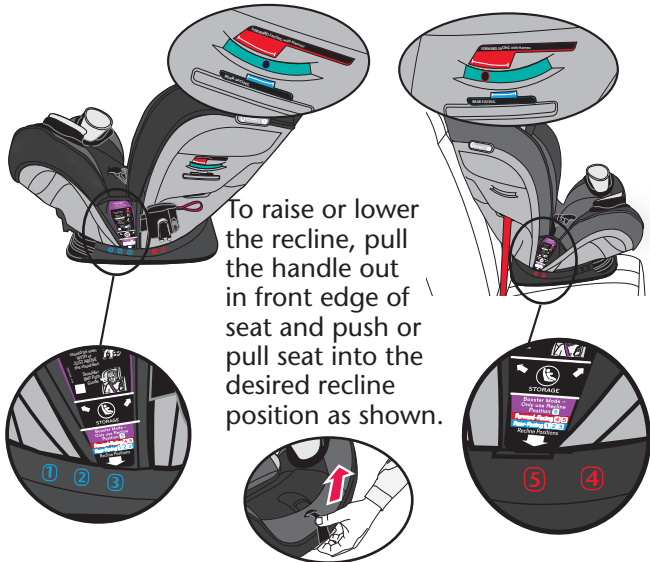

To raise or lower the recline, pull the handle out in front edge of seat and push or pull seat into the desired recline position as shown.

Adjusting the Crotch Strap Position

This child restraint has two Crotch Strap positions:

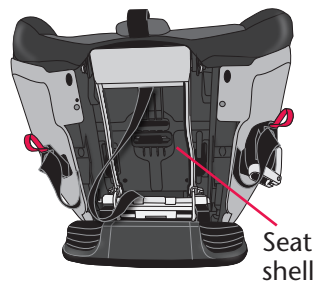
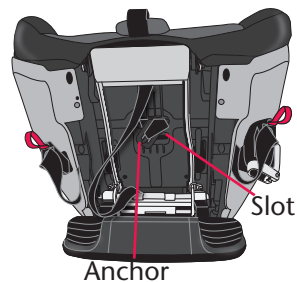

To reposition the crotch strap, first recline the seat to Recline Position #1 (p. 58). Looking under the front of the seat, turn the crotch strap harness anchor sideways and push it through the slot in the bottom of the seat shell. Reposition the crotch strap into the other slot. Make certain the crotch strap is properly seated against the seat shell.

Note: The crotch strap should be snug against the child. Choose the slot that is closest to the child **AND** the most comfortable for the child but **NEVER** under the child's bottom.

For Newborn Position

Place the anchor through the front slot, then feed it through the rear slot.

Make sure the anchor is completely through the rear slot and is lying flat against the bottom of the seat.

IMPORTANT: Do not use this configuration for infants weighing more than 4.5 kg (10 lbs).



Bottom view

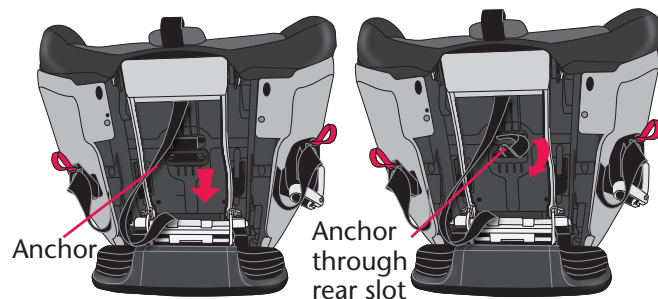

Securing the Child in the Child Restraint



Place baby in the child restraint. **The baby's back and bottom should be flat against the restraint.** If there is a gap, the baby will not be comfortable.

1. Push the harness release button on the front of the seat. At the same time, pull on the harness straps.

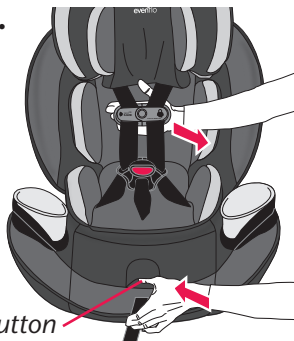

Button

2. Unbuckle harness and unfasten chest clip (p. 62).



Place the child in the child restraint. Check the crotch strap position, see page 59 to change positions.

Bring each harness strap over the child's shoulders.

3. **Rear-facing:** Start with the headrest in its lowest position. Adjust headrest so the harness straps are **at or just below** the child's shoulders.



Forward-facing: Start with the headrest in its highest position. Adjust headrest so the harness straps are **at or just above** the child's shoulders.

Note: The child's head should be centered within the headrest foam.

Securing the Child in the Child Restraint (cont.)

4. Insert both buckle tongues into the buckle. Pull up on the harness strap to check that the buckle tongues are fastened and to remove any slack from the webbing around the child's legs.

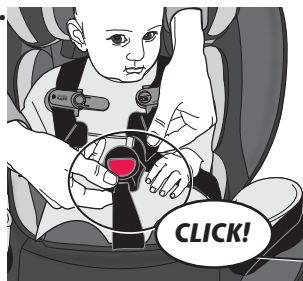

5. Snap the two halves of the chest clip together, as shown, and slide to armpit level.

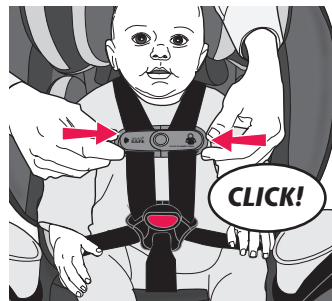

6. Hold the chest clip while pulling the harness adjustment strap so that the chest clip does not ride up into the child's neck. The harness straps must be snug against the child. A snug strap should not allow any slack. It lies in a relatively straight line without sagging. It does not press on the child's flesh or push the child's body into an unnatural position.

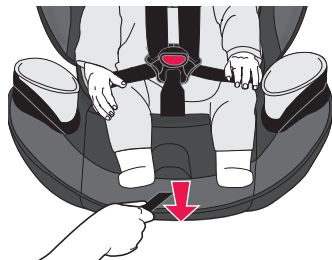

Check the harness straps near the shoulders for slack. You should **NOT** be able to pinch the harness (see illustration). Adjust as needed.

Removing the Child from the Child Restraint

1.



Loosen the harness strap by pressing the harness release button located on the front of the seat. While pressing the button, pull out on the harness straps.

2.



To unfasten the chest clip, push the release button and pull apart.

3.

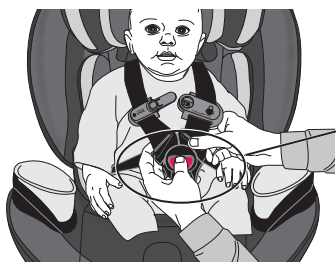

Press the red buckle release, and remove the buckle tongues.



Removing the Tether Strap

⚠ WARNING!

- To avoid a strangulation hazard, you **MUST** tightly roll or fold excess tether strap and secure with the strap/rubber band.
- Attach the tether hook to the storage clip on the seat when not in use (**rear-facing mode only**). This will keep an unused tether or tether hook from hitting someone during a crash.

TIP!

Push the child restraint into the vehicle seat back while loosening the adjuster

1. Press the adjuster release button to loosen tether strap.



2.

- Press the tab and twist, then remove the hook from the anchor.

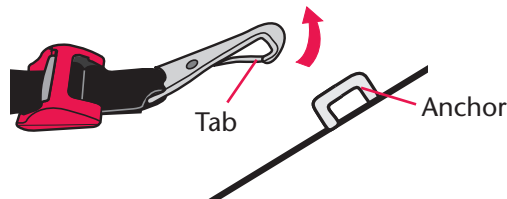

3.

- **TO STORE:** When the tether strap is not in use you **MUST** attach the hook to the back of the child restraint, slide excess strap behind the clip.
- A loose tether strap and hook may injure your child.
- To remove, see Step 2 above.

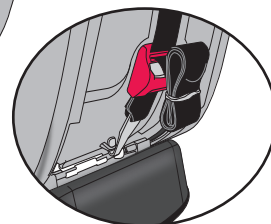
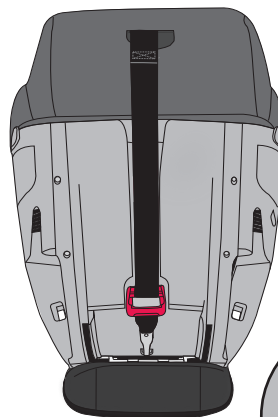

! WARNING

NEVER INSTALL or use this Child Restraint until you have read and understand the instructions in this manual **AND** in your vehicle Owner's Manual. If there is a conflict between the two, the vehicle Owner's Manual must be followed.

This system works with the SensorSafe Application which can be downloaded from: The App Store® or Google Play™.**

The SensorSafe Application* can provide the following information directly to your smartphone:

- Reminder that your child is still in your automobile
- Current temperature of your automobile interior
- User Manuals
- Installation Videos
- Customer care contact information

SensorSafe™ Technology

Questions? Comments?:

Visit us at: www.evenflogold.com

Or call ParentLink at: 1-800-233-2229 (U.S.), and (Canada).

Secure your child into the child restraint as you would normally. The SensorSafe Receiver Plug monitors both the Chest Clip Transmitter and the vehicle. When you arrive at your destination and turn your vehicle off, the SensorSafe system sounds a series of gentle tones reminding you that your baby is in the vehicle.

Download the SensorSafe application to manage your device, check manuals and set up your family alerts. Install it once and SensorSafe is always ready to alert you.

** Registered trademarks referenced in this manual are the property of their respective owners.

! WARNING

This product contains magnets. Before use, consult your family doctor about the compatibility of this product with pacemakers and similar devices.

Important Usage Information

- The SensorSafe system consists of two components: 1. The Chest Clip Transmitter and 2. The Receiver Plug. The system will not work unless both of these components are present in the vehicle with the Receiver installed in the vehicle's OBDII port (p. 67).



Chest Clip Transmitter



Receiver Plug

- This system works with the SensorSafe Application which can be downloaded from: The App Store® or Google Play™.**
- The SensorSafe Chest Clip is designed to go into a sleep mode after being clipped for 12 hours. Although 12-hour vehicle trips without stops are uncommon and not recommended, the Chest Clip must be opened and closed after 12 hours to reactivate the SensorSafe system.
- The Receiver Plug works ONLY with 2008 or newer vehicles purchased in the U.S. or Canada. If you would like to use the SensorSafe Chest Clip with a Hybrid or Electric vehicle, you will need to download the SensorSafe application from the App Store® or Google Play™.** Additional Receiver Plugs can be purchased for additional vehicles. If you have questions, please contact Evenflo's ParentLink at: 1-800-233-2229 (U.S.), and (Canada), to order a compatible Receiver Plug.

General Information about SensorSafe™ (cont.)

Battery Usage

- To preserve battery life, always store the SensorSafe Chest Clip in the un-clipped position.
- The Chest Clip ships with 1-button cell lithium battery installed that can be replaced.
- The SensorSafe battery should last for the life of this car seat, but is designed to alert you of a low battery. If your Chest Clip battery is getting low, the SensorSafe Receiver will make a "low battery" alarm when the Chest Clip is closed. This "low battery" alarm will sound different from the beeps you typically hear when activating your SensorSafe system. The SensorSafe Chest clips uses a Panasonic button battery CR2032. If you should have issues with SensorSafe hardware, please contact Evenflo's ParentLink at: 1-800-233-2229 (U.S.), and (Canada).

SensorSafe™ Technology

Questions? Comments?:

Visit us at: www.evenflo.com

Or call ParentLink at: 1-800-233-2229 (U.S.), and (Canada).

This device meets the requirements of SAE J3005.

FCC Certified:

Chest Clip Model: SOSR3, FCC ID: 2ABS2-SOSR3

Receiver Plug Model: SS2, FCC ID: 2ABS2-SS2

This device complies with Part 15 of the FCC Rules.

Operation is subject to the following two conditions:

- (1) This device may not cause harmful interference.
- (2) This device must accept any interference received, including interference that may cause undesired operation.

WARNING!

Changes or modifications not expressly approved by the party responsible for compliance could void the user's authority to operate the equipment.

NOTE: This equipment has been tested and found to comply with the limits for a Class B digital device, pursuant to Part 15 of the FCC Rules. These limits are designed to provide reasonable protection against harmful interference in a residential installation.

Using SensorSafe™

This equipment generates, uses, and can radiate radio frequency energy and, if not installed and used in accordance with the instructions, may cause harmful interference to radio communications. However, there is no guarantee that interference will not occur in a particular installation. If this equipment does cause harmful interference to radio or television reception, which can be determined by turning the equipment off and on, the user is encouraged to try to correct the interference by one or more of the following measures:

- Reorient or relocate the receiving antenna.
- Increase the separation between the equipment and receiver.
- Connect the equipment into an outlet on a circuit different from that to which the receiver is connected.
- Consult the dealer or an experienced radio/TV technician for help.

Chest Clip:

RF warning statement:

The device has been evaluated to meet general RF exposure requirement. The device can be used in portable exposure condition without restriction.

Receiver Plug:

FCC Radiation Exposure Statement:

This equipment complies with FCC radiation exposure limits set forth for an uncontrolled environment. This equipment should be installed and operated with minimum distance 20cm between the radiator & your body.

1. Install the SensorSafe Receiver.

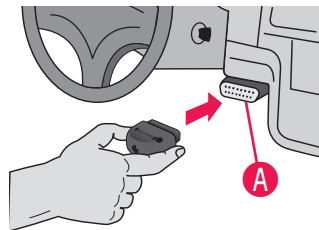

Locate the 16PIN OBDII port **A** in your vehicle. Refer to your vehicle owner's manual for location. Plug in the SensorSafe Receiver.

If unable to locate your vehicle manual, the SensorSafe Application may contain information regarding the location of the 16PIN OBDII port for your vehicle. Your SensorSafe Receiver will sound one prolonged tone when it first communicates with the vehicle network. In some vehicles this occurs immediately after installing the SensorSafe Receiver, in other vehicles the tone will not be heard until the vehicle has been started. This initialization signal only occurs one time after installation.

2. Power up the vehicle.

3. Cycle the SensorSafe Chest Clip.

Your SensorSafe Chest Clip is designed to “go to sleep” if clipped for more than 12 hours. To reset, or “wake up” the chest clip, unfasten then re-fasten it. When you do this, the blue LED will flash two times. TO PRESERVE BATTERY LIFE, ALWAYS STORE THE SENSORSAFE CHEST CLIP IN THE UNCLIPPED POSITION.

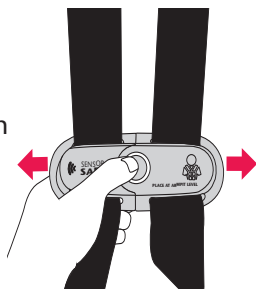

4. DRIVE THE VEHICLE.

The SensorSafe Receiver is designed to respond after the vehicle has been driven at 5 miles per hour or more.

5. PARK THE VEHICLE AND TURN OFF THE IGNITION.

Within 2 seconds of parking your vehicle and turning off the ignition you will hear the SensorSafe reminder, alerting you that your baby is in the vehicle. If you don't hear the reminder tone, test your SensorSafe by following steps 1-5 again. Contact Evenflo's ParentLink at: 1-800-233-2229 (U.S.), and (Canada) or online at: www.evenflo.com if the reminder tone again fails to sound.

Note: SensorSafe Receiver will also alarm if your child unclips the Chest Clip after the vehicle has been driven at 5 miles per hour or more, but only if the vehicle is on.

REPLACING THE SENSORSAFE CHEST CLIP BATTERY.

1. Loosen Harness by pressing Harness Release Button on the front of the Child Restraint and pulling forward on both Harness Straps.
2. Unbuckle Harness by pressing the button on the Crotch Buckle and pulling out both Buckle Tongues.
3. Open Chest Clip by pressing the Release Button and pulling the Chest Clip apart.

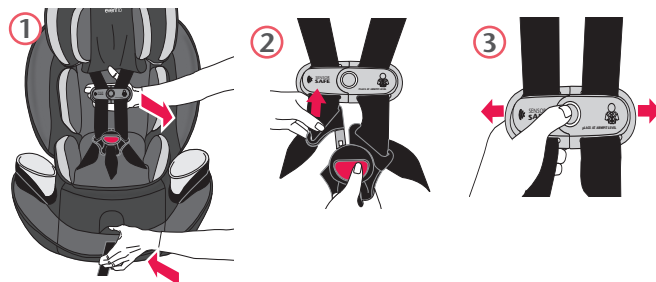

4. Turn the male side of the Chest Clip over and loosen screws with a small Phillips screwdriver. Remove the cover (a).
5. Remove Circuit Board (b) from Chest Clip. Remove Battery (c) from Circuit Board. Replace Battery with new Panasonic™ CR2032 Lithium button cell Battery, as shown.
6. Place the Circuit Board with the new Battery in the Chest Clip. Replace the Cover and tighten the screws. This completes the battery replacement process.

If you have questions, please contact Evenflo's ParentLink at: 1-800-233-2229 (U.S.), and (Canada) or online at: www.evenflo.com

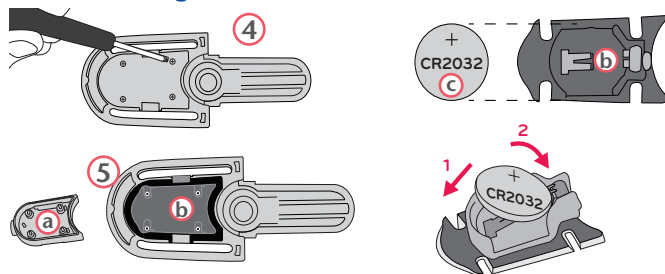

Registered trademarks referenced in this manual are the property of their respective owners.



Installing Child Restraint Rear-facing in Aircraft

The Federal Aviation Administration (FAA) recommends that you secure your child for air travel in an appropriate child restraint based on your child's weight and size. Turbulence can happen with little or no warning. When turbulence occurs, **the safest place for your child is in a properly installed child restraint, not in an adult's lap or on the aircraft seat with its seat belt.** Keeping your child in a child restraint during the flight will help ensure your family arrives safely at your destination. The FAA recommends that a child weighing:*

- more than 18 kg (40 lbs) use an aircraft seat belt;
- less than 9 kg (20 lbs) use a rear-facing child restraint; and
- from 9 to 18 kg (20 to 40 lbs) use a forward-facing child restraint. This restraint **CANNOT** be used in **booster mode** in aircraft.

* **Please note that these FAA recommendations may vary from those applicable to the use of your child restraint in a motor vehicle.**

IMPORTANT: Before installing the child restraint, make sure the **aircraft seat is in a fully upright position.**

1.

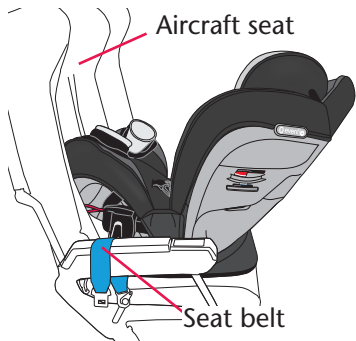

Unbuckle the aircraft seat belts and lay over the armrests, as shown. Adjust the child restraint to its **Recline Position 1, 2 or 3** (page 58), then place it on the aircraft seat **rear-facing**.

2.

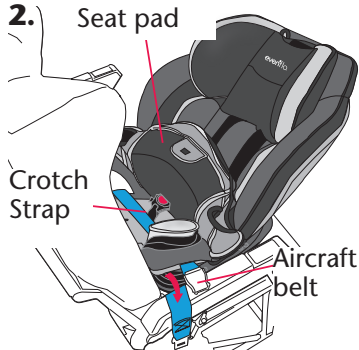

Pull the seat pad off the front of the child restraint. Route the aircraft seat belt through the rear-facing belt path opening on one side and continue through the belt path opening on the opposite side of the child restraint, as shown above.

IMPORTANT: Make sure the aircraft seat belt is **in front of the crotch strap**, as shown.

Installing Child Restraint Rear-facing in Aircraft (cont.)



3.

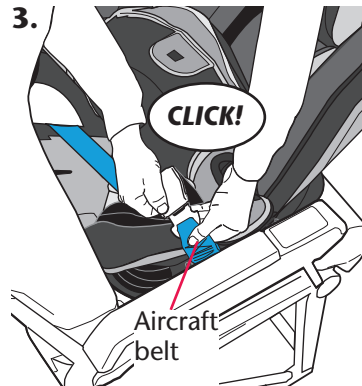

Fasten the aircraft seat belt.

4.

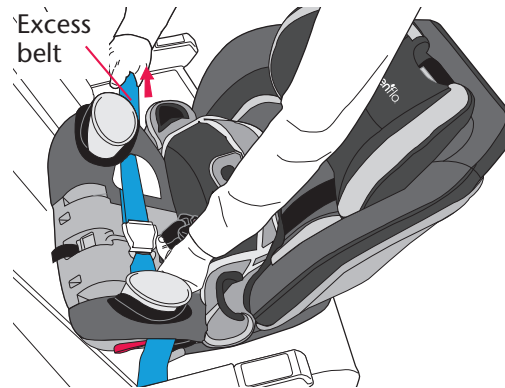

The aircraft seat belt must be as tight as possible. Route the excess seat belt strap back through the rear-facing belt path opening, as shown above. Using your full weight, push the child restraint firmly onto the aircraft seat while pulling on the excess seat belt strap to tighten.

Check your work. Reconnect the seat pad to the front of the child restraint. Try to move the child restraint in all directions. If you can move the restraint more than 2.5 cm (1 in.) side to side or front to back at the rear-facing belt path, the aircraft seat belt is not tight enough, and you **MUST** install again until the seat belt is tight.



Installing Child Restraint Forward-facing in Aircraft

TOC

1.



IMPORTANT: Before installing the child restraint, make sure the aircraft seat is in a fully upright position.

2.

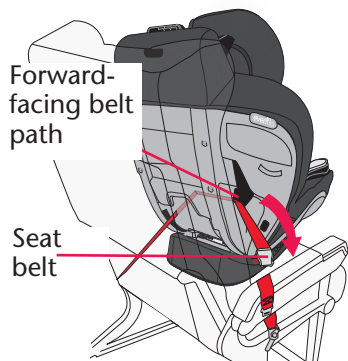

Adjust the child restraint to **Recline Position #5** (page 58), then place it on the aircraft seat **forward-facing**.

Route the aircraft seat belt through the forward-facing belt path opening in the back of the child restraint and continue through the belt path opening on the opposite side of the child restraint.

Note: Lift the restraint's back pad away for easier access.



3.

Fasten the aircraft seat belt.

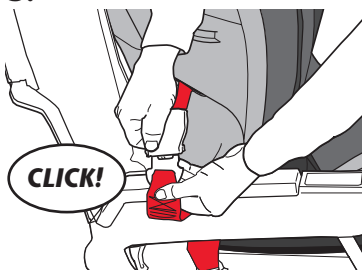

Installing Child Restraint Forward-facing in Aircraft



4.



The aircraft seat belt must be as tight as possible. Route the excess aircraft seat belt strap back through the forward-facing belt path opening, as shown. Using your full weight, push the child restraint firmly onto the aircraft seat while pulling on the excess seat belt strap to tighten.

Note: Because of the fixed length of aircraft seat belts, the belt buckle could be behind the child's back after tightening the belt. For your child's comfort, Evenflo recommends cushioning the child's back by placing a small pillow or folded-up blanket, or a folded-up jacket, over the belt buckle.

Check your work. Reconnect the seat pad to the child restraint. Try to move the child restraint in all directions. If you can move the restraint more than 2.5 cm (1 in.) side to side or front to back at the forward-facing belt path, the aircraft seat belt is not tight enough, and you **MUST** install again until the seat belt is tight.

Unfasten SensorSafe Chest Clip

As a final step, unfasten the chest clip (p. 62). In order to comply with the FAA regulation for Portable Electronic Devices (PED), the SensorSafe Chest Clip **MUST** be unfastened before take-off.

Note: After landing, fasten the SensorSafe Chest Clip before removing the Car Seat from the Aircraft seat.

Care and Cleaning

Removing the Seat Pad

1.  Raise headrest and unfasten the snaps on the fabric flap.

2.  Remove elastic straps from around the vehicle belt guides.

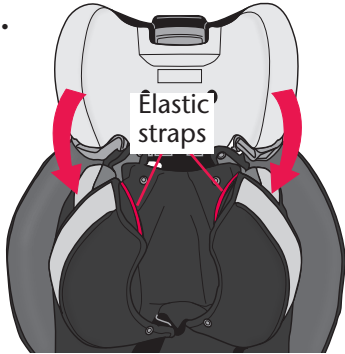
3.  Slide headrest pad over headrest and remove the elastic straps around the vehicle belt guides.

4.  Unfasten two snaps at bottom of Headrest Pad.

Removing the Seat Pad (cont.)

5.  Lift the head support flap up and unfasten the snap strap at bottom of head support pad.

6.  Pull the strap out of the opening in the head support board.

7. To remove headrest pad, lower backrest flap and slide pocket off headrest.

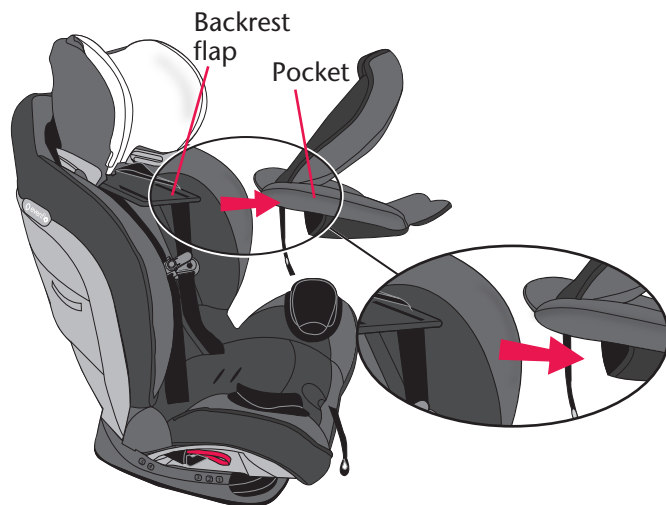

Removing the Seat Pad (cont.)

TOC
8.

Unfasten snap, on each side of seat pad.

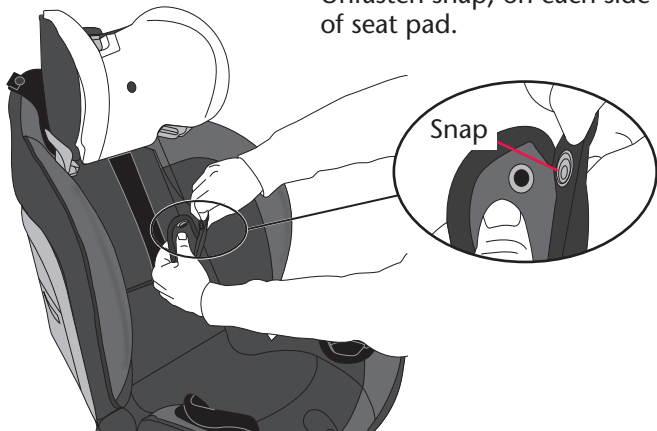

9.

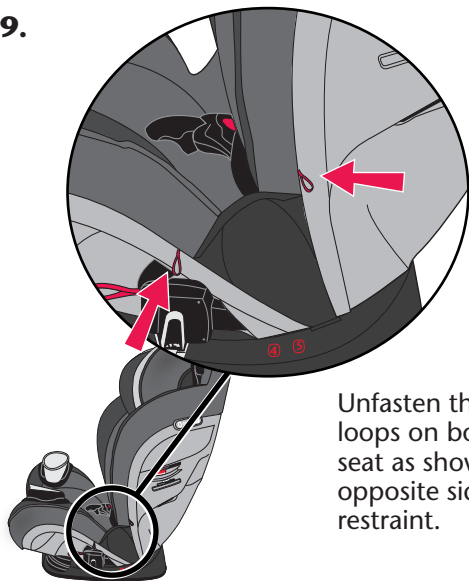

Unfasten the two elastic loops on both sides of the seat as shown. Repeat on opposite side of the child restraint.

Removing the Seat Pad (cont.)

10.

Push buckle through opening in seat pad as shown.

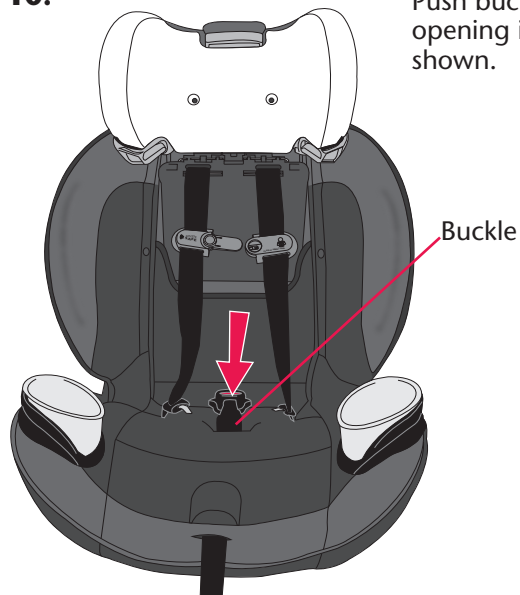

11.

Remove the seat pad from the edge of seat pad as shown. Repeat on the other side of the seat.

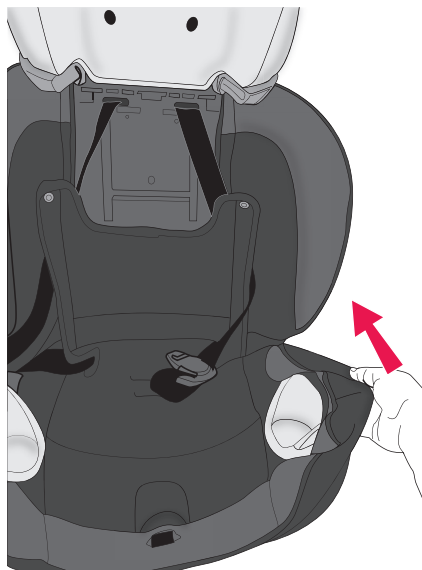

Removing the Seat Pad (cont.)

12.



Unclip tether from the tether anchor bar and push through slot in seat pad as shown.

13.

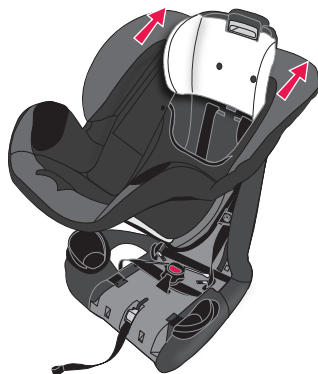

Remove seat pad from headrest, as shown.

Note: To re-attach Seat Pad, reverse this process.

Care and Cleaning

- **DO NOT** lubricate or immerse in water the LATCH connectors, the buckle, or any other part of this child restraint, unless rinsing is permitted, as stated on the back of the buckle for your restraint.
- Plastic and metal parts may be wiped clean with mild soap and water and dried with a soft cloth. Do not use abrasive cleaners or solvents.
- Take care not to damage any labels.
- The harness can be wiped clean with mild soap and water. Allow harness to air dry.
- Machine wash the seat pad separately in cold water, delicate cycle. Tumble dry 10 to 15 minutes on low heat.
- **NEVER** use child restraint without the seat pad.
- To protect the child restraint from damage caused by weather, rodents, and other elements common to garages, the outdoors, and other storage locations, remove the seat pad and thoroughly clean the restraint and pad prior to storage. Take care to clean in the areas where crumbs and other debris tend to accumulate.

Tip! To help protect the vehicle upholstery, place a towel beneath and behind the child restraint.

Storing Your Instructions / Model Info.

After thoroughly reading and following these instructions, store manual behind the headrest as shown below:

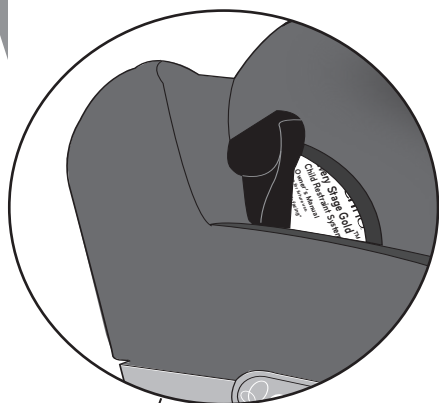

OWNERS MANUAL STORAGE -
Insert into pad behind headrest.

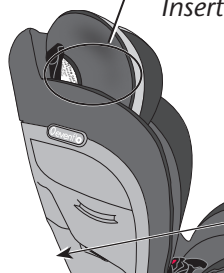

Manufactured in / Fabriqué en
(year-month-day)/(année-mois-jour)
Name / Nom
Model / Modèle
Made in / Fabriqué en
Expires on/Expire le

For future reference, record the model number of your child restraint AND the date of manufacture below.

Model Number: _____

Date of Manufacture: _____

Replacement Parts

Not available on all models. Styles may vary.

To order replacement parts you can order on-line at www.evenflogold.com or www.evenflogoldca.com, or contact Evenflo. When you contact us, please have the product model number and date of manufacture (found on the back of the child restraint).



Locking Clip:
Not included with
child restraint, see
page 13



Lower Anchor
Connector Assembly

Or



EasyClick™
Connector Assembly



Tether Extender



Cup Holder
Liner



Cup Holder



SensorSafe Chest Clip



SensorSafe Receiver



Harness Cover



Body Pillow



Head Pillow



Headrest Pad

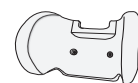

EPS Head Foam



Seat Pad



Anti-rebound Bar

Proper Disposal of this Child Restraint

When this child restraint reaches the expiration date found on the date of manufacture label, Evenflo encourages you to dispose of it properly. Most components of this child restraint are recyclable.

1. Remove all fabric and padding.
2. Remove all screws and disassemble the restraint.
3. Recycle all fabric, padding, plastic, foam and metal parts, if accepted by your local recycling center. Responsibly discard the rest.

If your local recycling center won't accept the padding, you may dispose of it in the landfill.

To prevent injury due to hidden damage, lost instructions, outdated technology, etc., discontinue use of this restraint after the expiration date on the label or if it has been involved in a crash.

TOC

Evenflo Gold Lifetime Warranty

Registration in the Evenflo Gold Lifetime Warranty means that for the life of this Gold product, Evenflo warrants to the original purchaser who registers online (“Registrant”) this Gold product against material irregularity. Evenflo’s sole obligation under this warranty shall be, at Evenflo’s option, to repair or replace any Gold product that is determined by Evenflo to be covered by this warranty. Repair or replacement as provided under this warranty is the exclusive remedy of the Registrant. Colors and fabrics change over time. Accordingly, we will replace your product or part with one of equal value. Proof of registration or proof of purchase in the form of a receipted invoice or bill of sale evidencing that the Gold product is eligible for this Gold Lifetime Warranty must be presented to obtain warranty service. This warranty is extended by Evenflo ONLY to the original Registrant and is not assignable or transferable to subsequent purchasers or end users of the Gold product. For warranty service, contact Evenflo’s ParentLink Consumer Resource Center at (800) 233-2229 or www.evenflogold.com and www.evenflogold.ca.

By simply registering your Evenflo Gold Stroller or Gold Car Seat online within 3 months of purchase, you, the Registrant, will have access to the following Gold Lifetime Warranty benefits:

- **Lifetime Warranty (*Car Seats)** - Through the expiration date of your Gold Car Seat, Evenflo warrants this Gold product to the Registrant against material irregularities.
- **Lifetime Warranty (*Strollers)** - Through the date when your child reaches the maximum weight of your Gold Stroller, Evenflo warrants the Gold Stroller frame to the Registrant against frame damage, including but not limited to, the breaking of welds and frame tube damage. Soft goods and all other components of your Gold Stroller shall be warranted for one year from the date of purchase.
- **Replacement Parts** - Evenflo will send out free replacement parts based on Gold Lifetime Warranty and subject to the exclusions listed below.
- **Premier Consumer Resource Center located in the USA--for product support, installation and assembly advice.**
- **Live Chat Support**
- **Motor Vehicle Accident Replacement** - Evenflo will replace your Gold Car Seat in the event of a motor vehicle accident.

***GOLD CAR SEAT WARRANTY INFORMATION:**

Your Evenflo Gold Car Seat is warranted to be free from any manufacturing irregularities for the life of the car seat under normal use conditions and according to the instruction manual. The expiration date for your Gold Car Seat is on the date of manufacture label.

This warranty is not transferable and extends only to the original purchaser who registered in the Evenflo Gold Lifetime Warranty.

If your Gold Car Seat is damaged due to the following, the Gold Lifetime Warranty does not apply:

- Misuse or poor maintenance. Please refer to this instruction manual for guidance;
- Sun intensity, sweat, detergents, damp storage or frequent washings;
- Airline or freight damage;
- Improper storage; or
- Second-hand use.

Evenflo reserves the right to make modifications to the terms and conditions of this Lifetime Warranty. Please review the current Lifetime Warranty applicable to your Gold product by accessing the online instruction manuals at www.evenflogold.com and www.evenflogold.ca.

ParentLink®

answers. advice. affirmation.™

USA, Canada: 1-800-233-2229, 8 AM to 5 PM E.T.