



Model No.
Serial No.

User Instructions

LYNX TRIPOD™

FALL-RESCUE™ WORK SYSTEM

WARNING

National standards and state, provincial and federal laws require the user to be trained before using this product. Use this manual as part of a user safety training program that is appropriate for the user's occupation. These instructions must be provided to users before use of the product and retained for ready reference by the user. The user must read, understand (or have explained), and heed all instructions, labels, markings and warnings supplied with this product and with those products intended for use in association with it. **FAILURE TO DO SO MAY RESULT IN SERIOUS INJURY OR DEATH.**

1.0 TRIPOD MODELS AND SPECIFICATIONS

TABLE 1. LYNX TRIPOD MODELS COVERED BY THESE INSTRUCTIONS

Model No.	Working Height		Weight		Skid Resistant Feet	Leg Base Chain	Anchorage Pins	Carrying Strap
	IN	M	LBS	KG				
10022050	91	2.3	43	19.5	YES	YES	YES	OPTIONAL
10022051	120	3.0	49	22.2	YES	YES	YES	OPTIONAL

1.1 SPECIFICATIONS - LYNX TRIPOD

- All Lynx Tripod Fall-Rescue Work Systems meet ANSI Z359.1 and applicable OSHA regulations when leg base chain is installed and properly adjusted.
- The Lynx Tripod head is zinc plated alloy steel, the Lynx Tripod legs are anodized, high-tensile, aluminum alloy.
- Capacity for personnel is 310 lbs (140 kg) including weight of the user plus clothing, tools and other user-borne objects.
- Capacity for material is 620 lbs (280 kg).



For More Information, call 1-800-MSA-2222 or Visit Our Website at www.MSAnet.com



MINE SAFETY APPLIANCES COMPANY
PITTSBURGH, PENNSYLVANIA, U.S.A. 15230

- Free fall distance (limit) must not exceed 6 ft (1.8 m) in accordance with OSHA and ANSI Z359.1. The Canadian Occupational Health & Safety Act of 1990 and ANSI A10.14 specify that free fall distance must not exceed 5 ft (1.5 m). The user must comply with applicable standards and regulations.
- When used as part of a personal fall arrest system, fall arresting forces must not exceed 1,800 lbf (8 kN).
- Minimum vertical static strength with legs fully extended, feet tread-down, on a hard, flat, lubricated surface;

Without leg base chain attached: 1000 lbs (4.5 kN),
 With leg base chain properly attached and adjusted: 5000 lbs (22.0kN).

10022050 10022051

- Size when compacted for transport or storage:
 - Length (L): 62 in (1.6 m) 89 in (2.3 m),
 - Outside Diameter (D) 15 in (0.4 m) 15 in (0.4 m).
- Interior distance (X) between feet when set up with:
 - Legs at maximum extension: 59 in (1.5 m) 72 in (1.8 m),
 - Legs at minimum extension: 37 in (0.9 m) 49 in (1.3 m).
- Overall height (Y) to top of head when set up with:
 - Legs at maximum extension: 96 in (2.4 m) 120 in (3.0 m),
 - Legs at minimum extension: 60 in (1.5 m) 84 in (2.1 m).
- Interior headroom height (H) when set up with:
 - Legs at maximum extension: 91 in (2.3 m) 115 in (2.9 m),
 - Legs at minimum extension: 55 in (1.4 m) 79 in (2.0 m).

Notes: Adding equipment at Lynx Tripod head reduces headroom.

See Figure 1 for dimension references.

FIGURE 1:

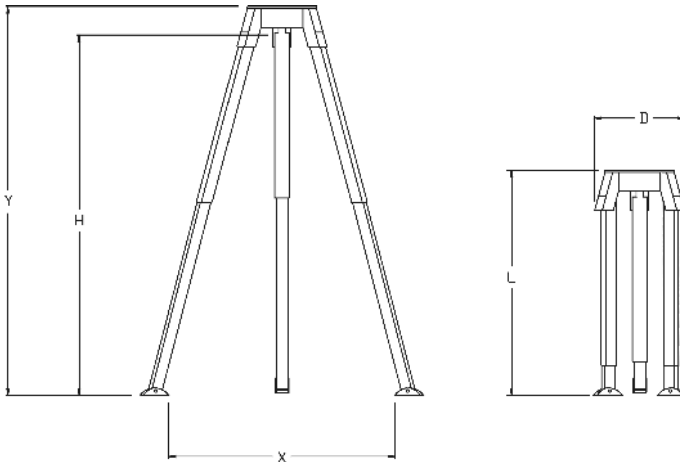

2.0 TRAINING

It is the responsibility of the purchaser of the Lynx Tripod to assure that Lynx Tripod users are made familiar with these user instructions and trained by a competent person. If the Lynx Tripod is to be used for confined space applications, the user must also be trained in accordance with the requirements of OSHA regulation 29 CFR 1910.146 and ANSI Z117.1. Training must be conducted without undue exposure of the trainee to hazards. The effectiveness of training should be periodically assessed (at least annually) and the need for more training or retraining determined. MSA offers training programs. Contact MSA for training information.

3.0 DESCRIPTION OF LYNX TRIPOD

The Lynx Tripod is an anchorage connector intended for both personnel- and material-moving applications. The figure shows a typical arrangement of the Lynx Tripod and compatible accessories used in assembling a fall arrest system. The intended purpose of each element of the Lynx Tripod is given in sections 4.1 through 4.4.

FIGURE 2

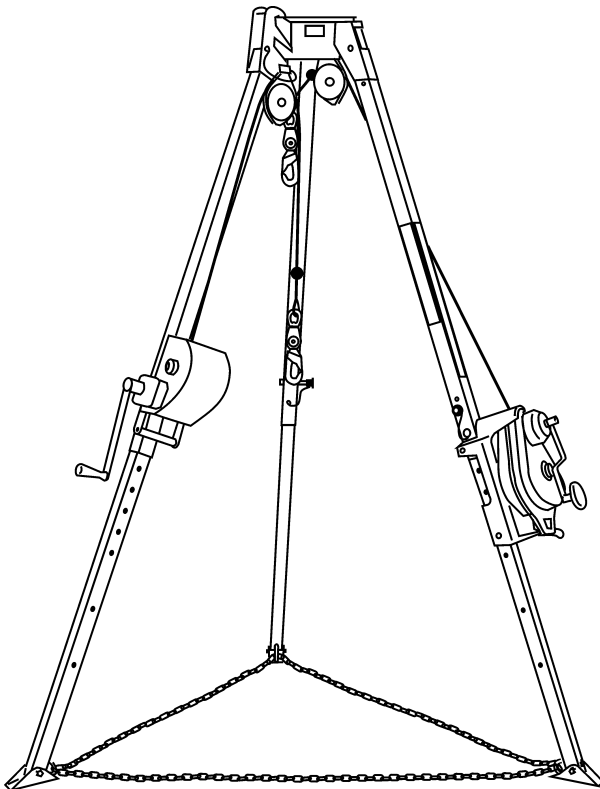

3.1 HEAD

3.1.1 POSITIVE LOCKING PIN (1):

There are two plates welded to the underside of the head near its center. A hole is drilled into each plate and the ball lock pin fits through these aligned holes. A thumb button on the end of the pin will release pressure on the locking ball at the opposite end of the pin. This allows disengagement and engagement of the Positive Locking Pin during assembly and removal of compatible accessories. The Positive Locking Pin is the smaller diameter of the two pins on the underside of the head. The plates and the Positive Locking Pin are used together to create a temporary intermediate anchorage connector for compatible accessories such as the MSA Split-Mount Pulley, P/N 506222. Refer to the separate User Instructions included with these products for installation and use of each of these optional components.

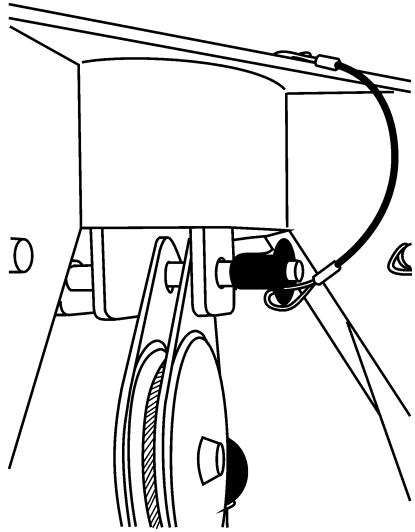

3.1.2 HITCH PIN (1):

There are two plates welded to the underside of the head. A hole is drilled into each plate and the hitch pin fits through these aligned holes. A cotter pin fits through a hole in the end of the hitch pin and must be removed to disengage the pin during assembly or removal of compatible accessories. The hair pin cotter must be in place on the hitch pin during use of the pin. The plates and the hitch pin are used together to create an intermediate anchorage connector for compatible accessories such as the MSA Boom-Mounted Lynx Hoist, MSA Dyna-Lock and MSA Lynx Rescuer.

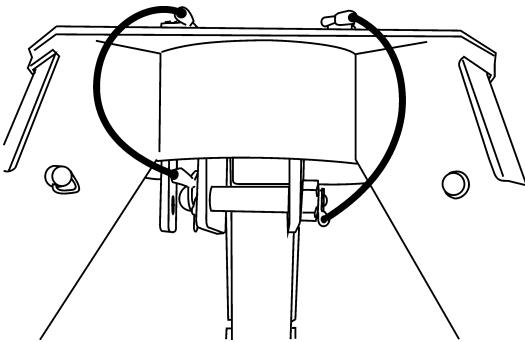

3.1.3 MOUNTING HARDWARE FOR OPTIONAL LYNX TRIPOD ACCESSORIES:

3.1.3.1

The MSA Side-Mounted Lynx Hoist personnel and materials hoist is mounted to the Lynx Tripod in conjunction with a side mount bracket, MSA P/N 506473.

3.1.3.2

The MSA wire rope model Dyna-Locks and Lynx Rescuers attach to the Lynx Tripod by means of leg mounting brackets. The Model 506216 Dyna-Lock/Lynx Rescuer mounting bracket adapts 22 m and 30 m units to the Lynx Tripod; the Model 506232 mounting bracket is used with the smaller 10 m and 16 m size units.

3.2 EXTENSION LEGS

3.2.1 POSITIVE LOCKING PINS, LEG (3):

There is one Positive Locking Pin in each extension leg. Each pin is inserted through the selected holes in the upper and lower legs when the desired leg extension is achieved.

3.2.2 CHAIN (1):

The leg base chain is necessary to maintain the position of the Lynx Tripod legs and to distribute the applied loads during system use. Lynx Tripod Models 10022050 and 10022051 have attachments at the base of each lower leg, through which the leg base chain is threaded. It is fully assembled when the screw-lock link is connected through the last link of one end of the chain and the closest link available after passing through all three attachments, at the other end of the chain.

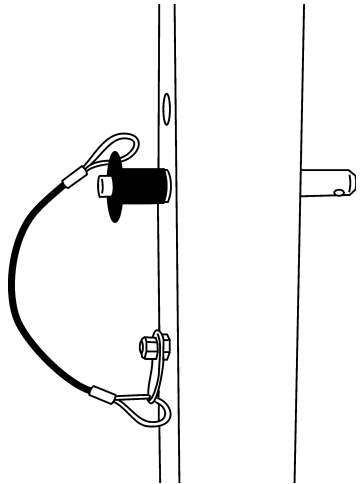

3.3 LYNX TRIPOD OPTIONAL ACCESSORIES

Refer to the individual User Instructions for each of the optional accessories for information regarding integration with the Lynx Tripod or other system components. Contact MSA for information on these optional accessories and their use in integrated systems.

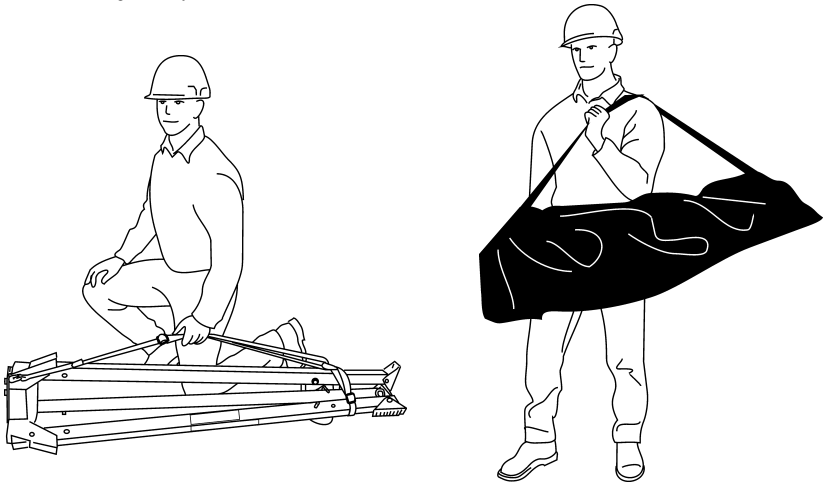

3.3.1 CARRYING STRAP:

The carrying strap allows transport of the folded Lynx Tripod. This strap should be removed when the Lynx Tripod is being used for any purpose other than transport and/or storage.

3.3.2 TOTE BAG:

The Nylon tote bag is used to protect the Lynx Tripod during transport and storage.

3.3.3 MSA DYNA-LOCK® SELF RETRACTING LANYARD (SRL):

Various models. See separate instructions P/N 620747, 622617, or 622711.

3.3.4 MSA LYNX RESCUER™ SRL WITH EMERGENCY RESCUER:

Various models. See separate instructions P/N 10011678.

3.3.5 MSA SPLIT-MOUNT PULLEY:

Model 506222.

3.3.6 MSA LYNX HOIST™ PERSONNEL/MATERIALS HOIST:

Various models. Side mounted or beam mounted configurations are compatible with Lynx Tripod. Lynx Hoist Side Mount Pulley Assembly, Model 506473 also required. See separate instructions P/N 10016732.

3.3.7 MSA DYNESCAPE™ DESCENT CONTROL DEVICES:

Model 506416, Manual Descender; or Model 506262, Automatic Descender. See separate instructions P/N 621883 or 622081, respectively.

3.3.8 MSA FALLBLOC™ FALL ARREST/EMERGENCY DESCENT SYSTEM:

Model 501500. See separate instructions P/N 621210.

3.3.9 MSA CARABINERS:

Models 506298, 506308, 506572. See separate instructions P/N 622543.

3.3.10 MSA SUSPENSION SEAT™:

Various models. See separate instructions P/N 622841.

**3.3.11 MSA BEAMGLIDE™ TROLLEY OVERHEAD BEAM
MOBILE ANCHORAGE CONNECTOR:**

Models 506252 and 506266. See separate instructions P/N 621595 or 621629, respectively.

4.0 LYNX TRIPOD SELECTION AND APPLICATIONS**4.1 PURPOSE OF LYNX TRIPOD:**

The Lynx Tripod is primarily an anchorage connector component of a personal fall arrest system. It may also be used for work positioning, ladder climbing, rescue, retrieval, evacuation, confined space entry/exit operations and material lifting and lowering, depending on which attachment elements are included. See section 4.4.

Use of the Lynx Tripod must comply with these User Instructions and, further, is subject to approval under the user's safety rules and regulations, safety director, supervisor, or a qualified safety engineer. Be certain the selection of the Lynx Tripod is suited for the intended use and work environment. If there is any conflict between these User Instructions and other directives or procedures of the user's organization, do not use the Lynx Tripod until such conflicts are resolved. Consult all local, state, and federal Occupational Health and Safety Administration (OSHA) requirements for personal safety equipment. Also refer to the latest revision of ANSI Z359.1 and ANSI A10.14 standards for more information on anchorages and associated system components. In Canada, refer to provincial and federal regulations and to CSA Z259.10, Z259.11 and Z259.1.

4.2 TYPICAL APPLICATIONS:

The figures in this section show configurations of optional accessories and typical applications of these systems.

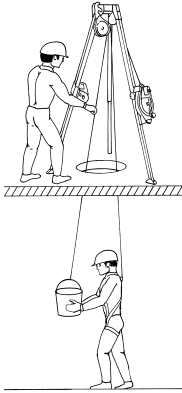

Fall-Rescue Work System (FRWS) using Side-Mount Lynx Hoist to lower material. Worker attached to Lynx Rescuer for fall arrest and emergency retrieval.

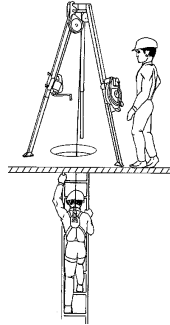

FRWS using Lynx Rescuer for fall arrest and emergency retrieval.

FRWS showing Side-Mount Lynx Hoist to raise and lower worker on suspension seat. Lynx Rescuer for fall arrest and emergency retrieval.

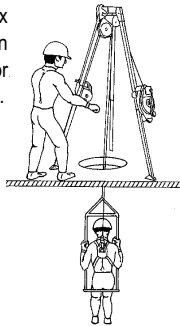

FRWS showing Lynx Rescuer and Y-retrieval Lanyard used for emergency retrieval.

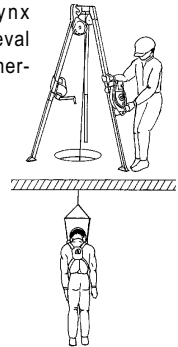

4.3 USAGE LIMITATIONS:

The following applications limitations must be considered and planned for before using the Lynx Tripod.

4.3.1 PHYSICAL LIMITATIONS:

The Lynx Tripod is designed for use by one person with a combined total weight no greater than 310 lbs (140 kg), including clothing, tools, and other user-borne objects; or in lifting or lowering materials with a combined total weight of no greater than 620 lbs (280 kg). Persons with muscular, skeletal, or other physical disorders should consult a physician before using a personal fall arrest system that includes a Lynx Tripod. Pregnant women and minors must never use these systems. Increasing age and lowered physical fitness may reduce a person's ability to withstand shock loads during fall arrest or prolonged suspension. Consult a physician if there is any question about physical ability to safely use this product to arrest a fall or suspend.



WARNING

Do not alter this equipment or intentionally misuse it.

4.3.2 HAZARDS:

- Acidic, alkaline, or other environments with harsh substances may damage the hardware elements of this Lynx Tripod. If working in a chemically aggressive environment, consult MSA to determine acceptable system components for your specific conditions.
- Do not use Lynx Tripod in environments with temperatures greater than 185° F (85° C).
- Do not expose Lynx Tripod to corrosive environments for prolonged periods.
- Use extreme caution when working near energized electrical sources. Maintain a safe working distance (preferably at least 10 feet (3 m)) from electrical hazards.
- When working near moving machinery parts (e.g. conveyors, rotating shafts, presses, etc.), make sure that there are no loose elements in any part of the system.

4.3.3 MAXIMUM ANCHORAGE SLOPE:

The surface (anchorage) where a Lynx Tripod is installed should be inclined by no more than 6 in (152 mm) over a distance of 10 ft (3 m). Any incline greater than this amount (2.8°) could allow the Lynx Tripod to slide or tip over.

4.3.4 WEAR AND DETERIORATION:

Any Lynx Tripod which shows signs of excessive wear, deterioration or malfunction must be removed from use and marked "UNUSABLE" until repaired. See sections 11 and 12 for detailed inspection procedures.

4.3.5 IMPACT FORCES:

Any Lynx Tripod which has been subjected to the forces of arresting a fall must be immediately removed from service and marked as "UNUSABLE" until submitted to, and released from, the Formal Inspection procedures described in section 12.

5.0 SYSTEM REQUIREMENTS

The Lynx Tripod is the anchorage connector component of multi-component systems. A suitable surface, such as level ground or an approved platform, is the anchorage to which the Lynx Tripod is connected. Without the other necessary components of a system, the anchorage connector serves no useful purpose. There are several different types of systems for use at heights and in confined spaces.

Lynx Tripod with Lynx Rescuer Self-Retracting Lanyard (SRL).

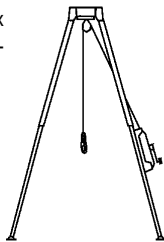

Lynx Tripod with Fallblocc Fall Arrest/Emergency Descent System.

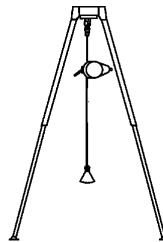

Lynx Tripod with Dyna-Lock Self-Retracting Lanyard.

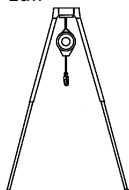

Twin Lynx Tripod with under-slung beam, BEAMGLIDE Trolley and Dyna-Lock Self-Retracting Lanyard.

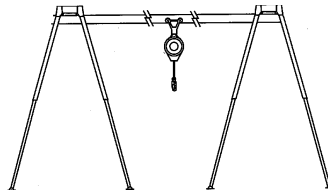

5.1 COMPATIBILITY OF SYSTEM PARTS

5.1.1 COMPATIBILITY OF COMPONENTS AND SUBSYSTEMS:

Lynx Tripod anchorage connectors are designed to be used with MSA approved components and connecting subsystems. Use of the Lynx Tripod with products made by others that are not approved in writing by MSA may adversely affect the functional compatibility between system parts and the safety and reliability of the complete system. Connecting subsystems must be suitable for use in the application (e.g. fall arrest, climbing protection, rescue or evacuation). MSA produces a complete line of connecting subsystems for each application. Contact MSA for further information. Refer to the manufacturer's instructions supplied with the component or connecting subsystem to determine suitability. For fall arrest applications using the Lynx Tripod, the maximum fall arrest force must not exceed 1,800 lbf (8 kN). Contact MSA with any questions regarding compatibility of equipment used with the Lynx Tripod.

5.1.2 COMPATIBILITY OF CONNECTORS:

Connectors, such as D-rings, snaphooks, and carabiners, must be rated at 5,000 lbf (22 kN) minimum breaking strength. MSA connectors meet this requirement. Connecting hardware must be compatible in size, shape, and strength. Non-compatible connectors may accidentally disengage ("rollout"). Always verify that the connecting snaphook or carabiner and the D-ring on a full body harness or Lynx Tripod anchorage connector are compatible. Use only self-closing, self-locking snaphooks and carabiners (as defined and required by ANSI Z359.1) with the Lynx Tripod.

5.1.3 ANCHORAGES AND ANCHORAGE CONNECTORS:

Anchorage for personal fall arrest systems must have a strength capable of supporting a static load, applied in directions permitted by the system, of at least: (a) 3,600 lbf (16 kN) when certification exists, or (b) 5,000 lbf (22.2 kN) in the absence of certification. See ANSI Z359.1 for definition of certification. The Lynx Tripod is designed for connection by a single personal fall arrest system. See section 7.1 for considerations in selecting an appropriate anchorage for use with the Lynx Tripod anchorage connector. See ANSI Z359.1, section 7.2.3. This requirement is consistent with OSHA requirements under 20 CFR 1910, Subpart F, Section 1910.66, Appendix C. In addition, it is recommended that the user of personal fall arrest systems refer to ANSI Z359.1, Section 7, for important considerations in equipment selection, rigging, use, and training. Contact MSA for information regarding custom design applications for the Lynx Tripod anchorage connector.

6.0 PLANNING THE USE OF SYSTEMS

Do not use the Lynx Tripod unless a qualified person has inspected the workplace and determined that identified hazards can neither be eliminated nor exposures to them prevented.

Prior to selecting a Lynx Tripod or other personal protective equipment, the user must make a workplace assessment of hazards and conditions where the equipment is required. Such assessment must, at a minimum, identify the presence of:

- Hot objects
- Sparks
- Flames
- Unstable/uneven surfaces
- Slippery surfaces
- Chemicals
- Electrical hazards
- Environmental contaminants
- Heat-producing operations
- Confined space hazards
- Abrasive surfaces
- Moving equipment
- Moving materials
- Sharp objects
- Climatic factors
- Weather factors
- Unguarded openings

Foreseeable changes in any of these conditions, taken individually or collectively, must be identified, evaluated and controlled. The materials and construction of the Lynx Tripod and associated equipment must be considered in the selection process such that these workplace conditions are suitably addressed and responded to. The equipment must match the work situation and workplace environmental factors.

The workplace assessment must identify all paths of intended user movement and all hazards along such paths. The user must identify the required range of mobility in each hazard zone and note the location and distance to all obstructions in potential fall paths. Lateral obstructions which could be contacted in a pendular fall arrest must be noted. An assembly connecting a harness to the anchorage must be selected which will satisfactorily limit total fall distance and allow for dynamic elongation and activation distance of the assembly. If the Lynx Tripod is to be used for confined space entry operations, the workplace assessment must comply with the requirements of OSHA regulation 29 CFR 1910.146 and ANSI Z117.1.

6.1.1. LEG BASE CLEARANCE (INSIDE AND OUTSIDE)

Clearance between the position of the Lynx Tripod feet when erected and in working position and the access through which the worker will be lowered shall be such that none of the Lynx Tripod legs will be positioned above the access or be allowed to fall into the opening. Clearance between the working position of each of the Lynx Tripod feet and the outside of the anchorage shall be a minimum of 3 ft (0.9 m) and shall allow unrestricted movement of support personnel above during erection, use and compaction.

CAUTION

Keep work area free from obstructions, trip hazards and spills which could impair the safe operation of the Fall-Rescue Work System.

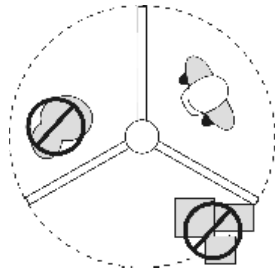
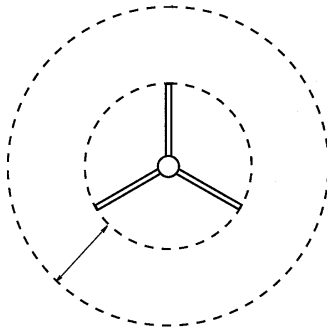

6.1.2 EXTERIOR CLEARANCE AND INTERIOR HEADROOM:

There must be sufficient exterior clearance above the anchorage to fully erect the Lynx Tripod. This clearance, for each model, is given in section 1.1. upon the system components (optional accessories) that may be attached to the mounting pins of the Lynx Tripod head. Refer to the User Instructions supplied with each system component to determine the effect on overhead clearance due to such installation.

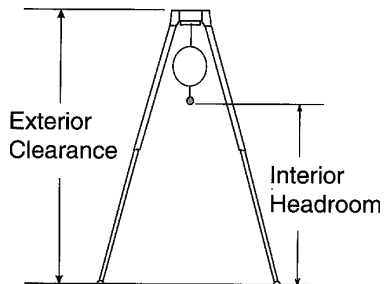

6.1.3 REQUIREMENTS FOR ADDITIONAL ANCHORAGES AND ANCHORAGE CONNECTORS:

The Lynx Tripod is intended for use by a single person. Other personnel working in this immediate area as part of a support team will require separate and independent safety systems depending on their purpose and work function. Each person working in a given area must have systems provided to suit the hazards that may be present. This determination must be made by a qualified safety engineer in accordance with sections 3 and 6 of these instructions, or corresponding sections of User Instructions from any optional components.

6.2 FREE FALL DISTANCE, TOTAL FALL DISTANCE, AND SYSTEM ELONGATION:

Personal fall arrest systems must be selected and rigged to ensure that potential free fall distances will never exceed 6 ft (1.8 m) as required by OSHA and ANSI Z359.1. [In Canada, free fall distance is limited to 5 ft (1.5 m) by regulation. ANSI A10.14 also restricts free fall distance to 5 ft (1.5 m)]. See separate instructions for connecting subsystems to determine the deceleration distance and dynamic elongation which must be allowed for in the space of potential fall paths. Total fall distance is the sum of free fall distance and deceleration distance. Dynamic elongation of the system (temporary elastic stretch of connecting components and subsystems) must be added to total fall distance and clearance allowed.

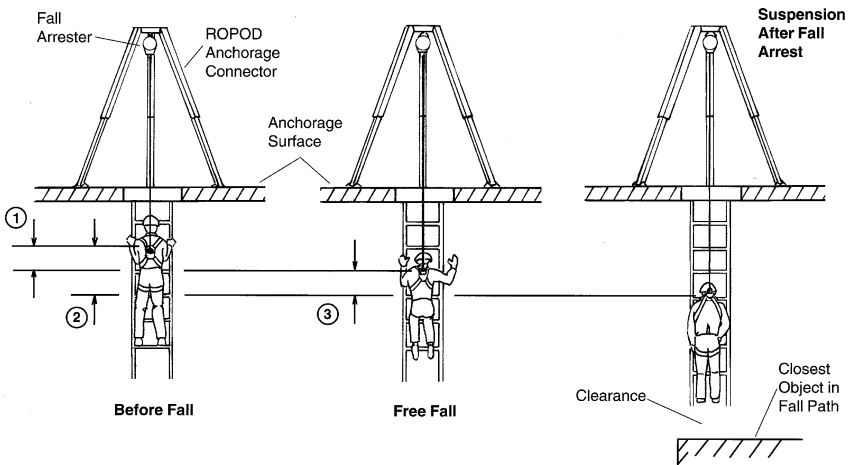

- 1 Free fall distance. Limited to 6 ft (1.8 m) by OSHA and ANSI Z359.1. Limited to 5 ft (1.5 m) by ANSI A10.14 and Canadian regulations.
- 2 Total fall distance. The sum of the free fall distance and deceleration distance.
- 3 Deceleration distance. Must not exceed 3.5 ft (1.1 m).

6.3 CLEAR SPACE IN FALL PATH:

Make certain that enough clearance is available in all potential fall paths to prevent striking an object. The amount of clearance needed depends upon the type of connecting subsystem used, and the location of the anchorage or anchorage connector. Consult the manufacturer's instructions for the particular connecting subsystem or component for clearance needed.

6.4 RESCUE AND EVACUATION:

The user must have a rescue plan and the means at hand to implement it. The plan must take into account the equipment and special training necessary to effect prompt rescue under all foreseeable conditions. If the rescue is from a confined space, the provisions of OSHA regulation 1910.146 and ANSI Z117.1 must be taken into account. Although a rescue plan and the means to implement it must always be in place, it is a good idea to provide means for user evacuation without assistance of others. This will usually reduce the time to get to a safe place and reduce or prevent the risk to rescuers. If the Lynx Tripod is to be included as part of rescue or evacuation systems, the optional system components required (see section 4), the time required to erect the Lynx Tripod and attach any optional components, and the anchorage requirements (see section 7.1) should be considered when planning these systems.

7.0 USAGE

7.1 LYNX TRIPOD INSPECTION BEFORE EACH USE:

Inspect the Lynx Tripod to verify that it is in serviceable condition. Examine every inch of the Lynx Tripod for severe wear, missing or broken elements, corrosion, or other damage. See section 11 for inspection details. Do not use the Lynx Tripod if inspection reveals an unsafe condition.

7.2 ERECTING AND COMPACTING LYNX TRIPOD:

CAUTION

Do not open the confined space access cover before completing installation of the Lynx Tripod and all other system components.

7.2.1 ERECTING AND ADJUSTING THE ROPOD:

Step 1:

Tilt the ROPOD into an upright, feet-down position.

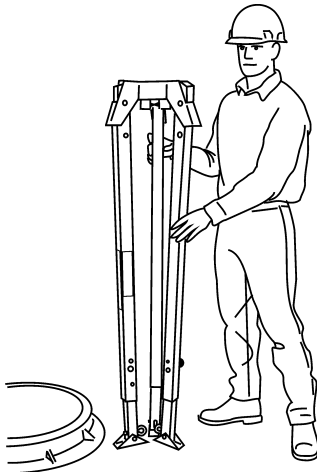

Step 2:

Hinge each leg, one at a time, into the outward and locked position. You will note that each leg automatically snaps upwardly when the hinge locks. Check to be certain of hinge locking.

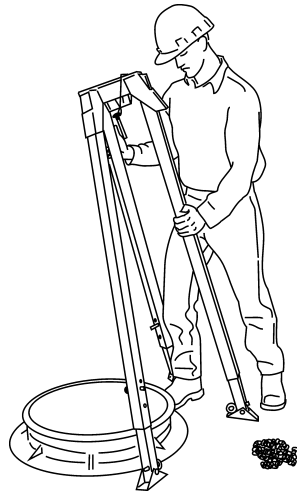

CAUTION

Potential pinch point. DO NOT touch tripod leg within six (6) inches of the tripod head.

Step 3:

Position the feet about the hatch cover in accordance with work area geometry and surface conditions.

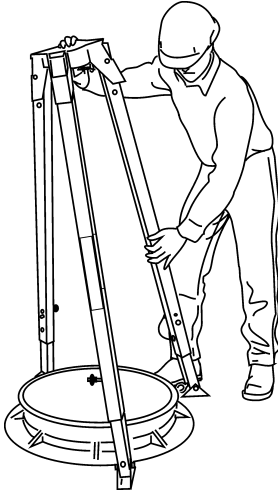

Step 4:

Optional components such as the Split-Mount Pulley or the Dynevac with leg-mount bracket should be assembled to the Lynx Tripod at this time. Follow the appropriate user instructions for each optional component that is to be connected to the Lynx Tripod.

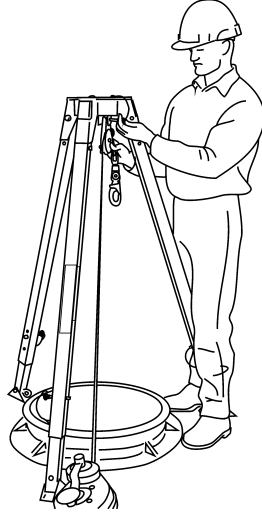

Step 5:

Raise the Lynx Tripod one leg at a time by pulling the positive-locking pin (attached to the upper leg section), incrementally sliding out the lower leg section, and repinning. Repeat for each leg until the Lynx Tripod head is at the desired height. Each leg may be extended to different lengths to accommodate variations in surface elevation. The Lynx Tripod head should be horizontal when installation is complete. Be careful not to extend each leg too far in each increment so as to cause the Lynx Tripod to topple.

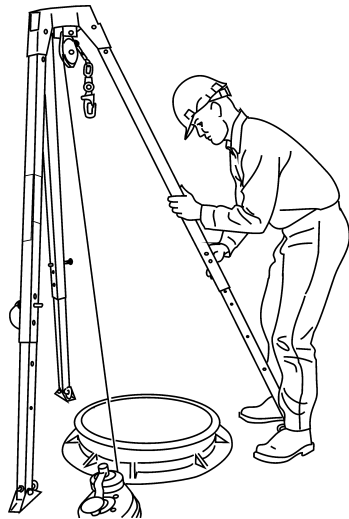

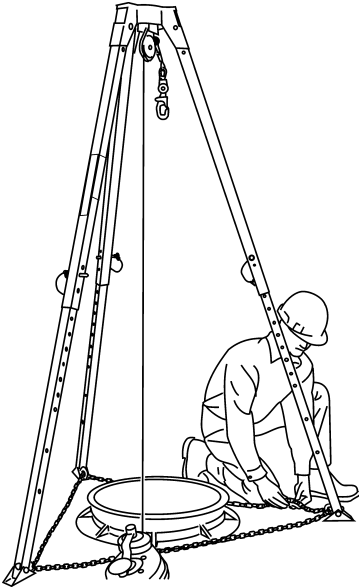
**Step 6:**

Once at the proper height, check to be sure the Lynx Tripod is stabilized and plumb. Feed the stabilizing chain through the chain connector at the base of the Lynx Tripod legs and continue to adjust the legs to the proper height. Some final leg length adjustment may be necessary to properly distribute the load to each leg. Check all leg pins to assure secure fastening and set the feet in either the tread-down or spike-down position (according to anchorage surface conditions). Tighten the chain through all connectors, bring the last link of one end of the chain and the closest link available at the other end of the chain and fasten using

When all equipment is in place on the Lynx Tripod, make a last check for plumbness, foot traction and stability. Make final adjustments. On uneven terrain it may be necessary for the "downhill" leg(s) to be extended farther to stabilize the Lynx Tripod by equalizing the weight borne by each leg. On uneven terrain it is better to have optional equipment such as the Lynx Rescuer or Lynx Hoist mounted on the "uphill" legs for greater stability. The Lynx Tripod head should be horizontal when installation is complete.

Now remove the hatch and manhole cover. For a descriptive brochure on MSA implements to assist in manhole cover removal, contact MSA.

7.2.2 COMPACTING THE LYNX TRIPOD:

To compact the Lynx Tripod for transport or storage, reverse the setup procedure. To disengage the leg hinge locks, pull down on the leg and hinge it inward. Attach Lynx Tripod legs together securely with lower strap as shown. After use, return the Lynx Tripod to the proper person and place for cleaning and storage as described in section 9.

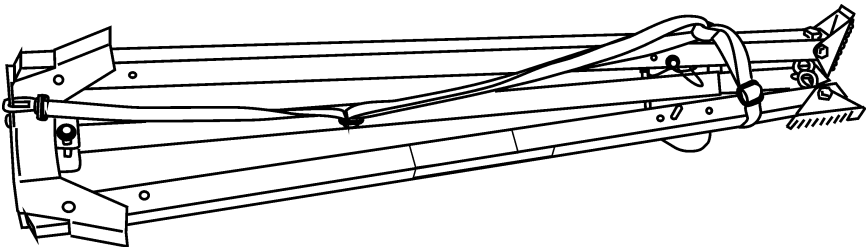
**7.3 MAKING PROPER CONNECTIONS****7.3.1 USE OF ATTACHMENT PINS:**

The Positive Locking Pin is used to mount the optional MSA Split-Mount Pulley P/N 506222, and may also be used to connect directly with a MSA Carabiner. The Split-Mount Pulley is designed to work in conjunction with a Lynx Rescuer, where the cable of the Lynx Rescuer would pass through the Side-Mount Pulley and descend into the center of the work access. The MSA Carabiner may be used as an intermediate connector for system

components, such as the MSA Fallbloc Lifeline. The Hitch Pin is used to mount the optional Lynx Boom Hoist. See section 7.5. Contact MSA for information about connection of optional components to the Lynx Tripod or refer to the separate User Instructions provided with each component.

7.3.2 MAKING CONNECTIONS:

When using a snaphook to connect to an anchorage or when coupling components of the system together, be certain accidental disengagement (“rollout”) cannot occur. Rollout is possible when interference between a snaphook and the mating connector causes the snaphook’s gate or keeper to accidentally open and release. Rollout occurs when a snaphook is snapped into an undersized ring such as an eye bolt or other non-compatibly shaped connector. Only self-closing, self-locking snaphooks and carabiners should be used to reduce the possibility of rollout when making connections. Do not use snaphooks or connectors that will not completely close over the attachment object. Do not make knots in a lanyard. Do not hook the lanyard back onto itself. Snaphooks and carabiners must not be connected to each other. Do not attach two snaphooks into one D-ring. Do not attach a snaphook directly to a horizontal lifeline. Always follow the manufacturer’s instructions supplied with each system component. Refer to Section 2 of these instructions.

7.4 INSTALLATION OF SIDE-MOUNT HOIST & LYNX RESCUER TO LYNX TRIPOD

To install the side-mount hoist, follow the instructions below and refer to Figure 11.

- Step 1: In accordance with the tripod instructions, raise the tripod only to a height where the tripod head is easily reachable by the installer.
- Step 2: Mount the pulley bracket P/N 506473 (A) to the top of the tripod leg (B) to the **LEFT** of the Lynx Rescuer/ Dyna-Lock mounting leg with green label. Pin the bracket in place with the ball lock pin (C).
- Step 3: Place the hoist to the right side (when facing the leg) of the leg to which the pulley bracket is mounted, and extract approximately 9 ft (2.7 m) of line (D). Attach the pulley (E) to the pulley bracket (A) with the clevis pin (F). Secure the clevis pin with the hairpin cotter (G). Note: The hoist snaphook must hang to the interior of the tripod.
- Step 4: If using a fall arrester that’s leg-mounted to the tripod (ie: the Lynx Rescuer, Dynevac II, or Dyna-Lock retractable lifeline) it is attached to the leg with the green labels. Lay the fall arrester on the ground next to this leg. Extract sufficient fall arrester line and reeve the line over the split-mount pulley, P/N 506222. Pin the pulley in the head of the tripod using the attached ball lock pin. See step 4 of section 7.2.1.
- Step 5: Raise the tripod to the desired working height.
- Step 6: Insert the tripod leg pin (H) for the leg to which the hoist will be mounted *partially* through the tripod leg, starting from the left side of the outside face of the leg. See Figure 11.

FIGURE 11: INSTALLATION OF PULLEY BRACKET AND PULLEY AT TRIPOD HEAD

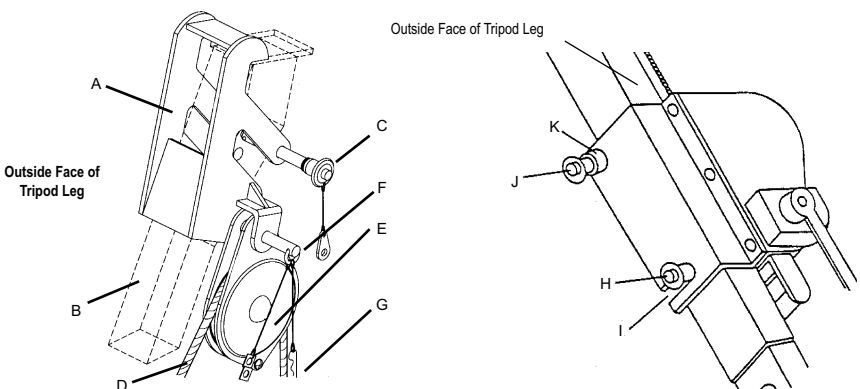

⚠ CAUTION

Be sure to insert the tripod leg pin (H) completely through the tripod leg and hoist housing.

- Step 7: Insert the ball lock pin (J) through the holes (K) at the top of the hoist mounting bracket and behind the tripod leg.
- Step 8: If using a leg-mounted fall arrester, mount that product to the tripod leg with the green instruction label using the mounting bracket, P/N 506216 & 506232. Pin the bottom pin of the bracket through one of the holes in the lower leg of the tripod. The upper pin of the bracket pins on the inside face of the Tripod leg. For most applications, it is ergonomically preferable to mount the fall arrester at waist level.
- Step 9: Install the tripod leg base chain and check to be sure the tripod is stabilized and plumb. Some final leg length adjustment may be necessary to properly distribute the load to each leg. Check all leg pins to ensure secure fastening. Set the feet in either tread-down or spike-down position, according to the condition of the surface on which the tripod rests.
- Step 10: With all equipment now in place on the tripod, make final adjustments and last check for plumbness, foot traction, leg base chain tautness and stability. On uneven terrain, it may be necessary for the “downhill” leg(s) to be extended to stabilize the tripod by equalizing the weight borne by each leg. On uneven terrain it’s better to have the Lynx Rescuer and Lynx Hoist mounted on the “uphill” leg(s) for greater stability.

7.5 INSTALLATION OF BOOM-MOUNT HOIST TO TRIPOD

To install the boom-mount hoist to the tripod, read the following instructions and refer to Figure 12.

FIGURE 12

INSTALLATION OF ANCHORAGE HOOK AT ROPOD HEAD

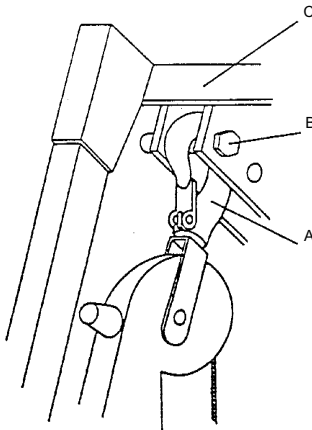

INSTALLATION OF BOOM-MOUNT HOIST ON ROPOD LEG

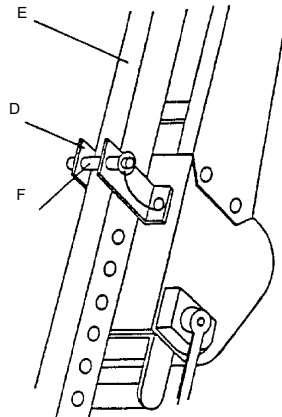

- Step 1: If using a leg-mounted fall arrester such as the Lynx Rescuer or Dyna-Lock retractable lifeline, first install the fall arrester on the tripod according to the instructions and labels accompanying that product. Then raise the tripod to the desired working height before installing the hoist.
- Step 2: Snap the extension frame anchorage hook (A) around the large pin (B) at the tripod head (C).
- Step 3: Position the hoist's leg mounting bracket (D) around the tripod leg (E). If using the boom hoist with a leg-mounted fall arrester, mount the hoist on the leg to the left of the fall arrester. Pin in place with the ball lock pin (F).
- Step 4: Complete installation of the tripod in accordance with the instructions accompanying the product.

7.6 INSTALLATION OF LYNX RESCUER TO LYNX TRIPOD

The LYNX RESCUER may be used in many different system arrangements for fall arrest and emergency retrieval. Most of these systems require special engineering design, testing, controlled installation and supervised training and use in order to be safe. MSA has developed a system offered as part of its product line which does not require special engineering to be put into use. This is the FRWS (Fall-Rescue Work System) utilizing the Lynx Tripod (portable tripod). This system, nevertheless, must be cautiously applied under the supervision of a competent person.

The Lynx Tripod portable anchorage connector system facilitates access to confined spaces with topside openings such as manholes. The Lynx Hoist provides personnel and materials lifting and lowering while the Lynx Rescuer provides backup fall arrest, which is further backed-up by the Lynx Rescuer's built-in emergency rescue mechanism. Use of leg mounting of both the Lynx Rescuer and Lynx Hoist lowers the system's center of gravity by adding their weights to lower sections of the Lynx Tripod, which reduces the Lynx Tripod toppling hazard. Leg mounting also permits topside workers and rescuers to operate the Lynx Tripod and Lynx Hoist at waist level and away from the hatch opening.

In the complete FRWS, a worker in a full body harness can be attached to the Lynx Rescuer for fall protection. The Lynx Rescuer is mounted on a Lynx Tripod leg and the Lynx Rescuer working line is reeved over the Split-Mount pulley attached at the Lynx Tripod head. The user can then be seated and strapped into a suspension seat which is attached to the Lynx Hoist snap hook. Lynx Hoist is mounted on another Lynx Tripod leg and its extension tube with hook end is connected at the Lynx Tripod head. With Lynx Tripod positioned over a hatch opening, the worker seated in the suspension seat can be lowered by the Lynx Hoist. See separate User Instructions for information regarding the Lynx Hoist.

If the suspended worker intentionally leaves the suspension seat at the floor of the confined space, he will remain connected to the Lynx Rescuer at the fall arrest D-ring on the harness. The Lynx Hoist is therefore free to lower and lift materials and equipment to and from the downside worker's elevation. When not in use for materials handling and personnel transport, the Lynx Hoist is available for rescue of downside workers (one at a time). If the downside worker falls (or is overcome) while connected to the Lynx Rescuer, his fall is arrested and the Lynx Rescuer's emergency rescue mechanism can be activated topside for retrieval.

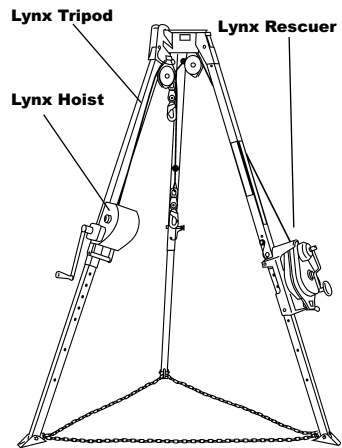

Installation with Lynx Tripod

8.0 CARE MAINTENANCE AND STORAGE

8.1 CLEANING INSTRUCTIONS:

Clean the Lynx Tripod with a solution of water and mild laundry detergent. Dry hardware with a clean cloth. Do not speed drying with heat. Excessive accumulation of dirt, paint, or other foreign matter may prevent proper function of the Lynx Tripod and, in severe cases, weaken the material and joints. Questions concerning Lynx Tripod conditions and cleaning should be directed to MSA.

8.2 MAINTENANCE AND SERVICE:

Equipment which is damaged or in need of maintenance must be tagged as "UNUSABLE" and removed from service. Corrective maintenance (other than cleaning) and repair, such as replacement of elements, must be performed by the MSA factory. Do not attempt field repairs.

8.3 STORAGE:

Store the Lynx Tripod in a cool, dry and clean place. Avoid areas where heat, moisture, oil, and chemicals or their vapors or other degrading elements may be present. Equipment which is damaged or in need of maintenance should not be stored in the same area as usable equipment. Heavily soiled, wet, or otherwise contaminated equipment should be properly maintained (e.g. dried and cleaned) prior to storage. Prior to using equipment which has been stored for long periods of time, a Formal Inspection should be performed by a competent person. See section 12.

9.0 LABELS AND MARKINGS

9.1

The following labels must be present, legible and securely attached to the Lynx Tripod. The Formal Inspection Grid must be punched with a date (month/year) within the last six months. If not, remove the Lynx Tripod from use and mark it as "UNUSABLE" until a Formal Inspection is performed in accordance with section 12. See section 4 for location of labels.

MSA ROSE



PART NUMBER	
10022050	10022051
8 ft	10 ft

⚠ ADVERTENCIA

Se conformer impérativement aux instructions du fabricant jointes à ce produit au moment de l'expédition. Pour obtenir des manuels d'utilisation supplémentaires, contacter Rose Manufacturing.

⚠ ADVERTISSEMENT

Siga las instrucciones del fabricante que se adjuntan a este producto. Si necesitara más manuales de instrucción, comuníquese con Rose Manufacturing.

Specifications

- Maximum working load:
 - 310 lbs (141 kg) personnel
 - 620 lbs (282 kg) materials
- Vertical static strength:
 - Chain not attached:
 - 1000 lbs (4.45 kN)
 - Chain attached:

Chain not attached:

- 1000 lbs (4.45 kN)
- Chain attached:
 - 5000 lbs (22 kN)

8 ft Tripod:

- Weight: 43 lbs (19.5 kg)
- Maximum height:
 - Interior: 91 in. (231 cm)
 - Overall: 96 in. (244 cm)

10 ft Tripod:

- Weight: 49 lbs (22 kg)
- Maximum height:
 - Interior: 115 in. (292 cm)
 - Overall: 120 in. (305 cm)

⚠ CAUTION

INSPECTION

Inspect for excessive wear, damage, missing or altered parts. Remove from use if any defective or altered condition is detected.

- User must inspect before each use.
- Separate competent person must formally inspect at least every 12 months.
- Punch inspection grid if product passes formal inspection.

FORMAL INSPECTION GRID

YR	J	F	M	A	M	J	J	A	S	O	N	D
1 st												
2 nd												
3 rd												
4 th												
5 th												

PUNCH GRID MONTH OF FIRST USE

P/N 10021714

MSA ROSE



ROSE PORTABLE TRIPOD
 A component of Fall Rescue™
 Work System

INSTRUCTIONS

Read and strictly follow separate detailed instructions in User instructions. Information below is a summary and not a substitute for User Instructions.

TO SET UP

Place upright, feet down. Hinge legs out one at a time. Legs must lock. Place feet about covered surface opening. Attach pulley to head of Tripod after reeving cable of Rescuer™, Dyna-Lock®. Attach Lynx Hoist™ Side Mount bracket to head of Tripod. Reeve cable of Lynx Hoist™ over pulley and attach to bracket. Extend legs one at a time in short increments to prevent Tripod instability. Pins must pass through both sides of leg and lock. According to surface conditions, set feet in tread-down or spike-down position to get best traction. Be sure Tripod is stable. Install leg-mounted equipment (e.g. Lynx Rescuer™, Dyne-Lock®, Lynx Hoist™) using proper brackets. Install leg base chain.

WHEN IN USE

Use Tripod only with manufacturer approved equipment and as instructed.

NEVER:

- 1) Overload.
- 2) Swing suspended load.
- 3) Move suspended load.
- 4) Leave unattended with suspended load, with

- 4) Leave unattended with suspended load, with workers below or with surface cover removed.
- 5) Adjust legs when load is on line.

ALWAYS:

- 1) Place safety barriers and warning signs about work area.
- 2) Have rescuer at Tripod in communication with persons below .
- 3) Have a rescue plan.
- 4) Test environment in confined space before entry.
- 5) Use correct life-support and safety equipment.

TO TAKE DOWN

Remove workers from below surface. Remove all suspended loads. Cover surface opening. Take down Tripod by performing setup steps (see above) in reverse sequence starting with removal of leg base chain. To unlock legs, tilt Tripod slightly, pull down on leg and hinge inward. Secure legs with lower strap to carry. ATTACH LYNX TRIPOD™/ DYNA-LOCK®, LEG-MOUNT BRACKET ONLY TO THIS LEG.

ROSE MANUFACTURING COMPANY.

2250 South Tejon Street
 Englewood, CO 80110
 U.S.A.
 (303) 922-6246
 1-800 722-1231

P/N 10021713

Part Number/N° de Pièce
 Date of Mfr./Date de Manuf.
 Serial Number/ N° de Série

LABEL P/N 620979, REV.A

9.0 INSPECTION BEFORE EACH USE

9.1 INSPECTION FREQUENCY

The Lynx Tripod Fall-Rescue Work System must be inspected by the user before each use. Additionally, the Lynx Tripod must be inspected by a competent person other than the user at intervals of no more than six months. The competent person inspection is referred to as Formal Inspection.

If the Lynx Tripod has been subjected to fall arrest forces, it must be immediately removed from use and marked as "UNUSABLE" until subjected to a Formal Inspection and approved for use by a competent person inspector.

9.2 PROCEDURE FOR INSPECTION BEFORE EACH USE

- Step 1:** Inspect the Lynx Tripod labels to verify that they are present and legible. See section 4 for location of labels. See section 10 for the specific labels that should be present and the information contained on them. Check the Formal Inspection Grid to be sure a Formal Inspection has been performed within the last six months. If the Grid does not indicate that a Formal Inspection has been performed within the last six months (by being punched), or if any labels are missing or illegible, remove the Lynx Tripod from use and mark it as "UNUSABLE" until a Formal Inspection is performed by a competent person.
- Step 2:** Inspect head assembly for corrosion, broken or cracked welds, deformation, fractures, cracks, altered or missing elements, burns, and heat and chemical exposures.
- Step 3:** Inspect all metallic parts (i.e. head, legs, leg pins, attachment pins, feet, leg base chain) for deformation, fractures, cracks, corrosion, deep pitting, burrs, sharp edges, cuts, deep nicks, missing or loose parts, improper function, and evidence of excessive heat or chemical exposures.
- Step 4:** Inspect all non-metallic parts (i.e. skid-resistant foot pads and labels) for cut, broken, excessively worn, missing and loose parts. (Labels are to be additionally checked in accordance with Step 1 above.) Inspect for evidence of burns and excessive heat and chemical exposures.
- Step 5:** Check the function of the Lynx Tripod legs. Legs should move smoothly in the leg pockets and should seat firmly when moved to the fully open position. The lower legs should slide smoothly within the upper legs along their entire length. Lynx Tripod feet should pivot easily and remain flat on the ground when the Lynx Tripod is erected.
- Step 6:** Inspect each component and subsystem of the complete system in accordance with the associated manufacturer's instructions. See section 6 for a description of the make-up of the different system types.

9.3 CORRECTIVE ACTION

When inspection in accordance with section 11.2 reveals signs of inadequate maintenance, the Lynx Tripod must be immediately removed from service and marked as "UNUSABLE" until destroyed or subjected to maintenance by the user's organization in accordance with section 9. Defects, damage, excessive wear and/or aging are generally repairable by the factory. If detected, immediately remove the Lynx Tripod from use and mark it as "UNUSABLE" until repaired. For final disposition, submit the Lynx Tripod to a competent person who is authorized to perform Formal Inspection. If there is any question as to reparability, contact MSA or a service center authorized in writing by MSA before further use of the Lynx Tripod.

10.0 FORMAL INSPECTION

CAUTION

Only MSA or parties with written authorization from MSA may make repairs to the Lynx Tripod.

10.1 FORMAL INSPECTION PROCEDURAL STEPS

- Step 1:** Record on the LOG the Model No., Serial No. and Date Made information shown on this user instruction and from the product labels. Record the inspector's name and inspection date.
- Step 2:** Starting with the metallic category of parts shown on the LOG, inspect each part (inspection point) one at a time. Refer to the DIAGRAM for identification of each Inspection Point. Each part must be inspected for the possible presence of the conditions shown on the CHECKLIST. Enter in the Condition column on the LOG the proper Condition Code (listed on the CHECKLIST) or "FAIL" if a defect exists. If there is any question whether the Lynx Tripod condition has materially changed since the last Formal Inspection, retrieve and review the prior Formal Inspection records for the specific Lynx Tripod.
- Step 3:** Repeat steps 2 and 3 for the non-metallic categories of part types.
- Step 4:** Determine whether the part (inspection point) is acceptable or not acceptable. If a Priority 1 inspection point has a defective condition, enter in the Overall Assessment column of the LOG the proper code taken from the CHECKLIST (e.g. MN, NN) or simply "FAIL." For Priority 2 inspection points, count the number of defective conditions identified in the Condition column of the LOG. If there is a total of three or more defective conditions for Priority 2 inspection points the Lynx Tripod is not acceptable for further use.
- Step 5:** Determine disposition of the Lynx Tripod. If in step 5 it has been determined that the Lynx Tripod is not acceptable, enter "N" or "FAIL" in the Disposition space on the LOG. In addition, a notation should be made in this space as to whether the Lynx Tripod is to be destroyed, returned to manufacturer/distributor, etc.
- Step 6:** If in step 5 it has been determined that the Lynx Tripod is acceptable for further use, enter "A" or "PASS" in the Disposition space on the LOG. Mark the Formal Inspection Grid on the appropriate Lynx Tripod label with the date (month/year) corresponding to the inspection date to indicate to Lynx Tripod users that the product has passed inspection as of that date.
- Step 7:** File the LOG for future reference.

10.2 FORMAL INSPECTION CHECKLIST AND CODES

TYPE OF PART INSPECTED	CONDITION CODE	COND. CODE	OVERALL ASSESSMENT	LEGEND
Metallic	Deformed/fractured	M1	MA - (Metallic acceptable) MN- (Metallic not acceptable)	<p>Disposition:</p> <p>A - (Acceptable) N - (Not acceptable)</p> <p>Enter "A" (or "PASS") or "N" (or "FAIL") in "Disposition" blank on Formal Inspection Log.</p> <p>Criteria for disposition of "N" (Not acceptable):</p> <p>(1) If there is one or more Overall Assessment Code of "N" type (e.g. MN, NN) on a Priority 1 item,</p> <p style="text-align: center;">or</p> <p>(2) If there are three or more Overall Assessment Codes of "N" type on a Priority 2 item.</p>
	Corroded/deep pits	M2		
	Missing/loose	M3		
	Heat exposure	M4		
	Chemical exposure	M5		
	Burrs/sharp edges	M6		
	Cuts/deep nicks	M7		
	Malfunction	M8		
	Other	M9		
	No visible change	M0		
Non-Metallic	Cut/broken	N1	NA - (Non-Metallic acceptable) NN - (Non-Metallic not acceptable)	<p>(1) If there is one or more Overall Assessment Code of "N" type (e.g. MN, NN) on a Priority 1 item,</p> <p style="text-align: center;">or</p> <p>(2) If there are three or more Overall Assessment Codes of "N" type on a Priority 2 item.</p>
	Wear damage	N2		
	Missing/loose	N3		
	Burns/heat exposure	N4		
	Chemical exposure	N5		
	Cracked/Split	N6		
	Other	N7		
	No visible change	N0		

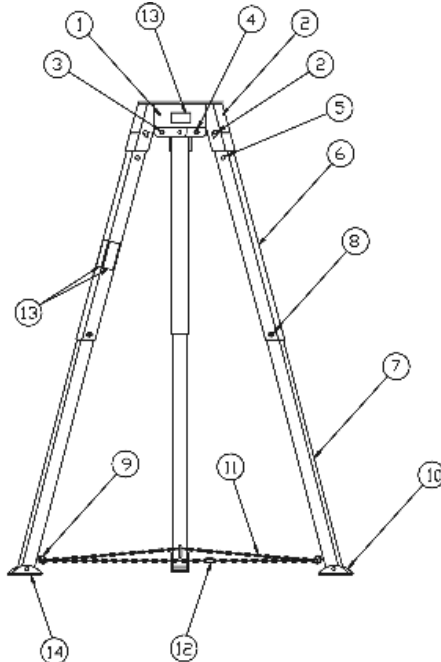

10.3 FORMAL INSPECTION LOG

Model No.: _____ Inspector: _____
 Serial No.: _____ Inspection Date: _____
 Date Made: _____ Disposition: _____

INSP. POINT	DESCRIPTION	QTY/LT	PTY	COND (a)	OVERALL ASSESS.(a)	COMMENTS
METALLIC PARTS						
LYNX TRIPOD HEAD						
1	Head Weldment	1	1			
2	Pivot Pin with Attached Ring	3	1			
3	Hitch Pin	1	1			
4	Positive Locking Pin	1	1			
LYNX TRIPOD LEGS						
5	Clevis Pin with Attached Ring	3	1			
6	Upper Leg	3	1			
7	Lower Leg	3	1			
8	Positive Locking Pin	3	1			
9	Chain Connector	3	1			
10	Foot	3	1			
11	Leg Base Chain	1	1			
12	Screw Lock Link	1	1			
NON-METALLIC PARTS						
13	Labels	3	1			
14	Skid-Resistant Pad	3	1			

WARRANTY

Express Warranty – MSA warrants that the product furnished is free from mechanical defects or faulty workmanship for a period of one (1) year from first use or eighteen (18) months from date of shipment, whichever occurs first, provided it is maintained and used in accordance with MSA's instructions and/or recommendations. Replacement parts and repairs are warranted for ninety (90) days from the date of repair of the product or sale of the replacement part, whichever occurs first. MSA shall be released from all obligations under this warranty in the event repairs or modifications are made by persons other than its own authorized service personnel or if the warranty claim results from misuse of the product. No agent, employee or representative of MSA may bind MSA to any affirmation, representation or modification of the warranty concerning the goods sold under this contract. MSA makes no warranty concerning components or accessories not manufactured by MSA, but will pass on to the Purchaser all warranties of manufacturers of such components. **THIS WARRANTY IS IN LIEU OF ALL OTHER WARRANTIES, EXPRESS, IMPLIED OR STATUTORY, AND IS STRICTLY LIMITED TO THE TERMS HEREOF. MSA SPECIFICALLY DISCLAIMS ANY WARRANTY OF MERCHANTABILITY OR FITNESS FOR A PARTICULAR PURPOSE.**

Exclusive Remedy - It is expressly agreed that the Purchaser's sole and exclusive remedy for breach of the above warranty, for any tortious conduct of MSA, or for any other cause of action, shall be the repair and/or replacement, at MSA's option, of any equipment or parts thereof, that after examination by MSA are proven to be defective. Replacement equipment and/or parts will be provided at no cost to the Purchaser, F.O.B. Purchaser's named place of destination. Failure of MSA to successfully repair any nonconforming product shall not cause the remedy established hereby to fail of its essential purpose.

Exclusion of Consequential Damages - Purchaser specifically understands and agrees that under no circumstances will MSA be liable to Purchaser for economic, special, incidental, or consequential damages or losses of any kind whatsoever, including but not limited to, loss of anticipated profits and any other loss caused by reason of the non-operation of the goods. This exclusion is applicable to claims for breach of warranty, tortious conduct or any other cause of action against MSA.

For additional information, please contact the Customer Service Department at 1-800-MSA-2222 (1-800-672-2222).

Lynx Tripod™, Dyna-Glide™, Dynescape™, Lynx Hoist™, Fallbloc™, Remote Connect/Disconnect System, Beamglide™, Dyna-Lock®, and Lynx Rescuer™ are trademarks, rights to which are held by MSA, U.S.A. Protected by the following U.S. patents: 4,589,523; 4,434,536; 5,361,867. Foreign patents issued and applied for.