



## ACCOMPANIES YOU.

### Owner's Manual

For Australian refrigerator models:

N314E.3F (93 liter 3-way operation with LP gas, 240 volts AC, or 12 volts DC )

N414E.3F (128 liter 3-way operation with LP gas, 240 volts AC, or 12 volts DC )

N514E.3F (164 liter 3-way operation with LP gas, 240 volts AC, or 12 volts DC )



Improper installation, adjustment, alteration, service or maintenance can cause personal injury or property damage. Refer to this manual. For assistance or additional information, contact a qualified installer, service agency, or the LP gas supplier.

#### FOR YOUR SAFETY

Do not store or use gasoline or other flammable vapors and liquid in the vicinity of this or any other appliance.

#### FOR YOUR SAFETY

If you smell gas:

1. Open windows.
2. Don't touch electrical switches.
3. Extinguish any open flame.
4. Immediately call your gas supplier.

# Table of Contents

---

For defined warranty terms, please see the one page warranty statement included in the product information packet.

Safety Awareness.....	2
Safety Instructions.....	3
About Your Refrigerator.....	4
Storage volume.....	4
Leveling.....	4
Operation during travel.....	4
Food compartment.....	4
Flip-up shelf.....	4
Door bins.....	4
Adjustable Shelves.....	4
Freezer compartment.....	5
Door latch for travel and storage.....	5
Operating the Refrigerator Controls.....	5
LED Control Panel.....	5
Turning the refrigerator on.....	5
Selecting the operation Mode.....	5
Selecting the cooling level.....	6
Cooling unit ventilation Fan.....	6
Ignition LP Gas operation.....	7
Start up - AC operation.....	7
Start up - DC operation.....	7
Shut down.....	7
DC Operation Precautions and Guidelines.....	8
Effects of High Altitude on LP Gas Operation.....	8
Refrigerator Care Checklist.....	9
Defrosting.....	9
Cleaning.....	10
Drip tray.....	10
Door Sealing.....	10
Refrigerator Maintenance Checklist.....	11
Refrigerator Storage.....	11
Refrigerator Maintenance.....	12
LP Gas flame appearance.....	12
Remove and clean the burner orifice.....	12
Remove the Refrigerator.....	13
Reinstall the Refrigerator.....	14
Replacement Parts.....	14
Wiring Pictorial.....	15
Wiring Schematic.....	16

## Safety Awareness

---

Read this manual carefully and understand the contents before you use the refrigerator.

Be aware of possible safety hazards when you see the safety alert symbol on the refrigerator and in this manual. A signal word follows the safety alert symbol and identifies the danger of the hazard. Carefully read the descriptions of these signal words to fully know their meanings. They are for your safety.



**This signal word means a hazard which, if ignored, can cause dangerous personal injury, death, or much property damage.**



**This signal word means a hazard which, if ignored, can cause small personal injury or much property damage.**

## Safety Instructions

---



- The storage of flammable materials behind or around the refrigerator creates a fire hazard. Do not use the area behind the refrigerator to store anything, especially flammable materials (gasoline, cleaning supplies, etc.)
- Do not remove the ground prong from the refrigerator AC power cord. Do not use a two prong adapter or extension cord on the AC power cord. If the AC power cord is damaged, it must be replaced by a qualified Recreational Vehicle dealer or an authorized Thetford Service Center in order to avoid a hazard.
- A circuit overload can result in an electrical fire if the wires and/or fuses are not the correct size. Either use the wire and fuse sizes as written in the "Installation Manual" or refer to your local codes for the correct wire and fuse sizes.
- Incorrect installation, adjustment, change to, or maintenance of this refrigerator can cause personal injury, property damage, or both. Have service and maintenance work done by your dealer or by a Thetford authorized Service Center.
- Disconnect both the AC and DC power sources before doing any maintenance work on the refrigerator. All service work on this refrigerator must be done by a qualified service technician.
- Do not bypass or change the refrigerator's electrical components or features.
- This refrigerator is not intended for use by children or by infirm persons unless they have been sufficiently supervised by a responsible person to make sure that they can use the refrigerator safely.
- Young children should be supervised to make sure that they do not play with the refrigerator.
- When you discard an appliance, remove all doors to prevent accidental entrapment and suffocation.
- Do not spray liquids near electrical outlets, connections, or the refrigerator components. Many liquids are electrically conductive and can cause a shock hazard, electrical shorts, and in some cases fire.
- Do not use electrical appliances inside the food storage compartment of the refrigerator unless they are of the type recommended by the manufacturer.
- At regular intervals, make sure that the refrigerator flue the burner, the vent areas, and the ventilation air pathway between the vents are completely free from any flammable material or blockage. After a period of storage, it is especially important to check these areas for any flammable material or blockage caused by animals.



- The refrigerator cooling system is under pressure. Do not try to repair or to recharge a defective cooling system. The cooling system contains sodium chromate. The breathing of certain chromium compounds can cause cancer. The cooling system contents can cause severe skin and eye burns, and can ignite and burn with an intense flame. Do not bend, drop, weld, move, drill, puncture, or hit the cooling system.



- The rear of the refrigerator has sharp edges and corners. To prevent cuts or abrasions when working on the refrigerator, be careful and wear cut resistant gloves.

## About Your Refrigerator

### Storage Volume:

This refrigerator is made to store fresh and frozen foods and for making ice.

	N314E.3F	N414E.3F	N514E.3F
Total capacity	93 L	128 L	164 L
Freezer capacity	11 L	20 L	20 L
Food compartment capacity	82 L	108 L	144 L

### Leveling:



The refrigerator is made to operate within 3° off level side-to-side and 6° off level front-to-back (as looking at the front of the refrigerator). Operating it at more than these limits can cause damage to the cooling system and create a risk of personal injury or property damage. Make sure the vehicle is level before you operate the refrigerator.

### Operation during travel:

While the refrigerator should be level when the vehicle is stopped, performance during travel is not usually effected. For safety and performance, the refrigerator controls will not allow the refrigerator to operate on LP gas while the vehicle is moving or for 15 minutes after the vehicle engine is turned off.

### Food compartment:

Ignite or start up the refrigerator and let it cool for eight hours before loading with food. If the refrigerator does not start to cool down after about two hours, contact your dealer or an authorized Thetford Service Center.

For the best cooling performance:

- Let air move freely inside the entire food compartment.
- Do not cover the shelves with plastic, paper, etc.

To decrease the amount of ice that collects on the cooling fins:

- Cover all liquids and moist foods.
- Let all hot foods cool before putting them in the refrigerator.
- Do not open the door any longer than necessary.

### Flip-up shelf (N414 / N514):

The flip-up shelf supplies a space to store tall bottles. To use the flip-up shelf, lift the center of the shelf and fold it up against the inside wall of the refrigerator.

### Door Bins:

You may put the door bins [52] of the fresh food compartment in a location that best meets your need (See Art01114). To remove the bins, lift them over the locator and pull them forward. To install the bins, push them onto the locator.



*Do not wash the door bins in a dishwasher. The door bins are not dishwasher safe.*

### Adjustable shelves:

The shelves in the fresh food compartment are made so you can remove them or move them. To remove or move each shelf of the fresh food compartment:

- Remove the screw from the retainer of each shelf at the rear of the refrigerator.
- Pull each shelf forward out of the slot.
- Push each shelf fully into the slot that you wish.
- Attach the retainer with the screw.

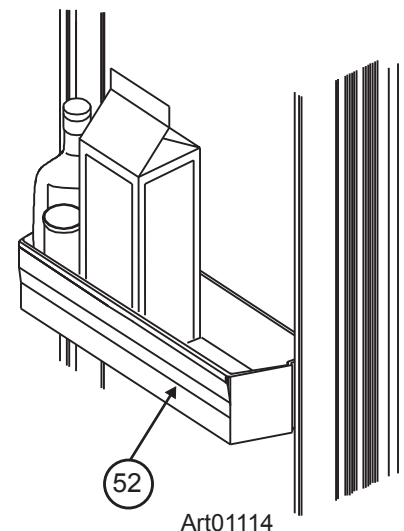

## Freezer compartment:

The freezer compartment is made to keep pre-frozen food frozen and not to quick freeze food. Keep pre-frozen foods in the freezer compartment.

### NOTICE

*Do not put other items on the ice tray while the water is freezing. The water freezes more rapidly if the thermostat is at the coldest temperature setting.*

## Door latch for travel and storage:

During travel, the door latch prevents the door from opening. There are no chains, slides, or any devices that you must engage.

During storage, the door latch prevents the door from completely closing. Use it to prevent odors when the refrigerator is shut down for a long period of time.

To use the door latch for storage (See Art00979):

- Open the door just so the door latch [161] is between the ribs [166] of the latch plate [162].

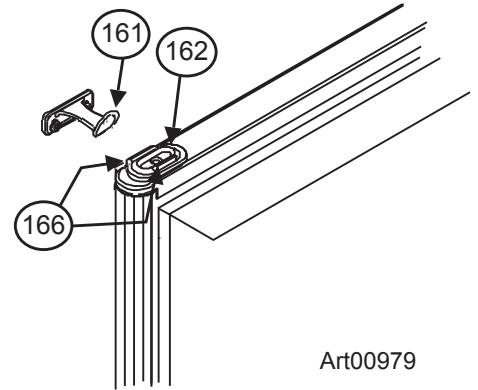

## Operating the Refrigerator Controls

### LED Control Panel:

The control display panel is located between the freezer door and the fresh food door (See Art02518).

On/Off switch .....	30
Selector switch.....	207
Confirmation button.....	307
Mode indicator .....	276
Cooling level indicators.....	308

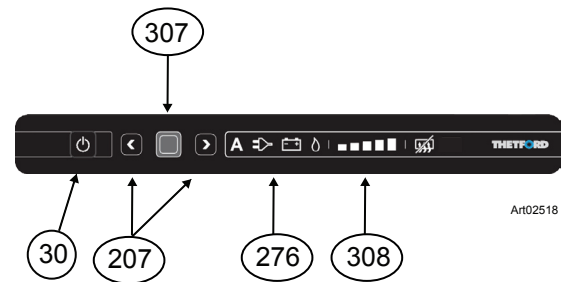

### Turning the refrigerator on:

- Press and hold the On/Off switch [30] for one (1) second.
  - Part of the On/Off switch appears green.
  - The current mode indicator [276] and the cooling level indicator [308] illuminate and will dim after ten (10) seconds.
  - The light in the On/Off switch will remain on.

### NOTICE

*To check the operating mode and the cooling level at any time, briefly press the confirmation button or the selector switch. The mode indicator and the cooling level indicator illuminate for ten (10) seconds.*

### Selecting the operating mode:

- Turn the refrigerator on.
- Press and hold the confirmation button [307] for two (2) seconds.
  - The mode indicator will start to flash.
- Press either of the selector switches [207] until the desired mode indicator illuminates.
- Press the confirmation button [307] twice to start operation in the desired mode.



Auto Mode

The refrigerator control automatically selects the power source. The control selects AC electric first. If AC electric is not available, the control selects DC electric. If DC electric is not available, the control selects LP gas.



230VAC

The refrigerator operates on AC electric.



12VDC

The refrigerator operates on DC electric.



Gas

The refrigerator operates on LP gas.

### Selecting the cooling level:

- Press and hold the confirmation button for two (2) seconds.
  - The current mode indicator [276] will start to flash.
- Press the confirmation button again so that the cooling level indicators [308] start to flash.
- Press either of the selector switches until the desired cooling level is illuminated.
- Press the confirmation button to set the cooling level.

minimum cooling level  maximum cooling level

#### **NOTICE**

*If the cooling load changes, you must manually change the thermostat to maintain the same temperature inside the refrigerator.*

When the outside air temperature is below 10° C, the refrigerator may have a tendency to freeze food at the colder temperature settings. To reduce the tendency to freeze food:

- Set the refrigerator controls to a lower cooling level.
- Keep the refrigerator full.
- Put foods that are more likely to freeze on the lower shelf.

### Cooling unit ventilation fan:

This refrigerator is equipped with a fan, which is located on the rear of the refrigerator. The fan improves the refrigerator performance when the ambient temperature is more than 38°C. The fan switch [252] is located on the front control. (See Art02519)

The thermostat controls the fan when the fan switch is turned on. The fan will come on intermittently depending on ambient temperature. The fan will not operate when the fan switch is turned off, regardless of ambient temperature

The fan requires 12VDC power. Before turning the fan on, make sure that the refrigerator is connected to 12VDC power and the vehicle battery has sufficient capacity.

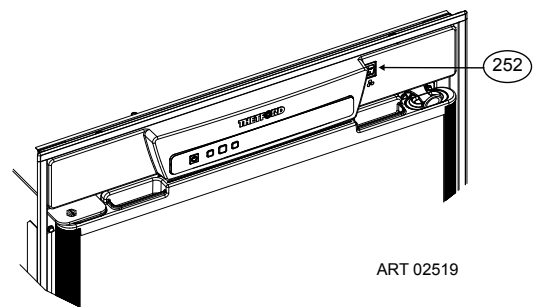

## Ignition – LP gas operation

- Open the valve on the LP gas storage tank.
- Put the refrigerator into LP gas mode.
- Set the refrigerator at the maximum cooling setting.

### NOTICE

*You will hear a clicking sound indicating that the controls are sending a spark to the burner. If the flame does not ignite within 30 seconds, the gas safety valve will close and the gas indicator (  ) and temperature LEDs will begin to flash. Switch the refrigerator off and on and select the gas source again.*

- If the flame does not ignite after several attempts, contact your dealer or authorized Thetford Service Center.
- When the burner lights, set the refrigerator to the desired cooling level.

## Start up – AC operation

- Make sure that 230VAC power is available to the refrigerator.
- Put the refrigerator into AC mode (  ).
- Set the desired cooling level.

## Start up – DC operation

- Make sure that 12VDC power is available to the refrigerator.
- Put the refrigerator into DC mode (  ).
- Set the desired cooling level.

## Shut down:

Press and hold the on/off button for two (2) seconds. All LEDs will turn off.

## **DC operation precautions and guidelines:**

The DC operation is not intended for the initial start up and cooling of the refrigerator. Always use either the AC or LP gas mode to initially start up and cool the refrigerator. The refrigerator and its contents must be cooled and the temperature must be steady before you operate the refrigerator on DC.

This refrigerator is made to operate on 12VDC power while your vehicle is "in transit". Operate the refrigerator on DC power only when the vehicle engine is running.

Keep in mind the following electrical precautions for DC operation of the refrigerator:

For the refrigerator to operate correctly on DC power, the battery must be maintained in a fully charged condition.

- The capacity of the battery charging system must be more than what is necessary for the refrigerator and other DC appliances.
- While the vehicle engine is running, make sure the voltage of the DC power supply leads at the refrigerator is more than 11.5VDC.

## **Effects of High Altitude on LP Gas Operation**

---

When you operate the refrigerator on LP gas at altitudes higher than 1.7 km above sea level:

- You may experience reduced cooling performance of the refrigerator.
- You may experience burner outages.

To avoid these possible problems, Thetford recommends that you operate the refrigerator on AC when at altitudes higher than 1.7 km above sea level.



## Refrigerator Care Checklist

---

Your refrigerator will give you years of trouble free service if you do these simple checks every three to six months:

- Keep the food compartment and the freezer clean. See "Cleaning".
- Defrost the refrigerator as necessary. See "Defrosting".
- Make sure the door seals correctly. See "Door Sealing".
- Be aware of any cooling changes that are not because of weather, loading, or LP gas control changes. If changes occur, contact your dealer or an authorized Service Center.
- Make sure the gas supply is Universal LP gas only.
- When in LP gas operation, examine the appearance of the flame. See "LP Gas Flame Appearance".
- Make sure the air flow in the lower intake vent, through the refrigerator condenser and coils and out the upper exhaust vent is not blocked or decreased.
- Make sure the area behind the refrigerator is clear. Do not use the area behind the refrigerator for storage of any materials, especially gasoline and other flammable vapors and liquids.

## Defrosting

---

The cooling fins of the refrigerator operate at less than 0°C and will naturally form frost from humidity, which is always present in the air. The humidity inside the refrigerator increases:

- with higher outside temperature and humidity.
- with the storage of non-sealed fresh foods or warm foods.
- with the amount of time that the door(s) are open.
- with any air leakage into the refrigerator.

It is normal for frost to collect inside the freezer. Excess frost decreases the cooling performance of the refrigerator. Defrost the refrigerator and freezer as necessary:

- Remove all items from the refrigerator.
- Turn the refrigerator OFF.

**NOTICE** *Defrosting the refrigerator makes excess water inside the refrigerator.*

- Remove the drain hose from the drip cup at the rear of the refrigerator (N414 and N514 models only).
- Put the drain hose into a two liter or larger container to capture water (N414 and N514 models only).
- Put dry towels (etc.) inside the refrigerator and freezer to absorb melted frost.



**High temperatures can cause the inside surfaces of the refrigerator to warp or melt. Do not use pans of HOT water, a hair dryer, or any other high temperature devices to defrost the refrigerator. Do not use any hard or sharp objects to remove frost. Damage to the interior of the refrigerator can occur.**

- To increase the speed of defrosting, put pans of WARM water in the refrigerator and freezer.
- Remove the wet towels (etc.) and dry the interior.
- Remove the drain hose from the large container and put the drain hose back into the drip cup (N414 and N514 models only).
- Remove the large container from the enclosure.
- Start up the refrigerator.
- Allow the refrigerator to cool down.
- Return all food to the refrigerator.

## Cleaning

---

A good time to clean the refrigerator is just after you defrost it.

Clean the inside of the refrigerator as often as necessary to avoid food odors:

- Remove all items from the refrigerator.

**NOTICE** Do not use abrasive cleaners, chemicals, or scouring pads because they can damage the interior of the refrigerator.

- Wash the interior with a solution of liquid dish detergent and warm water.
- Rinse with a solution of baking soda and clean water.
- Dry with a clean cloth.
- Return all items to the refrigerator.

### Drip tray:

To remove and clean the drip tray:

- Make sure that the drip tray is empty of water.
- Pull the drain tube plug out from the inside of the drip tray and out of the drain hose.
- Pull the drip tray forward to remove from the slots in the refrigerator cabinet.
- Clean the drip tray.
- Put the drain tube plug down into the drip tray and push the drip tray back into the original position.
- Push the drain hose back onto the drain tube plug.

## Door Sealing

---

If the door does not seal correctly, excess frost will collect inside the refrigerator. Make sure the door seals correctly:

- Close the door on a piece of paper that is about the size and thickness of a dollar bill (See Art00980).
- Gently pull the paper.
  - You should feel a slight drag between the gasket and the cabinet.
  - Do this on all four sides of the door.
  - If you do not feel a slight drag on the paper, the door is not sealing correctly:
    - Make sure the screws of the hinges are tight.
    - Make sure the door gasket does not touch the door latch:
      - If the door gasket touches the door latch, loosen the screws of the door latch.
      - Raise the door latch just so it does not touch and tighten the screws of the door latch.
    - Make sure the door latch holds the door closed.

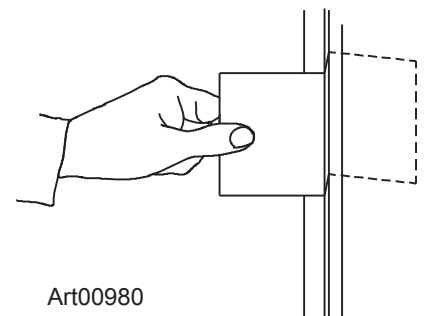

## Refrigerator Maintenance Checklist

---

Read and understand the following maintenance sections of this manual.

### NOTICE

*Thetford is not responsible for installation, adjustment, alteration, service, or maintenance performed by anyone other than a qualified Recreational Vehicle dealer or an authorized Thetford Service Center.*

Have a qualified Recreational Vehicle dealer or an authorized Thetford Service Center do these annual safety and maintenance checks:

- Examine the LP gas supply lines for leaks.
  - Replace or repair if necessary.
- Make sure the LP gas gas pressure is 2.7 kPa.
  - Adjust if necessary.
- Make sure the combustion seal is complete and intact.
  - Replace or repair it if necessary.
- Make sure the burner and the burner orifice are clean (See Art00956).
  - Clean if necessary.
- Make sure the electrode spark gap [167] is 3-5 mm (See Art02458).
  - Adjust if necessary.
- Make sure the AC voltage is 216 - 252 volts and the DC voltage is 11.7 - 15.4 volts.
- Make sure the electrode tip is clean and secure.
- Make sure the area at the rear of the refrigerator is free of any combustible materials, gasoline, and other flammable vapors and liquids.

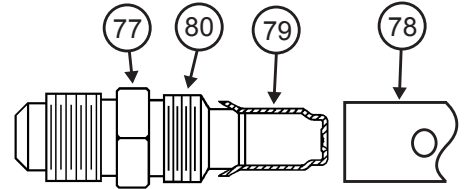

Art 00956

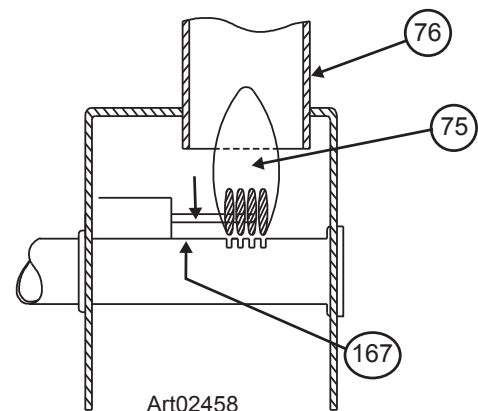

Art02458

## Refrigerator Storage

---

Before the refrigerator is stored for an extended (seasonal) period of time:

- Defrost and clean the interior of the refrigerator.
- Close the doors with the storage latch.

If the refrigerator is stored for an extended period of time, before start up:

- Make sure there are no obstructions in the vents, the ventilation air pathway, the burner, the orifice, or the flue area.

## Refrigerator Maintenance

### LP gas flame appearance:

While in LP gas operation, examine the appearance of the LP gas flame:

- Set the refrigerator to the maximum cooling level.
- Open the lower intake vent.



**The burner box cover can be hot. Wear gloves to avoid burns.**

- Open the burner box door [165] and look at the LP gas flame [75] (See Art02458 and Art02453).
  - The flame should be:
    - a darker blue color on the inside of the flame and a lighter blue color on the outside of the flame.
    - a constant shape without flickering.
  - Contact your dealer or Thetford authorized service center if the flame is:
    - yellow
    - flickering or changing shape.
  - Make sure the flame does not touch the inside of the flue tube [76].
  - If the flame touches the inside of the flue tube, contact your dealer or an authorized Thetford Service Center.

- Close the burner box door.

### Remove and clean the burner orifice:



*Your dealer or an authorized Thetford Service Center must do this procedure.*

To remove and clean the burner orifice:

- Close the valve at the LP gas tank(s).
- Shut down the refrigerator.



**The burner box cover can be hot. Wear gloves to avoid burns.**

- Open the lower intake vent.
- Remove the drip cup by removing one screw.
- Remove the burner box cover by removing one screw.



**To avoid possible LP gas leaks, always use two wrenches to loosen and tighten the LP gas supply line at the manual shut off valve of the refrigerator.**

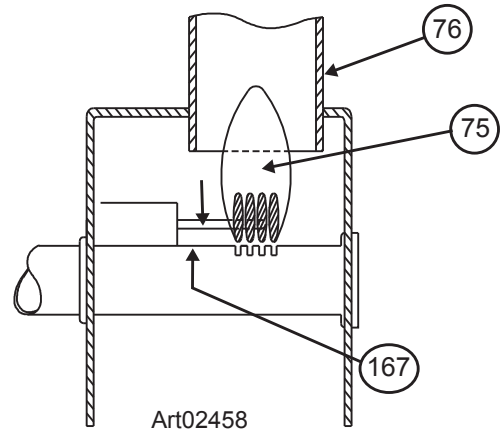

Art02458

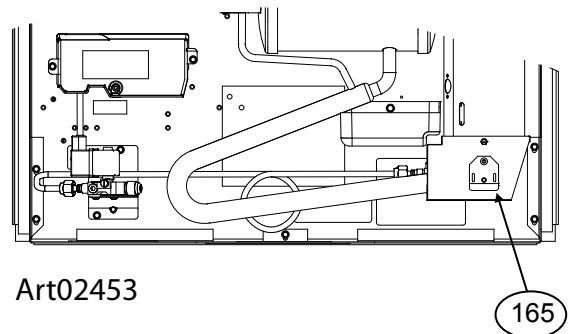

Art02453

165

- Remove the flare nut from the orifice assembly [77] (See Art00956).
- Remove the orifice assembly from the burner [78].



**Do not try to remove the orifice [79] from the orifice adapter [80] when cleaning. Removal will damage the orifice and seal of the orifice and can cause an LP gas leak. Leaking LP gas can ignite or explode which can result in dangerous personal injury or death. Do not clean the orifice with a pin or other objects.**

- Clean the orifice assembly with air pressure and alcohol only.
- Using a wrench, assemble the orifice assembly to the burner.
  - Assemble the flare nut to the orifice assembly.
  - Tighten the flare nut by hand.
  - Hold the orifice assembly securely and, using a wrench, tighten the flare nut 1/4 revolution only.
- Examine all of the connections for LP gas leaks.
- Clean the burner box.
- Assemble the burner box cover.
- Assemble the drip cup.

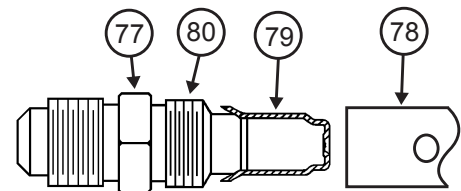

Art 00956

## Remove the Refrigerator

### NOTICE

Your dealer or an authorized Thetford Service Center must do this procedure.



**The rear of the refrigerator has sharp edges and corners. To prevent cuts or abrasions when working on the refrigerator, be careful and wear cut resistant gloves.**

1. Close the valve at the LP gas tank(s).



**To avoid possible LP gas leaks, always use two wrenches to loosen and tighten the LP gas supply line at the refrigerator's manual shut off valve.**

2. Open the lower intake vent and remove the LP gas supply line from the 3/8 inch male flare fitting of the refrigerator.
3. Remove the AC power cord from the power point.
4. Remove the DC wiring from the refrigerator:
  - Remove the DC wiring from the battery or the converter of the vehicle.
  - Put a mark on the DC wires so you can put them back in the correct location.
  - Remove the DC wires from the refrigerator.
5. Remove the screws which fasten the refrigerator to the floor.
6. Remove the door from the refrigerator if necessary.
7. Remove the screws which fasten the refrigerator to the wall.
8. Remove the refrigerator from the opening.
9. Attach the door to the refrigerator if necessary.

## Reinstall the Refrigerator

---

### **NOTICE**

Your dealer or an authorized Thetford Service Center must do this procedure.

### **WARNING**

Make sure the combustion seal is not broken, is completely around the refrigerator mounting flanges, and is between the mounting flanges and the wall of the enclosure. If the combustion seal is not complete, exhaust fumes can be present in the living area of the vehicle. The breathing of exhaust fumes can cause dizziness, nausea, and in extreme cases, death.

1. Push the refrigerator completely into the enclosure.
2. Remove the door from the refrigerator.
3. Put the screws through the mounting flanges and into the wall.
4. Attach the door to the refrigerator

### **CAUTION**

The rear of the refrigerator has sharp edges and corners. To prevent cuts or abrasions when working on the refrigerator, be careful and wear cut resistant gloves.

5. Open the lower intake vent and put the screws through the refrigerator rear corner brackets and into the floor.

### **WARNING**

To avoid possible LP gas leaks, always use two wrenches to loosen and tighten the LP gas supply line at the refrigerator's manual shut off valve.

6. Attach the LP gas supply line to the manual shutoff valve of the refrigerator.
7. Open the valve at the LP gas tank(s).

### **WARNING**

Do not allow the leak checking solution to touch the electrical components. Many liquids are electrically conductive and can cause a shock hazard, electrical shorts, and in some cases fire.

8. Examine the gas supply line for leaks.
9. Connect the DC wiring to the refrigerator:
  - Install the DC fuse or connect the DC wiring to the battery or the converter.
  - Connect the DC wires from the refrigerator.
10. Connect the AC power cord to the receptacle.

## Replacement Parts

---

You may purchase replacement parts through your local Recreational Vehicle dealer or an authorized Thetford Service Center.

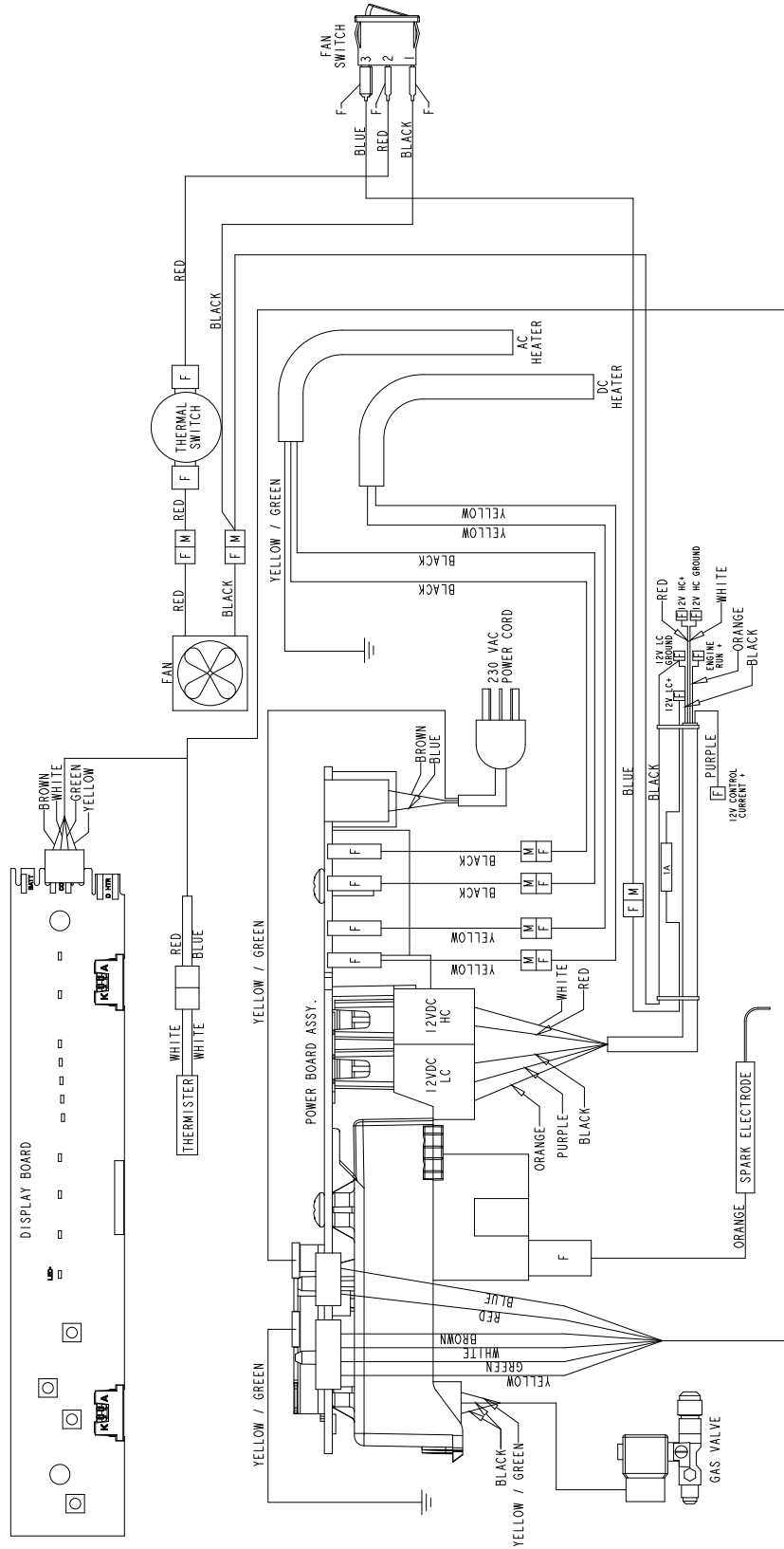

# Wiring Schematic

