Optima™ Dispenser

Owner's Manual

ComTech Energy

Compression Technology Corporation
8620 Escarpment Way, Units 11-14
Milton, Ontario, Canada
L9T 0M1
Ph. 1-833-264-3835

Document revision history

Document No. RFD.020.MNL.00		
Revision #	Date	Description
02	June 2017	Editorial updates and corrections, Production release.
03	April 2021	Name and Logo

Code compliance

Kraus CNG dispensers are manufactured to comply with the following codes and standards:

North America
<ul style="list-style-type: none">✓ American Society of Mechanical Engineers (ASME) Boiler and Pressure Code✓ American Society of Mechanical Engineers (ASME) B31.3 – Process Piping✓ Canadian Gas Association (CGA) B108 NGV Refueling Stations Installation Code✓ Canadian Standards Association (CSA) C22.1 Canadian Electrical Code (CEC) Part I✓ National Fire Protection Association (NFPA) 52 Standard for Compressed Natural Gas (CNG) Vehicular Fuel Systems✓ National Fire Protection Association (NFPA) 70 National Electrical Code

CONTENTS

1. INTRODUCTION	1
1.1 About this manual	1
1.2 Additional references	2
1.3 Contact information	2
1.4 Warnings and notifications	3
1.5 Warranty information	3
1.6 The Retail CNG Optima™ dispenser	4
1.7 Dispenser theory of operation	4
1.7.1 MICON NEXTGEN 1.0®	4
1.7.2 Buffer storage systems	5
1.7.3 Cascade storage systems	5
1.7.4 The Retail unit layout	6
2. SAFETY	7
2.1 General safety	7
2.2 Filling safety	8
2.3 Dispenser hose safety	9
2.4 Maintenance safety	10
2.5 Leak test safety	11
3. INSTALLATION AND SETUP	12
3.1 Installation guidelines	12
3.2 Pre-installation	14
3.2.1 Site preparation	14
3.2.2 Uncrating the dispenser	15
3.2.3 Lifting and anchoring the dispenser	16
3.3 Installation	17
3.3.1 Electrical and communication connections	17
3.3.2 Pressure line connection	17
3.3.3 Filters	18
3.3.4 Attaching the hose	21
3.4 Startup procedures	23
3.4.1 Powering the dispenser	23
3.4.2 Pressurizing the dispenser	24
3.4.3 Connecting the Manager-keypad	25
3.4.4 Enabling 2-wire mode and setting pump/hose IDs	27
3.4.5 Configuring the POS System	28
3.4.6 Commissioning	29
4. OPERATION AND MAINTENANCE	30

4.1 Filling procedure	30
4.2 Programming the MICON®	31
4.2.1 Manager Menu/Programming mode	31
4.2.2 Disabling Programming mode	33
4.3 Dispenser maintenance	35
4.3.1 General dispenser maintenance guidelines	35
4.3.2 Dispenser venting procedure	36
4.3.3 Leak monitoring	37
4.4 Component maintenance	38
4.4.1 MICON® mainboard	38
4.4.2 KAF 402™ solenoid inlet valve	39
4.4.3 Inline filters	39
4.4.4 Air purge system	40
5. TROUBLESHOOTING	41
5.1 MICON® fault codes	41
5.2 System fault codes	45
5.3 Dispenser issues	45
5.3.1 Voltage statuses	49
APPENDIX	1
A.1 Component descriptions and specifications	1
Air purge system components	1
Power supply	5
Air purge system/authorization relay	5
Micro Motion® CNG050 flow meter	6
KAF 402™ solenoid inlet valve	8
Fueling nozzles	9
A.2 Maintenance task list	10
GLOSSARY	1
INDEX	1

This page intentionally left blank

This page intentionally left blank

DISCLAIMER

This manual and the information contained herein are not intended to provide you with any advice on product design, filling station specifications, installation of equipment, or similar matters and should not be relied upon for such purposes. Neither ComTech Energy nor any of its employees or agents are your professional advisers. You should assess whether you require such advisers and additional information and, where appropriate, seek independent professional advice. Kraus, its subsidiaries and affiliates, are not responsible in any manner for direct, indirect, special or consequential damages however caused arising from your use of this manual and the information contained herein.

1. INTRODUCTION

1.1 About this manual

Purpose

This manual is designed to provide installation, operation, and maintenance guidelines and procedures for the Kraus Retail compressed natural gas (CNG) Optima™ dispensers.

Intended users

This manual is designed to be clear, comprehensive, and available to anyone installing, maintaining, or overseeing the operation of the Kraus Retail CNG Optima™ dispensers.

Scope

This manual is divided into five chapters:

1. INTRODUCTION

This chapter provides general information about this manual and the Retail CNG Optima™ dispenser.

2. SAFETY

This chapter provides general installation, operation, and maintenance safety guidelines.

3. INSTALLATION AND SETUP

This chapter provides installation and configuration guidelines and procedures for the Retail CNG Optima™ dispenser.

4. OPERATION AND MAINTENANCE

This chapter provides operation and maintenance guidelines and procedures for the Retail CNG Optima™ dispenser.

5. TROUBLESHOOTING

This chapter provides general troubleshooting guidelines for possible installation, operation, and maintenance issues.

1.2 Additional references

In addition to this manual, the following document is also provided with each dispenser package:

- Quick-Start Guide—Optima™ CNG Dispenser (RFD.010)

The following documents are available on request:

- MICON NEXTGEN 1.0® Owner's Manual (MNG0001.MNL)
- Hazardous Locations Control Drawing (MNG0002.MNL)
- Engineering package
 - Flow schematic
 - Electrical schematic
 - Construction drawings
- Final inspection checklist
- Quality control notices
- Quality control information packages

If you are missing any of the documents listed above or require additional assistance at any time, please contact Technical Support.

1.3 Contact information

ComTech Energy
8620 Escarpment Way, Units 11-14
Milton, Ontario
Canada, L9T 0M1

www.comtechenergy.ca

Phone: 1-833-264-3835

Email: support@comtechenergy.ca

1.4 Warnings and notifications

The following indicators provide various warnings and notifications throughout this manual:



This indicator provides helpful tips and other advice on proper equipment installation, usage, and maintenance.



This indicator provides important notifications about the dispenser and its components.



This indicator provides critical warnings that may help prevent human injury and equipment damage.

1.5 Warranty information

For questions or concerns regarding dispenser-warranty policies, please contact Sales.

1.6 The Retail CNG Optima™ dispenser

The Retail CNG Optima™ dispenser is available in a single or multiple-line configuration. Each configuration is available in standard, high or split-flow systems; P30, P36, or split-pressure; single or dual hose setup; and buffer or cascade sequencing.

Additionally, the Retail CNG dispenser incorporates an industry-leading retail design that includes an embedded card reader, keypad, receipt printer, full-color display and secondary display. *Table 1.1* below describes these customizable features.

Table 1.1: Retail dispenser configurations

Dispenser model	Retail CNG Optima™ Dispenser
Storage system	Buffer (1 large bank) or Cascade (up to 3 banks)
Filling system	High-flow or Standard-flow or Split-flow
Filling pressure	P30 or P36 or Split-pressure
Hose configuration	Single or Dual

1.7 Dispenser theory of operation

This section explains how the Kraus MICON NEXTGEN 1.0® pump-controller and KAF 402™ solenoid valves operate to control gas flow within CNG dispensers.

1.7.1 MICON NEXTGEN 1.0®

Kraus MICON NEXTGEN 1.0® pump-controller is an inexpensive alternative to using PLC units for operating fuel dispensers. For CNG dispensers, the MICON® takes readings from the mass flow meter, pressure transducer, and temperature probe to determine a final fill pressure that is based on a series of algorithms in accordance with the *Ideal Gas Law*, “ $PV = nRT$ ”. The result is a controlled fill of a vehicle’s CNG tank to a safe maximum limit.

After the fueling nozzle is attached and a fill is authorized, the MICON® opens all KAF 402™ solenoid valve(s) and dispenses CNG into the vehicle’s receptacle for four seconds. After the four seconds, the MICON® closes the valve(s) and performs a reading of the vehicle tank pressure and ambient temperature. Based on a combination of the initial reading and *Ideal Gas Law* calculations, the MICON® determines a target-fill-pressure.

1.7.2 Buffer storage systems

A buffer storage system comprises a large storage bank with a single supply line to the dispenser, which is controlled by one KAF 402™ solenoid valve to start and stop gas flow.

After the target-fill-pressure is calculated, the solenoid valve remains open for fuel delivery until the target-fill-pressure or minimum flow setting is reached.

1.7.3 Cascade storage systems

Cascade storage systems typically consist of three separate storage banks—a low, mid, and high bank. The low bank holds approximately 70% of the total volume of storage, while the mid and high banks hold 20% and 10% respectively.

Upon authorization, the MICON® will open all three banks for 4 seconds to ensure there is sufficient gas flow to continue with the fill. The banks will then close for another 4 seconds for the target-fill calculation. Once the target-fill-pressure is calculated, the low-bank will reopen and deliver fuel until the flow rate drops to a predetermined level—set in the MICON®. When this level is reached, the mid-bank solenoid valve will reopen to deliver the fuel. If more pressure is needed, the same sequence will occur to access the high-bank until the target-fill-pressure or minimum flow setting is reached.

1.7.4 The Retail unit layout

A single-hose Retail CNG Optima™ dispenser—Please refer to the *Engineering package* for a view of internal components

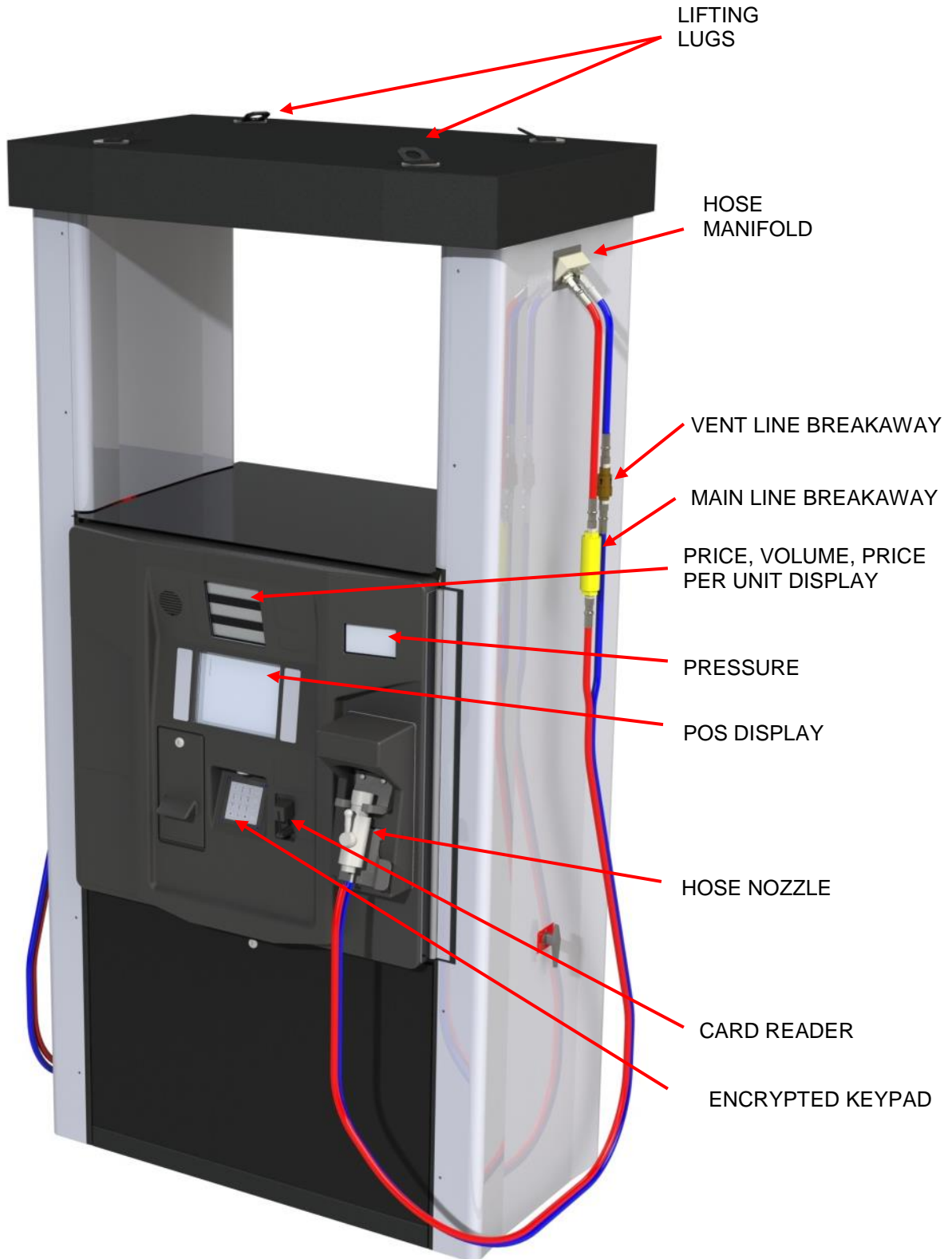

2. SAFETY



Compressed Natural Gas (CNG) can pose great danger if mishandled. Please be sure to read and understand this section before installing, operating, or maintaining CNG dispensers.



It is necessary to comply with all safety precautions and other instructions described throughout this manual to properly install, operate, and maintain ComTech Energy-manufactured CNG dispensers.

2.1 General safety

Where it is applicable, local regulations take precedence over the guidelines listed in this section. Please ensure that all personnel are familiar with all applicable regulations and observe the following guidelines when working with fuel dispensers:

- Do not smoke or allow open flames and naked lights within 15 feet or 5 meters of any gas installation.
- Do not adjust, remove, or bypass any protective devices.
- Electrical equipment and its protection must comply with the regulations applicable to the hazard of the location.
- Transportation, installation, commissioning, operation, maintenance, and repairs should only be carried out by qualified personnel in accordance with the regulations for operation and safety.
- Electrical connections must comply with applicable local regulations.
- Piping and other components, which are not supplied by ComTech Energy, must be suitable for the respective working pressure. If necessary, they must be tested and protected by pressure-unloading devices.
- Systems must be entirely vented before any maintenance or repair procedures are carried out.
- Do not store flammable materials, such as oily rags, in or around the dispensing unit.

2.2 Filling safety

Please observe the following guidelines when overseeing the use of all Kraus-CNG dispensers:

- Be aware of emergency procedures and emergency telephone numbers.
- Be aware of the locations of fire extinguishers and the “Emergency Shut Down” (ESD) buttons.
- Ensure all operators and users are properly trained before any fueling transactions.
- Do not allow any vehicles to be unattended while fueling.
- Ensure that all automatic transmission vehicles are placed in “park” or the emergency brake is applied for all manual transmission vehicles before allowing any fueling transactions.
- Ensure that all vehicle ignitions, electrical systems, and radios—including short-wave communication equipment—are shut-off before allowing any fueling transactions.
- Ensure the fuel receptacle is inspected and matches the dispenser filling nozzle before attempting any fueling transactions.
- Ensure all users adhere to the operating procedures described in *Section 4.1* when fueling.
- Ensure all users are aware that pressure from the nozzle must be vented before disengaging it from the vehicle.
- Ensure that all users replace the dispenser nozzle firmly onto the holder immediately after refueling.

2.3 Dispenser hose safety

Please observe the following guidelines prior to installing or maintaining CNG dispenser-hoses and related components:

- Inspect the hose assembly before each use.

Replace the hose if any of the following conditions are observed:

- The jacket of the hose appears abnormal
- A gas leak or any reason to believe there is a gas leak
- The couplings are damaged
- The hose is damaged in any way, including cuts, cracks, bulges, blisters, or abrasions
- The reinforcement is exposed through the jacket
- Spring guards are missing or detached from couplings
- Couplings and spring guards show evidence of slippage or looseness

- Do not exceed the maximum recommended working pressure of the hose: 5,000 psi/345 bar.
- Do not twist, kink, or torque the hose assembly.
- Never attempt to repair or re-couple a damaged hose.
- Do not use a strength member for pulling or lifting equipment.



The hose assembly for Retail CNG dispensers are designed to convey static electricity. It is imperative that the hose assembly be properly grounded to the CNG unit it is attached to.



For additional information about dispenser hoses, please refer to the specification tag provided by the manufacturer or contact Technical Support at 1-833-264-3835.

2.4 Maintenance safety

Please observe the following guidelines prior to maintaining any Kraus CNG dispensers:

- Only properly trained or qualified personnel should be permitted to maintain and repair CNG equipment. When in doubt, please refer to the equipment supplier or service agent.
- Always adhere to the manufacturer guidelines for proper installation and maintenance of all dispensers and dispenser-components.
- All maintenance and repair work of pressure vessels and other safety equipment must be conducted under the appropriate codes, then tested and accepted by the inspection authority.
- The dispenser must be powered-off and completely vented, unless otherwise specified.
- Never perform welding processes near gas systems.
- Always cover disassembled parts and openings with a clean rag, paper, or adhesive to keep them clean and avoid contamination.
- Do not clean any parts with flammable solvent. Clean and rinse all parts carefully with compressed air.
- Be sure to wear necessary safety equipment during maintenance and repair. Eye protection is absolutely necessary when cleaning with compressed air.
- Wear hearing, hand, and eye protection when bleeding filters and lines. Be sure to keep body parts away from the discharge orifice.
- Do not touch bare wires and live current-carrying parts while the electrical system is energized.
- Never tighten or loosen any fitting when it is under pressure.

- Always use proper thread lubricants and sealant on tapered pipe threads.
- Never turn a fitting body. Instead, hold fitting body and turn the nut.
- After completing any work on process gas piping systems and its components, always purge the system thoroughly with a non-corrosive inert gas, such as nitrogen, before introducing natural gas.
- Ensure that you have not left any tools, cleaning equipment, or any loose parts inside the dispenser.



Never allow problems to go unreported. Both your company and supplier will benefit from the full disclosure of all dispenser issues.

2.5 Leak test safety

Please observe the following guidelines before performing leak tests on ComTech Energy-manufactured CNG dispensers:

- Ensure the area surrounding the dispenser being serviced is closed off to all customers and unauthorized personnel. Use any appropriate barricade and signage to ensure safety.
- It is recommended that protective shields be placed around potentially harmful areas of the dispenser being serviced.
- Service personnel must wear all appropriate safety gear, such as helmets with eye and/or facial protection and body shields.

3. INSTALLATION AND SETUP

3.1 Installation guidelines

Please observe the following guidelines prior to installing any ComTech Energy-manufactured CNG dispenser:

- All electrical and mechanical installations must comply with the provisions of the local authority having jurisdiction.
 - All electrical installations must only be carried out by a licensed electrical journeyman.
 - All high-pressure gas connections should only be carried out by qualified and experienced personnel.
 - Safety valve discharge gases must be funneled safely away from the working area using tubing or piping with comparable pressure ratings to the tubing or piping used within the dispenser.
 - Be sure to allow room inside the dispenser pit to properly tie-in the gas lines to the inline filters and manual isolation valves.
 - Where soil displacement is apparent, gas connections upstream of the dispenser must be made with flexible hoses.
 - The dispenser frame enclosure must be securely bolted to a concrete foundation or to a structural steel base. Adequate support must be provided for each unit of the dispensing system, independent of piping, tubing, or conduit that may be connected to the dispenser.
 - A pressure relief device may be installed directly upstream of the dispenser—in compliance with the ASME Boiler and Pressure Vessel Code—to limit the pressure at the inlet of the dispenser to a value no greater than the maximum working pressure of the dispenser.
- The pressure relief device must communicate directly with the pressure-containing component it is designed to protect—valves between the protected component and the inlet to the pressure relief device are not permitted.

- All dispensers must be equipped with an emergency shut-off device that will terminate the gas supply to the dispenser in the event that the dispenser is upset or sheared from its foundation for any reason.
- All dispensers must only be used for gas compositions specified within *SAE J1616: Recommended Practice for Compressed Natural Gas Vehicle*.

3.2 Pre-installation



Kraus CNG dispensers must be situated in such a way that there are no obstructions, such as a wall or gate, that may entangle the dispenser hose. This is to ensure proper functioning of the hose assembly's breakaway coupling.

3.2.1 Site preparation

Please observe the following guidelines prior to constructing dispenser pits:

- Be sure to allow room inside the dispenser pit to properly tie-in the gas lines to the inline filters and manual isolation valves.
- Make provisions for tubing and electrical conduits prior to pouring the concrete pad.
- Filters must be installed upstream of the dispenser.
- Due to potential weld slag, filings, rust, dirt, and water, dispensing lines should be purged to the atmosphere at the dispenser. This can be done by blowing nitrogen through the lines.
- All dispensing lines must be purged, pressurized, and leak tested. Afterwards, manual isolating valves in the dispenser pit must also be leak tested. The dispenser must only be connected to the lines after these have been accomplished.



Please refer to your *Construction drawings* for dispenser dimensions.

3.2.2 Uncrating the dispenser



Ensure that the dispenser crate is placed on a smooth and level surface before removing any crate panels.



All dispenser packages contain additional parts, accessories, and documents that are vital to the installation, operation, and maintenance of the dispenser. Be sure to set these items aside in a safe and easily accessible area.

Dispenser keys may be found on one of the authorization handles.

1. Inspect the crate for any damages that may have occurred during shipping. If any damages are found:
 - Take pictures of the damages
 - Note the damages
 - Contact ComTech Energy
2. Starting with the top panel, remove all screws and/or nails and detach the top panel. Repeat this process to remove all side panels.
3. Remove all protective wrapping by hand; knives and other sharp objects may damage the dispenser.
4. Inspect the dispenser for any damages. If any damages are found, repeat the procedure indicated in step 1.
5. Remove lag bolts from base rails to free the dispenser from the bottom pallet.
6. Locate and review the crating check list to ensure that all items are accounted for. If you are missing any items, please contact Technical Support at 1-833-264-3835.

3.2.3 Lifting and anchoring the dispenser



Kraus CNG dispensers weigh at least 1,200 lbs/545 kg; be sure all lifting and anchoring equipment are suitable for the weight.

1. Locate the lifting lugs on top of the dispenser. A step-stool or step-ladder may be required to get a full view.
2. Attach lifting straps to the lifting lugs using clevises.
3. Hoist the dispenser off the pallet with a suitable forklift or crane and carefully move the dispenser over the dispenser pit.
4. Ensure the area directly below the dispenser is free of electrical wires, tubing, and other obstacles.
5. Lower the dispenser slowly into the pit.
6. Fasten the dispenser to the pit frame or concrete base with—at the minimum— $\frac{1}{2}$ " NC, Grade 8 steel bolts with Grade 8 steel washers.



Ensure there is sufficient room to complete tubing and wiring connections before securing the dispenser to the foundation.



The supply ground cable must be securely connected to the dispenser frame.

3.3 Installation

3.3.1 Electrical and communication connections



Electrical installations must only be carried out by licensed electrical journeymen.



All interconnection tubings and fittings are sold independently of ComTech Energy.

Always adhere to manufacturer standards for appropriate swaging and tightening specifications.

Electrical

The dispenser's main electrical connections are done at the terminal strip, located in the explosion-proof junction box in the lower cabinet of the dispenser. An electrical conduit, labeled "ELECTRICAL," is provided to allow optimum protection and direct routing to the explosion-proof junction box.

Please refer to the electrical schematic within the *Engineering package* for electrical connection specifications.

Communication

An electrical conduit, labeled "COMMUNICATION," is provided in the lower cabinet for all communication wiring. This conduit allows direct routing to the upper cabinet where the POS system and pump connections are made.

Please refer to the electrical schematic within the *Engineering package* for communication connection specifications.

3.3.2 Pressure line connection



High-pressure gas connections must only be carried out by qualified and experienced personnel.

Please refer to the flow schematic within the *Engineering package* for pressure line connection specifications.

3.3.3 Filters

CNG may be filtered in one of two methods:

- **Particulate** filtration removes solid particles from gases; ensuring only clean gas is dispensed into a vehicle.
- **Coalescing** filtration removes solid particles with the same efficiency as particulate filtration, but also removes water aerosols and droplets from gases; ensuring only clean and dry gas is dispensed into a vehicle. This is the standard and recommended method of filtration for all Kraus CNG dispensers.

Filter size and placement

Filter sizes and their placement depend on the configuration of the dispenser. High-flow dispensers require large filters that may be placed in one of the following locations:

- In the dispenser pit if it is large enough to house the filters, while providing enough room to drain and change filter elements
- Upstream of the dispenser pit, on the dispenser supply lines between the priority panel and the dispenser

See *Figure 1* below for high-flow filter placement options.

Standard-flow dispensers use smaller filters that can often be placed in the lower cabinet of the dispenser unless otherwise indicated.



If filters are not being supplied by ComTech Energy ensure that they are properly rated for the dispenser's filling system.

You may contact Technical Support at 1-833-264-3835 for any questions regarding dispenser configurations.

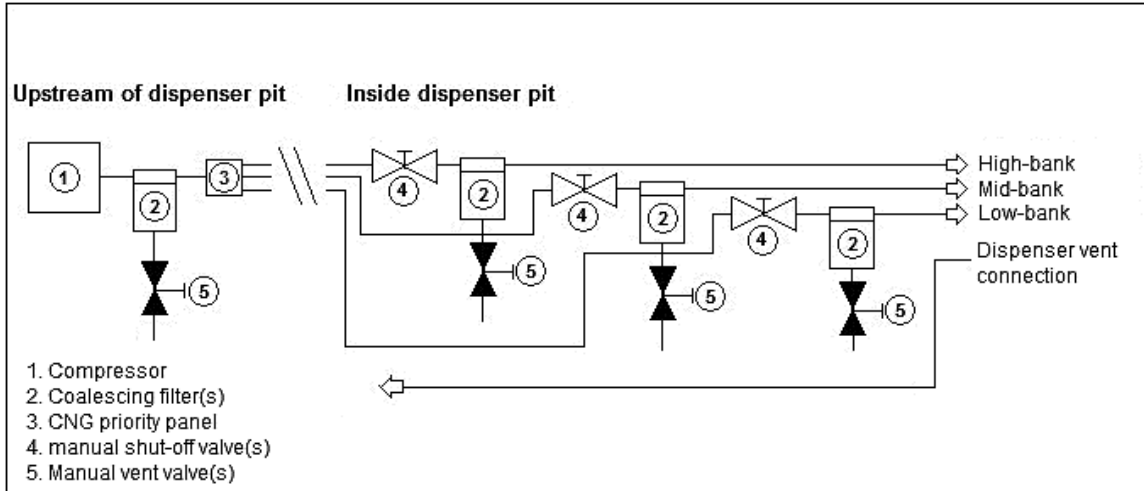

Figure 1: High-flow filter placement

Filter installation guidelines



Filter housings are pressure vessels and must only be used within their allowable working pressure, within their stated temperature range.

- As pressure vessels, filter housings must be leak-tight. It is considered good practice to use pipe sealants on fittings prior to connecting the filter housing ports.
- Ensure the filters are visible and easily accessible for periodic draining and maintenance.
- Install the filters on a level pipeline and mount vertically. Be sure to leave one bowl length of clearance to allow for element removal.
- Ensure that fittings are always inspected during servicing and adjusted accordingly.
- Avoid swapping the heads and bowls of one filter assembly to another.

3.3.4 Attaching the hose

Kraus CNG dispensers use Parker brand hoses and hose fittings. Hose sizes are specific to dispenser configurations, but are available in various lengths. Please see the information sheet attached to the hose package or contact Technical Support at 1-833-264-3835 for further specification.

Please be sure to read and understand *Section 2.3—Dispenser hose safety* before proceeding.



**If your hose is unusable or if you have any reason to believe it may be unusable, please contact Technical Support immediately.
Do not use defective or damaged hoses.**



If you are operating a split-pressure or split-flow dispenser, ensure that you attach the correct hose to the proper connection.

1. Remove the hose from its packaging.
2. Inspect the hose for any defects or damages that may have occurred during shipment.

NOTE: Never use defective or damaged hoses. If a defect or any damage is found, contact Technical Support immediately.

3. Attach the main line to the hose manifold, located on the side; along the top of the dispenser. Hose manifolds may be on both sides, depending on the dispenser's hose configuration.
4. Hand-tighten the main line fitting to the manifold so it will still be loose enough to turn.
5. Straighten the hose and place the nozzle into the holder. The loose fitting should allow the hose to find its natural resting position.
6. Tighten the main line fitting at the manifold with a backup wrench. Hose connections do not require sealants or Teflon tape.
7. Attach the vent line to the corresponding manifold connection and tighten with a backup wrench.



To help avoid abrasive damage to the hoses, do not allow any part of the hose to be in contact with the ground or dispenser while it is holstered. If this is the case, the hose may be too long; please contact our Technical Support Department immediately.

Breakaway couplings

All Kraus CNG dispenser hoses are equipped with a breakaway safety feature. Breakaway couplings are in place to prevent the flow of natural gas should a vehicle drive away from a dispenser while the nozzle and hose are still connected to the vehicle's receptacle.



If a breakaway occurs, the entire hose assembly must be examined by a qualified service representative prior to any reconnections.



In the event of a breakaway, dispenser hose assemblies may only be reconnected if the breakaway was clean; otherwise, the assembly will have to be rebuilt using the breakaway rebuild kit or completely replaced with new parts and fittings. Please consult our Technical Support Department before proceeding with either option.

Reconnecting procedure

1. Vent the dispenser system and hose assembly before attempting any reconnections. Please refer to *Section 4.2—Maintenance* for dispenser-venting procedures.
2. Clean dirt, debris, and other obstructions from both sides of the breakaway unit.
3. Inspect both parts of the breakaway unit. Ensure that O-ring seals are not damaged.

NOTE: Never reconnect assemblies if any components are damaged.

4. Inspect the stationary module and ensure that the inner garter spring is intact and properly situated in the groove.
5. Insert the breakaway unit into the stationary module by aligning the wrench flats of the unit with the lining of the module.
6. Push the breakaway unit into the stationary module until you feel a click.
7. Perform a leak test to ensure the system and hose assembly are in working condition. Please refer to *Section 4.2—Maintenance* for leak-testing procedures.



Breakaway couplings may require a specialized reconnection tool—contact Technical Support at 1-833-264-3835 for more information.

3.4 Startup procedures

3.4.1 Powering the dispenser

The following steps are guidelines for powering-up the dispenser, assuming all electrical and mechanical connections have been properly installed. Please be sure to read and understand *Chapter 2—Safety* before proceeding.



The dispenser is shipped in “Auto-Authorization mode.” It is recommended that the initial power-up process is done under this mode to facilitate procedures requiring authorization.

1. Remove the bottom panels of the dispenser to access the lower cabinet.
2. Close all manual filter inlet valves, vent valves, and manual shut-off valves.
3. Inspect the Magnehelic gauge; ensure the air pressure is above 0.15 inches-of-water.



For safety purposes, the upper cabinet must maintain a positive air pressure. A purge switch and timer are used to trigger automatic system-shutdowns and startups. If the Magnehelic gauge displays a pressure lower than 0.15, dispenser electronics may not function. You may need to increase the purge fan pressure or inspect the cabinet and air purge system for leaks.

4. Turn on the power to the dispenser from the breaker box.

NOTE: The dispenser-electronics, POS system, and MICON® will simultaneously initiate the following power-up sequences:

- The Price/Volume display will show the current software version and dispenser model during this sequence. The power-up sequence is complete when the Dollar and Volume displays read **0.00** and **0.000** respectively.
- The digital pressure gauge, located on the secondary display to the right of the main display, will display the Kraus logo during power-up. The power-up cycle is complete when the secondary display will display a pressure gauge and a flow rate gauge.

3.4.2 Pressurizing the dispenser

The following steps are guidelines for pressurizing the dispenser; the dispenser must be powered-on for this procedure. Please be sure to read and understand *Chapter 2—Safety* before proceeding.



To ensure peak performance, all Kraus CNG dispensers should be leak-tested before initial operation. The first leak test should be done while initially pressurizing the dispenser.



If your dispenser operates over a cascade storage system, complete the following procedure with the low-bank first, the mid-bank second, and the high-bank last.

1. Turn the manual shut-off valve(s), located along the side(s) of the dispenser to the **ON** position.
2. Flip the authorization handles to the **ON** position. This enables you to see the pressure reading on the Secondary Display.
3. Slowly open the inlet valve and allow 100 psi of gas to fill the dispenser.

NOTE: Pressure may be monitored through the digital pressure gauge on the Secondary Display or the mechanical gauge attached to the sensor vent manifold.

4. Close the inlet valve and flip the authorization handle to the **OFF** position once the pressure gauge indicates 100 psi.
5. Apply a leak detector to all fitting connections—we recommend using Snoop® Liquid Detector.

NOTE: If any leaks are detected, please refer to *Section 4.2—Maintenance* for leak repair procedures.

6. If no leaks are found, reauthorize the dispenser by flipping the authorization handles up to the **ON** position.
7. Slowly reopen the valve to allow 500 psi of gas to fill the dispenser.
8. Close the valve once the pressure gauge indicates 500 psi.
9. Reapply the leak detector. See the previous *Note* if leaks are detected.
10. Repeat this process at 500 psi increments until the regular operating pressure is reached. Repeat the process for each inlet valve.

3.4.3 Connecting the Manager-keypad

The Manager-keypad is a flat magnetic keypad connected to a ribbon cable. It allows personnel to configure the dispenser-electronics and POS system parameters; it may be found attached to the inside wall of the upper cabinet. The following steps are guidelines for connecting the keypad to the pump door node.

1. Turn off the power to the dispenser from the breaker box.
2. Open the upper cabinet. You may need the dispenser keys to unlock the cabinet door.
3. Retrieve the Manager-keypad from inside the upper cabinet. The Keypad is a flat magnetic keypad connected to a cable; it may be found attached to the inside wall of the upper cabinet.
4. Connect the keypad to the pin connector labeled “KEYPAD 2” located directly behind the dispenser 3-line display. (see Figure 1). The arrow in *Figure 2* points to the position of the pin connector on the back of the dispenser display.

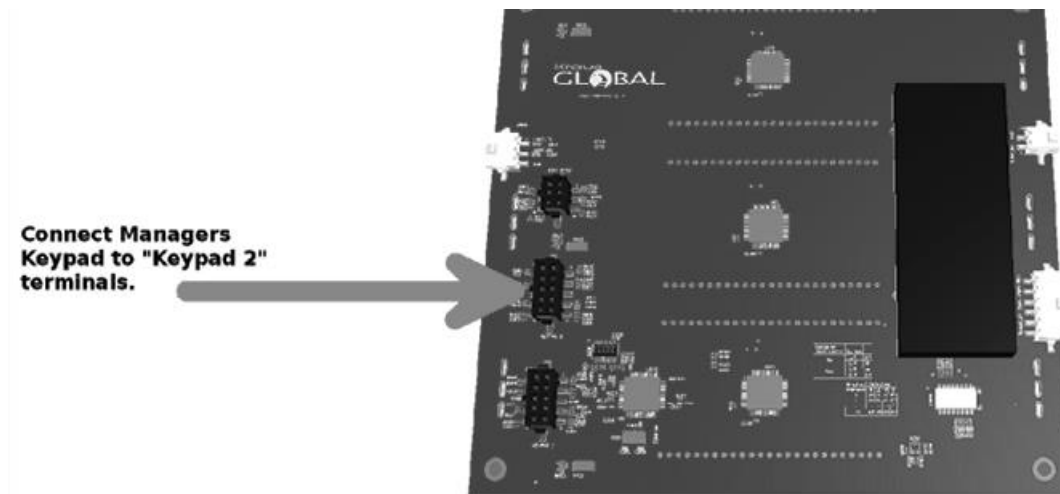

Figure 2: Manager-keypad pin connector behind the dispenser display

3. INSTALLATION AND SETUP



Figure 3: Keypad position at start up

5. Hang the keypad over the cabinet door. This allows the cabinet door to close, while allowing use of the keypad; see *Figure 3*.

6. Ensure the cabinet door is closed and fully sealed.

NOTE: Dispenser-electronics will not function if the upper cabinet is not sufficiently pressurized.

7. Turn on the power to the dispenser at the breaker box.

NOTE: The keypad is now ready for use; you may need to allow all power-up sequences to complete before proceeding.

3.4.4 Enabling 2-wire mode and setting pump/hose IDs

“2-wire mode” is a fill-authorization option that requires customers to complete a payment transaction before a fill may be authorized. By enabling “2-wire mode,” you are disabling “Auto-Authorization mode.”

Enabling “2-wire mode”

1. After connecting the Manager Keypad, enter the password 1234.
2. Press the “DOWN” key until the first line of the Main Display shows the setting “2WR ENAB”.
3. Press the “1” key followed by the “START” key to enable 2-Wire Mode and save setting.
4. Press the “DOWN” key once. The display should now read “2WR ID A”.
5. Enter the desired Hose 1 address (a value from 1-256). Press “START” key to save setting. Figure 4 shows the display for Hose 25 address.
6. Press “DOWN” key once. The display should now read “2WR ID B”.
7. Enter the desired Hose 2 address (a value from 1-256). Press “START” key to save setting.
 8. These settings will not take effect without rebooting the system. To reboot the MICON®, press the “DOWN” key until the first line of the display reads “REBOOT”.
 9. Press the “1” key, followed by the “START” key. The MICON® should now perform a complete reboot. Wait a moment for the system to complete the restart and the new 2-wire configuration should take effect.



Figure 4 - Display for Hose 1, address 25

3.4.5 Configuring the POS System

Preliminary view – Additional features to be included later.

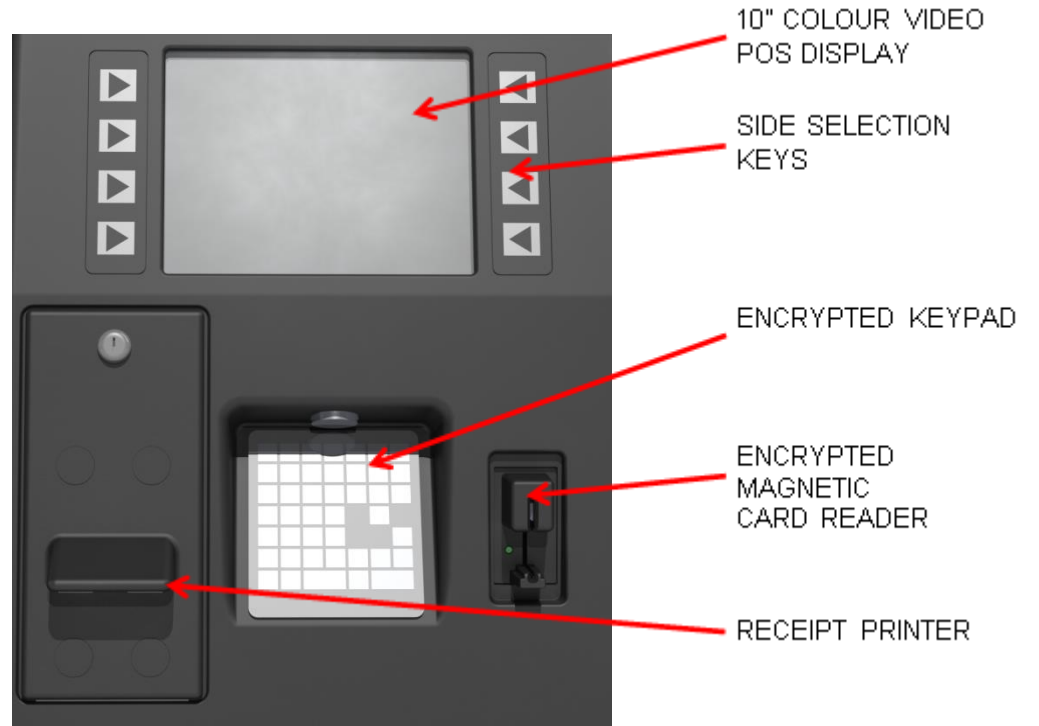

3.4.6 Commissioning

Commissioning is necessary to ensure all dispenser systems, including all components, are installed and function properly, and are successfully turned over. Documenting the commissioning process allows for traceable verification and ensures a systematic approach to minimizing any commissioning oversights.

A commissioning sign-off sheet is included within your dispenser package. This form must be completed, signed, and sent to ComTech Energy within 30 days of commissioning, otherwise the warranty may be voided.

Complete forms may be mailed or emailed to ComTech Energy using the following information:

ComTech Energy
8620 Escarpment Way, Units 11-14
Milton, ON
Canada, L9T 0M1
Email: support@comtechenergy.ca

4. OPERATION AND MAINTENANCE

4.1 Filling procedure

The following is the procedure for filling CNG approved vehicles with the Retail CNG dispenser. Ensure all users observe the guidelines described in *Section 2.2* and adhere to this procedure when fueling.



Ensure all personnel, including users, are aware of emergency shut-down buttons prior to operating CNG fuel dispensers.

1. Ensure the vehicle is in “park” or the parking brake is applied, and the vehicle ignition is turned OFF.
2. Inspect the vehicle’s receptacle and the dispenser hose and nozzle. Do not proceed with fueling or allow further use of the dispenser if any damages or signs of tampering are found; you may contact our Technical Support Department for further assistance: 1-833-264-3835.
3. Remove the dust plug from the vehicle’s CNG receptacle.
4. Lift the refueling nozzle from the holder.
5. Connect the refueling nozzle to the vehicle receptacle.
6. Follow the prompts on the POS display; you may be required to complete a payment transaction before a fill can be authorized.
7. Turn the valve on the nozzle to **FILL**.
8. Flip the authorization handle up to the ON position; fueling will begin after a three-second beep.



Note the following during gas delivery:

- **Gas delivery may create a loud whining sound. This is due to the pressure differential between the dispenser and the vehicle’s storage bank. This is normal and is not a cause for concern.**
- **There may be noticeable pauses as the dispenser accesses multiple storage banks; delivery is not complete until the dispenser beeps for three full seconds.**

9. Flip the authorization handle back down at the end of delivery; a three-second beep will signify the end of delivery.
10. Turn the valve on the nozzle to VENT. This will vent a small amount of gas into the atmosphere and allow you to disconnect the nozzle.
11. Replace the nozzle onto the holder.
12. Replace the dust plug into the vehicle’s CNG receptacle.

4.2 Programming the MICON®

In order to program specific MICON® parameters, the MICON® must be placed in “programming mode” to be able to transmit and receive signals.

4.2.1 Manager Menu/Programming mode

The software on the main control board can be updated remotely over TCP/IP Ethernet, or from a microSD update card. In order to affect any changes to software, the MICON® must be booted in programming mode.

The MICON® can be started in programming mode by enabling the programming mode switch located on the intrinsic safety module inside the MICON® enclosure. It may be necessary to break weights and measures sealing in order to enable programming mode which may require re-inspection by the appropriate authority.

When the board boots in programming mode, the console RS-232 port is activated and the SSH remote access service is started. The watchdog timer is not started by the main application when running in programming mode. Each MICON® control board has a unique root access username and password that is programmed at the factory. While in programming mode, configuration parameters in the manager menu and pricing menu are also enabled. The price-per-unit line of the primary display will display “CFG” in the lower left corner to indicate that the board is in programming mode.

Refer to the MICON NEXTGEN 1.0® owner’s manual for complete details on configuration settings available in the menu systems.

To access the programming switch, perform the following procedure:

1. Disconnect power from the dispenser at the breaker / distribution panel.
2. Shut off gas to the dispenser and ensure that the area is free of hazardous gas / vapour.
2. Open the dispenser door and remove the two sealing bolts from the MICON® enclosure located in the centre of the dispenser. If the dispenser has already been sealed by a weights and measures inspector, it may be necessary to break the lead seals.
3. Toggle the programming switch located at the center of the intrinsic safety module. Please see Figure 3.4. The switch should be in the rightmost position.

4. OPERATION AND MAINTENANCE

4. Replace the sealing bolts and close the dispenser door. If you need to attach the Manager keypad, please refer to Section **Error! eference source not found.** for instructions on how to connect the manager keypad.
5. Restore power to the dispenser and allow it to boot. All settings in the manager and pricing menus should now be unlocked. In addition to unlocking settings, the development console port J8 on the main MICON® board will be activated when in programming mode. This allows a user to connect via serial and login to perform software updates or other maintenance tasks.



Figure 3.4: Programming Switch Location



CAUTION

After shutting down the dispenser, ensure that the area is known to be safe and free of hazardous gasses before opening the dispenser. If the environment cannot be reliably verified as being safe, then allow at least 5 minutes before opening the dispenser as the dispenser may contain hot parts capable of causing ignition.



ATTENTION

To access the programming mode switch, it may be necessary to break weights and measures sealing on the MICON® enclosure. This ensures that any settings that could affect the accuracy of the MICON® cannot be changed once sealed.

4.2.2 Connecting the Manager Keypad

The new MICON® features an intuitive menu system for applying configuration settings. This menu is accessed by connecting the MICON® managers keypad to the primary 3-line display located on the back of the door. The process to connect the manager keypad is as follows:

1. Disconnect power from the dispenser at the breaker / distribution panel.
2. Shut off gas to the dispenser and ensure that the area is free of hazardous gas / vapour.
2. Identify the side 1 display. The display can be identified by observing the address set by the configuration switches **SW200** on the rear of the display. Display 1 should have switches 5, 6, and 7 in the **ON** position and switch 8 in the **OFF** position.
3. Connect the manager keypad to the display on the **KEYPAD 2** terminals. This connection is highlighted below in **Figure 3.5**.
4. Feed the keypad cable through the top of the dispenser door. Close the door over the cable. The door should seal around the cable.
5. Restore power to the dispenser. The purge system timer will restore power to the MICON® after the internal pressure is adequate and enough time has elapsed for several air turns to have occurred. If power does not restore, check that there is not excessive air leaking around the manager keypad cable.



After shutting down the dispenser, ensure that the area is known to be safe and free of hazardous gasses before opening the dispenser. If the environment cannot be reliably verified as being safe, then allow at least 5 minutes before opening the dispenser as the dispenser may contain hot parts capable of causing ignition.



The keypad connector is keyed and will only connect to the display in one orientation.



The keypad connection is designed to be intrinsically safe. This allows for the safe operation of the keypad on the outside of the dispenser.

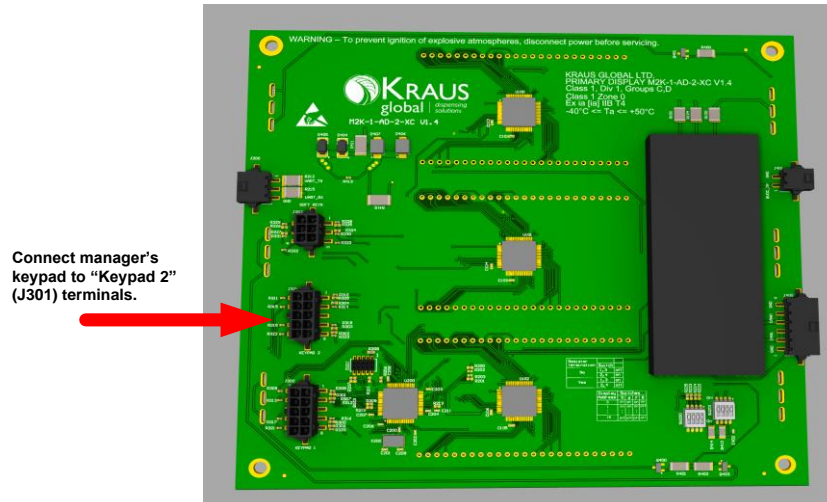

Figure 3.5: Manager Keypad Connector Location

4.2.3 Disabling Programming mode

1. Disconnect power from the dispenser at the breaker / distribution panel.
2. Shut off gas to the dispenser and ensure that the area is free of hazardous gas / vapour.
3. Open the dispenser door and remove the two sealing bolts from the MICON® enclosure located in the centre of the dispenser. If the dispenser has already been sealed by a weights and measures inspector, it may be necessary to break the lead seals.
4. Toggle the programming switch located at the center of the intrinsic safety module. Please see Figure 3.4. The switch should be in the rightmost position.
5. Replace the sealing bolts and close the dispenser door. Disconnect the Manager keypad from the primary display (see Figure 3.5).
6. Restore power to the dispenser and allow it to boot. The dispenser should now be in normal operating mode. The letters "CFG" should **NOT** be displayed on the third line of the primary displays.

4.3 Dispenser maintenance



Please read and understand *Section 2.4—Maintenance safety* before performing any maintenance on fuel dispensers.



Be sure to note and report all dispenser issues. It is considered good practice to use a maintenance log sheet to document all dispenser issues and repairs.

4.3.1 General dispenser maintenance guidelines

- Please refer to the *Maintenance task list* in the *Appendix*, for a detailed maintenance schedule.
- Shut off all manual isolation valves in the dispenser pit after hours and other times when the dispenser will not be in use.
- Ensure that all valves, gauges, and displays are free of obstructions.
- Clean the dispenser on a regular basis. Avoid using pressurized water.
- Perform daily checks for signs of leakage.
- Perform leak inspections of all hoses and fittings every six months with an approved leak detector fluid. Ensure that all leaks are repaired by qualified personnel immediately.
- Perform monthly hose inspections. Check for abrasions, swelling, flatness, cuts, damaged couplings, and other abnormal signs. Replace the hose immediately if any abnormalities are found.
- Depending on installation requirements, we recommend that inline filter elements are checked and replaced two weeks after initial installation.
- Check filter elements every month and replace when necessary.

4.3.2 Dispenser venting procedure

The following steps are guidelines for venting the Retail CNG dispenser.



All CNG dispensers must be completely vented prior to performing any maintenance work, including leak-testing and repairs.

1. Isolate the dispenser by placing highly visible signs or physical barriers to prevent traffic in the immediate area.
2. Ensure the refueling nozzle is replaced in the holder.
3. Ensure there is power to the dispenser. The dispenser must be electrically functional to operate the inlet valves.
4. Ensure the manual shut-off valve(s) is/are open.
5. Close all manual filter inlet valves to terminate gas flow from the storage vessels to the dispenser.
6. Slowly loosen the vent valves at least 3 to 4 turns to vent the trapped gases in the dispenser.

NOTE: Read the pressure gauges to confirm the gas is being vented.



Do not touch any venting pipes throughout this procedure. Rapidly expanding gases may cause sub-zero temperature drops within the vent stacks, which may cause cold burns.

NOTE: At this point, only gases upstream of the sequencing valves, including gas inside the hoses, have been vented; there may still be gases trapped downstream of the sequencing valves down to the filter isolation valves.

7. Lift the authorization handle to authorize a fill. This will open the sequencing valves allow trapped gases to escape.

NOTE: Sequencing valves are only opened for 4 seconds at a time; you may need to authorize a fill several times to vent all trapped gases. Continue authorizing a fill until the pressure gauge reads 0 psi and all venting sounds have ceased.

4.3.3 Leak monitoring

Leaks in dispenser equipment may develop within the first few weeks of operation and, therefore, must be closely monitored throughout this time. Thereafter, routinely scheduled maintenance must be carried out to correct and prevent further leaks.

The following steps are guidelines for detecting and repairing leaks.



NEVER TIGHTEN, LOOSEN, OR ATTEMPT TO REMOVE A PRESSURIZED FITTING.

Leak-testing procedure

1. Remove the bottom panels of the dispenser to access the lower cabinet.
2. Apply a leak detector to all fitting connections—we recommend using Snoop® Liquid Leak Detector.
3. Thoroughly inspect all fitting connections for bubbles, which indicate a leak. Be sure to note or mark the locations where leaks are found.
4. If leaks are found, vent gas from the dispenser—see *Dispenser-venting procedure*—and proceed with repairing the leak.



If a leak appears downstream of a sequencing valve, you must authorize a fill to vent the trapped gas. Continue authorizing a fill until the pressure gauge reads 0 psi and all venting sounds have ceased.

Leak repairing procedure

1. Ensure the dispenser is completely vented.
2. Loosen and retighten the fittings where leaks are found; most fittings can be repaired simply by tightening it.
3. Pressurize the dispenser to 100 psi and reassess all fitting connections with a leak detector.
4. Continue pressurizing the dispenser and testing for leaks at 500 psi intervals until the dispenser reaches regular operating pressures.

NOTE: Repeat steps 1 – 3 if leaks are discovered. If leaks persist, contact our Technical Support Department at 1-833-264-3835.

4.4 Component maintenance

This section provides guidelines and important notifications regarding the maintenance of vital dispenser components.

4.4.1 MICON[®] mainboard



Should the MICON[®] Mainboard or any other circuit board need replacing, please contact ComTech Energy Technical Support at 1-833-264-3835.

4.4.2 KAF 402™ solenoid inlet valve

Kraus' KAF 402™ solenoid valve has been specifically engineered for high-pressure CNG service. It is constructed of materials suitable for use with natural gas and is rated for a burst pressure in excess of 25,000 psi.

To ensure the proper solenoid valve(s) are in proper working condition please observe the following maintenance guidelines:

- The valve(s) must be leak-tested after every 35,000 cycles or every six months, whichever comes first.
- The valve(s) must be rebuilt at least once every three years by qualified service personnel and in accordance with the rebuild procedure described in the KAF 402™ rebuilding specification sheet.



Rebuild kits are required to properly rebuild KAF 402™ solenoid valves for any maintenance or repair purposes. They are sold separately from any dispenser systems; please contact our Sales or Technical Support department at 1-833-264-3835 for any questions.

4.4.3 Inline filters

CNG filtering is a balanced, continuous, and steady state condition occurring at or below rated flow. In order to maintain high-efficiency filtration for your CNG dispenser, ensure that the bowl is kept clean and free of waste build-up.

Filter element replacement procedure

1. Ensure the dispenser is completely vented – SEE Section 4.3.2.
2. Open the filter drain valve to ensure all pressure has been vented.
3. Unthread and remove the bowl—set it aside in a secure location.
4. Remove and discard used filter element and O-ring.
5. Install new filter element.
6. Install new O-ring. Lightly lubricate the new O-ring using a clear silicon-based grease.
7. Apply a thin layer of anti-seize onto the filter bowl threads.
8. Thread the filter bowl to the head, making sure not to pinch O-ring.

4.4.4 Air purge system

Kraus Retail CNG dispensers incorporate an air purge system to ensure the open electronics in the upper cabinet are protected from potential gas leaks that may cause explosion. The air purge system uses a purge fan to maintain a positive air pressure of at least 0.15 inches-of-water in the upper cabinet; otherwise the dispenser system is automatically shut down. A Magnehelic gauge, located in the lower cabinet is used to monitor this pressure.

Purge fan filter maintenance guidelines

- Inspect and clean the purge fan filter once-a-month.
- To clean, rinse the filter with soap and water.
- Dry thoroughly before reinstalling filter.

5. TROUBLESHOOTING

5.1 MICON[®] fault codes

In the event that you encounter an operational error while using the MICON[®], a descriptive fault label and fault code will appear in the volume and price-per-unit displays respectively. An example of a display disconnect error is depicted below in Figure 5.1.

Table 5.1 below provides a list of fault code clearing procedures and Table 5.2 provides a list of fault code summaries with appropriate troubleshooting suggestions.

When a fault occurs, any current transaction will be ended and the MICON[®] will enter the error state. While in the error state, the fault code is displayed. The current transaction details can be obtained via the console and will also be displayed again once the error condition is cleared.



Figure 5.1: Example Error Code



Please contact our Technical Support Department at 1-833-264-3835 for any issues not covered in Tables 5.1 and 5.2 below.

5. TROUBLESHOOTING

Table 5.1: MICON® Fault Code Clearing Procedures

Summary of Fault Clearing Actions	
E 28 - E 51	<ol style="list-style-type: none">1. Correct the source of the error - See Table 5.2.2. Flip the authorization handle down to the OFF position, then back up to the ON position. – OR – activate the manual reset switch (MRST). – OR – write to the corresponding error bit in the Modbus register mapping.
E 76 - E 96	<ol style="list-style-type: none">1. Correct the source of the error - See Table 5.2.2. Activate the manual reset switch (MRST).
E 97	<ol style="list-style-type: none">1. Correct the source of the error - See Table 5.2.2. Flip the authorization handle down to the OFF position, then back up to the ON position. – OR – activate the manual reset switch (MRST) – OR – write to the corresponding error bit in the Modbus register mapping.

Table 5.2: MICON® Fault Codes

Fault Code	Description	Possible Cause	Recommended Action
28 DISP1 DC	Display 1 disconnect	Display has been disconnected or failed.	Check display power connector. Check display communications connector. Check display power supply barrier.
29 EEPROM	EEPROM checksum mismatch	Settings have become corrupted. Software has been updated and settings have changed.	Re-configure settings from defaults. If problem reoccurs frequently, repair/replace main board.
31 DISP2 DC	Display 2 disconnect	Display has been disconnected or failed.	Check display power connector. Check display communications connector. Check display power supply barrier.
40 PWR FAIL	Power failed during fill	Power failure during a fill	After clearing the fault, transaction data is loaded from meter and displayed.
51 EXC FLOW	Excess flow detected	Ruptured hose flow rate has exceed MICON® max flow setting	Check hose for ruptures or other damage. If no hose damage is present, max flow setting may need to be adjusted.
76 P1 RANGE	Pressure transducer 1 out of range	Pressure transducer has gone below 3.8mA or above 21mA	Check pressure transducer wiring. Check pressure display on secondary display. If the pressure fluctuates more than 50 psi when the dispenser is static, then replace transmitter. If pressure reading is not fluctuating, but is reading differently than the pressure gauge check that the MICON® pressure full scale setting matches the full scale of the transmitter.
77 P2 RANGE	Pressure transducer 2 out of range	Pressure transducer has gone below 3.8mA or above 21mA	Check pressure transducer wiring. Check pressure display on secondary display. If the pressure fluctuates more than 50 psi when the dispenser is static, then replace transmitter. If pressure reading is not fluctuating, but is reading differently than the pressure gauge check that the MICON® pressure full scale setting matches the full scale of the transmitter.
78 AT RANGE	Ambient temperature sensor out of range	Ambient temperature sensor has gone outside of the MICON® operating temperature range -40°C to $+50^{\circ}\text{C}$	If the temperature range has actually been exceeded, shutdown the dispenser until the ambient temperature is back within the recommended operating temperature range. If the ambient temperature is incorrect, check wiring of ambient temperature probe. If wiring is good, then replace temperature probe.
79 GT RANGE	Gas temperature out of range	Gas temperature has exceeded mass flow meter operating range -50°C to $+50^{\circ}\text{C}$	Wait for gas temperature to recover. If gas temperature is not correct, then reset/replace mass flow meter.
91 MET1 NC	Meter 1 not connected	Meter is not connected or not responding. Meter has an incorrectly programmed address	Check mass flow meter wiring. Confirm that meter is powered (LED inside meter should be lit or blinking) If meter is powered but not communicating, perform meter marriage procedure. If meter marriage fails, check if meter communications A/B are reversed.
92 MET2 NC	Meter 2 not connected	Meter is not connected or not responding. Meter has an incorrectly programmed address	Check mass flow meter wiring. Confirm that meter is powered (LED inside meter should be lit or blinking) If meter is powered but not communicating, perform meter marriage procedure. If meter marriage fails, check if meter communications A/B are reversed.
93 MET1 SC	Meter 1 short circuit/excess load	Mass flow meter has drawn excessive load or short circuited.	Check meter wiring. Reboot dispenser. If problem persists or reoccurs frequently, replace mass flow meter.
94 MET2 SC	Meter 2 short	Mass flow meter has drawn	Check meter wiring. Reboot dispenser. If problem persists

5. TROUBLESHOOTING

	circuit/excess load	excessive load or short circuited.	or reoccurs frequently, replace mass flow meter.
95 MET1 INT	Meter 1 internal error	An internal mass flow error has occurred.	Check log file for meter internal error code. Reboot dispenser. If problem persists or reoccurs, replace mass flow meter.
96 MET2 INT	Meter 2 internal error	An internal mass flow error has occurred.	Check log file for meter internal error code. Reboot dispenser. If problem persists or reoccurs, replace mass flow meter.
97 CONS COM	Console communications error	An error has occurred with the console/POS communications system.	Check console communications wiring. Check to make sure that console communications modules in the junction box are powered and that their power LEDs are lit. Reboot dispenser and/or console system. If error reoccurs or persists, contact technical support at 1-833-264-3835 for additional troubleshooting.

5.2 System fault codes

TBA.

5.3 Dispenser issues

Please refer to *Table 5.3* for all troubleshooting matters. Please contact our Technical Support Department at 1-833-264-3835 for any issues not covered in Table 5.3 below.



Only trained and qualified service personnel should attempt any troubleshooting and service work to any CNG electrical and mechanical components.

5. TROUBLESHOOTING

Table 5.3: Troubleshooting

ISSUE	POSSIBLE CAUSE(S)	RECOMMENDED ACTION
<ul style="list-style-type: none"> Dispenser allows CNG flow into vehicle without authorization 	<ul style="list-style-type: none"> Low-bank solenoid valve is stuck open 	<ul style="list-style-type: none"> Rebuild low-bank solenoid valve—contact Tech. Support for more information
<ul style="list-style-type: none"> Dispenser authorizes and price/volume display resets, but no CNG flow present 	<ul style="list-style-type: none"> Manual shut-off valve(s) are closed Filter inlet valve valve(s) are closed Hose nozzle is faulty No gas supply from storage Vehicle fill line valve is closed Low-bank inlet valve is stuck closed Low-bank coil is faulty 	<ul style="list-style-type: none"> Turn manual shut-off valve(s) to open position Turn filter inlet valve(s) to open position Inspect the hose nozzle; ensure it is in proper working condition Inspect gas supply in storage Inspect vehicle fill line valve Rebuild low-bank solenoid valve— contact Tech. Support for more information Rebuild low-bank solenoid valve
<ul style="list-style-type: none"> Price/volume display does not reset upon authorization 	<ul style="list-style-type: none"> Authorization-handle proximity switch is faulty or disconnected Dispenser-POS wire connections are disconnected POS or card-lock system is not allowing authorization, disconnected, or not properly configured POS pump-ID is not set POS-ID is not configured 	<ul style="list-style-type: none"> Inspect the functionality of component—refer to <i>Table 5.4</i> for component voltage statuses. Ensure the POS connections are secure Ensure POS or card-lock system is connected and properly configured Ensure pump-IDs are properly configured see <i>section 3.4</i> of the manual Ensure POS-IDs are properly configured—see <i>section 3.4</i> of the manual

Table 5.3: Troubleshooting (continued)

ISSUE	POSSIBLE CAUSE(S)	RECOMMENDED ACTION
<ul style="list-style-type: none"> Price/volume display resets upon authorization, but does not show any further readings during fuel delivery 	<ul style="list-style-type: none"> Wires are loose or disconnected at mass flow meter or at explosion-proof junction box Mass flow meter is faulty MICON[®]-mainboard is faulty 	<ul style="list-style-type: none"> Ensure all wire connections to the mass flow meter and in the junction box are secure Use Micro Motion[®] ProLink to inspect mass flow meter functionality—contact Tech. Support for more information Replace mainboard—refer to <i>section 4.4</i> of the manual
<ul style="list-style-type: none"> Display stops reading within 5 – 10 seconds of authorization, but CNG continues to flow 	<ul style="list-style-type: none"> Low-bank solenoid valve remains open during temperature compensation target-fill calculation 	<ul style="list-style-type: none"> Rebuild low-bank solenoid valve
<ul style="list-style-type: none"> Dispenser overfills vehicles 	<ul style="list-style-type: none"> MICON[®] parameters are not properly configured Temperature probe is not reading correctly Low-bank solenoid valve is stuck open Pressure transmitter is faulty 	<ul style="list-style-type: none"> Review MICON[®] configurations. You will require for this procedure—contact Tech. Support for more information Compare displayed temperature to actual ambient temperature. If there are discrepancies, contact Tech. Support Rebuild low-bank solenoid valve Replace pressure transmitter—contact Tech. Support for more information
<ul style="list-style-type: none"> Dispenser under-fills vehicles (<i>continues next page</i>) 	<ul style="list-style-type: none"> MICON[®] parameters are not properly configured Temperature probe is not reading correctly 	<ul style="list-style-type: none"> Review MICON[®] configurations - contact Tech. Support for more information Compare displayed temperature to actual ambient temperature. If there are discrepancies, contact Tech. Support for further assistance

5. TROUBLESHOOTING

Table 5.3: Troubleshooting (continued)

ISSUE	POSSIBLE CAUSE(S)	RECOMMENDED ACTION
<ul style="list-style-type: none"> Dispenser under-fills vehicles (<i>continued</i>) 	<ul style="list-style-type: none"> MICON[®] is ending transactions on minimum flow conditions MICON[®] minimum flow set too high Pressure transmitter is faulty 	<ul style="list-style-type: none"> Inspect storage supply; there may not be sufficient fuel to continue transactions Reconfigure MICON[®] parameters. Tech. Support for more information Replace pressure transmitter—contact Tech. Support for more information
<ul style="list-style-type: none"> Pressure gauge does not correspond with vehicle gauge 	<ul style="list-style-type: none"> Pressure transmitter is faulty Faulty vehicle gauge 	<ul style="list-style-type: none"> Replace pressure transmitter—contact Tech. Support for more information Observe the pressure of the dispenser pressure gauge, vehicle pressure gauge, and dispenser pressure transmitter to see where discrepancy is.



Please contact our Technical Support Department at 1-833-264-3835 for any issues not covered in Table 5.3 above.

5.3.1 Voltage statuses

In the event you may need to check the functionality of an electrical component, refer to *Table 5.4* below for the proper voltage readings. If there are any discrepancies between your voltage readings and the ones provided below, it may be the cause of your dispenser issues—please contact our Technical Support Department for further assistance: 1-833-264-3835.

Table 5.4: Voltage Status Table

COMPONENT VOLTAGE STATUS—AUTHORIZATION			
Component	Reading position	Voltage—handle OFF	Voltage—handle ON
• Authorization proximity switch	• n/a	• 5V DC	• 0V DC
COMPONENT VOLTAGE STATUS—PULSE			
Component	Reading position	Voltage	Frequency during fuel delivery
• CNG050 Sensor processor	• 1 to 2	• 24V DC	• n/a
	• 3 to 4	• n/a	• 50 – 200Hz
• Power supply	• Ground to N	• 115 – 120V AC	• n/a
	• Ground to L	• 115 – 120V AC	• n/a
	• V+ to V-	• 24V DC	• n/a

This page intentionally left blank

APPENDIX

A.1 Component descriptions and specifications

Air purge system components

The air purge system for the Retail unit is composed of several components, including a purge fan, Magnehelic pressure gauge, pressure switch, solid-state timer, and relay.

Purge fan

The purge fan is used to pressurize the upper cabinet of the Retail dispenser. The positive air pressure ensures that no methane can enter the electronics cabinet in case of a gas leak.

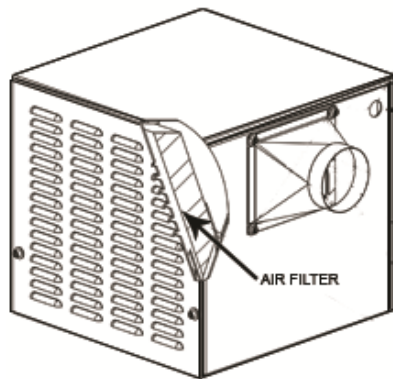

Specifications

HP	1 / 10
Volts	115V
HZ	50 / 60
Amps	1.85 / 2.05
RPM	1320 / 1430
CFM	549 @ Free Air 60HZ

Purge fan ducting—installation guidelines

Depending on site and atmospheric conditions, condensation may form in the ducting from the purge fan to the dispenser cabinet, as well as in the cabinet enclosure itself. This is caused by excessive moisture in the purge air supply.

Since conditions vary from site-to-site, it is not possible to address each unique situation; however, the following guidelines may help to mitigate the effects of condensation buildup. Additional measures beyond these guidelines may be required in certain circumstances.

- Ideally, purge air delivered to the dispenser should be maintained as close as possible to the ambient outdoor air temperature.

Guidelines continue next page

- In most cases, when purge air ducting is buried underground, insulation is required to prevent the purge air reaching its dew point within the duct. Site conditions and expected temperature differential between air and ground will dictate the amount of insulation required.
 - In situations where a moderate difference in outdoor air temperature relative to ground temperature exists, it may be possible to directly bury the purge air ducting without any special preparation.
 - Duct run length also plays a key role in the formation of condensation. The longer the run, the higher the risk of condensation given the increased time for purge air to cool within the ducting. Both temperature differential and run length should be considered together.
 - In some cases it may not be possible to eliminate condensation within the purge air ducting due to site conditions and climate. A common solution is to slope the ducting into a sump pit along its run. Accumulated condensate will run into this pit, which can then be automatically drained via a simple fractional horsepower condensate pump or similar float-controlled pump.
- Local code authorities should be consulted to address any regulatory concerns with the use of an electric pumping apparatus near a classified location.



For all purge fan installation and maintenance concerns, please contact our Technical Support Department at 1-833-264-3835.



Magnehelic pressure gauge

The Dwyer® 2000 Series Pressure Gauge is used to quickly indicate low-air or non-corrosive gas pressures—whether positive, negative or differential—at a high-level of accuracy. The 2000 series is shock, vibration, and overpressure resistant, and operates without manometer fluid, thereby avoiding unnecessary fluid maintenance and any toxicity and leveling problems.

Specifications

Service	Air and non-combustible, compatible gases
Housing	Die cast aluminum case and bezel, with acrylic cover. Exterior finish coated gray to withstand 168 hour salt spray corrosion test
Accuracy	±2% of full scale throughout range at 70°F (21.1°C)
Pressure limits	-20" Hg to 15 psig† ; MP: 35 psig; HP: 80 psig
Overpressure	Relief plug opens at approx. 25 psig (1.72bar). Refer to manufacturer for overpressure protection note.
Temperature limits	20 to 140°F ; -6.67 to 60°C
Size	4" (101.6mm) diameter dial face
Weight (approx.)	3.25 lb (1.5 kg)
Approvals	CE, UL, CSA, FM



Pressure switch

The Dwyer® 1950 Series Pressure Switch operates as the trigger that initiates power to all dispenser-electronics. The pressure switch is located in the lower cabinet and is programmed to detect a specific level of air pressure, which upon detection, delivers a signal to initiate and maintain power to all dispenser-electronics.

Should the air pressure fall below the threshold, the signal is broken and power to all dispenser-electronics is terminated.

Specifications

Service	Air and non-combustible, compatible gases
Temperature limits	-40 to 140°F (-40 to 60°C)
Enclosure rating	NEMA 3 (IP54), NEMA 7 & 9
Switch type	Single-pole double-throw (SPDT)
Electrical rating	15 A @, 125, 250, 480 VAC, 60 Hz. Resistive 1/8 HP @ 125 VAC, 1/4 HP @ 250 VAC, 60 Hz.
Electrical connections	3 screw type, common, normally open and normally closed
Process connections	1/8" female NPT
Weight (approx.)	3.25 lb (1.5 kg)
Approvals	CE, UL, CSA, FM



Pressure timer

The Omron® H3YN Solid-state Timer operates as a precautionary device that ensures sufficient time is allowed for the upper cabinet to become fully pressurized. The timer is located in the explosion-proof junction box in the lower cabinet and receives signals from the pressure switch. After receiving the signal, the timer initiates a minute-and-a-half buffer to allow the upper cabinet to become fully pressurized. Once the buffer time has elapsed, the timer transmits its own signal to a 110/120V AC relay, which sends the signal to the terminal hub in the upper cabinet.

Specifications

	H3YN-2/-4/-4-Z	H3YN-21/-41/-41-Z
Time ranges	0.1s to 10 min (1s; 10s; 1 min; 10 min max)	0.1 min to 10 h (1 min; 10 min; 1h; 10h max)
Operating mode	ON-delay; interval; flicker OFF start; flicker ON start (selectable with DIP switch)	
Accuracy of operating time	±1% FS max. (1 s range: ±1%±10 ms max.)	
Setting error	±10%±50% ms FS max.	
Reset time	Min. power-opening time: 0.1s max. (includes halfway reset)	
Life expectancy	Mechanical: 10,000,000 operation mins. (under no load at 1,800 operations/h) Electrical: DPDT – 500,000 operation mins. (5 A at 250 VAC, resistive load at 1,800 operations/h) 4PDT – 200,000 operation mins. (H3YN-4-Z/-41-Z: 100,000 operation mins.)	
Weight (approx.)	50 g	

Air purge system relay

See *Air purge system/authorization relay*.

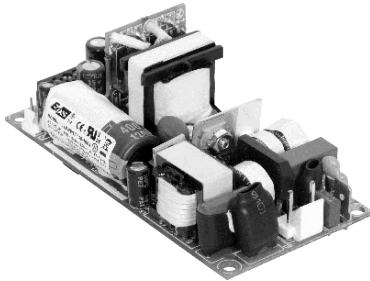

Power supply

The EOS LFWLT150 Series Power Supply provides 24V DC power to the MICON® system and the POS printers. This power supply is located inside the electrical junction box.

Specifications

Output capacity	150W
Input voltage (single-phase, 2-wire)	90 to 264V AC
Input current (max.)	120 VAC – 1.7A
Internal fuse rating	4.0A
Typical efficiency	24V DC—84%
Output current ratings	24V DC—4.17A (convection cooled)
Voltage adjustment	±3% (V. Adjustment control on bottom)
Approvals	EN55022-B, CISPR22-B, FCC PART15 CLASS-B, EN50082-1, EN61000-4-2 Level 3, UL/CSA C22.2 No./IEC/EN60950-1
Weight (approx.)	150 g

Air purge system/authorization relay



The TE Connectivity K10P-11A15-120 and K10P-11D55-24 General-purpose Relay is used for various dispenser applications.

Two 110/120V AC relays are used to receive signals from the pressure timer and transmit signals to the terminal hub, where electrical power is distributed to all dispenser-electronics. These relays are located beside the pressure timer in the lower junction box. They are part of the purge system and are used to control power to the dispenser electronics and heaters.

Two 24V DC relay are used in the upper cabinet to switch the heaters on/off based on the signal from the door mounted thermostats.

Specifications

	110/120V AC	24V DC
Rated current	15A	15A
Coil resistance	3900 Ω	160 Ω
Power consumption	1.35 VA (60Hz)	1.25 VA
Max. operating freq.	Mechanical: 100,000 operations/hr; Electrical: 360 operations/hr (under rated load)	
Approvals	UL E22575; CSA L15734	
Weight (approx.)	51 g	



For further details on dispenser components, please refer to the part manufacturer or contact our Engineering or Technical Support departments 1-833-264-3835.

Micro Motion® CNG050 flow meter

The Micro Motion® CNG050 is a Coriolis mass flow meter designed specifically for measuring CNG. The meter’s refined accuracy and sensitivity allow users the flexibility of using the sensor for standard automobile dispenser configurations or high-flow dispensers for heavy duty fleets.

Flow specifications

	Mass		Standard volume ⁽¹⁾	
	lb/min	kg/min	SCFM	Nm ³ /hr
Flow range	2 to 220	1 to 100	40 to 4444	68 to 7550
Zero stability	0.02	0.009		
Batch accuracy⁽²⁾⁽³⁾	±0.50% of batch			
Repeatability⁽²⁾	±0.30% of rate			

(1) CNG with SG = 0.66 at 60°F (15.5°C) and 14.73 psia (1 bar-a).

(2) In terms of percent of total batch delivered on CNG.

(3) Accuracy is under typical CNG batch/dispensing conditions. Typical batch/dispensing conditions are defined as those where the flow rate is greater than 4lbs/min or 109kg/hr.

Pressure ratings

	psi	bar
Flow tube rating	5,000	345
Pressure limits⁽¹⁾	5,000	345
Union to NPT adapter piece rating⁽²⁾	4,600	317
House rating	Housing is not rated for pressure containment.	
PED compliance	Sensor complies with council directive 97/23/EC of 29-May-1997 on Pressure equipment	

(1) All fittings are rated to 5,000 psi (345 bar) – the Union SWG type fitting according to ASME B31.3, and the SAE fitting according to SAE J1453.

(2) Pressure rating of the additional adapter piece (#12 O-ring face seal to female NPT) that is provided with process connection option 239.

Micro Motion® CNG050 flow meter (continued)

Environmental limits

		°F	°C
Process fluid temp. limits		-40 to +257	-40 to +125
Ambient temp. limits	CSA and MMI standard (no approval) ATEX	-40 to +140	-40 to +60
Humidity limits	5 to 95% relative humidity, non-condensing at 140°F / 60°C		
Vibration limits	Meets IEC 68.2.6, endurance sweep, 5 to 2,000 Hz, 50 sweep cycles at 1.0 g		

Weight

Sensor with core processor	16 lbs / 7 kg
Sensor with integrally mounted transmitter	18 lbs / 8 kg

Materials

Wetted parts ⁽¹⁾	316L stainless steel
Sensor housing	304L stainless steel
Core processor housing	CF-3M stainless steel or polyurethane-painted aluminum; NEMA 4X (IP65)

(1) General corrosion guidelines do not account for cyclical stress and therefore should not be relied upon when choosing a wetted material for your Micro Motion® flow meter. Please refer to Micro Motion's corrosion guide for material compatibility information.



KAF 402™ solenoid inlet valve



The Kraus model KAF 402™ solenoid valve has been specifically engineered for high-pressure CNG service. It is a unique valve that features a high flow rate; a high-pressure rating; a compact design; and low power requirements, meaning that it does not require the assistance of a lifting coil and relay. These features make this panel mount control valve an excellent choice for sequencing or ESD applications in natural gas dispensing systems.

The KAF 402™ series is available in North American (N) and European (E) models. The KAF 402™-N is approved by the CSA, designed to the ASME code, and complies with NFPA 52 and CGA B108 standards. The KAF 402™-E is TÜV and ATEX approved, and complies with European PED standards.

Technical data	(N)	(E)
Operation	2-way solenoid valve, normally closed	
Design pressure	5,000 psi	345 bar
Operating pressure range—TÜV approved values	73 to 5,000 psi	5 to 345 bar
Test pressure	6,000 psi	414 bar
Burst pressure	25,000 psi	1,700 bar
Operating temperature—CSA approved values	-40°F to +150°F	-40°C to +66°C
Operating temperature—TÜV approved values	-40°F to +122°F	-40°C to +50°C
Flow coefficient (Cv)	3.3	
Inlet and outlet ports	SAE-8 (3/4 – 16)	G1/2" ISO228/1
Electrical specifications		
Connection	1/2" NPT (North American)	DIN Cable (European)
Power consumption	10 Watts (average)	
Materials		
Body	7075 Aluminum, Anodized	Seat 304 Stainless Steel
Piston	PEEK	Seals Nitrile

Fueling nozzles

Kraus CNG dispensers are compatible with Type 1 and Type 2 nozzles for use in either NGV1 (passenger vehicles) or NGV2 (large fleet vehicles) refueling applications. The following are some examples of commonly used nozzles; please contact your salesperson or our Technical Support Department for ordering information and other details (1-833-264-3835).

Type 1 nozzle

The Type 1 nozzle incorporates an integrated vent valve that allows for safe venting and detaching in a single motion.



WEH-TK16
Type 1 nozzle for NGV1 applications



OPW CT1000S
Type 1 nozzle for NGV1 applications



WEH-TK17
Type 1 nozzle for NGV1 applications



OPW CT5000S
Type 1 nozzle for NGV2 applications

Type 2 nozzle

The Type 2 nozzle must be coupled with an external vent valve that requires the user to vent the gas before choosing to disconnect the nozzle from the vehicle's receptacle.



Staubli-CMV 08
Type 2 nozzle for NGV1 applications



Oasis FV103-9-000-0
Type 2 fill valve for NGV applications

A.2 Maintenance task list

SCHEDULE	MAINTENANCE TASK
AT STARTUP	<ul style="list-style-type: none"> • Inspect fill hoses and breakaway components • Tighten all electrical terminal connections and check all harness connections • Dispenser leak test
DAILY	<ul style="list-style-type: none"> • Inspect the dispenser and all of its components. If any damages are found, vent, disconnect AC power, and disallow further use until maintenance authority can repair the damages. • Drain dispenser filters
2 WEEKS AFTER STARTUP	<ul style="list-style-type: none"> • Change filter elements—it is common that above normal amounts of debris or liquids from newly installed pressure lines may be present
EVERY 2 WEEKS	<ul style="list-style-type: none"> • Inspect fill nozzle seals for leaks and wear • Inspect flow control or sequencing valves during filling operation • Inspect the sequencing valves for leaks • Inspect fill hoses and hose breakaway components
EVERY 6 MONTHS	<ul style="list-style-type: none"> • Change dispenser filters • Dispenser leak test • Visual leak inspection of pressure relief device—if internal leakage has occurred there will be visible frosting on the outlet tubing
EVERY YEAR	<ul style="list-style-type: none"> • Tighten all electrical terminal connections and check all harness connections • Rebuild sequencing valve • Inspect fill nozzle valve, rebuild if necessary • Inspect pressure regulator, rebuild if necessary
EVERY 2 YEARS	<ul style="list-style-type: none"> • Replace fill hose
EVERY 5 YEARS	<ul style="list-style-type: none"> • Recertify pressure relief device

GLOSSARY

B

Bar. A metric unit of pressure; 1 bar = 14.5038 psi

Breakaway. A fuel dispenser-hose feature that allows the hose to break apart and cease gas flow in the event that a vehicle drives away while the nozzle is still connected to the vehicle's receptacle.

Buffer storage system. A fuel storage system consisting of a single large storage bank, generally used, but not limited to, large vehicles, such as buses and trucks.

C

Card-lock system. A security system incorporated into a dispenser to prevent unauthorized used. Fleet/fuel cards are required to authorize a refueling transaction.

Cascade storage system. A fuel storage system consisting of two or three storage banks pressurized at different levels. The storage banks are used sequentially in a pre-determined sequence.

CNG. Compressed Natural Gas; an environmentally friendly fuel alternative to petrol (gasoline), diesel, and propane

CNG050. A mass-flow meter consisting of transmitters and sensors designed to measure CNG flow, manufactured by Micro Motion®.

Coalescing filtration. A filtration method that separates water aerosols and droplets, as well as solid particles, from gases; the standard and recommended method of filtration for all Kraus CNG dispensers

Communicator. A standard MICON® remote used to set dispenser prices and check totalizer readings (may not be apply to Retail dispensers).

E

ESD. Emergency Shut-Down; a safety feature that allows users to terminate all power and gas flow to immediate fuel dispensers—ESD buttons are not standard features, but Kraus CNG dispensers are equipped with ESD terminals that can enable this function.

H

High-flow dispenser. A CNG filling system designed to quickly refuel vehicles

I

K

KAF 402™. A Kraus-original solenoid valve, engineered specifically for high-pressure CNG applications; see also *Solenoid valve*.

M

Mainboard. A circuit-board housing vital electrical components, such as the CPU

MICON NEXTGEN 1.0®. A ComTech Energy-manufactured pump-controller

O

O-ring. A small, circular elastic joint used to seal or fill space between mating components.

P

Particulate filtration. A filtration method designed to remove solid particles from gases.

PLC. Programmable Logic Controller; a computer used to automate electromechanical processes, such as dispensers and assembly lines.

POS system. Point-Of-Sale system; a retail system that allows fuel station attendants to control and authorize fuel dispensers from their terminal. Also includes a user interface that incorporates a card reader, keypad, and screen display that allows customers to make retail transactions at the dispenser.

Positive pressure. An air pressure greater than that of its surrounding environment; used as an engineering technique to isolate an area from outside contaminants

Pressure vessel. A sealed container designed to hold gases or liquids at a considerably higher pressure than that of the ambient atmosphere.

PSI. Pound-force per Square Inch; a unit of pressure

Pump-controller. An electronic device used to control the voltage supplied to the fuel-pump and other signals used within the fuel-pump.

Pump door node. A circuit-board located on the reverse side of the upper cabinet door of the Retail dispenser, consisting of components affecting the dispenser display electronics.

R

Rebuild kit. A ComTech Energy package including parts and instructions necessary to rebuild a dispenser component, such as a solenoid valve; sold separately from dispenser packages

S

SAE J1616. A standard developed by SAE International that describes recommended practices for using compressed natural gas as fuel for vehicles.

Solenoid valve. An electromechanically controlled valve; for CNG dispensers, it is used to control gas flow from the storage banks to a vehicle receptacle.

Split-flow. A single fuel dispenser with one hose designed for a standard-flow filling system and another designed for a high-flow filling system.

Split-pressure. A single fuel dispenser designed to dispense fuel at two different pressure options.

Standard-flow dispenser. A CNG filling system designed to refuel passenger vehicles.

T

Totalizer. A function within the MICON NEXTGEN 1.0® that sums up the total dollar and volume sales.

INDEX

<p>#</p> <hr/> <p>2-wire, 24</p>	<p>L</p> <hr/> <p>lockout, 24</p>
<p>A</p> <hr/> <p>anchor, 16</p>	<p>M</p> <hr/> <p>menu Diagnostic Startup Menu, 27 MICON NEXTGEN 1.0®, 4, <i>see</i> MICON® MICON®, 35; 38</p>
<p>B</p> <hr/> <p>breakaway, 14, 21</p>	<p>N</p> <hr/> <p>notifications, 3</p>
<p>C</p> <hr/> <p>connection communication, 17 electrical, 8, 17, Appendix-2 pressure line, 17 convey, 10</p>	<p>P</p> <hr/> <p>pit frame, 14, 16 pump door node, 24, 26 purge fan, 22, 37, Appendix-1 Purpose, 1</p>
<p>D</p> <hr/> <p>diagnostic card, 27</p>	<p>S</p> <hr/> <p>SAE J1616, 13 screw thread, 16 storage system(s) buffer, 5 cascade, 5, 23</p>
<p>F</p> <hr/> <p>filters Coalescing, 18 installation, 19 KAF 402™ solenoid valve, 36 maintenance, 32 Particulate, 18 placement, 18 purge fan, 37 size, 18</p>	<p>U</p> <hr/> <p>users, 1; Appendix-5</p>
<p>G</p> <hr/> <p>gauge Magenhelic, 22, 37, Appendix-1 pressure, 22, 23, 33 grounded, 10</p>	<p>V</p> <hr/> <p>voltage, 40, 41, 43</p>
<p>I</p> <hr/> <p>Intended users, <i>see</i> users</p>	<p>W</p> <hr/> <p>warnings, 3 warranty, 3, 28</p>
<p>K</p> <hr/> <p>keys, 15, 24, 35</p>	

This page intentionally left blank

ComTech Energy

©2021 Compression Technology Corporation
All Rights Reserved

Printed in Canada