

Cub Cadet.

OPERATOR'S MANUAL

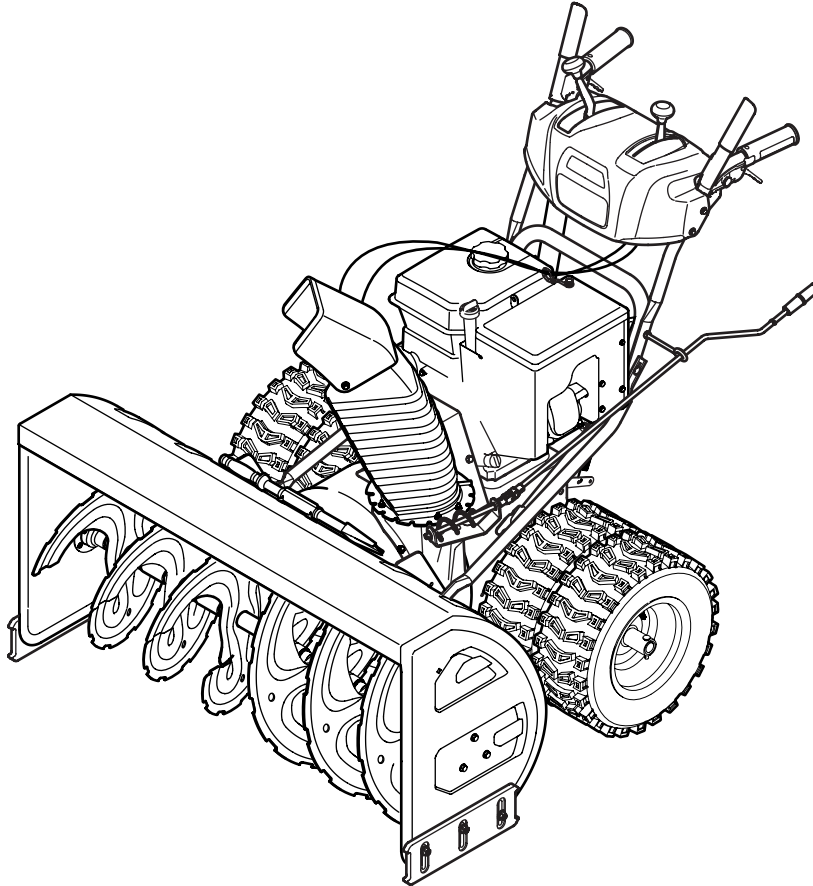

Two Stage Snow Thrower — Model 945 SWE

⚠ WARNING

**READ AND FOLLOW ALL SAFETY RULES AND INSTRUCTIONS IN THIS MANUAL
BEFORE ATTEMPTING TO OPERATE THIS MACHINE.
FAILURE TO COMPLY WITH THESE INSTRUCTIONS MAY RESULT IN PERSONAL INJURY.**

CUB CADET LLC, P.O. BOX 361131 CLEVELAND, OHIO 44136-0019

Thank You

Thank you for purchasing a Snow Thrower manufactured by Cub Cadet LLC. It was carefully engineered to provide excellent performance when properly operated and maintained.

Please read this entire manual prior to operating the equipment. It instructs you how to safely and easily set up, operate and maintain your machine. Please be sure that you, and any other persons who will operate the machine, carefully follow the recommended safety practices at all times. Failure to do so could result in personal injury or property damage.

All information in this manual is relative to the most recent product information available at the time of printing. Review this manual frequently to familiarize yourself with the unit, its features and operation. Please be aware that this Operator's Manual may cover a range of product specifications for various models. Characteristics and features discussed and/or illustrated in this manual may not be applicable to all models. Cub Cadet LLC reserves the right to change product specifications, designs and equipment without notice and without incurring obligation.

If you have any problems or questions concerning the unit, phone your local Cub Cadet dealer or contact us directly. Cub Cadet's Customer Support telephone numbers, website address and mailing address can be found on this page. We want to ensure your complete satisfaction at all times.

Throughout this manual, all references to *right* and *left* side of the machine are observed from the operating position

The engine manufacturer is responsible for all engine-related issues with regards to performance, power-rating, specifications, warranty and service. Please refer to the engine manufacturer's Owner's/Operator's Manual, packed separately with your unit, for more information.

Table of Contents

Important Safe Operation Practices	3	Service	17
Assembly & Set-Up	7	Troubleshooting	21
Controls and Features	11	Replacement Parts	22
Operation	13	Attachments & Accessories	23
Maintenance & Adjustment	14	Warranty	Back Cover

Record Product Information

Before setting up and operating your new equipment, please locate the model plate on the equipment and record the information in the provided area to the right. You can locate the model plate by standing at the operator's position and looking at the lower, rear section of the frame. This information will be necessary, should you seek technical support via our web site, Customer Support Department, or with a local authorized service dealer.

MODEL NUMBER

--	--	--	--	--	--	--	--	--	--	--	--

SERIAL NUMBER

--	--	--	--	--	--	--	--	--	--	--	--

Customer Support

If you have difficulty assembling this product or have any questions regarding the controls, operation, or maintenance of this unit, you can seek help from the experts. Choose from the options below:

- ◇ Visit us on the web at www.cubcadet.com
- ◇ Locate your nearest Cub Cadet Dealer at (877) 282-8684
- ◇ Write us at Cub Cadet LLC • P.O. Box 361131 • Cleveland, OH • 44136-0019



WARNING! This symbol points out important safety instructions which, if not followed, could endanger the personal safety and/or property of yourself and others. Read and follow all instructions in this manual before attempting to operate this machine. Failure to comply with these instructions may result in personal injury.

When you see this symbol. **HEED ITS WARNING!**

CALIFORNIA PROPOSITION 65



WARNING! Engine Exhaust, some of its constituents, and certain vehicle components contain or emit chemicals known to State of California to cause cancer and birth defects or other reproductive harm.



DANGER: This machine was built to be operated according to the safe operation practices in this manual. As with any type of power equipment, carelessness or error on the part of the operator can result in serious injury. This machine is capable of amputating fingers, hands, toes and feet and throwing foreign objects. Failure to observe the following safety instructions could result in serious injury or death.

Training

1. Read, understand, and follow all instructions on the machine and in the manual(s) before attempting to assemble and operate. Keep this manual in a safe place for future and regular reference and for ordering replacement parts.
2. Be familiar with all controls and their proper operation. Know how to stop the machine and disengage them quickly.
3. Never allow children under 14 years of age to operate this machine. Children 14 and over should read and understand the instructions and safe operation practices in this manual and on the machine and be trained and supervised by an adult.
4. Never allow adults to operate this machine without proper instruction.
5. Thrown objects can cause serious personal injury. Plan your snow-throwing pattern to avoid discharge of material toward roads, bystanders and the like.
6. Keep bystanders, pets and children at least 75 feet from the machine while it is in operation. Stop machine if anyone enters the area.
7. Exercise caution to avoid slipping or falling, especially when operating in reverse.

Preparation

Thoroughly inspect the area where the equipment is to be used. Remove all doormats, newspapers, sleds, boards, wires and other foreign objects, which could be tripped over or thrown by the auger/impeller.

1. Always wear safety glasses or eye shields during operation and while performing an adjustment or repair to protect your eyes. Thrown objects which ricochet can cause serious injury to the eyes.
2. Do not operate without wearing adequate winter outer garments. Do not wear jewelry, long scarves or other loose clothing, which could become entangled in moving parts. Wear footwear which will improve footing on slippery surfaces.
3. Use a grounded three-wire extension cord and receptacle for all machines with electric start engines.
4. Adjust auger housing height to clear gravel or crushed rock surfaces.
5. Disengage all control levers before starting the engine.
6. Never attempt to make any adjustments while engine is running, except where specifically recommended in the operator's manual.
7. Let engine and machine adjust to outdoor temperature before starting to clear snow.

Safe Handling of Gasoline

To avoid personal injury or property damage use extreme care in handling gasoline. Gasoline is extremely flammable and the vapors are explosive. Serious personal injury can occur when gasoline is spilled on yourself or your clothes which can ignite. Wash your skin and change clothes immediately.

- a. Use only an approved gasoline container.
- b. Extinguish all cigarettes, cigars, pipes and other sources of ignition.
- c. Never fuel machine indoors.
- d. Never remove gas cap or add fuel while the engine is hot or running.
- e. Allow engine to cool at least two minutes before refueling.
- f. Never over fill fuel tank. Fill tank to no more than ½ inch below bottom of filler neck to provide space for fuel expansion.
- g. Replace gasoline cap and tighten securely.
- h. If gasoline is spilled, wipe it off the engine and equipment. Move machine to another area. Wait 5 minutes before starting the engine.
- i. Never store the machine or fuel container inside where there is an open flame, spark or pilot light (e.g. furnace, water heater, space heater, clothes dryer etc.).
- j. Allow machine to cool at least 5 minutes before storing.
- k. Never fill containers inside a vehicle or on a truck or trailer bed with a plastic liner. Always place containers on the ground away from your vehicle before filling.
- l. If possible, remove gas-powered equipment from the truck or trailer and refuel it on the ground. If this is not possible, then refuel such equipment on a trailer with a portable container, rather than from a gasoline dispenser nozzle.
- m. Keep the nozzle in contact with the rim of the fuel tank or container opening at all times until fueling is complete. Do not use a nozzle lock-open device.

Operation

1. Do not put hands or feet near rotating parts, in the auger/impeller housing or chute assembly. Contact with the rotating parts can amputate hands and feet.
2. The auger/impeller control lever is a safety device. Never bypass its operation. Doing so makes the machine unsafe and may cause personal injury.
3. The control levers must operate easily in both directions and automatically return to the disengaged position when released.
4. Never operate with a missing or damaged chute assembly. Keep all safety devices in place and working.
5. Never run an engine indoors or in a poorly ventilated area. Engine exhaust contains carbon monoxide, an odorless and deadly gas.
6. Do not operate machine while under the influence of alcohol or drugs.
7. Muffler and engine become hot and can cause a burn. Do not touch. Keep children away.
8. Exercise extreme caution when operating on or crossing gravel surfaces. Stay alert for hidden hazards or traffic.
9. Exercise caution when changing direction and while operating on slopes.
10. Plan your snow-throwing pattern to avoid discharge towards windows, walls, cars etc. Thus, avoiding possible property damage or personal injury caused by a ricochet.
11. Never direct discharge at children, bystanders and pets or allow anyone in front of the machine.
12. Do not overload machine capacity by attempting to clear snow at too fast of a rate.
13. Never operate this machine without good visibility or light. Always be sure of your footing and keep a firm hold on the handles. Walk, never run.
14. Disengage power to the auger/impeller when transporting or not in use.
15. Never operate machine at high transport speeds on slippery surfaces. Look down and behind and use care when backing up.
16. If the machine should start to vibrate abnormally, stop the engine, disconnect the spark plug wire and ground it against the engine. Inspect thoroughly for damage. Repair any damage before starting and operating.
17. Disengage all control levers and stop engine before you leave the operating position (behind the handles). Wait until the auger/impeller comes to a complete stop before unclogging the chute assembly, making any adjustments, or inspections.
18. Never put your hand in the discharge or collector openings. Always use the clean-out tool provided to unclog the discharge opening. Do not unclog chute assembly while engine is running. Shut off engine and remain behind handles until all moving parts have stopped before unclogging.
19. Use only attachments and accessories approved by the manufacturer (e.g. wheel weights, tire chains, cabs etc.).
20. When starting engine, pull cord slowly until resistance is felt, then pull rapidly. Rapid retraction of starter cord (kickback) will pull hand and arm toward engine faster than you can let go. Broken bones, fractures, bruises or sprains could result.
21. If situations occur which are not covered in this manual, use care and good judgment. Contact Customer Support for assistance and the name of your nearest servicing dealer.

Clearing a Clogged Discharge Chute

Hand contact with the rotating impeller inside the discharge chute is the most common cause of injury associated with snow throwers. Never use your hand to clean out the discharge chute.

To clear the chute:

1. SHUT THE ENGINE OFF!
2. Wait 10 seconds to be sure the impeller blades have stopped rotating.
3. Always use a clean-out tool, not your hands.

Maintenance & Storage

1. Never tamper with safety devices. Check their proper operation regularly. Refer to the maintenance and adjustment sections of this manual.
2. Before cleaning, repairing, or inspecting machine disengage all control levers and stop the engine. Wait until the auger/impeller come to a complete stop. Disconnect the spark plug wire and ground against the engine to prevent unintended starting.
3. Check bolts and screws for proper tightness at frequent intervals to keep the machine in safe working condition. Also, visually inspect machine for any damage.
4. Do not change the engine governor setting or over-speed the engine. The governor controls the maximum safe operating speed of the engine.
5. Snow thrower shave plates and skid shoes are subject to wear and damage. For your safety protection, frequently check all components and replace with original equipment manufacturer's (OEM) parts only. "Use of parts which do not meet the original equipment specifications may lead to improper performance and compromise safety!"
6. Check control levers periodically to verify they engage and disengage properly and adjust, if necessary. Refer to the adjustment section in this operator's manual for instructions.
7. Maintain or replace safety and instruction labels, as necessary.
8. Observe proper disposal laws and regulations for gas, oil, etc. to protect the environment.
9. Prior to storing, run machine a few minutes to clear snow from machine and prevent freeze up of auger/impeller.
10. Never store the machine or fuel container inside where there is an open flame, spark or pilot light such as a water heater, furnace, clothes dryer etc.
11. Always refer to the operator's manual for proper instructions on off-season storage.
12. Check fuel line, tank, cap, and fittings frequently for cracks or leaks. Replace if necessary.
13. Do not crank engine with spark plug removed.

14. According to the Consumer Products Safety Commission (CPSC) and the U.S. Environmental Protection Agency (EPA), this product has an *Average Useful Life* of seven (7) years, or 60 hours of operation. At the end of the *Average Useful Life* have the machine inspected annually by an authorized service dealer to ensure that all mechanical and safety systems are working properly and not worn excessively. Failure to do so can result in accidents, injuries or death.

Do not modify engine

To avoid serious injury or death, do not modify engine in any way. Tampering with the governor setting can lead to a runaway engine and cause it to operate at unsafe speeds. Never tamper with factory setting of engine governor.

Notice Regarding Emissions

Engines which are certified to comply with California and federal EPA emission regulations for SORE (Small Off Road Equipment) are certified to operate on regular unleaded gasoline, and may include the following emission control systems: Engine Modification (EM), Oxidizing Catalyst (OC), Secondary Air Injection (SAI) and Three Way Catalyst (TWC) if so equipped.

Spark Arrestor











WARNING! This machine is equipped with an internal combustion engine and should not be used on or near any unimproved forest-covered, brush covered or grass-covered land unless the engine's exhaust system is equipped with a spark arrestor meeting applicable local or state laws (if any).

If a spark arrestor is used, it should be maintained in effective working order by the operator. In the State of California the above is required by law (Section 4442 of the California Public Resources Code). Other states may have similar laws. Federal laws apply on federal lands.

A spark arrestor for the muffler is available through your nearest engine authorized service dealer or contact the service department, P.O. Box 361131 Cleveland, Ohio 44136-0019.

Safety Symbols

This page depicts and describes safety symbols that may appear on this product. Read, understand, and follow all instructions on the machine before attempting to assemble and operate.

Symbol	Description
	READ THE OPERATOR'S MANUAL(S) Read, understand, and follow all instructions in the manual(s) before attempting to assemble and operate
	WARNING— ROTATING BLADES Keep hands out of inlet and discharge openings while machine is running. There are rotating blades inside
	WARNING— ROTATING BLADES Keep hands out of inlet and discharge openings while machine is running. There are rotating blades inside
	WARNING— ROTATING AUGER Do not put hands or feet near rotating parts, in the auger/impeller housing or chute assembly. Contact with the rotating parts can amputate hands and feet.
	WARNING—THROWN OBJECTS This machine may pick up and throw objects which can cause serious personal injury.
	WARNING—GASOLINE IS FLAMMABLE Allow the engine to cool at least two minutes before refueling.
	WARNING— CARBON MONOXIDE Never run an engine indoors or in a poorly ventilated area. Engine exhaust contains carbon monoxide, an odorless and deadly gas.
	WARNING— ELECTRICAL SHOCK Do not use the engine's electric starter in the rain
	WARNING— HOT SURFACE Engine parts, especially the muffler, become extremely hot during operation. Allow engine and muffler to cool before touching.



WARNING! Your Responsibility—Restrict the use of this power machine to persons who read, understand and follow the warnings and instructions in this manual and on the machine.

SAVE THESE INSTRUCTIONS!

Contents of Carton

- One Snow Thrower
- One Snow Thrower Operator's Manual
- Two Replacement Auger Shear Pins
- One Product Registration Card
- One Chute Assembly

Assembly

IMPORTANT: Two replacement auger shear pins are included with this manual (or stowed in the plastic handle panel). Refer to the Maintenance section for more information regarding shear pin replacement.

NOTE: All references in this manual to the left or right side of the snow thrower is from the operating position only. Exceptions, if any, will be specified.

IMPORTANT: This unit is shipped with the engine full of oil. After assembly, refer to the separate Engine Owner's Manual included with this unit for fuel and oil fill-up details.

NOTE: Specifications are subject to change without notification or obligation. Images may not reflect your exact model and are for reference purposes only.

Handle

1. Remove any packaging material from the upper handle.
2. Remove the lower wing nut, Belleville washer and carriage bolt from each side of the upper handle, as seen in Fig. 3-1.

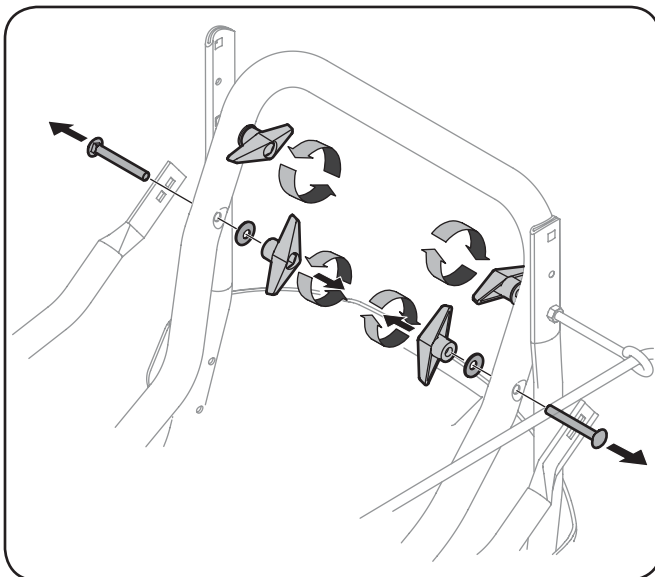

Figure 3-1

3. Raise the upper handle assembly until it snaps over the lower handle. See Fig. 3-2.

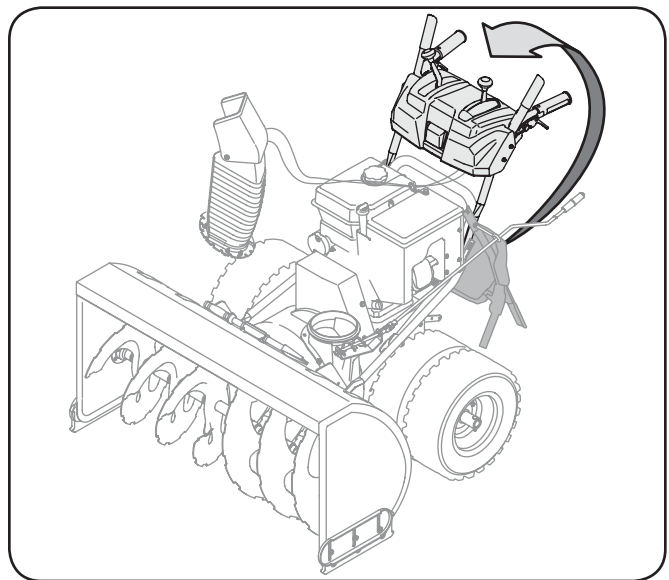

Figure 3-2

4. Looking beneath the handle panel, check that all of the cables (steering, auger, and drive) are properly routed and not pinched or kinked. Make certain the springs at the lower end of the auger and drive cables are securely hooked into their respective actuator bracket. See Fig. 3-11.
5. Secure the upper handle, support tubes and lower handle with the two wing nuts and carriage bolts removed earlier. Tighten the two wing nuts already installed in the upper holes to firmly secure the upper handle and support tubes. See Fig. 3-3.

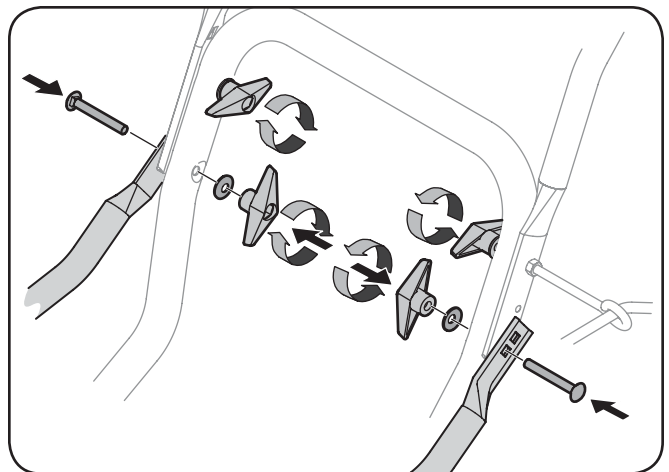

Figure 3-3

Chute Directional Control

1. Remove the hairpin clip from the spiral control as shown in A of Fig. 3-4.
2. Insert the chute directional control rod into the fitting on the spiral control as seen in B of Fig. 3-4.
3. Secure with the hairpin clip previously removed.

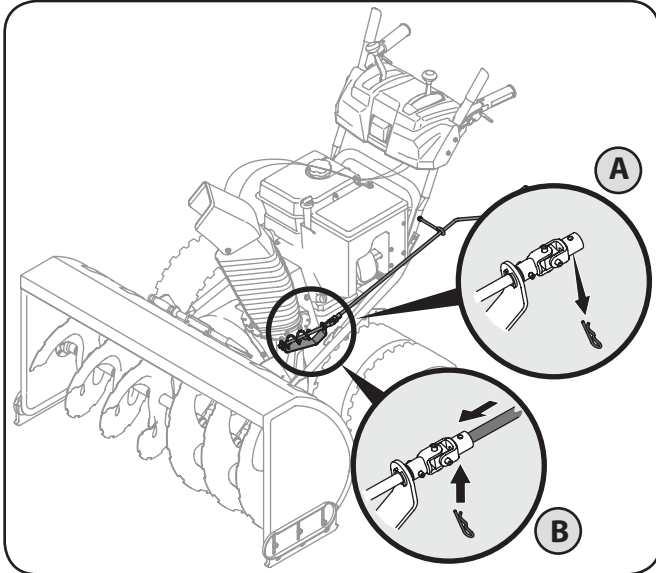

Figure 3-4

Chute Assembly

1. Remove lock nuts and screws securing one of the flange keepers to the chute assembly. Loosen the fasteners of the other two flange keepers. See Fig. 3-5.
2. Place chute assembly onto chute base as shown in Fig. 3-6. Make sure that the chute notches engage with the spiral end of chute directional control, and the two flange keepers are beneath the flange on the chute base.

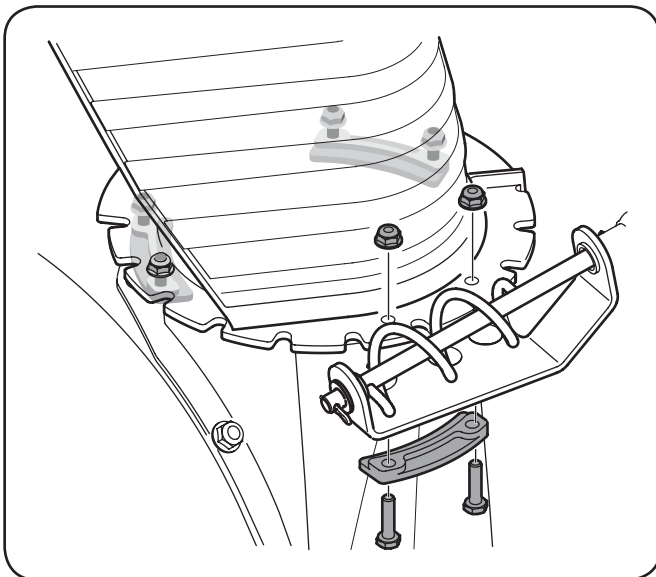

Figure 3-5

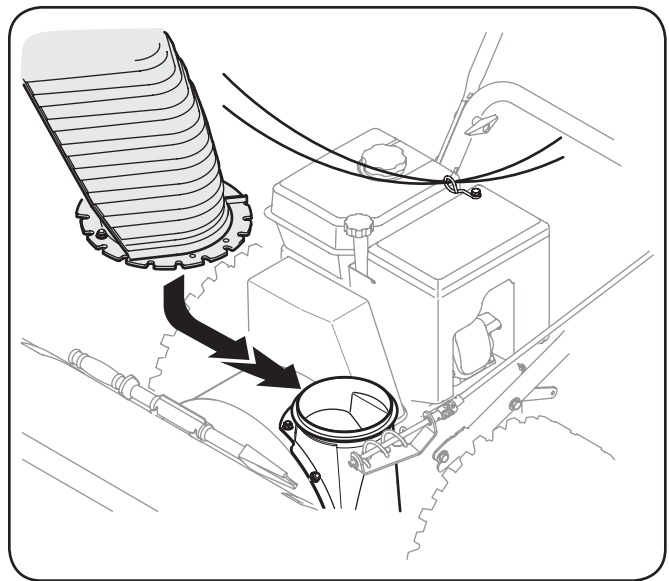

Figure 3-6

4. Secure flange keeper removed earlier with lock nuts and screws. Tighten down nuts securing the other two flange keepers. See Fig. 3-5.
5. Check that the chute cables are properly routed through the cable guide attached to the lower handle assembly. See Fig. 3-6.

Set-Up

Shear Pins

A pair of replacement auger shear pins and bow tie cotter pins have been included with your snow thrower. There are holes provided in the plastic dash panel for convenient storage of the shear pins. Push the pins through the holes in the dash panel and secure with the bow-tie cotter pins. See Fig. 3-7.

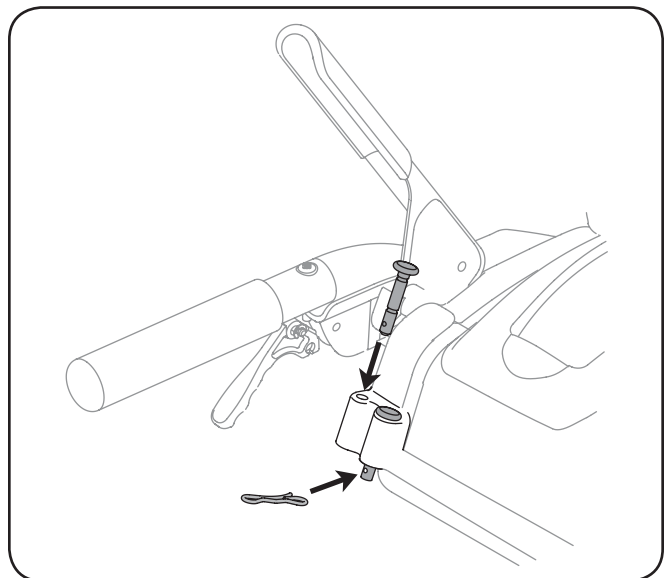

Figure 3-7

Chute Clean-Out Tool

The chute clean-out tool is fastened to the top of the auger housing with a mounting clip and a cable tie at the factory. Cut the cable tie before operating the snow thrower. See Fig. 3-8.

3.

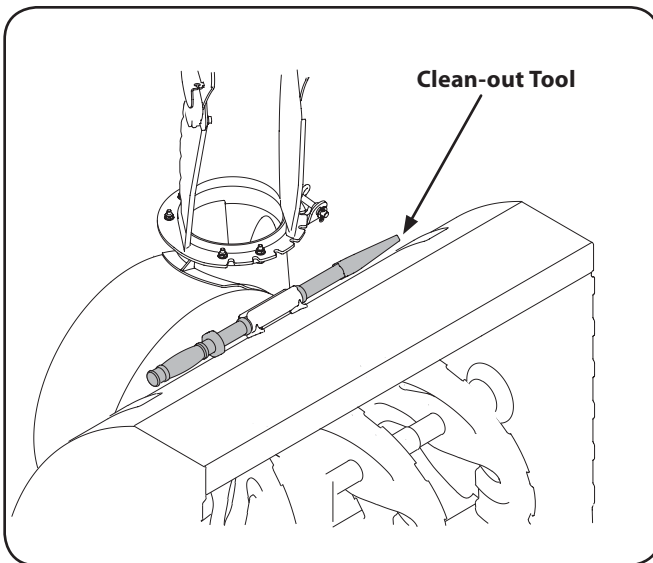

Figure 3-8

Tire Pressure



WARNING: Under any circumstance do not exceed manufacturer's recommended psi. Equal tire pressure should be maintained at all times. Excessive pressure when seating beads may cause tire/rim assembly to burst with force sufficient to cause serious injury. Refer to sidewall of tire for recommended pressure.

The tires are over-inflated for shipping purposes. Check the tire pressure before operating the snow thrower. Refer to the tire side wall for tire manufacturer's recommended psi and deflate (or inflate) the tires as necessary.

NOTE: Equal tire pressure is to be maintained at all times for performance purposes.

Adjustments

Skid Shoes

The snow thrower skid shoes are adjusted upward at the factory for shipping purposes. Adjust them downward prior to operating the snow thrower.



CAUTION: It is not recommended that you operate this snow thrower on gravel as it can easily pick up and throw loose gravel, causing personal injury or damage to the snow thrower and surrounding property.

For close snow removal on a smooth surface, adjust the skid shoes so that the shave plate on the bottom of the auger housing is just off the ground.

Adjust the skid shoes to a lower position to raise the shave plate off the ground when clearing uneven areas, such as a ribbon type driveway or a gravel driveway

NOTE: If you choose to operate the snow thrower on a gravel surface, keep the skid shoes in position for maximum clearance between the ground and the shave plate.



CAUTION: Operating a snow thrower equipped with steel skid shoes may result in damage to natural stone paver surfaces (e.g. sandstone, bluestone, limestone). Refer to the Replacement

Parts or Attachments & Accessories sections for information on available polymer skid shoes.

To adjust the skid shoes:

1. Adjust skid shoes by loosening the six (three on each side) hex nuts, washers, and carriage bolts securing the skid shoes to the auger housing. Refer to Fig. 3-9.
2. While observing the distance between the shave plate and the ground, adjust the skid shoes up or down to achieve the desired shave plate height. See Fig. 3-9.
3. Make certain the entire bottom surface of skid shoes are against the ground to avoid uneven wear on the skid shoes; then tighten nuts and bolts securely.

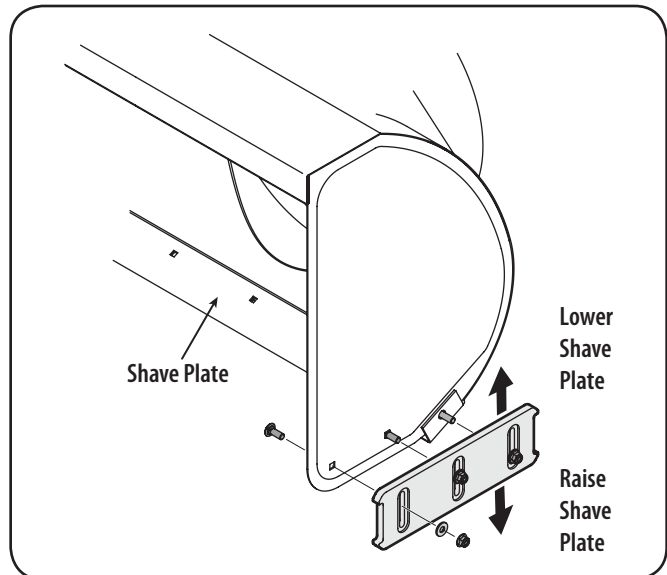

Figure 3-9

Auger and Drive Control Cables



WARNING! Prior to operating your snow thrower, carefully read and follow all instructions below. Perform all adjustments to verify your snow thrower is operating safely and properly.

Testing Auger Drive Control

When the auger control is released and in the disengaged "up" position, the cable should have very little slack. It should NOT be tight. Refer to Fig. 3-10.

1. In a well-ventilated area, start the snow thrower engine as instructed in the engine operator's manual.
2. While standing in the operator's position (behind the snow thrower), engage the auger.
3. Allow the auger to remain engaged for approximately ten (10) seconds before releasing the auger control. Repeat this several times.
4. With the auger control in the disengaged "up" position, walk to the front of the machine.
5. Confirm that the auger has completely stopped rotating and shows NO signs of motion. If the auger shows ANY signs of rotating, immediately return to the operator's position and shut off the engine. Wait for ALL moving parts to stop before re-adjusting the auger control.

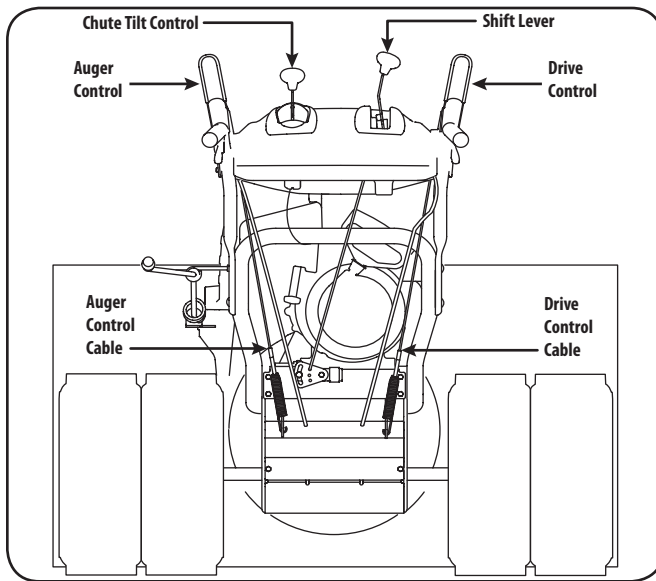

Figure 3-10

NOTE: If the cable requires adjustment, refer to the instructions for **Adjusting Drive and Auger Controls** later in this section.

Testing Drive Control & Shift Lever

1. With the engine turned off, move the shift lever into sixth (6) position. Refer to Fig. 3-10.
2. With the wheel drive control released, push the snow thrower forward, then pull it back. The machine should move freely.
3. Engage the drive control and attempt to move the machine both forward and back, resistance should be felt.
4. Move the shift lever into the fast reverse (R2) position and repeat the previous two steps.
5. If you experienced resistance rolling the unit, either when repositioning the shift lever from 6 to R2 or when attempting to move the machine with the drive control released, adjust the drive control immediately. See **Adjusting Drive and Auger Controls**.

Adjusting Drive and Auger Controls

1. From beneath the handle, pull downward on the appropriate cable and unhook the spring found on the end of the cable from its respective actuator bracket. Refer to Fig. 3-10 and 3-11.
2. Slide the spring up the cable to expose the cable coupler threads and lock nut. Refer to Fig. 3-12.
3. Adjust the lock nut as follows: If adjusting the drive cable, thread the lock nut outward (down the coupler) to lengthen the cable and allow the unit to move freely when the control is released. Thread the lock nut inward (up the coupler) to shorten the cable to reduce slippage and prevent the machine from being easily moved with the drive control engaged.



WARNING! Do not over-tighten the cable. Over-tightening may prevent the auger from disengaging and compromise the safety of the snow thrower.

4. If adjusting the auger cable, thread the lock nut down to lengthen the cable as necessary to stop the auger from turning when the control is released.
5. Securely hook the cable's spring into the rear most hole of the respective actuator bracket.
6. Repeat the wheel drive and auger control tests to verify proper adjustment. Repeat previous steps if necessary to attain proper adjustment of each cable.

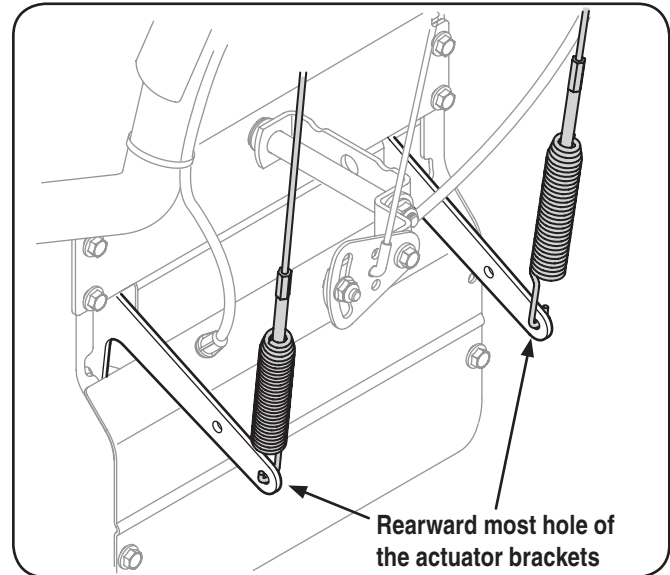

Figure 3-11

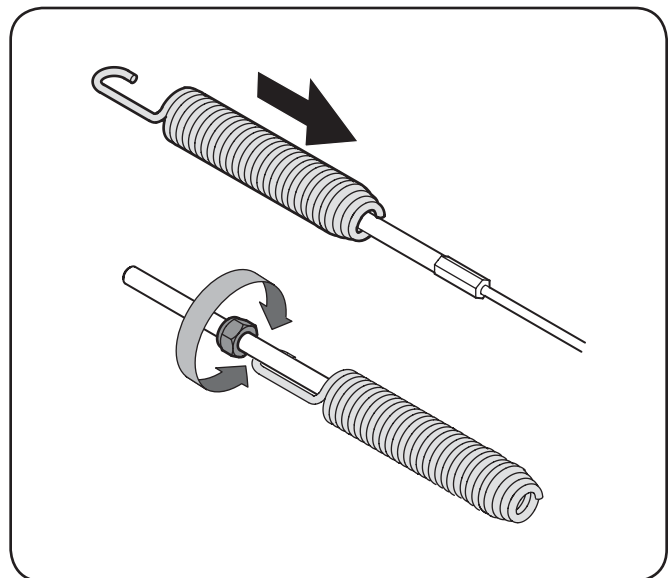

Figure 3-12

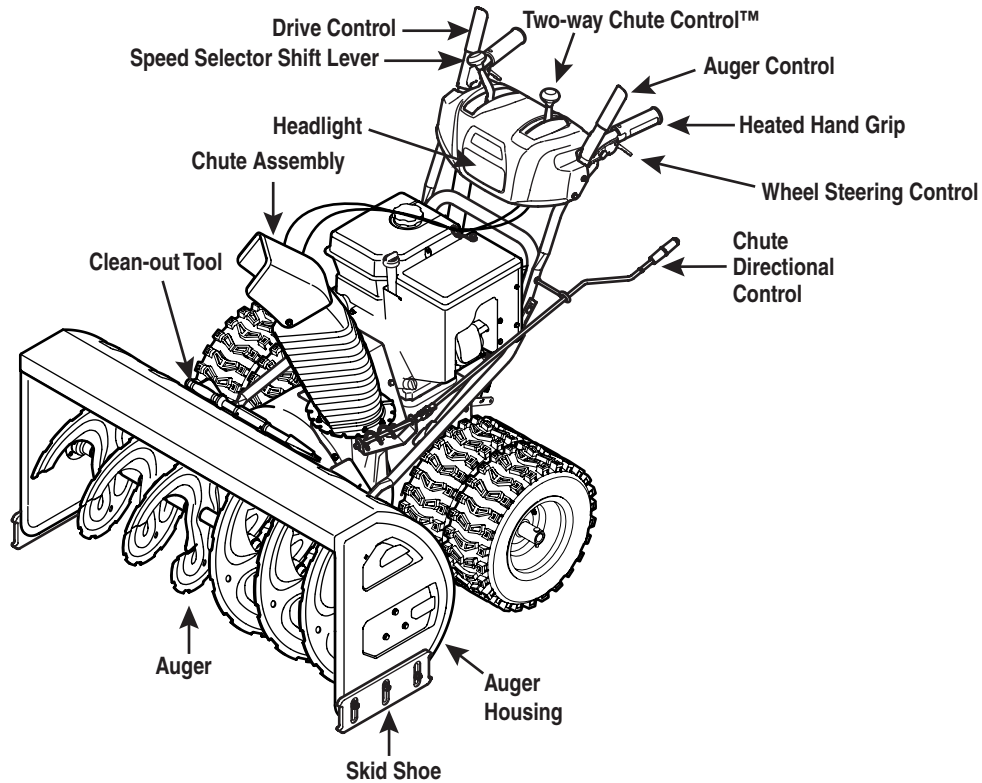

Figure 4-1

Snow thrower controls and features are described below and illustrated in Fig. 4-1.

NOTE: For detailed information on all engine controls, refer to the separate Engine Operator's Manual supplied with this unit.

Speed Selector Shift Lever

The speed selector shift lever is located in the right side of the handle panel and is used to determine ground speed and direction of travel.

Forward

There are six forward (F) speeds. Position one (1) is the slowest and position six (6) is the fastest.

Reverse

There are two reverse (R) speeds. One (1) is the slower and two (2) is the faster.

Heated Hand Grips

Can be turned on/off by a switch found on the dash panel.

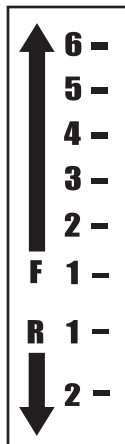

Skid Shoes

Position the skid shoes based on surface conditions. Adjust upward for hard-packed snow. Adjust downward when operating on gravel or crushed rock surfaces.

Augers

When engaged, the augers rotate and draw snow into the auger housing.

Chute Assembly

Snow drawn into the auger housing is discharged out the chute assembly.

Headlight

The headlight is located on the front of the handle panel.

Auger Control

The auger control is located on the left handle. Squeeze the control grip against the handle to engage the augers and start snow throwing action. Release to stop.

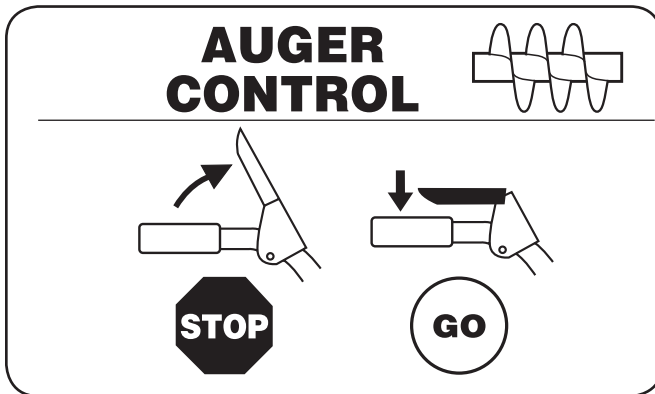

Drive Control / Auger Clutch Lock

The drive control is located on the right handle. Squeeze the control grip against the handle to engage the wheel drive. Release the handle to stop.

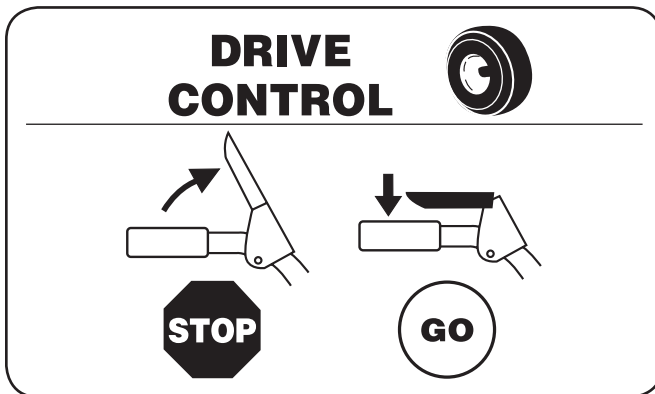

The drive control also locks the auger control so that you can operate the chute directional control without interrupting the snow throwing process. If the auger control is engaged simultaneously with the drive control, the operator can release the auger control (on the left handle) and the augers will remain engaged. Release both controls to stop the augers and wheel drive.

NOTE: Always release the drive control before changing speeds. Failure to do so will result in increased wear on your machine's drive system.

Two-Way Chute Control™

The two-way chute control is located on the left side of the dash panel and is used to control the distance of snow discharge from the chute.

- To change the upper chute angle to control the distance that snow is thrown, pivot the lever forward or backward.
- Move the lever forward to pivot the upper chute down and reduce the distance snow is thrown.
- Move the lever rearward to pivot the upper chute upward and increase the distance snow is thrown.

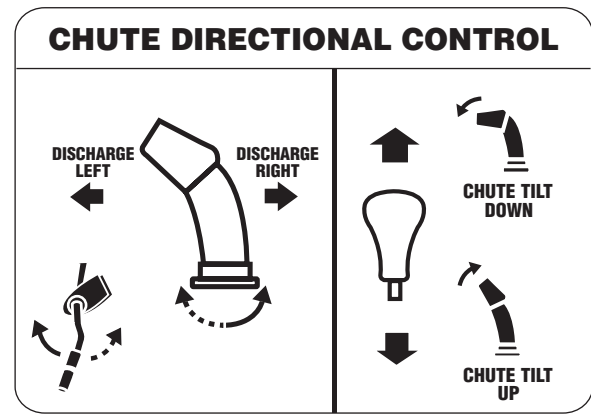

Chute Directional Control

The chute directional control is located on the left side of the snow thrower.

- To change the direction in which snow is thrown, crank clockwise to discharge to the left and counterclockwise to discharge to the right.

Wheel Steering Controls

The left and right wheel steering controls are located on the underside of the handles. Squeeze the right control to turn right; squeeze the left control to turn left.

NOTE: Operate the snow thrower in open areas until you are familiar with these controls.

Chute Clean-Out Tool



WARNING! Never use your hands to clear a clogged chute assembly. Shut off engine and remain behind handles until all moving parts have stopped before unclogging.

The chute clean-out tool is conveniently fastened to the rear of the auger housing with a mounting clip. Should snow and ice become lodged in the chute assembly during operation, proceed as follows to safely clean the chute assembly and chute opening:

1. Release both the Auger Control and the Drive Control.
2. Stop the engine as instructed in the engine operator's manual included with the snow thrower.
3. Remove the clean-out tool from the clip which secures it to the rear of the auger housing.
4. Use the shovel-shaped end of the clean-out tool to dislodge and scoop any snow and ice which has formed in and near the chute assembly.
5. Refasten the clean-out tool to the mounting clip on the rear of the auger housing, and start the engine as instructed in the engine operator's manual.
6. While standing in the operator's position (behind the snow thrower), engage the auger control for a few seconds to clear any remaining snow and ice from the chute assembly.

Starting and Stopping the Engine

Refer to the Engine Operator's Manual packed with your snow thrower for instructions on starting and stopping the engine.

To Engage Drive

1. With the throttle control in the Fast (rabbit) position, move shift lever into one of the six forward (F) positions or two reverse (R) positions. Select a speed appropriate for the snow conditions and a pace you're comfortable with.

NOTE: Use slower speeds in higher snow and/or until you are familiar with the snow thrower operation.

2. Squeeze the drive control against the handle the snow thrower will move. Release it and drive motion will stop.



CAUTION: NEVER move the shift lever without first releasing the wheel drive control. Doing so will cause premature wear on the drive system's friction wheel

3. To turn the snow thrower to the left or right, squeeze the respective wheel steering control. Refer to Figure 4-1.

To Engage Augers

1. To engage augers and start throwing snow, squeeze the auger control against the left handle. Release to stop augers.
2. While the auger control is engaged, squeeze the drive control to engage the interlock mechanism and to drive the snow thrower. The interlock mechanism locks the auger control so you can turn the chute control without interrupting the snow throwing process.
3. Release the auger control; the interlock mechanism keeps the auger control engaged until the drive control is released.
4. Release the drive control to stop both the augers and the wheel drive. To stop auger, both levers must be released.

Operating Tips

NOTE: Allow the engine to warm up for a few minutes. The engine will not develop full power until it reaches operating temperature.



WARNING: The temperature of the muffler and the surrounding areas may exceed 150° F. Avoid these areas.

1. If possible, remove snow immediately after it falls.
2. Discharge snow downwind whenever possible.
3. Slightly overlap each previous path.
4. Set the skid shoes 1/4" below the shave plate for normal usage. Adjust them upward for hard-packed snow and downward when using on gravel or crushed rock.

Replacing Shear Pins

Each of the auger spiral assemblies are secured to the spiral shaft with a shear pin and bow-tie cotter pin. If the auger should strike a foreign object or ice jam, the snow thrower is designed so that the pins may shear. If the augers will not turn, check to see if the pins have sheared. See Fig. 5-1.



CAUTION: NEVER replace the auger shear pins with anything other than OEM Part No. 738-04155 replacement shear pins. Any damage to the auger gearbox or other components as a result of failing to do so will NOT be covered by your snow thrower's warranty.

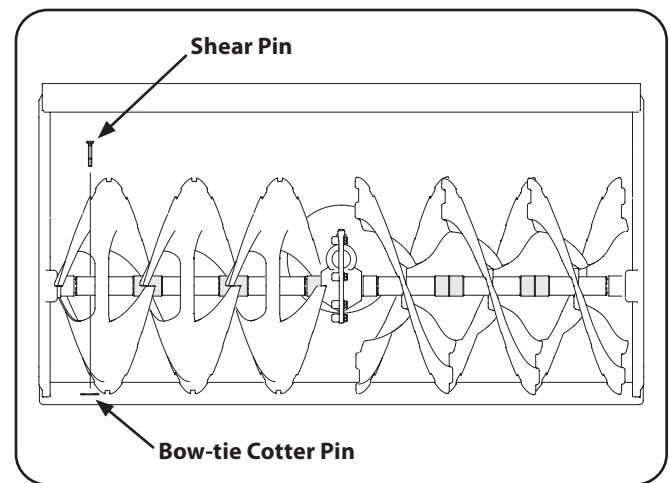

Figure 5-1



WARNING! Before performing any type of maintenance/service, disengage all controls and stop the engine. Wait until all moving parts have come to a complete stop. Remove the key to prevent unintended starting. Always wear safety glasses during operation or while performing any adjustments or repairs.

Engine

Refer to the Engine Operators Manual Maintenance section included with the snow thrower.

Lubrication

Drive and Shifting Mechanism

At least once a season or after every 25 hours of operation, remove rear cover. Lubricate all chains, sprockets, gears, bearings, shafts, and the shifting mechanism. Use engine oil or a spray lubricant. Refer to Figure 6-1.

NOTE: Before tipping the unit on the front housing, run the fuel tank empty so fuel does not leak out of the fuel cap.

1. Carefully pivot the snow thrower up and forward so that it rests on the auger housing.
2. Remove the frame cover from the underside of the snow thrower by removing the self-tapping screws which secure it. Refer to Figure 6-5.
3. Apply a light coating of engine oil (or 3-in-1 oil) to the hex shaft. See Fig. 6-1.

NOTE: When lubricating the hex shaft, be careful not to get any oil on the aluminum drive plate or the rubber friction wheel. Doing so will hinder the snow thrower's drive system. Wipe off any excess or spilled oil.

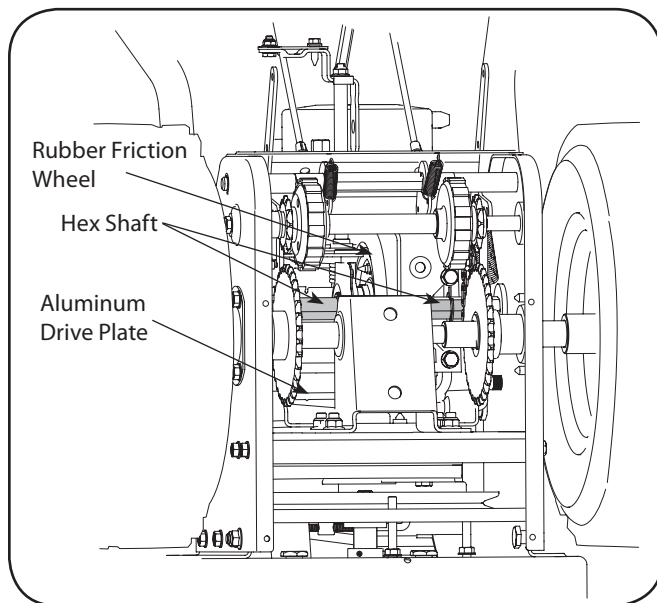

Figure 6-1

Wheels

At least once a season, remove both wheels. Clean and coat the axles with a multipurpose automotive grease before reinstalling wheels.

Chute Directional Control

Once a season, lubricate the eye bolt bushing and the spiral with 3-in-1 oil.

Auger Shaft

At least once a season, one at a time, remove all of the shear pins from the auger shaft. Spray lubricant inside the hub of each auger spiral assembly and around the spacers on the auger shaft.

Grease fittings can also be found at each end of the auger shaft. Lubricate with a grease gun once a season. See Figure 6-2.

Gear Case

The auger gear case is equipped with a grease fitting. Lubricate with grease once a season (order part number 737-0168). See Figure 6-2.

NOTE: To relieve pressure, remove the vent plug before lubricating the gear case. See Figure 6-2. Failure to do so could result in damage to the gear case seals.

Augers

Each of the auger spiral assemblies is secured to the spiral shaft with a shear pin and cotter pin. If the auger should strike a foreign object or ice jam, the snow thrower is designed so that the pins may shear.

1. If augers do not turn, check to see if pins have sheared.
2. Replace the pins if needed. Two replacement shear pins and cotter pins have been provided with the snow thrower. Spray an oil lubricant into shaft before inserting new pins and securing with new cotter pins. See Fig. 6-2.

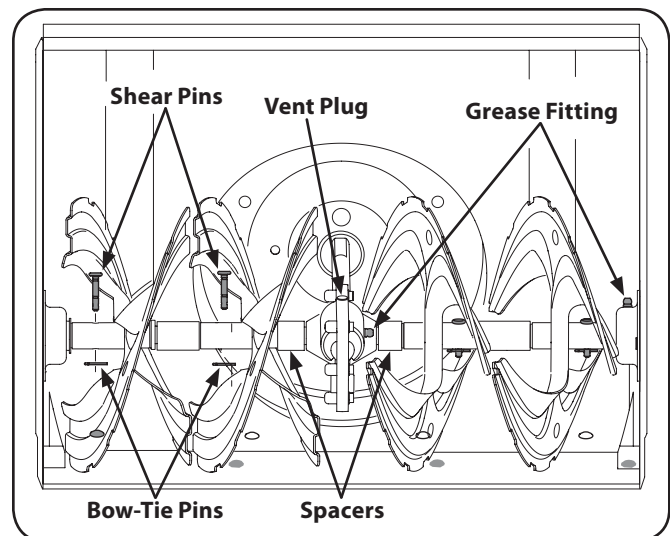

Figure 6-2

Shave Plate and Skid Shoes

The shave plate and skid shoes on the bottom of the snow thrower are subject to wear. They should be checked periodically and replaced when necessary.

Skid Shoes

NOTE: The skid shoes on this machine have two wear edges. When one side wears out, they can be rotated 180° to use the other edge. Refer to the Assembly section for instructions on adjusting the skid shoes.

1. Remove the six carriage bolts, flat washers and hex nuts that secure the two skid shoes to the sides of the auger housing. Refer to Fig. 6-3.
2. Position the new skid shoes and secure with the carriage bolts, flat washers and hex nuts. Make certain the skid shoes are adjusted to be level.

Shave Plate

1. Remove the hex nuts and carriage bolts that secure the shave plate to the bottom of the housing. See Fig. 6-3.
2. Remove the rear most hex nut and carriage bolt securing the back of each skid shoe to the sides of the housing. Loosen the remaining hex nuts securing the skid shoes.
3. Slide the shave plate out of the off-set slot at the bottom of the housing, and from between the skid shoes and side panels of the housing.
4. With the mounting holes toward the back of the unit, slide the new shave plate into position and secure with the fasteners previously removed and loosened.

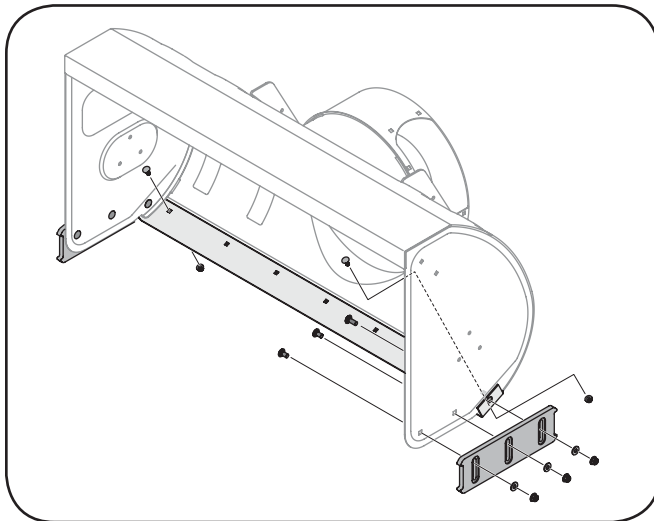

Figure 6-3

Adjustments

Shift Cable

If the full range of speeds (forward and reverse) cannot be achieved, refer to the Figure 6-4 and adjust the shift cable as follows:

1. Place the shift lever in the fastest forward speed position.
2. Loosen the hex nut on the shift cable index bracket. See Fig. 6-4.

3. Pivot the bracket downward to take up slack in the cable.
4. Retighten the hex nut.

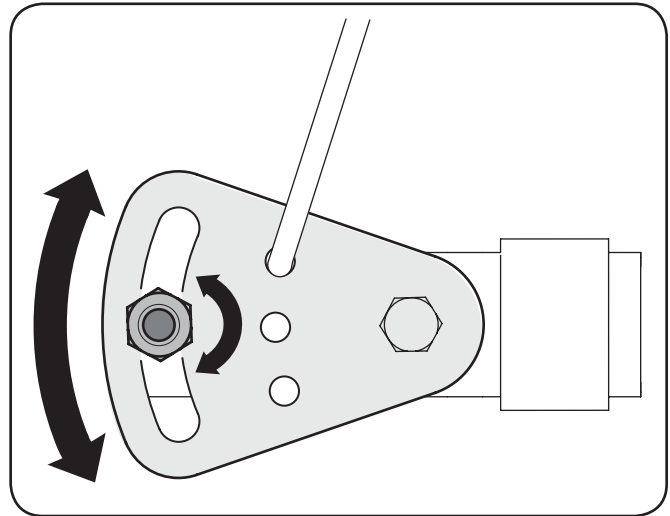

Figure 6-3

Chute Bracket Adjustment

If the spiral at the bottom of the chute directional control is not fully engaging with the chute assembly, the chute bracket can be adjusted. To do so:

1. Loosen the two nuts which secure the chute bracket and reposition it slightly. See Figure 6-5.
2. Retighten the nuts.

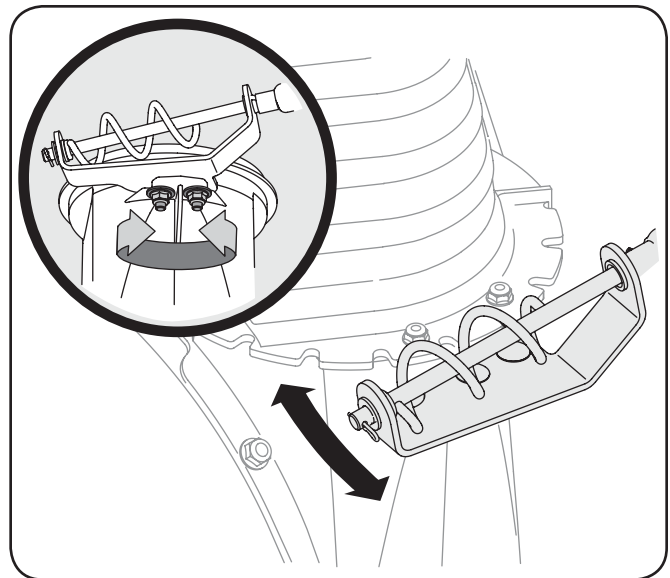

Figure 6-5

Chute Control

The distance snow is thrown can be adjusted by adjusting the angle of the chute assembly. Refer to the Operation section for instructions.

The remote chute control cables have been pre-adjusted at the factory. Move the remote chute lever on the control panel forward to pivot the upper chute down; move the lever rearward to pivot the upper chute up.

Wheel drive control

Refer to the Adjustment section of the Assembly & Set-Up section earlier in this manual for instructions on how to adjust the wheel drive control. To further check the adjustment, proceed as follows:

1. With the snow thrower tipped forward (be certain to run the fuel tank dry before tipping the unit forward), remove the frame cover underneath the snow thrower by removing the self-tapping screws. See Fig. 6-6.

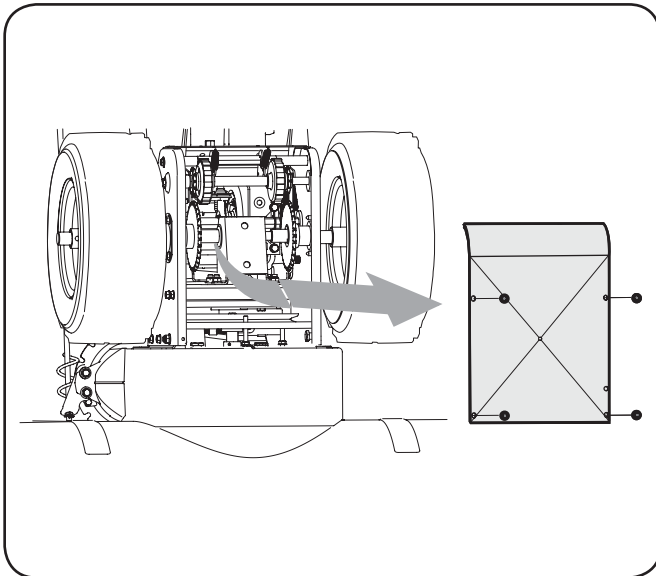

Figure 6-6

2. Locate the opening between the axle support bracket and the front frame support (See Figure 6-7). Looking through this opening, with the wheel drive control released, there must be clearance between the friction wheel and the drive plate in all positions of the speed selector lever.
3. With the wheel drive control engaged, the friction wheel must contact the drive plate. See Figure 6-7.

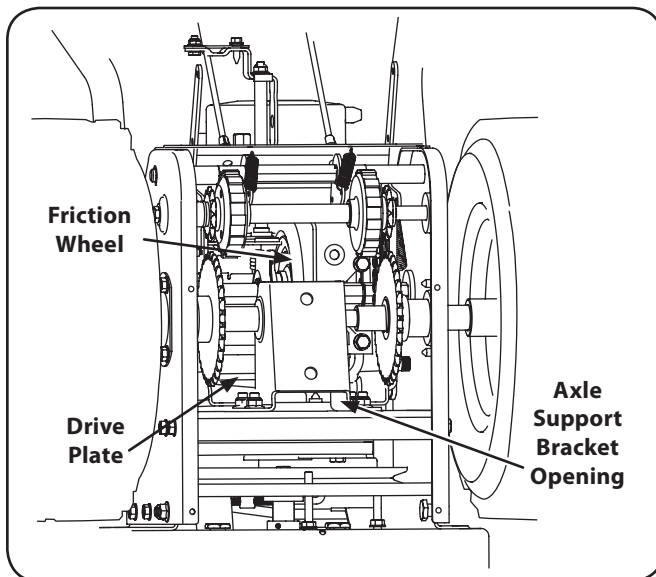

Figure 6-7

4. If there is no friction wheel clearance, or the friction wheel does not solidly contact the drive plate, re-adjust the lock nut on the lower end of the drive cable following the instructions in the Assembly section.
5. Reassemble the frame cover.

Auger Control

Refer to the Assembly section for instructions on adjusting the auger control cable.

Tire Pressure

Refer to the Assembly section for instructions on adjusting the tire pressure.

Off-Season Storage

If the snow thrower will not be used for 30 days or longer, follow the storage instructions below.

1. Lubricate the machine as instructed earlier in this section.
2. Store in a clean, dry area.
3. If storing the snow thrower in an unventilated area, rustproof the machine using a light oil or silicone to coat the snow thrower.
4. Clean the exterior of the engine and the snow thrower.

IMPORTANT: See the Engine Operator's Manual included with the snow thrower for complete engine off-season storage procedures.

Belt Replacement

Belt Removal Preparation

1. Remove the chute crank rod from the chute crank assembly by removing the hair pin clip shown in Fig. 7-1. Move the chute crank rod away from the assembly as shown.
2. Remove three self-tap screws on both sides of the transmission housing as shown in Fig. 7-1.

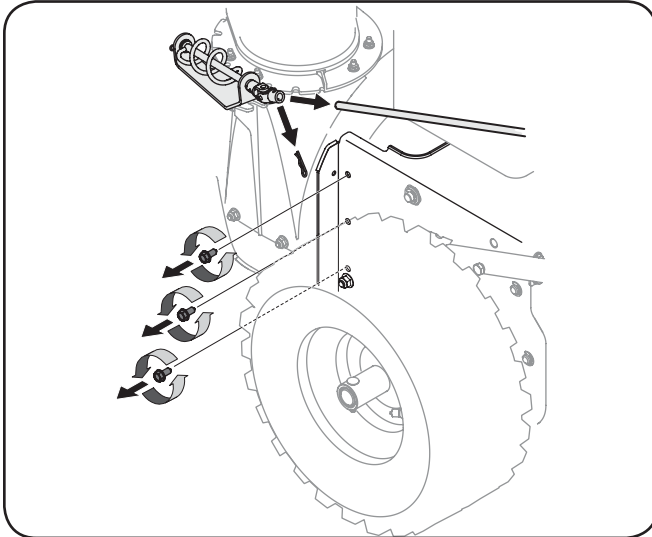

Figure 7-1

3. Remove the plastic belt cover on the front of the engine by removing the three self-tapping screws. See Fig. 7-2.

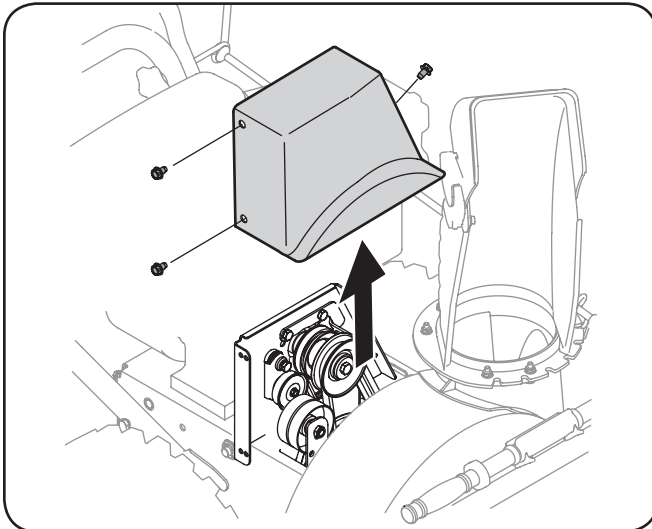

Figure 7-2

4. Loosen the bolt shown in Fig. 7-3 securing the belt keeper bracket and remove the other bolt. Push the belt keeper bracket up off the engine pulley. See Fig. 7-3.

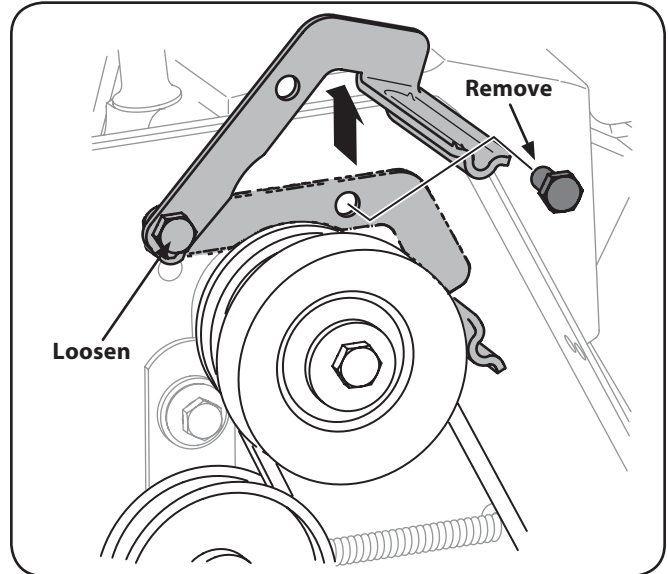

Figure 7-3

Auger Belt Replacement

To remove and replace your snow thrower's auger belt, proceed as follows:

1. Remove the bow tie clip and flat washer from the ferrule in order to disconnect the auger idler rod from the brake bracket assembly. See Fig. 7-4.

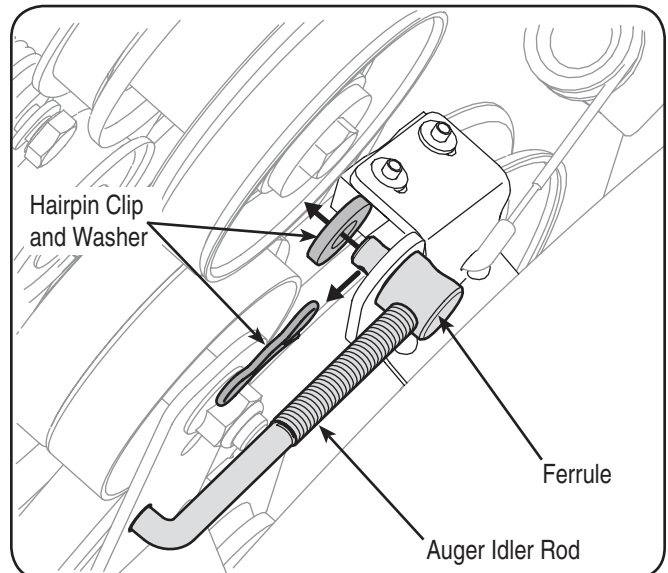

Figure 7-4

NOTE: Make sure to maintain the location of the ferrule on the idler rod.

2. Slip the auger control belt (the front belt) off the engine pulley.

3. Pull the brake bracket assembly towards the cable guide roller and unhook the auger cable "Z" fitting. Refer to Fig. 7-5.

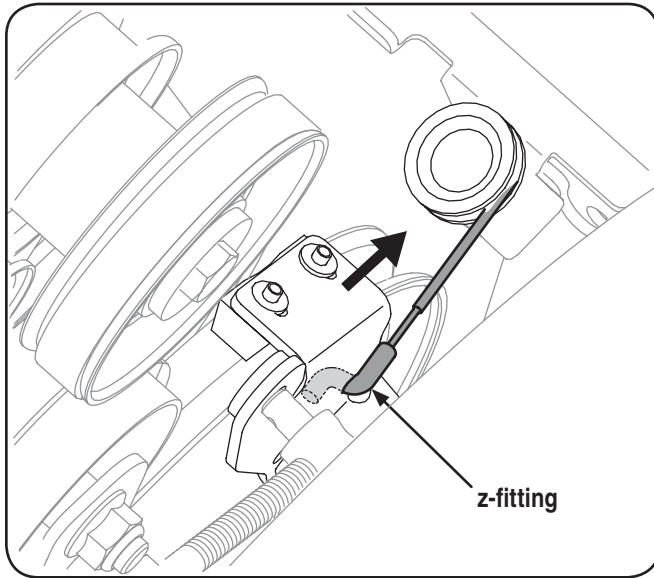

Figure 7-5

4. From both sides of the frame assembly, use a 1/2" wrench to remove the three hex tap screws securing the transmission frame to the auger housing assembly. Refer to Fig. 7-1. Do not remove the lower hex flange lock nut on each side.
5. Place a block of wood underneath the auger housing as shown in Fig. 7-6 and separate auger housing from the transmission frame by tilting the housing forward and pulling up the handles.

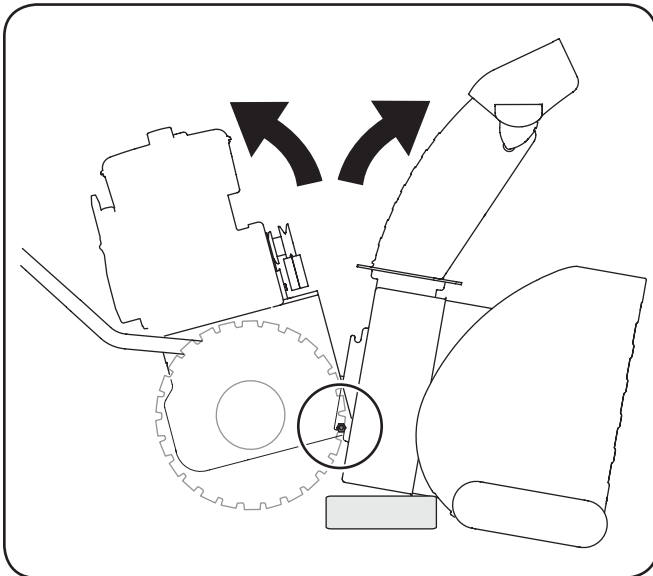

Figure 7-6

6. Block the impeller with a piece of wood to prevent from spinning and use a 1/2" wrench to remove the hex screw and flat washer from the center of the auger input shaft and auger pulley adapter. Refer to Fig. 7-7.

7. Lift the brake bracket assembly out of the pulley groove and slide the pulley assembly off the posts of the auger pulley adapter to remove the old belt. Refer to Fig. 7-7.

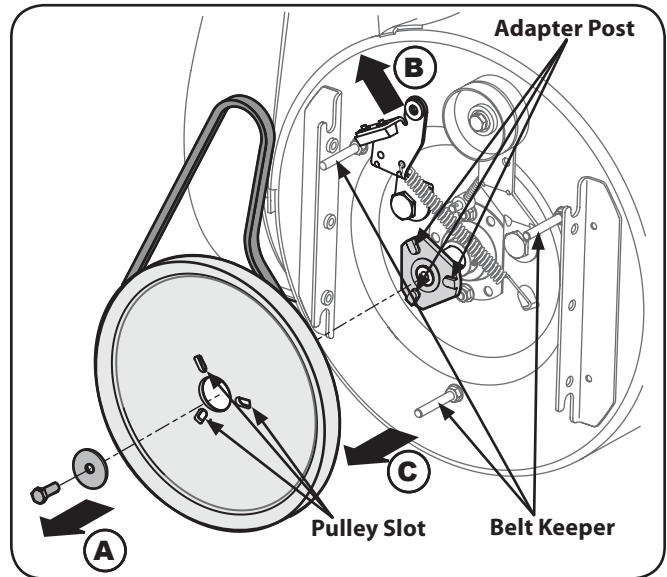

Figure 7-7

NOTE: The pulley adapter may slide off the auger input shaft when removing the pulley. Use extra caution to ensure the adapter does not fall and get damaged when removing the pulley.

8. Place the new auger belt in the V-groove of the auger pulley and place the pulley w/belt inside the belt keepers.
9. Turn the pulley as necessary to align its three slots with the posts of the pulley adapter, then move the brake bracket assembly away from the input shaft. While aligning the pulley slots and adapter posts, push the auger pulley fully onto the adapter. Refer to Fig. 7-7.

NOTE: If the pulley adapter was removed with the pulley, align the splines of the pulley adapter and auger input shaft, and push the pulley and adapter onto the input shaft. Refer to Fig. 7-7.

10. Slide the washer onto the hex screw removed earlier and apply Loctite 262 to the threads of the hex screw.
11. Insert the hex screw through the pulley assembly and into the threads of the input shaft. Torque the hex screw to 250-325 in. /lbs. to secure the auger pulley assembly on the input shaft.
12. If also replacing the drive belt, proceed to the "Drive Belt" instruction. If not, reposition the transmission frame back onto the auger housing. Install the drive belt on the engine pulley, re-connect the auger cable "Z" fitting and auger idler rod ferrule to the brake bracket. Reposition and secure the engine pulley belt guard, and re-install the belt cover.

NOTE: Make sure to remove the piece of wood blocking the impeller.

Check the auger drive belt adjustment. With the auger clutch lever in the disengaged position, the top surface of the new belt should be even with the outside diameter of the pulley.

To adjust, disconnect ferrule from brake bracket assembly. Thread ferrule in (towards idler) to increase tension on belt, or out to decrease belt tension.

NOTE: The brake puck must always be firmly seated in the pulley groove when auger control is disengaged.



CAUTION: Repeat the "Testing Auger Drive Control" from the Assembly & Set-up section before operating the snow thrower.

Drive Belt Replacement

If not already done, remove the auger drive belt from the front pulley of the engine double pulley. Refer to "Auger Belt Replacement" instructions in the previous sub-section.

1. Use a wrench to rotate the idler pulley away from the backside of the drive belt to relieve the tension and slip the drive belt off the idler pulley. Carefully release the idler pulley. See Fig. 7-8.

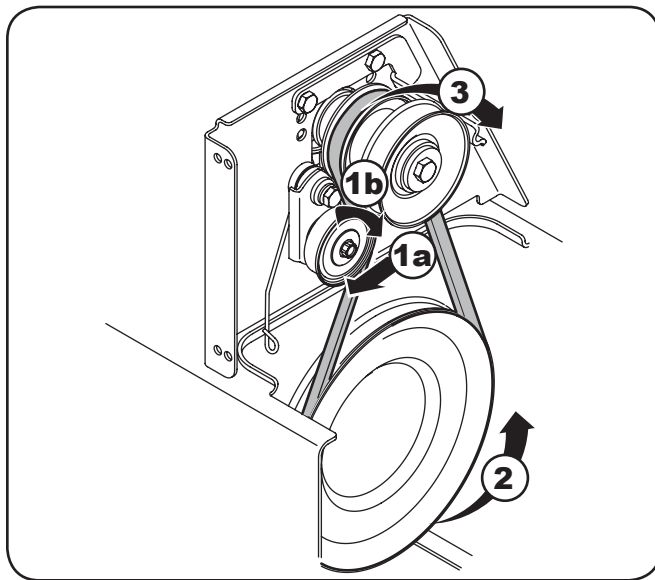

Figure 7-8

2. Roll the drive belt off the lower drive pulley and then remove the belt from the engine pulley.
3. Install the new belt on the engine pulley, then seat around the lower drive pulley and re-tension with the idler pulley.
4. Reassemble by performing the previous steps in the opposite order and manner of removal.

Changing Friction Wheel

The rubber on the friction wheel is subject to wear and should be checked after the first 25 hours of operation, and periodically thereafter. Replace the friction wheel if any signs of wear or cracking are found.

1. Drain the gasoline from the snow thrower, or place a piece of plastic under the gas cap.
2. Tip the snow thrower up and forward, so that it rests on the housing.
3. Remove screws from the frame cover underneath the snow thrower (refer to Fig. 7-9). Remove the right wheels from the axle.

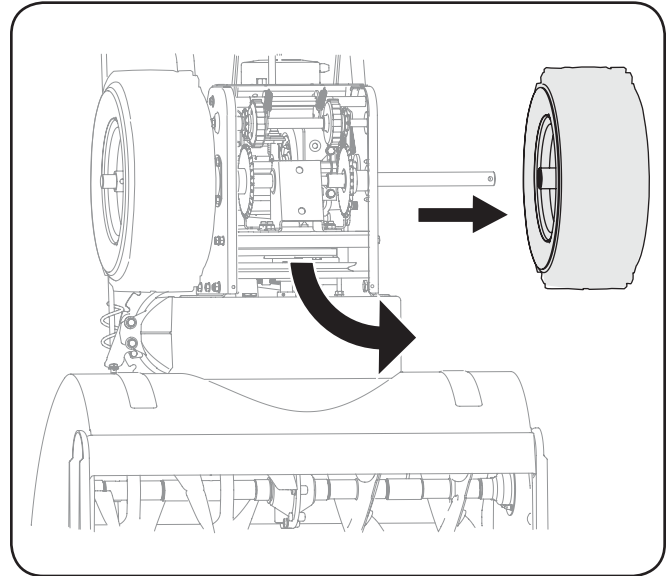

Figure 7-9

4. Using a 3/4" wrench, hold the hex shaft and remove the hex screw and belleville washer and bearing from left side of the frame. Refer to Fig. 7-10.

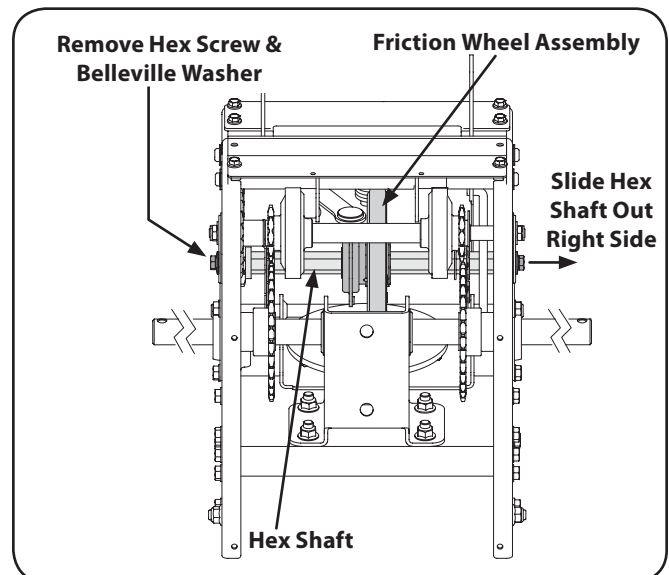

Figure 7-10

5. Holding the friction wheel assembly, slide the hex shaft out of the right side of the frame. The spacer on the left side of the hex shaft will fall and the sprocket should remain hanging loose in the chain.

6. Lift the friction wheel assembly out between the axle shaft and the drive shaft assemblies.
7. Remove four screws securing the friction wheel to the hub assembly (refer to Fig. 7-11). Discard old friction wheel.

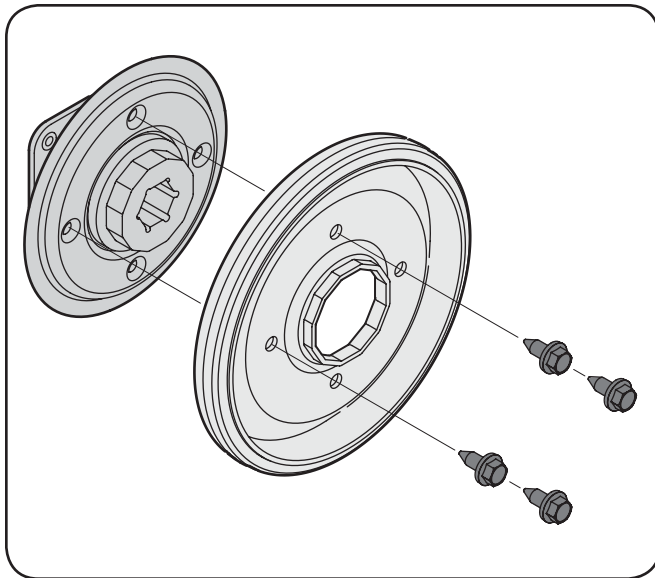

Figure 7-11

8. Reassemble the new friction wheel onto the hub assembly, tightening the four screws in rotation to 6-9 ft.-lbs. It is important to assemble the friction wheel symmetrically for proper functioning. Refer to Fig. 7-11.
9. Reposition the friction wheel assembly in the snow thrower frame. Insert the pin from the shift arm assembly into the friction wheel assembly and hold assembly in position. Refer to Fig. 7-12.

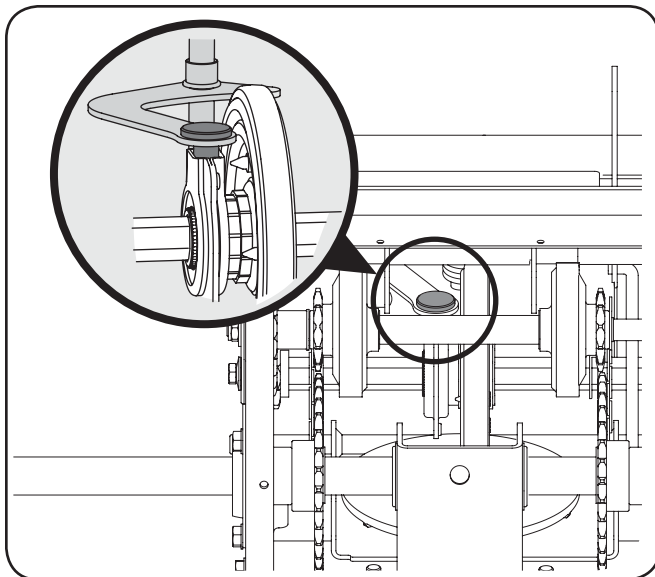

Figure 7-12





10. Slide the hex shaft through the right side of the frame toward the left side and through the friction wheel assembly.

NOTE: If the sprocket fell from the snow thrower chain while removing the hex shaft, position the hex hub of the sprocket toward the friction wheel and place the sprocket in the chain.

11. After making certain that the chain is on both the large and the small sprocket, align the hex shaft with the hex hub of the small sprocket, and slide the shaft through the sprocket.
12. Slide the spacer onto the end of the hex shaft.
13. Align the bearing on the right end of the hex shaft with the hole in the right side of the frame, then push the hex shaft to the left into position in the frame.
14. Slide the bearing onto the left end of the hex shaft and press into the hole on the left side the frame.
15. Place the belleville washer (rounded side toward head) onto the hex screw removed earlier, and insert the screw into the threaded hole of the hex shaft.
16. Gradually tighten the hex screw to fully seat the bearings in each side of the frame and to secure the hex shaft.
17. Position the frame cover on the bottom of the frame and secure with the self-tapping screws. Pivot the snow thrower down to its normal operating position.

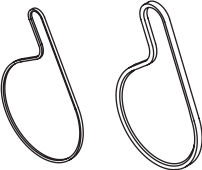
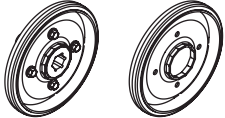
IMPORTANT: Repeat the drive control test from the Assembly & Set-Up section of this manual before operating the snow thrower.

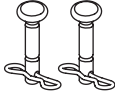
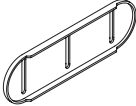
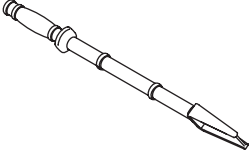
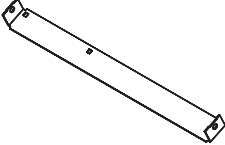
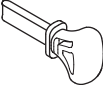
Problem	Cause	Remedy
Excessive vibration	1. Loose parts or damaged auger.	1. Stop engine immediately and disconnect spark plug wire. Tighten all bolts and nuts. If vibration continues, have unit serviced by an authorized Service Center.
Loss of power	1. Spark plug wire loose. 2. Gas cap vent hole plugged.	1. Connect and tighten spark plug wire. 2. Remove ice and snow from gas cap. Be certain vent hole is clear.
Unit fails to propel itself	1. Drive control cable in need of adjustment. 2. Drive belt loose or damaged. 3. Friction wheel worn.	1. Adjust drive control cable. Refer to Maintenance section 2. Replace drive belt. 3. Replace Friction Wheel.
Unit fails to discharge snow	1. Chute assembly clogged. 2. Foreign object lodged in auger. 3. Auger control cable in need of adjustment. 4. Auger belt loose or damaged. 5. Shear pin(s) sheared.	1. Stop engine immediately and disconnect spark plug wire. Clean chute assembly and inside of auger housing with clean-out tool or a stick. 2. Stop engine immediately and disconnect spark plug wire. Remove object from auger with clean-out tool or a stick. 3. Refer to Auger Control Test. 4. Refer to Maintenance section. 5. Replace with new shear pin(s).
Chute Fails to Rotate	6. Improper adjustment of Chute Bracket.	7. Refer to Maintenance Section for Chute Bracket Adjustment.

Component	Part Number and Description
	929-0071A Extension Cord, 110V
	954-04154A Auger Drive Belt 954-04202 Wheel Drive Belt
	918-04178 Friction Wheel Assembly 718-04034 Friction Wheel w/Bonded Rubber
	725-1629 Lamp
	738-04155 Shear Pin 714-04040 Bow-tie Cotter Pin
	784-5697 Slide Shoe, Deluxe
	931-2643 Chute Clean-out Tool
	790-00280 Shave Plate
	731-05632 Key
	951-10292 Spark Plug

Phone (800) 828-5500 to order replacement parts or a complete Parts Manual (have your full model number and serial number ready). Parts Manual downloads are also available free of charge at www.troybilt.com.

The following attachments and accessories are available for your Cub Cadet 900 series snow thrower. See your Cub Cadet dealer or the retailer from which you purchased your snow thrower for information regarding price and availability.

Model Number	Description
490-241-0013	Auger and Chute anti-stick spray
OEM-390-674	Heavy Duty Snow Cab
OE731-2643	Clearing Tool
OEM-390-679	Drift Cutter Kit
OEM-390-995	Snow Thrower Protective Cover

Blank lined writing area.

**MTD CONSUMER GROUP INC (MTD), the California Air Resources Board (CARB)
and the United States Environment Protection Agency (U. S. EPA)**

**Emission Control System Warranty Statement
(Owner's Defect Warranty Rights and Obligations)**

EMISSION CONTROL SYSTEM COVERAGE IS APPLICABLE TO CERTIFIED ENGINES PURCHASED IN CALIFORNIA IN 2005 AND THEREAFTER, WHICH ARE USED IN CALIFORNIA, AND TO CERTIFIED MODEL YEAR 2005 AND LATER ENGINES WHICH ARE PURCHASED AND USED ELSEWHERE IN THE UNITED STATES.

California and elsewhere in the United States Emission Control Defects Warranty Coverage

The California Air Resources Board (CARB), U. S. EPA and MTD are pleased to explain the emissions control system warranty on your model year 2006 and later small off-road engine. In California, new small off-road engines must be designed, built and equipped to meet the States anti-smog standards. Elsewhere in the United States, new non-road, spark-ignition engines certified for model 2005 and later, must meet similar standards set forth by the U. S. EPA. MTD warrants the emission control system on your engine for the period of time listed below, provided there has been no abuse, neglect or improper maintenance of your small off-road engine.

Your emission control system may include parts such as the carburetor, fuel-injection system, the ignition system, and catalytic converter, fuel tanks, fuel lines, fuel caps, valves, canisters, filters, vapor hoses, clamps, connectors, and other associated emission-related components.

Where a warrantable condition exists, MTD will repair your small off-road engine at no cost to you including diagnosis, parts and labor.

MANUFACTURER'S WARRANTY COVERAGE:

This emissions control system is warranted for two years. If any emission-related part on your engine is defective, the part will be repaired or replaced by MTD.

OWNER'S WARRANTY RESPONSIBILITIES:

As the small off-road engine owner, you are responsible for the performance of the required maintenance listed in your Owner's Manual. MTD recommends that you retain all your receipts covering maintenances on your small off-road engine, but MTD can not deny warranty solely for the lack of receipts or for your failure to ensure the performance to all scheduled maintenance.

As the small off-road engine owner, you should however be aware that MTD may deny your warranty coverage if your small off-road engine or part has failed due to abuse, neglect, improper maintenance or unapproved modifications.

You are responsible for presenting your small off-road engine to an Authorized MTD Service Dealer as soon as a problem exists. The warranted repairs should be completed in a reasonable amount of time, not to exceed 30 days.

If you have any questions regarding your warranty rights and responsibilities, you should contact a MTD Service Representative at 1-800-800-7310 and address is MTD CONSUMER GROUP, P.O. Box 361131, Cleveland OH, 44136-0019.

DEFECTS WARRANTY REQUIREMENTS FOR 1995 AND LATER SMALL OFF-ROAD ENGINES:

This section applies to 1995 and later small off-road engines. The warranty period begins on the date the engine or equipment is delivered to an ultimate purchaser.

(a) General Emissions Warranty Coverage

MTD must warrant to the ultimate purchaser and each subsequent purchaser that the engine is:

- (1) Designed, built, and equipped so as to conform with all applicable regulations adopted by the Air Resources Board pursuant to its authority in Chapters 1 and 2, Part 5, Division 26 of the Health and Safety Code; and
- (2) Free from defects in materials and workmanship that cause the failure of a warranted part to be identical in all material respects to the part as described in the engine manufacturer's application for certification for a period of two years.

(b) The warranty on emissions-related parts will be interpreted as follows:

- (1) Any warranted part that is not scheduled for replacement as required maintenance in the written instructions required by Subsection (c) must be warranted for the warranty period defined in Subsection (a)(2). If any such part fails during the period of warranty coverage, it must be repaired or replaced by MTD according to Subsection (4) below. Any such part repaired or replaced under the warranty must be warranted for the remaining warranty period.
- (2) Any warranted part that is scheduled only for regular inspection in the written instructions required by Subsection (c) must be warranted for the warranty period defined in Subsection (a)(2). A statement in such written instructions to the effect of "repair or replace as necessary" will not reduce the period of warranty coverage. Any such part repaired or replaced under warranty must be warranted for the remaining warranty period.
- (3) Any warranted part that which is scheduled for replacement as required maintenance in the written instructions required by Subsection (c) must be warranted for the period of time prior to the first scheduled replacement point for that part. If the part fails prior to the first scheduled replacement, the part must be repaired or replaced by MTD according to Subsection (4) below. Any such part repaired or replaced under warranty must be warranted for the remainder of the period prior to the first scheduled replacement point for the part.

(4) Repair or replacement of any warranted part under the warranty provisions of this article must be performed at no charge to the owner at a warranty station.

(5) Notwithstanding the provisions of Subsection (4) above, warranty services or repairs must be provided at all MTD distribution centers that are franchised to service the subject engines.

(6) The owner must not be charged for diagnostic labor that leads to the determination that a warranted part is in fact defective, provided that such diagnostic work is performed at a warranty station.

(7) The engine manufacturer is liable for damages to other engine components proximately caused by a failure under warranty of any warranted part.

(8) Throughout the engine's warranty period defined in Subsection (a)(2), MTD will maintain a supply of warranted parts sufficient to meet the expected demand for such parts.

(9) Any replacement part may be used in the performance of any warranty maintenance or repairs and must be provided without charge to the owner. Such use will not reduce the warranty obligations of MTD.

(10) Add-on or modified parts that are not exempted by the Air Resources Board may not be used. The use of any non-exempted add-on or modified parts shall be grounds for disallowing a warranty claim made in accordance with this article. The engine manufacturer shall not be liable under this article to warrant failures of warranted parts caused by the use of non-exempted add-on or modified part.

(c) MTD will include a copy of the following emission warranty parts list with each new engine, using those portions of the list applicable to the engine.

(1) Fuel Metering System

- Cold start enrichment system (soft choke)
- Carburetor and internal parts
- Fuel Pump
- Fuel Tank

(2) Air Induction System

- Air cleaner
- Intake manifold

(3) Ignition System

- Spark plug(s)
- Magneto Ignition System

(4) Exhaust System

- Catalytic converter
- SAI (Reed valve)

(5) Miscellaneous Items Used in Above System

- Vacuum, temperature, position, time sensitive valves and switches
- Connectors and assemblies

(6) Evaporative control

- Fuel Hose certified for ARB evaporative emission of 2006.
- Fuel Hose Clamps
- Tethered fuel cap
- Carbon canister
- Vapor lines

CUB CADET LLC MANUFACTURER'S LIMITED WARRANTY FOR SNOW THROWERS

The limited warranty set forth below is given by Cub Cadet LLC with respect to new merchandise purchased and used in the United States, its possessions and territories, and by MTD Products Limited with respect to new merchandise purchased and used in Canada and/or its territories and possessions.

For non-commercial use: Cub Cadet warrants this product (excluding *Normal Wear Parts*, as described below) against defects in material and workmanship for a period of three (3) years from the date of original retail purchase or lease.

For commercial uses and applications: Cub Cadet warrants this product (excluding *Normal Wear Parts*, as described below) against defects in material and workmanship for a period of one (1) year from the date of original retail purchase or lease.

"Cub Cadet" will, at its option, repair or replace, free of charge, any part found to be defective in materials or workmanship. This limited warranty shall only apply if this product has been operated and maintained in accordance with the Operator's Manual furnished with the product, and has not been subject to misuse, abuse, neglect, accident, improper maintenance, alteration, vandalism, theft, fire, water, or damage because of other peril or natural disaster. Damage resulting from the installation or use of any part, accessory or attachment not approved by Cub Cadet for use with the product(s) covered by this manual will void your warranty as to any resulting damage.

Normal Wear Parts are warranted to be free from defects in material and workmanship for a period of thirty (30) days from the date of purchase. Normal wear parts include, but are not limited to items such as: belts, skid shoes, shave plates and tires.

HOW TO OBTAIN SERVICE: Warranty service is available, WITH PROOF OF PURCHASE, through your local authorized service dealer. To locate the dealer in your area:

In the U.S.A.

To locate the dealer in your area, check your Yellow Pages, or contact Cub Cadet LLC at P.O. Box 361131, Cleveland, Ohio 44136-0019, or call 1-877-282-8684, or log on to our Web site at www.cubcadet.com.

In Canada

Contact MTD Products Limited, Kitchener, ON N2G 4J1, or call 1-800-668-1238 or log on to our Web site at www.mtdcanada.com.

This limited warranty does not provide coverage in the following cases:

- a. Routine maintenance items such as lubricants, filters, blade sharpening, tune-ups, brake adjustments, clutch adjustments, deck adjustments, and normal deterioration of the exterior finish due to use or exposure.

- b. Cub Cadet does not extend any warranty for products sold or exported outside of the United States and/or Canada, and their respective possessions and territories, except those sold through Cub Cadet's authorized channels of export distribution.
- c. Replacement parts that are not genuine Cub Cadet parts.
- d. Service completed by someone other than an authorized service dealer.
- e. Transportation charges and service calls.

No implied warranty, including any implied warranty of merchantability of fitness for a particular purpose, applies after the applicable period of express written warranty above as to the parts as identified. No other express warranty, whether written or oral, except as mentioned above, given by any person or entity, including a dealer or retailer, with respect to any product, shall bind Cub Cadet. During the period of the warranty, the exclusive remedy is repair or replacement of the product as set forth above.

The provisions as set forth in this warranty provide the sole and exclusive remedy arising from the sale. Cub Cadet shall not be liable for incidental or consequential loss or damage including, without limitation, expenses incurred for substitute or replacement lawn care services or for rental expenses to temporarily replace a warranted product.

Some states do not allow the exclusion or limitation of incidental or consequential damages, or limitations on how long an implied warranty lasts, so the above exclusions or limitations may not apply to you.

In no event shall recovery of any kind be greater than the amount of the purchase price of the product sold. **Alteration of safety features of the product shall void this warranty.** You assume the risk and liability for loss, damage, or injury to you and your property and/or to others and their property arising out of the misuse or inability to use the product.

This limited warranty shall not extend to anyone other than the original purchaser or to the person for whom it was purchased as a gift.

HOW STATE LAW RELATES TO THIS WARRANTY: This limited warranty gives you specific legal rights, and you may also have other rights that vary in different jurisdictions.

IMPORTANT: Owner must present Original Proof of Purchase to obtain warranty coverage.

**Cub Cadet LLC, P.O. BOX 361131 CLEVELAND, OHIO 44136-0019; Phone: 1-877-282-8684
MTD Canada Limited - KITCHENER, ON N2G 4J1; Phone 1-800-668-1238**