



Liebert®

APM™

User Manual—15-90kVA, 120, 208, 480 and 600V, 50/60Hz

The information contained in this document is subject to change without notice and may not be suitable for all applications. While every precaution has been taken to ensure the accuracy and completeness of this document, Vertiv assumes no responsibility and disclaims all liability for damages resulting from use of this information or for any errors or omissions. Refer to other local practices or building codes as applicable for the correct methods, tools, and materials to be used in performing procedures not specifically described in this document.

The products covered by this instruction manual are manufactured and/or sold by Vertiv. This document is the property of Vertiv and contains confidential and proprietary information owned by Vertiv. Any copying, use or disclosure of it without the written permission of Vertiv is strictly prohibited.

Names of companies and products are trademarks or registered trademarks of the respective companies. Any questions regarding usage of trademark names should be directed to the original manufacturer.

Technical Support Site

If you encounter any installation or operational issues with your product, check the pertinent section of this manual to see if the issue can be resolved by following outlined procedures. Visit <https://www.VertivCo.com/en-us/support/> for additional assistance.

TABLE OF CONTENTS

IMPORTANT SAFETY INSTRUCTIONS	1
GLOSSARY OF SYMBOLS	5
1.0 INTRODUCTION	6
1.1 Battery Maintenance	6
1.1.1 Battery Safety Precautions	7
2.0 INSTALLATION	10
2.1 Initial Inspections	10
2.1.1 Storing for Delayed Installation	11
2.2 Preliminary Checks	11
2.2.1 Identification	11
2.3 UPS Location	11
2.3.1 Positioning the UPS	11
2.3.2 Environmental Considerations	11
2.4 Considerations in Moving the Liebert APM	12
2.5 Mechanical Considerations	12
2.5.1 Clearances	13
2.5.2 Floor Installation	13
2.5.3 Cable Entry	13
2.5.4 Special Considerations for Parallel Systems	14
2.5.5 Special Considerations for 1+N Parallel Systems	15
2.6 45kVA and 90kVA UPS Frames—Auxiliary Cabinets	15
2.6.1 Optional Cabinets	16
2.7 Optional Seismic Brackets	17
2.8 Liebert FlexPower™ Assembly	17
2.9 Static Bypass Assembly	18
3.0 ELECTRICAL CONNECTIONS—UPS	19
3.1 Power Cabling	19
3.1.1 Cable Rating	19
3.2 External Protective Devices	19
3.2.1 Rectifier and Bypass Input Supply of the UPS	20
3.2.2 External Battery	20
3.2.3 UPS Output	20
3.2.4 UPS Input Configuration	21
3.2.5 UPS Input Configuration with Transformers	22
3.2.6 Cabling Guidelines	24
3.2.7 Cable Connections	25
3.2.8 Accessory Fuses and Backfeed Breaker Wiring	31
3.2.9 Safety Ground	33
3.2.10 Protective Devices	35
3.2.11 Cabling Procedure	36
3.3 Control Cables Details	37
3.3.1 Static Bypass Assembly Features	37

3.4	Dry Contacts.....	39
3.4.1	Input Dry Contacts.....	39
3.4.2	Output Dry Contacts.....	41
3.4.3	Liebert BDC Interface.....	42
3.4.4	Battery Cabinet Interface Connectors.....	42
3.4.5	EPO Input—Optional.....	43
4.0	PARALLEL SYSTEM AND LBS SYSTEM INSTALLATION.....	45
4.1	General.....	45
4.2	System Installation Procedures.....	45
4.2.1	Preliminary Checks.....	45
4.2.2	Cabinet Installation.....	46
4.2.3	External Protective Device.....	47
4.2.4	Power Cable.....	47
4.2.5	Input Breaker Control Wiring.....	48
4.2.6	Output Breaker Control Wiring.....	48
4.2.7	Parallel Cables.....	50
4.2.8	Key Interlock System.....	51
4.2.9	Remote EPO.....	52
4.3	LBS System.....	53
4.3.1	Cabinet Installation.....	53
4.3.2	External Protective Device.....	54
4.3.3	Power Cable.....	54
4.3.4	Control Cable.....	54
5.0	BATTERY INSTALLATION.....	56
5.1	Introduction.....	56
5.2	Safety.....	56
5.3	UPS Batteries—Liebert APM 45kVA Frame Only.....	57
5.3.1	Internal Battery Breaker Component Locations and Control Wiring.....	57
5.4	External Battery Cabinet Installation.....	59
5.4.1	Matching Battery Cabinets.....	59
5.4.2	Connecting the Batteries.....	61
5.4.3	Installation Considerations.....	65
5.4.4	Connecting the Battery Cabinet to the UPS.....	65
5.5	Non-Standard Batteries.....	68
5.6	Battery Ground Fault Detection Option.....	69
6.0	LIEBERT BDC™.....	71
6.1	Normal (UPS) Mode.....	71
6.2	UPS Static Bypass Mode.....	72
6.3	Maintenance Mode.....	72
6.4	Locating the Cabinet.....	72
6.5	Cable Installation.....	72
6.5.1	Wiring Preparation.....	72
6.5.2	Power Cable Installation.....	73
6.5.3	Input/Output Wiring.....	73
6.6	Bolting Cabinets Together.....	76

7.0	INSTALLATION DRAWINGS	77
8.0	LIEBERT INTELLISLOT™ INSTALLATION	96
8.1	Liebert IntelliSlot Communication	96
8.2	Liebert IntelliSlot Web Card—SNMP/HTTP Network Interface Card	96
8.2.1	Liebert IntelliSlot™ Unity Cards—IS-UNITY-LIFE, IS-UNITY-S, IS-UNITY-DP	96
8.3	Liebert IntelliSlot Card Web Interface	96
8.4	Liebert IntelliSlot™ Relay Card	98
8.4.1	Liebert IntelliSlot Relay Card Pin Configuration	98
8.4.2	Liebert IntelliSlot™ Relay Card Jumper Setup	99
8.5	Alber® BDSi™ Battery Monitoring System—Optional	100
8.6	Battery Temperature Compensation	101
9.0	OPERATOR CONTROL AND DISPLAY PANEL	102
9.1	Operator Control Panel	102
9.2	Mimic Display Indicators	103
9.3	Control Buttons	104
9.4	Alarm Buzzer	104
9.5	LCD Overview	105
9.6	Navigation Keys	106
9.7	LCD Menus and Data Items	107
9.8	Language Selection	109
9.9	Current Date and Time	109
9.10	UPS History Log	110
9.11	Types of LCD Screens	111
9.11.1	Opening Display	111
9.11.2	Default Screen	111
9.11.3	UPS Help Screen	112
9.11.4	Screen Saver Window	112
9.12	Pop-Up Windows	113
9.12.1	From Bypass to Inverter Mode With Power Interruption	113
9.12.2	From Inverter to Bypass Mode With Interruption	113
9.12.3	System Self-Test	114
9.12.4	Battery Capacity Test Confirmation	114
9.12.5	Battery Self-Test Aborted, Condition Not Met	114
9.12.6	Battery Equalize Charge	114
9.12.7	Battery Reset	114
9.12.8	Battery Refresh Charge Aborted, Condition Not Met	114
9.12.9	Enter Control Password	114
10.0	OPERATION	118
10.1	Liebert APM Operating Modes	118
10.2	UPS Startup	120
10.2.1	Startup Procedure	120
10.2.2	Startup in ECO Mode	122
10.2.3	Switching Between UPS Operation Modes	122
10.3	UPS Battery Start	123

10.4	Switching the UPS from Normal Operation to Maintenance Bypass.....	124
10.5	Switching the UPS from Maintenance Bypass to Normal Operation.....	125
10.6	De-Energize Liebert APM with Maintenance Bypass Cabinet.....	126
10.7	De-Energize Liebert APM Without Maintenance Bypass Cabinet.....	126
10.8	Operation of Two Liebert APM Units in Parallel Setup.....	128
10.8.1	Procedure to Take UPS1 Offline While Leaving UPS2 Online.....	128
10.8.2	Procedure to Put UPS1 Back Online.....	129
10.8.3	Procedure to Take UPS2 Offline While Leaving UPS1 Online.....	129
10.8.4	Procedure to Put UPS2 Back Online.....	129
10.9	APM Procedure from Parallel Inverter Operation to Wrap-Around Bypass.....	129
10.10	APM Procedure from Wrap-Around Bypass to Parallel Inverter Operation.....	130
10.11	Parallel APM System Startup.....	130
10.12	Parallel APM System Shutdown.....	130
10.13	Emergency Shutdown With EPO.....	130
10.14	Auto Restart.....	131
10.15	Reset After Shutdown for Emergency Stop (EPO Action) or Other Conditions.....	131
10.16	Battery Protection.....	131
10.16.1	Battery Undervoltage Warning.....	131
10.16.2	Battery End-of-Discharge (EOD) Protection.....	131
10.17	Replacing Dust Filters.....	132
10.18	Operation.....	133
10.19	Static Bypass Switch.....	136
11.0	SPECIFICATIONS AND TECHNICAL DATA.....	137
11.1	Conformity and Standards.....	137
11.2	UPS Environmental.....	137
11.3	Batteries Approved for Use in Liebert APM Systems.....	139
11.4	UPS Electrical Characteristics.....	140
12.0	MAINTENANCE.....	146
12.1	Safety Precautions.....	146
12.2	Limited Life Components.....	147
12.3	Routine Maintenance.....	147
12.3.1	Record Log.....	147
12.3.2	Air Filters.....	148
12.3.3	Battery Maintenance.....	148
12.3.4	Battery Safety Precautions.....	148
12.3.5	Torque Requirements.....	151
12.4	Detecting Trouble.....	151
12.5	Reporting a Problem.....	151
12.6	Corrective Actions.....	152
12.7	Recommended Test Equipment.....	152
APPENDIX A - HAZARDOUS SUBSTANCES OR ELEMENTS ANNOUNCEMENT		
A153		
APPENDIX B - UPS STATUS MESSAGES.....		A154

FIGURES

Figure 1	Cabinet arrangement.....	13
Figure 2	Liebert FlexPower assembly indicators and controls	14
Figure 3	Static bypass assembly connections.....	15
Figure 4	Single UPS block diagram—dual input single source configuration.....	18
Figure 5	Liebert APM in a split bypass configuration.....	19
Figure 6	Control wiring for the dual input transformer configuration	20
Figure 7	Input busbars—Liebert APM 45kVA frame	22
Figure 8	Input busbars—Liebert APM 90kVA frame	23
Figure 9	Liebert BDC	24
Figure 10	Busbars—Liebert BDC	25
Figure 11	Busbars—External 600mm battery cabinet.....	26
Figure 12	Busbars—External 900mm battery cabinet.....	27
Figure 13	Accessory fuses.....	28
Figure 14	Dual input backfeed breaker wiring when bypass distribution cabinet not used....	29
Figure 15	Ground and neutral busbar connections—45kVA frame busbars.....	31
Figure 16	Ground and neutral busbar connections—90kVA frame busbars.....	32
Figure 17	Static bypass assembly connections to display cabinet and options	35
Figure 18	Auxiliary terminal block detail (static switch assembly front panel)	35
Figure 19	Input dry contacts.....	36
Figure 20	Output dry contacts and EPO wiring	37
Figure 21	EPO wiring and signal names for J6.....	39
Figure 22	Single UPS Remote Emergency Power Off	40
Figure 23	UPS system with external maintenance switch	42
Figure 24	Input breaker control wiring for parallel systems.....	43
Figure 25	Output breaker control wiring.....	44
Figure 26	Connection of parallel control cables of parallel system	45
Figure 27	Key interlock system control wiring	46
Figure 28	Locations of ports J1, J2 and J3 on bypass module	47
Figure 29	Remote Emergency Power Off wiring for parallel UPS	47
Figure 30	Typical dual bus system (with STS and LBS).....	48
Figure 31	Connection of typical dual bus system of two parallel systems	49
Figure 32	Connection of typical dual bus system of two single UPS's without redundant LBS cable	49
Figure 33	Connection of typical dual bus system of two single UPS's with redundant LBS cable	50
Figure 34	Internal battery breaker component locations	52
Figure 35	Internal battery control wiring.....	53
Figure 36	Bolting the battery cabinet to the Liebert APM	54
Figure 37	Battery cabinet, 600mm wide—details	55
Figure 38	Battery trays for 600mm battery cabinet	56
Figure 39	Battery cabinet with trays for 900mm battery cabinet.....	57
Figure 40	Battery cabinet connection to Liebert APM.....	59
Figure 41	Battery ground fault detection component location	61
Figure 42	Control wiring diagram for battery ground fault detection option	62

Figure 43 Single input UPS with external Liebert BDC with optional internal transformer—typical configuration	63
Figure 44 Liebert BDC—access plate removed	64
Figure 45 BDC connection to Liebert APM	66
Figure 46 Bolting Liebert APM to a Liebert BDC	67
Figure 47 UPS dimensions- front view	68
Figure 48 Lineup arrangement, Liebert APM with battery and Liebert BDCs	69
Figure 49 UPS dimensions continued, center of gravity—side, top and bottom views	70
Figure 50 Liebert APM with top fan kit	71
Figure 51 UPS main components—typical unit	75
Figure 52 UPS cable connections—45kVA and 90kVA frames	76
Figure 53 Battery cabinet connection to UPS	77
Figure 54 Battery cabinet connection to UPS (continued)	78
Figure 55 Battery cabinet outline drawing, weights and center of gravity, 600mm cabinet ..	79
Figure 56 Battery cabinet outline drawing, weights and center of gravity 900mm cabinet ..	80
Figure 57 Outline drawing, Liebert BDC for Liebert APM, 15-45kVA	81
Figure 58 Outline drawing, Liebert BDC for Liebert APM, 15-90kVA	82
Figure 59 Liebert BDC connection to UPS	83
Figure 60 Acceptable hardware configuration for torque application	84
Figure 61 Seismic mounting bracket details	85
Figure 62 Liebert IntelliSlot Web card display	87
Figure 63 Pin location and numbering	88
Figure 64 Jumper location and numbering	89
Figure 65 Liebert IntelliSlot MultiPort card pin assignment	90
Figure 66 Alber BDSi controller and input connection	91
Figure 67 Multi-temperature sensors	92
Figure 68 Overview of control panel	93
Figure 69 Mimic display indicators location	94
Figure 70 Control button layout	95
Figure 71 Alarm buzzer location	95
Figure 72 Sections of the LCD	96
Figure 73 Menu tree	99
Figure 74 Language selection screen	100
Figure 75 Date and time screen	101
Figure 76 History log records	101
Figure 77 Opening display	102
Figure 78 Default screen	102
Figure 79 Screen saver window	103
Figure 80 Battery start button location	113
Figure 81 Typical configuration for single UPS	117
Figure 82 Liebert APM six-breaker buyout paralleling configuration	118
Figure 83 Dust filter replacement	122
Figure 84 Single module block diagram—Single input configuration with three-breaker Liebert BDC124	

- Figure 85 Single module block diagram—Dual input configuration with three-breaker Liebert BDC125
- Figure 86 Block diagram—Single input configuration with four-breaker internal bypass126
- Figure 87 Battery, circuit breaker and UPS wiring with external batteries with four connecting wires134
- Figure 88 Battery, circuit breaker and UPS wiring with external batteries with three connecting wires134

TABLES

Table 1	Battery voltage, nominal and float.	7
Table 2	Battery retorque values	7
Table 3	LED indications	14
Table 4	Description of dry contact input port	36
Table 5	Output dry contact relays	37
Table 6	Liebert BDC interface	38
Table 7	Battery cabinet interface.	38
Table 8	EPO input contact relays.	39
Table 9	Control wiring for Liebert APM to battery cabinet	59
Table 10	Control wiring for Liebert APM UPS to Liebert BDC	65
Table 11	Center of gravity and weights for Liebert APM 90 kVA frame	72
Table 12	Center of gravity and weights for Liebert APM 45 kVA frame.	73
Table 13	Center of gravity and weights for Liebert APM 90 kVA frame with top fan option.	73
Table 14	Center of gravity and weights for Liebert APM 45 kVA frame with top fan option.	74
Table 15	Interconnect wiring for Liebert APM to battery cabinet.	78
Table 16	Battery cabinet, center of gravity and weights.	79
Table 17	Interconnect wiring for Liebert APM to Liebert BDC.	84
Table 18	Spring washer torque application	84
Table 19	Liebert APM communication options	86
Table 20	Relay card pin configuration	88
Table 21	Jumper connections	89
Table 22	Descriptions of UPS operator control and display panel	93
Table 23	Mimic display status indicators	94
Table 24	Control buttons	95
Table 25	Icons for navigation keys.	97
Table 26	UPS menus and data window items	106
Table 27	Dip switch matrix.	111
Table 28	Mimic indicators after initialization.	111
Table 29	Mimic indicators for normal mode operation with battery breaker open	111
Table 30	Mimic indicators for normal mode operation with battery breaker closed	111
Table 31	UPS operating modes	123
Table 32	Environmental requirements	127
Table 33	UPS mechanical characteristics.	127
Table 34	45kVA Liebert BDC mechanical characteristics	128
Table 35	90kVA Liebert BDC mechanical characteristics	128
Table 36	600mm battery cabinet mechanical characteristics	128

Table 37	Batteries approved for use in External Battery Cabinet, 600mm.....	129
Table 38	Batteries approved for use in External Battery Cabinet, 900mm.....	129
Table 39	Internal batteries approved for use with 45kVA frame Liebert APM.....	129
Table 40	900mm battery cabinet mechanical characteristics.....	129
Table 41	UPS currents and terminals—Input (for single-input unit, 208V operation).....	130
Table 42	UPS currents and terminals—Input (for dual-input unit only, 208V operation)....	130
Table 43	UPS currents and terminals—Bypass input (for dual-input units, 208V operation)... 130	
Table 44	UPS currents and terminals—Battery (288V string).....	131
Table 45	AC/AC efficiency, loss and air exchange.....	131
Table 46	UPS currents and terminals—Output 208V.....	131
Table 47	Battery DC intermediate circuit.....	132
Table 48	Rectifier input.....	132
Table 49	Bypass input.....	133
Table 50	Inverter output to critical load.....	133
Table 51	Component service life.....	136
Table 52	Battery voltage record.....	138
Table 53	Terminal block with compression lugs (for control wiring).....	139
Table 54	Battery retorque values.....	139
Table 55	Recommended test equipment and tools.....	140
Table 56	Hazardous substances or elements.....	141
Table 57	UPS status messages.....	142

IMPORTANT SAFETY INSTRUCTIONS

SAVE THESE INSTRUCTIONS

This manual contains important instructions that should be followed during installation of the Liebert APM, Liebert Bypass Distribution Cabinet™ and batteries (where applicable).

Read this manual thoroughly, paying special attention to the sections that apply to your installation, before working with the UPS. Retain this manual for use by installing personnel.

A properly trained and qualified electrical contractor should oversee the installation of the equipment.

The Liebert APM cannot be put into operation until it is commissioned by the manufacturer or authorized engineer. Otherwise, human safety may be endangered and damage to the UPS will not be covered by the warranty.

The Liebert APM is designed for commercial and industrial uses and cannot be used as life support equipment.

WARNING

Risk of moving heavy equipment and electric shock. Can cause equipment damage, injury and death.

Exercise extreme care when handling UPS cabinets to avoid equipment damage or injury to personnel. The Liebert APM's weight ranges from 800 to 3500 lb. (363 to 1590kg).

Determine unit weight and locate center of gravity symbols before handling the UPS.  Test lift and balance the cabinet before transporting it. Never tilt equipment more than 15 degrees from vertical.

Battery manufacturers supply details of the necessary precautions to be observed when working on, or in the vicinity of, a large bank of battery cells. These precautions should be followed at all times.

Follow all battery safety precautions when installing, charging or servicing batteries. In addition to the hazard of electric shock, gas produced by batteries can be explosive and sulfuric acid can cause severe burns. When connected, the nominal battery voltage is 288VDC and is potentially lethal.

In case of fire involving electrical equipment, use only carbon dioxide fire extinguishers or those approved for use in fighting electrical fires.

Extreme caution is required when performing maintenance.

Be constantly aware that the UPS system contains high DC as well as AC voltages.

Check for voltage with both AC and DC voltmeters prior to making contact.



WARNING

Risk of moving electric shock. Can cause equipment damage, injury and death.

As with other types of high power equipment, dangerous voltages are present within the UPS and battery enclosure even after input power has been disconnected. The risk of contact with these voltages is minimized as the live component parts are housed behind a metal panel. Further internal safety screens make the equipment protected to IP20 standards. Never remove panels or covers or open doors that will expose internal components to contact.

Read and follow all warnings, cautions and safety and operating instructions to avoid serious injury or death from electric shock. No risk exists to any personnel when operating the equipment in the normal manner, following the recommended operating procedures. All equipment maintenance and servicing procedures involve internal access and should be carried out only by trained personnel.

Ground Leakage Currents



CAUTION

Risk of electric shock from high leakage current. Can cause injury, property damage and death.

EARTH CONNECTION IS ESSENTIAL BEFORE CONNECTING THE INPUT SUPPLY.

Earth leakage current exceeds 3.5 mA and is less than 1000 mA.

Transient and steady-state earth leakage currents, which may occur when starting the equipment, should be taken into account when selecting instantaneous RCCB or RCD devices.

Residual Current Circuit Breakers (RCCBs) must be selected sensitive to DC unidirectional pulses (Class A) and insensitive to transient current pulses.

Note also that the earth leakage currents of the load will be carried by this RCCB or RCD. This equipment must be earthed in accordance with the local electrical code of practice.



WARNING

Risk of electric shock. Can cause injury, property damage and death.

Under typical operation and with all UPS doors closed, only normal safety precautions are necessary. The area around the UPS system should be kept free of puddles of water, excess moisture and debris.

Special safety precautions are required for procedures involving handling, installation and maintenance of the UPS system and the internal batteries (internal batteries accommodated by 45kVA frame only). Observe all safety precautions in this manual before handling or installing the UPS system as well as during all maintenance procedures. Observe all battery safety precautions before working on or near the battery.

This equipment contains several circuits that are energized with high voltage. Only test equipment designed for troubleshooting should be used. This is particularly true for oscilloscopes. Always check with AC and DC voltmeters to ensure safety before making contact or using tools. Even when the power is turned Off, dangerously high electric charges may exist within the UPS.

All power and control wiring should be installed by a qualified electrician. All power and control wiring must comply with the NEC and applicable local codes.

ONLY qualified service personnel should perform maintenance on the UPS system. When performing maintenance with any part of the equipment under power, service personnel and test equipment should be standing on rubber mats. The service personnel should wear insulating shoes for isolation from direct contact with the floor (earth ground).

Never work alone, even if all power is removed from the equipment. A second person should be standing by to assist and summon help in case an accident should occur.

NOTICE

Risk of improper ground connection. Can cause equipment damage.

Ground connection is essential before connecting the input supply. This equipment must be grounded in accordance with local electrical codes. Maximum load must not exceed that shown on the UPS rating label.

NOTICE

Risk of improper electromagnetic shielding. Can cause radio communication interference.

This unit complies with the limits for a Class A digital device, pursuant to Part 15 Subpart J of the FCC rules. These limits provide reasonable protection against harmful interference in a commercial environment. This unit generates, uses and radiates radio frequency energy and, if not installed and used in accordance with this instruction manual, may cause harmful interference to radio communications.

This unit is not designed for use in a residential area. Operation of this unit in a residential area may cause harmful interference that the user is solely responsible for correcting.

Battery Cabinet Precautions

The following warning applies to all battery cabinets supplied with UPS systems. Additional warnings and cautions applicable to battery cabinets may be found in **5.0 - Battery Installation**.



WARNING

Risk of improper handling. Can cause injury, property damage and death. Internal battery strapping must be verified by manufacturer prior to moving a battery cabinet (after initial installation).

- Battery cabinets contain non-spillable batteries.
- Keep units upright.
- Do not stack.
- Do not tilt.

Failure to heed this warning could result in smoke, fire or electric hazard.

Call 1-800-543-2378 before moving battery cabinets (after initial installation).

Battery Hazards



WARNING

Risk of electric shock. Can cause injury, property damage and death.

Special care should be taken when working with the batteries associated with this equipment. Batteries are always live. Battery terminal voltage will exceed 300VDC and is potentially lethal.

In addition to the hazard of electric shock, gas produced by batteries can be explosive and sulfuric acid can cause severe burns.

Batteries should be installed, serviced and replaced only by properly trained and qualified service personnel trained in safe battery handling methods and who have the correct PPE (Personal Protection Equipment) and tools.











The following precautions should be observed when working with the batteries:

- Eye protection should be worn to prevent injury from electrical arcs.
- Remove rings, watches and all other metal objects.
- Use only tools with insulated handles.
- Wear rubber gloves and boots.
- When replacing batteries, replace them with the same type and number of batteries or battery packs.
- Do not dispose of batteries in a fire. The batteries may explode.
- Do not open or mutilate batteries. Released electrolyte is harmful to the skin and eyes. It is toxic.
- Never lay metal objects of any type on top of the batteries.
- Disconnect the charging source before connecting or disconnecting battery terminals.
- Determine whether the battery is grounded. If the battery is grounded, remove source of the ground. Contact with any part of a grounded battery can result in electrical shock. The likelihood of such shock can be reduced if such grounds are removed during installation and maintenance.

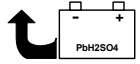
If a battery leaks electrolyte, or is otherwise physically damaged, it must be replaced, stored in a container resistant to sulfuric acid and disposed of in accordance with local regulations.

If electrolyte comes into contact with skin, the affected area should be washed immediately with large amounts of water.

GLOSSARY OF SYMBOLS

	Risk of electrical shock
	Indicates caution followed by important instructions
	AC input
	AC output
	Requests the user to consult the manual
	Indicates the unit contains a valve-regulated lead acid battery
	Recycle
	DC voltage
	AC voltage
	Equipment grounding conductor
	Bonded to ground

1.0 INTRODUCTION

The Liebert APM UPS is a transformer-free, hardware-scalable, online uninterruptible power system with 208/120V input and 208/120V output capability. The Liebert APM can operate with either a 50 or 60Hz input and provide a matching output frequency conversion. The rack-mounted 15kVA/kW modules allow scaling the UPS's capacity in 15kVA increments from 15kVA to a maximum of 90kVA in a single frame.

Optional transformers are available to add 208V Isolation or 480V or 600V input capability to the Liebert APM in both the UPS, 90kVA/kW frame only, or the Bypass Distribution Cabinet (BDC) in either the 45kVA/kW or the 90kVA/kW frame.

The Liebert APM UPS is a SmartAisle™ technology, appropriate for use with the SmartAisle design approach.

The Liebert APM provides continuous, high-quality AC power to business-critical equipment, such as telecommunications and data processing equipment. The Liebert APM supplies power free of the disturbances and variations in voltage and frequency common to utility power, which is subject to brownouts, blackouts, surges and sags.

The Liebert APM utilizes the latest in high-frequency, double-conversion pulse width modulation (PWM) technology and fully digital controls to enhance its reliability and increase the ease of use.

Two frame sizes are available: 45kVA/kW and 90kVA/kW. The 45kVA/kW frame is designed to accept internal batteries; the 90kVA/kW frame does not. The 90kVA frame is, however, designed to accept Internal Transformers and a four-breaker bypass.

Output Voltage Adjustment

This feature allows a Liebert Customer Engineer to adjust the output voltage over a range of -5% to +16% of nominal. This permits compensation for any IR drop when the UPS is a significant distance from the protected load. Output voltage adjustment can optimize the UPS output voltage for loads that operate more efficiently at a UPS output voltage different from the Liebert APM's standard output voltage.

1.1 Battery Maintenance



WARNING

Risk of electrical shock and high short circuit current. Can cause equipment damage, personal injury and death.

These maintenance procedures will expose hazardous live parts. Refer servicing to properly trained and qualified personnel working in accordance with applicable regulations as well as with manufacturers' specifications.

1.1.1 Battery Safety Precautions

Servicing of batteries should be performed or supervised by personnel knowledgeable of batteries and the required precautions. Keep unauthorized personnel away from batteries. When replacing batteries, use the same number and type of batteries.

WARNING

Risk of electric shock, explosive reaction, hazardous chemicals and fire. Can cause equipment damage, personal injury and death.

Lead-acid batteries contain hazardous materials. Batteries must be handled, transported and recycled or discarded in accordance with federal, state and local regulations. Because lead is a toxic substance, lead-acid batteries must be recycled rather than discarded.

Do not dispose of battery or batteries in a fire. The battery may explode.

Do not open or mutilate the battery or batteries. Released electrolyte is harmful to the skin and eyes. It is toxic.

WARNING

Risk of electrical shock and high short circuit current. Can cause equipment damage, personal injury and death.

The following precautions must be observed when working on batteries:

- Remove watches, rings and other metal objects.
- Use tools with insulated handles.
- Wear rubber gloves and boots.
- Do not lay tools or metal parts on top of batteries.
- Disconnect charging source prior to connecting or disconnecting battery terminals.
- Determine whether the battery is grounded. If it is grounded, remove source of ground. Contact with any part of a grounded battery can result in electrical shock. The likelihood of such shock will be reduced if such grounds are removed during installation and maintenance.

Lead-acid batteries can present a risk of fire because they generate hydrogen gas. In addition, the electrical connections must be protected against accidental short circuits which can cause sparks. The following procedures should be followed:

- DO NOT SMOKE when near batteries.
- DO NOT cause flame or spark in battery area.
- Discharge static electricity from body before touching batteries by first touching a grounded metal surface.
- After replacing battery jars in a battery cabinet, replace the retaining straps that hold the jars in place on the shelves. This will limit accidental movement of the jars and connectors should the cabinet ever need to be repositioned or relocated.

Regular maintenance of the battery module is an absolute necessity. Periodic inspections of battery and terminal voltages, specific gravity and connection resistance should be made. Strictly follow the procedures outlined in the battery manufacturer's manual, available on the manufacturer's Web site.

Valve-regulated lead-acid (sealed-cell) batteries do require periodic maintenance. Although maintenance of electrolyte levels is not required, visual inspections and checks of battery voltage and connection resistance should be made.

NOTICE

Risk of equipment damage. Batteries should be cleaned with a dry cloth or a cloth lightly moistened with water. Do not use cleaners on the batteries. Solvents can make the battery cases brittle.

Because individual battery characteristics are not identical and may change over time, the UPS module is equipped with circuitry to equalize battery cell voltages. This circuit increases charging voltage to maintain flooded type battery cells at full capacity.

WARNING

Risk of electric shock, explosive reaction, hazardous chemicals and fire. Can cause equipment damage, personal injury and death.

Do not use equalize charging with valve-regulated, lead-acid batteries, such as those in Liebert Battery Cabinets. Refer to the battery manufacturer’s manual, available on the manufacturer’s Web site, for specific information about equalize charging.

Matching Battery Cabinets—Optional

Although the individual battery cells are sealed (valve-regulated) and require only minimal maintenance, the Battery Cabinets should be given a periodic inspection and electrical check. Checks should be performed at least annually to ensure years of trouble-free service.

Voltage Records: With the Battery Cabinet DC circuit breaker closed and the connected UPS operating, measure and record battery float voltage. With the DC circuit breaker open, measure and record the nominal (open circuit) voltage. Both these measurements should be made across the final positive and negative terminal lugs. Compare these values with those shown below. The recorded nominal voltage should be no less than the value shown; while the recorded float voltage should be within the range shown. If a discrepancy is found, contact Vertiv.

Table 1 Battery voltage, nominal and float

Number of Cells	Battery Voltage, VDC	
	Nominal/ Open Cell	Float
144	288	324

Power Connections: Check for corrosion and connection integrity. Inspect wiring for discolored or cracked insulation. Clean and/or retighten as required. Refer to torque specifications in **Table 2**.

Battery Cell Terminals: Check for discoloration, corrosion and connection integrity. Clean and tighten if necessary. Note that when installing a new battery, the initial torque value is 5 lb.-in. more than the retorquer value. **Table 2** shows battery retorquer values.

Table 2 Battery retorquer values

Battery Mfr.	Battery Model #	Retorquer Value
Energys	HX205-FR	65 in-lb
	HX300-FR	65 in-lb
	HX330-FR	65 in-lb
	HX400-FR	65 in-lb
	HX500-FR	65 in-lb
	HX540-FR	65 in-lb
	16HX800F	100 in-lb
	16HX925F	100 in-lb

If the system uses a different model battery, contact Vertiv for the required torque value.

To access battery cell terminals, disconnect the inter-tier cable and two shelf retaining screws. Once disconnected, insulate (with protective boot or electrical tape) the cables to prevent accidental shorts. The battery shelf can now be pulled out. Tighten each terminal connection to the retorquer value. When replacing a battery, the terminal connections must be cleaned and

tightened. Disconnect and insulate the cables connected to the battery. Secure each battery shelf with retaining screws when maintenance is complete.

Other DC Sources

If the UPS system uses a DC source other than a factory-supplied Matching Battery Cabinet, perform maintenance on the DC source as recommended in the DC source manufacturer's maintenance manual, available on the manufacturer's Web site.

2.0 INSTALLATION

This section describes the Liebert APM's environmental requirements and mechanical considerations that must be taken into account when planning the positioning and cabling of the UPS equipment.

Because each site is unique, this section presents a guide to general procedures and practices that should be observed by the installing engineer, rather than step-by-step installation instructions.



WARNING

Risk of electric shock. Can cause injury, property damage and death.

Special care should be taken when working with the batteries associated with this equipment. When connected together, the nominal battery voltage is 288VDC and is potentially lethal.

- Eye protection should be worn to prevent injury from accidental electrical arcs.
- Remove rings, watches and all metal objects.
- Only use tools with insulated handles.
- Wear rubber gloves.

If a battery leaks electrolyte or is otherwise physically damaged, it must be replaced, stored in a container resistant to sulfuric acid and disposed of in accordance with local regulations.

If electrolyte comes into contact with skin, the affected area should be washed immediately with large amounts of water.

NOTICE

Risk of improper installation. Can cause equipment damage.

Do not apply electrical power to the UPS equipment before the commissioning engineer arrives at the installation site.

The UPS must be installed by a properly trained and qualified engineer in accordance with the information contained in this chapter. All the equipment not referred to in this manual is shipped with details of its own mechanical and electrical installation information.



NOTE

Three-phase, four-wire input power is required.



NOTE

Input power must be supplied to the Liebert APM from a properly grounded Wye or Delta source. The Liebert APM is not for use with impedance grounded systems, corner-grounded systems or high-leg Delta systems. For these applications, an isolation transformer must be installed between the input power and the Liebert APM.

2.1 Initial Inspections

1. While the Liebert APM and ancillary cabinets are still on the truck, inspect the equipment and shipping container for any signs of damage or mishandling. Do not attempt to install the system if damage is apparent. If any damage is noted, file a damage claim with the shipping agency immediately and contact Vertiv at 1-800-543-2378 to inform them of the damage claim and the condition of the equipment.
2. Compare the contents of the shipment with the bill of lading. Report any missing items to the carrier and your local Vertiv representative immediately.
3. Check the product label on the back of front door and confirm the contents match the UPS model, capacity and main parameters that were ordered.

2.1.1 Storing for Delayed Installation

If the equipment will not be installed immediately, it must be stored indoors where the humidity is no higher than 90% and the temperature is no higher than 104°F (40°C). The storage area must protect the Liebert APM from excessive moisture (see **11.2 - UPS Environmental**).



CAUTION

If the UPS must remain disconnected from power for more than six (6) months, the batteries (if so equipped) must be recharged before use. To charge the batteries, the unit must be connected to utility power and started up—the charger operates only while the Liebert APM is operating.



CAUTION

When batteries are installed in the UPS or are cabinet-mounted adjacent to the UPS, the battery—not the UPS—dictates the designed maximum ambient temperature.

2.2 Preliminary Checks

2.2.1 Identification

The equipment supplied has an identification tag on the back of the main door listing the type and size of the UPS.

2.3 UPS Location

2.3.1 Positioning the UPS

Choose a location for the UPS that offers:

- Easy connection to inputs, outputs and auxiliary equipment
- Enough space to service the UPS
- Air circulation sufficient to expel heat produced by UPS
- Protection against moisture and excessive humidity
- Protection against dust and other particulate matter
- Compliance with fire prevention regulations and practices
- Operating environment temperature of 74-80°F (23-27°C) for maximum battery efficiency

2.3.2 Environmental Considerations

Before installing the Liebert APM, verify that the UPS room satisfies the environmental conditions stipulated in **11.2 - UPS Environmental**, paying particular attention to the ambient temperature and air exchange system.

The UPS unit should be installed in a cool, dry, clean-air environment with adequate ventilation to keep the ambient temperature within the specified operating range 32°F to 104°F (0°C to 40°C).

For optimal UPS and battery system performance and service life, maintain the operating temperature within the range of 74-80°F, (23-27°C).

The Liebert APM is cooled by internal fans. Cooling air enters the unit through the front of the unit and is exhausted out the back. To permit proper air flow and prevent overheating, do NOT block or cover the ventilation openings or blow air down onto the unit. The UPS requires 24 in. (610mm) ventilation clearance above the unit and 12" (305mm) behind the UPS.

See **Table 46** for details on heat dissipation.

Battery Location

Temperature is a major factor in determining battery life and capacity. Battery manufacturers recommend an operating temperature of 77°F (25°C). Ambient temperatures warmer than this reduce battery life; temperatures below this reduces battery capacity. In a typical installation, battery temperature should be maintained between 74°F and 80°F (23-27°C). Batteries should be placed where there are no main heat sources or air inlets to prevent portions of batteries from being either much warmer or much cooler than other parts of the batteries.

2.4 Considerations in Moving the Liebert APM

Ensure that the UPS weight is within the designated surface weight loading (lb./ft² or kg/cm²) of any handling equipment. See **Table 33** for weights of various units.

The Liebert APM may be rolled on its casters for short distances only. For longer distances, move the UPS with a forklift or similar equipment to ease the relocation and to reduce vibration. The optional battery cabinets should be moved with a forklift or similar equipment.



WARNING

Risk of moving heavy unit. Can cause property damage, injury and death.

Ensure that any equipment that will be used to move the Liebert APM has sufficient lifting capacity. The Liebert APM's weight ranges from 800 to 3500 lb. (363 to 1590kg). See **Table 33** for details.

The UPS presents a tipping hazard. Do not tilt the Liebert APM more than 15 degrees from vertical.

The UPS is fitted with casters—Take care to prevent movement when unbolting the equipment from its shipping pallet. Ensure adequate personnel and lifting equipment are available when taking the Liebert APM off its shipping pallet.



WARNING

Risk of heavy unit tipping over while being moved. Can cause property damage, injury and death.

The casters are strong enough for movement across even surfaces only. Casters may fail if they are subjected to shock loading, such as being dropped or rolled over holes in the floor or obstructions. Such failure may cause the unit to tip over, injuring personnel and damaging the equipment.

Care must be taken when maneuvering units fitted with batteries. Keep such moves to a minimum. For further information, see **Battery Cabinet Precautions on page 4**.

Final Positioning

When the equipment has been finally positioned, ensure that the adjustable stops are set so that the UPS will remain stationary and stable (see **7.0 - Installation Drawings**).

The Liebert APM and its auxiliary cabinets must be installed on a concrete or equivalent, non-resilient floor.

2.5 Mechanical Considerations

The Liebert APM is constructed with a steel frame and removable panels. Top and side panels are secured to the chassis by screws. The doors may be opened for access to power connections bars, auxiliary terminals blocks and power switches.

The UPS comes with an Operator Control Panel that provides basic operational status and alarm information. The cabinet houses both the power components and the internal batteries. Cooling is provided by internal fans. The unit sits on four casters. Adjustable stops are provided to prevent the UPS from moving once it has been moved to its final position.

WARNING

Risk of heavy units tipping over while being moved. Can cause property damage, injury and death.

The Liebert BDC™ and battery cabinets must be properly prepared and secured for lifting. Improper lifting may cause the cabinets to fall, causing personal injury or death and equipment damage.

Vertiv recommends lifting the units with one of the following methods:

- Installing four eyebolts in the factory-fabricated holes, one at each corner of the unit, attaching cables or similar strapping to the eyebolts and lifting with a suitable mechanism.
- Placing suitable straps on the Liebert BDC™ or battery cabinet. The straps must go under the unit to be lifted.

2.5.1 Clearances

There are no ventilation grilles on the sides of the UPS. The sides must be accessible during installation. After installation, the unit must have a clearance of 12 in. (305mm) in the rear to permit adequate circulation of air exhausted from the UPS. The Top Fan option eliminates the 12" (305mm) rear clearance requirement, but it increases the Liebert APM's height by 7.63" (194mm).

To enable routine tightening of power terminations within the UPS, make sure there is sufficient clearance in front of the Liebert APM to permit free passage of personnel with the door fully opened.

Leave a minimum of 24 in. (610mm) between the top of the UPS frame and the ceiling to permit adequate air circulation above the unit. Vertiv recommends against using air conditioning or other systems that blow air onto the top of the unit.

2.5.2 Floor Installation

If the Liebert APM, Liebert BDC or battery cabinet is to be placed on a raised floor, the UPS should be mounted on a pedestal that will support the equipment point loading. Refer to the bottom view in **Figures 49,55 or 58** to design this pedestal.

2.5.3 Cable Entry

Cables can enter the Liebert APM, Liebert BDC and battery cabinets from the top or bottom through removable metal plates.

Some plates have factory-punched holes and others are designed to allow the personnel to punch holes for fitting and securing the conduit. Once the conduit holes are punched, these plates should be reattached to the UPS. The conduit size and wiring method must be in accordance with all local, regional and national codes and regulations, including NEC ANSI/NFPA 70.

The UPS must be accessible from the right side to allow personnel to complete the cable connections and make necessary adjustments. After installation is complete, the Liebert APM may be serviced from the front.

**NOTE**

When installing the UPS, the customer must provide a disconnect with overcurrent protection at the output of the UPS.

2.5.4 Special Considerations for Parallel Systems

1. Consider the grounding configuration of the UPS system before finalizing module placement. For optimal ground performance, the Liebert APM modules should be close together. See **3.2.6 - Cabling Guidelines**.
2. For optimal load-sharing performance, the UPS bypass input cables and output cables should be approximately the same length, ± 10 percent.
3. Position modules in such a way as to minimize the length of power cables and control wiring between UPS modules and the paralleling cabinet.

Refer to **4.0 - Parallel System and LBS System Installation** for further information on installing a parallel system.

2.5.5 Special Considerations for 1+N Parallel Systems

Consider the grounding configuration of the UPS system before finalizing module placement. See **3.2.6 - Cabling Guidelines**.

Vertiv recommends matching the impedance in the bypass path of paralleled systems as closely as possible.

The impedance mismatch can be minimized by controlling the wiring length of each unit. The design and the layout of the UPS system and associated panels and cabling should be examined closely to ensure that cable lengths and impedances are closely matched. The Liebert 1+N UPS module is supplied with a sharing reactor to minimize the impact of cable impedance mismatch. The cabling impedance must be carefully controlled to ensure good bypass current sharing.

For Liebert APM systems, the cabling impedances must be within 10% from maximum to minimum. If the cabling impedances must be greater than 10%, contact your Vertiv representative to calculate whether the system will result in an overload condition when operating on bypass.

When bringing the 1+N system online for the first time or after removing one unit, Vertiv recommends checking the bypass current mismatch. To check the bypass current mismatch:

1. Place a load on the bypass of each UPS module.
2. View the output current of each unit.

The accuracy of the currents displayed on the UPS module is sufficient for this check. If the mismatch is greater than 10%, the bypass impedances must be balanced or the load must be limited to less than the maximum rating.

2.6 45kVA and 90kVA UPS Frames—Auxiliary Cabinets

The 45kVA frame consists of a single cabinet housing the UPS components and the internal battery string. The 90kVA frame, also a single cabinet, does not accommodate internal batteries, but does provide for an internal four-breaker bypass or an internal transformer. The internal transformers are available with 480V:208V; 600V:208V; or 208V:208V isolation input primaries.

Optional battery cabinets are available for each Liebert APM model to provide extended run time. Each battery cabinet houses a single string of batteries per cabinet that operate in parallel with the Liebert APM's internal batteries (45kVA frame only). The battery cabinets are designed to be bolted to the left side of the UPS (see **Figure 1**). Refer to **5.4 - External Battery Cabinet Installation** for details.

Optional Liebert BDC™ units are available. These cabinets house the components necessary to provide an external wraparound maintenance bypass switch for servicing the UPS.

Liebert BDCs are designed to be bolted to the right side of the UPS (see **Figure 1**). Refer to **6.4 - Locating the Cabinet** for further details.

System Composition

A UPS system can comprise a number of equipment cabinets, depending on the system design requirements—e.g., UPS cabinet, External Battery Cabinet and External Bypass Cabinet. All cabinets used will be the same height and will be designed to be positioned side-by-side to form an aesthetically appealing equipment suite.

2.6.1 Optional Cabinets

If the Liebert APM installation includes a Liebert BDC, the UPS must be positioned to allow the Liebert BDC to be bolted to right side of the Liebert APM (see **Figure 1**).

The Liebert BDC must be cabled and bolted to the Liebert APM before the UPS and bypass cabinet are moved into their final position. Connect the input wiring to the Liebert BDC ONLY after the units are connected and positioned.

Battery cabinets may be bolted only to the left side of the Liebert APM; see **Figure 1**.

Figure 1 Cabinet arrangement

ALL UNITS VIEWED FROM ABOVE

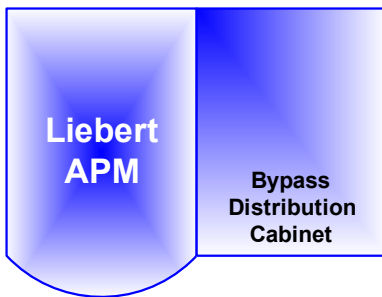

Liebert APM connected only to Liebert BDC
(BDC must be on right side of the Liebert APM)

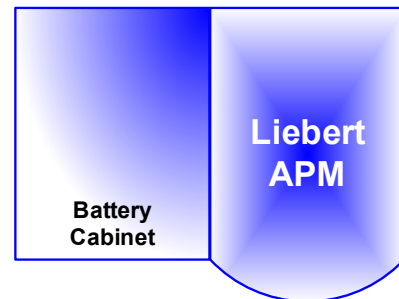

Liebert APM connected to Battery Cabinet (Battery Cabinets
must be on the left side of the Liebert APM)

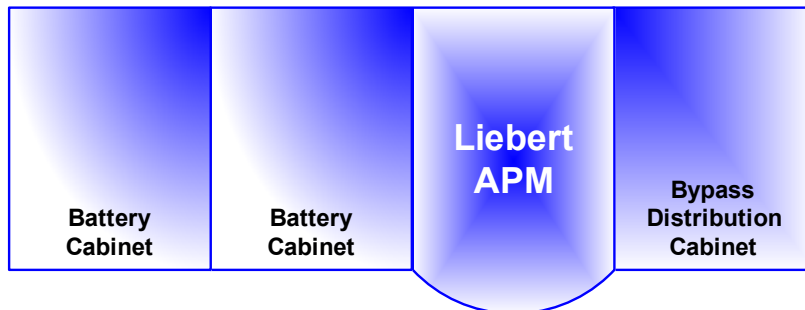

Liebert APM connected to Liebert BDC and Battery Cabinets
(BDC must be on right side of the Liebert APM)
(Battery Cabinets must be on the left side of the Liebert APM)

2.7 Optional Seismic Brackets

Optional seismic mounting brackets to anchor the Liebert APM, Liebert BDC™ and battery cabinet to the floor are available. Refer to **Figure 61** for mounting details.

2.8 Liebert FlexPower™ Assembly

Figure 2 Liebert FlexPower assembly indicators and controls

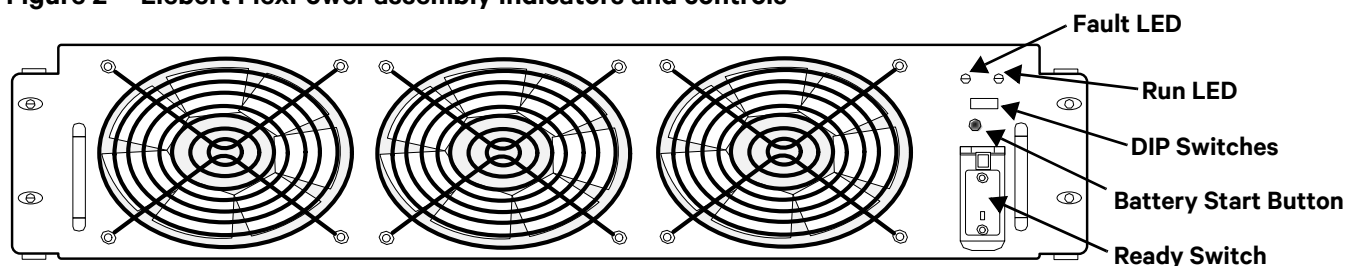

The Battery start button allows starting of UPS on battery; refer to **10.3 - UPS Battery Start**.

The Run LED is illuminated Green when the Liebert FlexPower assembly is operating normally.

The Fault LED will illuminate red when the Liebert FlexPower assembly has a problem.

Table 3 LED indications

LED Status	Indication
Run LED (Green)	
Flashing Green	The inverter is starting, but has no output yet.
Constant Green	The inverter has started to supply power.
OFF	The inverter has not started up.
Fault LED (Red)	
Constant Red	Auxiliary power failure (15V or 24V), rectifier overtemperature, rectifier failure (including battery SCR short circuit), battery converter failure, soft start failure, main circuit back feed, abnormal input current, inverter failure, output short circuit, bypass SCR short circuit fault, inverter relay short circuit fault, abnormal bus voltage under non-sleep mode, module not ready, module ID out of range and duplicated module ID.
Flashing Red	Charger failure, abnormal main circuit voltage, abnormal main circuit frequency, main circuit undervoltage, main circuit reverse phase, battery unavailable, reverse battery, input zero-loss, current sharing failure, module overload, inverter relay disconnection fault, bypass SCR disconnection fault and input fuse blown.
OFF	No above failures or alarms.

2.9 Static Bypass Assembly

Figure 3 Static bypass assembly connections

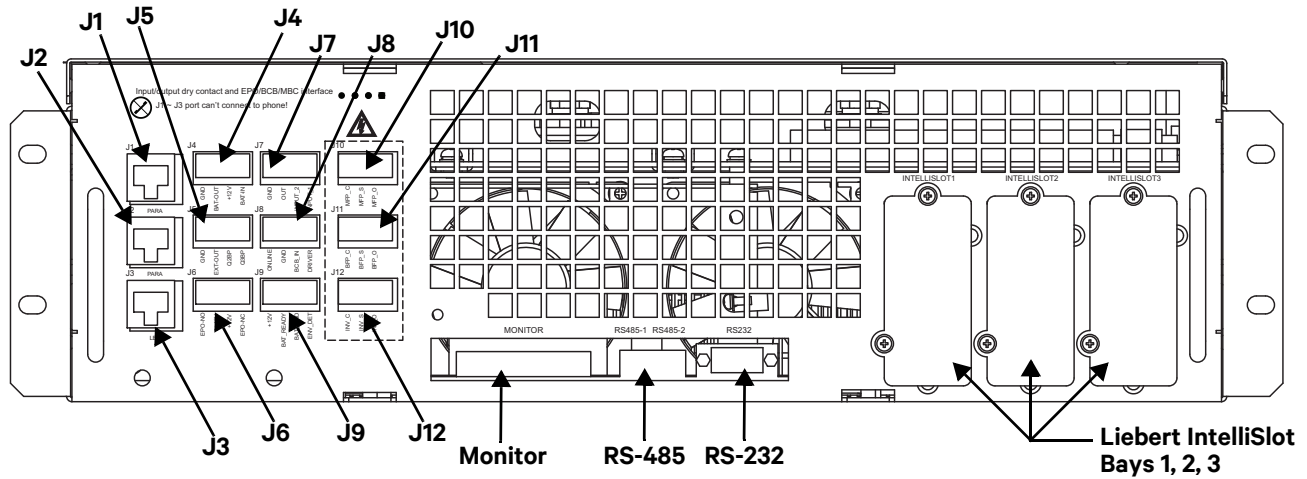

The Static bypass assembly has three Liebert IntelliSlot interface card bays and connections for ancillary cabinets (Liebert BDC and battery) and for options.

3.0 ELECTRICAL CONNECTIONS—UPS

The UPS requires both power and control cabling once it has been mechanically installed. All control cables must run separate from power cables in metal conduits or metal ducts that are electrically bonded to the metalwork of the cabinets to which they are connected.

WARNING

Risk of electric shock. Can cause property damage, injury and death.

Before connecting input power to the Liebert APM, ensure that you are aware of the location and operation of the overcurrent protection devices that connect the UPS input/bypass supply to the power distribution panel.

De-energize and lockout or tagout all incoming high- and low-voltage power circuits before installing cables or making any electrical connections.

3.1 Power Cabling

3.1.1 Cable Rating

The main factors affecting the choice and size of cable are voltage, current (also taking into account overcurrent), room temperature and conditions of installation of the cable. Refer to ANSI/NFPA 70.

The power cables of the system must be sized with respect to the following description:

- UPS input cables - The UPS input cables must be sized for the maximum input current, including the maximum battery recharge current, given in **Table 41**, with respect to the unit rating and the input AC voltage.
- UPS bypass and output cables - The bypass and output cables must be sized for the nominal output current, given in **Table 41**, with respect to the unit rating and the output AC voltage.
- Battery cables - Each UPS unit has its own internal batteries factory-wired. If connecting an external battery cabinet, the battery cables must be sized for the battery discharge current at the end-of-discharge voltage, as given in **Table 41**, with respect to the unit rating.



NOTE

Table 41 gives nominal currents for determining the size of UPS power cables. Other important factors to consider include cable route length and coordination with protective devices.

The power cables can be sized to suit the UPS unit rating according to **Table 41**.

Lug Size and Torque Requirements

Refer to **Table 41** for lug size and torque requirements and to **Table 18** and **Figure 60**.

3.2 External Protective Devices

For safety concerns, it is necessary to install external circuit breakers or other protective devices for the input AC supply of the UPS system. This section provides generic practical information for qualified installation engineers. The installation engineers should be knowledgeable about regulatory wiring standards and the equipment to be installed.

To reduce the risk of fire, connect only to a circuit provided with branch circuit overcurrent protection in accordance with NEC ANSI/NFPA 70.

3.2.1 Rectifier and Bypass Input Supply of the UPS

Overcurrents

Install suitable protective devices in the distribution unit of the incoming mains supply, considering the power cable current-carrying capacity and overload capacity of the system. Generally, the magnetic circuit breaker with IEC60947-2 tripping curve C (normal) at the 125% of the nominal current listed in **Table 41** is recommended.

Split bypass: In case a split bypass is used, separate protective devices should be installed for the rectifier input and bypass input in the incoming mains distribution panel.



NOTE

The rectifier input and bypass input must use the same neutral line.

For an IT power network system, a 4-pole protective device must be installed on the external input distribution and external output distribution of the UPS.

Earth Leakage, RCD Devices

Any residual current detector (RCD) installed upstream of the UPS input supply:

- Must be sensitive to DC unidirectional pulses (Class A)
- Must be insensitive to transient current pulses, and
- Must have an average sensitivity, adjustable between 0.3 and 1A.

To avoid false alarms, earth leakage monitoring devices when used in systems with split bypass input or when used in paralleled UPS configurations, must be located upstream of the common neutral sinking point. Alternatively, the device must monitor the combined four-wire rectifier and split bypass input currents.

The residual earth current introduced by the RFI suppression filter inside the UPS is greater than 3.5mA and less than 300mA. Liebert recommends verifying the selectivity with all other differential devices both upstream of the input distribution board and downstream (toward the load).

3.2.2 External Battery

The DC-compatible circuit breaker provides overcurrent protection for UPS system and battery, which is provided by the external battery cabinet.

3.2.3 UPS Output

If an external distribution panel is used for load distribution, the selection of protective devices must provide discrimination with those that are used at the input to the UPS (see **Table 47**).

3.2.4 UPS Input Configuration

By default, the Liebert APM ships with internal links installed between the bypass input and main (rectifier) input (single input configuration see **Figure 83**).

Figure 4 shows the Liebert APM in a split bypass (single source dual-input) configuration. In this configuration, the static bypass and the maintenance bypass lines are supplied by the same source using separate feeds. Both feeds must be protected externally with properly sized protective devices.

To wire the Liebert APM as a single source dual-input UPS, remove the links and wire the bypass feed to the bypass busbars, then wire the main feed to the main busbars (see **Figure 8**).

Figure 4 Single UPS block diagram—dual input single source configuration

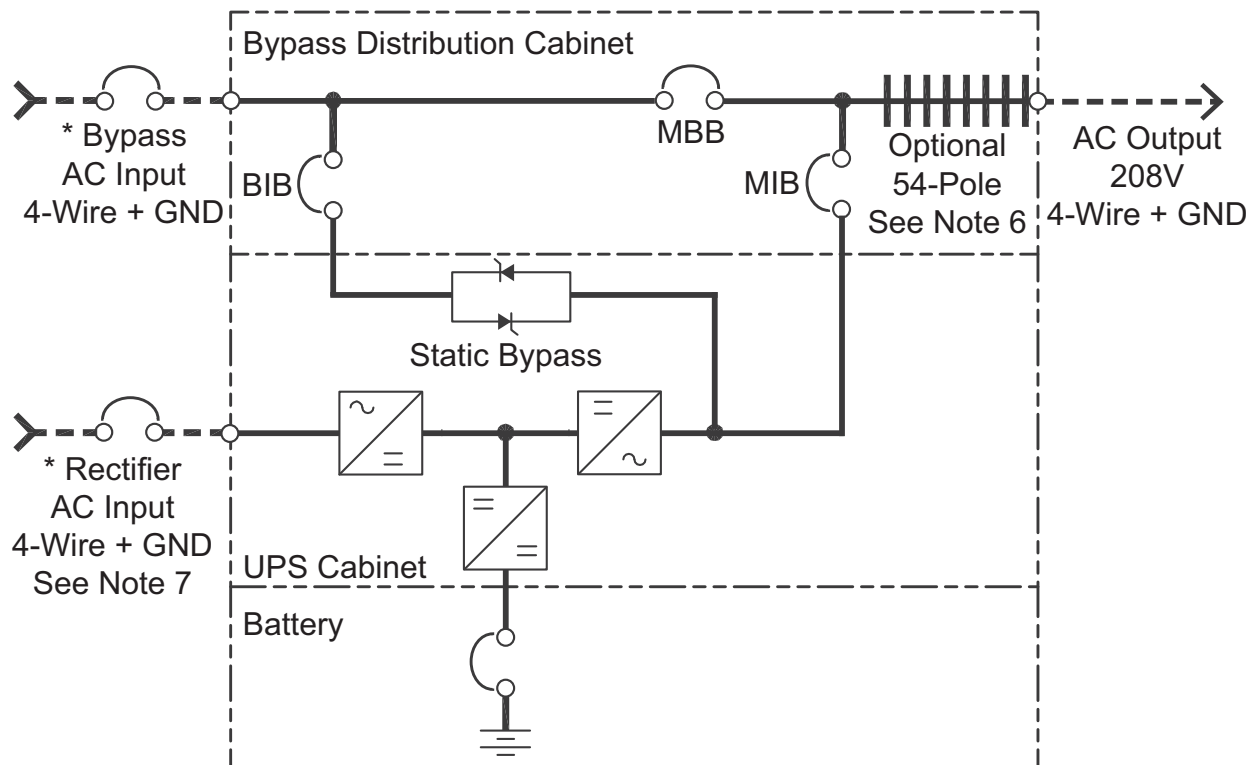

NOTES

1. Install in accordance with national and local electrical codes.
2. Input and bypass must share the same single source.
3. A neutral is required from the system AC input source. A full capacity neutral conductor is recommended. Grounding conductors are recommended.
4. Bypass and rectifier inputs and output cables must be run in separate conduits.
5. Control wiring must be run in separate conduits.
6. Optional 54-pole, 225A for 45kVA frame only or optional 54-pole, 400A for 90kVA frame only.
7. Customer must supply shunt trip breaker with 120V coil.

BIB - Bypass Isolation Breaker
 MBB - Maintenance Bypass Breaker
 MIB - Maintenance Isolation Breaker
 * External Overcurrent Protection by others

----- Field-Supplied Wiring

UAM01023
 Rev. 3

3.2.5 UPS Input Configuration with Transformers

Figure 5 shows the Liebert APM in a split bypass (single-source, dual-input) configuration using two transformers. One transformer is inside the Bypass Distribution Cabinet and the other inside the UPS.

In this configuration, the static bypass and the maintenance bypass lines are supplied by the same source using separate feeds. Both feeds must be protected externally with properly sized protective devices.

Figure 6 shows the control wiring for the dual input transformer configuration.

Figure 5 Liebert APM in a split bypass configuration

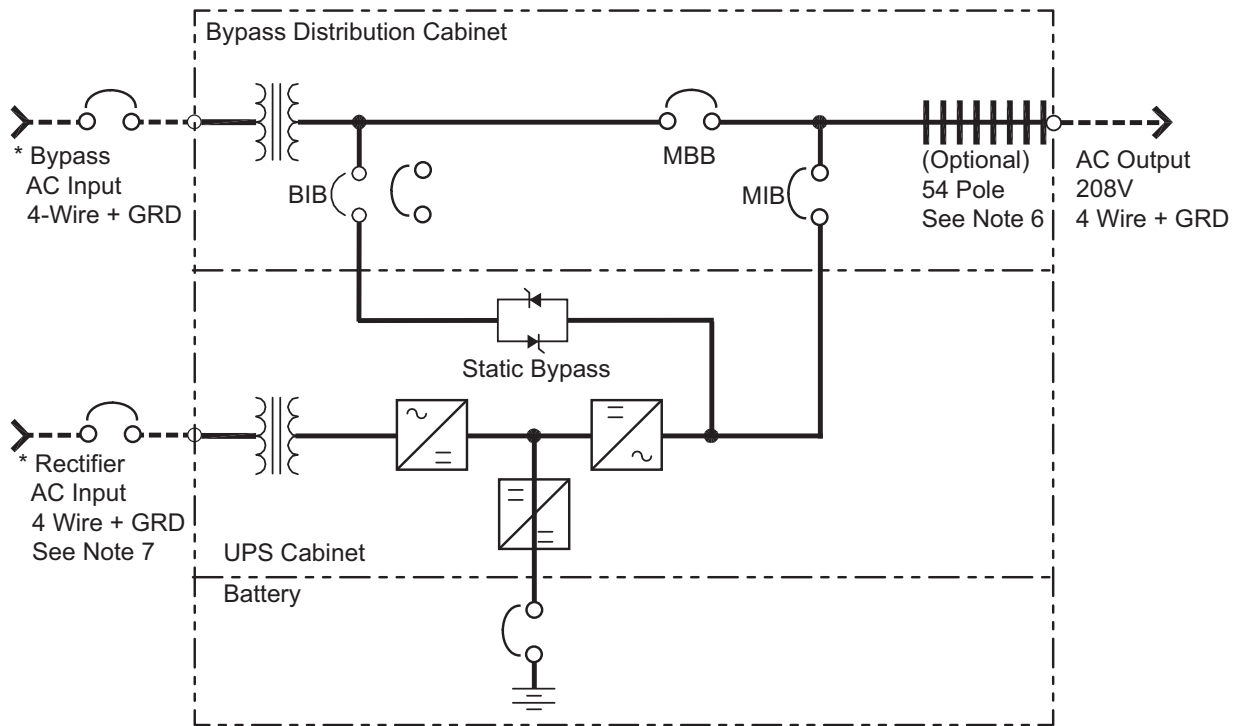

NOTES:

1. Install in accordance with national and local electrical codes.
2. Input and bypass must share the same single source.
3. A neutral is required from the system AC input source. A full capacity neutral conductor is recommended. Grounding conductors are recommended.
4. Bypass and rectifier inputs and output cables must be run in separate conduits.
5. Control wiring must be run in separate conduits.
6. Optional 54 pole, 225A for 45kVA frame only or optional 54 pole 400A for 90kVA frame only.
7. Customer must supply shunt trip breaker with 120V coil.
8. Input voltage options of the isolation transformer: 600V, 480V, 220V and 208V.

BIB - Bypass Isolation Breaker
 MBB - Maintenance Bypass Breaker
 MIB - Maintenance Isolation Breaker

* External Overcurrent Protection by Others

----- Field-Supplied Wiring

UAM01024
 Rev. 0

Figure 6 Control wiring for the dual input transformer configuration

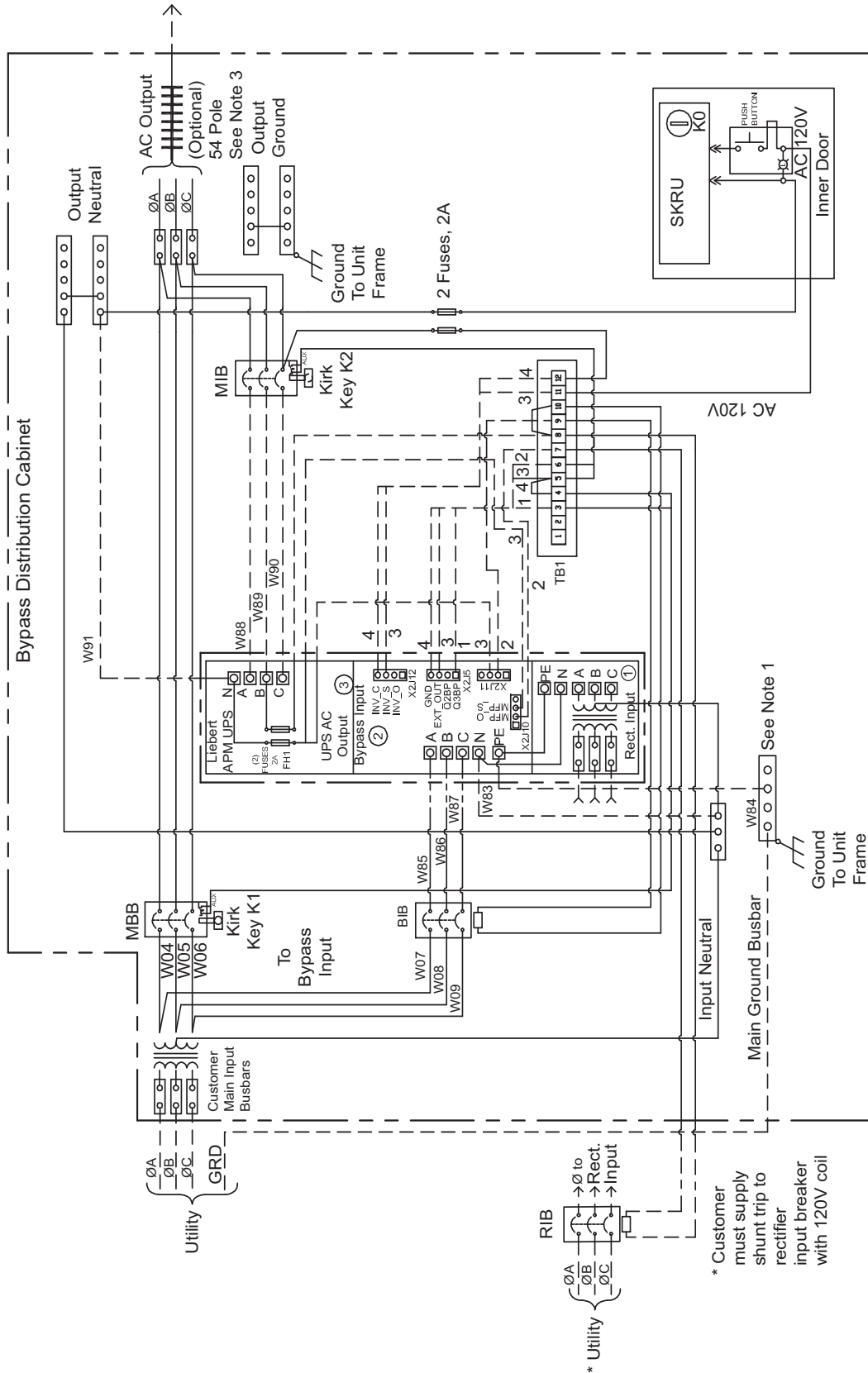

SKRU - SOLENOID
 KEY RELEASE UNIT
 KO - KEY OPERATOR
 --- Field-Supplied Wiring
 ——— Factory-Supplied Wiring

UAM04047
 Rev. 0

- NOTES**
1. Customer-furnished electrode conductor to be installed in accordance with national and local electrical codes.
 2. See installation manual for additional connection information.
 3. Optional 54 pole, 225A for 45kVA frame only or optional 54 pole 400A for 90kVA frame only.
 4. Transformer available: 208V, 220V, 480V and 600V input.
 5. Overcurrent protection is based on 80% rated devices.
 6. Ensure that the jumper bars between input and rectifier input are removed before starting the unit for the first time.
 7. See Drawing UAM02022.

The external maintenance bypass is available with a 480V, 600V or 208V optional internal transformer. Each UPS frame size (45kVA or 90 kVA) is available with a 480V, 600V or 208V optional internal transformer. Internal batteries are not available for a 45kVA frame that has an the internal transformer.

3.2.6 Cabling Guidelines

The following are guidelines only and are superseded by local regulations and codes of practice where applicable. Use wiring rated at 75°C or greater.

1. Take special care when determining the size of the neutral cable, as current circulating on the neutral cable may be greater than nominal current in the case of non-linear loads. Refer to the values in **11.4 - UPS Electrical Characteristics**.
2. The ground conductor should be sized according to such factors as the fault rating, cable lengths and type of protection. The ground cable connecting the UPS to the main ground system must follow the most direct route possible. Control wiring and power wiring must be run in separate conduit. Output and input cables must be run in separate conduit.
3. Consider using paralleled smaller cables for heavy currents—this can ease installation.
4. When sizing battery cables, a maximum voltage drop of 4VDC is permissible at the current ratings in **Table 43**. For terminal connection sizing, see **Tables 41 through 43**.
5. In most installations, the load equipment is connected to a distribution network of individually protected busbars fed by the UPS output, rather than connected directly to the UPS itself. When this is the case, the UPS output cables can be rated to suit the individual distribution network demands rather than being fully load-rated.



NOTE

If more load is added to the distribution panel, the unit's cabling must be resized.

6. When laying power cables, do not form coils; this will help avoid increasing formation of electromagnetic interference.



NOTE

Right-side access may be required when making power connections. Cable connections should be made before a cabinet is attached to the right side of the Liebert APM or before the UPS is placed where another obstruction, such as a wall, is against the Liebert APM's right side.

3.2.7 Cable Connections

The rectifier input, bypass output and battery are easily accessible from the right side of the unit for installation. All require lug type terminations. They are connected to busbars on the right side of the Liebert APM, as shown in **Figures 7 and 8**. These busbars are accessible when the right side panel is removed.

NOTICE

Risk of improper installation. Can cause equipment damage.

When wiring a single-input only system, connect only the power wiring to the input busbars.

Figure 7 Input busbars—Liebert APM 45kVA frame

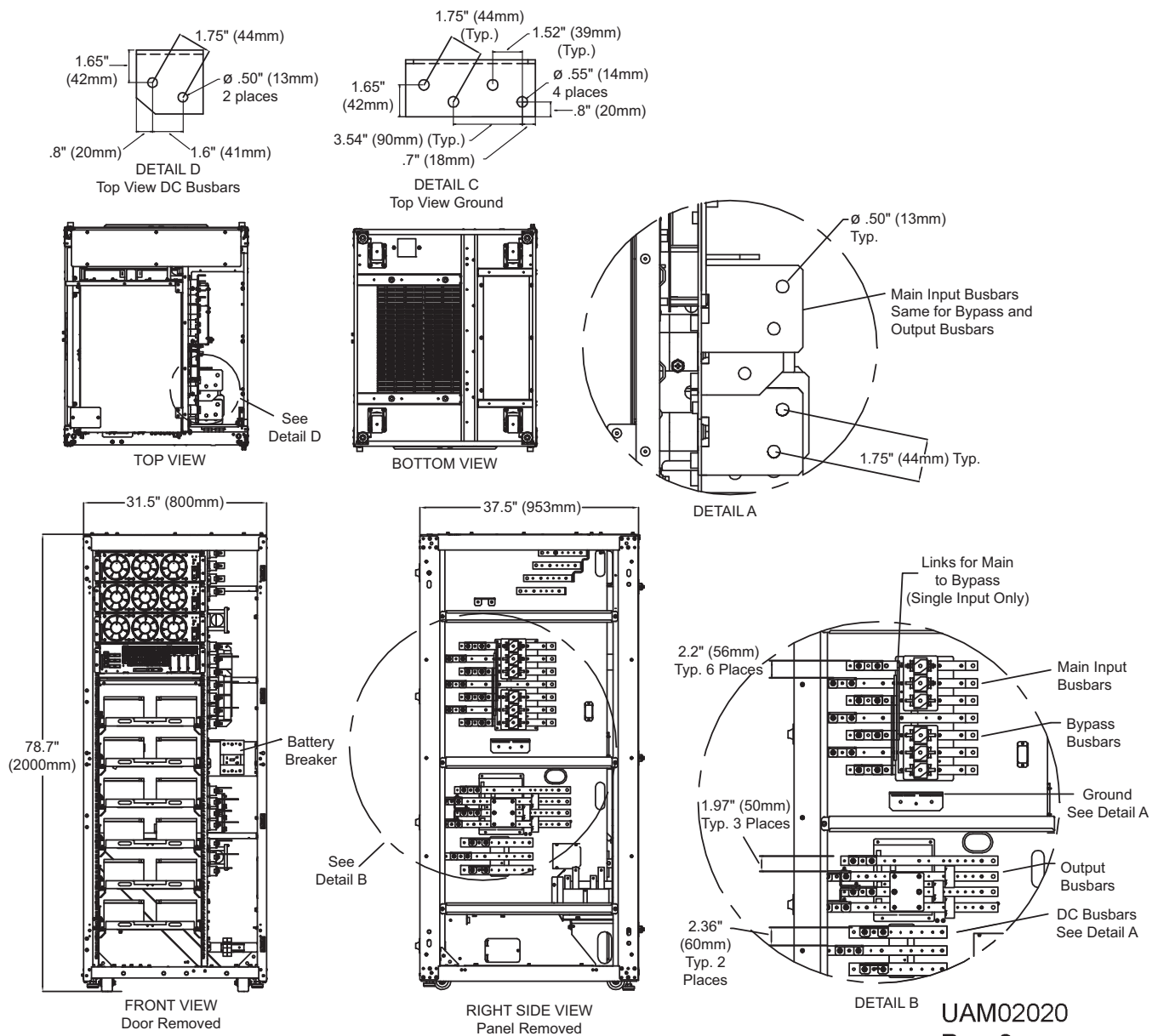

NOTES

1. All dimensions are in inches (mm).
2. Control wiring and power wiring must be run in separate conduits.
3. Copper cables only are recommended.
4. All wiring must be in accordance with national and local electrical codes.

Figure 8 Input busbars—Liebert APM 90kVA frame

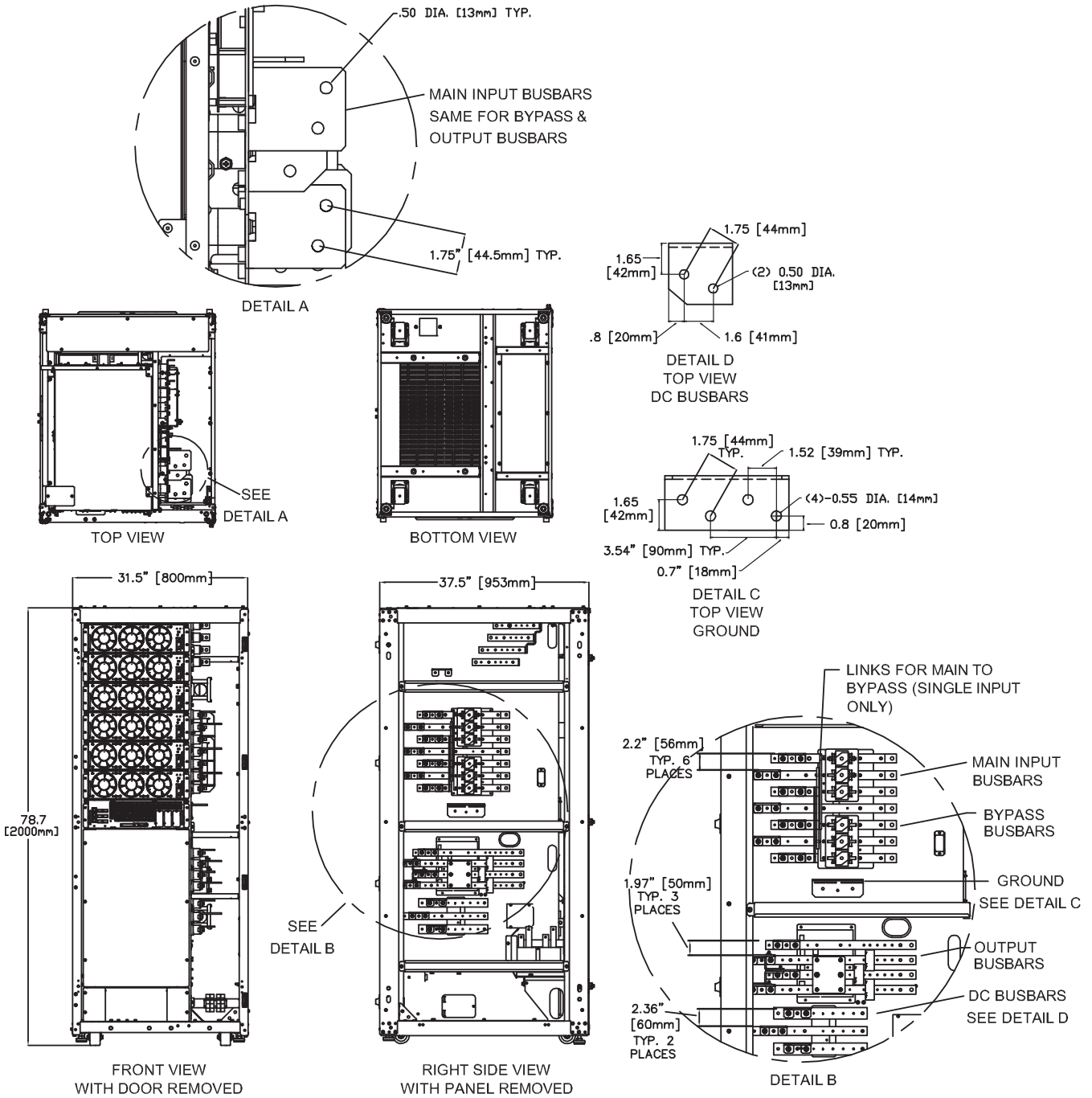

NOTES

1. Dimensions are in inches [mm].
2. Control wiring and power wiring must be in separate conduits.
3. Vertiv recommends using only copper cables.
4. All wiring must be in accordance with national and local electrical codes.

UAM0201
 Rev. 3

Figure 9 Liebert BDC

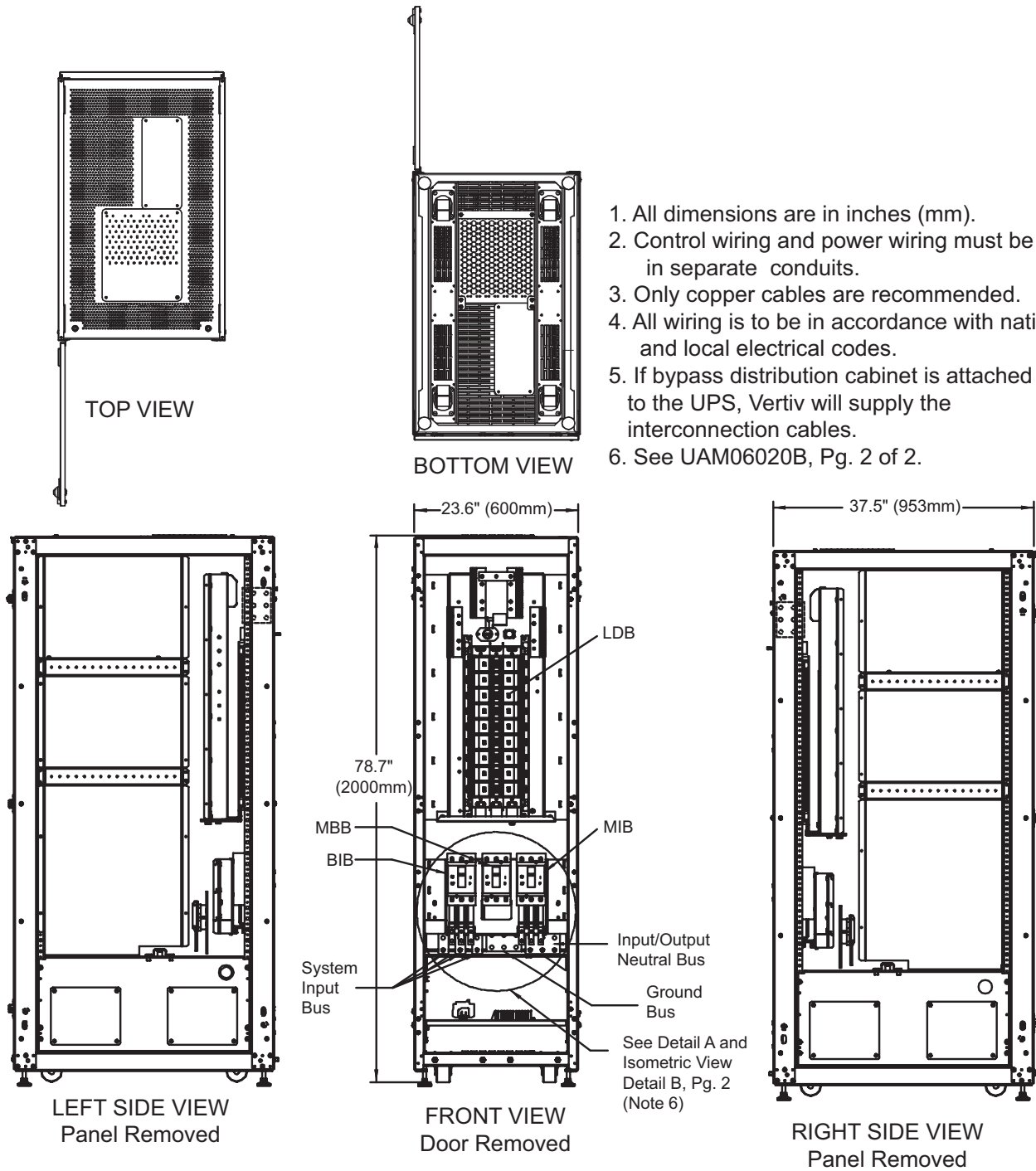

1. All dimensions are in inches (mm).
2. Control wiring and power wiring must be run in separate conduits.
3. Only copper cables are recommended.
4. All wiring is to be in accordance with national and local electrical codes.
5. If bypass distribution cabinet is attached to the UPS, Vertiv will supply the interconnection cables.
6. See UAM06020B, Pg. 2 of 2.

UAM06020A
Rev. 2

Figure 10 Busbars—Liebert BDC

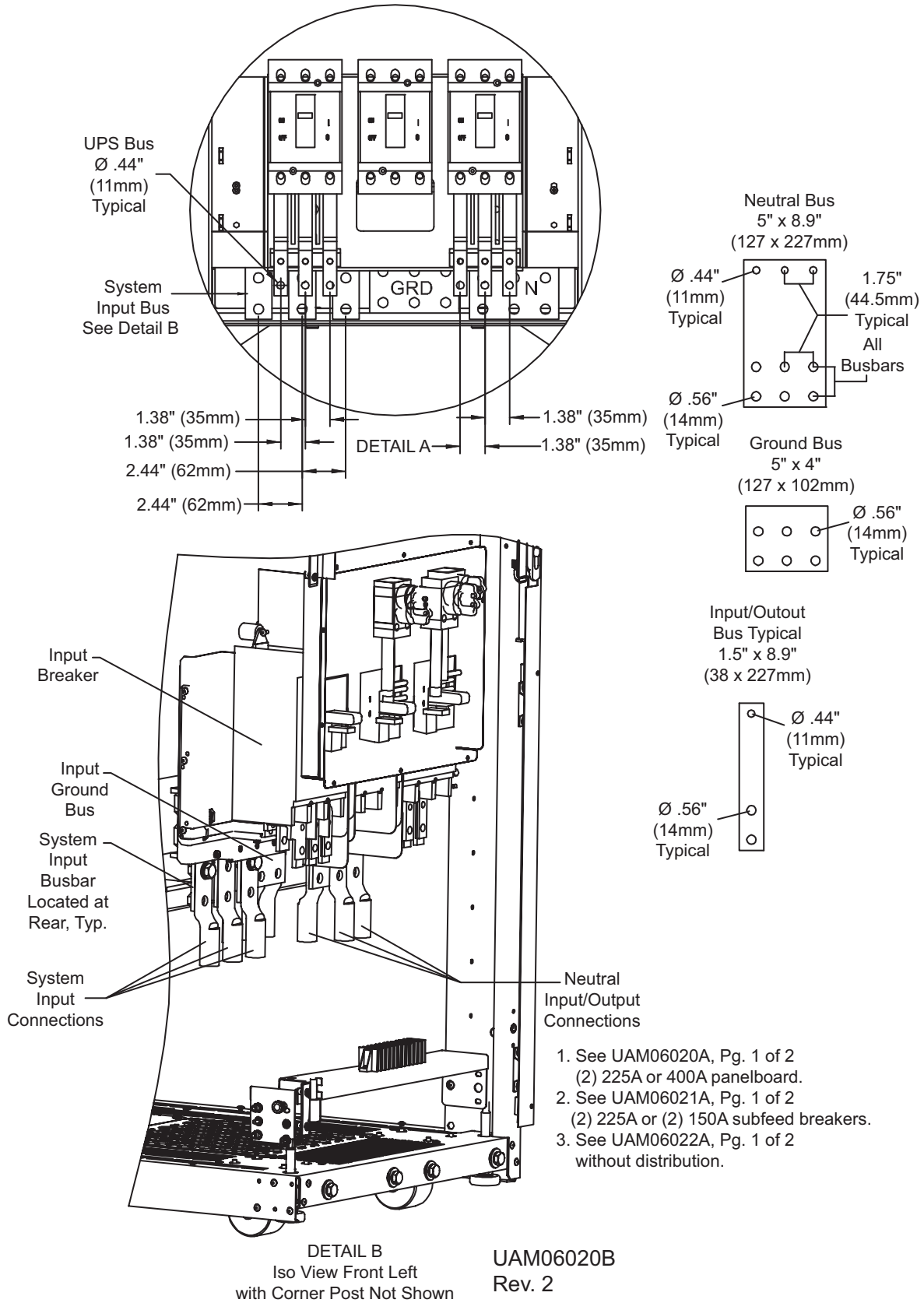

Figure 11 Busbars—External 600mm battery cabinet

TERMINAL SPECIFICATIONS

Unit Rating: 15-90kVA

Bolt Shaft Size: M10

Torque: 240 lb-in (27Nm)

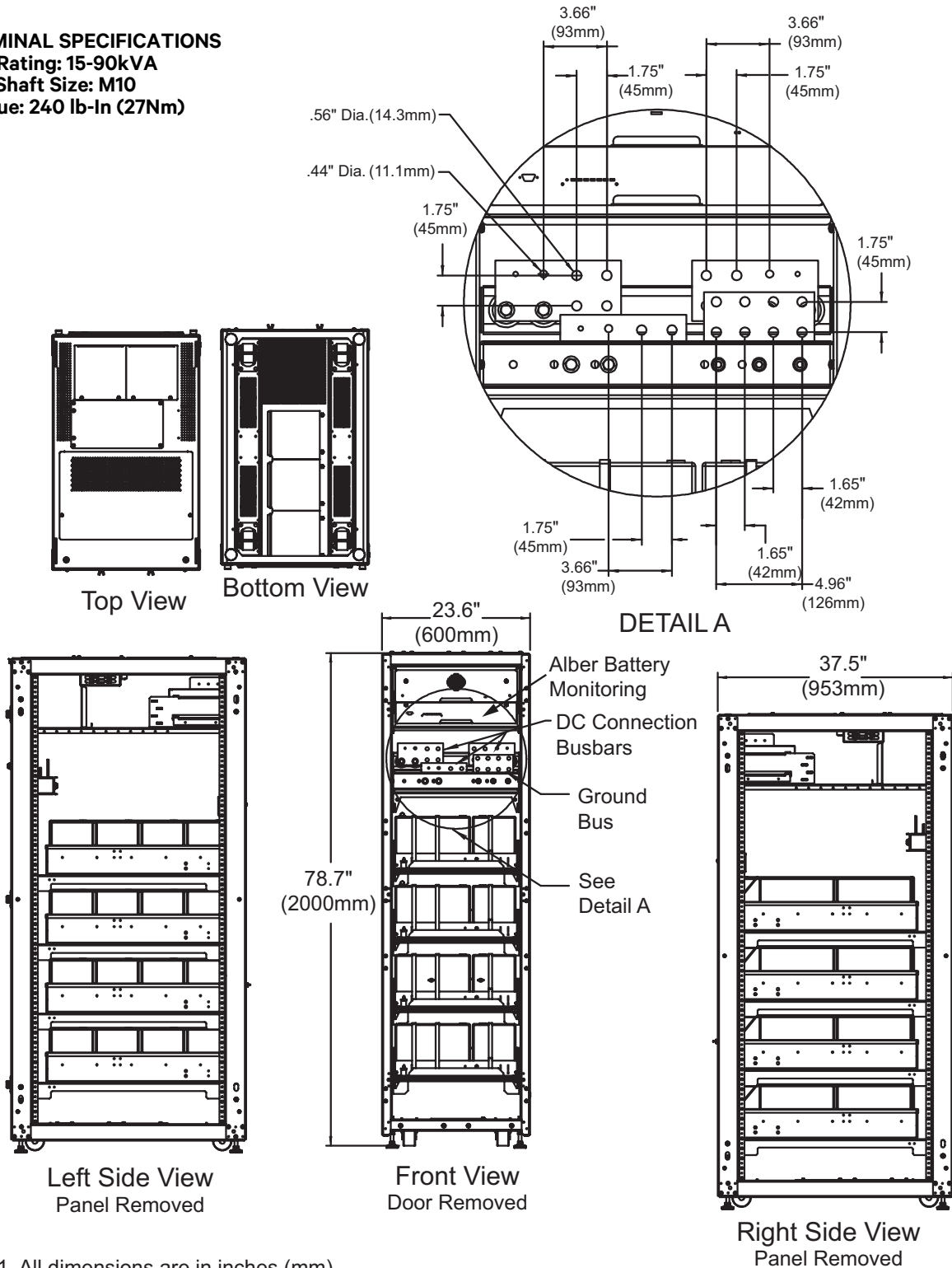

1. All dimensions are in inches (mm).
2. Control wiring and power wiring must be run in separate conduits.
3. Copper cables only are recommended.
4. All wiring is to be in accordance with national and local electrical codes.
5. If battery cabinet is attached to UPS, Vertiv will supply interconnect cables.

UAM05020
Rev. 1

Figure 12 Busbars—External 900mm battery cabinet

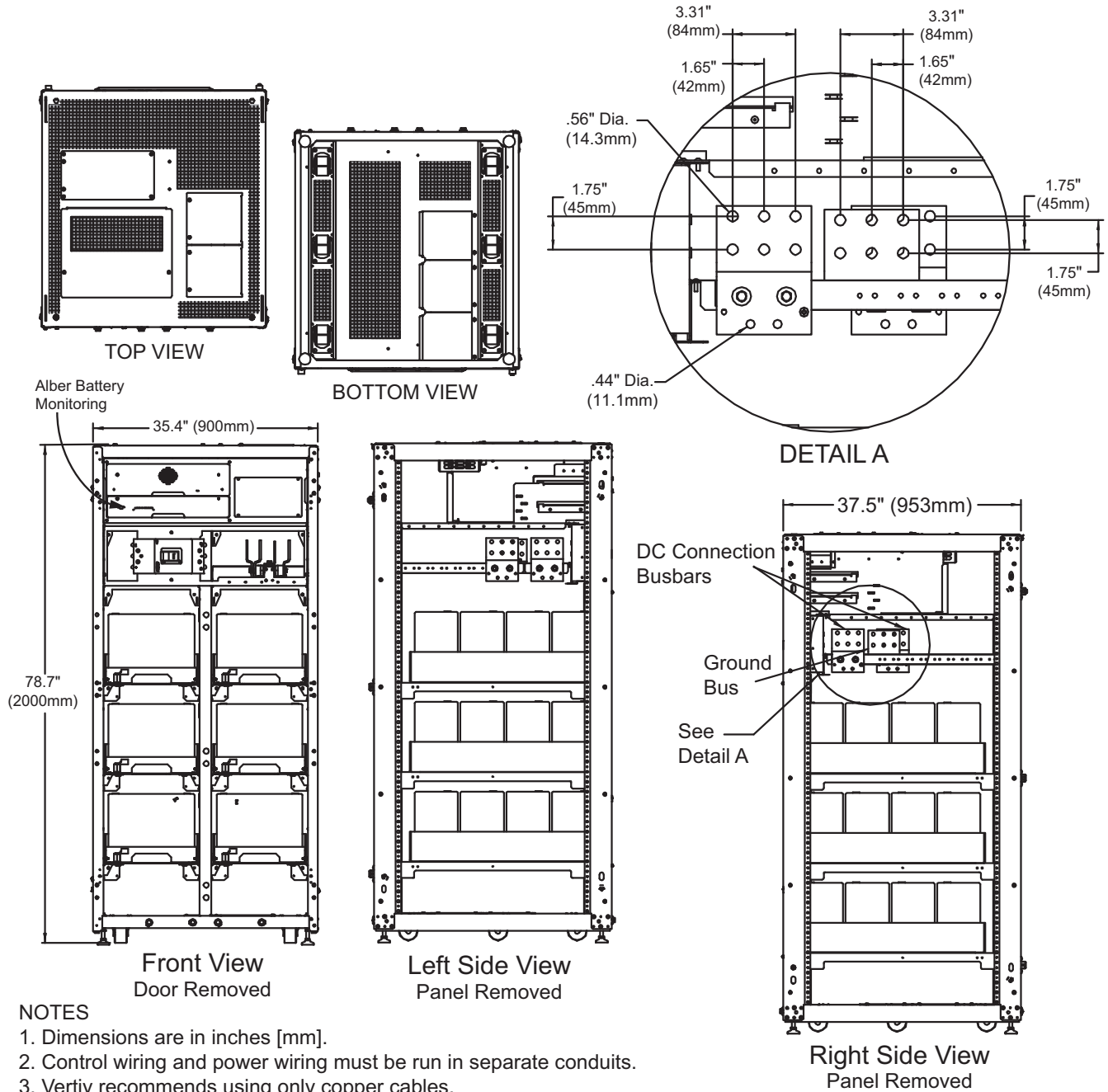

NOTES

1. Dimensions are in inches [mm].
2. Control wiring and power wiring must be run in separate conduits.
3. Vertiv recommends using only copper cables.
4. All wiring must be in accordance with national and local electrical codes.
5. If the battery cabinet is attached to the UPS, Vertiv will supply the interconnect cables.

UAM05022
Rev. 0

3.2.8 Accessory Fuses and Backfeed Breaker Wiring

Two fuse blocks provide power for the backfeed breakers (standard) and the BDSi (optional). The fuse blocks are at the lower right of the front of the Liebert APM UPS. Refer to **Figure 24** for additional details. See for fuse holder locations.

The backfeed breaker fuse block provides 120V nominal provided from the UPS output (L-N) and the fuse is rated for 8 amps. **Figure 14** shows the backfeed breaker wiring.

The BDSi fuse block provides 208V nominal from the UPS output (L-L) and the fuse is rated at 8A. The BDSi power wiring is shown in **Figures 40** and **65**.

Figure 13 Accessory fuses

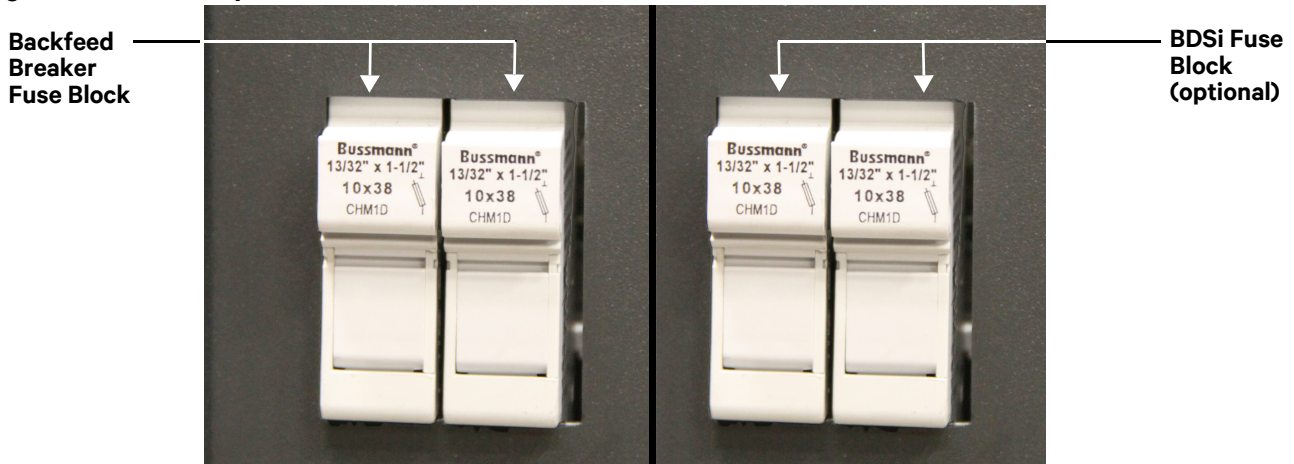
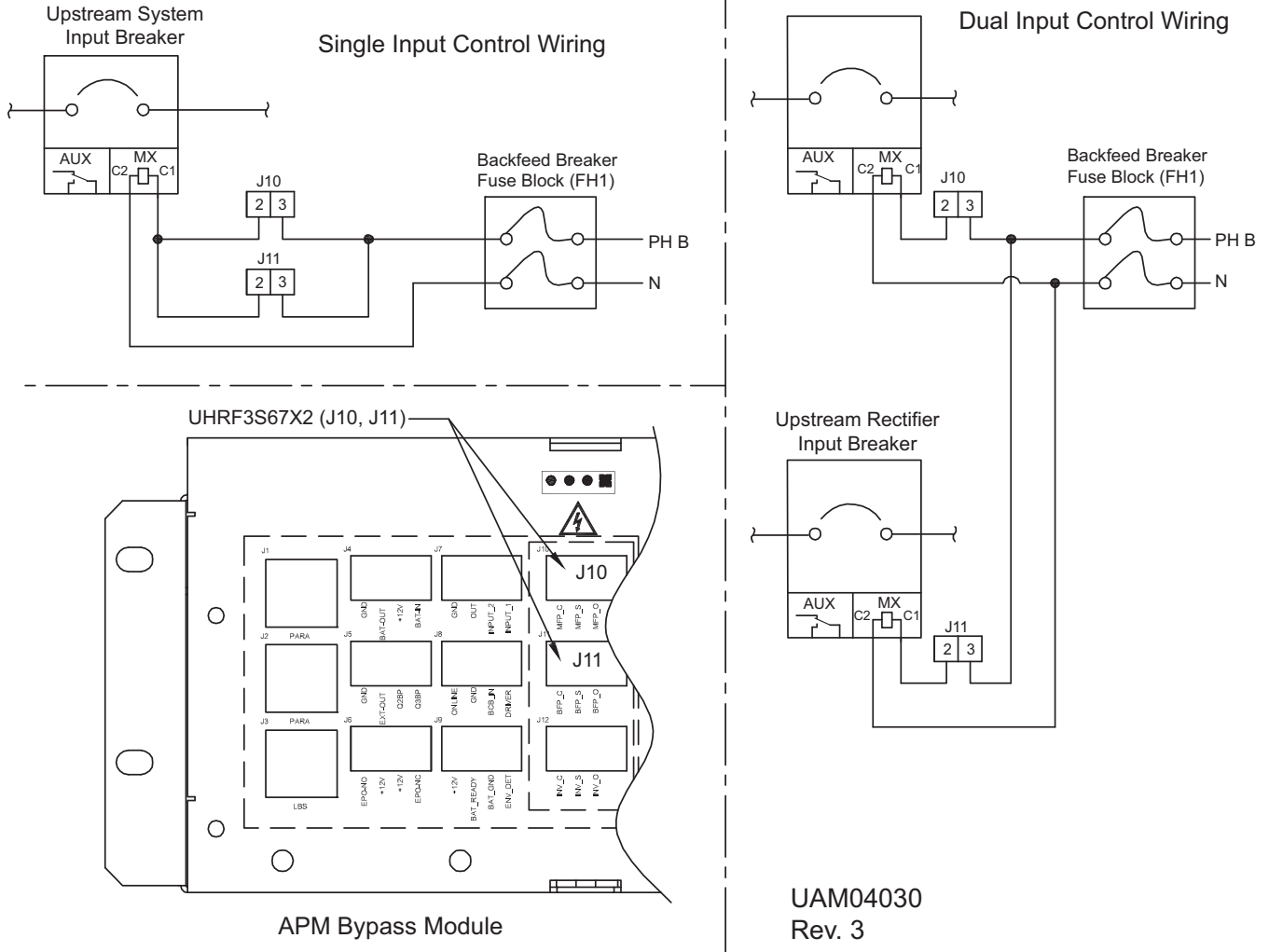

Figure 14 Dual input backfeed breaker wiring when bypass distribution cabinet not used

1. Auxiliary contacts not needed for backfeed breaker operation.
2. A 120V shunt trip coil is required for proper operation.



NOTE

Shunt trips are required in upstream breakers to allow backfeed protection to function properly.

3.2.9 Safety Ground

The safety ground busbar is below the neutral input and output busbars as shown in **Figure 15** below. The safety ground cable must be connected to the ground busbar and bonded to each cabinet in the system. This ground busbar is then connected to the ground electrode conductor (GEC).

All cabinets and cable conduit should be grounded in accordance with local regulations.



WARNING

Risk of electrical shock and arc flash. Can cause property damage, injury and death. Failure to follow proper grounding procedures can result in electric shock hazard to personnel or the risk of fire, should a ground fault occur.



NOTE

Proper grounding significantly reduces problems caused by electromagnetic interference.



NOTE

The ground and neutral busbars are easily accessible when the right side panel is removed. Cable connections should be made before a cabinet is attached to the right side of the Liebert APM or before the UPS is placed where another obstruction, such as a wall, is against the Liebert APM's the right side.

Figure 15 Ground and neutral busbar connections—45kVA frame busbars

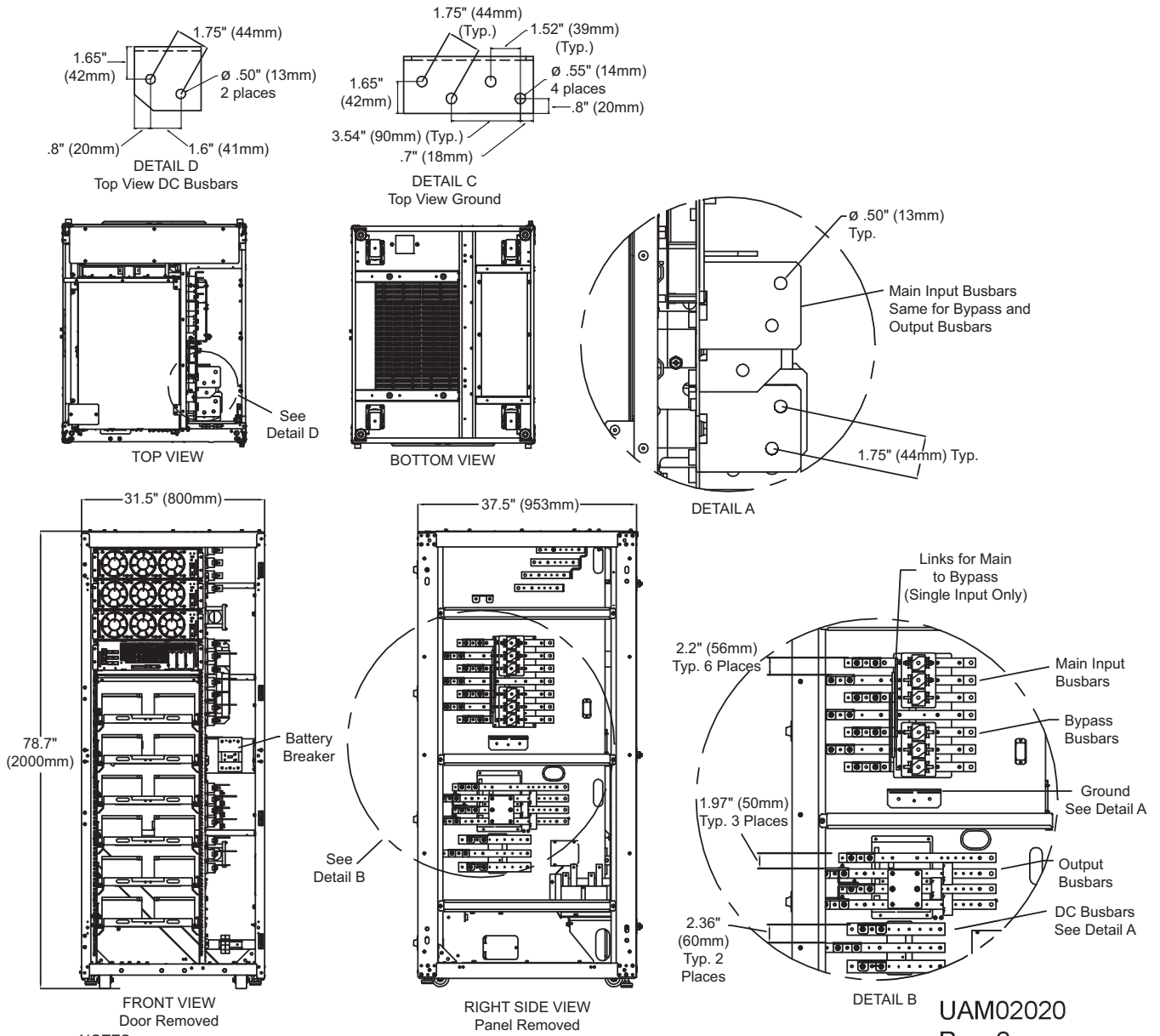

NOTES

1. All dimensions are in inches (mm).
2. Control wiring and power wiring must be run in separate conduits.
3. Copper cables only are recommended.
4. All wiring must be in accordance with national and local electrical codes.

**UAM02020
Rev. 2**

Figure 16 Ground and neutral busbar connections—90kVA frame busbars

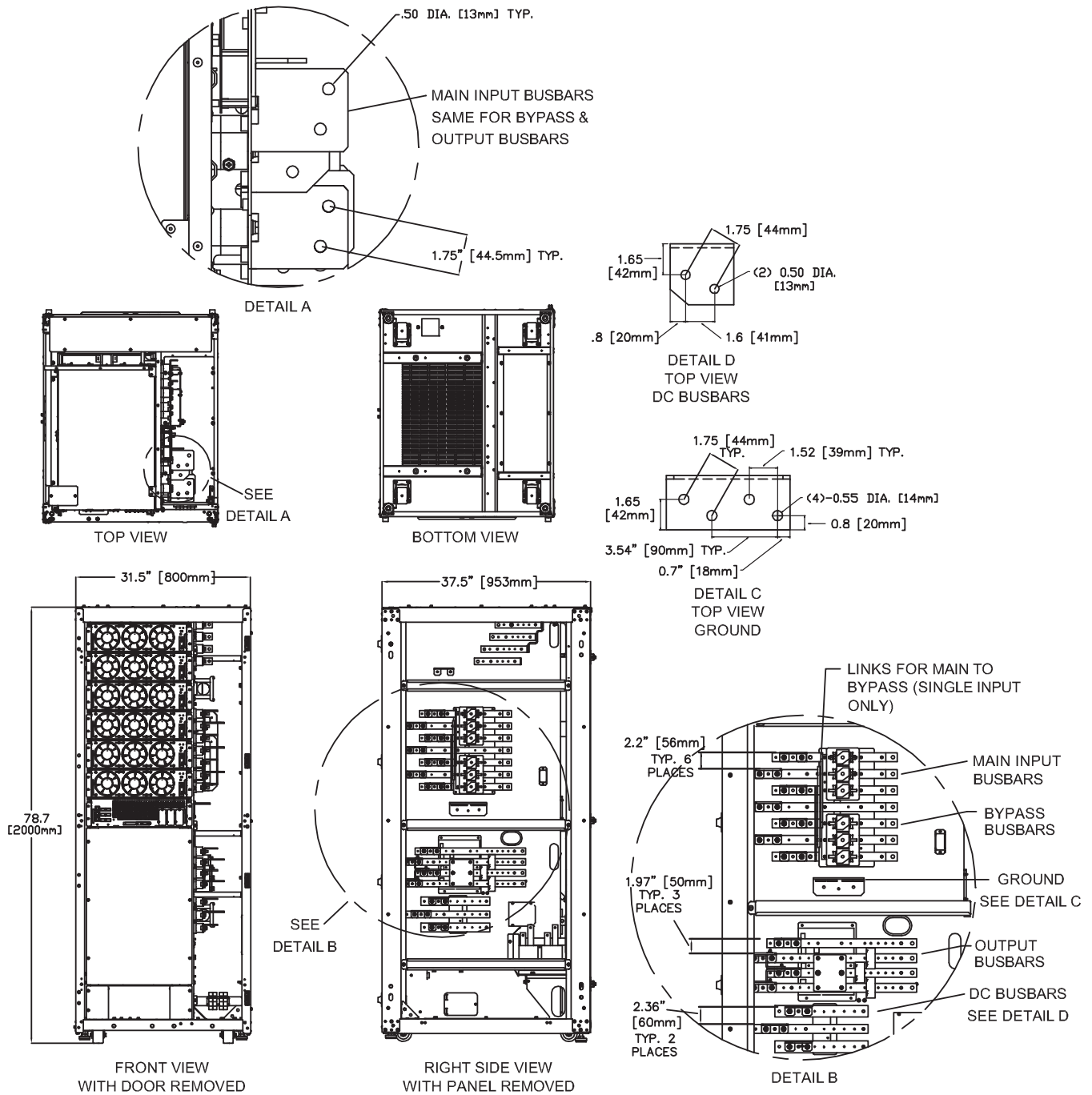

NOTES

1. Dimensions are in inches [mm].
2. Control wiring and power wiring must be run in separate conduits.
3. Vertiv recommends using only copper cables.
4. All wiring must be in accordance with national and local electrical codes.

UAM0201
Rev. 3

3.2.10 Protective Devices

For safety, it is necessary to install circuit breakers in the input AC supply external to the UPS system. Given that every installation has its own characteristics, this section provides guidelines

for qualified installation engineers with knowledge of operating practices, regulatory standards and the equipment to be installed.

UPS Rectifier and Bypass Input Supply

Protection from excessive overcurrents and short circuits in power supply input

External overcurrent protection for the AC output circuit is to be provided. See **11.4 - UPS Electrical Characteristics** and **Table 47** for overload capacity.

A breaker is used for internal battery circuit overcurrent protection. When an external battery supply is used, overcurrent protection for the battery circuit is to be provided by the customer.

- Dual Input Single Source

When wiring the UPS with dual inputs but with a single input source, the Rectifier input and the Bypass input must be protected separately. Size the breakers according to the input currents shown in **Table 41**.



NOTE

*For single or dual input, a 120V shunt trip coil(s) is required when a breaker is supplied by the customer. See **Figures 4 and 5** for details.*

Fuses

The Liebert APM's main input and bypass input busbars are equipped with fuses (six locations; see **Figure 51**). The type is Bussman 170M4465, rated at 550A and 700V.

System Output

When using an external distribution panel for load distribution, the output neutral and input neutral must be separated at the input to the UPS.

3.2.11 Cabling Procedure



CAUTION

The operations described in this section must be performed by authorized electricians or qualified technical personnel. If you have any difficulties, contact your local Vertiv representative or Vertiv.



NOTE

Hydraulic pressure pliers, combinative tools and piston ring pliers should be used to connect AC wiring.

Once the equipment has been positioned and secured for operation, and the battery and ground lugs have been connected (see **3.2.7 - Cable Connections**), connect the power cables as described below. (Study the reference drawing in **7.0 - Installation Drawings**.)

1. Verify that all incoming high and low voltage power circuits are de-energized and locked out or tagged out before installing cables or making any electrical connections.
2. Remove the right side panel to gain easier access to the connections busbars.
3. Connect the safety ground and any easier bonding ground bus cables to the copper ground busbar located in the middle of the Liebert APM below the Input and Bypass connections. All cabinets in the UPS system must be connected to the user's ground connection.



NOTE

The grounding and neutral bonding arrangement must comply with the National Electrical Code and all applicable local codes.

4. Identify and make power connections with incoming cables according to **Steps 5 through 8**.

Common Input Connections

5. For common bypass and main inputs, connect the AC input supply cables to the UPS input terminals (A2-B2-C2-N1) and tighten the connections to 240lb-in. (27N-m) (M10 Bolt). Ensure correct phase rotation.



NOTE

For common bypass and main inputs, the AC input cables must be connected to the bypass terminal (A2-B2-C2-N1) but not the main input terminal (A2-B2-C2).

Split Bypass Connections

6. If a split bypass configuration is used, connect the AC input supply cables to the rectifier input terminals (A1-B1-C1-N1) and the AC bypass supply cables to the bypass input terminals (A2-B2-C2-N1) and tighten the connections to 240lb-in. (27N-m) (M10 Bolt). Ensure correct phase rotation.



NOTE

For split bypass operation, ensure that the busbars between bypass and rectifier inputs are removed. The neutral line of the bypass input must be connected to that of the rectifier input.

Output System Connections—Ensure Correct Phase Rotation

7. Connect the system output cables between the UPS output busbars (A-B-C-N terminals) and the critical load and tighten the connections to 240lb-in. (27N-m) (M10 bolt).



WARNING

Risk of electrical shock and arc flash. Can cause property damage, injury and death. If the load equipment will not be ready to accept power when the commissioning engineer arrives, ensure that the system output cables are safely isolated.

Internal UPS Battery Connections

The UPS internal batteries will be connected at the factory, EXCEPT the connections between the shelves and to the breaker.



WARNING

Risk of electrical shock and arc flash. Can cause property damage, injury and death. The DC bus is live when this internal battery connection is made. This connection is to be performed ONLY by Vertiv at startup.

Observe the battery cable polarity. Be sure that the battery connection is made with the correct polarity.

8. Refit all protective covers removed for cable installation.

3.3 Control Cables Details

3.3.1 Static Bypass Assembly Features

Based on your site's specific needs, the UPS may require auxiliary connections to manage the battery system (external battery circuit breaker, battery temperature sensor), communicate with a personal computer or provide alarm signaling to external devices or for Remote

Emergency Power Off (REPO). Terminations for these functions are located at the front of the static bypass module. The main features are:

- Input and output dry contacts signal (one pair of contacts of relay)
- Emergency Power Off control (EPO)
- Environmental parameter input interface
- User communication (for data setting and user background monitor)
- Liebert IntelliSlot[®] interface
- Temperature detect interface

Figure 17 Static bypass assembly connections to display cabinet and options

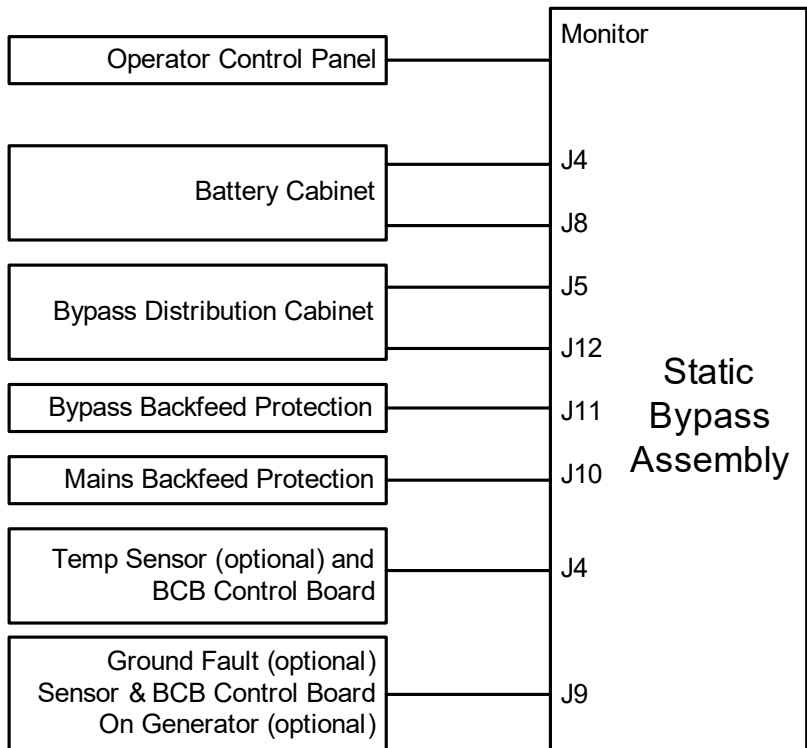
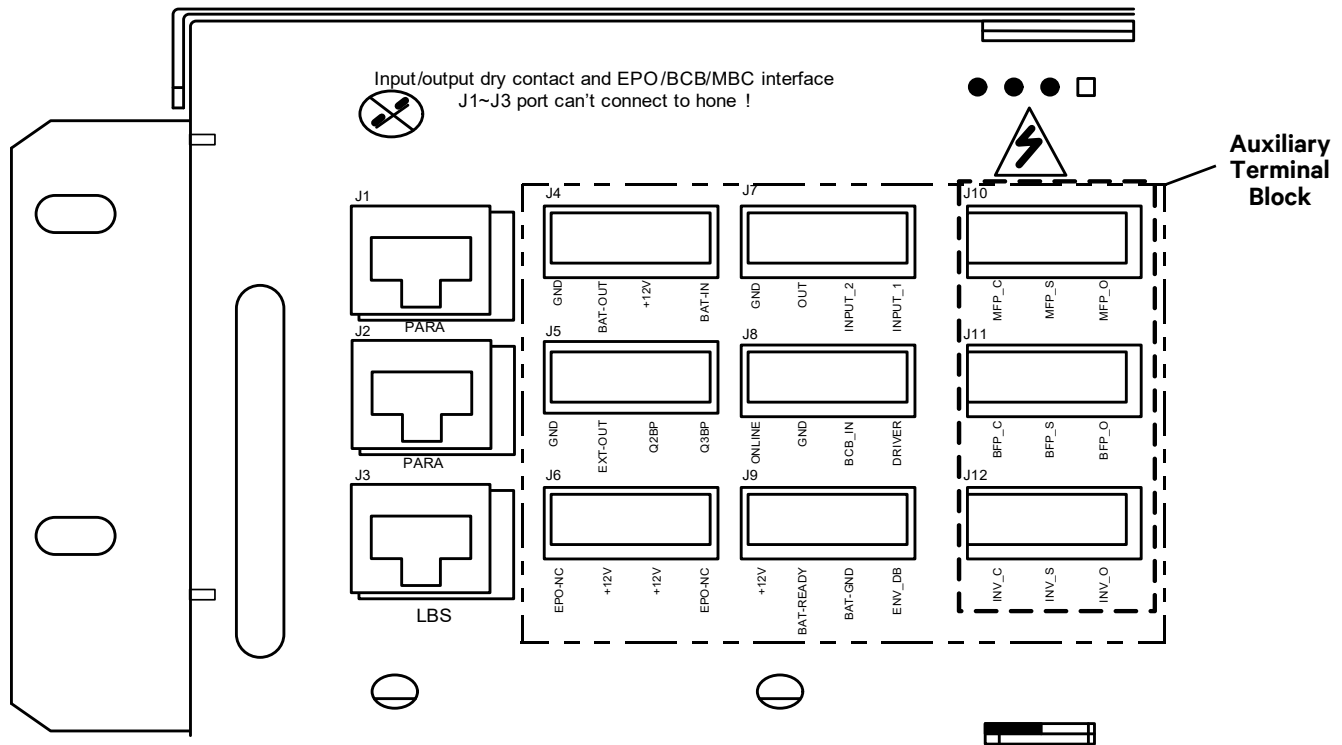

Figure 18 Auxiliary terminal block detail (static switch assembly front panel)



NOTE

Terminal block connectors are on the left side of the static bypass assembly.

3.4 Dry Contacts

The UPS provides input dry contacts and output dry contacts on the Auxiliary Terminal Block (ATB).

3.4.1 Input Dry Contacts

External input dry contacts are connected via the ATB. Dry contacts are available for environment detection, battery ground fault detection, etc.

The UPS accepts external signal from zero-voltage (dry) contacts connected through external dry contact terminals produced, and these terminals are on the static bypass assembly. Through software programming, these signals become active when these contacts connect to +12V to ground (in the most left side). The cables connected to the monitor board must be separated from power cables. Moreover, these cables should be double-insulated with a typical cross-section of 0.5 to 1mm² for a maximum connection length between 82 and 165ft. (25-50m). The ATB has several input dry contacts.

Figure 19 Input dry contacts

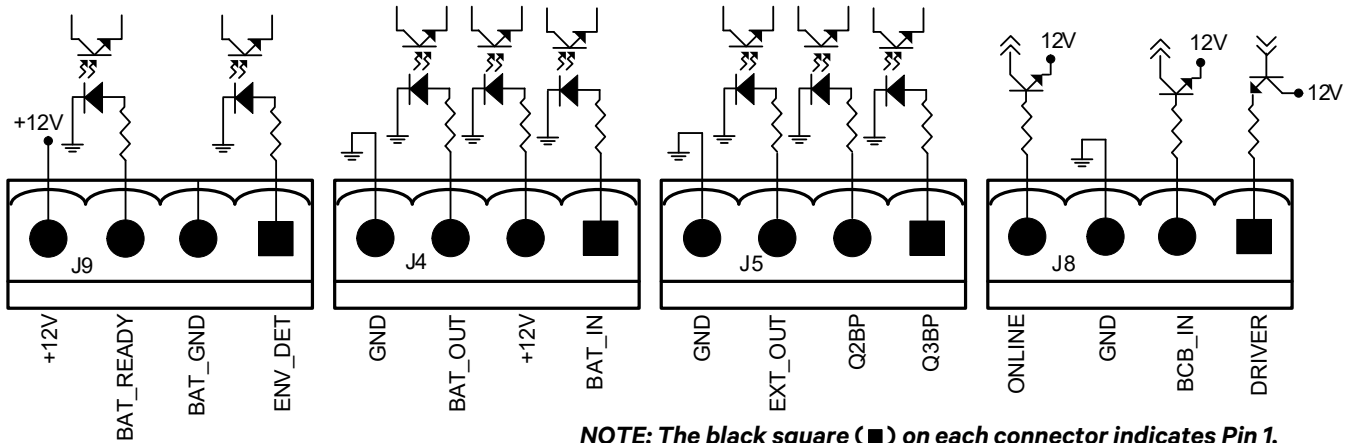

NOTE: The black square (■) on each connector indicates Pin 1. Refer to Figure 18 for the location of connectors J4, J5, J8 and J9.

Table 4 Description of dry contact input port

Position	Name	Description
J9.1	ENV_DET	Detection of battery room environment (normally closed); On Generator; EVN
J9.2	BAT_GND	Battery short to ground detection; BtG; On Generator
J9.3	BAT_READY	Not Used
J9.4	+12V	+12V power supply
J4.1	BAT_IN	Internal battery temperature detection
J4.2	+12V	+12V power supply
J4.3	BAT_OUT	External battery temperature detection
J4.4	GND	Power supply GND
J5.1	Q3BP	Input circuit breaker status of external Liebert BDC
J5.2	Q2BP	Output circuit breaker status of external Liebert BDC
J5.3	EXT_OUT	Input circuit breaker status of internal Liebert BDC
J5.4	GND	Power supply GND
J8.1	DRIVER	BCB Driver Signal
J8.2	BCB_IN	BCB Contact State
J8.3	GND	Power Ground
J8.4	ONLINE	BCB On-Line - Input (N.O.) - This pin will become active when the BCB interface is connected.

3.4.2 Output Dry Contacts

The Auxiliary Terminal Block has three output dry contact relays (see **Figure 20** and **Table 5**).

Figure 20 Output dry contacts and EPO wiring

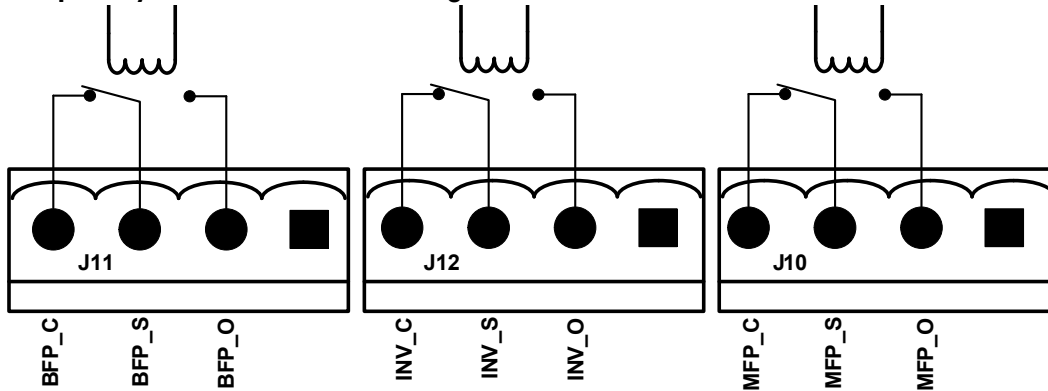

NOTE: The black square (■) on each connector indicates Pin 1. Refer to Figure 18 for the location of connectors J10, J11 and J12.

Table 5 Output dry contact relays

Position	Name	Description
J11.2	BFP_O	Bypass feedback protection relay. Normally open. Closed when bypass SCR is shorted.
J11.3	BFP_S	Bypass feedback protection relay center
J11.4	BFP_C	Bypass feedback protection relay. Normally closed. Open when bypass SCR is shorted.
J12.2	INV_O	Inverter mode relay. Normally open. Closed when UPS is in inverter mode.
J12.3	INV_S	Inverter mode relay common
J12.4	INV_C	Inverter mode relay. Normally closed. Open when UPS is in inverter mode.
J10.2	MFP_O	Main feedback protection relay. Normally open. Closed when bypass SCR is shorted.
J10.3	MFP_S	Main feedback protection relay common
J10.4	MFP_C	Main feedback protection relay. Normally closed. Open when bypass SCR is shorted.



NOTE

All auxiliary cables of terminal must be double-insulated. Wire should be 20-16AWG stranded for maximum runs between 80 and 200 feet (25-60m), respectively.

3.4.3 Liebert BDC Interface

The Liebert BDC interface is on the Auxiliary Terminal Block at J5. Refer to **Figure 18** for the location of connector J5 and to **Figure 19** for circuit details.

Table 6 Liebert BDC interface

Position	Name	Description
J5.1	Q3BP	Input circuit breaker status of external Liebert BDC
J5.2	Q2BP	Output circuit breaker status of external Liebert BDC
J5.3	EXT_OUT	Input circuit breaker status of internal Liebert BDC
J5.4	GND	Power supply GND

These contacts cannot be active unless they are set via software.



NOTE

All auxiliary cables of terminal must be double-insulated. Wire should be 20-16AWG stranded for maximum runs between 80 and 200 feet (25-60m), respectively.



NOTE

*Refer to **Table 10** and **Figure 45** for the Liebert BDC wiring.*

3.4.4 Battery Cabinet Interface Connectors

The battery cabinet interface is on the Auxiliary Terminal Block at J8 and J4. Refer to **Figure 18** for the location of connectors J4 and J8 and to **Figure 19** for circuit details.

Table 7 Battery cabinet interface

Position	Name	Description
J4.1	BAT_IN	Internal Battery Temperature Detection
J4.2	+12V	+12V Power Supply
J4.3	BAT_OUT	External Battery Temperature Detection
J4.4	GND	Power Ground
J8.1	DRIVER	BCB Driver Signal
J8.2	BCB_IN	BCB Contact State
J8.3	GND	Power Ground
J8.4	ONLINE	BCB On-Line - Input (N.O.) - This pin will become active when the BCB interface is connected.



NOTE

All auxiliary cables of terminal must be double-insulated. Wire should be 20-16AWG stranded for maximum runs between 80 and 200 feet (25-60m), respectively.



NOTE

*Refer to **Table 9** and **Figure 40** for battery cabinet wiring.*

3.4.5 EPO Input—Optional

NOTICE

Risk of exceeding internal voltage limits. Can cause equipment damage.

Do not apply more than 12V to the Emergency Power Off (EPO) input. Exceeding 12V on this input can damage the Liebert APM's internal circuitry and control boards. Exceeding 12V will also put the Liebert APM in an EPO state, and the unit will not reset, making it non-functional.

The UPS has an Emergency Power Off (EPO) function operated by a button on the control panel or by a remote contact provided by the user. The EPO button is under a hinged, clear plastic shield.

The J6 connector, shown in **Figure 21**, is the remote EPO input interface. The EPO has NO/NC contacts that become active when shorting terminals J6: 3 and 4 or open terminal connection J6: 2 and 1.

If an external Emergency Stop capability is required, it is connected at terminals J6: 1 and 2 and at J6: 3 and 4 on the monitor board. It also is connected to the Normally Open or Normally Closed remote stop switch between these two terminals using shielded cable (see **Figure 21** and **Table 8**). If this function is not used, terminals J6:3 and 4 must be opened and J6:1 and 2 must be closed.

Figure 21 EPO wiring and signal names for J6

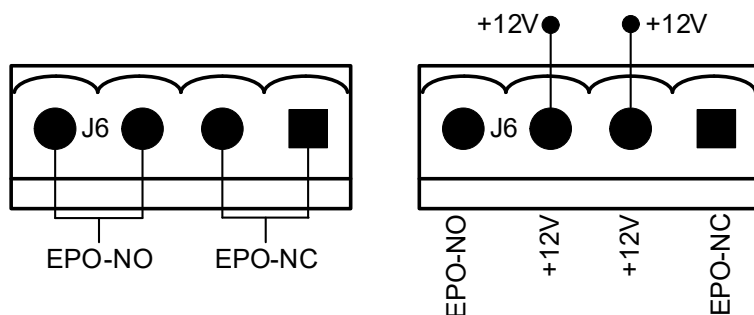

NOTE: The black square (■) on each connector indicates Pin 1. Refer to Figure 18 for the location of

Table 8 EPO input contact relays

Position	Name	Description
J6.1	EPO_NC	EPO Activated when opened to J6.2
J6.2	+12V	EPO Activated when opened to J6.1
J6.3	+12V	EPO Activated when shorted to J6.4
J6.4	EPO_NO	EPO Activated when shorted to J6.3



NOTE

The Emergency Stop action within the UPS shuts down the rectifier, inverter and static bypass. It does not internally disconnect the input power supply. To disconnect ALL power to the UPS, open the upstream feeder breaker(s) when the remote EPO is activated.



NOTE

Normally Closed EPO – J6: 1, 2, these terminals are supplied factory-linked on the Bypass Module on the UPS and must remain installed if using NO contacts.



NOTE

All auxiliary cables of terminal must be double-insulated. Wire should be 20-16AWG stranded for maximum runs between 80 and 200 feet (25-60m), respectively.

Figure 22 Single UPS Remote Emergency Power Off

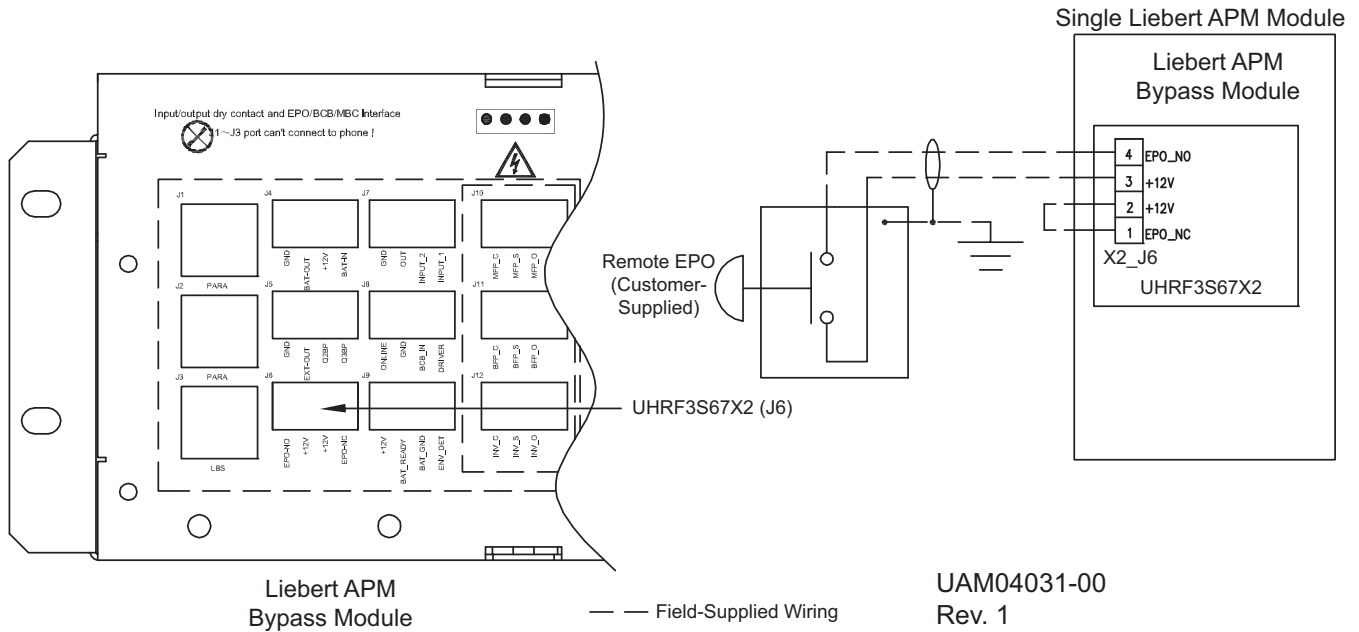

4.0 PARALLEL SYSTEM AND LBS SYSTEM INSTALLATION

This chapter gives details on the installation of a parallel system and an LBS system.

4.1 General

A parallel Liebert APM system can consist of two Liebert APM cabinets connected in parallel without a main system static bypass. Instead, the bypass static switches of each UPS share the load when the system transfers to the utility bypass supply. A third-party APM paralleling switchboard may be used to provide external maintenance capability. See **Figure 23** for details.

From a power viewpoint, each module is internally identical to the single-module configuration. A parallel system requires intermodule control signals to manage the load sharing, synchronizing and bypass switching. The control signals are connected through parallel communication cables, which provide bi-directional communication between the two Liebert APM units of the system. A second parallel cable is provided to establish redundancy.

When Liebert APM units are to be connected in parallel, a sharing inductor assembly is required and must be installed inside the Liebert APM cabinet. The inductor may be installed at the factory or field-installed.

4.2 System Installation Procedures

The installation of a parallel UPS should follow the procedures for a single UPS module with the additional requirements detailed in this section.

4.2.1 Preliminary Checks

Be sure that the options of the parallel cables are correct and that the modules are of the same rating, model and with the same software and hardware release.



WARNING

To achieve coordinated operation of the modules in the parallel system, it is required to configure each module separately using Vertiv configuration software. This must be done by Vertiv service personnel.

4.2.2 Cabinet Installation

Position the UPS modules and make connections as shown in **Figure 23**. The output distribution consisting of external UPS output switches and maintenance bypass must be installed, as shown in **Figure 23**, to facilitate maintenance and system testing.

Figure 23 UPS system with external maintenance switch

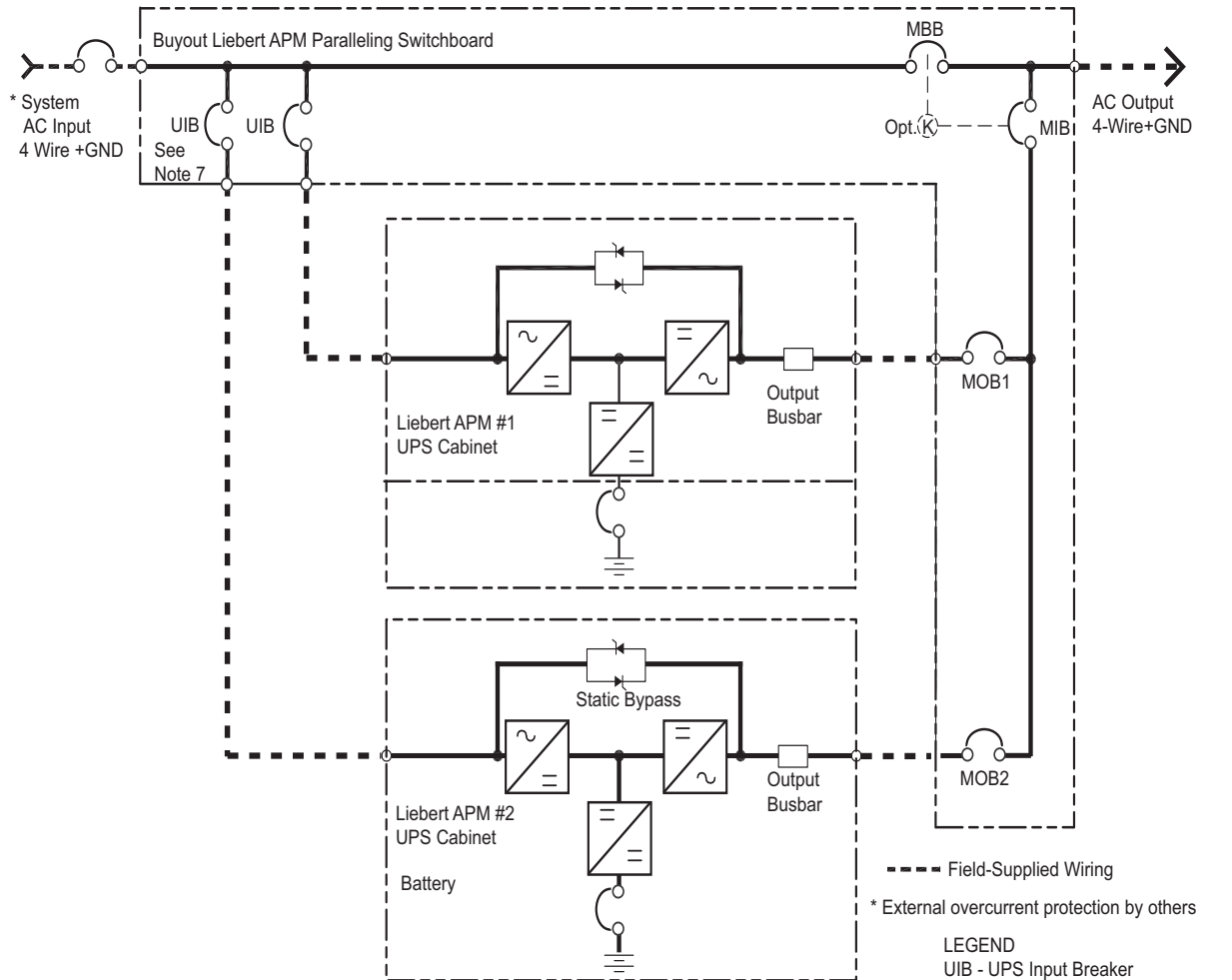

NOTES:

1. Install in accordance with national and local electrical codes.
2. Input and bypass must share the same single source.
3. A neutral is required from the system AC input source. A full capacity neutral conductor is recommended. Grounding conductors are recommended.
4. Bypass and rectifier inputs and output cables must be run in separate conduits.
5. Control wiring must be run in separate conduits.
6. The 90kVA frame has a capacity of up to six Flex Power assemblies and the 45kVA frame has a capacity of up to three Flex Power assemblies.
7. Paralleling switchboard requires shunt trip UIB breakers with 120V coils.
8. See drawings UAM01080B, UAM01080C, UAM01080D, UAM01080E and UAM01080F. Refer to the following battery cabinet control wiring drawings:
UAM04000
UAM4001A,B
UAM4002A,B D)

LEGEND
 UIB - UPS Input Breaker
 MOB - Module Output Breaker
 MIB - Maintenance Isolation Breaker
 MBB - Maintenance Bypass Breaker

UAM01060A
 Rev. 0



NOTE

For parallel system installations, an external bypass rated for the total system load must be installed.

For parallel systems, Vertiv recommends installing bypass load sharing inductors to optimize current sharing during static bypass operation.

4.2.3 External Protective Device

Refer to **3.2 - External Protective Devices**.

4.2.4 Power Cable

The power cable wiring is similar to that of the UPS module. Refer to **3.1 - Power Cabling**.

The bypass and rectifier input supplies must use the same neutral line input terminal. If the input has a current leakage protective device, the current leakage protective device must be fitted upstream of the neutral line input terminal.



NOTE

The length and specification of power cables including the bypass input cables and UPS output cables should be the same. This facilitates load sharing in bypass mode.

4.2.5 Input Breaker Control Wiring

Figure 24 Input breaker control wiring for parallel systems

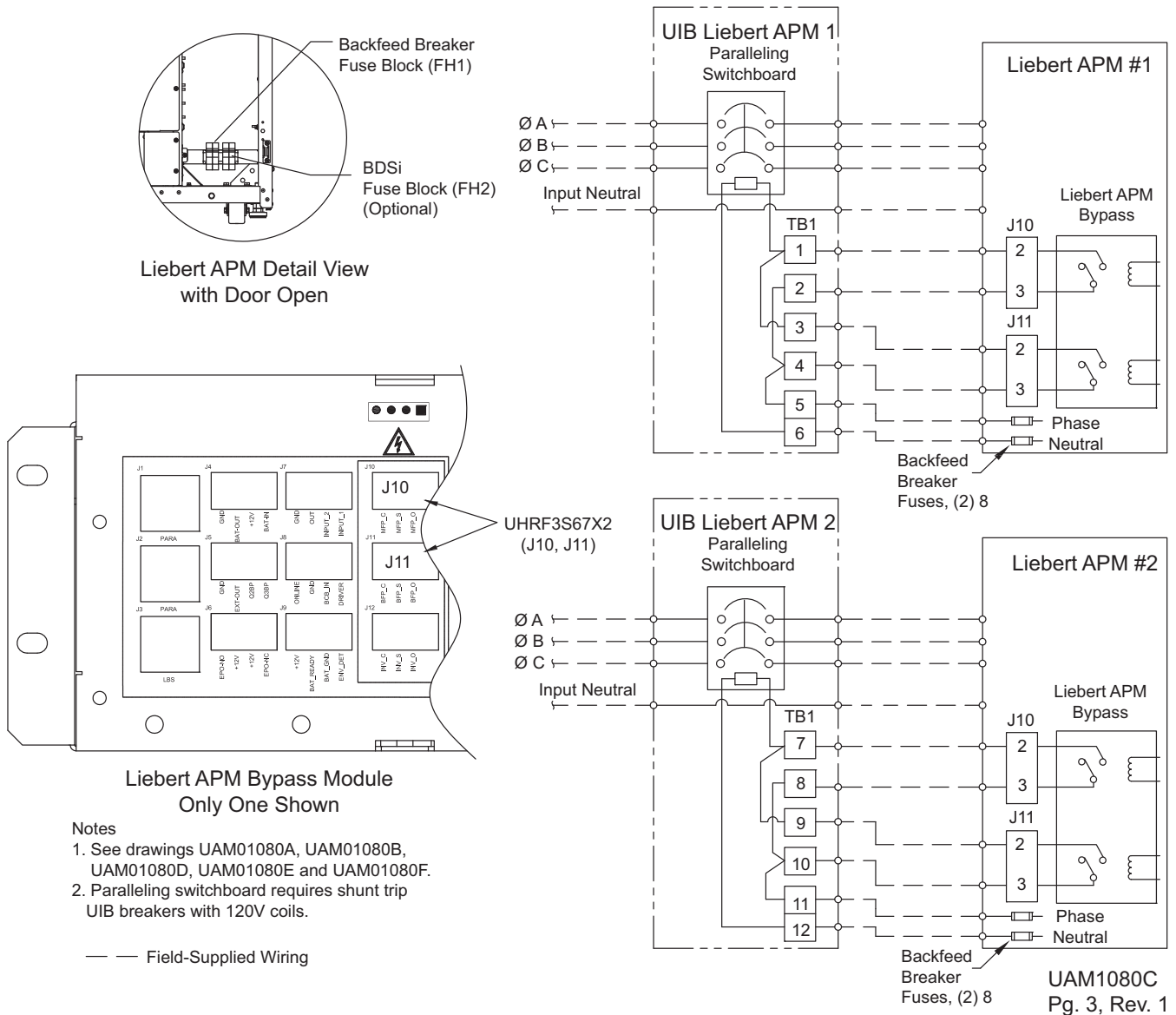

4.2.6 Output Breaker Control Wiring

Auxiliary wiring must be installed as shown in **Figure 25** to protect the system and enable a single UPS to be isolated and tested during service.

Figure 25 Output breaker control wiring

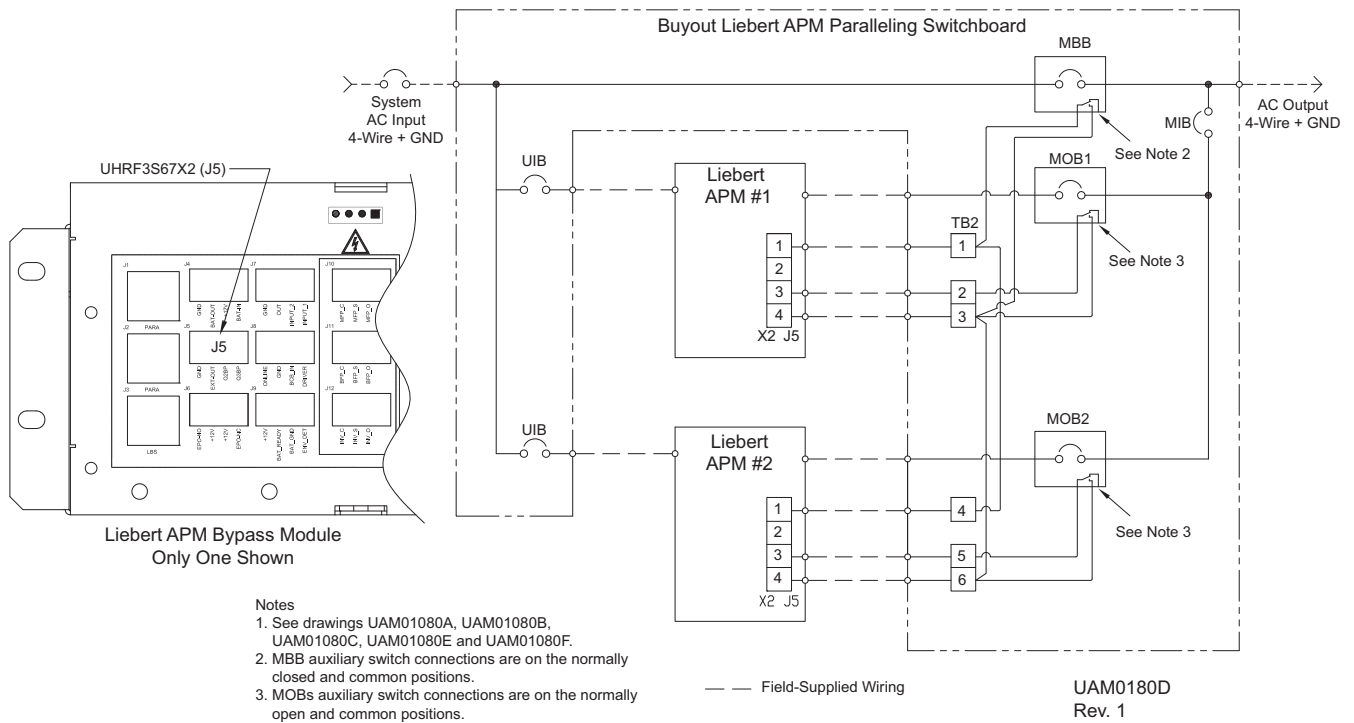

4.2.7 Parallel Cables

Shielded and double-insulated parallel control cables available in lengths of 16.4ft. and 32.8ft. (5m and 10m) must be interconnected in a ring configuration between the UPS modules, as shown in **Figure 26**. The parallel ports J1 and J2 are provided on the front panel of the bypass module, as shown in **Figure 28**. The ring connection ensures the reliability of the control of the parallel system. Be sure to verify the reliable cable connection before starting up the system!



NOTE

Use the shortest parallel control cables possible for the application. Do not coil excess cable. Meanwhile, separate the parallel control cables from the power cables to prevent electrical interferences.

Figure 26 Connection of parallel control cables of parallel system

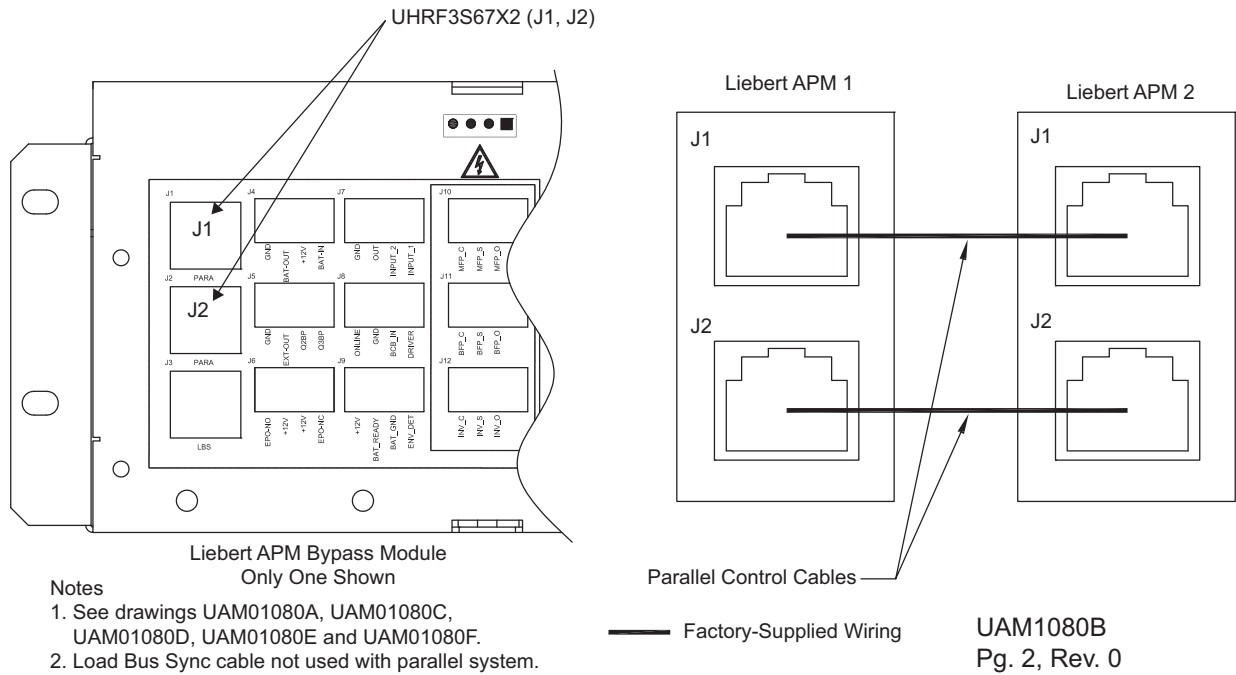

4.2.8 Key Interlock System

Figure 27 Key interlock system control wiring

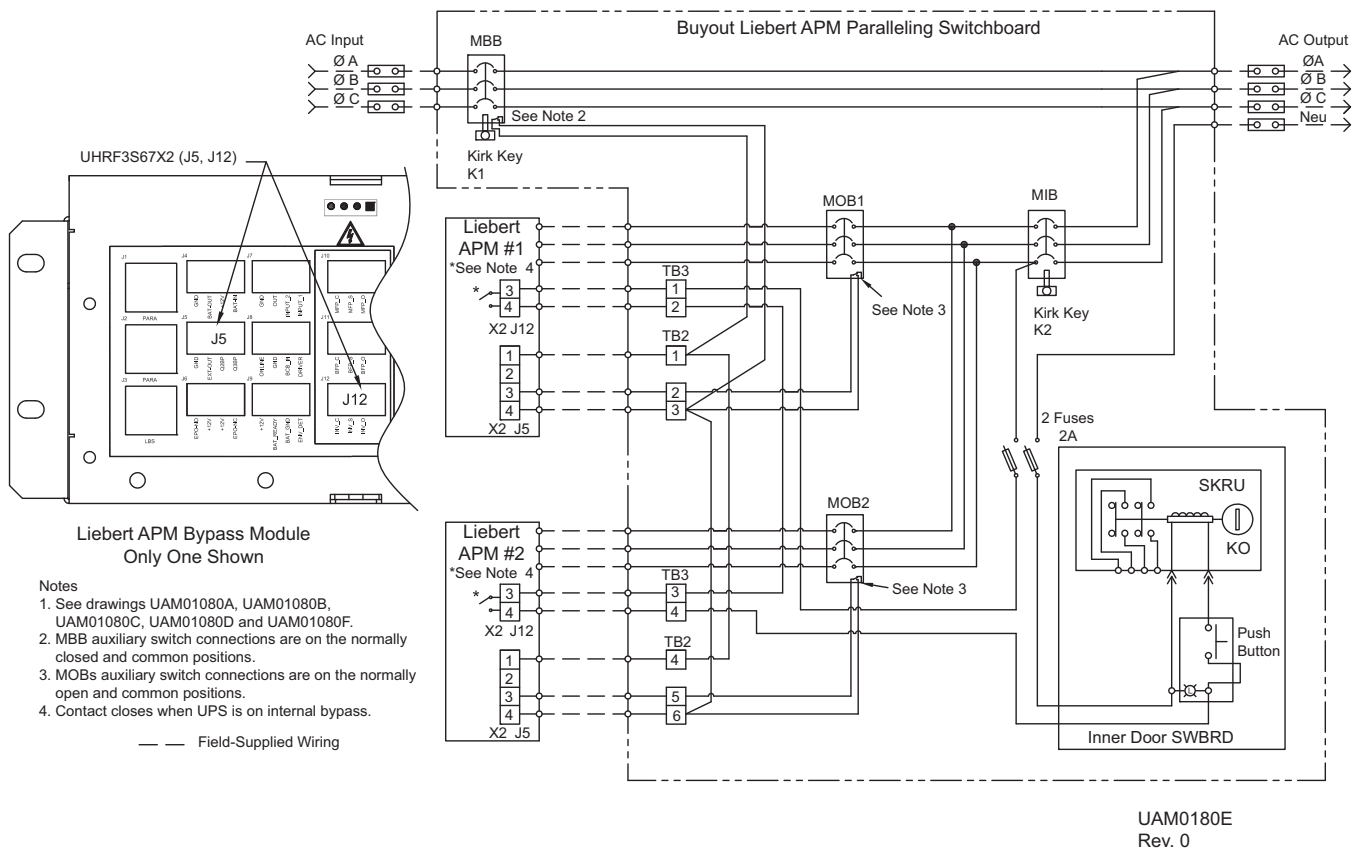

Transfer Parallel Liebert APM Units to System Bypass Mode

1. Verify that all Liebert APM units are in internal maintenance bypass mode. The light in the SKRU push button will turn On when all units are in bypass.
2. Hold the push button in and rotate the key in KO to remove key.
3. Insert key in MBB interlock K1 and rotate to withdraw interlock. Key will remain in interlock.
4. Close the MBB.
5. Open the MIB and rotate the key in K2 to extend interlock.
6. Remove key from MIB interlock K2 and place in KO.
7. Rotate key in KO to lock key.

Return Parallel Liebert APM Units to Normal Mode

1. Verify that all Liebert APM units are in internal maintenance bypass mode. The light in the SKRU push button will turn On when all units are in bypass.
2. Hold the push button in and rotate the key in KO to remove the key.
3. Insert the key in the MIB interlock and rotate the key in K2 to withdraw interlock.
4. Close the MIB.
5. Open the MBB and rotate the key in K1 to extend interlock.
6. Remove the key from the MBB interlock K1 and place it in KO.
7. Rotate the key in KO to lock the key.

Figure 28 Locations of ports J1, J2 and J3 on bypass module

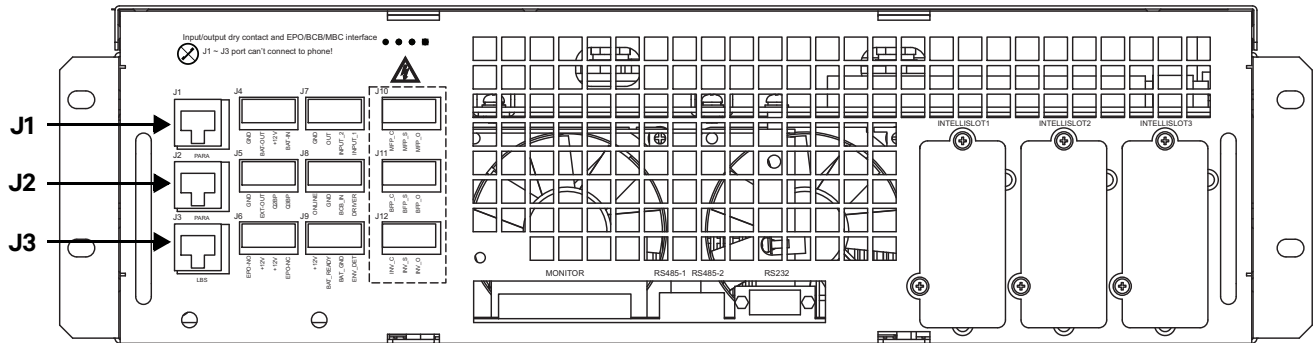

4.2.9 Remote EPO

In addition to the EPO switch provided on the operator control and display panel of each UPS module for controlling the EPO of each module respectively, the parallel system also provides remote EPO function for controlling all UPS modules to shut down simultaneously from a remote terminal, as shown in **Figure 29**.



NOTE

1. The remote EPO switch must provide a dry contact signal, which is normally open or closed.
2. The open circuit voltage provided is 5VDC, <20mA.
3. The external EPO device can be composed of another control system that can disconnect the UPS mains supply or the bypass input.
4. Pins 1 and 2 of the normally closed EPO-J6 port on the bypass module are connected at the factory.

Figure 29 Remote Emergency Power Off wiring for parallel UPS

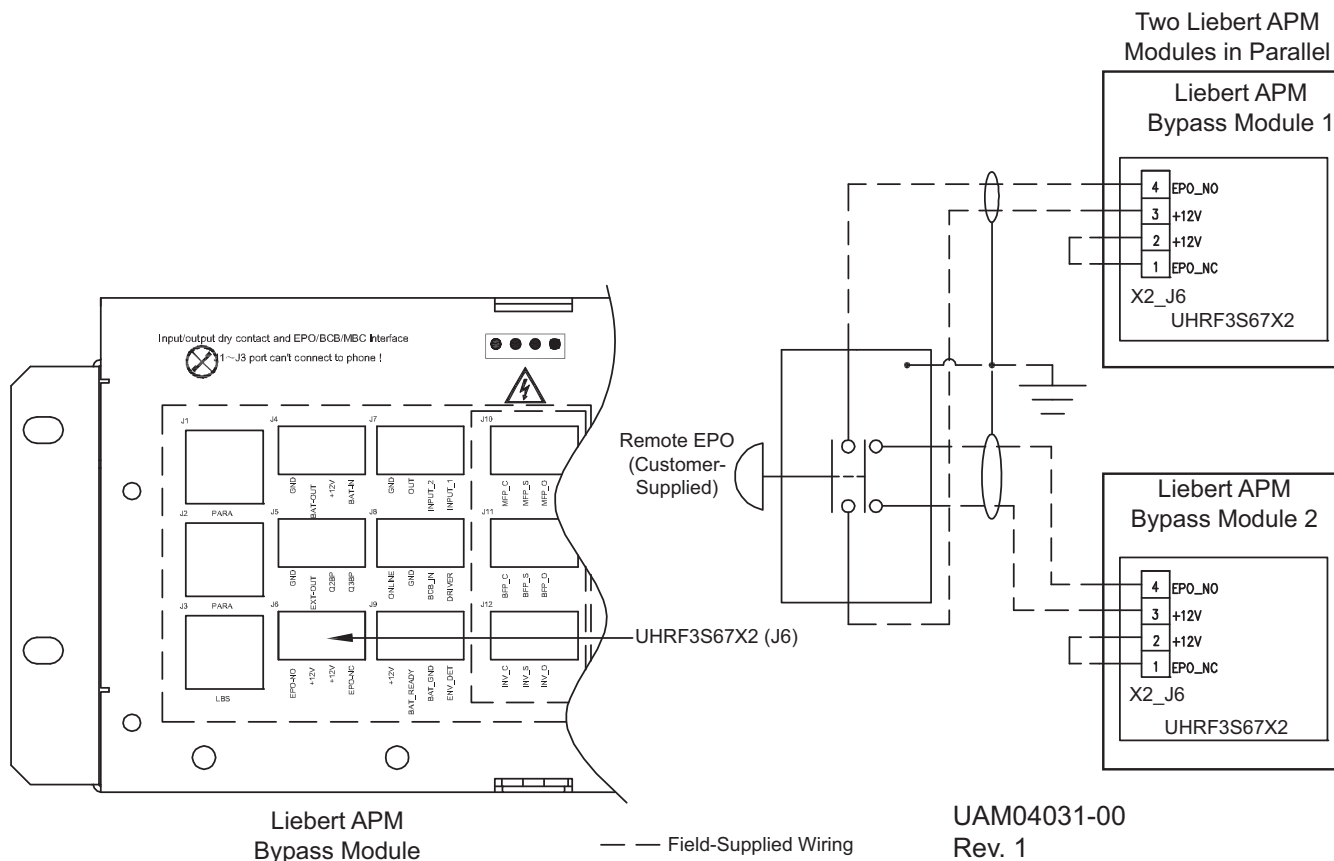

4.3 LBS System

4.3.1 Cabinet Installation

A dual bus system consists of two independent UPS systems, each containing one or more parallel UPS modules, as shown in **Figure 30**. The dual bus system has high reliability and is suitable for loads with multiple input terminals. For a single-input load, an optional static transfer switch can be fitted to achieve the transfer between the two outputs of the dual bus system.

Figure 30 Typical dual bus system (with STS and LBS)

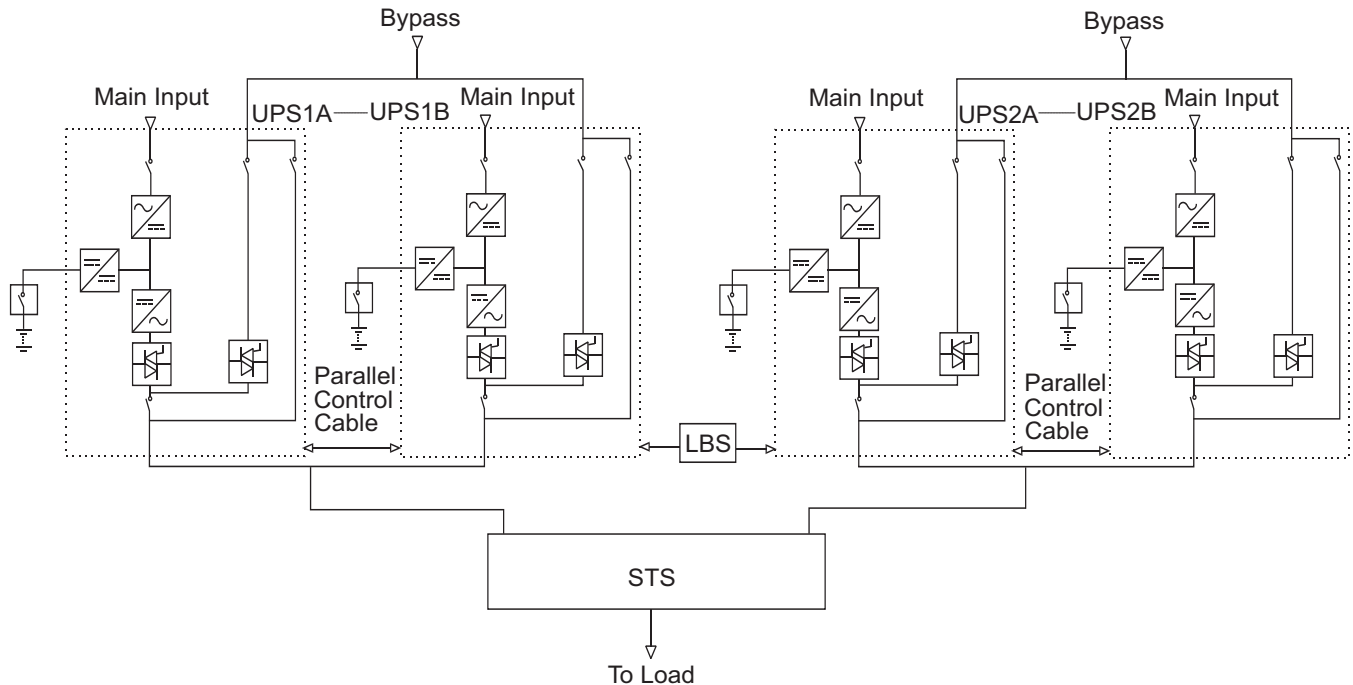

The dual bus system uses the LBS to keep the output of the two independent UPS systems (or parallel systems) in synchronization. One system is designated as the master, the other is designated as the slave. The operation modes of the parallel system comprise master and/or slave operation in normal or bypass mode.

Place the UPS modules side by side and interconnect the UPS modules according to the following instructions.

4.3.2 External Protective Device

Refer to **3.2 - External Protective Devices**.

4.3.3 Power Cable

The power cable wiring is similar to that of the UPS module. Refer to **3.1 - Power Cabling**.

The bypass and rectifier input supplies must use the same neutral line input terminal. If the input has a current leakage protective device, the current leakage protective device must be fitted upstream of the neutral line input terminal.

4.3.4 Control Cable

For Liebert APM-to-Liebert APM dual bus system, connect the optional LBS cables between the two UPS systems as shown in **Figures 31 to 33**. The J3 and J4 ports are provided on the front panel of the bypass module, as shown in **Figures 28**.



NOTE

Use the shortest LBS cable that will be functional for the application and do not coil excess cable. Separate the LBS cable from the power cables to prevent electrical interferences.

Figure 31 Connection of typical dual bus system of two parallel systems

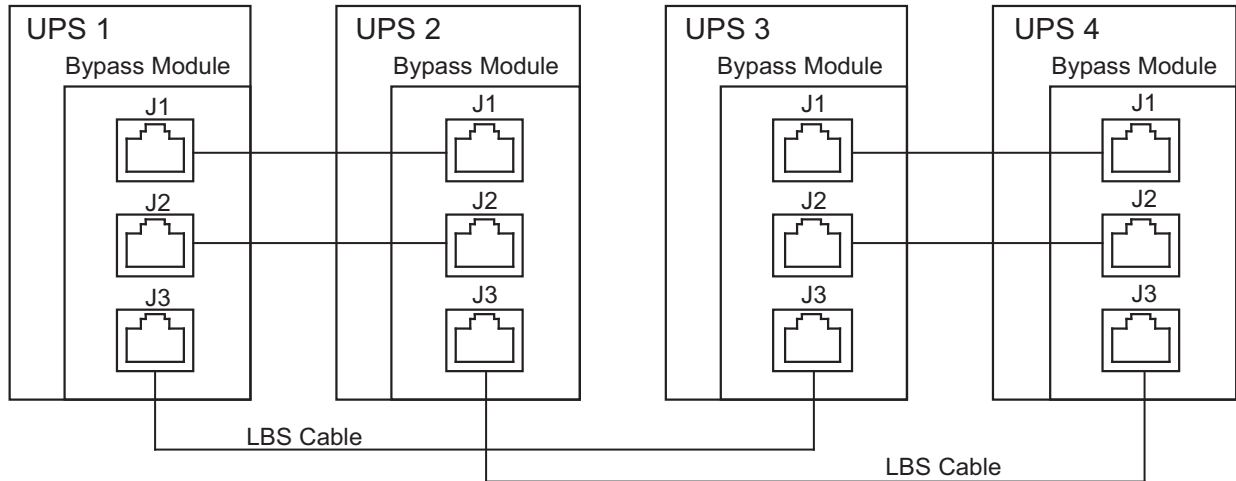

Figure 32 Connection of typical dual bus system of two single UPS's without redundant LBS cable

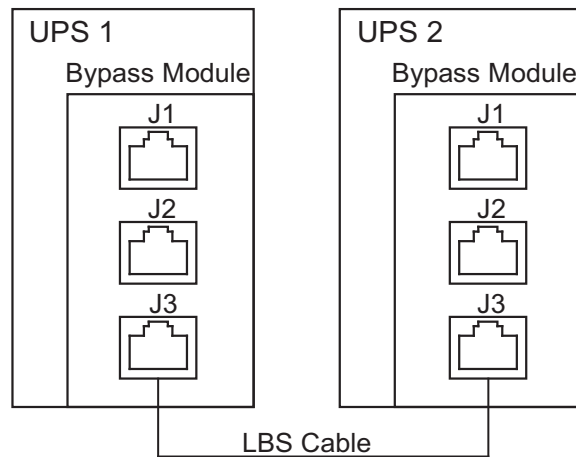
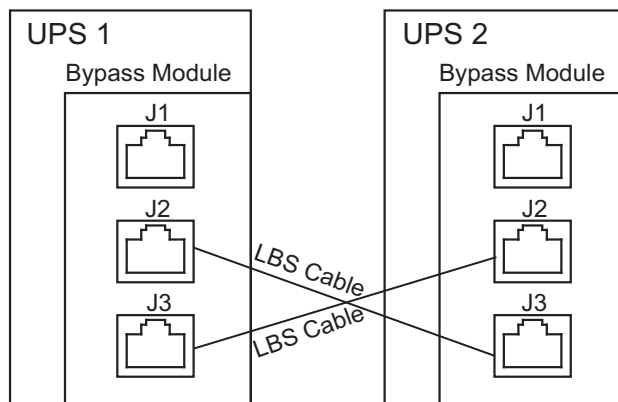

Figure 33 Connection of typical dual bus system of two single UPS's with redundant LBS cable



5.0 BATTERY INSTALLATION

5.1 Introduction

Vertiv recommends that the batteries in external cabinets be the same type and made by the same manufacturer as the internal batteries in the Liebert APM.

If multiple sets of batteries connected in parallel are used to provide the required battery backup run times, fit each set with an isolating device to permit working on one of the battery sets while leaving the others in service and providing backup protection.

5.2 Safety

Special care should be taken when working with the batteries associated with the Liebert APM system equipment.



WARNING

Risk of electrical shock and arc flash. Can cause property damage, injury and death.

The Liebert APM's internal batteries are connected and energized even if the UPS is turned Off. To minimize the risk of injury, a properly trained and qualified service person should disconnect internal batteries before any maintenance is performed on the unit.

When all batteries are connected together, the battery terminal voltage may exceed 324V and is potentially lethal.

The center of the battery is connected to the neutral of the UPS and is grounded.

A battery can present a risk of electrical shock and high short circuit current. The following precautions should be observed when working on batteries:

- Remove watches, rings and other metal objects.
- Use tools with insulated handles.
- Wear rubber gloves and boots.
- Do not lay tools or metal parts on top of batteries.
- Disconnect charging source prior to connecting or disconnecting battery terminals.
- Determine whether the battery is grounded. If the battery is grounded, remove source of the ground. Contact with any part of a grounded battery can result in electrical shock. The likelihood of such shock can be reduced if such grounds are removed during installation and maintenance.

When replacing batteries, replace with batteries of the same type and manufacturer, or equivalent. Refer to **11.2 - UPS Environmental** for a list of approved batteries or contact your Vertiv representative.



CAUTION

Batteries used in the Liebert APM and its auxiliary cabinets must be of an approved type. Replacing batteries with an incorrect type can cause an explosion and fire. Refer to **Tables 38 and 40** for acceptable batteries.

Do not dispose of batteries in a fire. The batteries may explode. Do not open or mutilate batteries. Released electrolyte is harmful to the skin and eyes. It is toxic.

5.3 UPS Batteries—Liebert APM 45kVA Frame Only

The Liebert APM’s internal batteries are fully charged before the unit is shipped. During storage and transportation, some charge is lost. All batteries should be recharged before use. The battery charger works only when the Liebert APM is connected to input power and turned On.



NOTE

Full safety instructions concerning the use and maintenance of UPS batteries are provided in the appropriate battery manufacturer’s manuals, available on the manufacturer’s Web site.

The battery safety information contained in this section relates to key considerations that must be taken into account during the installation design process and might affect the design outcome, depending on your installation.

5.3.1 Internal Battery Breaker Component Locations and Control Wiring

The Liebert APM 45kVA frame contains internal batteries. The batteries are protected by an internal battery breaker. **Figure 34** shows the component location; **Figure 35** shows the control wiring.

Figure 34 Internal battery breaker component locations

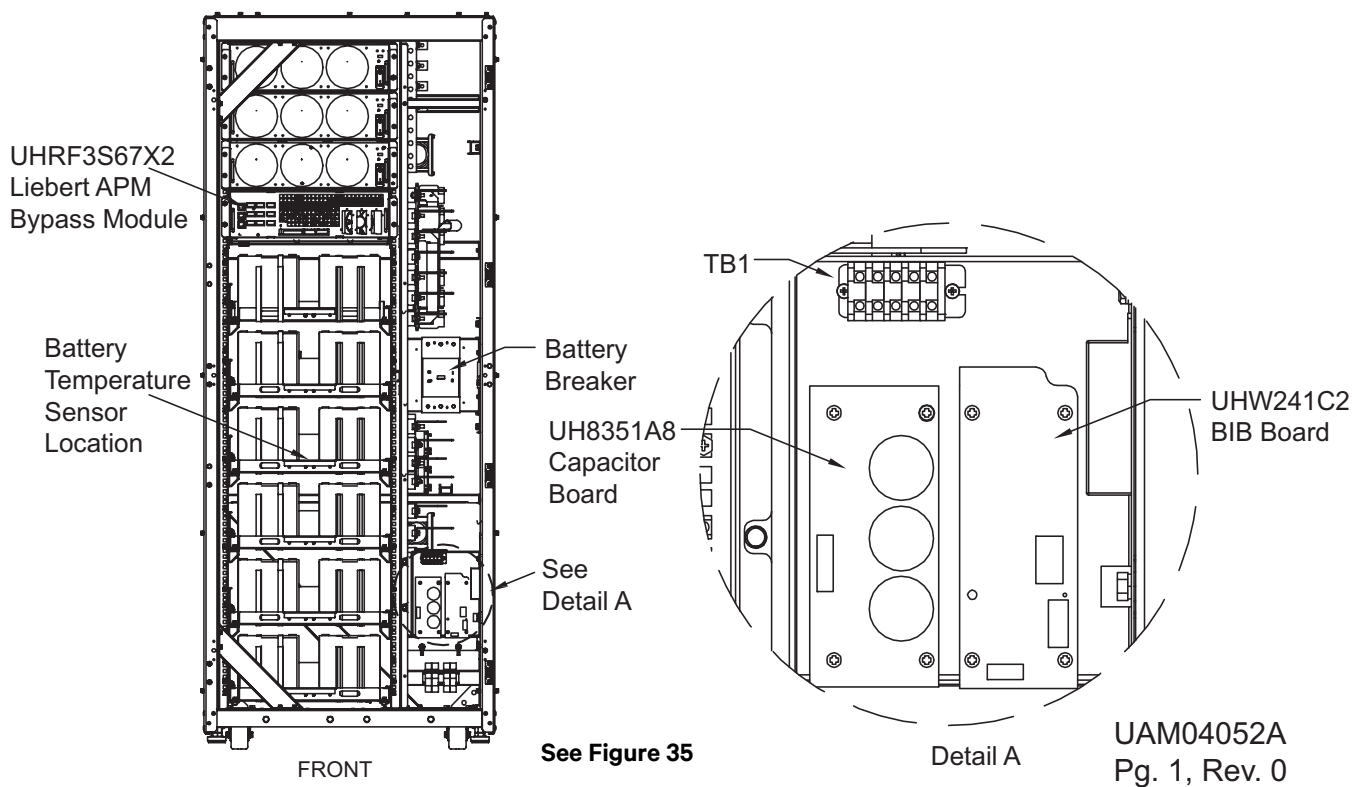
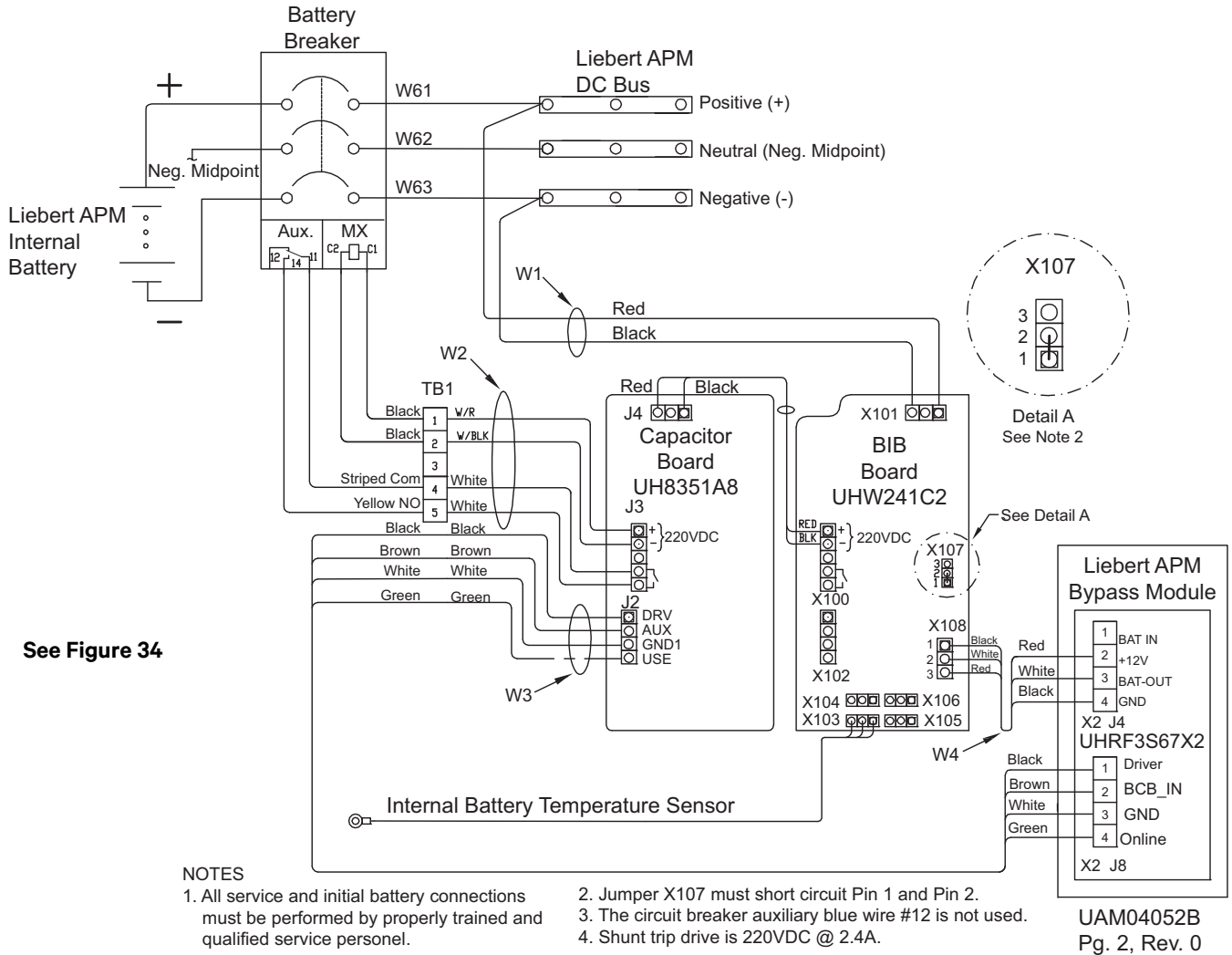

Figure 35 Internal battery control wiring



See Figure 34

5.4 External Battery Cabinet Installation

5.4.1 Matching Battery Cabinets

A matching battery cabinet is available. Refer to **Figure 37**. The same model battery cabinet may be installed in parallel in multiple cabinet strings for additional capacity. Battery run time depends on the cabinet model, the number of cabinets and the load on the UPS.

Handling—The battery cabinet has casters to facilitate movement over short distances. The bottoms of the battery cabinets are reinforced to permit movement by forklift over longer distances.

Inspection—Remove all panels and visually inspect the batteries, bus connections, and cabinet for any damage. Exercise caution; voltage is present within the battery cabinet even before installation. If there are signs of damage, do not proceed. Call Vertiv at 1-800-543-2378.

Storage—The batteries can be stored for up to six months without appreciable deterioration. If planning to store a battery cabinet for longer than six months or at temperatures higher than 77°F (25°C), contact Vertiv for recommended precautions.

The following notes, in conjunction with the diagrams (**Figure 37**), illustrate the broad principles to be followed when fitting and connecting the majority of battery cabinet installations.

CAUTION

Any battery system should be installed by properly trained and qualified personnel.

When installing an external battery cabinet that is NOT a Liebert APM battery cabinet, the customer must provide overcurrent protection. See **Table 43** for sizing of protection devices.



NOTE

*When using an external battery supply that is not provided with the UPS, please make reference to the battery manufacturer's installation manual for battery installation and maintenance instructions, available on the manufacturer's Web site. When replacing batteries, Vertiv recommends that the batteries in external cabinets be the same type used internally in the Liebert APM. See **Tables 38 and 40** for batteries that are approved for use with the Liebert APM.*

Figure 36 Bolting the battery cabinet to the Liebert APM

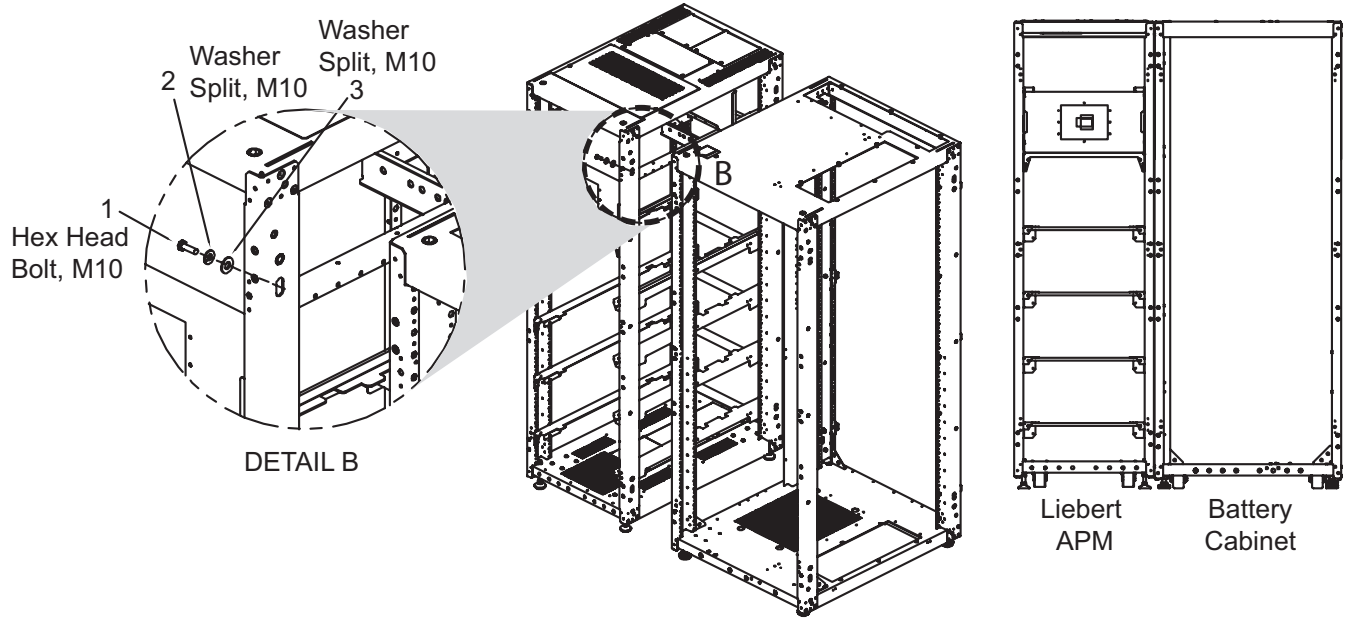

5.4.2 Connecting the Batteries

If the Liebert APM battery cabinets are installed on a raised floor, the battery power cables and circuit breaker control cables may be routed to the UPS cabinet through the bottom of the cabinet.

If the Liebert APM battery cabinets are installed adjacent to one another on a solid floor, these cables may be passed between the cabinets through slots in the lower sides of the cabinets. Intertray connections must be made before the battery cabinet may be used.

Figure 37 Battery cabinet, 600mm wide—details

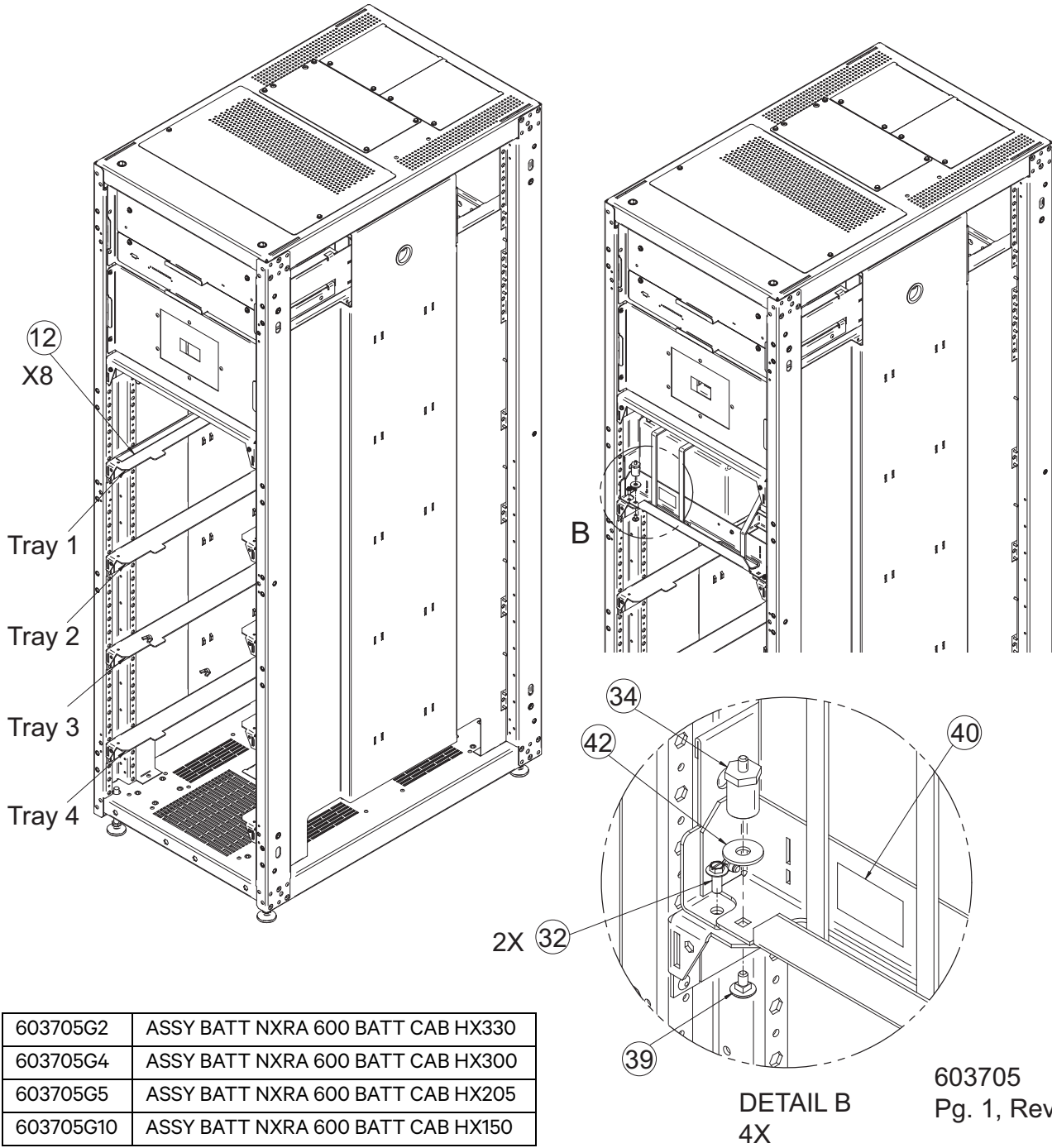

Figure 38 Battery trays for 600mm battery cabinet

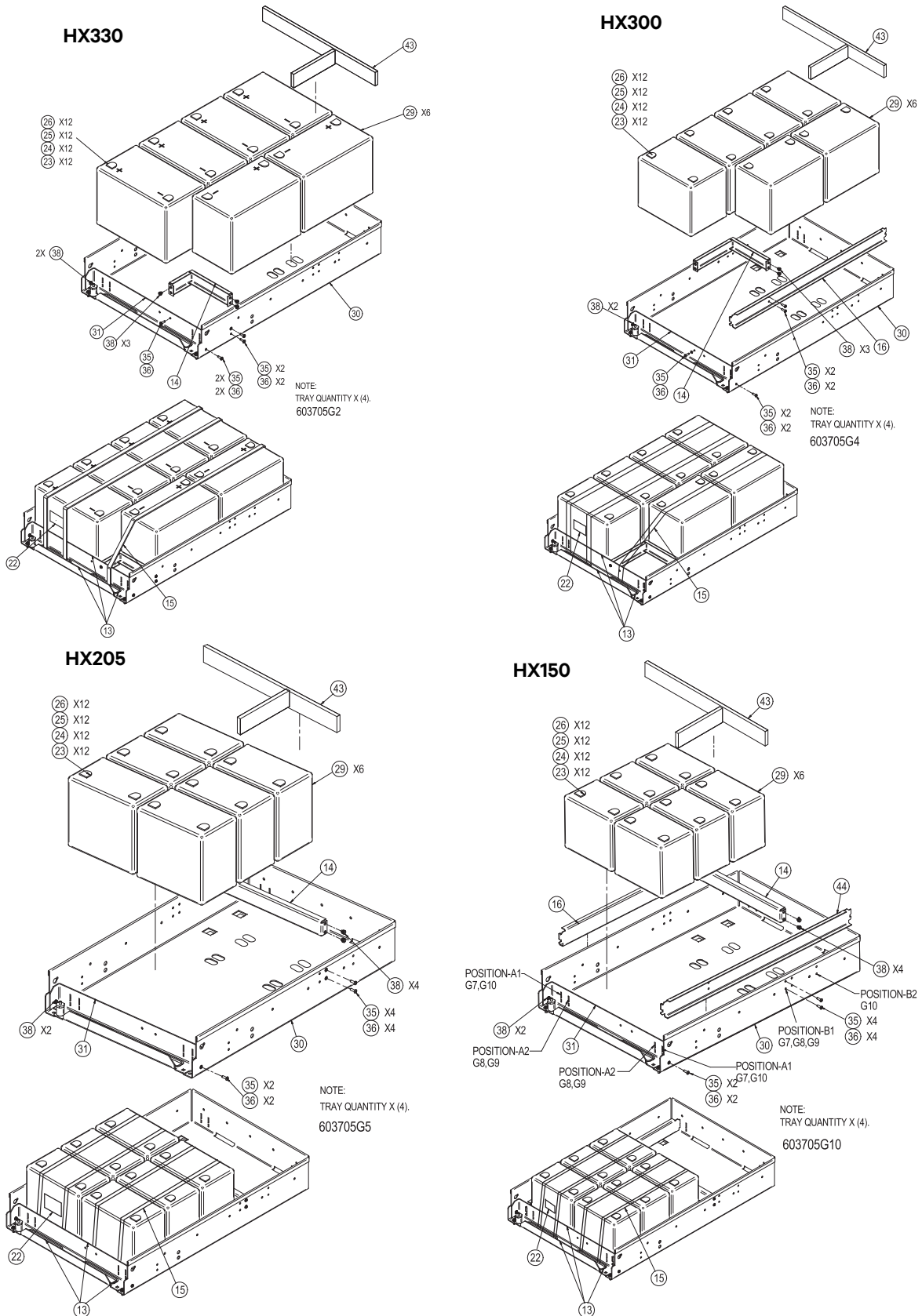
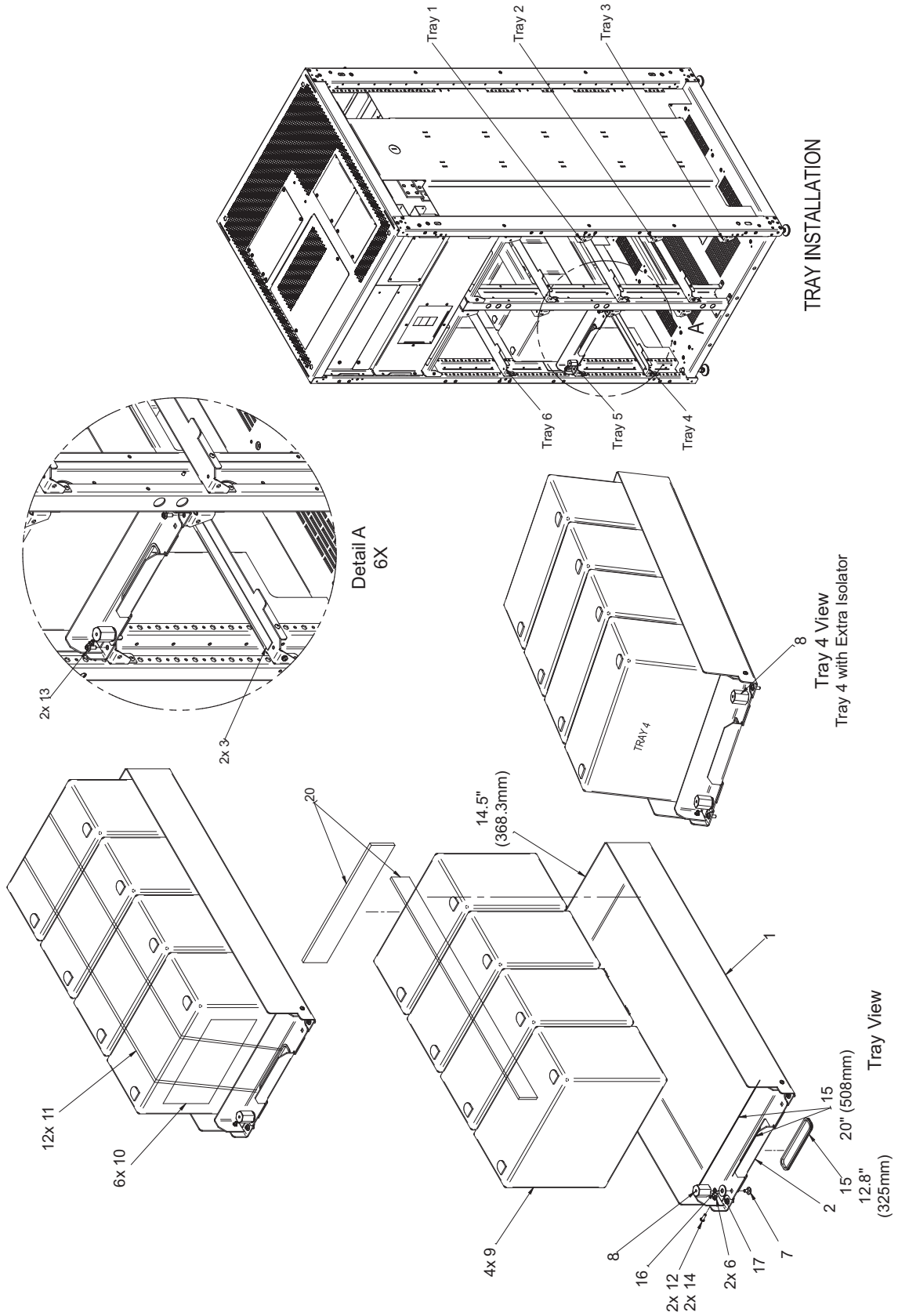

Figure 39 Battery cabinet with trays for 900mm battery cabinet



5.4.3 Installation Considerations

Position—Liebert battery cabinets come in versions specific to the left side of the UPS. If the system includes a matching Liebert BDC, the cabinet should be mounted to the right of the UPS (nearest the busbars) and the battery cabinet(s) should be installed to the left of the UPS.

The battery cabinet(s) are designed to be located conveniently next to each UPS module on the left side only and are also available in stand-alone configurations with painted side panels. The front access design eliminates side and rear service clearance requirements. Refer to **Table 36** for battery cabinet dimensions and weights.

Bolt-On Cabinets—Matching battery cabinets are designed to bolt only onto the left side of the UPS module cabinet. Use bolts that ship with each unit to connect cabinet frames at posts, two places in the front and two places in the rear.

Service Clearance—Allow front access to the battery cabinet at all times for maintenance and servicing. Electrical codes require that the battery cabinet be installed with no less than 3 feet (1m) of clearance at the front of the cabinet when operating. Side and rear panels do not require service clearance.

Cables—Cables may be run between the cabinets through cutouts in the top of the cabinet, eliminating the need for external conduit runs. Route cables before moving cabinets into final position for bolting together. No top or bottom entry cables are required, except for remotely located cabinets which require conduits.

Software—To allow the UPS to accurately display the battery run time, the number of battery cabinets must be noted when performing initial startup and setup using the configuration software. This is to be performed by the Vertiv engineer when commissioning the unit.

Casters and Adjustable Stops—The adjustable stops are not designed to bear the full weight of the cabinet. Lower the stops until they are finger-tight in contact with the floor. Then tighten a small amount with a wrench (less than two turns) to give a good friction fit. When mounting the battery cabinet on seismic stands, ensure that the casters are bearing the weight of the cabinet.

5.4.4 Connecting the Battery Cabinet to the UPS

After the battery cabinet equipment has been positioned and secured for operation and the batteries have been connected, connect the power cables as described below (see **Figure 40**).

1. Verify that all incoming high and low voltage power circuits are de-energized and locked out or tagged out before installing cables or making any electrical connections.
2. Remove the UPS right side panel to gain access to the ground and battery busbars.
3. Remove the battery cabinet front panel to gain access to the busbars.
4. Connect the safety ground and any necessary bonding ground cables to the copper ground busbar. (example: UPS located on the bottom of the equipment below the power connections).

All cabinets in the UPS system must be connected to the user's ground connection.



NOTE

The grounding and neutral bonding arrangement must be in accordance with the National Electrical Code and all applicable local codes.

5. Connect the system battery cables from the UPS battery terminals (+ N -) to battery cabinet breaker BCB (+ N -) as shown in **Figure 40**. Be sure that the battery connections are made with the right polarity, and

tighten the connections to 240lb-in. (27N-m) (M10 bolt). Do not close the battery circuit breaker before the equipment has been commissioned.

6. Connect TB1 from battery cabinet to J4 and J8 on the UPS according to **Table 9**.

**NOTE**

The shunt trip drive capability for the battery breaker is 220VDC at 2.4A.

Table 9 Control wiring for Liebert APM to battery cabinet

From	To
Liebert APM UPS Bypass Module (X2 J4 & J8)	Battery Cabinet Terminal Strip (TB1)
J4-2	TB1-12
J4-3	TB1-11
J4-4	TB1-10
J8-1	TB1-6
J8-2	TB1-7
J8-3	TB1-8
J8-4	TB1-9

Figure 40 Battery cabinet connection to Liebert APM

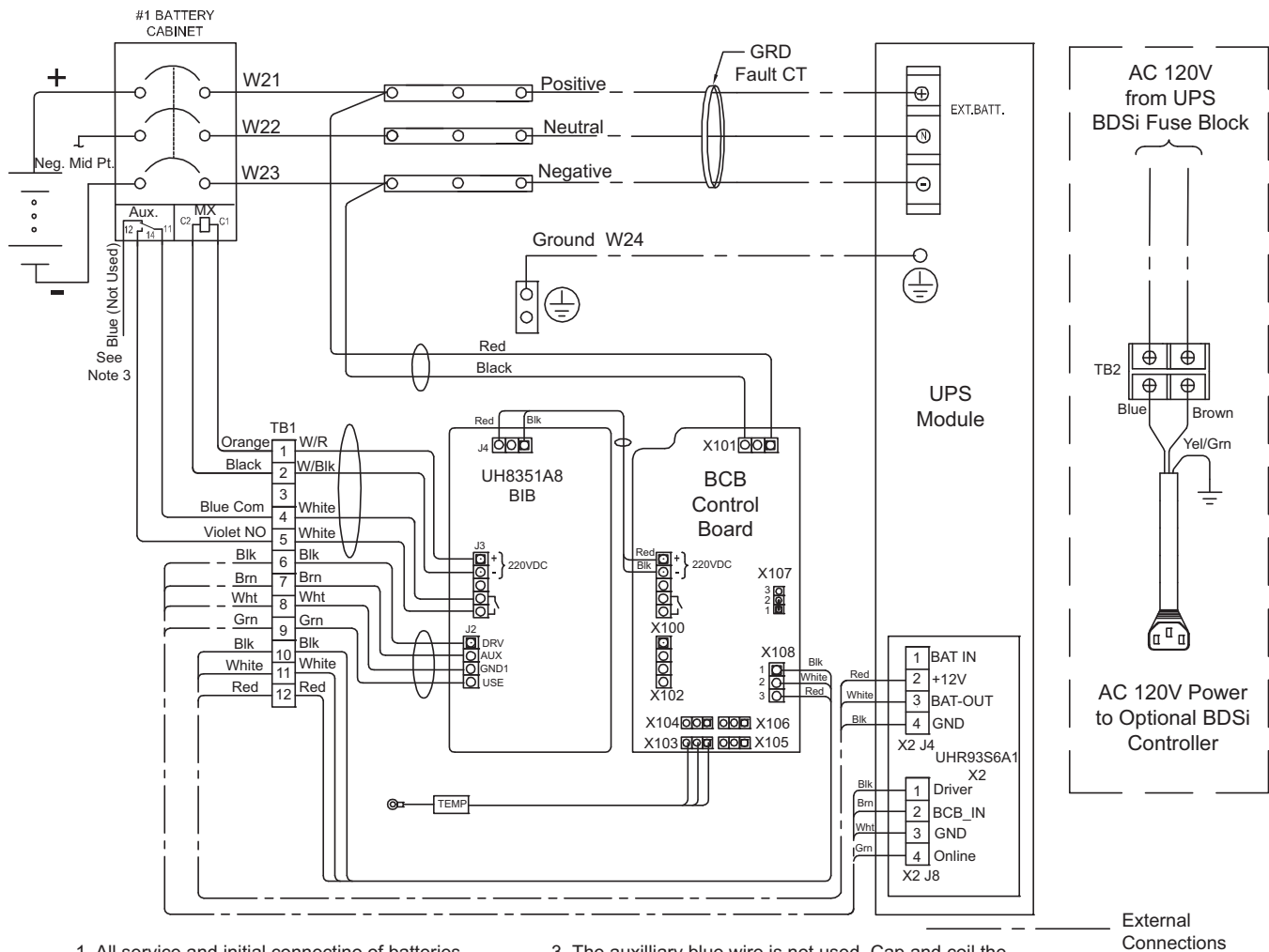

1. All service and initial connectino of batteries must be performed by properly trained and qualified service personnel.
2. The Jumper X107 must short circuit Pin 1 and Pin 2.
3. The auxilliary blue wire is not used. Cap and coil the wire and tie it to the bridge lance on the frame below the breaker.
4. Shunt trip drive is 220VDC @ 2.4A.

External Connections

UAM04000
Rev. 0

5.5 Non-Standard Batteries

When batteries other than a matching battery cabinet are used, a remote battery disconnect switch with overcurrent protection is required per the National Electrical Code. Contact your local Vertiv sales representative about this option. Refer to **Figures 86** and **87** for details.

Install battery racks, cabinets and batteries in accordance with the manufacturer's instructions. Verify that the battery area has adequate ventilation and battery operating temperature complies with the manufacturer's specifications and with all applicable national and local codes. If you have any questions concerning batteries, battery racks or accessories, contact Vertiv at 1-800-543-2378.



NOTE

The user-supplied battery DC bypass breakers or fuses should have a minimum overload rating of 8kA and 500V.

5.6 Battery Ground Fault Detection Option

An optional battery ground fault detection device can be added to detect leakage current in the battery system. The residual current range monitored is 30mA ~ 3000mA. When a battery ground fault is detected, an alarm will appear on the UPS display panel. The battery ground fault detection set contains one current transformer (CT). **Figures 41 and 42** show the connection of this set for the Liebert APM.

Figure 41 Battery ground fault detection component location

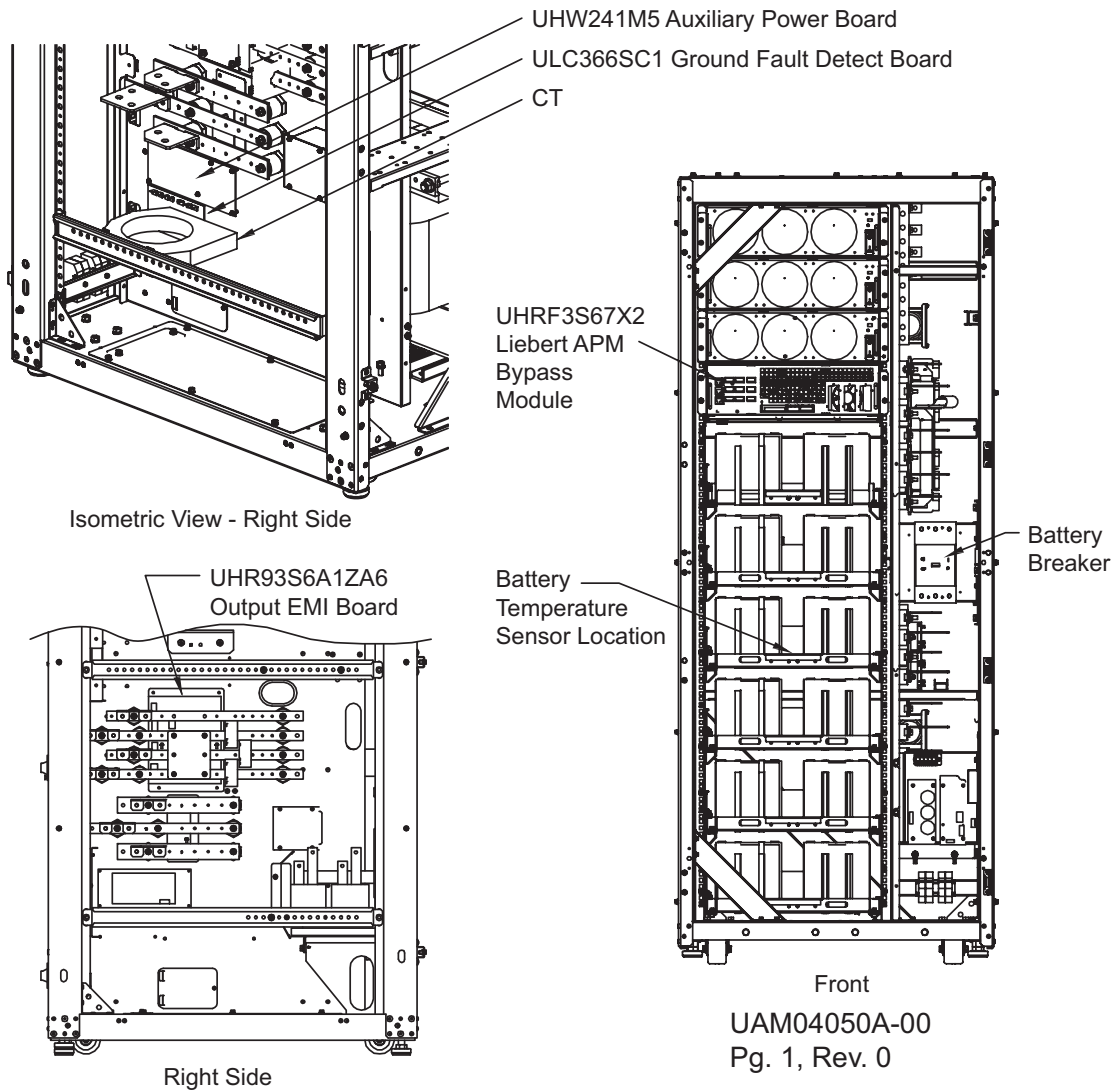
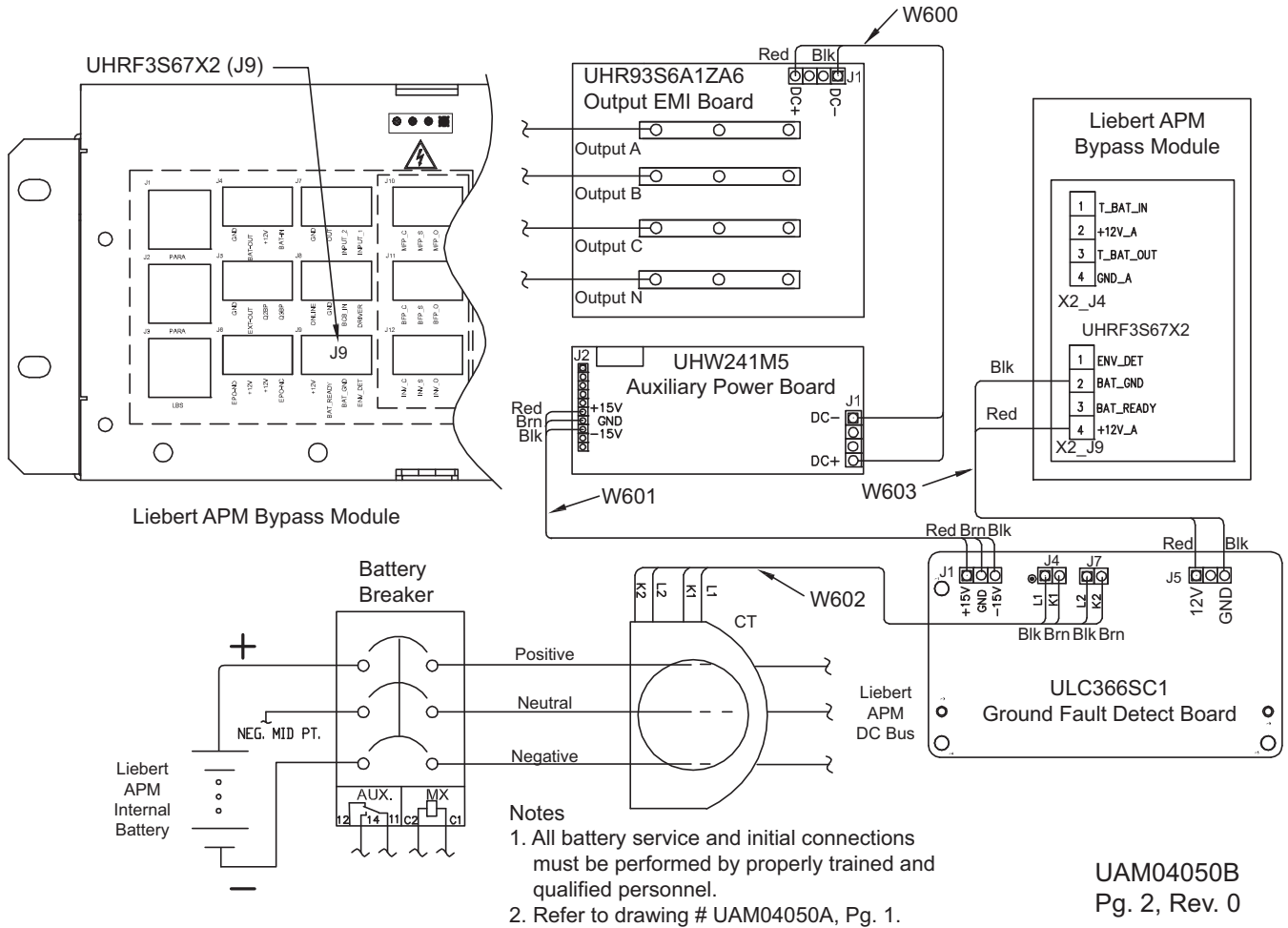

Figure 42 Control wiring diagram for battery ground fault detection option



UAM04050B
Pg. 2, Rev. 0

6.0 LIEBERT BDC™

The Liebert BDC is designed to operate in UPS normal mode, static bypass mode and maintenance mode. The Liebert BDC offers either 45kVA or 90kVA capacity to match the associated Liebert APM frame offerings. Each of the Liebert BDC capacities offer optional input 208V, 480V and 600V internal transformers as well as multiple output distribution selections.

Figure 43 Single input UPS with external Liebert BDC with optional internal transformer—typical configuration

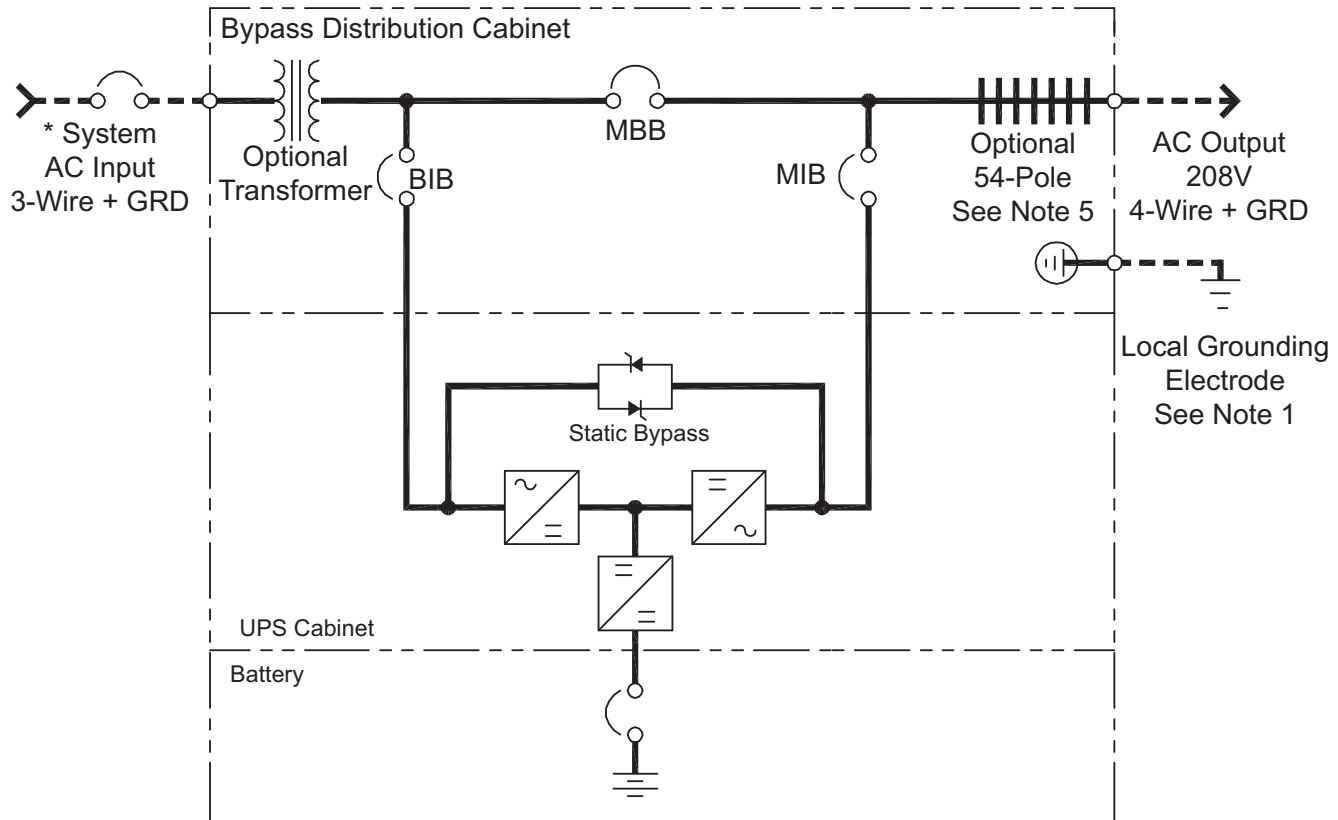

Notes

1. Install in accordance with national and local electrical codes.
2. Input and bypass must share the same single source.
3. UPS system input and output cables must be run in separate conduits.
4. Control wiring must be run in separate conduits.
5. Optional 54-pole, 225A for 45kVA frame only or optional 54-pole, 400A for 90kVA frame only.
6. Transformer available: 480V or 600V input.

BIB - Bypass Isolation Breaker
 MBB - Maintenance Bypass Breaker
 MIB - Maintenance Isolation Breaker
 * External Overcurrent Protection by Others
 - - - - Field-Supplied Wiring

UAM01004
 Rev. 3

6.1 Normal (UPS) Mode

While the Liebert BDC is in Normal mode (MBB open; BIB/MIB closed), the UPS is supplying the connected load with continuous, high-quality AC power. In this mode of operation, the load is protected by the UPS.

6.2 UPS Static Bypass Mode

When the Liebert APM is in Static Bypass mode, it provides an alternate path for power to the connected equipment. Should the UPS need to be taken out of service for limited maintenance or repair, manual activation of the Static Bypass will cause an immediate transfer of the equipment from the UPS inverter to the bypass source. In this mode, power will still be supplied to the UPS; however, the load is NOT protected by the UPS.

6.3 Maintenance Mode

When the Liebert BDC is in Maintenance mode (MBB closed; BIB/MIB open), it provides an alternate path for power to the connected equipment should the UPS need to be taken out of service for limited maintenance or repair. In this mode of operation, no power is supplied to the UPS and the load is NOT protected by the UPS.

6.4 Locating the Cabinet

This Liebert BDC may be mounted to the left of the UPS or installed as a stand-alone unit. In either case, ensure that the unit is in a well-ventilated area and that there is clearance for access to the switches and cable connections as required by national and local codes.

6.5 Cable Installation

6.5.1 Wiring Preparation

Be sure that the unit is not connected to any AC utility power source or UPS before installing any wiring to this unit. This Liebert BDC should be installed by a qualified / certified electrician.



WARNING

Risk of electrical shock and arc flash. Can cause property damage, injury and death. Read this section thoroughly before attempting to install wiring to this unit. Read and comply with all warnings and cautions in this manual.

Removing the Cover Plates

Plates cover the input and output terminals on the front of the Liebert BDC (see **Figure 44**). Remove these and keep the screws and plates for reinstallation.

Figure 44 Liebert BDC—access plate removed

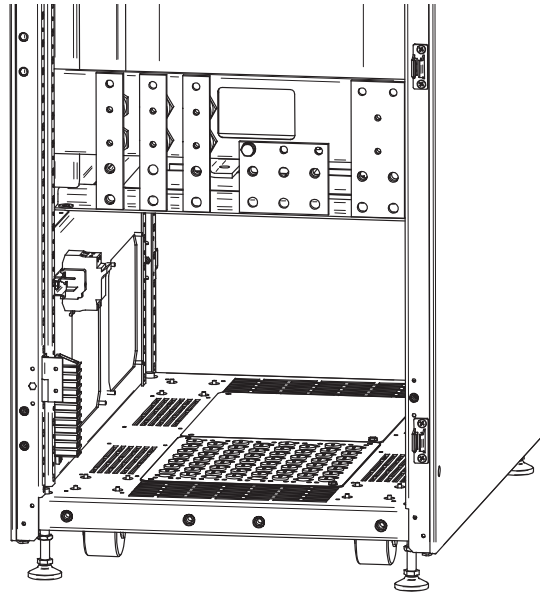

6.5.2 Power Cable Installation

Refer to **Table 43** when selecting cables.



NOTE

Transient and steady state earth leakage currents may occur when starting the equipment. This should be taken into account when selecting ground current detection devices because these will carry the earth leakage currents of both the UPS equipment and the load.

6.5.3 Input/Output Wiring

Follow the steps below to connect the input wiring:



NOTE

Input wiring must be installed using conduit if cabinet is not mounted to the immediate right of the UPS.

1. Locate the input wiring access (top or bottom access), remove the conduit landing plate and punch the appropriate size hole for the size conduit being used. Pull the three/four input wires through it, allowing some slack for installation. For cabinets that are located to the immediate left of the UPS, the access plate

is on the lower right of the cabinet. Remove the access plate and verify that the edge guarding is installed and intact.

2. Secure the conduit to the access plate of the Liebert BDC.
3. Input power cables connect to the system input circuit breaker; refer to **Figure 59** and to **Table 18**.
4. Connect the ground (earth) wire to the earth busbar and tighten it to 240lb-in. (27N-m) (M10 bolt).
5. Locate UPS input and output cables and access panel to UPS on lower right side.



NOTE

If the Liebert BDC is not to be bolted to the UPS, use either top or bottom access plate.

6. Connect the system ground cable between the Liebert BDC and UPS and tighten the connections to 240lb-in. (27N-m) (M10 bolt).
7. Connect the system input cables between the Liebert BDC “UPS Input” Busbars (A-B-C N terminals) and UPS input busbars (A-B-C N terminals) and tighten the connections to 240lb-in. (27N-m) (M10 bolt).
8. Connect the system output cables between the Liebert BDC 'UPS Output' Busbars (A-B-C N terminals) and UPS output busbars (A-B-C N terminals) and tighten the connections to 240lb-in. (27N-m) (M10 bolt).
9. Connect TB1 from the Liebert BDC to J5 and J12 on the Liebert APM.

NOTICE

Risk of improper wiring connection. Can cause equipment damage.

The control wire must be installed to ensure proper operation of the system and fully protect the load when switching between bypass cabinet and UPS.

Table 10 Control wiring for Liebert APM UPS to Liebert BDC

From	To
Liebert APM UPS Bypass Module (X2 J5 & J12)	Liebert BDC Terminal Strip (TB1)
J12-3	TB1-11
J12-4	TB1-12
J5-1	TB1-3
J5-3	TB1-6
J5-4	TB1-5
	Jumper TB1-4 to TB1-5

Figure 45 BDC connection to Liebert APM

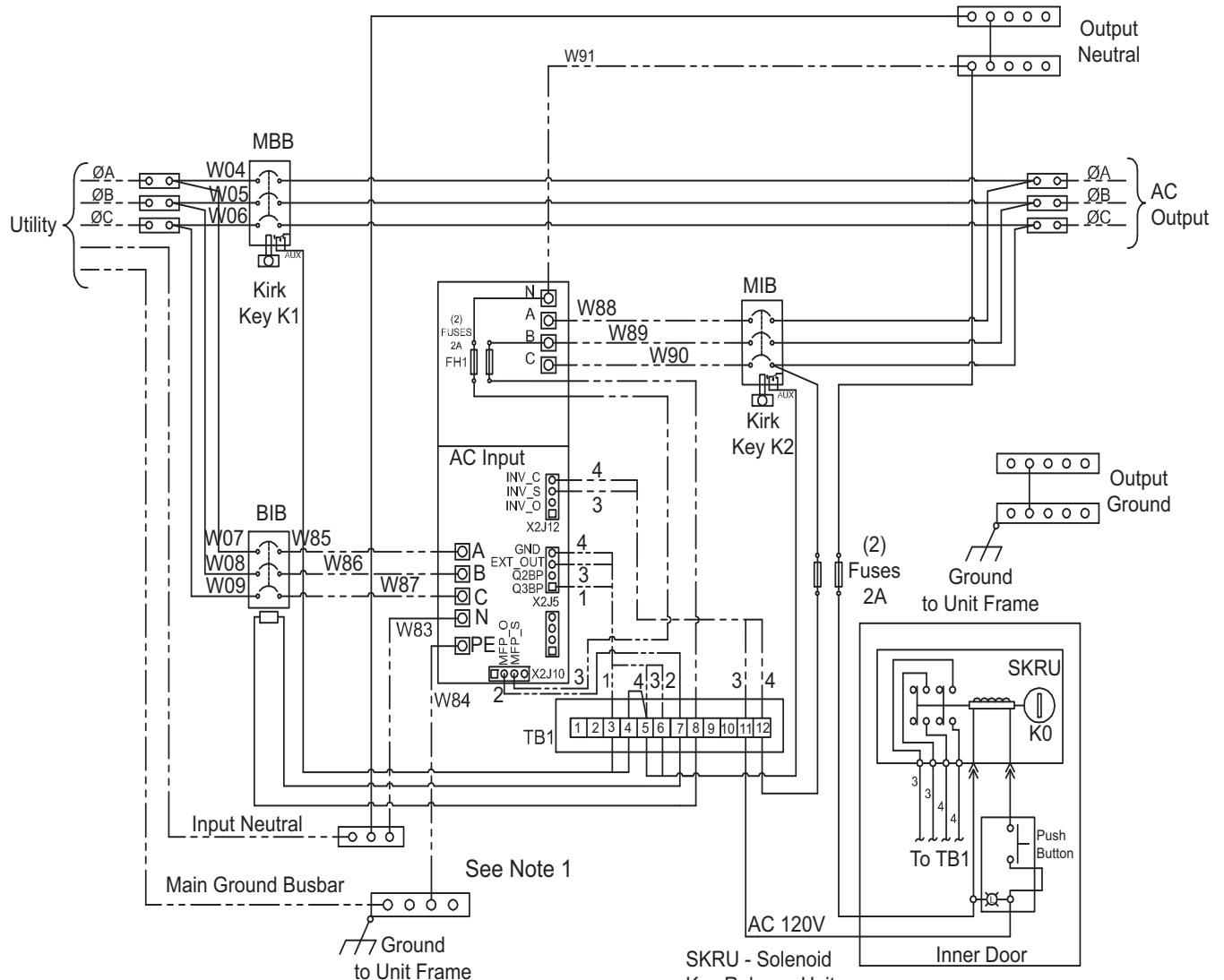

1. Customer-furnished electrode conductor to be installed in accordance with national and electrical codes.

SKRU - Solenoid Key Release Unit
 KO - Key Operator
 - - - Field-Supplied Wiring UAM04012
 ——— Factory-Supplied Wiring Rev. 4



NOTE

Install jumper on TB1 pins 4 and 5.
 For startup procedure, see **10.2 - UPS Startup**.

6.6 Bolting Cabinets Together



NOTE

UPS wiring must be completed before the cabinets are bolted together.

1. Line up cabinets so that mounting holes are aligned.

Figure 46 Bolting Liebert APM to a Liebert BDC

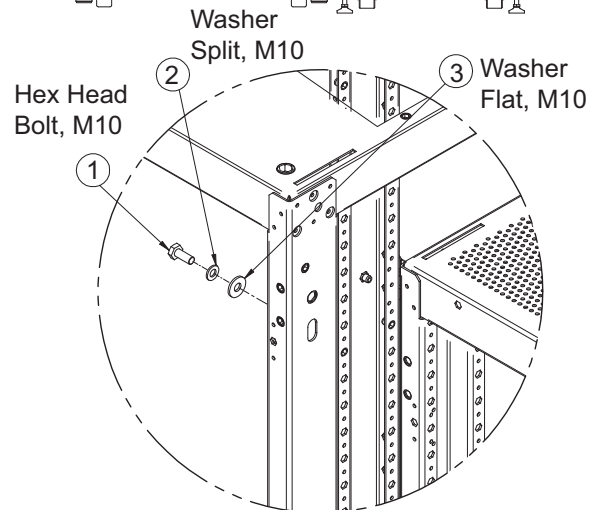
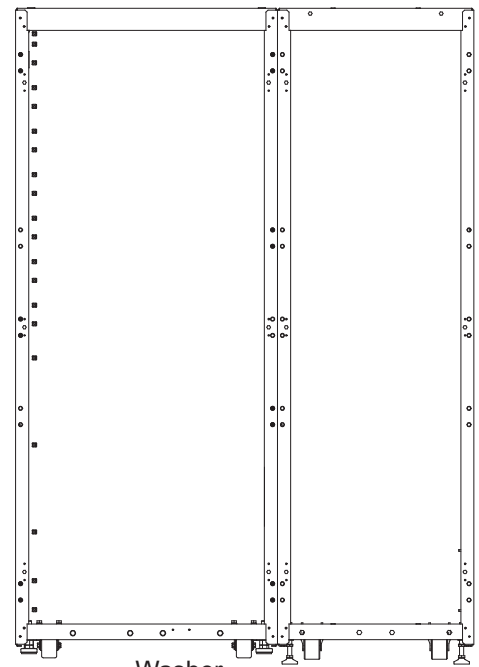
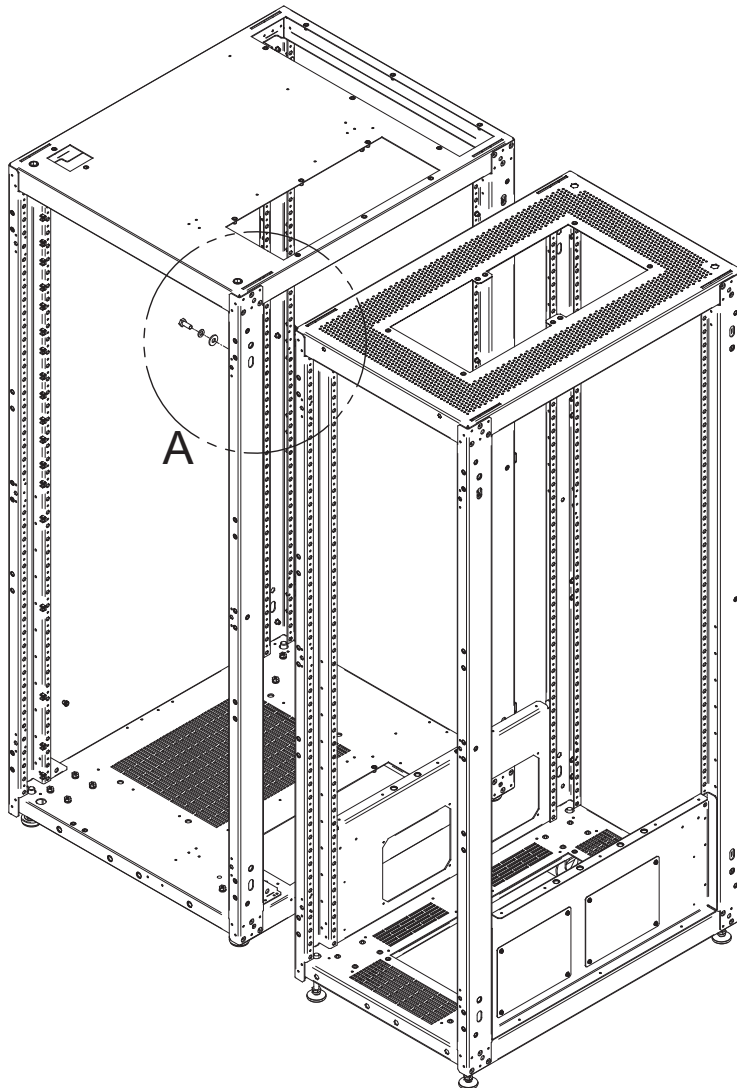

Hardware for bolting units is in a bag attached to the Liebert BDC. See form included with UPS.

Place cabinets so mounting holes are aligned.

A bolt from the adjacent cabinet may be screwed into the threaded top hole, or a bolt may be inserted through the lower hole and screwed into the threaded hole in the adjacent cabinet.

2. Using supplied hardware, bolt the cabinets together. The bolts may be inserted from either the UPS side or from the Liebert BDC side, whichever is more convenient.

7.0 INSTALLATION DRAWINGS

The diagrams in this section illustrate the key mechanical and electrical characteristics of the Liebert APM UPS System cabinets (UPS, Liebert BDC and battery).

Figure 47 UPS dimensions- front view

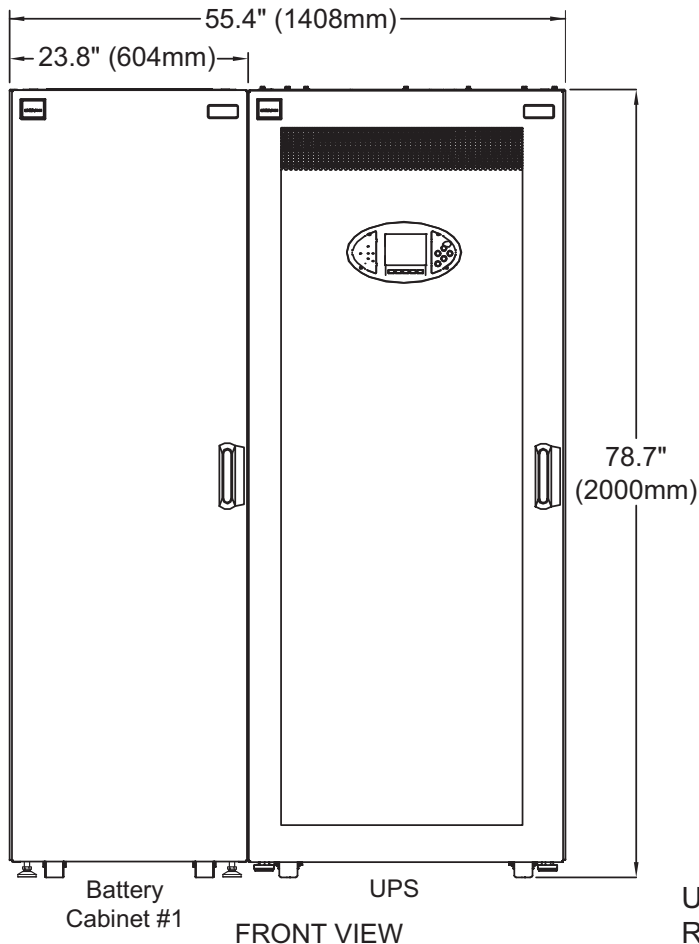

1. All dimensions are in inches (mm).
2. 24" (610) minimum clearance above unit;
36" (914) front access required for service.
3. Keep cabinet within 15 degrees of vertical.
4. Top and bottom cable entry available through removable access plates.
Remove, punch to suit conduit size and replace.
5. Unit bottom is structurally adequate for forklift handling.
6. Control wiring and power wiring must be run in separate conduits.
7. Copper cables only are recommended.
8. All wiring is to be in accordance with national and local electrical codes.
9. All battery cabinets must be positioned on the left side of the UPS.

Total Width with Additional Battery Cabinets

Number of Battery Cabinets	Total Width In. (mm)
2	79.1 (2008)
3	102.7 (2608)
4	126.3 (3208)

UAM03000
Rev. 0

Figure 48 Lineup arrangement, Liebert APM with battery and Liebert BDCs

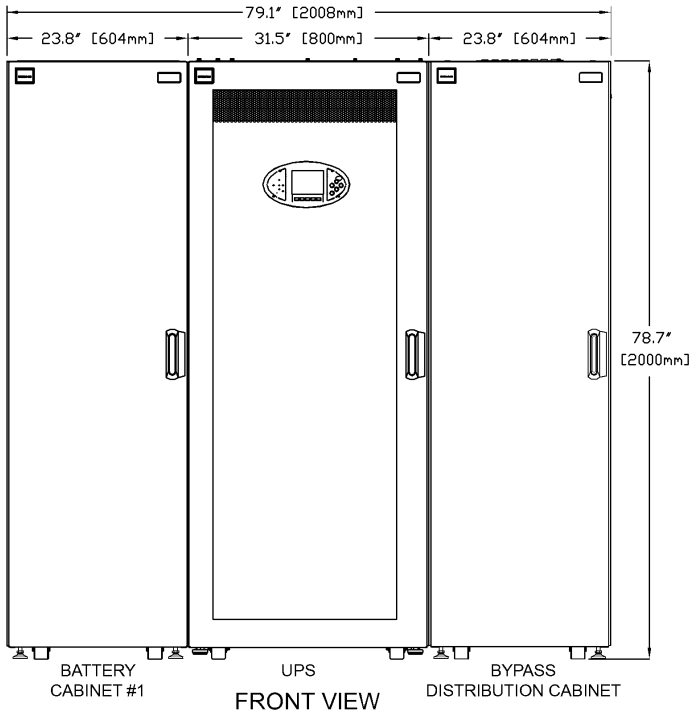

NOTES:

1. ALL DIMENSIONS ARE IN inches [mm].
2. 24" [610] MINIMUM CLEARANCE ABOVE UNIT AND 12" [305] REAR CLEARANCE REQUIRED FOR AIR EXHAUST. 36" [914] FRONT ACCESS REQUIRED FOR SERVICE.
3. KEEP CABINET WITHIN 15 DEGREES OF VERTICAL.
4. TOP AND BOTTOM CABLE ENTRY AVAILABLE THROUGH REMOVABLE ACCESS PLATES. REMOVE, PUNCH TO SUIT CONDUIT SIZE AND REPLACE.
5. UNIT BOTTOM IS STRUCTURALLY ADEQUATE FOR FORKLIFT HANDLING.
6. CONTROL WIRING AND POWER WIRING MUST BE RUN IN SEPARATE CONDUITS.
7. COPPER CABLES ONLY ARE RECOMMENDED.
8. ALL WIRING IS TO BE IN ACCORDANCE WITH NATIONAL AND LOCAL ELECTRICAL CODES.
9. ALL BATTERY CABINETS MUST BE POSITIONED ON THE LEFT SIDE OF UPS.
10. MAINTENANCE BYPASS MUST BE POSITIONED ON THE RIGHT SIDE OF UPS.

TOTAL WIDTH WITH ADDITIONAL BATTERY CABINETS	
NO. OF BATT. CABINETS	TOTAL WIDTH
2	102.7 [2608]
3	126.3 [3208]
4	149.9 [3808]

**UAM03001
Rev. 1**

Figure 49 UPS dimensions continued, center of gravity—side, top and bottom views

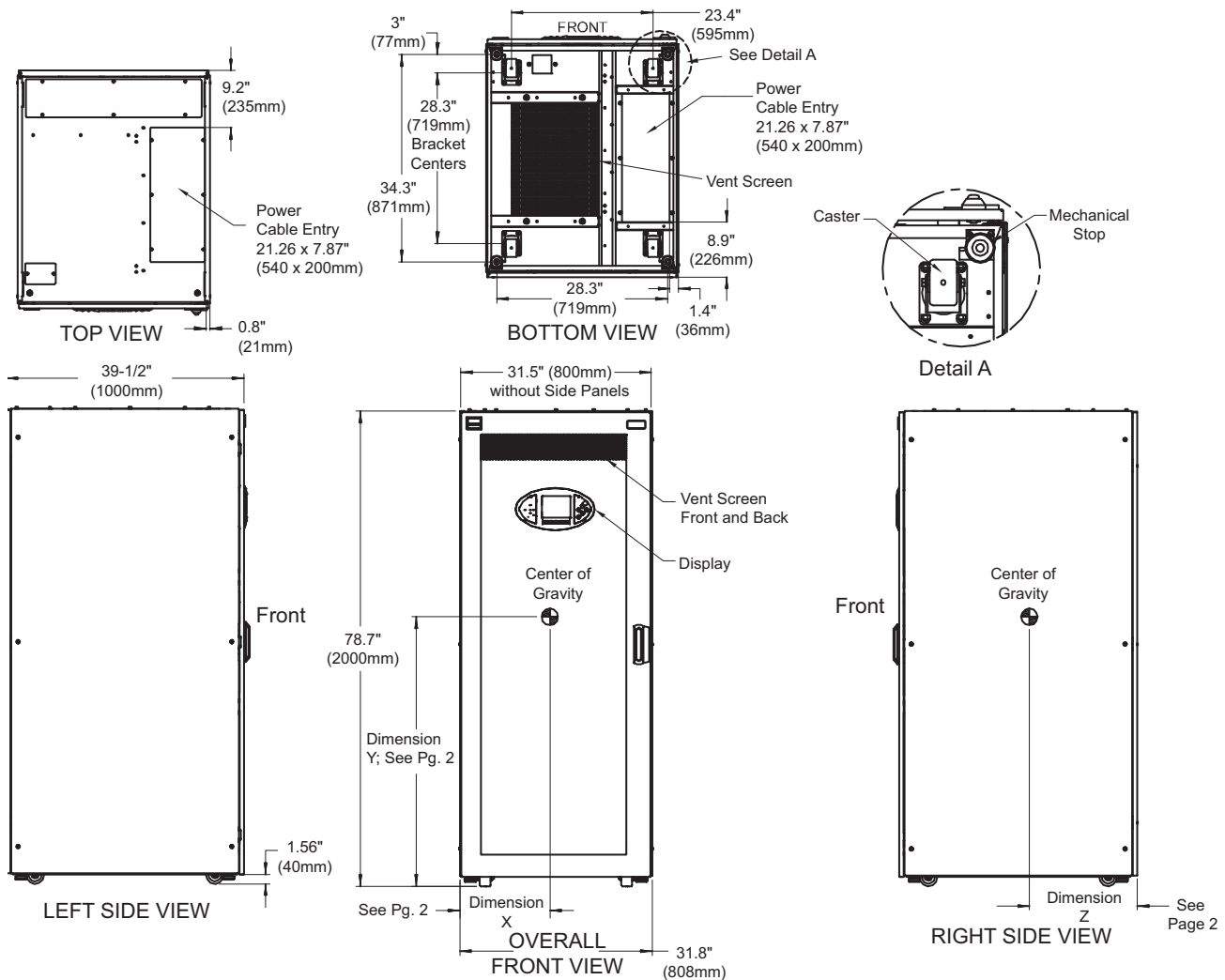

1. All dimensions are in inches (mm).
2. 24" (610) minimum clearance above unit and 12" (305) rear clearance required for air exhaust and 36" (914) front access required for service.
3. Keep cabinet within 15 degrees of vertical.
4. Top and bottom cable entry available through removable access plates. Remove, punch to suit conduit size and replace.
5. Unit bottom is structurally adequate for forklift handling.
6. Control wiring and power wiring must be run in separate conduits.
7. Only copper cables are recommended.
8. All wiring is to be in accordance with national and local electrical codes.
9. See page 2 of 5 drawing: UAM02010B for weight table and centers of gravity for UPS at 208V.
10. See page 3 of 5 drawing: UAM02010C for weight table and centers of gravity for UPS at 480V.
11. See page 4 of 5 drawing: UAM02010D for weight table and centers of gravity for UPS at 600V.
12. See page 5 of 5 drawing: UAM02010E for weight table and centers of gravity for UPS with internal maintenance bypass.

Refer to Tables 11 and 13 for Dimensions X, Y and Z in each Liebert APM model.

UAM2010A
Rev. 2

Figure 50 Liebert APM with top fan kit

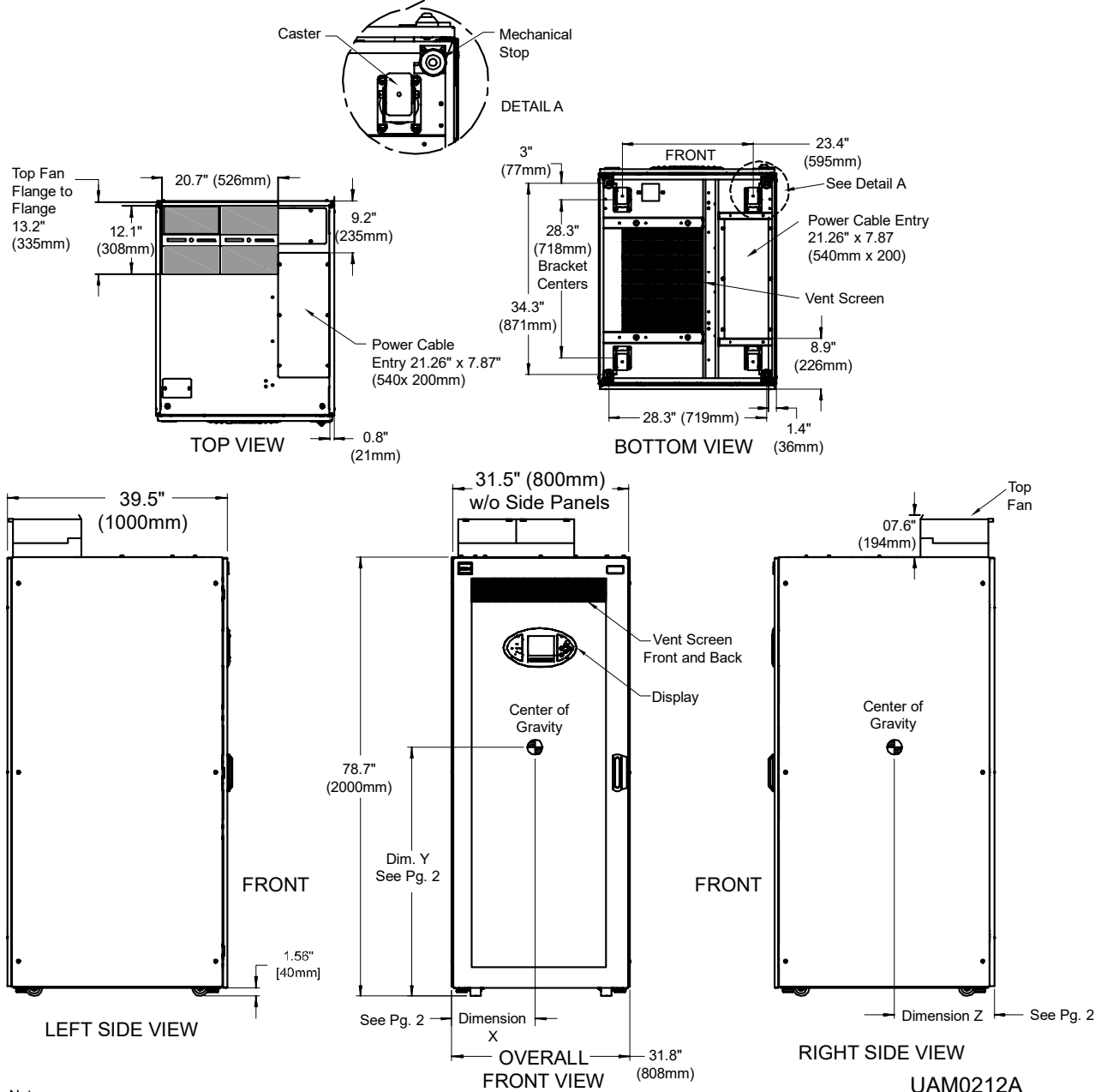

UAM0212A
Pg. 1, Rev. 1

Notes

1. All dimensions are in inches (mm).
2. 24" (610) minimum clearance above unit and 36" (914) front access required for service.
3. Keep cabinet within 15 degrees of vertical.
4. Top and bottom cable entry available through removable access plates. Remove, punch to suit conduit size and replace.
5. Unit bottom is structurally adequate for forklift handling.
6. Control wiring and power wiring must be run in separate conduits.
7. Only copper cables are recommended.
8. All wiring is to be in accordance with national and local electrical codes.
9. See Pg. 2 of 5 drawing: UAM02012B for weight table and centers of gravity for UPS at 208 V.
10. See Pg. 3 of 5 drawing: UAM02012C for weight table and centers of gravity for UPS at 480 V.
11. See Pg. 4 of 5 drawing: UAM02012D for weight table and centers of gravity for UPS at 600 V.
12. See Pg. 5 of 5 drawing: UAM02012E for weight table and centers of gravity for UPS with internal maintenance bypass.

Table 11 Center of gravity and weights for Liebert APM 90 kVA frame

KVA Rating	Center of Gravity			Weight, lb (kg)	
	Dimension X in. (mm)	Dimension Y in. (mm)	Dimension Z in. (mm)	Unit	Shipping
No Internal Options					
15	16.65 (423)	37.64 (956)	18.78 (477)	796 (362)	896 (407)
30	16.18 (411)	38.66 (982)	18.54 (471)	872 (396)	972 (442)
45	15.79 (401)	39.88 (1013)	18.35 (466)	948 (431)	1048 (476)
60	15.47 (393)	41.30 (1049)	18.15 (461)	1024 (465)	1124 (511)
75	15.16 (385)	42.87 (1089)	17.99 (457)	1100 (500)	1200 (545)
90	14.88 (378)	44.57 (1132)	17.83 (453)	1176 (535)	1276 (580)
480V Internal Transformer					
15	13.78 (350)	29.72 (755)	20.43 (519)	1728 (785)	1828 (831)
30	13.66 (347)	30.94 (786)	20.67 (525)	1804 (820)	1904 (865)
45	13.43 (341)	32.32 (821)	20.87 (530)	1880 (855)	1980 (900)
60	13.23 (336)	33.43 (849)	21.06 (535)	1979 (900)	2079 (945)
75	13.15 (334)	34.96 (888)	21.26 (540)	2055 (934)	2155 (980)
90	13.03 (331)	36.26 (921)	21.50 (546)	2131 (969)	2231 (1014)
600V Internal Transformer					
15	14.37 (365)	32.40 (823)	19.80 (503)	1743 (792)	1843 (838)
30	14.25 (362)	33.70 (856)	19.96 (507)	1819 (827)	1919 (872)
45	14.02(356)	35.16 (893)	20.16 (512)	1895 (861)	1995 (907)
60	13.86 (352)	36.73 (933)	20.35 (517)	1989 (904)	2089 (950)
75	13.70 (348)	38.43 (976)	20.59 (523)	2065 (939)	2165 (984)
90	13.50 (343)	40.20 (1021)	20.91 (531)	2141 (973)	2241 (1019)
Internal Maintenance Bypass					
15	16.02 (407)	43.94 (1116)	21.89 (556)	985 (448)	1085 (493)
30	15.55 (395)	44.96 (1142)	22.13 (562)	1061 (482)	1161 (528)
45	15.16 (385)	46.22 (1174)	22.32 (567)	1137 (517)	1237 (562)
60	14.80 (376)	47.64 (1210)	22.52 (572)	1213 (551)	1313 (597)
75	14.57 (370)	49.21 (1250)	22.68 (576)	1289 (586)	1389 (631)
90	14.33 (364)	50.91 (1293)	22.80 (579)	1365 (620)	1465 (666)

Table 12 Center of gravity and weights for Liebert APM 90 kVA frame with top fan option

KVA Rating	Center of Gravity			Weight, lb (kg)	
	Dimension X in. (mm)	Dimension Y in. (mm)	Dimension Z in. (mm)	Unit	Shipping
Top Fan Option Only					
15	17.99 (457)	37.83 (961)	18.70 (475)	827 (376)	927 (421)
30	16.34 (415)	38.90 (988)	18.43 (468)	903 (410)	1003 (456)
45	15.94 (405)	40.08 (1018)	18.23 (463)	979 (445)	1097 (498)
60	15.63 (397)	41.54 (1055)	18.03 (458)	1055 (480)	1155 (525)
75	15.31 (389)	43.11 (1095)	17.91 (455)	1131 (514)	1231 (560)
90	15.04 (382)	44.72 (1136)	17.72 (450)	1027 (549)	1127 (512)
480V Internal Transformer					
15	13.94 (354)	29.92 (760)	20.31(516)	1759 (800)	1859 (845)
30	13.82 (351)	31.14(791)	20.55 (522)	1835 (834)	1935 (880)
45	13.58 (345)	32.52 (826)	20.79 (528)	1911 (869)	2011 (914)
60	13.39 (340)	33.66 (855)	20.94 (532)	2010 (914)	2110 (959)
75	13.27 (337)	35.16 (893)	21.14 (537)	2086 (948)	2186 (994)
90	13.19(335)	36.46 (926)	21.38(543)	2162 (983)	2262 (1028)
600V Internal Transformer					
15	14.53 (369)	32.60 (828)	19.69 (500)	1774 (806)	1874 (852)
30	14.41 (366)	33.86 (860)	19.84 (504)	1850 (841)	1950 (887)
45	14.17 (360)	35.35 (898)	20.04 (509)	1926 (875)	2026 (921)
60	14.02 (356)	36.93 (938)	20.24 (514)	2020 (918)	2120 (964)
75	13.86 (352)	38.58 (980)	20.47 (520)	2096 (953)	2196 (998)
90	13.58 (345)	40.39 (1026)	20.79 (528)	2172 (987)	2272 (1033)
Internal Maintenance Bypass					
15	16.18 (411)	44.13 (1121)	21.77 (553)	1016 (462)	1116 (507)
30	15.67 (398)	45.20 (1148)	21.97 (558)	1092 (496)	1192 (542)
45	15.31 (389)	46.38 (1178)	22.20 (564)	1168 (531)	1268 (576)
60	14.96 (380)	47.83 (1215)	22.36 (568)	1244 (565)	1344 (611)
75	14.72 (374)	49.41 (1255)	22.56 (573)	1320 (600)	1420 (645)
90	14.49 (368)	51.02 (1296)	22.64 (575)	1396 (635)	1496 (680)

Table 13 Center of gravity and weights for Liebert APM 45 kVA frame

kVA Rating	Center of Gravity			Weight, lb (kg)	
	Dimension X in. (mm)	Dimension Y in. (mm)	Dimension Z in. (mm)	Unit	Shipping
12HX100 Batteries					
15	14.29 (363)	31.50 (800)	21.30 (541)	1922 (874)	2022 (919)
30	13.94 (354)	33.46 (850)	21.59 (548.4)	1998 (908)	2098 (954)
45	13.62 (346)	35.04 (890)	21.73 (552)	2074 (943)	2174 (988)
12HX150 Batteries					
15	14.25 (362)	30.91 (785)	21.54 (547)	2114 (961)	2214 (1006)
30	13.78 (350)	32.87 (835)	21.81 (554)	2190 (995)	2290 (1041)
45	13.39 (340)	34.72 (882)	22.05 (560)	2260 (1030)	2360 (1073)

Table 14 Center of gravity and weights for Liebert APM 45 kVA frame with top fan option

kVA Rating	Center of Gravity			Weight, lb (kg)	
	Dimension X in. (mm)	Dimension Y in. (mm)	Dimension Z in. (mm)	Unit	Shipping
12HX100 Batteries					
15	14.45 (367)	31.69 (805)	21.18 (538)	1953 (888)	2053 (933)
30	14.09 (358)	33.66 (855)	22.83 (580)	2029 (922)	2129 (968)
45	13.78 (350)	35.24 (895)	21.61 (549)	2105 (957)	2205 (1002)
12HX150 Batteries					
15	14.41 (366)	31.10 (790)	21.42 (544)	2145 (975)	2245 (1020)
30	13.94 (354)	33.07 (840)	21.65 (550)	2221 (1010)	2321 (1055)
45	13.58 (345)	34.92 (887)	21.93 (557)	2297 (1044)	2397 (1090)

Figure 51 UPS main components—typical unit

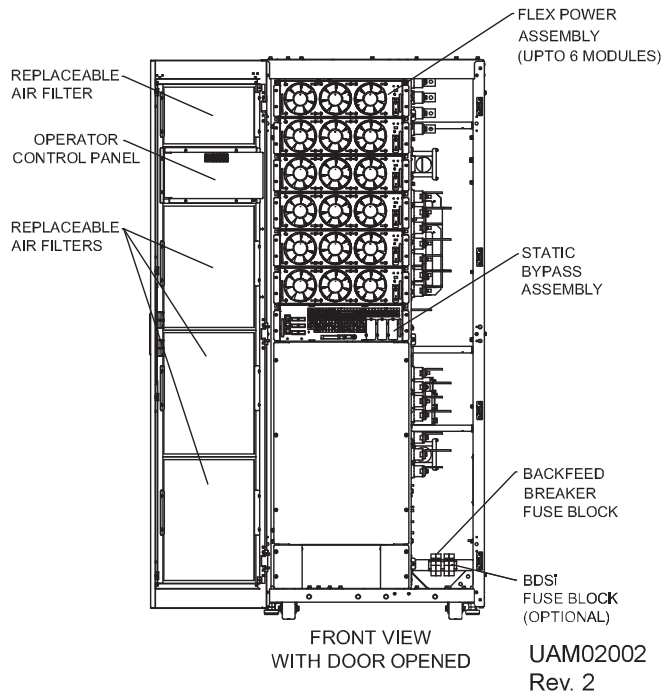
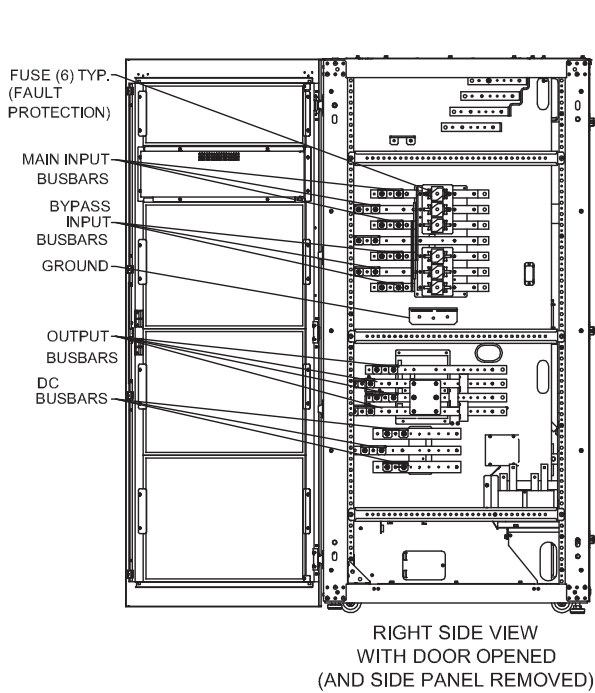
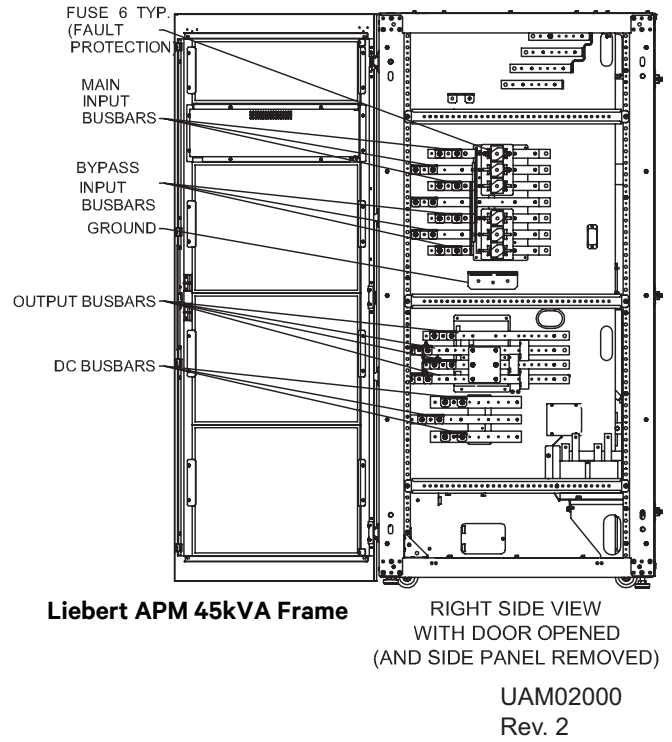
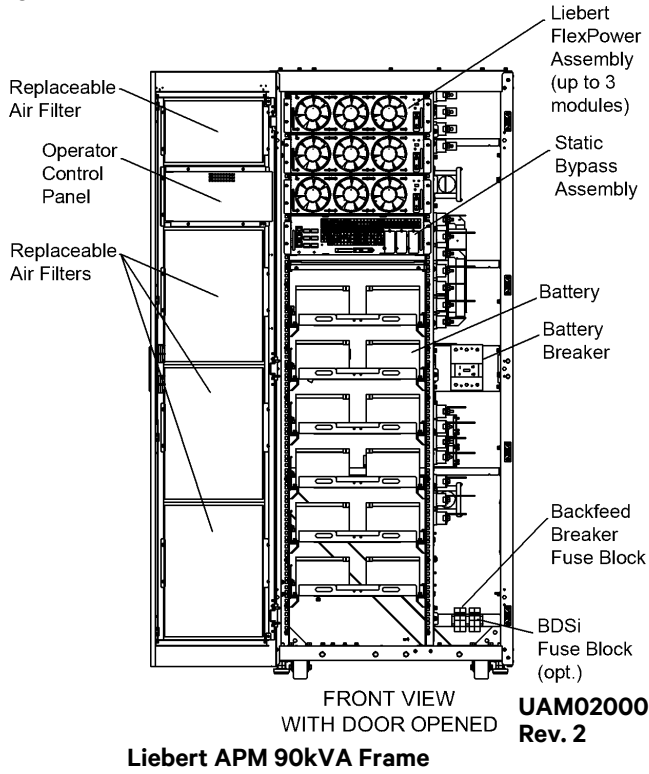

Figure 52 UPS cable connections—45kVA and 90kVA frames

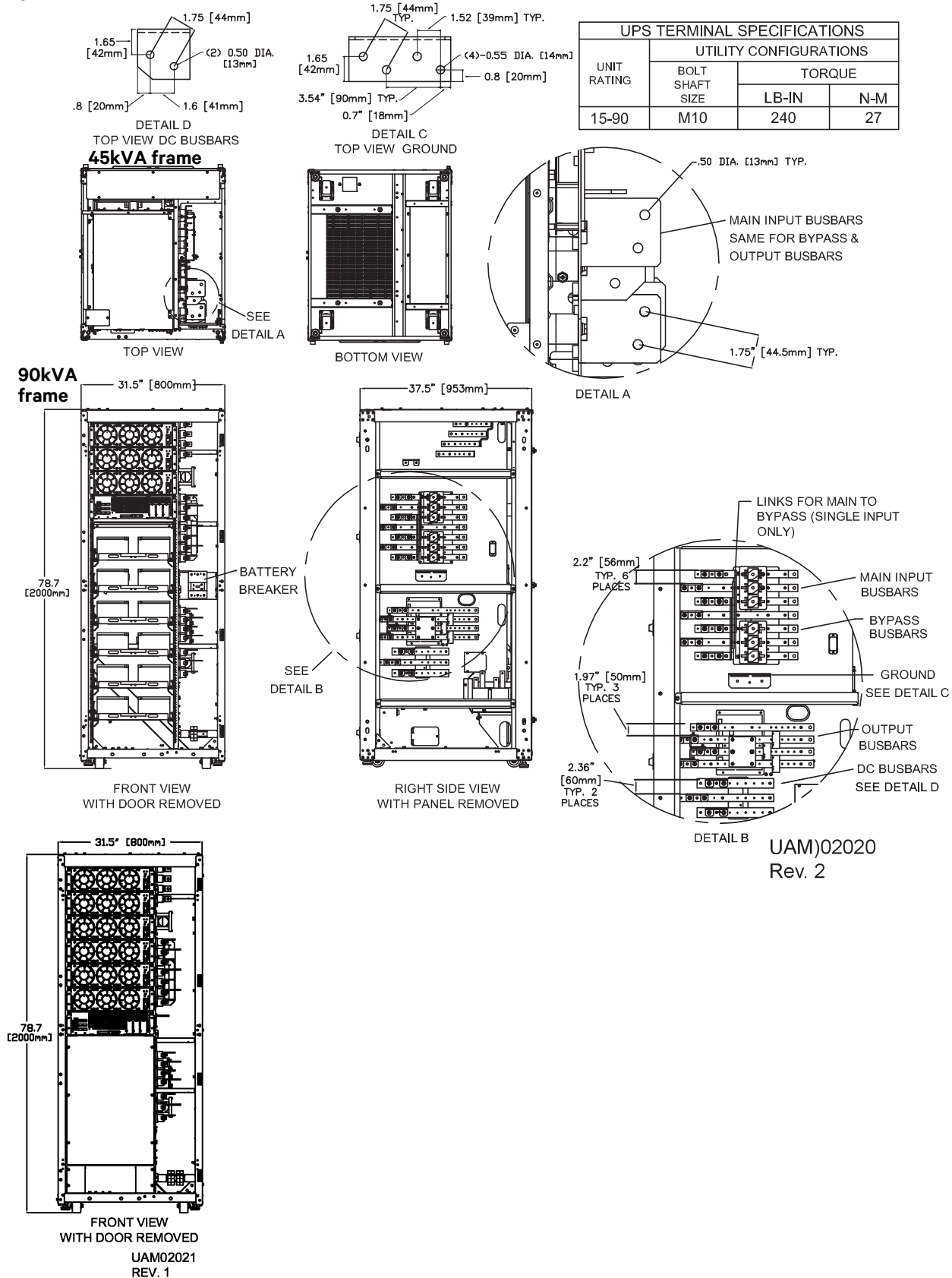
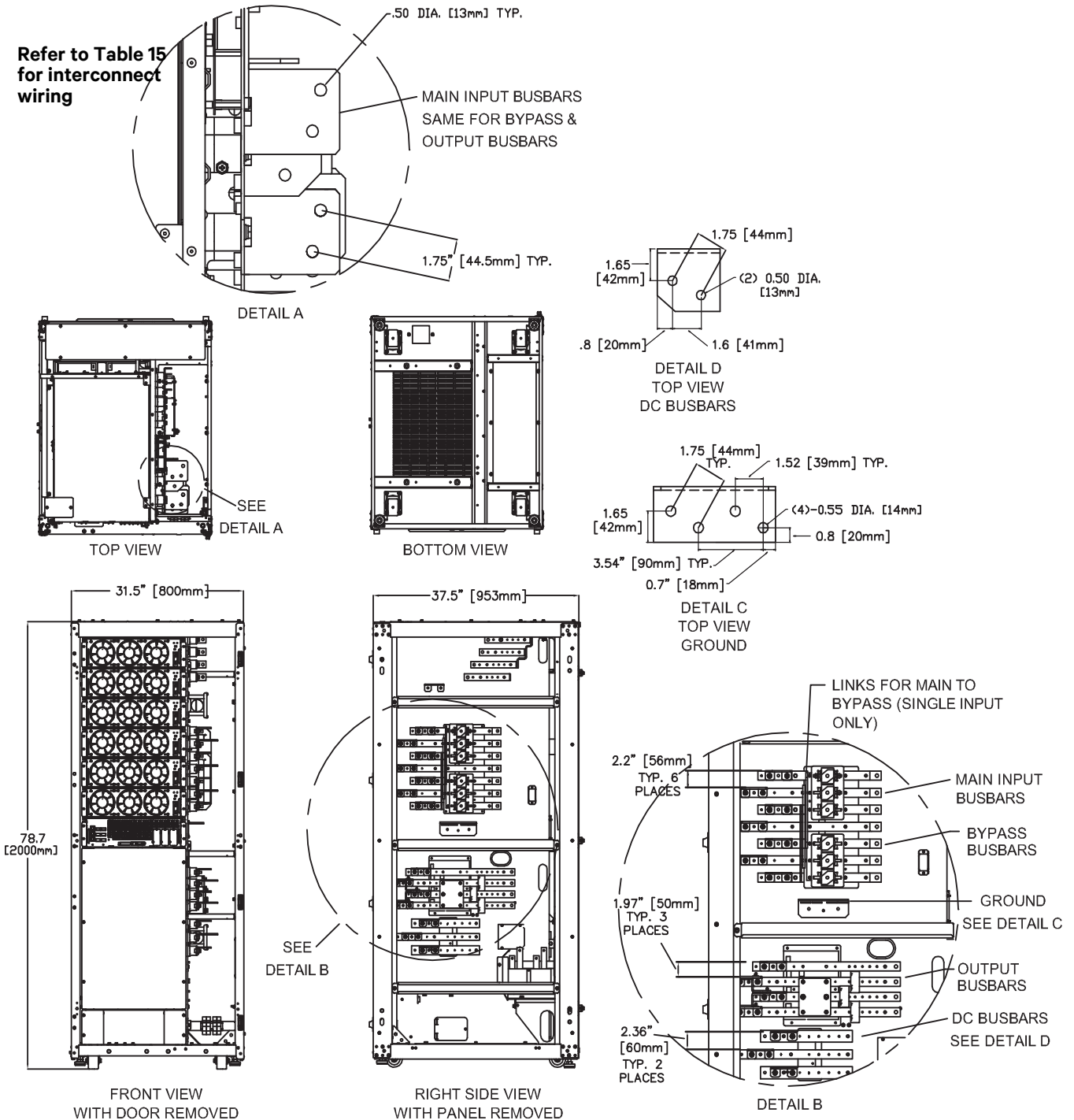

Figure 53 Battery cabinet connection to UPS



NOTES

1. Dimensions are in inches [mm].
2. Control wiring and power wiring must be run in separate conduits.
3. Vertiv recommends using only copper cables.
4. All wiring must be in accordance with national and local electrical codes.

UAM0201
 Rev. 3

Figure 54 Battery cabinet connection to UPS (continued)

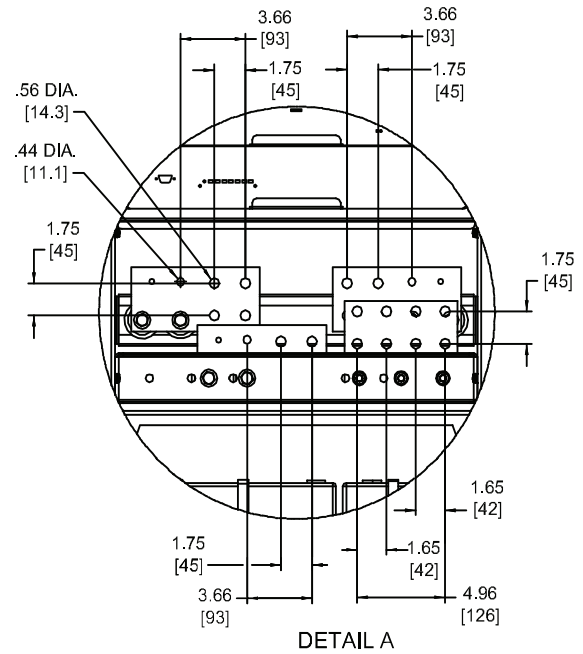
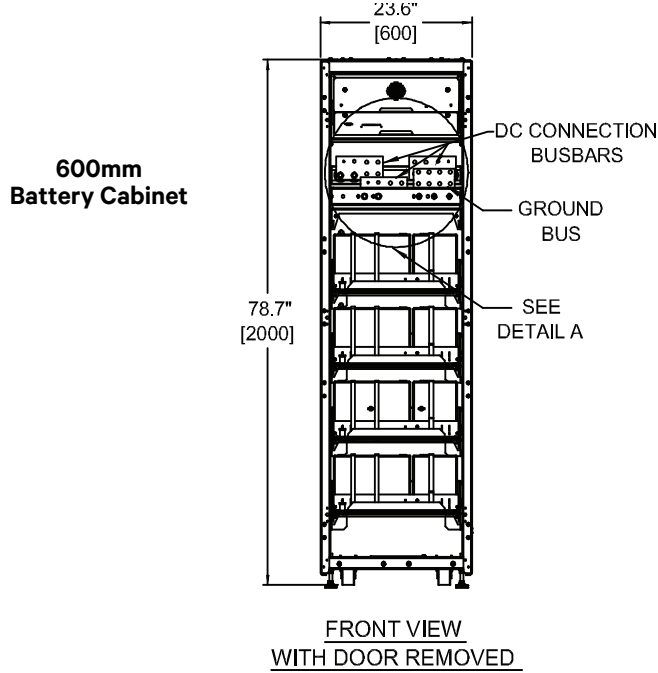

UAM05020
Rev. 1

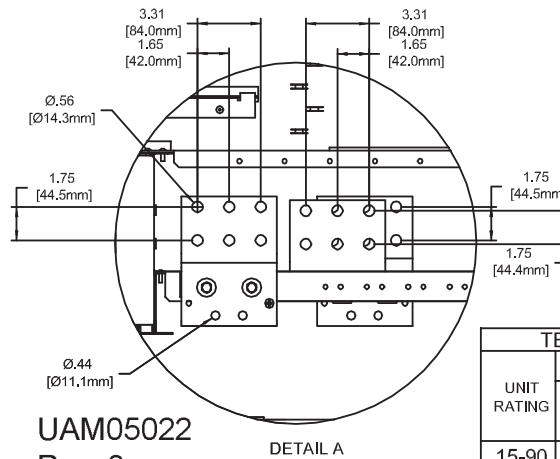
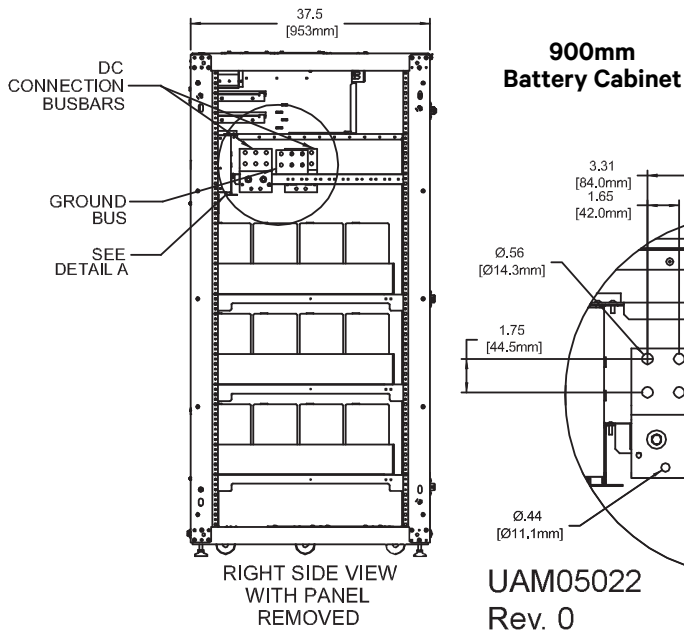

UAM05022
Rev. 0

TERMINAL SPECIFICATIONS			
UNIT RATING	UTILITY CONFIGURATIONS		
	BOLT SHAFT SIZE	TORQUE	
		LB-IN	N-M
15-90	M10	240	27

Table 15 Interconnect wiring for Liebert APM to battery cabinet

Run	From	To	Conductors
A	UPS Battery Busbar	External Battery Cabinet Busbar	Positive, DC Neutral, Negative
B	Battery Cabinet Terminal Block TB1	UPS Static Bypass Assembly J4 and J8	Battery Breaker Shunt and Aux Contacts

See **Figure 40** for additional details.



NOTE

Wiring is supplied when the UPS and external battery cabinet are ordered as a system.

Figure 55 Battery cabinet outline drawing, weights and center of gravity, 600mm cabinet

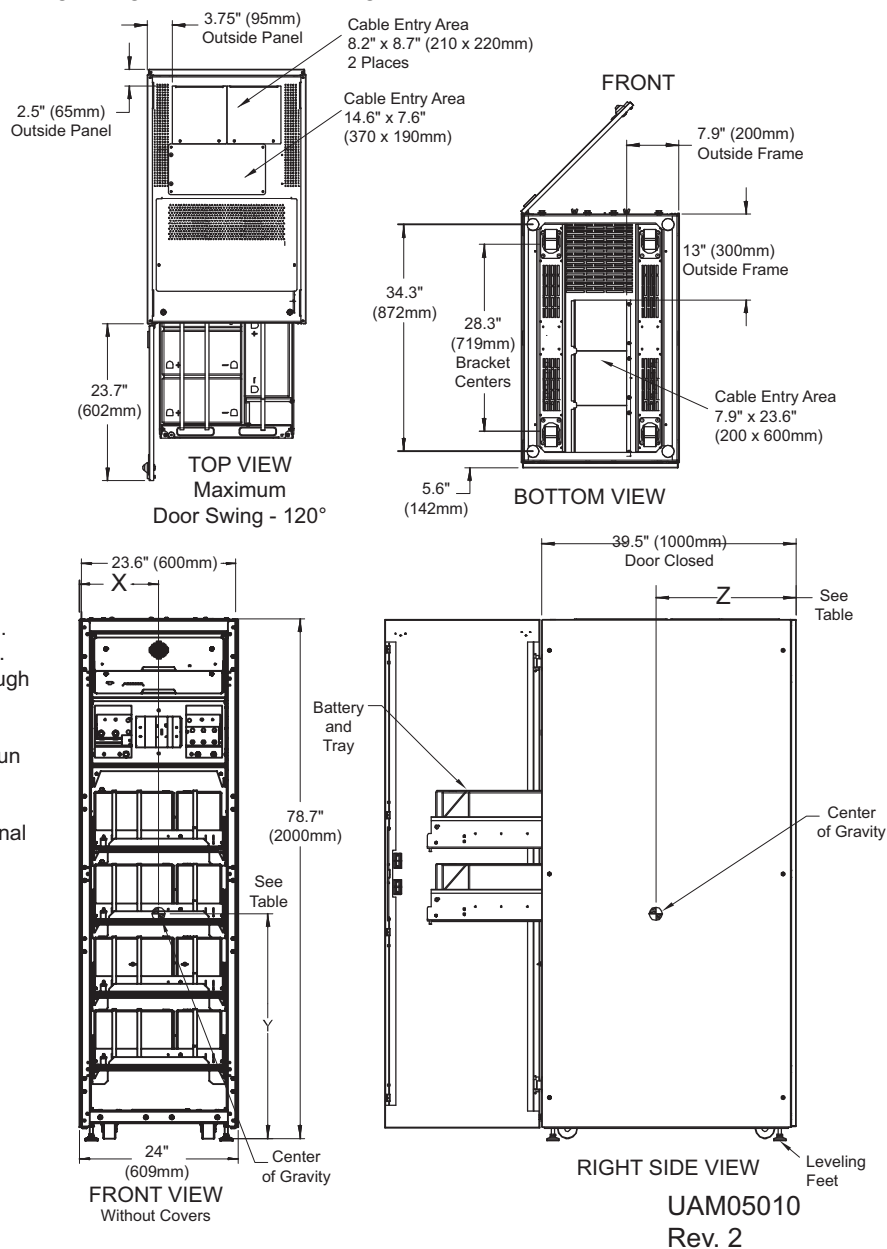

1. All dimensions are in inches (mm).
2. 24" (610) minimum clearance above unit; 36" (914) front access required for service.
3. Keep cabinet within 15 degrees of vertical.
4. Top and bottom cable entry available through removable access plates. Remove, punch to suit conduit size and replace.
5. Control wiring and power wiring must be run in separate conduits.
6. Only copper cables are recommended.
7. All wiring is to be in accordance with national and local electrical codes.

Table 16 Battery cabinet, center of gravity and weights

Battery Model	Center of gravity			Battery Weights * lb (kg)
	X in (mm)	Y in (mm)	Z in (mm)	
12HX150-FR	300	580	900	1490 (677)
12HX205-FR	300	570	890	1755 (798)
12HX300-FR	290	550	870	2213 (1006)
12HX330-FR	280	550	860	2477 (1126)

* For shipping weight, add 100 lb. (45 kg).
Source: UAM05010, Rev. 2

Figure 56 Battery cabinet outline drawing, weights and center of gravity 900mm cabinet

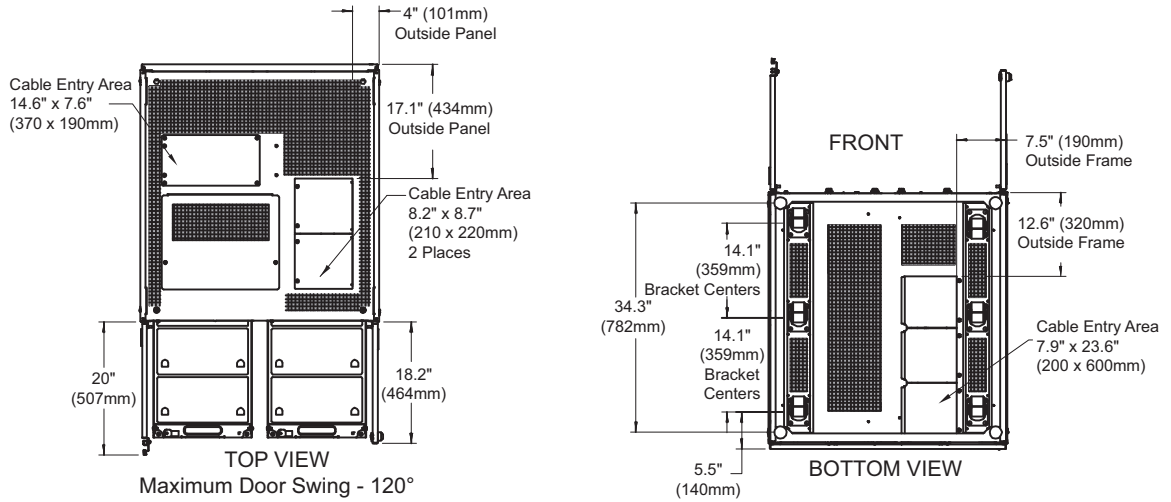

Center of Gravity, In. (mm)			
Battery Type	X	Y	Z
12HX400-FR	17.3 (440)	35 (890)	20 (510)
12HX505-FR	17.3 (440)	33 (840)	20.9 (530)
12HX540-FR	17.3 (440)	33 (840)	20.9 (530)

Approximate Weights *	
Battery Type	Weight, Lb. (kg)
12HX400-FR	2693 (1224)
12HX505-FR	3245 (1475)
12HX540-FR	3345 (1520)

* For shipping weights, add 100 lb. (45 kg)

1. All dimensions are in inches (mm).
2. 24" (610) minimum clearance above unit; 36" (914) front access required for service.
3. Keep cabinet within 15 degrees of vertical.
4. Top and bottom cable entry available through removable access plates. Remove, punch to suit conduit size and replace.
5. Control wiring and power wiring must be run in separate conduits.
6. Only copper cables are recommended.
7. All wiring is to be in accordance with national and local electrical codes.

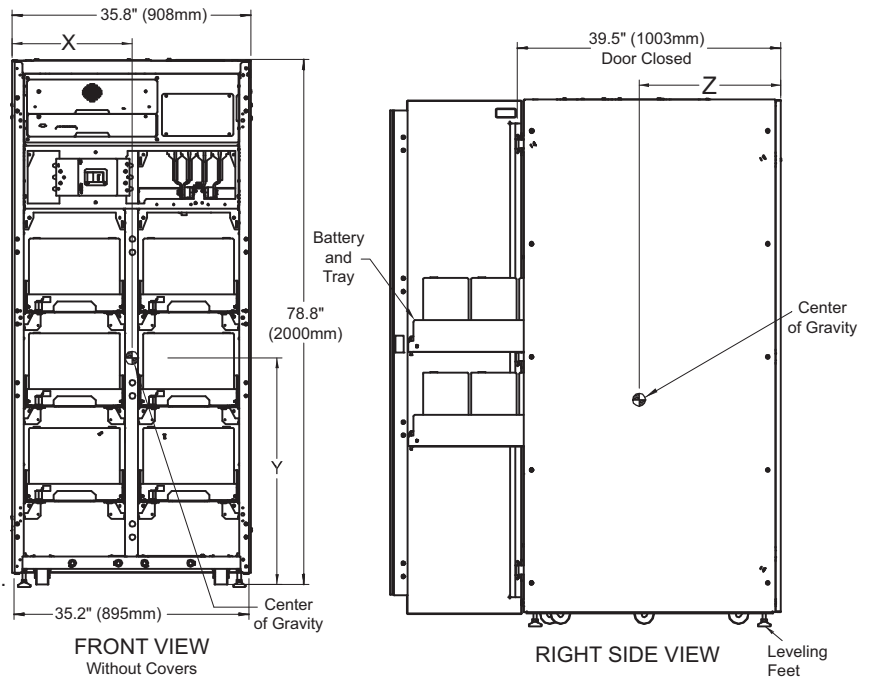

UAM05012
Rev. 1

Figure 57 Outline drawing, Liebert BDC for Liebert APM, 15-45kVA

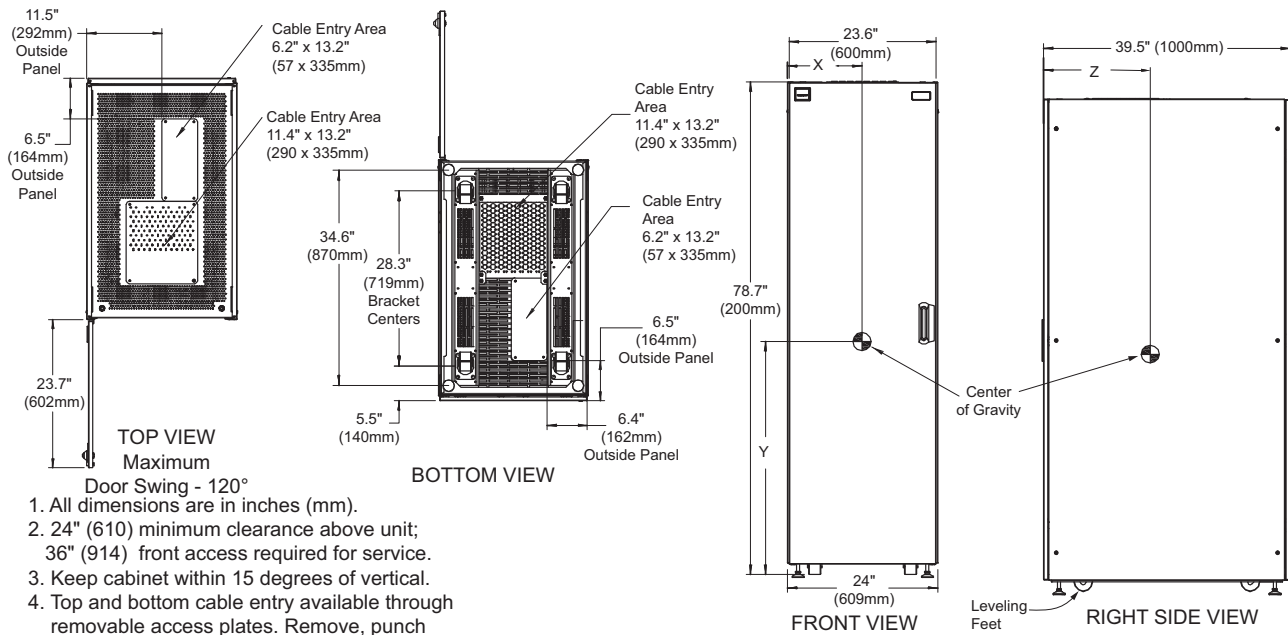

1. All dimensions are in inches (mm).
2. 24" (610) minimum clearance above unit;
36" (914) front access required for service.
3. Keep cabinet within 15 degrees of vertical.
4. Top and bottom cable entry available through removable access plates. Remove, punch to suit conduit size and replace.
5. Control wiring and power wiring must be run in separate conduits.
6. Only copper cables are recommended.
7. All wiring is to be in accordance with national and local electrical codes.

UAM06008
Rev. 5

Liebert BDC with Distribution Type	Dimension, in. (mm)			Weight, * lb (kg)
	X	Y	Z	
Without Panelboard	11.8" (300)	39.4" (1000)	14.9" (379)	525 (239)
With Panelboard	11.8" (300)	39.4" (1000)	14.9" (379)	625 (284)

* Shipping weight, add 100 lb. (45kg)

Figure 58 Outline drawing, Liebert BDC for Liebert APM, 15-90kVA

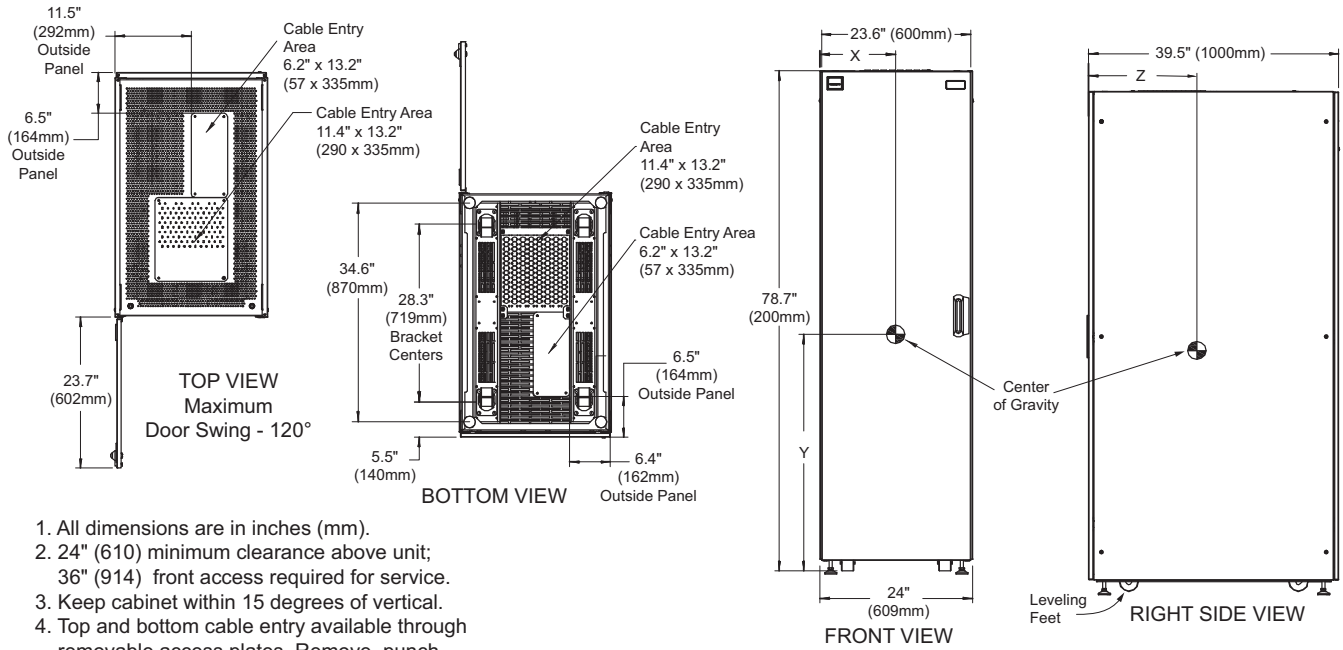

1. All dimensions are in inches (mm).
2. 24" (610) minimum clearance above unit; 36" (914) front access required for service.
3. Keep cabinet within 15 degrees of vertical.
4. Top and bottom cable entry available through removable access plates. Remove, punch to suit conduit size and replace.
5. Control wiring and power wiring must be run in separate conduits.
6. Only copper cables are recommended.
7. All wiring is to be in accordance with national and local electrical codes.

UAM06010
Rev. 5

Liebert BDC with Distribution Type	Dimension, in. (mm)			Weight,* lb (kg)
	X	Y	Z	
No Distribution	11.8" (300)	39.4" (1000)	14.9" (379)	550 (250)
With 2-225A Subfeed Breakers	11.8" (300)	39.4" (1000)	14.9" (379)	660 (300)
With 400A Panelboard	11.8" (300)	39.4" (1000)	14.9" (379)	660 (300)

* Shipping weight, add 100 lb. (45kg)

Figure 59 Liebert BDC connection to UPS

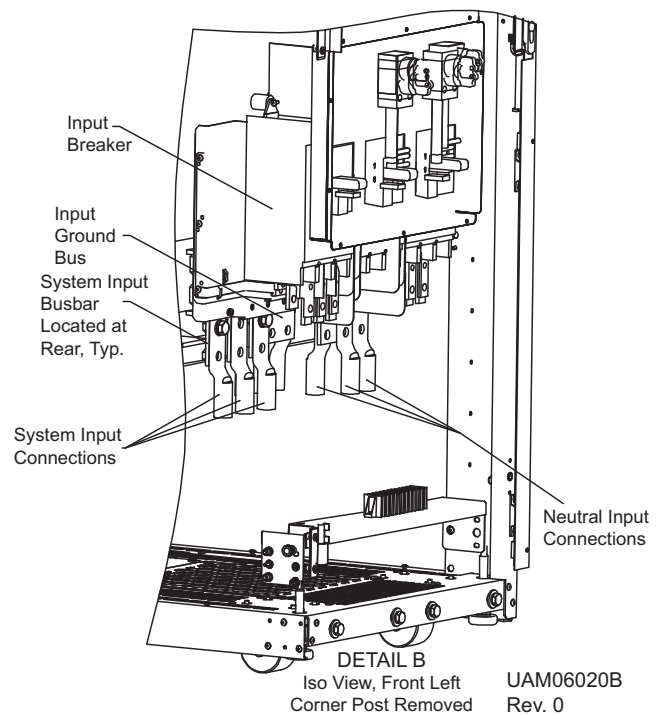
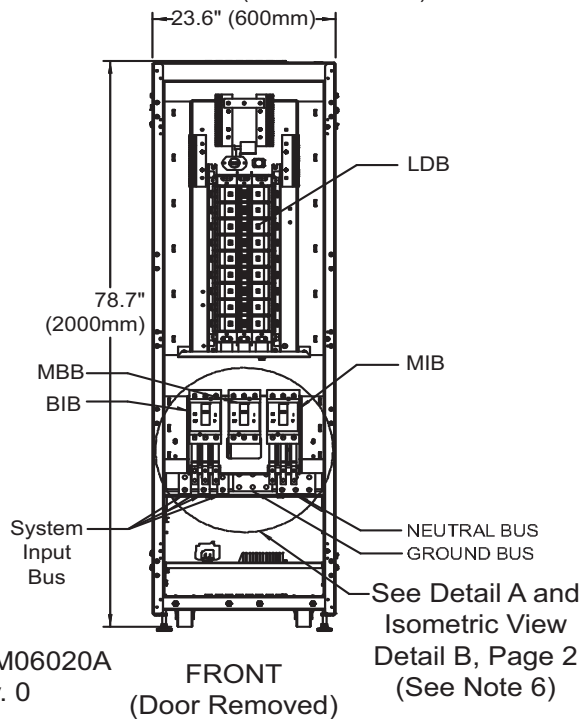
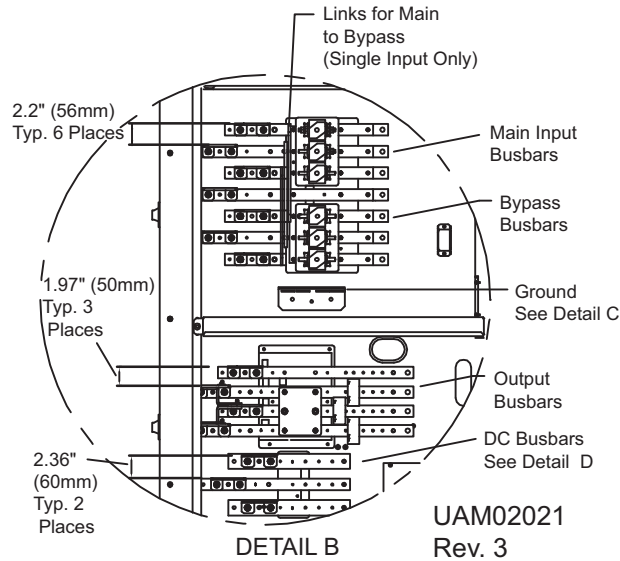
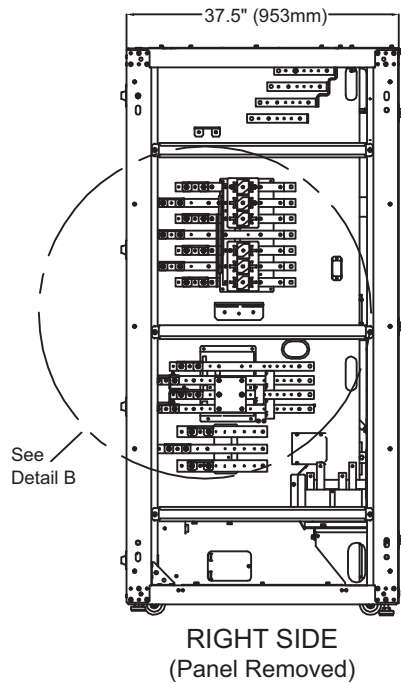

NOTES

1. All Vertiv-supplied cable must be repositioned prior to and while the cabinets are being placed in their final installed location.
2. All interconnection hardware supplied by Vertiv.
3. AC connections must be made to the UPS module before attaching Liebert BDC to UPS module.
4. All cabling will be field-supplied when a Liebert BDC is configured as a stand-alone cabinet.
5. Liebert BDCs must attach to the right side only of the Liebert APM.
6. Refer to the individual drawing of each piece of equipment for additional details.

Table 17 Interconnect wiring for Liebert APM to Liebert BDC

Run	From	To	Conductors
A	Utility AC source	BDC System Input Bus	Phase A, B, C
B	Utility AC Source	BDC System Input Bus	Neutral
C	BDC Bypass Isolation Breaker	UPS Main Input	Phase A, B, C
D	BDC Bypass Isolation Breaker	UPS Main Input	Neutral
E	UPS Output	MBC Maintenance Isolation Breaker	Phase A, B, C
F	UPS Output	MBC Maintenance Isolation Breaker	Neutral
G	BDC Panelboard	Load AC Connection	Phase A, B, C
H	BDC Panelboard	Load AC Connection	Neutral
I	Utility AC Source	All Ground Connections	Ground
J	BDC Terminal Block TB1	UPS Static Bypass Module J5 and J12	Wiring for KO on MBC

See **Figure 45** and **Table 10** for additional details.



NOTE

Wiring is supplied when the UPS and Liebert BDC are ordered as a system.

Table 18 Spring washer torque application

Hardware	Two Belleville Washers
M10 (3/8")	240 lb-in. (27 N-m)

Figure 60 Acceptable hardware configuration for torque application

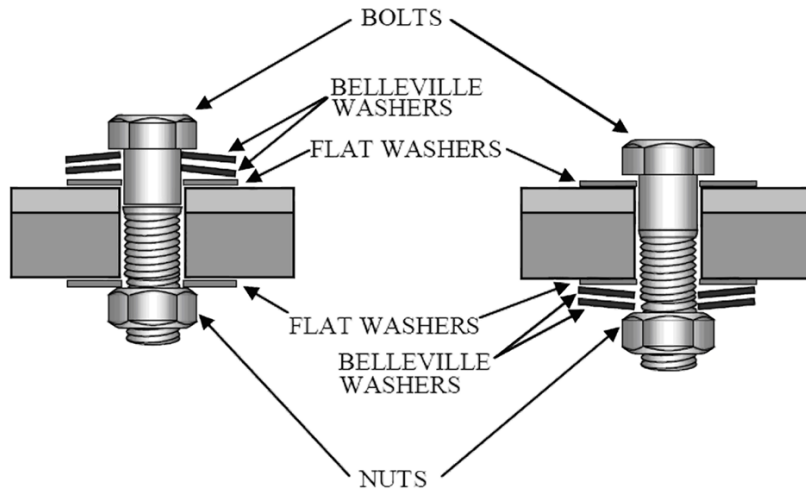
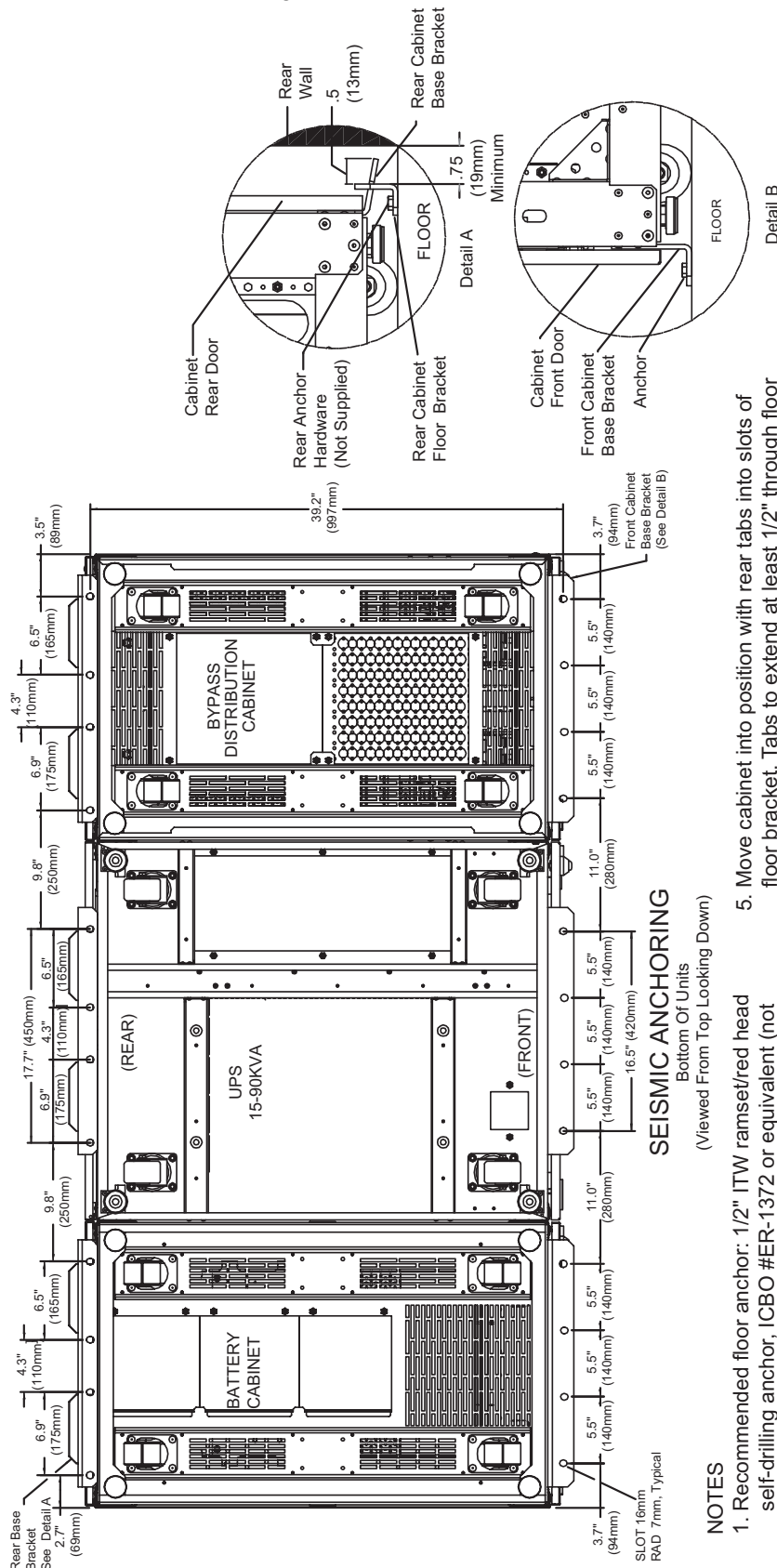

Figure 61 Seismic mounting bracket details



SEISMIC ANCHORING
Bottom Of Units
(Viewed From Top Looking Down)

1. Recommended floor anchor: 1/2" ITW ramset/red head self-drilling anchor, ICBO #ER-1372 or equivalent (not supplied). Follow manufacturer's instructions.
2. Position rear floor brackets on floor at least .75" from rear wall. Mark location and drill holes (Detail A) to a minimum depth of 4.12" (104.6mm) into the concrete.
3. Install rear cabinet base bracket (Detail A) to existing holes on underside of unit with tabs facing rear wall. Use supplied hardware and torque to 365 lb-inch (41.2 Nm). Loosen leveling bolt locking nut and tighten after bracket is secured.
4. Install front cabinet base bracket (Detail B) to existing holes on underside of unit with bent flange facing front. Use supplied hardware and torque to 365 lb-inch (41.2 Nm). Loosen leveling bolt locking nut and tighten after bracket is secured.
5. Move cabinet into position with rear tabs into slots of floor bracket. Tabs to extend at least 1/2" through floor bracket (Detail A). Then attach front floor brackets to front cabinet base bracket but do not fully tighten hardware.
6. Mark hole locations and remove brackets. Drill and install floor brackets. Unit door can be removed for better access. Reinstall front floor brackets to front cabinet brackets with supplied hardware and torque to 235 lb-in (26.5 Nm).
7. After all cabinets are moved into place and secured to the floor, multiple cabinet configurations are then bolted together.
8. If side walls are present, 1.0" (25.4mm) minimum distance from either side wall is required.

UAM08020
Rev. 2

8.0 LIEBERT INTELLISLOT™ INSTALLATION

8.1 Liebert IntelliSlot Communication

The Liebert APM has three Liebert IntelliSlot ports to allow installation of optional communication cards. Liebert IntelliSlot cards communicate via Liebert’s proprietary Velocity protocol to cards that translate the information into such protocols as SNMP and Modbus. Other cards provide dry contact signals for external signaling of operating status.

The Liebert IntelliSlot communication ports may be installed or removed while the Liebert APM is operating.

8.2 Liebert IntelliSlot Web Card—SNMP/HTTP Network Interface Card

This network interface card provides all real-time data and status information as SNMPv1 traps for connection to a 10/100-baseT Ethernet connection. The same card also will transmit the same status information and all measured parameters for display via a Web browser. The Liebert IntelliSlot bays are on the right side of the control module and labeled as IntelliSlot1, IntelliSlot2 and IntelliSlot3.

Table 19 Liebert APM communication options

Port Type and Location	Labeled ID Name of Port	Monitoring Devices Supported
Left Liebert IntelliSlot	IntelliSlot 1	IS-Relay
		IS-485EXI
Center Liebert IntelliSlot	IntelliSlot 2	IS-Relay
		IS-Unity-DP
		IS-Unity-LIFE
Right Liebert IntelliSlot	IntelliSlot 3	IS-Relay
		IS-Unity-DP
		IS-Unity-LIFE
		IS-485EXI

8.2.1 Liebert IntelliSlot™ Unity Cards—IS-UNITY-LIFE, IS-UNITY-S, IS-UNITY-DP

- IS-UNITY-LIFE (Included): Offers a web interface to manage and configure the Vertiv Life.net and Vertiv proprietary protocols for use with the Vertiv Life Station™, Liebert Nform® and Vertiv® Trellis™.
- IS-UNITY-DP: Offers a web interface to monitor and configure the Life.net and Vertiv proprietary protocols for use with the Vertiv Life Station, Liebert Nform and Vertiv Trellis. It allows selection and configuration of two of the available third-party protocols—SNMP, Modbus or BACnet—for operation with building management systems.
- Liebert IntelliSlot® Dry Contact Card (IS-RELAY): Provides dry contact alarm information, including: On Battery, On Bypass, Low Battery, Summary Alarm, UPS Fault and On UPS signals for communication to a remote monitoring system.
- IS-485EXI: The Liebert IntelliSlot 485 EXI Card provides connection to a Liebert SiteLink-E™ allowing Liebert SiteScan® Web monitoring and control of your Liebert equipment.

8.3 Liebert IntelliSlot Card Web Interface

The IS-Unity-Life and IS-Unity-DP IntelliSlot cards offer a Web interface, yielding a wide variety of status and summary information through an Ethernet connection. Liebert’s IS-Unity-DP also provides e-mail and text notification.

Figure 62 Liebert IntelliSlot Web card display

monitor
control
configure
data/logs
support

Summary: Updated: May 26, 2010 10:28:57AM

Device Status:
unknown

- Summary
- Active Events
- Input
- Bypass
- Battery
- Output
- System Status
- System Events
- System Configuraton

Bypass				
	∅A	∅B	∅C	Units
L-N	0	0	0	VAC
Frequency	0.00			Hz

Input				
	∅A	∅B	∅C	Units
L-N	0	0	0	VAC
Frequency	0.00			Hz

Output				
	∅A	∅B	∅C	Units
L-N	0	0	0	VAC
System	0.00	0.00	0.00	A AC
System	0	0	0	%
System	0			kVA
System	0			kW
Frequency	0.00			Hz

Battery				
Voltage	0	VDC	Current	0.00 A DC
Temperature	32	°F	Time Remaining	0 min

Legend

Normal

Absent

Active Events: Updated: May 26, 2010 10:28:57AM

No Active Events

8.4 Liebert IntelliSlot™ Relay Card

The Liebert IntelliSlot Relay card (IS-RELAY) provides voltage-free contact closures for remote monitoring of alarm conditions.

Delivering On Battery, On Bypass, Low Battery, Summary Alarm, UPS Fault and On UPS signals, the easy-to-install card integrates with AS/400 computers (additional cable required) and other relay contact monitoring systems.

The relay card is rated for 24 VAC/DC at 1A. and supported in any of the three Liebert IntelliSlot bays on the Liebert APM.

8.4.1 Liebert IntelliSlot Relay Card Pin Configuration

The card has two terminals blocks, TB1 (green, numbered 1-9) and TB2 (black, 10-18), as shown in **Figure 63**.

Figure 63 Pin location and numbering

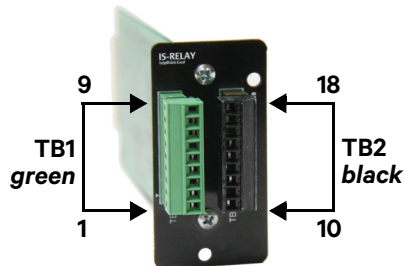

Refer to your Liebert product user manual for the pin configuration for the terminal blocks.

Table 20 Relay card pin configuration

Pin	Function	Operation
1	Common - Low Battery	—
2	Low Battery	Closed if Low Battery point occurs.
3	Low Battery	Closed if battery is OK
4	Common - UPS Fault	—
5	UPS Fault	Closed if UPS fault occurs
6	UPS Fault	Closed if no UPS failure
7	Common - On Battery	—
8	On Battery	Closed if On Battery power (Utility failure)
9	On Battery	Closed if not On Battery power (Utility OK)
10	Not Used	—
11	Not Used	—
12	Not Used	—
13	Summary Alarm*	Closed if no alarm conditions are present
14	Summary Alarm*	Closed if Summary Alarm occurs
15	Common - Summary Alarm*	—
16	On UPS	Closed if On UPS (inverter) power
17	On Bypass	Closed if On Bypass
18	Common - On Bypass	—

8.4.2 Liebert IntelliSlot™ Relay Card Jumper Setup

The Liebert IntelliSlot Relay Card has five jumpers, P3 through P7, as shown in **Figure 64**. Each jumper connects two pins.

Figure 64 Jumper location and numbering

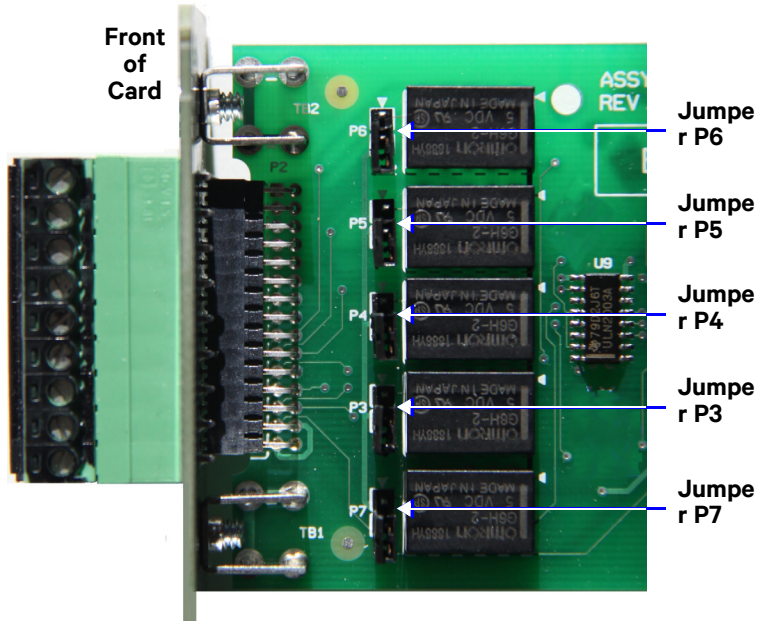

By default all five jumpers have shunts installed. The two pins are shunted together to provide the functions shown in **Table 21**, allowing relay commons to be tied together.

The jumpers should be removed if there is any external voltage source that may intentionally or inadvertently be connected to the relay.

Removing the shunt from any two pins breaks the connection between the relay commons so they are not tied together.

Table 21 Jumper connections

Jumper	Relay
P6	On Battery
P5	UPS Fault
P4	Low Battery
P3	On Bypass
P7	Summary Alarm



NOTE

Refer to the Liebert IntelliSlot Relay Card manual, SL-23211 for additional details. the document is available at the Vertiv Web site, www.vertiv.com

8.6 Battery Temperature Compensation

For a UPS with external batteries, an optional battery temperature interface optimizes the external battery management by connecting up to four external temperature sensors from the battery cabinets to a control unit inside the UPS.

Figure 66 Multi-temperature sensors

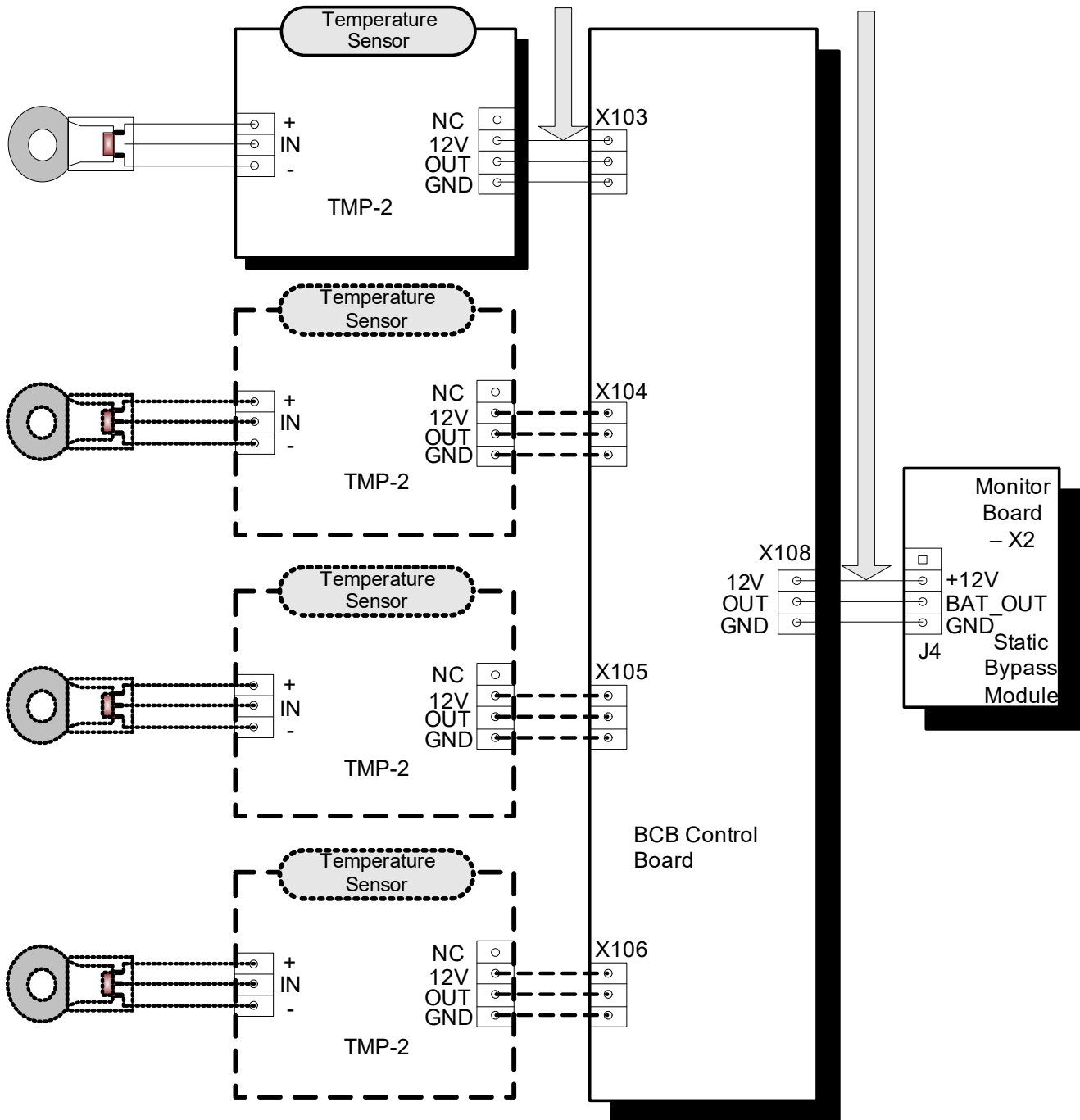

9.0 OPERATOR CONTROL AND DISPLAY PANEL

9.1 Operator Control Panel

The control panel and LCD on the front of the Liebert APM lets the operator:

- Turn the UPS On or Off.
- Transfer into the various operating modes.
- Silence alarms.
- Check the status of the UPS and its batteries, including all measured parameters, events and alarms.

The main areas of the control panel are shown below in **Figure 67** and explained in **Table 22**.

- Mimic Display - view the status of the Liebert APM in single-line diagram format—indicators show status by changing color when ON, flashing or OFF
- Liquid Crystal Display (LCD) and Navigation keys - view status and operational data from the Liebert APM in tabular format
- Control buttons - turn the Liebert APM on or off, silence alarms

Figure 67 Overview of control panel



Table 22 Descriptions of UPS operator control and display panel

Mimic Current Path		Control Buttons	
Item #	Function	Button	Function
1	Rectifier indicator (AC to DC)	EPO	EPO switch
2	Battery indicator (backup DC power)	INVERTER ON	Inverter start button
3	Bypass input indicator	INVERTER OFF	Inverter shutdown button
4	Inverter indicator (DC to AC)	FAULT CLEAR	Fault reset button
5	Load indicator (AC output)	SILENCE ON/OFF	Alarm mute button
6	UPS status and alarm indicator	Menu Buttons	
7	Audible alarm (buzzer)	Button	Function
8	Protective cover for EPO button	F1 through F4 and HELP	LCD menu keys



NOTE

Help button menus are not active. Future units will ship with an F5 legend in place of the HELP legend.

9.2 Mimic Display Indicators

Figure 68 Mimic display indicators location

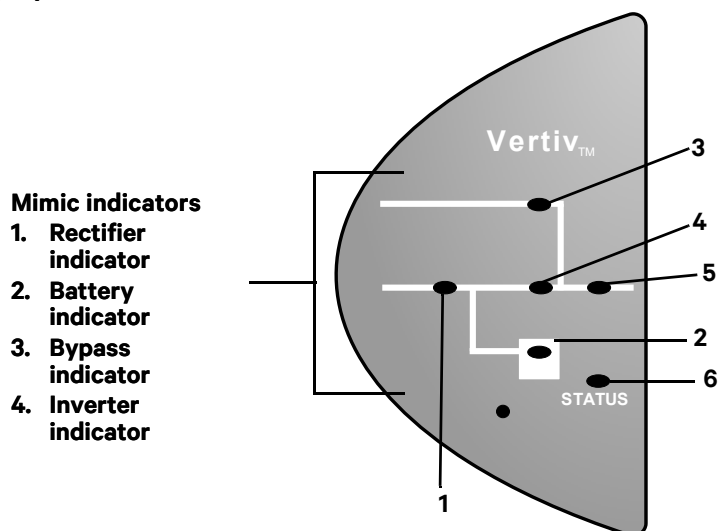

Mimic indicators show the operational status of the Liebert APM by their color—green, amber or red—and whether they are ON (solid), flashing or OFF. **Table 23** provides a guide to interpreting the various states of the indicators.

Table 23 Mimic display status indicators

Indicator (see Figure 68)	Green	Flashing Green / Amber	Red	Off
1. Rectifier	Load on Rectifier	Flashing Green: Utility normal, but rectifier not operating	Rectifier fault	Rectifier is normal, but utility is abnormal
2. Battery	Battery Powering the Load	Flashing Green: Battery pre-warning (low battery)	Battery or battery converter abnormal*	Battery and converter are normal, and battery is not discharging
3. Bypass	Load on Bypass Power	—	Bypass out of normal range	Bypass Normal
4. Inverter	Inverter Powering the Load Normally	Flashing Green: Inverter on standby	Inverter fault	Inverter normal but Off
5. Load	UPS output On	—	UPS output overloaded	UPS has no output power
6. Status	No Alarms—UPS Working Normally	Amber: UPS has a general alarm	UPS has a serious alarm	—

* Battery or battery converter abnormal events include these event messages (see **Table 57**): No Battery, Battery Replaced, Battery Reverse, Batt. Conv. Over. Curr., Batt. Converter Fault, Batt. Converter Overtemp.

9.3 Control Buttons

The Control Buttons on the front panel may be used to shut down the UPS completely, turn the inverter on or off, restart the UPS after a fault and silence the alarm, as shown in **Figure 69**. The function of each button is described in **Table 24**.



NOTE

To activate a button properly, press and hold until you hear a short beep—about two seconds.

Figure 69 Control button layout

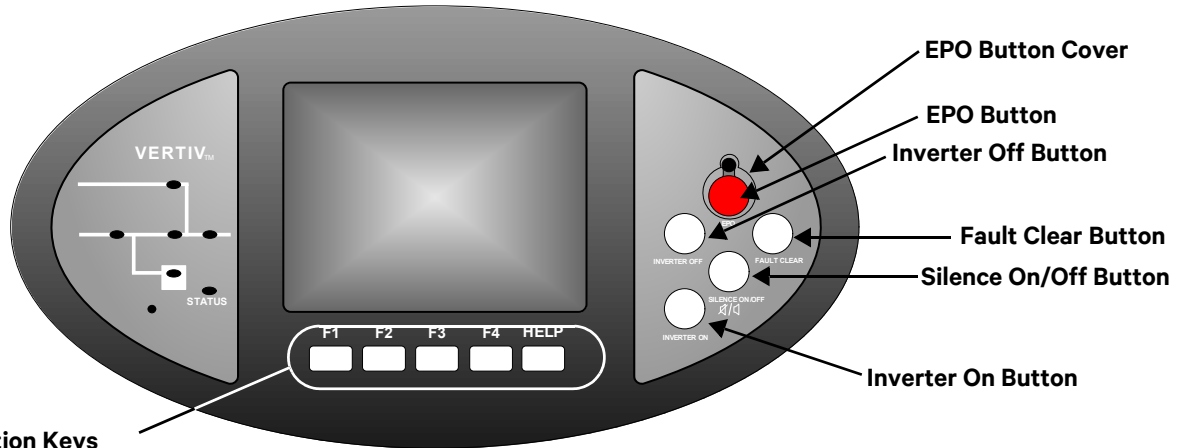

Table 24 Control buttons

Button (see Figure 69)	Function
EPO	Completely shuts down the UPS, including the static switch. CAUTION: Use caution before pressing the Emergency Power Off (EPO) button. This button completely shuts down the unit and the critical load.
INVERTER ON	Press this button to start the inverter and transfer from static bypass to inverter. NOTE: If the inverter is not ready, this will not activate the UPS.
INVERTER OFF	Press this button to shut down the inverter during operation. The load will be transferred to static bypass.
FAULT CLEAR	After the UPS shuts down due to a fault and the alarm condition has been resolved, press this button to clear the fault and restart the UPS.
SILENCE ON/OFF	Press this button once to silence the alarm buzzer when an alarm is active. Any new fault will sound the buzzer again. If the alarm buzzer is not beeping, press this button to test the alarm sound.

9.4 Alarm Buzzer

The alarm buzzer produces three types of sounds:

- Single beep—When any Control button is pressed
- Single beep repeating every two seconds—The system has a general alarm
- Continuous—The system has a serious fault

If the alarm buzzer makes no sound, the system may be operating properly or the alarm may have been silenced manually.

Figure 70 Alarm buzzer location

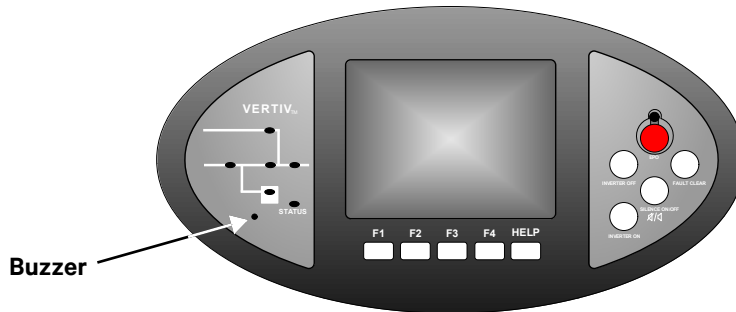

9.5 LCD Overview

The LCD on the front panel has five main sections, as shown in **Figure 71**. Press the F1 key below the LCD to scroll through these sections.

- UPS system information - view UPS name and model, date and time, overall status.
- LCD Menu - choose a category of data items to appear below the menus (see **Table 26**).
- Data and settings - view data items for the selected menu (see **Table 26**).
- Current status messages - check the most recent UPS event and alarm messages (see **Table 57**).
- Navigation key icons - look at the icon above each navigation key to determine how the key operates when pressed (see **9.6 - Navigation Keys**).

The LCD displays alarm information in real time. After appearing in the current status section of the LCD, status messages are stored in the history log—512 records can be stored and retrieved.

Figure 71 Sections of the LCD

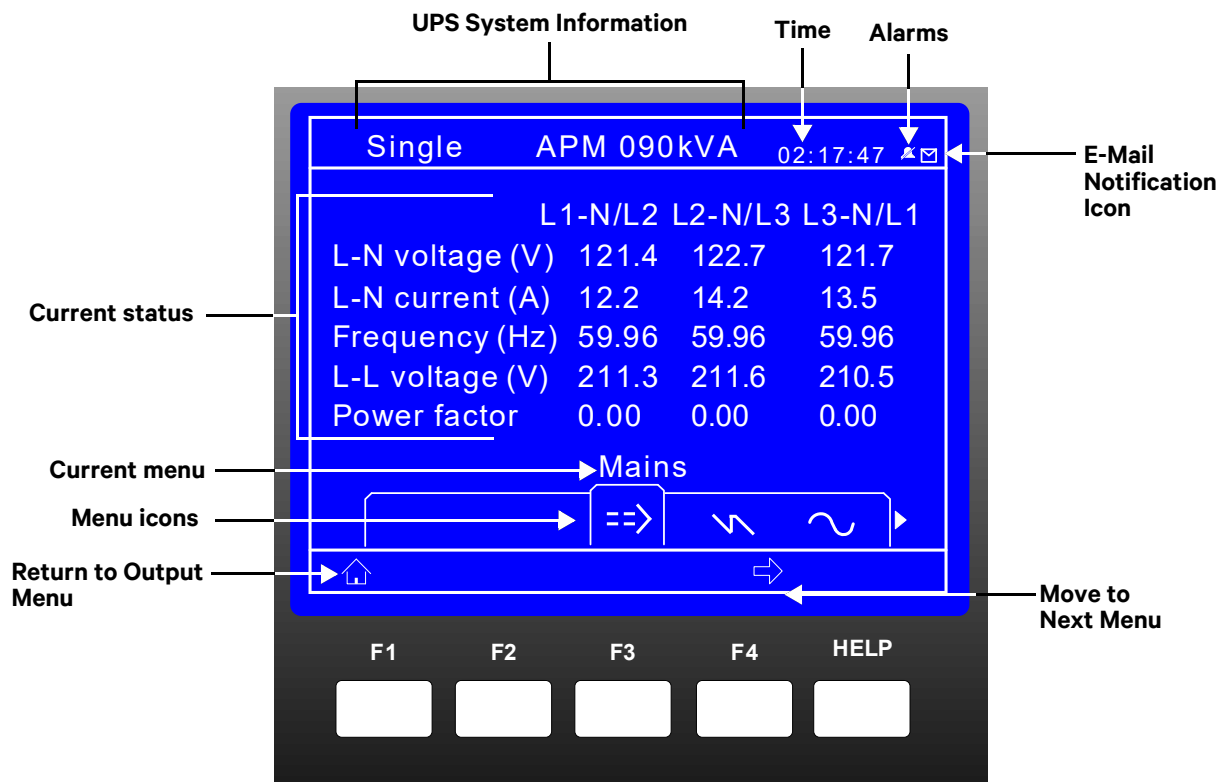





9.6 Navigation Keys

The navigation keys on the front panel—F1 through F4 and Help—are used to access the LCD to view the current status and other information about the Liebert APM.

Navigation key icons on the LCD appear above each key to indicate its operation (see **Table 25**). The keys are “soft keys” that can change functions according to the icon.

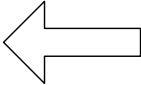
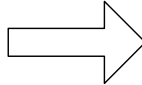
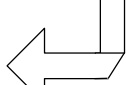
- Use F1 to move to the home portion of the LCD.
- Use F3 and F4 as cursor keys to move left and right or up and down, depending on the icons displayed above the keys.
- Use F3 and F4 on the display simultaneously to view individual Module information such as Input and Output conditions and individual Module Firmware versions
- Use F2 as an ESC key.
- Use HELP to access help information on the LCD or to enter a choice.

Table 25 Icons for navigation keys

Key	F1	F2	F3	F4	HELP
Functions Available	 Home	ESC Exit	 Left	 Right	 Enter
			 Up	 Down	 Help

9.7 LCD Menus and Data Items

The LCD menus provide access to the following categories of information and settings for the UPS. Selecting a menu changes the information displayed in the UPS data items portion of the LCD. The menu choices are listed below and described in detail in **Table 26**.

- Mains - view utility power input data: voltage, current, frequency and power factor
- Bypass - view bypass data: voltage and frequency
- Output - view output data: voltage, current, frequency and power factor
- Load - view load data: load percent, output current, output power and crest factor (CF)
- System - view system data
- Battery - view battery characteristics—voltage, current, temperature, remaining time and capacity—and messages when the battery is boost/float charging or disconnected
- Events - view the events log—displays all recent events added to the log (new records added at end)
- Records - access the history log—displays all records in the log (new records added at end)
- Language - select a language for LCD text (choices appear in the native language)
- Settings - configure UPS settings: adjust the display contrast, choose a format for date display, set the date and time, set up the UPS for modem communications (baud rate, address, mode and phone numbers to dial for alarm notifications) and change the password
- Command - start or stop a battery maintenance test, battery capacity test or system test
- Run Time - view available backup time for the UPS and bypass
- Version - view firmware versions for the inverter, rectifier and software display board and the model information for the UPS

Figure 72 shows a menu tree of the options available from the LCD menus.

Figure 72 Menu tree

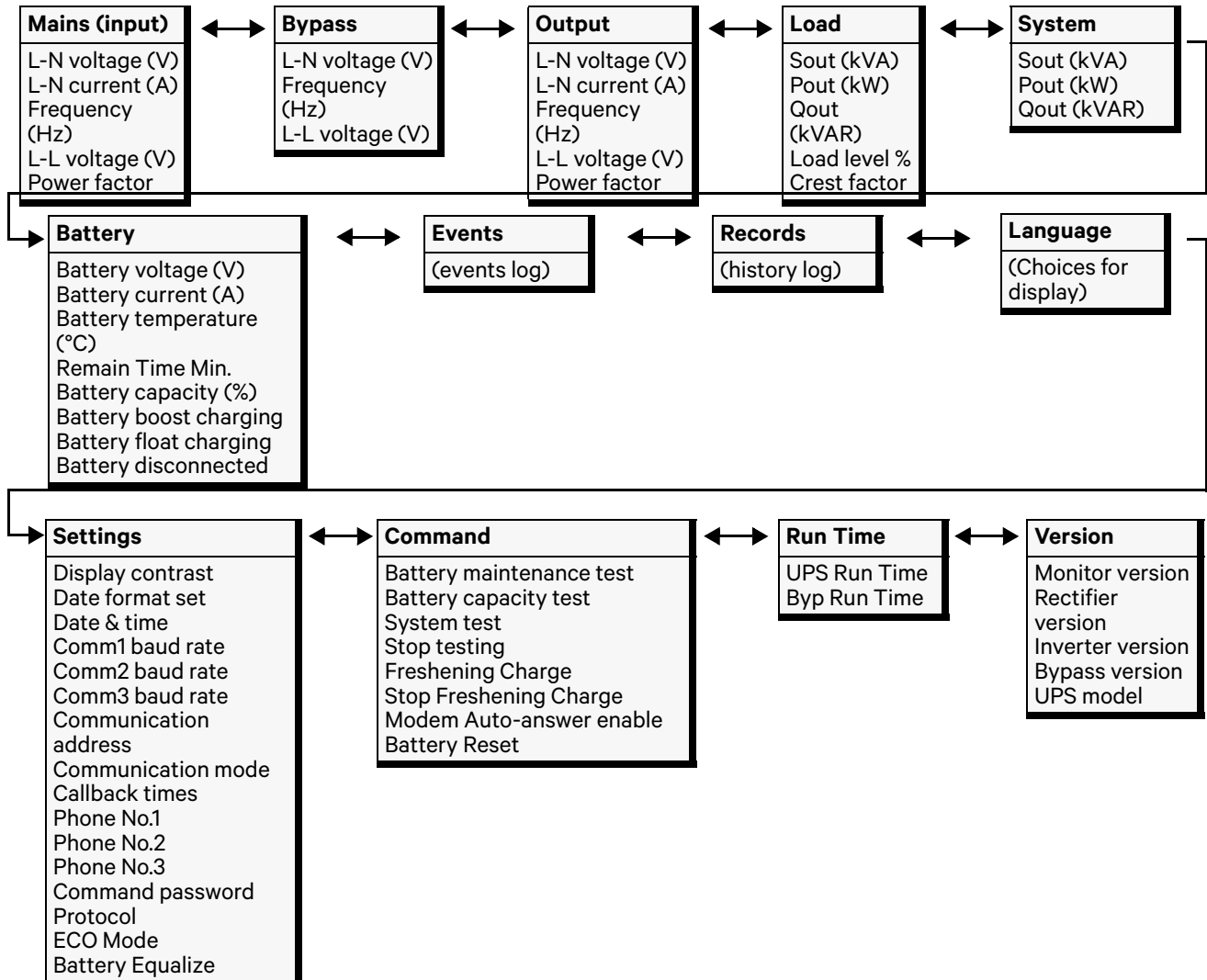

9.8 Language Selection

The LCD menus and data display are available in 12 languages (Chinese, Dutch, English, French, German, Italian, Japanese, Polish, Portuguese, Russian, Spanish and Swedish). To select a different language:

1. From the main menu, press the F4 (shift) key to move the cursor to the Language menu at the bottom of the screen.
 2. Press HELP to access the language choices.
 3. Press F3 and F4 (left and right arrows) as needed to highlight the desired language.
 4. Use HELP to select the required language.
 5. Return to the main menu by repeatedly pressing F2 (ESC) and F1.
- All text on the LCD will now be displayed in the selected language.

Figure 73 Language selection screen



9.9 Current Date and Time

To change the system date and time:

1. From the main menu, press the F4 (shift) key to move the cursor to the Settings menu at the bottom of the screen.
2. Press HELP to select the Settings menu.
3. Use F3 and F4 (up and down) to select the Date & Time option, then press HELP (enter).
4. Use F4 to position the cursor on the row where the date and time are displayed, then press HELP (enter).
5. Using the F3 (up), enter the current time and date information.
6. Press HELP (enter) to save the settings.
7. Press F2 (ESC), then F1 to return to the main screen.

Figure 74 Date and time screen

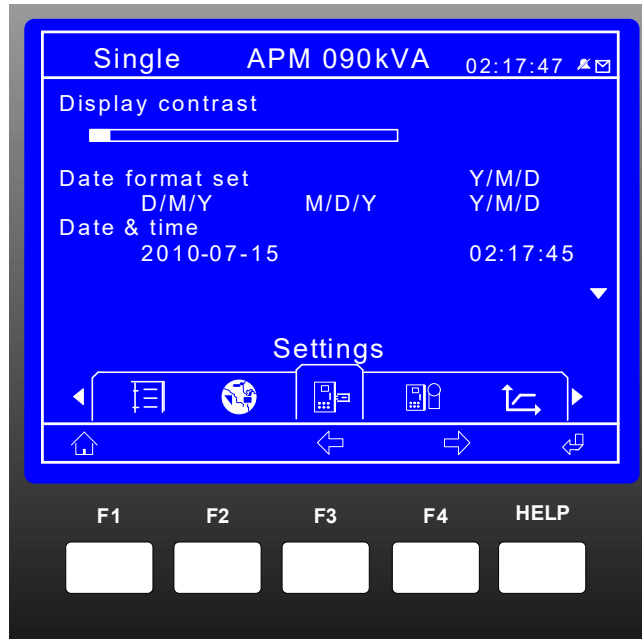

9.10 UPS History Log

The Liebert APM displays status changes as they occur and stores that data in the history log, as shown in **Figure 75**.

- History Log: When a record moves to the history log, the time the status changed is recorded. The history log can hold up to 512 records. History log records may be viewed by accessing the Records menu.

Figure 75 History log records

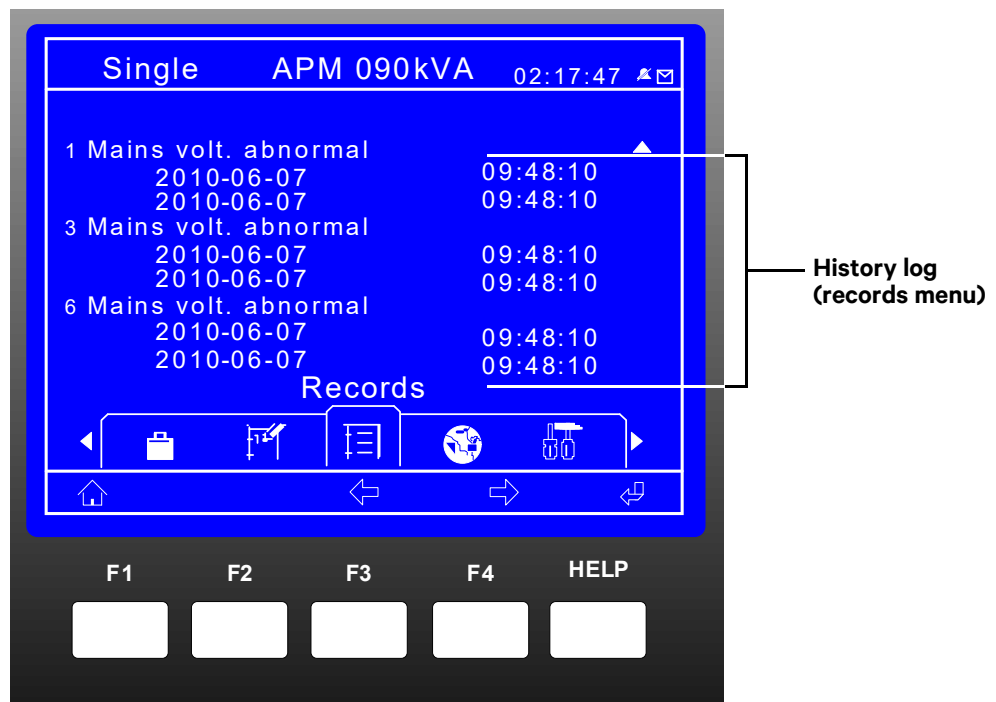

See **Table 57** for a complete list of status messages, along with a description and any recommended actions.

9.11 Types of LCD Screens

This section provides a quick guide to the main types of LCD screens.

9.11.1 Opening Display

As the UPS begins powering up, the opening display appears, as shown in **Figure 76**.

Figure 76 Opening display



9.11.2 Default Screen

After the UPS has powered up and completed a self-test, the output screen appears, as shown in **Figure 77**. This window is the default screen.

Figure 77 Default screen

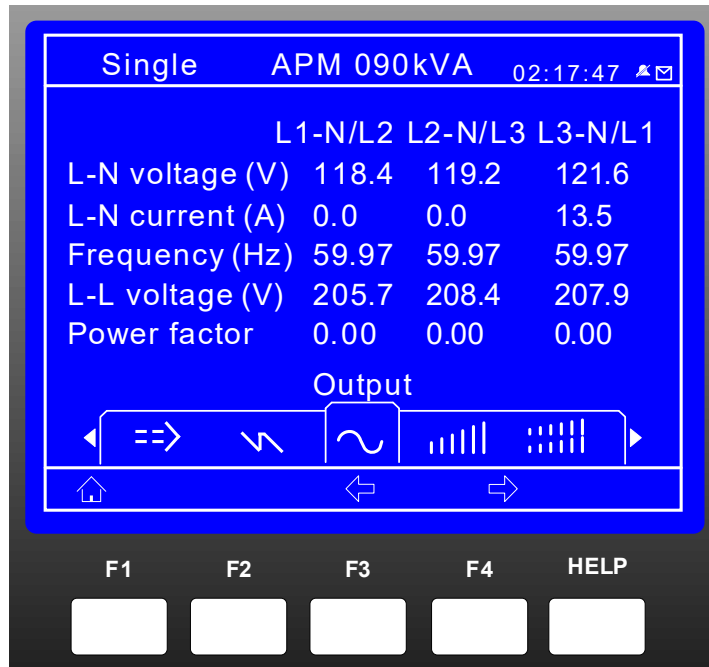

9.11.3 UPS Help Screen

Press the HELP key below the LCD to display the Help window. (Press the HELP key again to exit the Help window.)

9.11.4 Screen Saver Window

If there has been no interaction with the Liebert APM's LCD for 2 minutes, the screen saver window appears. It remains on the LCD for 2 minutes, then the screen will go dark. The LCD will become active again when any key is pressed.

Figure 78 Screen saver window

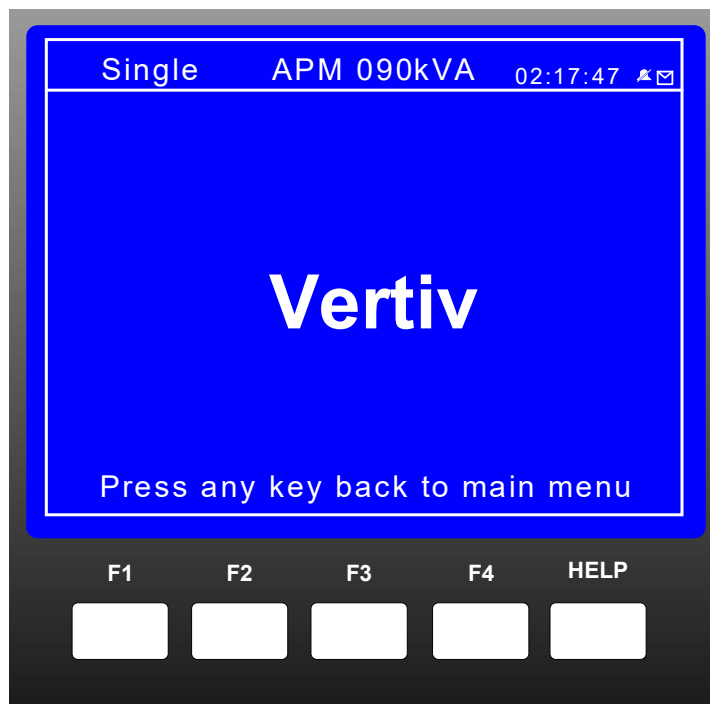

9.12 Pop-Up Windows

Pop-up prompt windows appear when the user must confirm a choice or perform an operation. This section describes the pop-up windows. Some operations require entering a password; refer to **9.12.9 - Enter Control Password** for help.

9.12.1 From Bypass to Inverter Mode With Power Interruption

If the bypass voltage or frequency exceeds the synchronized range and utility voltage or frequency is normal, the inverter cannot be in synchronization with the bypass, and the output can only transfer to inverter after an interruption of about 15ms when the user presses the INVERTER ON button. Before transferring, the system will let the user confirm whether the interruption can be accepted, as shown at right. If the bypass voltage returns to normal before the user makes confirmation, the UPS will transfer to inverter mode automatically. At the same time, the prompt window will close.

Transfer with Interrupt,
please confirm or cancel

9.12.2 From Inverter to Bypass Mode With Interruption

If the bypass voltage or frequency exceeds the synchronized range and the UPS is in inverter mode, the system must let the user confirm and accept the power interruption danger before pressing the INVERTER OFF button to shut down the output of the inverter. The user can also cancel the shutdown operation, as shown at right. If the bypass voltage returns to normal before the user makes the confirmation, the UPS will transfer to bypass operation mode automatically, and at the same time the prompt window will disappear soon.

This operation leads to
output shutdown
Confirm or cancel

9.12.3 System Self-Test

When a system self-test is completed, a pop-up window reports the results of the test, as shown at right.

- Press the Help (Enter) key and the pop-up window closes.

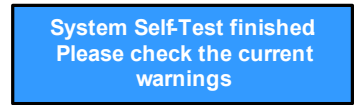

9.12.4 Battery Capacity Test Confirmation

When a battery capacity test is started from the Command menu, the battery will be discharged to low-battery warning level. The Liebert APM asks for confirmation before the test is started, as shown at right.

- To confirm the choice and begin the battery capacity test, press the Help (Enter) key and the pop-up window disappears.
- To cancel the test, press the F2 (ESC) key. The pop-up window disappears.

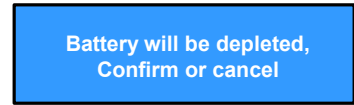

NOTE

For a battery capacity test to function properly, the load must be between 20% and 100%.

9.12.5 Battery Self-Test Aborted, Condition Not Met

When a battery capacity test is started from the Command menu and the battery self-test condition is inadequate, the Liebert APM will not perform a battery test. User should check whether the battery state is boost charging and whether the load level is greater than 20 percent.

- Press the Help (Enter) key and the pop-up window closes.

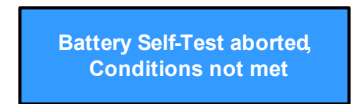

9.12.6 Battery Equalize Charge

The user can Enable or Disable the Battery Equalize Charge of the batteries. Use the F3 or F4 button to Enable or Disable the Battery Equalize feature.

- Press the Help (Enter) key and the pop-up window closes.

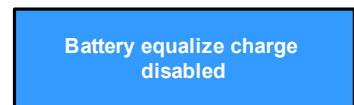
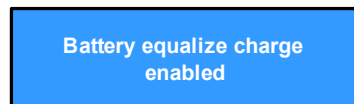

9.12.7 Battery Reset

The user can reset the battery statistics to a new battery state. Use the F3 or F4 button to select Battery Reset

- Press the Help (Enter) key and the pop-up window closes.



9.12.8 Battery Refresh Charge Aborted, Condition Not Met

When a battery refreshing charge is started from the Command menu and battery refreshing condition fails to meet requirements, the Liebert APM will not perform a battery refreshing charge. User should check if boost charging condition is not enough, such as (No battery, charger failed, etc.).

- Press the Help (Enter) key and the pop-up window closes.

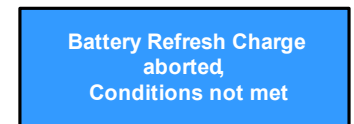

9.12.9 Enter Control Password

When a UPS control operation requires a password, the pop-up at right will be displayed. The password is 12345.

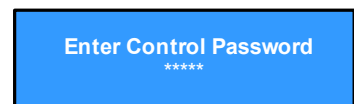

Use the Right or Left arrow to move the cursor along the password field. Then use the Up and Down arrows to advance until the desired number is displayed. Enter the password one digit at a time.

Table 26 UPS menus and data window items

Menu Type	Item Type	
Mains (input)	L-N voltage (V)	Phase voltage
	L-N current (A)	Phase current
	Frequency (Hz)	Input frequency
	L-L voltage (V)	Line-line voltage
	Power factor	Power factor
Bypass	L-N voltage (V)	Phase voltage
	Frequency (Hz)	Bypass frequency
	L-L voltage (A)	Line-line voltage
Output	L-N voltage (V)	Phase voltage
	L-N current (A)	Phase current
	Frequency (Hz)	Output frequency
	L-L voltage (V)	Line-line voltage
	Power factor	Power factor
Load	Sout (kVA)	Sout: Apparent power
	Pout (kW)	Pout: Active power
	Qout (kVAR)	Qout: Reactive power
	Loadlevel %	The percent of the UPS rating load
	Crest factor	Output current Crest Factor
System	Sout (kVA)	Sout: Apparent power
	Pout (kW)	Pout: Active power
	Qout (kVAR)	Qout: Reactive power
	Single unit	When configured as a single unit, UPS displays only native load, no system load.
Battery	Battery voltage (V)	Battery bus voltage
	Battery current (A)	Battery bus current
	Battery temperature (°C)	Internal battery temperature °C
	Remain Time Min.	Battery run time remaining
	Battery boost charging	Battery is boost charging
	Battery float charging	Battery is float charging
	Battery equalize charging	Battery charge is equalized
	Battery disconnected	Battery is not connected
Events	(event log)	Displays recent events
Records	(history log)	Displays all records in the history log
Language	(choices for text displayed)	User may select any of 12 languages for LCD text.

Table 26 UPS menus and data window items (continued)

Menu Type	Item Type	
Settings	Display contrast	Adjust the LCD display contrast
	Date format set	Choose the format for date display: YYYY MM DD, DD MM YYYY and MM DD YYYY
	Date & time	Set the date and time
	Comm1 baud rate	Communication baud rate setting for Liebert IntelliSlot 1
	Comm2 baud rate	Communication baud rate setting for Liebert IntelliSlot 2
	Comm3 baud rate	Communication baud rate setting for Liebert IntelliSlot 3
	Communication address	This setting is applicable to RS485 communication mode
	Communication mode	Communication Mode Setting
	Callback times	When Liebert IntelliSlot 1 Communication mode is Modem, this parameter sets the number of times a number is redialed to send an alarm notification.
	Phone No.1	When Liebert IntelliSlot 1 Communication mode is Modem, this is the first phone number to be dialed (to send an alarm notification).
	Phone No.2	When Liebert IntelliSlot 1 Communication mode is Modem, this is the second phone number to be dialed (to send an alarm notification).
	Phone No.3	When Liebert IntelliSlot 1 Communication mode is Modem, this is the third phone number to be dialed (to send an alarm notification).
	Command password	User can modify the command password.
	Protocol	System protocol
	ECO Mode	Configures UPS for ECO mode
Battery Equalize Charge	Configures UPS for equalize charge	
Command (start/stop battery & system tests)	Battery maintenance test	This test performs a partial discharge of the battery to obtain a rough estimate of the battery capacity. Load must be between 20% and 80%.
	Battery capacity test	This test performs a full discharge of the battery to obtain a precise measure of the battery capacity. Load must be between 20% and 80%.
	System test	This is a self-test of the UPS. When the user activates this function, a pop-up window appears about 5 seconds later to show the results.
	Stop testing	Manually stops a battery maintenance test, battery capacity test or system test.
	Freshening Charge	Allows a temporary Equalize charge for the batteries. This charge is configurable for 1 to 36 hours.
	Stop Freshening Charge	Manually stops a Freshening Charge.
	Modem Auto-answer enabled	Manually enable the modem's auto-answer function.
	Battery Reset	Resets battery statistics
Run Time	UPS Run Time	UPS Run Time
	Byp Run Time	Bypass Run Time
Version	UPS model	Provides UPS model information—for example, 208V-60Hz.
	Monitor Version	Monitor Firmware Version
	Rectifier Version	Rectifier Firmware Version
	Inverter Version	Inverter Firmware Version
	Bypass Version	Bypass Firmware Version

10.0 OPERATION

10.1 Liebert APM Operating Modes

The UPS is designed to operate as an on-line, double-conversion, reverse-transfer system in the following modes:

- Normal Mode
- Battery Mode
- Auto-Restart Mode
- ECO Mode
- Bypass Mode
- Battery Start Mode
- Maintenance Mode (Manual Bypass)
- Sleep Mode
- Paralleling Mode
- Output Voltage Adjustment
- Generator Mode



NOTE

1. The user controls and indicators mentioned in these procedures are identified in **9.0 - Operator Control and Display Panel**.
2. The audible alarm may sound at various points during these procedures. It can be canceled at any time by pressing the SILENCE ON/OFF push button.



NOTE

This unit refers to some modes and conditions that are set or adjusted using proprietary service software. To take advantage of all the available features for the Liebert APM, the unit must be commissioned by a Vertiv-authorized engineer.

Normal Mode

Operating in normal mode, the Liebert APM's rectifier derives power from a utility AC source and supplies regulated DC power to the inverter, which regenerates precise AC power to supply the connected equipment. The rectifier also uses the utility source power to charge the batteries.

Battery Mode

When utility AC power fails, the Liebert APM protects the critical load by instantaneously channeling battery power to the inverter which continues supporting the critical load without interruption. When utility power returns and is within acceptable limits, the Liebert APM automatically shifts back to Normal mode, with the rectifier powering the critical load.

Auto-Restart Mode

The battery may become exhausted following an extended AC utility failure. The inverter shuts down when the battery reaches the End of Discharge voltage (EOD). The UPS may be programmed to "Auto Recovery after EOD" after a delay time if the AC utility recovers. This mode and any delay time may be programmed by the commissioning engineer.

Bypass Mode

When the Liebert APM is in bypass mode, the load is directly supported by utility power and is without battery backup protection.

The Liebert APM's static transfer switch will shift the load from the inverter to bypass mode without interruption in AC power if the inverter is synchronous with the bypass and any of the following occurs:

- inverter fails
- inverter overload capacity is exceeded
- inverter is manually turned off by user



NOTE

If the inverter is asynchronous with the bypass, the static switch will transfer the load from the inverter to the bypass WITH interruption in AC power to the critical load. This interruption will be less than 15ms (in 50Hz), or less than 13.33ms (in 60Hz). This interruption time may be altered by modifying the Output transfer interrupt time setting.

ECO Mode (Single-Module UPS System Only)

When ECO mode is selected, the Liebert APM switches inverter power from the UPS input to the bypass input to save energy by improving UPS efficiency. In this mode, the bypass is the preferred source. If the bypass voltage or frequency becomes outside preset limits, the UPS load is transferred back to the inverter.

Battery Start Mode

The battery start option permits starting the Liebert APM with power supplied only by the batteries (at charged condition).

Maintenance Mode

For maintenance or repair, the Liebert APM may be operated in maintenance mode. To place the Liebert APM in maintenance mode, follow the instructions in **10.4 - Switching the UPS from Normal Operation to Maintenance Bypass**.



WARNING

Risk of arc flash and electric shock. Can cause equipment damage, injury and death. The UPS input and output must be protected with external overcurrent protection devices. In maintenance mode, the input and output busbars remain energized and present an electric shock hazard.

Sleep Mode

Sleep mode allows equal run time on all power modules. The modules will put themselves offline for a programmable period of 0-30 days. As a module goes offline, another module comes online. Each module will rotate being online and offline.

Sleep Mode must be enabled by a Vertiv Customer Engineer. A minimum of three power modules are required for Sleep Mode to be activated. Once enabled, Sleep Mode requires no further action.

Any Power Modules that are not supporting the load will automatically enter sleep mode. During sleep mode the system maintains one extra active power module in addition to those supporting the load. Sleep mode can handle configurations with redundant power modules. When a power module is in Sleep Mode, both LED indicators will turn Off. During extended periods of Sleep Mode, the inactive power module is cycled through at regular intervals

Common Battery

Common Battery feature permits two Liebert APM's to be connected to one battery cabinet. The UPS's may be separate systems or may be in a parallel system. LBS cannot be used while common battery is enabled.

Paralleling Mode

This option is available only on 208V Input Parallel. This mode requires the buyout panelboard paralleling gear. It can parallel the following:

- two APM's
- 45kW or 90kW frames in any module capacity
- redundant
- can allow up to 180kW of load capacity

A sharing inductor is required for parallel units.



NOTE

To parallel non-208 input voltages, an upstream transformer must drop the input voltage to 208V before the paralleling gear.

Output Voltage Adjustment

This feature allows a Liebert Customer Engineer to adjust the APM's output voltage over a range of -5% to +16% of nominal. The output voltage adjustment can be used to compensate for any drop in line voltage that may occur when the UPS is a significant distance from the protected load. In addition, it can be used to optimize the UPS output voltage for loads that operate more efficiently at a voltage different from the nominal Liebert APM output voltage.

Generator Mode

The Liebert APM UPS can be set up for operation in Generator Mode by a Vertiv engineer. The setup requires connecting J9 Pin 1 to Pin 4 or connecting J9 Pin 2 to Pin 4. The software must be configured to reflect the connection points as attached.

10.2 UPS Startup

The Liebert APM must be fully installed and commissioned before startup, and external power isolators must be closed. Once those general conditions are met, the UPS may be started.



WARNING

Risk of electrical shock and arc flash. Can cause property damage, injury and death. During this procedure the output terminals will become live.

If any load equipment is connected to the UPS output terminals, please check with the load user and ascertain whether it is safe to apply power to the load. If the load is not ready to receive power, then ensure that it is safely isolated from the UPS output terminals.

10.2.1 Startup Procedure

To start the UPS from a fully powered-down condition:

1. Open the external power switch.
2. Open the UPS door.
3. Connect the power supply cables.
4. Ensure the correct phase rotation.
5. Confirm that the address DIP switch of the main Liebert FlexPower assemblies are different from each other, and they are within 1 to 6. If they are the same, adjust them to create different Liebert FlexPower assembly addresses.

Table 27 Dip switch matrix

FlexPower Assembly Address					
Flex Power Assembly Address Top to Bottom	DIP Switch Number Left to Right				
	1	2	3	4	5
6	Down	Up	Up	Down	Down
5	Up	Down	Up	Down	Down
4	Down	Down	Up	Down	Down
3	Up	Up	Down	Down	Down
2	Down	Up	Down	Down	Down
1	Up	Down	Down	Down	Down



NOTE

For standardization, if the quantity of modules in system is less than 6, for example 45kVA system, Vertiv recommends setting the address bits of the modules as 1, 2, 3 respectively.

- Close the external input circuit breaker and connect input power. The LCD activates. The rectifier indicator flashes while the rectifier is starting. The rectifier enters normal operation state, and after about 30 seconds, the rectifier indicator stops blinking and is illuminated in a steady green. After initialization, the bypass static switch turns on. The mimic LEDs appear as shown

Table 28.

Table 28 Mimic indicators after initialization

LED	Status
Rectifier Indicator	Green
Battery Indicator	Red
Bypass Indicator	Green
Inverter Indicator	Off
Load Indicator	Green
Status Indicator	Amber

- Ensure that the Liebert FlexPower assembly ready switches are latched (in Down position).
- Close the external output circuit breaker.
- Press the INVERTER ON button for 2 seconds. The inverter indicator flashes while the inverter is starting. After the inverter is ready, the UPS transfers from bypass to inverter, the bypass indicator turns Off, and the inverter indicator turns On. The UPS is in Normal Mode. The mimic LEDs will appear as shown below.

Table 29 Mimic indicators for normal mode operation with battery breaker open

LED	Status
Rectifier Indicator	Green
Battery Indicator	Red
Bypass Indicator	Off
Inverter Indicator	Green
Load Indicator	Green
Status Indicator	Amber

10. Close the battery breaker.

Table 30 Mimic indicators for normal mode operation with battery breaker closed

LED	Status
Rectifier Indicator	Green
Battery Indicator	Off
Bypass Indicator	Off
Inverter Indicator	Green
Load Indicator	Green
Status Indicator	Green

10.2.2 Startup in ECO Mode

ECO Mode is available only on a single-module Liebert APM.

1. Verify that input power is available.
2. Select ECO Mode on the Control Panel.
3. Verify that the Bypass indicator remains green to indicate that the load is supplied by the bypass input. The UPS is now operating in ECO Mode.

10.2.3 Switching Between UPS Operation Modes

To switch from Normal Mode to Static Bypass Mode—Press the INVERTER OFF button to switch to Bypass Mode (see **Figure 69**).



NOTE

In Static Bypass Mode, the load is being powered by the utility and is not protected from fluctuations in input power: spikes, sags and failure.

To Switch From Bypass Mode To Normal mode—When the UPS is in Bypass Mode, press the INVERTER ON button. After the inverter enters normal operation, the UPS transfers to Normal Mode.

To switch from Normal Mode to ECO Mode—Select ECO Mode using the Liebert APM control panel. After a 5-minute qualification of the bypass voltage, the UPS will transfer to bypass.

The Bypass indicator on the MIMIC display will illuminate Green to indicate that the UPS is operating properly with input power from the bypass input. The Inverter indicator will flash Green to indicate that the Inverter is on standby operating in ECO mode.



NOTE

In ECO Mode, the load is being powered by the utility as long as the bypass source remains within set limits.

To switch from ECO mode to Normal Mode—When the UPS is in ECO Mode, press the INVERTER ON button. After the inverter enters normal operation, the UPS transfers to Normal Mode.

10.3 UPS Battery Start

The battery start option permits starting the Liebert APM with power supplied only by the batteries (at charged condition).

CAUTION

Before attempting to start the UPS without utility power present, ensure that the batteries are fully charged—over 2.1V per cell—and will supply adequate run time to the load.

1. Verify that the battery cabinet is properly connected (see **Figure 40**) and that the battery breaker is closed.
2. Press the battery start button on the front panel of any Liebert FlexPower assembly for two seconds (see **Figure 79** for the button's location).

The LCD displays the start screen, and the battery indicator flashes green. It stops flashing and becomes solid green about 30 seconds after the rectifiers enter normal operation.

3. Press and hold the INVERTER ON key for two seconds, and the UPS will begin operating in battery mode.

Figure 79 Battery start button location

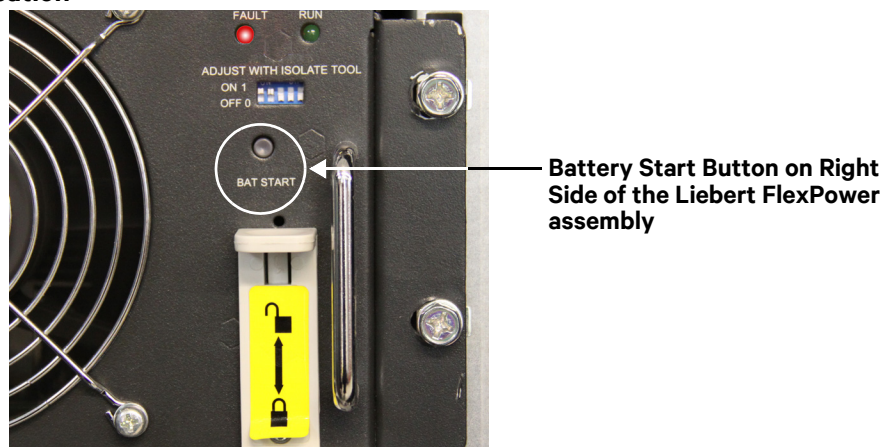

10.4 Switching the UPS from Normal Operation to Maintenance Bypass

Follow the procedure below to transfer the load from the UPS inverter output to the Maintenance Bypass system.



CAUTION

This procedure must be performed by properly trained and qualified personnel who are knowledgeable about the operation of this system. Failure to follow these instructions will result in loss of power and possible damage to critical equipment.

Before performing this operation, read any messages on the LCD to be sure that bypass supply is regular and the inverter is synchronous with it. If those conditions are not present, there is a risk of a short interruption in powering the load.

This procedure assumes that UPS is operating normally.

1. Press the INVERTER OFF button on the right side of the Operator Control Panel for longer than 2 seconds.

The Inverter indicator will turn Off, the status indicator will turn amber and an audible alarm will sound. The load will transfer to static bypass (internal) and the inverter will shut off.



NOTE

Pressing the Alarm Silence Switch cancels the audible alarm, but leaves the warning message displayed until the appropriate condition is rectified.

2. Open the Liebert BDC door to gain access to the bypass isolation breaker (BIB), maintenance bypass breaker (MBB) and maintenance isolation breaker (MIB).
3. When the lamp indicator on the BDC is illuminated, press and hold the adjacent push button and remove the Key from the lock (KO).
4. Insert the Key into the lock on the MBB and turn the Key.
5. Close the MBB.
6. Verify the MBB is closed. Failure to close the MBB will interrupt power to the load.
7. Open the MIB.
8. Remove the key from the lock on the MIB. Insert the key into the lock (KO) and turn the key.
9. The UPS system is now isolated from the critical load.
10. For a single-input system, the bypass isolation breaker (BIB) remains closed; this allows power to remain present at the UPS input; refer to **Figure 83**.
11. For a single-source, dual-input system, the bypass isolation breaker (BIB) can be opened to further isolate the UPS from input power; refer to **Figure 80**.



WARNING

Risk of electrical shock and arc flash. Can cause property damage, injury and death. Wait 5 minutes for the internal DC busbar capacitors to discharge before attempting to remove the internal protective barriers.



WARNING

Risk of electrical shock and arc flash. Can cause property damage, injury and death. Even with the UPS in maintenance bypass and Off, portions of the Liebert APM system are still energized. Service must be performed by properly trained and qualified personnel only.

NOTICE

Risk of power loss to connected load. Can cause damage to equipment.

The load equipment is not protected from normal supply aberrations when the Liebert APM is operating in the maintenance bypass mode.

10.5 Switching the UPS from Maintenance Bypass to Normal Operation

Follow the procedure below to transfer the load from the Maintenance Bypass system to the UPS inverter output.

These conditions must be met for this operation to proceed:

- the UPS must be operating normally
- the BIB breaker must be closed
- the UPS system must be in the Maintenance Bypass mode of operation.



CAUTION

Risk of electrical shock and arc flash. Can cause property damage, injury and death.

This procedure must be performed by properly trained and qualified personnel who are knowledgeable about the operation of this system. Failure to follow these instructions will result in loss of power and possible damage to critical equipment.

Before performing this operation, read any messages on the LCD to be sure that bypass supply is regular and the inverter is synchronous with it. If those conditions are not present, there is a risk of a short interruption in powering the load.

1. Verify that the Liebert APM is in Maintenance Bypass mode.



NOTE

Pressing the Alarm Silence Switch cancels the audible alarm, but leaves the warning message displayed until the appropriate condition is rectified.

2. Open the Liebert BDC door to gain access to the bypass isolation breaker (BIB), maintenance bypass breaker (MBB) and the maintenance isolation breaker (MIB).
3. When the Lamp indicator on the BDC is illuminated, press and hold the adjacent push button and remove the key from the lock (KO).
4. Insert the key into the lock on the MIB, and turn the key.
5. Close the MIB.
6. Verify the MIB is closed. Failure to close the MIB will interrupt power to the load.
7. Open MBB.
8. Remove the key from the lock on the MBB.
9. Insert the key into the lock (KO) and turn the key.

The UPS system is now supplying power to the critical load.

10. Press the INVERTER ON button on the right side of the Operator Control Panel for longer than 2 seconds. The Inverter indicator flashes while the inverter is starting.

After the inverter is ready, the UPS transfers from static bypass to inverter, the bypass indicator turns Off and the inverter indicator turns On. The UPS is in Normal Mode. The indicator will appear as shown in **Table 30**.

10.6 De-Energize Liebert APM with Maintenance Bypass Cabinet



CAUTION

This procedure will remove power from the critical bus.

To de-energize the system:

1. On the UPS control panel, press and hold the INVERTER OFF button for 2 seconds.
2. Open all battery circuit breakers(s) including internal battery breaker (if applicable).



CAUTION

Performing the next step will shut down the critical load.

3. If the MBC is a Vertiv cabinet, open the Maintenance Isolation Circuit Breaker (MIB). If the MBC is a customer-issued switchgear or a non-Vertiv cabinet, open the breaker(s) that supply power to the critical bus.
4. Open the Rectifier Input Circuit Breaker and Bypass Input Breaker (if dual input). If the MBC is a customer-issued switchgear or a non-Vertiv cabinet, open the breaker(s) that supply power to the UPS input and bypass input (if dual input).
5. Allow 5 minutes for all DC circuits and capacitors to fully discharge.
6. Open the external feeder breaker to the MBC or bypass switchgear.
7. Install a Lockout/Tagout on the external feeder breaker to the MBC or bypass switchgear.
8. Use a digital multimeter to verify there is no AC or DC voltage present at the UPS input, output and bypass bus bars.
9. Use a digital multimeter to verify there is no AC or DC voltage present at the MBC BIB, MIB and MBB breakers.

10.7 De-Energize Liebert APM Without Maintenance Bypass Cabinet



CAUTION

This procedure will remove power from the critical bus.

To de-energize the APM:

1. On the UPS control panel, press and hold the INVERTER OFF button for 2 seconds.
2. Open all battery circuit breakers(s) including internal battery breaker (if applicable).



CAUTION

Performing the next step will shut down the critical load.

3. Open the UPS output circuit breaker(s).
4. Open the UPS input circuit breaker and bypass circuit breaker (dual input systems only).
5. Allow 5 minutes for all DC circuits and capacitors to fully discharge.
6. Use a digital multimeter to verify there is no AC or DC voltage present at the UPS input, output and bypass bus bars.

Figure 80 Typical configuration for single UPS

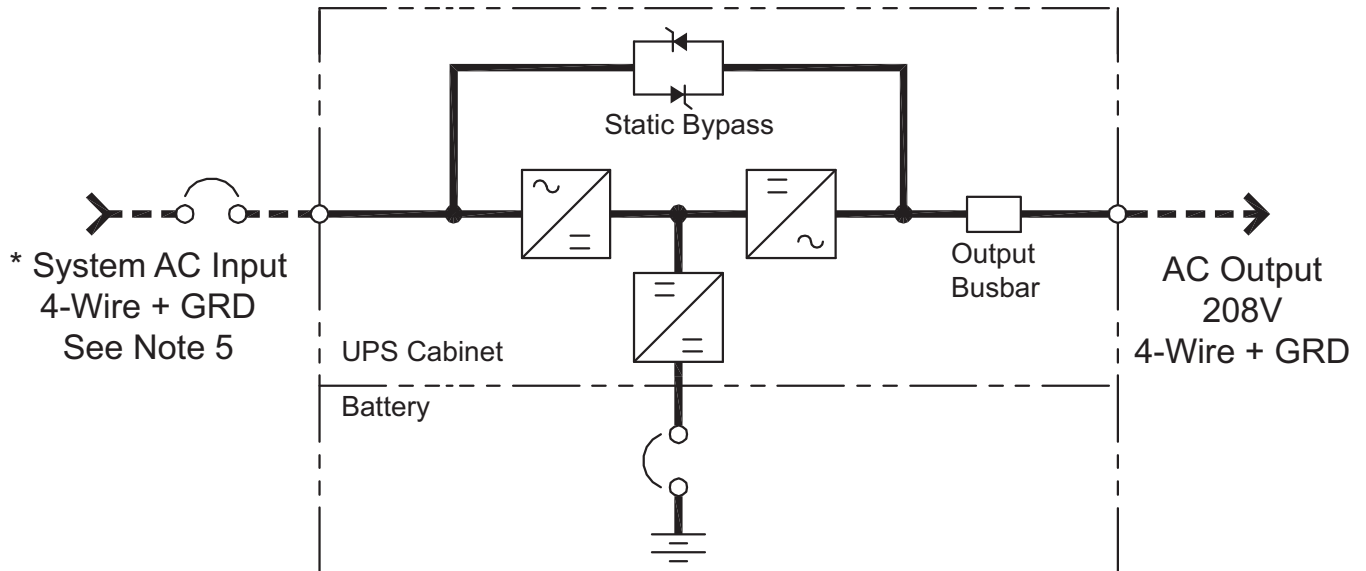

Notes

1. Install in accordance with national and local electrical codes.
2. A neutral is required from the system AC input source.
A full-capacity neutral conductor and grounding conductors are recommended.
3. UPS system input and output cables must be run in separate conduits.
4. Control wiring must be run in separate conduits.
5. Customer must supply shunt trip breaker with 120V coil.

----- Field-Supplied Wiring

* External Overcurrent Protection by Others

UAM01000
Rev. 2

10.8 Operation of Two Liebert APM Units in Parallel Setup

This section describes a variety of operations for two Liebert APM units wired for parallel operation. **Figure 81** shows the one line diagram, and subsequent sections provide detailed steps for parallel operation of the parallel units.

Figure 81 Liebert APM six-breaker buyout paralleling configuration

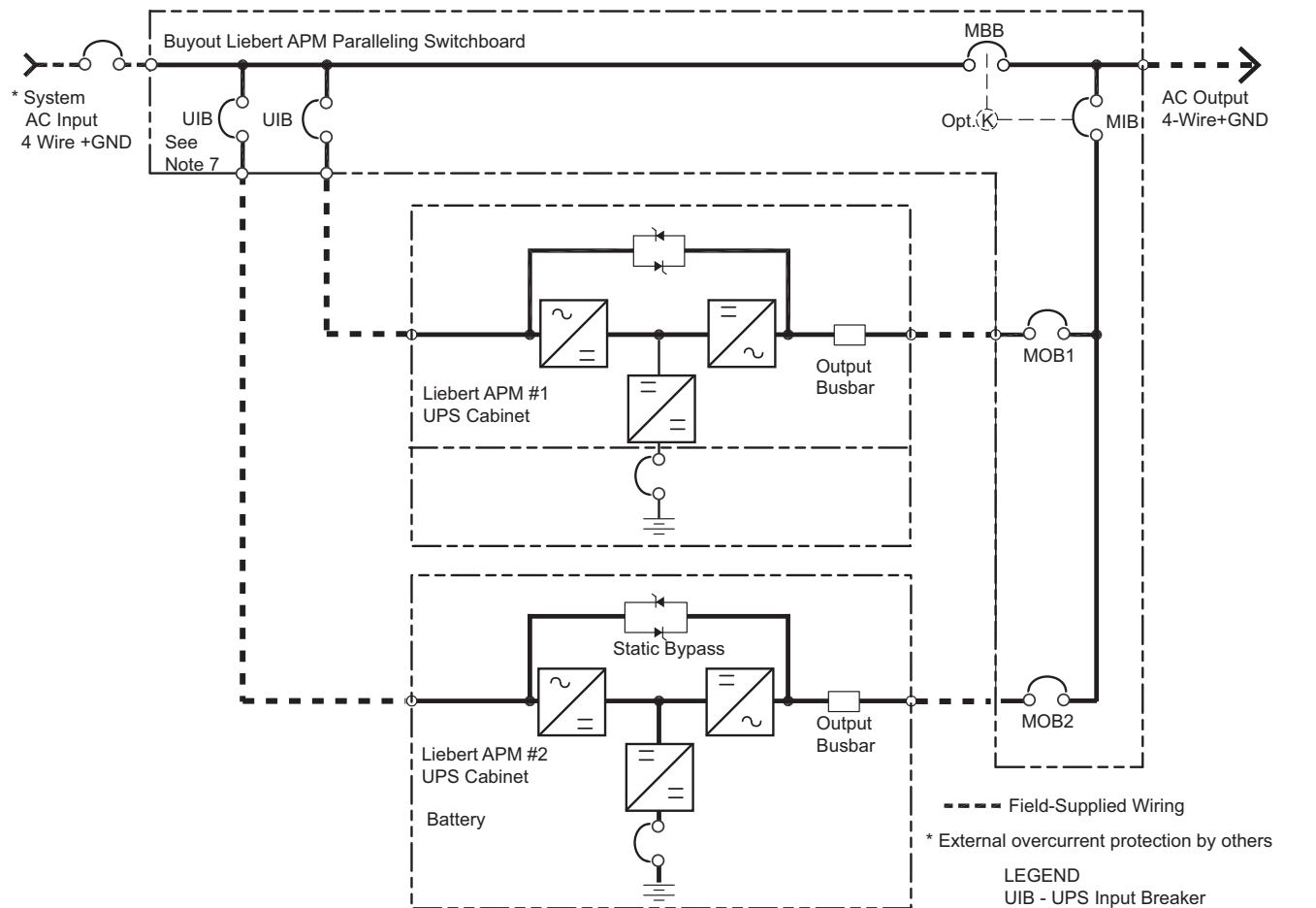

NOTES:

1. Install in accordance with national and local electrical codes.
2. Input and bypass must share the same single source.
3. A neutral is required from the system AC input source. A full capacity neutral conductor is recommended. Grounding conductors are recommended.
4. Bypass and rectifier inputs and output cables must be run in separate conduits.
5. Control wiring must be run in separate conduits.
6. The 90kVA frame has a capacity of up to six Flex Power assemblies and the 45kVA frame has a capacity of up to three Flex Power assemblies.
7. Paralleling switchboard requires shunt trip UIB breakers with 120V coils.
8. See drawings UAM01080B, UAM01080C, UAM01080D, UAM01080E and UAM01080F. Refer to the following battery cabinet control wiring drawings:
UAM04000
UAM4001A,B
UAM4002A,B D)

LEGEND
 UIB - UPS Input Breaker
 MOB - Module Output Breaker
 MIB - Maintenance Isolation Breaker
 MBB - Maintenance Bypass Breaker

UAM01060A
 Rev. 0

10.8.1 Procedure to Take UPS1 Offline While Leaving UPS2 Online

The procedure below is used to switch the system from parallel to single UPS operation.

NOTICE

Risk of improper switching. Can cause damage to connected load.
 Verify that removal of UPS1 from the system bus will NOT overload UPS2 and cause the load to drop.

1. Turn OFF the inverter on UPS1 (see **Figure 81**).
2. Verify that UPS1 is now in Static Bypass Mode.
3. Open Battery Breaker(s) for UPS1.
4. Verify that the Battery Status Light on UPS1 turns Red.
5. Open UIB1.
6. Open MOB1.
7. Verify that UPS1 is now completely OFFLINE.

10.8.2 Procedure to Put UPS1 Back Online

1. Close MOB1 (see **Figure 81**).
2. Close UIB1.
3. Verify that the Liebert APM UPS turns On.
4. Close the battery breaker for UPS1.
5. Verify that the battery status light on UPS1 turns Off.
6. Verify that UPS1 is now in Static Bypass Mode.
7. Turn on the Inverter on UPS1.

10.8.3 Procedure to Take UPS2 Offline While Leaving UPS1 Online

NOTICE

Risk of improper switching. Can cause damage to connected load.

Verify that removal of UPS2 from the system bus will NOT overload UPS1 and cause the load to drop.

1. Turn OFF the inverter on UPS2 (see **Figure 81**).
2. Verify that UPS2 is now in Static Bypass Mode.
3. Open Battery Breaker(s) for UPS2.
4. Verify that the Battery Status Light on UPS2 turns Red.
5. Open UIB2.
6. Open MOB2.
7. Verify that UPS2 is now completely OFFLINE.

10.8.4 Procedure to Put UPS2 Back Online

1. Close MOB2 (see **Figure 81**).
2. Close UIB2.
3. Verify that the Liebert APM UPS turns On.
4. Close the battery breaker for UPS2.
5. Verify that the battery status light on UPS2 turns Off.
6. Verify that UPS2 is now in Static Bypass Mode.
7. Turn on the Inverter on UPS2.

10.9 APM Procedure from Parallel Inverter Operation to Wrap-Around Bypass

Note: MBB is OPEN.

1. Turn OFF the Inverter on UPS1 (see **Figure 81**).
2. Turn OFF the Inverter on UPS2.
3. Verify that each UPS is now in Static Bypass Mode.
4. Open Battery Breaker(s) for UPS1.
5. Open Battery Breaker(s) for UPS2.
6. Verify that the Battery Status Light on UPS1 and UPS2 turns Red.
7. Close MBB - Bypass Breaker for System.
8. Open UIB1.
9. Open MOB1.
10. Verify that UPS1 is now completely OFFLINE.
11. Open UIB2.
12. Open MOB2.
13. Verify that UPS2 is now completely OFFLINE.

10.10 APM Procedure from Wrap-Around Bypass to Parallel Inverter Operation

Note: MBB is CLOSED.

1. Close UIB1 - Feed breaker to UPS1 (see **Figure 81**).
2. Close UIB2 - Feed breaker to UPS2.
3. Allow each UPS to qualify the Input and Bypass Feeds.
4. Close Battery Breaker(s) for UPS1.
5. Close Battery Breaker(s) for UPS2.
6. Close MOB1 - Output Breaker for UPS1.
7. Close MOB2 - Output Breaker for UPS2.
8. Verify that each UPS is now registering that it is in Static Bypass Mode and that the Battery Status Light is not lit.
9. Open MBB.
10. Both UPS units should now be in static bypass mode.
11. Engage the Inverter on UPS1.
12. Engage the Inverter on UPS2.
13. Verify that there is a successful transfer from Static Bypass to Inverter (Normal Mode).
14. UPS1 and UPS2 are now both ONLINE.

10.11 Parallel APM System Startup

1. Close circuit breakers UIB1 and UIB2.
2. Close the battery breaker for each UPS.
3. Verify that the APM units are operating in Normal Mode.
4. Close circuit breakers MOB1 and MOB2.
5. Close circuit breaker MIB.

10.12 Parallel APM System Shutdown

1. Shutdown connected loads.
2. Open circuit breaker MIB.
3. Open circuit breakers MOB1 and MOB2.
4. Open circuit breakers UIB1 and UIB2.
5. Open the battery breaker for each UPS.

10.13 Emergency Shutdown With EPO

This circuit has been designed to switch off the UPS in emergency conditions (i.e., fire, flood, etc.). The system will turn off the rectifier, inverter and stop powering the load immediately (including the inverter and bypass), and the battery stops charging or discharging.

If the input utility is present, the UPS's controls will remain active; however, the output will be turned off. To remove all power from the UPS, the external feeder breaker should be opened. (Refer to **Figure 67**).

10.14 Auto Restart

When the main and bypass sources fail, the UPS draws power from the battery system to supply the load until the batteries are depleted. When the UPS reaches its end of discharge (EOD) threshold, it will shut down.

The UPS will automatically restart and enable output power:

- after utility power is restored
- if “Auto Recovery after EOD Enabling” is enabled in the UPS configuration (set by factory or by Vertiv)
- after the “Auto Recovery after EOD Delay Time” expires (the default delay is 10 minutes)

During the auto recovery delay, the Liebert APM will be charging its batteries to provide a safety margin for equipment shutdown if input power fails again.

If the “Auto Recovery after EOD Enabling” feature is disabled, the system must be restarted manually.

10.15 Reset After Shutdown for Emergency Stop (EPO Action) or Other Conditions

Once all appropriate measures have been taken to correct the problem indicated by the alarm message appearing on the Operator Control Panel, carry out this procedure to restore the UPS to regular operation following an EPO action or for the following reasons: Inverter Overtemperature, Cut-off Overload, Battery Overvoltage, excessive switching (BYP: XFER COUNT BLOCK), etc.

When the user confirms that the fault is cleared:

1. Press the FAULT CLEAR button to let the system exit the emergency off state.
2. Press the INVERTER ON button on the right side of the Operator Control Panel for longer than 2 seconds (after the rectifier has qualified).



NOTE

The rectifier will start automatically 5 minutes after the of overtemperature fault is cleared.

After the EPO button is pressed, if the input utility is removed, the UPS will shut down completely. When input utility is restored, the EPO condition will clear, and the UPS will enable the static bypass and restore the output.

10.16 Battery Protection

10.16.1 Battery Undervoltage Warning

Before the end of discharge, the Liebert APM displays a low battery warning. After this warning, the battery has the capacity for 5 minutes discharging with full load (default time). The Liebert APM can be user-configured to display this warning from 3 to 60 minutes before end-of-discharge.

10.16.2 Battery End-of-Discharge (EOD) Protection

If the battery voltage is lower than the end-of-discharge voltage, the battery converter will be shut down.

10.17 Replacing Dust Filters

Installing the two dust filter sizes in a Liebert APM requires only a Phillips screwdriver. Each filter is held in place by a bracket on either side of each filter. Each UPS is shipped from the factory with two sets of washable and reusable dust filters. Refer to **12.3.2 - Air Filters** for details about filter maintenance.

To replace each filter:

1. Open the UPS front door and locate the filters on the back side of the front door (see **Figure 82**).
2. Remove one bracket and loosen the screw on the second bracket. The second bracket need not be removed.
3. Remove the dust filter to be replaced.
4. Insert the clean filter.
5. Reinstall the bracket, tightening the screw securely.
6. Tighten the screw on the second bracket.

Figure 82 Dust filter replacement

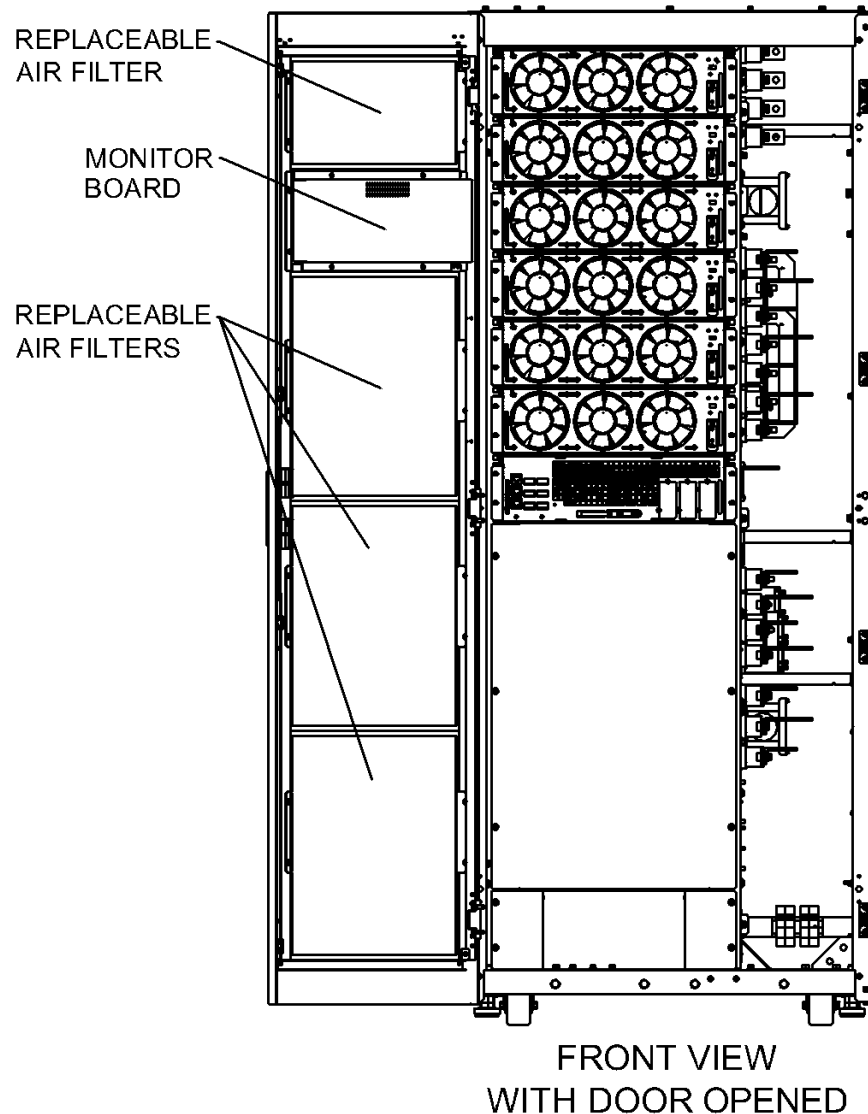

10.18 Operation

WARNING

Risk of electrical shock and arc flash. Can cause property damage, injury and death. The Liebert APM contains high voltages internally. Components that can only be accessed by opening the protective cover with tools cannot be serviced or replaced by the user.

Only properly trained and qualified service personnel are authorized to remove the protective covers.

The Liebert APM operates in the modes shown in **Table 31**. This section describes various kinds of operating procedures under each operating mode, including transfer between operating modes, UPS setting and procedures for turning on/off inverter.

Table 31 UPS operating modes

Operating mode		Descriptions
Normal mode	NORMAL	UPS powers the load
Bypass mode	BYPASS	The load power supply is provided by the static bypass. This mode can be regarded as a temporary transition mode between the normal mode and maintenance bypass mode, or a temporary abnormal operating status.
Maintenance Mode	MAINT	UPS shuts down, the load is connects to the mains through the Liebert BDC. In this mode the load is not protected against abnormal input utility power.

As shown in **Figure 83**, the AC utility source is supplied through the input breaker, and the rectifier converts the alternating current into DC power. The inverter converts the AC power from the utility—or DC power from the batteries—into AC power for the load. The batteries power the load through the inverter in the event of a power failure. The utility source can also power the load through the static bypass.

If maintenance or repair of the UPS is necessary, the load can be switched without interruption in service using the Liebert BDC.

Figure 83 Single module block diagram—Single input configuration with three-breaker Liebert BDC

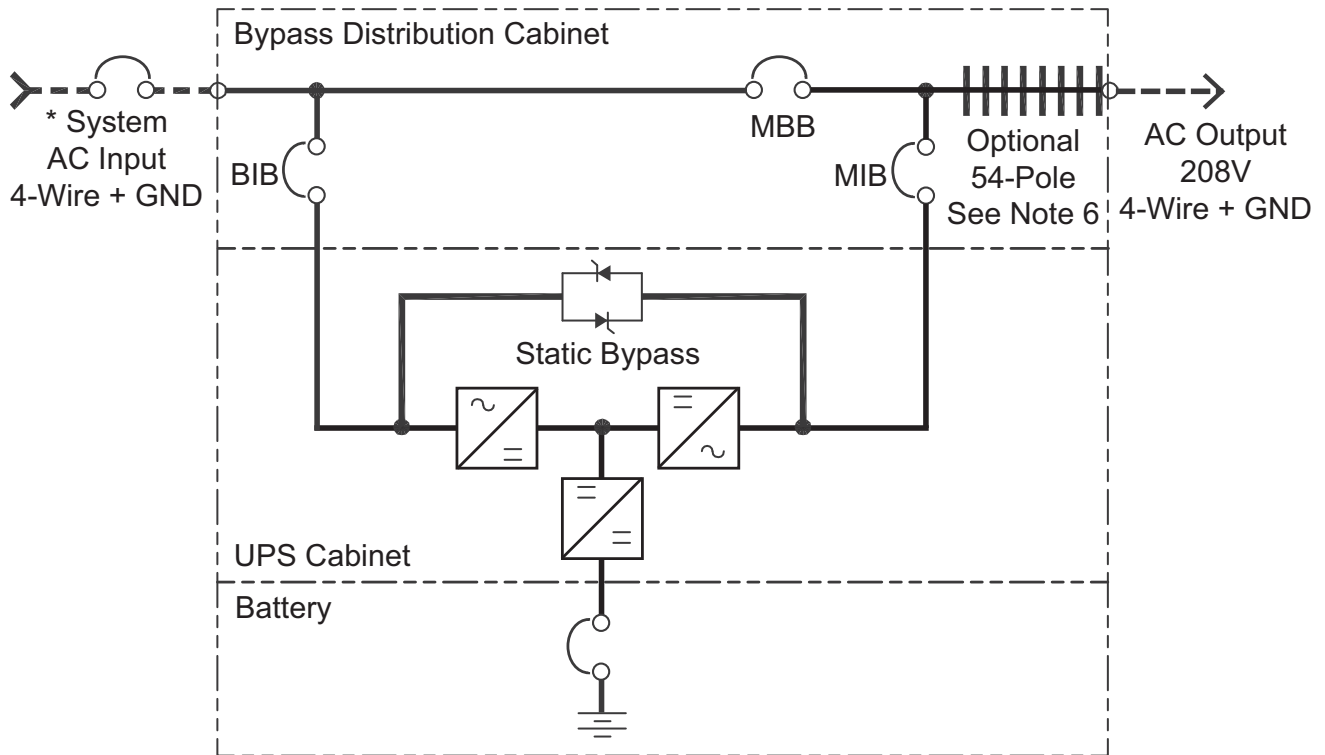

NOTES

1. Install in accordance with national and local electrical codes.
2. Input and bypass must share the same single source.
3. A neutral is required from the system AC input source. A full capacity neutral conductor is recommended. Grounding conductors are recommended.
4. UPS system input and output cables must be run in separate conduits.
5. Control wiring must be run in separate conduits.
6. Optional 54-pole, 225A for 45kVA frame only or optional 54-pole, 400A for 90kVA frame only.

BIB - Bypass Isolation Breaker
 MBB - Maintenance Bypass Breaker
 MIB - Maintenance Isolation Breaker
 * External Overcurrent Protection by others

----- Field-Supplied Wiring

UAM01003
 Rev. 2

Figure 84 Single module block diagram—Dual input configuration with three-breaker Liebert BDC

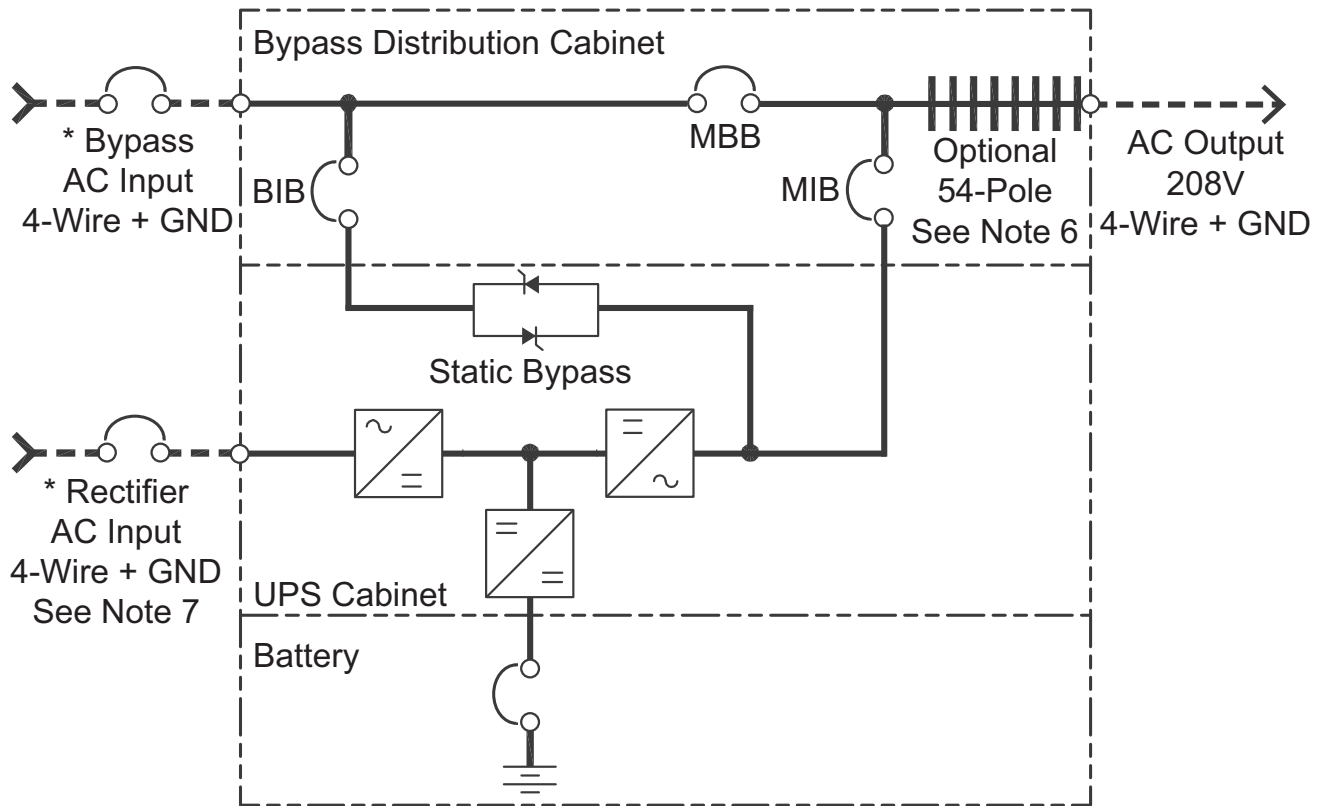

NOTES

1. Install in accordance with national and local electrical codes.
2. Input and bypass must share the same single source.
3. A neutral is required from the system AC input source. A full capacity neutral conductor is recommended. Grounding conductors are recommended.
4. Bypass and rectifier inputs and output cables must be run in separate conduits.
5. Control wiring must be run in separate conduits.
6. Optional 54-pole, 225A for 45kVA frame only or optional 54-pole, 400A for 90kVA frame only.
7. Customer must supply shunt trip breaker with 120V coil.

- BIB - Bypass Isolation Breaker
- MBB - Maintenance Bypass Breaker
- MIB - Maintenance Isolation Breaker
- * External Overcurrent Protection by others
- Field-Supplied Wiring

UAM01023
Rev. 3

Figure 85 Block diagram—Single input configuration with four-breaker internal bypass

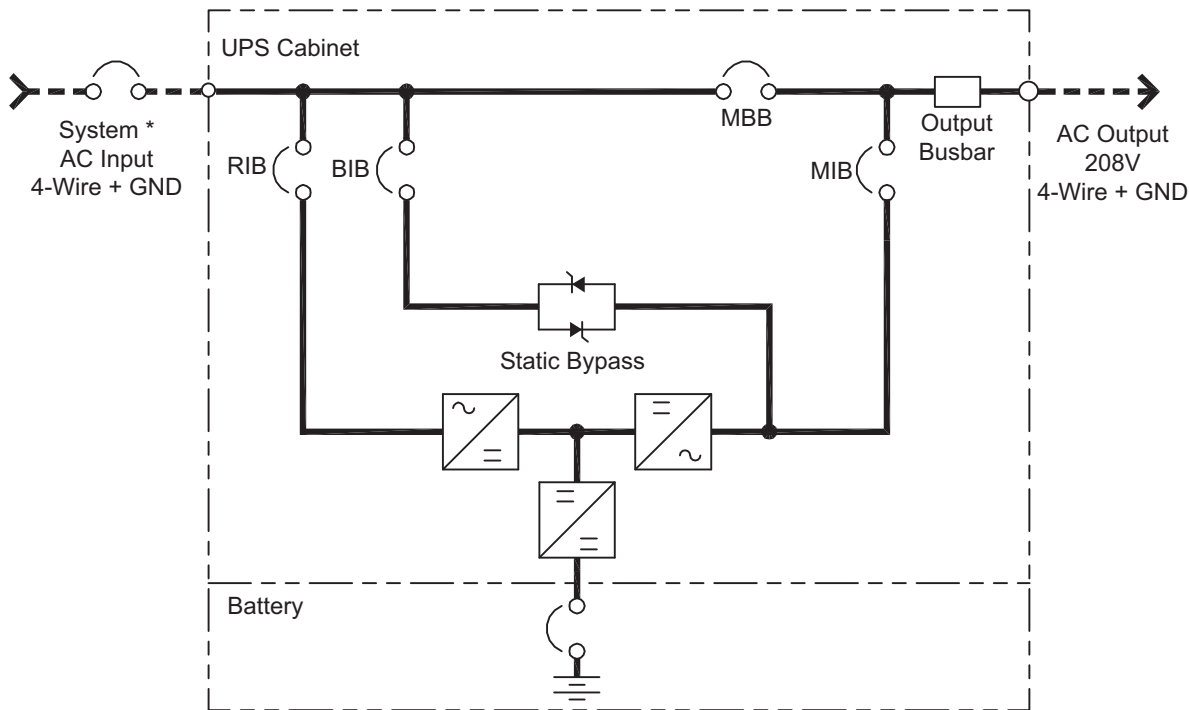

1. Install in accordance with national and local electrical codes.
2. A neutral is required from the system AC source. Vertiv recommends a full-capacity neutral conductor and grounding conductors.
3. System AC input and output cables must be run in separate conduits.
4. Control wiring must be run in separate conduits.

- RIB - Rectifier Input Breaker
- BIB - Bypass Isolation Breaker
- MBB - Maintenance Bypass Breaker
- MIB - Maintenance Isolation Breaker
- * External Overcurrent protection by others

--- Field-Supplied Wiring

UAM01070
Rev. 2

10.19 Static Bypass Switch

The circuit block labeled “Static Bypass” in **Figure 83** contains an electronically controlled switching circuit that enables the critical load to be connected to either the inverter output or to a bypass power source via the static bypass line. During normal system operation, the load is connected to the inverter and the inverter contactor is closed; but in the event of a UPS overload or inverter failure, the load is automatically transferred to the static bypass line.

To provide a clean (no-break) load transfer between the inverter output and static bypass line, the static switch activates, connecting the load to bypass. To achieve this, the inverter output and bypass supply must be fully synchronized during normal operating conditions. This is achieved through the inverter control electronics, which make the inverter frequency track that of the static bypass supply, provided that the bypass remains within an acceptable frequency window.



NOTE

When the UPS is operating in static bypass mode or on maintenance bypass, the connected equipment is not protected from power failures or surges and sags.

11.0 SPECIFICATIONS AND TECHNICAL DATA

11.1 Conformity and Standards

The Liebert APM has been designed to conform to the following standards:

Safety	UL 1778, CSA 22.2 107.3, 4th Edition
Surge	ANSI 62.41 Cat A3 and B3
Harmonics	IEC 61000-3-4
Electrical Fast Transient	IEC 61000-4-4 Level 4, Criteria A
ESD	IEC 61000-4-2 Level 4, Criteria A
FCC	Part 15, Class A
Radiated Immunity	IEC 61000-4-3 Level 3, Criteria A
Conducted Immunity	IEC 61000-4-6 Level 4, Criteria A
Low-Frequency Signals	IEC 61000-2-2 Criteria A
Transportation	ISTA Procedure 1H
ISO	9001
Misc	OSHA, ASME, NEMA PE-1

The Liebert APM has UL and c-UL approval.

11.2 UPS Environmental

The Liebert APM is designed to operate under the following environmental conditions without damage or degradation in electrical operating characteristics:

Table 32 Environmental requirements

Item	Requirements
Acoustical Noise, dBA, at 55 in. (1.4m)	57 (45kVA); 60 (90kVA)
With Top Fan Kit	69 (45kVA); 70 (90kVA)
Operating Altitude	3300 ft. (1000m) above sea level; derate power by 1% per 330 ft. (100m) between 3300 and 6000 ft. (1000m and 2000m)
Relative Humidity	0 to 95% non condensing
Operating Temperature, °F (°C)	32 to 104 (0 to 40)* Battery life is halved for every 18°F (10°C) increase above 68 (20)
UPS Storage/Transport Temperature, °F (°C)	-4 to 158 (-20 to 70)
Recommended Battery Storage Temperature, °F (°C)	-4 to 86 (-20 to 30) 68 (20) for optimum battery storage

Table 33 UPS mechanical characteristics

Rated Power, kVA	15 - 90
Dimensions, W x D x H, in (mm)	31-1/2 x 39-1/2 x 78-3/4 (800 x 1000 x 2000)
Weight, without batteries, lb (kg)	796 - 2154 (362 - 979)
Color	Black
Protection Degree IEC (60529)	IP20 (finger-proof with front doors open or closed)

Table 34 45kVA Liebert BDC mechanical characteristics

Rated Power, kVA	15-45
Dimensions, W x D x H, in (mm)	23-5/8 x 39-1/2 x 78-3/4 (600 x 1000 x 2000)
Weight, lb (kg)	
No Distribution	525 (239)
225A Panelboard	625 (284)
No Distribution & 480V Transformer	1070 (486)
No Distribution & 600V Transformer	1053 (479)
225A Panelboard & 480V Transformer	1170 (532)
225A Panelboard & 600V Transformer	1153 (524)
Color	Black
Protection Degree IEC (60529)	IP20 (finger-proof with front doors open or closed)

Table 35 90kVA Liebert BDC mechanical characteristics

Rated Power, kVA	15-90
Dimensions, W x D x H, in (mm)	23-5/8 x 39-1/2 x 78-3/4 (600 x 1000 x 2000)
Weight, lb (kg)	
No Distribution	550 (250)
Two 225A Subfeed Breakers	660 (300)
400A Panelboard	660 (300)
No Distribution & 480V Transformer	1405 (639)
No Distribution & 600V Transformer	1425 (648)
Two 225A Subfeed Breakers & 480V Transformer	1520 (691)
Two 225A Subfeed Breakers & 600V Transformer	1520 (691)
400A Panelboard & 480V Transformer	1520 (691)
400A Panelboard & 600V Transformer	1520 (691)
Color	Black
Protection Degree IEC (60529)	IP20 (finger-proof with front doors open or closed)

Table 36 600mm battery cabinet mechanical characteristics

Rated Power, kVA	15 - 90
Dimensions, W x D x H, in (mm)	23-5/8 x 39-1/2 x 78-3/4 (600 x 1000 x 2000)
Weight, lb (kg)	
with HX150 batteries	1490 (677)
with HX205 batteries	1755 (798)
with HX300 batteries	2213 (1006)
with HX330 batteries	2477 (1126)
Color	Black
Protection Degree IEC (60529)	IP20 (finger-proof with front doors open or closed)

Table 37 900mm battery cabinet mechanical characteristics

Rated Power, kVA	15 - 90
Dimensions, W x D x H, in (mm)	35-1/2 x 39-1/2 x 78-3/4 (900 x 1000 x 2000)
Weight, lb (kg)	
with HX400 batteries	2693 (1224)
with HX505 batteries	3245 (1475)
with HX540 batteries	3345 (1520)
Color	Black
Protection Degree IEC (60529)	IP20 (finger-proof with front doors open or closed)

11.3 Batteries Approved for Use in Liebert APM Systems

Table 38 Batteries approved for use in External Battery Cabinet, 600mm

Supplier	Part Number
Enersys	12HX150-FR
Enersys	12HX205-FR
Enersys	12HX300-FR
Enersys	12HX330-FR

Table 39 Batteries approved for use in External Battery Cabinet, 900mm

Supplier	Part Number
Enersys	12HX400-FR
Enersys	12HX505-FR
Enersys	12HX540-FR

Table 40 Internal batteries approved for use with 45kVA frame Liebert APM

Supplier	Part Number
Enersys	12HX100-FR
	12HX150-FR

11.4 UPS Electrical Characteristics

Refer to additional circuit breaker notes in **3.2.8 - Accessory Fuses and Backfeed Breaker Wiring**.



NOTE

The breakers and cables used must be in accordance with NEC ANSI/NFPA 70. A disconnect breaker must be provided for AC input, DC input and AC output. Recommended cable sizes are suitable for operation at a maximum temperature of 86°F (30°C). For continuous operation at temperatures above 86°F (30°C), the site design should include cables that meet requirements for 104°F (40°C) installations.

Table 41 UPS currents and terminals—Input (for single-input unit, 208V operation)

Unit Rating	Nominal Input Current	Maximum Input Current	OCP Device Rating	Bolt Size	Maximum Recommended Lug (T&B)			
					75°C Wire Current, tot	Wire	Compression Lug Two Hole 3/8" Bolt	Mechanical Lug Two Hole 3/8" Bolt
15	45	56	70	M10 (3/8")	130	(1) #1	54857BE	32209
30	90	112	125	M10 (3/8")	150	(1) 1/0	54860BE	32209
45	134	167	200	M10 (3/8")	200	(1) 3/0	54864BE	32211
60	179	223	250	M10 (3/8")	300	(2) 1/0	54860BE	32209
75	224	279	350	M10 (3/8")	350	(2) 2/0	54862BE	32209
90	268	334	400	M10 (3/8")	460	(2) 4/0	54866BE	32211

Table 42 UPS currents and terminals—Input (for dual-input unit only, 208V operation)

Unit Rating	Nominal Input Current	Maximum Input Current	OCP Device Rating	Bolt Size	Maximum Recommended Lug (T&B)			
					75°C Wire Current, tot	Wire	Compression Lug Two Hole 3/8" Bolt	Mechanical Lug Two Hole 3/8" Bolt
15	45	56	70	M10 (3/8")	130	(1) #1	54857BE	32209
30	90	112	125	M10 (3/8")	150	(1) 1/0	54860BE	32209
45	134	167	200	M10 (3/8")	200	(1) 3/0	54864BE	32211
60	179	223	250	M10 (3/8")	300	(2) 1/0	54860BE	32209
75	224	279	350	M10 (3/8")	350	(2) 2/0	54862BE	32209
90	268	334	400	M10 (3/8")	460	(2) 4/0	54866BE	32211

Table 43 UPS currents and terminals—Bypass input (for dual-input units, 208V operation)

Unit Rating	Nominal Input Current	OCP Device Rating	Bolt Size	75°C Wire Current, tot	Wire	Maximum Recommended Lug (T&B)	
						Compression Lug Two Hole 3/8" Bolt	Mechanical Lug Two Hole 3/8" Bolt
15	42	60	M10 (3/8")	130	(1) #1	54857BE	32209
30	84	110	M10 (3/8")	150	(1) 1/0	54860BE	32209
45	126	175	M10 (3/8")	175	(1) 2/0	54862BE	32209
60	168	225	M10 (3/8")	230	(1) 4/0	54866BE	32211
75	210	300	M10 (3/8")	300	(2) 1/0	54860BE	32209
90	252	350	M10 (3/8")	350	(2) 2/0	54862BE	32209

Table 44 UPS currents and terminals—Output 208V

Unit Rating	Nominal Output Current	OCP Device Rating	Bolt Size	75°C Wire Current, tot	Wire	Maximum Recommended Lug (T&B)	
						Compression Lug Two Hole 3/8" Bolt	Mechanical Lug Two Hole 3/8" Bolt
15	42	60	M10 (3/8")	130	(1) #1	54857BE	32209
30	83	125	M10 (3/8")	150	(1) 1/0	54860BE	32209
45	125	200	M10 (3/8")	175	(1) 2/0	54862BE	32209
60	167	225	M10 (3/8")	230	(1) 4/0	54866BE	32211
75	208	300	M10 (3/8")	300	(2) 1/0	54860BE	32209
90	250	350	M10 (3/8")	350	(2) 2/0	54862BE	32209

Table 45 UPS currents and terminals—Battery (288V string)

Unit Rating	Battery Current	OCP Device Rating	Bolt Size	75°C Wire Current, tot	Wire	Maximum Recommended Lug (T&B)	
						Compression Lug Two Hole 3/8" Bolt	Mechanical Lug Two Hole 3/8" Bolt
15	67	80	M10 (3/8")	130	(1) #1	54857BE	32209
30	135	150	M10 (3/8")	175	(1) 2/0	54862BE	32209
45	202	225	M10 (3/8")	230	(1) 4/0	54866BE	32211
60	269	300	M10 (3/8")	300	(2) 1/0	54860BE	32209
75	335	350	M10 (3/8")	400	(2) 3/0	54864BE	32211
90	404	450	M10 (3/8")	460	(2) 4/0	54866BE	32211

Table 46 AC/AC efficiency, loss and air exchange

AC/AC Efficiency	Data					
Normal Mode (dual conversion), %	94 maximum					
ECO Mode, %	Up 98					
Inverter Efficiency (DC/AC) (Battery at Nominal Voltage 288VDC and Full-Rated Linear Load)						
Rated Power, kVA	15-90					
Battery Mode, %	94					
Heat Losses and Air Exchange						
Rated Power, kVA	15	30	45	60	75	90
Normal Mode, kW	0.9	1.8	2.7	3.6	4.5	5.4
No Load, kW	0.3	0.6	0.9	1.2	1.5	1.8
Maximum forced air cooling (front intake, rear exhaust), L/sec (m ³ /hr)	102 (173)	204 (346)	306 (519)	408 (692)	510 (865)	612 (1038)
Heat Dissipation, BTU/Hr (kWh)						
Without Transformer	3074 (0.9)	6147 (1.8)	9220 (2.7)	12,295 (3.6)	15,368 (4.5)	18,442 (5.4)
With Transformer, 480V	8,530 (2.5)	11,600 (3.4)	19,545 (4.3)	22,178 (6.5)	25,249 (7.4)	28,320 (8.3)
With Transformer, 600V	8,530 (2.5)	11,600 (3.4)	19,545 (4.3)	21,837 (6.4)	24,908 (7.3)	27,978 (8.2)
With Transformer, 208V	8,189 (2.4)	11,260 (3.3)	14,330 (4.2)	21,837 (6.4)	24,908 (7.3)	27,978 (8.2)
Top Fan Forced Air Cooling, Total: 2 Fans	45kVA Frame - 566 L/sec (2040 m ³ /hr)					
	90kVA Frame - 744 L/sec (2680 m ³ /hr)					

Table 47 Rectifier input

Parameter	15-90kVA
Rated AC Input Voltage ¹	208/120V or 220/127V, 60Hz, 3-Phase, 4-Wire Plus Ground
Input Voltage Range, Startup/Operating	96-138V or 102-146V or -20%, +15% (Full Load)
Input Voltage Range, Operating	72-138V or 76-146V or -40%, +15% (<80% Load)
Frequency	50 or 60Hz (40-70Hz Range)
Power Factor	0.99 Full Load, 0.98 Half Load
THD	3% THDI Full Load

1. Three-phase, four-wire and shared neutral with the bypass input.

Table 48 Battery DC intermediate circuit

Parameter	15 - 90kVA							
Battery Bus Voltage	Nominal: 288VDC (VRLA Float charge is 324V) 24 jars of 12V VRLA							
Number of Lead-Acid Cells	144 = [24 x 6 cell (12V) blocks], nominal							
Float Voltage	2.25V/cell, selectable from 2.2 - 2.3V/cell Constant current and constant voltage charge mode							
Temperature Compensation	-3.0mV/°C, selectable from 0 to -5.0mV/°C around 77°F (25°C) or 86°F (30°C) or inhibit							
Ripple Voltage	£1%							
Ripple Current, ~ C ₁₀	£5%							
Boost Charge Voltage	2.35 V/cell (selectable from 2.30-2.40V/cell) Constant current and constant voltage charge mode							
Boost Control	<ul style="list-style-type: none"> • Float-boost current trigger 0.050 C10 (selectable 0.030-0.070) • Boost-float current trigger 0.010 C10 (selectable 0.005-0.025) 24 hr safety time-out (selectable 8-30 hr) Boost charge mode inhibit also selectable							
End of Discharge	1.63 V/cell (selectable from 1.60-1.750V/cell) Auto Inverse EOD voltage x discharge current mode (The end of discharge voltage increases at low discharge currents)							
Battery Charge	2.4 V/cell (selectable from 2.3-2.4V/cell) Constant current and constant voltage charge mode Programmable auto trigger or inhibit of boost mode							
Battery Charging Power ¹ Max Current (Adjustable) ²	UPS (kVA)	15	30	45	60	75	90	
	Battery Charging Power (kW)	2.25	4.5	6.75	9	11.25	13.25	
	Max Charging Current (A)	11	22	33	44	55	66	

1. At low input voltage, the UPS recharge capability increases with load decrease (up to the maximum capacity indicated).

2. Maximum currents listed are for end of discharge voltage of 1.67 V/cell for 144 cells.

Table 49 Inverter output to critical load

Parameter	15 - 90kVA
Rated AC Voltage ¹	208/120, 220/127VAC, 60Hz, 3-phase, 3- or 4-wire plus ground
Frequency ²	60Hz
Overload Capacity	110% load, 60 min 125% load, 10 min 150% load, 60 sec
Fault Current	Short circuit for 200 ms
Non-Linear Load Capability ³	100%
Neutral Current Capability	170%
Steady State Voltage Stability	±1% (balanced load)
Voltage Regulation	±1% for balanced load ±5% for 100% unbalanced load
Phase Balance	120° ±1° for balanced load 120° ±15°± for 100 unbalanced load
Transient Voltage Response ⁴	±5%
THD	< 1% (linear load), <4% (non linear load ³)
Sync Frequency Range	Rated frequency ± 2Hz (selectable ± 0.5 to ± 3Hz)
Frequency Slew Rate	0.2 to 3Hz/sec
Frequency Regulation	±0.1% (single Liebert FlexPower Assembly) ±0.25% (six Liebert FlexPower Assemblies)
Voltage Adjustment Range	-5% to +16% of nominal

1. Factory set to 208V or 220V selectable by commissioning engineer.
2. Factory set to 60Hz; 50Hz selectable by commissioning engineer. Frequency converter operation also selectable.
3. EN50091-3 (1.4.58) crest factor: 3:1
4. IEC62040-3/ EN 50091-3 also for 0-100-0% load transient. Transient recovery time: return to within 5% of steady state output voltage within half a cycle.
5. Three-phase, 4 wire and shared neutral with the bypass input.

Table 50 Bypass input

Parameter	15 - 90kVA	
Rated AC Voltage ¹²	208/220V 3-phase	
Rated current	208V	252A
	220V	240A
Overload	135% load, long term	
Upstream protection, bypass line	Thermomagnetic circuit-breaker, rated up to 125% of nominal output current. IEC 60947-2 curve C.	
Current rating of neutral cable, A	1.7×In	
Frequency, Hz	60	
Transfer time between Bypass and Inverter, ms	Synchronous transfer: 0ms Asynchronous transfer (default): 15 ms (50 Hz), 13.3 ms (60 Hz) or 40, 60, 80, 100 ms selectable	
Bypass voltage tolerance,%VAC	Upper limit: +10, +15 or +20, default +15 Lower limit: -10, -20, -30 or -40; default: -20 (delay time to accept steady bypass voltage: 10 sec)	
Bypass frequency tolerance,%	±10 or ±20; default ±10	
Synchronization - Window	Rated frequency ± 2Hz (selectable ± 0.5 to ± 3Hz)	

1. Factory-set to 208 or 220V selectable by commissioning engineer.
2. Three-phase, 4 wire and shared neutral with the rectifier input. Neutral referenced to the output.

Figure 86 Battery, circuit breaker and UPS wiring with external batteries with four connecting wires

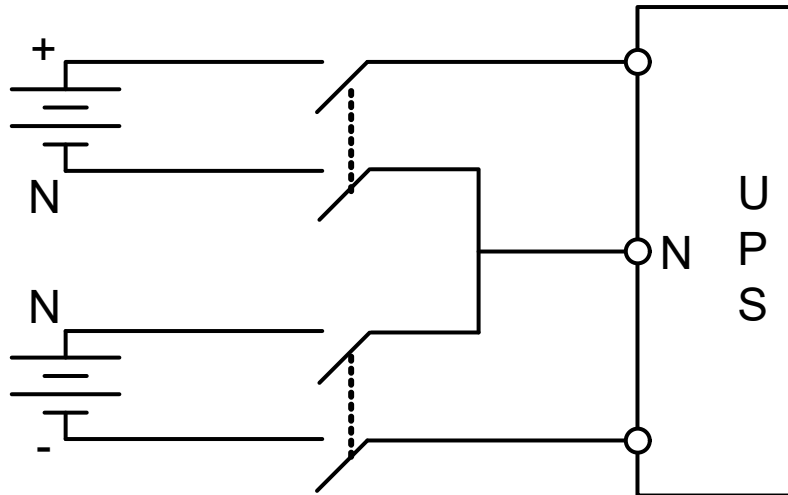
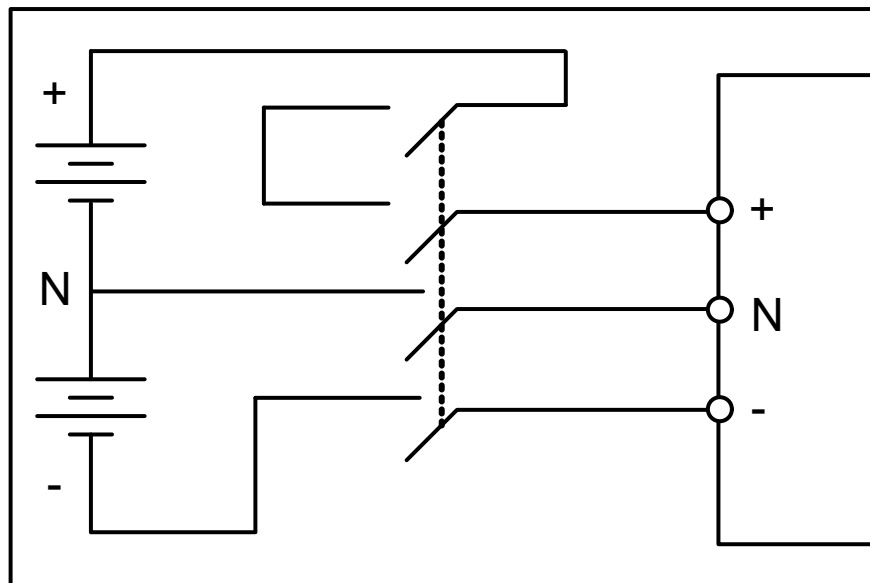

Figure 87 Battery, circuit breaker and UPS wiring with external batteries with three connecting wires



12.0 MAINTENANCE

12.1 Safety Precautions

Observe the safety precautions in **Important Safety Instructions on page 1**.

Only properly trained and qualified personnel should perform maintenance on the UPS system. Observe all of the warnings and cautions below before performing any maintenance on the UPS system and associated equipment. Also observe the manufacturer's safety precautions pertaining to the battery, along with the battery safety precautions in this section.

WARNING

Risk of electrical shock and arc flash. Can cause property damage, injury and death. Only Vertiv or Vertiv-trained service personnel should work on this equipment. Both AC and DC high voltages are present in lethal amounts within this equipment. Extreme care should be taken when working around UPS equipment. Always identify the source of connecting wiring prior to disconnecting. Mark any disconnected wires, so they can be properly reconnected. Do not substitute parts except as authorized by Vertiv. Maintain the UPS cabinets free of foreign materials such as solder, wire cuttings, etc. Call Vertiv if you are not sure of the procedures to follow or if you are not familiar with the design or operation of the equipment.

WARNING

Risk of electrical shock and arc flash. Can cause property damage, injury and death. Extreme caution is required when performing maintenance. Be constantly aware that the UPS system contains high DC as well as AC voltages. With input power off and the battery disconnected, high voltage at filter capacitors and power circuits should be discharged within 30 seconds. However, if a power circuit failure has occurred, you should assume that high voltage may still exist after shutdown. Check with a voltmeter before making contact. AC voltage will remain on the bypass and output contactors and the static bypass switch, unless associated external circuit breakers are opened. Check for voltage with both AC and DC voltmeters prior to making contact. When the UPS system is under power, both the operator and any test equipment must be isolated from direct contact with earth ground and the UPS chassis frame by using rubber mats. Some components within the cabinets are not connected to chassis ground. Any contact between floating circuits and the chassis is a lethal shock hazard. Use differential oscilloscopes when measuring a floating circuit. The differential input should have at least 800 vrms common mode input rating and a common mode rejection ratio of at least 80db. Exercise caution that the test instrument exterior does not make contact either physically or electrically with earth ground. In case of fire involving electrical equipment, use only carbon dioxide fire extinguishers, or others approved for use in electrical fire fighting.

12.2 Limited Life Components

The Liebert APM UPS has a design life well in excess of 10 years. Well-maintained units can continue to provide economic benefits for 20 years or more. Long-life components are used in the UPS wherever practical and cost-effective. However, due to the currently available component material, manufacturing technology limitations and the general function and use of the component, a few components in your Liebert UPS will have a shorter life cycle and require replacement in less than 10 years.

The following components utilized in your UPS system have a limited life cycle and are specifically exempt from warranty. To prevent a wear-out failure of one of these components affecting your critical load operations, Liebert recommends these components be periodically inspected and replaced before the expected expiration of their life cycle. The expected life of each component listed below is simply an estimate and is not a guarantee. Individual users may have site-specific requirements, maintenance and other environmental conditions that affect the length of the component's useful life cycle.

Table 51 Component service life

Component	Expected Life	Replace in:
Air filters	5 years	Check four times per year
Valve-regulated, lead-acid (VRLA)	5 to 8 years	3 to 4 years

In most cases, replacement components must exactly match the original component specifications. These replacement components are not readily available from third-party component distributors. For assistance with your specific component specifications, replacement component selection and sourcing, call 1-800-543-2378. For customers using Vertiv' preventive maintenance services, periodic inspection of these components is part of this service, as well as recommending component replacement intervals to customers to avoid unanticipated interruptions in critical load operations.

12.3 Routine Maintenance

Become thoroughly familiar with the equipment, but at no time go beyond the specific procedures in this manual while performing maintenance or correcting a malfunction. If you have any doubt as to what must be done, call Vertiv at 1-800-543-2378 for further instructions. The UPS is designed for unattended operation, but does require some common sense maintenance.

- Keep good records—Troubleshooting is easier if you maintain historical service records.
- Keep the UPS free of dust and any moisture.
- Keep the UPS cool:
 - Battery systems must be kept in the range of 72-77°F (22-25°C) in order to meet design specifications for capacity and longevity.
 - The UPS will reliably meet all performance specifications at temperatures up to 104°F (40°C), and can be slightly derated for operation at even higher temperatures. However, performance and longevity will be optimized when the UPS is operated at the same temperature as the batteries.
- Keep connections tight.
- Tighten all connections at installation and at least annually thereafter. (See **12.3.5 - Torque Requirements**).

12.3.1 Record Log

Set up a maintenance log to record scheduled checks and any abnormal conditions.

The log should have space for all metered data including phase readings, alarm messages, UPS mode of operation, air filter replacement date, and observation notes. A second log should be maintained for the battery module as directed by the battery manufacturer.

Vertiv recommends a periodic walk-through inspection of the UPS and battery rooms to check for visible and audible indications of problems. Log the inspection, metered parameter indications and any discrepancies.

12.3.2 Air Filters

The air filters must be inspected and serviced on a regular schedule. The period between inspections will depend upon environmental conditions. Under normal conditions, the air filters will require cleaning or replacement approximately every two months.

All Liebert APM models have replaceable filter elements behind the grille in the front of the unit. This element can be changed with the UPS operating, by opening the outer door for access. The Liebert APM air filters are washable and reusable. Two sets of air filters are shipped with the Liebert APM.

Abnormal or dusty conditions will require more frequent cleaning and replacement of air filters. Inspect installations in new buildings more often, then extend the inspection period as experience dictates.

12.3.3 Battery Maintenance



WARNING

Risk of electrical shock and arc flash. Can cause property damage, injury and death. These maintenance procedures will expose hazardous live parts. Refer servicing to qualified personnel.

12.3.4 Battery Safety Precautions

Servicing of batteries should be performed or supervised by personnel experienced with batteries and the required precautions. Keep unauthorized personnel away from batteries.

When replacing batteries, use the same number and type of batteries.

WARNING

Risk of electric shock, explosive reaction, hazardous chemicals and fire. Can cause property damage, injury and death.

Lead-acid batteries contain hazardous materials. Batteries must be handled, transported, and recycled or discarded in accordance with federal, state, and local regulations. Because lead is a toxic substance, lead-acid batteries should be recycled rather than discarded.

Do not dispose of battery or batteries in a fire. The battery may explode.

Do not open or mutilate the battery or batteries. Released electrolyte is harmful to the skin and eyes. It is poisonous.

A battery can present a risk of electrical shock and high short circuit current. The following precautions should be observed when working on batteries:

- Remove watches, rings and other metal objects.
- Use tools with insulated handles.
- Wear rubber gloves and boots.
- Do not lay tools or metal parts on top of batteries.
- Disconnect charging source prior to connecting or disconnecting battery terminals.
- Determine if battery is inadvertently grounded. If inadvertently grounded, remove source of ground. Contact with any part of a grounded battery can result in electrical shock. The likelihood of such shock will be reduced if such grounds are removed during installation and maintenance.
- Lead-acid batteries can present a risk of fire because they generate hydrogen gas. In addition, the electrical connections must be protected against accidental short circuits which can cause sparks. The following procedures should be followed:
- DO NOT SMOKE when near batteries.
- DO NOT cause flame or spark in battery area.
- Discharge static electricity from body before touching batteries by first touching a grounded metal surface.
- After replacing battery jars in a battery cabinet, replace the retaining straps that hold the jars in place on the shelves. This will limit accidental movement of the jars and connectors should the cabinet ever need to be repositioned or relocated.

Regular maintenance of the battery module is an absolute necessity. Periodic inspections of battery and terminal voltages, specific gravity, and connection resistance should be made. Strictly follow the procedures outlined in the battery manufacturer's manual. (See battery manufacturer's web site.)

Valve-regulated lead-acid batteries do require periodic maintenance. Although they do not require maintenance of electrolyte levels, visual inspections and checks of battery voltage and connection resistance should be made.

NOTICE

Do not use cleaners on the batteries. Solvents can make the battery cases brittle. Use only a dry cloth or a cloth moistened in water

Since individual battery characteristics are not identical and may change over time, the UPS module is equipped with circuitry to equalize battery cell voltages. This circuit temporarily increases charging voltage to maintain flooded type battery cells at full capacity.



WARNING

Risk of electric shock, explosive reaction, hazardous chemicals and fire. Can cause equipment damage, personal injury and death.

Do not use equalize charging with valve-regulated, lead-acid batteries, such as those used in Liebert battery cabinets. Refer to the battery manufacturer's manual, available on the manufacturer's Web site, for specific information about equalize charging.

Table 52 Battery voltage record

Date	Float Voltage (Volts DC)	Nominal Voltage (Volts DC)	Ambient Temp. (°F)

* To be completed by Vertiv engineer at time of startup.

12.3.5 Torque Requirements

All electrical connections must be tight. Refer to **Table 18** and **Figure 60**.

Tables 53 and **54** provide the torque values for the connections in the UPS and batteries. Use these values unless the equipment is labeled otherwise.

Table 53 Terminal block with compression lugs (for control wiring)

AWG Wire Size or Range	Lb-in	Nm
#22 - #14	3.5 to 5.3	0.4 to 0.6

Table 54 Battery retorquer values

Battery Mfr.	Battery Model #	Retorque Value
Energys	12HX100-FR	40 in-lb (4.5N-m)
	12HX150FR	40 in-lb (4.5N-m)
	12HX205-FR	58 in-lb (6.5N-m)
	12HX300-FR	58 in-lb (6.5N-m)
	12HX330-FR	58 in-lb (6.5N-m)
	12HX400-FR	58 in-lb (6.5N-m)
	12HX505-FR	58 in-lb (6.5N-m)
	12HX540-FR	58 in-lb (6.5N-m)

12.4 Detecting Trouble

It is important that the operator check the instrument readings if abnormal equipment performance is suspected. Any metered value that differs appreciably from normal could mean an impending malfunction, and should be investigated.

Items to check on the various UPS display screens include:

1. Output voltage of all phases should be within 2% of normal voltage. Output currents on each phase should not normally differ by more than 20%. If a greater difference is noted, the load is unbalanced and corrective action should be taken to redistribute the load, if possible.
2. If the UPS has not operated on battery power during the last 10 hours, the batteries should require little charging current. Battery mimic should indicate normal DC voltage with relatively little battery charge current.
3. Input current on each phase should be within 10% of the average input current. Alarm messages indicate malfunction or impending malfunction. A daily check of the Operator Control Panel will help to provide an early detection of problems. Refer to **Appendix B - - UPS Status Messages** to interpret alarm messages.
4. Tracing a problem to a particular section is facilitated by alarm messages and the metered parameter indications. These are stored in the Status Reports and can be displayed at the Operator Control Panel or at an optional terminal.



NOTE

If the UPS system has a blown fuse, the cause should be determined before you replace the fuse. Contact Vertiv.

12.5 Reporting a Problem

If a problem occurs within the UPS, review all alarm messages along with other pertinent data. This information should be given via telephone to the Liebert Service dispatcher. This information can also be automatically sent by telephone modem. Call 1-800-543-2378 to report a problem or to request assistance.

12.6 Corrective Actions

For each alarm message on the Operator Control Panel and the Remote Alarm Status Panel, you can find the recommended corrective action in **Appendix B - - UPS Status Messages**.

12.7 Recommended Test Equipment

A list of recommended test equipment and tools required to maintain, troubleshoot, and repair the UPS module is given in **Table 55**. You may substitute instruments of equivalent range and accuracy. All instruments should be calibrated and be within the current calibration cycle. Calibration data for the instruments should be maintained in equipment-history files and the instruments labeled for audit and verification.

Table 55 Recommended test equipment and tools

Qty	Test Equipment	Manufacturer	Model or Type
1	Oscilloscope	Tektronix, H-P or Fluke	DC to 50 MHz
2	Voltage Probes	Tektronix, H-P or Fluke	10X, with 10 ft. Cable
2	Voltage Probes	Tektronix, H-P or Fluke	100X, with 10 ft. Cable
1	Digital Multi-meter	Fluke	8060, with Test Leads
1	Tool Kit	N/A	Standard electrical contractor tools

APPENDIX A - HAZARDOUS SUBSTANCES OR ELEMENTS ANNOUNCEMENT

Table 56 Hazardous substances or elements

Part Name	Hazardous Substances					
	Lead (Pb)	Mercury (Hg)	Cadmium (Cd)	Chrome (Cr ⁶⁺)	Polybrominated Biphenyl (PBB)	Polybrominated Diphenyl Ethers (PBDE)
Hex copper stud	X	4	4	4	4	4
PCBA	X	4	4	4	4	4
AC capacitor	X	4	4	4	4	4
DC capacitor	X	4	4	4	4	4
Fan	X	4	4	4	4	4
Cables	X	4	4	4	4	4
LCD	X	X	4	4	4	4
Sensors	X	4	4	4	4	4
Large-medium power magnetic components	X	4	4	4	4	4
Circuit breaker / rotating switch	X	4	4	4	4	4
Semiconductors	X	4	4	4	4	4
Battery (when applicable)	X	4	4	4	4	4
Insulation monitoring device (when applicable)	X	4	4	4	4	X

4 =Means the content of the hazardous substances in all the average quality materials of the part is within the limits specified in SJ/T-11363-2006

X =Means the content of the hazardous substances in at least one of the average quality materials of the part is outside the limits specified in SJ/T11363-2006

Vertiv is committed to the design and manufacturing of environment-friendly products. It will reduce and eventually eliminate the hazardous substances in the products through unremitting efforts in research. However, limited by the current technical level, the following parts still contain hazardous substances due to the lack of reliable substitute or mature solution:

1. All solders in the products contain lead.
2. Copper alloy contains lead.
3. Backlight bulb contains mercury.
4. The ceramic materials of the ceramic capacitor, the copper terminals and copper leads of metallic film capacity contain lead.
5. The glass of resistor contains lead.
6. The glass of LCD contains lead, and the backlight lamp contains mercury.
7. The lead in the battery is determined by the battery feature and technical levels.
8. The insulation monitoring device contains lead and PBDE.

About Environment Protection Period: The Environment Protection Period of the product is marked on the product. Under normal working conditions and normal use of the products observing relevant safety precautions, the hazardous substances in the product will not seriously affect the environment, human safety or property in the Environment Protection Period starting from the manufacturing date.

About battery: The battery life is dependent on the ambient temperature and charging / discharging times. The battery life will be shortened if the battery is used under high temperature or in deep discharging status. Refer to the manufacturer's product literature for details.

Applicable scope: Liebert APM 90kVA UPS

APPENDIX B - UPS STATUS MESSAGES

Table 57 shows all event messages as they appear in the current status area of the LCD or the history log, along with a description and recommended actions, if any. For further information on the current status area and the history log, see **9.10 - UPS History Log**.

Table 57 UPS status messages

Event Message	Description / Suggested Action (if any)
Comm. Fail	The CAN communication between internal monitor and rectifier/inverter/bypass fails. Contact Vertiv at 800-543-2378 for assistance.
Battery Overtemp.	The Battery temperature is over limit. Check the battery temperature and ventilation.
Ambient Overtemp.	The Ambient temperature is over limit. Check the ventilation of UPS room.
Replace Battery	Battery should be replaced. Contact Vertiv at 800-543-2378 for assistance.
Battery Low Pre-warning	Before the end of discharging, battery under-voltage pre-warning should occur. After this pre-warning, battery should have the capacity for 3 minutes discharging with full load. The time is user configured from 3 to 60 minutes. Shut down the load in time.
Battery End of Discharge	Inverter turned off due to low battery voltage. Check the utility failure and try to fix it.
Mains Volt. Abnormal	Mains Voltage exceeds the upper or lower limit and results in rectifier shutdown. Check the input line-to-neutral voltage amplitude of rectifier.
Mains Undervoltage	Mains Voltage is undervoltage (120v~132V). Check the input line-to-line voltage amplitude of rectifier.
Mains Freq. Abnormal	Mains frequency is out of limit range and results in rectifier shutdown. Check the rectifier's input voltage frequency.
Rectifier Fault	Rectifier Fault; Contact Vertiv at 800-543-2378 for assistance.
Rectifier Overtemp.	The temperature of heat sink is too high to keep the rectifier running. The UPS can recover automatically. Check the environment and ventilation.
Charger Fault	The Charger has failed. Contact Vertiv at 800-543-2378 for assistance.
Input Fuse Fail	Input fuse is open. Contact Vertiv at 800-543-2378 for assistance.
Control Power 1 Fail	Control Power 1 has failed or has been lost. Contact Vertiv at 800-543-2378 for assistance.
Mains Phase Reversed	Input phase sequence is reversed. Contact Vertiv at 800-543-2378 for assistance.
Soft Start Fail	Rectifier could not start due to low DC bus voltage. Contact Vertiv at 800-543-2378 for assistance.
Bypass Unable to Trace	This alarm is triggered by an inverter software routine when the amplitude or frequency of bypass voltage is beyond the normal range. The amplitude threshold is fixed for positive and negative 10% rating. This alarm automatically resets once the bypass voltage goes normal. <ol style="list-style-type: none"> 1. First verify that the bypass voltage and frequency displayed on the panel is within the selected range. Note here the rated voltage and frequency are specified by "Output voltage level" and "Output frequency level" respectively. 2. If the displayed voltage is believed to be abnormal, then verify the bypass voltage and frequency presented to the UPS. Check the external supply if it is found to be faulty. Contact Vertiv at 800-543-2378 for assistance.

Table 57 UPS status messages (continued)

Event Message	Description / Suggested Action (if any)
Bypass Abnormal	<p>This alarm is triggered by an inverter software routine when the amplitude or frequency of bypass voltage exceeds the limit. This alarm automatically resets once the bypass voltage goes normal. First check if there are some relevant alarms such as “Bypass disconnect open”, “Bypass phase reverse” and “Mains neutral lost”. If they appear, solve them first.</p> <ol style="list-style-type: none"> 1. Then verify that the bypass voltage and frequency displayed on the panel is within the bypass limit. Note here the rated voltage and frequency are specified by “Output voltage level” and “Output frequency level” respectively. 2. If the displayed voltage is believed to be abnormal, then verify the bypass voltage and frequency presented to the UPS. Check the external bypass supply if it is found to be faulty. If the utility is likely to trigger this alarm frequently, the bypass limit can be changed a little larger through the configuration software according to the customer’s agreement. <p>Contact Vertiv at 800-543-2378 for assistance.</p>
Inverter Asynchronous	<p>This alarm is triggered by an inverter software routine when the inverter and bypass waveforms are misaligned by more than 6 degrees in phase. This alarm resets automatically once the condition is no longer true.</p> <ol style="list-style-type: none"> 1. First check if the alarm “Bypass unable to trace” or “Bypass abnormal” occurs. If so, solve it first. 2. Verify the waveform of the bypass voltage. If it is too distorted, ask the customer to verify and seek any possible measurements. <p>Contact Vertiv at 800-543-2378 for assistance.</p>
Inverter Fault	<p>This alarm indicates a fault condition exists within the inverter. Contact Vertiv at 800-543-2378 for assistance.</p>
Fan Fault	<p>At least one of the cooling fans failed. Contact Vertiv at 800-543-2378 for assistance.</p>
Inverter STS (relay) Fail	<p>At least one of the static switches of inverter side is open or short circuit. This fault is locked until power off. Contact Vertiv for assistance at 800-543-2378 for assistance.</p>
Bypass STS Fail	<p>At least one of the static switches of bypass side is open or short circuit. This fault is locked until power off. Contact Vertiv at 800-543-2378 for assistance.</p>
Output Fuse Fail	<p>At least one of the output fuses is open. Contact Vertiv at 800-543-2378 for assistance.</p>
Control Power 2 Fail	<p>Control Power 2 is abnormal or lost. Contact Vertiv at 800-543-2378 for assistance.</p>
Unit Overload	<p>The UPS is confirmed to be overload when the load arises above 105% nominal rating. The alarm automatically resets once the overload condition is removed.</p> <ol style="list-style-type: none"> 1. Confirm that the alarm is true by checking the load percent indicated on the LCD panel to determine which phase is being overloaded. 2. If the alarm is true, measure the actual output current to verify that the indications are valid. Disconnect unnecessary load and ensure the safety. In a parallel system, a severe load sharing error can also leads to the alarm. <p>Contact Vertiv at 800-543-2378 for assistance.</p>
System Overload	<p>The UPS parallel system is confirmed to overload when the total load arises above 105% nominal rating for the set basic number of UPSs. The alarm automatically resets once the overload condition is removed.</p> <ol style="list-style-type: none"> 1. Confirm that the alarm is true by checking the system load percent indicated on the LCD panel to determine which phase is being overloaded. 2. If the alarm is true, measure the actual output current to verify that the indications are valid. Disconnect unnecessary load and ensure the safety. In a parallel system, a severe load sharing error can also leads to the alarm.

Table 57 UPS status messages (continued)

Event Message	Description / Suggested Action (if any)
Unit Overload Timeout	<p>The UPS is confirmed to overload and the overload times out.</p> <p>Note 1: The highest loaded phase will indicate overload timing-out first.</p> <p>Note 2: When the timer is active, then alarm “unit overload” should also be active as the load is above nominal.</p> <p>Note 3: When the timer has expired, the inverter Static Switch is opened and the load transferred to bypass. The inverter shutdown and will restart after 10 seconds.</p> <p>Note 4: If the load decreases lower than 95% after 5 minutes, the system will transfer back to inverter mode.</p> <p>Confirm that the alarm is genuine by checking the load percent indicated on the LCD. If an overload is indicated then check the load, and investigate any additional load connected prior to the alarm (if applicable).</p>
Bypass Phase Reversed	<p>The phase sequence direction of bypass voltage is reversed.</p> <p>Normally, the phase of Phase B lags 120 degrees behind Phase A, and the phase of Phase C lags 120 degrees behind Phase B.</p> <p>Verify that the phase rotation of the bypass supply presented to the UPS is correct, and rectify it if it is found to be in error. Contact Vertiv at 800-543-2378 for assistance.</p>
Load Impact Transfer	<p>A transfer to bypass occurred due to a large step load. The UPS should recover automatically. Turn on connected equipment in sequential order to reduce the step loading of the inverter.</p>
Transfer Timeout	<p>The load is on bypass power due to excessive number of transfers that occurred within the last hour.</p> <p>The UPS will recover automatically and will transfer the load back to inverter power within an hour.</p>
Load Sharing Fault	<p>UPS working within a parallel system are not sharing load current correctly. Contact Vertiv at 800-543-2378 for assistance.</p>
DC Bus Abnormal	<p>Shut off inverter due to abnormal DC bus voltage.</p> <p>Contact Vertiv at 800-543-2378 for assistance.</p>
System Transfer	<p>The whole paralleled UPS system transferred to bypass at the same time. This message will appear on the UPS which passive transfer to bypass.</p>
DC Bus Overvoltage	<p>Rectifier, inverter and battery converter were shutdown because DC bus voltage is too high. Check whether there is a fault in rectifier side. If no, then check whether overload occurs. Restart the inverter after resetting the fault. If fault does not clear, contact Vertiv at 800-543-2378 for assistance.</p>
LBS Active	<p>The LBS setting is active. The UPS is acting as an LBS master or slave in a dual bus configuration.</p>
Battery ground fault	<p>Battery ground fault from dry contact signal. Contact Vertiv at 800-543-2378 for assistance.</p>
Inverter turned On manually	<p>Manual Turn On via front panel</p>
Inverter turned Off manually	<p>Manual Turn Off via front panel</p>
EPO	<p>Emergency Power Off</p>
Transfer Confirm	<p>Interrupted Transfer Confirm</p>
Transfer Cancel	<p>Interrupted Transfer is cancel</p>
Unit Off Confirm	<p>Unit Turned Off Confirm</p>
System Off Confirm	<p>System Turned Off Confirm</p>
Fault Reset	<p>Fault Reset</p>
Alarm Silence	<p>Alarm Silence</p>
Turn On Fail	<p>Turn On Fail</p>
Alarm Reset	<p>Audible Alarm Reset</p>
Bypass Mode	<p>UPS in Bypass Mode</p>
Normal Mode	<p>UPS in Normal Mode</p>

Table 57 UPS status messages (continued)

Event Message	Description / Suggested Action (if any)
Battery Mode	UPS in Battery Mode
Output Disabled	UPS Output Disabled
Maint. Disconnect Closed	Maintenance Disconnect Closed
Reserved	
Output Disconnect Open	Output Disconnect Open
Battery Reverse	Connect the battery again and check the wiring of batteries.
No Battery	Check the battery and the wiring of batteries.
Auto start	After UPS was shutdown at EOD, inverter auto starts when utility is restored.
BCB closed	BCB closed from dry contact signal.
BCB open	BCB open from dry contact signal.
Battery Float Charging	Battery is float charging.
Battery Boost Charging	Battery is boost charging.
Battery Discharging	Battery is discharging.
Battery Period Testing	Battery is period self-testing.
Batt. Capacity Testing	Battery is capacity self-testing.
Batt. Maint. Testing	Battery is maintenance self-testing.
Inverter in Setting	Inverter is in parameter setting.
Rectifier in Setting	Rectifier is in parameter setting.
Batt. Converter Fault	Battery converter output voltage beyond limits or battery fuse failed. Battery converter shuts down. Battery backup not available.
Operation Invalid	This record is registered following an incorrect operation.
Byp. Abnormal Shutdown	Both bypass and inverter voltages unavailable. Load interruption.
Mains Neutral Lost	AC Input mains reference neutral not detected.
Battery Room Alarm	Environment in battery room needs attention.
Rec Flash Update	Rectifier firmware is being updated.
Inv Flash Update	Inverter firmware is being updated.
Monitor Flash Update	Monitor firmware is being updated.
LBS abnormal	LBS is abnormal.

NOTE





VertivCo.com | Vertiv Headquarters, 1050 Dearborn Drive, Columbus, OH, 43085, USA

© 2019 Vertiv Co. All rights reserved. Vertiv and the Vertiv logo are trademarks or registered trademarks of Vertiv Co. All other names and logos referred to are trade names, trademarks or registered trademarks of their respective owners. While every precaution has been taken to ensure accuracy and completeness herein, Vertiv Co. assumes no responsibility, and disclaims all liability, for damages resulting from use of this information or for any errors or omissions. Specifications are subject to change without notice.

SL-25615_REV13/590-2064-501B