

READ THIS FIRST



Models G0446, G0539,
& G0571

*****IMPORTANT UPDATE*****

For Machines Mfd. Since January, 2014
and Owner's Manual Revised May, 2005

For questions or help with this product contact Tech Support at (570) 546-9663 or techsupport@grizzly.com

The following changes were made to this machine since the owner's manual was printed:

- Obtained CSA certification meeting CSA C22.2 #105-1953 and UL 987-7th standards.
- Changed transformer, contactors, overload relays, terminal blocks, and wiring.
- Changed circuit requirements.
- Replaced oscillation diaphragm assembly with an air cylinder.

Note: At the top of each page is a note that indicates which page it replaces in the original manual. On the parts list, the new parts are designated with a "V2" or "V3".

Aside from this information, all other content in the owner's manual applies and **MUST** be read and understood for your own safety. **IMPORTANT: Keep this update with the owner's manual for future reference.** For questions or help, contact our Tech Support at (570) 546-9663 or techsupport@grizzly.com.

Electrical Parts List (Replaces Page 47)

REF	PART #	DESCRIPTION
1	P05398101	ELECTRICAL CONTROL BOX
2	P05398102	HINGE
3	P05398103	DOOR
4	P05398104	BASE PLATE
5	PN05	HEX NUT 1/4-20
6	PLW02	LOCK WASHER 1/4
7	P05398107	CONTROL PANEL
8	PS07M	PHLP HD SCR M4-.7 X 8
9	P0539009	CURRENT SENSOR
10V2	P0539010V2	TRANSFORMER V2.03.10 (G0539/G0446)
11V2	P0571011V2	CONTACTOR SCHN LC1D50A V2.09.10 (G0571)
11V2	P0539011V2	CONTACTOR SCHN LC1D40A V2.09.10 (G0539/G0446)
12V3	P0539012V3	OL RELAY SCHN LRD340 30-40A V3.04.13 (G0539/G0446)
13V2	P0539013V2	FUSE 4A V2.03.10
14	P05718114	OL RELAY SCHN LR3D12 5.5-8A (G0571)
14	P05398114	OL RELAY SCHN LR3D08 2.5-4A (G0539/G0446)

REF	PART #	DESCRIPTION
15	P05398115	CONTACTOR SCHN LC1D09 220V
15-1	P05398115-1	CONTACTOR 2-PC ASSY LC1D09
16V2	P0571016V2	POWER TERMINAL BLOCK (G0571)
16V2	P05398116V2	POWER TERMINAL BLOCK (G0539/G0446)
18V2	P0571018V2	TERMINAL BLOCK (G0571)
18V2	P05398118V2	TERMINAL BLOCK (G0539/G0446)
19	PW06	FLAT WASHER 1/4
20	PLW02	LOCK WASHER 1/4
21	PS04	PHLP HD SCR 1/4-20 X 1/2
22	P05398122	PU CONNECTOR 1/2
23	P05398123	PU CONNECTOR 3/4
24	P05398124	CABLE CONNECTOR 1"
26	P05398126A	DIGITAL AMP METER
27	P05398128-1	START SWITCH
28	P05398128-2	START SWITCH
29	P05398129-1	STOP SWITCH
30	P05398129-2	STOP SWITCH
31	P05398131	EMERGENCY STOP SWITCH
32	P05398132	WIRE COLUMN
33	P05398133	COMPUTER
38	P05398130	POWER INDICATION LIGHT
39	P0571039	OL RELAY SCHN LT47 5-60A (G0571)

G0446 & G0539 440V CONVERSION PARTS

139V2	P0539139V2	440V CONVERSION KIT V2.09.10
12-1V2	P0539012-1V2	OL RELAY SCHN LR3D325 17-25A V2.09.10
14-1	P0539014-1	OL RELAY SCHN LR3D07 1.6-2.5A



COPYRIGHT © APRIL, 2010 BY GRIZZLY INDUSTRIAL, INC., REVISED DECEMBER, 2018 (BL)

WARNING: NO PORTION OF THIS MANUAL MAY BE REPRODUCED IN ANY SHAPE OR FORM WITHOUT THE WRITTEN APPROVAL OF GRIZZLY INDUSTRIAL, INC.

#TR12813 PRINTED IN TAIWAN

Replaces Page 46

Main Electrical Panel and Controls Diagram

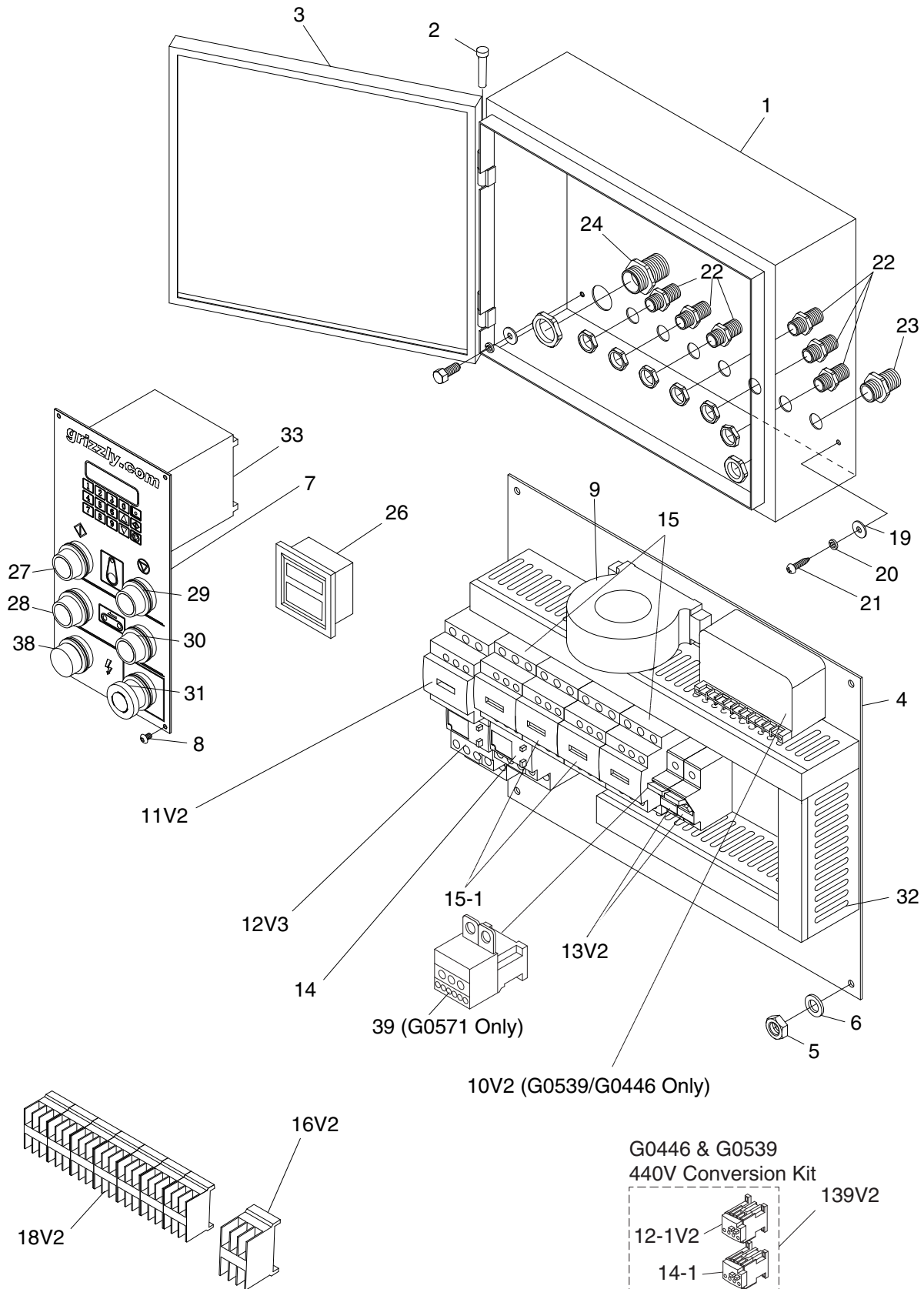

SECTION 3: SAFETY

For Your Own Safety, Read Instruction Manual Before Operating This Machine

The purpose of safety symbols is to attract your attention to possible hazardous conditions. This manual uses a series of symbols and signal words intended to convey the level of importance of the safety messages. The progression of symbols is described below. Remember that safety messages by themselves do not eliminate danger and are not a substitute for proper accident prevention measures. Always use common sense and good judgment.



Indicates an imminently hazardous situation which, if not avoided, **WILL** result in death or serious injury.



Indicates a potentially hazardous situation which, if not avoided, **COULD** result in death or serious injury.



Indicates a potentially hazardous situation which, if not avoided, **MAY** result in minor or moderate injury. It may also be used to alert against unsafe practices.

NOTICE

Alerts the user to useful information about proper operation of the machine to avoid machine damage.

Safety Instructions for Machinery

WARNING

OWNER'S MANUAL. Read and understand this owner's manual **BEFORE** using machine.

TRAINED OPERATORS ONLY. Untrained operators have a higher risk of being hurt or killed. Only allow trained/supervised people to use this machine. When machine is not being used, disconnect power, remove switch keys, or lock-out machine to prevent unauthorized use—especially around children. Make your workshop kid proof!

DANGEROUS ENVIRONMENTS. Do not use machinery in areas that are wet, cluttered, or have poor lighting. Operating machinery in these areas greatly increases the risk of accidents and injury.

MENTAL ALERTNESS REQUIRED. Full mental alertness is required for safe operation of machinery. Never operate under the influence of drugs or alcohol, when tired, or when distracted.

ELECTRICAL EQUIPMENT INJURY RISKS.

You can be shocked, burned, or killed by touching live electrical components or improperly grounded machinery. To reduce this risk, only allow qualified service personnel to do electrical installation or repair work, and always disconnect power before accessing or exposing electrical equipment.

DISCONNECT POWER FIRST.

Always disconnect machine from power supply **BEFORE** making adjustments, changing tooling, or servicing machine. This prevents an injury risk from unintended startup or contact with live electrical components.

EYE PROTECTION.

Always wear ANSI-approved safety glasses or a face shield when operating or observing machinery to reduce the risk of eye injury or blindness from flying particles. Everyday eyeglasses are **NOT** approved safety glasses.



WARNING

WEARING PROPER APPAREL. Do not wear clothing, apparel or jewelry that can become entangled in moving parts. Always tie back or cover long hair. Wear non-slip footwear to reduce risk of slipping and losing control or accidentally contacting cutting tool or moving parts.

HAZARDOUS DUST. Dust created by machinery operations may cause cancer, birth defects, or long-term respiratory damage. Be aware of dust hazards associated with each workpiece material. Always wear a NIOSH-approved respirator to reduce your risk.

HEARING PROTECTION. Always wear hearing protection when operating or observing loud machinery. Extended exposure to this noise without hearing protection can cause permanent hearing loss.

REMOVE ADJUSTING TOOLS. Tools left on machinery can become dangerous projectiles upon startup. Never leave chuck keys, wrenches, or any other tools on machine. Always verify removal before starting!

USE CORRECT TOOL FOR THE JOB. Only use this tool for its intended purpose—do not force it or an attachment to do a job for which it was not designed. Never make unapproved modifications—modifying tool or using it differently than intended may result in malfunction or mechanical failure that can lead to personal injury or death!

AWKWARD POSITIONS. Keep proper footing and balance at all times when operating machine. Do not overreach! Avoid awkward hand positions that make workpiece control difficult or increase the risk of accidental injury.

CHILDREN & BYSTANDERS. Keep children and bystanders at a safe distance from the work area. Stop using machine if they become a distraction.

GUARDS & COVERS. Guards and covers reduce accidental contact with moving parts or flying debris. Make sure they are properly installed, undamaged, and working correctly **BEFORE** operating machine.

FORCING MACHINERY. Do not force machine. It will do the job safer and better at the rate for which it was designed.

NEVER STAND ON MACHINE. Serious injury may occur if machine is tipped or if the cutting tool is unintentionally contacted.

STABLE MACHINE. Unexpected movement during operation greatly increases risk of injury or loss of control. Before starting, verify machine is stable and mobile base (if used) is locked.

USE RECOMMENDED ACCESSORIES. Consult this owner's manual or the manufacturer for recommended accessories. Using improper accessories will increase the risk of serious injury.

UNATTENDED OPERATION. To reduce the risk of accidental injury, turn machine **OFF** and ensure all moving parts completely stop before walking away. Never leave machine running while unattended.

MAINTAIN WITH CARE. Follow all maintenance instructions and lubrication schedules to keep machine in good working condition. A machine that is improperly maintained could malfunction, leading to serious personal injury or death.

DAMAGED PARTS. Regularly inspect machine for damaged, loose, or mis-adjusted parts—or any condition that could affect safe operation. Immediately repair/replace **BEFORE** operating machine. For your own safety, **DO NOT** operate machine with damaged parts!

MAINTAIN POWER CORDS. When disconnecting cord-connected machines from power, grab and pull the plug—**NOT** the cord. Pulling the cord may damage the wires inside. Do not handle cord/plug with wet hands. Avoid cord damage by keeping it away from heated surfaces, high traffic areas, harsh chemicals, and wet/damp locations.

EXPERIENCING DIFFICULTIES. If at any time you experience difficulties performing the intended operation, stop using the machine! Contact our Technical Support at (570) 546-9663.



Additional Safety for Wide Belt Sanders

WARNING

Serious injury or death can occur from hands getting trapped between workpiece and conveyor table, getting entangled in rotating parts inside machine, or lacerated by sanding drum. Workpieces thrown by sander can strike nearby operators. Long-term respiratory damage can occur from using sander without proper use of a respirator and an adequate dust collection system. To minimize risk of getting hurt or killed, anyone operating machine **MUST** completely heed hazards and warnings below.

FEEDING WORKPIECE. DO NOT place fingers under bottom of workpiece while feeding it into sander. Fingers can become pinched between workpiece and conveyor.

ENTANGLEMENT HAZARDS. DO NOT wear loose clothing, gloves, or jewelry, and tie back long hair. Never reach inside operating machine or try clearing jammed workpiece. Keep all guards in place and secure, and all doors closed.

SANDING DRUM CONTACT. Rotating sandpaper can remove a large amount of flesh in a few seconds. Keep hands away from rotating sanding drum(s) during operation. Never touch moving sandpaper on purpose.

WORKPIECE KICKBACK. A workpiece can be ejected out the front of sander at high rate of speed, and hit operator or bystanders. Never stand in-line with workpiece, never feed more than one workpiece at a time, and always adjust pressure rollers below sanding roller.

MINIMUM STOCK DIMENSION. To avoid kick-back, never sand workpieces below minimum specifications listed in **Data Sheet**.

ADJUSTMENTS/MAINTENANCE. Make sure machine is turned **OFF**, disconnected from power and air, and all moving parts are completely stopped before doing adjustments or maintenance.

SANDING DUST. Sanding creates large amounts of dust and flying chips that can lead to eye injury or respiratory illness. Reduce risk of these hazards by wearing approved eye and respiratory protection when using sander.

DUST COLLECTION. Never operate without adequate dust collection system in place and running. Proper dust collection reduces dust in work area, which decreases risk of long-term respiratory damage, but it is not a substitute for using a respirator.

WARNING

Like all machinery there is potential danger when operating this machine. Accidents are frequently caused by lack of familiarity or failure to pay attention. Use this machine with respect and caution to decrease the risk of operator injury. If normal safety precautions are overlooked or ignored, serious personal injury may occur.

CAUTION

No list of safety guidelines can be complete. Every shop environment is different. Always consider safety first, as it applies to your individual working conditions. Use this and other machinery with caution and respect. Failure to do so could result in serious personal injury, damage to equipment, or poor work results.



SECTION 4: POWER SUPPLY

Availability

Before installing the machine, consider the availability and proximity of the required power supply circuit. If an existing circuit does not meet the requirements for this machine, a new circuit must be installed. To minimize the risk of electrocution, fire, or equipment damage, installation work and electrical wiring must be done by an electrician or qualified service personnel in accordance with all applicable codes and standards.

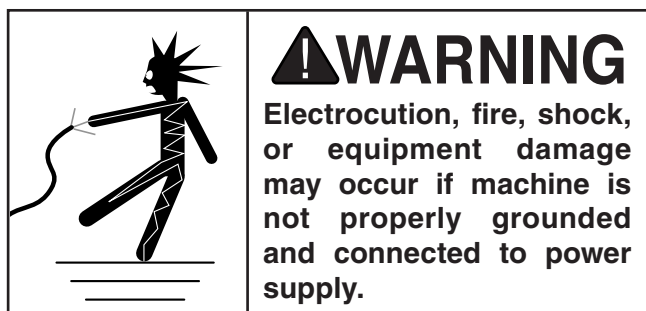

Full-Load Current Rating

The full-load current rating is the amperage a machine draws at 100% of the rated output power. On machines with multiple motors, this is the amperage drawn by the largest motor or sum of all motors and electrical devices that might operate at one time during normal operations.

G0446

Full-Load Current Rating at 220V .. 40.6 Amps
Full-Load Current Rating at 440V .. 20.3 Amps

G0539

Full-Load Current Rating at 220V .. 40.6 Amps
Full-Load Current Rating at 440V .. 20.3 Amps

G0571

Full-Load Current Rating at 220V .. 60.6 Amps

The full-load current is not the maximum amount of amps that the machine will draw. If the machine is overloaded, it will draw additional amps beyond the full-load rating.

If the machine is overloaded for a sufficient length of time, damage, overheating, or fire may result—especially if connected to an undersized circuit. To reduce the risk of these hazards, avoid overloading the machine during operation and make sure it is connected to a power supply circuit that meets the specified circuit requirements.



In Addition to Page 12

Circuit Information

A power supply circuit includes all electrical equipment between the breaker box or fuse panel in the building and the machine. The power supply circuit used for this machine must be sized to safely handle the full-load current drawn from the machine for an extended period of time. (If this machine is connected to a circuit protected by fuses, use a time delay fuse marked D.)

CAUTION

For your own safety and protection of property, consult an electrician if you are unsure about wiring practices or electrical codes in your area.

Note: *Circuit requirements in this manual apply to a dedicated circuit—where only one machine will be running on the circuit at a time. If machine will be connected to a shared circuit where multiple machines may be running at the same time, consult an electrician or qualified service personnel to ensure circuit is properly sized for safe operation.*

G0446 Circuit Requirements

For 220V

This machine is prewired to operate on a power supply circuit that has a verified ground and meets the following requirements:

**Nominal Voltage 220V, 230V, 240V
Cycle60 Hz
Phase 3-Phase
Power Supply Circuit 50 Amps**

For 440V

This machine can be converted to operate on a power supply circuit that has a verified ground and meets the requirements listed below. (Refer to **Voltage Conversion** instructions for details.)

**Nominal Voltage 440V, 480V
Cycle60 Hz
Phase 3-Phase
Power Supply Circuit 30 Amps**

G0539 Circuit Requirements

For 220V

This machine is prewired to operate on a power supply circuit that has a verified ground and meets the following requirements:

**Nominal Voltage 220V, 230V, 240V
Cycle60 Hz
Phase 3-Phase
Power Supply Circuit 50 Amps**

For 440V

This machine can be converted to operate on a power supply circuit that has a verified ground and meets the requirements listed below. (Refer to **Voltage Conversion** instructions for details.)

**Nominal Voltage 440V, 480V
Cycle60 Hz
Phase 3-Phase
Power Supply Circuit 30 Amps**

G0571 Circuit Requirements

For 220V

This machine is prewired to operate on a power supply circuit that has a verified ground and meets the following requirements:

**Nominal Voltage 220V, 230V, 240V
Cycle60 Hz
Phase Single-Phase
Power Supply Circuit 70 Amps**



In Addition to Page 12

Connection Type

A permanently connected (hardwired) power supply is typically installed with wires running through mounted and secured conduit. A disconnecting means, such as a locking switch (see following figure), must be provided to allow the machine to be disconnected (isolated) from the power supply when required. This installation must be performed by an electrician in accordance with all applicable electrical codes and ordinances.

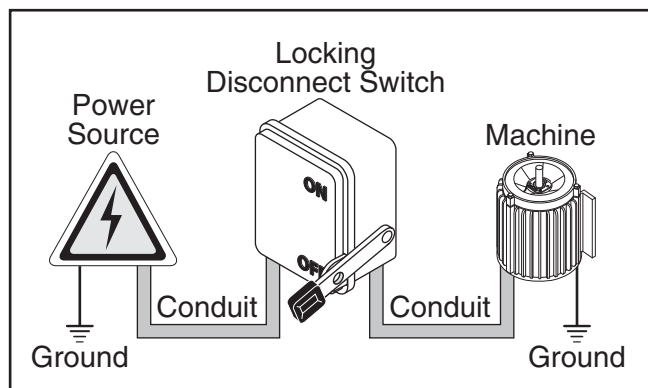

Figure 3. Typical setup of a permanently connected machine.

Grounding Instructions

In the event of a malfunction or breakdown, grounding provides a path of least resistance for electrical current to reduce the risk of electric shock. A permanently connected machine must be connected to a grounded metal permanent wiring system; or to a system having an equipment-grounding conductor. All grounds must be verified and rated for the electrical requirements of the machine. Improper grounding can increase the risk of electric shock!

⚠️ WARNING

Serious injury could occur if you connect machine to power before completing setup process. DO NOT connect to power until instructed later in this manual.

Extension Cords

Since this machine must be permanently connected to the power supply, an extension cord cannot be used.



Replaces Page 13

440V Connection (G0446/G0539)

This machine is prewired for 220V 3-phase power but has the capability of operating on 440V power with a minor conversion. The conversion consists of replacing two overload relays and rewiring each of the three motors.

All wiring changes must be inspected by a qualified electrician or service personnel before the machine is connected to the power source. If, at any time during this procedure you need help, call Grizzly Tech Support at (570) 546-9663.

Contact the Grizzly Order Desk at (800) 523-4777 to purchase the following 440V conversion kit that includes the necessary two overload relays:

Description	Part Number
440V Conversion Kit.....	P0539139

To wire the Model G0446/G0539 to 440V:

1. DISCONNECT SANDER FROM POWER!
2. Open the electrical box located on the back of the machine.
3. Remove the wire labeled "1" at the 220V terminal of the control power transformer (see **Figure 7**) and connect it to the 440V terminal.

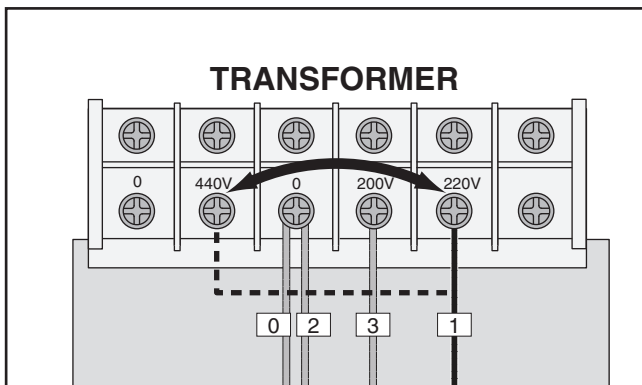

Figure 7. The "1" wire should be connected to the 440V terminal.

4. Remove the LRD340 overload relay, and replace it with an LR3D325 (17-25A) type (see **Figure 8**), with the dial set to 18A.

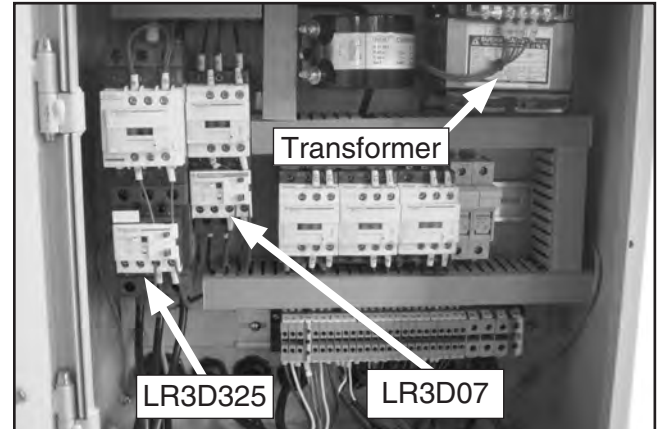

Figure 8. Overload relay.

5. Remove the LR3D08 overload relay, and replace it with an LR3D07 (1.6-2.5A) type (see **Figure 8**), with the dial set to 1.7A.
6. Wire the sanding belt, conveyor belt, and table elevation motors as shown in the diagrams on **Page 40** of the owner's manual.



Replaces Page 38

Control Panel Electrical Diagram (G0446/G0539)

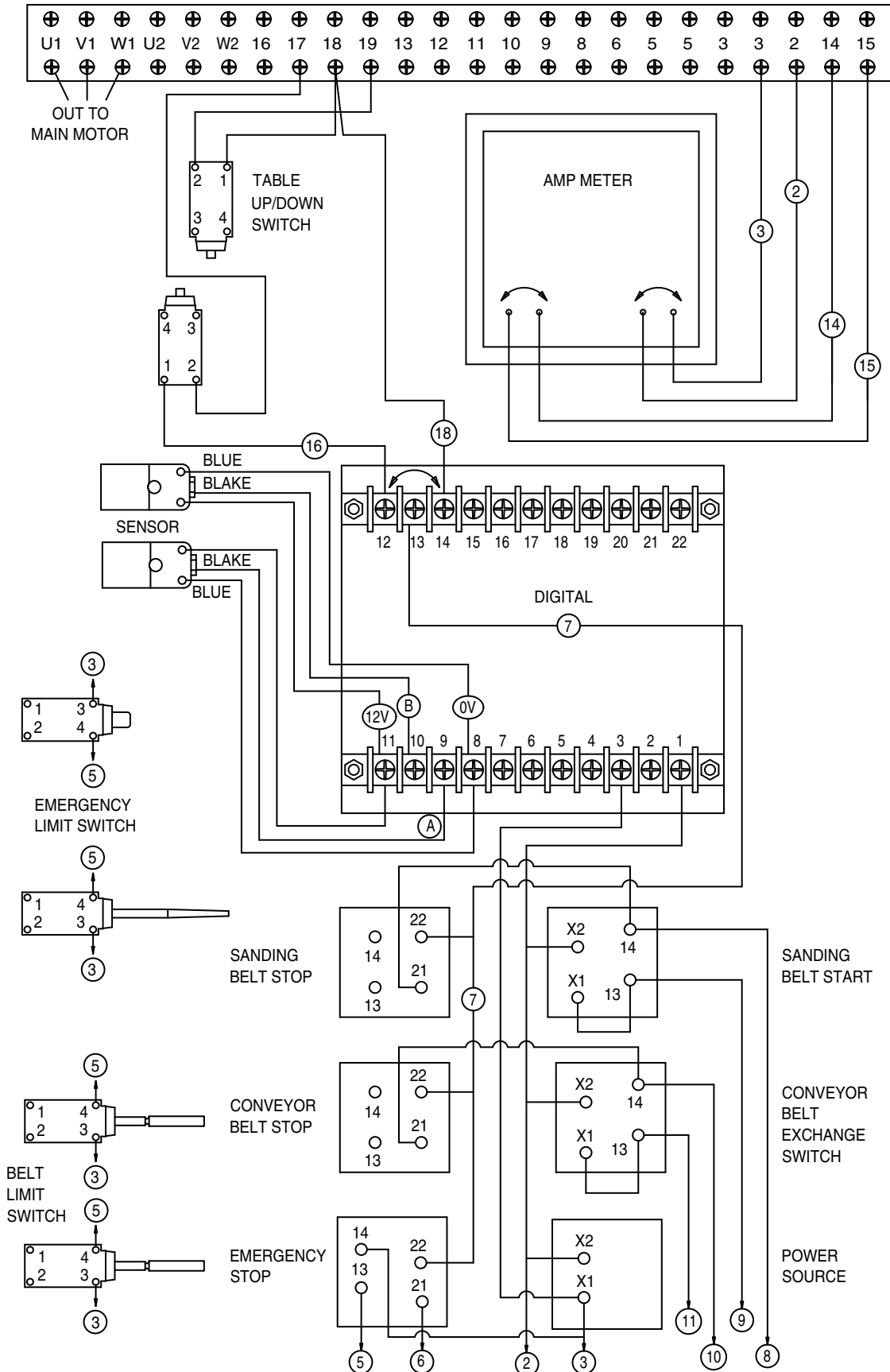

Replaces Page 38

Control Panel Electrical Diagram (G0571)

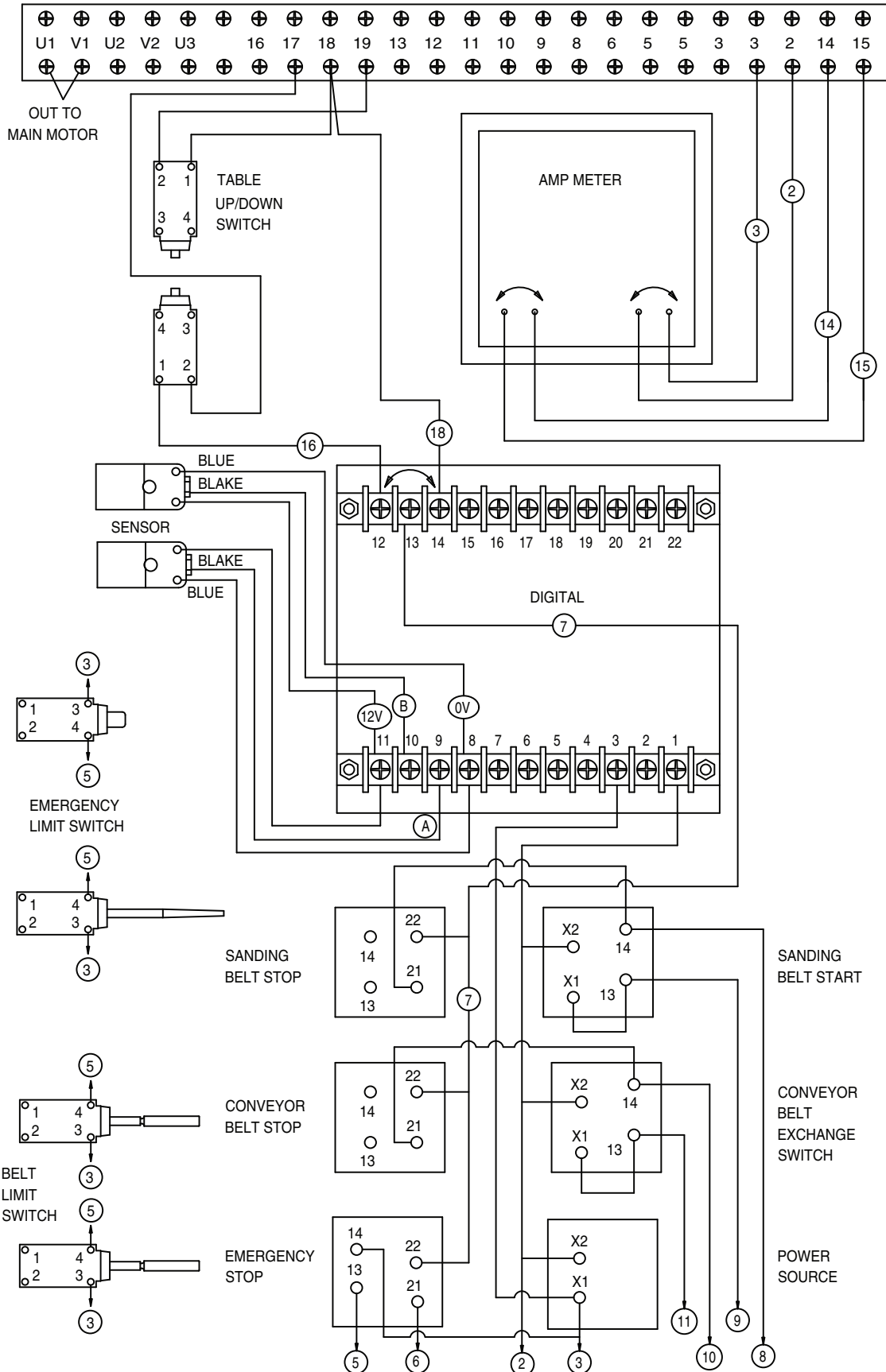

Replaces Page 40, Except for Motor Wiring Diagrams

Wiring Box Electrical Diagram (G0446/G0539)

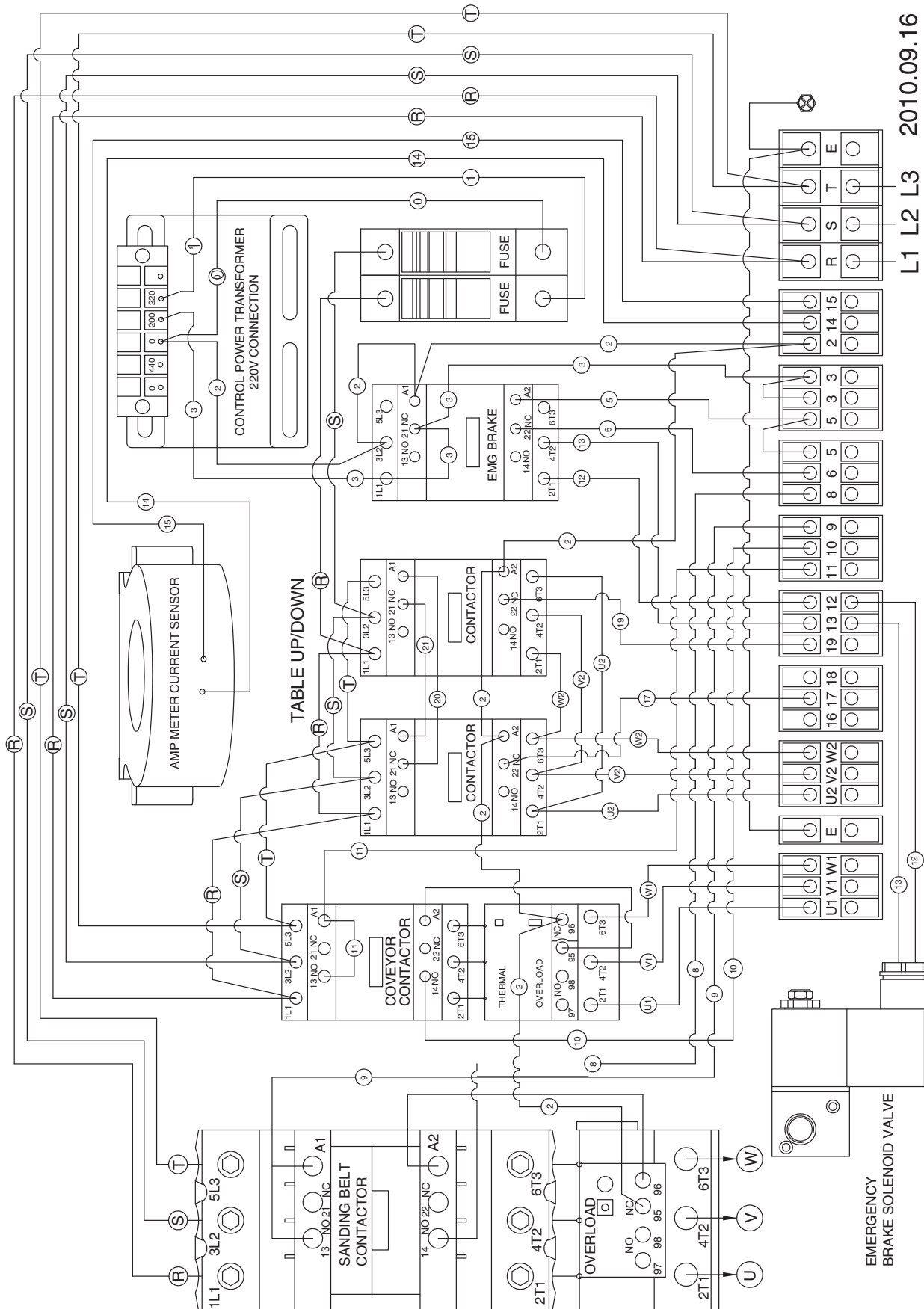

Replaces Page 42, Except for Motor Wiring Diagrams
Wiring Box Electrical Diagram (G0571)

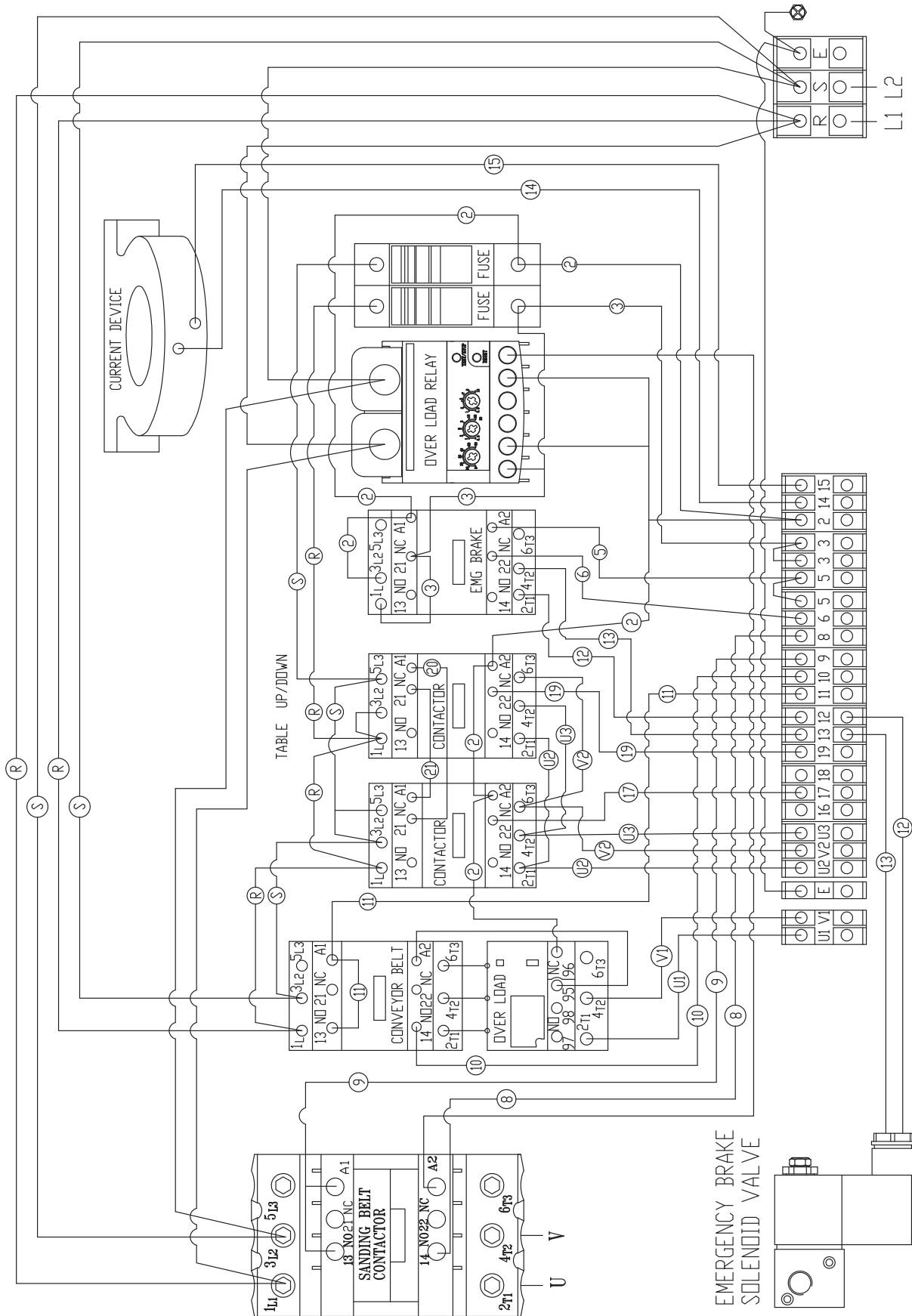

Replaces Page 41

Wiring Box Components (G0446/G0539)

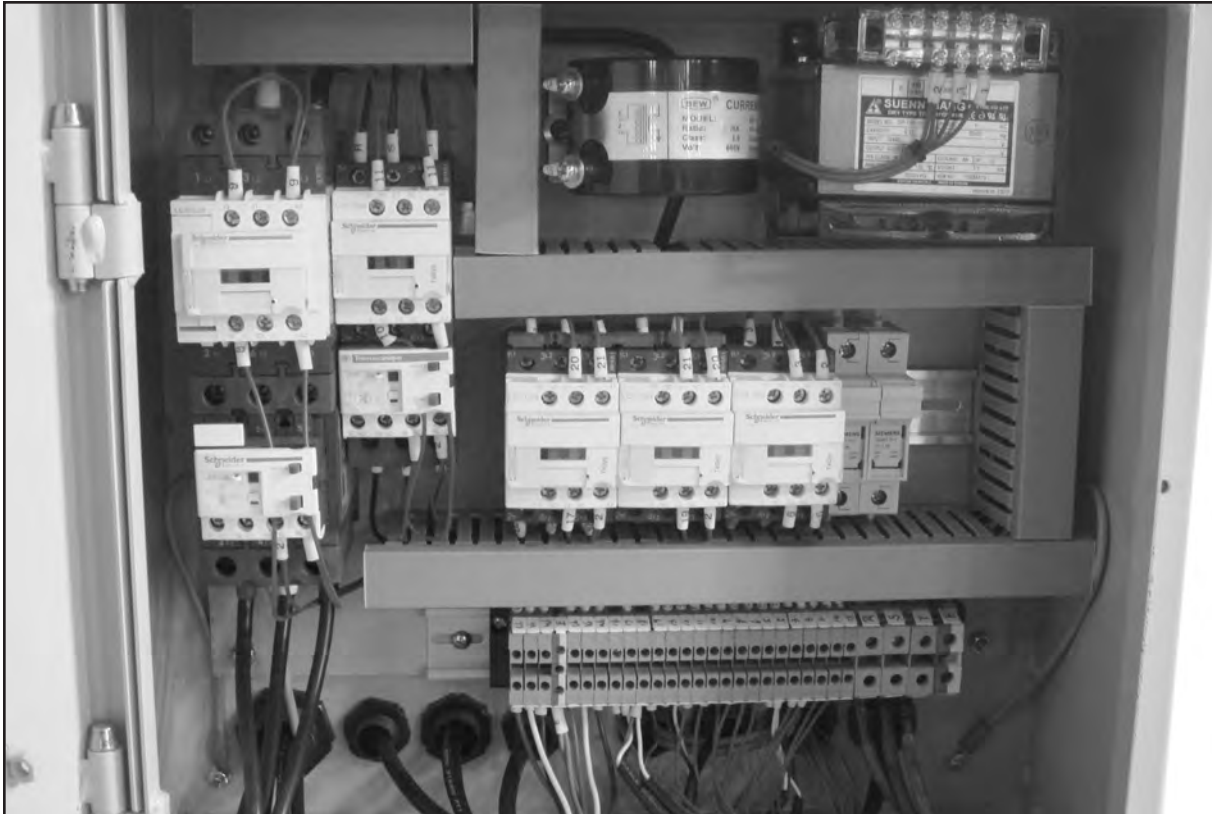

Replaces Page 43

Wiring Box Components (G0571)

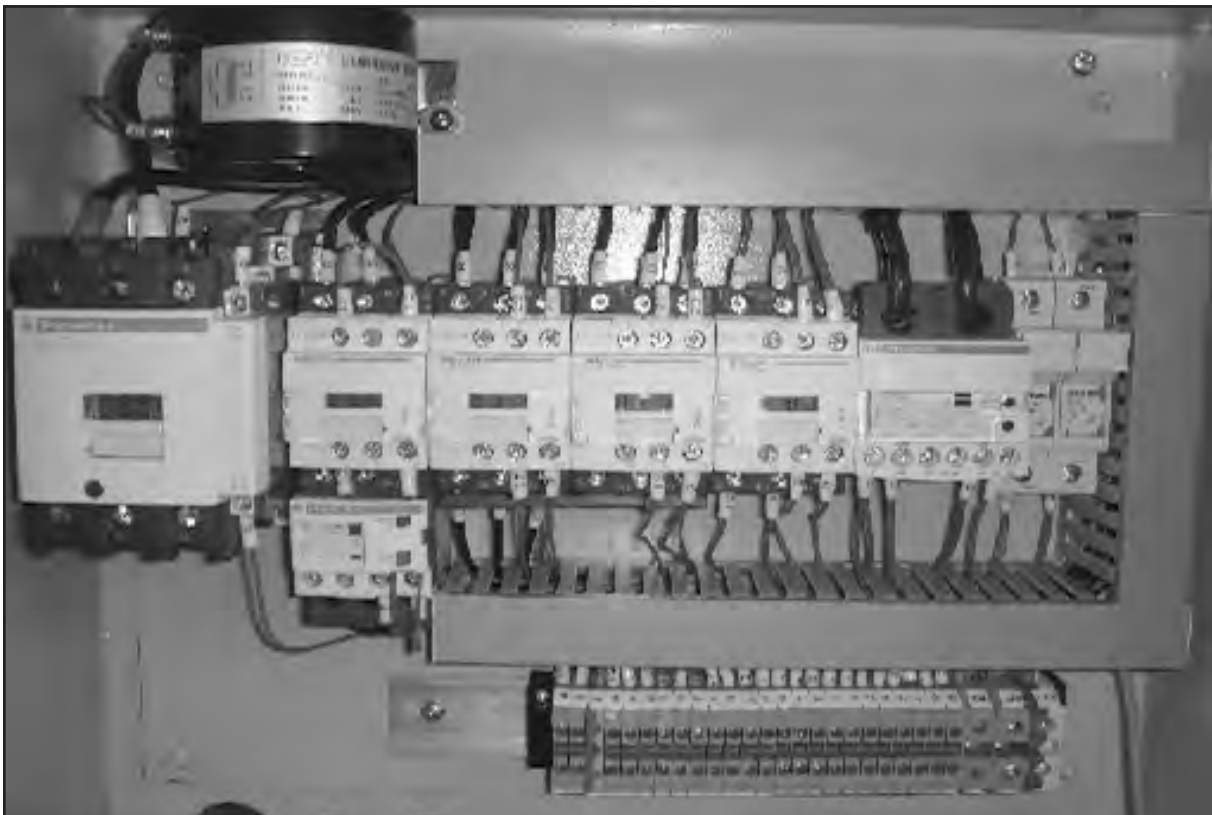

Replaces Page 44

General Electrical Diagram (G0446/G0539)

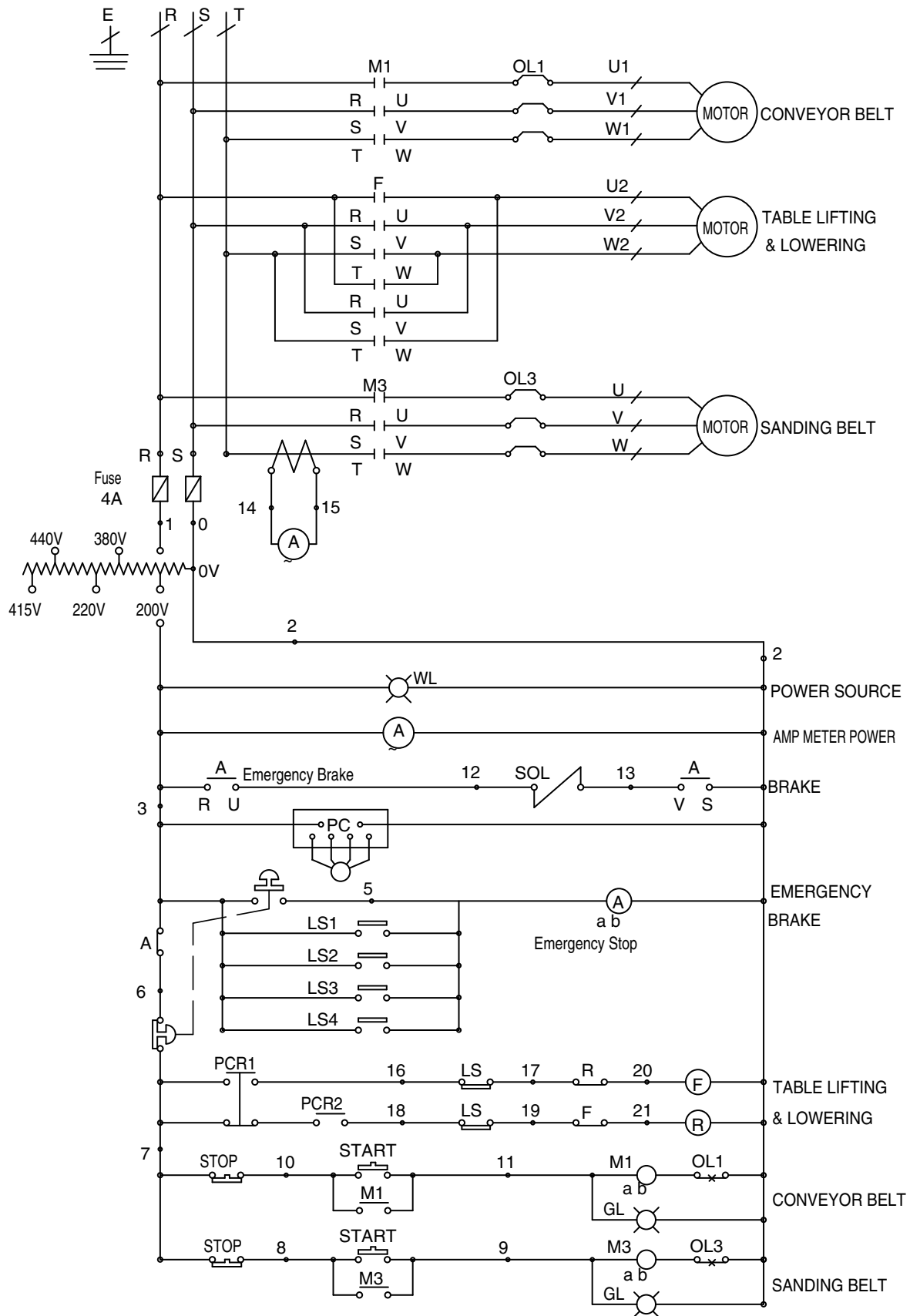

Replaces Page 45

General Electrical Diagram (G0571)

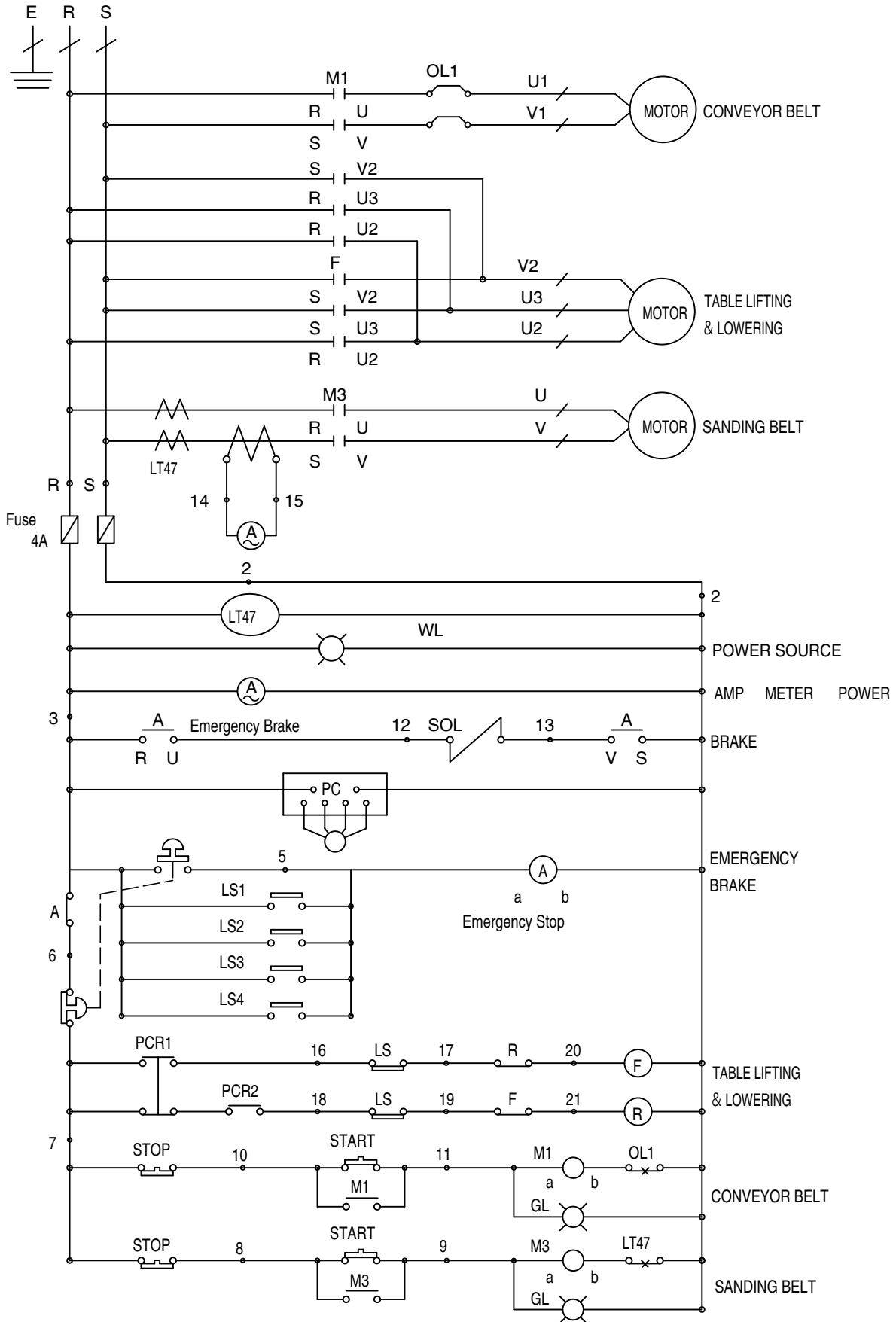

Replaces Page 54

Upper Roller System Diagram

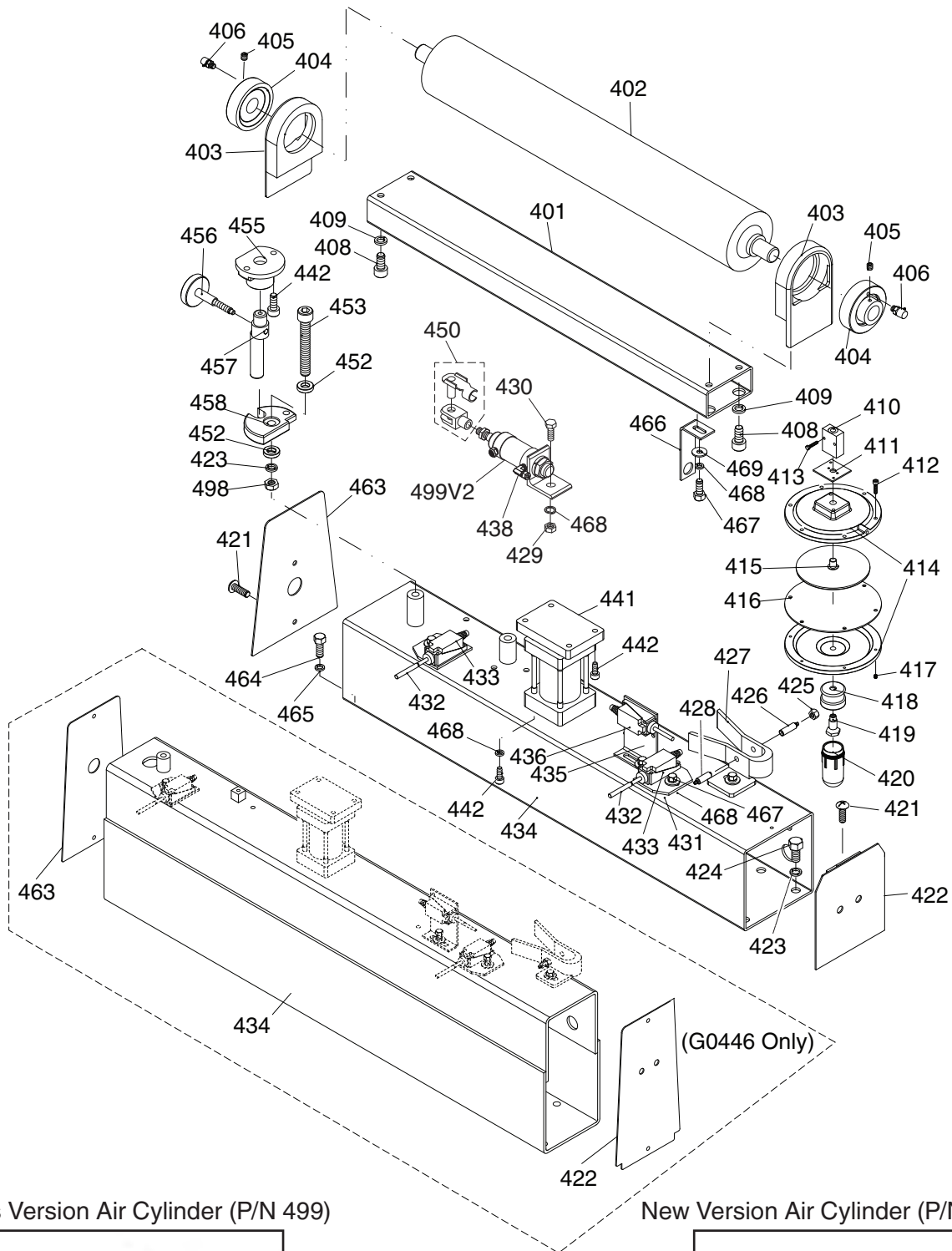

Previous Version Air Cylinder (P/N 499)

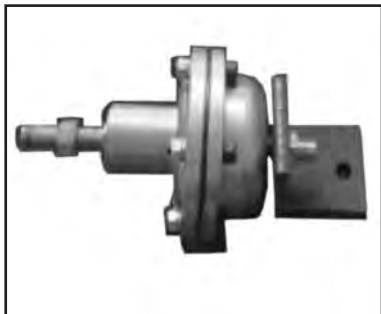

New Version Air Cylinder (P/N 499V2)



Replaces Page 55

Upper Roller System Parts List

REF	PART #	DESCRIPTION
401	P0539401	ROLLER BRACKET (UPPER)
402	P0539402	ROLLER (UPPER)
403	P0539403	ROLLER END BRACKET (UPPER)
404	P0539404	BEARING UCC205
405	P0539405	SET SCREW M6-1 X 6
406	P0539406	GREASE FITTING W/ DUST CAP
408	P0539408	CAP SCREW 3/8-16 X 3/4
409	P0539409	LOCK WASHER 3/8
410	P0539410	THROTTLE VALVE
411	P0539411	THROTTLE VALVE BASE
412	P0539412	CAP SCREW 10-24 x 3/4
413	P0539413	PHLP HD SCR M4-.7 X 20
414	P0539414	ALUMINUM DISC
415	P0539415	ALUMINUM PLATE
416	P0539416	PLATE
417	P0539417	HEX NUT 10-24
418	P0539418	OIL CAP CONNECTOR
419	P0539419	SHAFT OF OIL CAP
420	P0539420	OIL CAP
421	P0539421	PHLP HD SCR 1/4-20 X 1/2
422	P0539422	FRAME SEAL (RH) (G0539/G0446)
422	P0446422	FRAME SEAL (RH) (G0446)
423	P0539423	LOCK WASHER 1/2
424	P0539424	HEX BOLT 1/2-12 X 1
425	P0539425	HEX NUT 3/8-24
426	P0539426	AIR NOZZLE (FEMALE)
427	P0539427	AIR CYLINDER BRACKET
428	P0539428	AIR RECEIVER (MALE)
429	P0539429	HEX NUT 5/16-18

REF	PART #	DESCRIPTION
430	P0539430	HEX BOLT 5/16-18 X 1-1/2
431	P0539431	LIMIT SWITCH HOLDER
432	P0539432	LIMIT SWITCH TUBE
433	P0539433	LIMIT SWITCH W/CERAMIC TIP
434	P0446434	SQUARE FRAME (G0446)
434	P0539434	SQUARE FRAME (G0539/G0446)
435	P0539435	HOLDER (L-TYPE)
436	P0539436	LIMIT SWITCH W/PLASTIC ROD
438	P0539524	CONNECTOR 1/4N X 1/8T X 90 DEG
441	P0539441	AIR CYLINDER
442	P0539442	CAP SCREW 5/16-18 X 3/4
450	P0539450	UNIVERSAL JOINT FORK ASSY
452	P0539452	FLAT WASHER 1/2
453	P0539453	CAP SCREW 1/2-12 X 3-1/2
455	P0539455	FRAME
456	P0539456	TRIMMING SCREW
457	P0539457	ECCENTRIC ROD
458	P0539458	ECCENTRIC PIECE
463	P0446463	FRAME SEAL (LH) (G0446)
463	P0539463	FRAME SEAL (LH) (G0539 & G0571)
464	P0539464	HEX BOLT 3/8-16 X 1
465	P0539465	LOCK WASHER 3/8
466	P05396128	POWER OFF PLATE
467	P0539467	HEX BOLT 5/16-18 X 3/4
468	P0539468	LOCK WASHER 5/16
469	P0539469	FLAT WASHER 5/16
498	P0539498	HEX NUT 1/2-12
499V2	P0539499V2	OSCILLATION AIR CYLINDER V2.01.14



Replaces Page 56 & 57
Belt Oscillation System

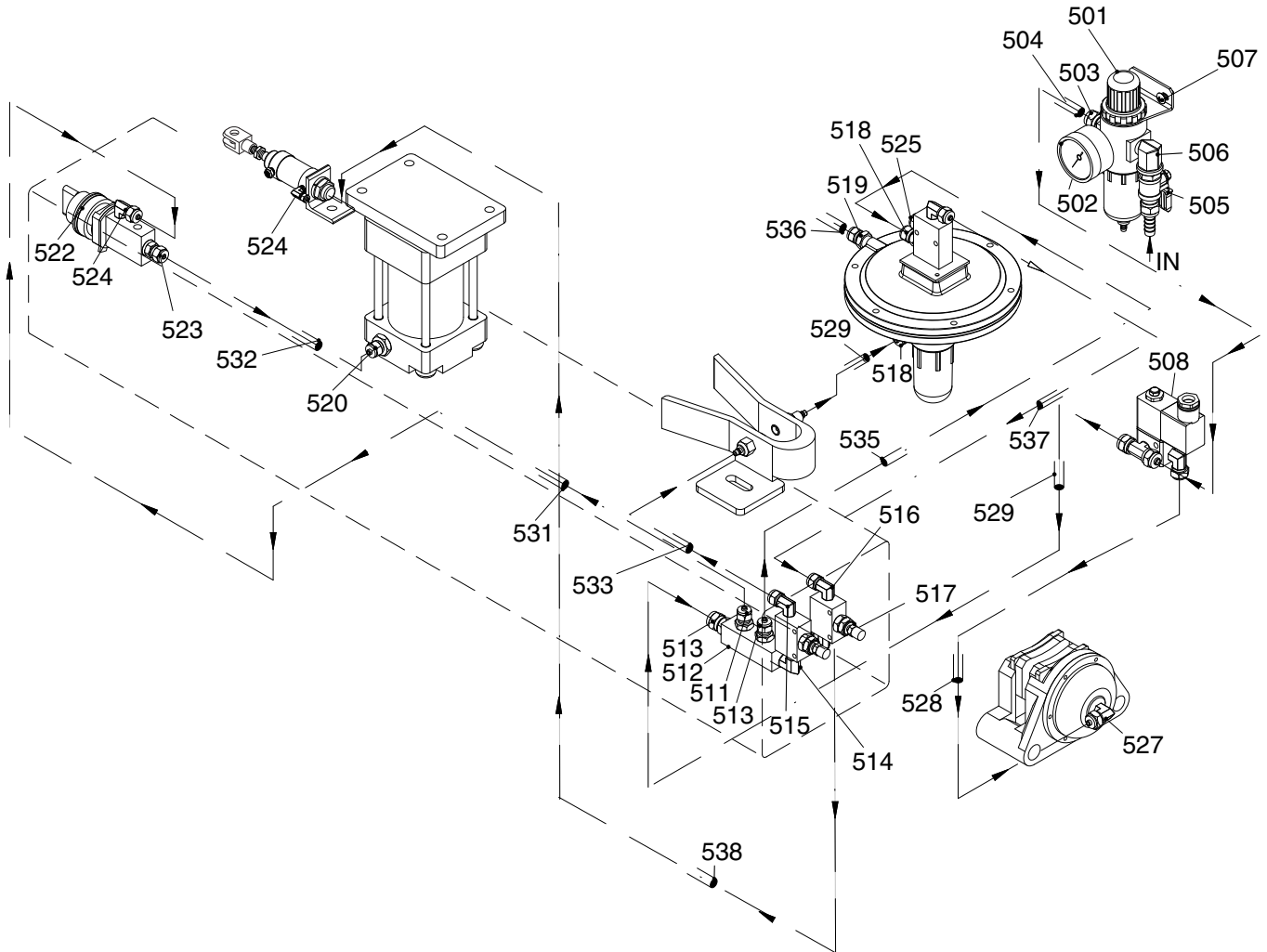

REF	PART #	DESCRIPTION
501	P0539501	PRESSURE REGULATOR
502	P0539502	PSI GAUGE
503	P0539503	CONNECTOR, BRONZE
504	P0539504	FLEXIBLE HOSE 8MM
505	P0539505	AIR SWITCH
506	P0539506	ELBOW
507	PS22	PHLP HD SCR 10-24 x 5/8
508	P9962Z9109	SOLENOID VALVE
511	P0539511	CONNECTOR, BRONZE
512	P0539512	AIR MANIFOLD
513	P0539513	CONNECTOR, BRONZE
514	P0539514	ELBOW 1/4T X 1/8T X 90°, BRONZE
515	P0539515	CONNECTOR 1/4N X 1/8T X 90°
516	P0539516	CONNECTOR 1/4N X 1/8T X 90°
517	P0539517	NEEDLE VALVE
518	P0539518	CONNECTOR, BRONZE

REF	PART #	DESCRIPTION
519	P0539519	ELBOW, BRONZE
520	P0539520	CONNECTOR 1/4N X 3/8T
522	P0539522	AIR SWITCH 1/8
523	P0539523	CONNECTOR 1/4N X 1/8T
524	P0539524	CONNECTOR 1/4N X 1/8T X 90°
525	P0539525	BUFFER, BRONZE
527	P0539527	CONNECTOR 5/16N X 1/8T X 90°
528	P0539528	FLEXIBLE HOSE 8MM
529	P0539529	FLEXIBLE HOSE 8MM
531	P0539531	FLEXIBLE HOSE 6MM
532	P0539532	FLEXIBLE HOSE 6MM
533	P0539533	FLEXIBLE HOSE 6MM
535	P0539535	FLEXIBLE HOSE 6MM
536	P0539536	FLEXIBLE HOSE 6MM
537	P0539537	FLEXIBLE HOSE 6MM
538	P0539538	FLEXIBLE HOSE 6MM



grizzly.com[®]

TOOL WEBSITE

Buy Direct and Save with Grizzly[®] – Trusted, Proven and a Great Value!
~Since 1983~

*Visit Our Website Today For
Current Specials!*

**ORDER
24 HOURS A DAY!
1-800-523-4777**



Grizzly **Industrial, Inc.**®

37" WIDE BELT SANDERS

MODELS G0446, G0539, G0571 INSTRUCTION MANUAL



COPYRIGHT © MAY 2005 BY GRIZZLY INDUSTRIAL, INC.
**WARNING: NO PORTION OF THIS MANUAL MAY BE REPRODUCED IN ANY SHAPE
OR FORM WITHOUT THE WRITTEN APPROVAL OF GRIZZLY INDUSTRIAL, INC.**
#CR6971 PRINTED IN TAIWAN

WARNING

Some dust created by power sanding, sawing, grinding, drilling, and other construction activities contains chemicals known to the State of California to cause cancer, birth defects or other reproductive harm. Some examples of these chemicals are:

- Lead from lead-based paints.
- Crystalline silica from bricks, cement, and other masonry products.
- Arsenic and chromium from chemically treated lumber.

Your risk from these exposures varies, depending on how often you do this type of work. To reduce your exposure to these chemicals: work in a well ventilated area, and work with approved safety equipment, such as those dust masks that are specially designed to filter out microscopic particles.

Table of Contents

- SECTION 1: INTRODUCTION 3**
 - Foreword 3
 - Contact Info 3
- SECTION 2: MACHINE FEATURES 4**
 - External Features 4
 - Control Panel 4
 - Access Doors 5
 - Machine Data Sheet (G0446/G0539) 6
 - Machine Data Sheet (G0571) 7
- SECTION 3: SAFETY 8**
 - Safety Instructions for Machinery 8
 - Additional Safety for Wide Belt Sanders 10
- SECTION 4: CIRCUIT REQUIREMENTS 11**
 - 220V & 440V Operation 11
 - Connection Type 11
 - Grounding 12
 - Extension Cords 12
 - 440V Connection (G0446/G0539) 13
- SECTION 5: SET UP 14**
 - Unpacking 14
 - Inventory 14
 - Hardware Chart 15
 - Clean Up 16
 - Site Considerations 16
 - Beginning Assembly 17
 - Floor Mounting 17
 - Air Line Installation 18
 - Dust Collection 18
 - Sanding Belt 19
 - Pressure Rollers 20
 - Start Up 20
 - Recommended Adjustments 21
- SECTION 6: OPERATIONS 22**
 - Operation Safety 22
 - Choosing Sandpaper 22
 - Table Movement 23
 - Adjusting Feed Rate 23
 - Amp Draw Meter 24
 - Sanding Workpiece 25
 - Platen Adjustment 25
- SECTION 7: ACCESSORIES 26**
- SECTION 8: MAINTENANCE 27**
 - General 27
 - Schedule 27
 - Sanding Belts 28
 - Air System 28
 - Dust and Water Traps 28

SECTION 9: SERVICE	29
Table Calibration	29
Brake Service	30
Feed Belt Tension	31
Feed Belt Tracking	31
Oscillation Timing	32
Oscillation Speed	34
Table Parallelism.....	34
Pressure Rollers.....	35
V-Belt Adjustment	36
Air System Diagram (G0446/G0539/G0571)	37
Main Electrical Panel and Controls Diagram	46
Parts List	47
Sanding Motor Diagram	48
Parts List	49
Table Lift System Diagram.....	50
Parts List	51
Conveyor System Diagram	52
Parts List	53
Upper Roller System Diagram	54
Parts List	55
Belt Oscillation System Diagram.....	56
Parts List	57
Feed, Drum, and Pressure Roller Diagram.....	58
Parts List	59
Cabinet Assembly Diagram.....	60
Parts List	61
Tool Box and Accessories Diagram.....	62
Parts List	63
Troubleshooting.....	64
Warranty & Returns.....	66
Warranty Card.....	67

SECTION 1: INTRODUCTION

Foreword

We are proud to offer the Models G0539, G0571, G0446 37" Wide Belt Sanders. This machine is part of a growing Grizzly family of fine wood-working machinery. When used according to the guidelines set forth in this manual, you can expect years of trouble-free, enjoyable operation and proof of Grizzly's commitment to customer satisfaction.

We are pleased to provide this manual with the Models G0539, G0571, G0446 37" Wide Belt Sanders. It was written to guide you through assembly, review safety considerations, and cover general operating procedures.

The specifications, drawings, and photographs illustrated in this manual represent the Models G0539, G0571, G0446 37" Wide Belt Sanders as supplied when the manual was prepared. For your convenience, we always keep current Grizzly manuals available on our website at **www.grizzly.com**. Any updates to your machine will be reflected in these manuals as soon as they are complete.



Contact Info

If you have any comments regarding this manual, please write to us at the address below:

Grizzly Industrial, Inc.
c/o Technical Documentation Manager
P.O. Box 2069
Bellingham, WA 98227-2069

We stand behind our machines. If you have any service questions or parts requests, please call or write us at the location listed below.

Grizzly Industrial, Inc.
1203 Lycoming Mall Circle
Muncy, PA 17756
Phone: (570) 546-9663
Fax: (800) 438-5901
E-Mail: techsupport@grizzly.com
Web Site: <http://www.grizzly.com>



SECTION 2: MACHINE FEATURES

External Features

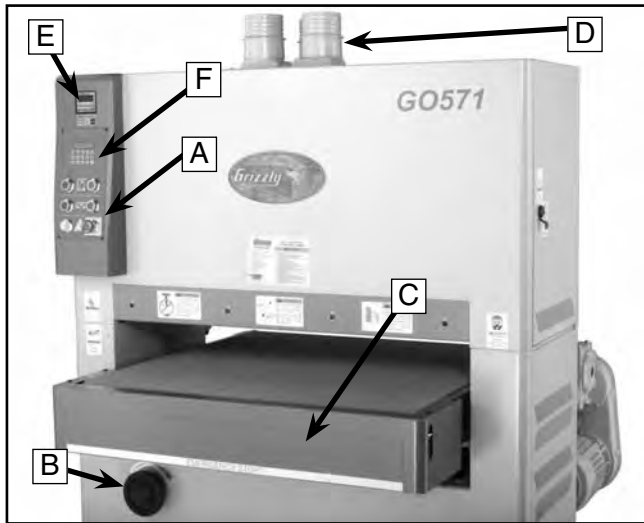

Figure 1. Front View.

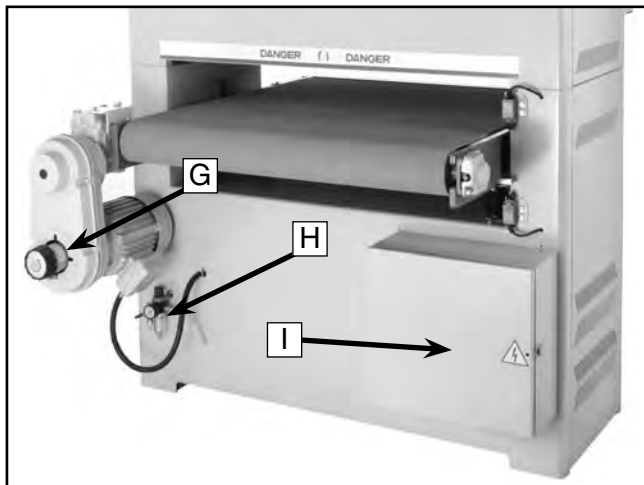

Figure 2. Rear View.

- A. Control Panel
- B. Table Height Handwheel
- C. Emergency Stop Bar
- D. 4" Dust Port (3)
- E. Amp (Load) Meter
- F. Digital Table Height Key Pad
- G. Conveyor Speed Control
- H. Air Pressure Regulator
- I. Main Wiring Box

Control Panel

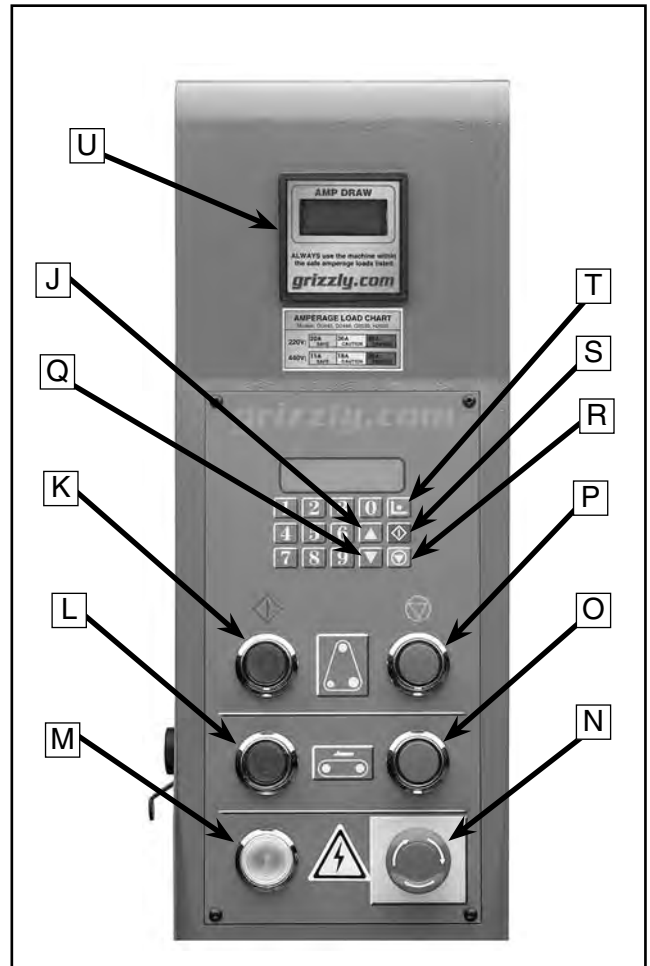

Figure 3. Control Panel.

- J. Table Up Key
- K. Sanding Belt Start Button
- L. Conveyor Belt Start Button
- M. Power Light
- N. Emergency Stop Button
- O. Feed Belt Stop Button
- P. Sanding Belt Stop Button
- Q. Table Down Key
- R. Table Stop Key
- S. Table Start Key
- T. Table Set (Enter) Key
- U. Table-Height Digital Readout



Access Doors

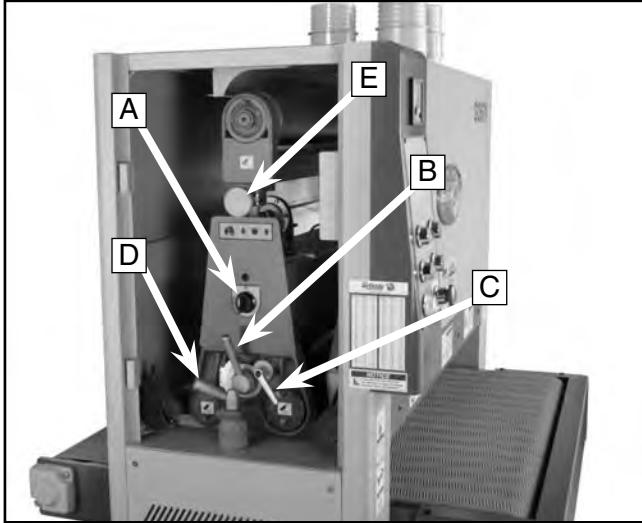

Figure 4. Inside the left access door.

- A. Belt Tension Knob
- B. Platen Adjustment Lever
- C. Platen Adjustment Lock Lever
- D. Lock Post Release Lever
- E. Tracking Adjustment Knob

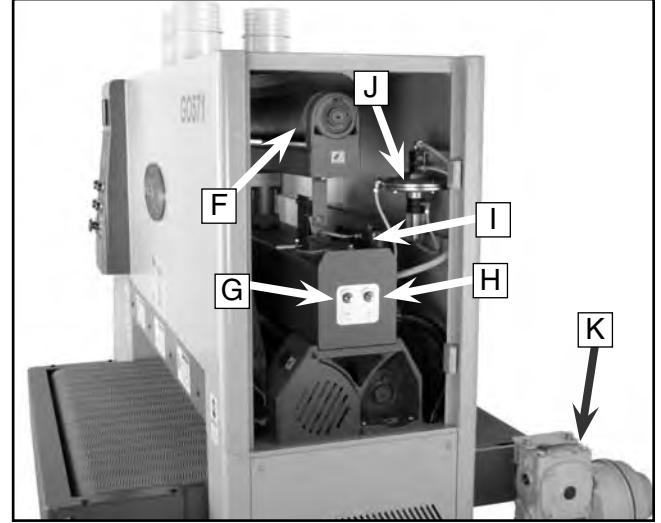

Figure 5. Inside the right access door.

- F. Upper Roller
- G. Airflow Adjustment Knob
- H. Speed Control Adjustment Knob
- I. Air Fork and Air Jet
- J. Diaphragm Valve Assembly
- K. Conveyor Gearbox and Control





MACHINE DATA SHEET

Customer Service #: (570) 546-9663 • To Order Call: (800) 523-4777 • Fax #: (800) 438-5901

MODEL G0446 & G0539 37" WIDE-BELT SANDERS

Design Type Floor Model

Overall Dimensions:

Width (G0539: 53"), (G0446: 56½")
 Height W/Dust Ports..... (G0539: 69½"), (G0446: 77½")
 Height W/O Dust Ports..... (G0539: 64"), (G0446: 71½")
 Depth..... (G0539: 49½"), (G0446: 52")
 Conveyor Height at Lowest Setting..... 32"
 Net Weight (G0539: 2300 lbs.), (G0446: 2094 lbs.)
 Footprint..... 19" x 51½"

Capacities:

Maximum Board Width..... (G0539: 36"), (G0446: 36½")
 Maximum Board Thickness..... 6"
 Minimum Board Length..... (G0539: 14"), (G0446: 9")
 Minimum Board Thickness..... ⅛"
 Belt Speed..... 2600 FPM
 Conveyor Speed 15-49 FPM
 Dust Ports (3)..... 4"

Sanding Drum Motor:

Type TEFC Induction
 Horsepower..... 15 HP
 Voltage / Phase / Cycle..... 220V / 440V Three-Phase / 60 HZ
 Amps 36 / 18 A
 RPM 1725 RPM
 Power Transfer to Drums Triple V-Belt

Conveyor Feed Motor:

Type TEFC Induction
 Horsepower..... 1 HP
 Voltage / Phase / Cycle..... 220V / 440V Three-Phase / 60 HZ
 Amps 3.4 / 1.7 A
 RPM 1725
 Power Transfer..... V-Belt

Table Lift Motor:

Type TEFC Induction
 Horsepower..... ¼ HP
 Voltage / Phase / Cycle..... 220V / 440V Three-Phase / 60 HZ
 Amps 1.2 / 0.6 A
 RPM 1725
 Power Transfer..... V-Belt

General Construction:

Cabinet..... Steel
 Operating Air Pressure..... 75 PSI
 Sanding Belt Oscillation Adjustable
 Sanding Belt Brake Air Disc Brake
 Control Panel Push Button for each motor, plus load sensor
 Sanding Belt..... (G0539: 36" x 60"), (G0446: 37" x 75")

Specifications, while deemed accurate, are not guaranteed.



MACHINE DATA SHEET

Customer Service #: (570) 546-9663 • To Order Call: (800) 523-4777 • Fax #: (800) 438-5901

MODEL G0571 37" WIDE-BELT SANDER

Design Type Floor Model

Overall Dimensions:

Width 53"
 Height W/Dust Ports..... 69½"
 Height W/O Dust Ports..... 64"
 Depth..... 49½"
 Conveyor Height at Lowest Setting..... 32"
 Net Weight 2300 lbs.
 Footprint 19" x 51½"

Capacities:

Maximum Board Width..... 36"
 Maximum Board Thickness..... 6"
 Minimum Board Length..... 14"
 Minimum Board Thickness..... 1/8"
 Belt Speed..... 2600 FPM
 Conveyor Speed 15-49 FPM
 Dust Ports (3)..... 4"

Sanding Drum Motor:

Type TEFC Capacitor Start Induction
 Horsepower 10 HP
 Voltage / Phase / Cycle..... 220V/ Single-Phase / 60 HZ
 Amps 50 A
 RPM 1725 RPM
 Power Transfer to Drums Triple V-Belt

Conveyor Feed Motor:

Type TEFC Capacitor Start Induction
 Horsepower 1 HP
 Voltage / Phase / Cycle..... 220V / Single-Phase / 60 HZ
 Amps 7 A
 RPM 1725
 Power Transfer..... V-Belt

Table Lift Motor:

Type TEFC Capacitor Start Induction
 Horsepower 1/3 HP
 Voltage / Phase / Cycle..... 220V / Single-Phase / 60 HZ
 Amps 3 A
 RPM 1725
 Power Transfer..... V-Belt

General Construction:

Cabinet..... Steel
 Operating Air Pressure..... 75 PSI
 Sanding Belt Oscillation Adjustable
 Sanding Belt Brake Air Disc Brake
 Control Panel Push Button for each motor, plus load sensor
 Sanding Belt..... 36" x 60"

Specifications, while deemed accurate, are not guaranteed.

SECTION 3: SAFETY

WARNING

For Your Own Safety, Read Instruction Manual Before Operating this Machine

The purpose of safety symbols is to attract your attention to possible hazardous conditions. This manual uses a series of symbols and signal words which are intended to convey the level of importance of the safety messages. The progression of symbols is described below. Remember that safety messages by themselves do not eliminate danger and are not a substitute for proper accident prevention measures.

 **DANGER** Indicates an imminently hazardous situation which, if not avoided, WILL result in death or serious injury.

 **WARNING** Indicates a potentially hazardous situation which, if not avoided, COULD result in death or serious injury.

 **CAUTION** Indicates a potentially hazardous situation which, if not avoided, MAY result in minor or moderate injury. It may also be used to alert against unsafe practices.

NOTICE This symbol is used to alert the user to useful information about proper operation of the machine.

WARNING

Safety Instructions for Machinery

- 1. READ THROUGH THE ENTIRE MANUAL BEFORE STARTING MACHINERY.** Machinery presents serious injury hazards to untrained users.
- 2. ALWAYS USE ANSI APPROVED SAFETY GLASSES WHEN OPERATING MACHINERY.** Everyday eyeglasses only have impact resistant lenses, they are NOT safety glasses.
- 3. ALWAYS WEAR AN ANSI APPROVED RESPIRATOR WHEN OPERATING MACHINERY THAT PRODUCES DUST.** Wood dust is a carcinogen and can cause cancer and severe respiratory illnesses.
- 4. ALWAYS USE HEARING PROTECTION WHEN OPERATING MACHINERY.** Machinery noise can cause permanent hearing damage.
- 5. WEAR PROPER APPAREL. DO NOT** wear loose clothing, gloves, neckties, rings, or jewelry which may get caught in moving parts. Wear protective hair covering to contain long hair and wear non-slip footwear.
- 6. NEVER OPERATE MACHINERY WHEN TIRED, OR UNDER THE INFLUENCE OF DRUGS OR ALCOHOL.** Be mentally alert at all times when running machinery.

WARNING

Safety Instructions for Machinery

7. **ONLY ALLOW TRAINED AND PROPERLY SUPERVISED PERSONNEL TO OPERATE MACHINERY.** Make sure operation instructions are safe and clearly understood.
8. **KEEP CHILDREN AND VISITORS AWAY.** Keep all children and visitors a safe distance from the work area.
9. **MAKE WORKSHOP CHILD PROOF.** Use padlocks, master switches, and remove start switch keys.
10. **NEVER LEAVE WHEN MACHINE IS RUNNING.** Turn power OFF and allow all moving parts to come to a complete stop before leaving machine unattended.
11. **DO NOT USE IN DANGEROUS ENVIRONMENTS.** DO NOT use machinery in damp, wet locations, or where any flammable or noxious fumes may exist.
12. **KEEP WORK AREA CLEAN AND WELL LIT.** Clutter and dark shadows may cause accidents.
13. **USE A GROUNDED EXTENSION CORD RATED FOR THE MACHINE AMPERAGE.** Undersized cords overheat and lose power. Replace extension cords if they become damaged. DO NOT use extension cords for 220V machinery.
14. **ALWAYS DISCONNECT FROM POWER SOURCE BEFORE SERVICING MACHINERY.** Make sure switch is in OFF position before reconnecting.
15. **MAINTAIN MACHINERY WITH CARE.** Keep blades sharp and clean for best and safest performance. Follow instructions for lubricating and changing accessories.
16. **MAKE SURE GUARDS ARE IN PLACE AND WORK CORRECTLY BEFORE USING MACHINERY.**
17. **REMOVE ADJUSTING KEYS AND WRENCHES.** Make a habit of checking for keys and adjusting wrenches before turning machinery ON.
18. **CHECK FOR DAMAGED PARTS BEFORE USING MACHINERY.** Check for binding and alignment of parts, broken parts, part mounting, loose bolts, and any other conditions that may affect machine operation. Repair or replace damaged parts.
19. **USE RECOMMENDED ACCESSORIES.** Refer to the instruction manual for recommended accessories. The use of improper accessories may cause risk of injury.
20. **DO NOT FORCE MACHINERY.** Work at the speed for which the machine or accessory was designed.
21. **SECURE WORKPIECE.** Use clamps or a vise to hold the workpiece when practical. A secured workpiece protects your hands and frees both hands to operate the machine.
22. **DO NOT OVERREACH.** Keep proper footing and balance at all times.
23. **MANY MACHINES WILL EJECT THE WORKPIECE TOWARD THE OPERATOR.** Know and avoid conditions that cause the workpiece to "kickback."
24. **ALWAYS LOCK MOBILE BASES (IF USED) BEFORE OPERATING MACHINERY.**
25. **BE AWARE THAT CERTAIN WOODS MAY CAUSE AN ALLERGIC REACTION** in people and animals, especially when exposed to fine dust. Make sure you know what type of wood dust you will be exposed to and always wear an approved respirator.

WARNING

Additional Safety for Wide Belt Sanders

- 1. INFEEED/OUTFEED AREA:** When feeding the workpiece into the machine, keep clear of kickback path.
- 2. WORKPIECE FEEDING:** Never force the workpiece into the sander, and feed only one workpiece at a time.
- 3. CLOTHING:** Roll up or button sleeves, tie all loose clothing or hair so it will keep clear of entanglement hazards.
- 4. NARROW WORKPIECES:** Never sand workpieces narrower than $\frac{1}{8}$ ".
- 5. THIN WORKPIECES:** Never sand workpieces thinner than $\frac{1}{8}$ ".
- 6. SHORT WORKPIECES:** Never sand workpieces shorter than 14".
- 7. HANDS:** Never place hands near, or in contact with, sanding drums or conveyor belt during operation.
- 8. MAINTENANCE:** Perform machine inspections and maintenance service at the appropriate time intervals.
- 9. POWER AND AIR DISCONNECT:** Unless specifically stated in the manual, always disconnect the power source from the machine when performing maintenance, adjustments, or assembly. Always read and follow specific safety instructions for each section.
- 10. UNATTENDED MACHINE:** Never leave the machine running unattended.
- 11. SANDPAPER:** Replace sanding belt when it becomes worn or damaged.
- 12. FOREIGN MATERIAL:** Always inspect workpiece for nails, staples, knots, and other imperfections that could be dislodged and thrown from the machine during sanding operations.
- 13. DUST COLLECTION:** Never operate the sander without an adequate dust collection system in place and running.
- 14. ALLERGIES:** Certain woods may cause an allergic reaction in people and animals, especially when exposed to fine dust. Make sure you know what type of wood dust you will be exposed to and always wear an approved respirator.
- 15. ACCESS DOORS:** Never perform sanding operations when the side access doors are open.
- 16. UNDERSTAND INSTRUCTIONS:** Never allow unsupervised or untrained personnel to operate the machine. Make sure any instructions you give in regards to machine operation are approved, correct, safe, and clearly understood.

WARNING

Unfamiliarity with this manual could result in serious personal injury. Spend a sufficient amount of time becoming familiar with the contents of this manual, including all the safety warnings.

WARNING

No list of safety guidelines can be complete. Operating this machinery may require additional safety precautions specific to your shop environment. Failure to use reasonable caution while operating this machine could result in serious personal injury.

SECTION 4: CIRCUIT REQUIREMENTS

220V & 440V Operation

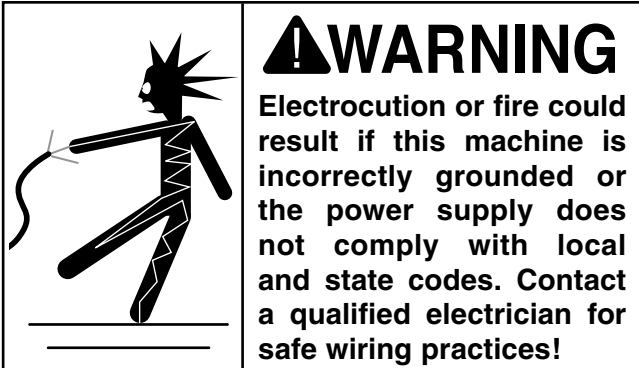

The following list outlines the electrical phase and voltage required to operate the various sander models, as well as the amperage draw of their motors:

G0571—220V, Single-Phase ~60 Amp

10 HP Sanding Motor	50 Amps
1 HP Feed Motor	7 Amps
1/3 HP Table Motor	3 Amps

G0446/G0539—220V, Three-Phase ~40 Amp

15 HP Spindle Motor	36 Amps
1 HP Feed Motor	3.4 Amps
1/4 HP Table Motor	1.2 Amps

G0446/G0539—440V, Three-Phase ~20 Amp

15 HP Spindle Motor	18 Amps
1 HP Feed Motor	1.7 Amps
1/4 HP Table Motor	0.6 Amps

Only connect your machine to a circuit that meets the requirements below. Always check to see if the wires and circuit breaker in your circuit are capable of handling the amperage draw from your machine, as well as any other machines that could be operating on the same circuit. If you are unsure, consult a qualified electrician.

Circuit Breaker List

G0571, 220V Single-Phase	60 Amp, 2 Pole
G0539, 220V Three-Phase	40 Amp, 3 Pole
G0539, 440V Three-Phase	20 Amp, 3 Pole
G0446, 220V Three-Phase	40 Amp, 3 Pole
G0446, 440V Three-Phase	20 Amp, 3 Pole



Connection Type

Hard wire this machine to your power panel and install an electrical box with a locking shut-off lever (**Figure 6**).

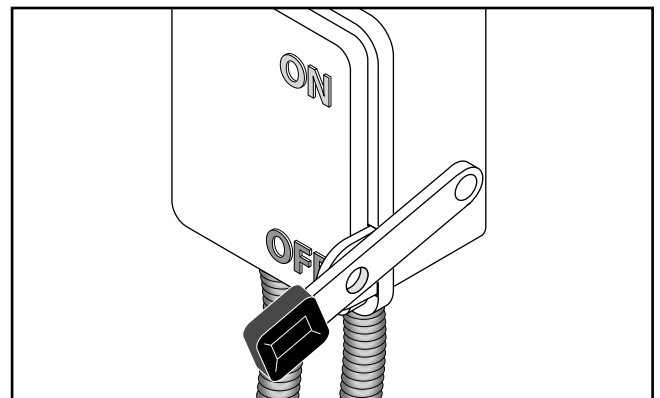
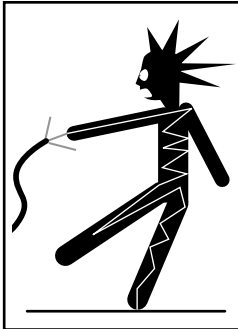

Figure 6. Locking Shut-Off Lever.

Note: If you do not have three-phase power available to the G0446/G0539 sander, you will have to install a phase converter such as the Grizzly H3741 Phase Converter.



Grounding

	<p>⚠️ WARNING Electrocution or a fire can result if the sander is not grounded correctly. Make sure all electrical circuits are grounded. DO NOT use the machine if it is not grounded.</p>
---	---

In the event of an electrical short, grounding provides electric current a path of least resistance to reduce the risk of electrical shock to the operator. Ground the power cord and this machine in accordance with all local codes and ordinances.

Operating this machine when it is not properly grounded can result in electric shock or electrocution.



Extension Cords

Because of the high amperage draw from this machine, we do not recommend the use of extension cords. Using extension cord will increase the high amperage electrocution and fire hazard. Instead, position your equipment near installed wiring to eliminate the need for extension cords.



440V Connection (G0446/G0539)

To connect this machine to 440V three-phase, you must purchase one LR3D-076 overload relay and one LR3D-3322 overload relay.

If you do not have three-phase power available to the G0446/G0539 sander, you will have to install a phase converter such as the Grizzly H3741 Phase Converter.

When using a phase converter, the power from the manufactured power leg (sometimes called the wild wire) can fluctuate. Connect the manufactured power leg to the S terminal to prevent damage to the transformer. The wire from the S terminal can handle some fluctuation because it goes directly to the motor. The power going to the R and T terminals goes to the transformer and must be consistent to prevent damage.

To wire the Model G0446/G0539 to 440V:

1. **Disconnect the sander from the power source!**
2. Open the electrical box located on the back of the machine.
3. Remove the wire labeled "1" at the 220V terminal of the control power transformer (**Figure 7**) and connect it to the 440V terminal.

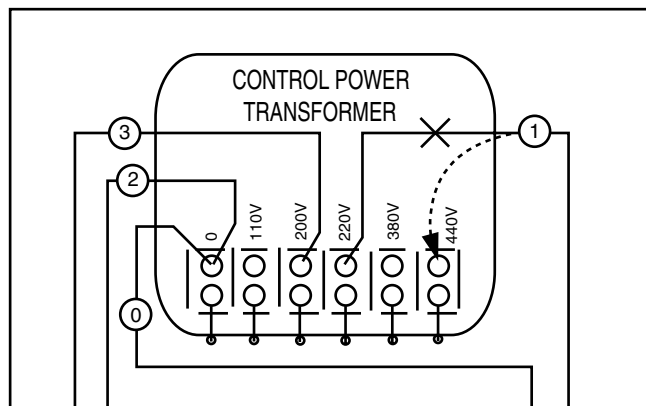

Figure 7. The "1" wire should be connected to the 440V terminal.

4. Remove the LR3D-3355 overload relay (**Figure 8**), and replace it with an LR3D-3322 (17-25A) type, with the dial set to 18A.

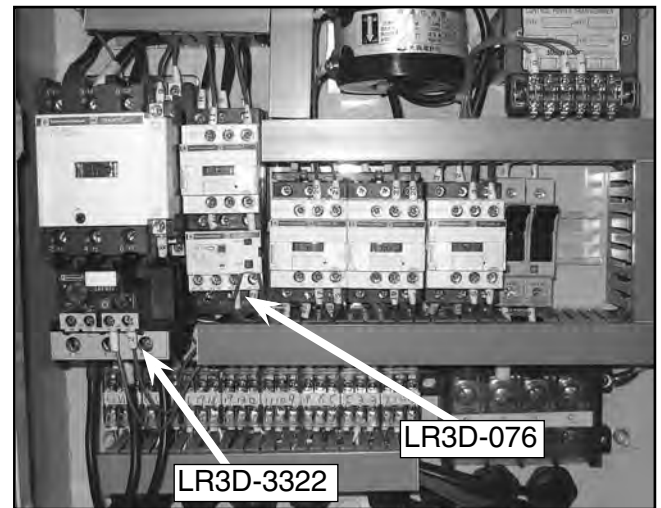

Figure 8. Overload relay.

5. Remove the LR3D-086 overload relay (**Figure 8**), and replace it with an LR3D-076 (1.6-2.5A) type, with the dial set to 1.7A.
6. Wire the sanding belt, conveyor belt, and table elevation motors as shown on the diagrams on the inside of each motor wire cover.

Note: The circled references on the diagrams represent labels on the wires. Also, **Figure 9** below has been provided for your reference and is current at the time of writing. However, always use the diagram on the wire cover that comes with your motor!

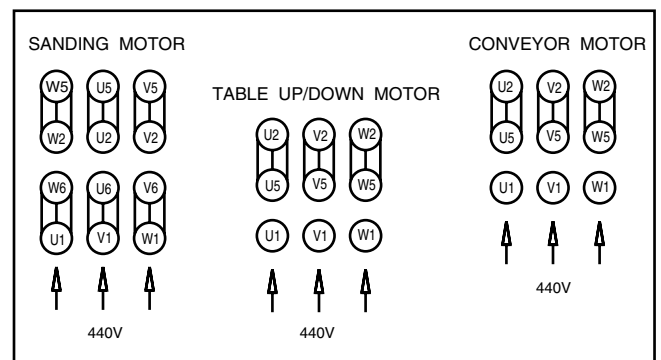
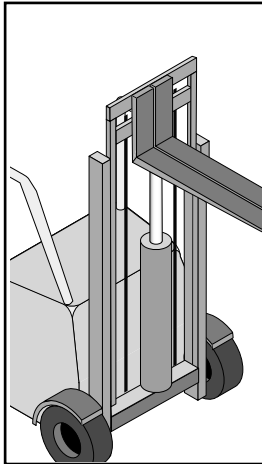

Figure 9. 440V motor wiring connection.



SECTION 5: SET UP

Unpacking



⚠ WARNING

The Model G0446/G0539/G0571 is a heavy machine weighing in at one ton. Personal injury can occur if the machine is moved without appropriate machinery. Use a crane or forklift when moving or lifting the machine.

The Model G0446/G0539/G0571 was carefully packed when it left our warehouse. If you discover the machine is damaged after you have signed for delivery, please immediately call Customer Service at (570) 546-9663 for advice.

Save the containers and all packing materials for possible inspection by the carrier or its agent. Otherwise, filing a freight claim can be difficult.

When you are completely satisfied with the condition of your shipment, you should inventory the contents.

NOTICE

A parts diagram and parts list are located near the end of the manual. Use the diagram and list to identify missing parts or to supplement the assembly instructions provided in this manual.



Inventory

Crate contents, see Figure 10.

- A. Sanding Unit (Not Pictured)
- B. (3) Dust Ports 4"
- C. Sanding Belt 100 Grit
- D. Sanding Belt 180 Grit
- E. (2) Platen Graphite Flap
- F. Platen Felt
- G. Tool Box
 - Phillips Head Screwdriver #2
 - Standard Screwdriver #2
 - Open-End Wrench 8/10mm
 - Open-End Wrench 12/14mm
 - Open-End Wrench 17/19mm
 - Metric Hex Wrench Set 10 Pcs.
 - (2) Door Keys
 - (2) Ceramic Limit Switch Rub Rods
 - (1) Flexible Grease Gun Extension
 - (1) Graphite Holder Bar

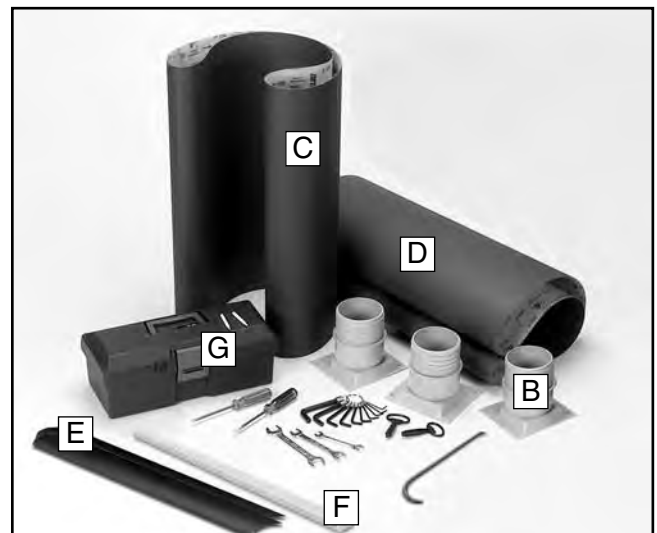















Figure 10. Parts layout.



Hardware Chart

USE THIS CHART TO MATCH UP HARDWARE DURING THE ASSEMBLY PROCESS!

MEASURE BOLT DIAMETER BY PLACING INSIDE CIRCLE

-  #10
-  1/4"
-  5/16"
-  3/8"
-  7/16"
-  1/2"
-  5/8"
-  4mm
-  6mm
-  8mm
-  10mm
-  12mm
-  16mm

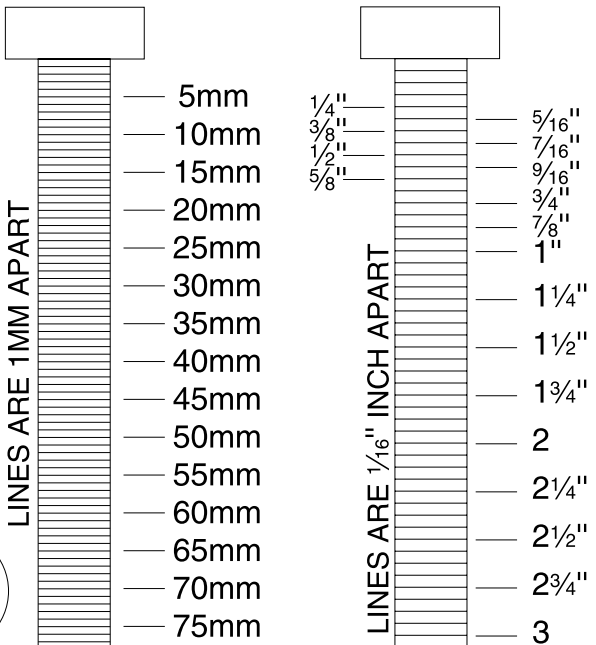
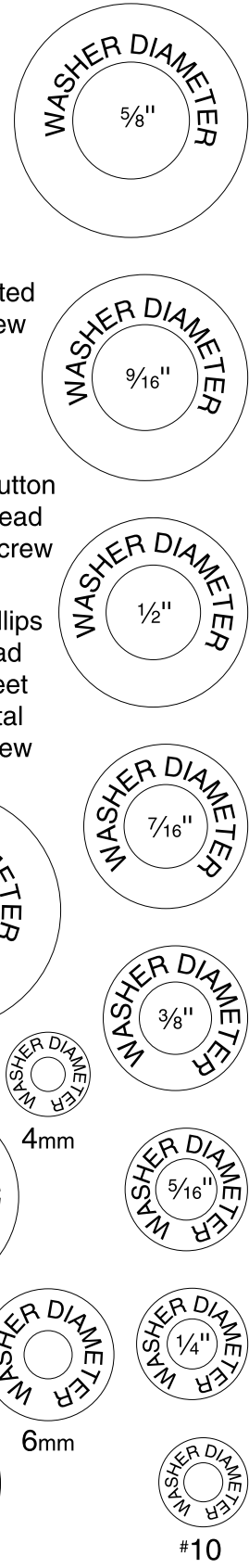
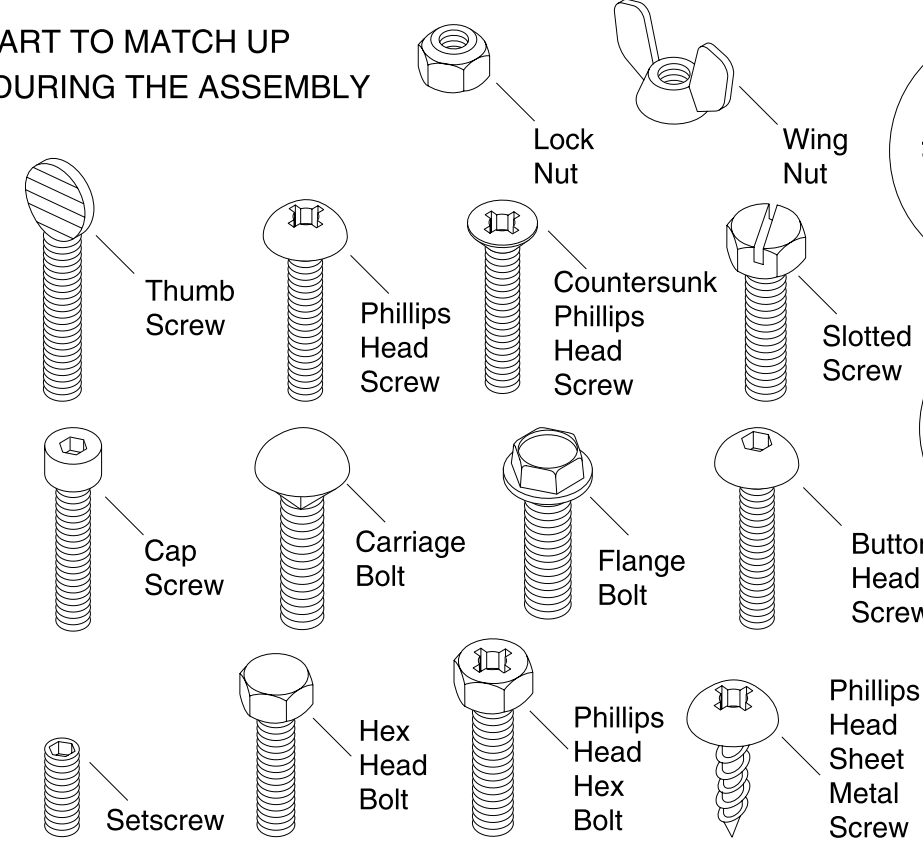

WASHERS ARE MEASURED BY THE INSIDE DIAMETER

Clean Up

Any unpainted surfaces are coated with a waxy oil to protect them from corrosion during shipment. Remove this protective coating with a solvent cleaner or citrus-based degreaser such as Grizzly's G7895 Degreaser. To clean thoroughly, some parts may need to be removed. **For optimum performance from your machine, make sure you clean all moving parts or sliding contact surfaces that are coated.** Avoid chlorine-based solvents as they may damage painted surfaces should they come in contact.

	<p>⚠️ WARNING Gasoline and petroleum products have low flash points and could explode if used to clean machinery. DO NOT use gasoline or petroleum products to clean the machinery.</p>
---	---

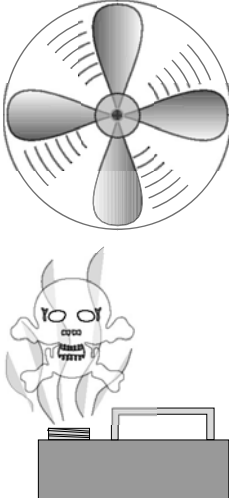
	<p>⚠️ WARNING Lack of ventilation while using solvents could cause serious personal health risks, fire, or environmental hazards. Always work in a well ventilated area to prevent the accumulation of dangerous fumes. Supply the work area with a constant source of fresh air.</p>
---	--



Site Considerations

Floor Load

The Model G0446/G0539/G0571 is a large load in a medium footprint. Most commercial or home shop floors should be sufficient to carry the weight of the machine. If you question the strength of your floor, have it inspected by a building code inspector.

Working Clearance

Working clearances can be thought of as the distances between machines and obstacles that allow safe operation of every machine without limitation. Consider existing and anticipated machine needs, size of material to be processed through each machine, and space for auxiliary stands and/or work tables. Also, consider the relative position of each machine to one another for efficient material handling. Be sure to allow yourself sufficient room to safely run your machines in any foreseeable operation and keep dust collection hoses off the floor and out of the way.

Lighting

Lighting should be bright enough to eliminate shadows and prevent eye strain. Electrical circuits should be dedicated or large enough to handle combined motor amp loads. Be sure to observe local electrical codes for proper installation of new lighting or circuits.

	<p>⚠️ WARNING Unsupervised children and visitors entering a shop could suffer serious personal injury. Ensure child and visitor safety by keeping all entrances to the shop locked at all times. DO NOT allow unsupervised children or visitors in the shop at any time.</p>
--	--





Beginning Assembly

This section will cover the basic assembly and adjustment instructions needed to begin operation. Complete the assembly in the order provided in this manual and then read the remaining portion of the manual before attempting any type of operation.

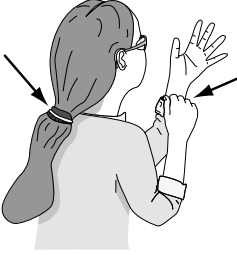
Your safety is important! Please follow the warnings below during this entire section:

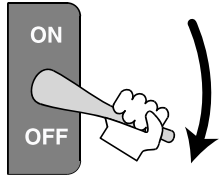
	<p>⚠ WARNING</p> <p>Loose hair and clothing could get caught in machinery and cause serious personal injury. Keep loose clothing rolled up and long hair tied up and away from machinery.</p>
---	--

	<p>⚠ WARNING</p> <p>Disconnect power to the machine during the entire assembly process. Failure to do this may result in serious personal injury.</p>
---	--

	<p>⚠ CAUTION</p> <p>Sharp edges on metal parts may cause personal injury. Examine the edges of all metal parts before handling.</p>
---	--



Floor Mounting

To mount the sander to the floor:

The sander needs to be mounted in a level location where it can be easily serviced from all sides. Also, consider the largest workpiece you might need to sand before deciding on a final position.

Mount the sander to wooden floors with 1/2" lag bolts and washers. Mount the sander to concrete floors with 1/2" anchor-style bolts designed for concrete applications. **Note:** Be sure to carefully follow the anchor bolt manufacturer's instructions.



Air Line Installation

To install the air line:

1. Connect the hose from your air compressor to the air inlet (**Figure 11**) on the regulator.

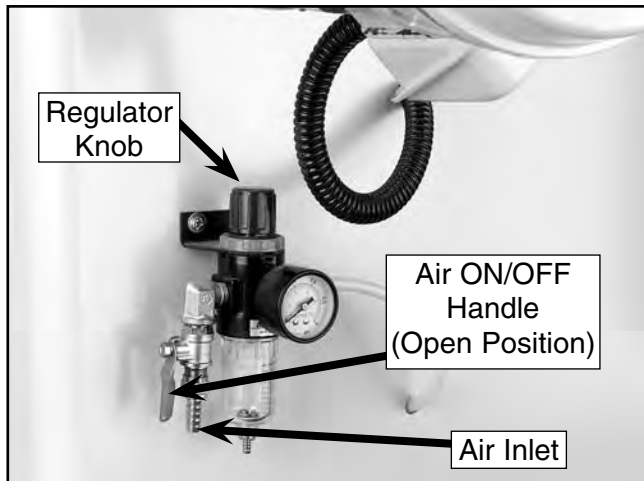

Figure 11. Air inlet located on regulator.

2. Make sure the red handle on the regulator is in the open position (parallel with the air inlet).
3. Lift the regulator knob (**Figures 11** and **12**) and turn it until the air pressure gauge reads 75 PSI. **Note:** Turn the knob clockwise to increase the air pressure and counterclockwise to lower the air pressure.
4. Push the regulator knob down until it snaps.

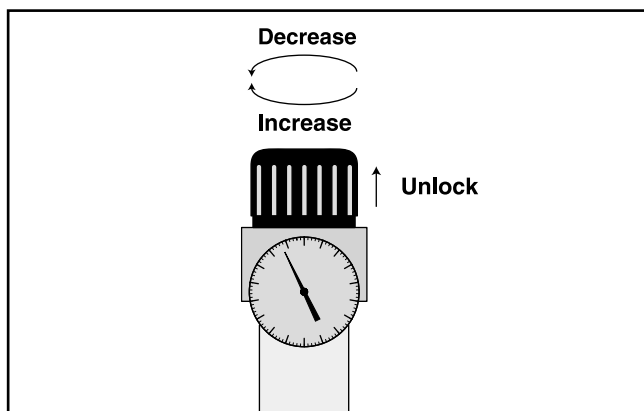

Figure 12. Regulator knob.



Dust Collection

An efficient and clean dust collection system is essential to the proper function of the sander. Ensuring a healthy work environment is also dependent upon cleaning and maintaining your dust collection system. For this machine we recommend a minimum of 1200 CFM.

To hook up a dust collection system:

1. Install the three 4" dust ports (**Figure 13**) to the mounting locations on the top of the sanding unit with the supplied M6-1.0 x 10 Phillips head screws.

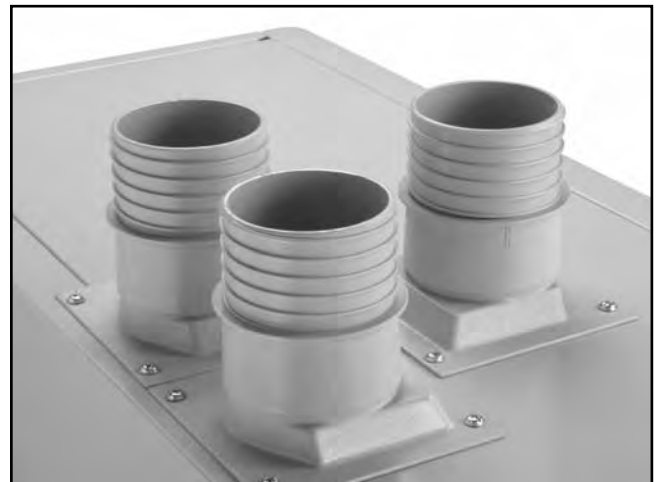

Figure 13. 4" dust ports.

2. Clamp three 4" hoses from your dust collection system to the dust ports.



Sanding Belt

To install the sanding belt:

1. **Disconnect the sander from the power source!**
2. De-activate the belt tension piston by turning the roller tension switch (**Figure 14**).



Figure 14. Roller tension switch.

3. Remove the lock post release lever (**Figure 15**) by turning it counterclockwise $\frac{1}{2}$ turn and pulling it up and out of the mounting hole.

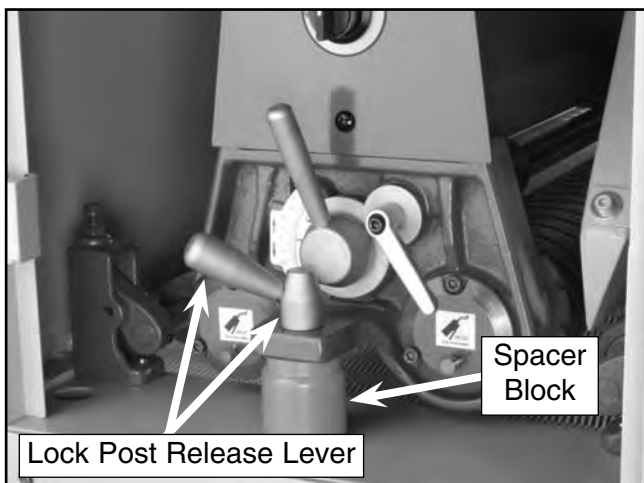

Figure 15. Components used when changing a sanding belt.

4. Remove the spacer block (**Figure 15**).
5. Install the sanding belt by starting first on the upper roller, and then the lower roller.

Note: The sanding belt must be centered between the limit switches and the edge of the sanding belt must be between tongs of the oscillation controller as shown in **Figure 16**. Damage to the sanding belt could occur if the sander is turned **ON** before the sanding belt is correctly positioned.

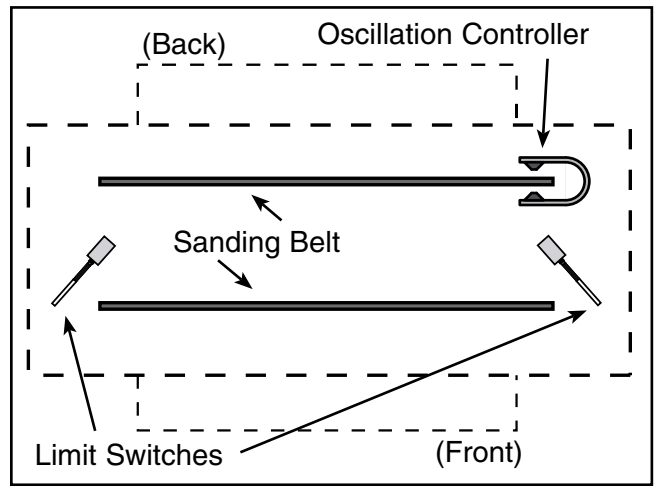

Figure 16. Sander Outline (Top View). Proper position of belt between the limit switches.

NOTICE

The directional arrow on the back of the sanding belt must be pointing in a counterclockwise direction during installation. Failure to install the sanding belt correctly could result in damage to the sanding belt or the sander itself.

6. Replace the spacer block and tighten down the lock handle bolt.
7. With your hands clear of all moving parts, tension the belt by turning the roller tension switch.



Pressure Rollers

The pressure rollers have been set at the factory, but for safety, you should verify that they are set below the level of the sanding roller.

WARNING

It is absolutely essential to keep the pressure rollers set below the level of the sanding roller. If the pressure rollers are even, or higher than the sanding roller, the wood **WILL** be propelled from the sander at a high rate of speed. This situation could cause serious personal injury.

To check the pressure roller height:

1. **Disconnect the sander from the power source!**
2. Place a piece of scrap wood of uniform thickness across the table so it spans both the front and the rear pressure rollers at the same time.
3. With the air pressure connected and the sanding belt installed and tensioned, manually raise the table and verify that the board touches both pressure rollers before it touches the sanding belt.

Note: If the board does not touch both pressure rollers before it touches the sanding belt, then the pressure rollers must be adjusted before operation. See "Pressure Rollers" on **Page 35** for Step-by-Step instructions on how to do this.



Start Up

WARNING

Serious personal injury could result if the machine is connected to the power source during assembly or adjustment. Wait until the machine is turned off, unplugged, and all working parts have come to a complete stop before you attempt to assemble or adjust the machine!

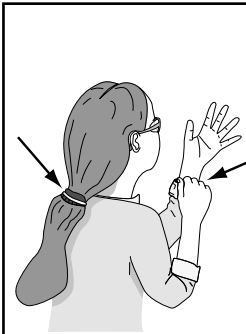

WARNING

Loose hair and clothing could get caught in machinery causing serious personal injury. Keep loose clothing rolled up and long hair tied up and away from machinery.



WARNING

Projectiles thrown from the machine could cause serious eye injury. Wear safety glasses during start up.

Before starting the machine:

1. Read this manual and make sure you take all safety precautions before operating this machine.
2. Make sure the machine is connected to an air compressor and the pressure gauge reads 75 PSI.
3. Make sure all tools or foreign objects have been removed from the conveyor surface, top of the machine, and the inside of the machine.
4. Make sure all the wiring is correct.

To start the machine:

1. **Wear safety glasses at all times when running the machine!**
2. Connect the machine to the power source.
3. Press the TABLE UP and TABLE DOWN keys. The table should go up and down smoothly.

Note: Make sure the table moves in the same direction as the button description. If not, then the power needs to be disconnected and any two power wires need to be switched at the circuit breaker in the electrical box. If using a phase converter, switch the R and T wires.

4. Press the FEED BELT START and FEED BELT STOP buttons. The feed belt should start, run, and stop smoothly.
5. Press the SANDING BELT START and SANDING BELT STOP buttons. The sanding belt should start, run, and stop smoothly.

The machine should run smoothly, with little or no vibration or rubbing noises. Strange or unnatural noises should be investigated and corrected before operating the machine further.

If the machine seems to be running correctly, let it run for a short time to ensure that the moving parts are working properly with no excessive vibration. **DO NOT** operate the machine if problems cannot be corrected.

If you cannot locate the source of unusual noises, refer to **Troubleshooting**, and feel free to contact our Technical Support Department at (570) 546-9663.



Recommended Adjustments

For your convenience, the adjustments listed below have been performed at the factory and require no further adjustment. However, we recommend that you verify that the adjustments are correct and to your satisfaction.

Recommended adjustment checklist:

- Table Calibration
- Feed Belt Tension
- Feed Belt Tracking
- Air Regulator to 75 PSI
- Oscillation Timing
- Oscillation Speed
- Pressure Rollers
- Table Parallelism
- V-Belt Adjustment



SECTION 6: OPERATIONS

Operation Safety

Your safety is important! Please follow the warnings below during this entire section:

WARNING

To avoid serious personal injury, read and become familiar with the entire instruction manual before using this wide belt sander.

WARNING

Damage to your eyes, lungs, and ears could result from failure to wear safety glasses, a dust mask, and hearing protection while sanding with this machine.

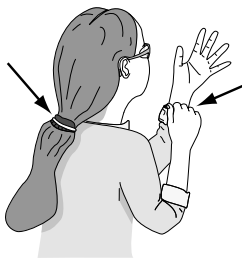
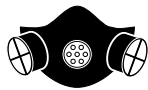

WARNING

Loose hair and clothing could get caught in machinery and cause serious personal injury. Keep loose clothing rolled up and long hair tied up and away from machinery.



Choosing Sandpaper

The grit you choose will depend on the type of work, the species of wood and the stage of finishing. Below is a chart that groups abrasives into different categories and shows which grits fall into each-one. We recommend using aluminum oxide sanding belts for the best results.

Grit	Type
60	Coarse
80-100	Medium
120-150	Fine

The general rule of thumb is to sand a workpiece with progressively higher grit numbers, with no one grit increase of more than 50; however, the type of wood and desired finish will determine the best grit to use.



Table Movement

Table height can be adjusted manually or with the digital key pad and motor, see **Figure 17**.

Manual Table Movement—Turn the handwheel located under the front of the infeed table for manual table positioning.

Motorized Table Movement—Press the TABLE UP or TABLE DOWN key once for motorized table positioning in 0.005" (0.1mm) increments.

Numerical Key Pad—Enters the position of sanding depth digitally.

Metric or Standard Key—Press and hold the SET button for 3 seconds to calibrate display at the current board thickness; or press and hold key for 10 seconds to toggle the display between metric and standard measurement.

Table Start Key—Moves table to a preset sanding depth.

Table Stop Key—Stops table movement immediately.

Digital Display—Shows final table sanding depth.

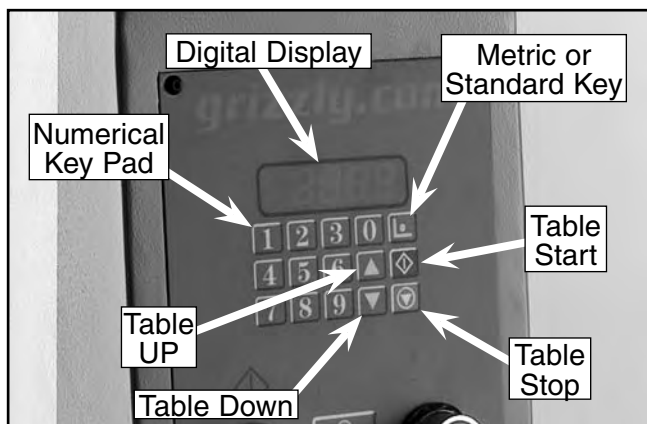

Figure 17. Keys for adjusting the table height.

NOTICE

The thickness gauge is pre-calibrated from the factory; however, correct calibration should be verified.



Adjusting Feed Rate

The dial attached to the side of the feed belt gear box (**Figure 18**) adjusts the feed rate of the sander.

Note: Never adjust the feed rate dial unless the conveyor belt is running, otherwise you can damage the control.

Changing Feed Rate—Turn the dial clockwise to decrease the feed rate and counterclockwise to increase it. The feed rate is variable between 15-49 FPM.

Determining Ideal Feed Rates—Softwoods typically require a faster feed rate than hardwoods; however, there is no definitive rule to follow when determining the best feed rate. As a general rule, always start with the slowest feed rate and work your way up. We always recommend testing the feed rate using scrap wood similar to your workpiece. Be sure to monitor the amperage meter when adjusting the feed rate. Decrease the feed rate if the load begins to slow the motor RPM.

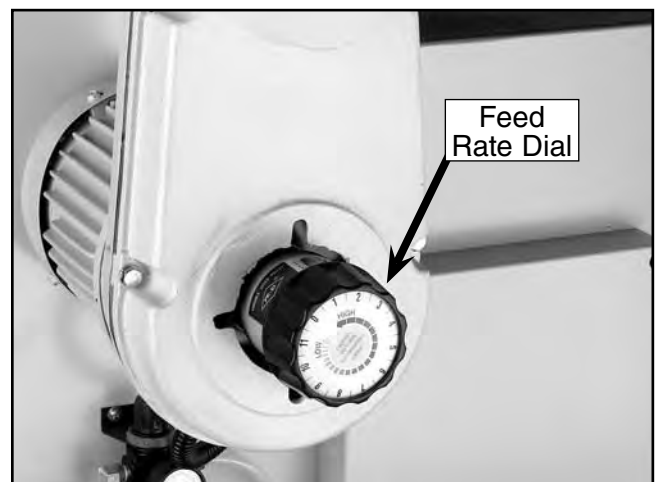

Figure 18. Feed rate dial.



Amp Draw Meter

The amperage draw meter (**Figure 19**) is located above the control panel. Use the meter to monitor the amperage draw on the machine while performing sanding operations.

As a general rule, always start with a small load and work your way up. DO NOT work your machine to its maximum load where you can hear the motor lose RPM; instead, make multiple passes or install a coarser grit paper.

Amp load will be directly affected by many factors such as feed rate, depth of cut, wood type, sandpaper grit, and workpiece width. If the amp load is in the red load range, the machine is overloaded and motor damage will occur. Keep the amp load in the green range during operation.



Figure 19. Amperage meter.

NOTICE

DO NOT VOID WARRANTY! Keep the amp draw within the GREEN load range shown on the AMP LOAD CHART. If you operate the sander in the RED load range, capacitor or motor failure will occur and will not be covered under warranty.



Sanding Workpiece

Typically, no more than 0.5mm (approx. $\frac{1}{64}$ ") of material is removed during each pass. Attempts to remove too much material can cause jamming, wood burning, rapid paper wear or tearing, poor finish, short motor life, and belt slippage.

The following is the correct sanding operating procedure:

1. Turn **ON** the dust collector.
2. **Wear safety glasses, a dust mask, and hearing protection!**
3. On the initial pass, set the table to approximately $\frac{1}{4}$ " greater than the thickness of the workpiece.

Note: This initial pass setting reduces the chance of overloading the sander on undetected high points on the workpiece.

4. Continue to raise the table $\frac{1}{16}$ " between each successive pass until the sander begins to sand the workpiece.

NOTICE

It may be necessary to send wide stock through the sander two or three times between table height adjustments. This reduces the likelihood of burning the wood if there is a high spot.



Platen Adjustment

Your sander is equipped with an adjustable felt platen and graphite slip for those extra sensitive sanding operations. The platen position allows for 3 basic types of sanding. These different positions can be adjusted by rotating the height lever shown in **Figure 20**.

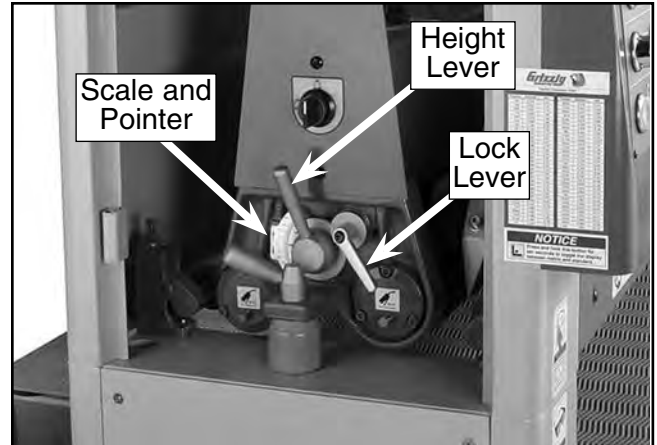

Figure 20. Platen height controls.

The three basic platen positions:

Platen Up — The platen is raised above the level of the sanding rollers. This position allows the front roller to remove large amounts of material quickly, but leaves a rough finish. The best belt grit for this position is #100 or coarser.

Platen Even — The platen is set even with the sanding rollers. The rollers work together with the platen to produce intermediate/final finishing. The best belt grit for this position is #100-#180.

Platen Down — The platen is lowered below the sanding rollers. The majority of the work is accomplished by the platen pressure on the workpiece. The result is a smooth, flat finish. The best belt grit for this position is #180 or finer. Avoid Lowering the platen more than 2MM below the sanding belt rollers.

Note: The platen scale is broken down in millimeter increments.



SECTION 7: ACCESSORIES

H2845 Cleaning Pads

Cleaning pads are the perfect accessory for wide belt sanders (**Figure 21**). Simply set the conveyor table to height and feed the pad through to “unload” a dirty sanding belt. Regular cleaning greatly increases the lifespan of sanding belts. Check with the current Grizzly catalog or www.grizzly.com for more details.



Figure 21. Sanding belt cleaning pad.

37" Wide x 60" Long Sanding Belts:

These excellent “Y” Weight polyester backing abrasive belts are direct replacements for your wide belt sander:

G7998 Aluminum Oxide	60 Grit
G7999 Aluminum Oxide	80 Grit
G8000 Aluminum Oxide	100 Grit
G8001 Aluminum Oxide	120 Grit
G8002 Aluminum Oxide	150 Grit

H3741 30 HP Rotary Phase Converter

Add 3-phase, multi-motor capability to your single-phase electrical supply (**Figure 22**). Operate single or multiple motors, transformers, and resistance loads at 100% power and 95% efficiency while saving big dollars at cheaply metered, single-phase electrical rates. Complete step by step instructions are furnished along with complete wire and fusing requirements for various motor loads. Each model operates up to twice its nameplate rating in a mixed-motor load. On heavily loaded or hard-start applications, such as high-speed geared-head lathes and air conditioning compressors, the nameplate rating of the converter you choose should be 2 to 3 times the HP of the most heavily loaded motor. See the individual 3-phase machine pages for phase converter recommendations. For application assistance, please call our technical support at (570) 546-9663.

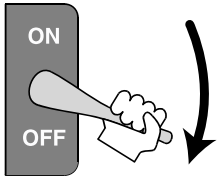

Figure 22. Rotary phase converter.

SECTION 8: MAINTENANCE

General

Your safety is important! Please follow the warnings below during this entire section:

	<p>!WARNING Disconnect power to the machine when performing maintenance, assembly or adjustments. Failure to do this may result in serious personal injury.</p>
---	--

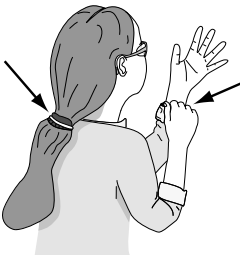
	<p>!WARNING Loose hair and clothing could get caught in machinery causing serious personal injury. Keep loose clothing rolled up and long hair tied up and away from machinery.</p>
--	--

	<p>!WARNING Wear safety glasses during the entire maintenance process. Failure to comply may result in serious personal injury.</p>
---	--



Schedule

The following items should be checked each time the sander is used.

- Loose mounting bolts.
- Damaged sanding belt.
- Worn or damaged wires.
- Water collection cups filled with water.
- Any other condition that could hamper the safe operation of this machine.
- Dust trap.

Weekly

Grease the grease fittings located on the feed belt roller axles and the sanding belt roller axles. They are identified with yellow labels.

Monthly

Apply a generous amount of grease to the table elevation screws. Be sure to recover the adjustment screws with the dust covers when finished.

Remove the lower side panel to access the table lifting mechanism. Apply grease to the chain and gears associated with the table lifting mechanism. Be careful to not get grease on the V-belts. This could cause them to slip off of the pulleys.

After the First 100 Hours

The oil inside the gear reducer should be replaced after the first 100 working hours of operation. We recommend 90 Wt. gear oil.

Every 2500 Hours

After the first gear reducer oil change, replace the oil after every 2500 working hours of operation. We recommend 90 Wt. gear oil.



Sanding Belts

You can greatly increase the lifespan of your sanding belts if you clean them often. As mentioned on **Page 26**, cleaning pads are the fastest way to remove saw dust build-up.



Air System

The air system is durable and reliable; however, components do wear with age. If you suspect that an item in your air system may be having problems, see the air line circuit on **Page 2**.

- Carefully inspect all air lines for cracks, tears or hardening. Replace faulty hoses.
- Check the air connections for leaks. A small amount of soapy water in a questionable area will bubble if there is a leak.
- Make sure lines are not clogged. Remove a questionable line and blow through it as a test.

CAUTION

If a component in the air system is malfunctioning, bleed all air from the system, and fix the problem before you resume sanding.



Dust and Water Traps

There are two traps on the Model G0446/G0539/G0571. One is attached to the bottom of the regulator (**Figure 23**) and the other is located inside the right access door (**Figure 24**). Empty the traps as they fill. The internal white filters should be replaced yearly.

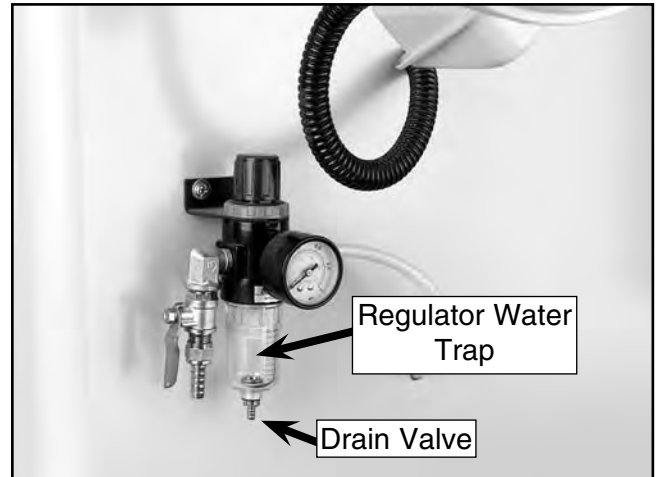

Figure 23. Push lower drain valve to empty the regulator water trap.

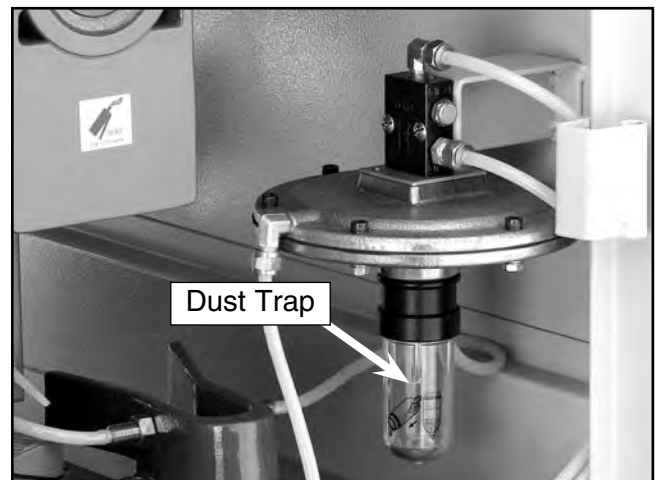

Figure 24. Unscrew the clear canister to empty the air line dust trap.



SECTION 9: SERVICE

Table Calibration

NOTICE

The digital thickness gauge has been calibrated at the factory and should require no further adjustment. However, we recommend verifying its accuracy.

Use the first board fed through the sander to test the accuracy of the digital thickness gauge.

To calibrate the digital thickness scale:

1. Using a properly set-up planer, plane a board to uniform thickness.
2. Lower the sander table far enough to place the planed board under the sander roller.
3. Manually raise the table until the board just touches the sanding roller.
4. Remove the board without changing the table height. This ensures the table will be properly adjusted for the first sanding pass.
5. Run the board through the sander several times at the initial height setting. Manually raise the table 0.020" and pass the board through the sander several more times. Monitor the amperage meter and the resulting load on the sander.
6. Measure the thickness at various points around the board using a precise micrometer or set of calipers. Continue sanding the board at that height until the average thickness measurement is within ± 0.003 ".

Note: These final passes should be done without adjusting the table height. This ensures the most consistent average thickness.

7. Observe the digital display read-out, it should indicate the average thickness of the sanded wood.

—If it does, the sander is properly calibrated and accurate to the nearest 0.005".

—If it doesn't, you must recalibrate the digital thickness scale.

To recalibrate the digital thickness scale:

1. Without moving the table height, enter the numerical measurement of the average thickness of the sanded wood into the digital key pad on the control panel.

Note: The average thickness of the sanded wood should now be flashing on the digital read-out.

2. Press and hold the  key until the display stops flashing. The sander is now correctly calibrated.



Brake Service

Tools Needed:	Qty
14mm Open End Wrench.....	1
Small Snap Ring Pliers	1
6mm Hex Wrench.....	1
#2 Phillips Screwdriver	1

Eventually the brake pads will wear out. Checking and replacing these is a simple project that can be done in the shop, with the exception of having the rotor resurfaced on a lathe.

To check the brake pads:

1. **Disconnect the sander from the power source and remove air pressure completely!**
2. Remove the four screws that secure the access panel on the right-hand side of the machine.
3. The brake caliper is located underneath the rotor in **Figure 25**, which is attached to the motor arbor.

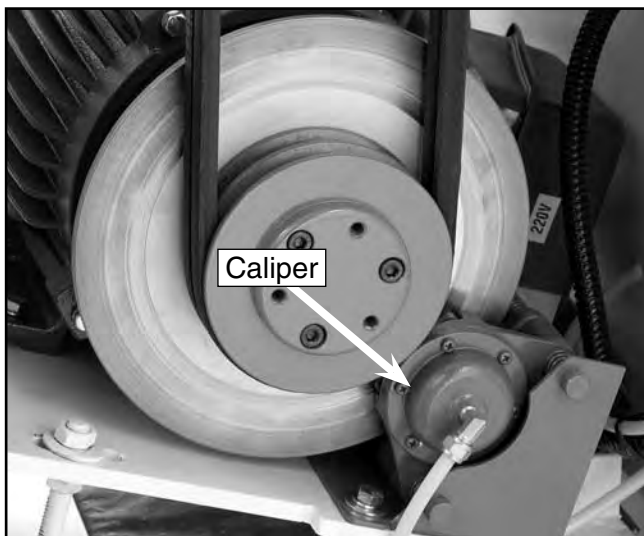

Figure 25. Disc brake.

4. The brake pads consist of a metal plate with a composite pad. With a fine ruler, measure the thickness of the composite pad only. If one of the pads is below $\frac{1}{8}$ " (approx. 3mm), replace both.

To replace the brake pads:

1. **Disconnect the sander from the power source and remove air pressure completely!**
2. Remove the nuts from the two mounting bolts and the two snap rings on the mounting pins behind the bracket.
3. Pull the mounting pins out of the caliper bracket and remove the air line from the caliper. The caliper should now be able to be removed.
4. Disassemble the break caliper and remove the cap screws securing the brake pads.
5. Remove the brake rotor and have it professionally resurfaced at an automotive machine shop if it has gouges in it. If visible cracks are present in the brake rotor, replace it with a new one. Remove oil and dirt from the rotor with automotive brake cleaner. Once clean, only handle the rotor with a dry rag and install exactly the reverse of removal.
6. Install new brake pads, mount the caliper and reconnect the air line.
7. Test the safety shutdown operation by running the sander and pressing the emergency stop controls.



Feed Belt Tension

Tools Needed:	Qty
20mm Wrench or Socket.....	1
#2 Phillips Screwdriver.....	1

To adjust the feed belt tension:

1. **Disconnect the sander from the power source!**
2. Find the adjustment ports in the safety guard (**Figure 26**) at the front end of the feed table.
3. Turn both left and right adjustment bolts (**Figure 26**) clockwise equally to increase tension.

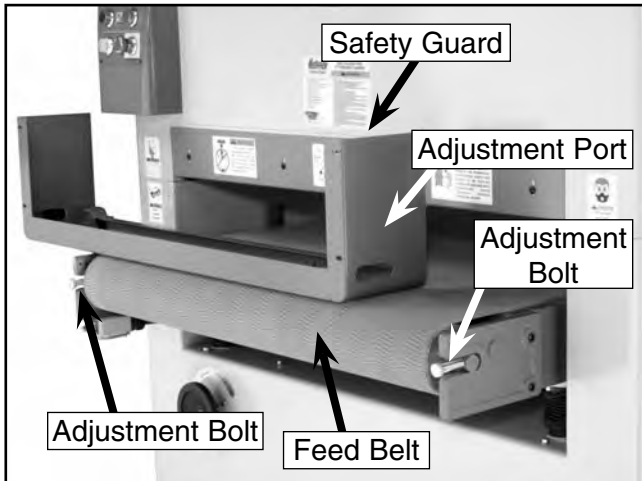

Figure 26. Feed belt tension adjustment bolts.

Note: Safety guard removed for clarity.

4. When tensioned properly you should not be able to lift the feed belt off the table surface or slide it back and forth.

!WARNING

DO NOT sand boards with the guard removed. Failure to follow this warning could result in serious personal injury.



Feed Belt Tracking

Tools Needed:	Qty
6mm Hex Wrench.....	1

NOTICE

Adjust the feed belt tension before adjusting the feed belt tracking.

To adjust the feed belt tracking:

1. Turn the feed belt ON.
2. If the feed belt is tracking to the **right** side of the table, turn the **right** adjustment bolt (**Figure 26**) clockwise.
3. If the feed belt is tracking to the **left** side of the table, turn the **left** adjustment bolt clockwise.

Note: The edge of the feed belt should just touch the guide wheels as shown in **Figure 27**.

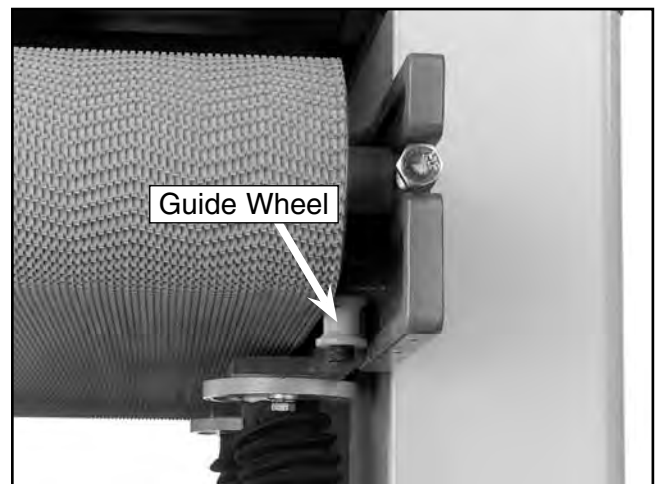

Figure 27. Guide wheels.

4. Run the feed belt for 3-5 minutes and recheck the tracking.
5. If the belt is still tracking correctly, replace the safety cover removed in the previous subsection.



Oscillation Timing

NOTICE

The oscillation adjustments have been performed at the factory and should require no further attention. However, we recommend verifying the settings.

When the oscillation is correctly adjusted, the sanding belt oscillates to the left and to the right at the same speed. If the sanding belt makes contact with a limit switch, as shown in **Figure 28**, the emergency braking system will activate and stop the sander immediately.

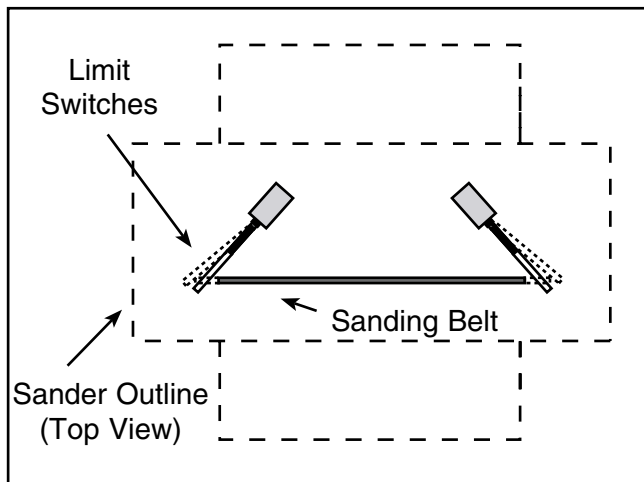

Figure 28. Improper oscillation.

To check the sanding belt oscillation:

1. Be sure the sanding belt is properly installed and the roller tension switch and air supply is **ON**.
2. Turn **ON** the sanding belt.

—If the belt oscillates without contacting the limit switches, but the oscillation time to the left and right are **NOT** equal, proceed to **Step 5, Page 33**.

—If the belt tracks away from the air fork and air jet, colliding into the limit switch, continue with **Step 3**.

3. An adequate stream of air through the air fork gap (**Figure 29**) is essential for proper oscillation. If the jet of air is weak through the gap, the belt will track away from the controller and into the limit switch on the opposite end of the roller. The pivot action of the upper roller, and the resulting oscillation of the belt, are dependent upon adequate airflow through the air fork gap.

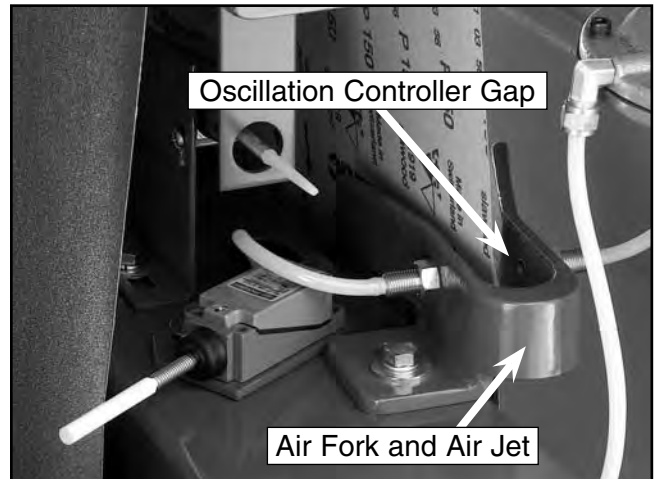

Figure 29. Oscillation components.

To set the correct amount of airflow through the air fork gap:

1. Remove the sanding belt and turn the roller tension switch to the tensioned position.
2. Loosen the lock nut on the airflow adjustment knob (**Figure 30**).
3. Turn the airflow adjustment knob clockwise until the airflow is completely off. The upper roller should pivot to the right.
4. Slowly turn the airflow adjustment knob counterclockwise, and continue turning up the air pressure until the roller pivots to the left.

5. Tighten the lock nut (**Figure 30**) to secure the airflow adjustment knob.

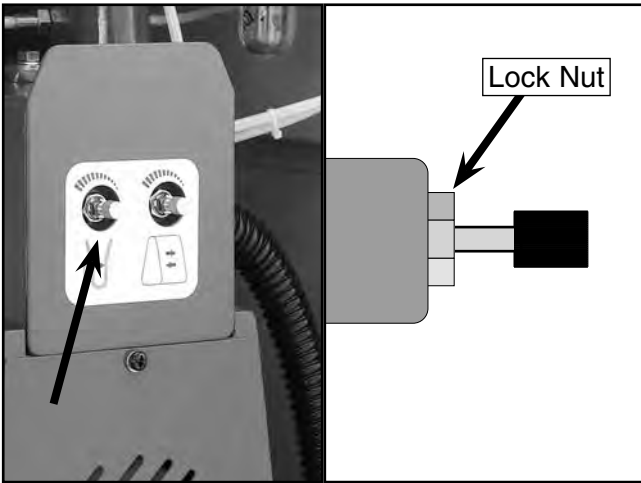

Figure 30. Airflow adjustment knob.

6. Restrict the airflow across the air fork gap with a scrap piece of wood. You should notice the roller pivot to the right. When the stick is removed, the roller should pivot back to the left.

7. Test the oscillation by running the sander. Make note of the time it takes for the belt to oscillate from left-to-right and from right-to-left.

When correctly timed, the oscillation should take a similar amount of time to oscillate.

- If the oscillation time to the **right** is 2 seconds, but the oscillation time to the **left** is longer, loosen the oscillation adjustment knob (**Figure 31**) and move it to the **left** until proper tracking is achieved. Tighten down the oscillation adjustment knob when satisfied.

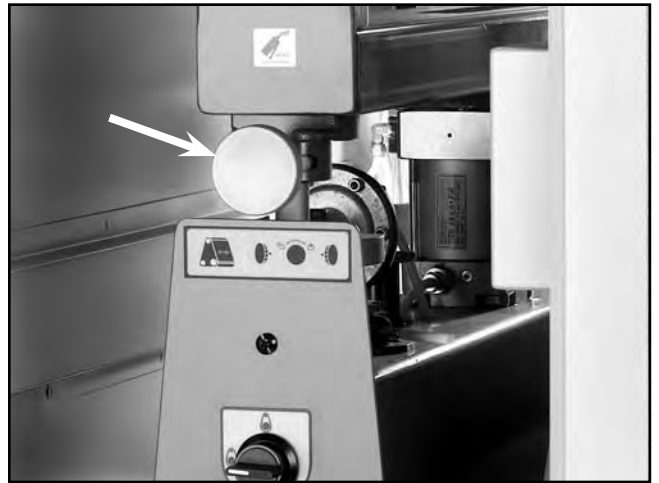

Figure 31. Oscillation adjustment knob.

- If the oscillation time to the **left** is 2 seconds, but the oscillation time to the **right** is longer, loosen the oscillation adjustment knob and move it to the **right** until proper tracking is achieved. Tighten down the oscillation adjustment knob when satisfied.

8. Continue to the next page to adjust the oscillation speed.



Oscillation Speed

The oscillation speed of the sanding belt is adjustable. Different oscillating speeds yield different sanding results. We recommend trying various speeds on a scrap piece of wood similar to the final workpiece.

To adjust the oscillation speed:

1. Loosen the lock nut on the speed control adjustment knob (**Figure 32**).

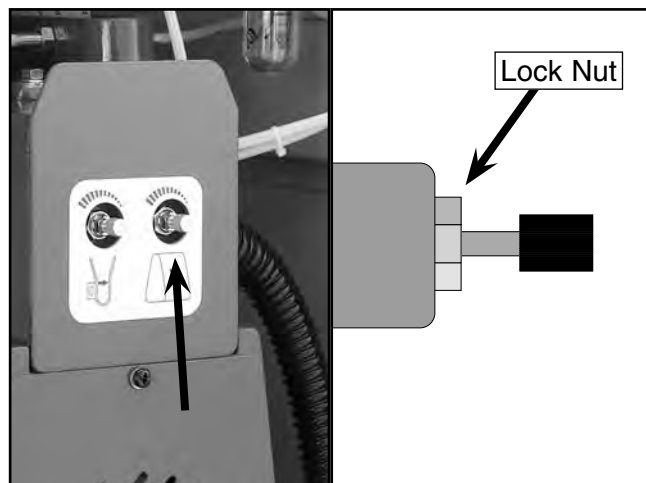

Figure 32. Speed control adjustment knob.

2. Turn the knob clockwise to decrease the oscillation speed and counterclockwise to increase it.
3. Tighten the lock nut loosened in **Step 1** to secure the knob.



Table Parallelism

NOTICE

The table has been adjusted at the factory and should require no further attention. However, we recommend verifying its parallelism with the sanding roller.

The corners of the table can be independently adjusted up or down. By disconnecting the chain and turning the pertinent table elevation screw sprocket, (**Figure 33**) table parallelism can be achieved.

Adjusting the table parallelism can be a very tedious task that takes a great amount of patience. DO NOT adjust the table unless you are having trouble sanding your workpiece to a uniform thickness.

If a table adjustment is needed, take precise notes on the positioning of the table elevation screws. This will allow the original setting to be re-established.

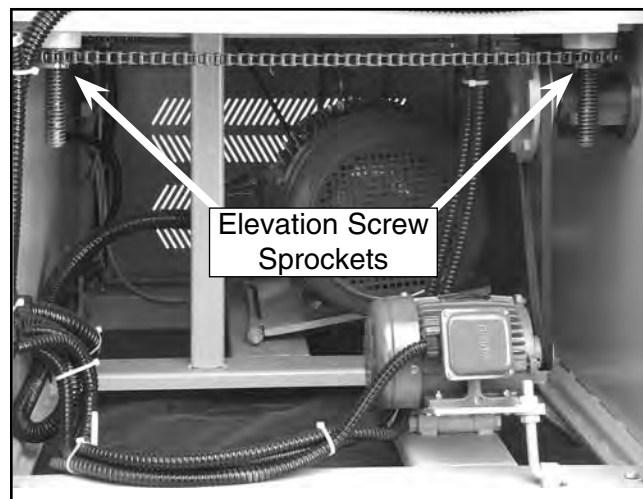

Figure 33. View of elevation screw sprockets.

To adjust the table parallelism:

1. Pass a 37" wide board through the sander until the **entire** surface of the board is making contact with the sanding belt.
2. Measure the thickness of the board at various points around the edge.
3. If there is a variation of thickness, the table can be adjusted accordingly.
4. **Disconnect the sander from the power source!**

—For minor adjustment, loosen the table mounting bolts shown in **Figure 34** and rotate the elevation screw flange.

—For major adjustment, mark the chain location on all sprockets, remove the chain from the sprocket to be adjusted, and turn the sprocket counterclockwise to raise the table. One quarter of a turn raises or lowers an elevation screw approximately 0.020"

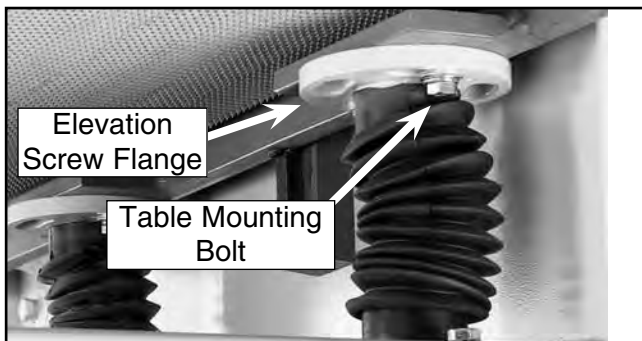

Figure 34. Table mounting bolts.

NOTICE

When adjusting the left front elevation screw, make the same adjustment to the left rear elevation screw. This ensures the height from the front to the back of the table remains unchanged. Do the same when adjusting the right elevation screws.

5. Reinstall the chain, tighten the bolts, and test the machine.



Pressure Rollers

To adjust the pressure rollers:

1. **Disconnect the sander from the power source!**
2. Plane (2) 36" long 2 x 4's to a uniform thicknesses. Place one board along the length of the feed belt on the right-hand side and place the other board on the left-hand side.
3. With the sanding belt tensioned (**Figure 35**), move the sanding rollers and manually raise the table until you just hear the sandpaper make contact with the surface of the wood. **DO NOT** continue to raise the table beyond that point.



Figure 35. Roller tension switch.

4. Connect the sander to the power source and make note of the reading on the digital display. Then manually lower the table 0.020" to 0.030". This is how much lower the infeed pressure roller should be set when compared to the sanding surface of the sanding roller.
5. **Disconnect the sander from the power source!**

- Loosen the roller lock nuts (**Figure 36**) on the infeed pressure roller. Turn the adjustment nuts (**Figure 36**) to lower the pressure roller until it just touches the board.

Note: DO NOT continue to lower the roller beyond that point.

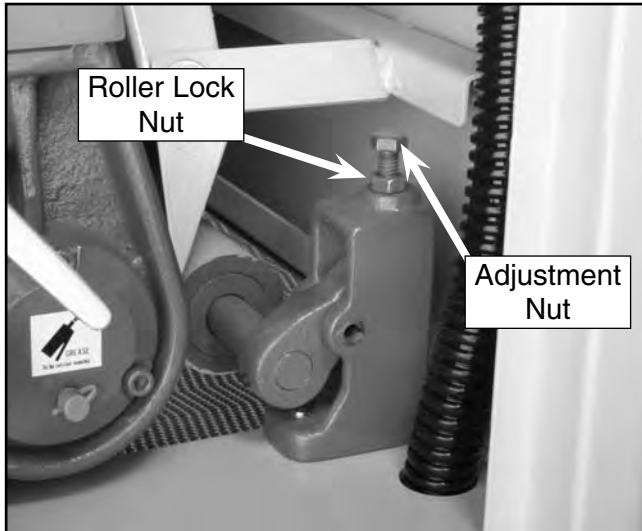

Figure 36. Pressure roller parts.

- Tighten the roller lock nuts and recheck your settings.
- Connect the sander to the power source and make note of the reading on the digital display. Then manually lower the table an additional 0.02" to 0.03". This is how much lower the outfeed pressure roller should be set when compared to the height of the infeed roller.
- Loosen the roller lock nuts on the outfeed pressure roller. Turn the adjustment bolts to lower the pressure roller until it just touches the board. **Note:** DO NOT continue to lower the roller beyond that point.
- Tighten the roller lock nuts and recheck your settings.

Note: Variables such as feed rate, depth of the cut, and the type of sanding belt can play a big part in determining the proper amount of downward pressure exerted by the rollers. Some experimentation may be necessary to achieve the desired results. However, under no circumstances should the pressure rollers be set even, or higher than, the sanding roller.



V-Belt Adjustment

To adjust either V-belt:

- Disconnect the sander from the power source!
- Loosen the lock nut (**Figures 37 & 38**).

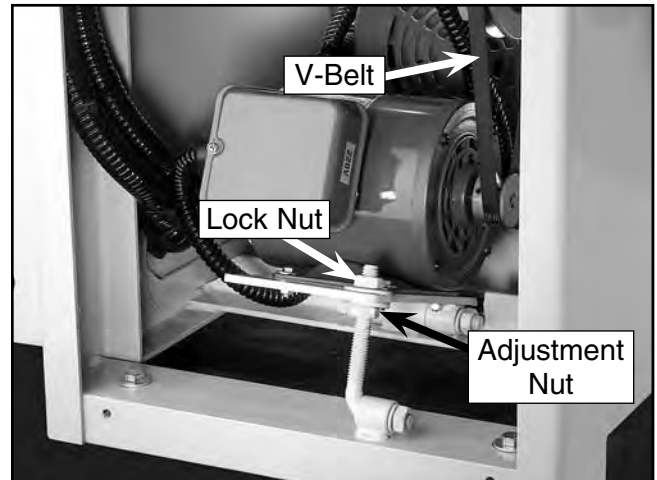

Figure 37. Table elevation V-belt.

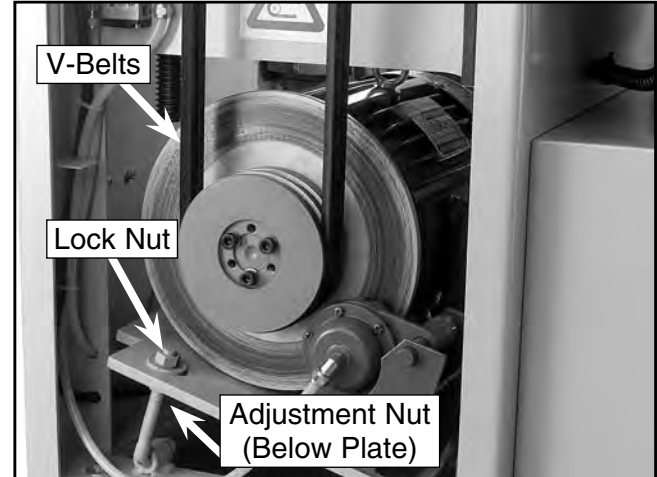

Figure 38. Sanding drum V-belts.

- Turn the adjustment nut up or down until the V-belt deflects 1" off of center when pushed with your finger.
- Retighten the lock nut.



Air System Diagram (G0446/G0539/G0571)

- | | |
|---|--|
| <ul style="list-style-type: none"> A. Shop Compressor B. Air Pressure Regulator C. Emergency Brake Solenoid D. Emergency Brake E. Air Distribution Manifold F. Airflow Adjustment Knob
(Oscillation Timing) G. Speed Control Adjustment Knob
(Oscillation Speed) H. Oscillation Controller Air Fork | <ul style="list-style-type: none"> I. Oscillation Timing Piston and Diaphragm Assy. J. Oscillation Speed Control Piston K. Belt Tension Control Piston L. Belt Tension Control Switch M. Emergency Stop Button Switch N. Emergency Stop Push Brake Switch O. Left Belt Limit Switch P. Right Belt Limit Switch Q. Belt Tension Limit Switch R. Emergency Brake Contactor |
|---|--|

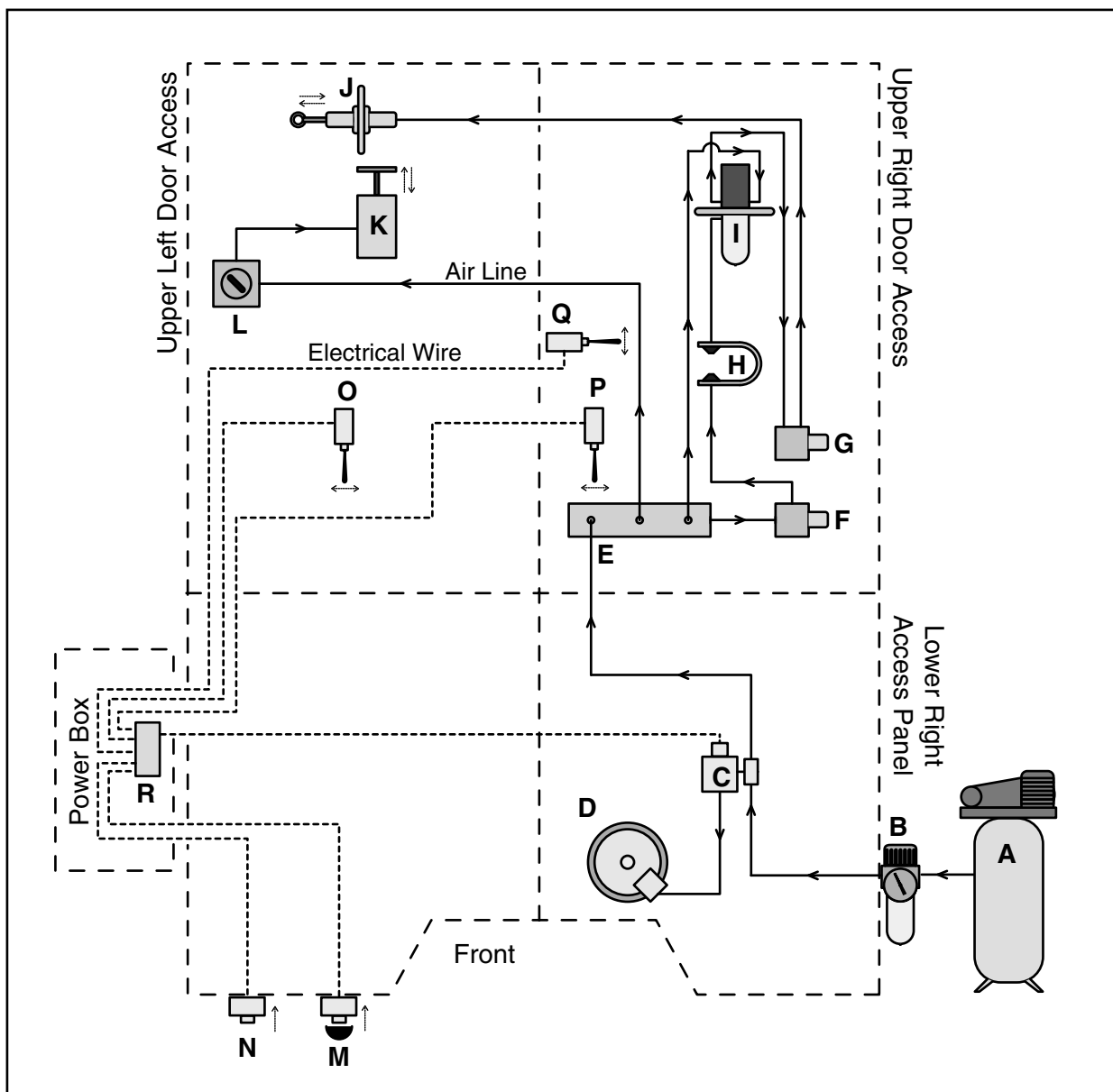

Wiring Box Electrical Diagram (G0446/G0539/G0571)

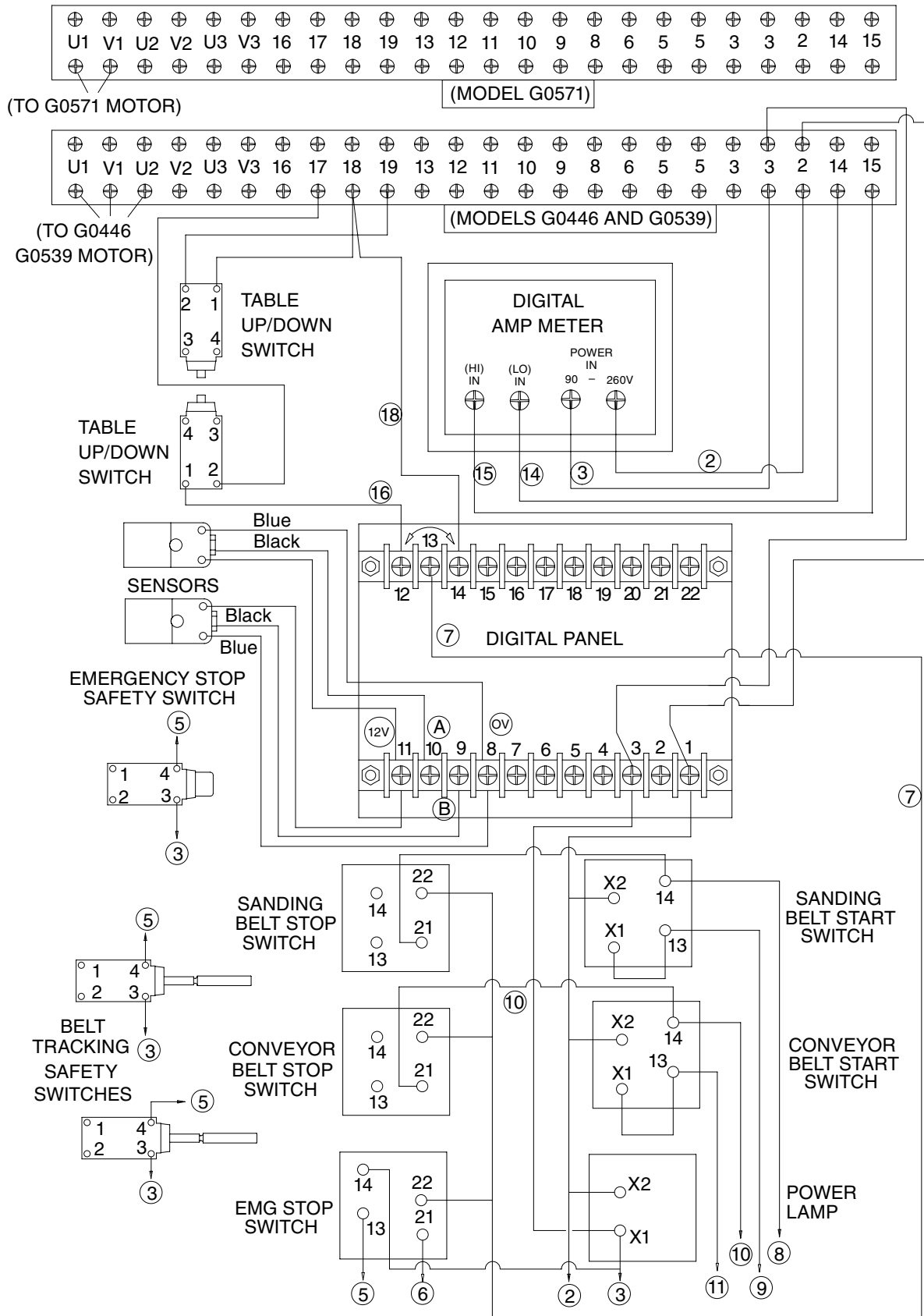

Control Panel Component Locations (G0446/G0539/G0571)

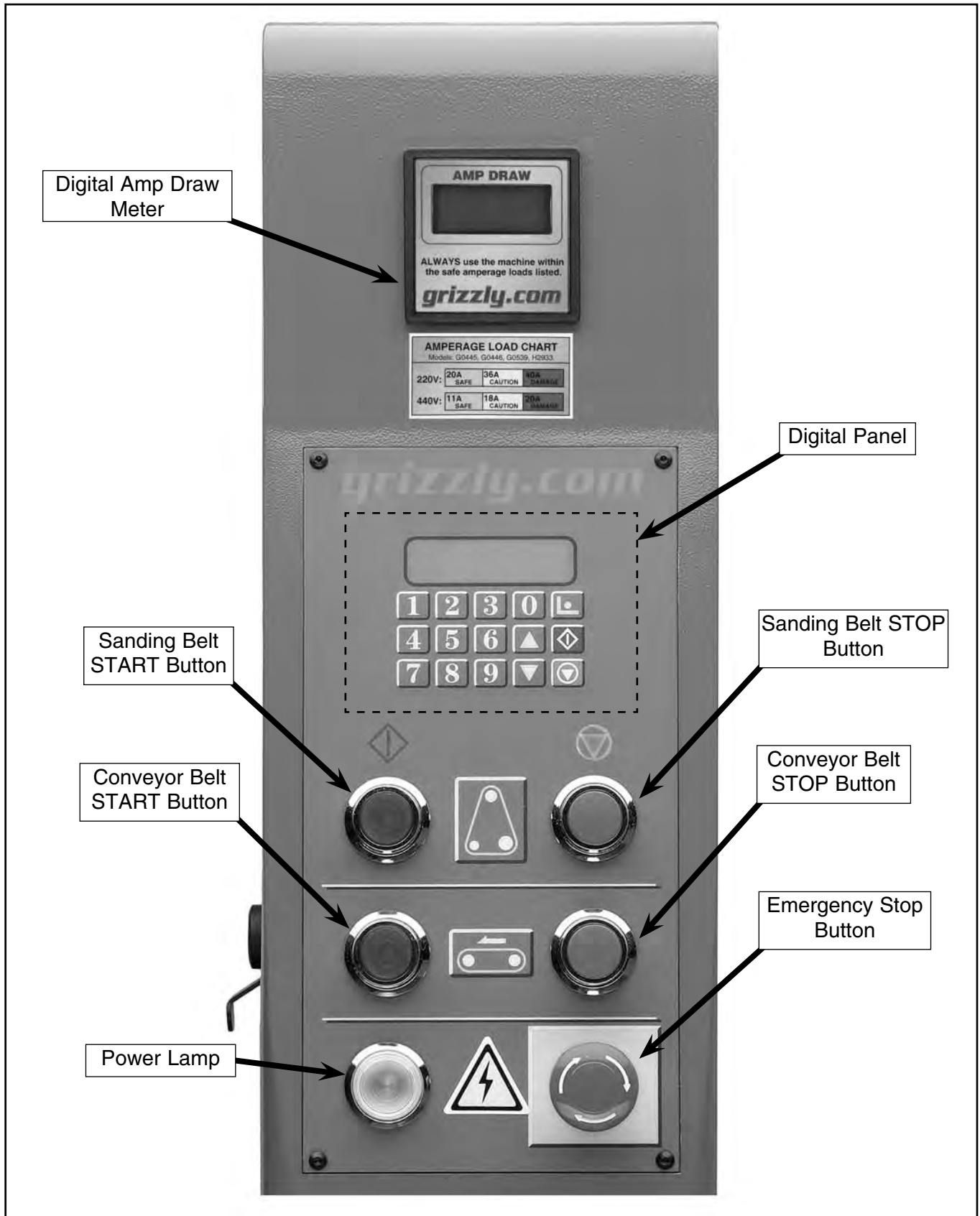

Wiring Box Electrical Diagram (G0446/G0539)

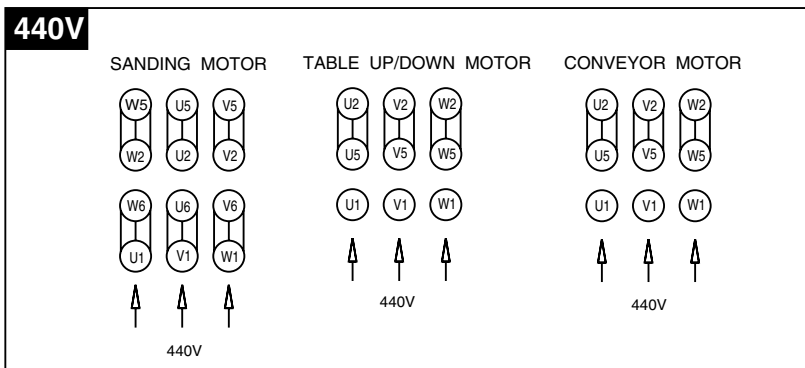
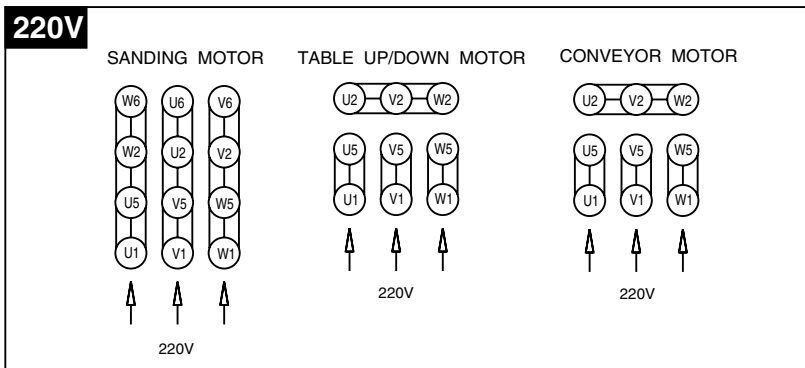
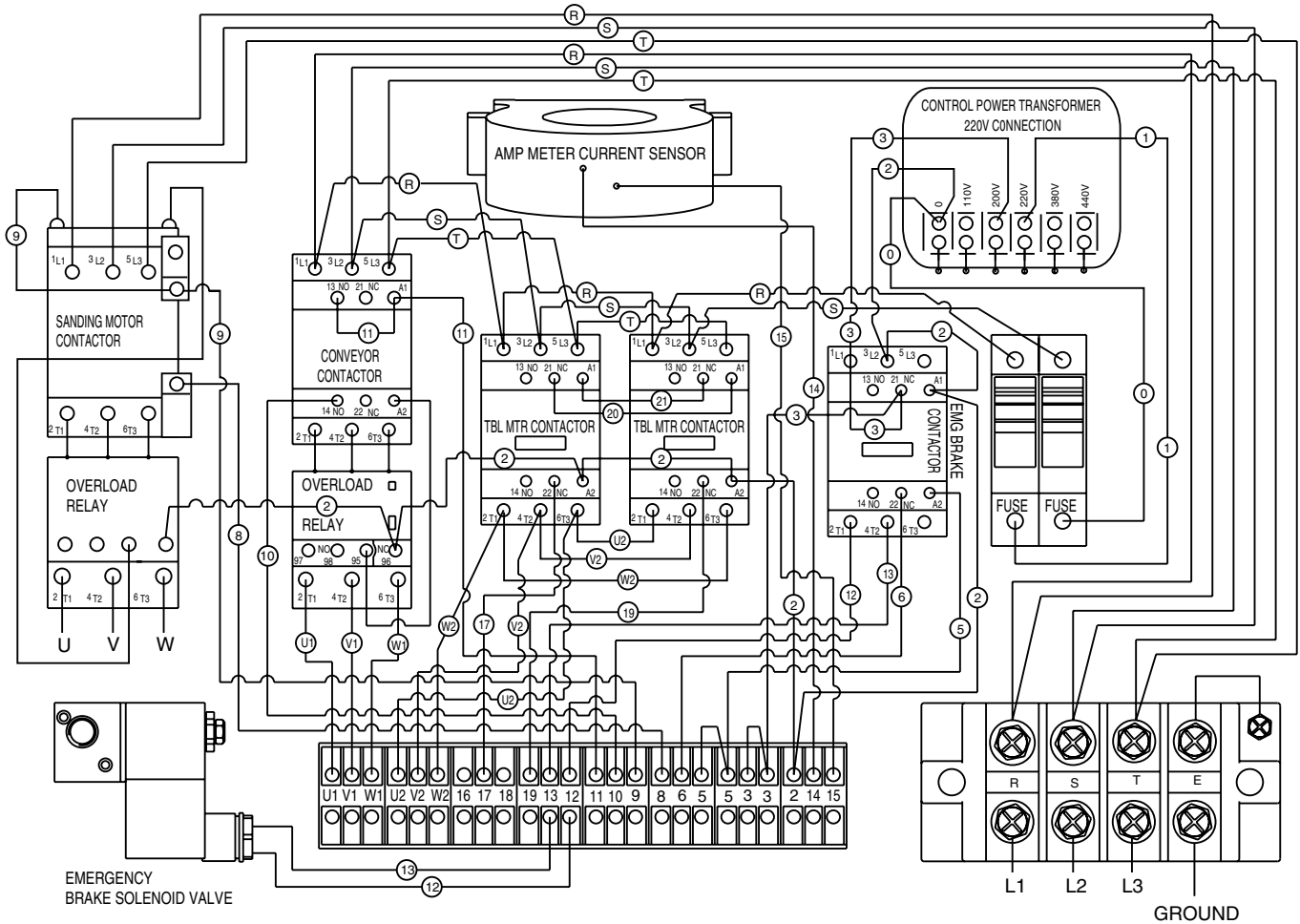

Wiring Box Components (G0446/G0539)

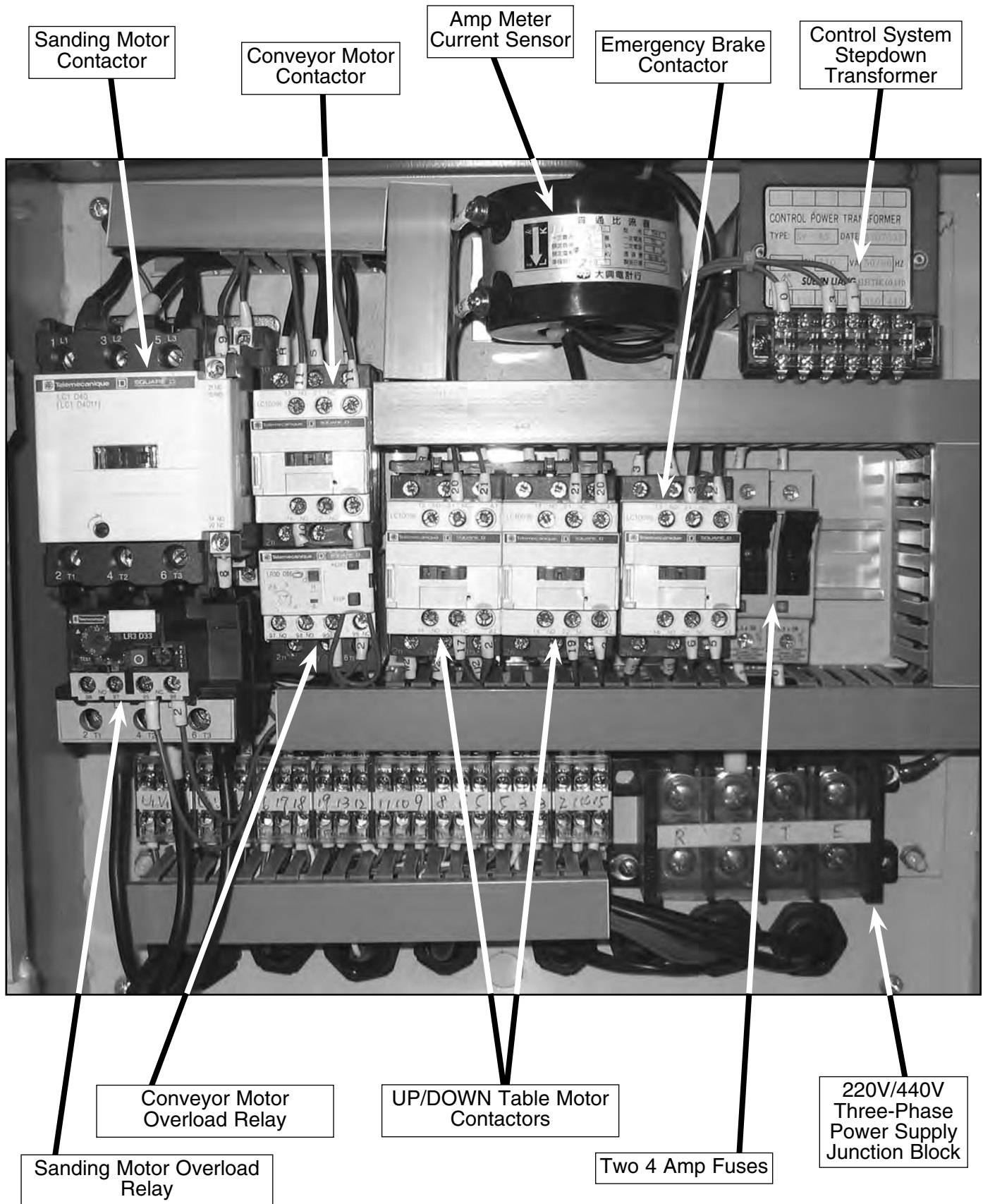

Wiring Box Electrical Diagram (G0571)

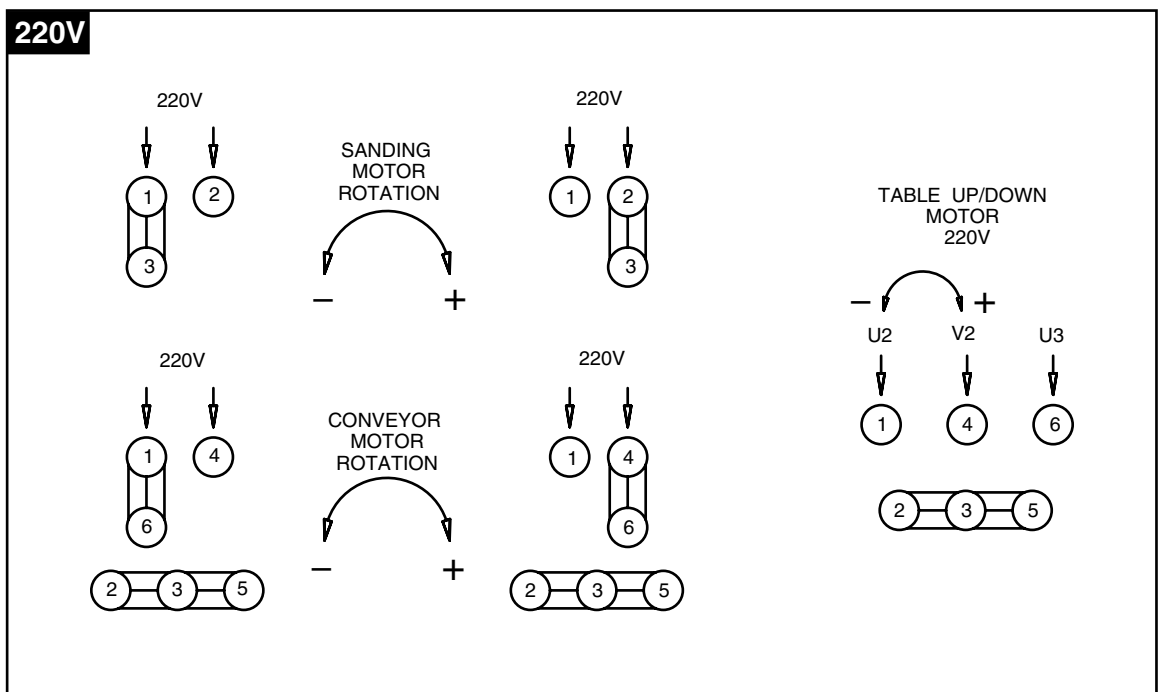
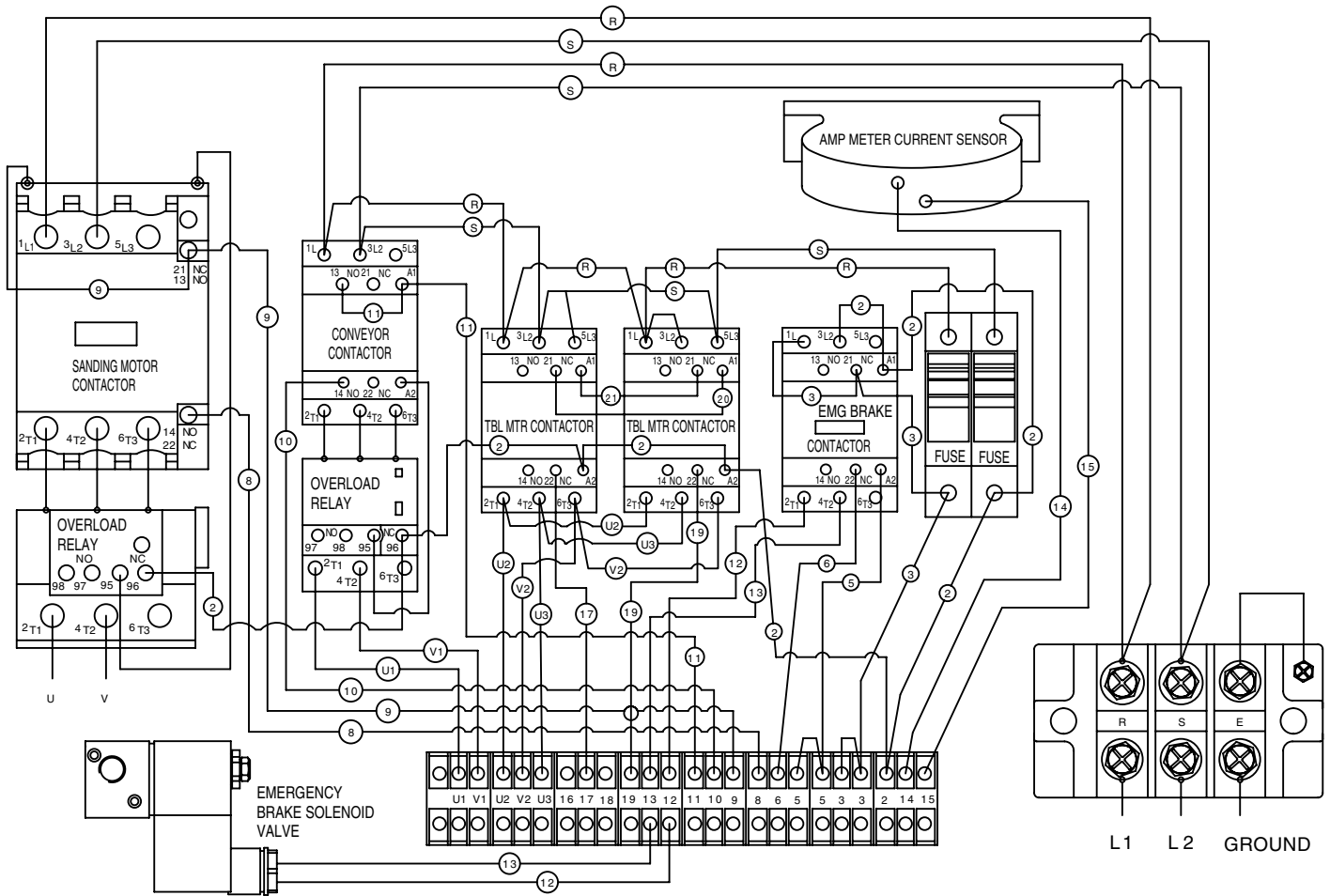

Wiring Box Components (G0571)

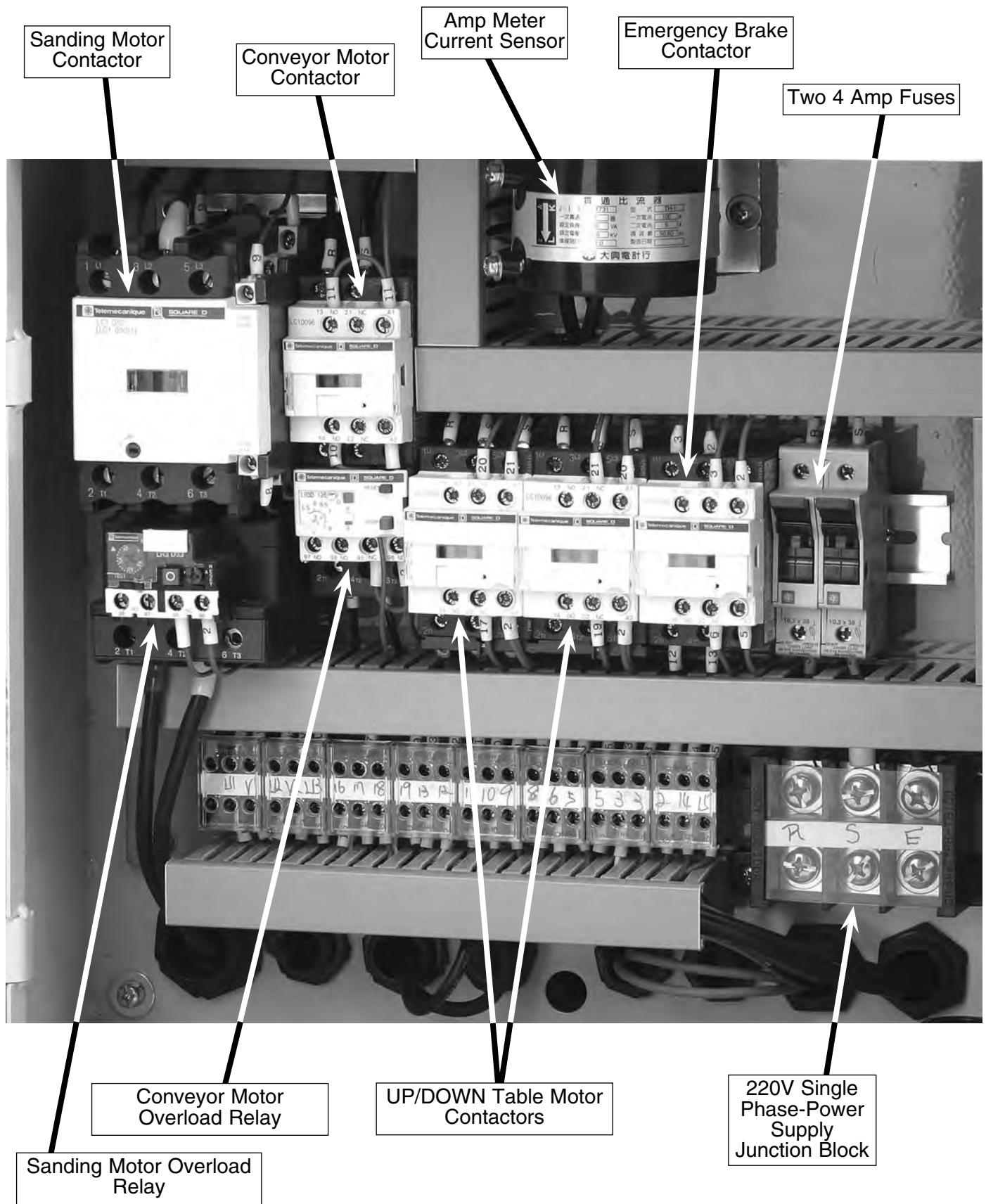

General Electrical Diagram (G0446/G0539)

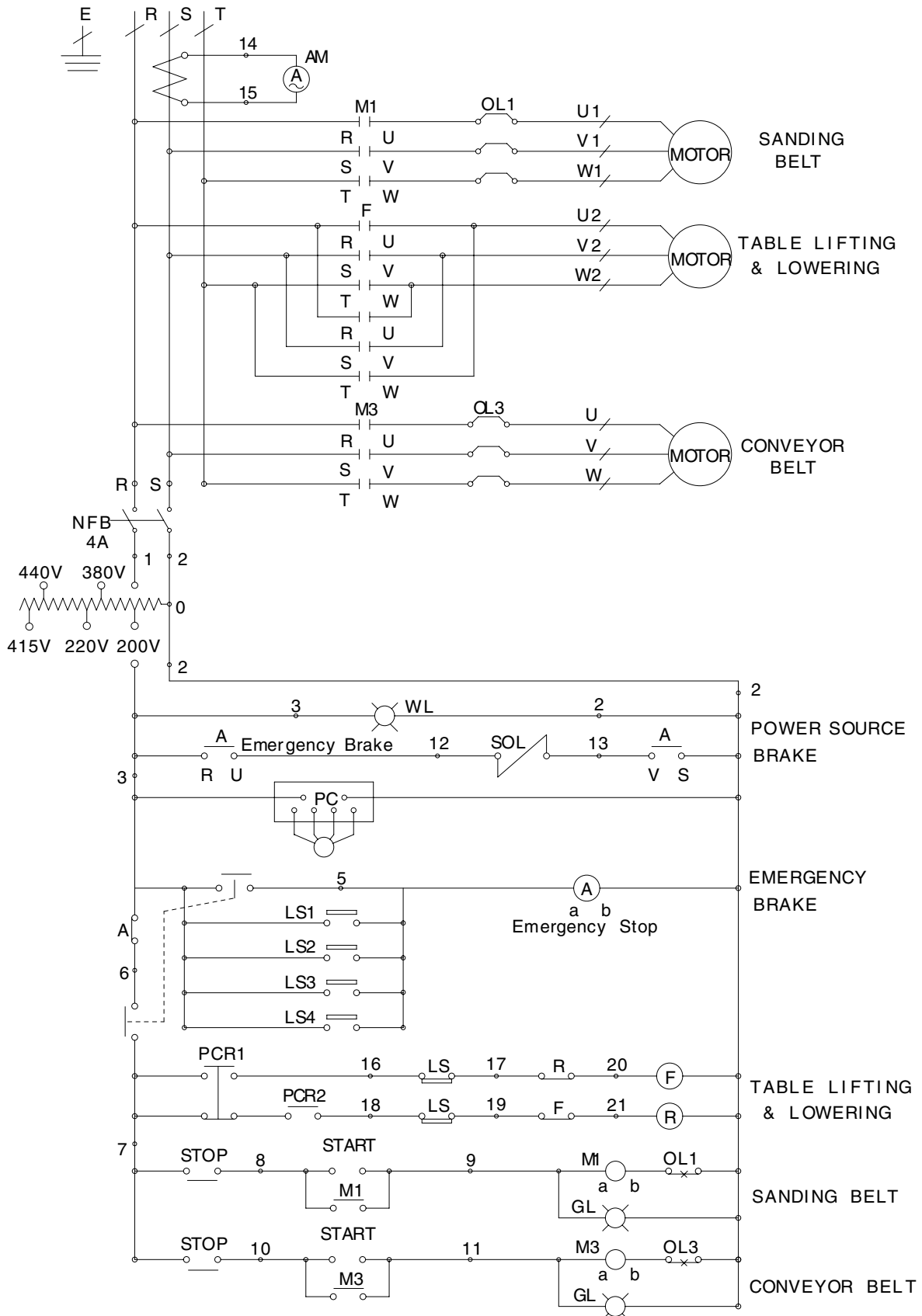

General Electrical Diagram (G0571)

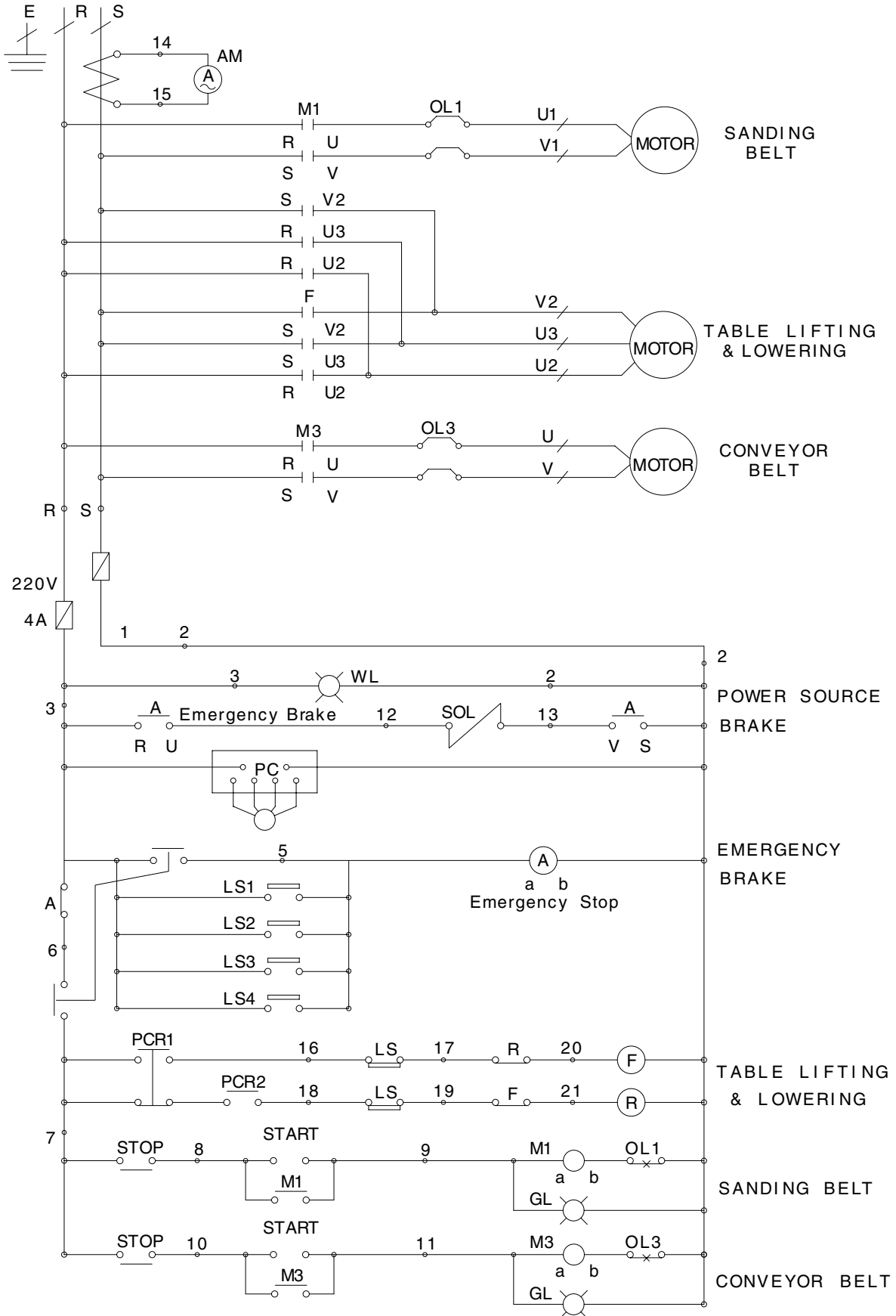

Main Electrical Panel and Controls Diagram

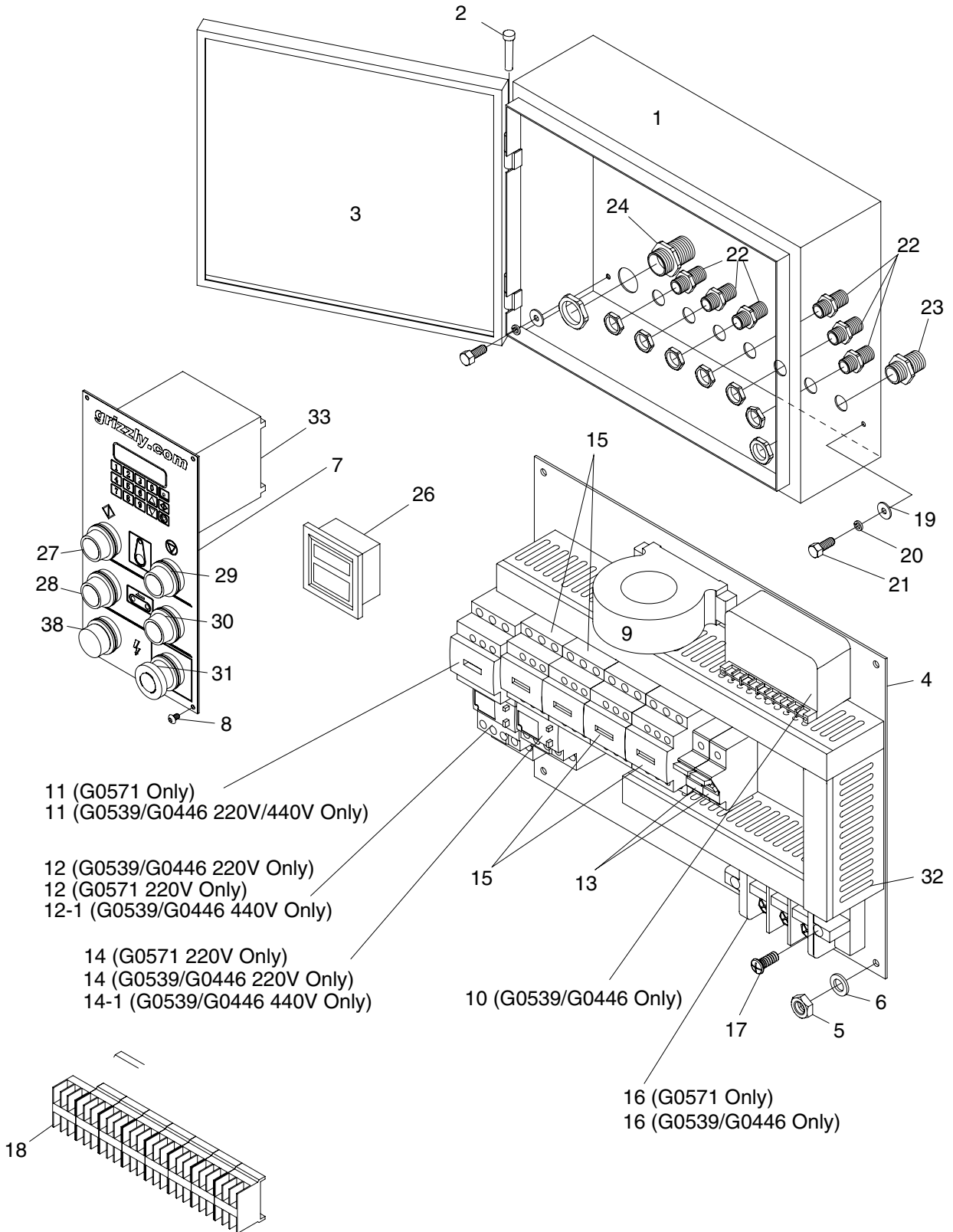

Parts List

REF	PART #	DESCRIPTION
1	P05398101	ELECTRICAL CONTROL BOX
2	P05398102	HINGE
3	P05398103	DOOR
4	P05398104	BASE PLATE
5	PN05	HEX NUT 1/4-20
6	PLW02	LOCK WASHER 1/4
7	P05398107	CONTROL PANEL
8	PS07M	PHLP HD SCR M4-.7 X 8
9	P0539009	CURRENT SENSOR
10	P0539010	TRANSFORMER 3PH (G0539/G0446)
11	P0571011	CONTR LC1-D50 (G0571)
11	P0539011	CONTR SWTCH LC1-D40 (G0539/G0446)
12	P0571012	RELAY LR3D-3359 (48-65A) (G0571)
12	P0539012	RELAY LR3D-3355 (30-40A) (G0539/G0446)
13	P0539013	FUSE 4A
14	P05718114	OVERLD RELAY LR3D-126 (G0571)
14	P05398114	OVERLOAD RELAY LR3D-086 (G0539/G0446)

REF	PART #	DESCRIPTION
15	P05398115	CONTACTOR LC1-D096M7
16	P0571016	BLOCK (G0571)
16	P05398116	BLOCK (G0539/G0446)
17	PS51M	PHLP HD SCR M4-.7 X 30
18	P05398118	TERMINAL PLATE
19	PW06	FLAT WASHER 1/4
20	PLW02	LOCK WASHER 1/4
21	PS04	PHLP HD SCR 1/4-20 X 1/2
22	P05398122	PU CONNECTOR 1/2
23	P05398123	PU CONNECTOR 3/4
24	P05398124	CABLE CONNECTOR 1"
26	P05398126A	DIGITAL AMP METER
27	P05398128-1	START SWITCH
28	P05398128-2	START SWITCH
29	P05398129-1	STOP SWITCH
30	P05398129-2	STOP SWITCH
31	P05398131	EMERGENCY STOP SWITCH
32	P05398132	WIRE COLUMN
33	P05398133	COMPUTER
38	P05398130	POWER INDICATION LIGHT

440V CONVERSION PARTS (G0446/G0539)

REF	PART #	DESCRIPTION
12-1	P0539012-1	RELAY LR3D-3322 (17-25A)
14-1	P0539014-1	RELAY LR3D-076 (1.6-2.5A)

Sanding Motor Diagram

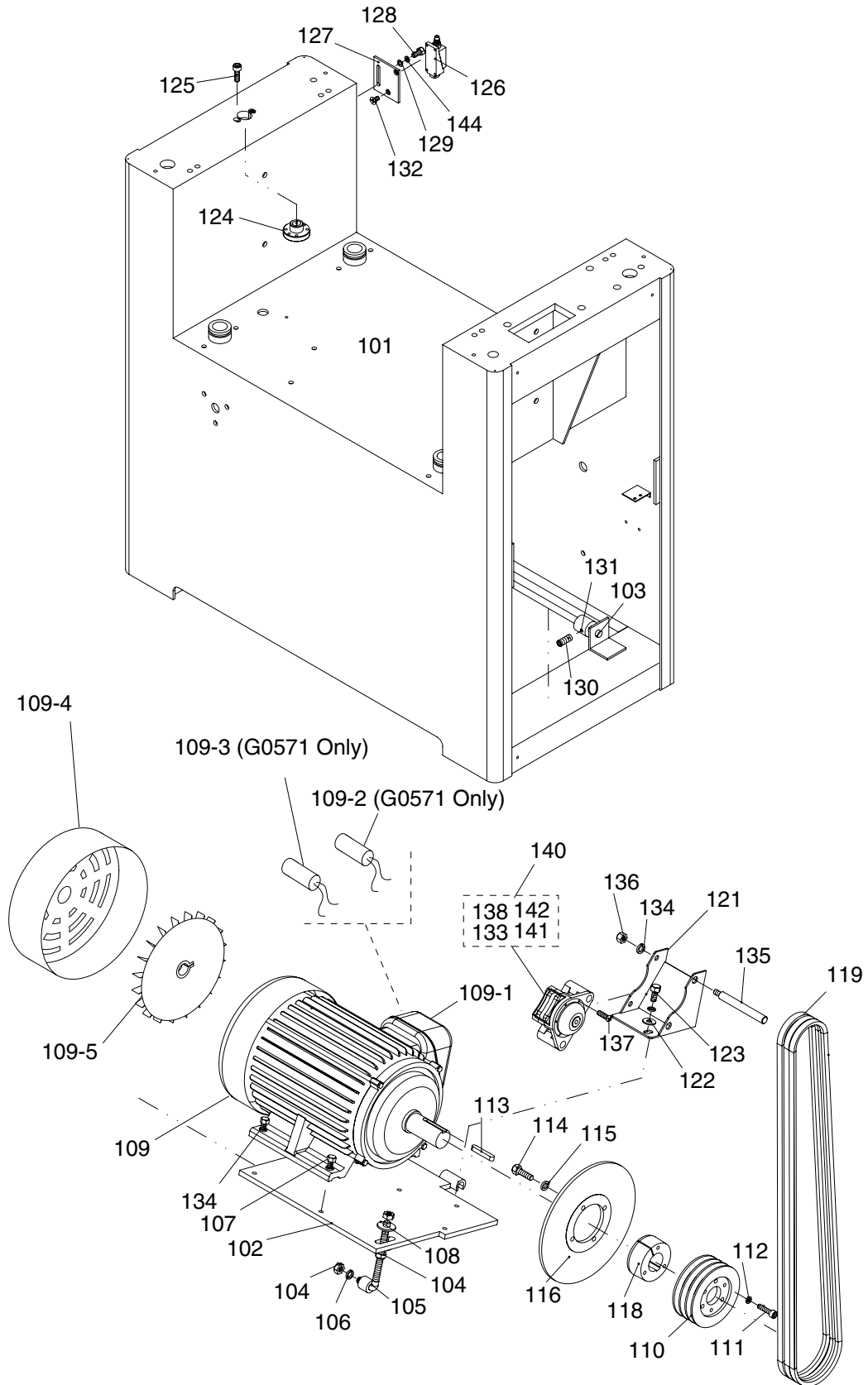

Parts List

REF	PART #	DESCRIPTION
101	P0539101	MACHINE FRAME
102	P0539102	MOTOR BASE
103	P0539103	MOTOR BASE HINGE
104	PN06	HEX NUT 1/2-12
105	P0539105	BASE ADJUSTMENT ROD
106	PLW07	LOCK WASHER 1/2
107	PB24	HEX BOLT 3/8-16 X 1 1/4
108	PW01	FLAT WASHER 1/2
109	P0571109	MOTOR 10HP 1PH (G0571)
109	P0539143	MOTOR 15HP 3PH (G0539 & G0446)
109-1	P0571109-1	WIRING BOX (G0571)
109-1	P0539143-1	WIRING BOX (G0539 & G0446)
109-2	P0571109-2	S. CAPACITOR (G0571)
109-3	P0571109-3	R. CAPACITOR (G0571)
109-4	P0571109-4	FAN COVER (G0571)
109-4	P0539143-1	FAN COVER (G0539 & G0446)
109-5	P0571109-5	FAN (G0571)
109-5	P0539143-2	FAN (G0539 & G0446)
110	P0539110	PULLEY
111	PSB08	CAP SCREW 5/16-18 x 1 1/2
112	PLW01	LOCK WASHER 5/16
113	P0539113	MOTOR KEY
114	PB03	HEX BOLT 5/16-18 X 1
115	PLW01	LOCK WASHER 5/16
116	P0539116	BRAKE

REF	PART #	DESCRIPTION
118	P0539118	PULLEY BUSHING
119	PVA71	V-BELT A-71 4L710
121	P0539121	BRAKE BRACKET
122	PW02	FLAT WASHER 3/8
123	PB21	HEX BOLT 3/8-16 X 3/4
124	P0539124	FLAT HEAD NUT
125	PSB05	CAP SCREW 1/4-20 X 3/4
126	P0539126	LIMIT SWITCH
127	P0539127	LIMIT SWITCH PLATE
128	PS04	PHLP HD SCR 1/4-20 X 1/2
129	PW06	FLAT WASHER 1/4
130	PSB07	CAP SCREW 5/16-18 X 3/4
131	P0539131	COVER
132	PFH12M	FLAT HD SCR M6-1 X 25
133	P0539133	BRAKE ARBOR
134	PLW04	LOCK WASHER 3/8
135	P0539135	BRAKE PIN
136	PN08	HEX NUT 3/8-16
137	PSB10M	CAP SCREW M5-.8 X 15
138	P0539138	BRAKE LINING
140	P0539140	COMPLETE BRAKE ASSY.
141	P0539141	BRAKE SPRING
142	P0539142	BRAKE INSIDE PIECE
144	PLW02	LOCK WASHER 1/4

Table Lift System Diagram

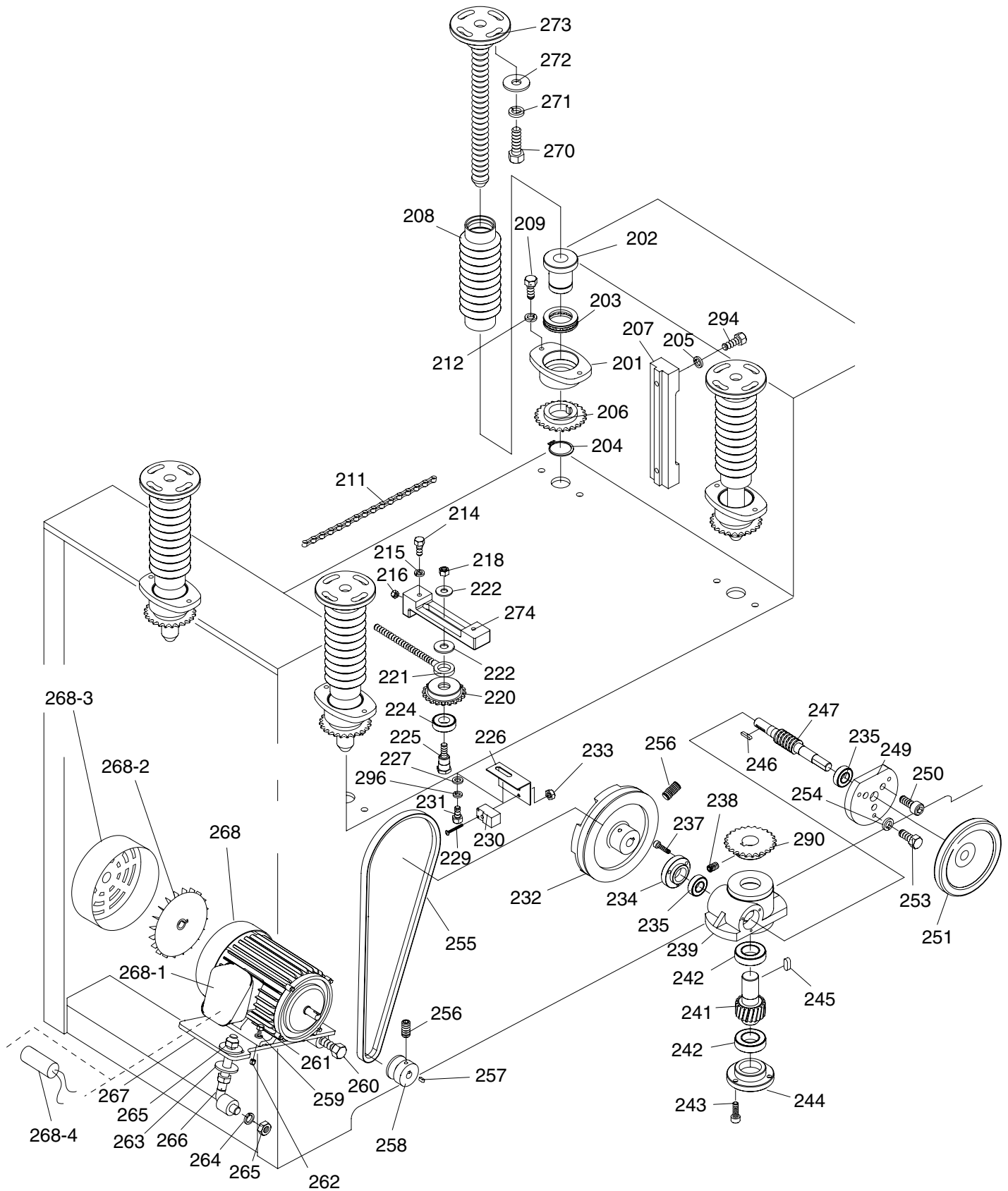

Parts List

REF	PART #	DESCRIPTION
201	P0539201	HEX NUT HOUSING
202	P0539202	COLUMN NUT
203	P51107	THRUST BEARING 51107
204	PR12M	EXT RETAINING RING 35MM
205	PLW04	LOCK WASHER 3/8
206	P0539206	SPROCKET WHEEL
207	P0539207	ELEVATION SLIDE
208	P0539208	DUST BOOT
209	PB07	HEX BOLT 5/16-18 X 3/4
211	P0539211	CHAIN
212	PLW01	LOCK WASHER 5/16
214	PB07	HEX BOLT 5/16-18 X 3/4
215	PLW01	LOCK WASHER 5/16
216	PN02	HEX NUT 5/16-18
218	PN08	HEX NUT 3/8-16
220	P0539220	SPROCKET WHEEL
221	P0539221	WHEEL ROD
222	PW02	FLAT WASHER 3/8
224	P6003	BALL BEARING 6003ZZ
225	P0539225	SPROCKET SHAFT
226	P0539226	SWITCH PLATE
227	PW06	FLAT WASHER 1/4
229	PS97M	PHLP HD SCR M3-.5 X 35
230	P0539230	PROXIMITY SWITCH
231	PB193	HEX BOLT 1/2-12 X 2 1/2
232	P0539232	PULLEY
233	PN07M	HEX NUT M3-.5
234	P0539234	BEARING CAP
235	P6002	BALL BEARING 6002Z
237	PSB31	CAP SCREW 10-24 X 5/8
238	PSS07	SET SCREW 1/4-20 X 1/2
239	P0539239	ELEVATION GEAR BOX
241	P0539241	WORM GEAR
242	P6005	BALL BEARING 6005Z
243	PSB05	CAP SCREW 1/4-20 X 3/4
244	P0539244	BEARING CAP
245	PK14	KEY 5/16 X 5/16 X 3/4
246	PK48M	KEY 4 X 4 X 20

REF	PART #	DESCRIPTION
247	P0539247	WORM GEAR
249	P0539249	BEARING CAP
250	PSB01	CAP SCREW 1/4-20 X 5/8
251	P0539251	HAND WHEEL
253	PB07	HEX BOLT 5/16-18 X 3/4
254	PLW01	LOCK WASHER 5/16
255	PVA37	V-BELT A-37 4L370 (G0539/G0446)
255	PVA36	V-BELT A-36 4L360 (G0571)
256	PSS07	SET SCREW 1/4-20 X 1/2
257	PK37M	KEY 4 X 4 X 16
258	P0571258	PULLEY (G0571)
258	P0539258	PULLEY (G0539/G0446)
259	PLW02	LOCK WASHER 1/4
260	PB89	HEX BOLT 1/2-12 X 4 1/2
261	PB31	HEX BOLT 1/4-20 X 1
262	PN05	HEX NUT 1/4-20
263	PW01	FLAT WASHER 1/2
264	PLW07	LOCK WASHER 1/2
265	PN06	HEX NUT 1/2-12
266	P0539266	ADJUSTMENT ROD
267	P0539267	MOTOR BASE
268	P0539268	MOTOR 1/4HP 3PH (G0539/G0446)
268	P0571268	MOTOR 1/3HP 1PH (G0571)
268-1	P0539268-1	ELECTRICAL BOX (G0539/G0446)
268-1	P0571268-1	ELECTRICAL BOX (G0571)
268-2	P0539268-2	FAN (G0539/G0446)
268-2	P0571268-2	FAN (G0571)
268-3	P0539268-3	FAN COVER (G0539/G0446)
268-3	P0571268-3	MOTOR FAN COVER (G0571)
268-4	P0571268-4	CAPACITOR (G0571)
270	PB12	HEX BOLT 5/16-18 X 1 1/4
271	PLW01	LOCK WASHER 5/16
272	PW07	FLAT WASHER 5/16
273	P0539273	ELEVATION SCREW
274	P0539274	WHEEL ADJUSTER
290	P0539290	SPROCKET WHEEL
294	PB18	HEX BOLT 3/8-16 X 1
296	PLW02	LOCK WASHER 1/4

Conveyor System Diagram

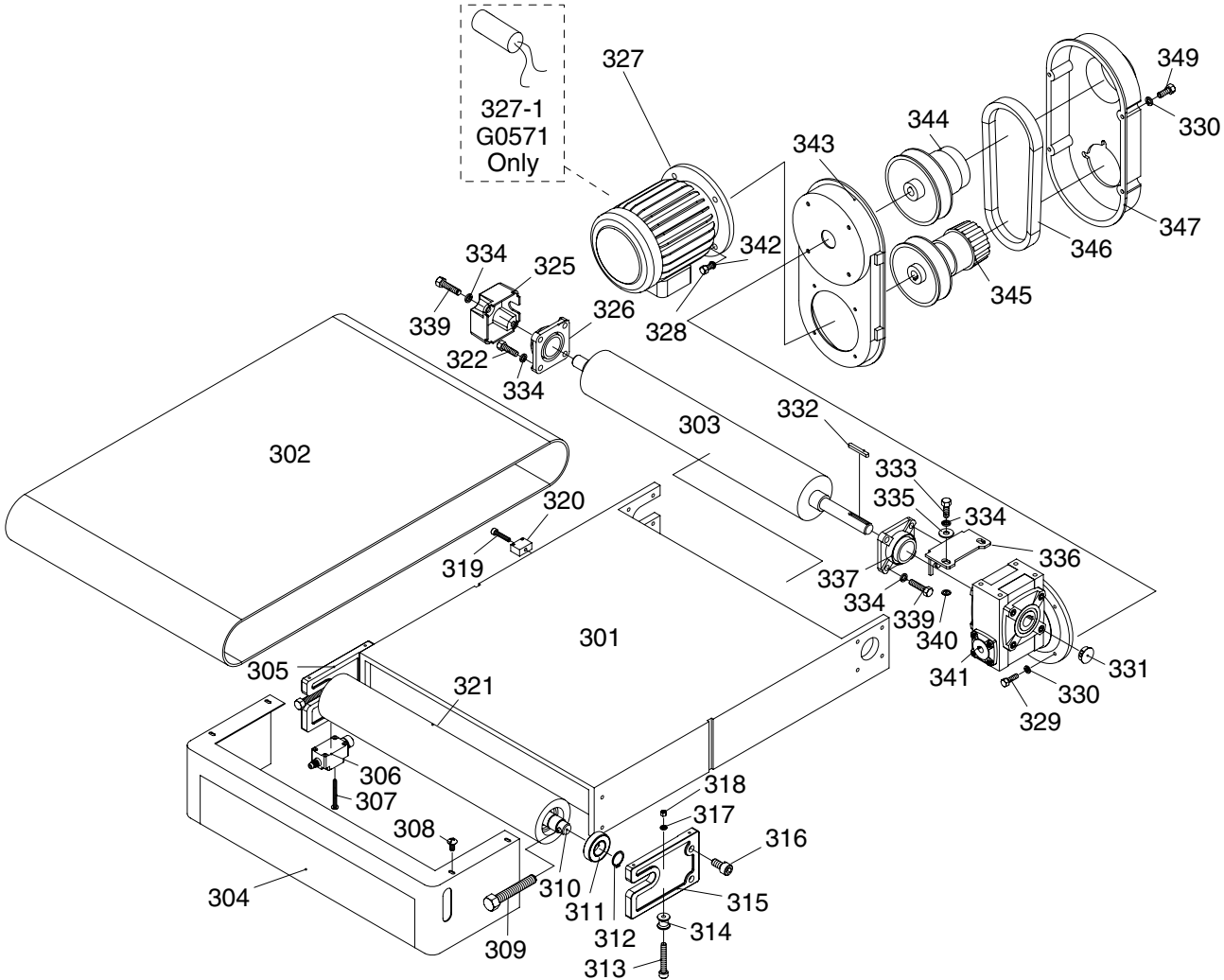

Parts List

REF	PART #	DESCRIPTION
301	P0539301	TABLE
302	P0539302	CONVEYOR BELT
303	P0539303	OUTFEED ROLLER
304	P0539304	FRONT BRAKE COVER
305	P0539305	INFEED ROLLER BRACKET
306	P0539306	LIMIT SWITCH
307	PS10	PHLP HD SCR 10-24 x 1 1/2
308	PS04	PHLP HD SCR 1/4-20 X 1/2
309	PB95	HEX BOLT 1/2-12 X 3
310	P0539310	INFEED ROLLER SHAFT
311	P2606	BALL BEARING 6206-2RS
312	PR15M	EXT RETAINING RING 30MM
313	PSB70	CAP SCREW 5/16-18 X 2
314	P0539314	POSITIONING WHEEL
315	P0539315	INFEED ROLLER BRACKET
316	PSB16	CAP SCREW 3/8-16 X 3/4
317	PLW01	LOCK WASHER 5/16
318	PN02	HEX NUT 5/16-18
319	PSB62	CAP SCREW 1/4-20 X 1 1/2
320	P0539320	ELEVATION LIMITER
321	P0539321	INFEED ROLLER
322	PB24	HEX BOLT 3/8-16 X 1 1/4
325	P0539325	BEARING CAP
326	P0539326	BEARING UCF205

REF	PART #	DESCRIPTION
327	P0539327	MOTOR 1HP 1PH (G0539/G0446)
327	P0571327	MOTOR 1HP 1PH (G0571)
327-1	P0571327-1	CAPACITOR (G0571)
328	PB32M	HEX BOLT M10-1.5 x 25
329	PB07M	HEX BOLT M8-1.25 X 25
330	PLW04M	LOCK WASHER 8MM
331	P0539331	PLUG
332	PK66M	KEY 7 X 7 X 55
333	PB18	HEX BOLT 3/8-16 X 1
334	PLW04	LOCK WASHER 3/8
335	PW02	FLAT WASHER 3/8
336	P0539336	GEARBOX PLATE
337	P0539326	BEARING UCF205
339	PB16	HEX BOLT 3/8-16 X 1 1/2
340	P0539340	CUSHION
341	P0539341	REDUCER
342	PLW06M	LOCK WASHER 10MM
343	P0539343	SPEED UNIT BASE PLATE
344	P0539344	DRIVEN PULLEY
345	P0539345	DRIVING PULLEY
346	P0539346	TIMING BELT
347	P0539347	SPEED UNIT COVER
349	P0539349	SPECIAL SCR M8-1.25 X 20

Parts List

REF	PART #	DESCRIPTION
401	P0539401	UPPER ROLLER BRACKET
402	P0539402	UPPER ROLLER
403	P0539403	UPPER ROLLER BRACKET
404	P0539404	BEARING UCC205
405	P0539405	SET SCREW M6-1 X 6
406	P0539406	FILTER
408	PSB16	CAP SCREW 3/8-16 X 3/4
409	PLW04	LOCK WASHER 3/8
410	P0539410	THROTTLE VALVE
411	P0539411	THROTTLE VALVE BASE
412	PSB33	CAP SCREW 10-24 x 3/4
413	PS52M	PHLP HD SCR M4-.7 X 20
414	P0539414	ALUMINUM DISC
415	P0539415	ALUMINUM PLATE
416	P0539416	PLATE
417	PN07	HEX NUT 10-24
418	P0539418	OIL CAP CONNECTOR
419	P0539419	SHAFT OF OIL CAP
420	P0539420	OIL CAP
421	PS04	PHLP HD SCR 1/4-20 X 1/2
422	P0539422	FRAME SEAL, (R) (G0539/G0446)
422	P0446422	FRAME SEAL, (R) (G0446)
423	PLW07	LOCK WASHER 1/2
424	PB53	HEX BOLT 1/2-12 X 1
425	PN11	HEX NUT 3/8-24
426	P0539426	AIR NOZZLE (FEMALE)
427	P0539427	AIR CYLINDER BRACKET
428	P0539428	AIR RECEIVER (MALE)
431	P0539431	LIMIT SWITCH HOLDER
432	P0539432	LIMIT SWITCH TUBE
433	P0539433	LIMIT SWITCH W/CERAMIC TIP
434	P0446434	SQUARE FRAME (G0446)
434	P0539434	SQUARE FRAME (G0539/G0446)
435	P0539435	HOLDER (L TYPE)
436	P0539436	LIMIT SWITCH

REF	PART #	DESCRIPTION
437	P0539437	PLASTIC LIMIT SWITCH ROD
441	P0539441	AIR CYLINDER
442	PSB07	CAP SCREW 5/16-18 X 3/4
443	P0539443	BASE
445	P0539445	CAP SCREW 5/16-18 x 1 1/2
447	PN07	HEX NUT 10-24
448	PR05M	EXT RETAINING RING 15MM
449	PN02M	HEX NUT M10-1.5
450	P0539450	UNIVERSAL JOINT FORK
451	P0539451	LOCKING CLEVIS
452	PW01	FLAT WASHER 1/2
453	PSB79	CAP SCREW 1/2-12 X 3 1/2
455	P0539455	FRAME
456	P0539456	TRIMMING SCREW
457	P0539457	ECCENTRIC ROD
458	P0539458	ECCENTRIC
463	P0446463	FRAME SEAL, (L) (G0446)
463	P0539463	FRAME SEAL, (L) (G0539 & G0571)
464	PB18	HEX BOLT 3/8-16 X 1
465	PLW04	LOCK WASHER 3/8
466	P05396128	POWER OFF PLATE
467	PB07	HEX BOLT 5/16-18 X 3/4
468	PLW01	LOCK WASHER 5/16
469	PW07	FLAT WASHER 5/16
498	PN06	HEX NUT 1/2-12
499	P0539499	DIAPHRAM ASSY
499-1	P0539499-1	PUSHROD COVER
499-2	P0539499-2	COMPRESSION SPRING
499-3	P0539499-3	PUSHROD
499-4	P0539499-4	PLATE
499-5	P0539499-5	SPECIAL SCREW
499-6	P0539499-6	DIAPHRAM
499-7	P0539499-7	REAR HOUSING
499-8	PSB33	CAP SCREW 10-24 x 3/4

Belt Oscillation System Diagram

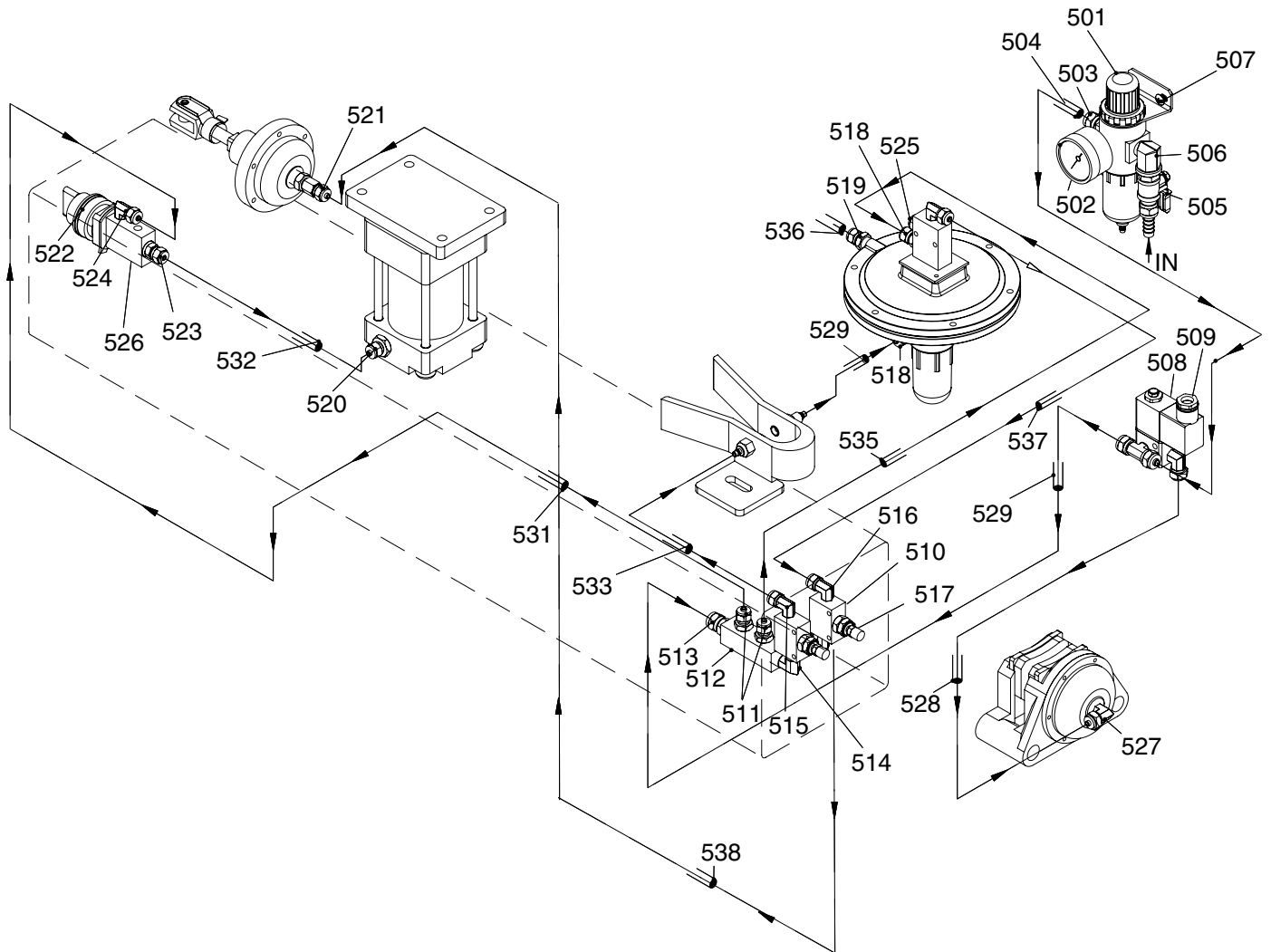

Parts List

REF	PART #	DESCRIPTION
501	P0539501	PRESSURE REGULATOR
502	P0539502	PSI GAUGE
503	P0539503	BRONZE CONNECTOR
504	P0539504	FLEXIBLE HOSE
505	P0539505	AIR SWITCH
506	P0539506	ELBOW
507	PS22	PHLP HD SCR 10-24 x 5/8
508	P0539508	SOLENOID VALVE
509	P0539509	SOLENOID VALVE
510	P0539510	THROTTLE VALVE
511	P0539511	CONNECTOR
512	P0539512	CONNECTOR
513	P0539513	CONNECTOR
514	P0539514	BRONZE ELBOW
515	P0539515	CONNECTOR
516	P0539516	CONNECTOR
517	P0539517	NEEDLE VALVE
518	P0539518	PLASTIC CONNECTOR

REF	PART #	DESCRIPTION
519	P0539519	BRONZE CONNECTOR
520	P0539520	CONNECTOR
521	P0539521	CONNECTOR
522	P0539522	AIR SWITCH 1/8
523	P0539523	CONNECTOR
524	P0539524	CONNECTOR
525	P0539525	BUFFER (BRONZE)
527	P0539527	PLASTIC CONNECTOR
528	P0539528	FLEXIBLE HOSE
529	P0539529	FLEXIBLE HOSE
531	P0539531	FLEXIBLE HOSE
532	P0539532	FLEXIBLE HOSE
533	P0539533	FLEXIBLE HOSE
535	P0539535	FLEXIBLE HOSE
536	P0539536	FLEXIBLE HOSE
537	P0539537	FLEXIBLE HOSE
538	P0539538	FLEXIBLE HOSE

Feed, Drum, and Pressure Roller Diagram

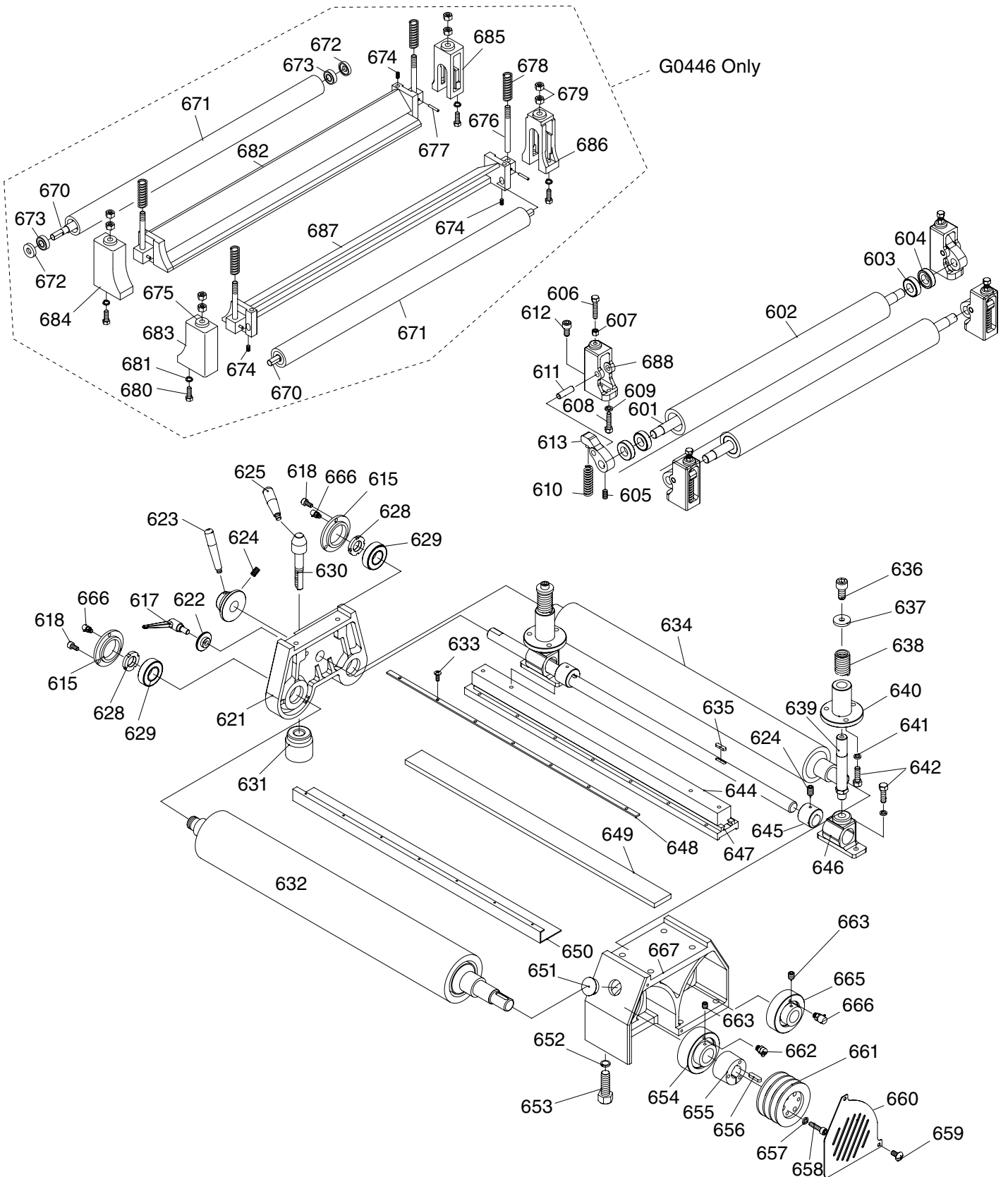

Parts List

REF	PART #	DESCRIPTION
601	P0539601	PISTON ROLLER SHAFT
602	P0539602	PISTON ROLLER
603	P6003-2RS	BALL BEARING 6003-2RS
604	P0539604	SHAFT BEARING COLLAR
605	PSS03	SET SCREW 1/4-20 X 3/8
606	PS11	PHLP HD SCR 5/16-18 X 1 1/4
607	PN02	HEX NUT 5/16-18
608	PB12	HEX BOLT 5/16-18 X 1 1/4
609	PLW01	LOCK WASHER 5/16
610	P0539610	COMPRESSION SPRING
611	P0539611	SPECIAL PIN 10MM
612	PSB05	CAP SCREW 1/4-20 X 3/4
613	P0539613	PISTON SIDERAIL
615	P0539615	BEARING CAP
617	P0539617	HANDLE
618	PSB04	CAP SCREW 1/4-20 X 1/2
621	P0539621	BEARING HOUSING
622	P0539622	SPECIAL WASHER
623	P0539623	HANDLE
624	PSS08	SET SCREW 5/16-18 X 1/2
625	P0539625	HANDLE
628	P0539628	SPANNER NUT
629	P6205A	BALL BEARING 6205-2RS
630	P0539630	LEVER SHANK
631	P0539631	BEARING BRACKET PAD
632	P0539632	RUBBER ROLLER
633	PS01	PHLP HD SCR 10-24 X 1/2
634	P0539634	STEEL ROLLER
635	PK34M	KEY 5 X 5 X 20
636	PSB16	CAP SCREW 3/8-16 X 3/4
637	PW02	FLAT WASHER 3/8
638	P0539638	COMPRESSION SPRING
639	P0539639	FIXING SHAFT
640	P0539640	HOUSING
641	PW07	FLAT WASHER 5/16
642	PB03	HEX BOLT 5/16-18 X 1
644	P0539644	BRACKET (MALE)
645	P0539645	TUBE
646	P0539646	BASE

REF	PART #	DESCRIPTION
647	P0539647	BRACKET (FEMALE)
648	P0539648	PRESSURE PLATE
649	P0539649	FELT
650	P0539650	GRAPHITE PAD
651	P0539651	PLUG 25 MM
652	PLW07	LOCK WASHER 1/2
653	PB41	HEX BOLT 1/2-12 X 1 1/2
654	P05395104	BEARING UCC206
655	P0539655	FASTENING TUBE
656	PK11	KEY 5/16 X 5/16 X 1 3/16
657	PLW01	LOCK WASHER 5/16
658	PSB11	CAP SCREW 5/16-18 X 1 1/4
659	PS07	PHLP HD SCR 1/4-20 X 3/8
660	P0539660	COVER OF PULLEY
661	P0539661	PULLEY
662	P0539662	GREASE FITTING
663	PSS02M	SET SCREW M6-1 X 6
665	P05395204	BEARING UCC205
666	P0539666	FILTER
667	P0539667	BEARING HOUSING
670	P0446670	AXLE (G0446)
671	P0446671	ROLLER (G0446)
672	P0446672	ROLLER BRACKET (G0446)
673	P05395204	BEARING UCC205 (G0446)
674	PSS07	SET SCREW 1/4-20 X 1/2
675	PW04M	FLAT WASHER 10MM
676	P0446676	STUD (G0446)
677	PRP17M	ROLL PIN 3.5 X 24
678	P0446678	COMPRESSION SPRING (G0446)
679	PN02M	HEX NUT M10-1.5
680	PB12	HEX BOLT 5/16-18 X 1 1/4
681	PLW01	LOCK WASHER 5/16
682	P0446682	PLATEN (REAR) (G0446)
683	P0446683	ROLLER TOWER (LF) (G0446)
684	P0446684	ROLLER TOWER (LR) (G0446)
685	P0446685	ROLLER TOWER (RR) (G0446)
686	P0446686	ROLLER TOWER (RF) (G0446)
687	P0539687	PLATEN FRONT (G0446)
688	P0539688	PISTON BRACKET

Cabinet Assembly Diagram

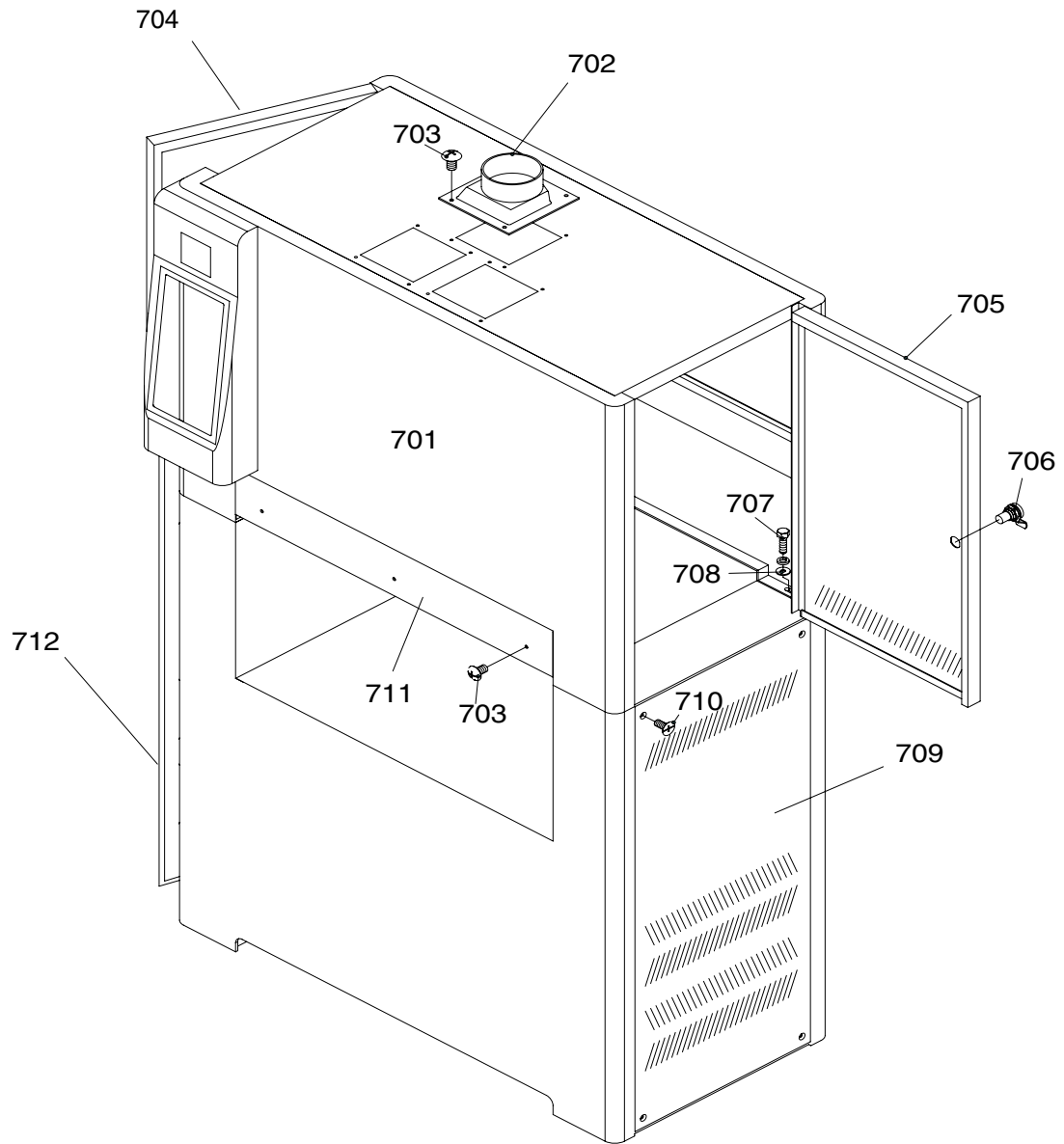

Parts List

REF	PART #	DESCRIPTION
701	P0446701	UPR FRAME COVER (G0446)
701	P0539701	UPR FRAME COVER (G0539/G0571)
702	P0539702	4" DUST PORT
703	PS14M	PHLP HD SCR M6-1 X 12
704	P0446704	LEFT DOOR (G0446)
704	P0539704	LEFT DOOR, (G0539/G0571)
705	P0446705	RIGHT DOOR, UPR FRAME (G0446)
705	P0539705	RIGHT DOOR, UPPER FRAME
706	P0539706	DOOR LOCK

REF	PART #	DESCRIPTION
707	PB07	HEX BOLT 5/16-18 X 3/4
708	PW07	FLAT WASHER 5/16
709	P0446709	RIGHT DOOR, LWR FRAME (G0446)
709	P0539709	R. DOOR, LWR FRAME (G0539/G0571)
710	PFH03	FLAT HD SCR 1/4-20 X 1/2
711	P0539711	FRONT PLATE
712	P0446712	LEFT DOOR, LWR FRAME (G0446)
712	P0539712	DOOR, LWR FRAME (G0539/G0571)

Tool Box and Accessories Diagram

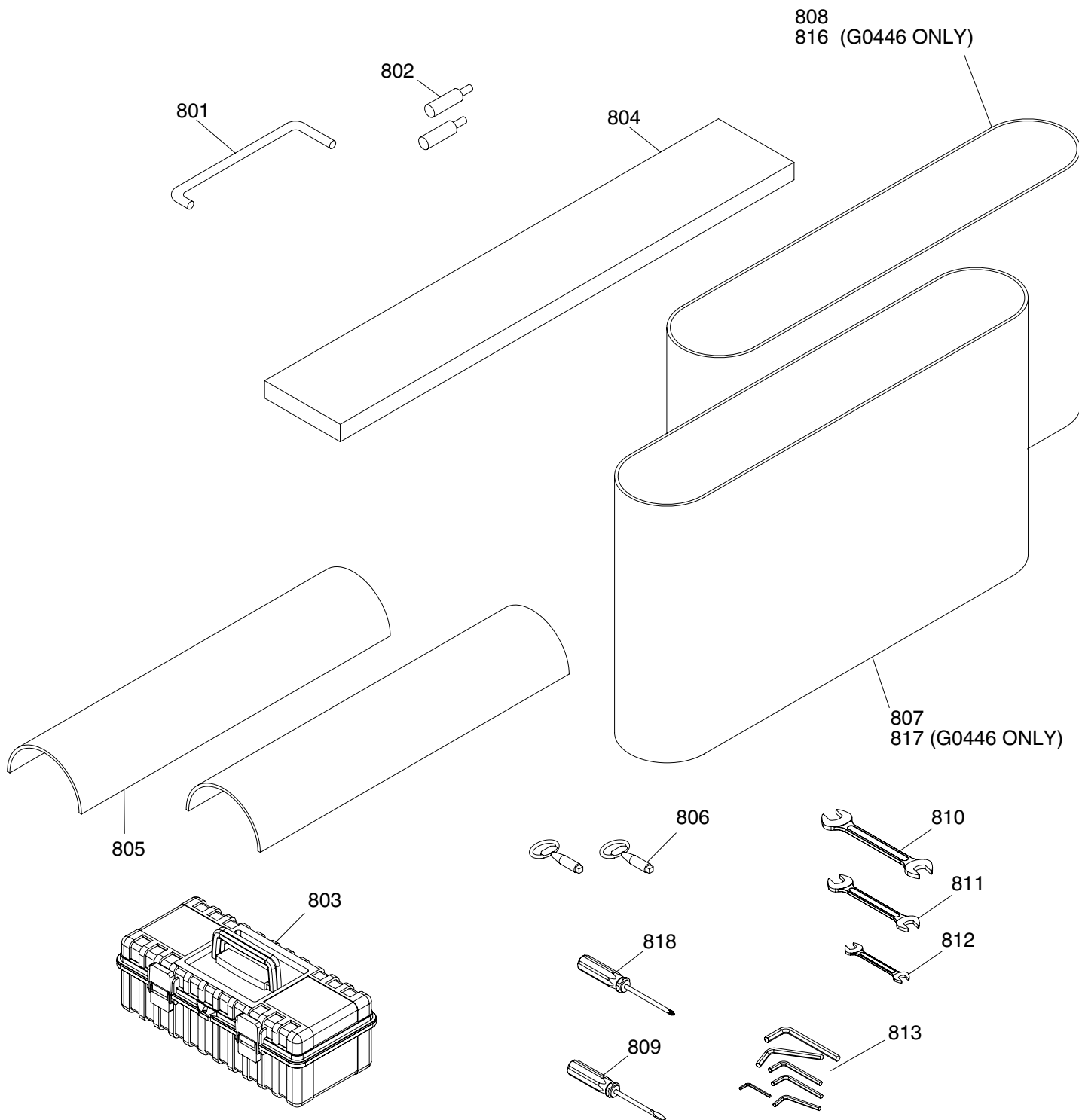

Parts List

REF	PART #	DESCRIPTION
801	P0539801	PLATEN REMOVAL TOOL
802	P0539802	LIMIT SWITCH TUBE
803	P0539803	TOOL BOX
804	P05390004	FELT
805	P0539805	GRAPHITE PAD
806	P0539806	DOOR KEY
807	P0539807	SANDPAPER: #100 (G0539/G0571)
808	P0539808	SANDPAPER: #180 (G0539/G0571)

REF	PART #	DESCRIPTION
809	P0539809	FLAT SCREWDRIVER
810	PWR1719	WRENCH 17 X 19
811	PWR1214	WRENCH 12 X 14
812	PWR810	WRENCH 8 X 10
813	P0539813	HEX WRENCH SET
816	P0446816	SANDPAPER: #100 (G0446)
817	P0446817	SANDPAPER: #180 (G0446)
818	P0539818	PHILLIP'S SCREWDRIVER

Troubleshooting

SYMPTOM	POSSIBLE CAUSE	CORRECTIVE ACTION
Motor will not start.	<ol style="list-style-type: none"> 1. Low voltage. 2. Open circuit in motor or loose connections. 	<ol style="list-style-type: none"> 1. Check power line for proper voltage. 2. Inspect all lead connections on motor for loose or open connections.
Motor will not start; fuses or circuit breakers blow.	<ol style="list-style-type: none"> 1. Short circuit in line cord or plug. 2. Short circuit in motor or loose connections. 3. Incorrect fuses or circuit breakers in power line. 	<ol style="list-style-type: none"> 1. Inspect cord or plug for damaged insulation and shorted wires. 2. Inspect all connections on motor for loose or shorted terminals or worn insulation. 3. Install correct fuses or circuit breakers.
Motor overheats.	<ol style="list-style-type: none"> 1. Motor overloaded. 2. Air circulation through the motor restricted. 	<ol style="list-style-type: none"> 1. Reduce load on motor. 2. Clean out motor to provide normal air circulation.
Motor stalls (resulting in blown fuses or tripped circuit).	<ol style="list-style-type: none"> 1. Short circuit in motor or loose connections. 2. Low voltage. 3. Incorrect fuses or circuit breakers in power line. 4. Motor overloaded. 	<ol style="list-style-type: none"> 1. Inspect connections on motor for loose or shorted terminals or worn insulation. 2. Correct the low voltage conditions. 3. Install correct fuses or circuit breakers. 4. Reduce load on motor.
Machine slows when operating.	<ol style="list-style-type: none"> 1. Feed rate too high. 2. Depth of cut too great. 	<ol style="list-style-type: none"> 1. Feed workpiece slower. 2. Reduce depth of cut.
Loud, repetitious noise coming from machine	<ol style="list-style-type: none"> 1. Pulley set screws or keys are missing or loose. 2. Motor fan is hitting the cover. 3. V-belt is defective. 	<ol style="list-style-type: none"> 1. Inspect keys and set screws. Replace or tighten if necessary. 2. Tighten fan or shim cover. 3. Replace V-belt. See Maintenance section.
Machine is loud, overheats or bogs down in the cut.	<ol style="list-style-type: none"> 1. Excessive depth of cut. 2. Dull or dirty sanding belt. 	<ol style="list-style-type: none"> 1. Decrease depth of cut. 2. Replace or clean sanding belt.
Rounded workpiece edges.	<ol style="list-style-type: none"> 1. Excessive depth of cut. 	<ol style="list-style-type: none"> 1. Reduce depth of cut.
Uneven thickness from left to right of board.	<ol style="list-style-type: none"> 1. Feed table not parallel to sanding roller. 2. Feed belt is worn. 	<ol style="list-style-type: none"> 1. Adjust the table. 2. Replace feed belt.
Workpiece slips on feed belt.	<ol style="list-style-type: none"> 1. Pressure rollers set too high. 2. Dirty feed belt. 3. Feed belt is worn. 	<ol style="list-style-type: none"> 1. Lower pressure rollers. 2. Clean feed belt. 3. Replace feed belt.
Straight strip of notches on workpiece.	<ol style="list-style-type: none"> 1. Pressure rollers are dirty or damaged. 	<ol style="list-style-type: none"> 1. Clean or repair pressure rollers.
Snake shaped marks on workpiece.	<ol style="list-style-type: none"> 1. Sanding belt damaged or dirty. 	<ol style="list-style-type: none"> 1. Clean or replace sanding belt.

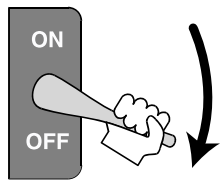

⚠ WARNING

For your safety, turn switch off and disconnect the machine from power source before troubleshooting the machine. Please refer to Section 5: Set Up to make corrections.

Troubleshooting

SYMPTOM	POSSIBLE CAUSE	CORRECTIVE ACTION
Lines across width of workpiece.	1. Sanding belt seam is open or damaged.	1. Repair or replace sanding belt.
Glossy spots or streaks on workpiece.	1. Worn sanding belt. 2. Rear pressure roller too low.	1. Replace sanding belt. 2. Raise rear pressure roller. (See warning in Pressure Roller section!)
Sanding belt clogs quickly.	1. Sanding belt grit too small for particular job. 2. Excessive depth of cut. 3. Wood is too moist.	1. Replace with a coarser grit sanding belt. 2. Reduce depth of cut. 3. Allow wood to dry out.
Sanding belt does not tension correctly; rollers slip under belt.	1. Low air pressure. 2. Air leaks in system.	1. Adjust air pressure to 75 PSI at primary regulator. 2. Inspect all hoses and connections for leaking air; use water on suspected area to detect bubbles.
Sanding belt runs off to one side, stopping the sander.	1. Air eye fork clogged. 2. Oscillation return valve closed. 3. Oscillation timing incorrect.	1. Clean the intake hole on the air eye fork. 2. Open valve. 3. Adjust oscillation timing.
Sanding belt will not start	1. Sanding belt is not tensioned. 2. Limit switches engaged. 3. Emergency stop plate engaged.	1. Tension sanding belt. 2. Center sanding belt so it is not touching the limit switches. 3. Make sure emergency stop switch is released.
Poor, non-aggressive sanding results.	1. Worn sanding belt. 2. Sanding belt loaded with sawdust.	1. Replace sanding belt with a new one. 2. Clean sanding belt to unload sawdust.
Conveyor belt not tracking in center.	1. Conveyor rollers moved out of adjustment.	1. Re-adjust conveyor rollers.
Conveyor belt slipping.	1. Conveyor rollers have incorrect tension. 2. Conveyor rollers contaminated with dirt or dust.	1. Adjust conveyor rollers to place more tension on . 2. Clean conveyor rollers.
Emergency brake stops slow.	1. Air pressure incorrect. 2. Air leak in system. 3. Brake rotor contaminated with oil. 4. Brake pads worn out.	1. Adjust air pressure to 75 PSI, 2. Find and fix air leaks. 3. Clean brake rotor with automotive brake parts cleaner. 4. Replace brake pads.
Grinding noise when braking.	1. Brakes severely worn out.	1. Replace brake pads, have rotor turned (possibly replaced).

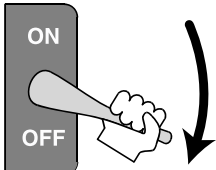

⚠ WARNING

For your safety, turn switch off and disconnect the machine from power source before troubleshooting the machine. Please refer to Section 5: Set Up to make corrections.

Warranty & Returns

Grizzly Industrial, Inc. warrants every product it sells for a period of **1 year** to the original purchaser from the date of purchase. This warranty does not apply to defects due directly or indirectly to misuse, abuse, negligence, accidents, repairs or alterations or lack of maintenance. This is Grizzly's sole written warranty and any and all warranties that may be implied by law, including any merchantability or fitness, for any particular purpose, are hereby limited to the duration of this written warranty. We do not warrant or represent that the merchandise complies with the provisions of any law or acts unless the manufacturer so warrants. In no event shall Grizzly's liability under this warranty exceed the purchase price paid for the product and any legal actions brought against Grizzly shall be tried in the State of Washington, County of Whatcom.

We shall in no event be liable for death, injuries to persons or property or for incidental, contingent, special, or consequential damages arising from the use of our products.

To take advantage of this warranty, contact us by mail or phone and give us all the details. We will then issue you a "Return Number," which must be clearly posted on the outside as well as the inside of the carton. We will not accept any item back without this number. Proof of purchase must accompany the merchandise.

The manufacturers reserve the right to change specifications at any time because they constantly strive to achieve better quality equipment. We make every effort to ensure that our products meet high quality and durability standards and we hope you never need to use this warranty.

Please feel free to write or call us if you have any questions about the machine or the manual.

Thank you again for your business and continued support. We hope to serve you again soon.



WARRANTY CARD

Name _____

Street _____

City _____ State _____ Zip _____

Phone # _____ Email _____ Invoice # _____

Model # _____ Order # _____ Serial # _____

The following information is given on a voluntary basis. It will be used for marketing purposes to help us develop better products and services. **Of course, all information is strictly confidential.**

1. How did you learn about us?

- Advertisement
- Card Deck
- Friend
- Website
- Catalog
- Other:

2. Which of the following magazines do you subscribe to?

- | | | |
|---|--|---|
| <input type="checkbox"/> Cabinet Maker | <input type="checkbox"/> Popular Mechanics | <input type="checkbox"/> Today's Homeowner |
| <input type="checkbox"/> Family Handyman | <input type="checkbox"/> Popular Science | <input type="checkbox"/> Wood |
| <input type="checkbox"/> Hand Loader | <input type="checkbox"/> Popular Woodworking | <input type="checkbox"/> Wooden Boat |
| <input type="checkbox"/> Handy | <input type="checkbox"/> Practical Homeowner | <input type="checkbox"/> Woodshop News |
| <input type="checkbox"/> Home Shop Machinist | <input type="checkbox"/> Precision Shooter | <input type="checkbox"/> Woodsmith |
| <input type="checkbox"/> Journal of Light Cont. | <input type="checkbox"/> Projects in Metal | <input type="checkbox"/> Woodwork |
| <input type="checkbox"/> Live Steam | <input type="checkbox"/> RC Modeler | <input type="checkbox"/> Woodworker West |
| <input type="checkbox"/> Model Airplane News | <input type="checkbox"/> Rifle | <input type="checkbox"/> Woodworker's Journal |
| <input type="checkbox"/> Modeltec | <input type="checkbox"/> Shop Notes | <input type="checkbox"/> Other: |
| <input type="checkbox"/> Old House Journal | <input type="checkbox"/> Shotgun News | |

3. What is your annual household income?

- \$20,000-\$29,000
- \$30,000-\$39,000
- \$40,000-\$49,000
- \$50,000-\$59,000
- \$60,000-\$69,000
- \$70,000+

4. What is your age group?

- 20-29
- 30-39
- 40-49
- 50-59
- 60-69
- 70+

5. How long have you been a woodworker/metalworker?

- 0-2 Years
- 2-8 Years
- 8-20 Years
- 20+ Years

6. How many of your machines or tools are Grizzly?

- 0-2
- 3-5
- 6-9
- 10+

7. Do you think your machine represents a good value? Yes No

8. Would you recommend Grizzly Industrial to a friend? Yes No

9. Would you allow us to use your name as a reference for Grizzly customers in your area?
Note: We never use names more than 3 times. Yes No

10. Comments: _____

CUT ALONG DOTTED LINE

FOLD ALONG DOTTED LINE

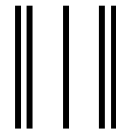

Place
Stamp
Here



GRIZZLY INDUSTRIAL, INC.
P.O. BOX 2069
BELLINGHAM, WA 98227-2069



FOLD ALONG DOTTED LINE

Send a Grizzly Catalog to a friend:

Name_____
Street_____
City_____ State_____ Zip_____

TAPE ALONG EDGES--PLEASE DO NOT STAPLE

grizzly.com

TOOL WEBSITE

Buy Direct and Save with Grizzly® – Trusted, Proven and a Great Value!

*Visit Our Website Today And Discover
Why Grizzly® Is The Industry Leader!*

- SECURE ORDERING
- ORDERS SHIPPED WITHIN 24 HOURS
- E-MAIL RESPONSE WITHIN ONE HOUR

-OR-

Call Today For A **FREE**
Full Color Catalog

1-800-523-4777

