

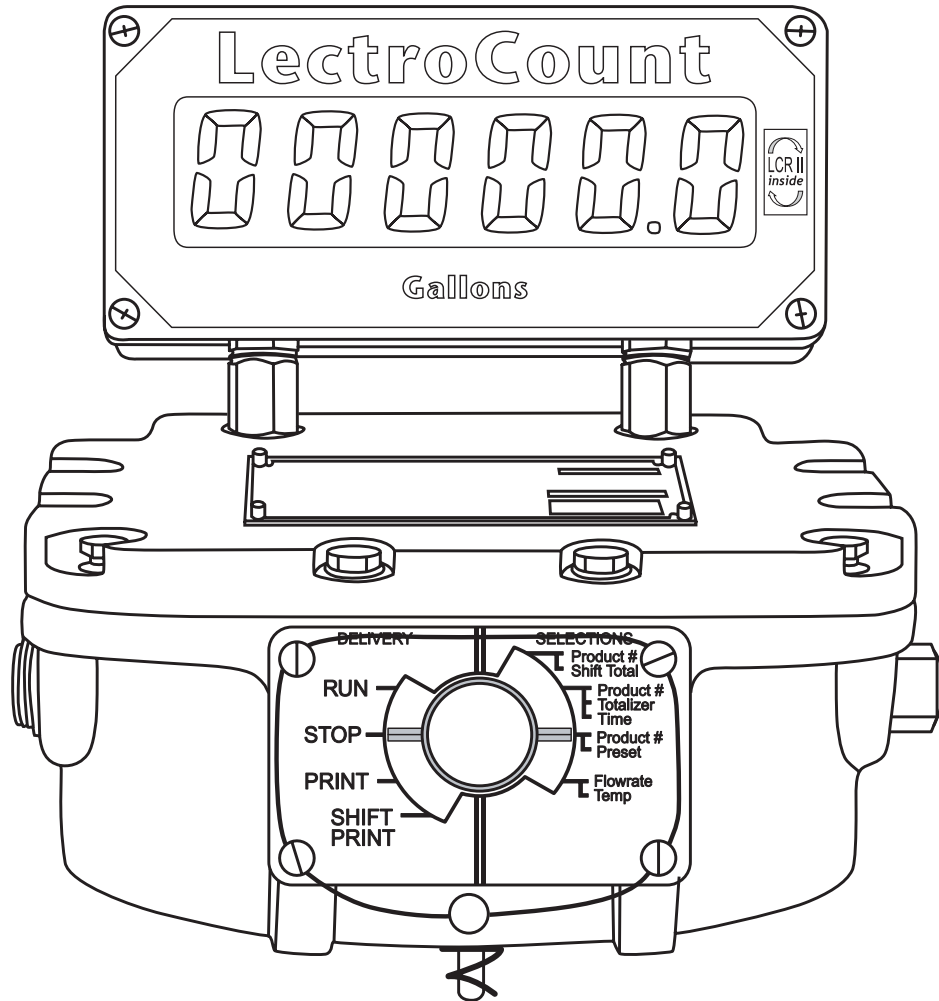

# Set-Up & Operation Manual

## LectroCount® LCR® Electronic Registers

(with SR210 software)  
E2650/E2651 Series Enclosure (Class I, Division 1)



# Table of Contents

---

Description	Page Number	
LCR System Components .....	4	Recalibration/Proving w/o a Lap Pad .....
LCR Specifications .....	5	Single Point Recalibration/Proving .....
Lap Pad Operation .....	6-8	Basic Operation w/o a Lap Pad .....
Lap Pad Overview .....	6	Delivery & Selections Menu .....
Navigating Top-Level Menus .....	7	RUN Position .....
Secondary Data Screens .....	8	STOP Position .....
Lap Pad Calibration & Set-Up .....	9-26	PRINT Position .....
Before Getting Started .....	9	SHIFT PRINT Position .....
Removing the LCR Switchplate .....	9	LCR Menu Flow Charts .....
Security .....	10	Weights & Measures Requirements .....
General Setup .....	10-13	LCR Troubleshooting Guide .....
System Calibration .....	14-16	Appendix A - Compensation Types &
Product & Shift Information .....	17-18	Parameters .....
Product Calibration .....	19-23	Appendix B - VT100 Emulation Codes .....
Multi-Point Calibration .....	24-26	Appendix C - Error Messages .....
Lap Pad Basic Operation .....	26-28	Appendix D - Lap Pad Menu Flow
Preset Delivery with Lap Pad .....	26-28	Charts .....
Diagnostics/Factory Calibration .....	29-30	Appendix E - W & M Prover Guide .....

---

## Publication Updates and Translations

The most current English versions of all Liquid Controls publications are available on our website, [www.lcmeter.com](http://www.lcmeter.com). It is the responsibility of the Local Distributor to provide the most current version of LC Manuals, Instructions, and Specification Sheets in the required language of the country or the language of the end user to which the products are shipping. If there are questions about the language of any LC Manuals, Instructions, or Specification Sheets, please contact your Local Distributor.

### ! WARNING

- Before using this product, read and understand the instructions.
- Save these instructions for future reference.
- All work must be performed by qualified personnel trained in the proper application, installation, and maintenance of equipment and/or systems in accordance with all applicable codes and ordinances.
- Failure to follow the instructions set forth in this publication could result in property damage, personal injury, or death from fire and/or explosion, or other hazards that may be associated with this type of equipment.

## Truck Delivery System

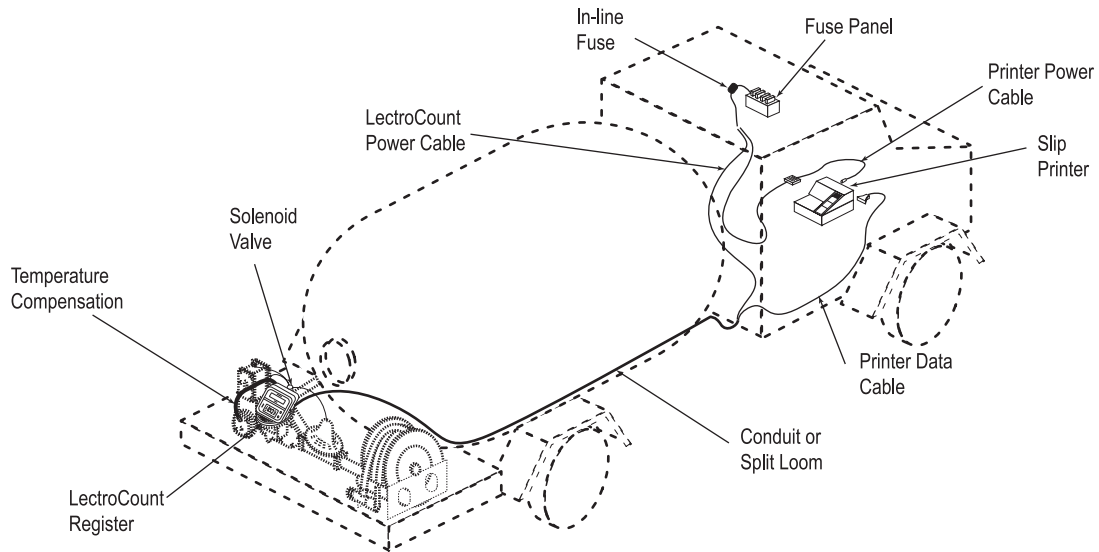

### ! WARNING

Power, input and output (I/O) wiring must be in accordance with the area classification for which it is used (Class I, Div 1). For North America, installations must be per the U. S. National Electrical Code, NFPA 70, or the Canadian Electrical Code in order to maintain Class I, Division 1 ratings. This may require using connections or other adaptations in accordance with the requirements of the authority having jurisdiction.

**WARNING:** Explosion Hazard - Substitution of components may impair suitability for Class I, Division 1 applications.

**WARNING:** Explosion Hazard - When in hazardous locations, turn power OFF before replacing or wiring modules.

**WARNING:** Explosion Hazard - Do NOT disconnect equipment unless power has been switched OFF or the area is known to be Non-Hazardous.

# LCR System Components

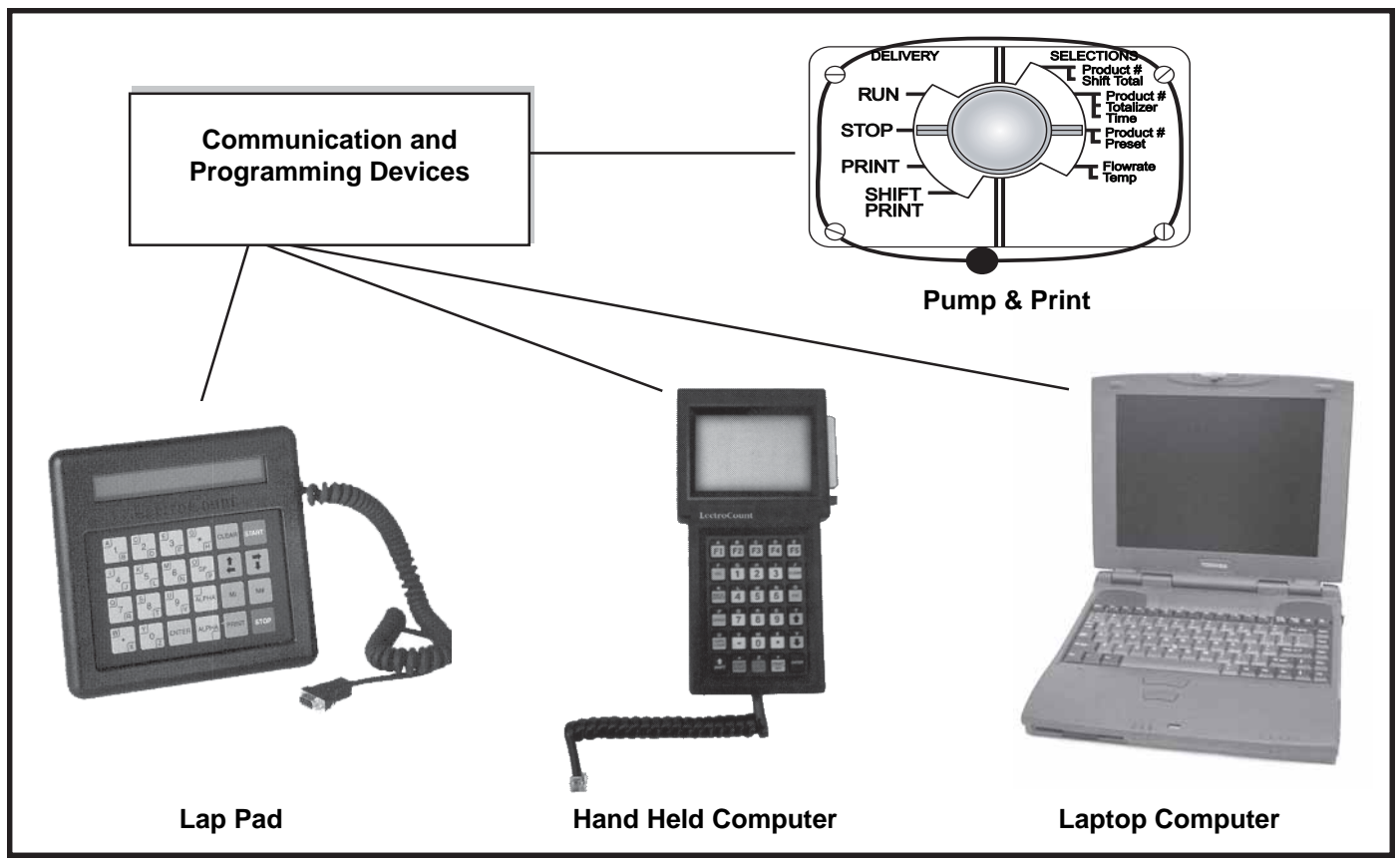
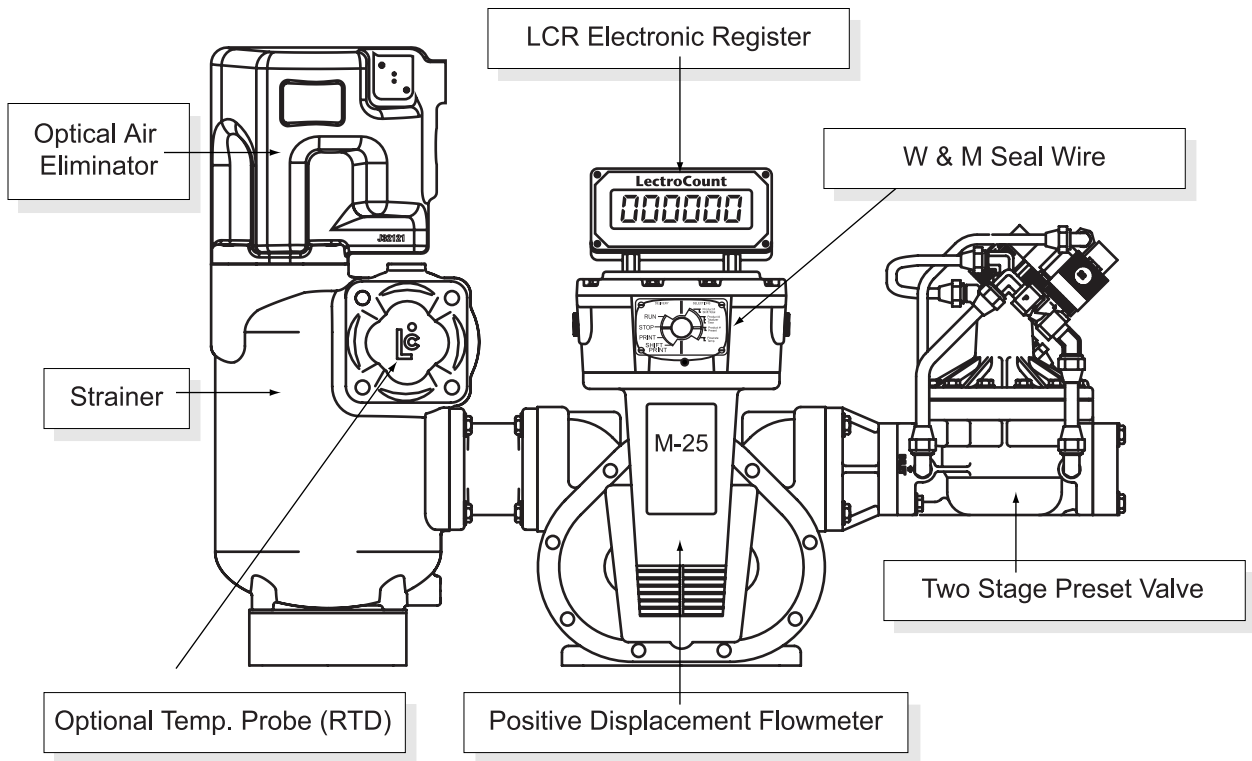

# LCR Specifications

The LectroCount LCR is a microprocessor based electronic register that offers the same advanced operation as previous LectroCount models but with additional benefits. The LectroCount LCR features include:

- Full Weights & Measures Approvals
- Class I, Division 1, Group C, D safety approvals.
- NEMA 4X enclosure, Weights & Measures sealable
- Five conduit connections
- Operation with most flowmeters. LCR accepts input from PD, Amplified Turbine, Electromagnetic, and Mass flowmeters.
- Multi-Point Calibration for improved meter accuracy over the full flow range
- Multiple Product Calibration
- Optional Electronic Temperature Volume Compensation (ETVC)
- Large character, backlit LCD display
- 10 digit totalizer
- Two control buttons provide:
  - **"SELECT"** for accessing internal menus
  - **"INCREASE"** for adjusting internal programmable data
  - Push button presetting, rate of flow indication, temperature indication, product selection and more.

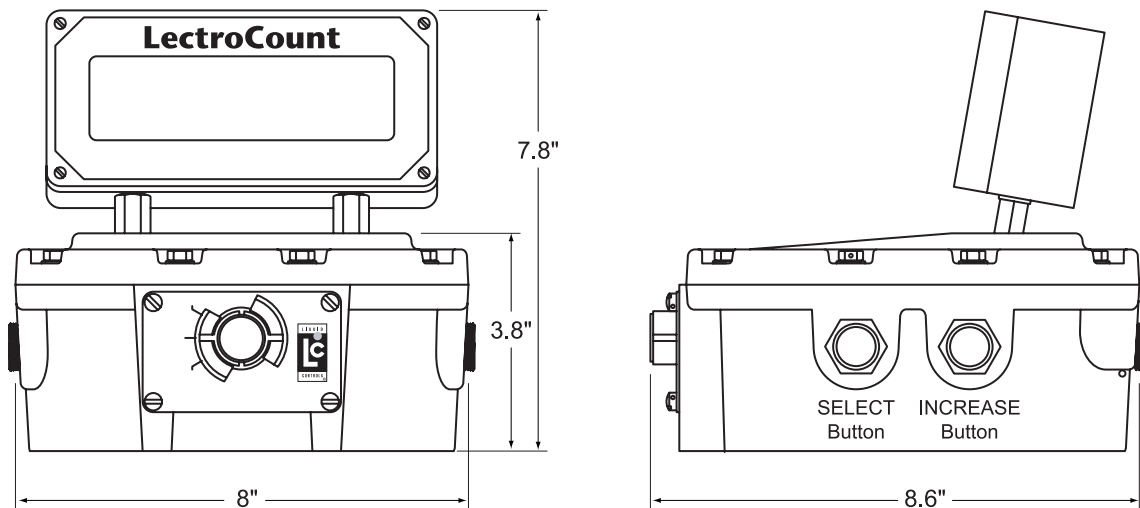

<p><b>Specifications</b></p> <p><b>Environmental:</b>                  Enclosure: Class I, Division 1, Group C &amp; D                  NEMA 4X                  Operating Temp. Range: -40° to 158°F (-40° to 70°C)</p> <p><b>Approvals:</b>                  US Weights &amp; Measures NTEP COC 86-022                  Canada Weights and Measures AV2342</p> <p><b>Communications:</b>                  RS232/485, Lap Pad                  Hand Held, PC</p> <p><b>Printer:</b>                  Epson, Okidata, and Blaster Models</p>	<p><b>Electrical:</b></p> <p><b>Power:</b> +9 to 28 VDC, 3A Maximum (including solenoid valves)</p> <p><b>Inputs:</b>                  Temperature Input: 4-Wire Platinum RTD                  Pulse Inputs: +5 to 28-volt peak to peak, open collector                  Single Channel or Quadrature                  0-1500 Hz per Channel</p> <p><b>Outputs:</b>                  Control Valve (2): Open drain transistor for 2-stage valve control,                  1 A Max. per channel</p> <p>Auxiliary (2): Open drain transistor for general-purpose                  auxiliary control. Aux (1), 1 A Max                  Aux. (2), 150 mA Max.</p> <p>Scaled Pulse Output: Open drain output, 1 A Max.</p>
--	--

# Lap Pad Operation

---

## LAP PAD OVERVIEW

This section of the manual provides instructions for the initial set-up, calibration and operation of your LCR Electronic Register using the Liquid Controls Lap Pad data entry device. This section should first be scanned to become familiar with the components of the system, the layout and format of the document, the basic menu (screens) and data entry required. This section should then be carefully followed as the system is being set up and calibrated. (Refer to the Installation Manual for instructions on connecting the Lap Pad for use with the LCR).

Following is a brief overview of the top level Program Menu screens.



### DELIVERY & PRESET

This menu includes up to seven data screens for setting preset quantities, product prices, taxes and other relevant delivery information.

### PRODUCT & SHIFT INFORMATION

This menu includes four secondary data screens for viewing product types and basic parameters pertaining to shift information.

### GENERAL SET-UP

This menu includes five secondary data screens for setting the internal clock and calendar, initializing sale and ticket number counters, setting the no-flow timer and defining data to be printed on tickets.

### SYSTEM CALIBRATION

This menu includes five secondary screens for entering Meter ID, printer selections, units of measure, rounding and truncating.

### PRODUCT CALIBRATION

This menu includes eight secondary screens for assigning unique codes to products; defining product types such as gasoline, diesel fuel, LPG, etc.; and compensation parameters such as base temperature for temperature compensated deliveries.

### DIAGNOSTICS

This menu includes four secondary screens for viewing system parameters such as software version, supply voltage, and pulser diagnostic information.

### SECURITY

This menu includes one secondary screen for user password and system security.

## NAVIGATING TOP-LEVEL MENUS

When the LCR is powered up with a Lap Pad attached, the Lap Pad will briefly display a copyright message for two seconds followed by the initial top-level menu.

*DELIVERY & PRESET*  
*Press Enter or Scroll with ARROW keys.*

Press the ↓ key to navigate to the next top-level menu.

Continue pressing the ↓ key to scroll through the rest of the top-level menus (as seen below).

Press the ↑ key to navigate in the opposite direction.

Selecting a secondary menu is accomplished by pressing the **ENTER** key.

Pressing the ↓, ↑, **M1** and **M#** keys allows for navigation of the secondary level screens.

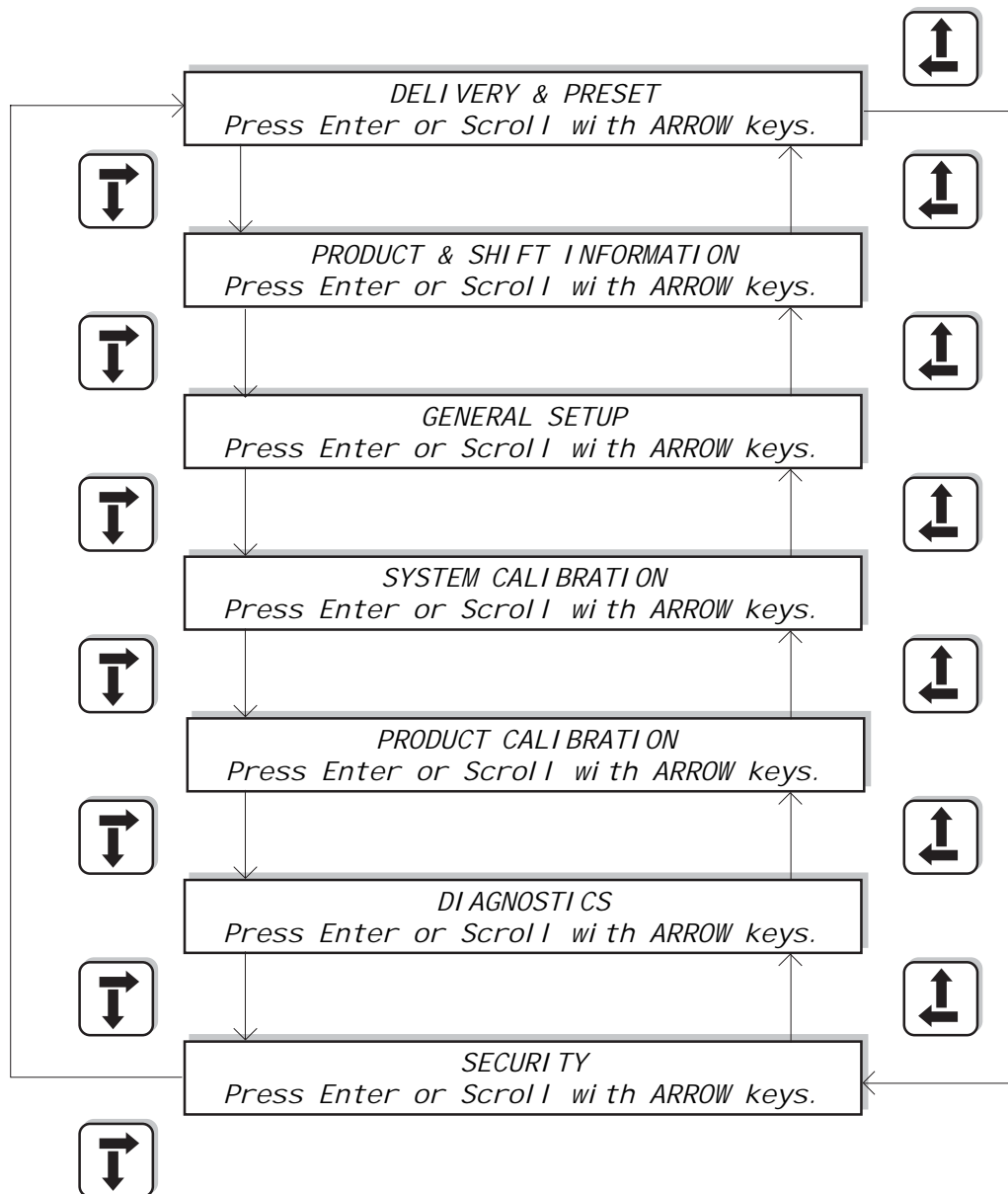

# Lap Pad Operation

---

## SECONDARY DATA SCREENS

Each of the top-level menus has a secondary level consisting of one or more screens. Each screen is divided into one or more fields where data may be entered or information displayed. Access to data entry is dependent on the following:

### DATA FIELD TYPE:

Some fields are for display only and data entry is not necessary (e.g. **DIAGNOSTICS** and **FLOW RATE**).

### PASSWORD PROTECTION:

The LCR has a user-definable password that allows the system to be locked. This feature authorizes a supervisor to limit access to certain fields. An operator can still view all data fields whether the unit is locked or unlocked. Data entry in general system set-up functions (e. g. **NO-FLOW TIMER** and **PRESET TYPE**) are still accessible if the system is locked.

### SELECTOR SWITCH:

The multi-position Selector Switch on the front of the LCR™ has a **CALIBRATION** position that is accessed by removing a Weights & Measures sealable plate. This allows data entry in the metrologically significant fields (e. g. **COMPENSATION TYPE**, **TEMPERATURE PULSES/UNIT** and others).

When a secondary menu is entered by pressing the **ENTER** key, the cursor will be positioned in the top line of the first field. Pressing **↓** will cause the cursor to move to the next field.

Repeatedly pressing **↓** will move the cursor through the fields from left to right. After the right most field, the next secondary menu screen will be displayed. The cursor will be in the first field. After the last field of the last screen, the cursor returns to the top line of the first field of the first screen.

NOTE: Pressing the **"M#"** key scrolls forward to the next secondary menu. Pressing **"M1"** returns the display to the top-level menu from any secondary level menu.

The cursor indicates if data can be entered or changed in the field below it. If the cursor is flashing, pressing **ENTER** will move the cursor to the second line in the field and data may be entered or changed. In some cases, data is entered using the keypad. In other cases, data is entered by selecting entries using the **↓↑** keys. A **"^"** Character in the top line of the field indicates that a scroll list is used for the field. In fields that have **⌘**, a **"YES"** or **"NO"** response is selected. Information that is entered through the Lap Pad or selected from a menu of choices is stored in the LCR by pressing **ENTER**. The cursor also moves back to the top line of that menu screen.

Menu maps of the screens accessible in the system are located in Appendix D on pages 50-57.

The next section covers Calibration & Set-up using the Lap Pad.



## BEFORE GETTING STARTED

- Make sure that the Lap Pad or other data entry device is connected to the LCR register as described in the LCR Installation Manual.
- When proving the LCR system, follow the pre-test and inspection procedures established by Weights & Measures authorities. The primary indicating and recording element on a vehicle-mounted LCR is the 6-digit liquid crystal display.
- Weights & Measures inspectors are responsible for determining if the truck metering and recording elements of the system are within tolerance. To make this determination, the system should be tested under normal conditions.
- The LCR is pre-programmed with common values for many of the programmable parameters. These values should be checked to ensure that they fit the specific requirements of the given installation. Detailed instructions for checking and changing these values follow later in this publication.
- Changes cannot be made to metrologically significant data without first removing the Switchplate and its associated Weights & Measures seal. The security level for each of the programming screens is defined in the following table:

<b>OPERATOR</b>	<i>Operator can change or enter data.</i>
<b>PASSWORD</b>	<i>System must be unlocked.</i>
<b>WEIGHTS &amp; MEASURES</b>	<i>Switch must be in the CALIBRATION position to enter or change data.</i>
<b>FACTORY</b>	<i>Read only (can not be changed by operator).</i>
<b>NOT EDITABLE</b>	<i>Read only (can not be changed by operator).</i>

**NOTE:** This table applies to the lower line of the Lap Pad display only. The upper line cannot be edited.

## STEP 1: REMOVE THE LCR SWITCHPLATE

- Remove the lead seal and wire assembly from the LCR Switchplate (if previously sealed by Weights & Measures authorities).
- Remove the four screws that secure the Switch Plate over the red Selector Switch located on the front of the LCR, and remove the plate.
- Rotate the Selector Switch counter clockwise to the 6 o'clock (CALIBRATION) position to permit access to all programming fields (except FACTORY).

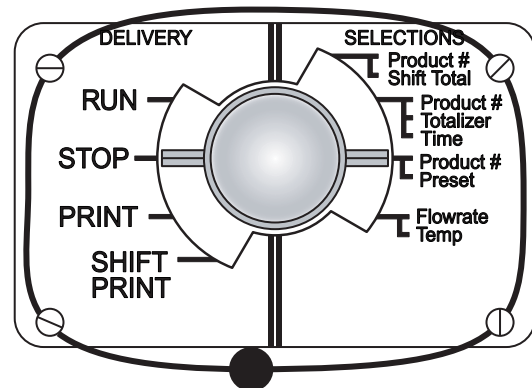

# Lap Pad Calibration & Set-Up

---

## STEP 2: SECURITY

Press the **M1** Key to access a top-level menu. Press **↓** to scroll to the **SECURITY** menu. Press **ENTER** to gain access to the secondary menu.

### *Security - Screen 1*

<b>USER KEY</b>	<b>SECURITY^</b>	
0001	UNLOCKED	

### **USER KEY (Password)**

Use this field to enter the owner/office password. To enter a password, press **ENTER** to drop into the data entry field. Enter a password using up to 10 alphanumeric characters. Press **ENTER**. This password will be required in the future to unlock the system in order to gain access to secured menu and data entry fields. This password will also be needed to change the time using the LCR control buttons. If it is desired to have access to time adjustment, the **USER KEY** must be numeric only and contain 5 digits.

Press **↓** and the cursor will move to:

### **SECURITY^**

This field is used to lock the system. Press **ENTER** to drop to the bottom field. Use **↑** to scroll between **LOCKED** and **UNLOCKED**. Press **ENTER** to select the desired option. While the system is **LOCKED**, the operator is unable to change system data other than **GROSS** and **NET PRESETS**, **PRODUCT CODE**, **PRODUCT NAME**, and **NO-FLOW TIMER**.

**NOTE:** The LCR is shipped **LOCKED** from the factory.

Press **M1** to return to the top-level menu. Press **↓** to scroll to **GENERAL SETUP**.

## STEP 3: GENERAL SETUP

The fields in this menu are not specific to any of the four possible product calibrations, therefore the Selector Switch does not have to be in the **CALIBRATION** position to allow data entry in many of these fields and changes can be made without breaking Weights & Measures seals.

Press **ENTER** and the cursor will move to:

### *General Setup - Screen 1*

<b>DATE FORMAT^</b>	<b>DATE</b>	<b>TIME HH: MM: SS</b>
MM/DD/YY	10/6/2002	9:05:24

### **DATE FORMAT^**

This field is used to determine in which format the date will be displayed and printed: month first or day first. Press **ENTER** and the cursor will drop to the second line. Now you can use the arrow keys to select the format, either month first ( **MM/DD/YY**) or day first ( **DD/MM/YY**). When the choice is displayed, press **ENTER** and the cursor will move back to the top line.

Press **↓** and the cursor will move to:

**DATE MM/DD/YY** (or **DD/MM/YY** depending on the previous field).

This field is used to set the LCR internal calendar. The LCR updates its calendar and will print the correct date on delivery tickets. Press **ENTER** and the cursor will drop to the bottom line. Enter the current date on the keypad using only numbers. Press **ENTER** and the cursor will move back to the top line.

## STEP 3: GENERAL SETUP CONTINUED

Press ↓ and the cursor will move to:

### TIME HH:MM:SS

This field is used to set the LCR internal clock. The time, like the date, is updated by the LCR and printed on the delivery tickets. Press **ENTER** and the cursor will drop to the bottom line. Enter the current hour, minutes, and seconds. Use military time (e.g. press 13:01:15 for 1:01:15 PM).

**HINT:** To synchronize the clock to the second, press **ENTER** when the appropriate second is reached. Press **ENTER** and the cursor will move to the top line.

Press ↓ and the cursor will move to:

### General Setup - Screen 2

SALE#	TICKET#	UNIT ID	NO-FLOW TIMER
25	1	123456	180

### SALE #

This field is used to track the number of transactions that the LCR processes. The LCR will increment the field each time a delivery is made, wrapping around to **000000** after **999999**. Press **ENTER** and the cursor will drop to the bottom line. Key in the starting **SALE #**, up to 6 digits. Press **ENTER** and the cursor will move to the top line.

Press ↓ and the cursor will move to:

### TICKET #

This is similar to the sale number. It will increment every time that the LCR prints a ticket. If multiple or duplicate tickets are used for transactions, the ticket number will be incremented more than the sale number. **NOTE:** If a **TICKET #** of **0** is entered, the **TICKET #** will not print on the delivery ticket and the **TICKET #** will not increment. Press **ENTER** and the cursor will drop to the bottom line. Key in the starting **TICKET #**, up to 6 digits. Press **ENTER** and the cursor will move to the top line.

Press ↓ and the cursor will move to:

### UNIT ID

This is a number that can be used to identify the driver, location, or truck that the LCR is associated with. Press **ENTER** and the cursor will drop to the bottom line. Key in your **UNIT ID**, up to 10 characters. Press **ENTER** and the cursor will move to the top line.

Press ↓ and the cursor will move to:

### NO-FLOW TIMER

The **NO-FLOW TIMER** is an internal timer in the LCR that starts running when the LCR senses that there is no longer any product moving through the meter. If the timer counts up to its set point, the LCR will assume that the delivery is over, and print a ticket. The timer can be set to count up to **3600** seconds before printing the ticket. This feature can be deactivated by entering **0** seconds, allowing multiple tanks to be filled at a location. The timer helps to ensure that deliveries are not split between authorized and unauthorized locations. **NO-FLOW TIMER** is not active in prover mode. If the value is set to **0** or any value greater than **180**, "Multiple Deliveries at One Site" will be printed on the delivery ticket.

**NOTE:** Internal timer is activated once the flow delivery has started and a minimum amount of flow (1 gallon or 5 liters) is registered and then is stopped.

# Lap Pad Calibration & Set-Up

---

## STEP 3: GENERAL SETUP CONTINUED

### NO-FLOW TIMER CONTINUED

Press **ENTER** and the cursor will drop to the bottom line. Enter the desired **NO-FLOW TIMER** value in seconds. Press **ENTER** and the cursor will move to the top line.

Press ↓ and the cursor will move to:

### *General Setup - Screen 3*

<b>PRESET</b> <sup>^</sup>	<b>PRESET TYPE</b> <sup>^</sup>	<b>PULSE OUTPUT EDGE</b> <sup>^</sup>
<b>GROSS</b>	<b>CLEAR</b>	<b>RISING</b>

### PRESET<sup>^</sup>

Available preset options include **NET**, **BOTH**, **GROSS**, and **NONE**. Selecting **NONE** will disable pre-setting. Presetting **NET**, **GROSS**, or **BOTH** is allowed. Press **ENTER** and the cursor will drop to the bottom line. Use ↓ to scroll through the available preset options. When the desired option is displayed, press **ENTER** and the cursor will move to the top line.

Press ↓ and the cursor will move to:

### PRESET TYPE<sup>^</sup>

There are four preset types:

#### **CLEAR**

Resets the preset values to 0 after the current delivery is ended.

#### **RETAIN**

Maintains the preset values to be used again on the next delivery.

#### **MULTIPLE**

Allows more than one preset to be run before a delivery ticket is printed. Printing must be initiated by a **PRINT** command.

#### **INVENTORY**

Maintains the remaining preset amount between deliveries (i. e. indicates the remaining volume in the vehicle tank).

Press **ENTER** and the cursor will drop to the bottom line. Use ↓ to scroll through the four options. When the desired choice is displayed, press **ENTER** and the cursor will move to the top line.

Press ↓ and the cursor will move to:

### PULSE OUTPUT EDGE<sup>^</sup>

This feature allows you to synchronize the calibrated pulse output waveform with the requirements of an external system that uses that LCR signal. There are two choices: **RISING** or **FALLING**. (Some counters increment on rising, others on falling pulse edges. Refer to equipment technical manual to determine the specific requirements of your connected equipment). Press **ENTER** and the cursor will drop to the bottom line. Use ↓ to scroll between the two choices. When the desired choice is displayed, press **ENTER** and the cursor will move to the top line.

Press ↓ and the cursor will move to:

## STEP 3: GENERAL SETUP CONTINUED

### *General Setup - Screen 4*

HDR^	TICKET HEADER LINE
1	

#### HDR^

This field is used to select the line number of the ticket header that will be edited in the following field. Press **ENTER** and the cursor will drop to the bottom line. Use the **↓↑** keys to scroll through the numbers from **1** to **12**. When the desired choice is displayed, press the **ENTER** key and the cursor will move to the top line.

Press **↓** and the cursor will move to:

#### TICKET HEADER LINE

This feature is useful when using blank (as opposed to pre-printed) tickets. The field allows the fuel dealer to enter the company name, address, telephone number, etc., which will be printed on each delivery ticket. This field (35-character max.) allows you to enter or edit ticket header labels. The Header Line will scroll in tandem with the **HDR #** selected in the previous field. Any lines that are left blank will not be printed on the ticket.

**NOTE:** Header Lines 11 and 12 can only be edited in the **CALIBRATION** mode. **TICKET HEADER LINE 11** only prints when **AUX OUT 1** is **ON** or **ON DURING DELIVERY** as shown on the Lap Pad Screen. **TICKET HEADER LINE 12** only prints when **AUX OUT 2** is **ON** or **ON DURING DELIVERY**. After data has been entered, press **ENTER**.

Press **↓** and the cursor will move to:

### *General Setup - Screen 5*

PRINT GROSS & PARAM?	VOL CORRECTED MSG?
YES	YES

#### PRINT GROSS & PARAM?

This allows one to choose whether to have the gross volume and compensation parameter printed on the ticket if the product is temperature compensated. Press **ENTER** and the cursor will drop to the bottom line. Use **↓** to scroll between the two choices, **YES** or **NO**. When the desired choice is displayed, press the **ENTER** key and the cursor will move to the top line.

Press **↓** and the cursor will move to:

#### VOL CORRECTED MSG?

This field allows you to print a message on the delivery ticket indicating that delivery volume has been corrected to a base temperature (defined later in **SYSTEM CALIBRATION**). The user has the option (**YES** or **NO**) to print the message. Press **ENTER** and the cursor will drop to the bottom line. Use **↓** to scroll between the two choices, **YES** or **NO**. When the desired choice is displayed, press the **ENTER** key and the cursor will move to the top line. Press **M1** to return to the top of the **GENERAL SETUP** menu.

# Lap Pad Calibration & Set-up

## STEP 4: SYSTEM CALIBRATION

From the top-level menu, use ↓ to scroll to **SYSTEM CALIBRATION**. Press **ENTER** and the cursor will move to:

### *System Calibration - Screen 1*

<i>METER ID</i>	<i>TICKET?</i>	<i>PRINTER</i>
<i>1234567890</i>	<i>YES</i>	<i>EPSON NewFontB</i>

#### **METER ID**

This number allows you to uniquely identify an LCR/Meter combination. If the LCR is part of a multiple-meter system, it is important that this number be unique. It is recommended that the meter serial number be entered here. This number will print on the calibration/diagnostic ticket. Press **ENTER** and the cursor will drop to the bottom line. Key in 1 to 10 characters. Press **ENTER** and the cursor will move back to the top line.

Press ↓ and the cursor will move to:

#### **TICKET?**

This field allows you to choose whether or not a ticket will be required for each delivery. Most Weights & Measures governed truck applications will require a ticket. If **YES** is chosen, the LCR will not allow deliveries to be made unless a ticket is in the printer; the printer is operational and the previous delivery ticket has been printed in its entirety. Press **ENTER** and the cursor will drop to the bottom line. Use ↓ to scroll between the two choices, **YES** or **NO**. When the desired choice is displayed, press **ENTER**. The cursor will move to the top line. When **NO** is selected, tickets are not mandatory but will print if a printer is connected and available to print a ticket.

Press ↓ and the cursor will move to:

#### **PRINTER^**

This field allows you to select a printer type. The six choices are **EPSON NewFontB** (select for use with EPSON 200 Roll and EPSON 220 Roll), **EPSON NewFontA** (select for use with EPSON TM-T88iii), **EPSON OldFontA** (select for use with EPSON 290 Slip and EPSON 295 Slip), **EPSON OldFontB** (select for use with EPSON 300 Roll), **OKIDATA ML184T** (select for use with Okidata ML184T), **BLASTER** (select for use with Cognitive Solutions Thermal Printer). Press **ENTER** and the cursor will drop to the bottom line. Use ↓ to scroll between the choices. When the desired choice is displayed, press **ENTER** and the cursor will move back to the top line.

Press ↓ to move to:

### *System Calibration - Screen 2*

<i>UNITS^</i>	<i>RATE BASE^</i>	<i>DECIMAL^</i>	<i>RESIDUAL^</i>
<i>GALONS</i>	<i>PER MINUTE</i>	<i>TENTHS</i>	<i>ROUND</i>

#### **UNITS^**

This field is used to choose the units of flow measurement. The choices are **GALLONS**, **LITRES**, **CUBIC M**, **LBS** (pounds), **KGS** (kilograms), **BARRELS**, and **OTHER**. Press **ENTER** and the cursor will drop to the bottom line. Use the ↓↑ keys to scroll through the choices. When the desired choice is displayed, press **ENTER** and the cursor will move to the top line.

Press ↓ and the cursor will move to:

#### **RATE BASE^**

Use this field to select the time unit for measurement on the flow rate display. The choices are **PER HOUR**, **PER MINUTE** and **PER SECOND**. Press **ENTER** and the cursor will drop to the bottom line. Use ↓ to scroll between the three choices. When the desired choice is displayed, press **ENTER** and the cursor will move to the top line.

Press ↓ and the cursor will move to:

## STEP 4: SYSTEM CALIBRATION CONTINUED

### DECIMAL<sup>^</sup>

This field allows you to choose between whole units, tenths and hundredths of a unit. Press **ENTER** and the cursor will drop to the bottom line. Use **↓** to scroll between **WHOLE**, **TENTHS**, and **HUNDR**. When the desired choice is displayed press **ENTER** and the cursor will move to the top line.

Press **↓** and the cursor will move to:

### RESIDUAL<sup>^</sup>

Volumes less than the least significant digit can be rounded into that digit or truncated (thrown away) depending on the selection mode. Press **ENTER** and the cursor will drop to the bottom line. Press **↓** to scroll between **ROUND** and **TRUNCATE**. When the desired choice is displayed press **ENTER** and the cursor will move to the top line.

Press **↓** and the cursor will move to:

### System Calibration - Screen 3

TEMP	OFFSET	T TEMP <sup>^</sup>	RTD SLP	RTD OFS
25.53	0.00	DEG. F	0.024724	2.817

### TEMP

This field displays the current temperature reading from the RTD temperature probe and allows one to enter a corrected value from a Weights & Measures thermometer. If the LCR is not equipped with the optional Electronic Temperature Volume Compensation (ETVC) Kit, this field will read "--".

#### To make a correction:

Run enough product through the meter to allow the temperature to stabilize. Compare the **TEMP** reading with the current Weights & Measures thermometer reading. If the readings are different, the Weights & Measures reading should be entered. Press **ENTER** and the cursor will drop to the bottom line. Enter the new value. The new value will overwrite the previous one and the **OFFSET** field will be recalculated by the LCR. Offset adjustments are limited to  $\pm 0.3^{\circ}\text{C}$  ( $\pm 0.54^{\circ}\text{F}$ ). Adjustments greater than this limit require replacement of the RTD probe. Press **ENTER** and the cursor will move to the top line.

Press **↓** and the cursor will move to:

### OFFSET

The offset represents the difference between the official Weights & Measures reading and the LCR RTD reading. The offset is automatically calculated if an entry is made in the previous field.

If a Weights & Measures thermometer reading was not entered in the previous field, subtract the value listed in the **TEMP** field from the Weights & Measures measurement. Key in the difference in the offset field. If the number is negative, use "\*" on the Lap Pad to change the sign. Adjustment is limited to  $\pm 0.3^{\circ}\text{C}$  ( $\pm 0.54^{\circ}\text{F}$ ). Any adjustment larger than  $\pm 0.3^{\circ}\text{C}$  ( $\pm 0.54^{\circ}\text{F}$ ) generates a **RANGE ERROR** message and requires replacement of the RTD probe.

Press **↓** and the cursor will move to:

# Lap Pad Calibration & Set-up

---

## STEP 4: SYSTEM CALIBRATION CONTINUED

### T UNIT^

This field allows you to choose the temperature units - Degrees Fahrenheit or Degrees Celsius. Press **ENTER** and the cursor will drop to the bottom line. Use **↓** to scroll between the two choices, **DEG. F** and **DEG. C**. When the desired choice is displayed, press **ENTER** and the cursor will move to the top line.

Press **↓** and the cursor will move to:

### RTD SLP

Factory calibration setting only. Press **↓** and the cursor will move to:

### RTD OFS

Factory calibration setting only. Press **↓** and the cursor will move to:

#### *System Calibration - Screen 4*

<i>FLOW DIR^</i>	<i>LAST CALIBRATED</i>	<i>LCR #</i>
<i>--&gt;</i>	<i>7/11/2002 11:44</i>	<i>250</i>

### FLOW DIR^

This field allows you to match the LCR flow direction to the meter's pulse output. If the counter runs backwards, this arrow should be changed. The choices are **←** or **→**. Press **ENTER** and the cursor will drop to the bottom line. Use **↓** to scroll between the two choices. When the desired choice is displayed, press **ENTER**.

Press **↓** and the cursor will move to:

### LAST CALIBRATED

This field contains the date and time of the last calibration. It cannot be edited.

Press **↓** and the cursor will move to:

### LCR #

This field contains the node address for RS485 communication. Enter a number between **1** and **250**. The default value is **250**.

Press **↓** and the cursor will move to:

#### *System Calibration - Screen 5*

<i>CALIB#</i>	<i>CALIB EVENT</i>	<i>CONFIG EVENT</i>
<i>34</i>	<i>19</i>	<i>1</i>

### CALIB #

For metrology use only. This is the number of times the calibration switch position has been entered. DISPLAY ONLY.

### CALIB EVENT

For metrology use only. This is the number of times the calibration has been changed. DISPLAY ONLY.

### CONFIG EVENT

For metrology use only. This is the number of times the configuration has been changed. DISPLAY ONLY.

Press the **M1** key to return to the top of the **SYSTEM CALIBRATION** menu. Then press **↓** to scroll to **PRODUCT & SHIFT INFORMATION**.



## STEP 5: PRODUCT & SHIFT INFORMATION

Press **ENTER** and the cursor will move to:

### *Product & Shift - Screen 1*

#^	PROD TYPE	SHIFT START	DLVRY
1	DISTILLATE	7/01/2002 1:44:00	22

#### #^ (Product Number)

This field is used to select one of four possible product types/calibrations. Press **ENTER** and the cursor will drop to the bottom line. Use **↓** to scroll through the numbers **1-4**. When the product number is selected for which corresponding **PROD TYPE** information will be entered, press **ENTER** and the cursor will move to the top line.

Press **↓** and the cursor will move to:

#### PROD TYPE^

This field will scroll along with the #^ (Product Number) that is shown in the first field. The product type **AMMONIA, AVIATION, DISTILLATE, GASOLINE, METHANOL, LPG, LUBE OIL** or "blank" can be selected. Press **ENTER** and the cursor will drop to the bottom line. Press **↓** to scroll through the available options. When the desired choice is displayed, press **ENTER** and the cursor will move to the top line.

Press **↓** and the cursor will move to:

#### SHIFT START

The starting time and date for the current shift are shown here. DISPLAY ONLY.

#### DLVRY

This field shows the number of deliveries that have been made since the last time **CLR SHIFT** was set to **YES** or a shift ticket was printed. DISPLAY ONLY.

Press **↓** and the cursor will move to:

### *Product & Shift - Screen 2*

#^	SHIFT GROSS	SHIFT NET	UNITS
1	1647.6	0.0	GALLONS

#### #^ (Product Number)

This field is used to select one of four possible product types/calibrations that can be set up in the LCR. At least one calibration must be set up to allow deliveries.

#### SHIFT GROSS

This field displays the gross number of units that have been delivered through the meter since the last time the **CLR SHIFT** field was set to **YES** or a shift ticket was printed. **SHIFT GROSS** is the sum total of the delivery ticket gross quantities during the current shift. DISPLAY ONLY.

Press **↓** and the cursor will move to:

#### SHIFT NET

This field displays the net (temperature compensated) number of units that have been delivered through the meter since the last time **CLR SHIFT** field was set to **YES** or a shift ticket was printed. **SHIFT NET** is the sum total of the delivery ticket net quantities during the current shift. DISPLAY ONLY.

# Lap Pad Calibration & Set-up

---

## STEP 5: PRODUCT & SHIFT INFORMATION CONTINUED

### UNITS^

From this field, a unit of measure is selected. Choose **GALLONS**, **LITRES**, **CUBIC M**, **LBS** (pounds), **KGS** (kilograms), **BARRELS**, or **OTHER**.

Press ↓ and the cursor will move to:

### *Product & Shift - Screen 3*

#^	GROSS TOTAL	NET TOTAL	UNITS
1	6193.8	0.0	GALLONS

### #^ (Product Number)

This field is used to select one of four possible product types/calibrations. At least one calibration must be set up in the LCR to allow deliveries.

### GROSS TOTAL

This field shows the total gross volume that has gone through the register since the field was last initialized. This value can be initialized to any positive number if the Selector Switch is in the **CALIBRATION** position. This is a "live" totalizer and will count regardless of a delivery being active.

Press ↓ and the cursor will move to:

### NET TOTAL

This field shows the total net volume that has gone through the register since the field was last initialized. This value can be initialized to any positive value if the Selector Switch is in the **CALIBRATION** position. This is a "live" totalizer and will count regardless of a delivery being active.

Press ↓ and the cursor will move to:

### UNITS^

From this field, a unit of measure is selected. Choose from **GALLONS**, **LITRES**, **CUBIC M**, **LBS** (pounds), **KGS** (kilograms), **BARRELS**, or **OTHER**. If more than one product is entered, the above listed procedures should be repeated for each.

Press ↓ and the cursor will move to:

### *Product & Shift - Screen 4*

CLR SHIFT?
NO

### CLR SHIFT?

This field is used to print a **SHIFT TICKET** and clear the **SHIFT GROSS**, **SHIFT NET**, and **DLVRY** fields. If **YES** is selected, the shift fields will be reset to **0** after the shift ticket is printed. After the ticket is printed, this field will revert to **NO**. If **TICKET?** is set to **NO**, shift totals can be cleared without printing a shift ticket. Press **ENTER** and the cursor will drop to the bottom line.

Press the ↓ key to scroll between **YES** and **NO**. When the desired entry is displayed, press **ENTER** and the cursor will return to the top line.

## STEP 6: PRODUCT CALIBRATION

Press **M1** to return to the top-level menu. Press **i** to scroll to **PRODUCT CALIBRATION**.

There are four product calibrations that can be set up in the LCR. The products are calibrated one at a time. Press **ENTER** and the cursor will move to:

### *Product Calibration - Screen 1*

#^	CODE	PRODUCT NAME	PRODUCT TYPE
1	12345	Product Name	DISTILLATE

#### #^(Product Number)

This number will correspond to one of the four product types/calibrations that can be set up in the LCR. At least one calibration must be set up to allow deliveries. Press **ENTER** and the cursor will drop to the bottom line. Use **i** to scroll between the four choices, **1** to **4**. Press the **ENTER** key when the desired choice is displayed.

Press **↓** and the cursor will move to:

#### CODE

A five character alphanumeric code can be entered here. The code will correspond to one of the products within this product type. This code can also be entered in the **DELIVERY & PRESET** menu. Press **ENTER** and the cursor will drop to the bottom line. Enter a code that will aid the operator in identifying the product or one that has been specified for use by a host computer system. Press **ENTER** and the cursor will move to the top line.

Press **↓** and the cursor will move to:

#### PRODUCT NAME

The **PRODUCT NAME** contains a product description (up to 18 alphanumeric characters) that will print on the delivery ticket. NOTE: Make sure that the **PRODUCT NAME** matches up with the **PROD TYPE^**, **#^**, and **CODE** that are also entered on this screen. This name can also be entered in the **DELIVERY & PRESET** menu. Press **ENTER** and the cursor will drop to the bottom line. Enter the appropriate **PRODUCT NAME**. Press **ENTER** and the cursor will move to the top line.

Press **↓** and the cursor will move to:

#### PROD TYPE^

This field will scroll along with the **#^(Product Number)** that is shown in the first field. The product type **AMMONIA**, **AVIATION**, **DISTILLATE**, **GASOLINE**, **METHANOL**, **LPG**, **LUBE OIL** and **"blank"** can also be set up in the **PRODUCT & SHIFT INFORMATION** menu.

Press **↓** and the cursor will move to:

### *Product Calibration - Screen 2*

COMPENSATION TYPE	COMP PARAM	BASE TEMP
TABLE 54B	653	15.0

#### COMPENSATION TYPE^

Select the type of Temperature Volume Compensation to be used for this specific product number. No deliveries are permitted if the LCR is configured for temperature compensation and the temperature circuit has failed or the measured temperature is out of the specified range (see Table in Appendix A).

# Lap Pad Calibration & Set-up

## STEP 6: PRODUCT CALIBRATION CONTINUED

### COMPENSATION TYPE^ CONTINUED

Scroll through the choices: **Linear F**, **Linear C**, **API Table 24**, **API Table 54**, **API Table 6B**, **API Table 54B**, **API Table 54C**, **API Table 54D**, **NH3** or **NONE**. If "**NONE**" is selected, deliveries will be in gross quantities only. Net Quantities will read " **0**" on the screen. Refer to the Compensation Types and Parameters table (Appendix A) when choosing the type of compensation to be used.

### COMP PARAM

This field contains the coefficient of expansion, the standard density, API gravity, or the specific gravity that will be used with the **COMPENSATION TYPE** selected in the previous field. Enter a number based on the **COMPENSATION TYPE** and the product that is being metered. Refer to the Compensation Types and Parameters table found in Appendix A.

### BASE TEMP

This field is used to set the base temperature for temperature compensated deliveries when using either the **Linear C** or **Linear F Compensation** type. It defaults to either **60°F** or **15°C** when using either the **API tables** or **NH3**. Enter a number. Press **ENTER** to return to the top line.

Press ↓ and the cursor will move to

#### *Product Calibration - Screen 3*

#^	PULSE/UNIT	PROVER QTY	UNITS
1	2222.000000	0.000	GALLONS

### #^ (Product Number)

This number will correspond to one of the four product types/calibrations that can be set up in the LCR. At least one calibration must be set up to allow deliveries.

### PULSES/UNIT

This field is the number of pulse edges that the LCR counts per unit of measure. (Only Gross Volume applies). This number is used to scale the **PROVER QTY** (Gross).

### PROVER QTY

This field displays the metered volume. When this value is overwritten with the actual **PROVER QTY**, a new **PULSES/UNIT** (k-Factor) will be recalculated automatically. (Only for Calibration use.) If this is the initial calibration for this meter, first enter the rest of the **PRODUCT CALIBRATION** data before entering this field. Once the other **PRODUCT CALIBRATION** parameters are entered, press **START** and fill up a reliable prover. As the prover is filled, this field will increment, displaying a volume based on the existing **PULSES/UNIT** parameter. After the prover has been filled, press **PRINT** and enter the exact prover reading in place of the reading displayed. When the new reading is entered, the **PULSES/UNIT** parameter will be recalculated by the LCR, "zeroing" out the error. Refill the prover. Check to ensure that the prover and LCR gross volumes are within tolerance limits. If not, enter the new prover volume, and retest.

Press ↓ and the cursor will move to:

#### *Product Calibration - Screen 4*

GROSS QTY	PRESET	REMAINING	UNITS
0.0	0.0	-----	GALLONS

### GROSS QTY

This field displays the gross delivery total for the product being delivered. DISPLAY ONLY.

## STEP 6: PRODUCT CALIBRATION CONTINUED

### PRESET

The Gross Preset amount is entered here. When this amount is reached the valve outputs are turned off.

### REMAINING

The number of units remaining to be delivered on the current **GROSS DELIVERY** preset is displayed.

### UNITS^

Choose the units of measure to be displayed. The choices are **GALLONS**, **LITRES**, **CUBIC M**, **LBS** (pounds), **KGS** (kilograms), **BARRELS**, or **OTHER**. Use the **hi** keys to scroll through the choices. Press **ENTER** to make a selection.

Press **↓** and the cursor will move to:

#### Product Calibration - Screen 5

GROSS QTY	NET QTY	UNITS^	TEMP
0.0	0.0	GALLONS	23.4

### GROSS QTY

This field displays the gross delivery total for the product being delivered.

### NET QTY

This field will show the **NET QTY** of the delivery in progress, or the last delivery if the meter isn't running. The net quantity is calculated by multiplying the gross quantity by the calculated Volume Correction Factor (VCF). If no compensation is active, it is set to zero. The VCF calculation is based in part on the temperature reading from the **RD** and the offset that was calculated/entered in the **SYSTEM CALIBRATION** menu.

### UNITS^

Choose the units of measure to be displayed. The choices are **GALLONS**, **LITRES**, **CUBIC M**, **LBS** (pounds), **KGS** (kilograms), **BARRELS**, or **OTHER**. Use the **↑↓** keys to scroll through the choices. Press **ENTER** to make a selection.

### TEMP

This displays the actual product temperature if the optional ETVC Kit is installed.

Press **↓** and the cursor will move to:

#### Product Calibration - Screen 6

S1 CLOSE	AUX MULT	AUT QTY	AUX UNIT^
0.0	0.000	0.0	LITRES

### S1 CLOSE

This number is used to set the dwell period if the LCR is controlling a two-stage valve or presetting with a one-stage valve. This represents the number of measurement units (e.g. **GALLONS**, **LITRES**) that are remaining on a preset delivery before the valve is placed in a bypass, trickle, or dwell mode. An **S1 CLOSE** value is needed for each of the four product numbers. Enter a number between **0** and **500**.

The number entered here will match up with the **#^(Product Number)** that was selected in the first field of this menu.

# Lap Pad Calibration & Set-up

---

## STEP 6: PRODUCT CALIBRATION CONTINUED

### AUX MULT

This field is used to convert the quantity delivered, (e.g. **GALLONS, LITRES**) to an alternate volume or mass unit such as **CUBIC METERS, LBS**, etc. The user must furnish an applicable conversion factor. If **AUX MULT** is set to **0**, it will not print on the delivery ticket. Example: To convert **GALLONS** to **LBS**, **AUX MULT** is calculated as follows:

$$\text{AUX MULT} = (\text{SpGr}) \times (8.345 \text{ lbs/gal})$$

(Where SpGr is the specific gravity.)

### AUX QTY

This field is used to display the volume delivered in terms of the alternate volume or mass unit.

### AUX UNIT^

This field is used to define the auxiliary unit of measure that will be printed on the delivery ticket, i.e., **GALLONS, LITRES, CUBIC M, LBS, KGS, BARRELS, or OTHER**.

Press ↓ and the cursor will move to:

#### *Product Calibration - Screen 7*

<i>PT^</i>	<i>RATE</i>	<i>UNITS^</i>	<i>RATE BASE^</i>	<i>%ERROR</i>
<i>1</i>	<i>0.00</i>	<i>GALLONS</i>	<i>PER MINUTE</i>	<i>0.000</i>

### PT^

This field is used to calibrate the meter/register at up to 10 different flow rates for each product type/calibration.

### RATE

This field displays actual flow rate during delivery. Enter the actual flow rate for multi-point calibration.

### UNITS^

Choose the units of measure to be displayed. The choices are **GALLONS, LITRES, CUBIC M, LBS** (pounds), **KGS** (kilograms), **BARRELS**, or **OTHER**. Use the **hi** keys to scroll through the choices. Press **ENTER** to make a selection.

### RATE BASE^

Choose the time unit for measurement on the flow rate display. The choices are units **PER HOUR, PER MINUTE** and **PER SECOND**. Use the **↑↓** keys to scroll through the choices. Press **ENTER** to make a selection.

### %ERROR

This field contains the **%ERROR** difference against the base number.

$$\%Error = \frac{(\text{Prover Qty} - \text{Meter Qty})}{\text{Prover Quantity}} \times 100$$

Press ↓ and the cursor will move to:

## STEP 6: PRODUCT CALIBRATION CONTINUED

### *Product Calibration - Screen 8*

<i>PT^</i>	<i>PROVER QTY</i>	<i>UNITS^</i>	<i>%ERROR</i>	<i>LINEAR^</i>
<i>1</i>	<i>0.000</i>	<i>GALLONS</i>	<i>0.000</i>	<i>SETUP</i>

#### **PT^**

This field is used to calibrate the meter/register at up to 10 different flow rates for each product type/calibration.

#### **PROVER QTY**

This field needs to contain the exact volume in the prover tank tested at actual flow rate. When an entry is made, the actual **%ERROR** (delivery) against the base number will be recalculated automatically.

#### **UNITS^**

Choose the units of measure to be displayed. The choices are **GALLONS**, **LITRES**, **CUBIC M**, **LBS** (pounds), **KGS** (kilograms), **BARRELS**, or **OTHER**. Use the **↑↓** keys to scroll through the choices. Press **ENTER** to make a selection.

#### **%ERROR**

This field contains the **%ERROR** difference against the base number.

$$\%Error = \frac{(Prover Qty - Meter Qty)}{Prover Quantity} \times 100$$

#### **LINEAR^**

Select **SETUP** for single-point calibration or when setting up multi-point calibration. Select **APPLIED** to activate multi-point calibration.

**NOTE:** See pages 23-24 for optional multi-point calibration instructions. If your LCR is set up for single-point calibration, this concludes the Initial Calibration and Set-up procedures. Proceed to Page 25 for **BASIC OPERATION** instructions.

The next section covers **Multi-Point Calibration**.

# Lap Pad Calibration & Set-up

## MULTI-POINT CALIBRATION

Multi-point calibration allows a flowmeter to be used over a wide range of flow rates without experiencing a loss in measurement accuracy due to the shape of the meter curve (usually at low flow rates). After determining the inaccuracy of the meter at a variety of flow rates and inputting that information into the LCR multi-point calibration table, accuracy corrections are then continuously made by the LCR based on the measured flow rate. There are two ways to obtain the information necessary to load the multi-point calibration table:

1. Manufacturer's data supplied with the meter can be entered directly.
2. The meter can be field calibrated by proving at various flow rates.

### 1. MANUFACTURER'S DATA TECHNIQUE

#### Step 1:

Go to Screen 7 of **PRODUCT CALIBRATION**. From the manufacturer's data sheet showing the accuracy at various flow rates, enter into **PT^1** the flow **RATE** and the delivery **%ERROR** corresponding to the maximum flow rate of the meter.

#### *Product Calibration - Screen 7*

<b>PT^</b>	<b>RATE</b>	<b>UNITS^</b>	<b>RATE BASE^</b>	<b>%ERROR</b>
<b>1</b>	<b>0.00</b>	<b>GALLONS</b>	<b>PER MINUTE</b>	<b>0.000</b>

#### Step 2:

Select up to nine additional points from the manufacturer's data sheet to characterize the remainder of the meter's accuracy curve and enter this data into **PT^2**, **PT^3**, etc., respectively, in descending order by rate. (While it is not necessary to enter the selected points in a specific order, it is desirable to do so because the LCR will re-sort the data and arrange it in descending order by rate when it is **APPLIED**.) To enter negative **%ERROR** values, first enter the number then press the "\*" key to display the "-" sign. Errors that can occur during multi-point table data entry include:

#### **DUPLICATE FLOW RATE ERROR**

The same flow rate value was entered twice.

#### **RANGE ERROR**

A **%ERROR** outside the **±3.0%** limit was entered.

#### **POINT SELECTION TIPS:**

- Because the LCR uses a piece-wise linear interpolation method of correction, it is desirable to use more data points along segments of the accuracy curve that have the greatest curvature (typically in the low flow rate region).
- Where the meter curve already approximates a straight line (in the high flow rate region), use fewer of the available points.

#### Step 3:

Set the **LINEAR^** field to **APPLIED** and enter it. This puts the linearizing algorithm into effect. If the error message **ADJACENT POINTS OUT OF 0.25% RANGE** is displayed, **APPLIED** will not take effect and the points will need to be reselected to ensure that no two points adjacent to each other are more than 0.25% apart in **%ERROR**.

#### Step 4:

Field prove the meter at the normal high flow rate of the system. Adjust the **PULSES/UNIT** in Screen 3 of the **PRODUCT CALIBRATION** menu by entering the actual **PROVER QTY** (see Page 19) to obtain accuracy within tolerance limits.



## MULTI-POINT CALIBRATION CONTINUED

### Product Calibration - Screen 3

#^	PULSE/UNIT	PROVER QTY	UNI TS
1	2222.000000	0.000	GALLONS

#### Step 5:

Refill the prover at the same flow rate as Step 4 to verify that the meter remains within tolerance limits. Assuming that the data provided by the meter manufacturer is correct, and that proper technique was used for selecting and entering the multi-point table, it should be possible to fill the prover at any flow rate within the linearized range and obtain an error near zero.

## 2. FIELD PROVING TECHNIQUE

When the meter's accuracy is not provided by the manufacturer, points to enter into the multi-point calibration table need to be determined by field proving at various flow rates.

#### Step 1:

Start a proving run of the meter while viewing **PRODUCT CALIBRATION** - Screen 3 at the normal high flow rate of the system while the **LINEAR^** field is in the **SETUP** mode. With the prover full, press **PRINT** and adjust the **PULSES/UNIT** by entering the actual **PROVER QTY** (see Page 22).

### Product Calibration - Screen 3

#^	PULSE/UNIT	PROVER QTY	UNI TS
1	2222.000000	0.000	GALLONS

#### Step 2:

Go to **PRODUCT CALIBRATION** - Screen 7. With **PT^** set to 1 and **LINEAR^** still set to **SETUP**, start a new prover run at the same flow rate as Step 1. During prover filling, note the maximum **RATE** that is displayed. When the prover is filled, press **PRINT**. Advance to **PRODUCT CALIBRATION** - Screen 8. Enter the volume delivered to the prover in **PROVER QTY**. The **%ERROR** field will then display the calculated error for that rate. This should be a very small value since Step 1 "zeroed" the meter at the same rate. Return to **PRODUCT CALIBRATION** - Screen 7 and enter the maximum flow rate observed during prover filling in **RATE** for **PT^ 1**.

### Product Calibration - Screen 7

PT^	RATE	UNI TS^	RATE BASE^	%ERROR
1	0.00	GALLONS	PER MINUTE	0.000

#### Step 3:

With **PT^** set to the next point and **LINEAR^** still set to **SETUP**, start a prover run at a different flow rate. During prover filling, note the maximum **RATE** that is displayed. When the prover is filled, press **PRINT**. Advance to **PRODUCT CALIBRATION** - Screen 8. Enter the volume delivered to the prover in **PROVER QTY**. The **%ERROR** field will then display the calculated error for that rate. Return to **PRODUCT CALIBRATION** - Screen 7 and enter the maximum flow rate observed during prover filling in **RATE** for that **PT^**.

#### Step 4:

Continue proving at other flow rates using additional **PT^** numbers following the same procedure as Step 3. A minimum of three points is recommended (high, medium and low flow) to obtain a good fit to the curve. All ten points can be used to obtain optimum results. Any unused points should be left at **RATE=0** and **%ERROR=0**.

# Lap Pad Calibration & Set-up

---

## MULTI-POINT CALIBRATION CONTINUED

### Step 5:

Set the **LINEAR<sup>^</sup>** field to **APPLIED** and enter it. This puts the linearizing algorithm into effect. The LCR will re-sort the multi-point table and display the points in descending order by **RATE**. Do not be alarmed if the data changes in a given **PT<sup>^</sup>**. If the error message **ADJACENT POINTS OUT OF 0.25% RANGE** is displayed, **APPLIED** will not take effect and more points will need to be added to ensure that no two points adjacent to each other are more than **0.25%** apart in **%ERROR**.

---

## Lap Pad Basic Operation

### PRESET DELIVERY WITH A LAP PAD

If a terminal or Lap Pad is attached to the LCR serial port, it can be used to preset the delivery volume. The product number is selected in the first screen of the **DELIVERY & PRESET** menu and the **GROSS** or **NET PRESET** is entered in the third or fourth screen. (NOTE: The **NET PRESET** screen will only be displayed if the product being delivered is temperature compensated). If the Selector Switch has been left in the **RUN** position, a delivery will begin when the **START** key is pressed on the Lap Pad or terminal. Product will then be delivered until the **NET** or **GROSS PRESET** amount is reached, at which point the delivery will be halted.

A delivery ticket will be printed:

- As soon as the preset volume is reached and if **CLEAR** or **RETAIN** has been selected
- If the **PRINT** key is pressed
- If the **NO-FLOW TIMER** times out

If both **NET** and **GROSS PRESETS** are non-zero, the delivery will end when the lower of the two is reached.

If the preset type is set to **MULTIPLE**, the valve will close when the preset amount is reached. The operator can continue that delivery, making additional "drops" of the same quantity or preset amounts. The preset amount can be changed between drops. The delivery ends when the **PRINT** key is pressed or the Selector Switch is placed in the **PRINT** position. The delivery ticket will show the total **GROSS** and/or **NET** volume delivered. If the **NO-FLOW TIMER** is not set to **0**, the delivery will end if the timer times out between drops.

Preset may also be controlled directly from the LCR. This feature is described on Page 34.

The **DELIVERY & PRESET** menu group is the only one needed to make preset deliveries.

#### *Delivery & Preset - Screen 1*

# <sup>^</sup>	CODE	PRODUCT NAME	PRODUCT TYPE <sup>^</sup>
1	12345	PRODUCT NAME	<b>DI STILLATE</b>

#### #<sup>^</sup> (PRODUCT)

This field is used to select the product type that will be delivered. Scroll through numbers **1-4** and select the product.

#### CODE

The code associated with the product name and type is displayed here and can be changed.

#### PRODUCT NAME

The product name associated with the product code and type is displayed here and can be changed.

## PRESET DELIVERY WITH A LAP PAD CONTINUED

### PRODUCT TYPE^

This field displays the product type previously selected in **CALIBRATION**.

Press ↓ to advance to:

#### *Delivery & Preset - Screen 2*

<i>GROSS COUNT</i>	<i>NET COUNT</i>	<i>UNI TS</i>
<i>0.0</i>	<i>0.0</i>	<i>GALLONS</i>

### GROSS COUNT

This field displays a running total of the gross number of units for the current delivery. **DISPLAY ONLY.**

### NET COUNT

This field displays a running total of the net number of units for the current delivery. **DISPLAY ONLY.**

### UNITS^

This field displays delivery units selected during **CALIBRATION: GALLONS, LITRES, CUBIC M, LBS, KGS, BARRELS, and OTHER.**

Press ↓ to advance to:

#### *Delivery & Preset - Screen 3*

<i>NET COUNT</i>	<i>PRESET</i>	<i>REMAINING</i>	<i>UNI TS</i>
<i>0.0</i>	<i>0.0</i>	<i>-----</i>	<i>GALLONS</i>

(NOTE: This screen displays only if "Preset" is set to **NET** or **BOTH** in General Setup - Screen 3 and the current product is temperature compensated).

### NET COUNT

This field displays a running total of the net number of units for the current delivery. **DISPLAY ONLY.**

### PRESET

The **NET PRESET** amount can be entered here. A preset option of **NET** or **BOTH** must have been selected in **GENERAL SETUP**.

### REMAINING

This field displays the number of units remaining for the current delivery. **DISPLAY ONLY.**

### UNITS^

This field displays delivery units selected during **CALIBRATION: GALLONS, LITRES, CUBIC M, LBS, KGS, BARRELS, and OTHER.**

Press ↓ to advance to:

#### *Delivery & Preset - Screen 3*

<i>GROSS COUNT</i>	<i>PRESET</i>	<i>REMAINING</i>	<i>UNI TS</i>
<i>0.0</i>	<i>0.0</i>	<i>-----</i>	<i>GALLONS</i>

(NOTE: This screen displays only if "Preset" is set to **GROSS** or **BOTH** in General Setup - Screen 3 and the current product is temperature compensated).

### GROSS COUNT

This field displays a running total of the gross number of units for the current delivery. **DISPLAY ONLY.**

# Lap Pad Basic Operation

---

## PRESET DELIVERY WITH A LAP PAD CONTINUED

### PRESET

The **PRESET** amount can be entered here. A preset of **GROSS** or **BOTH** must have been selected in **GENERAL SETUP**.

### REMAINING

This field displays the number of units remaining for the current delivery. **DISPLAY ONLY**.

### UNITS^

This field displays delivery units selected during **CALIBRATION: GALLONS, LITRES, CUBIC METERS, LBS, KGS, BARRELS, and OTHER**.

Press ↓ to advance to:

#### *Delivery & Preset - Screen 5*

<i>PRICE/UNIT</i>	<i>TAX/UNIT</i>	<i>%TAX</i>
<i>0.000</i>	<i>0.000</i>	<i>0.000</i>

### PRICE/UNIT

Enter value.

### TAX/UNIT

Enter unit tax if applicable.

### %TAX

Enter % Tax rate if applicable.

Press ↓ to advance to:

#### *Delivery & Preset - Screen 6*

<i>SUBTOTAL</i>	<i>TAX</i>	<i>TOTAL</i>
<i>0.000</i>	<i>0.000</i>	<i>0.000</i>

### SUBTOTAL

Price per unit times quantity. **DISPLAY ONLY**.

### TAX

Total of all taxes for delivery. **DISPLAY ONLY**.

### TOTAL

Sum of **SUBTOTAL** plus **TAX**. **DISPLAY ONLY**.

Press ↓ to advance to:

#### *Delivery & Preset - Screen 7*

<i>AUX OUT 1^</i>	<i>AUX OUT 2^</i>
<i>ON DURING DELIVERY</i>	<i>FLOW DIRECTION</i>

### AUX OUT 1^

This field activates optional outputs, e. g. pump control, additive injection, alarms, etc. Choices are **OFF**, **ON**, **ON DURING DELIVERY** or **MONITOR FLOWRATE**. **MONITOR FLOWRATE** becomes active at the beginning of each delivery. If the flowrate meets or exceeds 40 units/time, the output deactivates. If the flowrate does not meet or exceed 40 units/time, the output remains active.

### AUX OUT 2^

This field can be programmed to indicate **FLOW DIRECTION** or it can be programmed similar to the **AUX OUT 1^** functions of **OFF**, **ON**, or **ON DURING DELIVERY**.

## DIAGNOSTICS

Most of the **DIAGNOSTICS** fields are for **DISPLAY ONLY**. They contain information that can be useful in troubleshooting.

### *Diagnostics - Screen 1*

<b>DIAGNOSTIC MESSAGES<sup>^</sup></b>	<b>SUPPLY VOLTAGE</b>
<b>TVC ACTIVE</b>	<b>13.5</b>

#### **DIAGNOSTIC MESSAGES<sup>^</sup>**

This field allows an operator to check pending diagnostic messages. Press **ENTER** and the cursor will drop to the second line of the screen. Press **↓** to scroll through the list of messages. The last message is "END OF LIST".

#### **SUPPLY VOLTAGE**

The field shows the current supply voltage. The correct operating voltage is +9 to +28 VDC. **DISPLAY ONLY.** **NOTE: Voltage above +17 VDC will not indicate correctly.**

Press **↓** to advance to:

### *Diagnostics - Screen 2*

<b>SOFTWARE</b>	<b>LANGUAGE</b>	<b>TICKET</b>
<b>SR210v1.00</b>	<b>SL200v1.04</b>	<b>ST200v1.05</b>

#### **SOFTWARE**

The software number is shown here. This number is critical for any troubleshooting discussions with the Liquid Controls factory service personnel. **DISPLAY ONLY.**

#### **LANGUAGE**

The software number designating language selection (English, Spanish, etc.) is displayed here. **DISPLAY ONLY.**

#### **TICKET**

The software number designating the ticket format is displayed here. **DISPLAY ONLY.**

Press **↓** to advance to:

### *Diagnostics - Screen 3*

<b>GROSS COUNT</b>	<b>RATE</b>	<b>UNITS<sup>^</sup></b>	<b>RATE BASE<sup>^</sup></b>
<b>0</b>	<b>0.0</b>	<b>GALLONS</b>	<b>PER MINUTE</b>

#### **GROSS COUNT**

This field displays a running total of the gross number of units for the current delivery. **DISPLAY ONLY.**

#### **RATE**

This field displays the actual flow rate. **DISPLAY ONLY.**

#### **UNITS**

This field displays the units of measure for flow total.

#### **RATE BASE**

This field displays the time base for flow rate.

Press **↓** to advance to:

# Diagnostics/Factory Calibration

---

## DIAGNOSTICS CONTINUED

### *Diagnostics - Screen 4*

<b>PULSR FAULTS</b>
<u>0</u>

#### **PULSR FAULTS**

This field displays the number of quadrature pulser faults detected during the last delivery. **DISPLAY ONLY.**

---

## FACTORY CALIBRATION (ONLY ACCESSIBLE BY LC FACTORY PERSONNEL)

### *Factory Calibration - Screen 1*

<b>R100.0</b>	<b>R128.6</b>	<b>RAW ADC</b>	<b>RTD SLP</b>	<b>RTD OFS</b>
-105.2	2884.7	796	0.02475	2.605

#### **R100.0**

Used by qualified personnel to calibrate the temperature probe.

#### **R128.6**

Used by qualified personnel to calibrate the temperature probe.

#### **RAW ADC**

This is the raw value being returned by the A to D converter used by the temperature probe and can be used to assist qualified personnel in troubleshooting.

#### **RTD SLP**

The RTD Slope is displayed here. This value can assist qualified personnel in troubleshooting.

#### **RTD OFS**

The RTD Offset is displayed here. This value can assist qualified personnel in troubleshooting.

Press ↓ to advance to:

### *Factory Calibration - Screen 2*

<b>SERIAL ID</b>	<b>USER KEY</b>	<b>LCR RESET<sup>^</sup></b>
7200015		NO

#### **SERIAL ID**

The LCR printed circuit board serial number is shown here.

#### **USER KEY**

This is where the owner/office password is entered or viewed. When the system is locked, the operator will be prevented from changing field entries with the exception of **GROSS** and **NET PRESET, PRODUCT CODE, PRODUCT DESCRIPTION** and **NO-FLOW TIMER**. If the password is lost or forgotten, it can be recovered by the factory in this screen.

#### **LCR RESET**

This is a factory-entered value that will assist qualified personnel in clearing out memory problems, should they arise.

**NOTE:** A complete flow chart of the Lap Pad Menu structure appears in Appendix D.

---

# Recalibration/Proving without a Lap Pad

## SINGLE POINT RECALIBRATION/PROVING

The addition of two control buttons on the LCR allows for single point recalibration or proving without the need of a Lap Pad or other data entry device. This calibration is limited to recalculating the k-Factor or single point recalibration for up to four different product types. These two buttons can be used to select different display values as well as enter product selections and preset values. The **SELECT** button is the front and the **INCREASE** button is the rear as shown in the figure below.

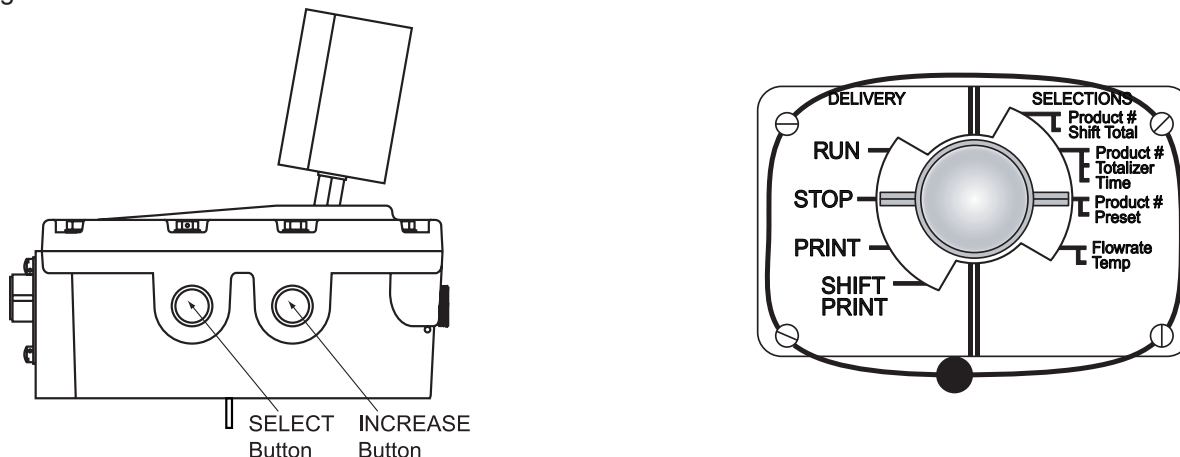

If a menu item can be edited, the **INCREASE** button will be active and can be used to increase a value or scroll through a list of options. The **SELECT** button will be used to scroll through consecutive digits across the display (from left to right).

### STEP 1: REMOVING THE LCR SWITCHPLATE FOR INITIAL SET-UP

- Remove the lead seal and wire assembly from the LCR Switchplate (if previously sealed by Weights & Measures authorities).
- Remove the four screws securing the nameplate over the red Selector Switch located on the front of the LCR and remove the plate.
- Rotate the Selector Switch counter-clockwise to the 6 o'clock (CALIBRATION/PROVER) position to permit access to the LCR calibration menu.

### STEP 2: CALIBRATION/PROVER Position

When the switch is rotated to the **CALIBRATION/PROVER** Position, the initial display is **Prover Quantity**.

Calibration - Screen 1, Prover Quantity

000.000

The units of measure are specified on the face label of the LCR. If a delivery is NOT active, press **INCREASE** to start a new delivery. If a delivery is active, press **INCREASE** to stop the delivery and advance to **Calibration - Screen 5, Editable Prover Quantity** (described on Page 31).

# Recalibration/Proving without a Lap Pad

---

## SINGLE POINT RECALIBRATION/PROVING CONTINUED

Press **SELECT** to advance to:

Calibration - Screen 1, Product Number

*Prod 1*

The current active **Product Number** is displayed. If a delivery is not active, the digit will be flashing, indicating that it can be changed. Press **INCREASE** to scroll through the options. These options are labeled **Prod 1**, **Prod 2**, **Prod 3**, and **Prod 4**. When the desired option has been chosen, press **SELECT**. This will advance the display to **Calibration - Screen 3, Flow Rate**.

**NOTE:** If the display is NOT flashing, it cannot be changed. Press **INCREASE** to stop delivery and advance to **Calibration - Screen 5, Editable Prover Quantity**.

Calibration - Screen 3, Flow Rate

*F 70.0*

This displays the current flow rate through the meter. The display will update every ½ second. The unit of measure is not displayed on the LCD, but appears directly below the display on the face of the LCR. This screen is **DISPLAY ONLY**. If a delivery is active, press **INCREASE** to stop delivery and advance to **Calibration - Screen 5, Editable Prover Quantity**.

Press **SELECT** to advance to:

Calibration - Screen 4, Temperature

*23.8 °F*

This display shows the current temperature of fluid moving through the meter. Values will be shown in degrees Celsius or Fahrenheit. The display updates every ½ second. **DISPLAY ONLY**. If a delivery is active, press **INCREASE** to stop delivery and advance to **Calibration - Screen 5, Editable Prover Quantity**.

Press **SELECT** to return to **Calibration - Screen 1, Prover Quantity**.

Calibration - Screen 5, Editable Prover Quantity

*101.323*

The **Prover Quantity** is displayed with the most significant digit flashing. The most significant digit appears in the left most position of the display. If the two most significant digits are **98** or **99**, a leading **0** will be displayed. To change the value of this digit, press **INCREASE**. Each time **INCREASE** is pressed, the digit increases by a value of **1**. Once the number **9** has been reached, pressing **INCREASE** again will roll the digit back to **0**. Once the desired number is chosen, press **SELECT** to move one digit to the right.



# Recalibration/Proving without a Lap Pad

## SINGLE POINT RECALIBRATION/PROVING CONTINUED

Repeat the process above for each digit position until the value for each has been selected. When the least significant digit is entered, the k-Factor is recalculated and the display returns to **Calibration - Screen 1**.

101.663

**NOTE:** If the new value entered is out of range for the LCR, "Error" will appear in the display. If this occurs, press **SELECT** to return to the Prover Quantity display. Repeat the process by beginning a new prover run.

When this process is complete, turn the Selector Switch clockwise out of the **Calibration Position** and replace the Switch plate.

**NOTE:** Step-by-step instructions on conducting a recalibration/proving run appear in Appendix E.

## CALIBRATION MENU

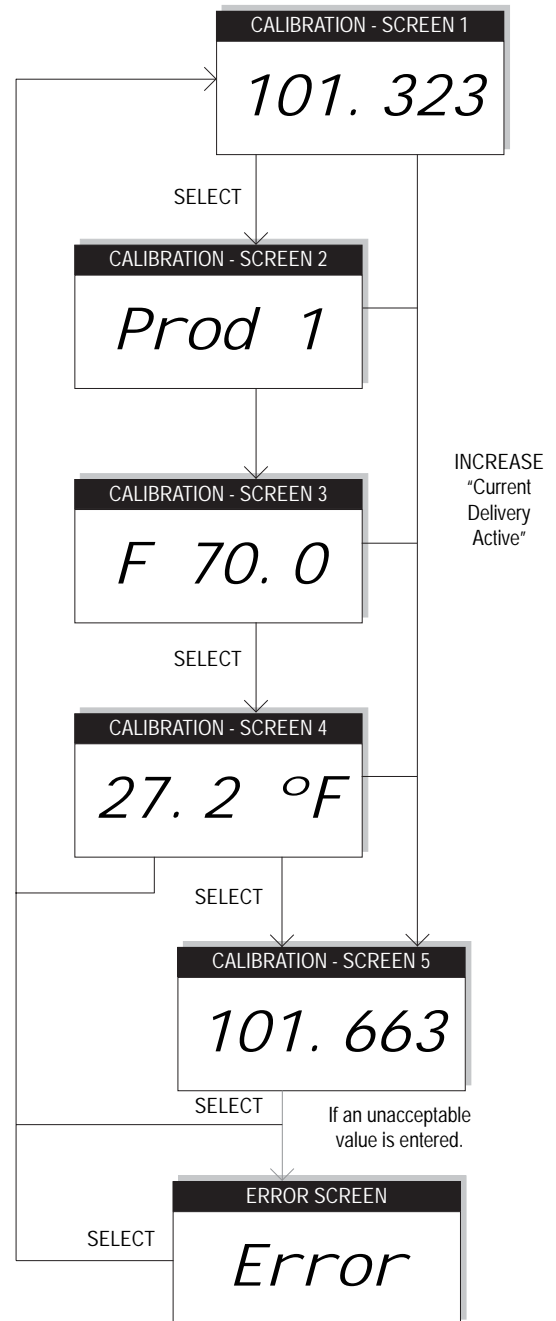

# Basic Operation without a Lap Pad

## DELIVERY & SELECTIONS MENU

Once the LCR has been calibrated, a Lap Pad is not required for daily use of the register. There are two push buttons located on the LCR. These can be used to select different display values as well as enter product selections and preset values. **SELECT** is the front button and the **INCREASE** is the rear button.

Values displayed or entered depend on the position of the red Selector Switch. The switch plate is divided into two categories, **DELIVERY** and **SELECTIONS**. When the Selector Switch is set to **RUN** on the **DELIVERY** side, it is set to **Flowrate/Temp** on the **SELECTIONS** side. By pressing the **SELECT** button, the menu on the **SELECTIONS** side is accessed.

NOTE: Although unlabeled, each switch position displays the delivery total as its first display option.

If a menu item can be edited, the **INCREASE** button will be active and can be used to increase a value or select an item from a list of options. The **SELECT** button will be used to advance to the next display or scroll through consecutive digits across the display (from left to right).

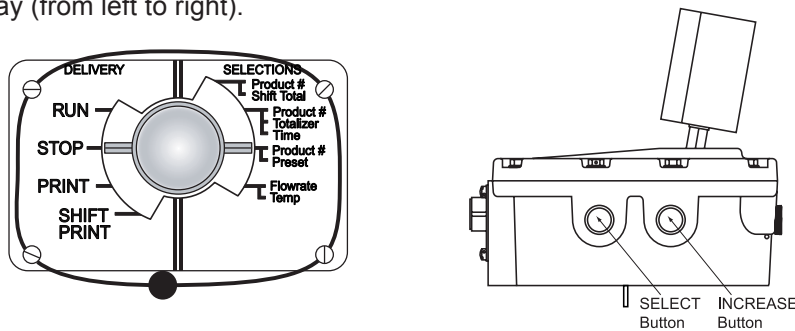

The LCR display characters are seven segments. An all segments display appears as follows:

### All Segments Display



### RUN Position (Flowrate/Temp.)

A typical delivery is initiated by moving the Selector Switch to the **RUN** position. The LCR will perform a series of diagnostics tests, reset the counter and activate the valve control output(s), opening the security valve. The control output will remain active until the Selector Switch is moved to the **STOP** or **PRINT** position, the **NO-FLOW TIMER** "times out", or a preset delivery volume is reached. A minimum amount of product flow must be detected (1 gallon or 5 litres) before the **NO-FLOW TIMER** starts counting. **Delivery Total** is the initial display.

### Delivery Total Display

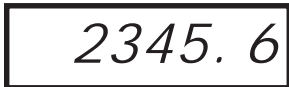

This display reflects the total for the current delivery. The display updates every 15.625 ms.

Press **SELECT** once to display **Flowrate**.

### Flowrate Display

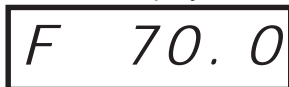

This displays the current flow rate through the meter. The display will update every 1/2 second. The unit of measure appears directly below the display on the face of the LCR. After 5 seconds the display will return to **Delivery Total**. This screen is DISPLAY ONLY.

## DELIVERY & SELECTIONS MENU CONTINUED RUN Position (Flowrate/Temp.) Continued

Press **SELECT** a second time (within 5 seconds) to display **Temperature**.

Temperature Display



23.8 °F

This display shows the current temperature of fluid moving through the meter. Values will be shown in degrees Celsius or Fahrenheit, depending on the initial set-up selection. The display updates every ½ second. After 5 seconds, the display will return to **Delivery Total**. This screen is DISPLAY ONLY.

Pressing **SELECT** a third time will return the display to **Delivery Total**. The **INCREASE** button has no function in the **RUN** position.

## STOP Position (Product #/Preset)

The **STOP** Position will cause the valve control output to close the security valve. This provides a means to pause the delivery. The valve will remain closed until the switch is returned to the **RUN** position. If the switch is returned to the **RUN** position and a ticket has not been printed, the amount for the delivery will **NOT** be reset. The counter will continue to display the accumulated total. If a **NO-FLOW TIMER** timeout is reached, the ticket will be printed, ending this delivery cycle. **Delivery Total** is the initial display. The display will update every 15.625 ms.

Press **SELECT** to advance to **Product Number**.



Prod 1

The current active **Product Number** is displayed. If a delivery is not active, the digit will be flashing, indicating that it can be changed. If the display is NOT flashing, it cannot be changed. Press **INCREASE** to scroll through the options. These options are **Prod 1**, **Prod 2**, **Prod 3**, or **Prod 4**, depending on the number of products programmed during calibration. When the desired option has been chosen, press **SELECT**.

The display will advance to **Preset**.



00000.0

The preset amount is displayed with the most significant digit flashing. This will be the digit to the far left of the display. To change the value of this digit, press **INCREASE**. Each time **INCREASE** is pressed, the digit increases by a value of 1. Once the number 9 has been reached, pressing **INCREASE** again will roll the digit back to 0. Once the desired number is chosen, press **SELECT** to move one digit to the right.



00200.0

Repeat the steps above to change the value of each digit. Press **SELECT** to advance through the digits of the display until the desired value is reached.



00200.0

Once the final digit is entered, press **SELECT** to return to the **Delivery Total**. Or, if the preset number is as desired, switch to **RUN** to begin delivery.

# Basic Operation without a Lap Pad

---

## DELIVERY & SELECTIONS MENU CONTINUED

### PRINT Position (Product #/Totalizer)

Turning the Selector Switch to the **PRINT** Position will cause the valve control outputs to turn off, closing the security valve. A ticket will be printed. Once the **PRINT** position has been entered, the delivery cannot be resumed. If tickets are required, the system will NOT allow another delivery to begin until the current ticket is printed. Once the ticket is printed, another delivery will be permitted when the Selector Switch is turned to the **RUN** position. **Delivery Total** is the initial display. The display will update every 15.625 ms.

Press **SELECT** to advance the display to **Product Number**:

Prod 1

The current active **Product Number** is displayed. If a delivery is not active, the digit will be flashing, indicating that it can be changed. If the display is NOT flashing, it cannot be changed. Press **INCREASE** to scroll through the options. These options are **Prod 1**, **Prod 2**, **Prod 3**, or **Prod 4**, depending on the number of products programmed during calibration. When the desired option has been chosen, press **SELECT**.

The display will advance to:

H12345

This displays the five most significant digits of the **GROSS** or **NET** grand totalizer. Press **INCREASE** to return to the **Product Number** display. Press **SELECT** to advance to:

L6789.0

This displays the five least significant digits of the **GROSS** or **NET** grand totalizer. The grand totalizer is a combination of these two displays. The total in this example is "123,456,789.0" units. Press **INCREASE** to return to the previous totalizer display. Press **SELECT** to advance to **Time of Day**:

11:44:00

If the unit is locked (set by the Lap Pad), a password needs to be entered to change the **Time of Day**. If the unit is unlocked, pressing **INCREASE** will cause the first digit on the left of the display to begin flashing on and off. Use **INCREASE** to adjust each digit of the time. The time is entered in military format, with 14:00:00 indicating 2:00 PM. When the final digit is programmed, press **SELECT** to return to **Delivery Total**. If a password is required, the next screen on Page 36 will be displayed (by pressing **INCREASE**) before the time can be changed.

P00000

Beginning with the digit to the immediate right of "P", use **INCREASE** to adjust it from **0-9**. Once this digit is selected, press **SELECT** to move one digit to the right. Once the complete, correct password has been entered, pressing **SELECT** will allow for the adjustment of the **Time of Day**.

**NOTE:** If the unit is password protected as programmed by the Lap Pad, the password must be numeric only, and contain exactly 5 digits.

---

# Basic Operation without a Lap Pad

## DELIVERY & SELECTIONS MENU CONTINUED PRINT Position (Product #/Totalizer) Continued

A shift ticket is printed when the Selector Switch is placed in the **SHIFT PRINT** Position for more than 2 seconds and a printer is loaded with paper and available to print the ticket. (NOTE: If the Selector Switch is turned to **SHIFT PRINT** and then out of **SHIFT PRINT** in less than 2 seconds, a Diagnostic/Calibration Information ticket is printed). **Delivery Total** is the initial display. The display will update every 15.625 ms.

Press **SELECT** to advance to **Product Number Display**:

*Prod 1*

The current active **Product Number** is displayed. If a delivery is not active, the digit will be flashing, indicating that it can be changed. If the display is NOT flashing, it cannot be changed. Press **INCREASE** to scroll through the options. These options are **Prod 1**, **Prod 2**, **Prod 3**, or **Prod 4**, depending on the number of products programmed during calibration. When the desired option has been chosen, press **SELECT**.

The display will advance to:

*H 1 2 3 4 5*

This displays the five most significant digits of the **GROSS** or **NET Shift** totalizer. Press **INCREASE** to return to the Product Number display. Press **SELECT** to advance to:

*L 6 7 8 9 . 0*

This displays the five least significant digits of the **GROSS** or **NET Shift** totalizer. The shift totalizer is a combination of these two screens. The total in this example is "543,216,789.0" units. Press **INCREASE** to return to the previous totalizer display. Press **SELECT** to return to **Delivery Total**.

---

## Printing Diagnostic/Calibration Tickets

If a delivery was terminated due to a pulser failure, temperature probe failure or other fault, the last line on the delivery ticket will read, "\*\***FAULT: PRINT DIAGNOSTICS TICKET\***".

A Diagnostic Ticket is printed when the Selector Switch is turned to the **SHIFT PRINT** Position for less than two seconds. This ticket contains the same information found on the calibration ticket that prints when the Calibration Mode is exited, but does not increment the calibration number or require a Weights & Measures seal to be broken.

This allows the operator to spot check the calibration of the register and/or diagnose problems with the unit. The ticket will show any problems on the last line to assist in troubleshooting the problem.

# LCR Menu Flow Charts

## Selector Switch

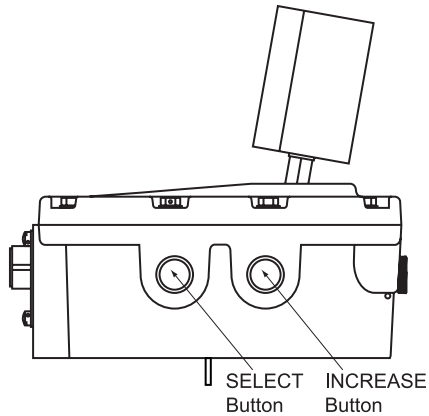
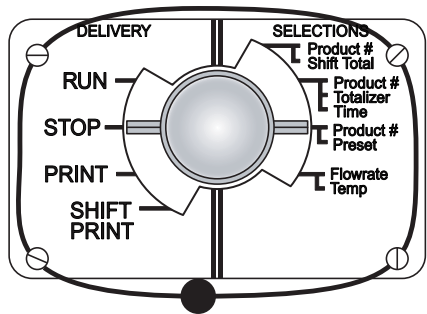

## RUN Position of Selector Switch

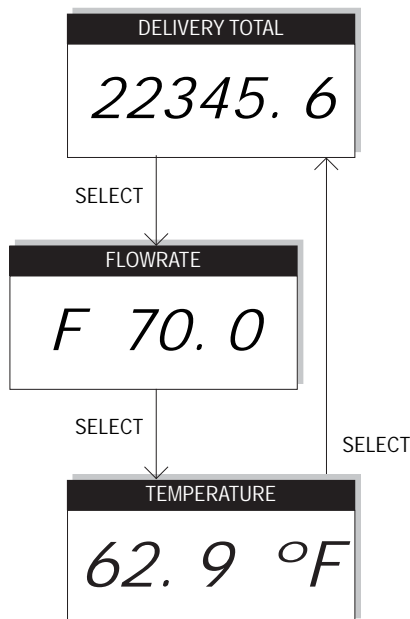

## STOP Position of Selector Switch

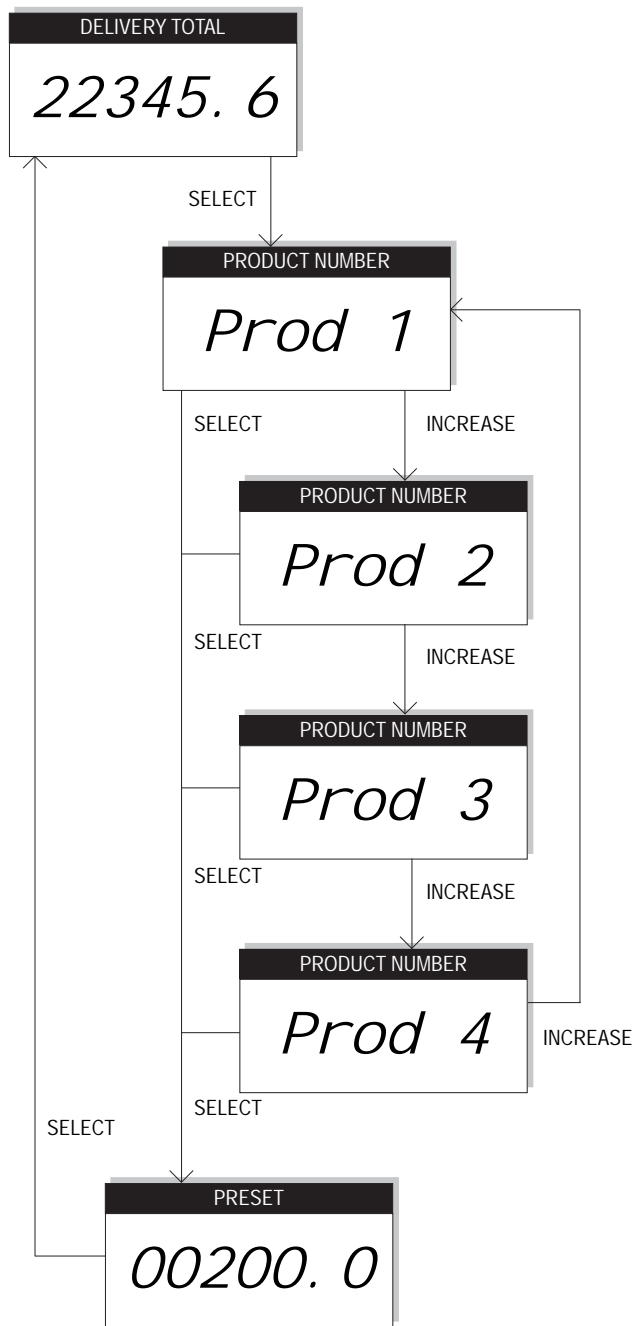

SELECT: Step through digits.  
INCREASE: Increment each position 0-9.

# LCR Menu Flow Charts

**PRINT Position of Selector Switch**

**SHIFT Position of Selector Switch**

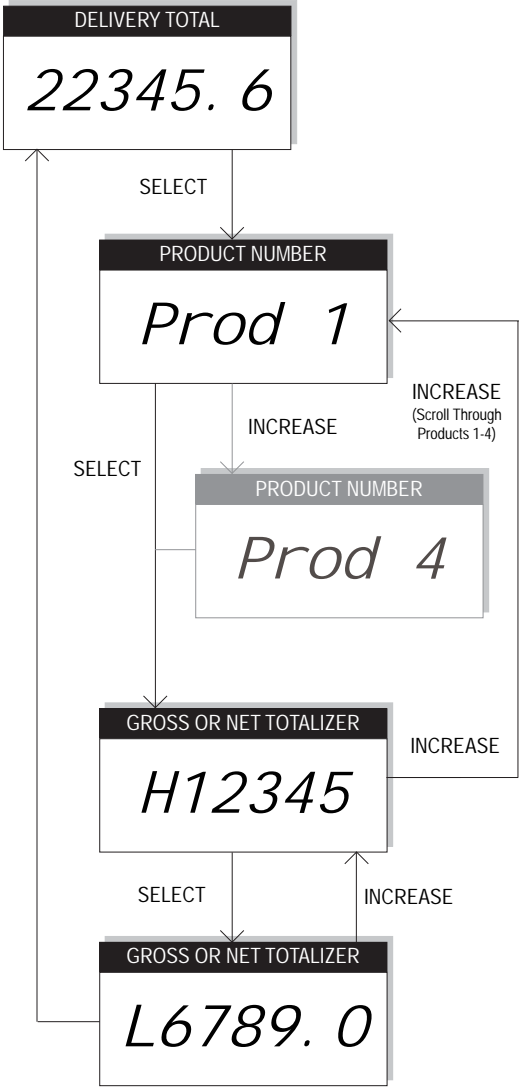
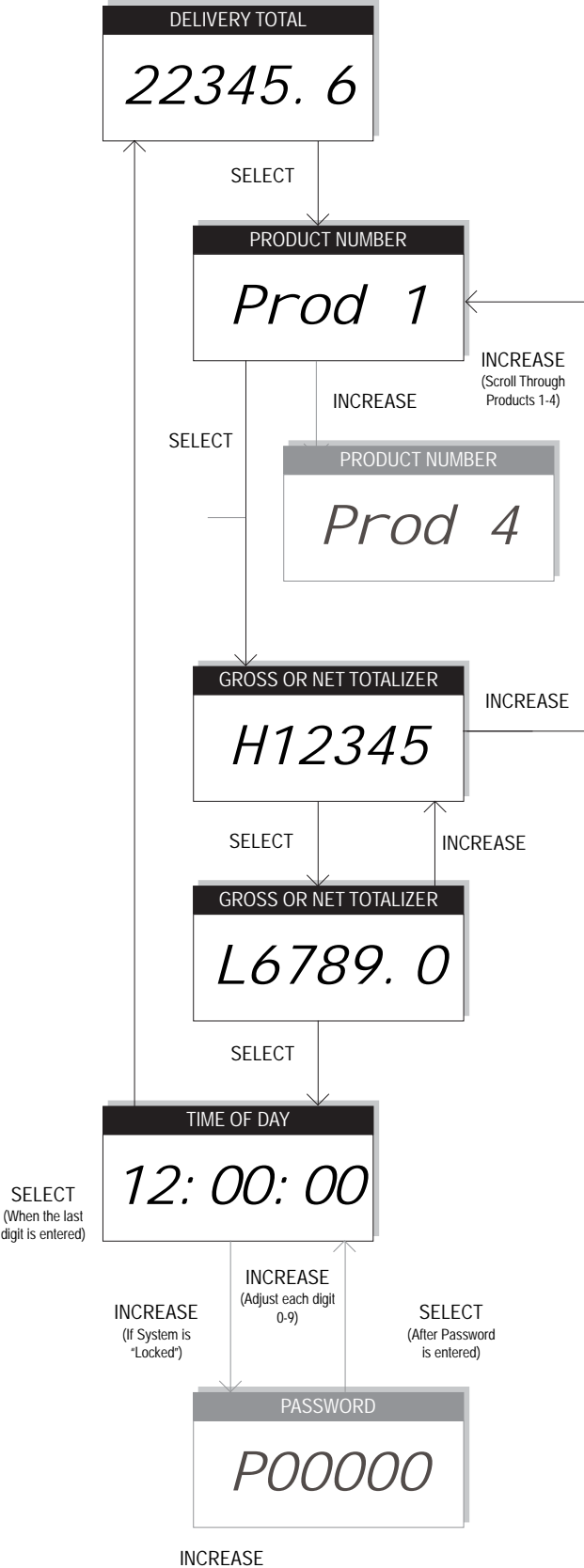

# LCR Troubleshooting Guide

---

To comply with Weights & Measures requirements, it is necessary to start and stop each delivery with a fully packed hose. Normally, this will be the case. However, there are times where the hose is not fully packed (e. g. after a preset delivery). As such, the hose must be packed and the register zeroed prior to making the next delivery.

**NOTE:** This procedure will not work for an empty or dry hose. If more than 1 gallon or 5 litres of liquid is required to pack the hose, a delivery ticket must be printed.

To pack the hose at the start of a delivery:

1. Turn the Selector Switch to RUN. **DO NOT OPEN THE HOSE NOZZLE.** The display will reset and the solenoid will open the valve, packing the hose.
2. When the display has stopped incrementing, the hose is packed.
3. Then the Selector Switch to STOP. This will de-energize the solenoid and close the valve.
4. Turn the Selector Switch back to RUN. The display will reset to zero, and the solenoid will energize again and open the valve.
5. Open the hose nozzle and begin the delivery.
6. The Selector Switch can only be turned to STOP one time per delivery, at the start of the delivery, to pack the hose.
7. To end a delivery with a packed hose, complete the delivery by closing the hose nozzle prior to turning the Selector Switch to STOP. If making a preset delivery where the solenoid closes the valve prior to the hose nozzle being closed, the above noted procedure to pack the hose must be conducted on the next delivery

## LCR Troubleshooting Guide

The LCR troubleshooting guide covers most common problem situations. Call your local Liquid Controls Service Center or the Liquid Controls Electronic Customer Service department for any problems that are not covered in this guide.

<b>NOTICE</b>	<b>! DANGER</b>
It may be necessary to break Weights & Measure seals to perform certain troubleshooting steps in this guide. Contact your local supervisor or local Weights & Measures authorities for information before breaking any seals.	Serious Injury or Death may Result - Fire, Explosion and Electrical Shock Hazard.  Only trained and authorized personnel should perform troubleshooting. Use extreme caution when troubleshooting and taking all electrical measurements. Be sure that equipment is in a well ventilated area and that hazardous or flammable vapors are not and will not be present during testing. If equipment is located in a hazardous environment, it may be necessary to remove the equipment and perform troubleshooting in a safe area



# LCR Troubleshooting Guide

**NOTE:** Check for proper operating voltages before changing the circuit board. If the circuit board needs to be changed, be sure to remove all power to the LCR.

5. If an error occurs during a delivery, the message "**\*\* FAULT: PRINT DIAGNOSTICS TICKET\*\***" will appear on the delivery ticket. The diagnostic ticket will contain an error message that can be useful in troubleshooting. **Print a diagnostic ticket** by moving the red Selector Switch to "**SHIFT PRINT**" for less than two seconds. Examine the diagnostic ticket to make sure all set-up fields are accurate, e.g. pulses per unit volume, temperature coefficient and base temperature.
6. NEVER remove a terminal block or jumper with the power on.
7. NEVER install a terminal block or jumper with the power on.
8. NEVER force a terminal block into its location.
9. NEVER exchange or reposition terminal blocks on the circuit board.
10. In case of a major problem such as a burned or water-damaged circuit board, evaluate possible causes before replacing it and turning the power back on.
11. Isolate the problem before changing the circuit board.
12. Return faulty circuit boards with the proper forms, concisely completed.

There may be several probable causes for a system malfunction. Listed on the next four pages are several probable causes to aid in returning the system to operation as quickly as possible. The list is not all-inclusive and should only be used as a guide.

PROBLEM	PROBABLE CAUSE	SOLUTION
Unit will not power up or there is no display.	Inadequate supply voltage. +9 to 28VDC is required for operation.	<ol style="list-style-type: none"> <li>1. With the key in the accessory position, check the battery voltage to the circuit board at J6. Use terminal #11 as positive and terminal #12 as DC ground. While the LCR will power-up at +9VDC, it is recommended that the input be at least +12.6VDC. Ref</li> <li>2. Check the 7.5A, in-line fuse (Part # 70985) for continuity. It is located in the accessory power line. Replace if necessary.</li> </ol>
Unit blows 7.5A fuse.	+12VDC Battery line is shorted to ground	<ol style="list-style-type: none"> <li>1. For safety reasons, remove the 7.5A, in-line fuse from the accessory power cable.</li> <li>2. Remove the 3-pin power connector J6. Inspect for stray wire stands and visible shorts.</li> <li>3. Inspect the full length of the power cable. Look for damaged insulation, which may cause shorting between the cable and ground potential (e. g. truck frame or chassis). If the power cable (Part # 81512) is damaged, it must be replaced.</li> <li>4. Replace the 7.5A fuse (Part # 70985) and re-install the J6 connector.</li> <li>5. If the 7.5A fuse blows again, replace the LCR circuit board.</li> <li>6. If the 7.5A blows after the LCR circuit board has been replaced, then replace the power cable (Part # 81512).</li> </ol>

# LCR Troubleshooting Guide

PROBLEM	PROBABLE CAUSE	SOLUTION									
"Power Failure" appears on Lap Pad or diagnostic ticket.	Power to LCR interrupted during delivery.  Static discharge.	<ol style="list-style-type: none"> <li>1. Check accessory power cable for damage. Ensure that the power, common and ground wires (11, 12 and 13) on power connector J6 are secure. J6 is located on the rear of the circuit board.</li> <li>2. Turn on all truck accessories (headlamps, 2-way radio, heater, etc.). Engage the hose reel and monitor the DV voltage at J6 using terminal #11 as positive and terminal #12 as ground. If the voltage drops below +10VDC, the truck electrical system may not</li> <li>3. Verify proper grounding of the LCR. Refer to the LCR Installation Manual for proper grounding procedures.</li> </ol>									
Epson printer release light flashes	Low voltage to the Epson printer.	<ol style="list-style-type: none"> <li>1. Check the battery voltage for a minimum of +12.6VDC.</li> <li>2. Under extreme cold conditions, the printer may not operate. Warm up the cab of the vehicle.</li> <li>3. If the release light continues to flash, replace the Epson 295 Printer (Part # E49001).</li> </ol>									
No power indicator lights to the Epson printer.	No power to the Epson printer.	<ol style="list-style-type: none"> <li>1. Verify that the power switch is in the ON position. This switch is located on the left-hand side of the Epson 295 printer.</li> <li>2. Check the printer power cable (part # 825001) to ensure that it is seated properly. If the problem persists, replace the power cable followed by the Epson printer (Part # E49001).</li> </ol>									
"Temperature Error" appears on diagnostic ticket or on the Lap Pad.	Open or shorted circuit between the RTD probe and LCR.	<ol style="list-style-type: none"> <li>1. Check the RTD Probe and terminal block for continuity.</li> <li>2. Remove terminal block J14 from the circuit board. On the terminal block, measure and record the resistance between the following pins:   <table border="0"> <tr> <td><u>PIN #</u></td> <td><u>PIN#</u></td> <td><u>READING</u></td> </tr> <tr> <td>21</td> <td>to 22</td> <td>100 ? ± 20?</td> </tr> <tr> <td>20</td> <td>to 23</td> <td>100? ±20?</td> </tr> </table> </li> <li>3. If the readings are not within the above tolerances, replace the RTD probe (Part # 71130).</li> </ol>	<u>PIN #</u>	<u>PIN#</u>	<u>READING</u>	21	to 22	100 ? ± 20?	20	to 23	100? ±20?
<u>PIN #</u>	<u>PIN#</u>	<u>READING</u>									
21	to 22	100 ? ± 20?									
20	to 23	100? ±20?									

# LCR Troubleshooting Guide

PROBLEM	PROBABLE CAUSE	SOLUTION
Product flow does not register on Lap Pad or LCR display	Pulser shaft is not turning with product flow. Pulser failure.	<ol style="list-style-type: none"> <li>1. Manually spin the pulser shaft and monitor the LCR display.</li> <li>2. If the LCR display counter increments, this may indicate a mechanical problem. Contact your local Liquid Controls Service Center or the Liquid Controls Service Department for assistance.</li> <li>3. If the LCR display counter does not increment, see Pulser Failure.</li> </ol>
“Pulser Failure” appears on the diagnostic ticket or on the Lap Pad display.	<p>Missing pulse counts. Excessive reversals.</p> <p>NOTE: Pulser faults generally occur in a high vibration environment. Liquid Controls is not responsible for pulser failures caused by excessive system vibrations.</p>	<ol style="list-style-type: none"> <li>1. Check the pulser output.</li> <li>2. Open the LCR cover by loosening the single screw that holds the cover closed. Using a reliable multimeter, measure the following DC voltages on terminal block J8, while J8 is connected to the circuit board. Use terminal #37 as ground reference. <u>TERMINAL # VOLTAGE</u> J8 #32 +5 VDC J8 #33 0 or +5VDC J8 #34 0 or +5VDC</li> <li>3. If the following voltages are observed, check for loose pulser wiring connections. If no loose connections are found, replace the encoder harness. (Part # 81584 – for Series E2611X and E2612X) (Part # 81412 – for Series E2605X and E2606X) or (Hard wires for POD pulser.) <u>TERMINAL # VOLTAGE</u> J8 #32 0 VDC J8 #33 +1-3VDC J8 #34 +1-3VDC</li> <li>4. Insert a ticket into the Epson printer. Begin a delivery. With product flowing through the meter, measure the following DC voltages on the terminal block. <u>TERMINAL # VOLTAGE</u> J8 #32 0 VDC J8 #33 +1-3VDC J8 #34 +1-3VDC</li> <li>5. If the voltages shown below are observed, ensure that the pulser shaft is rotating. Look for any mechanical problems that may cause either the meter or the pulser shaft to lock up. If the Lap Pad continues to indicate a pulser failure, replace the pulser. (Part # 81582 for Series E2611X and E2612X) (Part # 81170 for Series E2605X and E2606X) or (Part # 81159 for POD pulser) <u>TERMINAL # VOLTAGE</u> J8 #32 +5 VDC J8 #33 0 or +5VDC J8 #34 0 or +5VDC</li> </ol>

# LCR Troubleshooting Guide

PROBLEM	PROBABLE CAUSE	SOLUTION
Valve will not open.	<p>Solenoids are inactive or inoperative.</p> <p>Foreign debris in system.</p>	<ol style="list-style-type: none"> <li>1. Insert a delivery ticket into the Epson printer and start a delivery.</li> <li>2. Move the selector switch from <b>RUN</b> to <b>STOP</b> and back to <b>RUN</b>. Listen for an audible clicking sound from the solenoids.</li> <li>3. If there is an audible click from the solenoid (but still no flow), this may be an indication of a mechanical problem with the main valve or its associated components. Contact your local Liquid Controls Service Center or the Liquid Controls Service Department.</li> <li>4. If there is NO audible click from the solenoid, check the voltage to Pin #s 14, 15, 16 and 17 of terminal block J13. While still in <b>RUN</b> mode, use a reliable multimeter to measure the following DC voltages on the circuit board. Use J8 pin #38 as a ground <ul style="list-style-type: none"> <li><u>TERMINAL # VOLTAGE</u></li> <li>J13 #14 12.0VDC ±1.5VDC</li> <li>J13 #15 1.0VDC ± 0.5VDC</li> <li>J13 #17 12.0VDC ±1.5VDC</li> <li>J13 #18 1.0VDC ±0.5VDC</li> </ul> </li> <li>5. If the above voltages are correct, this may be an indication of a problem with the valve or its associated components. Contact your local Liquid Controls Service Center or the Liquid Controls Service Department for assistance.</li> <li>6. If the above voltage are <b>NOT</b> correct, replace the following components with known working units until the problem is resolved: <ul style="list-style-type: none"> <li>Solenoids* Varies depending on system.</li> <li>LCR Circuit Board* Part # 81547-1 for series E3611X and E3612X</li> </ul> <p>*Contact your local Liquid Controls Service Center or the Liquid Controls Service Department for assistance.</p> </li> </ol>

## Appendix A - Compensation Types & Parameters

The table below shows the supported methods of calculating the **Volume Correction Factor (VCF)**. The method is independently selectable for each product in **Product Calibration**. The table below shows the valid temperature ranges for each table. The hold temperature,  $T_{hold}$ , is the temperature that VCF is held at for temperatures  $< T_{hold}$  and  $> T_{min}$ . This is done to allow compensation in very cold environments where further extrapolation of equations is not allowed.

Product	VCF Type	Parameter Coefficient	Range	Scale °C or °F	$T_{base}$	$T_{min}$	$T_{hold}$	$T_{max}$
General	Linear	Linear	0 to 0.003	°C	15	-90	N/A	+100
General	Linear	Linear	0 to 0.005	°F	60	-130	N/A	+212
LPG <i>USA</i>	API Table 24	Specific Gravity	0.5 to 0.550	°F	60	-50	-50	+140
LPG <i>Europe &amp; Canada</i>	API Table 54	Density kg/L	0.5 to 0.600	°C	15	-46	-46	+60
Refined Petroleum Products <i>Europe &amp; Canada</i>	API Table 54B	Density kg/m <sup>3</sup>	653.0 to 1075.0	°C	15	-50	-40	+95
Refined Petroleum Products <i>USA</i>	API Table 6B	API Gravity	0 to 85	°F	60	-50	-40	+200
General	API Table 54C	Coefficient	0.000486 to 0.001674	°C	15	-50	-40	+95
Lube Oil <i>Europe &amp; Canada</i>	API Table 54D	Density kg/m <sup>3</sup>	800 to 1164	°C	15	-50	-40	+95
Ammonia <i>Canada</i>	NH <sub>3</sub>	N/A	N/A	°C	15	-30	-30	+40

## Appendix B - Operation Using VT 100 Compatible Terminal

---

If the LCR is operated using a VT 100 compatible terminal (instead of the LC Lap Pad), refer to the following chart for the terminal keystrokes that correspond to the Lap Pad keystrokes. VT 100 communication parameters that must be observed include:

- Baud Rate (9600)
- Data Bits (8)
- Parity (None)
- Stop Bits (1)
- Flow Control (None).

Operation	Lap Pad Keystroke	PC Terminal Emulation
Return to Top Level Menu	M1	<control L>
Move to Next Menu Item	↓	<control D>
Move to Previous Menu Item	↑	<control U>
Select Item	ENTER	ENTER
Submit Data and Return	ENTER (after data entry)	ENTER (after data entry)
Move to Next Field	↓	<control D>
Move to Previous Field	↑	<control U>
Clear Field/Start Data Entry	Clear	Backspace
Start	Start	<control B>
Stop	Stop	<control S>
Print	Print	<control P>
Move to Next Screen	M#	<control N>

---

## Appendix C - Error Messages

The LCR was designed to perform diagnostic analysis of problems as they occur. If an error should occur, one of the following messages may be displayed on the Lap Pad or printed on a Diagnostic Ticket (see troubleshooting section). The list below explains the error message and any possible corrective action. The LCR was designed to handle most foreseeable problems on its own. Consequently, if the suggestions listed are not successful, the assistance of a trained authorized Liquid Controls service provider is recommended.

### RUN TIME MESSAGE LIST

*These messages may be displayed on the Lap Pad if an error occurs while the system is running.*

#### **FLASH CRC FAILURE**

The CRC stored with an LCR data block indicates the data or CRC has been corrupted. A "**REBUILD**" operation could possibly fix the problem. If not, try "**CLEAR ALL**". If that does not work, hardware may be the problem and the unit should be returned to Liquid Controls for more analysis. **NOTE:** Before performing a "**CLEAR ALL**" operation, print a calibration ticket.

#### **FLASH WRITE FAILURE**

A failure was detected while a data block was being written to the flash memory. See the resolution suggestion under **FLASH CTC FAILURE**.

#### **FLASH NOT INITIALIZED**

This error indicates that a "**CLEAR ALL**" or "**REBUILD**" has been attempted without the Selector Switch in **CALIBRATION** position.

#### **RANGE ERROR**

The data entered is not within the legal range limits for the field being changed.

#### **DUPLICATE FLOW RATE ERROR**

This message only appears when setting up multi-point calibration. When calibrating a multi-point meter, the linearization points must all have unique flow rates. This message is displayed when a flow rate being entered is already used on another point.

#### **ADJACENT POINTS OUT OF 0.25% RANGE**

This message only appears when setting up multi-point calibration. When calibrating a multi-point meter, adjacent linearization points must be within a 0.25% correction of each other. To avoid this error, select an additional flow rate and correction factor between the two points. More than one additional point may be required. Adjacent flow rates entered for linearization cannot have their percent error fields further than 0.25% apart.

#### **COUNTER TEST IN PROGRESS...**

A delivery has been started and the counter test is in progress. When the test is complete, flow will start. This is not an error condition.

#### **START ENABLED - SWITCH TO RUN TO BEGIN DELIVERY**

The **START** button on the Lap Pad was pressed but the Selector Switch was not in the **RUN** position. When the switch is put in the **RUN** position, the delivery will begin.

# Appendix C - Error Messages

---

## DIAGNOSTIC MESSAGE LIST

If an error occurs during a delivery, the message "**\*FAULT: PRINT DIAGNOSTICS TICKET\***" will appear on the delivery ticket. The appropriate message below is then printed on the diagnostic ticket if an error has occurred. A diagnostic ticket is printed by loading a ticket into the printer and then moving the Selector Switch to the **SHIFT PRINT** position for less than two seconds.

### PREVIOUS DELIVERY TICKET PENDING

A new delivery was attempted but the previous delivery ticket was not printed in its entirety. The **PRINT** button should be pressed on the Lap Pad, or the Selector Switch should be placed in the **PRINT** position. Once the previous delivery ticket is printed, a new delivery can begin.

### ROM CHECKSUM ERROR

This message indicates that the program memory space of the LCR has been corrupted. If this error occurs, the unit must be re-flashed with the control software before any deliveries can be made.

### TEMPERATURE ERROR

This message appears if the temperature circuit returns an error or if the temperature calibration data is in error. Check the temperature probe and its connections. A broken temperature probe wire is the most common cause of this error. See the troubleshooting section.

### VCF DOMAIN ERROR

This message indicates that the calculated temperature falls outside the allowable range for the current compensation parameter. Verify that the correct product compensation type (see **PRODUCT SET-UP**) is being used.

### PULSER FAILURE

This message appears if the number of pulser faults exceeds the allowable amount. The number of allowable faults is determined by an equation and cannot be changed. A maximum of 5 times the number of pulses required for the least significant displayed digit OR 0.1% of the pulses generated for the current delivery are allowed. Pulser faults generally occur in high vibration environments or when the flow rate is highly throttled. Liquid Controls is not responsible for pulser failures caused by excessive system vibrations. See the troubleshooting section.

### METER CALIB ERROR

A product that has not been calibrated has been selected for delivery. Select a valid calibrated product.

### PRESET STOP

This message appears if the delivery has stopped due to a **GROSS** or **NET PRESET** amount being reached. This is not an error condition.

### NO FLOW STOP ERROR

This message appears if the **NO-FLOW TIMER** has expired, causing the current delivery to be terminated. This is not an error condition. Entering "0" for this parameter in the **GENERAL SET-UP** menu can turn off the **NO-FLOW TIMER**, however, this results in a system that is less secure.

### STOP REQUESTED

This message appears when a **STOP** command has been sent to the LCR system to pause the delivery. **STOP** can be activated from the Selector Switch, Lap Pad, or a Terminal. This is not an error condition.



### DIAGNOSTIC MESSAGE LIST CONTINUED

#### DELIVERY END REQST

This message appears when a **PRINT** command has been sent to the LCR system to terminate a delivery. **PRINT** can be activated from the Selector Switch, Lap Pad, or Terminal. This is not an error condition.

#### POWER FAIL ERROR

This message appears when a delivery was ended due to a loss of input voltage. Check the power supply and wiring to the LCR. Check the in-line fuse. See the troubleshooting section.

#### PRESET ERROR

This message appears when a flash memory error is detected during a delivery when accessing any of the fields used by **PRESETS**. This includes **GROSS PRESET** amount, **NET PRESET** amount, **S1 CLOSE VALUE**, remaining **PRESET** amounts, the **PRESET** type, or **PRESET ALLOWED** fields.

#### TERMINAL NOT CONNECTED

This message appears when a Terminal or Lap Pad is disconnected during a delivery. Check the cables and connectors for broken wires and loose connections.

#### CHECK PRINTER AND CABLE

This message appears when the printer is not responding. This can be the result of a faulty data cable, power cable, or LCR circuit board failure. The most common cause is that a ticket is not in place in the printer. The Epson Slip printers have a built in photo eye to detect if a ticket is in position.

#### DATA ACCESS ERROR

This message appears when a flash memory error occurs.

#### DELIVERY TICKET PENDING

This message appears when a delivery has been terminated but a delivery ticket has not been completely printed. When this occurs, it is assumed that the delivery is still active. No fields can be changed until the delivery ticket has been entirely printed. Load a ticket into the printer and print the delivery ticket by moving the Selector Switch to **PRINT**, or by pressing **PRINT** on the Lap Pad.

#### SHIFT TICKET PENDING

This message appears when a shift ticket is being printed. This is not an error condition.

#### FLOW ACTIVE

This message appears when a delivery has been initiated. This is not an error condition.

#### DELIVERY ACTIVE

This message appears when a delivery has been initiated. This is not an error condition.

#### GROSS PRESET ACTIVE

This message appears when a **GROSS PRESET** is active. The **PRESET** type must be set to **GROSS** or **BOTH** and a desired amount entered in the **GROSS PRESET** field. This is not an error condition.

# Appendix C - Error Messages

---

## DIAGNOSTIC MESSAGE LIST CONTINUED

### NET PRESET ACTIVE

This message appears when a **NET PRESET** is active. The **PRESET** type must be set to **NET** or **BOTH** and a desired amount entered in the **NET PRESET** field. This is not an error condition.

### GROSS PRESET STOP

This message appears when the **GROSS PRESET** amount has been reached. This is not an error condition.

### NET PRESET STOP

This message appears when the **NET PRESET** amount has been reached. This is not an error condition.

### TVC ACTIVE

This message appears when **TEMPERATURE COMPENSATION** is active on the current product. This is not an error condition.

### S1 CLOSE REACHED

This message appears when the **S1 CLOSE** value has been reached during a **PRESET** delivery. This is not an error condition.

### INIT WARNING

This message appears when **NO-FLOW TIMER** or the ticket required fields return an error . If this happens, the delivery can continue but the default values of **180** and **YES** are used.

### END OF ERROR LIST

This message appears when the end of the error list has been reached. This is not an error condition.

# Appendix D - Lap Pad Menu Flow Charts

## GENERAL START UP

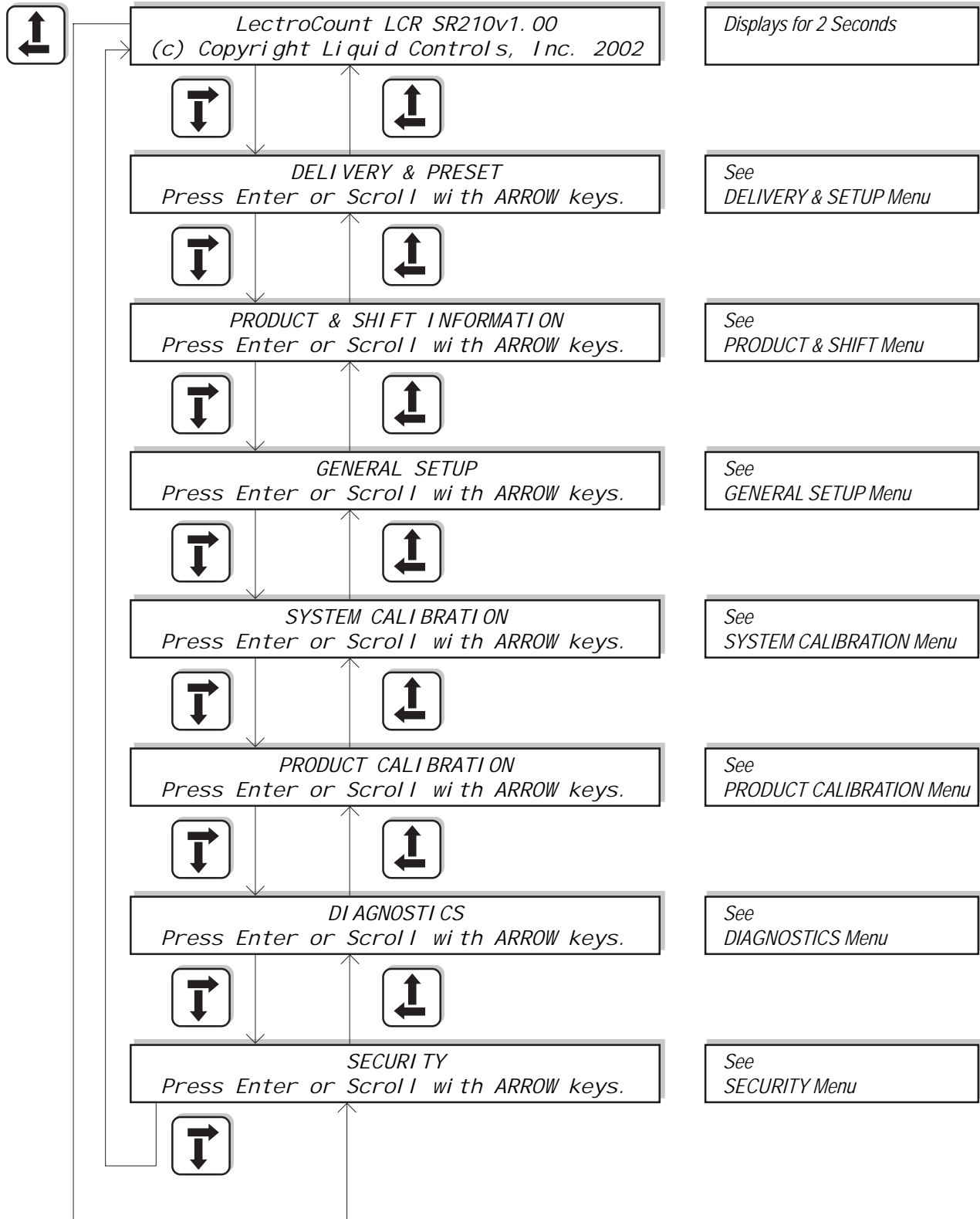

# Appendix D - Lap Pad Menu Flow Charts

## DELIVERY & PRESET MENU

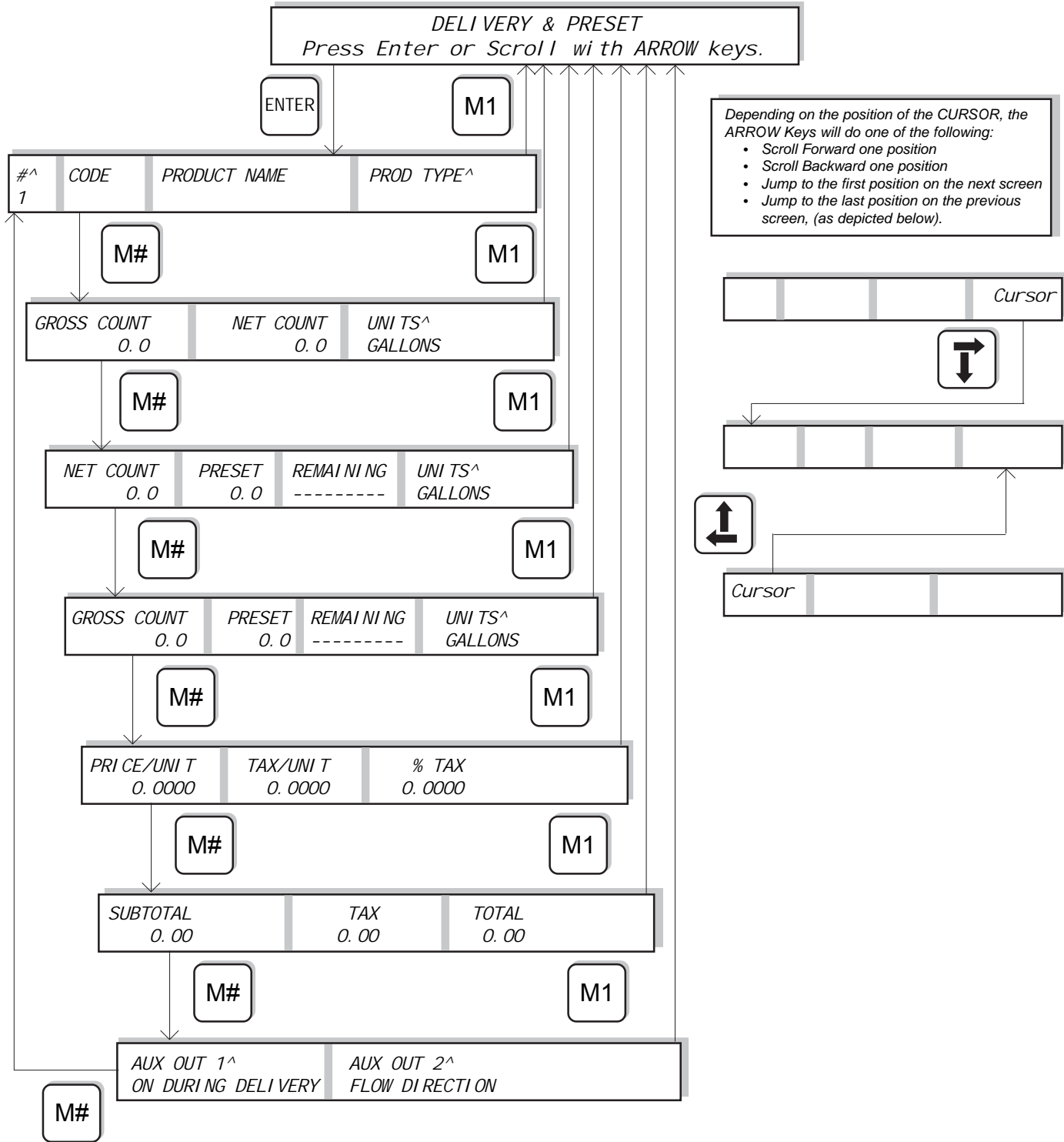

# Appendix D - Lap Pad Menu Flow Charts

## PRODUCT & SHIFT

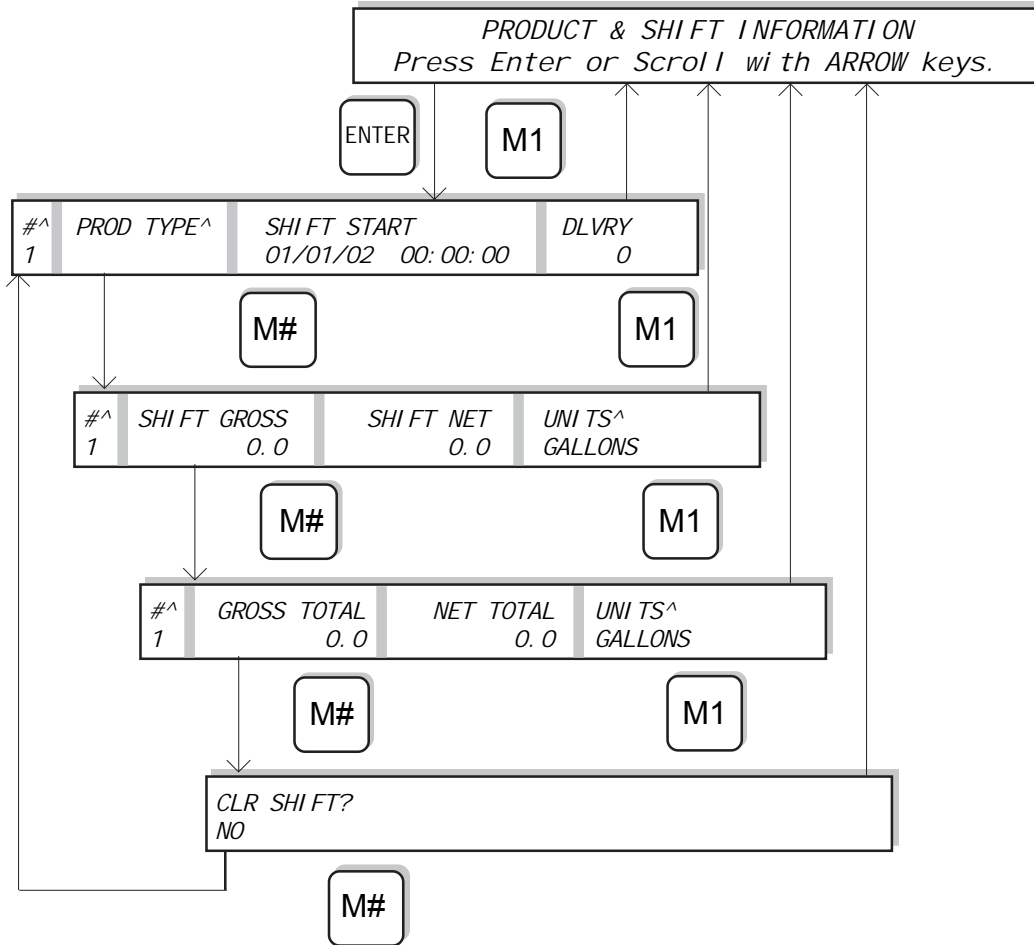

# Appendix D - Lap Pad Menu Flow Charts

## GENERAL SETUP

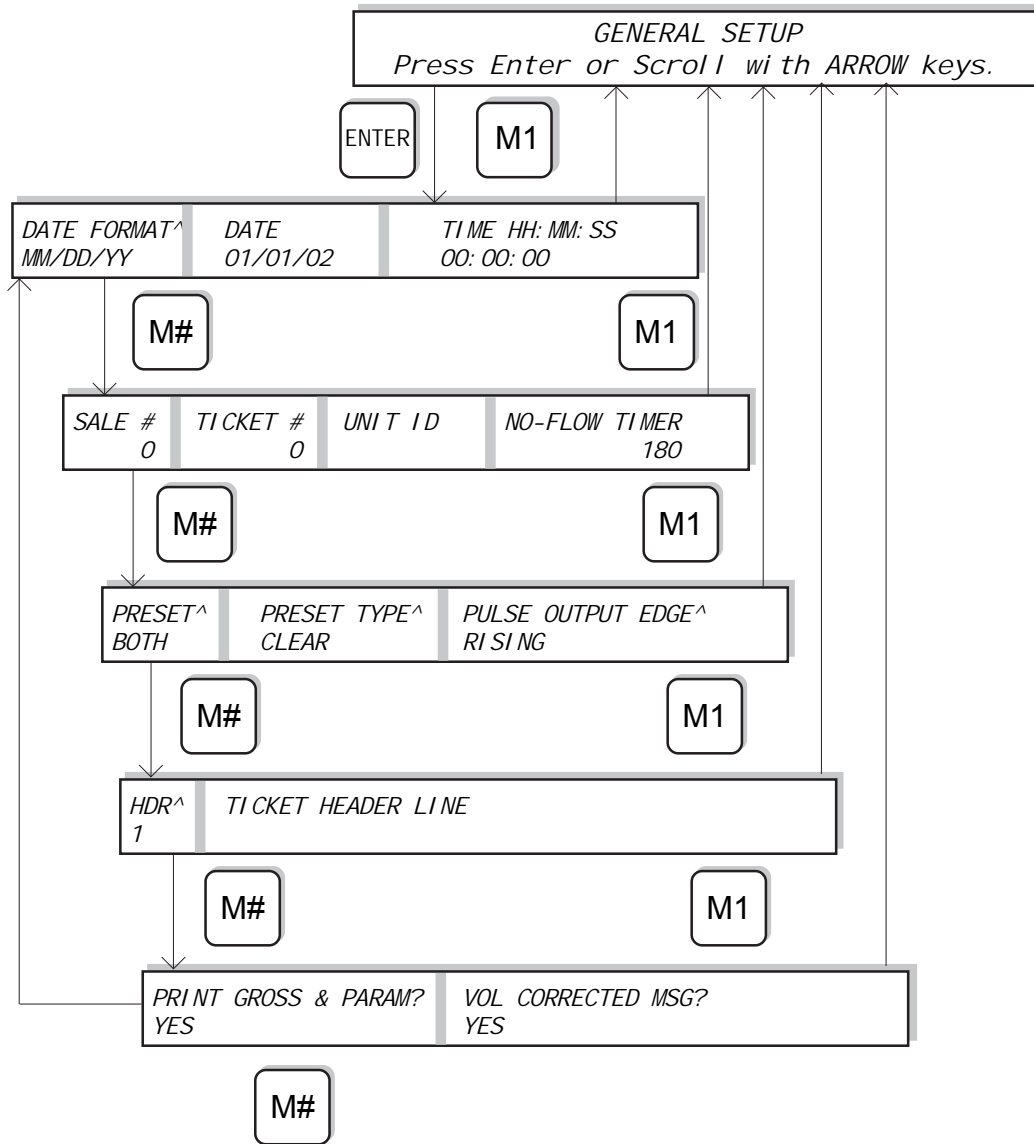

# Appendix D - Lap Pad Menu Flow Charts

## SYSTEM CALIBRATION

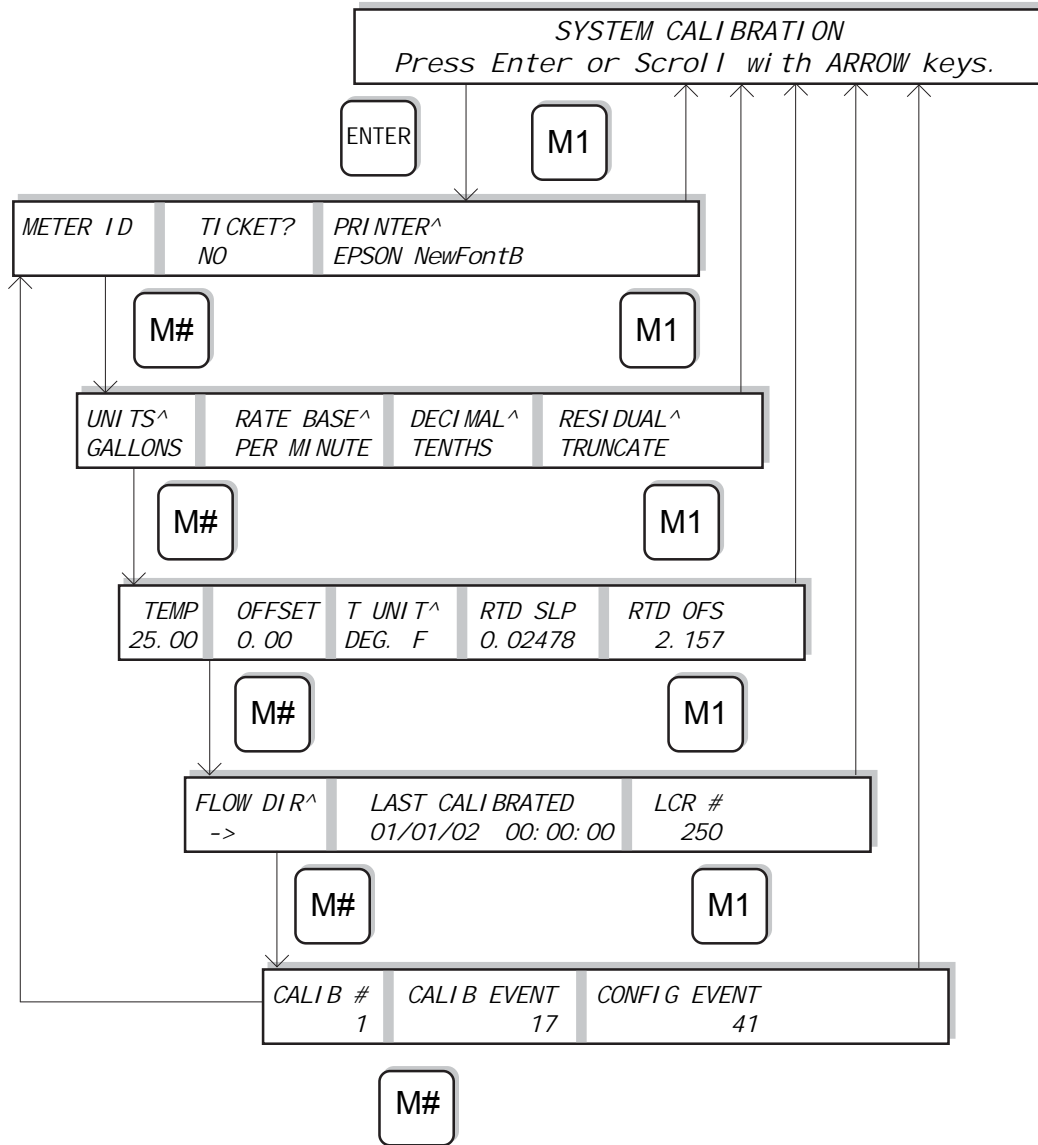

# Appendix D - Lap Pad Menu Flow Charts

## PRODUCT CALIBRATION

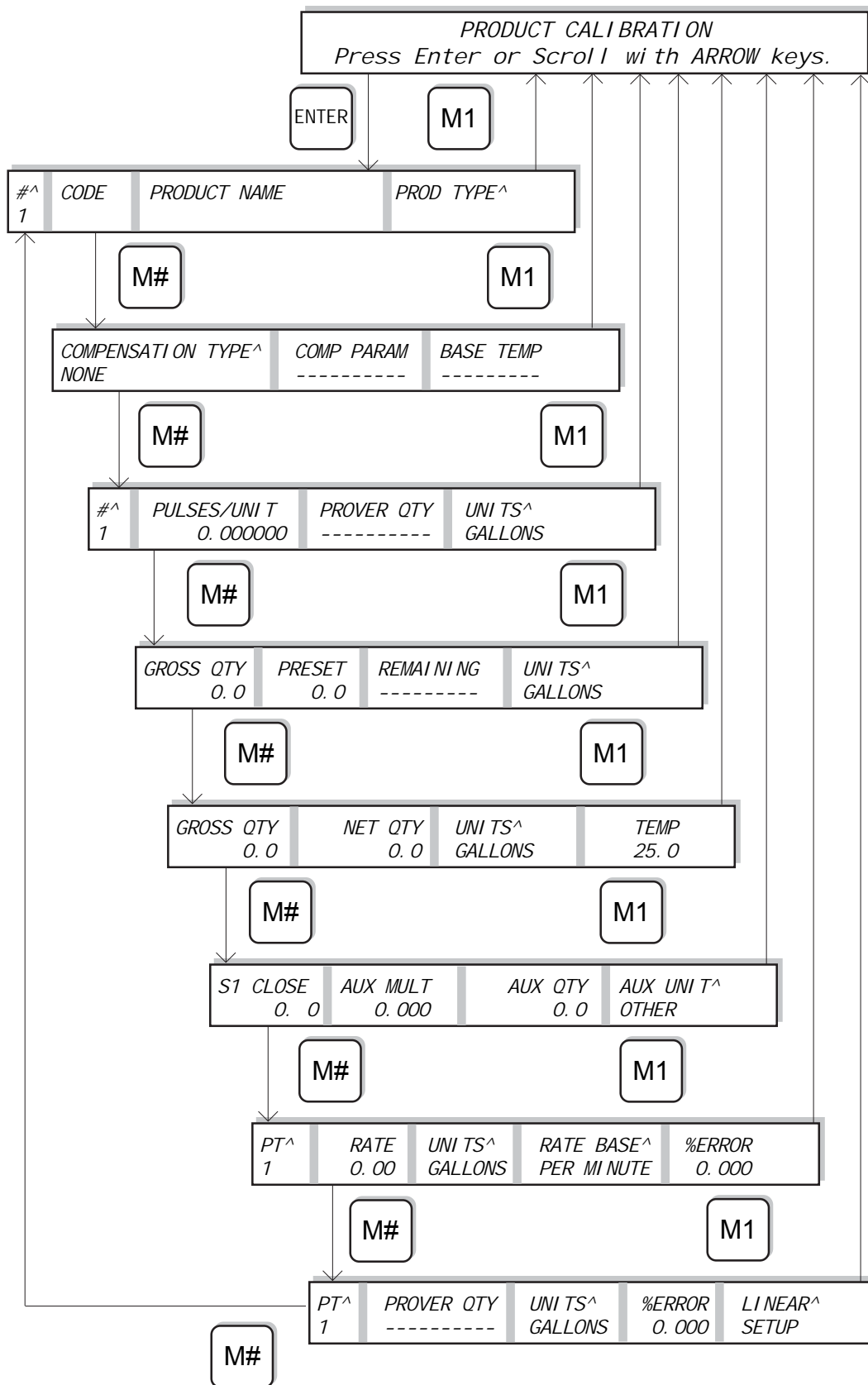



# Appendix D - Lap Pad Menu Flow Charts

## DIAGNOSTICS

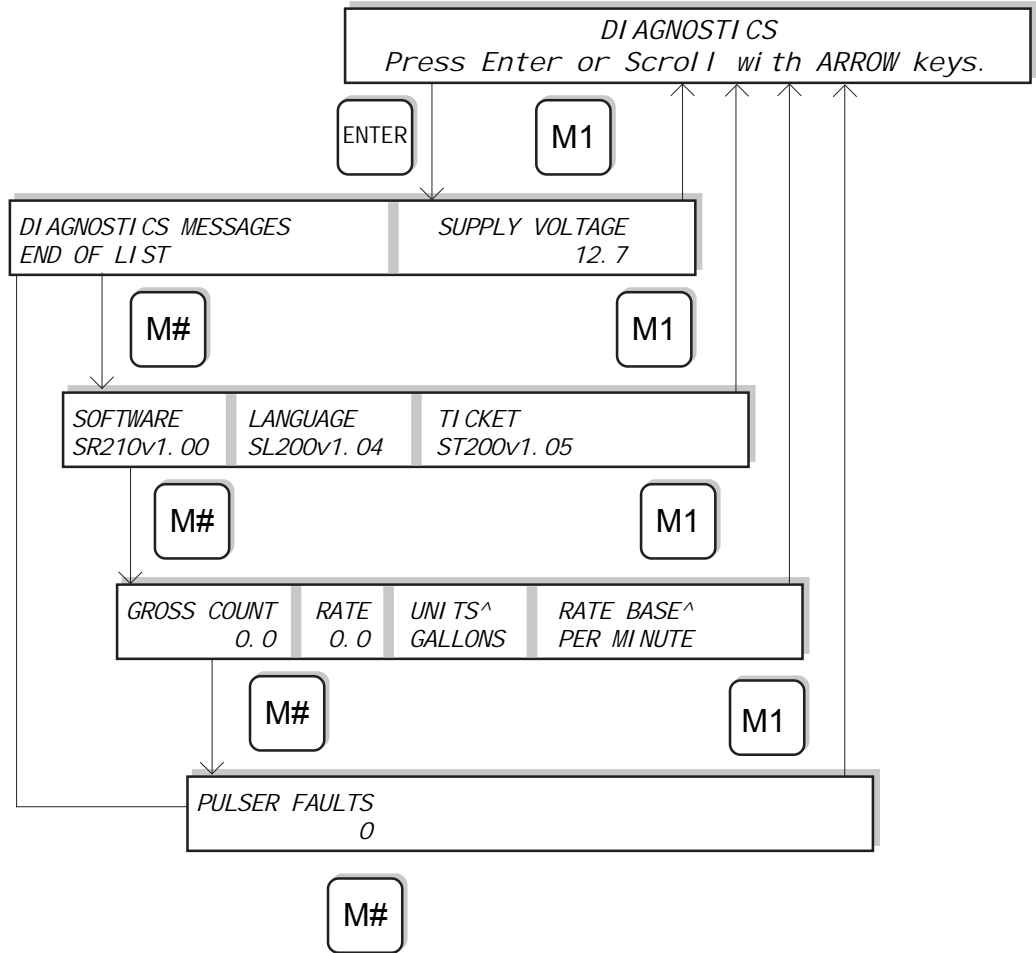

## SECURITY

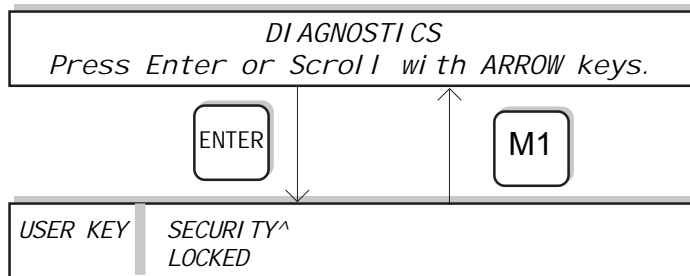

## FACTORY

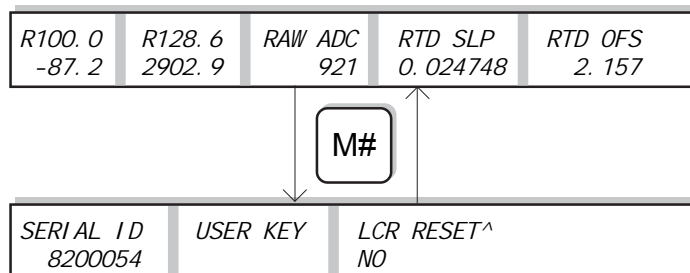

# Appendix E - Weights & Measures Prover Guide

---

This guide has been created to clearly convey the method for proving a meter system equipped with a LectroCount LCR electronic register without the use of a Lap Pad or external data entry device. This guide will only cover the software features of the LCR in the calibration/prover mode.

**NOTE:** The following method provides a means to check the overall meter accuracy as well as adjust the meter's "k-Factor". The k-Factor moves the entire meter accuracy curve either up or down. If it is believed that the meter curve itself may have changed (e.g. when a measuring chamber is replaced), and it is desired to use and/or change multi-point calibration, a Lap Pad or other data entry device must be used per the Set-Up & Operation Manual.

The LCR must initially be set-up and calibrated using a Lap Pad or data entry device. Once this has been accomplished, the LCR can be proved without using such a device. Only products with a valid pulse/unit (k-Factor) can be recalibrated using this feature.

1. Remove the Switch Plate cover.
2. Turn the Selector Switch to the calibration/prover position. This is accomplished by rotating the Selector Switch counter-clockwise to the 6:00 position.
3. The display will show "**000.000**". This represents the delivered volume as recorded by the register. The current calibration settings will be printed on a ticket.
4. Press the **SELECT** button one time. The display will show **Prod 1**". Press **INCREASE** to select from the programmed products (**Prod 1** to **Prod 4**). Only products that have been previously set-up and calibrated will be displayed. If only one product has been calibrated, only one **Prod #** will be available.
5. When the desired product number is displayed, press **SELECT**. The display will advance to Flowrate, "**F 0.0**".
6. Press **SELECT** and the display will advance to Temperature, "**42.5 °F**". If a temperature probe is not installed, the display will show "**999.9 °F**".
7. Press **SELECT** and the display will return to "**000.000**".
8. To start a delivery, press the **INCREASE** button one time. This takes the display through an "all segments and blanks" test and starts a delivery by activating the solenoid valve controls. (All segments and blanks: "**8.8:8.8:8.8**"). If the register display remains at zero, open the hose nozzle and begin to fill the prover. If the register **did not** remain at zero (the hose needed to be packed), leave the pump running and press the **INCREASE** button to stop the delivery. Then press the **SELECT** button until the display digits no longer flash. Press the **INCREASE** button on the LCR to start the actual delivery with a packed hose. Open the hose nozzle and start to fill the prover.
9. Once the prover is filled to the desired volume, close the hose nozzle and press the **INCREASE** button on the LCR to deactivate the solenoid controls and end the delivery.
10. If it is determined that **no change** to the meter k-Factor is desired, turn the Selector Switch clock-wise to exit the calibration/prover mode. Proving is complete. If it is determined that a change to the meter k-Factor is desired, use the **INCREASE** and **SELECT** buttons on the LCR to adjust the value on the register to match the volume of the prover. The following page contains an example.

# Appendix E - Weights & Measures Prover Guide

---

## k-Factor Adjustment Example:

Presume that the LCR register displayed "101.235" Units and the prover volume was determined to be "100.593" units at the end of step 9. ("Units" represents the units of measure as designated on the front cover of the LCR.)

When **INCREASE** is pressed in Step 9 above, the left most digit of the LCR register will be flashing on and off indicating that it can be changed. To change this value, press **INCREASE** to scroll through 0-9. The display digits will wrap around to 0 after 9 has been reached. When the desired value for the first position has been reached, press **SELECT** and the next digit to the right will flash on and off. In this example, no adjustment to the first digit is necessary.

The second digit also does not require adjustment, so press **SELECT** to advance to the third digit. The third digit, "1", will be flashing on and off and needs to be changed to 0 in order to match the prover volume. Press **INCREASE** to scroll through the digits until "0" is displayed. Press **SELECT** to accept that value and advance to the next digit, "2".

Press **INCREASE** until the number "5" is displayed. Press **SELECT** to advance to the next digit, "3". Continue in this fashion until all the digits on the display are adjusted to the prover volume: "100.593". When this is complete, none of the digits will be flashing on the display. A new k-Factor is recorded by the LCR. Turn the Selector Switch clock-wise to exit calibration/prover mode.

If a number is entered in this example that results in an unacceptable k-Factor, the display will show "Error". When this occurs, press **SELECT** and return to Step 7 and conduct another prover run.



**Backed by our Worldwide reputation for  
Quality, Accuracy and Advanced Design.**



**LIQUID CONTROLS**

A Unit of IDEX Corporation  
105 Albrecht Drive  
Lake Bluff, IL 60044-2242  
1.800.458.5262 • 847.295.1050  
Fax: 847.295.1057  
[www.lcmeter.com](http://www.lcmeter.com)

© 2007 Liquid Controls  
Pub. No. 500050  
(05/07)



**DNV**  
CERTIFICATED FIRM  
Certificate No. 08732



**DNV**  
CERTIFICATED FIRM  
Certificate No. 05049