



# AUSTIN A.40 MODELS

SERIES GS4 GD3 GD5 GV4 GP4 GGU4

## *Service Manual*

---

THE AUSTIN MOTOR COMPANY LIMITED BIRMINGHAM ENGLAND





# **AUSTIN**

## **A40 MODELS**

SERIES GS4 GD3 GD5 GV4 GP4 GGU4

# *Service Manual*



DECEMBER 1957

---

THE AUSTIN MOTOR COMPANY LIMITED

BIRMINGHAM, ENGLAND

## *Introduction*

This manual has been compiled to assist Austin Distributors and Dealer Organisations in the efficient servicing and maintenance of the A40 Models.

Each assembly of the major components is described in detail. In addition, comprehensive instructions are given for complete dismantling, assembling, adjusting and inspection of these assemblies. It is emphasized that only genuine Austin parts should be used as replacements for components found unfit for further service.

The information given, within these pages, is authentic and covers the models produced prior to the publication date on page 1. Modifications to later vehicles, which may become necessary, will be described in subsequent editions of the manual. When ordering spares it is imperative that operators use the 'Spare Parts List' of the appropriate model and not refer to the manual.

## THE "A40" O.H.V. ENGINE

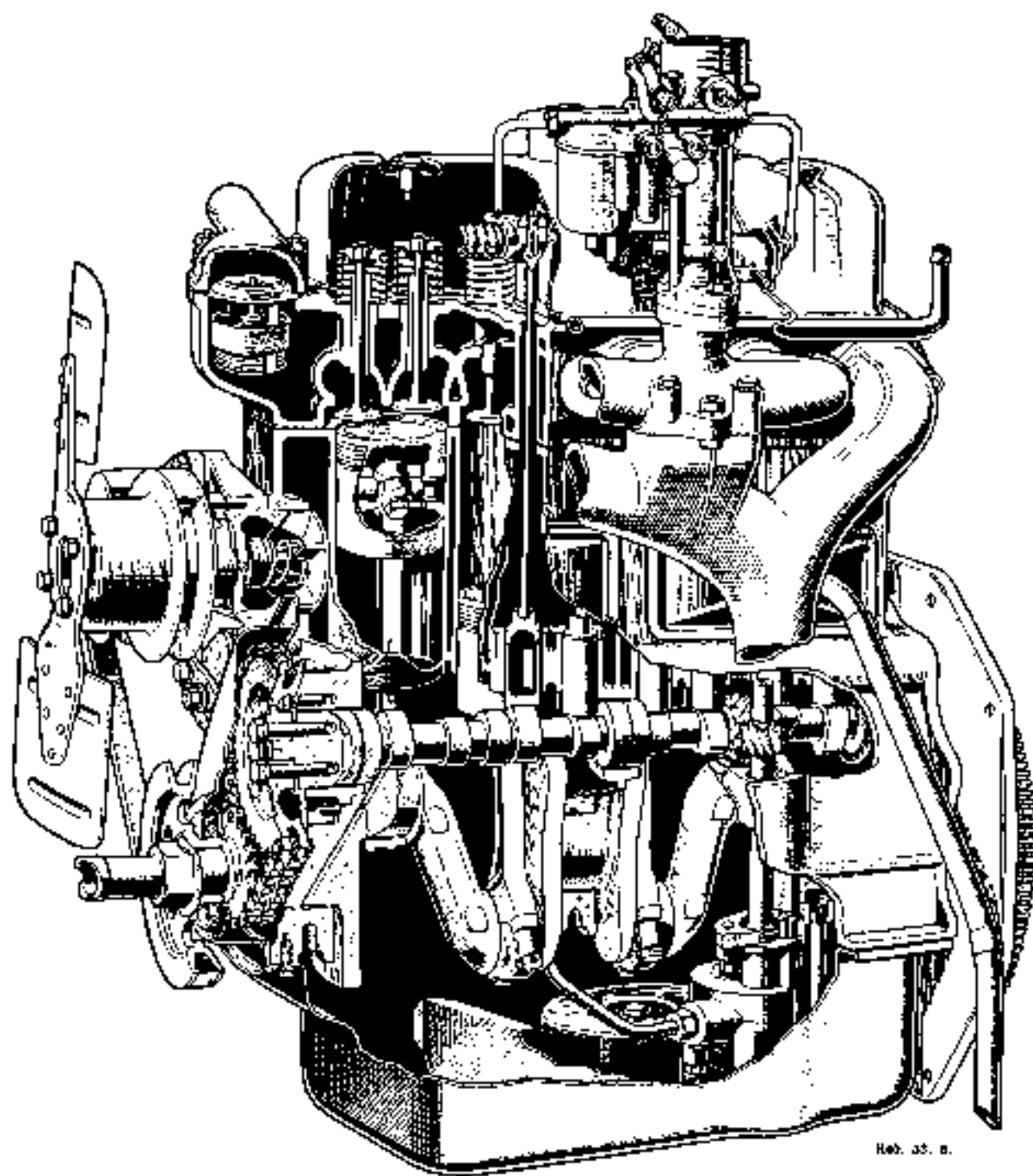

Ref. 35. 8.

A sectional view of the engine showing the detail of the main components. Although the A40 "Sports" manifolds and carburettors differ to those of the above illustration the main construction and servicing operations are identical unless otherwise stated.



THE "A40" SOMERSET SALOON

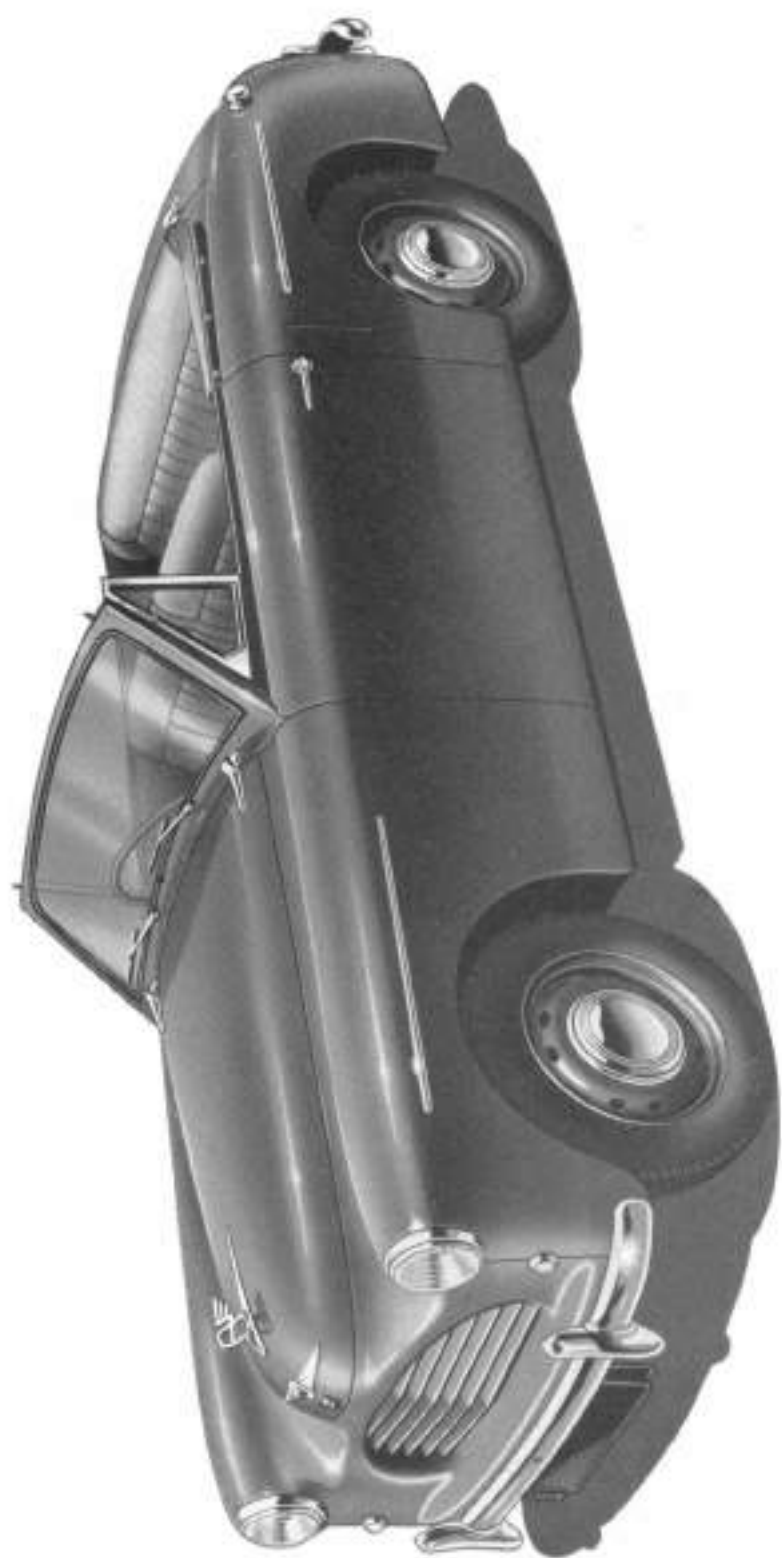

THE "A40" SPORTS



THE "A40" COUPÉ





THE "A40" 10-CWT. VAN



THE "A40" COUNTRYMAN



THE "A40" 10-CWT. PICK-UP



# GENERAL INDEX

Axle (Rear) .....	Section K	Ignition Equipment .....	Section O
Bodywork .....	" P	Instruments and Controls .....	" A
Brakes .....	" M	Interior Heating .....	" P
Clutch .....	" E	Lubrication Chart .....	" T
Cooling System .....	" B	Part Name Alternatives .....	" R
Electrical Equipment .....	" O	Propeller Shaft .....	" G
Engine .....	" D	Radio .....	" P
Frame .....	" L	Service Tools .....	" Q
Front Hubs and Independent Front Suspension .....	" H	Steering .....	" J
Fuel System .....	" C	Service Facilities .....	" S
Gearbox .....	" F	Suspension (Rear) .....	" L
		Tyres and Jacking .....	" N

General Specifications .....	Page xlv	Reassembling .....	Page 14	Service Operations—Engine Removed .....	Page 19
Regulation Attention .....	Page xviii	Relating to the Engine .....	Page 16	Bearing Caps .....	Page 24
<b>INSTRUMENTS AND CONTROLS</b>	Section A	Removal from Engine .....	Page 13	Camshaft Bearings .....	Page 21
Driving .....	Page 2	Testing .....	Page 15	Camshaft Withdrawal .....	Page 21
Foot Controls .....	Page 1	Testing on Engine .....	Page 15	Hyndee Removal .....	Page 22
Hand Controls .....	Page 3			Front Mounting Plate .....	Page 21
Instruments .....	Page 1	<b>Fuel Tank</b> .....	Page 1	Patent and Beres .....	Page 24
Starting .....	Page 1	Draining .....	Page 1	Patons and Connecting Rods .....	Page 22
<b>COOLING SYSTEM</b>	Section B	Gauge Unit .....	Page 1	Paton Removal .....	Page 24
Capacity .....	Page 1	Removal .....	Page 1	Paton Rings .....	Page 24
Circulation .....	Page 1	Replacement .....	Page 1	Rear Mounting Plate .....	Page 22
Description .....	Page 1			Removing the Crankshaft .....	Page 24
Fan Belt Adjustment .....	Page 2	Manifolds Subsoen .....	Page 2	Tappee Removal .....	Page 19
Overheating .....	Page 2	Exhaust Pipe .....	Page 3	Tongue Chain Filling .....	Page 21
Thermostat .....	Page 1	Manifold Sports .....	Page 2	Timing Cover .....	Page 19
		Throttle Linkage Subsoen .....	Page 2	Fitting Marks .....	Page 21
<b>Radiator</b> .....	Page 5	Throttle Linkage Sports .....	Page 2	Valve Timing Gear .....	Page 19
Flushing .....	Page 5				
Front Precautions .....	Page 2	<b>ENGINE</b>	Section D	<b>CLUTCH</b>	Section E
Protection—Anti-Freeze .....	Page 2	Lubrication .....	Page 4	Adjustments .....	Page 1
Protection—Draining .....	Page 3	Capacity .....	Page 4	Assembly .....	Page 4
Reassembly and Replacement .....	Page 5	Check for Loss of Pressure .....	Page 5	Cover Assembly .....	Page 1
Removing .....	Page 5	Circulation .....	Page 4	Data .....	Page 1
<b>Water Pump</b> .....	Page 4	Description .....	Page 4	Disassembling .....	Page 4
Bearings and Washers .....	Page 4	Draining .....	Page 4	Driven Plate Assembly .....	Page 1
Lubrication .....	Page 4	Filter—A.C. .....	Page 5	Left-hand Pedal Assembly .....	Page 3
Reassembly .....	Page 4	Filter—Purifier .....	Page 5	Refacing the Driven Plate .....	Page 5
Refitting Fan Blades .....	Page 4	Gauge and Filter Pick-Up .....	Page 6	Retining .....	Page 5
Removing .....	Page 4	Oil Pump .....	Page 6	Release Bearing .....	Page 1
Sealing Ring Assembly .....	Page 4	Oil Pump Release Valve .....	Page 6	Removing the Clutch .....	Page 3
Spindle—Removing .....	Page 4	Oil Sump Removal .....	Page 5		
<b>FUEL SYSTEM</b>	Section C	Pressure Gauge .....	Page 5	<b>GEARBOX</b>	Section F
Carburettor G.S.A. .....	Page 5	Refilling .....	Page 4	Data .....	Page 1
Accelerating Pump .....	Page 6	Valve Rocker Shaft .....	Page 6	Assembling the Gearbox .....	Page 8
Adjustment .....	Page 7			Change Speed Gate and Side Cover .....	Page 10
Air Cleaner .....	Page 1	<b>Assembly</b>	Page 1	Clutch Shaft and Fork .....	Page 10
Disassembling .....	Page 7	Clearances and General Data .....	Page 1	First Motion Shaft Gears .....	Page 9
Economy Device .....	Page 6	Diagnosis and Correction of Faults .....	Page 26	Front Cover .....	Page 10
Slow Running .....	Page 8	<b>Removal and Refitting of the Engine</b> .....	Page 15	Layshaft Gears .....	Page 9
Sticking .....	Page 4			Rear Cover .....	Page 10
Working Description .....	Page 3	<b>Service Operations—Engine in Position</b> .....	Page 7	Reverse Gears .....	Page 10
<b>Carburettor Sports</b> .....	Page 11	Cylinder Head Removal .....	Page 8	Selector Arm and Cross Shaft .....	Page 10
Adjustment .....	Page 10	Cylinder Head Replacement .....	Page 8	Selector Rods and Forks .....	Page 10
Air Cleaner .....	Page 12	Decarbonising .....	Page 8	Synchronase Sub-Assembly .....	Page 8
Description—General .....	Page 8	Distributor Removal .....	Page 11	Third Motion Shaft .....	Page 9
Description—Operational .....	Page 8	Ignition Timing .....	Page 13	<b>Disassembling the Gears</b> .....	Page 4
Maintenance .....	Page 9	Push Rod Removal .....	Page 7	Clutch Rod and Fork .....	Page 4
Piston .....	Page 10	Sparkling Plugs .....	Page 14	Cross Shaft Lever .....	Page 4
Piston Drivpin .....	Page 10	Valve Adjustment .....	Page 7	Drain Plug .....	Page 4
		Valves .....	Page 11	First Motion Shaft .....	Page 5
<b>Fuel Pump</b> .....	Page 12	Valve Grinding .....	Page 12	Front Cover .....	Page 4
Description and Operation .....	Page 12	Valve Guides .....	Page 12	Layshaft and Laygears .....	Page 4
Disassembling .....	Page 13	Valve Removal and Refitting .....	Page 10	Oil Seal—Rear .....	Page 5 & 10
Filter Cleaning .....	Page 13	Valve Seat Inset Removal .....	Page 10	Third Motion Shaft .....	Page 5
Inspection of Parts .....	Page 13	Valve Springs .....	Page 13	Reverse Gear .....	Page 4
				Selector Arm and Cross Shaft .....	Page 4
				Selector Rods and Forks .....	Page 4
				Side Cover and Change Speed Gate .....	Page 4

	Page		Page		Page
Examination for Wear .. .. .	7	Hubs .. .. .	1	Fire Up .. .. .	11
Beatings .. .. .	7	Reassembly .. .. .	1	Headlamps - Bulb Replacement .. .. .	13
Clutch Shaft Bushes .. .. .	7	Renewed .. .. .	1	Headlamps - Replacing a Light Unit .. .. .	17
First and Third Motion Shaft Bush .. .. .	7	Replacement .. .. .	1	Headlamp Setting .. .. .	16
Gear Synchronising Cones .. .. .	7			High Tension Cables .. .. .	14
Large Thrust Washers .. .. .	7	<b>REAR SUSPENSION</b> .. .. .	<b>Section L</b>	Horn .. .. .	15
Layshaft and Bushes .. .. .	7	Springs .. .. .	2	Horn—Adjustment .. .. .	15
Third Motion Shaft Sleeve .. .. .	7	Data .. .. .	1	Ignition Coil .. .. .	14
		<b>DESCRIBE</b> .. .. .	1	Lighting .. .. .	15
		Disassembling .. .. .	2	Number Plate Illumination .. .. .	18
		Reassembly .. .. .	7	Sidelamps .. .. .	18
		Renewed .. .. .	7	Stop Tail Lamps .. .. .	18
		Shackle Bolt Renewal .. .. .	7	Starter .. .. .	11
		Shackle Removal .. .. .	1	Starter - Dismantling .. .. .	13
				Starter—Normal Service .. .. .	12
		Shock Absorbers and Anti-Roll Bar .. .. .	1	Starter—Reassembly .. .. .	11
		Description .. .. .	1	Starter Removal .. .. .	12
		Rolling .. .. .	1	Starter Switch .. .. .	12
		Rubber Bushes .. .. .	1	Starter—Testing .. .. .	12
		Fastening .. .. .	1	Travellers - Description .. .. .	15
		Looping Up .. .. .	1	Windscreen Wiper .. .. .	15
		<b>BRAKES</b> .. .. .	<b>Section M</b>	<b>Location and Remedy of Faults</b> .. .. .	18
		Data .. .. .	1	Clipping Circuit .. .. .	19
		Handbrake .. .. .	1	Clipping Circuit .. .. .	19
		Principle of System .. .. .	1	Lighting Circuit .. .. .	20
				Starter Motor .. .. .	20
		Adjustment and Maintenance .. .. .	6		
		Bleeding the System .. .. .	6		
		Front Brakes .. .. .	3		
		Rear Brakes .. .. .	4		
		Replenishment of Fluid .. .. .	6		
		Fitting of Replacement Shoes .. .. .	5		
		Front Brakes .. .. .	5		
		Rear Brakes .. .. .	6		
		General Advice .. .. .	7	<b>BODYWORK</b> .. .. .	<b>Section P</b>
				Care of the Bodywork .. .. .	1
		Master Cylinder .. .. .	5		
		Assembly .. .. .	5	<b>Dismantling and Assembly of Body</b> .. .. .	
		Dismantling .. .. .	5	Parts (Saloon and Coupe) .. .. .	1
				Apron .. .. .	2
				Bonnet Top .. .. .	1
				Bonnet Surround and Grille .. .. .	1
				Bumpers .. .. .	7
				Facem and Instrument Board .. .. .	7
				Fifth Plate .. .. .	2
				Finger Wring and Ruffles .. .. .	2
				Heater .. .. .	8
				Head - Coupe .. .. .	9
				Head .. .. .	11
				Rear Wings .. .. .	1
				Seating .. .. .	7
				Shining Roof .. .. .	8
				Valance Panel .. .. .	4
				Windows and Doors .. .. .	5
				Windscreen .. .. .	4
				<b>Dismantling and Assembly of Body</b> .. .. .	
				Parts (Commercial) .. .. .	13
				Bonnet Top .. .. .	11
				Bumpers and Apron .. .. .	14
				Facia Panel .. .. .	15
				Front Wings and Fifth Plate .. .. .	11
				Heater Unit .. .. .	15
				Rear Wheel Covers .. .. .	14
				Seating .. .. .	16
				Windows and Doors .. .. .	16
				Windscreen .. .. .	14
				<b>Dismantling and Assembly of Body</b> .. .. .	
				Parts (Sports) .. .. .	17
				Bonnet Top .. .. .	17
				Body Lid .. .. .	20
				Bumpers .. .. .	19
				Doors and Windows .. .. .	22
				Facia Panel .. .. .	21
				Fifth Plate .. .. .	18
				Front Wings .. .. .	18
				Grille .. .. .	15
				Heater .. .. .	25
				Head .. .. .	22
				Rear Face .. .. .	20
				Rear Wings .. .. .	18
				Seating .. .. .	24
				Shroud .. .. .	17
				Windscreen .. .. .	20

		Page		Page		Page
Removing and Refitting (Saloon and Coupé) ..	the Body	1	SERVICE TOOLS	Section Q	PART NAME ALTERNATIVES	Section R
Removing and Refitting (Commercial) ..	the Body	16	Engine and Clutch Tools	1		
Removing and Refitting (Sports) ..	the Body	25	Front Suspension and Hub Tools	3		
			Gearbox Tools	3		
			Oil Pan	6		
			Rear Axle Tools	4		
			Steering and Chassis Tools	5		
					SECTION FACILITIES	Section S
					LUBRICATION	Section T

# GENERAL SPECIFICATIONS

**T**HIS manual contains information for vehicles of chassis number 657001 and engine number 700001 onwards. Some models prior to this were fitted with series G.S.3. engine (see manual publication No. 441D). When ordering parts note engine and chassis numbers quoted on spare parts list.

The engine number is located on the right-hand side of the cylinder block and the chassis number on the chassis, adjacent to the engine front mounting bracket, on the opposite side of the steering column. For quick reference these numbers are stamped on a plate attached to the sun visor on all models except the Sports, where it is fixed to the inside of the glovebox lid. Except where specifically stated, all information given for the Saloon should be regarded as also applying to the Coupé and Commercial models.

## ENGINE

### Dimensions (Saloon)

No. of cylinders 4; Bore 2.578-ins. (65.48mm.); stroke 3.5-ins. (89mm.); R.A.C. rating 10.6; capacity 73.17 cu. ins. (1,200 c.c.); B.H.P. 42 (42.58 C.V.) at 4,500 r.p.m.; Max. torque 58 lbs./ft (8.02 kgm.) at 2,400 r.p.m.; compression ratio 7.2 to 1; oil pressure 45 to 50 lbs. per sq. in. (3.16 to 3.51 kg./cm.<sup>2</sup>)

### Dimensions (Sports)

No. of cylinders 4; Bore 2.578-ins. (65.48mm.); stroke 3.5-ins. (89mm.); R.A.C. rating 10.6; capacity 73.17 cu. ins. (1,200 c.c.); D.H.P. 46 (46.63 C.V.) at 5,000 r.p.m.; max. torque 59 lbs./ft (8.15 kgm.) at 2,400 r.p.m.; compression ratio 7.2 to 1; oil pressure 45 to 50 lbs. per sq. in. (3.16 to 3.51 kg./cm.<sup>2</sup>).

### Valve Timing and Clearances

Inlet valve opens 5° B.T.D.C. and closes 45° A.B.D.C. Exhaust valve opens 40° B.B.D.C. and closes 10° A.T.D.C. Inlet and exhaust valve clearances.—.015-ins. (.38 cm.).

## FUEL SYSTEM

### Carburettor (Saloon)

Make—Zenith. Type—30 V16-S; Choke tube—25; Main jet—90; Compensating jet—65; slow running jet—50; Needle and seating—.5; Pump jet—50.

### Carburettor (Sports)

Twins S.U. Carburettors inclined at an angle 20°. Needle—model EK.

### Fuel Pump

A.C. Sphinx fuel pump type "U", normal working pressure 1½ to 2½ lbs. per sq. in. (.105 to .189 kg./cm.<sup>2</sup>).

## CLUTCH

A flexible dry plate Borg and Beck clutch. Pedal free movement ¾-in. (1.9 cm.).

## GEARBOX

Four forward speeds and reverse. Steering column mounted gear lever, synchromesh engagement for second third and top. Ratios; 1st. 3.89, 2nd. 2.44; 3rd. 1.54; 4th. direct; reverse 5.39.

## REAR AXLE

Spiral bevel three-quarter floating. Crown wheel and pinion ratios: Saloon 37:7; Sports 36:7; Commercial 43:7.

### Overall Gear Ratios

	1st	2nd	3rd	4th	Reverse
Saloon and Coupé	29.54	12.88	8.13	5.28	28.46
Sports	20.00	12.52	7.89	5.14	27.68
Commercial	23.89	14.95	9.43	6.14	33.09

## STEERING

14 to 1 ratio cam gear steering. Toe-in 1/16-in. to 1/8-in.

## SUSPENSION

### Front

Independent coil springs. Castor angle 2½°. Camber angle 1°. Swivel pin inclination 6½°.

### Rear

Semi-elliptic underslung reverse camber springs.

## BRAKES

Giftling hydraulic front and rear. Front brakes of two leading shoe design. Pedal free movement—¾-in. Handbrake operates mechanically on rear wheels only.

## FRAME

Welded pressed steel frame with full length box section side, front and rear members. The centre part is stiffened by cross bracing. Additionally, the cross bracing of the Sports chassis is completely boxed in to give the greater torsional and diagonal strength required for a sporting car.

## CAPACITIES

Petrol tank 8½ gallons 10.5 U.S. gallons 37 litres; Oil sump 7 pints 8.4 U.S. pints 4 litres inclusive of filter; cooling system (Saloon) 12 pints 14.4 U.S. pints 6.82 litres, (Sports) 14 pints—16.8 U.S. pints 7.9 litres; Gearbox 3 pints 3.6 U.S. pints 1.68 litres; Rear axle 2½ pints 2.7 U.S. pints 1.26 litres; Battery capacity 38 ampere hours at 10 hour discharge rate.



## LEADING DIMENSIONS

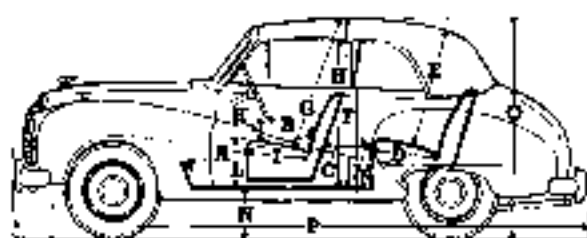
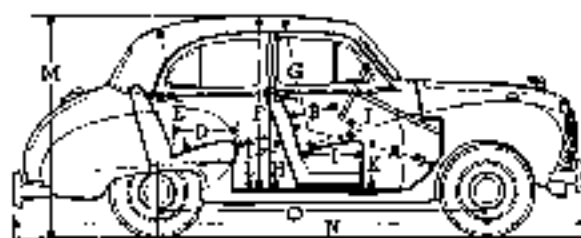

440 SALOON DIMENSIONS		English		Metric	
		ft.	ins.	metres	milli-
Pedal to Seat Squab	A	1	0	1.00	0.30
Steering Wheel to Seat Squab	B	1	5	0.43	0.25
Distance between Seats	C	1	10	0.38	0.20
Rear Seat Cushion Depth	D	1	10	0.30	0.18
Height over Rear Seat	E	1	10	0.48	0.28
Maximum Interior Height	F	1	11	1.39	0.75
Height over Front Seat	G	1	10	0.35	0.20
Minimum Height of Drive Opening	H	1	7	1.04	0.58
Front Seat Cushion Depth	I	1	6	0.41	0.23
Steering Wheel to Seat Cushion	J	1	5	0.14	0.08
Front Seat Cushion above Floor	K	1	1	0.12	0.07
Rear Seat Cushion above floor	L	1	2	0.17	0.10
Overall Height	M	1	4	1.61	0.90
Overall Length	N	1	3	4.03	2.28
Wheelbase	O	1	3	2.53	1.42
Overall Width	P	1	3	1.60	0.89
Body Width between Centre Pillars (at wheel)	Q	1	4	0.22	0.12
Front Seat Cushion Width (max.)	R	1	10	0.54	0.30
Rear Seat Cushion Width	S	1	11	1.00	0.55
Maximum Width over Rear Seat	T	1	13	1.19	0.66
Track, front (at ground)	U	4	0	1.22	0.67
Track, rear	V	4	2	1.37	0.75
Ground Clearance	W	4	7	0.39	0.21
Turning Circle	X	17	0	31.36	17.50
Luggage Compartment—Height of Opening	Y	1	8	0.51	0.28
Luggage Compartment—Width of Opening	Z	1	7	0.40	0.22
Luggage Compartment—Maximum Depth	AA	1	0	0.44	0.24
Luggage Compartment—Approx. Capacity	AB	1	0	1.28 cu. ft.	36.00 lit.
Luggage Carrier Load	AC	1	0	51 kg.	113 lbs.
Approx. Weight—less spare wheel, tools and fuel, plus oil and water	AD	1	9	971 kg.	2140 lbs.

440 COUPE DIMENSIONS		English		Metric	
		ft.	ins.	metres	milli-
Pedal to Seat Squab	A	1	5	1.04	0.58
Steering Wheel to Seat Squab	B	1	5	0.43	0.25
Maximum Distance between Seats	C	1	10	0.28	0.15
Rear Seat Cushion Depth	D	1	7	0.40	0.22
Height over Rear Seat	E	1	10	0.65	0.36
Maximum Interior Height	F	1	11	1.19	0.66
Height over Front Seat	G	1	10	0.32	0.18
Height of Rear Opening	H	1	4	0.92	0.51
Front Seat Cushion Depth	I	1	6	0.47	0.26
Front Seat Cushion Width	J	1	9	0.54	0.30
Steering Wheel to Cushion	K	1	5	0.14	0.08
Front Cushion above Floor	L	1	1	0.15	0.08
Rear Cushion above Floor	M	1	1	0.14	0.08
Minimum Height—Floor to Ground	N	1	3	0.39	0.21
Overall Height	O	1	4	1.59	0.88
Overall Length	P	13	7	4.05	2.28
Overall Width	Q	1	3	1.60	0.89
Seat Width (at knee height)	R	1	3	1.14	0.63
Rear Seat Maximum Width	S	1	3	1.00	0.55
Wheelbase	T	4	2	2.35	1.31
Track, front (at ground)	U	4	0	1.22	0.67
Track, rear	V	4	2	1.37	0.75
Ground Clearance	W	4	7	0.39	0.21
Turning Circle	X	17	0	11.58	6.40
Luggage Compartment—Height of Opening	Y	1	8	0.51	0.28
Luggage Compartment—Width of Opening	Z	1	7	0.40	0.22
Luggage Compartment—Depth of Platform	AA	1	0	0.44	0.24
Luggage Compartment—Capacity	AB	10	cu. ft.	0.28 cu. m.	7.80 cu. ft.
Luggage Carrier Load	AC	1	0	51 kg.	113 lbs.
Approximate Weight—less spare wheel, tools and fuel—plus oil and water	AD	1	9	941 kg.	2075 lbs.

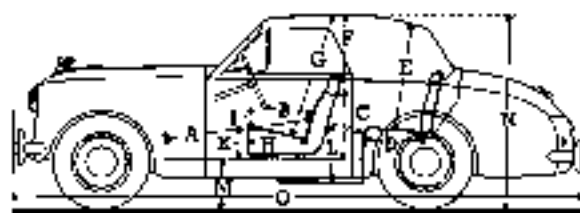

440 SPORTS DIMENSIONS		English		Metric	
		ft.	ins.	metres	milli-
Pedal to Seat Squab	A	1	0	1.00	0.30
Steering Wheel to Seat Squab	B	1	1	0.25	0.14
Distance between Seats	C	1	1	0.17	0.09
Rear Seat Cushion Depth	D	1	5	0.41	0.23
Height over Rear Seat	E	1	7	0.41	0.23
Maximum Interior Height	F	1	6	1.07	0.59
Height over Front Seat	G	1	1	0.94	0.52
Front Seat Cushion Depth	H	1	6	0.46	0.25
Front Seat Cushion Width	I	1	7	0.31	0.17
Steering Wheel to Cushion	J	1	4	0.11	0.06
Rear Cushion above Floor	K	1	0	0.27	0.15
Front Cushion above Floor	L	1	0	0.47	0.26
Minimum Height—Floor to Ground	M	1	5	0.39	0.21
Overall Height	N	4	0	1.36	0.75

440 SPORTS DIMENSIONS		English		Metric	
		ft.	ins.	metres	milli-
Overall Length	O	17	0	4.04	2.28
Overall Width	P	5	1	1.55	0.86
Seat Width (at knee height)	Q	3	11	1.20	0.66
Body Width over Front Seat	R	4	11	1.23	0.68
Rear Seat Maximum Width	S	3	7	0.99	0.54
Wheelbase	T	7	8	2.33	1.30
Track (front)	U	4	0	1.21	0.67
Track (rear)	V	4	4	1.26	0.70
Ground clearance	W	4	4	0.19	0.10
Turning circle	X	18	0	11.58	6.40
Luggage Compartment—Height of Opening	Y	1	7	0.50	0.27
Luggage Compartment—Width of Opening	Z	1	10	1.17	0.64
Luggage Compartment—Depth of Platform	AA	2	9	0.84	0.46
Luggage Compartment—Capacity	AB	15	cu. ft.	0.37 cu. m.	10.40 cu. ft.
Approximate Weight, less spare wheel, tools and fuel	AD	1	8	934 kg.	2060 lbs.

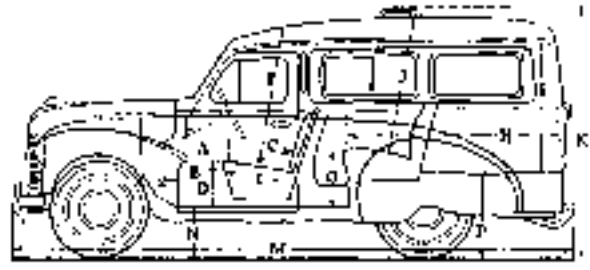
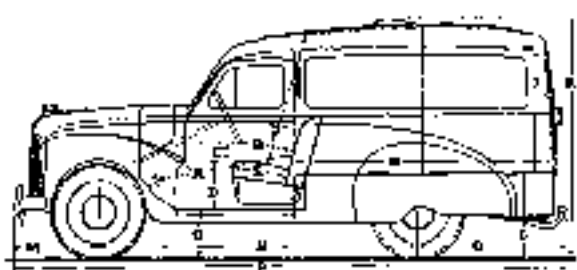

ALL VAN DIMENSIONS		English	Metric
Seat to Seat Spacing	A	11.88	0.99
Steering Wheel to Seat Spacing	B	1.1	0.14
Steering Wheel to Seat	C	1.62	0.14
Height of Rearview Mirror	D	1.12	0.14
Seat Cushion Depth	E	1.5	0.41
Height over Seat	F	1.5	0.40
Top Floor to Ground (inclined)	G	1.4	0.40
Length of Body (inter)	H	6.0	1.51
Body Interior Height	I	5.7	1.40
Height of Rear Door Opening	J	5.1	1.30
Overall Height (inclined)	K	6.11	1.56
Body Height (inclined)	L	5.8	1.50
Centre of Front Wheel to Bumper	M	2.24	0.7
Wheelbase	N	4.1	1.15
Centre of Rear Wheel to Bumper	O	5.67	1.76
Overall Length	P	5.77	1.76
Overall Width	Q	4.41	1.12
Body Interior Width	R	3.72	1.04
Width between Wheelarches	S	3.1	1.00
Width of Rear Door Opening	T	3.11	1.02
Track, front	U	4.11	1.24
Track, rear	V	4.21	1.36
Turning Circle	W	5.9	1.58
Capacity (seats)	X	9	9
Capacity (weight (dry weight wheel, fuel and fuel, plus oil and water))	Y	116 cwt. 0	1.25 ton. 0
		10675 kg.	124 kg.

VAN DIMENSIONS		English	Metric
Steering Wheel to Seat	A	1.7	0.14
Seat to Seat Spacing	B	11.4	0.91
Steering Wheel to Seat Spacing	C	1.4	0.14
Height of Rearview Mirror	D	1.07	0.14
Height of Front Seat	E	1.7	0.44
Height over Front Seat	F	1.3	0.40
Height of Rear Seat (dry floor)	G	1.2	0.47
Height of Rear Seat (incl. oil to Rear Floor)	H	5.12	1.35
Height of Rear Door Opening	I	1.7	0.45
Height over Rear Seat	J	1.7	0.45
Overall Height	K	6.14	1.66
Body Height (inclined)	L	5.5	1.74
Overall Length	M	5.77	1.76
Centre of Front Wheel to Bumper	N	1.7	0.55
Centre of Rear Wheel to Bumper	O	2.0	0.60
Overall Width	P	4.43	1.14
Max. Interior Width	Q	3.73	1.07
Width between Wheelarches	R	3.11	1.00
Width of Rear Door Opening	S	3.11	1.02
Wheelbase	T	4.1	1.15
Track, front	U	4.11	1.24
Track, rear	V	4.21	1.28
Turning Circle	W	5.9	1.58
Ground Clearance	X	7.4	0.19
Capacity (weight (dry weight wheel, fuel and fuel, plus oil and water))	Y	21 cwt. 00 lb.	224 kg.

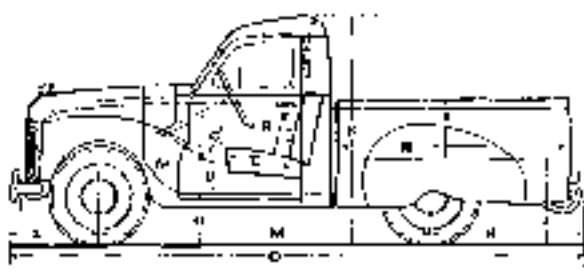

ALL PICK-UP DIMENSIONS		English	Metric
Seat to Seat Spacing	A	11.51	0.97
Steering Wheel to Seat Spacing	B	1.1	0.14
Steering Wheel to Seat	C	1.62	0.14
Height of Rearview Mirror	D	1.12	0.14
Seat Cushion Depth	E	1.5	0.40
Height over Seat	F	1.4	0.41
Top Floor to Ground	G	1.4	0.41
Length of Body (inter)	H	5.74	1.41
Height over Body Side	I	5.1	1.30
Body Height to Ground	J	4.1	1.04
Overall Height	K	5.8	1.76
Centre of Front Wheel to Bumper	L	2.24	0.7
Wheelbase	M	4.1	1.15

ALL PICK-UP DIMENSIONS		English	Metric
Centre of Rear Wheel to Bumper	N	3.7	1.09
Overall Length	O	5.4	1.67
Overall Length (to ground down)	P	4.4	1.35
Overall Width	Q	4.43	1.14
Track, front	R	4.12	1.24
Track, rear	S	4.21	1.28
Interior Body Width	T	3.73	1.07
Width between Wheelarches	U	3.1	1.00
Ground Clearance	V	7.4	0.19
Turning Circle	W	5.9	1.58
Capacity (weight (dry weight wheel, fuel and fuel, plus oil and water))	X	21 cwt. 40 lb.	231 kg.

# REGULAR ATTENTIONS

The following is a convenient list of regular attentions which the car should receive to keep it in good mechanical condition. These instructions should be closely followed, whether the attentions are performed by the owner or the local garage.

The attentions under the Daily and Weekly headings are based on the assumption that the maximum mileage per week does not exceed 500, but see "After Sales Service" as detailed in the Handbook for special attention during the first 1,000 miles.

Under more arduous conditions, such as very dusty or very muddy roads, long distances at high speeds or with heavy loads, it will be advisable to attend to chassis lubrication more frequently.

## DAILY

### Engine

Check the level of oil in the sump and top up if necessary to the full mark on the dipstick, situated on the right-hand side of the engine. When adding oil through the oil filler, at the rear end of the valve rocker cover, pour slowly to avoid the oil overflowing. If the engine has been running, allow a few minutes for the oil to settle before checking the level.

### Radiator

Check the level of water in the radiator and top up if necessary. Fill to just below the top of the filler plug thread, when the engine is cold.

### Fuel Tank

Check the quantity of fuel in the tank and add upper cylinder lubricant if desired.

## EVERY 500 MILES (800 Km.)

### Shackle Pins

These are on the rear ends of the rear road springs and should be given a charge of oil once a week. There are two nipples, one for each top shackle.

### Front Suspension

Apply the oil gun to each of the lower wishbone arm outer bearing nipples.

### Swivel Axles

Apply the oil gun on the two nipples on each swivel axle. This is best done with the axle jacked up since the oil is then able to penetrate to the thrust side of the bearing.

### Steering Connections

Apply the oil gun to the steering centre cross tube nipples (2) and the steering side cross tube nipples (4). Top up the steering idler with oil via the filler plug in the top cap.

### Wheels and Tyres

Check the tightness of the wheel nuts and check the tyre pressures, using a tyre gauge, and inflate if necessary. See that all valves are fitted with valve caps and inspect the tyres for injury. Remove any flints or nails from the

treads and ensure that there is no oil or grease on the tyre, since these substances prove injurious to rubber.

For recommended pressures, see Section N.

A tyre that loses more than three to four pounds per square inch in a week should be suspected of a puncture, but first make sure that the valve is not leaking.

## FIRST 500 MILES (800 Km.)

### Engine

On new and reconditioned engines the sump should be drained and refilled with new oil after the first 500 miles. At the same time as these changes are made, the cylinder head nuts should be tested and tightened if it is found necessary.

With the new engine, during the running in and settling down period (approximately 1,000 miles) a slight falling off of power sometimes develops; it is then advisable to lightly grind-in the valves and re-set the valve clearances. On such occasions there is no need to decarbonise the tops of the pistons.

### Gearbox and Rear Axle

After 500 miles on new vehicles, drain and refill the gearbox and rear axle.

Always drain the oil after a run, since it will flow more easily when warm.

**EVERY 2,000 MILES (3,200 Km.)****Engine**

Drain the sump and refill with new oil. Capacity is 7 pints, inclusive of filter.

**Gearbox**

Check the level and top up if necessary. For access lift the front carpet and remove the small plate on the side of the gearbox covering. The filler plug is then accessible. Clean any dirt or grit away from around the plug. Remove the plug and fill up to the bottom of the threads. This gives the correct level.

**Shock Absorbers**

Check all shock absorbers for leaks and see that the rubber bushes are undamaged.

**Clutch Pedal**

With the oil gun, lubricate the nipple at the pivot of the lever.

On left-hand drive models the nipple is situated on the underside of the larger diameter tube of the telescopic fitting, see Section L, page 3.

**Brakes**

Examine the brakes and adjust if necessary. Apply the oil gun to the balance lever on the rear axle case, the handbrake pivot and the pedal pivot nipple.

**Rear Axle**

Check the level and replenish if necessary. The correct oil should be used and injected into the axle casing from underneath, using the adaptor on the oil gun.

First remove the plug, which is on the right lower front side of the axle carrier, then place the end of the adaptor into the oil hole and inject the oil.

The plug also serves as an oil level indicator. Therefore, do not replace the plug at once, but give time for the superfluous oil to run out if too much has been injected. This is most important, because, if the rear axle is overfilled, the lubricant may leak through the brakes and render them ineffective. Wipe away the excess oil from the casing.

**Steering Column**

Lubricate the pit washer at the top of the steering column by adding a few drops of light machine oil through the hole in the steering wheel hub close to the steering column.

**Battery**

Ascertain the state of charge of the 12-volt battery by taking hydrometer readings. The specific gravity readings should be:—

Fully charged	...	...	...	1.280	1.300
Half charged	...	...	...	approx. 1.201	
Discharged	...	...	...	below 1.150	

These figures are for an assumed electrolyte temperature of 60 deg. F.

Check that the electrolyte in the cells is just level with the tops of the separators. If necessary add a few drops of distilled water. Never use tap water as it contains impurities detrimental to the battery.

Never leave the battery in a discharged condition. If the car is to be out of use for any length of time, have the battery removed and charged about once a fortnight.

**Brake Supply Tank**

Inspect and refill to the correct level. This tank is situated on the radiator mounting frame of the Saloon and secured to the scuttle of the Sports and Commercials. Use only the recommended fluid.

**EVERY 3,000 MILES (4,800 Km.)****Sparkign Plugs**

Remove the plugs and clean off all carbon deposit from the electrodes, insulators and plug threads with a stiff brush dipped in paraffin. Alternatively the plugs may be taken to a local Austin dealer for cleaning in a special machine.

Clean and dress the plug points and reset to the correct gap of .018 in. for the Saloon and .025 in. for the Sports.

Before replacing the plugs check that the copper washers are in a sound condition. Never over-tighten a plug but ensure that a good joint is made between the plug body, the copper washer and the cylinder head.

Saloon and Commercials—use Champion N.8B Long Reach 14 mm. plugs;

Sports—use Champion N.A.8 Long Reach 14 mm. plugs.

**Distributor Cam and Drive Shaft Bearings**

Lubricate the distributor camshaft bearings by withdrawing the rotor arm from the top of the distributor spindle and carefully adding a few drops of this machine oil round the screw exposed to view. Take care to refit the arm correctly by pushing it on to the shaft and turning until the key is properly located.

**Distributor Cap**

Apply a trace of engine oil to the distributor cap. Do not let any oil reach the contact breaker points.

**Distributor Automatic Advance**

Remove the distributor cap and add a few drops of engine oil through the hole in the contact breaker base through which the cap passes.

**EVERY 5,000 MILES (8,000 Km.)****Air Cleaner**

**Sahara:** Every 5,000 miles the air cleaner should be removed, cleaned and "watted" with fresh oil. To do this, slacken the clamping bolt and release the breather pipe from the valve rocker cover, lift off the air cleaner and then thoroughly rinse the lowered end in a shallow dish of petrol.

After drying, the metal gauze mesh should be re-oiled with clean engine oil, allowing the surplus oil to drain off before refitting the cleaner to the carburetter.

An oil bath type filter is fitted to cars for the export market. The oil therein should be checked and the gauze cleaned regularly.

**Gearbox**

Drain when the oil is warm, after a run, and refill to the level of the filler plug with new oil. Capacity, 3 pints.

**Rear Axle**

It is wise to drain the rear axle after a run, as the oil will flow more freely when warm, then refill to the level of the filler plug with new oil. Capacity, 2½ pints.

**Front Road Wheel Hubs**

Unscrew the hub cap and recharge with grease. It is important that the hubs are not given too much grease as it may penetrate to the brake shoes.

**Rear Road Wheel Hubs**

These are packed with grease upon assembly and do not require greasing attention.

**Fuel System**

Check the flow of the fuel at the carburetter inlet union and, if necessary, clean the petrol filters in the pump and in the carburetter inlet union, also clean the jets.

**Fan Belt**

The fan belt must be sufficiently tight to prevent slip at the dynamo and water pump, yet there should be sufficient slackness to move the centre of the belt sideways about one inch.

To make any necessary adjustment, slacken the bolts and raise or lower the dynamo until the desired tension of the belt is obtained. Then securely lock the dynamo in position again.

**Radiator**

Flush out the cooling system by opening the drain taps. There is one at the bottom of the radiator and another on the right side at the rear of the crankcase. Open the heater water cock. Water should then be allowed to run through until it comes out clear.

When refilling, and particularly if cold water is used, a few minutes must be allowed for air to escape past the thermostat valve before final topping up is effected.

In winter, when flushing the radiator, take care to preserve the cooling mixture if anti-freeze has been added.

**Steering Box**

The steering box should be topped up with oil, using the special adaptor on the oil gun. Take out the hexagon plug on the side of the steering box to inject the oil. Make certain that grit does not enter the casing during the operation and wipe away any excess oil afterwards.

**Speedometer Drive**

Disconnect the cable from the speedometer end and pull the inner member out of the casing. Lubricate by dipping it in fairly thick oil.

To reassemble, thread the oily shafting into the casing, giving a twisting movement while threading since this will help to engage it easily at the gearbox end. When the engagement is felt the shafting can be pushed right home so that the top square end stands out from the casing approximately ¼ inch.

**General Check**

Examine and, if necessary, tighten all bolts and nuts of such components as road spring clips, shock absorber retaining bolts and body mounting bolts.

Examine other parts, such as steering connections, brake rods, etc., neglect of any may be followed by an expensive repair and inability to use the car for a lengthy period.

**EVERY 10,000 MILES (16,000 Km.)****Universal Joints**

Lubricate the universal joints. The front joint is best lubricated from above, through the hole in the propeller shaft tunnel, at a point between the two front seats.

The rear joint must be lubricated from below. Move the car to bring the ripples to the required positions.

Also test the flange bolts and tighten if these have worked loose; the nuts are secured with tab washers.

**Clutch Operating Shaft**

Lubricate the two nipples sparingly.

**Sparking Plugs**

Renew the sparking plugs, Champion N.5B. Long Reach for the Saloon and Champion N.A.8 Long Reach for the Sports.

**Dynamic Bearings**

Unscrew the wick type lubricator cover and if the wick is dry refill the cup with high melting point grease.

*Note.*—From engine No. 857519 (Saloon, Coupé and Commercial) and engine No. 817406 (Sports) the wick type lubricator has been dispensed with. Instead, a hole has been drilled in the end cap through which a few drops of oil (S.A.E. 20) should be forced every 6,000 miles.

**"SPORTS" REGULAR ATTENTIONS**

The following list of attentions is of those which cover components or accessories not common to the Saloon. All other attentions should be carried out as previously recommended.

**EVERY 2,000 MILES (3,200 Km.)****Air Cleaners**

The air cleaners should be dismantled and the elements thoroughly cleaned with the aid of compressed air, see page C/12. If an element has become contaminated with oil or grease it should be thoroughly washed in petrol and allowed to dry before being replaced.

**Carburettors**

Remove the knurled cap at the top of each carburettor and add a few drops of oil to the suction piston chambers.

**EVERY 5,000 MILES (8,000 Km.)****Carburettors**

The flow of fuel at the carburettor inlet unions to the float chambers should be checked, and if necessary the filters in these unions should be cleaned.

Disconnect the float chamber fuel supply pipes (when the filters may be taken out and cleaned), slacken the float chamber cap nuts and unscrew their securing bolts. The chambers themselves can then be removed for cleaning.

**EVERY 10,000 MILES (16,000 Km.)****Carburettors**

Clean out the suction assembly by removing the two securing screws and lifting off the body in the same plane to avoid damage to the needle.

Lift out the hydraulic damper and wash the assembly in petrol. Dry thoroughly, refit and replenish the damper with oil. When fully re-assembled, lift the piston to its fullest extent thus expelling the surplus oil through the top cap and at the same time lubricating the rod.

**Air Cleaners**

Remove the top caps and renew the elements.

**SERVICE ATTENTIONS**

The following additional inspections and adjustments should be carried out periodically by an Austin Dealer at the mileages mentioned. These attentions are not usually carried out by normal owner drivers and the tools supplied in the Tool Kit are not sufficient for the work entailed.

**EVERY 5,000 MILES (8,000 Km.)****Decarbonising, Valve Grinding and Tappet Adjustment**

This attention may not be needed so frequently on cars used for long journeys. As a general rule, a falling off in engine power with pinking indicates when decarbonising is due.

This operation entails such preliminary dismantling of components as the carburetter, manifolds, cylinder head and push rods. The correct valve clearance, measured between the rocker arm and the valve stem, is .015in., with the engine hot or cold.

**Shock Absorbers**

All the shock absorbers fitted to the A40 models, with the exception of the A40 Sports fronts, are of Armstrong manufacture. Check the fluid levels and top up if necessary. The correct level is just below the filler plug threads. Carefully clear away all road dirt and grit from the vicinity of the filler plug before removal. Use only Armstrong Super (Thin Shock Absorber Oil).

Coiling shock absorbers are fitted to the A40 Sports front suspension. They must be removed from the chassis before inspecting the fluid levels or topping up with Coiling Piston Type Thin Fluid.

**EVERY 6,000 MILES (9,600 Km.)****External Oil Filter**

Take off the old filter and replace it with a new unit. Use only "A.C. Splanx" type ARIC or Purostat Micromic type MJ-2000.

**EVERY 10,000 MILES (16,000 Km.)****Contact Breaker Points**

Clean the contact breaker points. Cleaning of the contacts is made easier if the contact breaker lever, which carries the moving contact, is removed. To do this, slacken the nuts on the terminal post and lift off

the spring, which is slotted to facilitate removal. Before replacing, smear the pivot on which the contact breaker works, with clean oil.

Check the contact breaker setting, re-set if necessary. The correct gap is .014 - .016in.

**Starter Commutators**

Clean, also check the freedom of the brushes within the holders.

**Track Adjustment**

Check the front wheel alignment.  $\frac{3}{16}$  -  $\frac{1}{2}$ in. toe-in taken along a horizontal line at centre height using the wheel, rims as datum points.

**Steering Box**

Check for wear. This may be felt when the front wheels can be moved without creating any movement of the steering wheel.

**Clutch Pedal Clearance**

Check and adjust if necessary. The pedal should be depressed approximately  $\frac{1}{2}$ in. before the clutch springs are felt to be under compression.

**Oil Sump**

Remove and clean the sump, also the oil pump strainer gauze.

**Front and Rear Hub Bearings**

Check for any signs of wear. Details for this operation are given in Sections H and K.

**Ignition Timing**

Check the setting and adjust if necessary.









# INSTRUMENTS AND CONTROLS

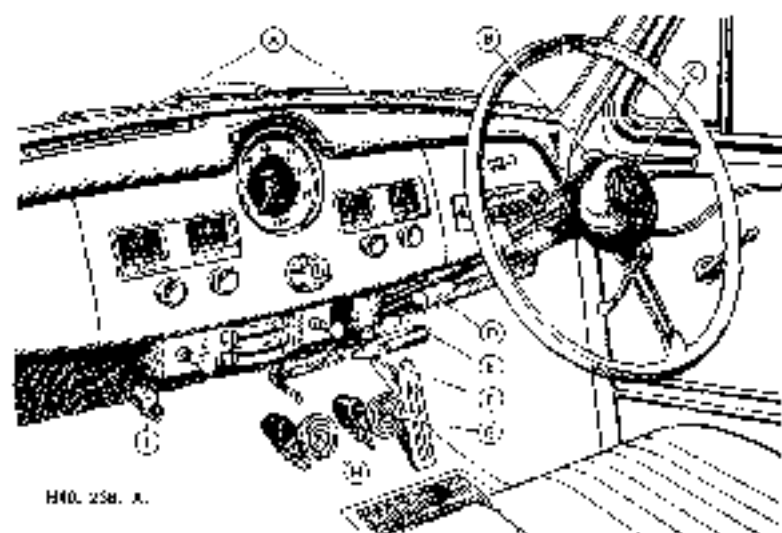

Fig. 1. Driving Controls (Saloon and Coupe).

- A. Dewisting vents.
- B. Trafficator switch.
- C. Horn Button.
- D. Gear lever.
- E. Handbrake.
- F. Accelerator pedal.
- G. Brake pedal.
- H. Clutch pedal.
- I. Dip switch.

## INSTRUMENTS

### Speedometer

Registers the vehicle speed and the total mileage. The trip figures at the top of the speedometer can be set to zero by pushing in the spring loaded knob on the right-hand side of the heater control in the case of the A40 saloon. The trip control in the A40 Sports is situated on the right-hand side of the Steering Column on the lower edge of the fascia.

### Oil Pressure Gauge

Indicates the oil pressure in the engine. It does not show the quantity of oil in the sump.

### Ammeter

Indicates the flow of current into or out of the battery. With the automatic voltage control system little or no charge is shown when the battery is fully charged.

### Ignition Warning Light

Glowes red when the ignition is switched "on" and fades out when the dynamo is charging the battery.

### Headlight Beam Warning Light

A red glow appears when the headlights are switched on, with the two beams full ahead. The light goes out when the headlights are dipped.

### Fuel Gauge

Indicates the contents of the tank when the ignition switch is on. When the tank is being filled, switch off and stop the engine. Switch on again and the needle will record the amount of fuel entering the tank.

### Water Temperature Gauge

This records the temperature of the cooling water circulating in the cylinder block and radiator. The correct operating temperature under normal conditions should not be below 164° F. (73.3°C).

## FOOT CONTROLS

### Accelerator

The right pedal.

### Brake

The centre pedal which operates the hydraulic brakes on all four wheels.

### Clutch

The left pedal. Do not rest the foot on this pedal when driving or hold the clutch out to "free wheel".

### Dip-switch

If the headlights are on full, a touch on the foot dip-switch alters the lights to the "dipped" position and they remain so until another touch returns them to full "on."

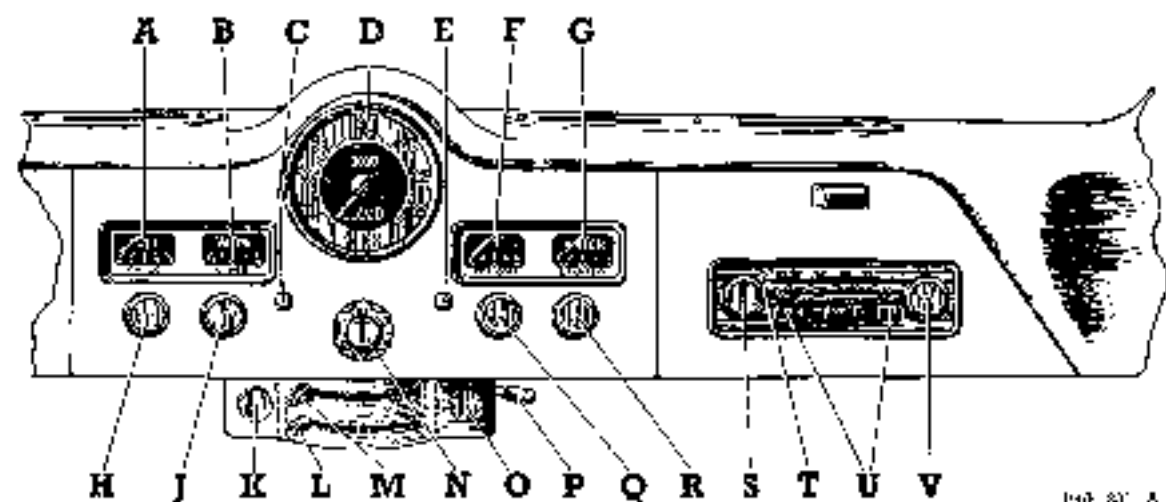

Fig. 2. Fascia panel (Saloon)

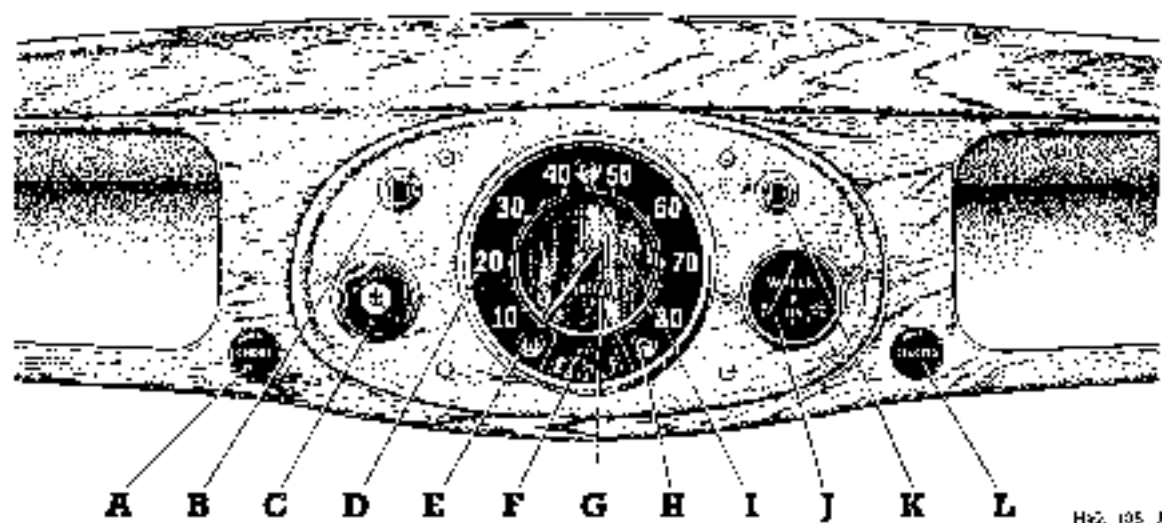

Fig. 3. Fascia panel (Commercials)

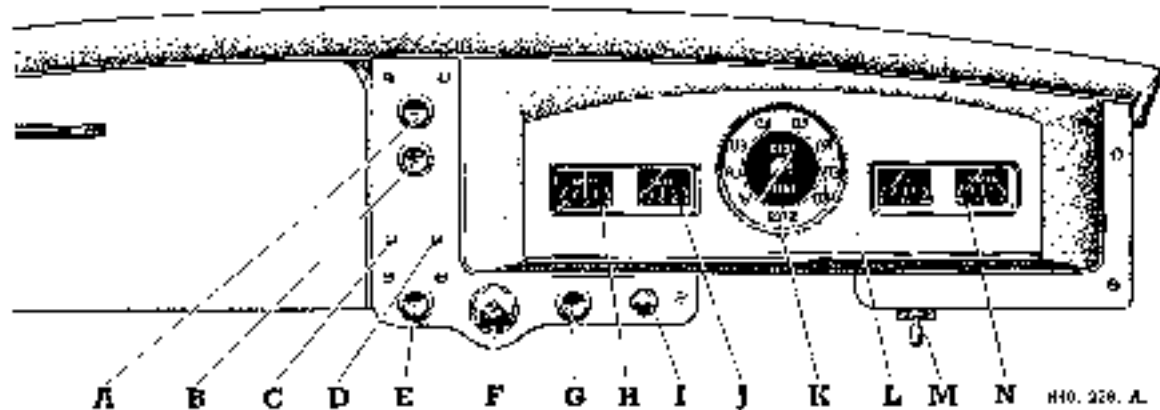

Fig. 4. Fascia panel (Sports)

Caption for Fig. 2.

- |                                  |                                  |                              |
|----------------------------------|----------------------------------|------------------------------|
| A. Fuel gauge.                   | H. Choke control.                | P. Speedometer trip control. |
| B. Ammeter.                      | I. Windscreen wiper control.     | Q. Panel light switch.       |
| C. Headlight beam warning light. | K. Extra oil control.            | R. Starter control.          |
| D. Speedometer.                  | J. Air control.                  | S. Radio cutoff switch.      |
| E. Ignition warning light.       | M. Demister/defroster control.   | T. Tone control.             |
| F. Oil pressure gauge.           | N. Ignition and lighting switch. | U. Tuning push-buttons.      |
| G. Water temperature gauge.      | O. Heater motor switch.          | V. Manual tuning control.    |

Caption for Fig. 3.

- |                                  |                                |                                  |
|----------------------------------|--------------------------------|----------------------------------|
| A. Choke control.                | F. Oil pressure warning light. | I. Headlight beam warning light. |
| B. Windscreen wiper switch.      | G. Fuel gauge.                 | J. Water temperature gauge.      |
| C. Ignition and lighting switch. | H. Mileage recorder.           | K. Panel light switch.           |
| D. Speedometer.                  | H. Ignition warning light.     | L. Starter control.              |

Caption for Fig. 4.

- |                                  |                                  |                              |
|----------------------------------|----------------------------------|------------------------------|
| A. Windscreen wiper control.     | F. Ignition and lighting switch. | K. Speedometer.              |
| B. Panel light switch.           | G. Choke control.                | L. Oil pressure gauge.       |
| C. Headlight beam warning light. | H. Ammeter.                      | M. Speedometer trip control. |
| D. Ignition warning light.       | I. Heater motor control.         | N. Water temperature gauge.  |
| E. Starter control.              | J. Fuel gauge.                   |                              |

## HAND CONTROLS

**Hand Brake**

Pistol grip type situated under the fascia and secured to the left side of the Steering Column. Operates mechanically on the rear wheels only.

**Gear Lever**

Should always be in neutral when starting the engine. The lever is mounted on the left side of the Steering Column. To engage a gear, depress the clutch and move the lever to the required position as described on page A-7.

**Choke Control**

For use when starting the engine from cold. Pull out to the first until the engine fires and return it to the

half-way position for rapid warming up. The choke must be fully pushed in at the earliest possible moment.

**Ignition Switch**

Turn the key in a clockwise direction to switch on. Do not leave the switch "on" when the vehicle is stationary—the warning light is a reminder. The ignition key may also be used for locking the driver's door and the luggage boot.

**Lighting Switch**

This is the centre moulding which surrounds the ignition switch. Turn clockwise to the first notch to put on the sidelights and in the second notch to put on the headlights. The headlights are dipped by foot operation.

Fig. 5. Driving controls (Sports)

- |                       |
|-----------------------|
| A. Demisting vents.   |
| B. Tractioner switch. |
| C. Horn button.       |
| D. Bonnet release.    |
| E. Axle crator pedal. |
| F. Handbrake.         |
| G. Brake pedal.       |
| H. Clutch pedal.      |
| J. Gear lever.        |
| K. Dip switch.        |

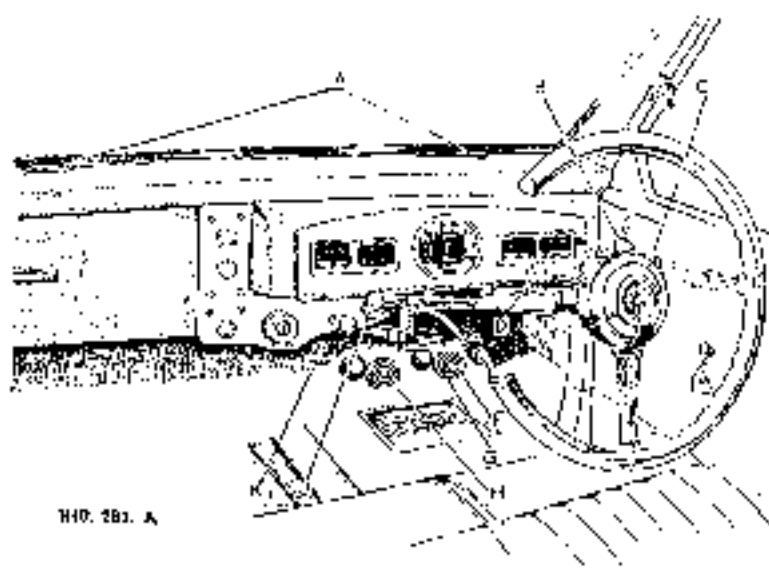

H10. 281. A

### Starter Control Knob

Pull out the knob to start and release as soon as the engine fires. If the engine fails to start after a few revolutions, do not operate the starter again until the engine is stationary.

### Heater Controls (Saloon and Coupé)

These are situated centrally below the fascia and provide the means for regulating the heating and demisting system. Full operating instructions are given on page P/10.

### Heater Control Switch (Sports and Commercial)

Turn to the right until a click is heard. This starts the heater fan. The further the control is turned the faster will be the speed of the fan, due to the fact that a rheostat is incorporated.

### Windscreen Wipers

To start the electric wipers pull out the wiper control. To park, switch off by pressing the control inwards when the arms are at the end of the stroke. Do not try to push the arms across the windscreen by hand.

### Panel Light Switch

Pull out the switch control knob to illuminate the instruments. Only operates when the sidelights are on.

### Bonnet Opening (Saloon and Coupé)

To open the bonnet first lift the "Flying A" motif on the bonnet top. By virtue of its tipping forward, the bonnet is unlocked and can be lifted a sufficient amount to enable the operator to put the fingers of his free hand between the bonnet and cover panel and so push back the safety catch.

A stay, held to the underside of the bonnet by a rubber clip, can be swung down from the bonnet to rest

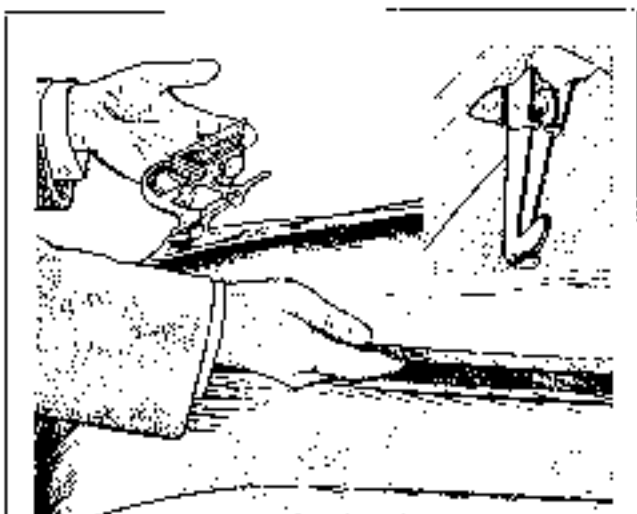

Fig. 6. Lifting the motif to open the Saloon bonnet. Inset illustrates the safety catch.

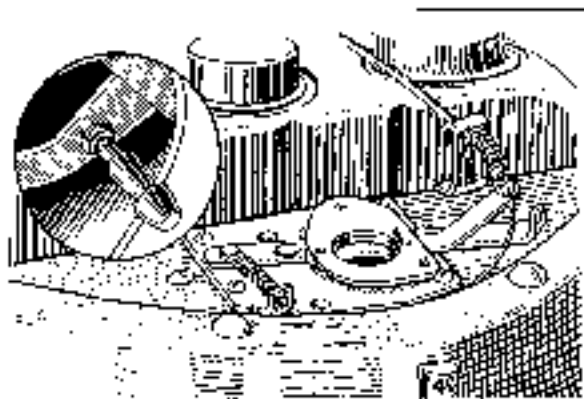

Fig. 7. Showing the mechanism of Sports bonnet catch with metal cone on the bonnet top.

in the cup provided on the top of the radiator, thus securing the bonnet in the open position.

### Bonnet Catch (Sports)

To open the bonnet, pull the control handle, situated beneath the fascia. The bonnet will rise approximately an inch and will then be held from opening fully by a safety catch. This catch acts on the lower of the two cones on the locking peg which is secured to the bonnet top. The safety catch is designed to hold down the bonnet in the event of the bonnet not having been properly locked.

Insert the fingers and push back the safety catch, then raise the bonnet fully. In the open position the bonnet is secured by a telescopic stay, bolted to the underside of the bonnet and the scuttle. To close the bonnet raise it slightly to release the stay catch, lower the bonnet and extend a slight pressure on the bonnet top until the catch is heard to engage.

### Trafficators

These are controlled from the centre of the steering wheel. Normally, after the vehicle has turned a corner they return automatically, but when only a slight turn has been made it may be necessary to return them manually with the switch.

### Horn Control

This control is mounted in the centre of the steering wheel and operates independently of the ignition switch.

### Sliding Roof

Turn the handle clockwise and fully unlock the roof before opening. Any attempt to open the roof without unlocking it will seriously damage the mechanism.

### Interior Light

Combined with a switch in the rear.

### Spare Wheel

For the Saloon, Coupé and Sports the spare wheel is housed in the luggage boot. The Commercials have a separate compartment under the floor boards accessible through a panel at the rear of the vehicle.

### Front Seats

The close fitting front seats are adjustable, with ample backward and forward movement when the spring-loaded trigger (in front of the seat) is operated.

### Doors

The right hand side front door of all models in the A40 range are locked with the ignition key. The luggage boots of the Saloon and Sports and the rear doors of the Van and Countryman are also locked with this key. The remaining doors are locked by fitting the inside door handle.

### Hood (Sports)

To stow the hood first release all the press fasteners that secure the base of the hood to the body. Unfasten the rear seat squab centre retaining strap and pull the squab forward. Separate the rear window from the hood by releasing the five press studs, situated beneath a small flap at the top of the window, and stow it carefully away in the rear compartment. The two hood webbing straps must now be released and the hood rail lifted clear of its two securing pegs situated above the windscreen.

The hood can now be lowered, although while doing so it will be necessary to press inwards on the jointed rear hood support, in order to prevent it fouling the rear edge of the hood well.

Downward pressure must now be exerted on the hood top brackets in order to straighten them—this being most important if the hood is to take up its correct position in the well. Roll up the front part of the hood and stow

it as far back as possible in the hood well. It is essential that the whole hood assembly be pressed very compactly into the well provided, in order that the rear seat squab may be returned to its normal position and fastened. Finally replace the hood well side covers.

Raising the hood is an exact reversal of the above procedure.

The hood is best cleaned by vigorous brushing, when thoroughly dry, although if very dirty it is advisable to sponge it down lightly beforehand.

The Melloroid hood fitted to later models should be cleaned with soap and water solution applied with a fairly stiff brush. Excessive dirt may be removed with the aid of clear methylated spirits and a brush.

### Petrol Filler Cap

The filler cap is situated on the left-hand side of the body and has an anchor cable to prevent loss.

### Radiator Filler Cap

Screw type situated under the bonnet.

### Oil Filler Cap

Positioned at the rear of the valve rocker cover.

### Jacking

The manually operated jack is lowered into position through a panel in the floor—one at the side of each front seat—and when operated, raises the left or right side of the car.

In the case of the Sports the seat on the side to be lifted will have to be moved to the rear. The wheelbrace is used to operate the jack.

A screw type jack is supplied with the Van, Countryman and Pick-up.

### Radio (Saloon and Coupé)

The radio, where fitted, is a Radiopolite Model No. 4200 operated via flexible cables by controls mounted on the fascia immediately before the driver. The loud-speaker is located centrally in the roof canopy above the windscreen and hidden from view by the roof lining.

To switch on the receiver, turn the small central knob, on the left of the push buttons, in a clockwise direction. Progressive rotation of this control increases the volume as required. The larger control concentric with the ON/OFF switch provides four separate tone settings; anti-clockwise for speech and clockwise for music.

Manual tuning is obtained with the control on the right of the push buttons and provides complete variable station selections. The knob will not, however, engage the tuning mechanism until pressed inwards as this prevents accidental disturbance of a station previously selected by a push-button. This knob will then remain in engagement

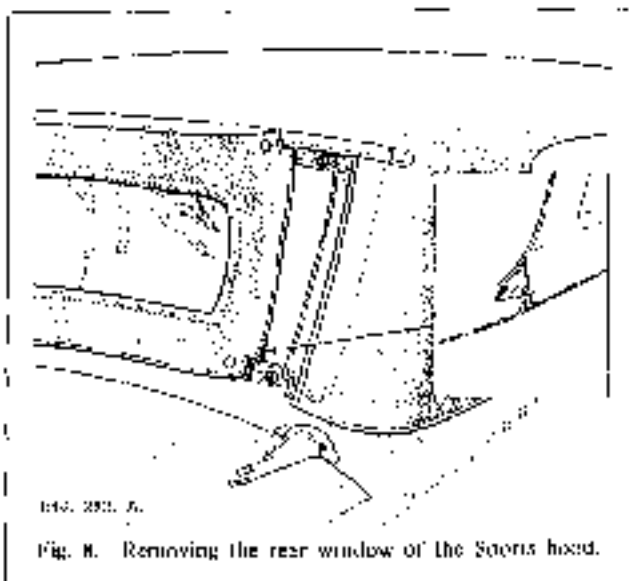

Fig. 8. Removing the rear window of the Sports hood.

for manual tuning until it is automatically returned by pressing inwards one of the push-buttons.

The tuning scale is divided into two sections, medium wave and long wave, and either may be selected for open manual tuning by pushing inward either the medium wave or the long wave button as desired.

Five tuning push-buttons provide automatic tuning for one long and four medium wave band stations. All push-buttons may be easily reset to any medium or long wave station to suit individual requirements. (See "Radio" in Bodywork.)

The external aerial should be extended prior to using the set, and it is recommended that it is retracted when not in use.

### STARTING

Before starting the engine check the oil level in the sump and the water level in the radiator. The oil sump dipstick is on the right hand side of the crankcase and the water level should be just below the top of the radiator filler plug thread. Also check that there is fuel in the tank.

See that the gear lever is in neutral and then, if the engine is cold, pull out the choke control. In very cold weather the engine should first be rotated several times with the starting handle.

Pull the starter knob firmly. Release again if the engine fails to start promptly. Allow a short interval between each attempt to start and if the engine does not fire in a reasonably short time look for the cause.

Never pull the starter knob unless the engine is stationary.

As soon as the engine starts release the choke to the half-way position for rapid warming-up. Do not use the accelerator while the choke is out, but push in the choke completely as soon as the engine will run without it.

In very cold weather depressing the clutch pedal when starting the engine will relieve the battery of excessive strain by disconnecting the gearbox from the clutch.

When the car has been parked for some time the fuel in the carburettor may have evaporated. Before attempting to start the engine, refill the carburettor by operating the hand-priming lever on the fuel pump. This will prevent an excessive strain on the battery through too much use of the starter.

The pumping action should be distinctly felt until the carburettor bowl is full. If the pumping action cannot be felt turn the engine with the starting handle about one full turn when the priming lever should be free to pump.

Do not race the engine when first started as time must be allowed for the oil to circulate properly. Let the engine idle fairly fast for a few minutes before moving off, or engage top gear as soon as possible after starting. Blanking off the radiator will assist the engine to warm up quickly, but always uncover the radiator before moving. A thermostat is incorporated in the cooling system to assist rapid warming up.

### DIFFICULT STARTING

Failure of the engine to start may be due to one or to a combination of any of the following:

- (a) Ignition switched off.
- (b) Lack of fuel at the carburettor due either to an empty tank or to a fault in the fuel pump. This fault can be localised by disconnecting the inlet pipe union to the carburettor and operating the fuel pump hand priming lever. If the fuel pump is in order fuel will escape from the loose union.
- (c) Ineffective operation of the pump may be due to a choked filter gauze, an air leak in the pump or to a mechanical fault in the pump. The servicing of the fuel pump is fully described in section C.
- (d) No spark at the plug points due to:
  - (i) Badly fitted, dirty or incorrectly set Contact Breaker points.
  - (ii) Faulty capacitor causing the excessive pitting of the points in (i).
  - (iii) A faulty ignition coil.
  - (iv) An open circuit in the low tension ignition circuit as can be tested by connecting a 12-volt bulb between the low tension terminal on the distributor and an earth point on the chassis. The bulb should light when the ignition is switched on. Failure of

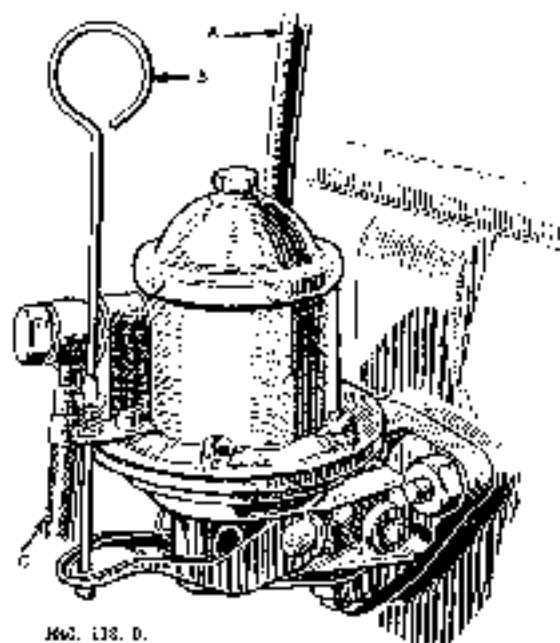

REV. 138. D.

Fig. 9. The fuel pump.

A. Delivery pipe. B. Priming lever. C. Supply pipe.



the bulb to light indicates a break in the ignition circuit from the battery to the distributor. This may be due to a poor terminal connection or to a burnt out coil.

By connecting the test lamp bulb between earth and other low tension points in the distributor, the flow of the ignition current can be accurately traced as far as the earthed contact breaker point.

Alternatively a quick general check, as to whether the low tension ignition circuit is in order, can be obtained by watching the ammeter needle when the ignition is switched on and the engine is turned slowly by hand. If the circuit is in order the ammeter needle will flicker as the contact breaker points open and close.

(v) A poor connection between the high tension cable terminal in the distributor cap and the distributor rotor arm

(vi) Dirty, sooted or oiled-up plugs.

## DRIVING

The following speeds should not be exceeded during the first 500 miles.

1st	2nd	3rd	Top
7	12	18	30 m.p.h.

The gearbox has four forward speeds and a reverse.

To engage first gear, move the gear lever towards the fascia and then upwards. Engaging second gear is achieved by moving the gear lever steadily downwards through neutral to the next gear. For third gear move the lever upwards into neutral, then towards the steering wheel, and finally upwards into third. Top gear is gained by the lever being brought downwards, parallel to the steering wheel, through neutral into the last gear position.

To engage reverse, move the lever towards the fascia as far as it will go, at the same time pulling outwards on the knob on the end of the lever and then move the lever downwards.

If when the clutch is let in the car does not move it will mean that there has been no proper engagement of the gear. Decutch again when it will be found that the gear lever may be moved forward to give the correct engagement. Never use force, but always move the gear lever as far as it will go.

When the car is travelling at about 7 m.p.h. engage second gear. Engaging a higher gear is effected by decutching, moving the gear lever steadily through neutral to the next gear and then letting in the clutch smoothly. The accelerator must be depressed gently as the clutch is let in to ensure the drive is taken up smoothly.

Engage third gear at approximately 12 m.p.h. and top gear at approximately 18 m.p.h.

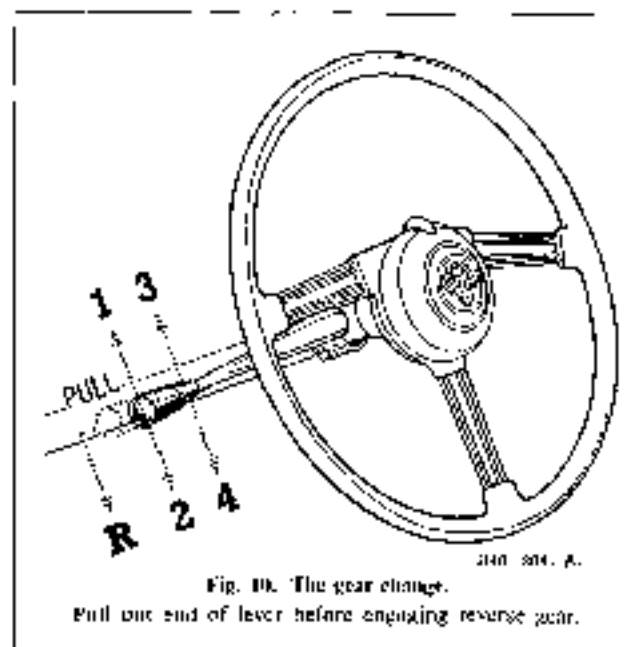

When changing down a smoother gear change is made if the accelerator is kept depressed to provide the extra engine speed to suit the lower gear.

Never engage reverse gear unless the car is stationary.

Gear changing may be slightly stiff in a new vehicle until the moving parts have eased in use. Changing should therefore be done deliberately but not hurriedly.

Always change down early on a hill since the engine will not be able to pick up speed if the car has almost stopped. Third gear should be engaged when the car's speed falls below 20 m.p.h. in top gear.

Keep the foot off the clutch pedal except in heavy traffic or excessive wear of the clutch linings and carbon release ring will result. Even when driving in heavy traffic the weight of the foot should not be taken by the clutch pedal.

Engage low gear when descending a steep hill and leave the clutch engaged, as the engine will then serve as a very effective brake.

When braking, use the pedal and leave the clutch in, only disengaging it at the last moment before stopping. The handbrake should only be used when parking the car, negotiating traffic, or when starting away on a hill.

Always apply the footbrake progressively to secure the required retardation. Fierce braking is bad for the car, wears the tyres excessively and on a wet or icy road is very dangerous.

After the car has been washed or driven through water, dry out the brakes by gently applying them for some distance. Keep the handbrake hard on when the car is being washed.







# COOLING SYSTEM

An efficient cooling system is of major importance to ensure the satisfactory running of the engine and it is therefore necessary to pay particular attention to its maintenance. Attention is especially drawn to the procedure advised for the winter months, if damage to the unit is to be avoided.

## Description

The cooling system is maintained by water pump circulation combined with an efficient fan-cooled radiator and thermostat.

The radiator incorporates an expansion chamber, which prevents the loss of water. When under operation the cooling water expands and rises, thus filling the expansion chamber.

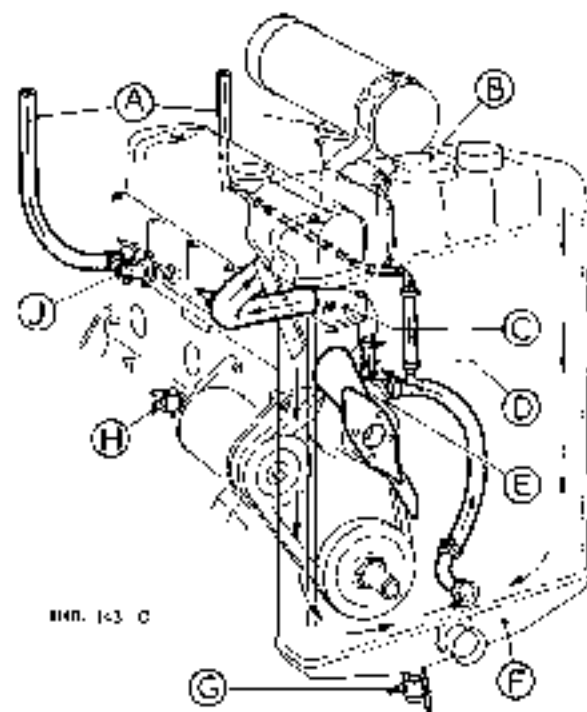

Fig. 1. The cooling system.

A. Heater pipes. B. Filler cap. C. Thermostat. D. By-pass pipe. E. Water pump. F. Radiator bottom tank. G. Radiator drain tap. H. Cylinder block drain tap. I. Control valve (Sports and Commercial vehicles only).

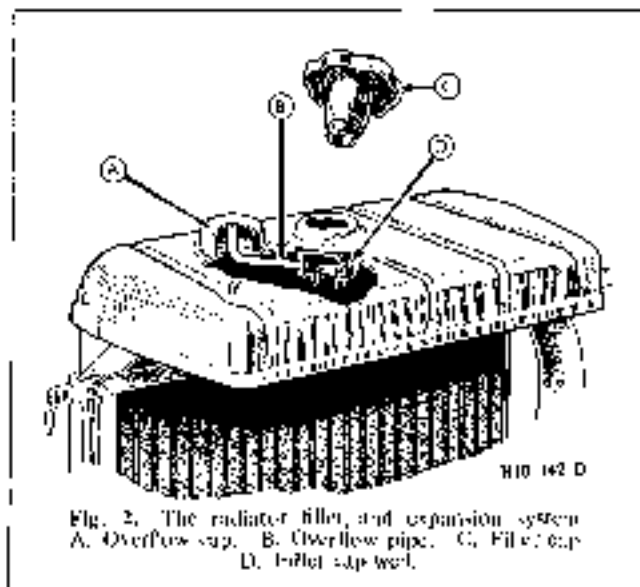

Fig. 2. The radiator filler and expansion system. A. Overflow cup. B. Overflow pipe. C. Filler cap. D. Filler cap well.

when the engine is cold. The total capacity of the cooling system is 12 pints (Saloon) and 14 pints (Sports).

## Thermostat

In order to ensure maximum engine efficiency, it is essential to keep the engine operating temperatures within certain limits. To assist this, a Smith's bellows thermostat is fitted, being located in the water outlet at the front of the cylinder head. The device consists of metallic bellows, filled with a volatile liquid, which control a mushroom valve. When the engine is cold this valve is closed, a by-pass being fitted to allow for slight circulation. On starting the engine the flow of water to the radiator will be temporarily restricted. Due to this the temperature of the water in the cylinder jackets will quickly rise, thus causing rapid warming up. The heat so generated will gradually expand the bellows so opening the valve, and ultimately permitting full flow to the radiator.

The thermostat itself is detachable; therefore, should occasion arise, it can be removed from its housing and the hose reconnected to avoid laying up the car. Should the thermostat be tight there are two tapped holes on the top which may be utilised to ease it from the casting.

When the system has been completely emptied, it is essential to wait a minute or two after refilling to allow air to escape through the thermostat valve and then finally top up.

The displaced air resulting from this, escapes through a small overflow pipe connecting the top of the chamber with the bottom of the filler plug well. Should any further expansion take place, the water flows along this overflow pipe to the filler plug well, being drawn back into the radiator when the engine cools.

Topping up is only necessary very occasionally, to replace water lost through evaporation. Use only rain water if available, or alternatively clean, soft water, and fill to just below the top of the filler plug thread

The thermostat opening is set by the manufacturer and cannot be altered. It opens at a temperature of 65-70 deg. Centigrade. During decarbonising it is policy to test this opening by immersing the thermostat in water raised to the requisite temperature. The valve should open under these conditions, but if it fails to open, a new unit should be fitted.

### Overheating

Overheating may be caused by a slack fan belt, excessive carbon deposit in the cylinders, running with ignition too far retarded, incorrect carburettor adjustment, failure of the water to circulate, or loss of water.

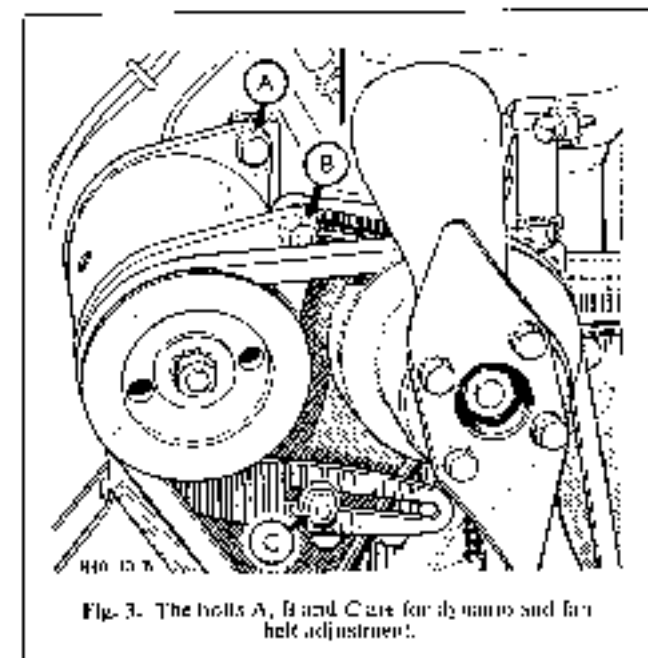

A muff can be used to advantage, but care must be taken not to run the car with the muff fully closed, or huffing will result.

### Anti-freeze Solution

Vehicles with anti-freeze mixture in the cooling system should have an identification mark on the header tank of the radiator, under the bonnet, in the form of a disc painted in a specified colour.

The following precautions are necessary on vehicles so marked:—

1. When frost is expected or when the vehicle is to be used in a very low temperature, make sure that the strength of the solution is, in fact, up to the strength ordered by the manufacturers.

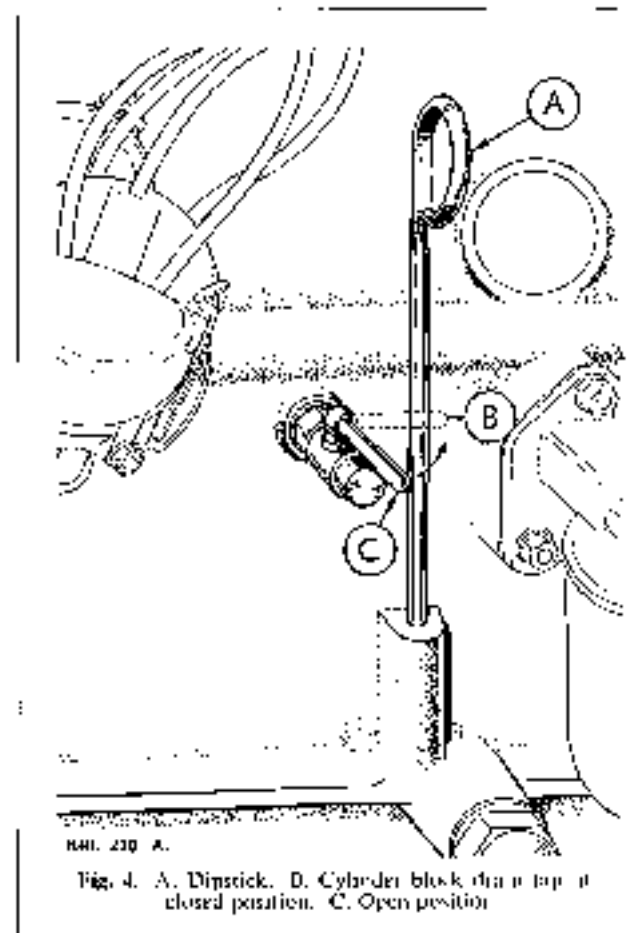

### Fan Belt Adjustment

The fan is driven from the crankshaft by a "V" belt, this also driving the dynamo. A new belt can be fitted by first loosening the clamp bolts (A, B and C) Fig. 3, which hold the dynamo in position and moving the dynamo towards the engine. Slide the belt over the fan on to the fan pulley, the crankshaft pulley, and finally on to the dynamo pulley. Adjustment is then made by bringing the dynamo away from the engine. The belt should be sufficiently tight to prevent slip, yet it should be possible to move the belt laterally about one inch each way. As the drive is taken on the "V" of the pulleys it is not necessary to have the fan belt tight; to do so may cause excessive wear to the dynamo and water pump bearings. After the correct tension has been obtained, securely lock the dynamo in position again.

### FROST PRECAUTIONS

Freezing may occur first at the bottom of the radiator or in the lower hose connection. Ice in the hose will stop water circulation and may cause boiling.

2. The strength of the solution must be maintained by topping up with anti-freeze solution as necessary. Excessive topping up with water reduces the degree of protection afforded. Solution must be made up in accordance with instructions supplied with the container.
3. Top up when system is cold.
4. If the cooling mixture has to be emptied, run the mixture into a clean container and use again.



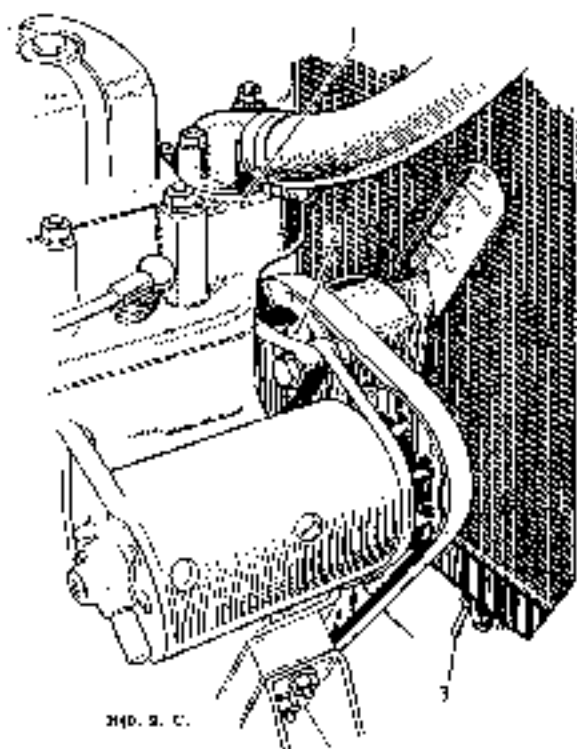

Fig. 6. 1. Thermostat housing. 2. Lubrication plug. Lubricate sparingly with oil, using the oil gun.  
1. Radiator drain tap.

before it can be tapped out. See Fig. 7. It will be followed by the oil retaining assembly, consisting of a dished steel washer, a felt seal and an oil retaining ring.

#### Sealing Ring Assembly

The sealing ring assembly consists of a gland spring, a metal locating cap, a rubber washer, a carbon sealing ring and a distance piece. The impeller is screwed on to the spindle, then riveted in position.

#### Reassembly

When reassembling, it is essential that the bearings, distance pieces, various washers and other parts are correctly positioned. Fig. 5 shows the correct order. It is also important that the gland spring is holding the carbon seal against the pump body. This can be ascertained by checking the free length of  $\frac{3}{8}$ -inch (2.38 cm).

#### Refitting the Fan Blades

The shaped blades of the fan must be fitted with the convex or arched side facing the radiator. If fitting is reversed, the engine will tend to overheat.

#### Removing and Dismantling the Unit

Drain the water from the radiator. Remove the pump unit from the cylinder block by taking off the fan belt and releasing three set-pins with spring washers from their studs together with the hinge bolt and washer to the dynamo. Disconnect the bottom hose and the by-pass hose from the pump body.

Remove the fan blades if necessary by withdrawing the four screws from the pulley.

#### Removing the Pump Spindle

Remove the nut from the front end of the spindle, withdraw the fan pulley and take out the key.

Take the spindle complete with impeller spring and seal assembly through the rear of the pump body.

While holding the pump body, the spindle can now be tapped out towards the rear, carrying with it the impeller, spring and sealing ring assembly.

#### Bearings and Washers

The two ball bearings, distance piece, steel and felt washers have next to be removed from the body. First, prise out the spring ring and remove the oil retaining ring; then, using the water pump bearing drift (Service Tool 18G 60, see page Q.1), tap out the first bearing, which will be followed by the tubular distance piece. The second bearing must be centralised in the body

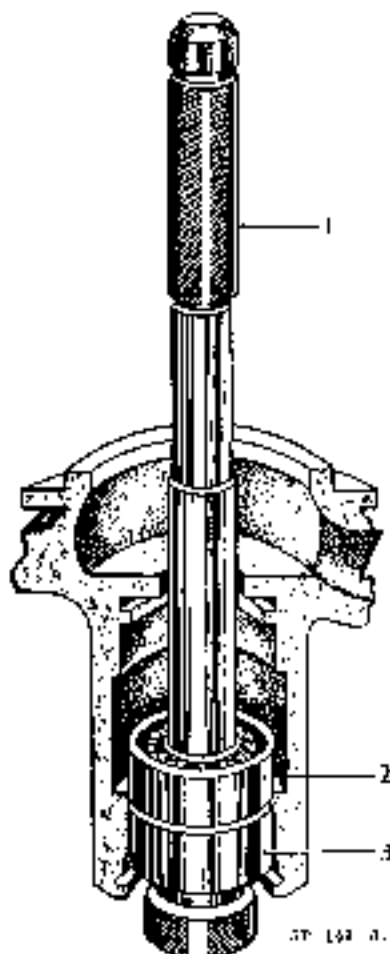
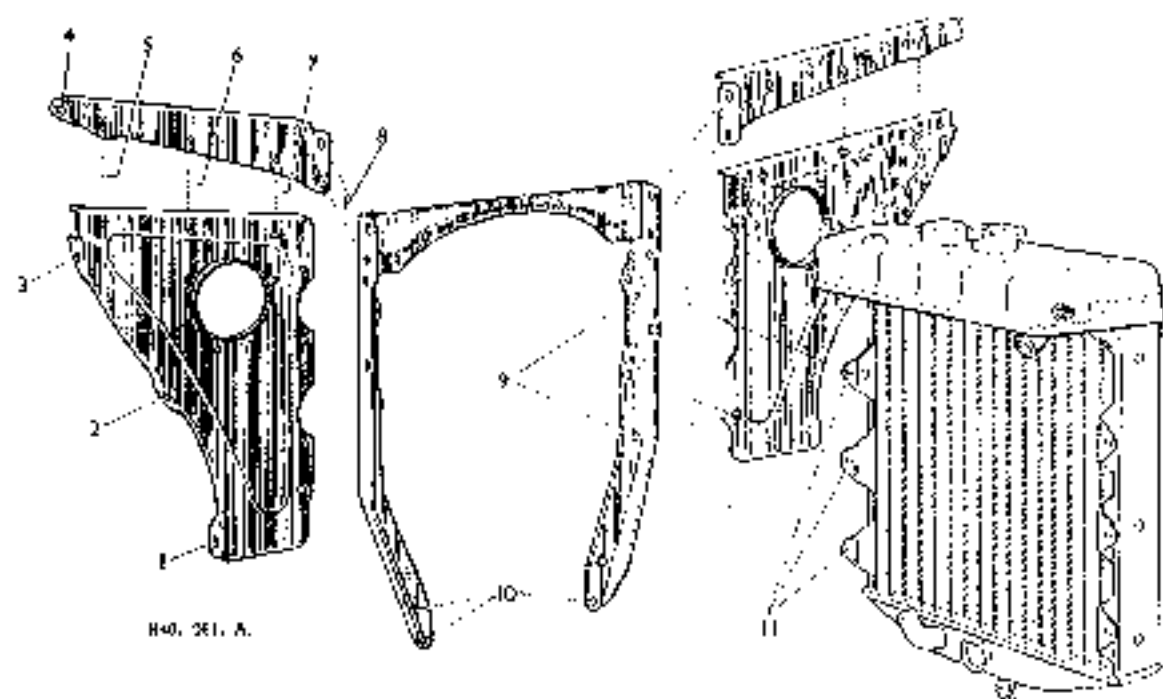

Fig. 7. Removing rear bearing, using Service Tool 18G 60. 1. Drift. 2. Rear bearing. 3. Dummy bearing.



## REMOVING THE RADIATOR



H40, 261, A.

Fig. 8. Radiator and mounting frame (Saloon)

1-4. Fitch plate securing points. 5, 6 and 7. Points for securing together the upper and lower extension frames. 8. Upper extension to main frame fixing positions. 9. Lower extension to main frame fixing positions. 10. Main frame to chassis securing points. 11. Radiator to frame fixing points. Note. Upper and lower extension frames not fitted to the Commercial vehicles.

## Saloon

The radiator is frame mounted and secured in position by six bolts, three either side, with nuts and washers. The frame is held by nuts and bolts and by setpins to the bodywork and chassis. In normal servicing it is not necessary to remove the radiator mounting frame.

To remove the radiator, first drain the water from the system and then, from beneath the bonnet, release the upper water hose from the radiator header tank and the thermostat housing. To effect this removal, slacken the hose clip screws at either end of the hose with the aid of a screwdriver and then ease the rubber pipe off both the radiator and thermostat housing connections. In a similar manner release the lower water hose from the water pump. The temperature gauge bulb should now be removed from the radiator.

Next release the three securing bolts, at each side of the radiator (see Fig. 8), with nuts and washers, that hold the radiator to its mounting frame. The radiator may now be lifted clear of the car.

When replacing the radiator, reverse the removal sequence of operations and top up with water or the requisite mixture of water and anti-freeze solution.

## Sports

**Method 1:** First drain the cooling system by means of the radiator and cylinder block drain taps. If anti-freeze solution is present this may be collected in a clean receptacle and used again. Disconnect top and bottom hose. Remove the temperature gauge bulb from the radiator header tank and unlatch the socket lock control cable from its catch, situated just in front of the radiator top.

Dismantle both horns from their brackets by undoing the four nuts and bolts. Disconnect the leads from each horn, having first removed their covers. Break the snap connectors on the left-hand side and then release the cable harness from the radiator mounting frame by undoing the three clips.

From under the wings, remove the top nut and bolt and the two setpins at each side which hold the radiator frame to the fitch plates. Withdraw, from beneath the car, the four setpins securing the radiator frame to the chassis front cross member.

With the fan blades turned horizontally, to save possible damage, the top of the radiator should be tilted towards the engine. The complete assembly can then be manoeuvred upwards and so clear of the car.

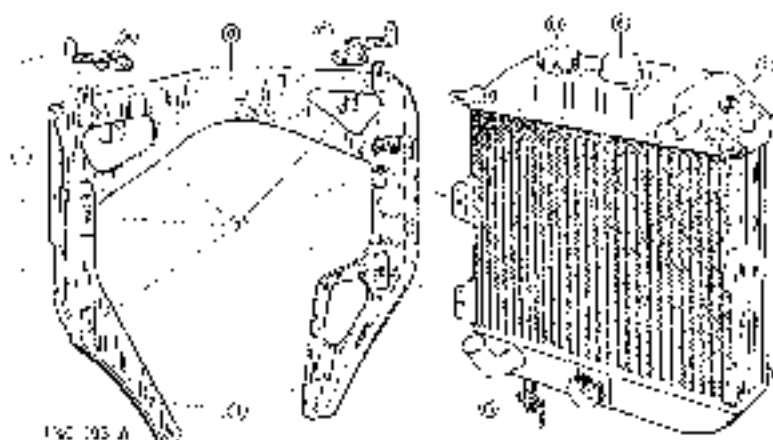

Fig. 9. Radiator and mounting frame (Sports)

- A. Right-hand horn bracket.
  - B. Radiator frame.
  - C. Left-hand horn bracket.
  - D. Filler cap.
  - E. Heater tank expansion chamber.
  - F. Thermometer bulb socket.
  - G. Drain tap.
1. Securing points to fitch plate.
  2. Radiator securing points.
  3. Setpins to chassis.

**Method 2:** Proceed as in the first paragraph of Method 1. Then, if there is no pit available, the front of the car should be jacked up and wooden trestles placed beneath the front wheels. Now remove the front bumper complete. To do this, unfasten the two brackets that hold the bumper to the chassis side members. On the steering gear side of the chassis the bumper bracket is held by two bolts, one long and one short, with nuts and washers, whereas on the other side the bracket is fixed by a short bolt, with nut and washer, and a long setpin.

Next disconnect the cross tube by withdrawing two split pins and removing the two castellated nuts, one from each end of the tube. At each side, the radiator is held to its frame by one bolt, with nut and washer, and two setpins. Remove these and carefully manoeuvre the radiator downwards and so clear of the car.

Refitting is a reversal of the above procedure, however, notice should be taken that it is advisable to check the track alignment once the refitting operations have been completed.





# FUEL SYSTEM

**A**LTHOUGH the two fuel systems (Saloon and Sports) are here described in detail, any measure of intricate servicing is best left to the expert.

The fuel tank has a capacity of 87 gallons (39.78 litres). In the Saloon, Coupé and Sports, the tank is secured by its upper flange to the floor of the luggage compartment. In the Commercial vehicles, the tank is located under the rear flooring. A lockable filler cap is fitted to each model.

An AC petrol pump, operated by the engine camshaft, draws fuel from the tank and forces it under pressure to the carburettors, a single Zenith for the Saloon and twin S.U. for the Sports. The two fuel systems are equipped with efficient air cleaners.

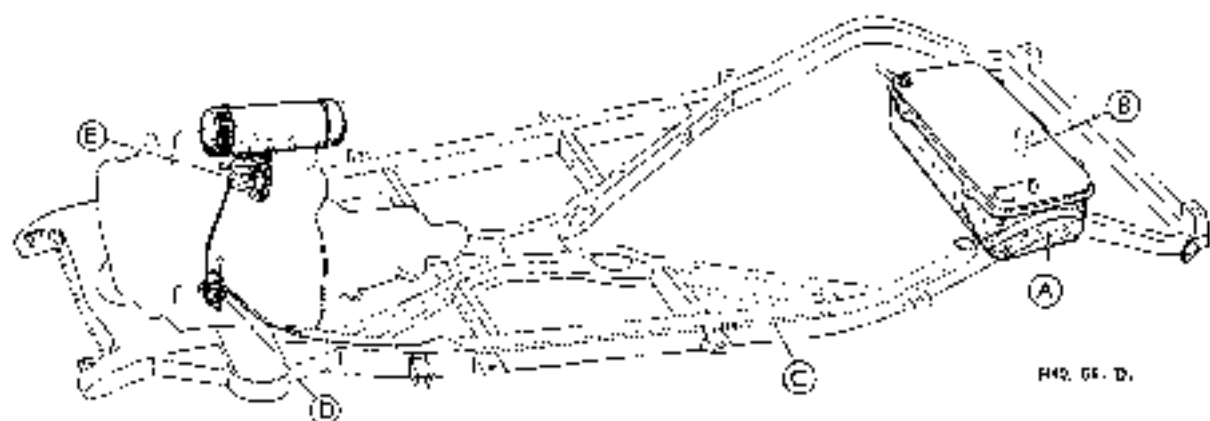

Fig. 1. The general layout of the fuel system (Saloon).

The Sports arrangement differs only, in the respect that twin S.U. carburettors are fitted and a different type of air cleaner. (A) the tank (B) electrical gauge unit (C) fuel pipe line (D) fuel pump (F) carburettor.

## PETROL TANK

### Draining the Tank

The drain plug is positioned on the left-hand side on the bottom of the tank and is removed for draining.

### Removing the Tank

Disconnect the petrol delivery pipe from the inner situated on the front face of the tank and to the left-hand.

Disconnect the insulated lead from the petrol gauge unit terminal at the rear of the tank.

Remove the spare wheel by releasing the securing setpin and in the case of the sports, take out the carpet. Slacken the filler hose clips, accessible from inside the luggage compartment, remove the hose and seal up the tank opening to prevent foreign matter entering the tank.

Disconnect the rubber overflow pipe from the tank and withdraw the five tank securing setpins. Three of these are situated on the front flange and two on the rear flange.

The tank can now be raised and lifted clear of the car through the luggage compartment. Take care not

to damage the composite sheeting fixed to the top of the tank.

The petrol tank in the Commercial is mounted similarly to the tank in the car, but access is gained by removing the rear flooring, held in position by countersunk screws, and the spare wheel.

### Replacing the Tank

Reverse the order for removing the tank.

### Petrol Tank Gauge Unit

This can be removed from the tank complete by the withdrawal of the six securing screws, but care must be taken not to bend or strain the float lever or subsequent gauge readings may be seriously affected.

Great care should be taken, when refitting the gauge unit, to see that the joint washer is in place. It is essential that a petrol tight joint should be made between the tank and the face of the unit. If there is any apparent damage to the washer it must be replaced by a new one.

## MANIFOLDS AND THROTTLE LINKAGE

### Manifolds (Saloon)

To remove the inlet and exhaust manifolds it is necessary to disconnect the air cleaner, carburettor controls, petrol pipe, vacuum timing control pipe and exhaust pipe.

Inlet and exhaust manifolds can be removed as one unit after releasing the two end nuts and four setpins with special clamping washers. Detach the manifold washer and if damaged replace on reassembly.

It will be noticed that the inlet and exhaust manifolds are separate castings. At the point where they are joined immediately below the carburettor flange a special design of "hot spot" is incorporated. The two castings are held in position by four setpins, together with a joint washer. Each manifold should be re-assembled to the engine separately and then secured together.

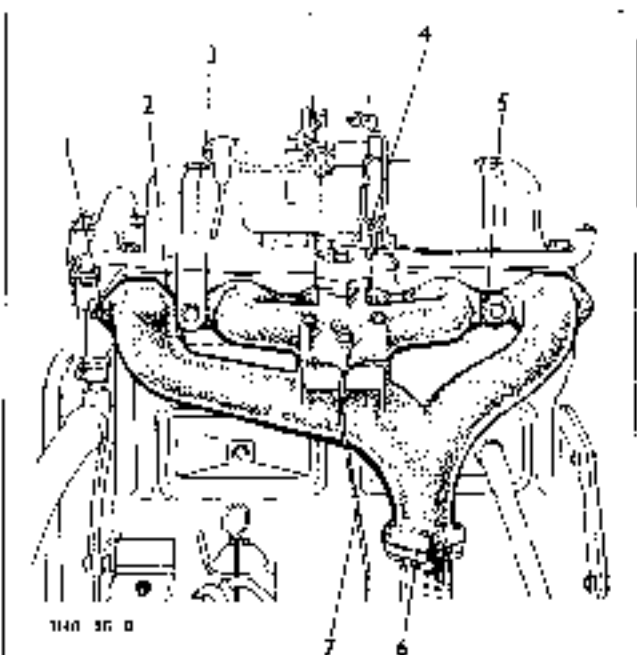

Fig. 2. The Manifolds.

1. Manifold stud and nut
2. Manifold joint washer
3. Carburettor feed pipe
4. Throttle stop screw
5. Manifold clamp and bolt
6. Exhaust pipe joint
7. Manifold down pipe

### Manifolds (Sports)

There are two separate cast induction manifolds fitted to the Sports engine. Each manifold feeds two inlet ports from one carburettor. Flanged at each end the manifolds are bolted to the carburettor flanges and the cylinder head.

Joining these two manifolds is a balance pipe. The function of this balance pipe is to even the gas pressure fed to the engine.

The exhaust manifold is identical to the Saloon version, with the exception that there is no "hot spot" incorporated and that it is not connected directly to either of the inlet manifolds.

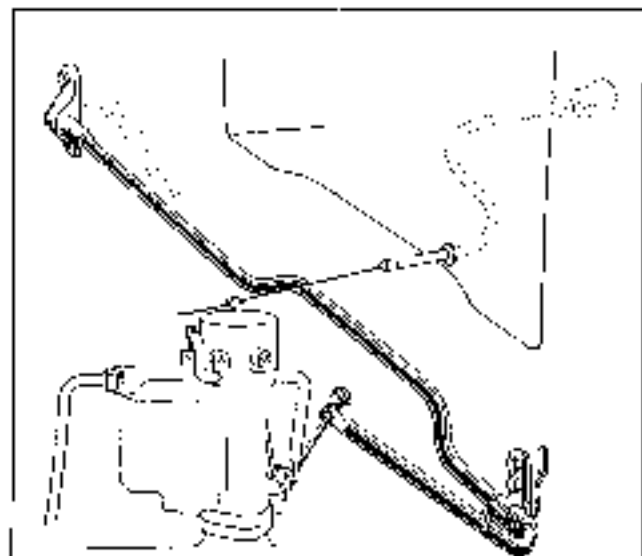

Fig. 3. The throttle layout and strangle control.  
The clip beneath the lever must grip the outer casing of the choke control.

### Throttle Linkage (Saloon)

The accelerator shaft is carried in a bearing and support which are attached to the toe board of the body.

Its free end is connected to a link attached to the carburettor, this link has spring loaded ball joints at each end and these, together with the other moving parts of the linkage, should be occasionally lubricated with oil. See Fig. 3.

The strangle control is a "Bowden" type cable with a friction control knob on the instrument panel.

It is important that the clip, situated inside the car, should be tightened sufficiently to grip the outer casing of the cable. This will ensure that the strangle cable will operate correctly.

The carburettor casting incorporates a bracket bearing to hold a cranked rod which is connected at one end to the throttle control lever and at the other end directly to the accelerator pump.

### Throttle Linkage (Sports)

The cranked accelerator pedal arm of the Sports car is identical to that of the Saloon.

From the pedal arm a ball joint connecting link joins up with the throttle connecting arm 6 of Fig. 4.

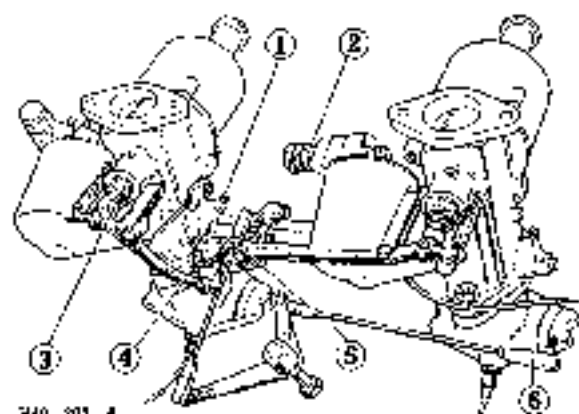

340, 307, A.

Fig. 4. The Sports throttle linkage and jet levers.

1. Throttle adjuster.
2. Fuel feed connection.
3. Main jet adjusting nut.
4. Choke cable securing point.
5. Jet lever connecting rod.
6. Throttle connecting arm.

The movement is continued through a bell crank lever which, in turn, is fixed to the common main throttle rod by a further ball joint connector.

In Fig. 4, it can be clearly seen that the two S.U. carburetters have their jet levers synchronised by a short cranked rod. At the rear carburetter this rod is linked to the jet lever by a split pin, whilst at the foremost carburetter the rod is secured to the jet lever by two nuts.

### Exhaust Pipe (Saloon)

Fitted in three separate parts, the exhaust pipe assembly is held in position by two brackets to the chassis frame and by the manifold studs.

To remove the exhaust pipe from the chassis proceed as follows:

Disconnect the bracket from the underside of the rear cross member of the chassis by releasing the single self-locking nut from its stud. Do not lose the rubber mounting bush.

Next slacken the two nuts and bolts of the pipe clip immediately before the silencer. Pull the tail pipe and silencer to the rear in order to clear the down pipe. Lower the silencer end of the tail pipe and extract it from the chassis frame by taking it forward.

Finally the down pipe. Disconnect the pipe from the three manifold studs, then lower the pipe and take it forward from the chassis.

*Note:* The exhaust pipe on the commercials is removed in the same manner as for the saloon with the exception that the tail pipe is fastened to the right-hand side of the chassis rear cross member.

### Exhaust Pipe (Sports)

Fitted in two parts, the exhaust pipe assembly is held in position by two brackets to the chassis frame and by the manifold studs.

To remove the exhaust pipe from the chassis proceed as follows:—

Disconnect the bracket from the underside of the rear cross member of the chassis by releasing the setpin and self locking nut. Do not lose the two rubber mounting pads.

Next slacken the nut and bolt of the pipe clip immediately before the silencer. The silencer can now be removed by pulling rearwards. Undo the two setpins from the bracket, situated at the rear of the boxed part of the chassis, which holds the rear portion of the down pipe in position. Remove the three nuts and flat washers which hold the down pipe to the manifold. Lower the pipe and remove from beneath the car.

*Note:* Down pipe and silencer can be removed as one if so desired.

## G.S.4. CARBURETTER

### GENERAL DATA

Make	Zenith	Compensating jet	65
Type	30 V1G-8	Slow running jet	50
Choke tube	25	Needle and Seating	1.5
Main jet	90	Pump Jet	50

The carburetter is of the Zenith downdraught type which embodies an accelerating pump and economy device. A fully automatic strangler flap interconnected with the throttle is also incorporated for starting purposes.

The strangler promotes rapid warming up after the initial engine firing has been obtained.

### Working Description

Petrol enters the carburetter at the union and passes on to reach the needle seating. Unless the float is already lifted against the needle by petrol in the float chamber the petrol will continue its course past the needle into the float chamber. It continues to flow

until the various passages are filled and the petrol reaches a pre-determined level at which the float contacts the needle pushing it on to its seating and thus shutting off the flow of petrol and so preventing the carburettor from flooding.

Petrol will have entered the passage in the base of the bowl by passing through the outlet and the economy jet. It will then pass through the main jet into the main channel in the emulsion block. Here it will remain at the pre-determined height, which is just below the emulsion block outlet.

The petrol will also have passed through to the compensating jet from which the fuel flows along the passage above it and joins the petrol from the main jet in the common channel.

From the main channel in the emulsion block petrol will pass into the slow running jet drilling. Similarly the well of the capacity tube, which is integrally cast in the float chamber, will be filled to the petrol level by the fuel flowing from the emulsion block.

As long as there is a supply of petrol from the tank, or pump, the fuel will occupy the position described whilst the engine is stationary.

### Starting

In starting from cold, the strangler control should be pulled outwards to close the strangler flap of the carburettor air intake. A cam on the end of the strangler spindle will at the same time, via a connecting link, open the throttle slightly, thus ensuring sufficient volume and richness to give instant starting when the engine is turned over with the ignition switched on. A rich mixture is necessary purely to obtain initial firing. Weaker mixture

and greater volume is now necessary. The strangler flap is free to move on the spindle and is only held closed by the spring on the spindle. Immediately the engine fires its speed will increase, thus creating extra suction on the lower side of the strangler flap, sufficient to break down the tension of the spring holding the flap closed. This will cause the flap to open progressively and so admit air, thus giving the necessary weakening effect to the fuel and providing greater volume.

Once the initial firing has been obtained the automatic strangler provides a more normal mixture and causes the engine to run at a speed which prompts rapid warming up and efficient idling, thereby minimising cylinder wear.

If necessary the vehicle can be driven away immediately with the strangler still in action, but it is wise to return the strangler control to the inoperative position as soon as the engine temperature is sufficient to allow the main carburettor only to be used.

### Main Carburettor

When running on the main carburettor with the throttle closed down to the idling position, the mixture will be supplied from the slow running jet 18, Fig. 6.

With the strangler out of action and the throttle just slightly open, the depression will be concentrated on the outlet, which will in turn be directed on the slow running jet 18. Consequently petrol will be drawn from the well beneath the jet, measured on passing through, and will meet an entering at the base of the adjustment screw 17, Fig. 6. The amount of air mixing with the petrol from the slow running jet is controlled by this screw.

Caption for Fig. 5.

1. Strangler flap.	25. Throttle stop screw.	49. Needle and seating.
2. Choke tube.	25. Spring for throttle stop screw.	50. Needle and seating washer.
4. Air regulating screw.	27. Carburettor body.	51. Compression washer for auto ignition connection.
4. Air regulating screw spring.	28. Throttle.	52. Plug for compression washer.
5. Spring (automatic).	29. Emulsion block screws (sheet 11).	53. Carburettor bowl gasket.
6. Spring carrier.	30. Emulsion block screw (long).	54. Drive screws fixing gasket.
7. Split pin.	31. Washers for emulsion block lower screws.	55. Plug for petrol correction.
8. Choke tube fixing screw.	32. Emulsion block.	56. Compression washer for petrol correction.
9. Bearing plate screw.	33. Gasket for emulsion block.	57. Carburettor bowl screw, plain type.
10. Bearing plate for pump control.	34. Carburettor bowl.	58. Carburettor bowl screws, jet key type.
11. Pump control lever.	35. Main jet washer.	59. Pump rod.
12. Pump control link.	36. Compensating washer.	60. Pump rod spring.
13. Washers for link.	37. Non-action valve.	61. Washer for pump spring.
14. Split pins for link.	38. Compensating jet.	62. Washer for pump rod piston.
15. Floating lever and interconnecting line assembly.	39. Main jet.	63. Split pin for piston.
16. Washer for throttle spindle.	40. Pump jet.	64. Strangler flap fixing screws.
17. Throttle lever.	41. Slow running jet.	65. Saws for interconnecting swivel.
18. Shakeproof washer.	42. Bail valve.	66. Strangler spindle.
19. Nut for throttle spindle.	43. Spring for pump piston.	67. Bearing for strangler spindle.
20. Gaskets for economy diaphragm.	44. Pump piston.	68. Screw for control wire swivel.
21. Economy diaphragm.	45. Stop screw for piston.	69. Strangler lever.
22. Diaphragm spring.	46. Float.	70. Strangler spring.
23. Economy valve cover.	47. Throttle fixing screws.	
24. Fixing screws for cover.	48. Throttle spindle.	



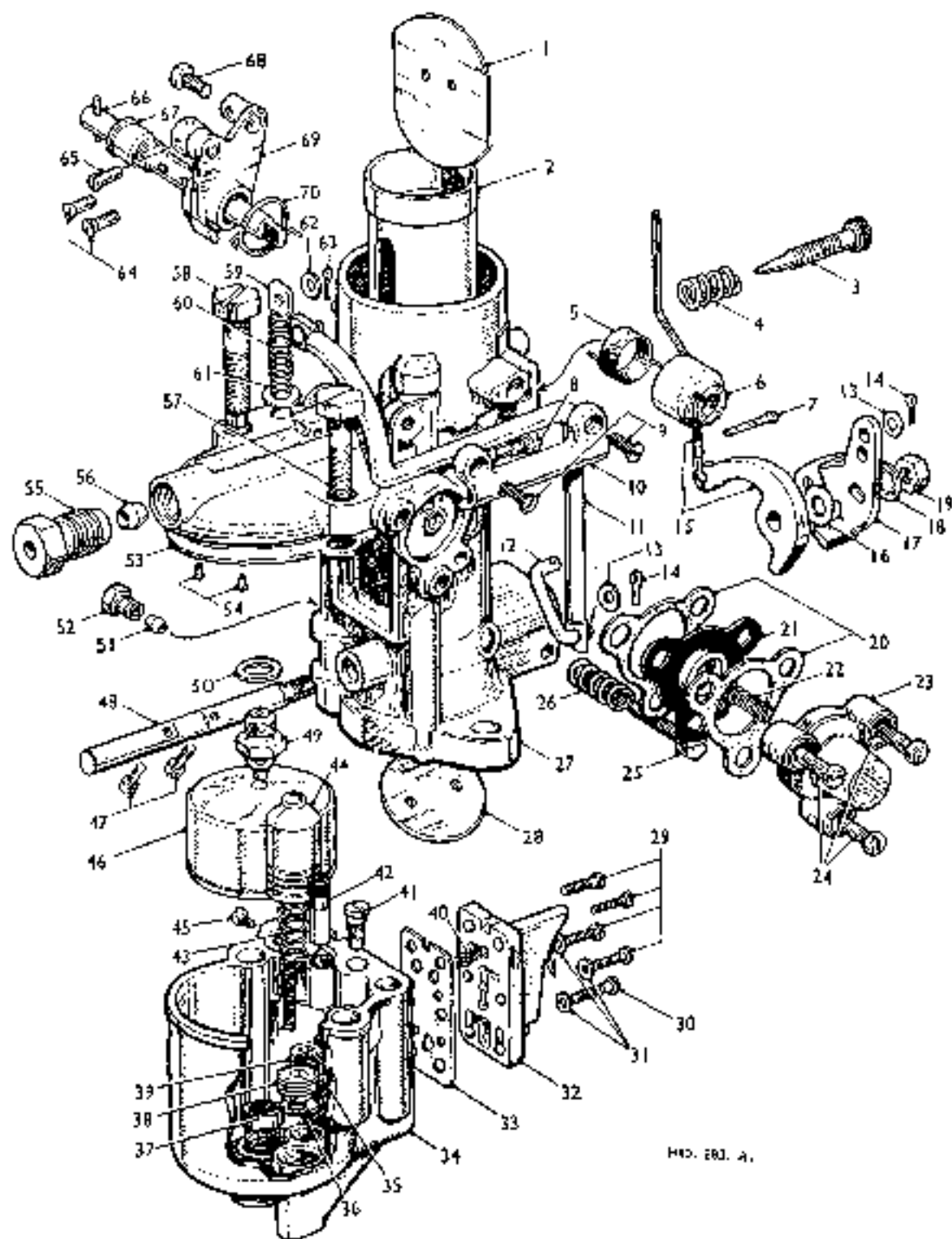

FIG. 283. A.

Fig. 5. An exploded view of the Zenith carburettor 30V10-B.

In the interests of fuel economy, during the summer months the owner can alter the carburettor setting by shortening the pump stroke, i.e., moving the pump control link rod 12 to the lower hole in the throttle lever 17. However, if cold weather is encountered, the owner must be prepared for "flat-spots" on acceleration.

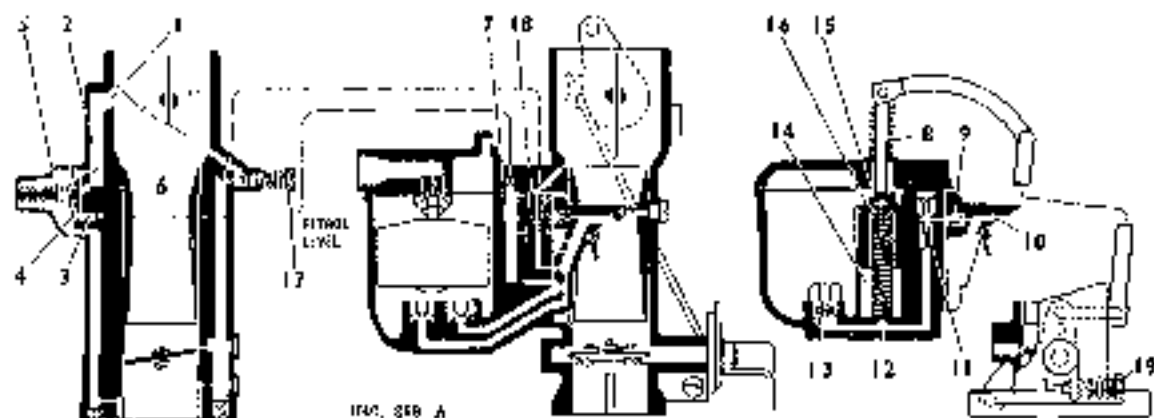

Fig. 6. Diagrammatic section of carburetor.

At the throttle edge there is a further outlet which breaks into the slow running passage. Upon the throttle being opened from the idling position it will give an additional mixture to ensure progressive get-away from slow-running; this explains the title "progression jet".

Further opening of the throttle will cause the depression to be concentrated on the nozzle of the emulsion block which projects into the narrowest part of the choke tube. This results in petrol being drawn from the common channel, the passage of the slow running jet and main jet outlet, so that the source of petrol supply is eventually through the main jet and compensating jets. It will be observed that petrol in the well of the capacity tube 7 (Fig. 6) has been consumed and, as the top of the well is open to the atmosphere, petrol rising from the main and compensating jet is now under atmospheric pressure. As a result petrol drawn from the jets will be broken up in the main channel by air from the capacity tube. This mixture will then be drawn from the emulsion block nozzle into the choke tube.

It is essential that this mixture should be distributed completely across the choke tube in all directions. To obtain this even distribution, a small circular bar has been integrally cast across the choke tube at right angles to the emulsion block nozzle, with a further short circular bar at right angles to it.

The inrush of air from the intake of the carburetor will strike these two bars and so create a vacuum on the sides facing the engine. The petrol-air mixture leaving the emulsion block will run along the bars, filling up the vacuum and then proceed past the throttle valve into the induction pipe.

It will be realised that as soon as the petrol in the float chamber falls below the predetermined level, the float will fall so allowing the needle valve to open, thus

a controlled flow of petrol to the float chamber is assured.

There is an outlet providing for the vacuum timing control union.

#### Economy Device

When the manifold depression is high a leaner mixture can be employed. This is the principle governing this economy device.

Following normal V type carburation practice, the air bleed up to the jets is by way of the capacity well 7 (Fig. 6). The air bleeding originates at the drilling 1 inside the air intake.

When the depression in the manifold is low the diaphragm 4 prevents air being supplied to the capacity well 7 and consequently to the jets, through the main drilling 6. The only supply is by means of the restricted passage 2.

The condition will prevail until the depression in the manifold, and therefore at the drilling on the engine side of the throttle, is connected to the diaphragm chamber by a passage, is great enough to overcome the tension in the spring 5 and cause the diaphragm valve 4 to lift off its seating. Immediately it does so the drilling 6 is uncovered. This results immediately in greater air release of the depression acting upon the jets. The effect will be to reduce the output of the jets and so provide the weaker mixture that can be employed during the period when the manifold depression is sufficiently high.

The automatic control over the mixture valve, which is dependent upon engine demands, at once indicates the economy that must result.

#### Accelerating Pump

The object of this pump is to overcome any tendency for a lag in acceleration which may be apparent when a carburetor is adjusted to give low petrol consumption

at normal driving speeds. In order to obtain economical running at such speeds and yet ensure faultless acceleration, a controlled and measured supply of mixture is necessary when the throttle is opened suddenly. This is provided by the accelerator pump.

Operation of the pump coincides with the depression of the accelerator pedal. By means of an interconnection with the throttle lever the pump rod 8 (Fig. 6) forces down the piston 15 against the action of the spring 16 as the throttle is opened. Consequently petrol in the pump well 14 is forced out through the drilling 12 in the base of the well. See also Fig. 7.

Fuel cannot return to the float chamber because of the non-return type inlet valve 13. The only outlet is through the ball valve 11 in the pump jet 9 and is then ejected from the emulsion block beak, in the form of a fine spray, into the barrel of the carburettor. From here it is carried by the rushing air stream past the throttle into the manifold. In consequence depression of the accelerator pedal produces instantaneous engine response.

#### Adjustment

The carburettor settings have been so set as most suitable for the engine after extensive experimental work. Consequently very little adjustment to the carburettor should be needed. Adjustments should only be made

when absolutely necessary. The setting of the slow running mixture and the idling speed of the engine are the only likely alterations needed, apart from an occasional cleaning of its jets and float chamber bowl.

When trouble with the running of the engine is experienced do not assume that it is always due to the carburettor. Check all other possible causes of trouble such as sparking plugs, timing of ignition and condition of valves, before making alterations to the carburettor.

#### Dismantling of the Carburettor

Before dismantling, ensure that all parts, the hoses and the bench are clean. The hand should be placed beneath the bowl during this operation so that on removal of the retaining bolts it will drop into the hand. (Economy note: petrol in the bowl can be emptied back into the tank.)

The jets should be removed occasionally and thoroughly cleaned. One of the retaining bolts is squared at the end to fit into the jet covers and jets. This facilitates their removal when used in conjunction with a suitable spanner.

#### Cleaning the Jets

When cleaning the jets do not pass anything through them—such as wire that is likely to damage the carefully calibrated orifices. The most satisfactory and efficient method is to blow through them with air, free from moisture, and wash with clear petrol. This should remove any obstruction and will leave the jets undamaged. The sizes of all jets are clearly numbered—the larger the jet the greater the number. The slow running jet is provided with a screw-driver slot to enable it to be removed. This applies also to the screw in the capacity tube.

#### Float

If there have been signs of flooding the float may be suspected of being punctured. To remove the float release the large-headed screw at the side of the float chamber and immerse in boiling water, when rising bubbles will indicate the exact location of the puncture. When the petrol inside has thus been evaporated seal the puncture with a spot of solder. This is essentially a temporary expedient, as the extra weight of solder may cause a difference in petrol level in the bowl. Fit a new float at the earliest opportunity.

#### Emulsion Block

The emulsion block is held to the side of the bowl by five screws. Particular care should be taken to avoid damage to the washer beneath the block in the event of removal. When replacing insert the bottom screw first and then tighten all five evenly.

The progression jet is removed by a screwdriver,

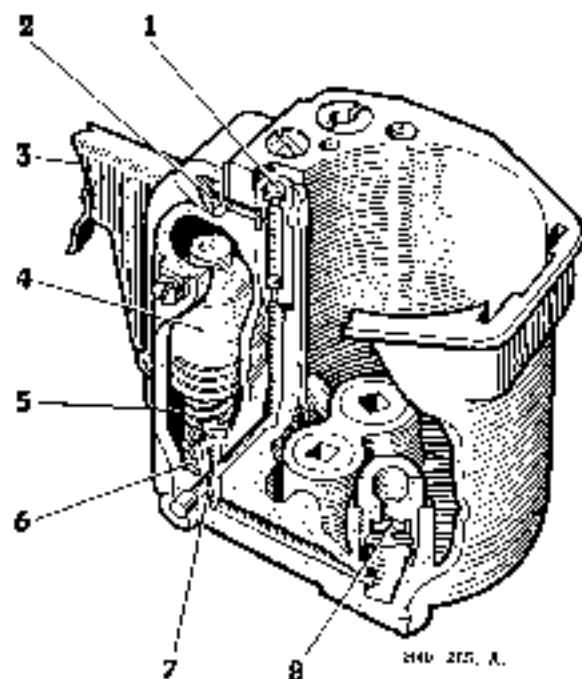

Fig. 7. The accelerating pump.

- |                         |                           |
|-------------------------|---------------------------|
| 1. Ball valve.          | 5. Pump well.             |
| 2. Pump jet.            | 6. Pump spring.           |
| 3. Emulsion block beak. | 7. Drilling to pump well. |
| 4. Pump piston.         | 8. Non-return valve.      |

the jet cover having been first removed; make sure that the latter is replaced after inspection.

#### Slow Running Adjustment

The stop screw 19 (Fig. 6) determines the speed of slow running. To increase the slow running speed, the stop screw must be turned in a clockwise direction. If turned anti-clockwise, a slower "tick-over" will be obtained.

The richness of the slow-running mixture is controlled by the air-regulating screw 17. Should the engine refuse to "tick" over for any length of time or stall on deceleration, the slow running jet 18 may be choked and should be cleaned. After examination re-set the slow running by means of the throttle stop screw and the air regulating screw. If the engine is inclined to hunt when running slowly the mixture is too rich and must be weakened by turning the air regulating screw in an anti-clockwise direction. The best position for this screw, from the point of view of pick up, is within three turns of the full home position. Check by speeding up the engine and releasing the accelerator pedal quickly. If the engine stalls, the slow running adjustment is not correct and the idling speed should be slightly increased to a point where the sudden release of the throttle after accelerating allows the engine to settle to an even "tick over". Do not expect a new engine which is tight in its bearings to idle perfectly.

It must be borne in mind that factors other than the carburettor such as non air-tight joints, worn valve guides, valves not seating, ignition too far advanced and incorrect setting of sparking plug gaps can have considerable influence on "slow running" when the engine is out of gear with the car stationary. Such details should always be given consideration when the slow running is irregular. The carburettor alone should not be suspected.

#### General

Swill out the bowl of the carburettor occasionally with clean petrol to remove any sediment that may be present.

Under normal conditions no other attentions or adjustments should be necessary. Once correctly set, many thousands of miles of satisfactory running should be obtained.

Should the car be used in very hot climates or at very high altitudes, a slightly weaker setting may be used, or, alternatively, if used in very cold climates, larger jets may be necessary.

Advice on this question will readily be given on application to Service Department, or the Zenith Carburettor Co. Ltd., Honeyput Lane, Starnore, Middlesex.

## SPORTS S.U. CARBURETTERS

#### General Description

Two S.U. carburetters, inclined at an angle of 20 degrees to the horizontal, are fitted to the Sports. There is only one jet per carburettor and the fuel flow through this jet is regulated by a needle (model EK). The piston employed to move the jet needle is controlled by a hydraulic damper.

#### Working Description

Fuel from the pump enters the float chamber cap at the banjo type union (A), Fig. 6.

Passing through the strainer (B) the fuel flows to the valve opening (C). The valve needle is forced down allowing the fuel to fill the float chamber. The float rises on its guide pin and shuts off the fuel supply by pushing the valve needle back on to its seating.

The fuel now continues to flow from the float chamber to the union (E), then passes on to the main jet (G).

Controlling the fuel supply through this jet is a

tapered needle (H), see also Fig. 9, which is secured to the piston (J). The head of the piston is flanged and grooved to form a suction disc (I).

Suction from the inlet manifold, controlled by the butterfly throttle, causes the piston to travel upwards or downwards, thus the needle at its tapered end controls the supply of fuel drawn through the jet (G).

A hydraulic damper (K) is fitted to the piston chamber. This damper has the effect of restraining the upward movement of the piston on acceleration and so giving a slightly enriched mixture.

Main jet adjustment is determined by the nut (M); see notes on adjustment.

For choking when first starting up, the main jet is moved downwards by the lever (L) which in its turn is cable operated by the knob on the fascia. With the throttle opened slightly a richer mixture is obtained. Once the choke control is released and the throttle operated for running, the jet returns to its seat and the needle and piston resume control of the fuel supply.

## CARBURETTOR MAINTENANCE

## Float Chamber Assemblies

The float chambers should be cleaned out regularly (every 5,000 miles) not forgetting the chimney filters in the chamber caps.

First undo the petrol-pipe bayonet-bolts, when the chimney filters can be removed. Next slacken the float chamber cap nuts and uncouple the steel struts which are connected to the induction pipes. Finally unscrew the float chamber securing bolts and then the chambers themselves can be removed and cleaned out.

Be careful not to lose the float levers, pins or needles. Flooding of a float chamber can be detected by the fuel flowing over the float chamber and dripping from the air inlet. Generally this can be attributed to a particle of grit between the float-chamber needle and its guide.

Should the engine stop, apparently through lack of fuel when there is plenty in the tank, the probable cause is a sticking float needle. Remove the float chamber lid, clean the needle and its seating, and then reassemble. At the same time it would be advisable to clean out the

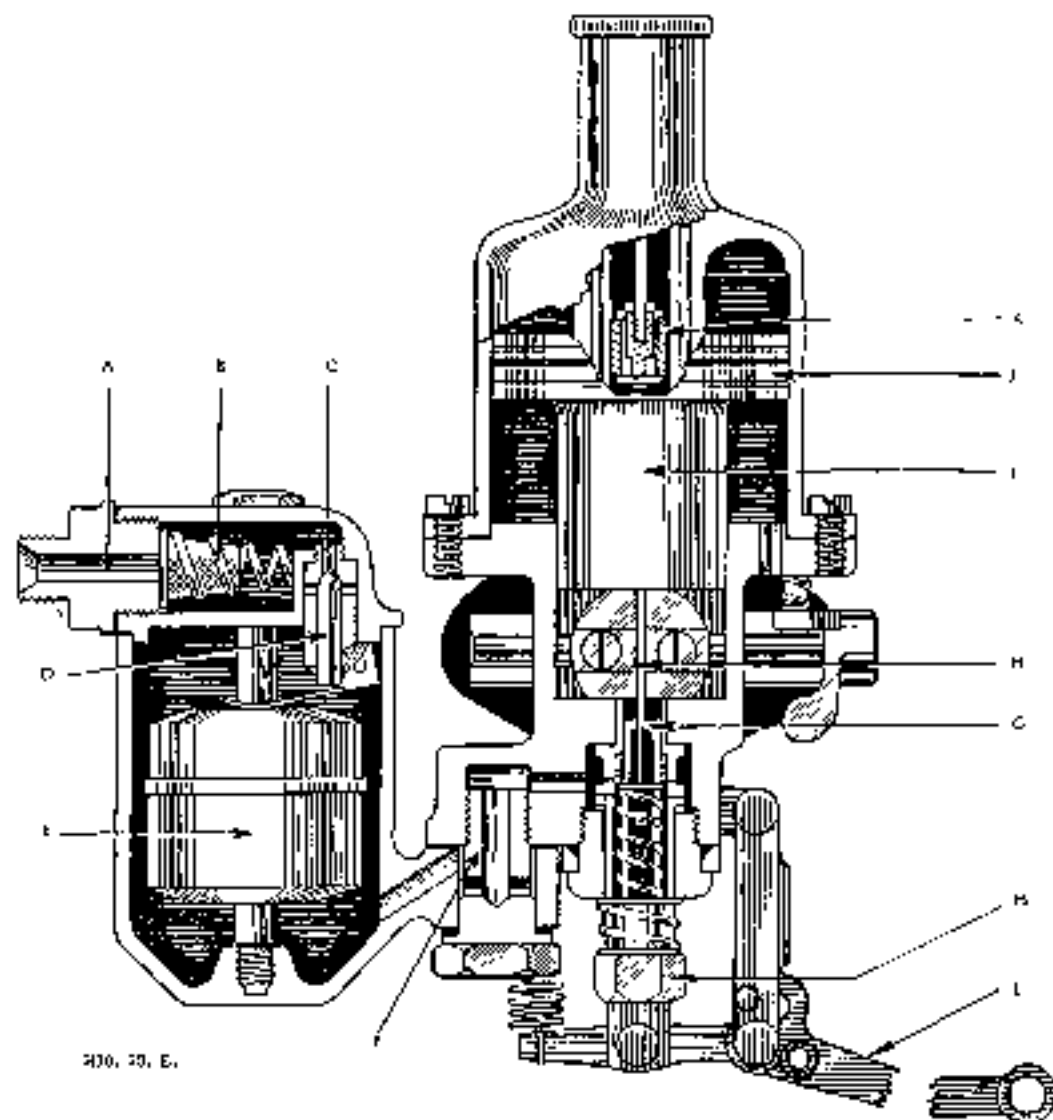

410, 25, E.

Fig. 8. Sectional view of S.U. carburettor.

- |                         |                                       |                            |
|-------------------------|---------------------------------------|----------------------------|
| A. Bayonet union.       | E. Float.                             | J. Suction disc            |
| B. Steiner and springs. | F. Float chamber securing union bolt. | K. Hydraulic damper.       |
| C. Valve opening.       | G. Main jet.                          | L. Choke lever.            |
| D. Needle valve.        | H. Needle.                            | M. Main jet adjusting nut. |
|                         | I. Piston.                            |                            |

entire fuel feed system, as this complaint is caused by foreign matter in the petrol. Unless this is done the trouble is likely to recur.

#### Hydraulic Piston Dumper

This is a device located in the hollow piston rod and attached to the oil cap nut. It consists of a plunger with a one-way valve and its function is to give a slightly enriched mixture by preventing the piston from rising too quickly on acceleration.

The only attention necessary is to keep it supplied with thin oil. See "Regular Attention."

#### Piston

The suction piston comprises the piston, forming the choke, the needle and the suction disc. Into this assembly is inserted the hardened and ground piston rod which works in the bearing of the suction chamber. The piston rod running in the bearing is the only part which is in actual contact with any other part—the suction piston and needle having clearance fit and consequently should not cause sticking. If this does occur the whole assembly should be carefully cleaned and the piston rod only should be lubricated with a spot of thin oil.

A sticking piston can be ascertained in a few seconds by inserting a finger in the air intake and lifting the piston. The piston should come up quite freely and fall right on to its seat when released.

#### Centring the Jet

Should it be essential to remove the jet, this can be done by unscrewing the jet holding screw, see Fig. 10. It must be understood that the needle is very nearly as large as the jet, and jet must not touch it.

When reassembling it is necessary to carefully centre the jet to the needle by adopting the following procedure:—

First remove the pin at the base of the jet, attaching the jet head to the jet operating lever. Withdraw the jet completely and remove the adjusting nut and adjust

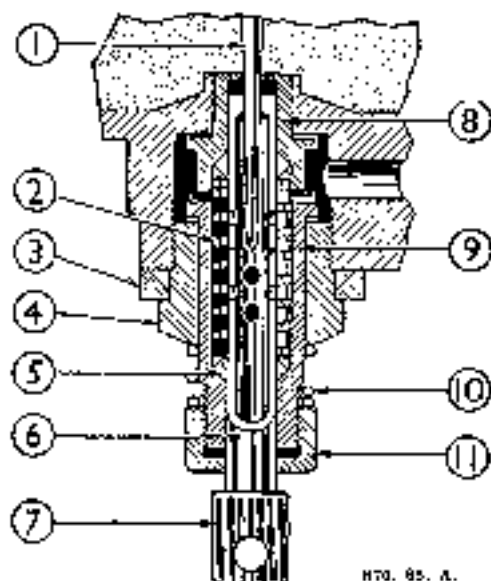

Fig. 10. Sectional view of the jet.

- |                       |                                |
|-----------------------|--------------------------------|
| 1. Flycast needle.    | 7. Jet head.                   |
| 2. Spring.            | 8. Top half of jet bearing.    |
| 3. Brass washer.      | 9. Bottom half of jet bearing. |
| 4. Jet holding screw. | 10. Adjusting nut spring.      |
| 5. Jet gland washer.  | 11. Adjusting nut.             |
| 6. Jet.               |                                |

ing nut spring. Replace the adjusting nut, without its spring, and screw up to its highest position.

When this has been done, feel if the piston is perfectly free by lifting it up with the finger. If not, slacken the jet screw and manipulate the lower part of the assembly, including the projecting part of the bottom half jet bearing, adjusting nut and jet head. Make sure that this assembly is not loose.

The piston should now rise and fall quite freely as the needle is now able to move the jet into the required central position.

Now the jet screw should be tightened and a check made to determine that the piston is quite free. If it is found not to be so, the jet screw should be slackened and the operation repeated.

When complete freedom of the piston is achieved the jet adjusting nut should be removed, together with the jet, and the spring replaced. The adjusting nut should then be screwed back to its original position.

#### Adjusting the Carburettors

To make a thorough job of adjusting twin S.U. carburettors it is advisable to check, first of all, tappet clearances, plug gaps and distributor gap to ensure that these agree with the information given in other relative sections within this manual.

The carburetors should then be inspected to see that the pistons are perfectly free and that the jets are correctly centred.

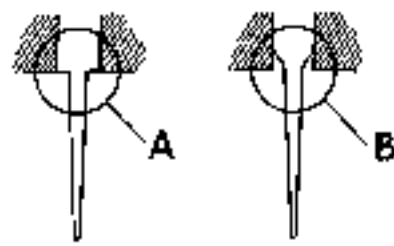

Fig. 9. Showing the two forms of tapered needle.  
A. Square shoulder. B. Tapered shoulder.

Now slacken the clamping bolts on the universally jointed connections between the throttle spindles. Disconnect the mixture control linkage by removing one of the link swivel pins. While the suction chambers are off make sure that the needles are located in the same position in the pistons and that the jets are the same distance below the bridges of the carburettors when they are pushed hard against their adjusting nuts.

Unscrew the throttle adjusting screws and screw these back until they will just hold a piece of thin paper inserted between the adjusting screw and the stop lug, then screw in one complete turn.

The engine may now be started. When it is thoroughly warmed up the speed may be adjusted by turning the throttle adjusting screws equal amounts in either direction, depending on whether a higher or lower speed is required.

To check for exact synchronisation of the throttle openings it is best to listen to the intake. This is easily done by inserting one end of a length of rubber tubing in the ear and holding the other end near the intake of each of the carburettors in turn. If the hiss or noise of them is louder than on the other, unscrew its throttle adjusting screw until the hiss is equal. When it is obvious that this is satisfactory the mixture should be adjusted by screwing the jet adjusting nuts up or down equal

amounts, pushing the jets hard up against them, until satisfactory running is obtained. As these are adjusted the engine will probably run faster and it may therefore be necessary to unscrew the throttle adjusting screws a little, by equal amounts, in order to reduce speed.

When the mixture is correct on both carburettors lifting the piston of one of them with a penknife blade should make the engine beat become irregular from excessive weakness. If lifting the piston on one carburettor stops the engine and lifting that of the other does not, this indicates that the mixture on the first carburettor is weaker than on the second and therefore the first one should be enriched by unscrewing the jet adjusting nut.

Once the mixture is correct from both carburettors the exhaust beat should be regular and even. If it is irregular, with a splashy type of misfire and colourless vapour, the mixture is too weak. A regular or rhythmical type of misfire in the exhaust beat, together with a blackish vapour, denotes a mixture that is too rich.

Before re-connecting the mixture control linkage, make sure that the jets are hard up against the adjusting nuts and, if necessary, adjust the length of the linkage so that the swivel pins may be inserted while the jets are in this position. The throttle spindle connection clamping bolts may now be tightened.

## AIR CLEANER AND SILENCER

### Air Cleaner (Saloon)

One of two types of air cleaner may be fitted to the Saloon. The type illustrated in Fig. 12 is fitted to cars for the export market.

The normal air cleaner, fitted to cars for the home market, is of the oil-wetted type as shown in Fig. 11, and apart from regular cleaning, requires little or no attention.

To remove either type of air cleaner from its position slacken the clip that secures it to the carburettor. Disconnect the breather pipe and the air cleaner support bracket from the valve rocker cover. Lift off the air cleaner.



Fig. 11. Oil-wetted type air cleaner.

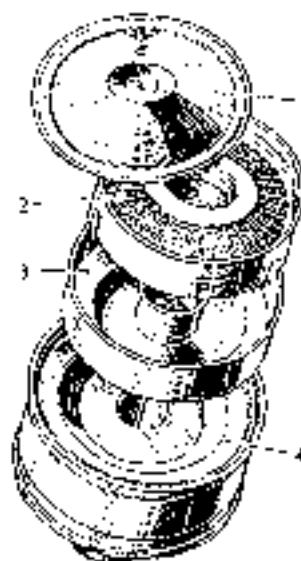

FIG. 12.

Fig. 12. An exploded view of the mud bath type air cleaner.

1. Sealing disc. 2. Gauge filler. 3. Oil compartment. 4. Main unit housing.

Approximately every 5,000 miles the oil bath type of cleaner should be dismantled, cleaned and refilled with new oil to the level indicated by the arrow. In countries where the atmosphere is heavily dust laden, cleaning should be carried out at more frequent intervals.

To dismantle the oil bath simply release the wing nut on top of the cleaner. Lift out the wire wool strainer from the oil bath and rinse in petrol. Allow this strainer to become thoroughly dry before reassembling the cleaner.

#### Air Cleaner (Sports)

A Voxes dry element type air cleaner and silencer is fitted to each Carburettor.

These air cleaners should be dismantled every 2,000 miles and the elements tapped gently or brushed lightly on the outside. If compressed air is available the element can be effectively cleaned by directing a jet of air on to the inside surface, thus blowing the dust particles out of, and not into, the filtering material. An element that has become contaminated with oil or grease should be thoroughly washed in petrol and allowed to dry before being replaced. Note: new elements should be fitted every 10,000 miles or more frequently in regions where an excessively dust laden atmosphere prevails.

Access to the air cleaner elements is gained by first removing the set screw and pulling off the top cap. The elements can now be extracted from the perforated cylinders for inspection and cleaning.

To remove the front air cleaner complete, disconnect the breather pipe by slackening its clip at the air cleaner and, then unfasten the supporting stay by undoing the setpin, washer and nut at the silencer base. Remove

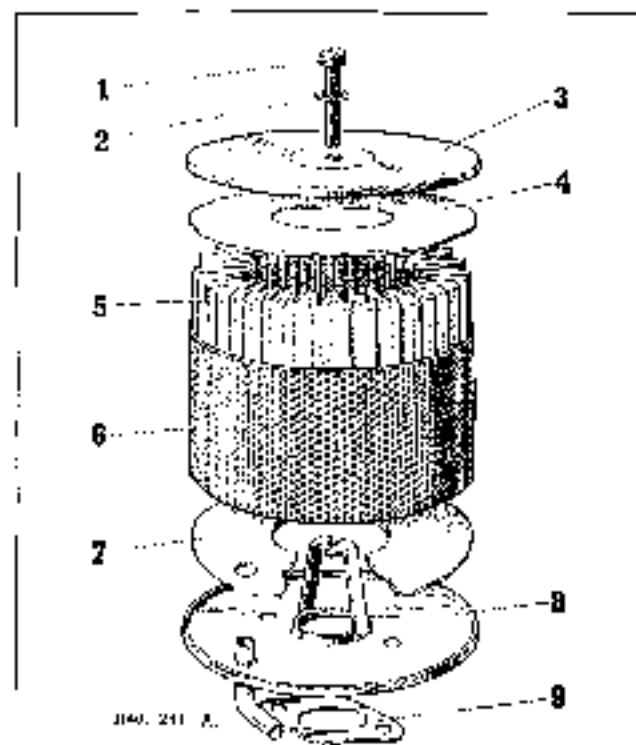

Fig. 13. The Sports air cleaner exploded.

1. Set screw 2. Washer 3. Top cap 4. Felt pad.  
5. Element 6. Perforated cylinder 7. Felt pad  
8. Bottom cap 9. Joint.

the two nuts and washers that hold the air cleaner to the carburettor flange when it will be free to be lifted clear.

Both front and rear silencers are removed in an identical manner save that the rear one has no breather pipe connection.

## FUEL PUMP

#### Type and Description

The A.C.-Sphinx Fuel Pump, Type "U", is operated mechanically from an eccentric on the engine camshaft. The normal working pressure is  $1\frac{1}{2}$  to  $2\frac{1}{2}$  lbs. per square inch. A clear impression of the working parts is given in Fig. 14.

#### Method of Operation

As the engine camshaft "8" revolves the eccentric "9" lifts the pump rocker arm "10" pivoted at "11" which moves the pull rod "14" together with the diaphragm "5" downward against pressure of spring "6", thus creating a vacuum in the pump chamber "16".

Petrol is drawn from the tank and enters at "20" into the sediment chamber "17" through the filter gauze

"1", suction valve "19" into the pump chamber "16". On the return stroke the spring "6" pushes the diaphragm "5" upwards, forcing petrol from the chamber "16" through the delivery valve "4" and opening "3" to the carburettor.

When the carburettor bowl is full the float will shut the needle valve, thus preventing any flow of petrol from the pump chamber "16". This will hold the diaphragm "5" downward against the spring "6" and it will remain in this position until the carburettor requires further petrol and the needle valve opens. The rocker arm "10" operates the connecting link by making contact at "12" and this construction allows idling movement of the rocker arm when there is no movement of the fuel pump diaphragm.



Spring "7" keeps the rocker arm "10" in constant contact with eccentric "9" to eliminate noise. The hand priming lever is indicated at "15" and the sediment drain plug at "18".

#### Cleaning the Filter

The filter (see Fig. 16) should be examined every 1,000 miles and cleaned if necessary. Under extreme conditions of dust-laden atmosphere this mileage interval should be reduced as conditions dictate.

Access to the filter is gained by removing the dome cover, after unscrewing the retaining screw, when the filter gauze itself may be lifted off its seating. Remove the drain plug and clean out the sediment chamber. Clean the filter gauze in air jet with petrol.

The cork washer under the filter cover should be renewed if broken or if it has hardened.

When refitting the cover make certain that the fibre washer is replaced under the head of the screw. Tighten the filter cover retaining screw just sufficiently to make a petrol-tight joint. Over-tightening will either destroy the cork washer, crack the cover, or fracture the main casting.

Check the pump to crankcase mounting bolts for tightness, also check the petrol pipe unions.

#### Testing while on the Engine

With the engine stopped and switched off, the pipe to the carburettor should be disconnected at the carburettor end, leaving a free outlet from the pump. The engine can then be turned over by hand, when there should be a well defined spur of petrol at every working

stroke of the pump, namely, once every two revolutions of the engine.

#### Removing from the Engine

First the pipe unions should be disconnected; the two nuts fixing the fuel pump to the engine crankcase should then be unscrewed, after which the fuel pump will come away readily.

#### Dismantling the Fuel Pump

Before commencing to dismantle clean the exterior of the pump and make a file-mark across the two flanges for guidance to facilitate reassembly in the correct relative positions. After separating the two main castings dismantling of the remaining components associated with each, is quite straightforward. The diaphragm and pull rod assembly can be withdrawn by first of all turning it through 90° (see Fig. 17). No attempt should be made to separate the four diaphragm layers from their protector washers and pull rod, as this is, at all times, serviced as a complete assembly, being permanently riveted.

#### Inspecting of Parts

First all parts (see Fig. 15) must be thoroughly cleared to ascertain their condition. Wash all parts in the locality of the valves in a clean paraffin bath separate from that employed for the other and dirtier components.

Diaphragm and pull rod assemblies should normally be renewed, unless in entirely sound condition without signs of cracking or hardening.

Upper and lower castings should be examined for cracks or damage and if the diaphragm or engine

Fig. 14. Diagrammatic section of the fuel pump.

1. Gauze filter.
2. Cork sealing washer.
3. Delivery union.
4. Delivery valve.
5. Diaphragm.
6. Diaphragm spring.
7. Anti-rattle spring.
8. Camshaft.
9. Camshaft eccentric.
10. Rocker arm.
11. Rocker arm pivot.
12. Connecting link.
13. Priming lever cam.
14. Diaphragm pull rod.
15. Priming lever.
16. Pump chamber.
17. Sediment chamber.
18. Sediment drain plug.
19. Suction valve.
20. Inlet union.

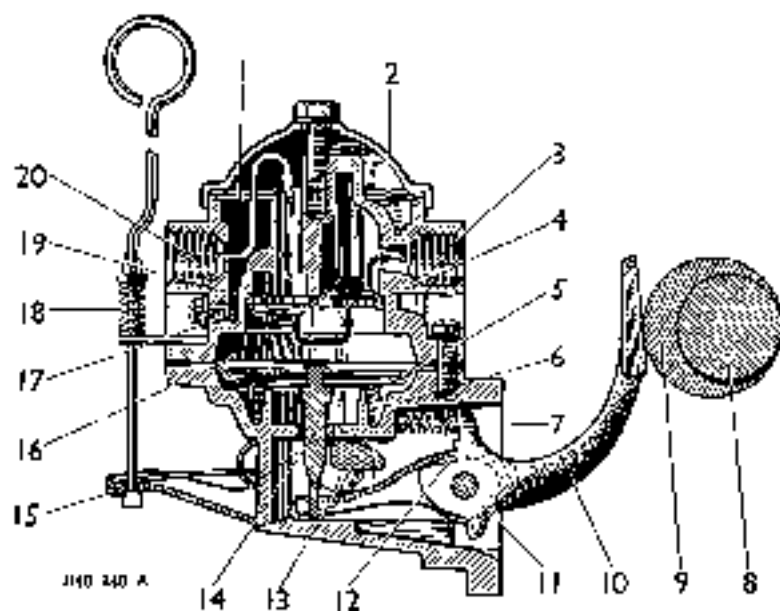

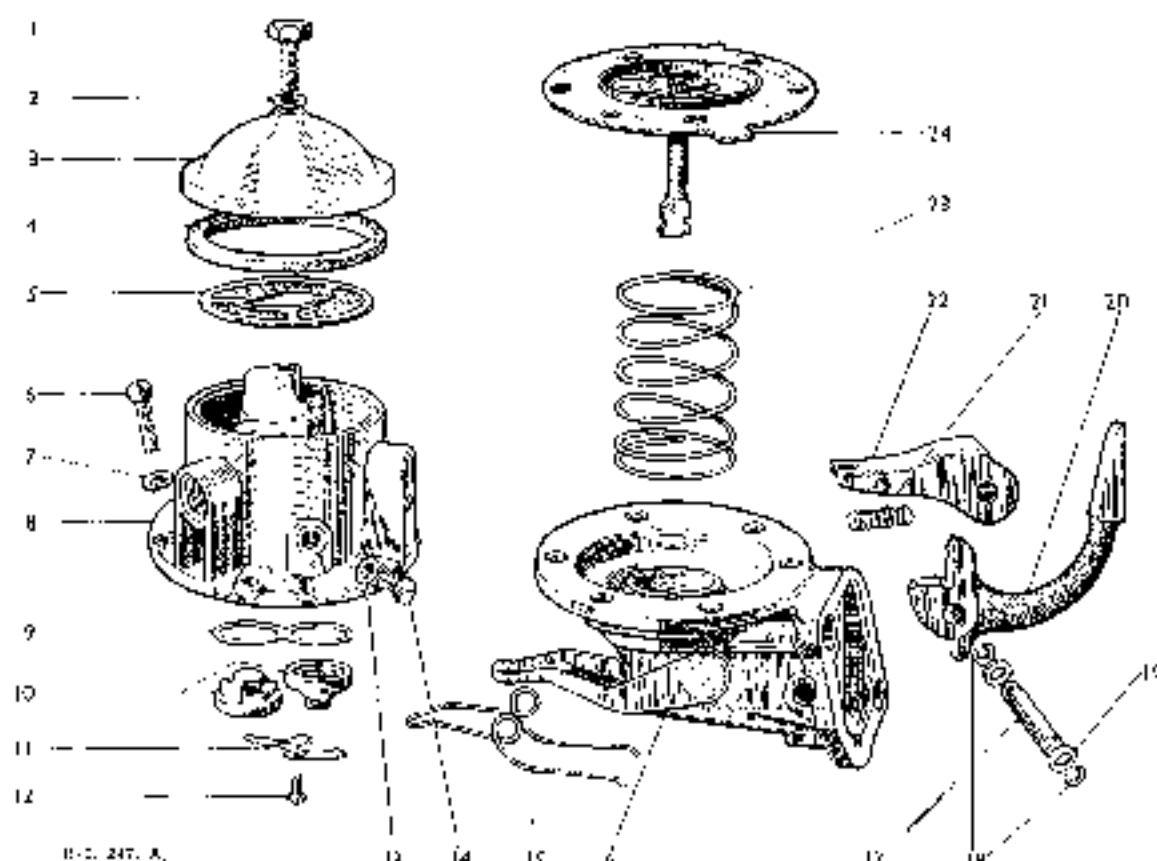

H.C. 247. A.

Fig. 15. Components of Fuel Pump.

- |                                 |                           |                           |
|---------------------------------|---------------------------|---------------------------|
| 1. Top cover screw.             | 9. Valve joint washer.    | 17. Rocker arm pin.       |
| 2. Cover screw washer.          | 10. Valves.               | 18. Rocker arm pin clips. |
| 3. Pump top cover.              | 11. Valve securing plate. | 19. Rocker pin washers.   |
| 4. Cork sealing washer.         | 12. Valve plate screw.    | 20. Rocker arm.           |
| 5. Filter gauze.                | 13. Drain plug washer.    | 21. Anti-rattle spring.   |
| 6. Upper chamber securing nuts. | 14. Drain plug.           | 22. Rocker link.          |
| 7. Washer for securing screw.   | 15. Priming lever spring. | 23. Diaphragm spring.     |
| 8. Upper chamber.               | 16. Lower casting.        | 24. Diaphragm.            |

mounting flanges are distorted these should be lapped to restore their flatness. Where the hand priming lever incorporated in the lower casting is broken the parts should be renewed, the outer end of the spindle being rickled over by hand tools after correctly locating the various components.

All badly worn parts should be renewed and very little wear should be tolerated on the rocker arm pins (17), the holes and engagement slots in the links (22), link in the rocker arm (20). On the working surface of the rocker arm which engages with the camshaft eccentric slight wear is permissible, but not exceeding .010 in. depth.

Fuel pump valves (10) should be renewed if at all worn. Diaphragm springs (23) seldom call for replacement but where necessary, ensure that the replacement spring has the same identification colour and consequently the same strength as the original. Rocker arm

springs (21) are occasionally found to be broken after service. All joint washers should be renewed.

#### Reassembling the Fuel Pump

The following procedure should be adopted dealing with the upper portion of the pump first.

Place the valve joint washer (5) in the pump upper casting.

Place the valves (10) in position.

Valves should be swilled in clean paraffin before reassembly. Apart from the cleaning effect, this improves the sealing between the valve and seat.

Place the valve securing plate (11) in position and secure with the two screws (12).

Place the filter gauze (5) in position on top of the casting, making certain that it fits snugly.

Fit the cork washer, cover and retaining screw as

previously detailed under "Cleaning Filter" and detailed on page C/13.

To assemble the lower half of the pump, proceed as follows:—

Assemble link (22), packing washers (19), rocker arm (20) and rocker arm spring (21) in the body (16).

Insert the rocker arm pin (17) through the hole in the body, at the same time engaging the packing washers, link, and the rocker arm; then spring the retaining clips into the grooves on each end of the rocker arm pin.

The rocker arm pin should be a tight fit in the body, and if, due to wear, it is freer than this, the ends of the holes in the body should be burred over slightly.

**Note.** The fitting of the rocker arm pin can be simplified by first inserting a piece of .240-in. diameter rod through the pin hole in one side of the body far enough to engage the rocker arm washers and link, and then pushing the rocker arm pin in from the opposite side, removing the temporary rod as the pin takes up its proper position.

To fit the diaphragm assembly to the pump body:—

Place the diaphragm spring (23) in position in the pump body.

Place the diaphragm assembly (24) over the spring, the pull rod being downwards, and centre the upper end of the spring in the lower protector washer.

Press downwards on the diaphragm at the same time turning the assembly to the left in such a manner that the slots in the pull rod will engage the fork in the link, ultimately turning the assembly a complete quarter turn to the left. This will place the pull rod in the proper working position in the link and, at the same time, permit the matching up of the holes in the diaphragm with those on the pump body flanges.

When first inserting the diaphragm assembly into the pump body, the locating "tab" on the outside of the diaphragm should be at the 11 o'clock position. After turning the diaphragm assembly a quarter turn to the left the "tab" should be at the 8 o'clock position. These positions are shown in Fig. 17.

The two sub-assemblies of the pump are now ready for fitting together, and this is carried out as follows:—

Push the rocker arm (20) towards the pump until the diaphragm is level with the body flanges.

Place the upper half of the pump into the proper position as shown by the mark made on the flanges before disassembling.

Install the cover screws and lock washers, and tighten only until the heads of the screws just engage the washers.

Release and push the rocker arm away from the pump so as to hold the diaphragm at the top of the stroke and, while so held, tighten the cover screws diagonally and securely.

### Testing the Pump

The best method is by using an A.C.-Spring bench test stand, on which the suction side of the pump is piped to a tin of paraffin at floor level and the outlet side of the pump connected to a stop tap and pressure gauge.

First flush the pump through to wet the valves and seats, and then completely empty it again by continuing to operate the rocker arm by hand with the suction pipe clear of the paraffin. Again operate the pump. Not more than 20 strokes should be necessary to secure delivery of paraffin from the pump outlet.

With the same apparatus a second test can be made by working the pump with the tap on the delivery side closed, pressure then being recorded on the gauge. After ceasing to work the pump it should take several seconds for this pressure to return to zero, thus denoting that the valves are seating properly. Also, while there is pressure, the outer edge of the diaphragm visible between the two clamping flanges should be carefully examined for leakage and the retaining screws tightened if necessary. When working a pump by hand a somewhat longer stroke is obtained and the pressure developed is apt to be higher than when fitted to the engine.

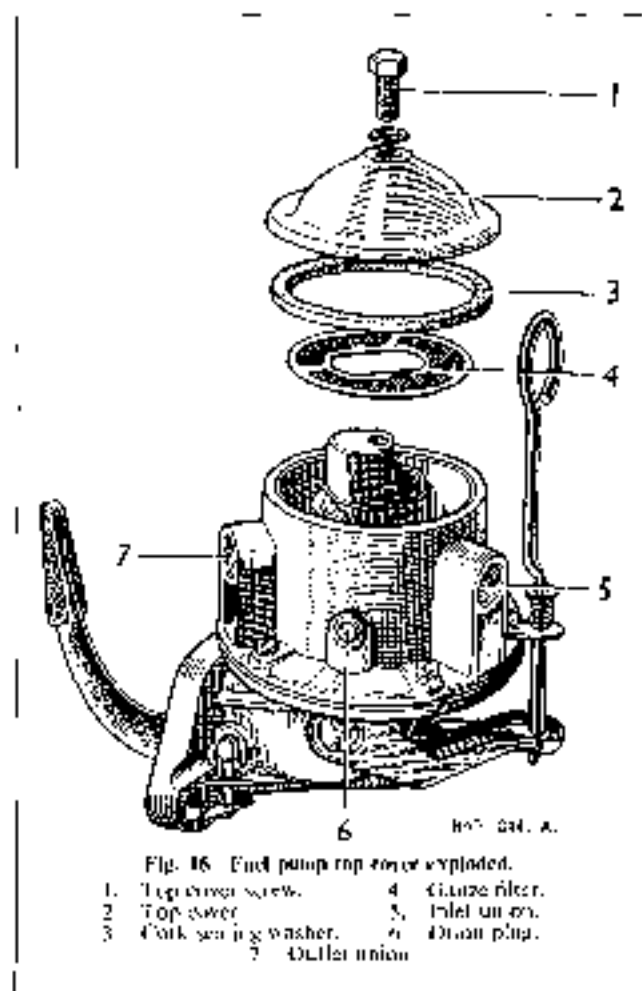

Fig. 16 Fuel pump top cover exploded.

- |                         |                    |
|-------------------------|--------------------|
| 1. Top cover screw.     | 4. Gauge filter.   |
| 2. Top cover.           | 5. Inlet union.    |
| 3. Cork sealing washer. | 6. Diaphragm plug. |
| 7. Outlet union.        |                    |

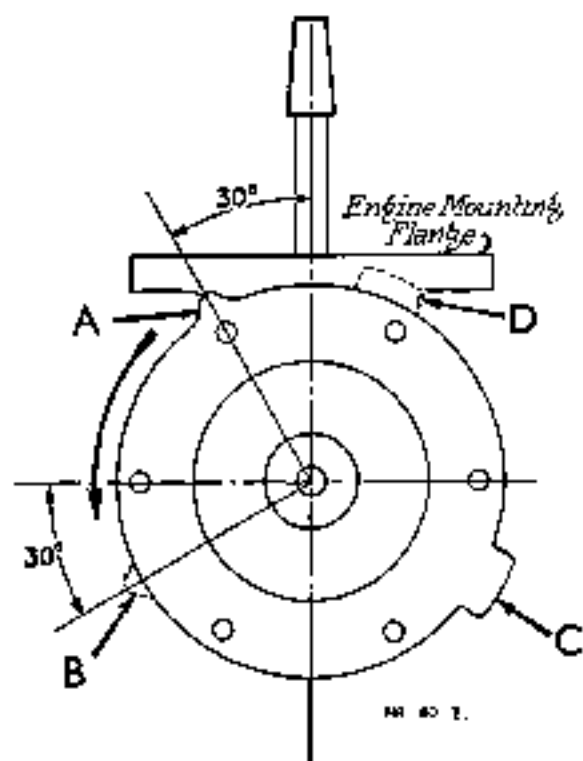

Fig. 17. When fitting the diaphragm to the pump body, the locating tab (A) on the diaphragm must be in the position shown. After engaging the notches in the bottom of the pull rod, with the slot in the link, turn the diaphragm until the tab is at position (B). This is done by gripping tab (C) and moving it to position (D).

When the above apparatus is not available the pumps should be tested, using a pan of clean paraffin, as follows:—

First flush the pump by immersing it in the paraffin and working the rocker arm half a dozen times; then empty the pump by continuing to operate it while held above the bath. Then, with the pump clear of the paraffin bath, place the finger over the inlet union (marked "in") and work the rocker arm several times. Upon removing the finger a distinct suction noise should be heard, denoting that the pump has developed a reasonable degree of suction. Afterwards the finger should be placed over the outlet union and after pressing the rocker arm inwards the air drawn into the pump chamber should be held under compression for two or three seconds; this should also be done with the pump immersed in paraffin and the clamping flanges of the diaphragm watched for any signs of air leakages.

#### Re-fitting to the Engine

Reverse the procedure outlined for removal from the engine. Ensure that the rocker arm is correctly positioned against the eccentric on the camshaft, as there is a possibility of inadvertently getting the rocker arm under the eccentric or to one side, when damage will result after the pump bolts are tightened. The joint washer between the pump and the crankcase should be renewed if unsound.

After re-fitting to the crankcase, the engine should be run for a short time, and the pipe unions and pump examined for any possibility of fuel leakage.





# ENGINE

**D**URING the early part of its life the working parts of an engine settle down with the result that various elements and adjustments need to be corrected. Thereafter, to obtain maximum efficiency, the engine should be treated with due respect and afforded its regular maintenance at the prescribed intervals.

## GENERAL DATA

Crankshaft and Bearings	... ..	.500 $\frac{1}{2}$ to .002-in. (.01905 to .0508-mm.)
Crankpins and Big End	... ..	.000 $\frac{1}{2}$ to .001 $\frac{1}{2}$ -in. (.0963 to .0381-mm.)
Gudgeon Pin to Piston	... ..	... .. <b>Thumb Fit</b> at 70°F. (21°C.)
Camshaft and Bearings	... ..	.001 to .002-in. (.0254 to .0508-mm.)
Camshaft End Clearance or Float	... ..	.002 to .008-in. (.0508 to .2032-mm.)
Crankshaft End Clearance or Float	... ..	.002 to .003-in. (.0508 to .0762-mm.)
Thrust	... ..	Taken by thrust washers on centre main bearings.
Side Clearance Connecting Rod and Crankshaft	... ..	.008 $\frac{1}{2}$ to .012 $\frac{1}{2}$ -in. (.2159 to .3175-mm.)
Crankshaft Diameter of Journals	... ..	1.8749 to 1.8754-in. (4.7631 to 4.7634-cm.)
Diameter of Crankpins	... ..	1.7499 to 1.7504-in. (4.4446 to 4.4591-cm.)
Valve Tappet Clearance	... ..	... .. .015-in. (.381-mm.)
Piston Fit	... ..	.015-in. (.381-mm.) at top land; .0012-in. (.0304-mm.) at skirt.
Piston Ring Gap	... ..	.008 to .012-in. (.2032 to .3048-mm.)

Undersized bearings of .020-in. (.508-mm.) and .040-in. (1.016-mm.) are listed. The crankshaft regrinding sizes for undersize bearings are tabulated below.

Undersize of Bearing	Regrinding Sizes			
	Crankpins		Journals	
	Minimum	Maximum	Minimum	Maximum
.020-in. (.508-mm.)	1.7299-in. (4.3938-cm.)	1.7104-in. (4.3951-cm.)	1.8549-in. (4.7113-cm.)	1.8554-in. (4.7126-cm.)
.040-in. (1.016-mm.)	1.7039-in. (4.3440-cm.)	1.7104-in. (4.3443-cm.)	1.8349-in. (4.6605-cm.)	1.8354-in. (4.6618-cm.)

### Cylinders and Crankcase

The cylinders are of the cast iron monobloc type with the crankcase being an integral part of the block. The cylinder bore diameter is 2.578-in. (6.5479 cm.). The maximum permissible rebore is the diameter  $\pm \frac{1}{2}$ -in. (1.5875 mm.).

### Cylinder Head

The head is of cast iron construction and is secured to the block by eleven  $\frac{1}{2}$ -in. (12.7 mm.) high tensile steel studs. Between the cylinder head and cylinder block is fitted a copper armoured hard clay board washer which has a compressed thickness of

.053 in. (1.3462 mm.). Torque wrench loading for cylinder head nuts = 40 lbs. ft. (5.53 kpm.).

### Crankshaft

The counter-balanced crankshaft is of forged steel and has three main bearing journals.

### Main Bearings

Each of the three main bearing shells are of steel construction and are fitted with linings of white metal. The crankcase walls are recessed to locate each end bearing cap, whilst the centre main bearing has a thrust washer at each side to take end thrust.

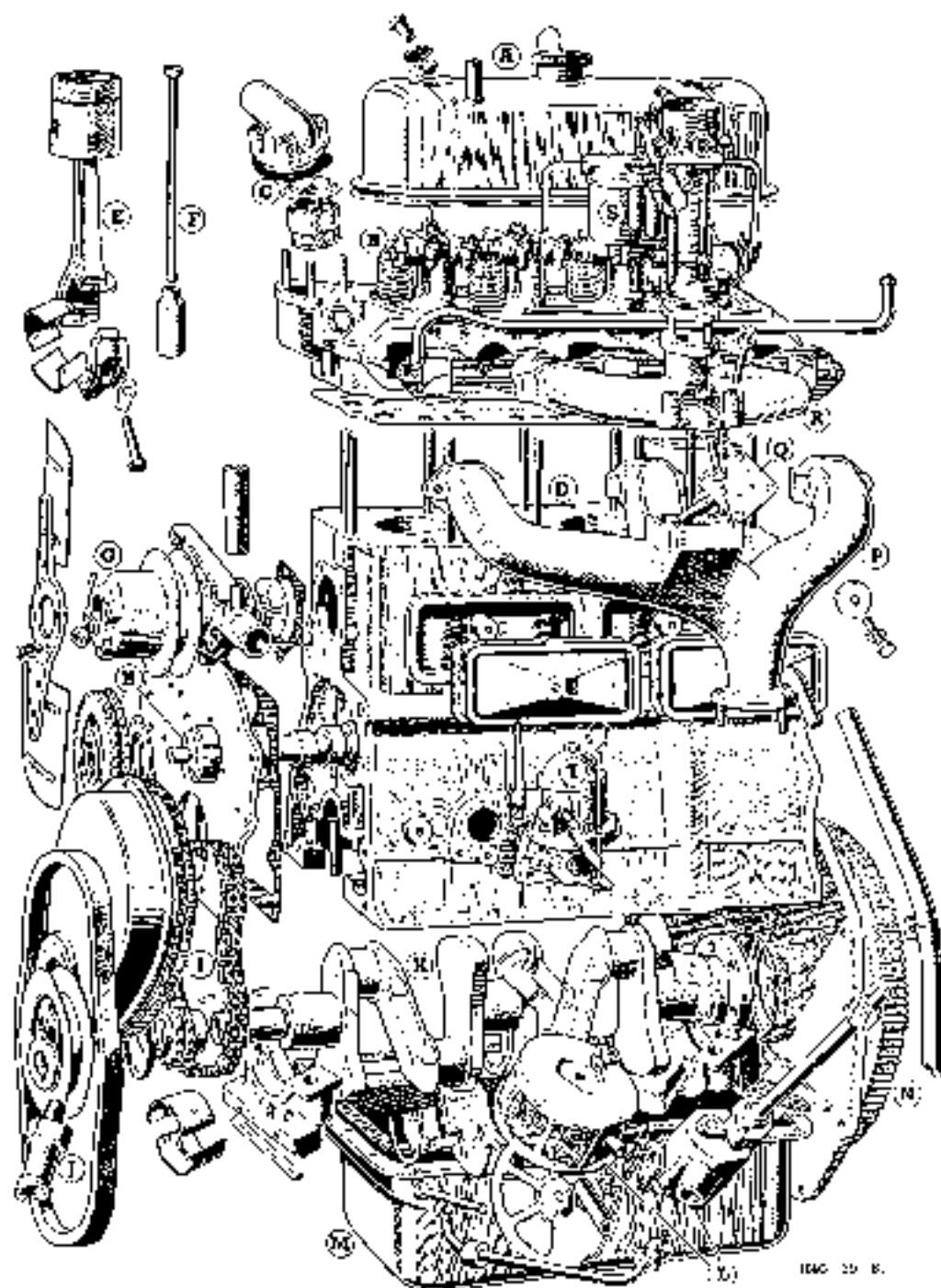

Fig. 1. An exploded view of the engine.

- |  |                                    |
|--|------------------------------------|
| A. Valve rocker cover.                         | K. Crankshaft bearing caps.        |
| B. Cylinder head assembly.                     | L. Oil pump and strainer assembly. |
| C. The piston.                                 | M. Oil sump.                       |
| D. Crankcase.                                  | N. Flywheel.                       |
| E. Piston and connecting rod assembly.         | Y. Exhaust manifold.               |
| F. Push rod and tappet.                        | Q. Hot spot.                       |
| G. Fat and water pump assembly.                | R. Induction manifold.             |
| H. Camshaft and crankshaft gear.               | S. Carburettor.                    |
| I. Timing gear cover and timing chain.         | T. Fuel pump.                      |
| J. Starting nut, pulley, fan and dynamic belt. |                                    |



### Connecting Rods

The connecting rods are of "H" section steel stampings and employ detachable "Thinwall" bearings, the caps of which are secured by two H.T. steel bolts. The small end is fitted with a clamping bolt to secure the gudgeon pin. Torque wrench loading for connecting rod nuts 33 lbs. ft. (4 562 kgm.).

### Gudgeon Pin

Of tubular section, the gudgeon pin is grooved to take the connecting rod clamping bolt. At 70 F. (21.1°C.) the pin should be a push fit into the piston boss.

### Pistons

The split skirt type pistons are of aluminium alloy with anodised finish and the lower ring groove is drilled for oil return.

### Piston Rings

The two compression rings and one oil control ring are situated above the gudgeon pin.

Ring gap . . . . .008-.012-in. (.2032-.3048 mm)

Groove width:

Compression... .095-.095½-in. (2 413-2 4257 mm.)

Oil Control ... .1577-.1582-in. (.40055-4 0182 mm.)

Groove Clearance:

Compression... .0012-.0017-in. (.0304-.0685 mm.)

Oil Control ... .0025-.0030-in. (.0635-.0762 mm.)

The latest models have four ring pistons—1 plain, 2 taper and 1 oil control.

### Camshaft

Three white metal lined steel shell bearings support the one-piece forged steel camshaft on the left-hand side of the engine. Chain driven from the crankshaft, the camshaft incorporates a spiral gear to drive the oil pump and distributor shaft, and an eccentric cam for operating the fuel pump. The end float of .002-.008-in. (.0508-.2032 mm) is controlled by a bronze flange at the rear of the camshaft gear. The camshaft drive employs a patent tensioned gear with Duplex roller chain, .375-in. (9 525 mm.) pitch, 52 pitches.

### Overhead Valves

The inlet valve is of Silicon Chrome Steel and the exhaust of XH steel. Each valve has a single coil spring retained by a cup and split cone collets, the latter being grooved externally to locate a safety clip. Both inlet and exhaust valves have a seat angle of 45 deg. whilst the seat width of the inlet valve is ¼-in. (1 5875 mm.) and the exhaust valve ⅜-in. (3 175 mm.). Valve guides are fitted having a stem clearance of .0015 to .0025-in. (.0381 to .0635 mm.) for the inlet and .0015 to .0019-in. (.0381 to .0482 mm) for the exhaust valves.

### Valve Gear

Tappets and push rods operate bushed rockers on a hollow shaft with an adjusting screw for valve clearance

on each push rod end. Side play of the rockers is controlled by four coil springs.

### Valve Timing

Both the crankshaft gear and the camshaft gear are spot marked for valve setting; the inlet valve opens 5 deg. before T.D.C.

The inlet valve of No. 1 cylinder must be timed to open 5° before top-dead centre, the equivalent of which on the flywheel is a point ¼-in. (1.27 cm.) before T.D.C. on a diameter of 11½-in. (28 7337 cm.), tappets being set to .021-in. (.5334 mm.) before testing. These should be re-adjusted to .015-in. (.381 mm.) afterwards for normal running.

### Flywheel

The flywheel, which has a diameter of 11½-in. (28 7337 cm.), is bolted to the crankshaft flange and the starter ring is of hardened steel with 117 teeth, the diameter over the teeth being 11.786-in. (29 9764 cm.) and is shrunk on to the flywheel.

### Induction and Exhaust Manifolds

The induction and exhaust manifolds of the Saloon model range are separate castings. They are bolted together at a central flange, at which point a special design of "hot spot" is incorporated. The combined assembly is attached to the monobloc by clamping washers, studs and nuts.

When assembling the manifolds to the cylinder head, the point is stressed that the manifolds should be pulled up tight to the head before tightening the common central flange bolts, this avoids the possibility of distortion.

In respect of the Sports there is no common induction manifold or "hot spot". Each of the twin carburettors leads direct to the cylinder head through junction pipes which are secured in place by the inner nuts and clamping washers of the exhaust manifold studs. These two junction pipes are connected to each other by a single pipe, fitted to balance the gas pressure in the inlet ports.

The exhaust manifold is a three way pipe with the centre pipe being the larger and covering two exhaust ports.

### Lubrication System

The forced feed lubrication is provided by a spur gear pump, situated in the sump, and driven by a vertical shaft from the camshaft. Oil is drawn through a strainer in the sump and forced under pressure to the main, big-end, camshaft and the valve rocker shaft bearings. An external by-pass filter is fitted on the right-hand side of the engine.

The crankcase is vented to the atmosphere in the engine side cover.

### Expansion Plugs (or Welch Plugs)

Four expansion plugs are fitted in the cylinder block. To remove a plug, drill a hole in the centre and lever out the plug with a screw-driver or other suitable tool.

It is usual in fitting a new plug to coat the edge with a jointing compound before inserting. (The "bulge"

must of course be on the outside when a plug is put in position.) A carefully aimed blow at the centre with a small hammer direct or with a blunt punch will expand the plug sufficiently to make a water-tight joint. If too heavy a blow is used the plug will be useless and must be replaced by another new one.

## LUBRICATION

**L**UBRICATION is of vital importance to ensure the reliability and long life of the moving parts. The chart given in Section T should be referred to for details of mileage application and grade of lubricant required. Additives which dilute or otherwise impair the efficiency of the oil must not be used, neither should graphite compounds be mixed with the oil as they may interfere with the very fine jets used for lubrication of certain parts of the engine; also premature choking of the oil filter may result.

### Description

There is full pressure lubrication throughout the unit. The gear type pump draws oil from the sump through a gauze filter and delivers it to all bearings and the crankshaft main.

The sump capacity is 7 pints (3.937 litres) including the by-pass filter which is fitted to the right-hand side of the engine.

The oil filter is in the valve rocker cover on top of the cylinder head and the oil level is checked by a dipstick situated next to the filter.

### Draining the Sump

The engine should be completely drained and fresh oil put in at least every 2,000 miles (3,200 km.) to provide the best possible running conditions.

On new or reconditioned engines, the oil should be changed after the first 500 miles (800 km.) running and again after the next 2,000 miles (3,200 km.).

Draining should be carried out when the engine is warm and under no circumstances should petrol or paraffin be used for flushing out the engine.

The drain plug is in the base of the sump.

### Refilling

When refilling the engine, do not pour the oil in too fast, or it may overflow. Also check that the tube which is connected to the air cleaner of the carburettor is not choked. Failure to keep this clear may result in condensation on the valve gear.

After filling, test the oil level with the dipstick, see Fig. 2, wiping the stick clean before taking the reading. This should only be done when the vehicle is on level ground and not immediately after the engine has been run, or a false reading may be given.

### Circulation

The oil circulation is clearly shown in Section T. Starting at the gauze filter and pick-up in the sump, oil is drawn into the pump from which it is led to the main oil gallery and to the filter. This runs the length of the engine on the right-hand side and from it the main oil delivery is made. A spring-loaded or release valve is located between the pump and the main gallery, which

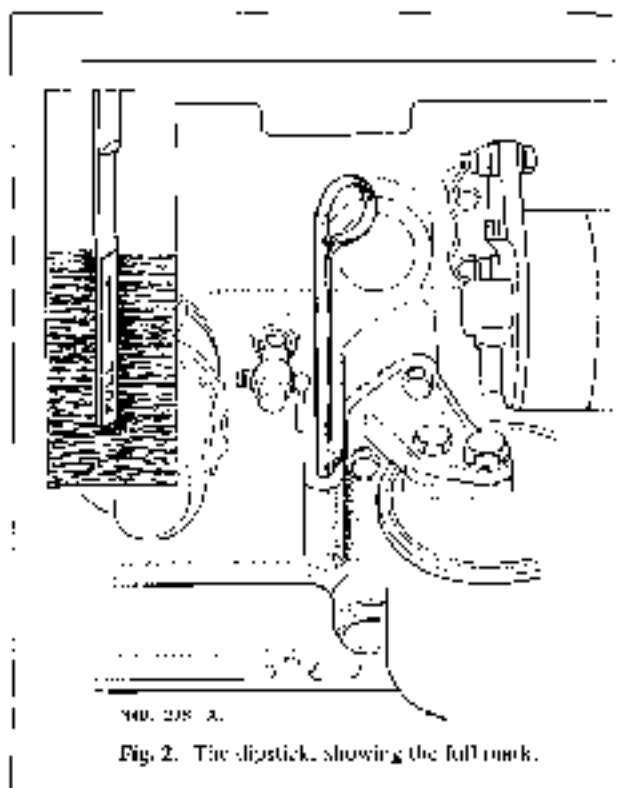

Fig. 2. The dipstick, showing the full mark.

is accessible from the exterior of the crankcase, see Section T; the overflow from this valve is returned to the sump. From the main gallery oil is fed to the main bearings, big ends, and the three crankshaft bearings. Each tappet is lubricated from a small oil gallery which runs the length of the engine on the left-hand side.

From one crankshaft bearing oil at reduced pressure is taken through drilled passages in the cylinder block and cylinder head to an oil feed collar on the valve rocker shaft and thence to the drilled shaft itself. Therefore the shaft is under pressure, surplus oil, after circulation, returning from the rocker gear via the push rod holes to the sump.

At the front end of the front crankshaft bearing there are two oil bleed holes which feed oil to the crankshaft gear and thence to the timing chain. Separate lubrication for the cylinder boxes is effected by a small jet hole in the top half of each connecting rod big end bearing.

### Oil Pressure Gauge

The oil gauge gives an indication whether the oiling system is working properly. The normal pressure during ordinary running should be between 40-45 lb. per square inch (2.812 to 3.164 kg./cm.<sup>2</sup>), with a proportionate lower pressure when idling.

The gauge should be observed when the engine is first started up after refilling the sump to check that the oil is circulating and that the pressure is correct. It should also be kept under observation frequently during normal running. Should the gauge fail to register a normal pressure, it may be due to lack of oil in the crankcase. If oil is present and the gauge still fails to register, stop the engine immediately and check for a broken pipe or other cause. Test the gauge by a replacement, plugged direct to the instrument panel.

### Check for Loss of Pressure

First check the sump oil level by means of the dipstick. If the level is well up check the oil gauge pipe from the crankcase to the instrument panel for fracture or leak. If the pipe is in order remove the sump and examine the gauge filter. This may be choked; also remove the release valve and inspect for signs of foreign matter on the valve seat.

If these tests fail to indicate the cause of the loss of pressure or oil circulation, the crankshaft and other bearings will have to be closely examined and stripped down if necessary.

### External Filter

It will be appreciated that the external filter plays an important part in maintaining the cleanliness of the engine oil and so prolonging the life of the engine. The filter must therefore be replaced complete at the end of its effective life, which is approximately 6,000 miles (7,200 km.). It is recommended to mark the date and mileage on the casing of the replacement unit, the correct unit being A.C. type ARK or Parafilter Micronic type MF 2001.

The filter cannot be stripped for examination.

Make sure that the filter is bolted securely to the crankcase and that the joint washer is in a sound condition.

### Testing the Filter

When the engine is at a working temperature, with the engine running at a moderate speed, slacken the centre oil union which is the outlet. Oil should flow steadily from the union. If the flow is intermittent a faulty filter is indicated.

If it is found that no oil is circulating through the filter, the inlet union and its connection should be

checked. This union may be choked with dirty oil. Always make sure that they are perfectly free from obstruction when fitting a new filter.

### Removing the Filter

The external oil filter is secured to the crankcase by a mounting bracket which has drilled oil passages for oil feed and return.

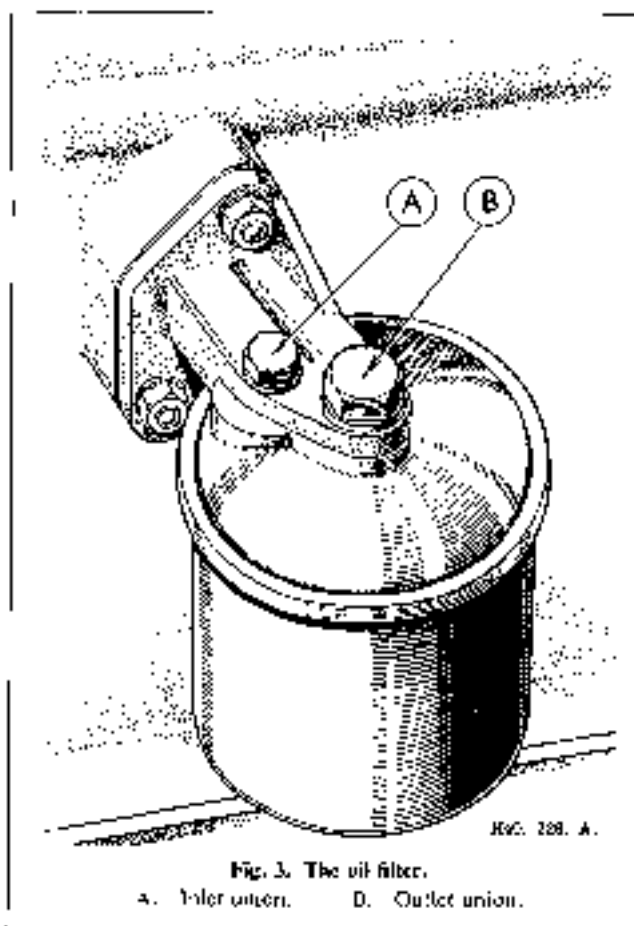

Fig. 3. The oil filter.

A. Inlet union. D. Outlet union.

To remove the oil filter, withdraw the small and large union setpins which pass through the bracket into the head of the filter. Under the heads of the union setpins there are separate joint washers and between the filter top and the mounting bracket there is a common joint washer. All three washers should not be used a second time unless they are completely free from damage, otherwise leaks may occur when the new filter is secured in place.

By removing the bracket from the crankcase—two setpins—before the new filter is fitted, the oilways in the bracket can be checked to ensure that they are free from obstruction and absolutely clean on the joint faces.

### Removing the Oil Sump

First, drain off the oil by taking out the drain plug; the oil capacity is approximately 7 pints including the external filter.

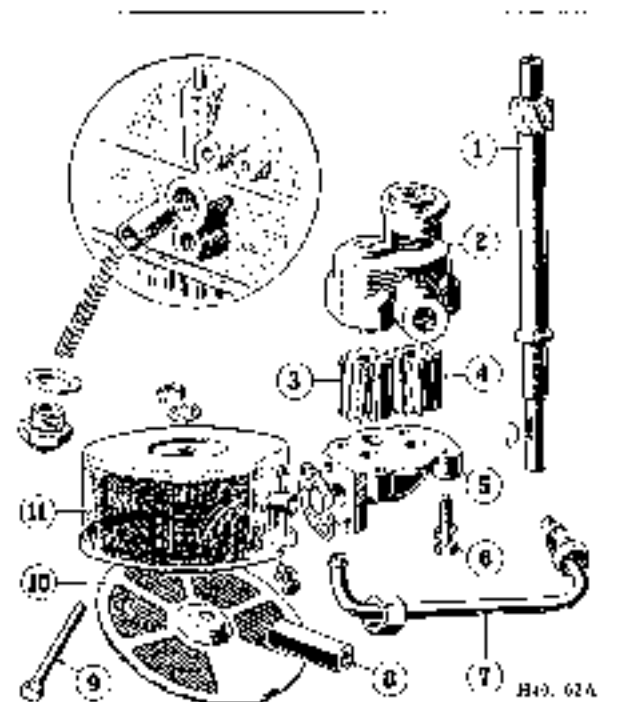

Fig. 4 Details of the oil pump assembly.

- |                     |                         |
|---------------------|-------------------------|
| 1. Driving spindle. | 6. Setscrew and washer. |
| 2. Oil pump body.   | 7. Oil delivery pipe.   |
| 3. Driven gear.     | 8. Distance piece.      |
| 4. Driving gear.    | 9. Setscrew.            |
| 5. Bottom cover.    | 10. Bottom cover.       |
|                     | 11. Oil strainer body.  |

Inset shows the release valve assembly.

The pump is secured in position by 17 setscrews and one bolt and nut. Support the pump while removing these screws and then lower clear of the oil pump gauze strainer and pick-up.

Remove the joint washer. If this is broken or damaged it will have to be replaced on reassembly.

#### Gauze Strainer and Pick-up

The strainer should be examined for contamination and removed if necessary by releasing the centre screw 9, Fig. 4, and the two screws holding the strainer to the pump body.

Wash the gauze with paraffin, using a brush.

#### Removing the Oil Pump

Disconnect the oil supply pipe from the pump body to the crankcase.

From the upper flange of the oil pump remove the two nuts and spring washers. The oil pump complete can now be drawn down out of the crankcase.

#### Dismantling and Reassembling the Pump

The pump body, Fig. 4, is in two pieces; before dismantling mark the two flanges to assist in reassembly.

Remove the four long setscrews from the body, separate the bottom cover and lift out the driven gear. The driving gear is keyed to the spindle and will need to be tapped off.

Remove the key from the spindle which can then be withdrawn from the pump body. Check that the driving key is a good fit both in the spindle and the driving gear. On reassembly, with gears in position and the bottom cover bolted up, the pump must be perfectly free from stiffness when rotated by hand.

#### Replacing the Oil Pump

Insert the pump from below and push the shaft right home, when the driving gear will mesh with the gear on the crankshaft. Replace the two spring washers and nuts on to the studs now protruding through the top flange of the oil pump and tighten up securely. Reconnect the gauze filter and the main oil delivery pipe to the pump body and crankcase. The pump does not need to be primed.

#### Release Valve

Release valve pressure is determined by the spring, which is held in position by a hexagonal headed plug. This plug is screwed home and no adjustment is provided. (See inset, Fig. 4.)

The valve is a conical-faced hollow plunger. Check that the plunger and the valve seat are clean and undamaged and that the passages in the crankcase are clear of foreign matter.

When reassembling make sure that the fibre washer is fitted under the head of the valve plug, and that an oil-tight joint is made.

#### Valve Rocker Shaft

The valve rocker shaft on the cylinder head is hollow. It is supplied with oil by a pipe connection and is drilled for lubrication of each rocker bearing. The shaft is plugged at each end, one of these being screwed in and secured by a split pin. It is thus detachable, to enable the shaft to be cleaned internally. (See Fig. 5.)

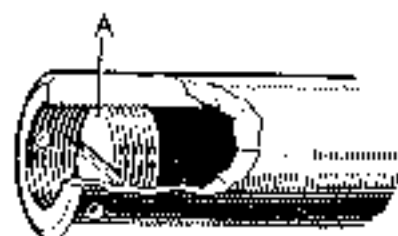

Fig. 5.

Showing the screwed plug A to facilitate the internal cleaning of the rocker shaft.

## SERVICE OPERATIONS WITH ENGINE IN POSITION

### Valve Mechanism

The overhead valve operating mechanism of this engine is of normal design, incorporating an oil feed under pressure from the main oil gallery to the rocker shaft. From which oil passes to each rocker and its adjusting screw.

The complete rocker gear can be removed for examination without releasing the cylinder head. The valve rocker cover should first be removed and then the oil feed disconnected. This is followed by the removal of the nuts and washers holding each rocker shaft bracket to the cylinder head. The complete assembly can now be removed. Replacement is a reversal of the above procedure.

### Adjusting the Valve Clearance

Lift the valve cover after removing the air cleaner and two special cap nuts. Between the rocker arm and the valve stem there must be a clearance of .015-in.

To check this adjustment have the engine turned by the starting handle and note the point at which the push rod stops falling. From this point until it starts to move again there must be a clearance of .015-in. Test with feeler gauge.

If adjustment is necessary, whilst continuously applying sufficient pressure to the adjusting screw with a heavy screwdriver, slacken the locknut and raise or lower the adjusting screw in the rocker arm.

Tighten the locknut when the adjustment is correct, but always check again afterwards in case the adjustment has been disturbed during the locking process. It is most advisable that this recheck of the clearance be

made while the engine is at normal working temperature.

In replacing the valve cover take care that the joint washer, using a new one if necessary, is properly in place to ensure an oil-tight joint and then refit the air cleaner.

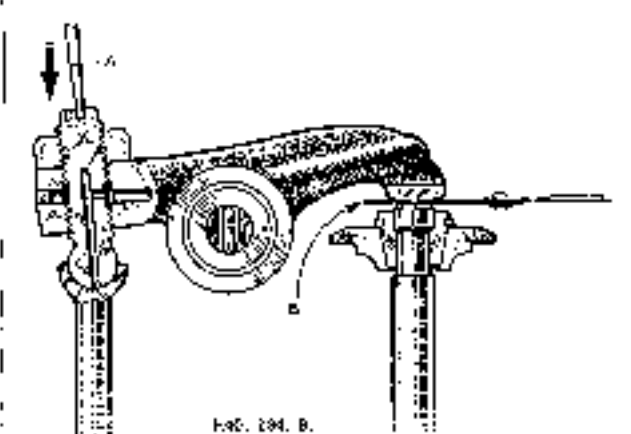
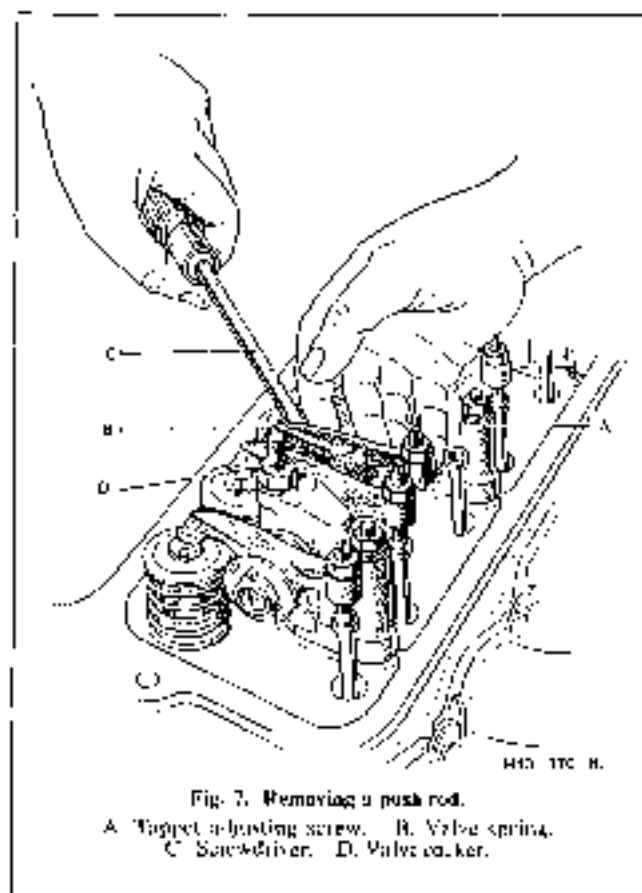

### Removing the Push Rods

To remove the push rods (see Fig. 7) it is not necessary to dismantle the valve gear beyond slackening the tappet adjustment.

Take off the two cylinder side covers.

Slacken the tappet adjustment screw to its full extent. With the aid of a screwdriver, supported under the rocker shaft, depress the valve and spring and then slide the rocker sideways free of the push rod. Withdraw the push rod.

In respect of the front or rear end rocker, however, it is necessary to take out the split cotter pin from the end of the shaft, when the rocker can be removed, together with the plain washer (Fig. 7).

Replace in reverse order.

Fig. 8. The right hand side of the power unit showing:

1. Air cleaner clamp bolt.
2. Valve rocker gear/rocker pipe.
3. Valve rocker cover.
4. Heater control valve.
5. Vacuum fitting control.
6. Welch plug.
7. Distributor.
8. Cylinder drain tap.
9. Engine back plate.
10. Starter.
11. Dip stick.
12. Starter terminal.
13. Oil pump drain plug.
14. Oil filter.
15. Filter bracket.
16. Fan belt.
17. Dynamo pulley.
18. Sparking plug.

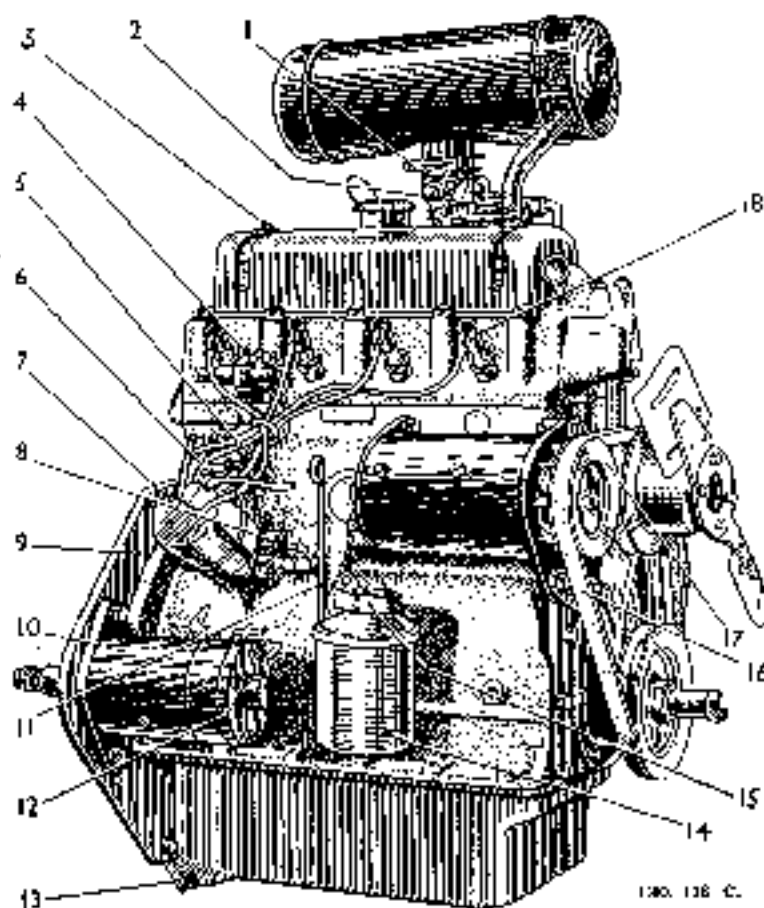

### Decarbonising

For this operation it will be necessary to remove the carburetter, manifolds, cylinder head and push rods.

Scrape off all carbon deposit from the cylinder head and ports (see valve grinding for access to ports).

Clean the carbon from piston crowns by scraping with a chisel-shaped piece of hardwood. Care being taken not to damage the piston crowns and not to allow dirt or carbon deposit to enter the cylinder barrels or push rod compartments.

When cleaning the top of the piston, do not scrape right to the edge, as a little carbon left on the chamfered edge assists in keeping down oil consumption; with the pistons cleaned right to the edge, or with new pistons, oil consumption is often slightly, though temporarily, increased.

### Removing the Cylinder Head

Drain all water from the radiator. If the water contains anti-freeze mixture it should be run into a clean container and used again.

Detach the top water hose from the cylinder head and disconnect the thermostat by-pass pipe (4, Fig. 10).

Disconnect the high tension wires from the sparking plugs; also remove the plugs.

Remove the carburetter.

Remove the exhaust and inlet manifolds (see section C, page 2).

Remove the valve rocker cover.

Remove the 11 nuts holding the cylinder head to the cylinder block.

Slacken back the tappet adjusting screws and remove the push rods.

Lift the cylinder head, best accomplished by using a sling under the rocker shaft; a rope is preferable to chains.

With the head on the bench, remove the rocker oil feed pipe (see 19, Fig. 13) and then the rocker brackets (note the position of the bracket which carries the oil feed pipe from the cylinder head). This will assist in replacing. There are two holding down nuts to each bracket.

Lift off the rocker gear complete.

### Replacing the Cylinder Head

Relit the cylinder head washer with the side marked "TOP" uppermost, having greased both sides with

grease to make a good joint and prevent sticking when the head is again lifted.

Replace the rocker gear if this has been removed.

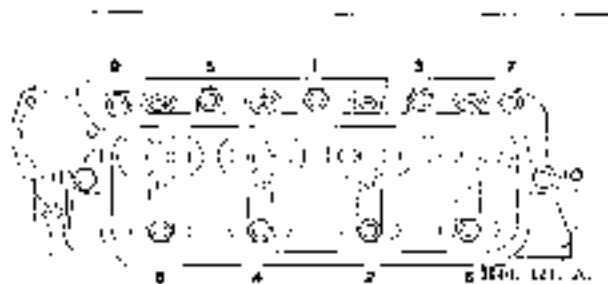

Fig. 9. Tighten cylinder head nuts from the centre and work outwards in order shown.

Lower the head over the studs, replace the cylinder head nuts finger tight, and insert the tappet push rods.

Tighten the cylinder head nuts evenly, a quarter of a turn at a time, and in the order shown in Fig. 9.

Reset the tappets to .015-in. and replace the valve cover.

Replace the manifolds and carburetter making sure that good joints are made, connect up the radiator and by-pass hose, replace the sparking plugs and high tension wires.

Refill the radiator.

Check the valve tappet clearance again after the vehicle has run about 100 miles (160 km.) as the valves have a tendency to bed down. At the same time it is advisable to test the cylinder head nuts for tightness. Tightening the cylinder head nuts may affect tappet clearances, although not usually enough to justify resetting.

### Valves

Weak compression in any cylinder, in spite of correct tappet clearances, usually suggests that valve grinding is necessary and the head should be removed for investigation.

Fig. 10. The left hand side of the power unit showing:

1. Valve rocker cover.
2. Heater outlet pipe.
3. Exhaust manifold nut.
4. By-pass pipe.
5. Water pump.
6. Tappet cover screws.
7. Starter nut.
8. Timing gear cover.
9. Fuel pump outlet union.
10. Fuel pump.
11. Exhaust flange studs.
12. Breather pipe connection.
13. Petrol drain pipe.
14. Inlet manifold.
15. Vacuum control pipe.
16. Throttle linkage.

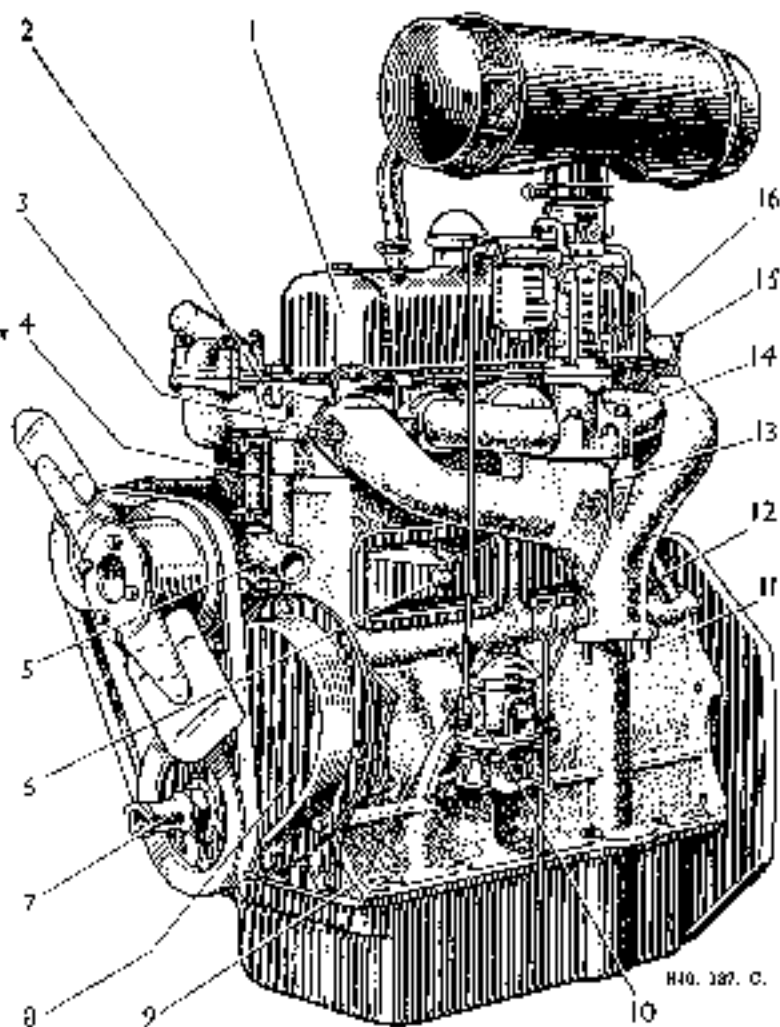

### Removing and Refitting a Valve

With cylinder head removed a valve lifting tool, as illustrated in Fig. 11, can be used to compress the spring.

Take away the circlip and the split cotters, then release the spring and remove the valve.

Split the two halves of the spring cup between which there is a rubber seal. If this seal shows any signs of damage or wearing, it should be renewed as its object is to prevent excess oil entering the valve guide.

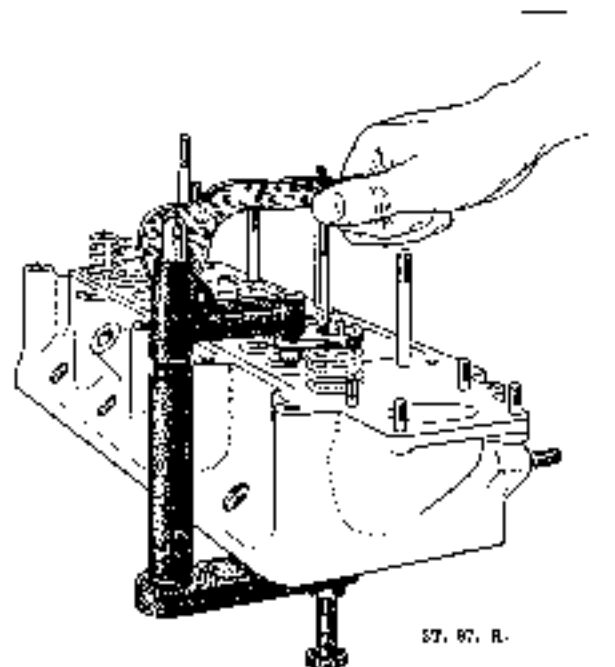

Fig. 11. Showing the valve, spring compressor, Service Tool 18G 45, in operation.

Reassembly is a reversal of the operations for removal. When fitting the split cotters it is worth noting that the spring circlip should be replaced as soon as the cotters are in position. This saves holding the cotters in the groove while the spring is released.

When removing the valves, place them on a valve carrying board to enable them to be identified as to the cylinders from which they have been taken. The valve springs should be tested. The free length being approximately 1 1/2-in. (2 60/32 cm.); replace if necessary.

Clean the carbon from the top and bottom of the valve heads, as well as any deposit that may have accumulated on the stems. The valve heads should, if necessary, be relaced at an angle of 45°. If the valve seats show signs of excessive pitting it is advisable to relace these also.

### Valve Seat Insert Removal

It will be found that on some reconditioned engines valve seat inserts have been fitted and their removal necessitates the use of Service Tool 18G 120.

As previously described, remove the valves and valve rocker mechanism from the cylinder head. Invert the head and place it on a suitable bench. Position the extractor (see Fig. 12) on the cylinder head (3), screw back the wing nut (2) so that the three legs (4) drop well inside the insert (5), then open them out by rotating the centre screw (1) until the tips of the legs engage with the underside of the insert.

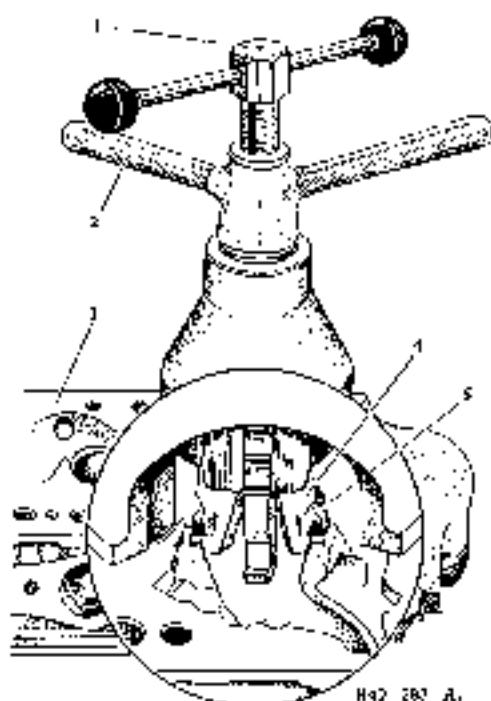
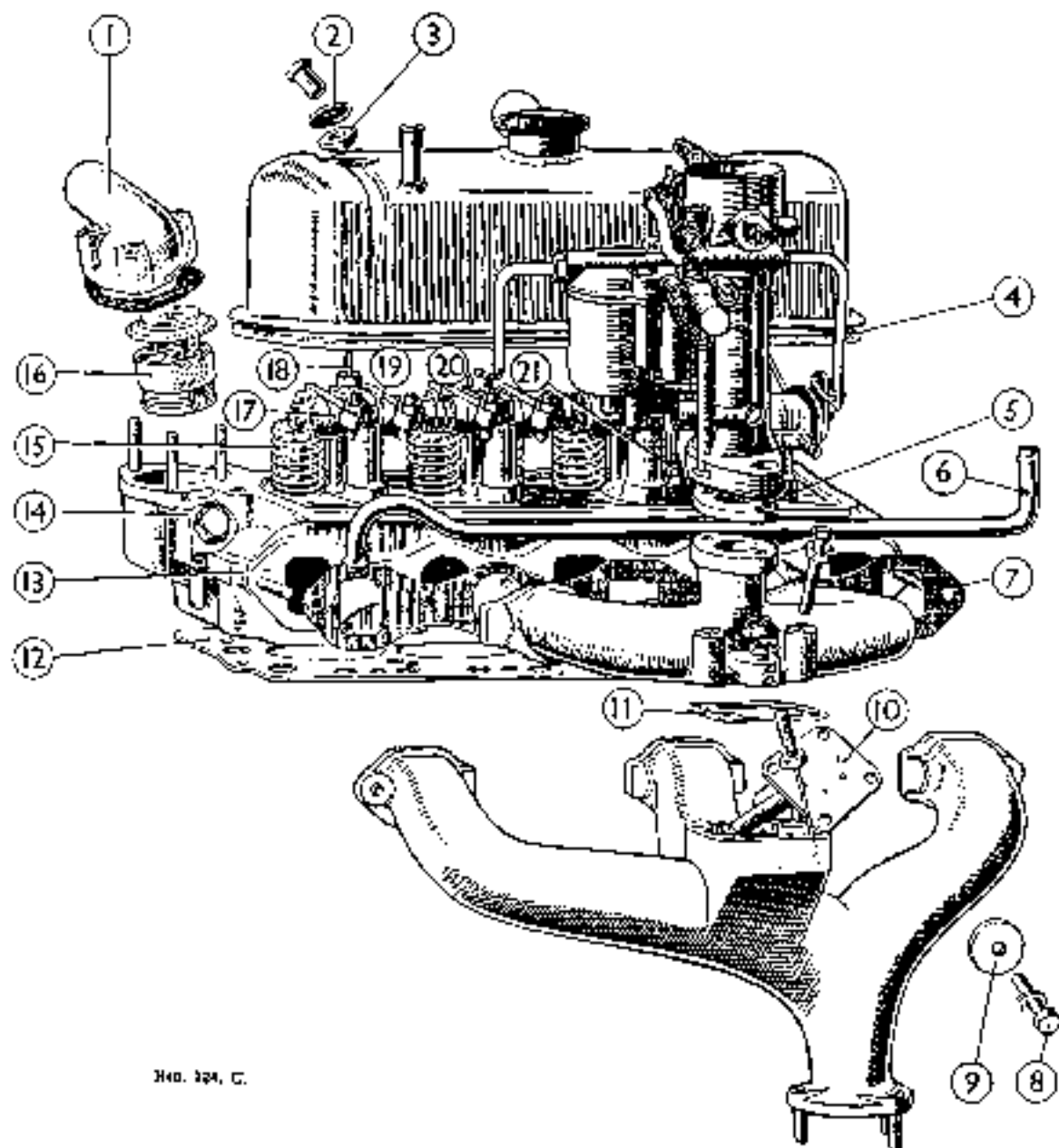

Fig. 12. The valve seat insert extractor, Service Tool 18G 120. 1. Centre screw. 2. Wing nut. 3. Cylinder head. 4. Legs. 5. Insert.

Place a cloth around the base of the extractor in case the insert should fracture, then operate the wing nut in a clockwise direction to withdraw the insert. After having removed all the carbon deposit from the cylinder head, fit the new inserts with the aid of a light press.

Reassemble the valves and valve rocker mechanism having first ground-in the valves. Finally refit the cylinder head to the engine.





Ref. 324, C.

Fig. 13. An exploded view of the cylinder head assembly.

- |                       |                          |                              |
|-----------------------|--------------------------|------------------------------|
| 1. Thermostat cover.  | 2. Serpentine washer     | 15. Valve spring             |
| 2. Cup washer         | 3. Yoke washer           | 16. Thermostat.              |
| 3. Rubber bush        | 4. Joint washer          | 17. Rocker arm.              |
| 4. Joint washer.      | 5. Joint washer          | 18. Valve rocker cover stud. |
| 5. Joint washer       | 6. Flange return pipe    | 19. Rocker shaft bracket     |
| 6. Flange return pipe | 7. Manifold gasket       | 20. Spring spring            |
| 7. Manifold gasket    | 8. Yoke washer           | 21. Oil feed pipe and union. |
|                       | 9. Yoke washer           |                              |
|                       | 10. Hot pipe             |                              |
|                       | 11. Joint washer         |                              |
|                       | 12. Cylinder head washer |                              |
|                       | 13. Cylinder head        |                              |
|                       | 14. Thermostat housing   |                              |

### Valve Grinding

For valve grinding a little grinding paste should be smeared evenly on the valve face and the valve rotated backwards and forwards against its seat, advancing it a step at short intervals, until a clean and unspitted seating is obtained. The cutting action is facilitated by periodically lifting the valve from its seat. This allows the grinding compound to re-penetrate between the two faces, after being squeezed out.

On completion all traces of compound must be removed from the valve and seating.

It is essential for each valve to be ground-in and refitted on its own seating as indicated by the number on the valve head. The valves are numbered 1 to 8, starting from the front. If a new valve is used it should be identified with its seating by stamping the number on the head, taking care not to distort the valve in the process.

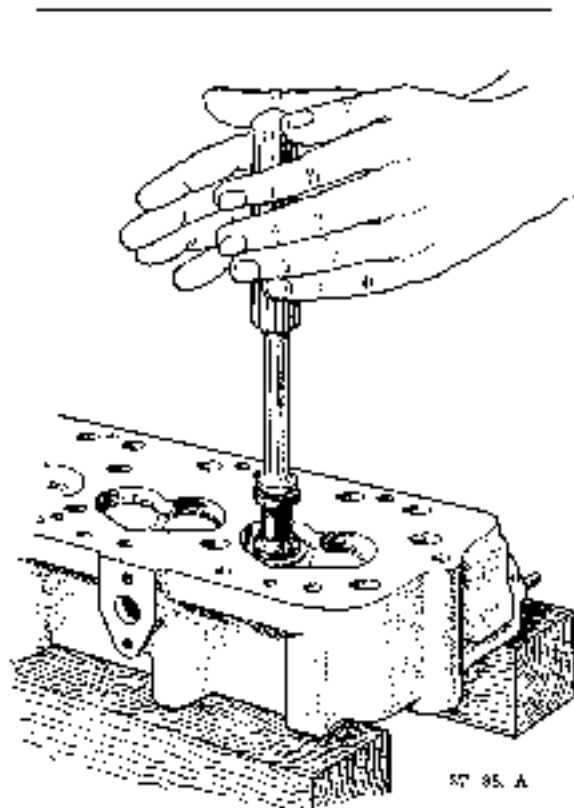

Fig. 14. The valve grinding-in tool (JRG 29).

It is also desirable to clean the valve guides. This can be done by dipping the valve stem in petrol or paraffin and moving it up and down in the guide until it is free. Re-clean the valve and re-insert in the guide, the valve spring, cup, cotter, and wireclip being fitted round it.

### Valve Guides

Although the valve guides are of one piece design, internally they are stepped to give three different diameters. Note: On later models only the exhaust valve is stepped.

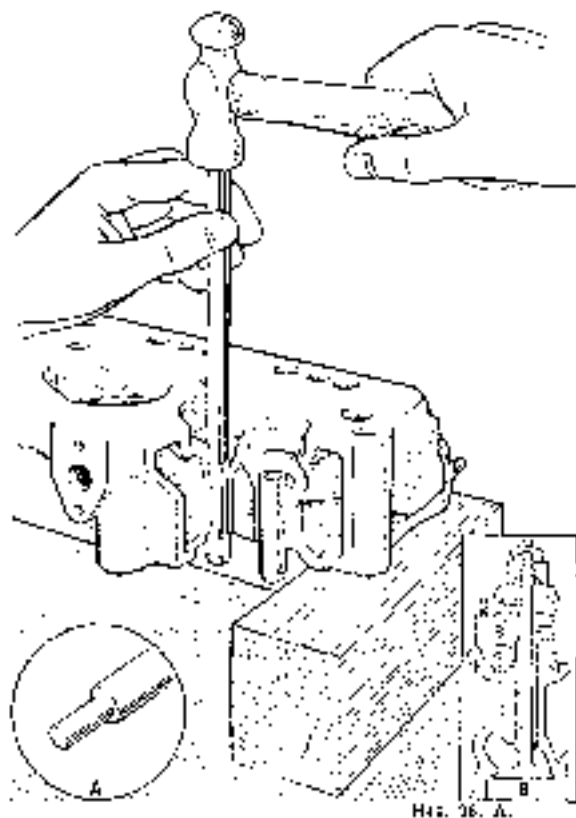

Fig. 15. Renewing a valve guide: A. Stepped drift; B. The final position of the guide above the cylinder head.

As the portion of the guide above the cylinder head has the greater freedom of expansion, it has the closer working fit to the valve stem, thus being able to restrict the flow of oil and gas between stem and guide.

Valve guides should be tested for wear whenever the valves are removed. If excessive side play is present a close inspection should be made of the valve stem and the guide. In the event of wear the defective component should be renewed. Valve wear will be evident on the stem, but it should be borne in mind that the valve stem and guide should be a running fit to avoid air leaks.

A defective valve guide may be driven out as shown in Fig. 15, having first removed the valve. Use a stepped drift, the point of which should be a good fit in the guide.

The new guide should be inserted through the top of the cylinder head and driven towards the valve seating with the aid of the above mentioned drift or a small hand press.

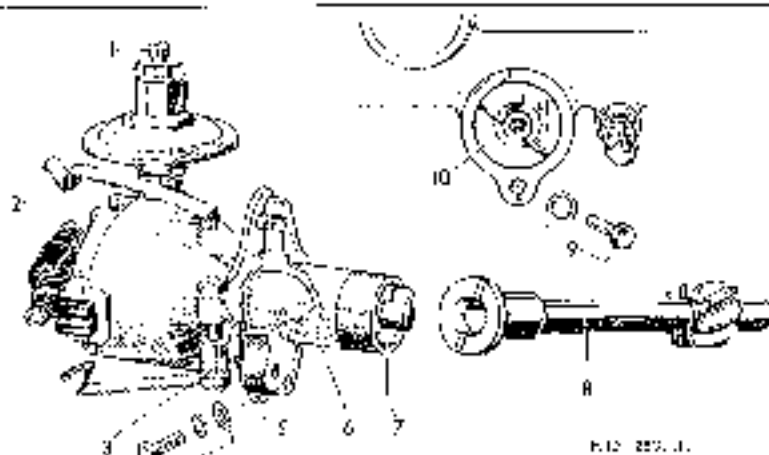

Fig. 16. An exploded view of the distributor drive.

1. Vacuum control minor.
2. Distributor.
3. Claws plate.
4. Claws plate setpin.
5. Bolt for clamp plate.
6. Distributor housing.
7. Driving dog.
8. Main drive spindle.
9. Setpin for housing.
10. Spindle end.

K.12 252 J.

The final position of the guide is shown in Fig. 15. It must stand  $\frac{1}{16}$ -in. (1.5875 mm.) above the valve spring recess in the cylinder head.

#### Renewing Valve Spring in Position

In an emergency a new valve spring can be fitted without lifting the cylinder head, but it is first advisable to bring the piston to top dead centre, thus preventing the valve falling into the cylinder.

Remove the sparking plug, and by means of a screwdriver or similar tool, the valve can be held on its seat whilst the spring is compressed. The valve rocker shaft can be used as a fulcrum point by an operator using two screwdrivers to bear on the valve spring cup each side of the valve stem while the cotters are dealt with.

#### Distributor. To Remove and Replace

Remove the distributor cover by releasing the two spring clips, then disconnect the low tension wire and the plug leads.

Disconnect the vacuum control suction pipe and slacken the pinch bolt of the distributor clamping plate. Lift out the distributor.

Under normal circumstances it will not be necessary to remove the main driving spindle. Should the occasion arise—such as a major overhaul when the camshaft has to be removed—simply remove the clamping plate by releasing two setpins and the distributor housing by releasing one setpin. Insert a length of screwed  $\frac{1}{8}$ -in. (1.9375 mm.) diameter rod in the end of the spindle. Withdraw the spindle at the same time giving the rod a turning movement to ease removal.

On replacement the engine must be turned until No. 1 piston is at T.D.C. on the compression stroke, i.e., Nos. 7 and 8 valves "racking".

With the screwed rod still in the distributor spindle, insert the spindle in the cracker so that the eccentric slot takes up a position of approximately

twenty past ten, the larger portion of the spindle flange being top right.

The key of the distributor drive coincides with the slot of the spindle thus ensuring that the distributor cannot be incorrectly refitted.

#### Ignition Timing

The correct setting for the Saloon, Coupé and Commercials, using standard fuel, is 7 deg. before T.D.C. ( $\frac{1}{16}$  in. on flywheel periphery) and, for premier fuel, 10 deg. before T.D.C. ( $\frac{1}{8}$  in. on flywheel periphery). For the Sports, using standard fuel, the setting is 2 deg. before T.D.C. ( $\frac{1}{16}$  in. on flywheel periphery) and, for premier fuel, 7 deg. before T.D.C. ( $\frac{1}{8}$  in. on flywheel periphery).

If the gearbox is removed obtain T.D.C. for No. 1 piston on compression stroke (Nos. 7 and 8 valves "racking") by turning the engine with the starting handle until the "1/4" mark on the flywheel is vertical. Make a corresponding mark on the engine backplate, also mark off on the flywheel the desired setting (already given for the fuel to be used). Now rotate the flywheel with the starting handle until on the second revolution the new setting mark coincides with the mark on the engine backplate.

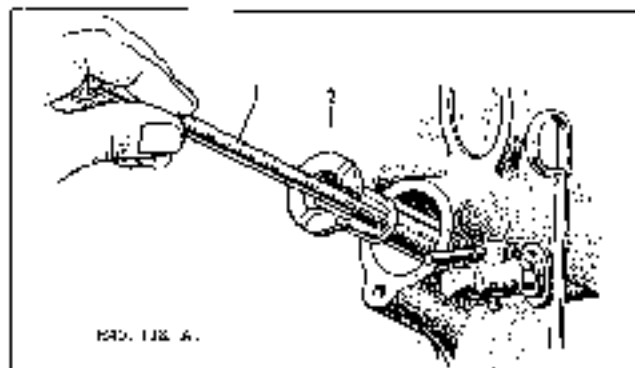

K.12 128 J.

Fig. 17. Showing the method of removing the distributor driving spindle.

1. Screwed rod.
2. Driving spindle.

However, with the gearbox in place a convenient method of obtaining the new firing position for No. 1 piston is to first of all remove all sparking plugs except No. 1. Using a piece of card, marked off in degrees, attached to the front bumper rotate the engine with the starting handle until T.D.C. of No. 1 piston, on compression stroke, is obtained. Note the position of the starting handle relative to the card, then with the handle still engaged with the same dog tooth of the crankshaft rotate the engine two revolutions less the required number of degrees.

Having obtained the correct position of the flywheel for No. 1 piston and with the distributor vernier set to zero, slacken the distributor clamping bolt. Rotate the distributor body until the rotor arm is at the correct position for No. 1 electrode in the distributor cap, again rotate the distributor body until the contact points just open. An effective method of ascertaining when the points are open is to connect a battery and a bulb in series with the contact points. When the points are closed the bulb will light, but will go out as the contacts open.

Re-tighten the clamping bolt and fit the distributor cap. Finally, connect the vacuum control pipe and replace the plug leads in the correct firing sequence of 1, 3, 4, 2. Test the car on the road, when a finer adjustment can be made at the distributor vernier adjustment knob.

### Sparking Plugs

The sparking plugs fitted to both the Saloon and Sports are of the long reach 14mm. type; Champion N8B for the Saloon range and Champion N8A for the Sports.

The gaps of these plugs should be maintained at .018-in. (.4572 mm.) for the Saloon and .025-in. (.635 mm.) for the Sports. If the gap is allowed to become too wide misfiring at high speeds is liable to occur; and if too small, bad slow running and idling will be the result.

Sparking plugs should be regularly inspected, cleaned and tested. This is of vital importance to ensure good engine performance coupled with fuel economy.

When removing the plugs from the engine use a box spanner; this will avoid possible damage to the insulator. Always remove the copper washer with the plug. They should then be placed in a suitable holder which has holes drilled to admit the upper end of the plugs and marked to identify each plug with the cylinder from which it has been removed.

The plugs should now be carefully examined and, for guidance, compared with a new plug.

Oil fouling will be indicated by a wet shiny black deposit on the insulator. This condition is usually caused by worn cylinders, pistons or gummed rings. Oil vapour which is forced from the crankcase

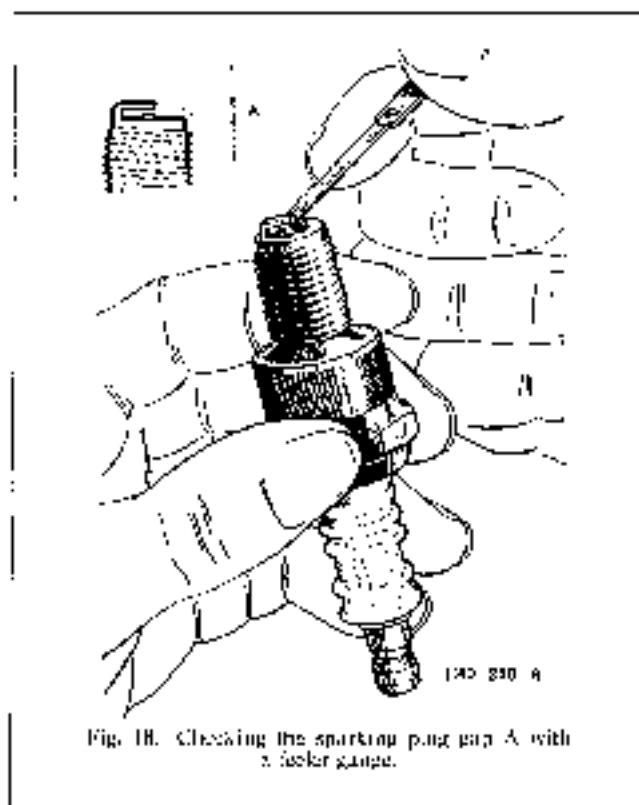

Fig. 10. Checking the sparking plug gap A with a feeler gauge.

during the suction stroke of the piston, fouls the plugs.

Petrol fouling will cause a dry fluffy black deposit to be apparent on the plugs. This is usually caused by faulty carburation or ignition system. In this latter connection the distributor coil or leaking and worn and ignition leads may be contributory causes.

Under the above conditions, if the plugs otherwise appear to be sound, they should be thoroughly cleaned, adjusted and tested.

When preparing for cleaning, the plug washers should be removed and examined. The condition of these washers is important, so that a large proportion of the heat from the plug insulator is dissipated to the cylinder head by them. The washer should therefore be reasonably compressed. A loose plug can be easily overheated, thus upsetting its heat range and causing pre-ignition, with consequent short plug life. On the other hand, do not overtighten. All that is needed is a good seal between the cylinder head and the plug. Tightening too much will cause distortion of the washers, with the possibility of blow-by which will again lead to overheating and resulting dangers. If there is any question of defect, replace with new washers.

The plugs should now be thoroughly cleaned of all carbon deposit, resorting to scraping if necessary, removing as much as possible from the space between the insulator and shell. An oily plug should be washed out with petrol. If a plug cleaning machine is available, 5 to 10 seconds in this will remove all remaining

signs of carbon. Remember to thoroughly "blow-out" the plug after treatment under these conditions, in order to remove all traces of adhesive left inside.

After cleaning, thoroughly examine the plug for cracked insulator or worn away insulator nose. Should either of these conditions be apparent a new plug should be installed.

Carbon deposit on the threads of the plug should be carefully removed by using a wire brush, or, if available, a wire buffing wheel. Take care not to damage the electrodes or insulator tip. Omission of this cleaning operation will lead to tight threads and the resultant loss of heat dissipation due to the carbon deposit, and thereby causing overheating.

The condition of the electrodes should now be noted and (if it is felt that the plugs are worthy of further use) any signs of corrosion removed. This can be carried out with the use of a small file, to carefully dress the gap area. The gap should then be reset, using the plug gauge provided in the tool kit. When resetting, bend the side electrodes only, never bend the central one as this may split the insulator tip.

If a plug testing machine is available, the plugs can be accurately tested to ascertain their fitness for

further service in the car. The plugs should be set to the correct gap before being subjected to this test.

A plug can be considered fit for further use if it gives a continuous spark, when in the testing machine, up to 100 lbs. per square inch. Having been found satisfactory refit in the engine.

It is advisable, whilst the plugs are under pressure in the testing machine, to apply a spot of oil to the terminal end, to check for air leakage. Excessive leakage here will tend to cause compression loss, rapid deterioration of the electrode and overheating of the electrode tip. The top half of the insulator should be carefully examined for any signs of paint splashes or accumulations of grime and dust, which should be removed. Should there be any signs of cracks due to faulty use of the spanner, the plug should be replaced.

It is recommended that plugs should normally be replaced every 10,000 miles (16,000 km.). When replacing the plug lead, make sure that it is securely attached.

Make plug inspection, cleaning and testing a routine job and carry this out at least every 3,000 miles (4,800 km.). Remember, plugs in good condition will ensure better fuel consumption and good engine performance.

## REMOVING AND REFITTING THE ENGINE

### Saloon, Coupé

Drain the water from the system and then disconnect the battery terminals. The engine may be drained of oil, but this is not essential.

The first operation is to remove the bonnet. To do this, release two belts, nuts and washers from each hinge, then lift off the bonnet.

Release the upper water hose from the radiator header tank, and the thermostat housing. To effect this removal, slacken the hose clip screws at either end of the hose with the end of a screwdriver and then ease the rubber pipe off both the radiator and thermostat housing connections. In a similar manner release the lower hose from the water pump. The temperature gauge half should now be removed from the radiator.

Next release the three securing bolts at each side of the radiator (see Fig. 8, page B/5), with nuts and washers, that hold the radiator to its mounting frame. The radiator may now be lifted from the car.

For the removal of the cooling fan, simply extract the four setpins that secure the fan to the water pump pulley.

At the left-hand side of the engine, take off the air cleaner after slackening the clamp at the carburettor intake and releasing the breather pipe from the valve

rucker cover. From the carburettor throttle, disconnect the operating rod by removing the securing nut and washer of the ball joint connector pin and pull the pin clear of the throttle lever. Release the choke control

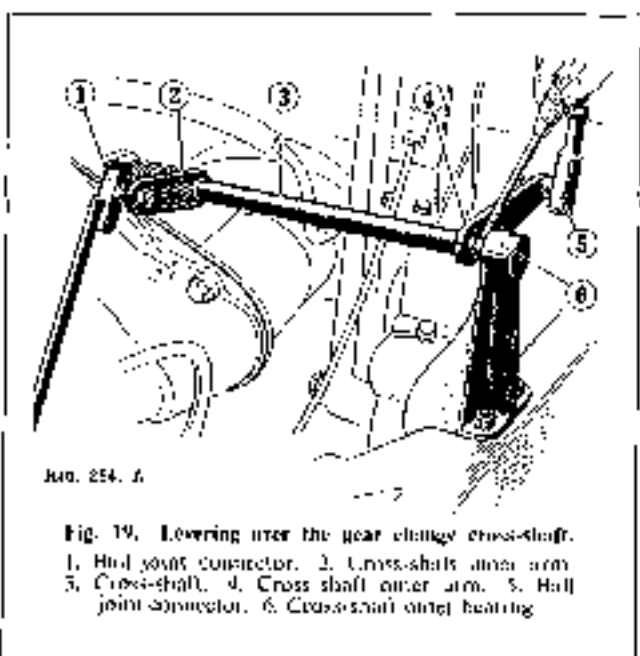
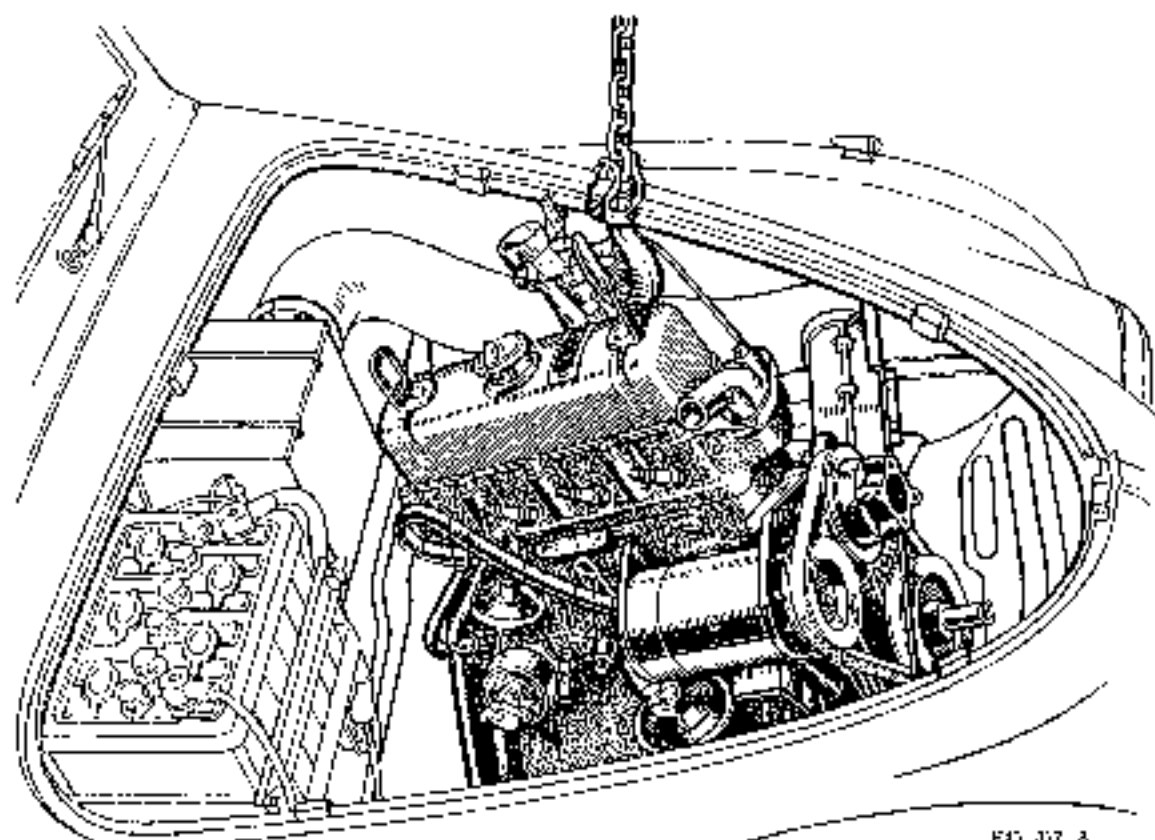

Fig. 19. Lowering over the gear change cross-shaft.  
1. Ball joint connector. 2. Cross-shaft inner arm  
3. Cross-shaft. 4. Cross-shaft outer arm. 5. Ball joint connector. 6. Cross-shaft outer bearing



E45, 317, A

Fig. 20. Illustrating the position of the engine before it is turned diagonally across the engine compartment and maneuvered clear of the car.

come from the carburettor by slackening the screws at the choke operating arm and withdrawing the cable.

Disconnect the fuel pump flexible pipe at the pump union nut.

Next release the heater cut off pipe from the rear of the engine, secured by a spring clip.

Release the exhaust down pipe from the exhaust manifold flange, by removing the three nuts and washers from beneath the pipe flange. Free the down pipe from the manifold studs.

Now working from the right-hand side of the engine remove the heater delivery hose at the side of the engine by slackening its spring clip. Release the dynamo terminals held in position by two nuts.

Remove the distributor cap with its coil and plug leads, and then lift off the rotor arm. Withdraw the two setpins that pass through the coil bracket to the engine mounting bracket extension. Remove the coil. *Note.*—On later models the coil is mounted on top of the dynamo and need not be removed.

Remove the oil pressure gauge flexible pipe by releasing the unions at each end.

The gear change cross-shaft (see Fig. 19), must first be freed from the gear change mechanism by disconnecting the upper ball joint connector of the link rod. Then disconnect the second ball joint connector, at the cross-shaft, of the link rod between the cross-shaft and the gearbox movement. Using a small pinch bar inserted between the cross-shaft outer bearing bracket and the first cross-shaft arm, lever the shaft towards the engine until it springs clear of the outer bearing. Pull the cross-shaft clear of the bracket on the engine, taking care not to lose the spherical bronze bush and spring from the end of the shaft. Remove the cross-shaft bracket which is held by two of the engine to gearbox setpins.

The cable from the starter switch to starter must be disconnected at the fore-end of the starter.

Operating from above, remove the top four nuts and bolts that secure the gearbox to the engine backplate. This will release the battery earthing cable and top bolt of the starter flange.

If there is no pit available, the front of the car should be raised by a jack. The four remaining engine to gearbox bolts, nuts and washers should now be removed. This will release the crankcase breather pipe

and the bottom bolt of the starter flange. Also uncouple the spring connecting the clutch operating lever to the engine backplate. The car should now be lowered to the ground and the gearbox supported beneath the bell-housing, in a convenient manner, to keep it in its natural position. Withdraw the four screws from each engine front mounting bracket and chassis side member.

Now attach a suitable sling to the two engine lifting brackets, situated on top of the valve rocker cover. Raise the engine very slightly, and at the same time pull it forward as far as it will go; this will partially free the flywheel from the first motion shaft.

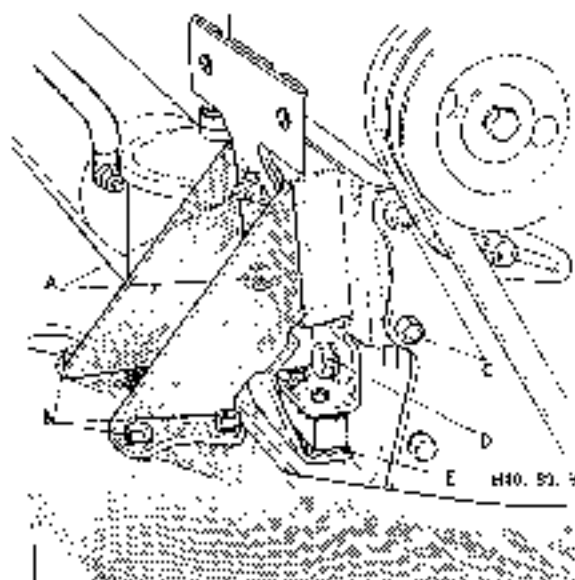

Fig. 21. Showing the engine front mounting. A. Bolts to mounting brackets. B. Bolts to chassis frame. C. Bolts to engine front mounting plate. D. Bolt to crankcase. E. Clearance to be a minimum of  $\frac{1}{8}$ -in. and maximum of  $\frac{1}{4}$ -in.

Uncouple the sling and attach it to the front bracket only (Fig. 20). Remove the front mounting brackets from the engine, then raise the engine and gearbox simultaneously until the top of the gearbox is up against the scuttle. Tilt the engine a little and pull it forward until the flywheel is completely off the first motion shaft. Swing the engine round so that it lies diagonally across the engine compartment, carburettor side forward, and then manœuvre it out of the car.

Refitting the engine is a reversal of the above procedure which should present no difficulty. If the clutch has been dismantled, remember to centralise the clutch driven plate as described in Section E, page 5.

#### Sports

The removal operations for the Sports engine, minus the gearbox, are the same as those for the Saloon, except for the following.

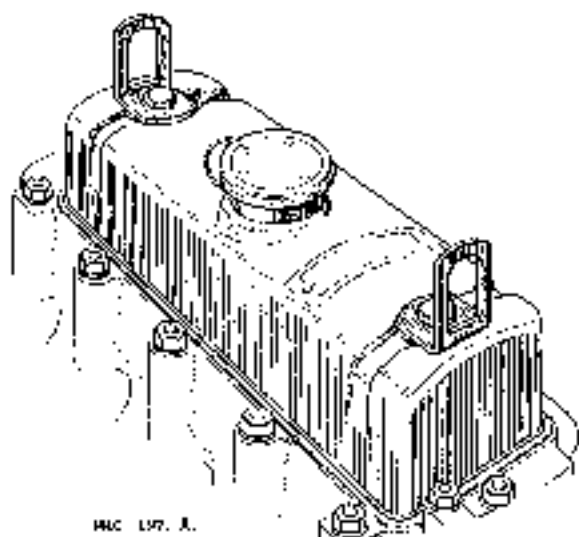

Fig. 22. Illustrating the lifting brackets on top of the valve rocker cover.

The engine oil should be drained off and the oil sump removed. This avoids possible damage by contact with the chassis front cross member when the engine is being lifted out.

It is not essential that the gearbox be drained of oil.

Now remove the bonnet top by undoing the two bolts, with nuts and washers that secure the bonnet support to the upper half of the heater compartment. Take off the two nuts and washers from each bonnet hinge. The bonnet is now free to be lifted clear of the bodywork.

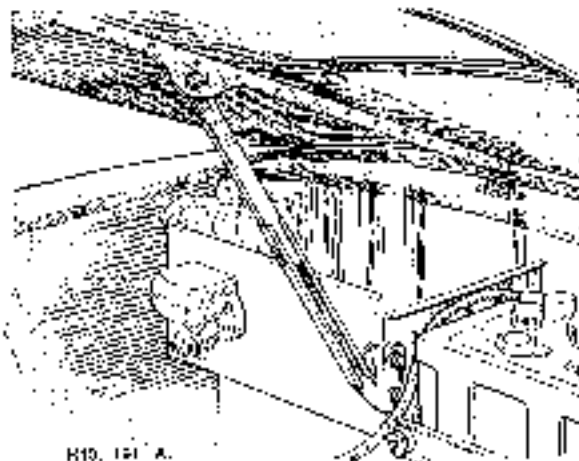

Fig. 23. Showing the securing points of the sports bonnet support.

Before removing the radiator, first drain the cooling system by means of the radiator and cylinder block drain taps. If anti-freeze solution is present, this may be collected in a clean receptacle and used again. Disconnect the top and bottom hoses. Remove the temperature gauge bulb from the radiator header tank and unfasten the bonnet lock control cable from its catch, situated just in front of the radiator tap.

Dismantle both horns from their brackets by undoing four nuts and bolts. Disconnect the leads from each horn, having first removed their covers. Break the snap connection on the left-hand side and then release the cable harness from the radiator mounting frame by undoing the three clips.

From under the wings, remove the top nut and bolt and the two setpins at each side which hold the radiator frame to the fitch plates. Withdraw, from beneath the car, the four setpins securing the radiator frame to the chassis front cross member.

With the fan blades turned horizontally, to save possible damage, the top of the radiator should be tilted towards the engine. The complete assembly can then be manoeuvred upwards and so clear of the car.

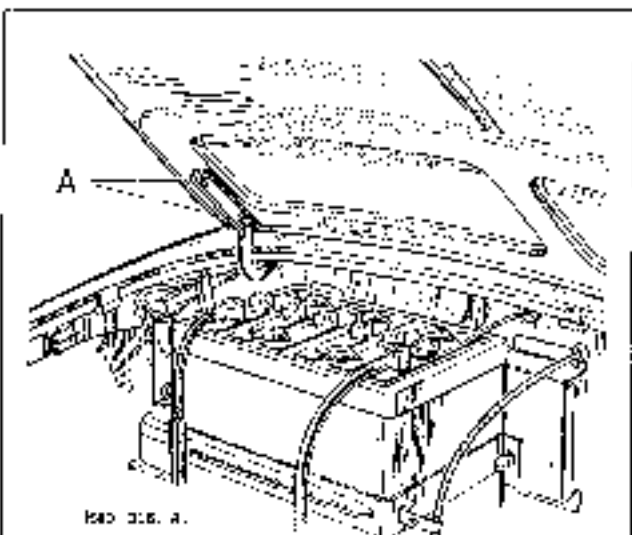

Fig. 24. Bonnet hinge securing points (A) of the Saloon and Coupe.

Working from above, uncouple the rubber connections of the heater pipes from the scuttle by slackening a clip at each connection. Next remove the carburettor air cleaners. To do this, release the cleaner to car-

burettor flange nuts and washers. From the carburettor disconnect the choke wire and the throttle control arm.

There is no need to remove the coil from its scuttle mounting.

#### Commercials

The engine removal operations for the Van Countryman and Pick-Up are similar to those of the Saloon and only the differences are dealt with here.

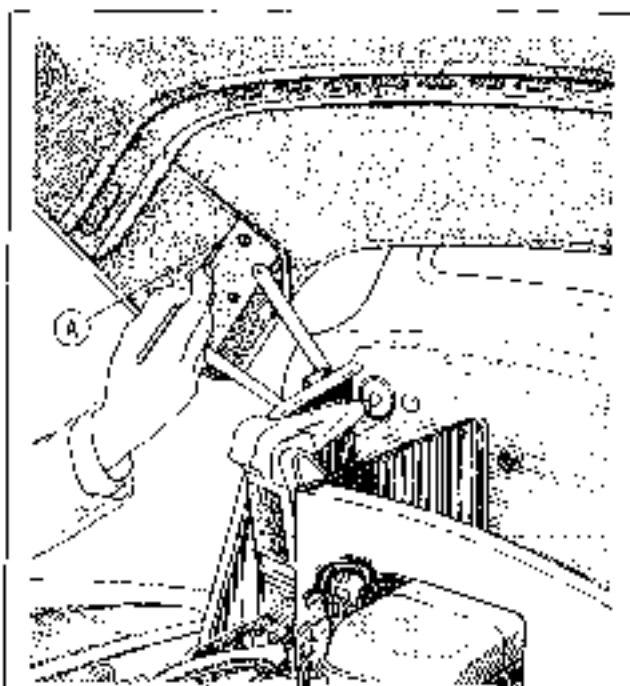

Fig. 25. Before removing bonnet on Commercial vehicles, scribe along the edge of each hinge as shown at A to facilitate replacement.

Remove the split pin from the fixed anchorage pin of the bonnet support, located by the side of the heater compartment. Before releasing the three bolts from each bonnet hinge, clearly scribe the bonnet along the edge of each hinge as this will help to ensure correct replacement. (See Fig. 25.)

The radiator should now be removed, but first drain the cooling system. Disconnect the upper and lower water hoses from the engine by slackening their spring clips. If a water temperature gauge is fitted, remove the temperature gauge bulb from the header tank. The radiator is held by six bolts, three either side, with nuts and washers. Remove these and lift out the radiator.

Remove the horns and the heater pipes as described for the Sports.



## OPERATIONS WITH THE ENGINE REMOVED

It is possible to perform a few of the following operations with the engine in position.

Before removal or replacement components must be cleaned but avoid the use of "fuffy" rags.

It should be understood that reassembly of the various parts is a reversal of the dismantling procedure unless otherwise stated.

### Removing the Tappets

Remove the valve rocker cover, slacken tappet adjustment and withdraw the push rods as described on page D/7.

Take off the two cylinder side covers, each held by one setpin and fibre washer. The cork cover joint if at all damaged must be replaced on reassembly. The rear cover carries the elbow for the crankcase breather pipe.

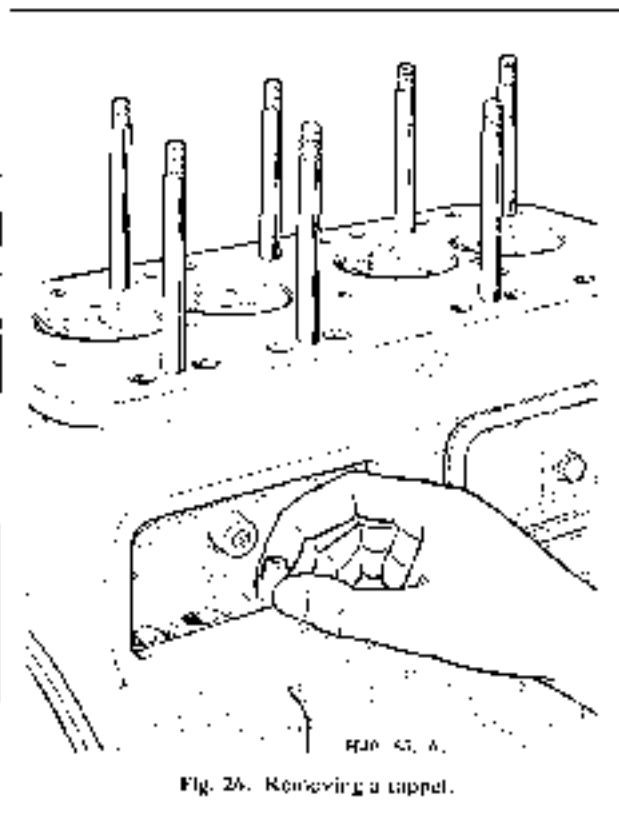

Fig. 26. Removing a tappet.

Withdraw the tappets from the crankcase (Fig. 26) and carefully examine the face in contact with the camshaft. Worn or damaged tappets should be replaced.

### Valve Timing Gear

For access to the valve timing gears or chain, first turn and remove the radiator (see Section B, page 5). Then remove the starting nut and belt pulley.

Using Service Tool 18G 98, see page Q/2, unscrew the starting nut on the crankshaft after knocking back the lockwasher. The spanner will probably have to be hammered in order to "start" this nut, but a few fairly sharp blows in an anti-clockwise direction should be sufficient.

Withdraw the keyed pulley from the crankshaft. Should the pulley prove tight, use extractor 18A12, illustrated on page Q/1.

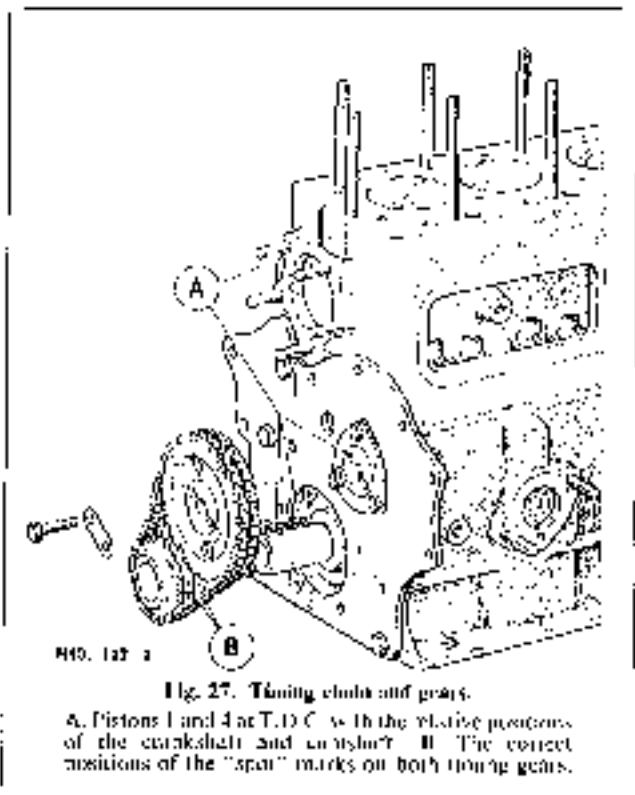

Fig. 27. Timing chain and gears.

A. Pistons 1 and 4 at T.D.C. with the relative positions of the crankshaft and camshaft. B. The correct positions of the "spot" marks on both timing gears.

### Timing Cover

The timing cover is held to the engine by nine setpins, three of which go to the engine front plate ( $\frac{1}{8}$  in.) (6.35 mm.), two to the main bearing cap ( $\frac{1}{8}$  in.) (6.35 mm.) and four to the crankcase ( $\frac{3}{16}$  in.) (7.9375 mm.).

Note. The two long  $\frac{1}{8}$  in. (6.35 mm.) setpins that secure the cover to the bearing cap must not be interchanged with the others.

There are special oval shaped washers and spring washers under each screw head.

After removing the cover and joint washer, take off the oil thrower (Fig. 32). To prevent oil seeping between the crankshaft and timing cover, the concave or hollow side of the thrower is fitted facing the pulley.

When reassembling do not damage the felt washer, make the joint carefully, using a new joint washer if necessary, and tighten the setpins evenly.

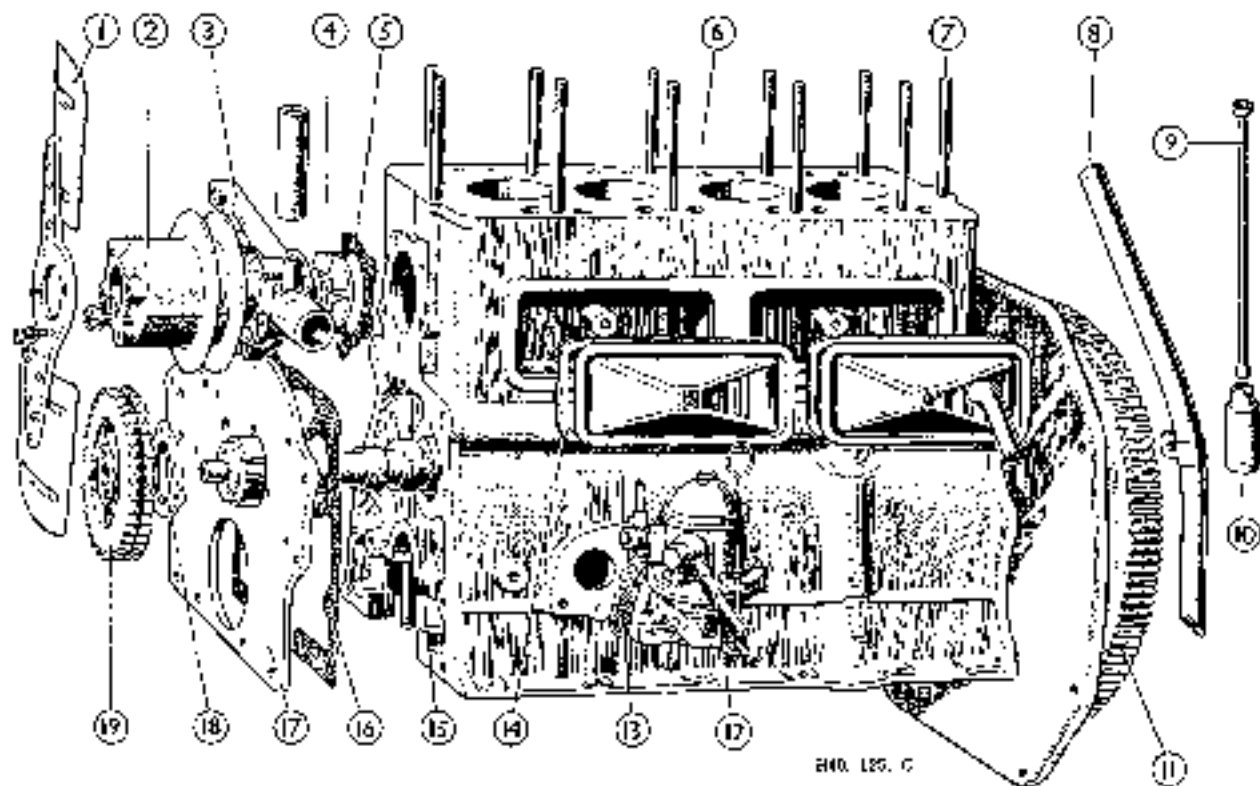

840. 125. C

Fig. 18. The cylinder and crankcase assembly

1. Fan
2. Fan pulley.
3. Water pump.
4. Water pump vane.
5. Joint washer.
6. Cylinder block.

7. Cylinder head stud.
8. Breather pipe
9. Push rod
10. Tappet.
11. Flywheel.
12. Fuel pump.

13. Joint washer.
14. Joint washer.
15. Camshaft.
16. Joint washer.
17. Engine front plate.
18. Camshaft locating plate
19. Camshaft gear.

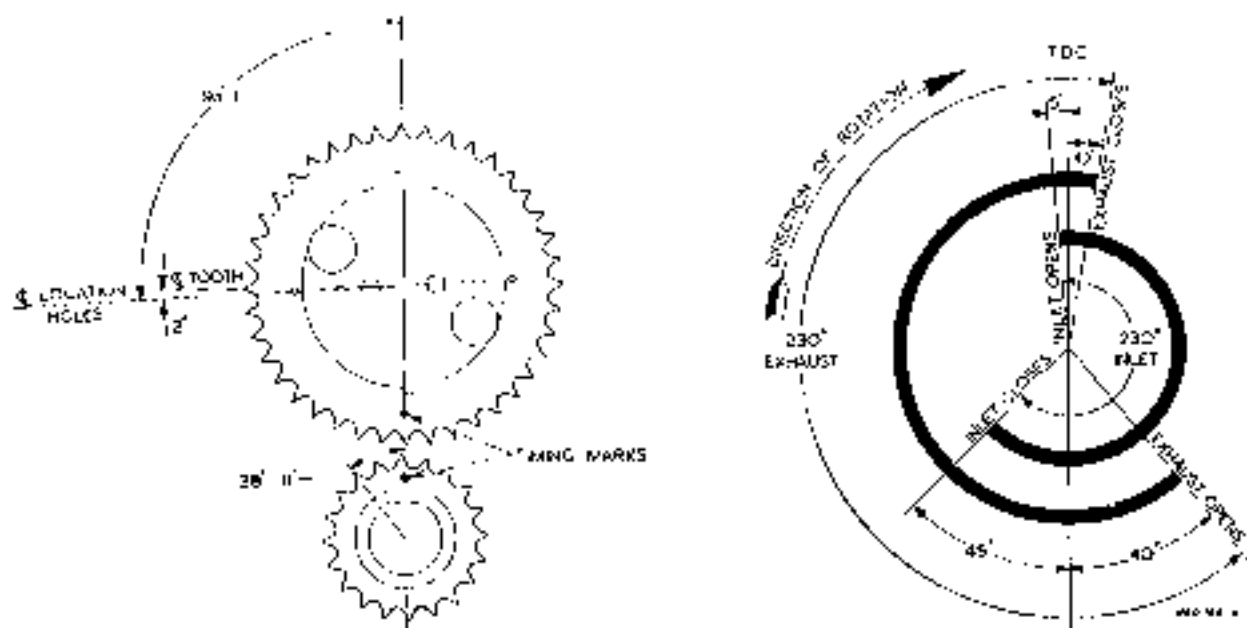

Fig. 29. Showing the technical diagram of the valve timing and the relative positions of the timing marks on the sprockets.

### Timing Chain and Gears

The removal of the timing chain and gears must be effected as one unit, there being no spring link incorporated in the chain. Turn back the ends of the camshaft gear lockwasher and remove the two setpins. The camshaft and crankshaft gears, together with the chain, can now be withdrawn.

To refit the timing gears to the camshaft and crankshaft, and to determine their correct relationship for valve timing, the gears and chain must be first assembled on the bench. The spot marks of the two gears must be in line and in their closest position.

Now turn the crankshaft until No. 1 piston is at T.D.C. and the camshaft positioned so that Nos. 7 and 8 valves are "rocking". This operation relates the two shafts in readiness to receive their respective gears.

Keeping the spot marks in line, push the smaller gear on to the keyed crankshaft a distance sufficient to enable the fitting of the larger gear to the camshaft then push both gears fully home and bolt the camshaft gear in position. Finally bend up the tabs of the locking washer.

### Withdrawing the Camshaft

The camshaft is positioned by a locating plate (18, Fig. 29), held by three setpins and shakeproof washers. Note the position of the small lubricating hole for the timing gear in this locating plate. When replacing, the

hole should be facing upwards towards the left-hand side of the engine. The camshaft end float of .002-.008-in (.0508 to .2032 mm.) should be checked by inserting a feeler gauge between the locating plate and the boss on the camshaft gear.

Before the camshaft can be withdrawn, the oil sump, oil strainer and oil pump will have to be removed (see page D/6), followed by the distributor spindle (see page D/13). Also remove the push rods and tappets. Carefully withdraw the camshaft so as not to damage the bearings.

Examine the cams and distributor drive for wear.

### Front Mounting Plate

The engine front mounting plate can now be removed by extracting the five remaining setpins from the crankcase and four bolts holding the engine mountings.

### Camshaft Bearings

These can only be renewed when the engine is out of the frame, as the engine backplate must be removed for access to the back bearing (see page D/20).

Old bearing liners can be punched out and new ones tugged into position. Oil holes must be carefully lined up and bearings reamed in line to give .001-.002-in. (.0254 to .0508 mm.) clearance on each.

### Oil Sump Removal (see page D/5).

### Removing the Flywheel

After taking off the Clutch (see Section E), the flywheel can be removed when the four nuts and the two locking washers have been released.

When replacing the flywheel, see that the 1,4 timing mark is in line with the first and fourth throws of the crankshaft.

### Engine Backplate

The engine backplate may be removed, after the flywheel, by taking out the remaining setscrews into the crankcase.

### Pistons and Connecting Rods

There is an oil jet in the top half of each big end bearing (see Fig. 30) and it is important that this should face *away* from the camshaft side of the engine. Ensure that this jet lines up with the hole in the shell bearing to give a free passage of oil.

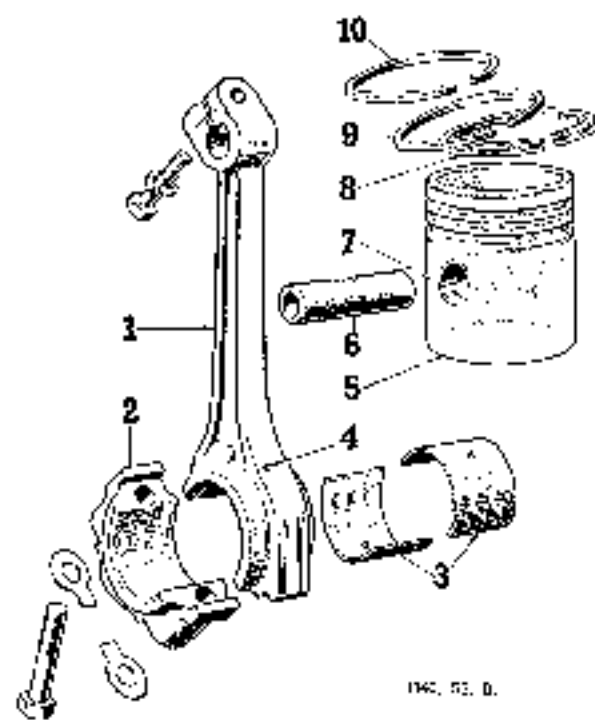

Fig. 30. Three-ring piston and connecting rod assembly.

- |                       |                           |
|-----------------------|---------------------------|
| 1. Connecting rod     | 6. Gudgeon pin            |
| 2. Connecting rod cap | 7. Oil hole               |
| 3. Bearings           | 8. Scraper ring           |
| 4. Oil hole           | 9. Lower compression ring |
| 5. Piston             | 10. Top compression ring  |

Remove the lockwashers and setpins from the big end and withdraw the cap. It will be noted that the bearing caps have their projections machined on them, which mate up with the recess on the big-end top half. The piston and connecting rod can now be pushed up through the bore, taking care not to damage the pistons or rings.

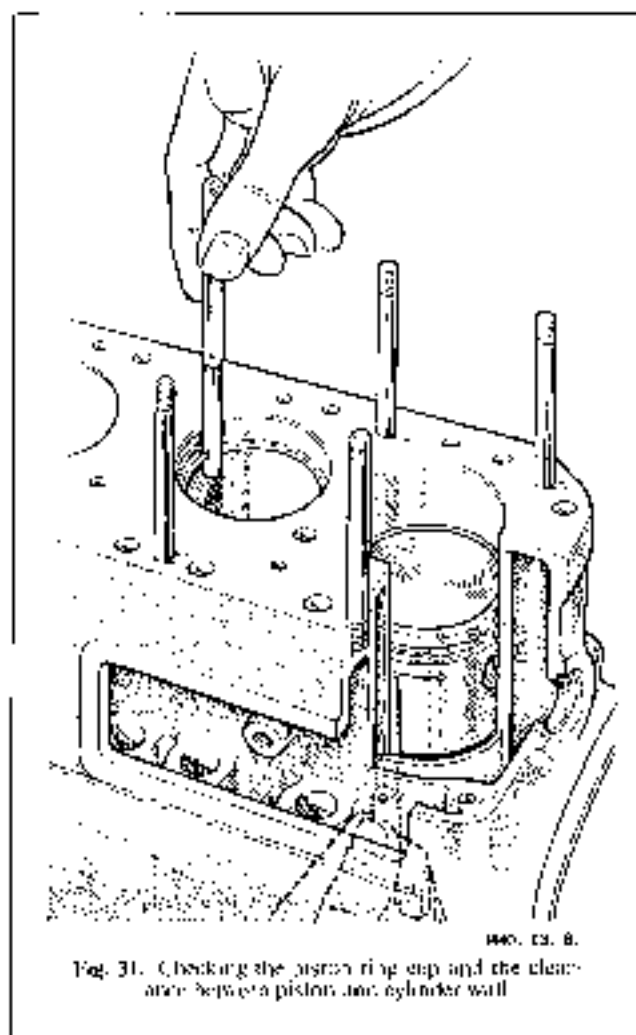

Fig. 31. Checking the piston ring gap and the clearance between a piston and cylinder wall

See page D/1 for the bearing sizes and fits. Check the crankshaft journals for out-of-round and scoring; either defect will entail the removal of the crankshaft for re-grinding.

From the front, the connecting rods are numbered 1 to 4, the numbers being stamped on both halves of the big-end bearing on the side facing the camshaft when they are assembled.

The shell bearings are removed by hand. New ones require no "bedding-in", it is sufficient merely to place them in position with the feathered ends located in the slots of both halves.

To withdraw the pistons and connecting rods take them upwards through the cylinder bores. Therefore, oil sump and cylinder head have to be removed.

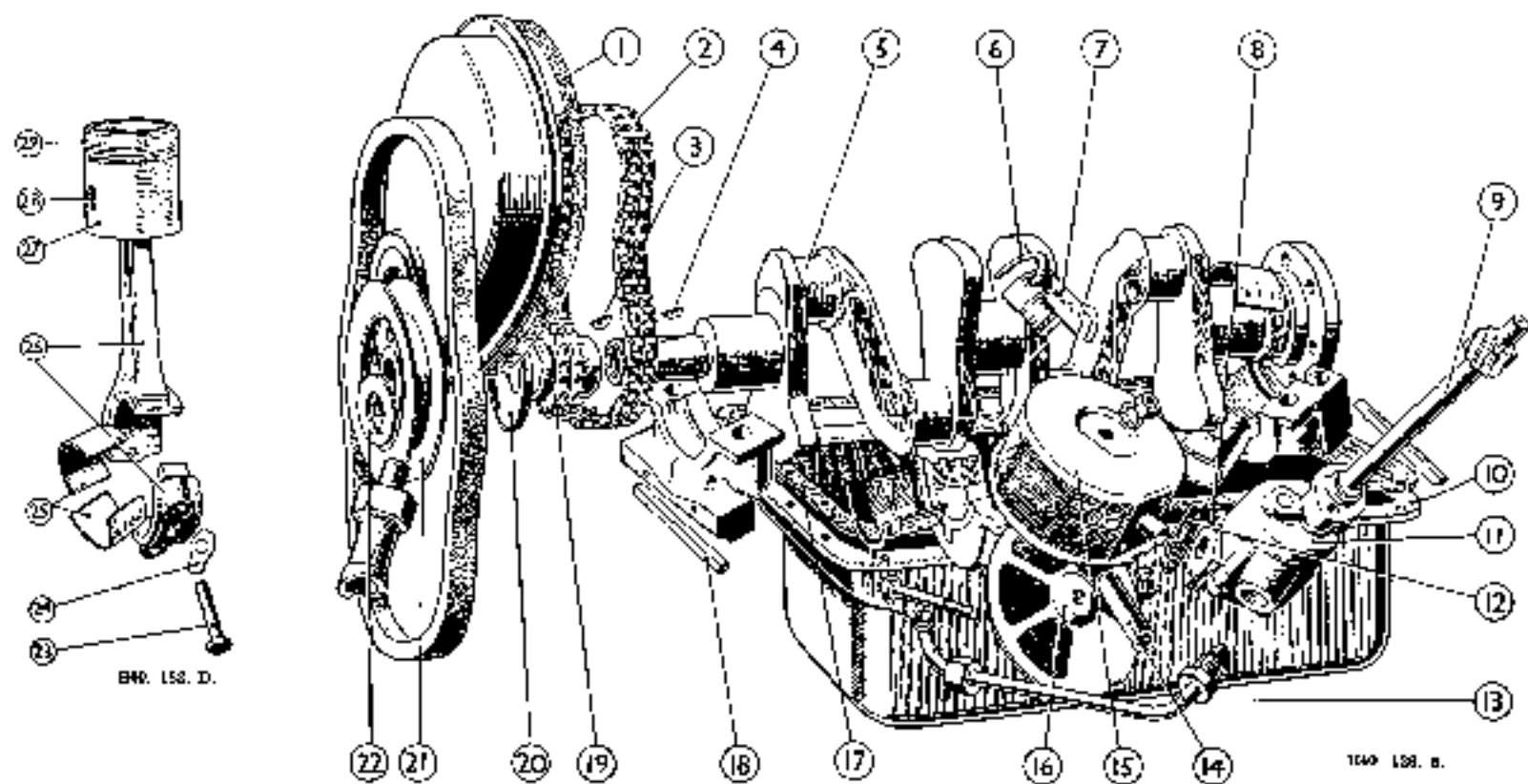
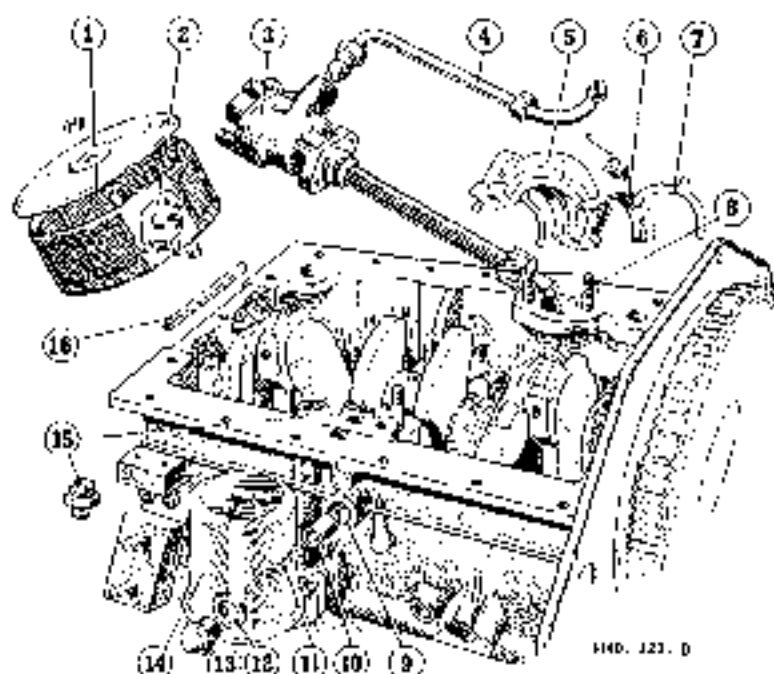

Fig. 32. Crankshaft and sump assembly.

- |                         |                         |                              |
|-------------------------|-------------------------|------------------------------|
| 1. Joint washer.        | 11. Oil pump body.      | 21. Crankshaft pulley.       |
| 2. Timing chain.        | 12. Joint washer.       | 22. Locking washer.          |
| 3. } Crankshaft keys    | 13. Oil delivery pipe.  | 23. Connecting rod bolt.     |
| 4. }                    | 14. Distance piece.     | 24. Tap washer.              |
| 5. Crankshaft.          | 15. Strainer body.      | 25. Connecting rod bearings. |
| 6. Thrust washer.       | 16. Strainer cover.     | 26. Connecting rod and cap.  |
| 7. Centre main bearing. | 17. Joint washer.       | 27. Piston.                  |
| 8. Oil strip flange.    | 18. Cork sealing strip. | 28. Crankpin.                |
| 9. Oil pump spindle.    | 19. Crankshaft gear.    | 29. Piston rings.            |
| 10. Oil surge.          | 20. Oil thrower.        |                              |

Fig. 33. An inverted view of the engine showing

1. Oil strainer.
2. Joint washer.
3. Oil pump.
4. Oil delivery pipe.
5. Centre main bearing cap.
6. Centre main bearing.
7. Thrust washer.
8. Oil pump housing.
9. Release valve housing.
10. Release valve.
11. Spring.
12. Washer.
13. Cap nut.
14. Oil filter.
15. Oil delivery pipe union.
16. Cork sealing strip.



140. 123. D

### Removing a Piston

Remove the clamping bolt in the small end of the connecting rod, push out the gudgeon pin and remove the piston.

### Pistons and Bores

There should be a clearance of .0012-in. (.0304 mm.) at the piston skirt and .0015-in. (.381 mm.) at the top

cylinder bore. Ensure that the rings are free in their respective grooves in the piston.

A piston ring guide will facilitate the replacement of the piston assembly (see Section Q/2).

### Oversize Piston Rings

After fitting oversize piston rings there may be a tendency to noisy operation due to cylinder bore "lip" which can be verified with a dial gauge. "Lip" should be eased by a hand-scraper.

### Removing the Crankshaft

The three main bearing caps are removed by withdrawing the split pins and releasing the nuts. The caps can then be lifted out with the aid of Service Tool 18G 42 and the crankshaft taken out.

After the main bearing cap nuts have been tightened, use new split pins and bend the ends back with pliers; hammering the ends back is not advised.

### Main Bearing Caps

The front and rear main bearing caps have cork oil sealing strips fitted into a recess (see Fig. 33). In rebuilding see that these strips are in place and in good condition.

The centre main bearing requires special attention as it has split thrust washers at each side. See that the

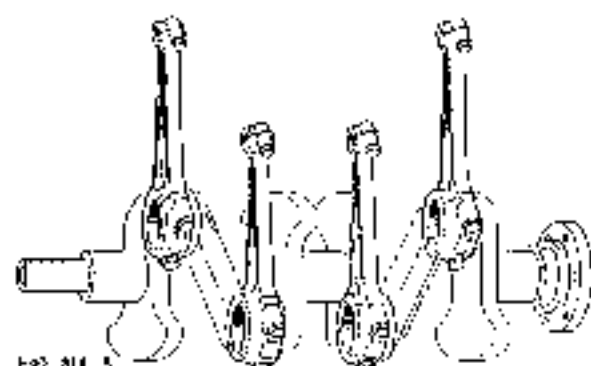

Fig. 34. Order of assembly of the connecting rods. Note the relative positions of the big end of pins.

load, measurement being taken at right angles to the gudgeon pin and in the working part of the cylinder bore. (See Fig. 31.) Piston ring gap should be .003-in. to .012-in. (.0762 to .3048 mm.) when tested in the

peg formed on each pair fits into the bearing cap, Fig. 33, on replacement.

New shell bearings, whether standard or undersize, should be fitted with their feathered projection correctly located.

Handle the new shell bearing halves carefully as they have a very fine finish, and ensure that all dirt and

grit is removed from the bearing cups and journal faces. Also check that the journal oil ways are free from foreign matter.

When fitting bearings ensure that all bearing caps are replaced the right-way round—the stamp markings on each cap should face the crankshaft side of the engine.

---

## DIAGNOSIS AND CORRECTION OF FAULTS

Fault and Possible Cause	Rectification
<b>Lack of Power</b>	
Low or poor compression .. .. .	Decarburise and regrind valves.
Defective or retarded ignition .. .. .	Check ignition system.
Incorrect valve clearance .. .. .	Reset clearance on each valve to .015-in. (.381 mm.).
Choked jets .. .. .	Remove and clear of foreign matter
Overheating .. .. .	Check cooling system.
Incorrect grade of oil .. .. .	Drain and refill with correct grade.
Leaking joint washers .. .. .	Carefully check and replace as necessary.
<b>High Fuel Consumption</b>	
Retarded ignition .. .. .	Check ignition system.
Air cleaner to carburettor dirty .. .. .	Clean as described in "Fuel System."
Sticking valves .. .. .	Clean valve guides and polish valve stems.
Faulty sparking plugs .. .. .	Clean and check gap. Replace if necessary.
Petrol leaks in general .. .. .	Check all joints and connections.
Carburettor incorrectly set .. .. .	Reset as specified.
<b>Low Compression</b>	
Leaking valves .. .. .	Reface and "grind in."
Badly fitting piston rings .. .. .	Refit with correct clearances.
Broken piston rings .. .. .	Renew the piston rings.
Valve springs weak or broken .. .. .	Renew springs as necessary.
Piston ring grooves worn .. .. .	Fit new piston.
Scored or worn cylinder bores .. .. .	Recore cylinder and fit new pistons and rings.
Valve stems or guides worn .. .. .	Replace worn parts.
Valve timing incorrectly set .. .. .	Reset as specified.
<b>Burned Valves or Seats</b>	
Valve spring weak or broken .. .. .	Renew springs as necessary.
Sticking valves .. .. .	Clean valve guides and polish valve stems.
Incorrect valve timing .. .. .	Reset as specified.
Excessive carbon around valve seat or head .. .. .	Clean away carbon and reface valves.
Incorrect valve clearance .. .. .	Reset clearance on each valve to .015-in. (.381 mm.).
Sticking tappet .. .. .	Ease or replace as necessary.
Overheating .. .. .	Check cooling system.
Rocker arm stuck .. .. .	Free the rocker arm or replace.
<b>Sticking Valves</b>	
Bent valve .. .. .	Replace the valve.
Scored valve stem .. .. .	Polish stem and clean the stem or replace.
Incorrect clearance between valve and guide .. .. .	Check clearance and refit.
Incorrect valve clearance .. .. .	Reset clearance on each valve to .015-in. (.381 mm.).
Valve spring weak or broken .. .. .	Renew springs as necessary.
Tappets sticking .. .. .	Check clearances.



## Fault and Possible Cause

## Rectification

**Excessive Cylinder wear**

Incorrect grade of oil	...	...	...	...
Lack of oil	...	...	...	...
Dirty oil	...	...	...	...
Overheating	...	...	...	...
Air cleaner dirty (dust entering combustion chamber)	...	...	...	...
Fuel mixture setting too rich	...	...	...	...
Piston rings stuck in grooves or broken	...	...	...	...
Badly fitted pistons	...	...	...	...

Use recommended grades.  
 Maintain correct oil level.  
 Change oil, using correct grade.  
 Check over cooling system.

Clean, and if oil bath type, maintain correct oil level.  
 Reset carburetter.  
 Replace and refit piston rings.  
 Refit to clearances specified.

**Excessive Oil Consumption**

Piston rings badly fitted	...	...	...	...
Piston rings stuck or broken	...	...	...	...
Oil return holes in piston choked with carbon	...	...	...	...
Excessive cylinder wear	...	...	...	...
Cylinder scored	...	...	...	...
Oil level too high	...	...	...	...
Oil leaks from washers	...	...	...	...

Replace and refit piston rings.  
 Replace and refit piston rings.  
 Remove carbon from groove and oil holes.  
 Rehone and fit new pistons and rings.  
 Rehone and fit new pistons and rings.  
 Maintain correct oil level.  
 Check carefully all joints concerned.

**Crankshaft and Connecting Rod Bearing Failure**

Crankshaft oil ways restricted	...	...	...	...
Crankshaft journals worn	...	...	...	...
Crankshaft bearings loose	...	...	...	...
Lack of oil	...	...	...	...
Incorrect grades of oil	...	...	...	...
Low oil pressure	...	...	...	...
Connecting rod bent	...	...	...	...
Connecting rod bearings loose	...	...	...	...

Thoroughly clear all oil ways  
 Regrind or replace.  
 Tighten up as necessary  
 Maintain correct oil level.  
 Drain and refill with correct grade  
 Check filters and oil pump.  
 Re-align or replace.  
 Tighten up as necessary.

**Overheating**

Cooling system defective	...	...	...	...
Thermostat not working	...	...	...	...
Dirty air cleaner	...	...	...	...
Incorrect valve timing (too early)	...	...	...	...
Fuel mixture setting too weak	...	...	...	...
Incorrect grade of oil	...	...	...	...
Defective or retarded ignition	...	...	...	...

Check cooling system over carefully.  
 Replace if damaged.  
 Clean, and if oil bath type, maintain.  
 Reset as specified  
 Reset carburetter.  
 Drain and refill with correct grade of oil  
 Check ignition system.

**Intermittent running and "Popping back"**

Defective ignition	...	...	...	...
Spark plugs in bad condition	...	...	...	...
Incorrect carburetter adjustment	...	...	...	...
Valve timing set too early	...	...	...	...
Weak valve springs	...	...	...	...
Valves not correctly seated	...	...	...	...
Valve adjustment too closely set	...	...	...	...

Carefully check ignition system settings.  
 Clean and set gaps. Replace if necessary  
 Reset carburetter, as specified.  
 Reset valve timing, as specified.  
 Replace valve springs.  
 Regrind valves.  
 Reset valve clearance to .015-in. (.381 mm.)







# CLUTCH

## GENERAL DATA

Make	Borg and Beck
Type	Single Dry Plate - Spring Drive
Outside Diameter	7 $\frac{1}{2}$ -in. (18.4 cm.)
Total Frictional Area	20.03 x 2 sq. in. (128.2 x 2 cm <sup>2</sup> )
Thrust Bearing Type	Carbon
Number of Springs	6

Total Axial Spring Pressure	780-840 lbs. (354-381 kg.)
Distance, Thrust Race to Thrust Plate	$\frac{1}{2}$ - $\frac{3}{4}$ in. (2.38-3.17 mm.)
Thrust Plate Travel to Fully Released Position	.12-.17 in. (.81-.93 mm.)
Pedal Clearance (free movement)	$\frac{1}{2}$ -in. (19.05 mm.)

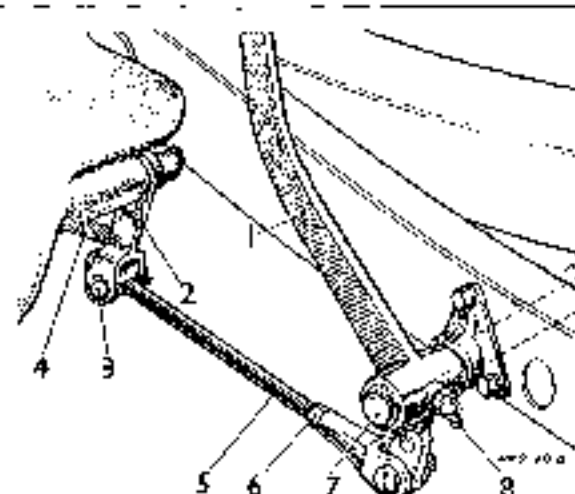

Fig. 1. The clutch pedal assembly, right-hand.

- |                               |                           |
|-------------------------------|---------------------------|
| 1. Clutch shaft               | 5. Clutch adjusting rod.  |
| 2. Shaft oil nipple.          | 6. Lock nut               |
| 3. Transmission pin fit lever | 7. Pedal bracket spindle. |
| 4. Return spring              | 8. Spindle oil nipple.    |

### Running Adjustments

The only necessary adjustment is to restore the free movement of the clutch pedal (i.e. movement of the pedal before the release bearing comes into contact with the release lever plate and commences to withdraw the clutch). As the driven plate linings wear, the free movement of the pedal will gradually decrease, thus tending to prevent the clutch fully engaging and permitting too great a movement on withdrawal. This free movement must be maintained at the correct amount, which is approximately  $\frac{1}{2}$  in. (19.05 mm.).

Adjustment is made by altering the effective length of the rod between pedal and clutch operating lever on the clutch shaft end (see Figs. 1 and 4). To increase the movement first slacken the locknut and screw out the adjusting rod by means of its hexagon head. Finally tighten the locknut.

In all cases adjustment must be such as to allow this free movement to be felt by the pressure of one finger on the clutch pedal.

To ascertain the amount of free movement, depress the pedal until the resistance of the clutch springs is felt.

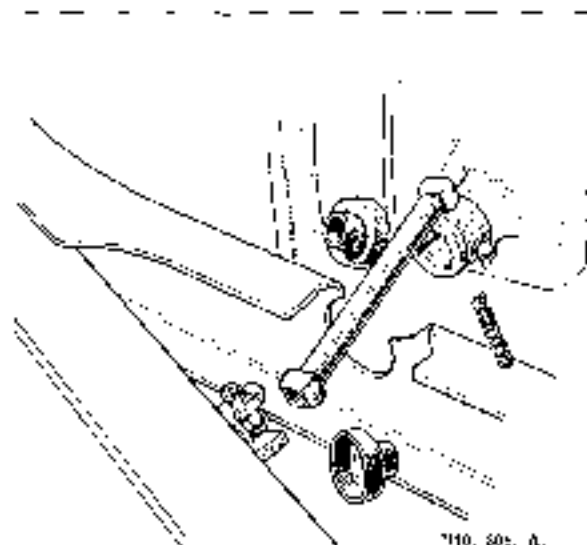

Fig. 2. The universal drive assembly between the clutch pedal linkage (A-B-C) and the dumb-bell operating shaft shown in exploded form.

### Driven Plate Assembly

This is of the flexible centre type (5) in which the splined hub is indirectly attached to a disc (see Fig. 3), which transmits the power and over-run through a number of coil springs held in position by retaining wires. Two friction linings are riveted to the disc.

### Cover Assembly

The cover assembly consists of a pressed steel cover (2) and a cast iron pressure plate (4) loaded by six thrust springs (12). Mounted on the pressure plate are three release levers (9) which pivot on floating pins (11) retained by eye bolts (10). Adjustment nuts (13) are screwed on to the eye bolts and secured by staking. Struts (6) are interposed between the lugs on the pressure plate and the outer ends of the release levers. Anti rattle springs (8) load the release levers and retainer springs (17) connect the release lever plate.

### Release Bearing

The graphite release bearing, shrunk into a cup (1) is located by a fork (15), and springs (14).

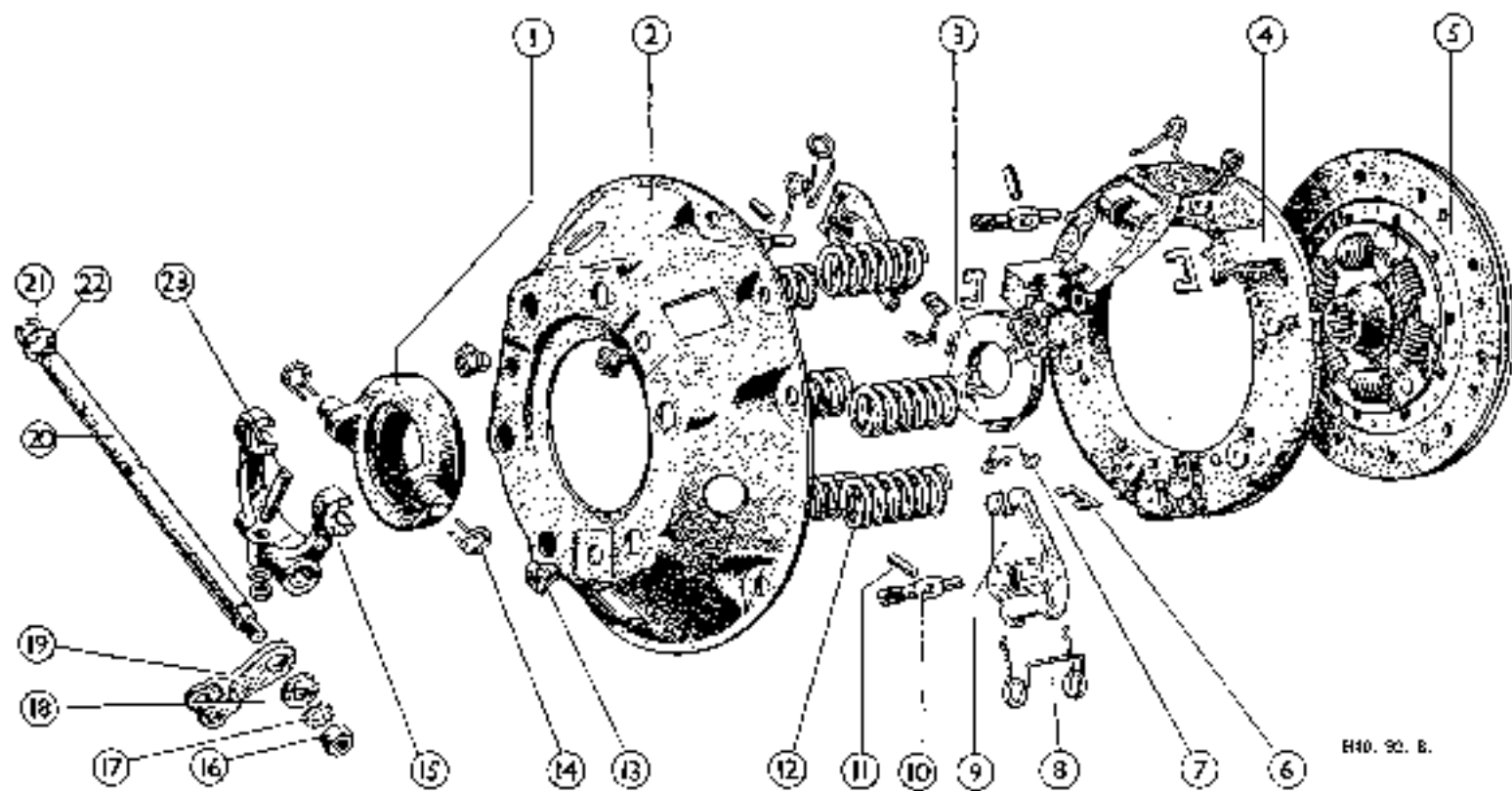

H40. 90. B.

Fig. 3. An exploded view of the clutch.

- 1. Release bearing and cup
- 2. Clutch cover
- 3. Release lever plate
- 4. Pressure plate assembly
- 5. Clutch plate with fringes
- 6. Strut for release lever
- 7. Retainer spring
- 8. Anti-rattle spring

- 9. Release lever
- 10. Eye bolt
- 11. Release lever pin
- 12. Thrust spring
- 13. Nut for eye bolt
- 14. Release bearing retaining spring
- 15. Withdrawal fork
- 16. Shaft nut

- 17. Shockproof washer
- 18. Clutch shaft washer
- 19. Shift lever
- 20. Clutch operating shaft
- 21. Shaft
- 22. Washer
- 23. Withdrawal fork collar

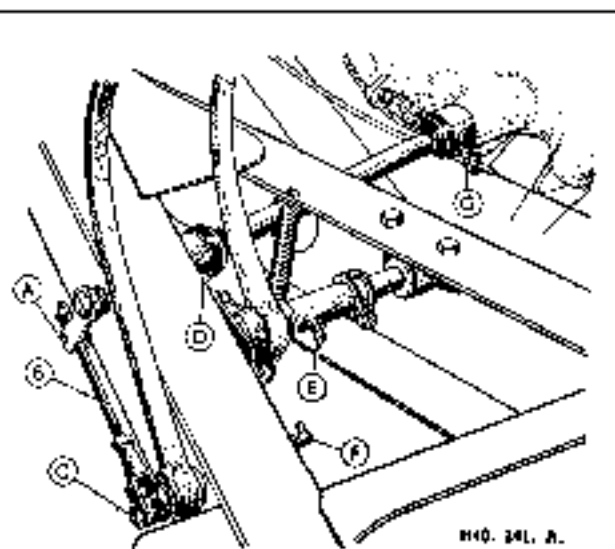

Fig. 4. The clutch pedal assembly, left-hand.

A. Spring loaded link. B. Adjustment rod. C. Adjustment fork. D. and G. Dumb-bell universal joint lubricators. E. Brake pedal shaft lubricator. F. Clutch pedal shaft lubricator.

The  $\frac{3}{8}$ -in. (9.525 mm.) of free movement in the pedal will give a minimum clearance of  $\frac{1}{4}$ - $\frac{1}{2}$ -in. (2.38-5.17 mm.) between the graphite release bearing and the release lever plate, thus preventing continual rubbing of the release bearing on the plate.

For left-hand models the pedal is separate from the actual operating linkage although adjustment is carried out as described for the right-hand mechanism. The pedal is anchored to its individual shaft by a cone type cotter and nut, whilst its shaft, which passes through two zinc bushes housed in a bearing tube through the chassis side member, is secured on the inside of the chassis by a e-clip. One lubricating nipple is provided on the inner end of the shaft.

A clutch adjusting rod takes the movement forward to the spring loaded link arm which fits over the flats of

the short shaft passing through the chassis side member. A nut finally secures the arm to its shaft. The shaft and bearing tube is identical in design to the pedal shaft inasmuch that it has two zinc bushes, but on the inside face the tube has a female squared universal joint incorporating internally a thrust cone. One lubricating nipple is screwed into this joint.

A similar joint is welded to the clutch operating shaft of the bell housing, but instead of the internal cone it has a recess to take a coil spring. Then between the clutch shaft and the linkage joint there is a dumb-bell bar, the male squares of which (at each end) locate into each universal joint, when the spring will keep the thrust against the cone of the linkage joint.

To dismantle the mechanism, the dumb-bell is pushed inwards against the tension of the operating shaft spring when the other end will be free of the linkage. Pull the dumb-bell rearward clear of the operating shaft.

To dismantle the linkage the outer nut must be removed, the link arm withdrawn from its locating fluts, followed by the removal of the spring when the shaft will be easily extracted from the inside of the chassis side member. Thus renewal of zinc bushes can be readily accomplished, theirs being a press fit in the bearing tube.

### Removing the Clutch

To gain access to the clutch it is first necessary to remove the complete gearbox from the engine (see Section F.1). Before the gearbox is dismantled from the engine, support the engine at its after end by packing up with suitable wooden blocks or a jack.

Once the gearbox is free, slacken the clutch cover securing screws a turn at a time by diagonal selection until the spring pressure is relieved. Then remove the screws completely and lift the clutch assembly away from the flywheel. Finally remove the driven plate assembly. Note: The clutch release lever adjustments are correctly

Fig. 5. Parts of clutch assembly tool.

- A. Centre pillar.
- B. Height finger.
- C. Adjusting mechanism.
- D. Sclips.
- E. Speed brace.
- 1. } Spring washers.
- 2. }
- 3. }
- 4. }
- 5. }
- 6. } Distance pieces.
- 7. }
- 8. }

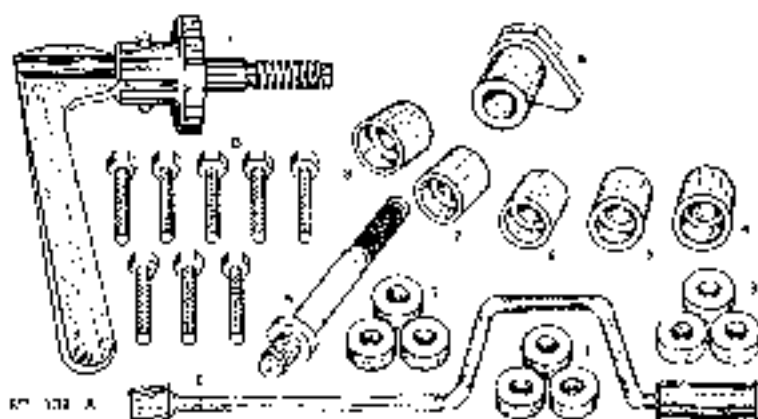

set and locked when the clutch is assembled and should not be altered unless the clutch has been dismantled and new parts fitted. Interference with adjustment will throw the pressure plate out of position and cause the clutch to judder.

#### Dismantling, Assembling and Gauging the Clutch

By using the clutch tool, a clutch can be quickly dismantled, reassembled and adjusted to a high degree of accuracy.

The tool comprises of the following parts: a base plate, centre pillar, spacing washers, distance pieces, height finger, actuating mechanism, set screws, speed brace and metal box. As this tool is universal a chart indicating the particular parts to be used for the various sizes of clutch will be found in the inside of the lid of the metal box.

#### Method of Operation

##### Dismantling

With a 73-in. (1841.5 cm.) clutch, select three spacing washers (2) and place them over the code letter (B) on the base plate. (See Fig. 4.)

Now place the clutch on to the three spacing

washers so that the holes in the cover coincide with the tapped holes in the plate, insert the set screws provided, and tighten them, a little at a time, by diagonal selection until the cover is firmly attached to the base plate at all possible points. This is most important if the best results are to be achieved.

Mark the cover, pressure plate lugs and release levers with a centre punch so that the parts can be reassembled in their relative positions in order to maintain the balance of the clutch.

Detach the release lever plate from the retaining springs and remove the three eye-bolt nuts or adjusting nuts.

Slowly release the pressure on the springs, unscrewing by diagonal selection the set screws securing the cover to the base plate. The clutch cover can then be lifted to expose all components for inspection.

The release levers, eye-bolts, struts and springs should be examined for wear and distortion. Renew these parts as necessary, bearing in mind that the thrust springs must only be renewed in sets.

Clean all parts and lubricate the bearing surfaces of the levers, eye-bolts, etc., sparingly with grease.

##### Assembling

Place the pressure plate over the three spacing washers on the base plate (9), with the thrust springs (7) in position on the pressure plate (6).

Assemble the release lever, eye-bolt and pin, holding the threaded end of the eye-bolt and the inner end of the lever as close together as possible. With the other hand, insert the strut in the slots on the pressure plate lug sufficiently to allow the plain end of the eye-bolt to be inserted into the hole in the pressure plate.

Move the strut upward into the slot in the pressure plate lug and over the ridge on the short end of the lever and drop it into the groove formed in the latter. Fit the other two levers in a similar manner.

Place the cover (4) over the assembled parts, ensuring that the anti-rattle springs are in position, and that the tops of the thrust springs (7) are directly under the seat in the cover. In addition the machined portions of the pressure plate lugs must be directly under the slots in the cover through which they have to pass.

Compress the pressure springs by screwing down the cover (4) to the base plate (9) by using the special set screws (5) placed through each hole in the cover. Tighten the screws, a little at a time, by diagonal selection to prevent distortion of the cover. The eye-bolts (11) and pressure plate lugs must be guided through the holes in the cover at the same time.

##### Gauging

Screw the nuts (10) on to the eye-bolts and proceed to adjust as follows:—

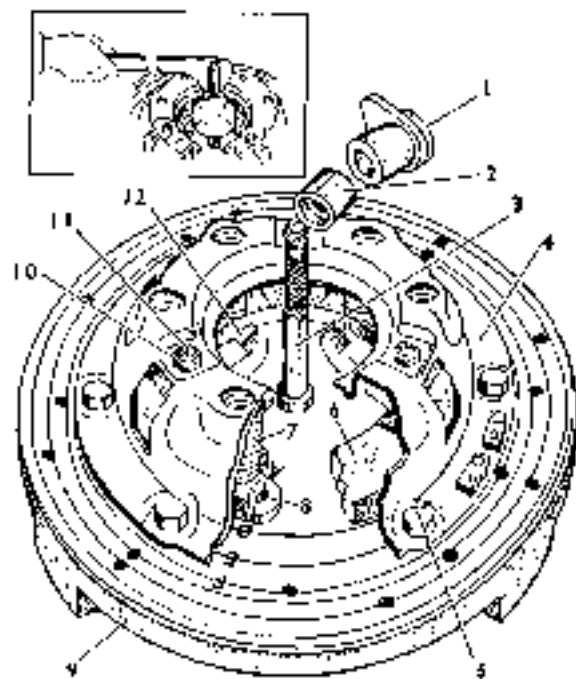

H.S. 118. A

Fig. 6. Clutch assembly tool, 180 99.

- |                    |                     |
|--------------------|---------------------|
| 1. Height finger.  | 7. Thrust springs.  |
| 2. Distance piece. | 8. Spacing washers. |
| 3. Centre pillar.  | 9. Base plate.      |
| 4. Clutch cover.   | 10. Locknuts.       |
| 5. Set pins.       | 11. Eye bolts.      |
| 6. Pressure plate. | 12. Release levers. |

Inset shows the clutch actuating mechanism in use



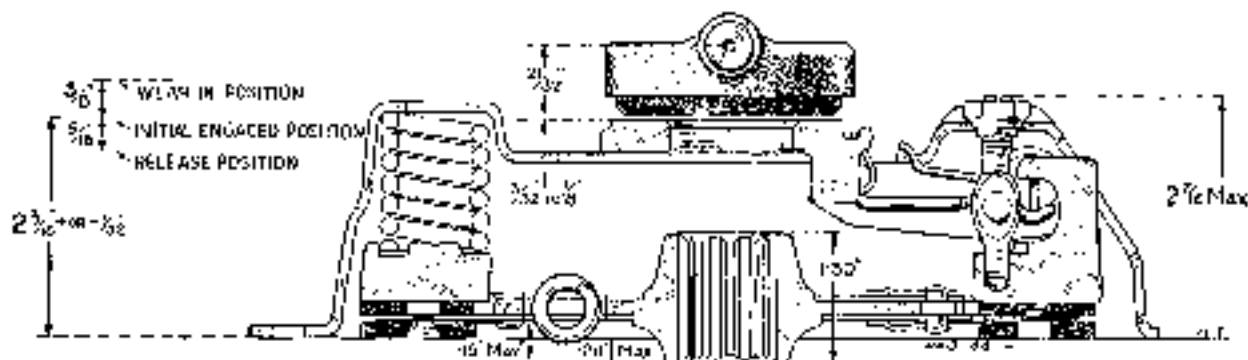

Fig. 7. A sectional diagram of the clutch unit showing the main dimensions for assembly.

Screw the centre pillar (3) into the base plate and slip the distance piece (2), (code 5 for 7 $\frac{1}{2}$ " clutch) over the pillar followed by the cam-shaped height finger (1). Adjust the height of the release levers by screwing or unscrewing the eye-bolt nuts until the height finger, when rotated, just contacts the highest point on the tip of the release levers (12).

Replace the height finger and pillar by the clutch actuating mechanism (see inset Fig. 6) and actuate the clutch several times by operating the handle. This will enable the parts to settle down on their knife-edges. Replace the height finger and distance piece and re-adjust the height of the release levers. Finally repeat the procedure to make quite sure the release levers are seating properly and gauge again.

Secure the eye-bolt nuts (10) and fit the release lever plate on the tips of the release levers (12) then secure by means of the three retaining springs.

Release the set screws (5), a little at a time, by diagonal selection and remove the clutch assembly from the base plate.

#### Refacing the Driven Plate

Should the facings of the driven plate require renewal, each rivet should be removed by using a  $\frac{1}{8}$ -in. (3.9687 mm.) diameter drill. The rivets should not be punched out.

Rivet one new facing in position, using a blunt ended centre punch, if the correct tool is not available, to roll the rivet shanks securely against the plate.

The second facing should then be riveted on the opposite side of the plate with the clearance holes over the heads already formed in fitting the first facing.

The plate should then be mounted on a mandrel between centres and checked for "run out" as near the edge as possible, if the error is more than .015-in. (.381 mm.) press over at the high spots until it is true within this figure.

It is important to keep friction facings free from oil or grease.

#### Refitting the Clutch

Place the driven plate on to the flywheel with the larger chamfered splined end of the driven plate hub towards the gearbox. The driven plate should be centralised by a dummy first motion shaft (see Tool No. CIT. 39) which fits the splined bore of the driven plate hub and the pilot bearing of the flywheel.

The clutch cover assembly can now be secured to the flywheel by means of the holding screws, tightening them a turn at a time by diagonal selection. There are two dowels in the flywheel to locate the clutch cover. Remove the dummy shaft after these screws are fully tightened.

Finally remove the dummy shaft and refit the withdrawal bearing and the gearbox. The weight of the gearbox must be supported during re-fitting in order to avoid strain on the first motion shaft and distortion of the driven plate assembly.

Finally adjust the clutch pedal for free travel.







# GEARBOX

## GENERAL DATA

Type:	Synchronesh on 2nd, 3rd, Top		
Gear Control:	...	Lever on Steering Column	
Number of Gears:	...	4 Forward, 1 Reverse	
Type of Gears:	...	Helical Constant Mesh	
Oil Capacity:	3 pints:	3.5 U.S. pints:	1.68 litres
Gear Ratios:	1st Speed	.. .. .	... 3.89 : 1
	2nd Speed	.. .. .	... 2.44 : 1
	3rd Speed	.. .. .	... 1.54 : 1
	4th Speed	.. .. .	... Direct
	Reverse	.. .. .	... 5.39 : 1
<b>Overall Gear Ratios—Saloon and Coupé:</b>			
	1st Speed	.. .. .	20.54 : 1
	2nd Speed	.. .. .	12.88 : 1
	3rd Speed	.. .. .	8.13 : 1
	4th Speed	.. .. .	5.28 : 1
	Reverse	.. .. .	28.46 : 1
<b>Overall Gear Ratios—Sports:</b>			
	1st Speed	.. .. .	20.111 : 1
	2nd Speed	.. .. .	12.52 : 1
	3rd Speed	.. .. .	7.89 : 1
	4th Speed	.. .. .	5.14 : 1
	Reverse	.. .. .	27.68 : 1
<b>Overall Gear Ratios—Commercials:</b>			
	1st Speed	.. .. .	23.89 : 1
	2nd Speed	.. .. .	14.95 : 1
	3rd Speed	.. .. .	9.43 : 1
	4th Speed	.. .. .	6.14 : 1
	Reverse	.. .. .	33.09 : 1

## BEARINGS

Layshaft, Front . . . . . Type Clevite Bush  
Diameter (inside) .676-.680-in. (1.717-1.727 cm.)

Layshaft, Rear . . . . . Type Clevite Bush  
Diameter (inside) .677-.683-in. (1.719-1.734 cm.)

### Third Motion Shaft, Front:

Type . . . . . Phosphor Bronze Bush  
Length . . .  $\frac{1}{2}$ -in. . . . . .005-in. (24.6 | .127 mm.)  
Dia. (outside) .9975-.9985-in. (2.533-2.536 cm.)  
Dia. (inside) .6255-.6265-in. (1.58-1.59 cm.)

### Third Motion Shaft, Centre:

Make . . . . . R. and M. M.J. 1 $\frac{1}{2}$   
(3 dot)  
Type . . . . . Ball Journal  
Size  $1\frac{1}{2} \times 2\frac{1}{16} \times \frac{1}{2}$  in. (28.5 x 21.4 x 20.6 mm.)

### Third Motion Shaft, Rear:

Make . . . . . R. and M. M.J. 1  
(3 Dot)  
Type . . . . . Ball Journal  
Size  $1 \times 2\frac{1}{8} \times \frac{1}{2}$ -in. (25.4 x 41.5 x 19.05 mm.)

### First Motion Shaft:

Make . . . . . R. and M. LJ35G  
(3 Dot)  
Type . . . . . Ball Journal (Light)  
Size . . . . . 35 x 72 x 17 mm.

## REMOVING THE GEARBOX

First disconnect one of the battery cables at its battery terminal and then the starter lead at the starter. Next release the flexible oil pipe at the union where the flexible pipe and gauge pipe join. Free the exhaust down pipe from the manifold by undoing three nuts and washers.

If the car is not over an inspection pit, block the rear wheels and raise the front of the car to a convenient underneath working height. Support the front wheels on suitable stands and raise one of the rear wheels to enable the propeller shaft to be rotated.

For ease of working, remove the cushions of the two

front seats. Peel back the floor carpet and remove the ten setpins, with their respective washers, which secure the gearbox cover. Lift off the cover.

Release the rear end of the propeller shaft from the axle flange by undoing four nuts and bolts, together with their lock washers. Before extracting the propeller shaft from the gearbox, place a tray beneath the rear end of the unit to catch surplus oil that may drain off.

Disconnect the clutch operating rod, by releasing the locknut and screwing the rod out of the pedal linkage. On models fitted with left-hand drive there is no need to disconnect the clutch pedal linkage, all

## A CUTAWAY VIEW OF THE GEARBOX

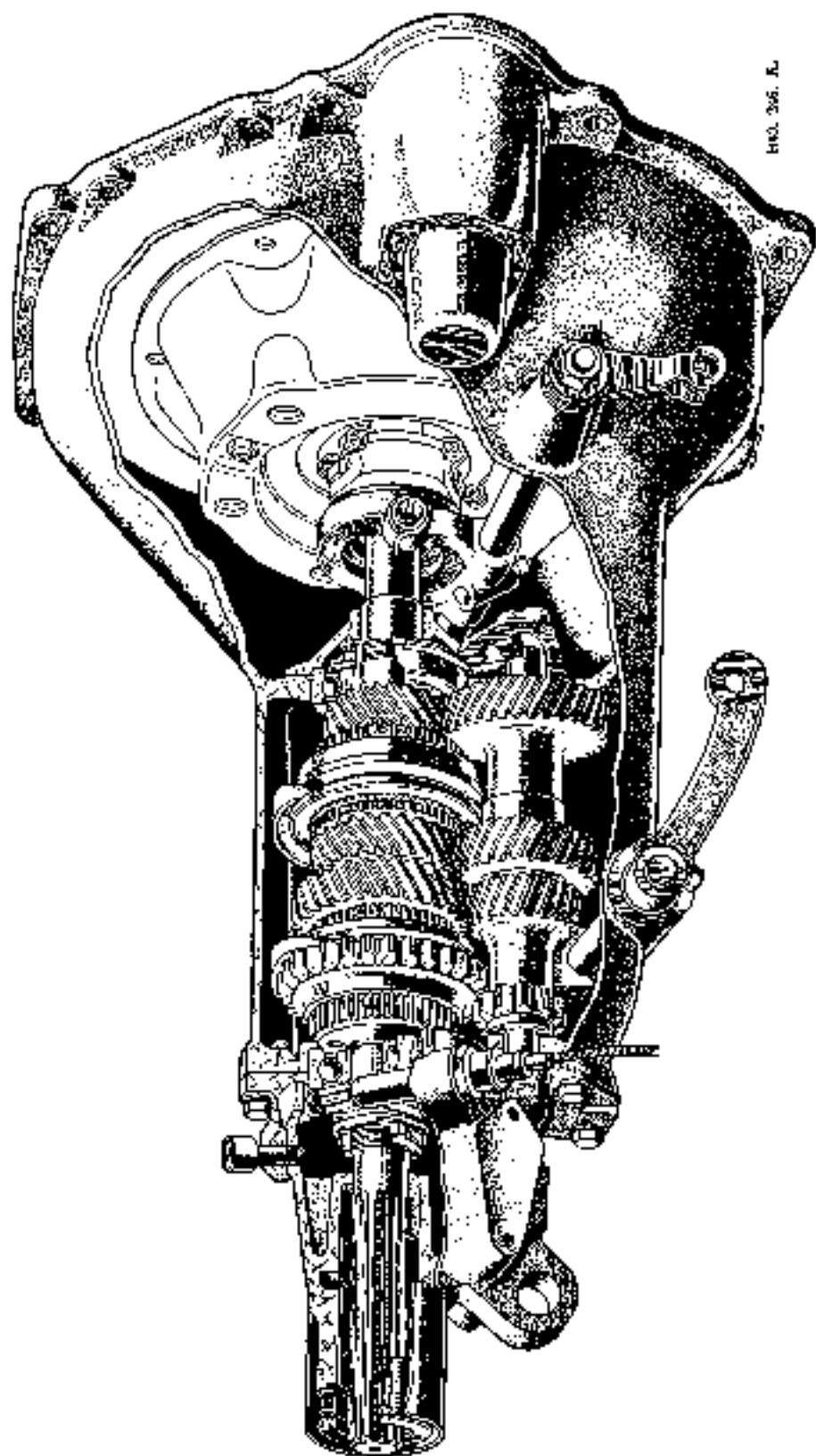

Fig. 1 This cutaway view of the gearbox clearly shows the assembly of the first and third motion shafts, also the layshaft.

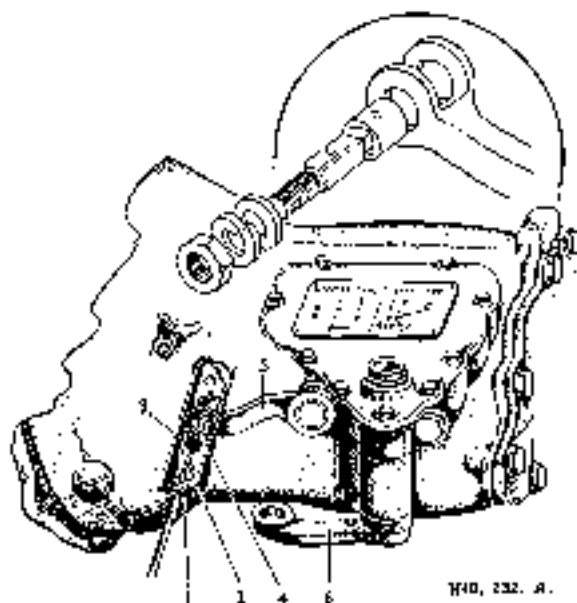

Fig. 2. Selector cable fitting.

1. Securing nut, 2. Cable, 3. Dust cover, 4. Cable securing bolt (exploded view in inset), 5. Selector lever, 6. Cross shaft lever.

that is entitled as the removal of the dumb-bell shaft. This is done by pushing the dumb-bell inwards against the tension of the operating shaft spring when the other end will be free of the linkage. Pull the dumb-bell rearwards, clear of the operating shaft.

By slackening the cable adjusting nut (see Fig. 2),

and unscrewing the union locknut, the change speed cable can be withdrawn from the gearbox operating arm, which is situated on the underside of the gearbox. To save bending the cable casing, disconnect the casing at its upper union nut and then turn the casing and cable to one side, out of harm's way. Release the fingertight, union cap of the speedometer cable, at the gearbox end, and then extract the cable from the gearbox.

Dismantle the connecting rod between the gearbox cross shaft lever and the gear change mechanism at both ends, this rod is secured by a ball and socket connection.

At this stage, support the rear end of the engine with packing or a suitable jack to relieve the load on the engine front mounting brackets when the gearbox becomes free.

Release the four nuts, bolts and washers securing the gearbox mounting bracket to the chassis, also remove the three stabiliser securing nuts, bolts and washers.

Commencing at the bottom of the gearbox, remove the various securing bolts or setpins holding the clutch housing to the engine rear flange. Note: Two of these fixing points hold the starter in place. Before finally releasing the top two securing points, support the gearbox from inside the car. Then as these bolts are removed, lower the engine a little and withdraw the gearbox first motion shaft from the flywheel bearing and the clutch. The gearbox can now be lowered to the ground.

Replacing the gearbox is a reversal of the removal procedure.

Fig. 3. Gearbox rear mounting and stabiliser assembly

1. Hinge pin,
2. Hinge pin rubber bushes
3. Rubber mounting-side,
4. Rubber mounting-lower
5. Mounting support,
6. Hanger plates
7. Rubber buffers,
8. Chassis stabiliser brackets
9. Distance tube,
10. Shockproof washers
11. Forked stay rod

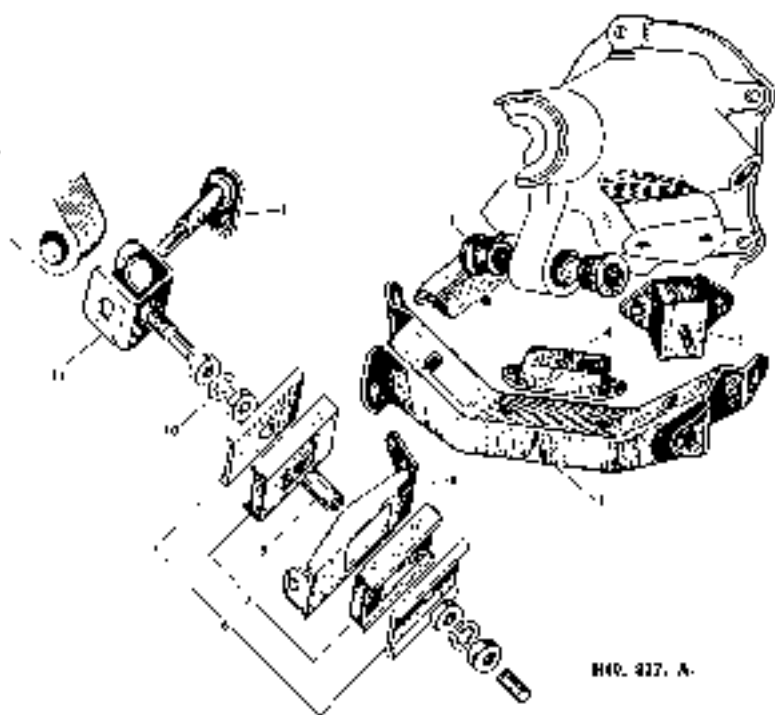

H40, 227, A.

## DISMANTLING THE GEARBOX

### Drain Plug

First drain the oil from the gearbox by removing the drain plug. The latter is situated beneath the gearbox at the left-hand side.

### Clutch Rod and Fork

Remove the nut and washer from the end of the clutch operating shaft and lift off the operating arm. From within the clutch housing, release the nuts and spring washers from the clutch fork outer pins, then tap the cotters from the operating fork. The clutch shaft may now be withdrawn from the housing, there being no need to disengage the circlip and washer from its left-hand side. If the car being operated on has left-hand drive, then the clutch shaft circlip and washer will be situated on the right-hand end of the shaft and must be removed before the shaft can be extracted.

### Cross Shaft Lever

The cross shaft lever is positioned on the right-hand side of the gearbox if the car has right-hand steering, and on the left for left-hand driven models. A cotter pin, spring washer and nut secure the lever to the shaft. After the nut and washer have been removed the pin may be tapped out and the lever lifted off the shaft.

### Front Cover

Release the front cover situated within the clutch housing by removing its seven nuts and spring washers. At this stage of dismantling do not attempt to remove the cover and joint washer. The operation will prove easier when the shift fork selector rods are tapped forward, thus pushing the cover away from the casing.

### Side Cover and Change Speed Gate

Holding the side cover in place are nine setpins with spring washers. The change speed gate is located by its two rounded ends, of the outer face, fitting into recesses in the gearbox side face. To release the gate from position it merely needs a gentle prising outwards with the aid of a screwdriver.

### Selector Arm and Cross Shaft

The selector arm is secured to its operating lever by a nut and tab washer. Bend back the tab of the washer and release the securing nut. To assist the latter operation, it is necessary to withdraw the operating arm as one works at the nut, thus giving the nut removal clearance.

Lift out the selector arm and then withdraw the cross shaft from its position, leaving the oil seal and felt washer in the housing. If need be, the oil seal and felt

washer can be tapped out. Extract the speedometer pinion and sleeve from the rear cover.

### Selector Rods, Forks and Rear Cover

Withdraw the eight rear cover setpins and slide the cover clear of the third motion shaft.

Using a soft metal drill, tap forward, for a short distance, each of the three selector rods and prise out the keys which are fitted to prevent the rods from turning.

Now drive each selector rod forward clear of the forks and extract them from the front of the gearbox. Care should be exercised in order that the spring loaded locating ball of each fork is not lost during this operation.

Lift out the three bronze forks, noting carefully their respective positions to assist reassembly. Fitted behind the third speed fork is a distance piece, which must be retrieved from the box when removing the respective fork.

### Reverse Gear

A lug, which is an integral part of the main casting, locates the forward end of the reverse gear shaft. To secure the shaft in position, a setpin is screwed through the lug locating in the shaft. The setpin is locked by a tab washer. Straighten the tab washer, release the setpin then tap forward and remove the reverse gear shaft. Lift out the reverse gear.

### Layshaft and Laygears

Using a bronze or other soft metal drift, drive the layshaft forward and out of the gearbox, when the

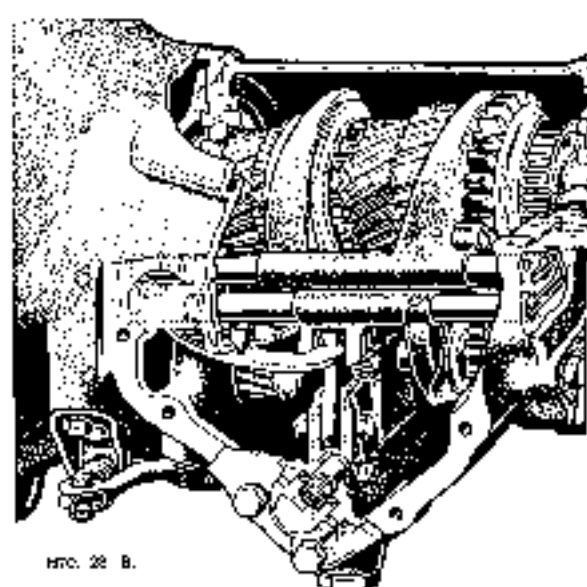

FIG. 22 B.

Fig. 4. A cutaway view of the left-hand side of the gearbox with the side cover removed.



laygear cluster and the two thrust washers will drop to the bottom of the box. These gears can only be lifted from the casing when the third and first motion shafts, together with their respective gears, have been removed.

### Third Motion Shaft

The third motion shaft can now be withdrawn from the gearbox casing.



Fig. 5. Removing the third motion shaft complete with gears.

To remove the gears from the third motion shaft, first slide off the third and top speed synchroniser assembly. Then depress the small spring loaded steel plunger, which locates the splined washer at the forward end of the third motion shaft, and turn the washer into line with the splines of the shaft. A peg spanner is a useful tool for turning the splined washer, the latter having two holes in its upper surface for turning purposes. The third and second speed constant mesh gears, together with their common phosphor bronze sleeve (made solid by a common thrust washer), can now be pulled over the steel plunger and so clear of the third motion shaft. Remove the steel plunger and its spring from the shaft.

Next remove the splined washer separating the second speed constant mesh gear assembly from the first gear unit, and then slide the first gear assembly free of the third motion shaft.

To release the speedometer wheel from the third motion shaft, straighten the tab washer and unscrew its securing nut and slide the speedometer wheel off the shaft. The third motion shaft bearing can be separated from its housing after the unit is prised from the shaft.

If it is desired to dismantle the top and third speed coupling sleeve, or the first speed gear, these can be pressed clear of their splined synchronisers, but care must be taken to retrieve the three balls and springs in each assembly.

Lift out the third motion shaft front bearing back from the end of the first motion shaft.

### Rear Oil Seal

This oil seal is situated in the end of the rear cover and should not be dismantled unless suspected of leaking. It is almost impossible to take off the seal without damaging it; consequently a new oil seal should be fitted if the old one has been moved.

To gain access to the oil seal it first becomes necessary to remove the steel dust cover. This cover is held to the gearbox rear cover by its being indented in three places into the groove provided. These indented lips have to be weakened by careful sawing with a hacksaw. Then the dust cover can be tapped from the rear cover by using a punch and hammer. Note: A new dust cover must be fitted on reassembly.

With the dust cover removed it will be discovered that the oil seal housing is pinched into position in a manner identical to that employed for the dust cover; therefore this, too, can be removed by the punch and hammer. However, there is no necessity to weaken the lips, as the 20 S.W.G. steel will give when punched off.

### First Motion Shaft

Before driving the first motion shaft from its position, tilt the laygears, now in the bottom of the

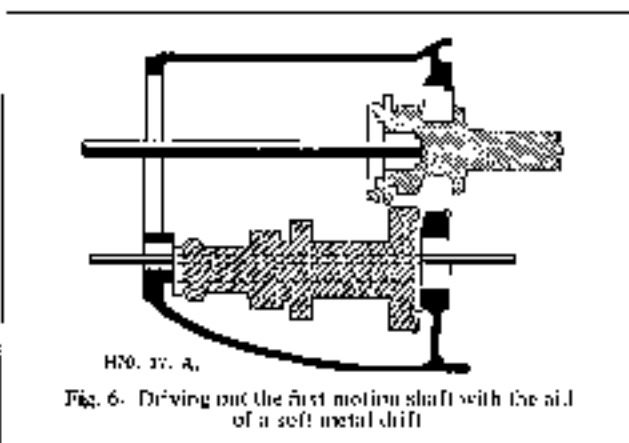

Fig. 6. Driving out the first motion shaft with the aid of a soft metal drift

gearbox, to clear the first motion shaft gear. Using a long drift, inserted through the third motion shaft opening, drive the first motion shaft forward, complete with bearing and circlip, from the gearbox.

The laygears may now be removed from the gearbox.

To remove the bearing from the shaft, knock back the tab locking washer and unscrew the shaft nut. This nut has a left-hand thread. The bearing can now be driven from the shaft, preferably by resting the circlip of the outer race on the jaws of an open vice and driving the shaft downward.

Use a hide or lead hammer for the operation, as great care must be exercised to prevent the end of the motion shaft from 'spreading'.



Fig. 7 The components of the gearbox.

Caption for Fig. 7.

1. 1st motion shaft nut.	33. 1st and 2nd selector rod	64. Synchroniser pinion sleeve
2. Locking washer	34. 1st and 2nd fork.	65. Oil seal.
3. 1st motion shaft bearing	35. Spring	66. Retaining ring
4. 1st motion shaft	36. Ball	67. Speedometer pinion
5. Bush bearing	37. Thrust washer	68. Pinion shaft
6. 3rd motion shaft	38. Lay gear	69. Rear cover.
7. Locking peg spring	39. Thrust washer	70. Breather
8. Locking peg	40. Lay gear shaft.	71. Dust cover.
9. Speedometer wheel nut.	41. Reverse gear shaft.	72. Oil seal.
10. Locking washer for nut	42. Reverse gear	73. Oil seal joint washer
11. Washer	43. Reverse gear	74. Clutch speed g. to
12. Speedometer wheel	44. Reverse gear fork	75. Input washer
13. 3rd motion shaft bearing	45. Starter pinion reverse	76. Selector arm nut
14. Housing for bearing	46. Setpin	77. Lub. w. seal
15. 1st gear	47. Washer	78. Plate washer
16. 2nd gear runner	48. Clutch casing	79. Seal, to cover.
17. Spring	49. Front cover.	80. Final or engagement lever.
18. Ball	50. Joint washer.	81. Engagement lever mounting
19. Thrust washer	51. Clutch pin cross hole	82. Ball
20. 2nd gear	52. Oil cup	83. Nut.
21. Coupling sleeve.	53. Rubber sleeve	84. Lock washer
22. Thrust washer	54. Bell bush	85. Cutter pin
23. Coupling sleeve.	55. Selector lever.	86. Castle nut
24. 3rd gear.	56. Selector lever spindle	87. Spring
25. Locking washer	57. Selector lever pin	88. Plate washer
26. 3rd and 4th synchroniser	58. Drum plug.	89. Joint washer
27. Spring	59. Cross shaft	90. Side cover
28. Ball	60. Locking washer.	91. Tube washer
29. Synchroniser sleeve.	61. Reverse shaft pin.	92. Side cover plug
30. 2nd and 1st fork.	62. {	93. Indicator plate
31. 3rd and 2nd selector rod.	63. } Selector of keys.	94. Sealing gait
32. Distance piece.		

## EXAMINATION FOR WEAR

### Clutch Cross Shaft Bushes

Should the cross shaft appear excessively loose in the bushes, new bushes must be fitted. These bushes are fitted in two parts with a gap left between the parts, thus providing an oil channel for lubrication via the oiling nipples.

### Bearings

The first and third motion shaft ball bearings may become worn after a considerable length of service and should be renewed if there are signs of looseness between inner and outer races.

### First and Third Motion Shaft Bush

This bush is fitted with a maximum permissible internal clearance of .003-in. (.0762 mm.) for the third motion shaft. When any appreciable wear above this figure occurs, the bush and shaft should be examined and renewed where necessary.

### Third Motion Shaft Sleeve

The phosphor bronze sleeve which carries the second and third speed gear assemblies must be replaced if the wear between shaft and sleeve appears excessive. The fitted clearance in a new gearbox is between .00025 and .00175-in. (.00635-.0444 mm.).

### Laygear Thrust Washers

These washers are designed to permit an end float for the layshaft cluster gear between .001 and .003-in. (.0254-.0762 mm.). If the end float exceeds this tolerance, the thrust washers must be renewed. The smaller thrust washer, positioned at the rear, is made in varying thickness to allow for correct end float to be obtained.

### Layshaft Bushes

The layshaft and layshaft bushes, in the cluster gear assembly, may become worn and need renewal. Both the front and rear bushes have an internal clearance of .002-.003-in. (.0508-.0762 mm.). These bushes are a press fit in the laygear.

### Gear Synchronising Cones

These cones are 'shrunk on' to the second, third and fourth speed gears, which are normally supplied as a complete unit for spare purposes. Where facilities exist for shrinking on and final machining, cones can be supplied separately. However, care must be taken in fitting if the gear is to operate satisfactorily.

The internal broaching of the cone is calculated to allow for a shrinkage fit on to the gear serrations, and the cone must be heat-expanded before it can be fitted. When heated in oil to approximately 250 degrees

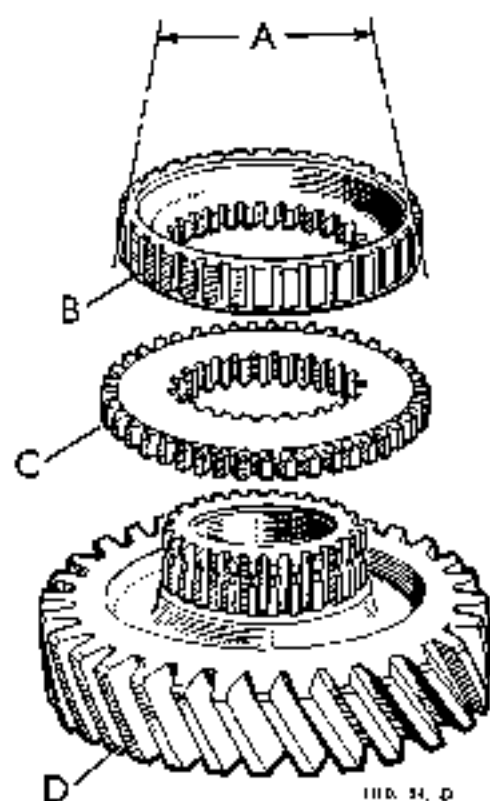

Fig. 8. Synchronising cone.

A. Chamfer to be machined after cone is shrunk into position. B. Cone. C. Coupling adaptor. D. Constant mesh gear.

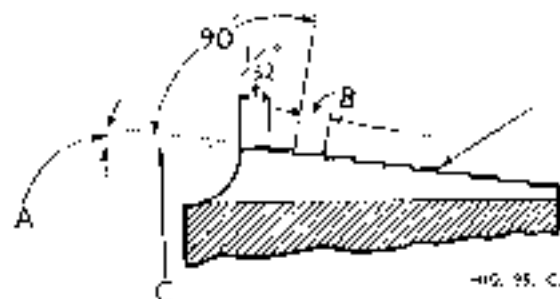

Fig. 9. Cone dimensions.

A. Cone angle  $5^{\circ} 10'$ . B. Coupling thread turned with .015-in. lead. C. Cone diameter 2.5-in.

Fahrenheit, expansion will allow the cone to be pressed home on to the gear without damaging the bronching and will be sufficiently close fitting to resist displacement in gear changing.

After shrinking on, the unit should be immediately quenched in water to prevent the heat softening the gear itself.

On each gear the appropriate speed coupling adaptor must be fitted before the cone, but there is no need to pre-heat this adaptor, which can be pressed home in the cold state. There is a shoulder on one side of the adaptor, and this must be facing the gear and not the cone.

When the cone is in position, the final machining can be done in accordance with the dimensions given in Fig. 9. The taper of the cone must be true and concentric with the bore to .001 in. (.0254 mm)

## ASSEMBLING THE GEARBOX

Perfect cleanliness of the gearbox parts is essential before assembly can commence. Although the following complete assembly operation has been subdivided, it is advisable for the operator to read the whole description before commencing any work—the sub-assemblies of the various parts are so interlaced with one another.

To reassemble the gearbox proceed as follows:—

### Synchronmesh Sub-Assembly

During manufacture both the 1st speed gear and the 3rd and 4th speed coupling sleeves are each paired with their respective synchronisers. Only mated pairs of these parts should therefore be refitted.

Special guides are available to facilitate the re-assembly of the three balls and springs into the synchronisers. The guide is of the same diameter as the coupling sleeve. (See Fig. 10.)

The guide is slipped over the synchroniser and turned until the hole coincides with one of the three sockets. A spring and ball are then placed in position,

the ball depressed and the guide rotated to hold it in place. This procedure is repeated for each spring and ball in turn until they are all depressed. The guide is

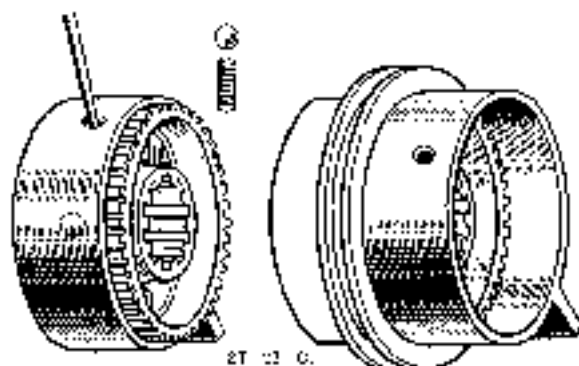

Fig. 10. Using Screw Test ISG-40 to assemble the spring loaded balls to a coupling sleeve and synchroniser.

then pushed further along the synchroniser splines, followed by the coupling sleeve.

As the coupling sleeve replaces the guide, the balls find their correct location in the coupling sleeve groove.

### Layshaft Gears

First locate the two thrust washers to the laygears, ensuring that the larger washer is at the front, and then place the gear cluster in the gearbox. Check that there is end play for the cluster gears of between .001 and .003 inch, and remedy if necessary by fitting a thicker or thinner rear washer. Temporarily replace the layshaft with a thin rod which will permit the gear cluster to remain out of mesh with the third and first motion shaft gears.

### First Motion Shaft Gears

Press the ball bearing on to the first motion shaft with the circlip in the outer race of the bearing facing forward. The bearing must be pressed on to the shaft as far as it will go. Refit the keyed washer and screw down and tighten the left-hand thread locking nut. Secure the nut with the locking washer.

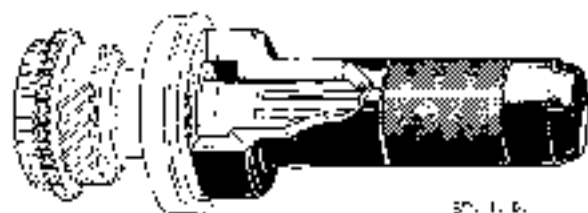

Fig. 11. Using Service Tool 1434 to assemble the bearing to the first motion shaft.

Using a bronze drift, tap the bearing, complete with the first motion shaft, into the forward face of the gearbox casing until the bearing circlip is flush with its recess in the casing.

### Third Motion Shaft

Press the third motion shaft centre bearing on to the shaft from the rear. The bearing must be pressed firmly against the shoulder of the centre splined portion of the shaft.

Lightly oil the shaft forward of the bearing and refit the first speed wheel assembly with the synchroniser pointing forward. Refit the keyed thrust washer on the shaft and assemble the second and third gears on to their phosphor bronze sleeves, which must be lightly oiled. These two sleeves are made solid by a common thrust washer (see 22, Fig. 7). The third speed, or small gear, must be placed on that end of the sleeve which has external splines. Slide the sleeve and gears on to the third motion shaft with the third gear to the front.

Place the spring and plunger into the hole in the third motion shaft and slide on the splined washer.

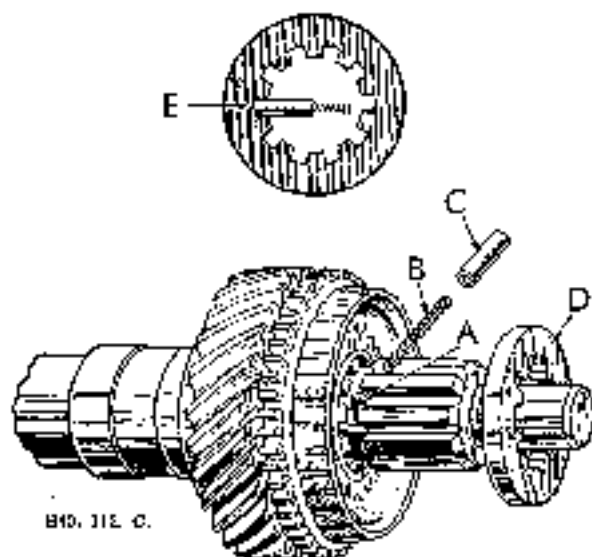

Fig. 12. Securing the third motion shaft gears.

A. Hole in shaft for locking peg. B. Spring. C. Locking peg. D. Locking washer. E. Locking washer with peg engaged.

Depress the plunger and slide the splined washer over the plunger. Then turn the washer for the plunger to engage with a groove in the washer.

The gears are now assembled on the third motion shaft and there should be end movement for the first speed gear between the centre bearing and the keyed washer at the rear of the second speed gear.



Fig. 13. Fitting the laygears into position with the aid of Service Tool 150 G.

Place the third and top speed synchroniser and coupling sleeve on to the third motion shaft, with the coupling sleeve groove for the change speed fork to the rear, and then oil and fit the phosphor bronze bush into the end of the first motion shaft. Slide the third and fourth synchronisers slightly forward on the shaft to clear the laygears, and then carefully guide the third motion shaft assembly into the gearbox casing. When the housing, surrounding the third motion shaft bearing, is flush with the gearbox casing, the layshaft gear cluster should be raised into mesh with the gears (see Fig. 13) and the layshaft oiled and fitted into position. The lipped

end of the layshaft must face forwards and the rear end must be flush with the gearbox casing.

### Reverse Gear

Refit the reverse gear into the gearbox casing with the large gear to the rear. Oil the reverse gear shaft before inserting and secure the shaft with the locating pin and tab washer.

### Selector Rods and Forks

Before commencing to locate the selector forks within the gearbox casing it is advisable to pre-load the spring and ball into each bronze fork, and with the aid of a pilot bar, as in Fig. 14, return the spring and ball in position until each fork rod has entered its correlative fork.

With the gears in the neutral position, first fit

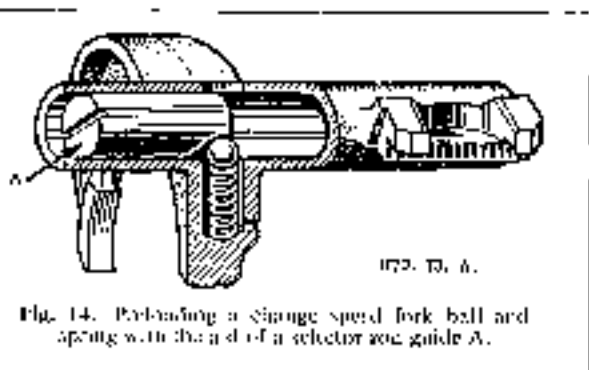

Fig. 14. Pre-loading a change speed fork ball and spring with the aid of a selector rod guide A.

the 3rd and 4th speed selector fork and then locate the 1st and 2nd speed selector. Now tap the 3rd and 4th selector fork rod through the casing, slide the distance piece over the rod and continue tapping the rod through its fork until it reaches its final position. Next locate the reverse gear fork and then enter the 1st and 2nd selector fork rod and the reverse gear fork rod, through the casing and into their respective forks.

Do not drive the two latter rods completely home until the change speed gate lever and its arm have been fitted to the box.

When driving the fork rods home remember to retrieve the pilot bars as they leave the forks.

### Selector Arm and Cross Shaft

Slide the cross shaft into its bearings. Replace the selector arm over the top of the lever, locating it on the two flats. Insert the cross shaft gear engagement lever between the forks on the selector arm and secure the latter by means of the nut and tab washer.

The selector fork rods may now be tapped right through the forks into their final position.

If the oil seal has been removed from the right-hand side of the gearbox, ensure that this item is tapped into place before fitting the cross shaft. Also make sure that the felt washer is fitted before fixing the lever to the cross shaft.

### Front Cover

The front cover and its paper joint washer should now be positional over the securing studs and fixed with the seven nuts and spring washers.

At this stage of the reassembly, the selector fork rods should be locked in place with the two keys in the gearbox rear face.

### Rear Oil Seal

Press on the new oil seal and maintain an even pressure around the end of the seal while it is pinched into its groove in three places. If this uniform pressure is not exerted while the seal is being secured, it will fail to seat evenly on its joint washer thus causing an oil leak for which the seal itself may be blamed.

In the same manner, fit the new dust cover. This cover must be held up hard against the rear cover of the gearbox and kept central whilst it is secured, thus ensuring that it does not rub on the propeller shaft when the latter is located.

### Rear Cover

Pass the rear cover, together with its joint washer, over the third motion shaft and secure it to the rear of the gearbox with the eight set-pins and spring washers, ensuring in the process that the third motion shaft is centralised within the cover. Now refit the speedometer pinion and sleeve.

### Change Speed Gate and Side Cover

The change speed gate should now be fitted into position. The gate is in the form of an angle plate: the side incorporating the gear stops slides into the gearbox (see Fig. 7), and the rounded ends of the outer side of the gate locate in two recesses which are bored into the gearbox side face. Secure the side cover into position by means of the nine set-pins and spring washers, ensuring that the joint washer is intact.

### Clutch Shaft and Fork

Slide the clutch shaft through the left-hand side of the clutch casing (in left-hand drive models the clutch shaft circlip and washer must be replaced), then position the clutch operating yoke on the shaft and pass the shaft through the right-hand side of the casing. Secure the yoke in place with the setler pin, spring washer and nut, and fix the operating lever to the end of the shaft by means of the washer and nut.

## THE GEAR CHANGE MECHANISM

### Description

The gear change lever situated on the steering column operates both a cable and mechanical linkage. By depressing or lifting the change lever the cable is either pulled or pushed, and thus turns the selector gate in the gearbox to select the desired gear.

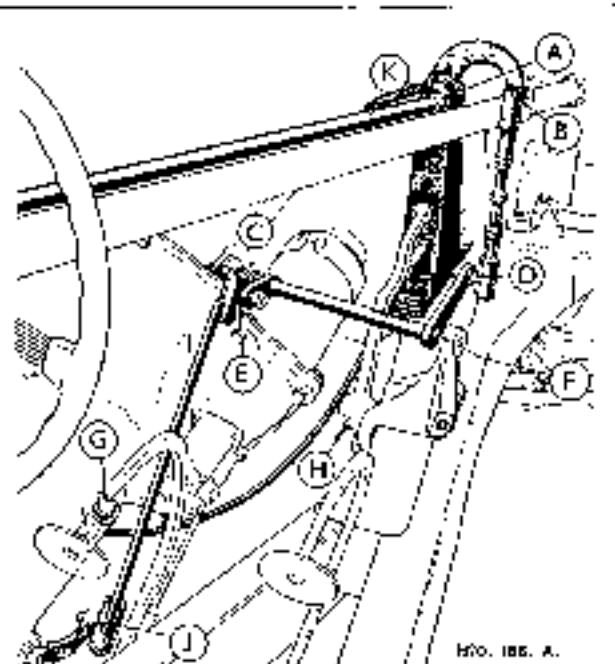

Fig. 15. The gear change and ciling points.

A. "C" lever pivot. B, D, E and J. Ball joint connections. C and F. Cross shaft bearings. G. Differential filler. H. Handbrake pivot. K. Selector return spring.

By moving the gear change lever forward, or rearward the gear selected is actually engaged via the mechanical linkage. When the gear lever is moved forward, the lever arm rotates clockwise moving with it the "C" lever at its base. The "C" lever, in its turn, forces downward the adjusting rod which in the same movement rotates the linkage cross shaft. Thus the inner arm of the cross shaft pulls upwards the connecting rod, which is attached at its lever end to the main gearbox cross shaft lever. In this way, 1st or 3rd gears are engaged.

If the lever is moved rearward, that is toward the driver, the whole linkage movement is reversed and the gearbox cross shaft lever is also moved to the rear. This movement engages the 2nd or 4th gears, or if the knob of the change lever has first been pulled outwards, the reverse gear.

A biasing spring K, Fig. 15 has been incorporated to facilitate the location of third gear. That is, when

disengaging second gear the spring ensures that the lever is pulled upward through neutral ready to engage third gear, thus obviating the crashing of first gear.

### Adjusting the Gear Controls

**Change Speed Cable:** Difficulty in gear selection may be caused by the inner cable slipping in the traction at either the steering or gearbox end, and should be remedied by adopting the following procedure:

Assuming that inner cable movement is occurring in the traction at the steering end, slacken off the nut securing the traction clamping bolt and, with the gear lever in neutral, slightly lift the "C" lever and push the inner cable downwards towards the gearbox to its fullest extent. Re-tighten the clamping bolt nut.

If the inner cable is slipping in the traction at the gearbox end, place the gear lever in neutral and release the clamping bolt nut. Push the selector lever to its fullest extent towards the rear of the gearbox and re-tighten the clamping bolt nut.

The procedure given for adjusting the inner cable at the gearbox end applies equally well when reconnecting the cable to a new or reconditioned gearbox.

**Mechanical Linkage:** Fitted between the "C" lever and the mechanism's cross shaft arm is an adjustment rod. When wear occurs in the linkage, the slackness may be taken up by releasing the lockout at each end of the adjuster, and then rotating the rod by its central hexagon. One end of the rod has a left-hand thread, the other a right-hand thread, thus when rotated the rod either shortens or extends the distance between the cross shaft and the "C" lever.

Adjustments of this nature are rarely required, probably only in the event of the complete dismantling

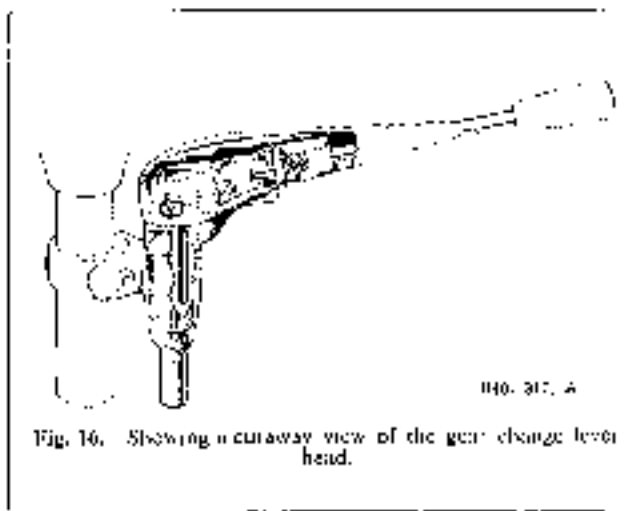

Fig. 16. Showing a cutaway view of the gear change lever head.

of the linkage. If wear occurs to the ball joints, then slight adjustment may be made at the joints themselves by releasing the split pin in the connector head and screwing up, slightly, the screw. After adjustment, relock the screw with a split pin.

#### Lubrication

Fig. 15 shows clearly the lubricating points of the gear change mechanism and if such lubrication is carried out regularly, namely at weekly intervals, there will be little likelihood of the controls failing or requiring adjustment.







# PROPELLER SHAFT

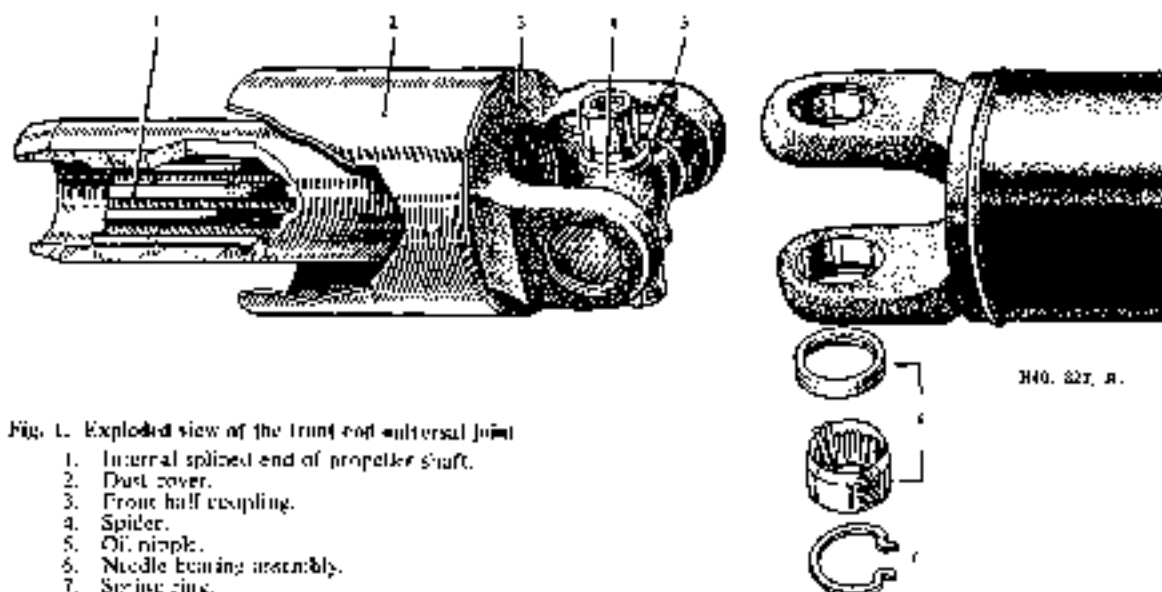

Fig. 1. Exploded view of the front end universal joint

1. Incurral splined end of propeller shaft.
2. Dust cover.
3. Front half coupling.
4. Spider.
5. Oil nipple.
6. Needle bearing assembly.
7. Spring ring.

## Description

The Propeller Shaft and Universal Joints are of Hardy Spicer manufacture (Fig. 1).

The fore and aft movement of the rear axle and other components is allowed for by a sliding spline between the propeller shaft and gearbox. Each universal joint consists of a centre spider, four needle roller bearings and two yokes. Reference to the Lubrication Chart in Section T shows the location of the joints.

## Lubrication

An oil nipple is fitted to each centre spider for the

lubrication of the bearings. Grease must not be used oil being the correct lubricant. Reference to Fig. 2 shows that the central oil chamber is connected to the four oil reservoirs and to the needle roller bearing assemblies.

The needle roller bearings are filled with oil on assembly. Gearbox oil lubricates the sliding splined joint between the propeller shaft and the gearbox. Before refitting the propeller shaft to the gearbox, smear the splines with oil.

## Tests for Wear

Wear on the thrust faces is located by testing the fit in the joint, either by hand, or by using a length of wood suitably supported.

Any circumferential movement of the shaft relative to the flange yokes, indicates wear in the needle roller bearings, or the sliding spline.

## Removal of Complete Assembly

**Safety:** Release the rear end of the propeller shaft from the axle flange by undoing four nuts and bolts together with their lock washers. Before extracting the propeller shaft from the gearbox, place a tray beneath the rear end of the unit to catch surplus oil that may drain off.

**Sports:** Due to the large amount of frame boxing necessary to provide chassis stiffness, the propeller shaft is embraced by a long tunnel. To remove or refit the

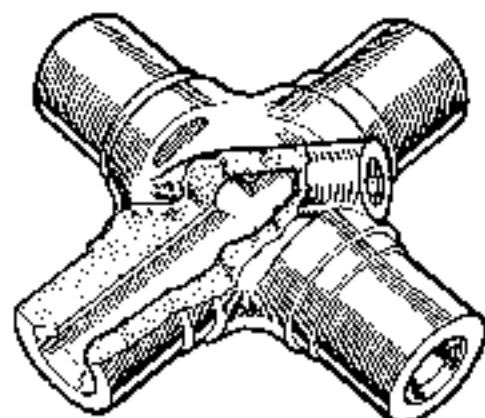

340. 110, A.

Fig. 2. Showing the oil channels in a joint spider.

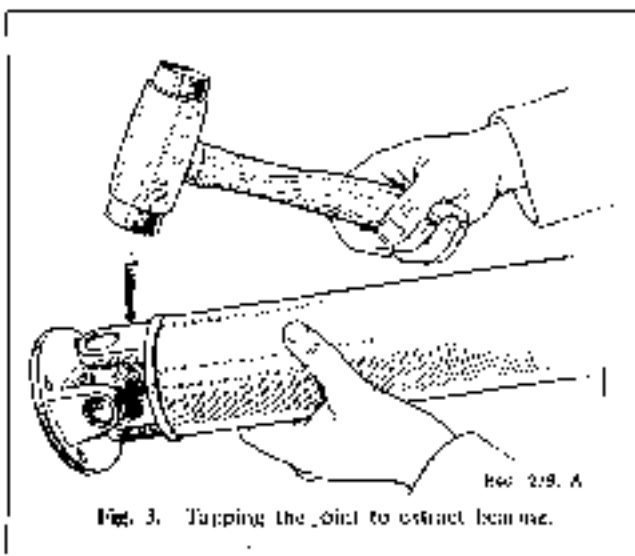

Fig. 3. Tapping the joint to extract bearing.

propeller shaft it is first necessary to jack up the rear end of the car and then place two trestles beneath the chassis, immediately before the rear springs.

Separate the propeller shaft from the axle flange by removing the four nuts, bolts and two locking plates. Now remove one rear road wheel and from the same side release the two rear spring "U" bolts. In addition, on the same side, disconnect the shock absorber link from its axle anchorage.

This allows the axle to be raised by a jack, away from one spring, permitting the propeller shaft to be withdrawn rearwards from its tunnel and so passed beneath the centre portion of the axle.

### Dismantling

Clean away the enamel from all the snap rings and bearing races, to ensure easy extraction of the bearings.

Remove the snap rings by pressing together the

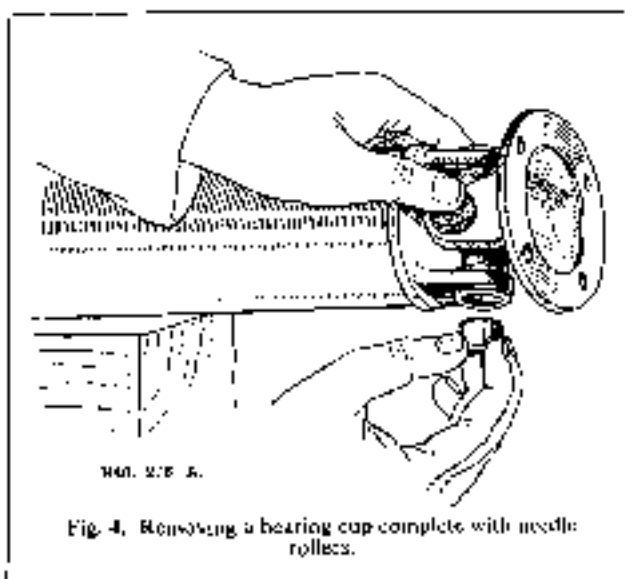

Fig. 4. Removing a bearing cap complete with needle rollers.

ends of the rings and extract with a screwdriver. If the ring does not come out easily, tap the bearing face lightly to relieve the pressure against the ring.

Hold the splined end of the shaft in one hand and tap the radius of the yoke with a lead or copper hammer (see Fig. 3), when it will be found that the bearing will begin to emerge. If difficulty is experienced, use a small bar to tap the bearing from the inside, taking care not to damage the race itself. Turn the yoke over and extract the bearing with the fingers (see Fig. 4), being careful not to lose any of the needles.

Repeat this operation for the other bearing, and the splined yoke can be removed from the spider (see Fig. 5).

Using a support and directions as above remove the spider from the other yoke.

### Examination and Checking for Wear

After long usage the parts most likely to show signs of wear are the bearing races and the spider journals.

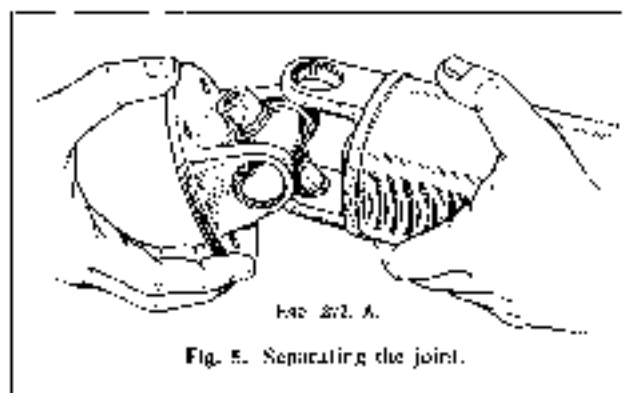

Fig. 5. Separating the joint.

Should looseness or stress marks be observed, the assembly should be renewed complete, as no oversize journals or bearings are provided.

It is essential that bearing races are a light drive fit in the yoke trunnions. Should any ovality be apparent in the trunion bearing holes, new yokes must be fitted.

### Reassembly

See that all drilled holes in the journals are cleared out and filled with oil (Fig. 2). Assemble the needle rollers in the bearing races and fill with oil. Should difficulty be experienced in assembly, smear the walls of the races with petroleum jelly to retain the needle rollers in place.

Insert the spider in the yoke. Using a soft-nosed drift about  $\frac{1}{2}$ -in. (12.7 mm.) smaller in diameter than the hole in the yoke, tap the bearing in position. It is essential that bearing races are a light drive fit in the yoke trunnions. Repeat this operation for the other three bearings. The spider journal shoulders should be coated with shellac prior to fitting the retainers to ensure a good seal.

If the joint appears to bind, tap lightly with a

wooden mallet, which will relieve any pressure of the bearings on the end of the journals. It is advisable to renew cork washers and washer retainers on spider journals, using a tubular drift.

#### Replacing the Shaft Assembly

Smear the propeller shaft splines with oil then slide

the splines into mesh with those of the gearbox third motion shaft.

Wipe the rear companion flange and flange yoke faces clean, to ensure that the pilot flange registers properly and the joint faces bed evenly all round. Insert the bolts, and see that the nuts are evenly tightened all round and are securely locked.









# FRONT HUBS AND INDEPENDENT FRONT SUSPENSION

## GENERAL DATA

### Hub Bearings

Inner R. & M. LJ 1 $\frac{1}{2}$ , Double Purpose Ball Journal (Light), Size 1 $\frac{1}{2}$  x 2 $\frac{1}{2}$  x  $\frac{1}{16}$ -in. (31.75 x 69.85 x 17.46 mm)

Outer R. & M. MJ  $\frac{3}{4}$ , Double Purpose Ball Journal (Medium), Size  $\frac{3}{4}$  x 2 x  $\frac{1}{16}$ -in. (19.05 x 50.8 x 17.46 mm)

Caster Angle ... .. 2 $\frac{1}{2}$ °

Camber Angle ... .. 1°

Swivel Pin Inclination ... .. 6 $\frac{1}{2}$ °

Swivel Pin Thrust Bearing: Oilite Washer between two stainless steel washers.

Swivel Pin diameter (top): .686 $\frac{1}{2}$  to .686 $\frac{7}{8}$ -in. (.743-1.744 cm.)

Swivel Pin diameter (bottom): .811 $\frac{1}{2}$  to .811 $\frac{7}{8}$ -in. (2.068-2.061 cm.)

### Swivel Pin Back Bearing

tolerance (top) ... .. .000 $\frac{1}{2}$  to .001 $\frac{1}{2}$ -in. (.019-.044 mm.)

### Swivel Pin Back Bearing

tolerance (bottom) ... .. .000 $\frac{1}{2}$  to .001 $\frac{1}{2}$ -in. (.019-.044 mm.)

### Independent Front Spring

\*Free Length ... .. 10.54 to 10.64-in. (26.77-27.02 cm.)

Number of Coils ... .. 8

Diameter of Wire ... .. .559-in. (1.42 cm.)

Inside diameter of coil ... .. 3.625-ins. (9.21 cm.)

Working coils ... .. 6 $\frac{1}{2}$

### Shock Absorber:

Armstrong hydraulic (double acting).

\*Note: New springs are  $\frac{1}{8}$ -in. (6.35 mm.) longer to allow for setting.

## FRONT HUBS

### To Check for Wear

The inner and outer ball bearings of the front hub are non-adjustable, the amount of thrust being determined by a collapsible distance piece. To check for wear of these bearings the car should be jacked until the wheel of the front hub is clear of the ground. Then grasp the tyre with both hands in the horizontal position and rock the wheel sideways. Movement between the wheel and the back plate denotes wear of the hub bearings. Should a very positive movement be apparent, the front hub bearings will need renewing.

### Dismantling the Front Hubs

To dismantle either front hub, first jack the car until the wheel is clear of the ground and then place blocks under the independent suspension spring plate. Lower the car on to the blocks.

Remove the wheel and the countersunk screw holding the brake drum clear of the front hub assembly. If the drum appears to bind on the brake shoes, the shoe adjusters should be slackened.

Unscrew the hub cap, taking care not to lose the fibre washer located inside the cap, and then extract the

Fig. 1. This illustration shows the front hub extractor (Savage Ford 1868J) in customary form. It should be noted that the extractor screws into position on the hub cap first.

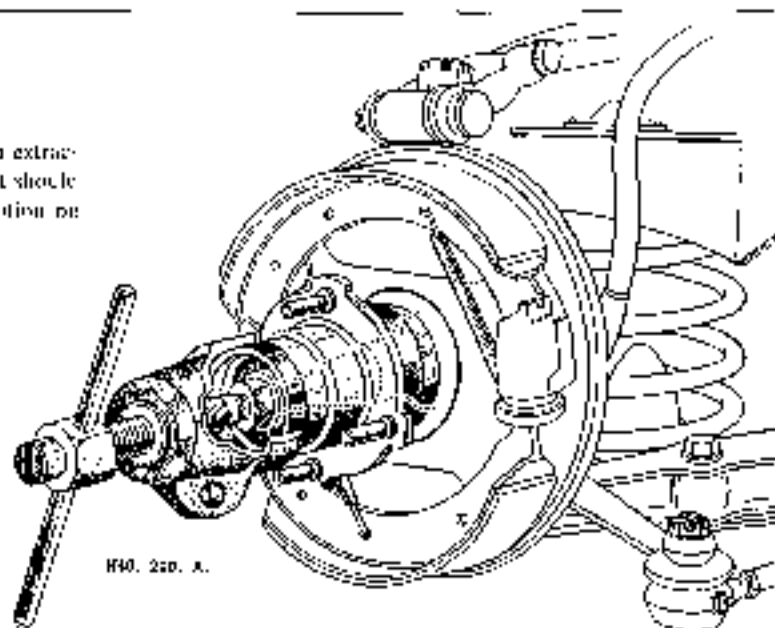

H40, 250, A.

Fig. 2. Front hub exploded.

- 1. Hub cap.
- 2. Axle nut.
- 3. Axle nut cover.
- 4. Flat washer.
- 5. Outer bearing.
- 6. Distance piece.
- 7. Wheel stud.
- 8. Hub.
- 9. Inner bearing.
- 10. Oil seal.

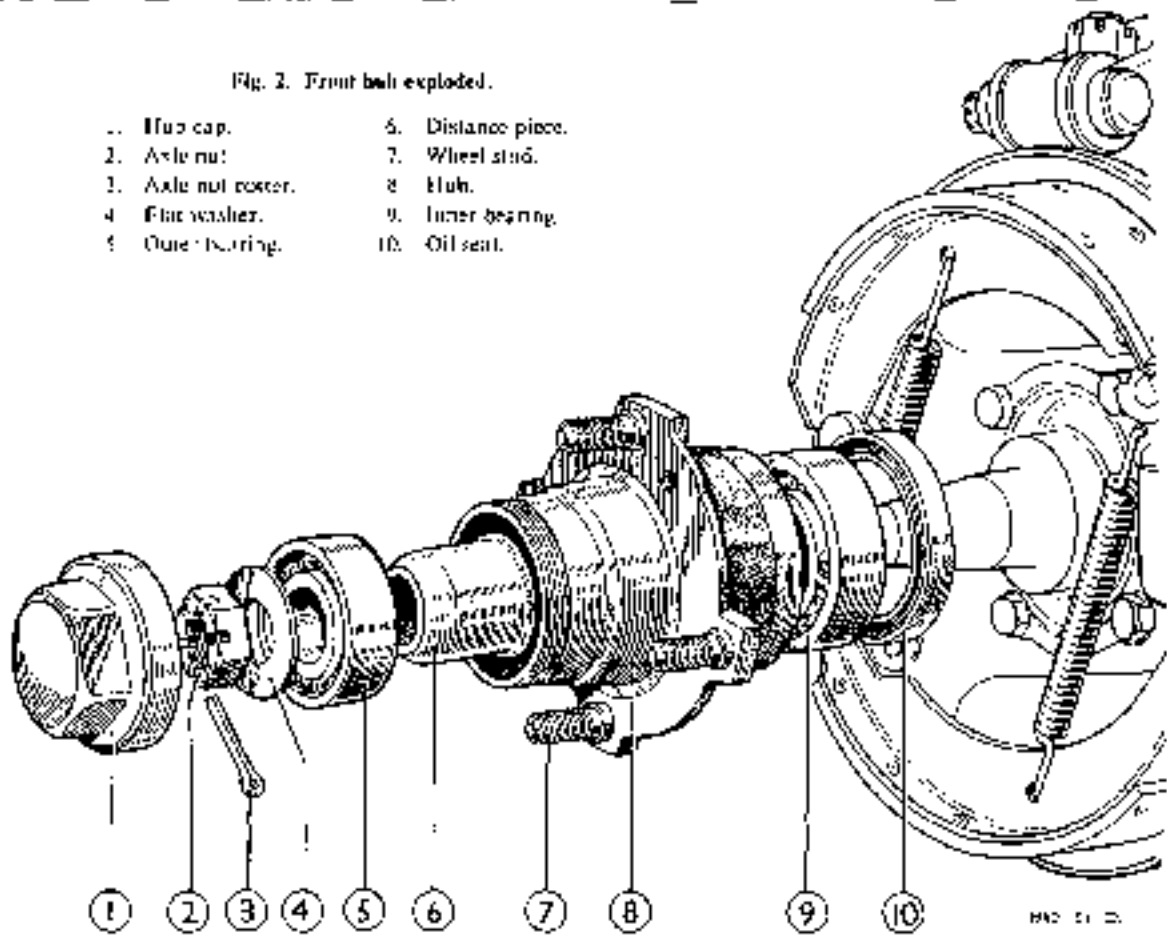

split pin from the swivel axle locking nut. Using a box spanner and tommy bar remove the axle nut and ease the flat washer, under the nut, clear of the axle thread.

The front hub can now be withdrawn by using an extractor. It is preferable to use an extractor which screws into position on the hub cap thread, but an extractor which fits over the wheel studs may also be used. The hub is withdrawn complete with the inner and outer bearings, the collapsible distance piece and the oil seal. Should the inner bearing remain on the swivel axle it can be removed by carefully inserting a narrow rod into the two small holes, in turn, in the back plate each side of the swivel axle and tapping the race lightly. If the extractor is used to remove the race there is a danger that the outer ring of the race will be pulled clear of the balls and the bearing will fall apart.

With the hub removed, the outer bearing and the collapsible distance piece can be dismantled by inserting a drift through the inner bearing and gently tapping the outer bearing clear of the hub. The inner bearing and oil seal can then be removed by inserting the drift from the opposite side of the hub.

The removal of the brake back plate is described fully in the section on brakes.

**Assembling the Front Hubs**

When assembling the hub the inner ball bearing race should first be inserted into the hub with the side of the race marked "thrust" facing the collapsible distance piece.

Pack the hub with recommended grease and then insert the collapsible distance piece so that the domed end faces the outer bearing.

Replace the outer bearing so that the "thrust" side faces the distance piece. Use a soft metal drift to replace both bearings, tapping them gently on diametrically opposite sides of the bearing to ensure they move evenly into their respective housings on the hub. Replace the hub oil seal over the inner bearing so that the hollow side of the seal faces the bearing. Renew the seal if it is damaged in any way.

The hub can now be replaced on the swivel axle. This is done by using a hollow drift which will bear evenly on both the inner and outer races of the outer hub bearing. Gently tap the hub into position until the inner race bears against the shoulder on the swivel axle.

Place the swivel axle flat washer into position and screw the nut down finger tight. Spin the wheel and note the resistance, which at this stage is due to the oil seal. Then continue tightening the nut until a slightly increased resistance to the spinning of the wheel is noticed. The bearings are now pre-loaded and the split pin should be inserted to lock the nut. Screw the hub cap and its fibre washer on to the hub after first packing the cap with grease.

Replace the brake drum and secure with the countersunk screw. It is important that the drum is fully home before this screw is tightened and, if necessary, the drum should be pressed in position by tightening two wheel nuts.

Refit the wheel. The wheel nuts are best finally tightened when the car is off the jacking blocks, but re-adjust the brake shoes if necessary before the car is lowered to the ground.

## INDEPENDENT FRONT SUSPENSION

### Description

The independent front suspension is known as the "wishbone" type, since the top and bottom linkages roughly conform to the shape of a wishbone. Between these two wishbones is the coil spring, held under compression between the top spring plate which is welded

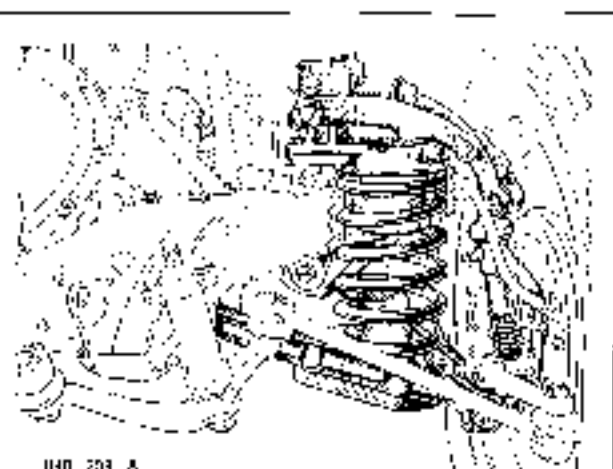

FIG. 3. A.

Fig. 3. A general view of the left-hand independent front suspension system with the suspension bracket cut away to show the coil spring seating.

to the chassis side member, and the lower spring plate which is secured to the lower wishbone by four bolts.

The top wishbone is secured at the chassis end to a double-acting hydraulic shock absorber which is anchored to the top spring plate bracket by four bolts. The two arms of the top wishbone thus form the operating levers of the shock absorber. At the swivel end, the top wishbone is secured to the swivel pin trunnion by means of a fulcrum pin and tapered rubber bushes. The bottom wishbone is secured by fulcrum pins and tapered rubber bushes to two brackets on the underside of the frame and by two screwed bushes and a screwed fulcrum pin to the lower end of the swivel pin.

### Checking for Wear

The following parts of the independent front suspension are liable to wear. Rectification may mean the fitting of new parts or assemblies.

**Swivel Pin and Bushes:** Wear of the swivel pin, or wear of the swivel pin bushes, or both, may be checked by jacking the front of the car and endeavouring to rock the wheel by grasping opposite points of the tyre in a vertical position. If any sideways movement can be detected between the top and bottom swivel pin trunnions and the swivel axle assembly, the swivel pin or the swivel pin bushes are worn and must be stripped for examination.

**Shock Absorber Bearings:** Up and down, or sideways movement of the shock absorber cross shaft, relative to the shock absorber casting, denotes wear of the shock absorber bearings which can only be remedied by refitting a new shock absorber. These bearings are best checked when the suspension is dismantled and when with some freedom of movement, it is possible to move the top wishbone arms, which are attached at their inner ends to the shock absorber cross shaft.

**Wishbone Arm Rubber Bushes:** The rubber bearing bushes used for the upper wishbone arm outer bearings and for the lower wishbone arm inner bearings may in time deteriorate and need renewing. Excessive sideways movement in either of these bearings would denote softening of the rubber bushes.

**Wishbone Arm Screwed Bush Bearing:** The screwed bushes or the screwed trunnion fulcrum pin of the lower wishbone arm bearing assembly may develop excess free play due to wear of either of these parts. This assembly can best be checked when the suspension has been dismantled.

### Removing the Coil Spring

Jack the side of the car concerned and place blocks under the frame side member to the rear of the suspension assembly.

In the absence of Service Tool 18G 37, two 3-in. (76.2 mm) B.S.F. slave bolts will be required to release the compression from the coil spring. These bolts should be of high-tensile steel, 4-in. (101.6 mm) long and threaded their entire length.

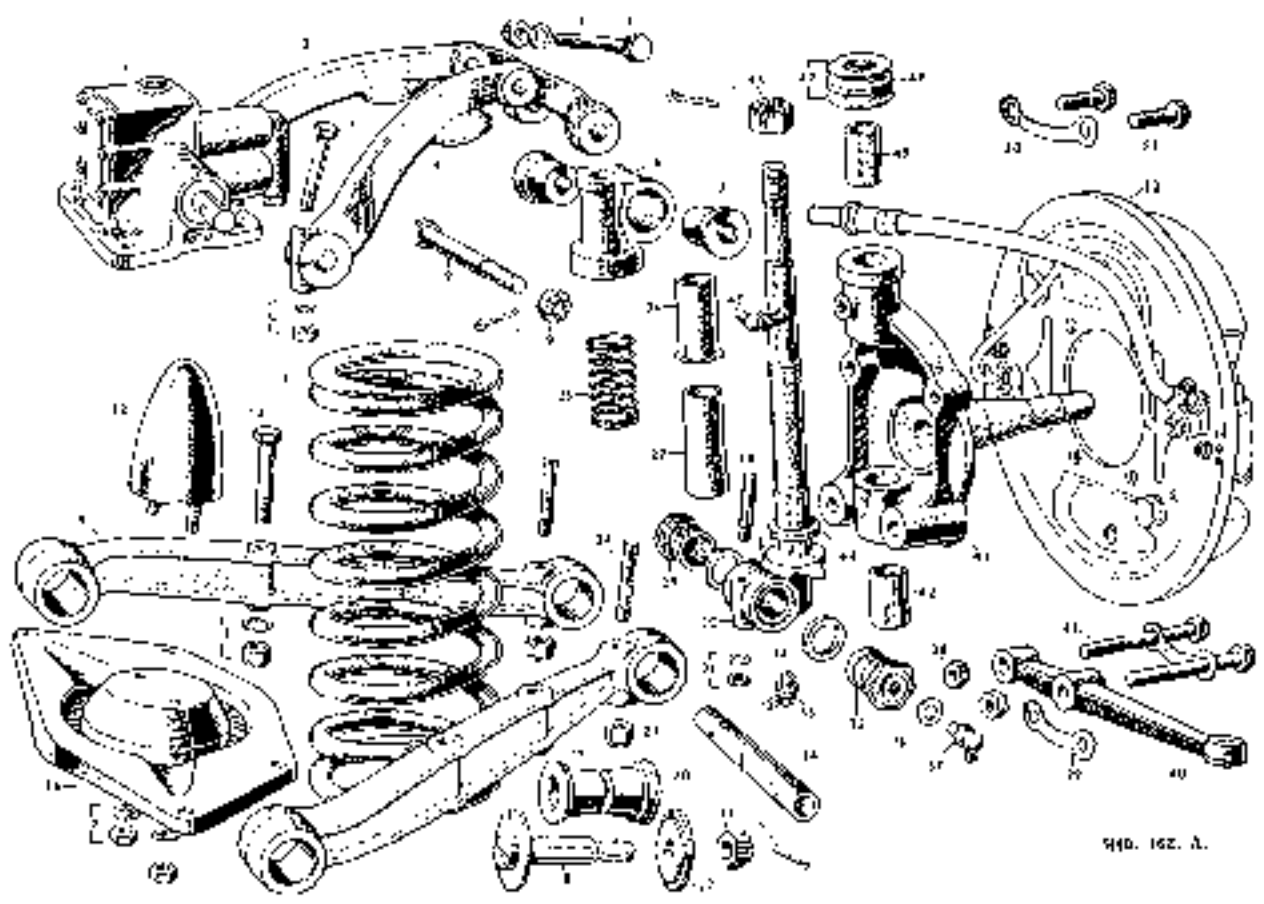

940. 162. A.

Fig. 4. Components of the independent front suspension.

- |   |  |                                  |
|---|--|----------------------------------|
| 1 Shock absorber                            | 18. Fikrum pin for inner lower bearing | 35. Front screwed bush.          |
| 2 Rear top wishbone nut                     | 19. An inner lower rubber bearing.     | 36. Flat washer.                 |
| 3 Clamping bolt for front top wishbone arm. | 20. An outer lower rubber bearing.     | 37. Grease nipple.               |
| 4 Front top wishbone arm.                   | 21. Fikrum pin nut and collar.         | 38. Steering arm nut.            |
| 5 Clamping bolt for top wishbone arm.       | 22. Fikrum pin special washers.        | 39. Steering arm nut lockwasher. |
| 6 Upper transion link.                      | 23. Nut for bush center.               | 40. Steering arm.                |
| 7 Friction rubber bearing                   | 24. Bush center.                       | 41. Steering arm bolt.           |
| 8 Upper transion fork nut pin               | 25. Swivel pin dust cover spring.      | 42. Swivel axle lower bush.      |
| 9 Fulcrum locking nut and collar.           | 26. Upper dust cover.                  | 43. Swivel axle.                 |
| 10 Nut and washer for clamping bolt         | 27. Lower dust cover.                  | 44. Cork ring.                   |
| 11 Coil spring.                             | 28. Center for fikrum pin.             | 45. Swivel grease nipple.        |
| 12 Rebound rubber bumper.                   | 29. Rear screwed bush.                 | 46. Swivel pin nut and collar.   |
| 13 Spring plate bolt.                       | 30. Swivel pin and lower transion.     | 47. Stabrite washers.            |
| 14 Rear lower wishbone arm.                 | 31. Nut and washer.                    | 48. Oilite washer.               |
| 15 Steering arm nut and lockwasher.         | 32. Cork ring.                         | 49. Swivel upper bush            |
| 16 Spring plate.                            | 33. Friction grease nipple.            | 50. Back plate bolt lockwasher.  |
| 17 Rebound bumper nut and washer.           | 34. Screwed fikrum pin.                | 51. Back plate bolt.             |
|   |  | 52. Back plate assembly          |

There are four nuts and bolts securing the bottom spring plate to the suspension lower links, the nuts being of the self-locking type. Unscrew the nuts from two diagonally opposite bolts. Remove these bolts and insert the two slave bolts in the vacated holes. Screw their nuts down securely and then remove the remaining two short bolts. Unscrew the nuts from the slave bolts, each a little at a time. When the spring is fully extended, release the bolts and remove the spring plate and coil spring.

**Checking the Spring:** The spring should be checked for a correct free length as given on page H/1. The spring should be renewed if there is any excessive variation in its correct length.

**Refitting the Coil Spring**

After the coil spring and spring plate into position, fit the slave bolts if Service Tool 18G 37 is not available, and screw down their nuts, each a little at a time until the spring plate is held tightly against the suspension

lower wishbone arms. Fit two short bolts into the vacant holes and secure with the nuts. Remove the slave bolts and fit the remaining two short bolts. See that all nuts are securely tightened.

### Removing the Suspension

Jack the car, remove the wheel and the coil spring as already explained. Disconnect the steering side-tube from the steering arm by withdrawing the split pin and unscrewing the nut. Also disconnect the flexible brake fluid pipe at its union on the chassis, plugging the main pipe to save loss of fluid.

With the suspension unit supported, remove the fulcrum pins securing the lower wishbone arms to their brackets under the frame, taking care to retrieve the two rubber bushes and special washer from each bearing. Unscrew the four nuts securing the shock absorber to the top spring bracket and withdraw the bolts. The suspension unit is now free to be lifted clear.

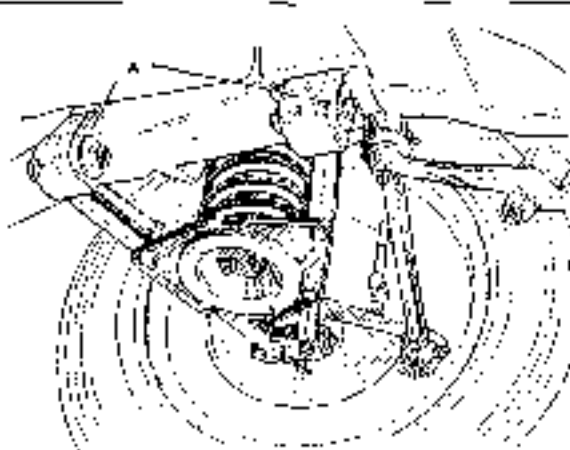

Fig. 5. The position of the bushes and washers of the lower wishbone arms are indicated at 'A'.

### Dismantling the Suspension

The top wishbone arms are connected at their narrowest point by a clamping bolt. Unscrew the nut and release this bolt. Next remove the split pin and nut from the upper trunnion fulcrum pin on the outer end of the top wishbone arms.

The forward arm of the top wishbone is secured to the shock absorber spindle by a clamping bolt. Slacken the clamping bolt and partially withdraw the arm. The trunnion fulcrum pin can now be withdrawn and the shock absorber removed complete with the top wishbone arms and packing piece.

Withdraw the rubber bearing from each end of the upper trunnion. These bearings fit into a groove in the swivel pin and must be taken out before the swivel pin can be removed. Remove the split pin and unscrew the nut from the top of the swivel pin. Remove the upper

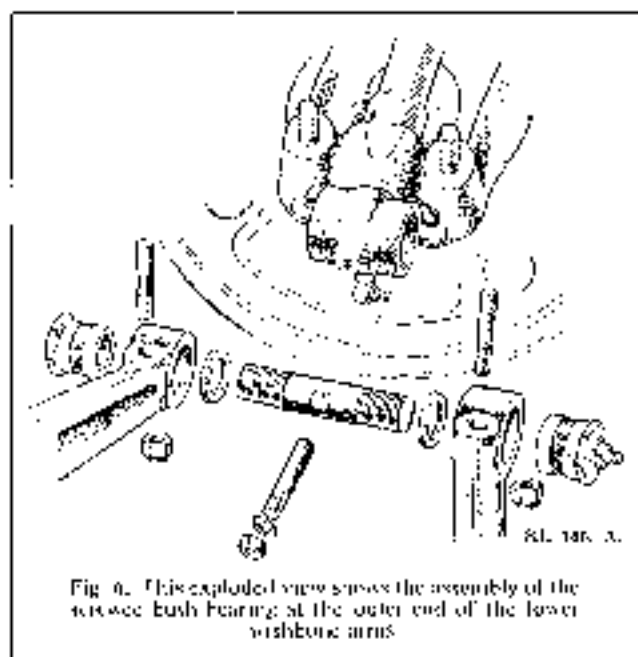

Fig. 6. This exploded view shows the assembly of the swivel bush bearing at the outer end of the lower wishbone arms.

trunnion and the three thrust washers and lift off the swivel axle and hub assembly. Detach the cork washer from the lower end of the swivel pin.

The outer bearing of the lower wishbone arms can now be dismantled. Slacken the nut on each of the half-moon cutters located in the ends of the lower wishbone arms, screw out the two threaded bushes and detach the arms.

Unscrew the nut from the cotter located in the centre of the lower trunnion and tap out the cycle-type cotter. Withdraw the fulcrum pin and remove the cork washer from each end of the trunnion.

The suspension unit is now dismantled, and worn or damaged parts can be renewed.

### Examination for Wear

**Swivel Pin:** If wear of the swivel pin and bushes is suspected as described earlier, carefully examine the swivel pin for wear by checking for ovality with a micrometer gauge. Should the pin not show any appreciable signs of wear renewal of the swivel bushes may effect a satisfactory cure. These bushes can be easily driven out and replaced with a suitable drift. When refitting the top bush the oiling hole must locate with the oil hole in the swivel housing and the top of the bush must be flush with the top of the swivel housing. The second bush must be flush with the recess at the bottom of the lower swivel housing and protrude about  $\frac{1}{4}$  of an inch (3.175 mm.) above the upper face. Then reenter the bushes from the bottom as necessary with Service Tools Nos. 18G 64 and 18G 65.

The two piece dust cover for the swivel pin is easily removed and replaced by telescoping the spring loaded tubes.

**Wishbone Arm Screwed Bush Bearings:** If it is found that the screwed bushes can be moved backwards or forwards on the fulcrum pin thread they should be renewed. Should new screwed bushes on the old fulcrum pin still permit end play, then renew the fulcrum pin.

**Shock Absorber:** The cross shaft bearings of the double acting hydraulic shock absorber may have worn sufficiently to permit up and down or sideways movement of the cross shaft. If such wear is apparent the shock absorber must be renewed complete.

The shock absorber should also be carefully examined for any leaks and tested for effective damping. Secure the shock absorber mounting plate in a vice and move the top wishbone arms up and down through a complete stroke. A moderate resistance throughout the full stroke should be felt.

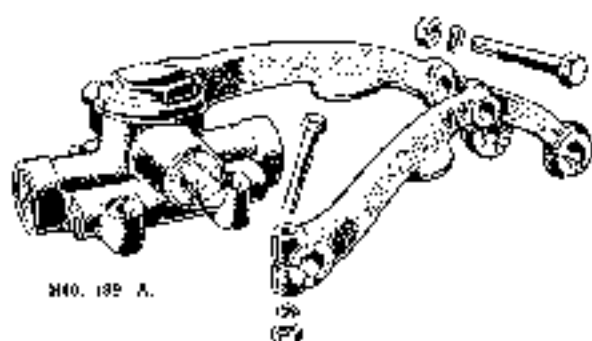

Fig. 7 Showing the Girling front shock absorbers and top wishbone arms.

If resistance is erratic it may mean that the fluid level is too low and that there are air locks in the shock absorber. To rectify this, the shock absorber filler plug should be removed and the fluid level maintained to just below the filler plug opening, while the lever is moved steadily up and down through full strokes. If this treatment does not effect a cure the shock absorber must be renewed as a complete unit.

On the A40 Sports the shock absorbers are of Girling manufacture (See Fig. 7), and though they differ in appearance from the Armstrong type, their principle of operation is similar.

#### Assembling the Suspension

First fit the screwed fulcrum pin into the lower transom at the bottom end of the swivel pin, ensuring that it is centralised and secured by means of the cycle-type cotter. Fit a cork ring into the recess provided in each end of the lower transom and introduce the lower wishbone arms into position. Ensure that the half-moon cotters are correctly positioned to receive the steel bushes which should now be greased and screwed partly home.

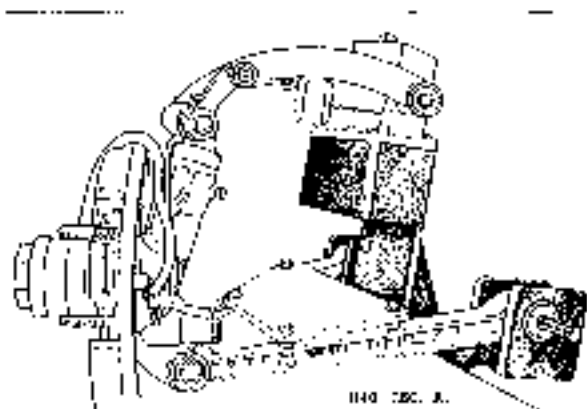

Fig. 8. Illustrating the suspension assembly, fit the Service Tool 18G 89.

To ensure that the alignment of the lower wishbone arm is correct, it is necessary, in the absence of a suitable jig, to lock the lower spring plate securely in position. Screw the threaded bushes home evenly, and then slacken them back one flat. Finally secure the bushes by tightening the nuts on each of the two half-moon cotters. Do not over-tighten the cotter nuts as this may cause distortion of the bushes. If the assembly has been correctly carried out it will be possible to insert a .002-in. (.0508 mm.) feeler gauge between the inner shoulder of the bush and the outer face of the wishbone arm on each side. The lower transom assembly should now operate freely in the screwed bushes.

Place the cork washer on the swivel pin with its chamfered face downward and smear the swivel pin with a little clear engine oil. Then position the swivel axle and hub assembly on the swivel pin. The thrust washers, comprising one "Oilite" washer interposed between two "Staybrite" washers should next be fitted. The "Staybrite" washers are supplied in varying thicknesses to permit adjustment, as it is necessary to provide easy operation of the swivel axle with a minimum amount of lift. The maximum permissible lift is .002-in. (.0508 mm.). Fit the upper transom and swivel nut, and check the clearance correcting it if necessary by means of the "Staybrite" washers. Then slacken the swivel pin nut to permit further assembly.

Moisten the upper transom rubber bearings with water and place them in position. The transom with its bearings should next be placed in position between the two upper wishbone arms, after which the fulcrum pin should be fitted and the slackened upper wishbone arm repositioned and tightened to the shock absorber shaft. Secure the clamping bolt located between the two shock absorber arms.

Note that the swivel pin and upper transom fulcrum pin nuts must not be tightened at this stage.

### Replacing the Suspension

Fit one rubber bearing in each of the suspension lower links, on the side which corresponds to the small hole in each of the frame brackets.

Raise the links to the frame brackets, insert the fulcrum pins and slide the second bearing and special washer over the protruding end of each pin. Fit the nut but do not screw it home. Position the shock absorber and packing piece on its bracket and partly tighten the four setscrews.

The assembly must next be set in the normal loaded position. This can be accomplished by placing a distance piece between the shock absorber front wishbone arm and the upper spring plate, at a point opposite to the rubber buffer. The length of the distance piece must be  $2\frac{1}{4}$  in. (5.71 cm.). The final adjustments can now be effected as follows:—

1. Tighten the nuts on the fulcrum pins securing the lower wishbone arms to the frame brackets. Do not forget to lock them with split pins.
2. Tighten the four setscrews securing the shock absorber to its bracket on the frame.
3. Tighten the upper trunion fulcrum pin nut and secure with a split pin.
4. Tighten the swivel pin nut and lock with a split pin.

The jig, or lower spring plate, whichever is used,

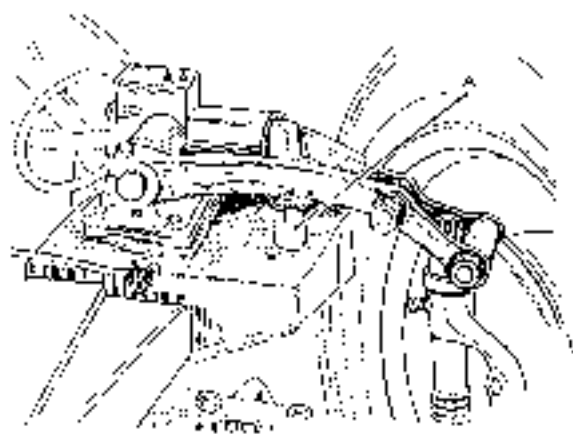

Fig. 9. When building up the suspension the arms must be correctly set by the distance piece (A) before the various bearings are tightened. Its length should be  $2\frac{1}{4}$  in.

should now be removed from the lower wishbone arms, and the coil spring refitted as already described.

Connect the brake fluid pipe to the brake backplate, secure the steering side-tube to the steering arm, refit the road wheel, lower the wheel to the ground and remove the distance piece used to retain the suspension in the normal loaded position.

Finally, bleed the brakes as described in Section M

## CASTOR AND CAMBER ANGLES AND SWIVEL PIN INCLINATION

### Description

The castor and camber angles and the swivel pin inclination are three design settings of the front suspension assembly. They have a very important bearing

on the steering and general riding of the car. Each of these settings is determined by the machining and assembly of the component parts during manufacture. They are not therefore adjustable.

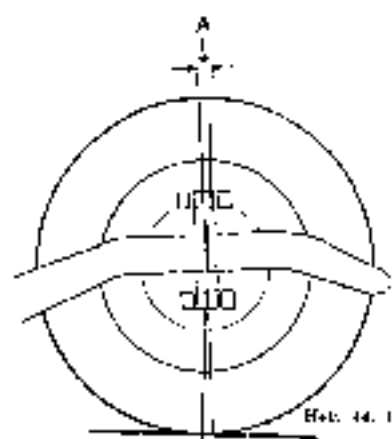

A. Castor angle  $2\frac{1}{2}^\circ$ .

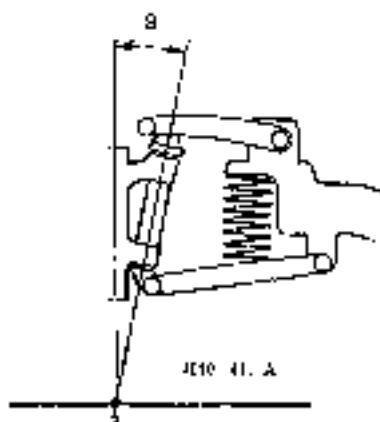

B. Swivel pin inclination  $6\frac{1}{2}^\circ$ .

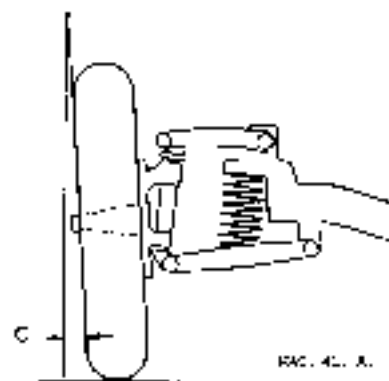

C. Camber angle  $1^\circ$ .

However, should the vehicle suffer damage to the suspension affecting these settings, the various angles must be verified to ensure whether replacements are necessary.

**Camber Angle:** This is the outward tilt of the wheel and a rough check can be made by measuring the distance from the outside wall of the tyre, immediately below the hub, to a plumb line hanging from the outside wall of the tyre above the hub. The distance must be the same on both front wheels. It is very important to ensure before making this test that the car is on level ground and that the front tyres are in a uniform condition and at the same pressure, and that the car is unladen.

Damage to the upper and lower wishbone arms may well affect the camber angle.

**Caster Angle:** This is the tilt of the swivel pin when viewed from the side of the car. This also is only likely to be affected by damage to the upper and lower wishbone arms.

**Swivel Pin Inclination:** This is the tilt of the swivel pin when viewed from the front of the car and is again only likely to be affected by damage to the wishbone arms.

A useful service tool which can be used for checking these settings is the Dunlop "Wheel Camber, Castor and Swivel Pin Gauge". See Fig. 11. With the car standing on perfectly level ground this gauge will give readings enabling the castor, camber and swivel pin angles to be quickly verified. Full details of this gauge can be ob-

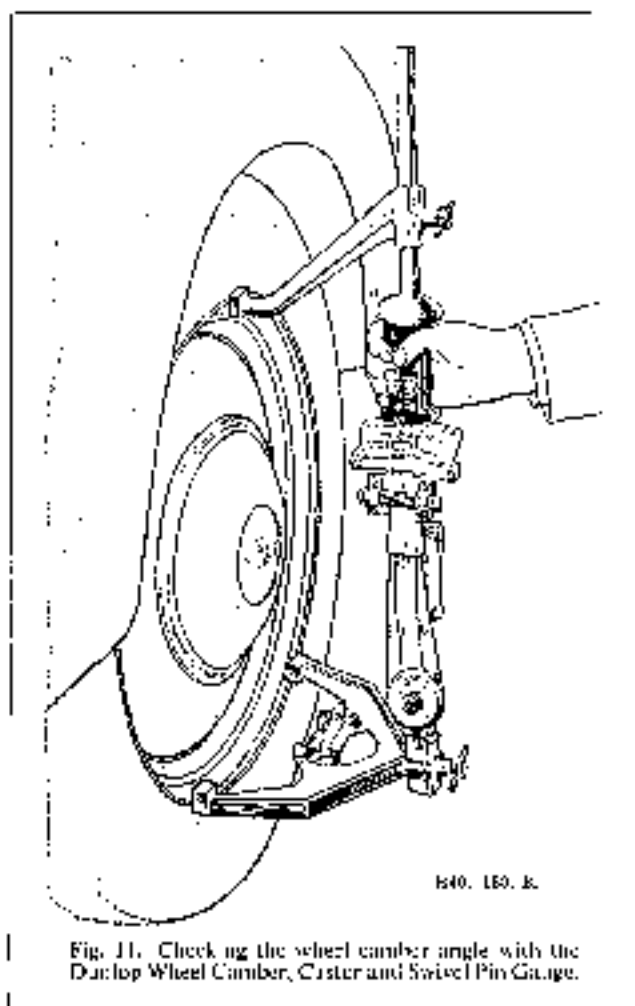

640. 150. B.

Fig. 11. Checking the wheel camber angle with the Dunlop Wheel Camber, Castor and Swivel Pin Gauge.

tained from the Dunlop Rubber Co. Ltd., Fort Dunlop, Erdington, Birmingham.







# STEERING

## GENERAL DATA

Type of Gear	Cam and Lever	Diameter of Steering Wheel	17-in. (43.18 cm.)
Steering Gear Ratio (Saloon)	14 to 1	Turning Circle (Cars)	37-ft. (11.278 m.)
Steering Gear Ratio (Sports)	12 to 1	Turning Circle (Commercial)	38-ft. (11.582 m.)
Bearings	Ball Race and Felt Bush	Track Toe-in	$\frac{1}{4}$ - $\frac{1}{2}$ in. (1.5875-3.175 mm.)
Adjustment	Screw & Packwood Shims	Steering Connections	Austin Ball Type

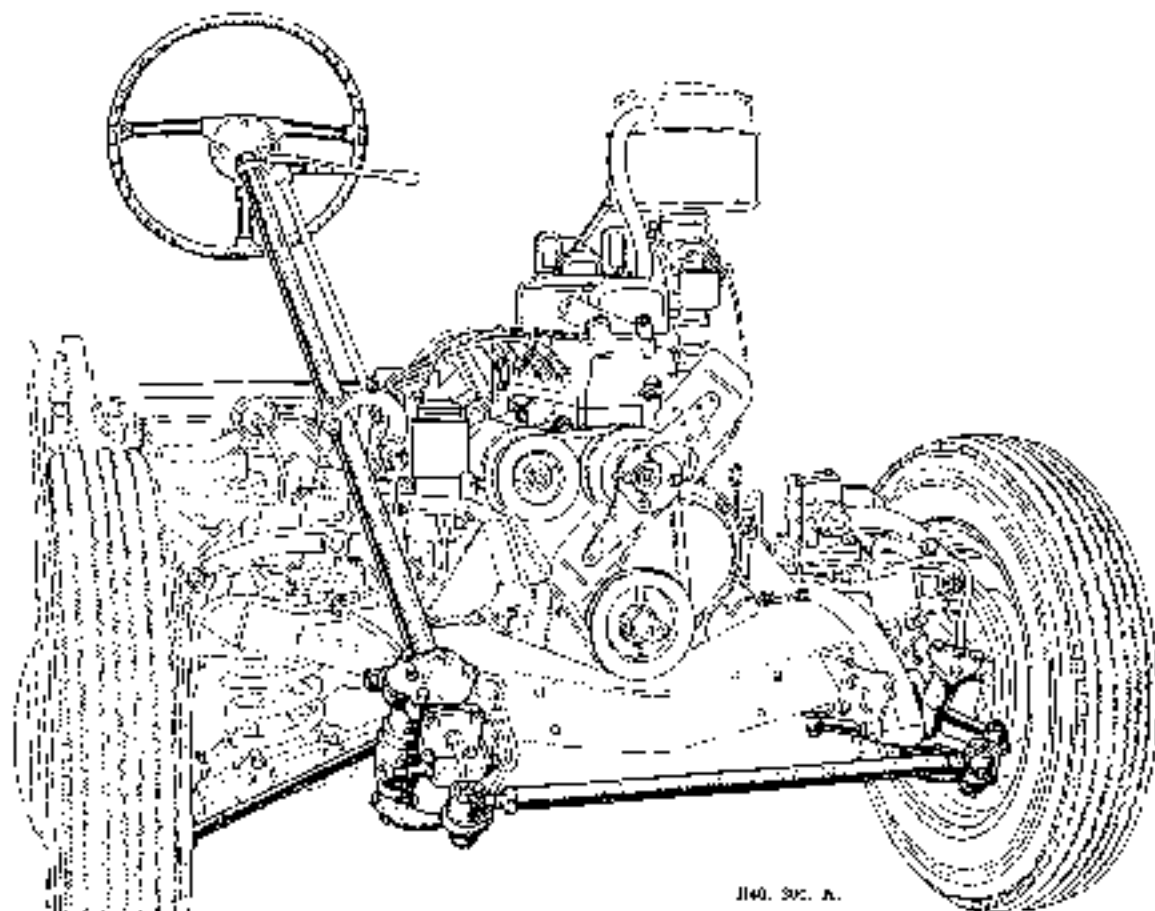

Fig. 1 A general view of the steering linkage for a right-hand model. On left-hand steering model the positions of the steering arm and idler shaft are reversed.

### Description

The steering gear, of "B-shop" design, is a self-contained unit of extreme simplicity. The steering tube revolves a cam which in turn engages with a taper peg fitted to a rocker shaft. This assembly is enclosed in an oil-tight casing, which carries two ball bearings at either end of the cam. The bearings are designed to carry radial and thrust loads.

When the steering wheel is turned the tube revolves the cam, which in turn causes the taper peg to move

over a pre-determined arc, thus giving the rocker shaft its desired motion. Attached to the rocker shaft is a double lever which links up with the steering linkage.

The steering linkage is of the "three cross-tube" type, having a centre cross-tube connecting the steering gear double lever to the arm on the idler shaft. Two shorter cross-tubes, one on either side, connect the steering arms to the steering gear and idler levers respectively. These two shorter cross-tubes are more generally referred to as side tubes.

**Maintenance**

Lubrication of the oil nipples on the steering connections and swivel bearings is most important to maintain accurate steering.

Approximately every 500 miles, use the oil gun and recommended oil to charge the following points with lubricant:

- (a) Steering side and cross-tubes — 6 nipples.
- (b) Lower wishbone arm outer bearing — 2 nipples.
- (c) Swivel pin bushes — 4 nipples.
- (d) Steering idler — 1 oil filler plug.

The steering gear should be topped up with recommended oil to the top of the filler plug opening approximately every 5,000 miles.

**STEERING CONNECTIONS AND IDLER****Adjusting the Track**

The track is best checked by means of the Dunlop Optical Alignment Gauge No. 9, particulars of which can be obtained from the Dunlop Rubber Company Limited, Fort Dunlop, Edington, Birmingham.

The cross-tube is threaded right-hand at one end and left-hand at the other, so that the track adjustment can be made by simply rotating the tube in the required direction after releasing the locknuts. On some models the adjustment is secured by clamps and pinch bolts. Under no circumstances should the setting of those side-tubes that are adjustable, be disturbed for tracking purposes except after a dismantling of the steering link-

ages. They should then be reset to  $11\frac{3}{16}$  in. measured between the ball pins. Always re-tighten the locknuts at each end of the cross-tube after an adjustment has been made.

**Side and Cross-Tubes**

The side and cross-tubes are held in position by a castellated nut and split pin at each end. On later models a washer is fitted beneath the castellated nut. It is essential that this washer be replaced on reassembly, otherwise the nut, when tightened, will be screwed too far down the thread to enable the split pin to lock the nut in position.

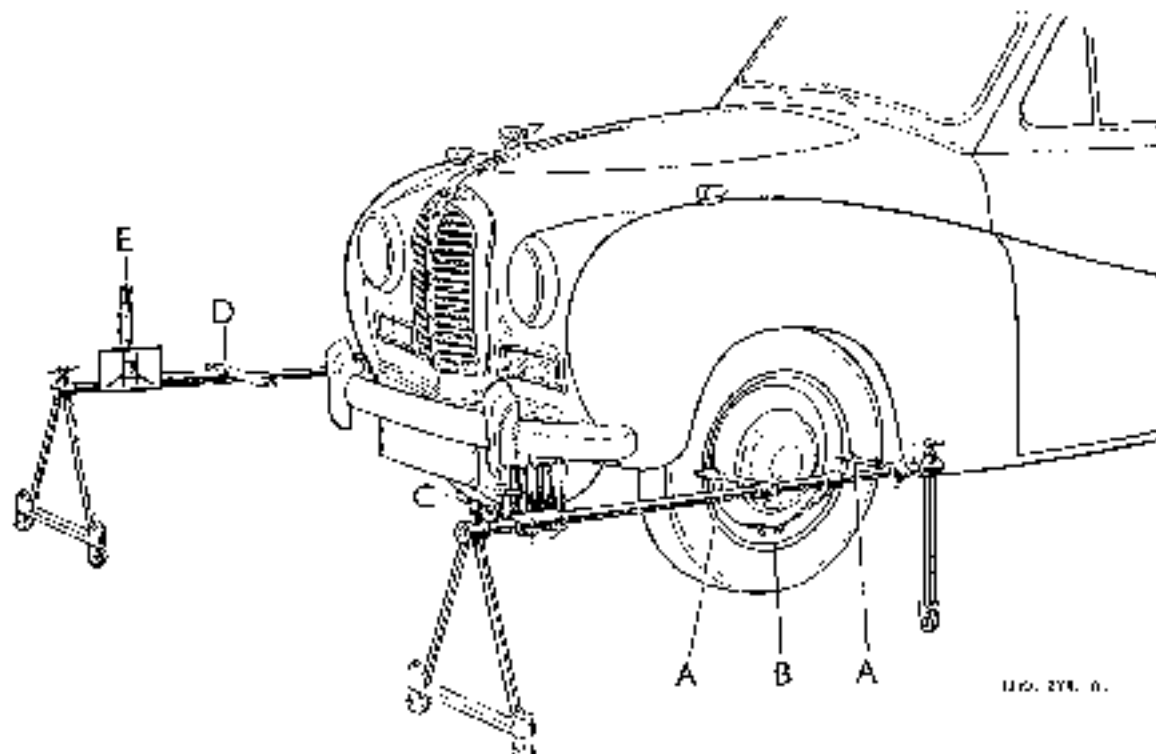

Fig. 2. Checking the wheel track with the Dunlop Optical Alignment Gauge No. 9. A, Wheel pointer; B, Attachment hook; C, Mirror; D, Calibrated scale; E, View box.

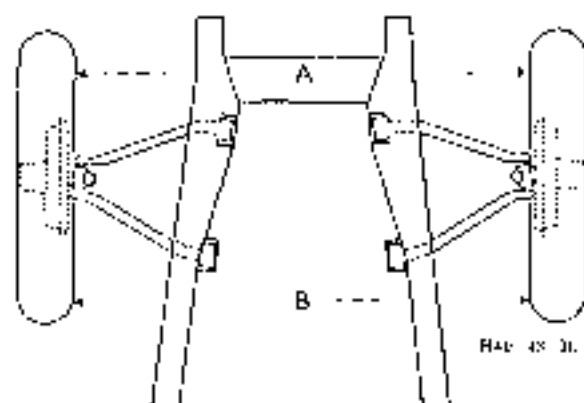

Fig. 4. The nut should be adjusted so that A is  $\frac{1}{4}$  to  $\frac{1}{2}$  inch less than B.

To remove the tubes, withdraw the split pin and release the nut at each end of the tube and then carefully tap the tubes clear of the levers to which they are attached. When removing one of the connections from either end of the steering gear double lever, always support the lever to prevent any shock from being transmitted to the steering gear where damage may be caused.

#### Tube Connections

Some steering side and cross-tubes are equipped with the Austin patent ball and socket connections which are screwed into the ends of the tubes and can be adjusted to take up wear. These connections consist of a threaded and castellated lower socket screwed into position and locked by a split-pin. The body of the tube-end has four split-pin holes drilled, vernier-pattern, at a different pitch from the castellations in the socket, thus permitting

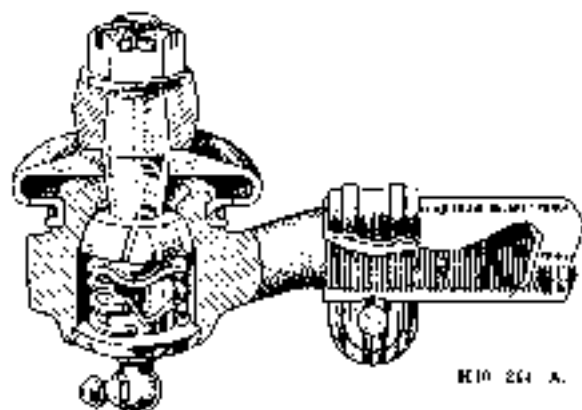

Fig. 5. Illustrating the self-adjusting type ball and socket connection.

a very fine adjustment. Adjustments should be made and checked regularly, otherwise undue slackness will cause a deformation of the ball pin thereby making further adjustment impossible.

To make an adjustment, remove the split pin, lightly screw it back to the first alignment of the split pin hole and castellation. The ball should then be able to move freely in the socket.

Always ensure that the rubber boot fits snugly in the groove provided for it in the tube end.

An alternative type of connection is employed on some models. This type is self-adjusting and requires no attention other than lubrication at the prescribed intervals.

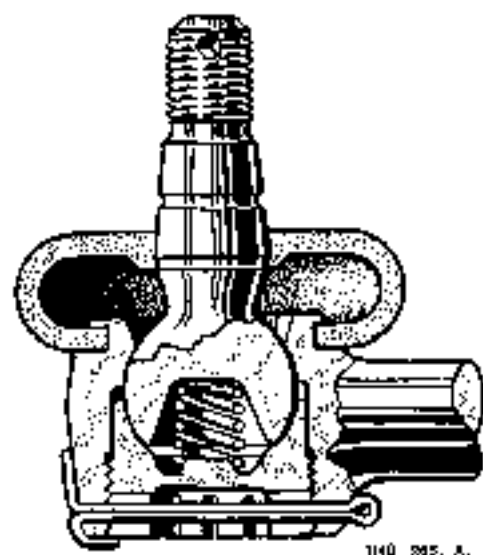

Fig. 5. Showing the adjustable type of the Austin patented ball and socket connection.

#### Removing the Double Levers

These are held to the steering gear rocker shaft and to the idler shaft respectively by a nut and split pin. With the removal of the nut and split pin, the double levers can be withdrawn from their splined shafts by using an extractor. See Fig. 11. Never attempt to lever or hammer the steering gear double lever from the rocker shaft, otherwise serious damage to the steering gear may result.

#### Removing the Idler

With the side and cross-tubes disconnected the idler can be detached from the chassis. It is secured by three bolts, inserted from the inside of the dumb-iron and terminating in the three lapped holes in the idler flange. Support the idler with one hand and unscrew the setscrews until their threads are clear of the holes, when the idler can be detached.

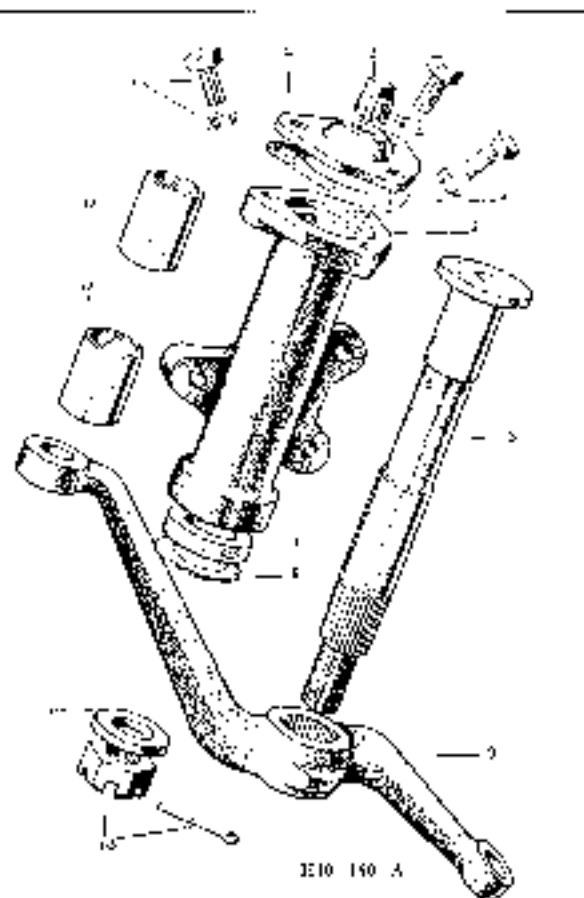

E10 140 A

Fig. 6. Steering idler parts explained

- |                          |                        |
|--------------------------|------------------------|
| 1. Cap setpin and washer | 8. Washer              |
| 2. Idler cap             | 9. Double lever        |
| 3. O.I. plug             | 10. Casted nut and pin |
| 4. Flat washer           | 11. Washer             |
| 5. Idler body            | 12. Lower bush bearing |
| 6. Idler shaft           | 13. Upper bush bearing |
| 7. Cork seal             |                        |

### Dismantling and Assembling the Idler

The idler top cap is secured to the body by three setpins and has a joint washer inserted between cap and body. Lubrication is effected by removing the oil plug in the cap and injecting oil into the body.

Internally 'the body' has a recess in the head and a plain bore right through. Two phosphor bronze bush bearings, with internal oil grooves, are pressed into position, one at the top and the other at the bottom of the body.

At the lower end of the body a cork seal butts up to the lower bearing bush and is retained in position by a steel washer, which in turn, is secured by the bore of the body being 'peened' over. By removing this burr with the aid of a hand scraper, the washer and cork seal can be extracted.

The idler shaft can be removed by hand once the body cap has been released. The flange of the idler shaft locates in the recess within the body head and the two highly finished portions of the shaft rotate within the

phosphor bronze bushes. At its lower end the shaft incorporates a spline to take the double lever and a portion of screw thread to take the lever securing nut. The idler shaft is drilled for passing lubrication to the bearing bushes.

No adjustment is necessary for this type of idler.

### Refitting the Idler

The refitting of the idler is generally a reversal of the removal procedure, but care should be taken to ensure that it is secured firmly against the frame by means of the three bolts with spring washers beneath their heads.

### Refitting the Double Levers

There is a locating mark in the double lever and a corresponding mark in the end of the steering gear rocker shaft. When refitting the double lever make sure that these marks coincide. Press the lever on to the splined shaft and secure it with the castellated nut, plain washer and split pin.

To check for the correct fitting of the lever, ensure that there is a distance of approximately 3-ins. between the underside of the frame side member and the upper machined face of the rear arm of the lever.

Press the lever on to the splined shaft and secure

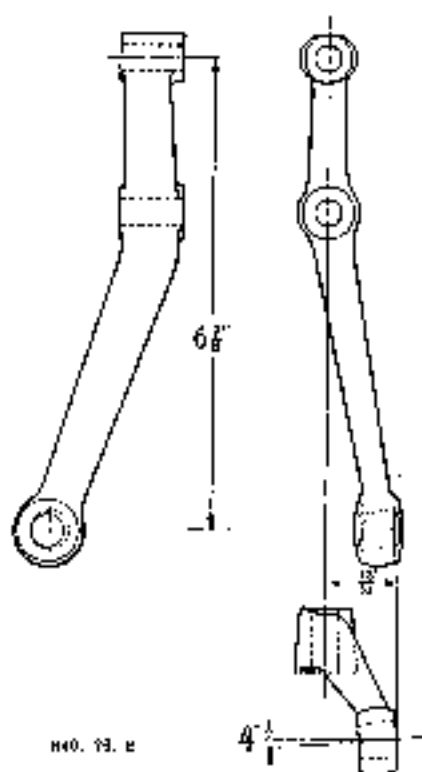

Fig. 7. Checking the alignment of a swivel arm (method 2)

U with the slotted nut, pin washer and split pin. Note that location marks are not necessary for this lever and shaft, but the clearance between the underside of the frame member and the rear machined face of the lever should be the same as for the lever fitted to the steering box shaft.

The wheels must be in the straight-ahead position while these two levers are being fitted.

#### Refitting the Side and Cross-Tubes

First connect the two side tubes to their respective steering arms and levers. Fit the cross-tube and ensure that both the side and cross-tube securing nuts are tight and split pinned.

#### Swivel Arms

The swivel arms connecting the swivel axles to the steering side-tubes may be checked for misalignment in the following way:—

(1) Place a rule along the brake back-plate so that it projects alongside the arm. The distance between the centre of the ball pin seating hole and the rule should be  $\frac{3}{8}$ -in. plus or minus  $\frac{1}{16}$ -in.

(2) Place a straight-edge across the centre of the ball holes used to secure the arm to the swivel axle. The distance between the straight-edge and the lower face of the arm machined face against which the ball pin nut fits—should be  $\frac{3}{16}$ -in. plus or minus  $\frac{1}{16}$ -in. (See Fig. 7.)

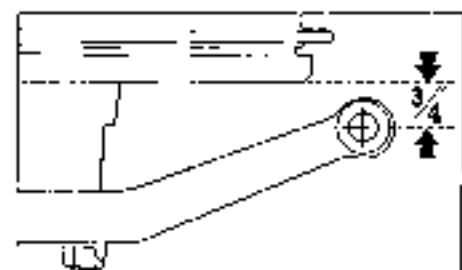

400.77.3

Fig. 8. Checking a swivel arm for misalignment (method 1)

## STEERING GEAR

#### Removing the Steering Gear

To remove the steering gear and column complete from the car, first remove the upper portion of the direction indicator control tube from within the steering column. Release the three grub screws which pass through the steering hub to secure the horn quadrant. At the steering box end of the column, the horn and indicator electrical cables should be disconnected at the nearest snap connections. The horn quadrant and short stator tube may then be withdrawn complete with cables.

It will be noticed that the short tube has a number of indentations on its outer diameter, thus forming lugs internally, which locate in the slot of the long tube remaining within the steering column.

Finally remove the locknut retaining the steering wheel in position. With a sharp jerk upwards the wheel may be freed from the splines and so removed from the column.

The gear change lever and rod are secured to the steering column by means of a clamp bracket, therefore the gear change must be released from the steering column. This operation simply entails the removal of the two Allen screws from the bracket.

Holding the steering column in place within the body there is a "U" bracket which is secured to the underside of the fascia panel. To dismantle this bracket, release the two setpins and remove the "U" bracket complete with its packing.

Next jack up the car at its front end and remove the bumper and apron, two operations that have been detailed under the Bodywork section of this manual. (In the case of the Sports and Commercials, it is only necessary to remove the front number plate.)

Remove the double lever from the rocker shaft, as previously described. Finally disengage the steering box from its mounting by removing the single nut and bolt and relative washers, and the two rear setpins and spring washers, all of which pass through the chassis side members, to the steering supporting bracket.

The steering gear complete with column may now be withdrawn from the car by an outward movement and a slight twisting to avoid the bodywork.

When replacing the steering, reverse the removal procedure but do not tighten the box securing setpins and single bolt, until the column has been secured within the driving position.

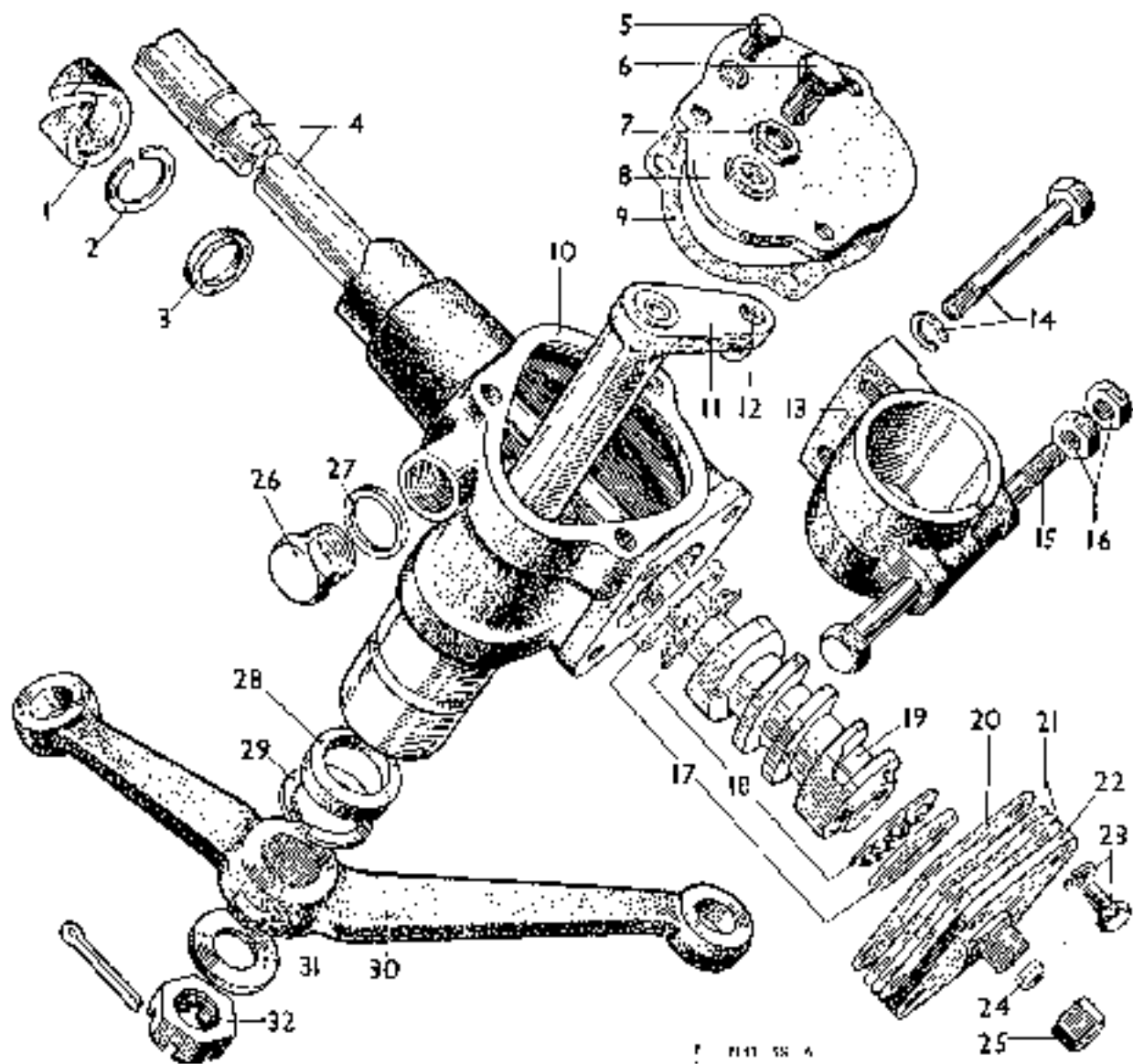

FIG. 9

Fig. 9. Components of the steering box.

- |                                  |                               |                                   |
|----------------------------------|-------------------------------|-----------------------------------|
| 1. felt washer.                  | 12. Peg for rocker arm.       | 25. Spring and washer.            |
| 2. Cotter pin.                   | 13. Steering gear bracket.    | 26. Friction tube gland washer.   |
| 3. Cork washer.                  | 14. Spring and washer.        | 27. Frills for tube steering nut. |
| 4. Steering inner column.        | 15. Brass clamp bolt.         | 28. Filler plug.                  |
| 5. Top cover shell.              | 16. Clamp bolt locknuts.      | 29. Filler plug washer.           |
| 6. Rocker shaft adjusting screw. | 17. Ball cups for bearings.   | 30. Case washer.                  |
| 7. Adjusting screw locknut.      | 18. Ball and cage assembly.   | 31. Retaining disc.               |
| 8. Tire cover.                   | 19. Cam.                      | 32. Double case.                  |
| 9. Nut washer.                   | 20. Taper washer.             |                                   |
| 10. Steering gear housing.       | 21. Heating adjustment studs. |                                   |
| 11. Rocker shaft arm.            | 22. End cover.                |                                   |



**Disassembling**

The top cover plate should be removed after extracting the three securing screws.

Turn the steering gear over and suitably support the top face leaving the rocker shaft free to be lightly tapped out using a soft metal drift. The following peg is a drive fit in the rocker and need not be removed unless showing an appreciable amount of wear.

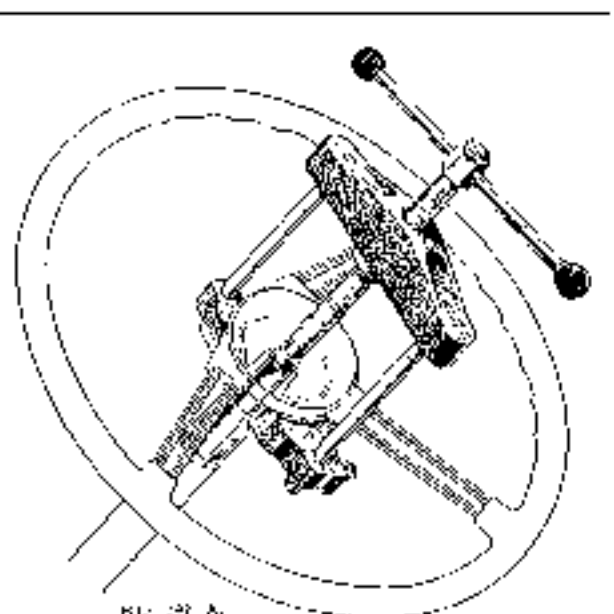

18G 70 A

Fig. 10—Using Service Tool 18G 70 to withdraw a tight steering wheel.

Remove the four setpins securing the end cover plate in position, and release the end cover. The complete unit should now be up-ended with the steering box uppermost. By bumping the end of the inner shaft on a block of wood, placed on the floor, the worm with its two ball bearings will be displaced. The complete inner column can then be withdrawn from the casing through the open end of the steering box.

For extracting the felt bush at the top of the column, use a piece of strong hooked wire, the hook pulling on the under face of the bush. The fitting of a new bush is simple; smear the felt with heavy oil and press into place.

Adjusting shims should be fitted behind the end cover so that there is no end play on the column, but at the same time they should not be pre-loaded, otherwise damage to the ball races may ensue.

The rocker shaft may now be dropped into position, ensuring that it is a good fit in its housing and that the oil seal at the lower end of the transom is making good contact.

**Adjusting the Gear**

The adjuster in the cover plate should be slackened by releasing the locknut and unscrewing the screw a few turns. The cover plate can then be fitted making sure an oil-tight joint is obtained. The adjuster should be screwed down until there is no free movement in the straight ahead position of the gear and the adjustment secured by the locknut.

Final adjustment should be made once the gear has been reassembled to the chassis. It should be noted that as wear in use is normally greater in the straight ahead position than on lock, provision is made for this in the design of the cam, and it will be found that there is a slight end play towards each lock. It is essential, therefore, that adjustment should be made in the straight ahead position to avoid the possibility of tightness.

The steering gear should be filled with recommended gear oil via the filler plug situated at the rear right-hand side of the steering box and then a final test made to ensure that the movement is free from lock to lock.

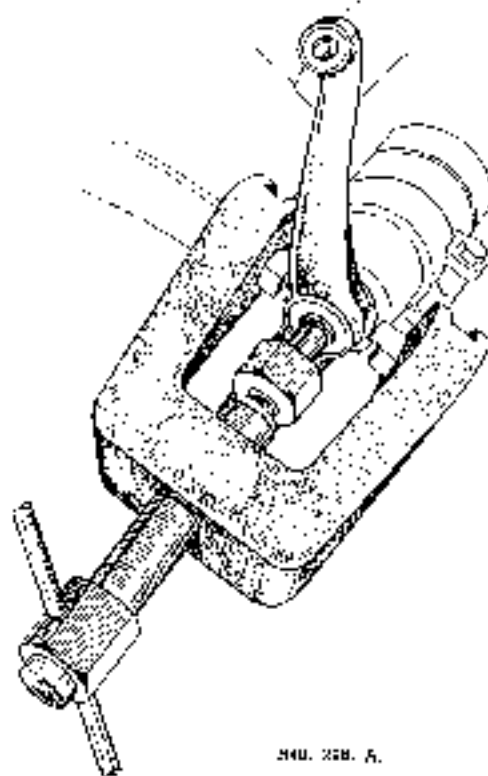

18G 75 A

Fig. 11—Using Service Tool 18G 75 to remove a double lever.

## STEERING FAULTS

If steering faults are not attributed to adjustment of the gear, they may fall into one of the following categories.

### Last Motion

The amount of last motion reaches its maximum at either lock, but this is not normally felt at the steering wheel, since the geometry of the steering always tends to return the steering gear to the straight ahead position.

Excessive last motion in the steering gear will result in unsteady steering, knocks and backlash all of which can be felt at the steering wheel. This defect may be attributed to loose steering connections throughout the linkage.

### Tight Steering

If the steering is tight, disconnect the steering ties and test the feel of the steering wheel. Stiffness may be due to the steering column being pulled out of line and this can be verified by loosening the column supporting bracket under the fascia and allowing the column to find its free position. Should the steering still be stiff

check whether this is so in all positions. If so, the cause may be:

- (a) The direction indicator tube is fouling the column.
- (b) The felt bush at the top of the steering column is too tight.
- (c) The steering tube is bent.

To ascertain whether the direction indicator tube is fouling the column, withdraw the indicator tube as previously described. Turn the steering wheel and if the stiffness has disappeared, it will probably be found that the indicator tube is bent, thus requiring a replacement.

Should the steering still be stiff with the indicator tube free, withdraw the steering wheel and check the tightness of the felt bush and renew, if necessary.

If the bush is free but the steering remains tight, remove the bush and check whether the steering column pulls heavily to one side. The inner column is fairly flexible and slight pulling to one side has little or no effect on the feel of the gear, but it may be that the column is bent thus giving no alternative but to renew the column.

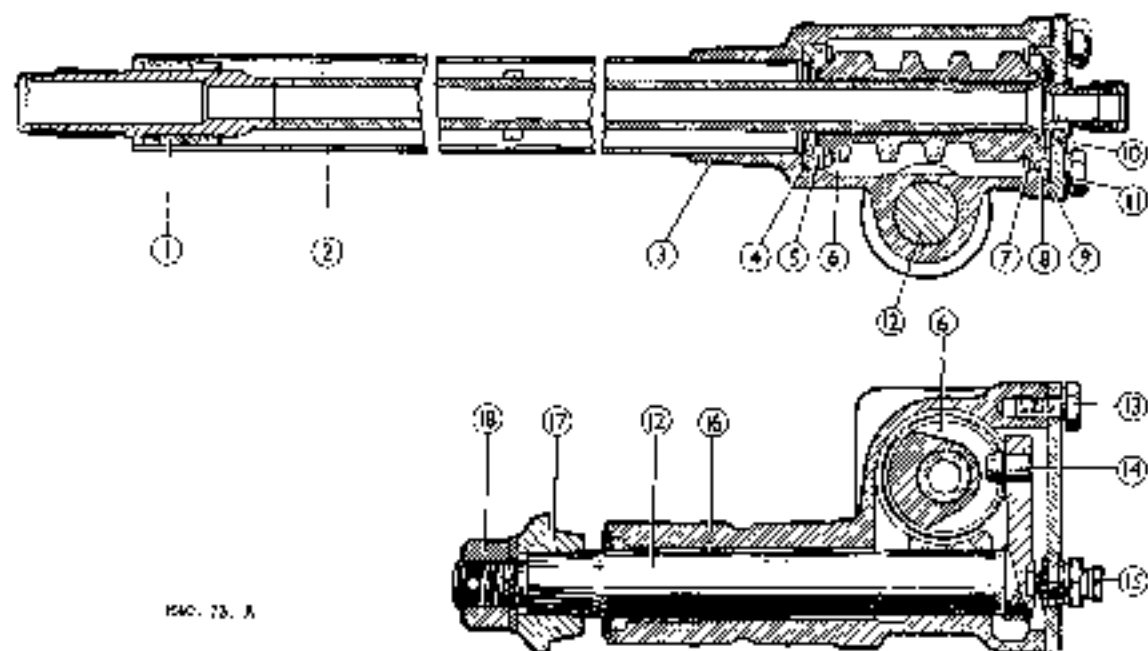

1940. 75. A

Fig. 12. Section views of the steering gear.

- |                           |                           |                                   |
|---------------------------|---------------------------|-----------------------------------|
| 1. Felt bush.             | 2. Inlet cage—inner.      | 15. Top cover screw.              |
| 2. Steering inner column. | 3. Ball cup for bearing.  | 16. Rocker adjuster.              |
| 3. Steering gear housing. | 4. Joint washer and shim. | 17. Rocker shaft adjusting screw. |
| 4. Ball cup for bearing.  | 5. Ball cage—inner.       | 18. Rocker shaft bearing.         |
| 5. Ball cage—inner.       | 6. Shaft.                 | 19. Double lever.                 |
| 6. Shaft.                 |                           | 20. Sector pin.                   |
|                           |                           | 21. Rocker shaft.                 |

**Loose Steering**

Loose steering is invariably attributed to end play of the inner column, which can be rectified by the removal of shims located behind the steering box end cover plate, in a manner already described.

To check for this end float, disconnect the side and

cross-tubes from the double lever and turn the steering partly to the right or left lock. Then with the steering wheel held to prevent it from turning, endeavour to turn the double lever. Should the steering wheel have a tendency to lift, it may be assumed that there is end float of the gear.







# REAR AXLE

## GENERAL DATA

Type	...	...	...	3 floating
Oil Capacity	...	2½ pints; 2 ⅔ U.S. pints	...	1.28 litres
Final Drive	...	...	...	Spiral Bevel
Crown Wheel Teeth:	Saloon	...	...	47
	Sports	...	...	46
	Commercials	...	...	43
Bevel Pinion Teeth	...	...	...	7
Ratio:	Saloon	...	...	5.28:1
	Sports	...	...	5.14:1
	Commercials	...	...	6.14:1
Crown Wheel to Pinion Backlash	...	...	...	005-.006-in. (.127-.203 mm)

## BEARINGS

Pinion Front:	...	...	...	Timken or SKF
Make	...	...	...	Timken or SKF

## Pinion Front (cont.):

Type	...	...	...	Taper Roller
Size	...	...	...	1 × 2½ × ½ × 1½-in. (25.4 × 63.5 × 15.8 × 20.6 mm.)

## Pinion Rear:

Make	...	...	...	Timken or SKF
Type	...	...	...	Taper Roller
Size	...	...	...	1.75 × 2.8994 × 0.9375 × 1.1811-in. (44.78 × 73.67 × 23.81 × 29.99)

## Differential:

Make	...	...	...	R. and M. I.D.T. 40 (5 1007)
Type	...	...	...	Double Purpose Ball Journal (light)
Size	...	...	...	40 × 80 × 18 mm.

## Hub:

Make	...	...	...	R. and M. I.D.T. 40
Type	...	...	...	Ball Journal Double Row (light)
Size	...	...	...	40 × 80 × 23 mm.

## MAINTENANCE

### Axle Shaft To Remove and Replace

Check all wheels not being operated upon.

Jack up the car and lower the spring on to blocks as close as possible to the axle.

Remove the wheel.

Take out the drum locating screw, using a screw-driver. The drum can be tapped off the hub and brake linings, provided the handbrake is released and the brake shoes are not adjusted so closely as to bind on to the drum.

Should the brake linings hold the drum when the handbrake is released, it will be necessary to slacken the brake shoe adjuster a few notches.

Remove the axle (differential) shaft retaining screw and draw out the axle shaft by gripping the flange outside the hub. It should slide easily, but if it is tight on the studs, it may need gently prising with a screwdriver inserted between the flange and the hub. Should the paper washer be damaged it must be renewed when reassembling.

Replacement is a reversal of the above operation.

### Hubs To Withdraw and Replace

Remove the wheel and axle shaft as described, when the hub retaining nut will be accessible. This nut is locked in position by a keyed washer which is hammered down on to one of the flats of the nut. Knock back the washer and remove the nut with a well-fitting spanner such as Service Tool No. 18G 23.

The lockwasher can be removed by hand tilting it so that the key disengages with the slot in the threaded portion of the axle case.

To use the extractor GT 40 on the rear hub the adapter will be needed. It will be seen that the adapter fits into the end of the axle tube and provides a stop for the extractor bolt.

The extractor is fitted over the wheel studs and held in position by two wheel nuts screwed well down. By screwing up the central bolt of the extractor, using either a spanner or a tommy bar, the hub and double-row ball-bearing, together with washers and oil seal, will be withdrawn. Fig. 3 shows the assembly order.

The bearing can be tapped out of the hub with the aid of a drift.

### To Reassemble

The hub bearing is not adjustable and is replaced in one operation.

It is essential that the face of the outer race protrudes .001-.004-in. (.0254-.1016 mm.) beyond the face of the hub plus paper washer when the bearing is pressed into place. This ensures that the bearing is definitely gripped between the abutment shoulder in the hub and the flange of the differential shaft.

The hub is then mounted on the axle tube, followed by the lockwasher (which has a tongue to register with the groove or hole) and finally the securing nut.

Tighten up the nut until the hub is fully home, and then secure by tapping down the lockwasher on one of the flats of the nut.

Replace the axle shaft, carefully finding the spline engagement with the differential unit and ensuring that the flange and washer are threaded over the hub studs in the position in which the ten small holes of the flange

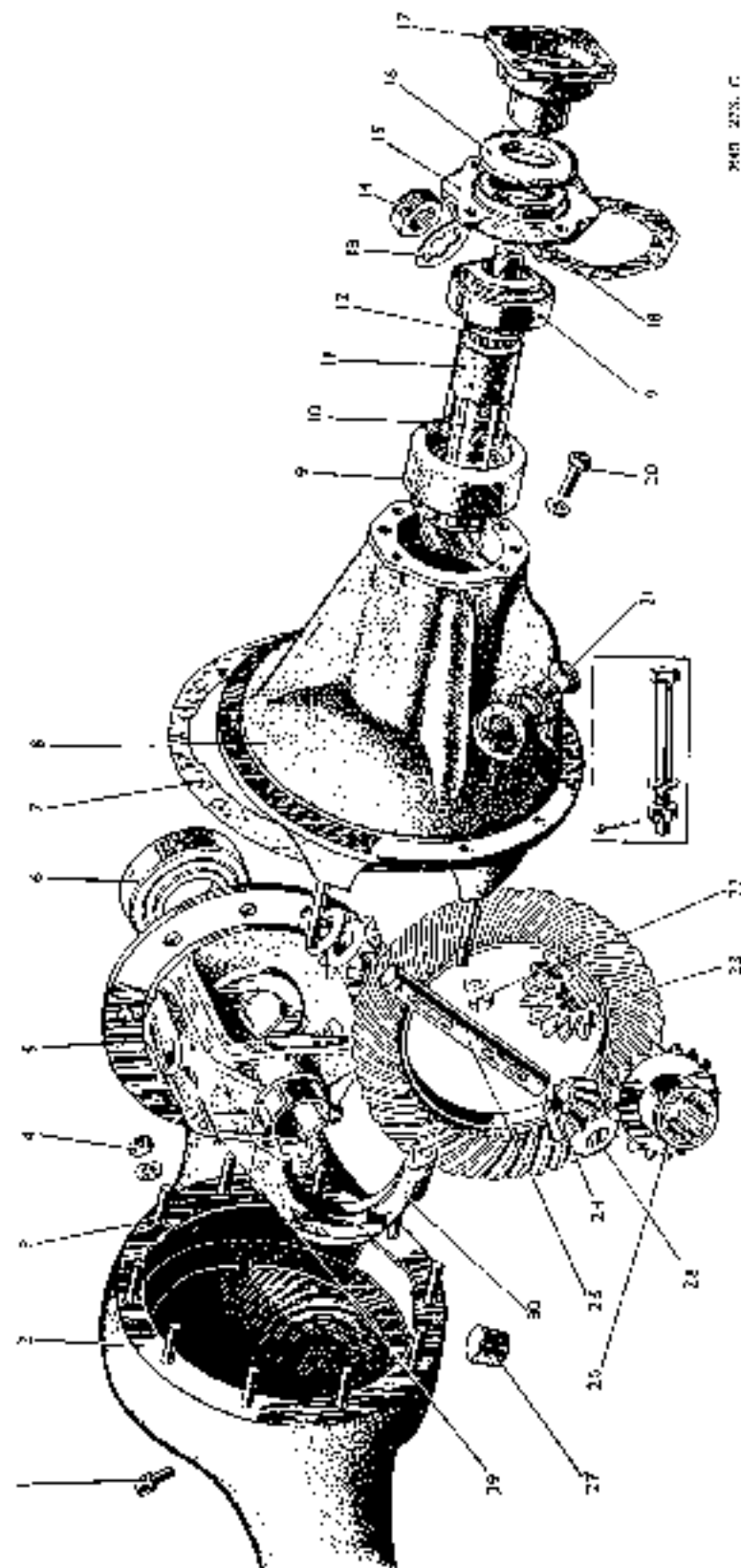

2400 2733 C

Fig. 1. An exploded view of the differential.

- |                        |                               |                                 |                                |
|------------------------|-------------------------------|---------------------------------|--------------------------------|
| 1. Axle bracket.       | 8. Gear carrier.              | 16. Dust cover.                 | 23. Crown wheel.               |
| 2. Axle base.          | 9. Bevel pinion rear bearing. | 17. Pinion flange.              | 24. Differential pinion shaft. |
| 3. Gear carrier stud.  | 10. Bevel pinion.             | 18. Joint washer.               | 25. Differential wheel.        |
| 4. Gear carrier nut.   | 11. Pinion sleeve.            | 19. Bevel pinion front bearing. | 26. Differential wheel.        |
| 5. Differential case.  | 12. Bearing adjusting shim.   | 20. End cover by fr.            | 27. Axle shaft plug.           |
| 6. Crown wheel casing. | 13. Bevel pinion lock washer. | 21. Oil filler plug.            | 28. Pinion thrust washer.      |
| 7. Joint washer.       | 14. Bevel pinion nut.         | 22. Crown wheel bearing cap.    | 29. Pinion shaft securing pin. |
|                        | 15. End cover.                | nut                             | 30. Crown wheel bearing cap.   |

Note: Shows the through bolt for securing the crown wheel bearing cap (16) when the gear carrier (8) is made of cast aluminum.

Note: The bevel pinion can only be driven out of the carrier towards the crown wheel



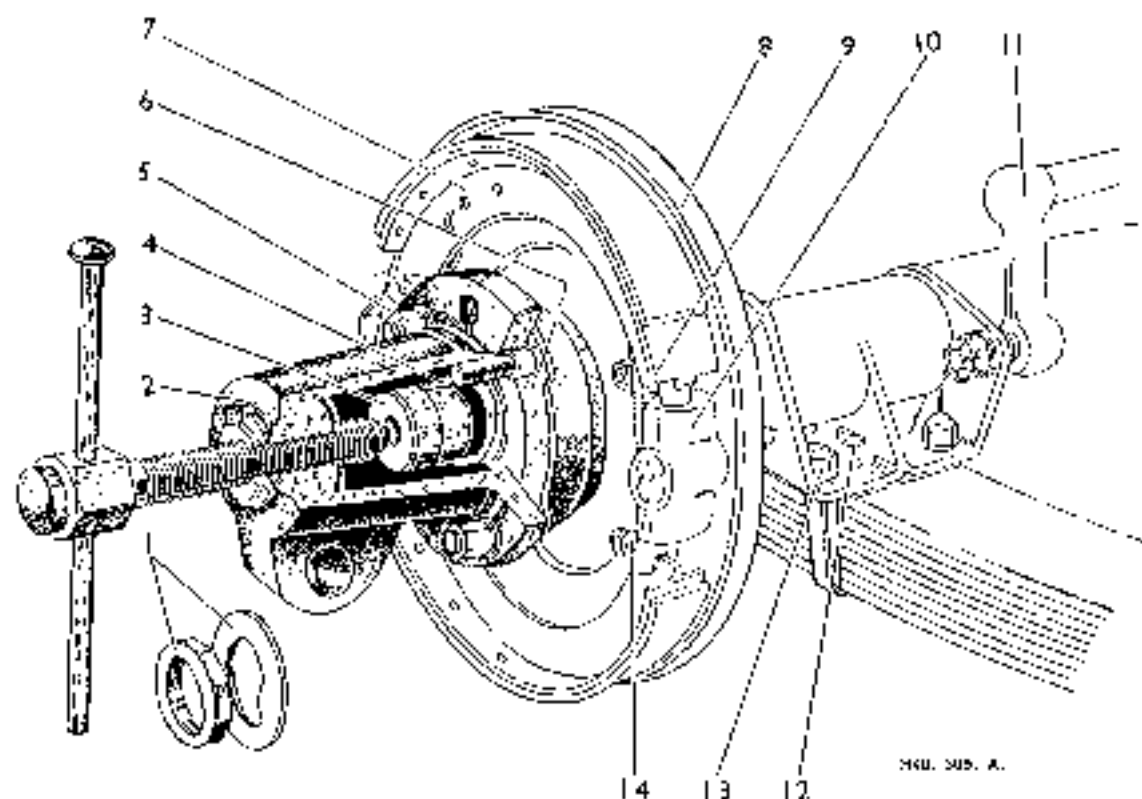

Fig. 2. Using Service Tool 18G 10 to extract a rear hub.

- |                           |                             |                              |
|---------------------------|-----------------------------|------------------------------|
| 1. Hub locknut and washer | 6. Hub                      | 11. Shock absorber arm       |
| 2. Hub extractor          | 7. Brake shoe               | 12. Rear spring centre bolt  |
| 3. Extractor adaptor      | 8. Brake back plate         | 13. Spring clip securing nut |
| 4. Axle tube              | 9. Brake shoe return spring | 14. Back plate securing nut  |
| 5. Wheel stud and nut     | 10. Brake shoe adjuster     |                              |

and hub coincide. Then refit the brake drum taking the same precaution regarding the small hole, and ensuring that the drum is well home when inserting the screw. Temporary use of the wheel nuts will assist.

Replace the wheel and finally tighten the nuts.

During reassembly the hubs should be packed with fresh grease even though they receive some lubricant from the axle during normal running.

#### Pinion To Renew the Oil Seal

This oil seal can be renewed with the axle in position.

Knock back the lockwashers and take out the four bolts of the propeller shaft flange to axle pinion flange.

Remove the large nut at the centre of the pinion flange after knocking back the lockwasher and then withdraw the flange itself. A flange extractor should be used, but it may be possible to tap the flange off the splined pinion shaft.

Remove the four setpins from the pinion end cover

after knocking back the tub washers, when the end cover can be withdrawn.

The oil seal is pressed into this end cover, but can be removed with a punch. The end cover is of aluminium and care must be taken to prevent damage. Never remove an oil seal from the end cover unless it is intended to renew it, as it is invariably distorted on removal.

The new oil seal must be carefully pressed home with the edge of the rubber or leather sealing ring facing inwards.

Replace the end cover and paper washer and lock up the four setpins when thoroughly tightened. Replace the pinion flange, serrated washer, and nut. This nut must be fully tightened and finally locked in position by bending over the lip of the washer. Use new lockwashers when bolting up the propeller shaft.

#### Carrier To Withdraw

To renew the pinion bearings or to effect any servicing of the crown wheel and differential unit it is first necessary to withdraw the gear carrier.

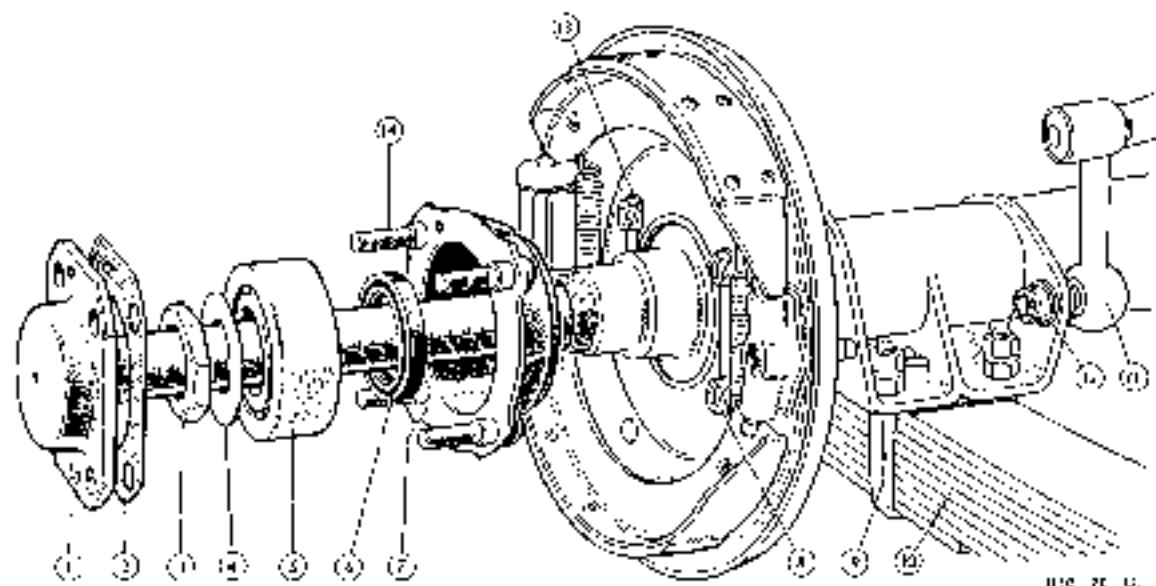

Fig. 3. Rear hub assembly exploded.

- |                       |                             |   |
|-----------------------|-----------------------------|---|
| 1. Axle shaft flange. | 6. Oil seal.                | 11. Shock absorber arm.                     |
| 2. Joint washer.      | 7. Hub casing.              | 12. Arm securing nut.                       |
| 3. Hub lock nut.      | 8. Back plate securing nut. | 13. Lockwasher for back plate securing nut. |
| 4. Hub lock washer.   | 9. Spring "U" bolt.         | 14. Wheel stud.                             |
| 5. Hub bearing.       | 10. Spring.                 |   |

The gear carrier unit can be withdrawn with the axle in position, although it is first necessary to remove the propeller shaft and then the axle shafts. For this latter operation the road wheels and brake drums must also be removed as already described under 'Axle shaft removal'.

Remove the gear carrier unit drain plug and run the oil into a suitable receptacle.

Then remove the nuts which hold the gear carrier to the axle case and lift out the carrier complete.

#### Pinion and Bearings—To Remove

It is strongly advocated that operators should make use of the special service tools that are available. This is particularly important where the bevel pinion bearings are concerned if damage is to be avoided to races and gear carrier. Tools mentioned are illustrated in section Q of this manual.

Remove the gear carrier assembly from the axle casing, as previously described in this section. Remove the differential bearing caps and lift out the differential unit from the carrier.

Using the wrench 18G 34 to hold the bevel pinion flange from turning, remove its securing nut and locking washer. The flange should now be withdrawn from the bevel pinion, using the extractor 18G 12. The oil seal and end cover should be removed by releasing four setpins.

Drive out the bevel pinion rearwards through the carrier, using a soft metal drift. The pinion will take

with it the inner race and roller of the rear bearing distance piece and shims, leaving the front bearing in the carrier. To remove the inner race and rollers of the rear bearing from the bevel pinion, use the extractor 18G 12. The inner race and rollers of the front bearing can be removed with fingers.

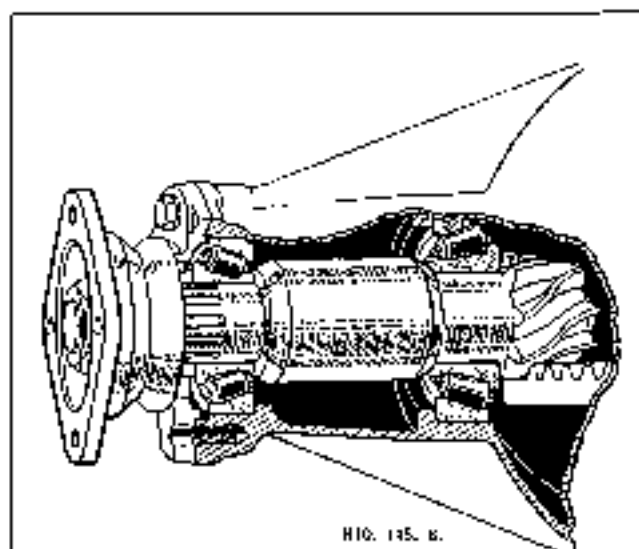

FIG. 145. B.

Fig. 4. The tapered roller bearings are subjected to a pre-load of 5 to 7 lbs, controlled by shims fitted between the pinion sleeve and the inner races of the bearings.

Secure the carrier to a bench and prepare to remove the rear outer race first, using Service Tool 186-82 (see Fig. 6). This tool comprises the following parts: A body, a centre screw with a tommy bar, a wing nut and locating cone. In addition, there are three adaptors, lettered A, B and C. Place the body of the tool (3), Fig. 5, over the studs so that the screw (5) is central in the carrier and fit the halves of the adaptor (B) inside the race and round the screw so that their flanges fit under the lower edge of the race (8).

Hold the tommy bar and screw up the cone to engage with the adaptors. Operate the wing nut and the outer race will be removed.

Now insert the screw (5) through the smaller aperture of the carrier and fit the halves of the adaptor (C). Remove the front race in a similar manner as employed for the rear race. (See Fig. 8.)

#### Pinion and Bearings- To Replace

To refit the rear outer race in the gear carrier, position the adaptor ring (A) in the smaller opening thus serving as a pilot for the body of the tool, see Fig. 7. Pass the screw (5) through this ring, place the rear outer race (8) over the cone (7) at the end of the screw (abut face innermost) and place the split adaptor (B) inside the race. Hold the tommy bar while screwing up the cone (7) to bring the adaptor and race into position. Then rotate the wing nut (2) until the race is firmly in place.

Remove the pilot (A) from the front end of the carrier and place the tool in position over the studs so

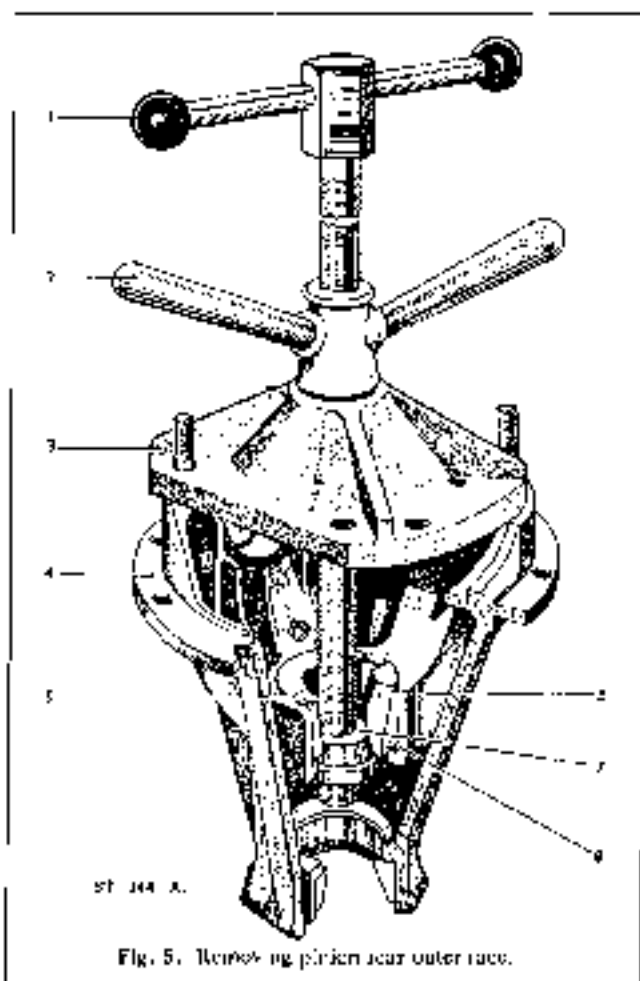

ST. 144. A.

Fig. 5. Removing pinion gear outer race.

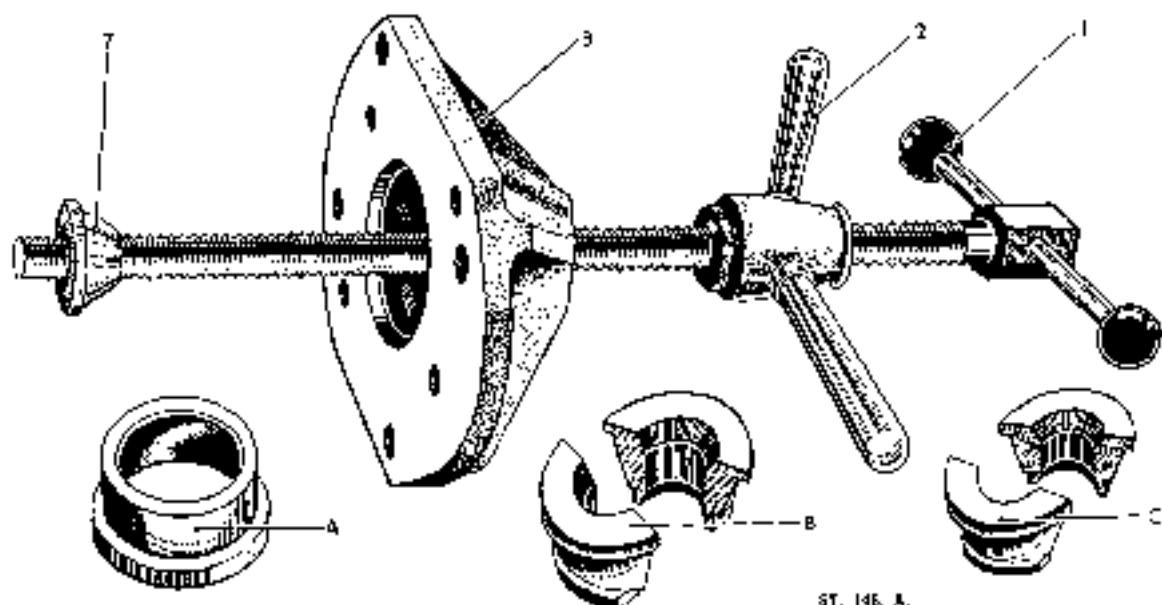

ST. 146. A.

Fig. 6. Service Tool 186-82, to remove and replace pinion outer races.

1. Tommy bar 2. Wing nut 3. Tool body 7. Cone. A. Adaptor ring. B. Split adaptor for removing and replacing rear outer race. C. Split adaptor for removing and replacing front outer race

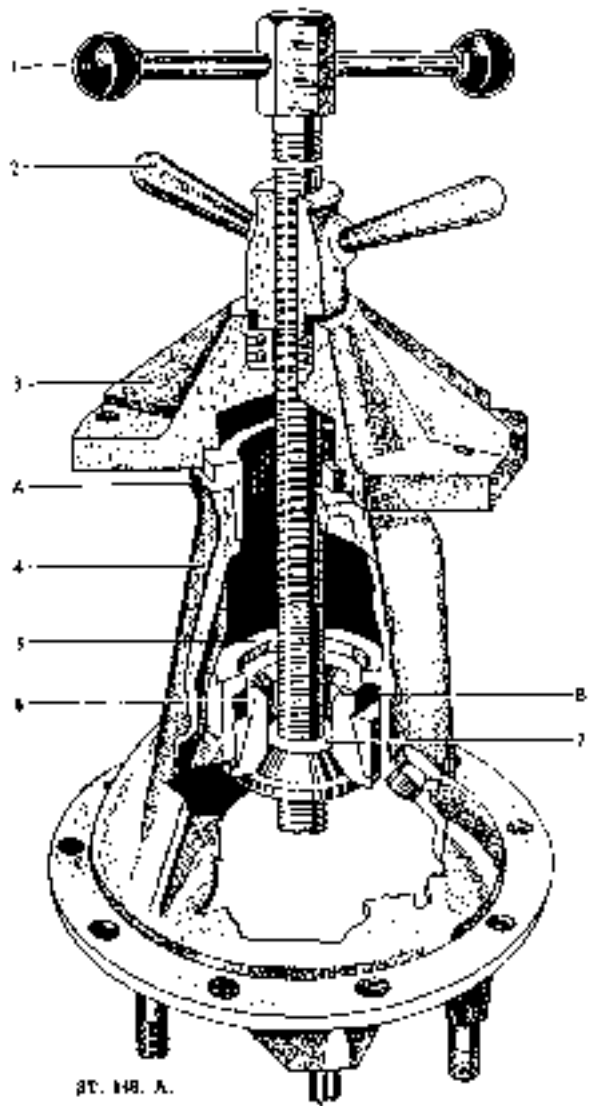

ST. 148. A.

Fig. 7. Replacing pinion rear outer race

that the screw is central in the carrier. Fig. 9. Now refit the front outer race, using adapter (C), in the same manner as that employed for the rear outer race.

With tool 18G 12 fit the rear bearing inner race and rollers on to the bevel pinion shaft. Slide the pinion bearing distance piece on to the shaft together with the estimated number of shims to give a pre-load of 5 to 7-in.-lbs. (.001 pre-load approximately equal to 1-in.-lb). The pinion thus assembled must be pushed into position from the rear and the front bearing inner race and rollers tapped on from the other end. Replace the oil seal, joint washer, end cover, bevel pinion flange (using drill 18G 1), serrated washer and nut. Lock the nut in position by bending the washer over.

A convenient method of checking this pre-loading is by mounting a 4-in. (10.16 cm.) diameter drum or pulley on the bevel pinion flange. Then, when a 3 lbs. (1.36 kg.)

weight is hung by a piece of cord from the circumference of the pulley, the pre-loading on the pinion bearings should be sufficient to prevent the pinion, and therefore the pulley, from turning. When a 3 1/2 lbs. (1.58 kg.) weight is used the pulley should move under the load. This gives the bearings a pre-load of approximately 5 to 7-in.-lbs. (.0575-.0806 mkg)

Refit the differential unit to the carrier, secure the bearing caps and place the complete assembly into the axle casing.

**Crown Wheel and Bearings To Remove**

To detach the crown wheel knock back the lock-washers and remove the eight bolts.

The ball thrust races should be a tight fit on each end of the differential case and if found to be loose a new case will be needed. The bearings should be tight enough to need an extractor for removal.

**Differential Wheels and Pinions—To Remove**

The differential case is of one piece construction which cannot be dismantled.

To release the differential wheels and pinions, tap out, from the left-hand side, the peg securing the pinion shaft. Extract the shaft and remove the wheels and pinions.

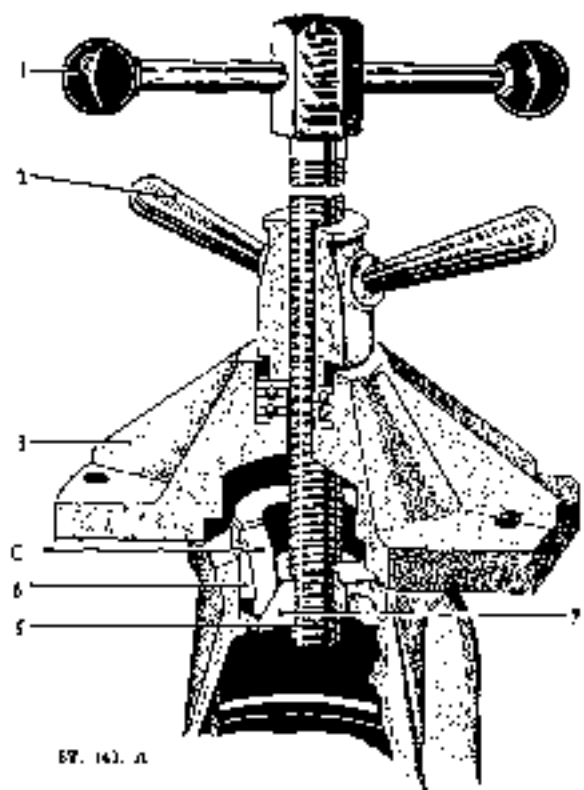

ST. 143. A.

Fig. 8. Removing pinion from outer race.

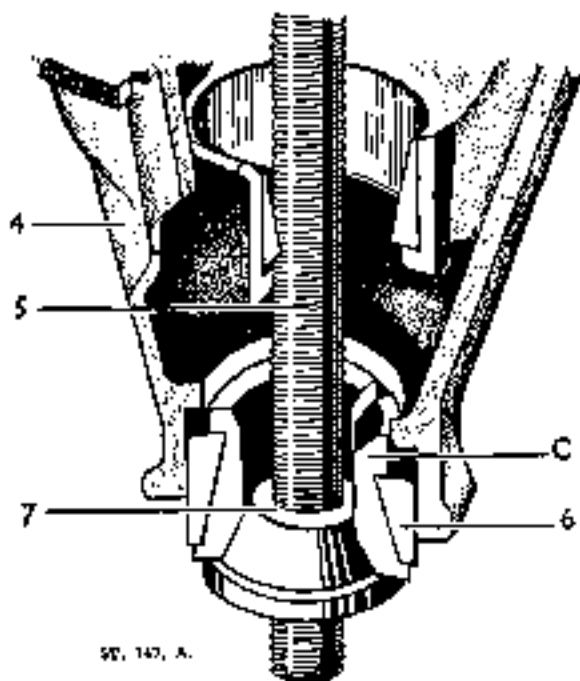

97, 147, A.

Fig. 9. Replacing pinion from outer race.

The unit is now fully dismantled and all parts should be checked for scoring and signs of wear.

Wash all parts in paraffin, and ensure that they are clean when reassembled.

#### Differential Wheels and Pinions To Replace

Replace the differential wheels in the case and place the pinions, together with their thrust washers, in position. Push home the pinion shaft and secure with the shaft retaining peg. The peg can only be fitted from the right-hand side of the case and, when in position, the rim of the hole must be sufficiently parted over to prevent the peg vibrating loose.

#### Crown Wheel and Bearings To Replace

Bolt the crown wheel in the differential case but do not turn over the lockwashers. If new races are necessary take particular care to ensure they are fitted correctly. The word "thrust" which is stamped on one side of the race must be on the outside.

At this stage the crown wheel should be checked for alignment. The crown wheel, differential case and bearings complete should be placed on a pair of vee blocks for this test and a dial indicator used. The crown wheel should be slowly rotated and measurements taken on the face of the wheel. The crown wheel must not be more than .002-in. (.0508 mm) out of true. Any greater irregularity must be corrected. First detach the crown wheel from the differential casing and examine for any slight particles of grit on the flange. When the

parts are thoroughly cleaned it is rare to find that the crown wheel does not run true. The pinion mesh will be automatically correct for depth.

Finally turn over the lockwashers for the crown wheel securing bolts.

#### Carrier—To Replace

With the bevel pinion in place in the gear carrier and the pinion bearings correctly adjusted for pre-load as described in an earlier paragraph, the crown wheel and differential unit can be refitted to the carrier.

Replace the differential unit complete into the carrier and secure the end caps with the four nuts and spring washers. On models fitted with an aluminium carrier, bolts are employed instead of studs. (See inset, Fig. 1.) The differential unit bearings should be a tight fit into their respective housings in the carrier, since in manufacture the machining tolerances of the bearing housings are adjusted to give a .002-in. (.0508 mm) pre-load on the bearings.

The backlash between the mesh of the pinion and crown wheel teeth should be between .005-.008-in. (.127-.2032 mm), and the correct figure for each set of gears will be found etched on the back of the crown wheel. Measure the backlash when the gears are secured in the carrier by using a dial gauge to register against the crown wheel teeth while the pinion is firmly held. If the backlash is found to be too great or too small, adjustment may be effected by moving the shim or shims, positioned between the differential case and the inner race of the differential bearings, from one side of the crown wheel to the other as required.

The differential carrier can now be refitted into the axle case and secured by replacing the nuts. Use a new paper joint washer.

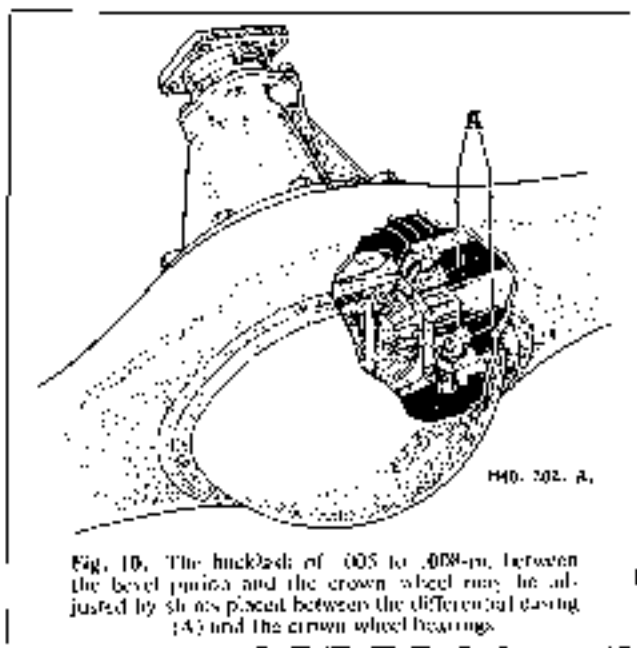

Fig. 10. The backlash of .005 to .008-in. between the bevel pinion and the crown wheel may be adjusted by shims placed between the differential casing (A) and the crown wheel bearings.

When all the bolts have been tightened the axle shafts (which are interchangeable from left to right) can be threaded through the hubs and secured on to the four wheel studs as described earlier for the reassembling of the hubs. When connecting up the propeller shaft use new lockwashers under the four nuts. Replace the axle drain plug and refill the unit with oil.

#### **Crown Wheel and Bevel Pinion Gears**

The crown wheel and pinions are specially mated at the works and in consequence one or the other of the mated parts should never be mated with a new opposite component.

#### **Axle Unit—To Remove Complete**

Disconnect the handbrake cable from the brake balance lever and the short piece of flexible hydraulic brake hose from the "T" junction on the axle casing.

Remove the propeller shaft bolts at the pinion flange.

Jack up the frame at both sides and remove the locknuts or Simmonds self-locking nuts, from the spring clips ("U" bolts). The axle is then free and can be withdrawn for further dismantling. Carefully remove the pad from between the spring and axle spring bracket. It has a hole for location over the spring centre bolts. When reassembling, make sure this pad is properly located, so that the spring pin fits into the centre hole.









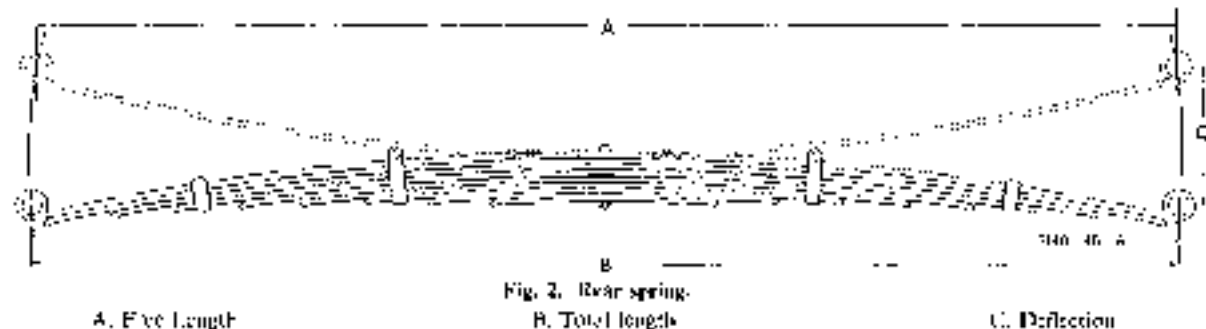

Fig. 2. Rear spring.  
B. Total length

A. Eye length

C. Deflection

### Dismantling a Spring

First remove the banding tape. Grip the spring in a vice, with the vice jaws against the top and bottom leaves, adjacent to the centre bolt. Free the two outside leaf clips by opening them out with a suitable punch and hammer. In the case of the two inside leaf clips, the riveted pin should be unscrewed, or if this is not possible the threaded end should be centre-punched and counter-sunk away with a drill. The pin can then be driven out and the centre bolt withdrawn.

Carefully open the vice when the spring leaves, together with the zinc interleafing, will separate. These should now be thoroughly examined for signs of failure or cracks. Replace any defective leaves, thoroughly clean and regrease. Also see that the rivets are tight which hold the leaf clips to the bottom spring leaf of those leaves they secure.

Replace the spring in a vice. Utilising a rod of similar diameter to the clamping bolt and having a tapered end, position the leaves so that the clamping bolt can be readily replaced, without the risk of damage to the thread.

Replace the clamping bolt and nut followed by the leaf clips which should be carefully refitted. New pins will have to be fitted to the inside leaf clips.

### Removal and Replacement of Shackle Bushes Spring Eye

**Spring Eye Bushes:** These are of the silentbloc type and must therefore be pushed clear of the spring eyes by applying pressure to the outer bush of the assembly. A tool similar to that shown in Fig. 3 will greatly simplify this operation. Part of the tool can also be used for replacing the silentbloc bush which must be so positioned that its outer bush is perfectly central in the spring eye. Again pressure must only be applied to the outside bush. When the shackle pin is inserted the nut must be pulled up tight otherwise the silentbloc bush will not operate properly.

**Frame Shackle Bush:** This is of the phosphor bronze type and is in two halves. Each half of the bush can be driven clear of the frame housing by inserting a narrow

drift through the shackle pin opening to bear against the inner end of the bush.

When the old bushes are removed check that the oiling nipple for this shackle is quite clear and then drive the new bushes into position. Lightly grease the shackle pin and insert into the bushes. The tapered end of the shackle pin, on which the single nut and spring washer are fitted, must be lightened first as this will ensure that the shackle link is firmly positioned on the pin. The nut, spring washer and locknut on the other end of the pin must next be secured sufficiently tight to eliminate end play in the shackle, but not so tight that it is impossible to move the shackle links forward or backward.

### Replacing a Spring

When the spring is fully assembled it should be fitted first at the anchor end and then at the shackle end. Remember that the shackle nuts must be pulled up tight, as previously described for the silentbloc bushes. Finally, fit the spring securing clips and secure the springs to the axle. Place spring washers under the Simmonds nuts and tighten them securely. Do not forget the pad placed between the spring and the rear axle.

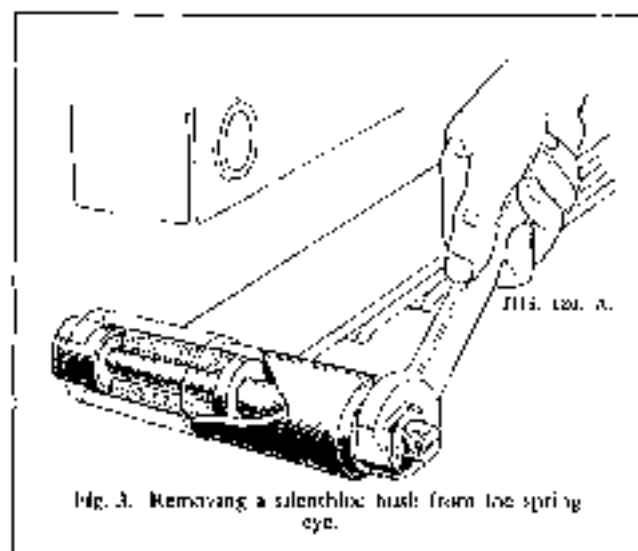

Fig. 3. Removing a silentbloc bush from the spring eye.

## SHOCK ABSORBERS AND ANTI-ROLL BAR

### Description

The shock absorbers are Armstrong double-acting hydraulic, resistance being offered to the compression and to the recoil of the road springs.

A special anti-roll bar is fitted across the rear of the chassis, being firmly attached to the shock absorber arms (see Fig. 4).

Shock absorber maintenance in position on the vehicle is confined to the periodical examination of the anchorage to the chassis, the two fixing bolts being tightened as required, and inspection for leaks.

No adjustment is required or provided for, and any attempt to dismantle the piston assembly will seriously affect the performance of the shock absorber. A shock absorber that is suspected of being faulty must be removed for testing.

Move the lever arm up and down through its complete stroke. A moderate resistance throughout the full stroke should be felt.

If resistance is erratic, and free movement of the lever arm is noted, it may indicate lack of fluid. If the addition of fluid as described gives no improvement, a new or reconditioned unit must be fitted.

Too much resistance, when it is not possible to move the lever arm slowly by hand, may indicate a broken internal part or a seized piston in which case the unit will have to be replaced.

### Topping-up with Fluid

Before removing the filler plug (A, Fig. 4), carefully wipe clean the exterior of the shock absorber body. This is most important, as it is vital that dirt or foreign matter on no account enters the interior of the unit.

Ensure that only Armstrong recommended shock absorber fluid is used for topping-up.

While adding fluid the lever arm must be worked throughout its full stroke to expel any air that might be present in the working chamber.

### Fluid Level

Fluid should be added to the level of the filler plug hole.

### Refitting the Shock Absorbers

When handling shock absorbers that have been removed from the chassis for any purpose, it is important to keep the assemblies upright as far as possible, otherwise air may enter the working chamber and cause erratic resistance.

### Shock Absorber Arm Rubber Bushes

The rubber bushes integral with both ends of the connecting link which joins the shock absorber to the rear axle cannot be renewed. When these bushes are worn the arm must be renewed completely.

### Anti-Roll Torsion Bar

The anti-roll bar is bolted between the two shock absorber arms, being anchored at each arm by a bolt, nut and spring washer, and by a "U" bolt with nuts and spring washers.

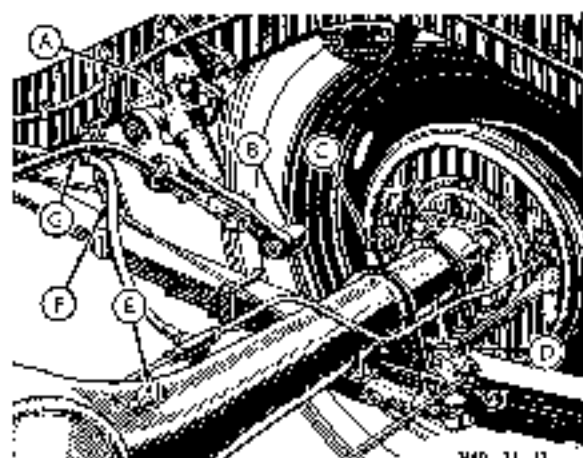

300. 11. 0.

Fig. 4. A. Shock absorber filler plug. B. Shock absorber arm rubber bearing. C. Rear brake adjuster. D. Rear brake balance lever. E. Rear axle breather. F. Rear brake cable pivot. G. Anti-roll bar.

### Testing

When there is any doubt that the rear suspension of the car is not adequately damped, the conditions of the road springs and tyre pressures should be borne in mind.

If the shock absorbers do not appear to function satisfactorily, an indication of their resistance can be obtained by carrying out the following check:

Remove the shock absorbers from the chassis. Place individually in a vice, taking care to grip by the fixing lugs, to avoid distortion of the cylinder body.













# BRAKES

## GENERAL DATA

Make	.. .. .	Girling
Type	.. .. .	Hydraulic, Two-leading shoe front
Pedal Free Movement	.. .. .	1-in. (25.4 mm.)
Handbrake	.. .. .	Pistol Grip Type
		Mechanical on Rear Wheels only

Total Braking Area.	(Saloon)	83 sq. in. (535.5 cm. <sup>2</sup> )
	(Sports)	129 sq. in. (832.2 cm. <sup>2</sup> )

Inside Drum Diameter.	(Saloon)	9-in. (22.86 cm.)
	(Sports)	10-in. (25.4 cm.)

Shoe Lining Width.	(Saloon)	1½-in. (31.75 mm.)
	(Sports)	1⅞-in. (44.45 mm.)

Shoe Lining Length:		
Front and Rear (Saloon)	.. .. .	8 3/4-in. (21.08 cm.)
Front (Sports)	.. .. .	9.44-in. (23.97 cm.)
Rear Leading Shoe (Sports)	.. .. .	9 4/4-in. (23.97 cm.)
Rear Trailing Shoe (Sports)	.. .. .	8 5/8-in. (21.74 cm.)

Shoe Lining Thickness:		
Front and Rear	.. .. .	⅜-in. (4.76 mm.)

### Principle of the System

The hydraulic system consists of a supply tank which should be maintained at its correct level with genuine Girling Crimson Brake Fluid, a master cylinder in which fluid pressure is generated, wheel cylinders which transmit fluid to the brake shoes, and a pipe line consisting of tubing, hoses and unions connected to the cylinders.

The application of the foot pedal operates a piston in the master cylinder, applies pressure to the fluid in the system, which causes the wheel cylinder pistons to expand the brake shoes.

When all the brake shoes are in contact with the drums, solid resistance is obtained at the pedal. Further effort at the pedal generates high pressure in the master cylinder and throughout the system, therefore increasing the force applied to the brake shoes.

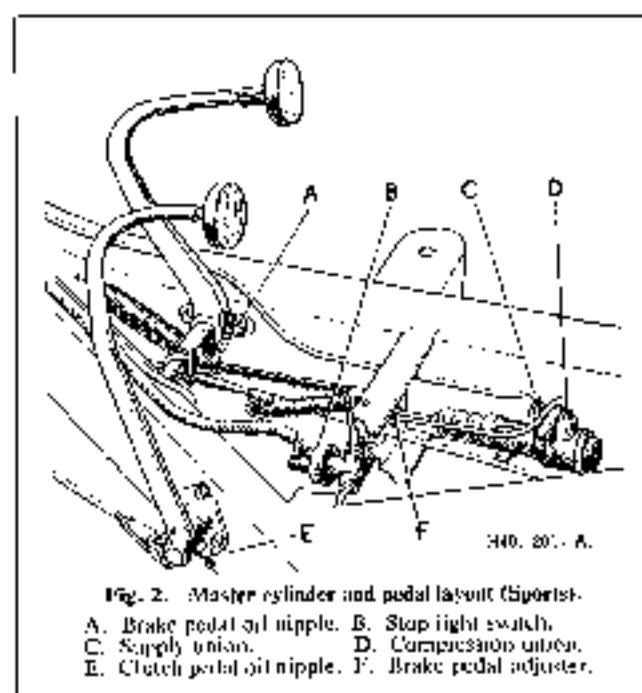

Fig. 2. Master cylinder and pedal layout (Sports).

- A. Brake pedal oil nipple. B. Stop light switch.  
C. Supply union. D. Compressor union.  
E. Clutch pedal oil nipple. F. Brake pedal adjuster.

The pressure generated in the master cylinder is transmitted with equal and undiminished force to each wheel cylinder, thus producing perfect equalisation and efficiency in direct proportion to the effort applied at the pedal.

When the pedal is released, the brake shoe return springs force the wheel cylinder piston, and therefore the fluid, back to the original position in the system.

### Handbrake

This control is situated beneath the fascia, close to the steering column, and operates mechanically on the rear wheels only. Adjustment must be made at the point where the handbrake rod is attached to the handbrake lever (see Fig. 3), but on no account should an attempt be made to take up play by adjusting the handbrake cable.

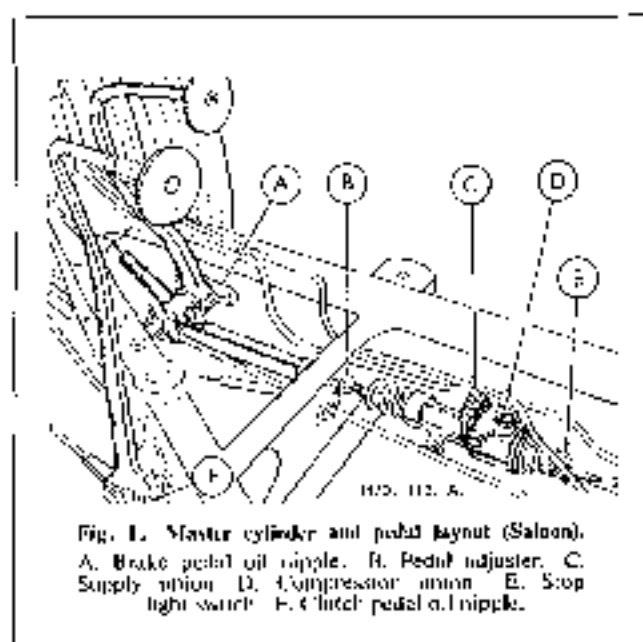

Fig. 1. Master cylinder and pedal layout (Saloon).

- A. Brake pedal oil nipple. B. Pedal adjuster. C. Supply union. D. Compressor union. E. Stop light switch. F. Clutch pedal oil nipple.

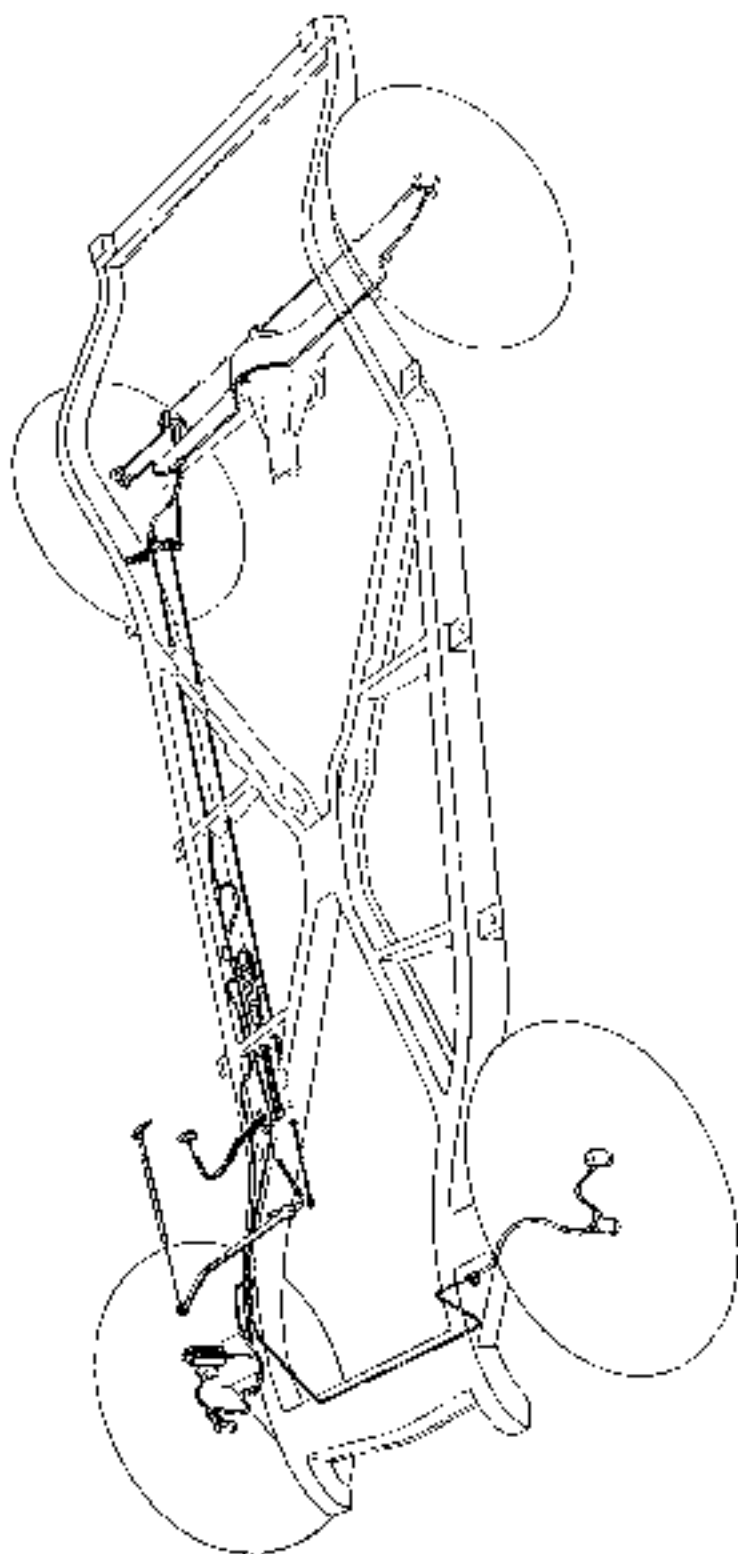

FIG. 338. B.

Fig. 3. A general arrangement of the parking system showing both the full system and parking brake layouts

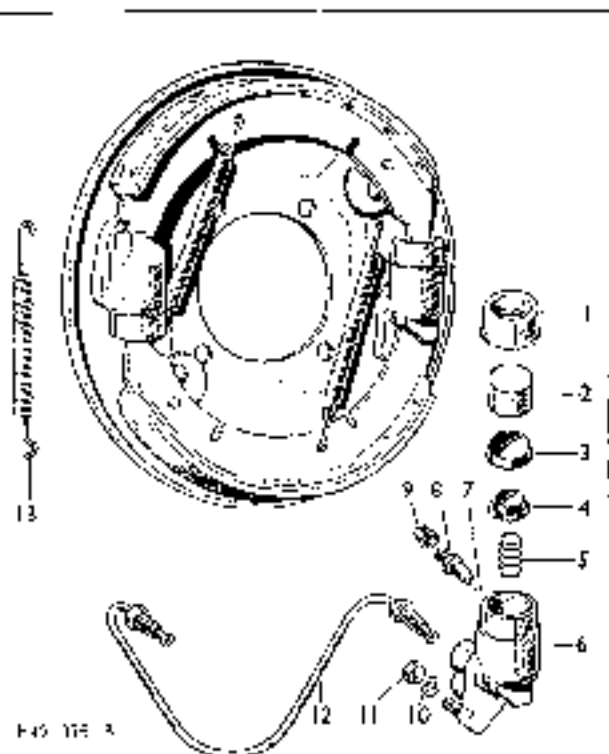

Fig. 4. Front brake back plate.

- |                      |                         |
|----------------------|-------------------------|
| 1. Dust cover.       | 8. Bleed screw.         |
| 2. Shoe plungers.    | 9. Head shoe cover.     |
| 3. Seal.             | 10. Spring washer.      |
| 4. Seal support.     | 11. Retaining nut.      |
| 5. Spring.           | 12. Cylinder.           |
| 6. Cylinder housing. | 13. Connecting pipe.    |
| 7. Bleed valve ball. | 14. Shoe return spring. |

### Front Brakes

The front brake shoes are operated by two wheel cylinders of simple construction, located on opposite sides of the back plate. Each of these cylinders is fitted with one piston, complete with dust cover, which is fixed on the piston. The rear of the cylinder casting is formed to create a 28 degree faced abutment provided with a steel strip which is the locating slot for the shoes. It will be seen that each shoe is located on one cylinder and expanded by the piston of the other with the leading edges of both shoes making initial contact with the drum; thus increased efficiency and more even lining wear is obtained owing to the sliding action of the shoes.

The brake shoes are held in position by two return springs, the ends of which locate in two holes one in the back plate and the other in the brake shoe.

Adjustment for lining wear is provided by knurled snail cam adjusters which operate against a peg at the actuating end of the shoes. Both adjusters turn clockwise to expand the shoes.

The two wheel cylinders are inter-connected by a bridge pipe which passes from cylinder to cylinder on the reverse side of the back plate, provision being made for a bleed valve on one cylinder only.

Each wheel cylinder, the bodies of which are made from alloy, consist of a seal retaining spring, a bakelite seal spreader, seal and piston. The bleed valve which is incorporated on one cylinder, is provided with a steel ball; this is normally seated firmly on a valve opening in the cylinder. Only when the bleed valve is partially opened can the fluid escape.

Fig. 5. Brake back plate and rear layout.

- |                                  |
|----------------------------------|
| A. Rear brake adjuster.          |
| B. Bleed nipple.                 |
| C. Balance lever pivoting point. |
| D. Brake fluid pipe.             |
| E. Handbrake cable.              |
| F. Flexible hose.                |
| G. Handbrake cable and rod link. |

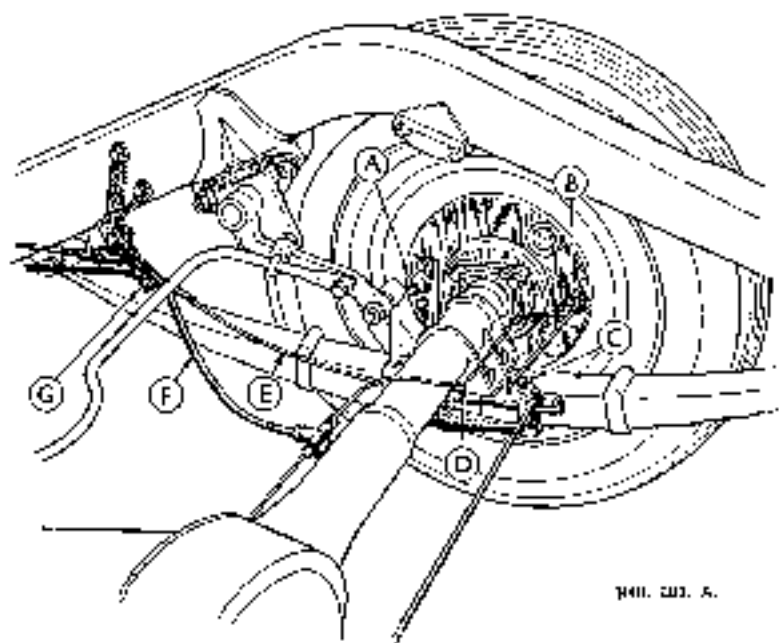

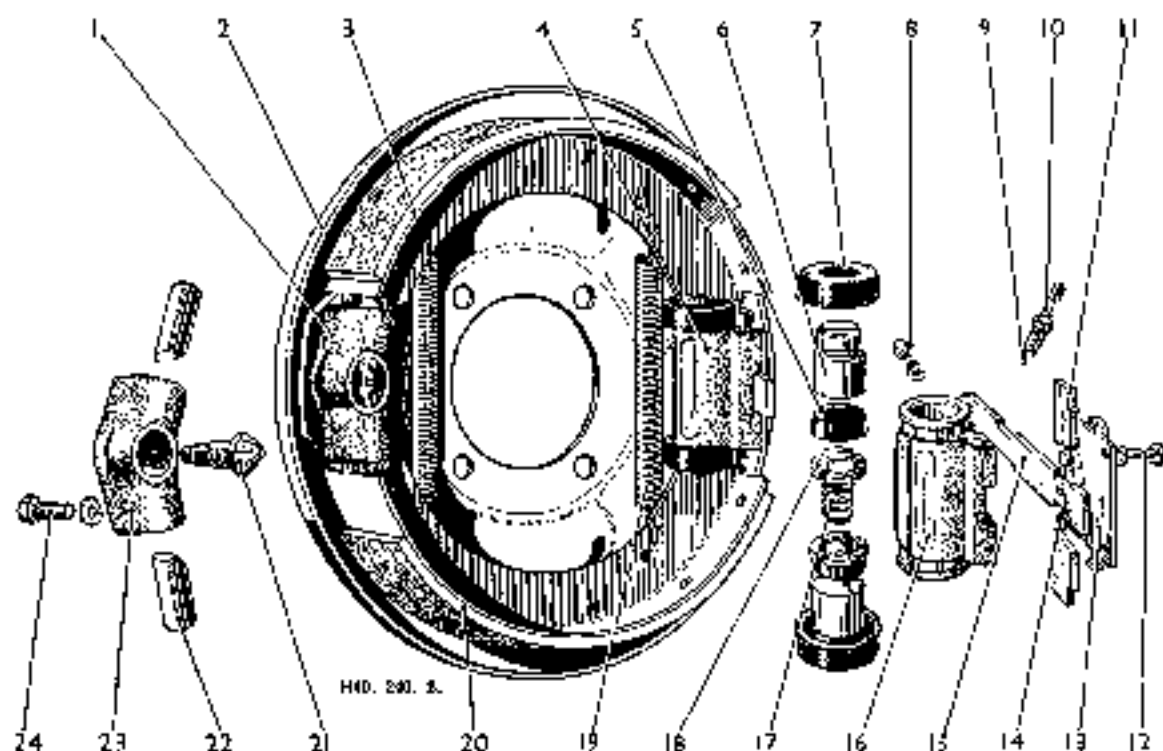

Fig. 6. Rear brake back plate.

- |                            |                       |                         |
|----------------------------|-----------------------|-------------------------|
| 1. Adjustment unit.        | 9. Bleed valve ball.  | 17. Seal spring.        |
| 2. Back plate.             | 10. Bleed screw.      | 18. Seal support.       |
| 3. Shoe and lining.        | 11. Expander tappet.  | 19. Return spring.      |
| 4. Hydraulic cylinder.     | 12. Setscrew.         | 20. Shoe and lining.    |
| 5. Rubber seal.            | 13. Cover plate.      | 21. Adjustment wedge.   |
| 6. Piston.                 | 14. Taper roller.     | 22. Operating link.     |
| 7. Dust Cover.             | 15. Roller wedge.     | 23. Adjustment housing. |
| 8. Housing cut and washer. | 16. Cylinder housing. | 24. Seipin and washer.  |

NOTE: As illustrated some models have indented shoe steady rests instead of the adjustable kind.

### Rear Brakes

The rear brake shoes are hydraulically operated by a wheel cylinder which consists of a die cast aluminum housing, two plungers complete with dust covers, two seals, two bakelite seal retainers, and a seal retaining spring.

The handbrake expander housing, which is part of the wheel cylinder casting, consists of a hardened steel wedge which also acts as the draw link, two hardened steel rollers and two flat inclined faced hardened steel tappets. The retaining cover, which is secured to the housing by four setscrews, fits two tabs; these prevent the plate tappets from sliding out of the housing when the brake shoes are removed. A bleeder valve is also incorporated in the cylinder housing, a rubber cover being fitted to exclude dust, etc. The shoes are located at the adjustment end, in the slots provided in the adjuster plungers, being held in position by two springs from shoe to shoe, the shorter of the two is fitted at the adjuster end of the shoes. Two adjustable steady rests are provided, one under each shoe. The

shoe return springs fitted between the shoes and the back plate ensure that the shoes rest upon the posts.

It will be seen that the shoes are not anchored in any fixed position but are allowed to slide both at the hydraulic pistons and the adjuster links. By this method the efficiency of the brakes is greater than the normal fixed pivot type.

Adjustment for lining wear is made by the brake shoe adjuster. This consists of a hardened steel wedge, the spindle of which is screwed with a fine thread and is carried in a steel bearing, which is spigoted and bolted firmly to the back plate. On the outside end of the wedge spindle are machined flats, which enable a spanner to be used, and on its inner face four flats (of a predetermined depth) are cut. The wedge engages two links, also with a bearing in the housing, which have inclined faces. On the outer end of these links, grooves are formed in which the brake shoes are located. For adjustment the rotation of the wedge in a clockwise direction causes it to move inwards, forcing the links apart and expanding the fulcrum end of the brake shoes. The adjuster should be

tightened up until a resistance is felt and then slackened back two clicks.

### The Master Cylinder

This is the Girling compression type of cylinder and it is fixed to the chassis frame by two bolts.

The assembly as shown in Fig. 7 consists of a cast-iron housing with a highly finished bore into which is assembled the plunger, complete with return spring, recuperating seal, outer seal and seal retainer. The plunger is operated by means of a push rod, with hardened ball end, locating in a specially formed hardened steel seating. The whole is protected from dirt and dust by means of a rubber dust cover, packed with Girling Rubber Grease No. 3.

### Dismantling the Master Cylinder

Before removing the master cylinder for dismantling it is advisable to drain off most of the brake fluid by disconnecting one of the flexible brake pipes on the front wheel back plates, lowering the open end into a clean container and pumping the brake pedal until no further fluid enters the container. Re-connect flexible hose.

Disconnect the two pipe unions on the top of the cylinder and disconnect the master cylinder piston rod from its connection at the brake pedal link rod. The master cylinder may now be removed once the two securing screws to the chassis frame have been withdrawn.

First unscrew the end cover and remove complete with gasket, withdraw the plunger return spring. Remove the rubber boot, withdraw the circlip retaining washer and push rod. The plunger complete with seal retainer and end seal is pushed from the pressure end of the cylinder. Remove the recuperating seal from the body.

Carefully examine the various parts and renew any that appear worn or damaged. It is particularly important to renew any of the seals which are perished or worn.

### Assembling the Master Cylinder

Fit the recuperating seal with lips facing the pressure end and make sure that it is correctly seated. Assemble the end seal and seal retainer, with the wider end of the seal next to the plunger and mount it into the cylinder from the recuperating end. Smear the seal and plunger with clean brake fluid.

Reassemble the operating rod and circlip, and replace the plunger return spring, end cap and gasket.

Screw the end cover firmly into position and replace the rubber boot on the cylinder, packing it with Rubber Grease No. 3.

Refit the master cylinder to the chassis and connect up the two pipe unions and the piston rod.

### Fitting of Replacement Brake Shoes

**Front Brakes:** To remove the old shoes first jack up the car and remove road wheels and drums. Lift one shoe out of its abutment slot and release. It will be found quite simple to remove the return spring. The same procedure can be used with the other shoe. To prevent the two wheel cylinder pistons expanding it is advisable to place a rubber band round the cylinders.

Clean down the back plate and turn the adjusters back to the full off position. Assemble the replacement shoes with the swan neck ends of the springs through the holes in the back plate. Each shoe can be replaced independently. The brake shoe steady rests, operating and abutment ends of the shoes should be smeared with Girling brake grease before assembly. Adjust the brakes.

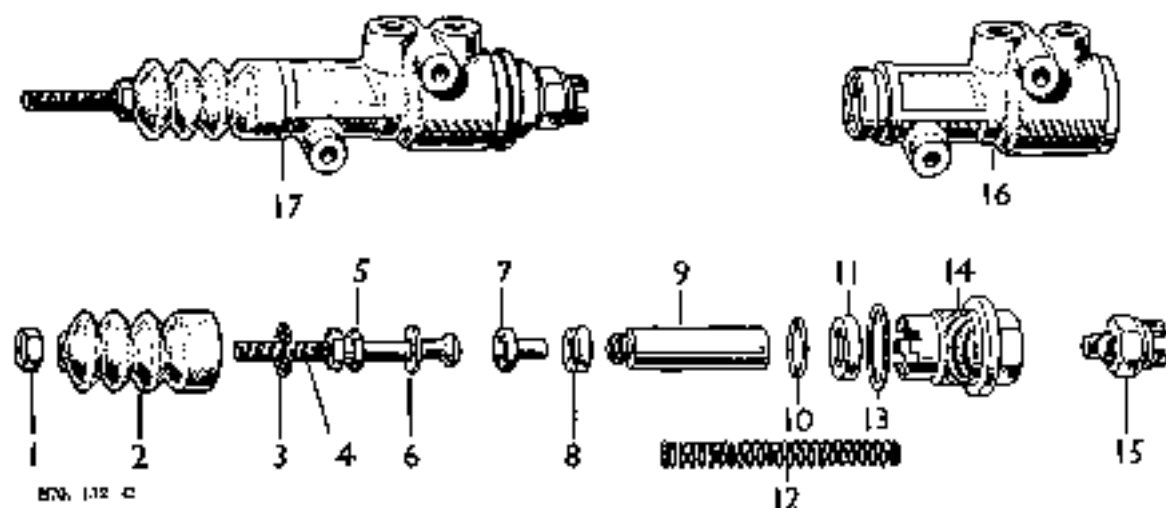

Fig. 7. Components of the master cylinder.

1. Locknut, 2. Rubber boot, 3. Circlip, 4. Push rod, 5. Collar, 6. Retaining washer, 7. Seal retainer, 8. Seal, 9. Plunger, 10. Shim washer, 11. Recuperating seal, 12. Return spring, 13. Gasket, 14. End cover, 15. Stop light switch, 16. Master cylinder body, 17. Master cylinder complete.

**Rear Brakes:**

- (1) Jack up the car and chock the front wheels.
- (2) Remove the wheels and brake drums.
- (3) It will be found quite easy to lift one of the shoes out of the slots provided in the adjuster links and expander tappers. Both shoes can be removed complete with springs.
- (4) Remove the two shoe return springs and replace if stretched or damaged. Fit the new springs to the new shoes with the shorter of the springs at the adjuster end of the shoe and with the springs between shoes and back plate. Locate one shoe in the adjuster and expander slots and prise over the opposite shoe into its relative position. Again it is important that the steady rests and shoe ends should be lubricated with Gilling brake grease.

**Note:** When fitting replacement shoes it is advisable, at all times, to fit a new set of springs.

Always fit Gilling "factory lined" shoes as replacements as these have the correct type of lining and are accurately ground to size, which ensures a fast bed into drums.

**Rear Adjustments and General Maintenance**

The brakes are adjusted for lining wear **ONLY** at the brakes themselves and on no account should any attention be made to the handbrake cable for this purpose.

**Front Brakes**

Jack up the car until the front wheel to be adjusted is clear of the ground and fully release both hexagon head adjuster bolts on the brake back plate. Turn one of the adjuster bolts until the brake shoe concerned touches the brake drum. Release the adjuster until the brake shoe is just free of the drum, and repeat the operation for the second adjuster. As, on the front brake assembly, a separate adjuster is provided for each shoe, spin the wheel to ensure that the brake shoes are quite free of the drum and repeat the adjustment for the second front wheel.

**Rear Brakes**

Adjustment is made by turning the square head adjuster on each rear brake back plate in a clockwise direction until a resistance is felt. The adjuster must then be slackened back two clicks. One common adjuster is provided for both shoes in the rear brake assembly and the adjustment of both rear wheel brakes is identical.

**Replenishment of Hydraulic Fluid**

Inspect the supply tank at regular intervals and maintain about three-quarters full by the addition of Gilling Crimson Brake Fluid. For the Saloon, this tank is mounted on the steering gear side of the radiator

frame and in the Sports, on the fitch plate adjacent to the steering column.

**Note:** Serious consequences may result from the use of incorrect fluids, and on no account should anything other than the specified fluid be used. Great care should be exercised when adding brake fluid to prevent dirt or foreign matter entering the system.

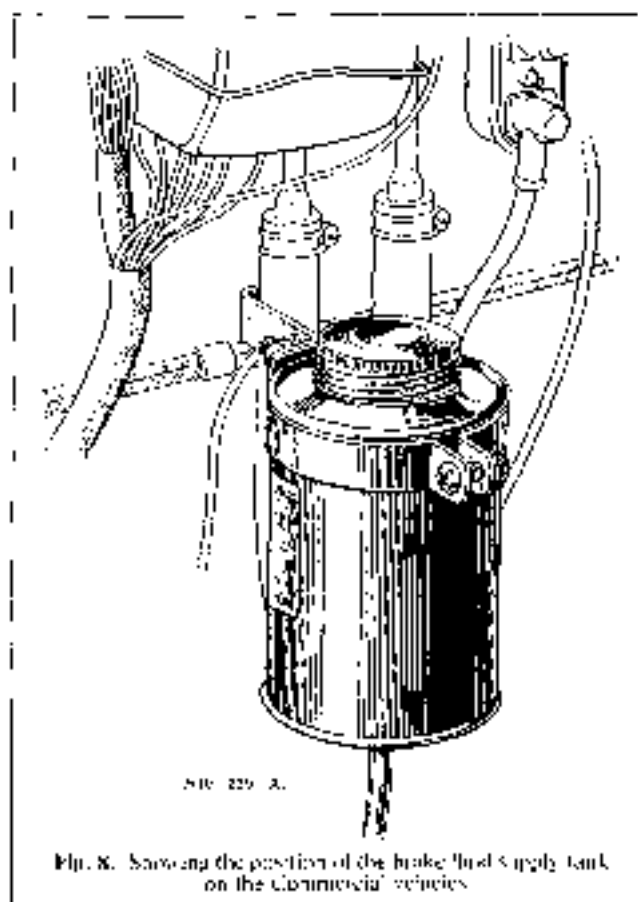
**Bleeding the System**

Bleeding becomes necessary any time a portion of the hydraulic system has been disconnected, or if the brake fluid has been allowed to fall so low that air has entered the master cylinder. The specified fluid has been specially prepared and is unaffected by high temperatures or freezing.

With all the hydraulic connections secure and the supply tank topped with fluid, remove the rubber cover from the right-hand rear brake nipple and fit a length of rubber tube to the nipple, immersing the free end of the tube in a clean jar containing a little brake fluid.

Unscrew the bleed nipple about three quarters of a turn and then operate the brake pedal with slow full strokes until the fluid entering the jar is completely free of air bubbles. Then, during a down stroke of the pedal, retighten the bleed nipple and remove the rubber tube. Replace the bleed nipple dust cover.

**Note:** Under no circumstances must excessive force be used when tightening the bleed screw.

This process must now be repeated at each of the bleed nipples of the brake back plates. Always keep a careful check on the supply tank during the bleeding operations since it is most important that a full level is maintained. Should air reach the master cylinder from the supply tank, the whole of the bleeding operations will have to be recommenced.

After bleeding, top up the supply tank to its correct level.

Never use the fluid that has just been bled from a system for topping up purposes as this fluid may be, to some extent, aerated. Such fluid must be allowed to stand for at least twenty-four hours before it is used again. This will give the air bubbles in the fluid time to disperse.

Great cleanliness is essential when dealing with any part of the system and especially so where the brake fluid is concerned. Dirty fluid must never be added to the system.

#### GENERAL ADVICE

Always exercise extreme cleanliness.

Always use clean brake fluid or alcohol for cleaning internal parts of the hydraulic system. Oil or acetone should petrol or paraffin be used.

Always examine all seals carefully and use only genuine Girling parts for replacement purposes.

Always take care not to scratch the highly finished surfaces of cylinder bores and pistons.

Always use Girling Crimson Brake Fluid.

**Important.** If it is suspected that incorrect fluids have been used all seals in the master cylinder and wheel cylinders must be changed and the components and pipe lines must be cleansed.









# TYRES AND JACKING

**A** MOST important factor in the road-worthiness of the car is systematic and correct tyre maintenance. The tyres must be able to sustain the weight of a loaded car and be able to withstand satisfactorily the vagaries of road conditions. Tyre pressures should, therefore, be checked at least once a week. According to whether right or left-hand rule of the road prevails, both front and rear tyres nearer the kerb should be inflated with a pressure two to three lbs./sq. inch (1.41-2.11 kg./cm<sup>2</sup>) above the pressure in the tyres on the opposite side.

The benefit of this differential pressure will be felt in easier handling and less tyre wear, particularly in countries where roads are winding, and are heavily or even moderately cambered.

## RECOMMENDED TYRE PRESSURES

Model	Rim Size	Tyre Size	Pressures in lbs. per square inch and kg/cm <sup>2</sup> .			
			2 passengers		Full Load	
			Front	Rear	Front	Rear
Saloon	16-3.00	5.25-16	22 (1.517)	24 (1.687)	24 (1.687)	26 (1.828)
Canada and U.S.A.	16-3.50	5.50-16	24 (1.687)	26 (1.828)	24 (1.687)	26 (1.828)
Sports	16-3.00	5.25-16	21 (1.406)	24 (1.687)	23 (1.617)	26 (1.828)
Commercial	17-3.50	5.00-17	24 (1.687)	26 (2.531)	24 (1.687)	26 (2.531)

### General

Easy-fit, pressed steel disc wheels with large chromium centre plates are employed. The four wheel studs are accessible after the chromium-plated wheel disc has been removed by using a screwdriver or thin coin as a lever at the rim. Much harm can be done to a car and its tyres by failure to inspect the tyres regularly for correct inflation.

See that all valves are fitted with valve caps and periodically jack up the car and examine the tyres for cuts, bruises, wall damage and general wear. At the same time remove grit and stones that may be embedded in the tread. It is also important that any tyre which appears to lose an appreciable amount of air in short intervals should be examined at the earliest possible moment for leaks, and if found, these should be repaired immediately.

It is essential to keep oil (particularly paraffin) and grease off the garage floor where the car stands, as their presence on the tyres is injurious to the rubber. Removal must be effected immediately by a light application of petrol, which must be thoroughly wiped away.

The treads must be periodically examined for uneven or excessive wear. Flat spots, feathering or unexpected rapid wear on the tyres will indicate incorrect wheel alignment or brake adjustment and a check should be made immediately.

**Alignment** plays havoc with the front tyres and a periodical check with an alignment gauge, as detailed in Section J, is highly recommended.

Wheel nuts should be tightened frequently, particularly when the vehicle is new or the wheels have been removed and refitted. Lightly grease the stud threads while the nuts are removed.

Cuts found in the tyres should receive attention—major ones by vulcanisation, and minor by the application of special compound. If this is done promptly an extension of the injury will be prevented. It is important that tyres which have sustained damage should be changed immediately.

### Repairing Tyres

Have punctures or injuries vulcanised. Ordinary patches should only be used for emergencies.

### Uneven Wear

Because the front wheels are slightly "cambered" or lean outwards, the outer side of the tyre tread wears more than the inner. To minimise the effect of such wear change the tyres round periodically so that the worn sides are next to the car. It is also a sound policy to interchange tyres on the left and right-hand side of the car at intervals so that unequal weight distribution and consequent wear caused by road camber are shared. The spare tyre should be used in turn with the others.

### Changing a Wheel

Remove the wheel disc and loosen the wheel nuts with the wheel brace. See that the hand-brake is firmly applied and if the car is on an incline, chock one of the wheels not affected. Jack up the car as required, remove the four wheel nuts and remove the wheel.

### Replacing the Wheel

Lightly grease the studs and lift the wheel into position. Replace the wheel nuts and tighten alternately. It is important that particular attention be given to tightening, as loose wheel nuts will cause considerable damage to wheels and studs. Finally replace the steel disc.

### Wheel and Tyre Assembly

Inextensible wires are incorporated in the beads of wired type tyres. Therefore do not attempt to stretch the wire beads of the tyre cover over the rim flange.

Force is unnecessary and may be dangerous as it merely tends to damage the cover beads and serves no useful purpose.

Fitting or removing will be quite easy if the wire beads are carefully adjusted into the rim well. If it is found to be difficult, the operation is not being correctly performed.

### Removing a Tyre

1. Remove all valve parts to deflate the tyre and push back tyre beads off the rim seats.
2. Commence to remove the bead on the valve side of the cover. Insert a lever at the valve position and, while pulling on this lever, push the bead into the well of the rim diametrically opposite the valve.
3. Insert a second lever about 2-in. away from the first lever and gradually prise the bead over the rim flange.
4. Continue with one lever while holding the removed portion of the bead with the other lever. The tube can then be removed.
5. Stand the cover upright with the wheel in front.
6. Insert a lever from the front between the bead and the flange and pull the cover back over the flange.
7. If difficult to remove, keep the strain on the bead with the lever and tap off with a rubber mallet.

### Refitting a Tyre

1. Place the cover on top of the wheel and push as much as possible of the lower bead by hand into the well of the rim. Insert a lever to prise the remaining portion of the lower bead over the rim flange.
2. Slightly inflate the tube until it begins to round out and insert it in the cover with the valve through the hole in the rim. (Take care that the valve, which is fitted to the side of the tube, is on the correct side of the rim.)

3. Commence to fit the second bead by pushing it into the well of the rim diametrically opposite the valve.

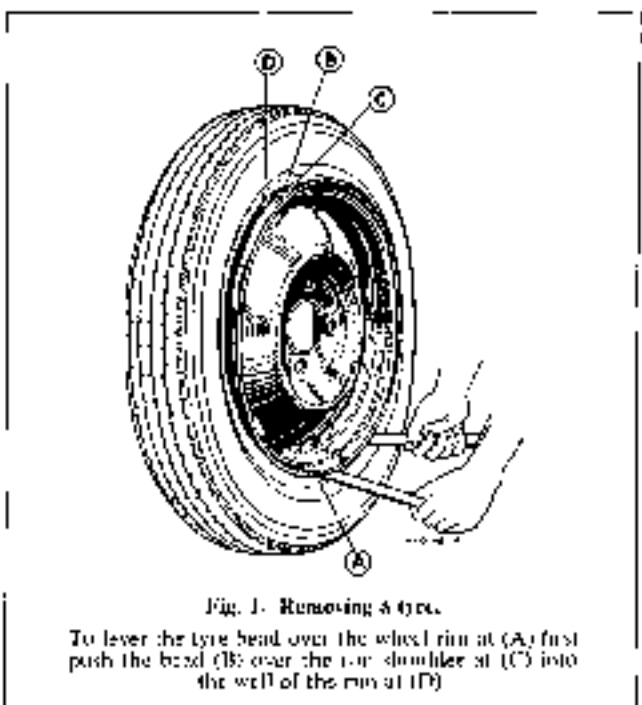

4. Lever the bead over the flange either side of this position, finishing at the valve, when the bead will be completely fitted.
5. Ease the valve in the rim hole and push upwards by hand to enable the heads to seat correctly, and then pull the valve firmly back into position.
6. Inflate the tyre and see that the heads are seated evenly round the rim: check by the line on the cover. **Note:** Water on levers considerably eases the fitting and removing of beads.

### Care in Fitting

Special care in fitting synthetic tubes is essential to obtain maximum life and avoid premature failure. Recommendations when fitting on well base rims are as follows:—

1. Dust the inside of the cover evenly with French chalk.
2. Inflate the tube until it begins to round out; then insert in cover.
3. Apply a frothy solution of soap and water generously around the entire base of the tube, extending upwards between the tyre beads and the tube itself for at least two inches on both sides. Also apply the mixture to the bottom and outside of the tyre beads. Do not allow the solution to run into the crown of the tyre. Mixture must be strong enough to feel slippery when the fingers are wetted and rubbed together.

4. Mount the tyre on the rim whilst the soap solution is still wet.
5. Before inflating, be sure the tyre beads are clear of the well of the rim all the way round.
6. Inflate slowly until the beads are fully seated.
7. Remove the valve core to allow the tube to deflate completely. Do not disturb the beads of the cover.
8. Re-inflate to correct working pressure.

This procedure must be followed whenever a tube is refitted.

The object of double inflation is to permit any stretched portions of the tube to re-adjust themselves in the cover and relieve any strains in the tube.

In an emergency, French chalk may be used as a substitute for soap solution, provided it is evenly and generously applied. This practice, however, is not recommended.

### MAIN POINTS IN TYRE CARE

Precautions to be taken with all tyres, especially synthetic tyres:—

1. Avoid under-inflation and over-inflation by checking pressure at least weekly and adjust pressure when necessary.

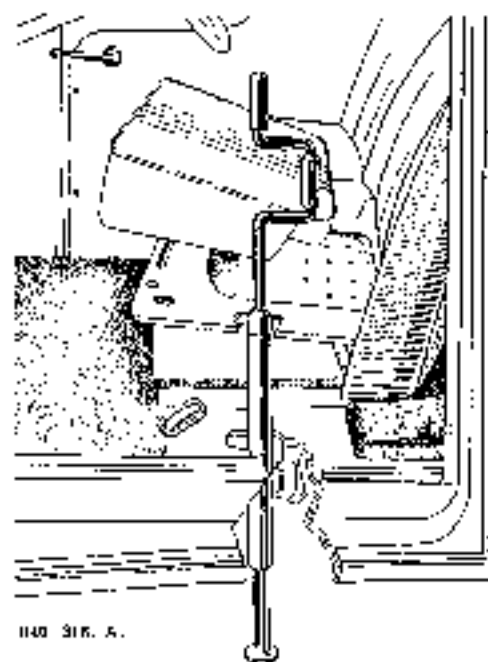

Fig. 2. Showing the car jack in position for the Saloon and Coupé.

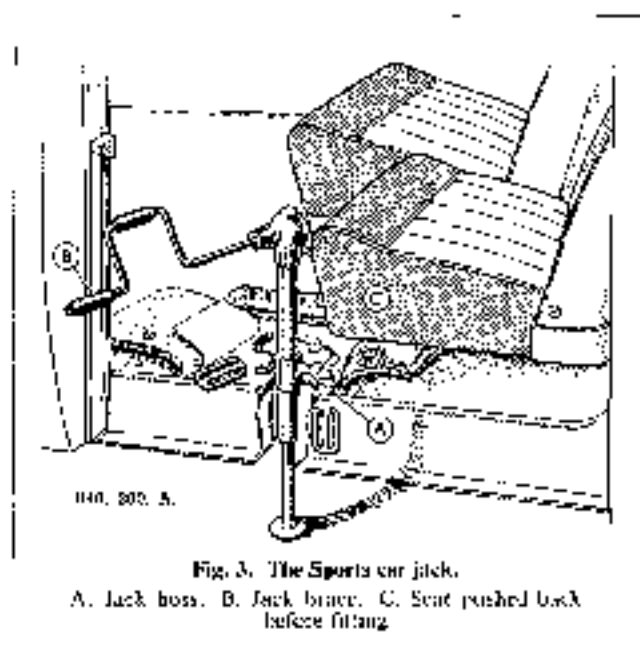

Fig. 3. The Sports car jack.

A. Jack boss. B. Jack brace. C. Seat pushed back before fitting.

2. Avoid sudden stops and fierce acceleration.
3. Avoid high speed, and drive at a moderate speed round turns.
4. Avoid kerbing and other causes of severe impact.
5. Do not allow flints, etc., to remain embedded in the tread.
6. Have damage repaired immediately.
7. Change tyres round regularly, including the spare.
8. Keep brakes in proper adjustment.
9. Have wheels checked regularly for misalignment and other mechanical irregularities.
10. Remove tyres in time for remoulding.
11. Keep the tyres clear of oil or paraffin.

### The Car Jack

The jacking of the car is effected by a Stevenson telescopic jack which operates from a central cross-member of the chassis frame. There are two positions for the jack enabling either the right or left side of the car to be raised.

To jack up the car, first apply the handbrake and then open the hinged flap, situated beneath the front seat, on the side of the car which is to be raised. Lower the Stevenson jack into position through the opening, and ensure that the boss on the jack fits into its socket on the chassis frame cross-member. Before proceeding to wind the jack down with the car wheelbrace, make quite sure that the base of the jack will have a firm and even footing on the ground; then proceed to wind down the jack with the wheelbrace.

Immediately the car is felt to lift re-check that the boss is correctly located within the chassis socket.

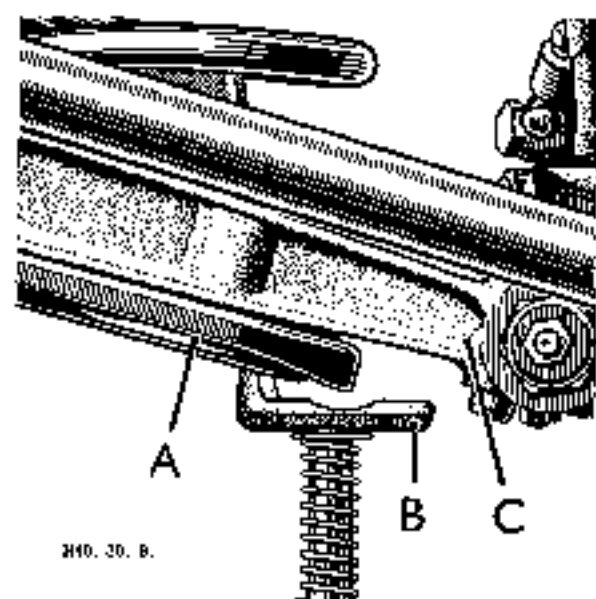

H40, 30, B.

Fig. 4. Front position for screw jack.

- A. Front suspension spring plate.
- B. Jack platform.
- C. Front suspension lower wishbone arm.

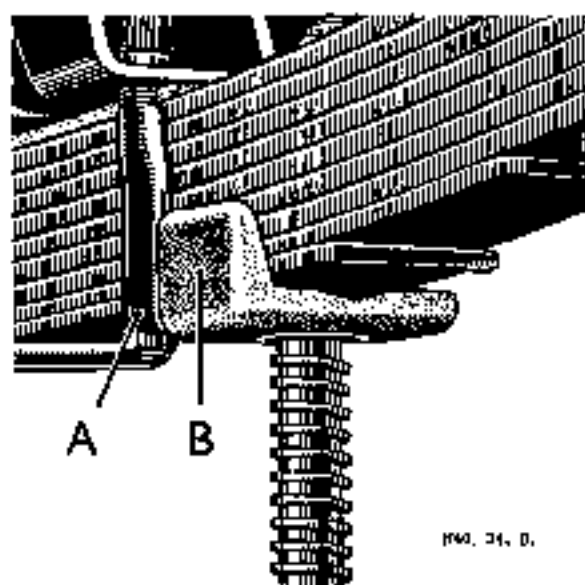

H40, 31, B.

Fig. 5. Rear position for screw jack.

- A. Rear spring "U" bolt
- B. Jack platform top.

#### The Under-Axle Type of Screw Jack

This type of jack is used for the Commercial models. For the front wheels the lifting platform of the jack should be placed across the outer rim of the spring recess in the spring plate.

For lifting the rear wheels, place the lifting platform across the lowest spring leaf, to the rear of the axle, with the lipped end on the outside of the lower plate,

so that the flat end is between the bottom wishbone links and the lipped end projects into the spring and up against the spring U-bolt, this avoids any turning movement.

A long handle is required to operate the jack and this is obtained by joining together the provided extension bar and starting handle, the latter being the turning medium.







# ELECTRICAL EQUIPMENT

**T**his electrical equipment is designed to give long periods of service without need for adjustment or cleaning. The small amount of attention which is required is described under "Lubrication and General Maintenance".

Under "General Information" details are given on the operation of the various items of the equipment and descriptions on the method of setting the lamp beams and fitting replacements, such as bulbs, high tension cables, bearing bushes, etc., which may become necessary from time to time.

## GENERAL DATA

### Battery

Lucas, G.T.W. 7A, 38 ampere hours capacity at 10 hour discharge rate.

### Dynamo

Lucas, Type C, 39pV-2. Nominal Voltage, 12; cutting-in speed, 1050-1200 r.p.m. (dyn.), at 13.0 volts; maximum output, 19 amps. 13.5 volts at 2000-2150 r.p.m. (using a 0.7 ohm resistance load capable of carrying 19 amps. without overheating); field resistance, 6.2 ohms; brush spring tension, 25-22 ozs. (.7087-.6237 kg.).

### Distributor

Lucas, Type DM. 2A114.

### Ignition Coil

Lucas, Type Q12 (Saloon and Commercials), Type B12 (Sports)

### Cut-Out

Lucas compensated voltage control, Type RB106; Cut-in voltage, 12.7-13.3. Drop-off voltage, 9-10; reserve current, 3-5 amps.

### Starter Motor

Lucas, Type M35G/1 controlled by pullout knob on Instrument Panel. Nominal Voltage, 12; lock torque,

9.3 lb. ft. (1.2358 kgm.); current, 325-345 amps. at 8.1-7.7 volts; torque at 1,000 r.p.m., 4.9 lb. ft. at 200-230 amps. and 9.3-8.9 volts; brush spring tension, 25-15 ozs. (.7087-.4152 kg.).

### Fuse Unit

Contains two 'live' fuses and two spares. Fit 30-amp. fuse between terminals A1-A2 and 35-amp. fuse between terminals A3-A4.

### Trafficators

Type SF.80. Controlled from the centre boss of the steering wheel, of the self-cancelling type.

### Windscreen Wipers

Type CRT. 14. Control switch on dash-board, automatic over-load protection.

### Lamp Bulbs

Headlamp: U.K. and R.H.D. countries, Lucas No. 354. 12 volt 42/36 watt. U.S.A. and L.H.D. countries, Lucas No. 355. 12 volt 42/36 watt. Europe except France, Lucas No. 350. 12 volt 35/35 watt. (France, special 2-pin, not Lucas.) Side lamps and number plate lamp: Lucas No. 989 12 volt 6 watt. Stop-tail lamps: Lucas No. 361 12 volt 18/6 watt. Panel lights, ignition and main beam warning lights: Lucas No. 987 12 volt 2.2 watt. "Trafficator" bulbs: Lucas No. 256 12 volt 3 watt (festoon).

## LUBRICATION AND GENERAL MAINTENANCE

After the first 500 miles running.

### Distributor

Remove the moulded distributor cover and turn the engine over by hand, carefully observing that the contacts in the distributor are fully opened. Check the gap with an 0.014-0.016-in. (.3556-.4064 mm.) gauge. If the setting is correct the gauge should be a sliding fit,

otherwise the contact breaker should be adjusted. To carry out the adjustment, keep the engine in the position to give maximum opening of the contacts and slacken the two screws which secure the contact plate to the distributor body. Move the plate until the gap is set to the thickness of the gauge and then fully tighten the locking screws. Recheck the gap.

Austin A40 "Sumerset" Wiring Diagram.

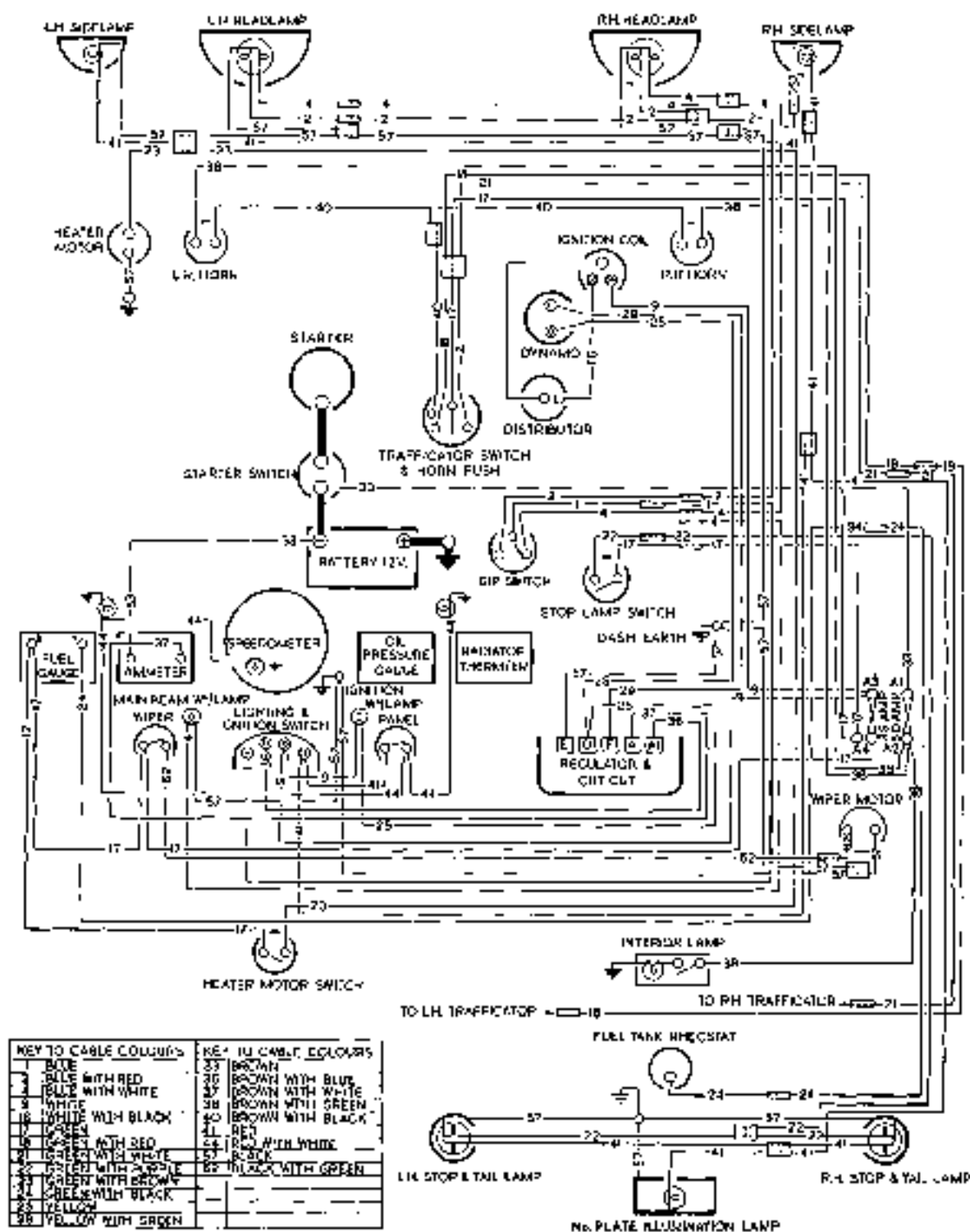

E 1265

Fig. 1. General arrangement of the electrical circuits and components of the Saloon and Coupé.  
 Note: The interior lamp is not fitted to the Coupé.

Austin A40 Commercial Wiring Diagram.

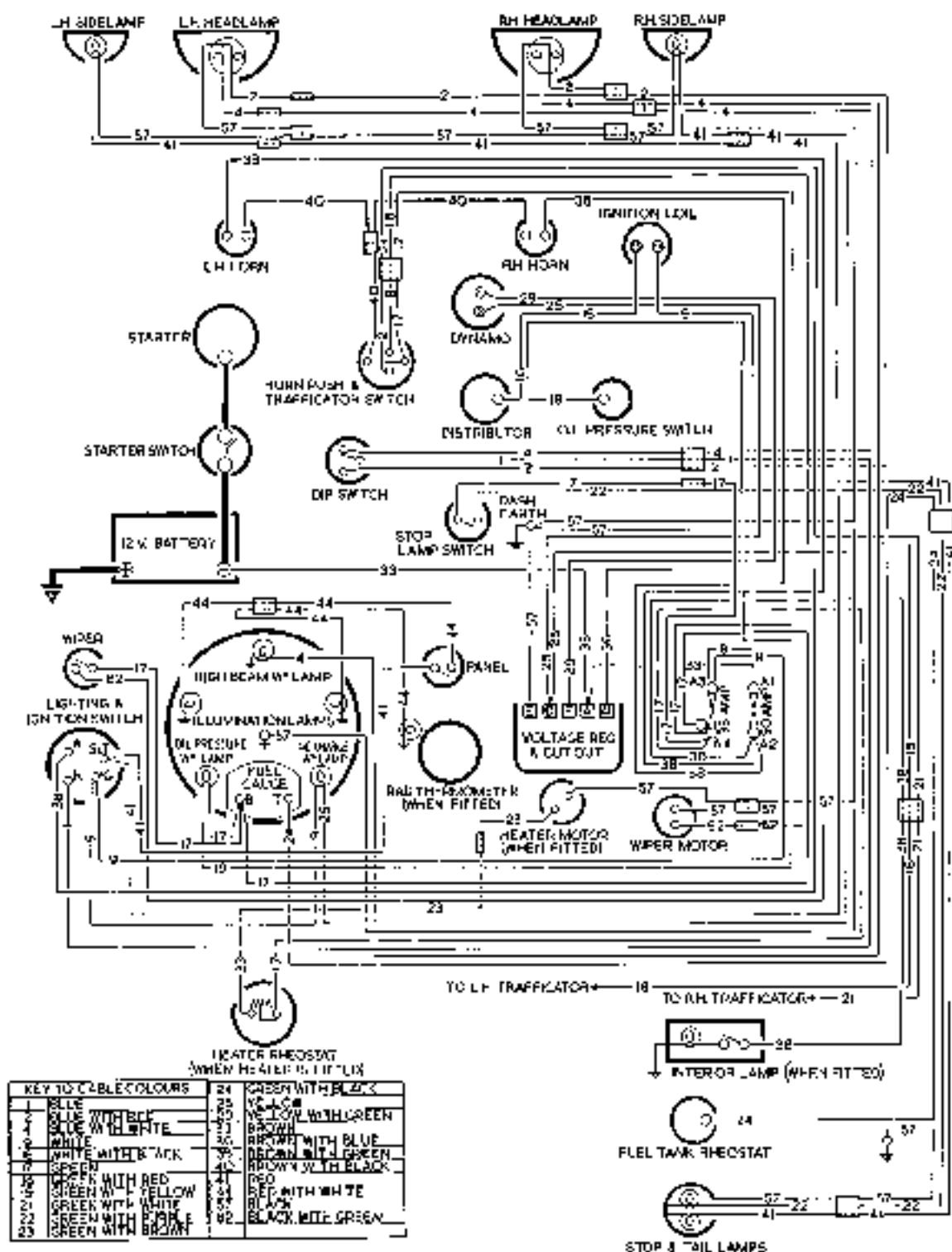

E1255

Fig. 2. The general circuit layout as employed on the A40 Commercial vehicles.

Austin A40 Sports Wiring Diagram.

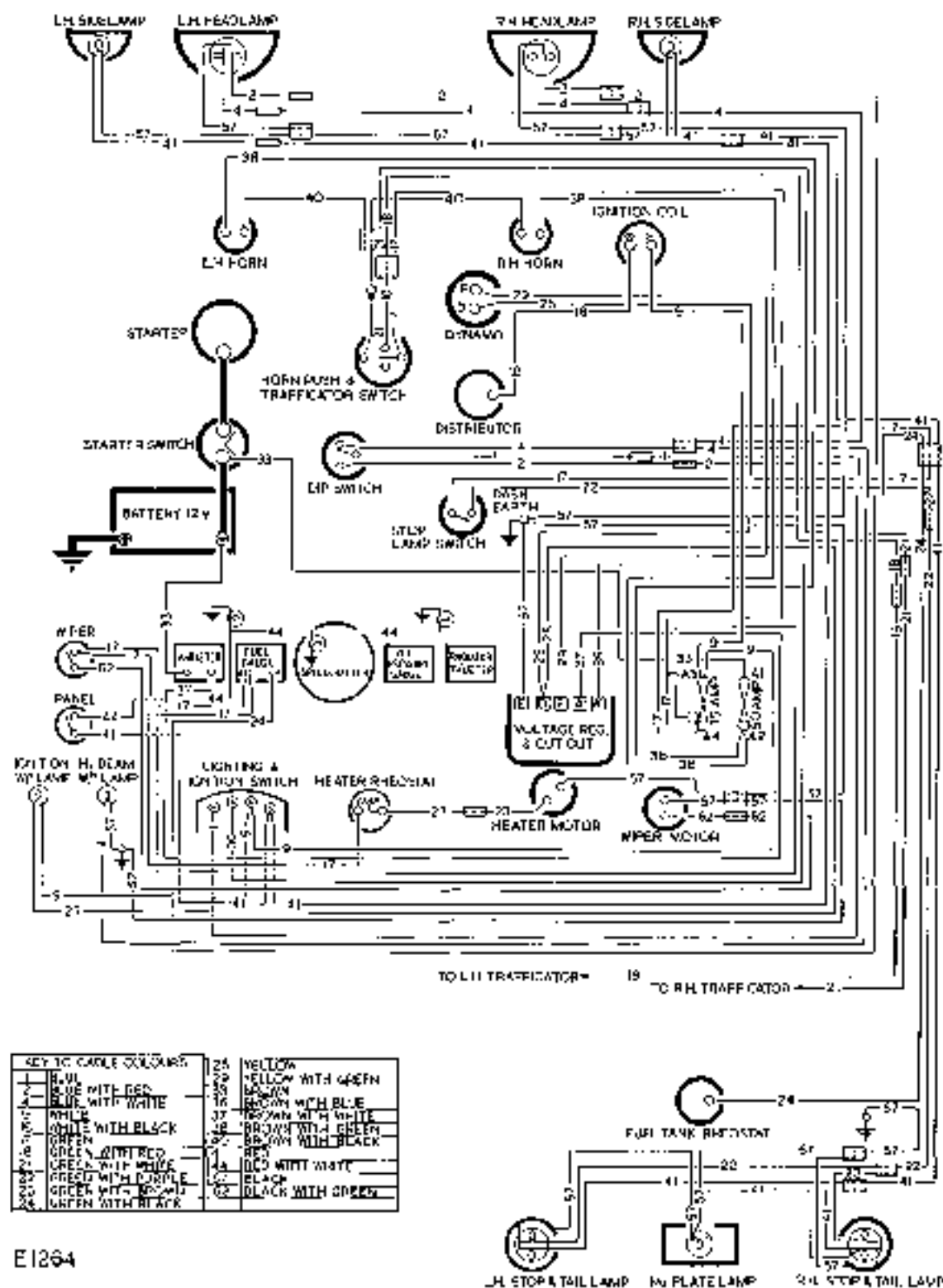

Fig. 3. The electrical circuits of the A40 Sports with relative component locations.

## EVERY 2,000 MILES

**Battery**

About every 2,000 miles or more often in hot weather, take out the filler plugs from the top of the battery. Check the level of the electrolyte in each cell and if necessary add distilled water to bring the electrolyte level with the top of the separators. The use of a Lucas Battery Filler will be found helpful when topping up, as it ensures correct electrolyte level, and also prevents distilled water from being spilled over the top of the battery. If any is spilled, wipe it away and ensure that the top of the battery is kept clean and dry. Remove any dirt from the holes in the vent plugs with a piece of wire.

*Note:* Do not add tap water to a battery, and do not use a naked light when examining the battery cells. Examine the terminals and if they show an oxide film scrape them clean, and coat with petroleum jelly. Make sure that the connections are clean and tight.

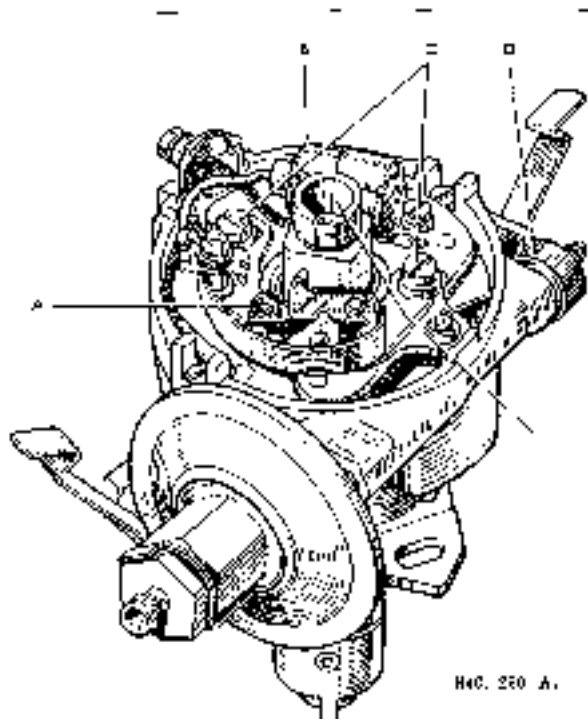

H.C. 250 A.

Fig. 5. Distributor platform.

A. Contact points. B. Capacitor. C. Contact adjusting screws. D. Micrometer adjuster. E. Cam and drive shaft oiling point.

**Distributor Lubrication****Cam**

Tightly smear the cam with a very small amount of recommended lubricant (see Section T).

**Cam Bearing and Distributor Shaft**

Lift the rotor arm off the top of the spindle by pulling it off vertically and add a few drops of lubricant to the cam bearing.

Replace the rotor arm correctly and push it on to the shaft as far as it will go.

**Automatic Timing Control**

Carefully add a few drops of lubricant through the hole in the contact breaker base through which the cam passes. Do not allow any oil to get on or near the contacts.

**Contact Breaker Pivot**

Place a small amount of lubricant on the pivot on which the contact breaker lever works. Do not allow oil or grease to get on to the contacts.

## EVERY 4,000 MILES

Carry out the procedure for every 1,000 and 3,000 miles, together with the following:—

**Distributor-cleaning.** Wipe the inside and outside of the moulded distributor cover with a soft dry cloth,

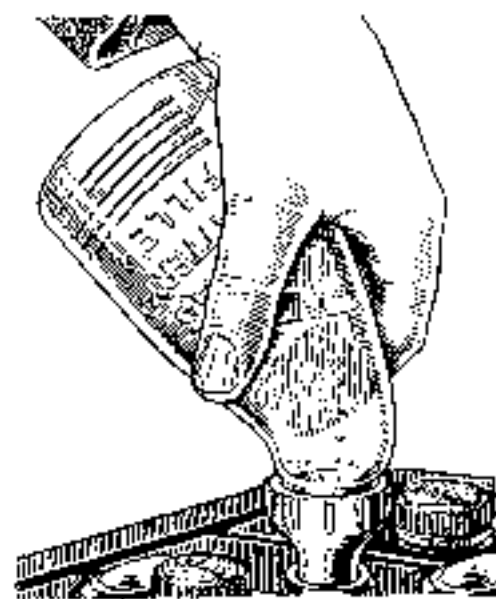

H.C. 21. A.

Fig. 4. Using a Battery Filler to top-up the battery

If the cable connectors are removed from the battery lugs for any purpose, on refitting, fill the screw recess with petroleum jelly, both before and after fitting the self tapping screw.

If the connectors are fitted too tightly on the tapered battery posts, difficulty may be experienced when they have to be removed.

## EVERY 3,000 MILES

Carry out the procedure for every 2,000 miles, together with the following:—

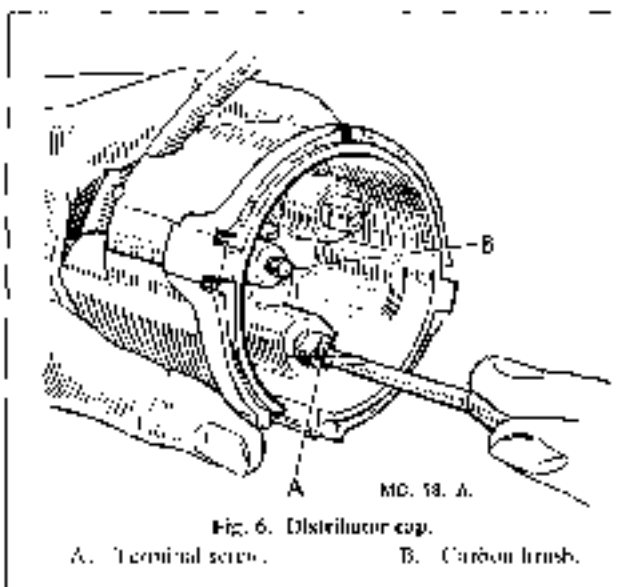

Fig. 6. Distributor cap.

A. Terminal screw. B. Carbon brush.

paying particular attention to the space between the terminals. See that the small carbon brush on the inside of the moulding works freely in its holder and that the terminals are secure.

Examine the contact breaker. The contacts must be free from grease or oil. If they are buried or blackened, clean them with a very fine carborundum stone or with very fine emery cloth (see Fig. 7). Afterwards wipe away any trace of dirt or metal dust with a petrol moistened cloth.

Cleaning of the contacts is made easier if the contact breaker lever carrying the moving contact is removed. To do this remove the nut, washer, insulating piece, and connections from the post to which

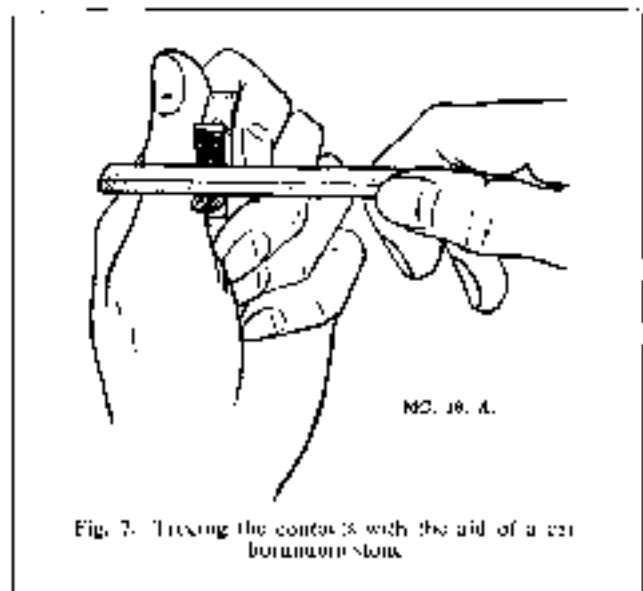

Fig. 7. Tracing the contacts with the aid of a carborundum stone.

the end of the contact breaker spring is anchored. The lever can then be lifted off its pivot pin. After cleaning check the contact breaker setting.

If the contacts are badly burned, they should be renewed. Replacement contacts must only be fitted in pairs. To remove the moving contact, follow the procedure outlined above. To remove the plate carrying the fixed contact take out the two screws complete with spring washers and flat steel washers. The replacement set of contacts can now be refitted by a reversal of the above.

Check the adjustment of the contact breaker gap as described in "After the first 500 miles running".

### Turbine Lubrication

Apply by means of a small brush, or other suitable article, a drop of recommended lubricant to the bearing on which the arm pivots. Use only the slightest trace as any excess may adversely affect the operating mechanism.

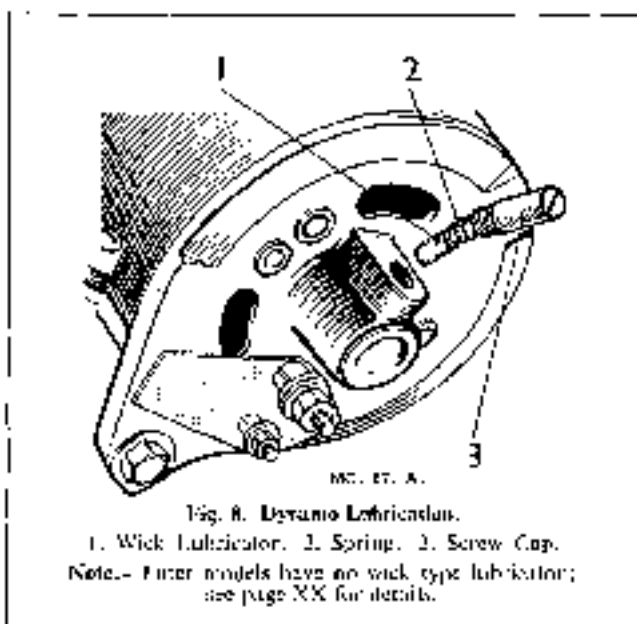

Fig. 8. Dynamo Lubrication.

1. Wick Lubricator. 2. Spring. 3. Screw Cap.  
Note.— Later models have no wick type lubricator; see page XX for details.

### EVERY 12,000 MILES

#### Dynamo Lubrication

After about every 12,000 miles running, unscrew the lubricator at the end of the dynamo, lift out the felt pad and spring and about half fill the lubricator with D.M.P. grease. Replace the spring and felt pad and screw the lubricator into position (see Fig. 8).

## GENERAL INFORMATION

### BATTERY

It is advisable to check the state of charge of the battery occasionally by measuring the specific gravity of the electrolyte in each of the cells by means of a hydrometer.

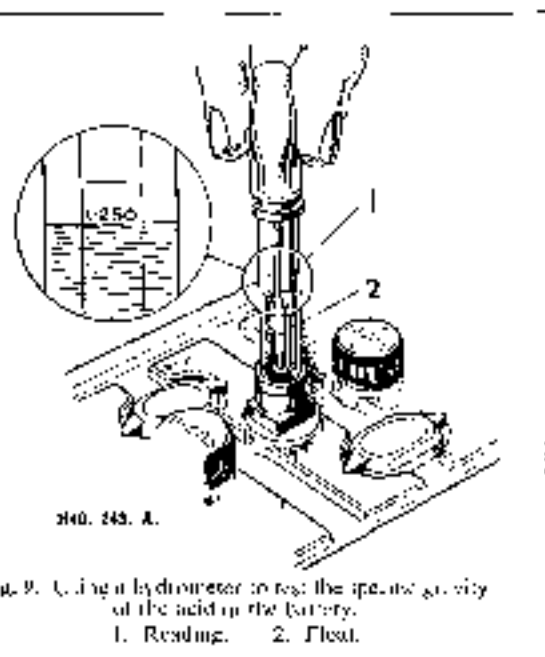

The specific gravity of the electrolyte in a cell of serviceable condition will rise during a charging, and fall during discharging period.

Specific gravity readings and their indications are: 1.280-1.300 Battery fully charged. About 1.210 Battery about half discharged. Below 1.150 Battery fully discharged. These figures are given assuming an electrolyte temperature of 60 F. (15.6°C.) If the electrolyte temperature exceeds this, .002 must be added to hydrometer readings for each 5°F. (2.8°C.) rise to give the true specific gravity at 60°F. Similarly, .002 must be subtracted from hydrometer readings for every 5°F. below 60 F.

The readings for all cells should be approximately the same. If one cell gives a reading very different from the rest, it may be that acid has been spilled or has leaked from this particular cell or there may be a short circuit between the plates.

When taking specific gravity readings, examine the condition of the electrolyte in the hydrometer. It should be fairly clear. If it is very dirty, it is possible that the plates are in a bad condition. In either of the above cases of failure, the battery should be sent to a Lucas Service Depot or Agent for overhaul.

Never leave the battery in a discharged condition for any length of time. Have it fully charged and every fortnight give it a short refreshing charge to prevent any tendency for the plates to become permanently sulphated.

### "Dry-charged" batteries

Some exported cars may be supplied with GT77A "Dry-charged" batteries. These batteries are prepared for service by carefully breaking the cells seals and filling to the top edge of the separators with electrolyte of the correct specific gravity, as described below. The battery will then be 90 per cent charged and capable of giving a starting discharge after a one-hour soaking period. A short refreshing charge of not more than four hours duration at the normal recharge rate of 4 amperes will ensure that the battery is fully charged. Maintenance in service is exactly as described for the GT77A battery.

### Specific Gravity of Electrolyte

The specific gravity of the electrolyte for filling the cells depends on the ambient temperature. Where this is normally below 90°F. (32°C.), the filling acid should be of 1.275 s.g., whilst at the completion of the charge a hydrometer reading should show 1.280-1.300. For temperatures frequently above 90°F. the filling acid should be of 1.215 s.g. rising to 1.220-1.240 at the completion of the charge.

Dilute sulphuric acid solution of s.g. 1.275 can be prepared by pouring slowly 1 part (by volume) of concentrated sulphuric acid into 2.9 parts of distilled water, and acid of s.g. 1.215 by adding 1 part of concentrated acid to 4 parts of distilled water. A glass, lead, or earthenware vessel should be used and the mixture well stirred. Both mixture and battery should be at ambient temperature before filling the cells. N.B. Never add the water to the acid, as the resulting chemical reaction may have dangerous consequences.

### DYNAMO

The dynamo is of the compensated voltage control type and its output is automatically controlled by a regulator unit which is housed along with the cut-out in the control box.

Inspect the dynamo driving belt and if necessary adjust by turning the dynamo on its mounting to take up any undue slackness. Care should be taken to avoid overtightening the belt and to see that the machine is properly aligned, otherwise undue strain will be thrown on the dynamo bearings.

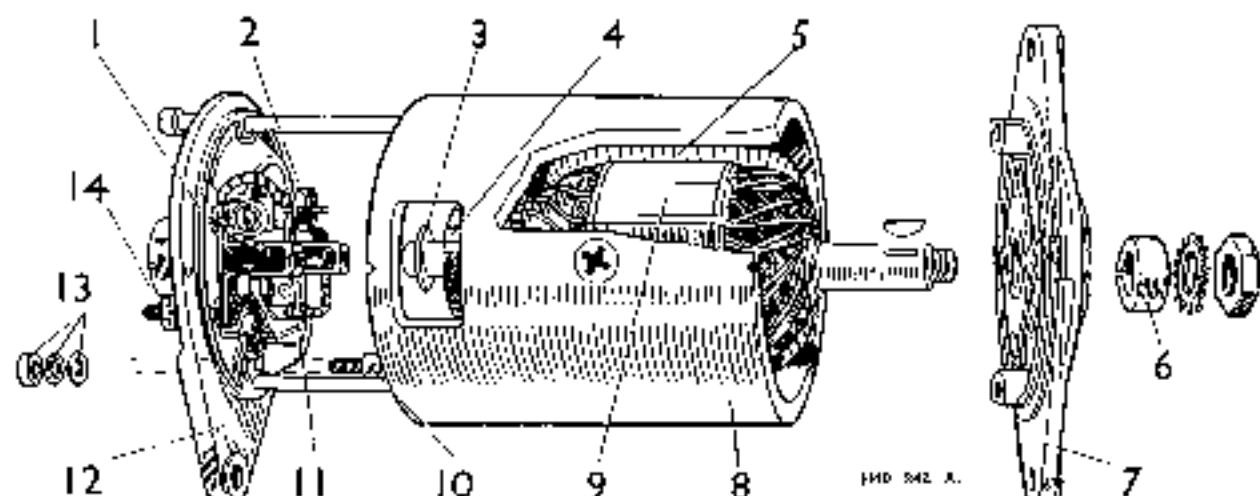

Fig. 10. The dynamo in exploded form.

- |                   |                         |                                      |
|-------------------|-------------------------|--------------------------------------|
| 1. Brush.         | 6. Distance collar.     | 11. Brush holder.                    |
| 2. Brush spring.  | 7. Driving end bracket. | 12. Commutator end bracket.          |
| 3. Thrust collar. | 8. Yoke.                | 13. Field terminal nuts and washers. |
| 4. Commutator.    | 9. Armature.            | 14. 'O' Terminal.                    |
| 5. Field Cast.    | 10. Field terminal.     |                                      |

The dynamo requires no other attention during normal service except for lubrication as described under "Every 12,000 miles".

#### Brushgear and Commutator

When the car is undergoing overhaul, say after 50,000 miles, the brushgear and commutator should be examined. To do this, dismantle the dynamo as described below.

Check that the brushes move freely in their holders, by holding back the brush springs and pulling gently on the flexible connectors. If a brush is inclined to stick, remove it from its holder and clean its sides with a petrol-moistened rag. Be sure to replace the brushes in their original position to retain the "berking".

If the brushes are worn so that they do not make good contact on the commutator or if the brush flexible is exposed on the running face, take out the screw securing the eyelet on the end of the brush flexibles, hold back the springs, and remove the brushes. Fit new brushes into the holder and secure the eyelets on the ends of the brush leads in the original positions. Brushes are preformed and do not require bedding.

Examine the commutator. It should have a bright, burnished appearance and be free from oil or dirt. If it is dirty, clean it with a rag moistened in petrol. If, however, the commutator is in a very bad condition, it should be cleaned with very fine glass paper and afterwards the insulators between the segments should be very carefully undercut to a depth of 1/32-in. with a back-saw blade ground down to the thickness of an insulator.

#### Removing the Dynamo

First disconnect the leads from the D and F terminals of the dynamo and then remove the dynamo fan. Release the two ring bolts holding the dynamo to the crankcase and water pump, together with the nut and setpin holding the adjusting link. Note that the three nuts concerned are of a self-locking type.

#### Dismantling the Dynamo

Take off the driving pulley. Remove the cover band, hold back the brush springs and remove the brushes from their holders.

Remove the nut, spring washer and flat washer from the smaller terminal (i.e. field terminal).

Unscrew the two through bolts at the commutator end, and remove bracket from dynamo yoke. The driving end bracket together with the armature can now be removed from the dynamo yoke. Reassembly of the dynamo is a reversal of the dismantling operations.

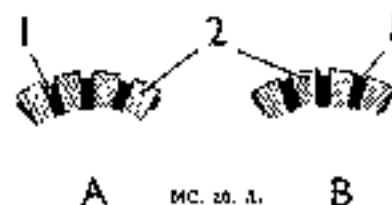

Fig. 11. Undercutting the commutator. A is the correct and B the wrong method. 1. Insulation. 2. Segments.



### Ammeter Readings

When noting ammeter readings, it must be remembered that during daytime running when the battery is in good condition, the dynamo gives only a trickle charge so that the charge reading will seldom be more than a few amperes.

A discharge reading may be given immediately after switching on the headlights. This usually happens after a long run, when the voltage of the battery is high. After a short time, the battery voltage will fall, and the regulator will respond, causing the dynamo output to balance the load.

When starting from cold, the charging current will rise until it reaches a steady maximum at a speed of say, 20 m.p.h. (32 k.p.h.), after which it will remain fairly high for about 10 minutes and then fall to a steady charge which is most suitable for the particular state of charge of the battery.

It will be noticed from the ammeter readings, that the dynamo does not charge at very low engine speeds. This is because it is not rotating fast enough to generate energy to charge the battery. The cut-out, which is an automatic switch and allows the flow of current from the dynamo to the battery only, is connected between the dynamo and the battery. It closes when the dynamo is rotating fast enough to charge the battery and opens when the speed is low or the engine is stationary, thus preventing current from flowing from the battery through the dynamo windings.

### CONTROL BOX

This unit contains the cut-out and voltage regulator. The regulator controls the dynamo output in accordance with the load on the battery and its state of charge. When the battery is discharged, the dynamo gives a high output, so that the battery receives a quick recharge, which brings it back to its normal state in the minimum time.

On the other hand, if the battery is fully charged the dynamo is arranged to give only a trickle charge, which is sufficient to keep it in good condition without any possibility of causing damage to the battery by overcharging.

The regulator also causes the dynamo to give a controlled boosting charge immediately after starting up, which quickly restores to the battery, the energy taken from it when starting. After about 30 minutes running, the output of the dynamo has fallen to a steady rate best suited to the particular state of charge of the battery.

The cut-out is an automatic switch for connecting

and disconnecting the battery with the dynamo. This is necessary because the battery would otherwise discharge through the dynamo when the engine is stopped or running at a low speed.

### Regulator Adjustment

The regulator is carefully set before leaving the works to suit the normal requirements of the standard equipment, and in general it should not be necessary to alter it. If, however, the battery does not keep in a charged condition, or if the dynamo output does not fall when the battery is fully charged, it may be advisable to check the setting and if necessary to readjust.

It is important, before altering the regulator setting, when the battery is in a low state of charge, to check that its condition is not due to a battery defect or to the dynamo belt slipping.

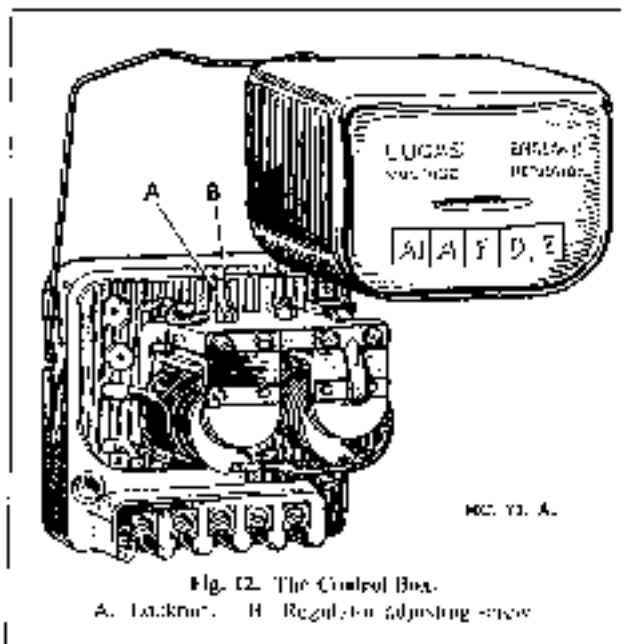

Fig. 12. The Control Box.  
A. Locknut. B. Regulator adjusting screw

### Checking and Adjusting the Electrical Setting

The regulator setting can be checked without removing the cover of the control box.

Withdraw the cables from the terminals marked "A" and "A1" at the control box and join them together. Connect the negative lead of a moving coil voltmeter (0-20 volts full scale reading) to the "D" terminal on the dynamo and connect the other lead from the meter to a convenient chassis earth.

Slowly increase the speed of the engine until the voltmeter needle "flicks" and then steadies; this should occur at a voltmeter reading between the limits given overleaf for the appropriate temperature of the regulator.

Setting Temperature	Voltmeter Reading
10 deg. C. (50 deg. F.)	16.1 16.7
20 deg. C. (68 deg. F.)	15.8 16.4
30 deg. C. (86 deg. F.)	15.6 16.2
40 deg. C. (104 deg. F.)	15.3 15.9

If the voltage at which the reading becomes steady occurs outside these limits, the regulator must be adjusted.

Shut off the engine, remove the control box cover, release the locknut (A) Fig. 72 holding the adjusting screw (B) and turn the screw in a clockwise direction to raise the setting or in an anti-clockwise direction to lower the setting. Turn the adjustment screw a fraction of a turn and then tighten the locknut.

When adjusting, do not run the engine up to more than half throttle because, while the dynamo is on open circuit, it will build up to a high voltage if run at a high speed and in consequence a false voltmeter reading would be obtained.

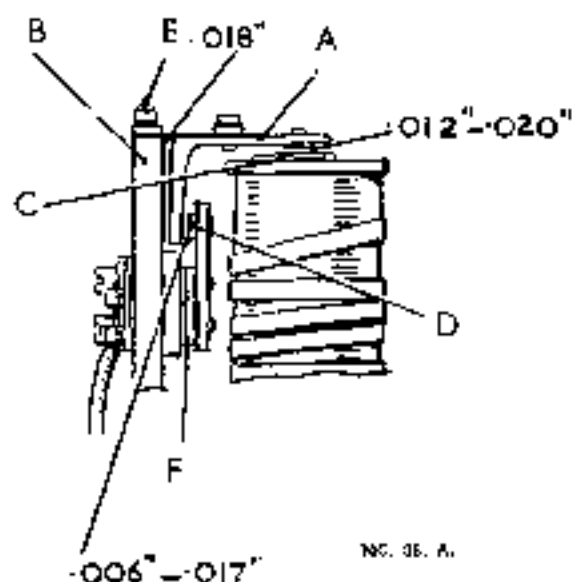

Fig. 13. Regulator mechanical setting.

- |                            |                     |
|----------------------------|---------------------|
| A. Adjuster.               | B. Regulator frame. |
| C. Bobbin case.            | D. Fixed contact.   |
| E. Armature fixing screws. | F. Packing shims.   |

### Mechanical Setting

The mechanical setting of the regulator is accurately adjusted before leaving the works, and provided the armature carrying the moving contact is not removed, the regulator will not require mechanical adjustment. If, however, the armature has been removed from the regulator for any reason, the contacts will have to be reset. To do this proceed as follows:—

- Slacken the two armature fixing screws (E) Fig. 13. Insert .018-in. (.4572 mm.) feeler gauge between back of the armature "A" and the regulator frame.
- Press back the armature against the regulator frame and drive on to the top of the bobbin core with the gauge in position, and lock the armature by tightening the two fixing screws.
- Check the gap between the underside of the arm and the top of the bobbin core, this should be .012-.020-in. (.3048-.508 mm.). If the gap is outside these limits, correct them by adding or removing shims (F) at the rear of the fixed contact.
- Remove the gauge and press the armature down, when the gap between the contacts should be .006-.017-in. (.1524-.4318 mm.).

### Cleaning the Contacts

To render the regulator contacts accessible for cleaning, slacken the securing plate carrying the fixed contact in order that the contact plate may be swung outwards. Clean the contacts by means of a fine emery cloth or fine emery stone or fine emery cloth. Carefully wipe away all traces of dirt or other foreign matter before finally tightening the securing screws.

### Cut-Out Adjustment

#### Electrical Setting

If the regulator setting is within the correct limit, but the battery is still not receiving current from the generator, the cut-out may be out of adjustment, or there may be an open circuit in the wiring of the cut-out and regulator unit.

Remove the cable from the terminal marked A on the control box (ensuring that the bare end does not come into contact with the chassis). Remove the voltmeter lead from the D terminal of the unit and connect it to terminal A. Run the engine as before; at a fairly low engine speed, the cut-out should operate, when a voltmeter reading should be given of the same value as that when the voltmeter was connected to terminal D.

If there is no reading, the setting of the cut-out may be badly out of adjustment and the contacts not closing. To check the voltage at which the cut-out operates, remove the control box cover, and connect the voltmeter between the D terminal and earth. Start the engine and slowly increase its speed until the cut-out contacts are seen to close, noting the voltage at which this occurs.

This should be 12.7-13.3 volts.

If operation of the cut-out takes place outside these limits, it will be necessary to adjust. To do this, slacken the locknut on the cut-out adjustment screw and turn the screw in a clockwise direction to raise the voltage setting, or in an anti-clockwise direction to

reduce the setting, testing after each adjustment by increasing the engine speed until the cut-out is seen to operate, and noting the corresponding voltmeter reading. Tighten the locknut after making the adjustment.

#### Mechanical Setting

As in the case of the regulator, adjustment of the mechanical setting of the cut-out should not be necessary in normal service. If for any reason the cut-out armature has to be removed from the frame, care must be taken to obtain the correct gap setting on reassembly.

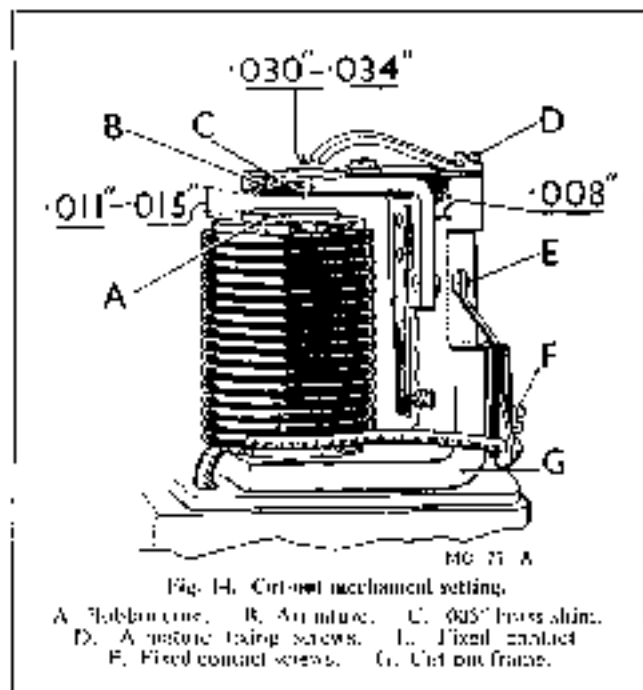

Fig. 14. Cut-out mechanical setting.

A. Tabular core. B. Armature. C. .005" brass shim.  
D. Armature fixing screws. E. Fixed contact.  
F. Fixed contact screws. G. Cut-out frame.

Slacken the two armature fixing screws and also the two screws securing the fixed contact.

Insert a .008-in. (.2032 mm.) gauge between the back of the armature and the cut-out frame, and a .011-.015-in. (.2794-.381 mm.) gauge between the core face and the armature. (A .005-in. (.127 mm.) brass shim is fitted to the underside of the armature, and the gap must be measured between the core face and the underside of the shim.)

Press the armature down and back against the two gauges and tighten the armature fixing screws.

With the gauges still in position, set the gap between the armature and the top plate arm to .030-in.-.034 in. (.762-.8636 mm.).

Remove the gauges and tighten the screws securing the fixed contact. Insert a .025-in. (.635 mm.) gauge between the core face and the armature.

Press the armature down on to the gauge. The gap between the contacts should now measure .002-in.-.008-in. (.0508-.1524 mm.).

Adjust the gap, if necessary, by adding or removing shims beneath the fixed contact plate.

#### Cleaning the Contacts

If the cut-out contacts appear burnt or dirty, place a strip of fine glass paper between the contacts—then, with the contacts closed by hand, draw the paper through. This should be done two or three times with the rough side towards each contact.

#### FUSE UNIT

##### Fuse marked "A1-A2"

This fuse protects these accessories which operate irrespective of the ignition being on or off. The interior light, radio and dual wind-on horns are in this category.

##### Fuse marked "A3-A4"

This fuse protects the accessories which are connected so that they operate only when the ignition is switched on, such as petrol gauge, trafficators, stop lamp, and wind-screen wipers.

The units which are protected by the fuse can readily be identified by referring to the wiring diagram.

A blown fuse is indicated by the failure of all the units protected by it, and is confirmed by examination of the fuse, which can easily be withdrawn from the spring clips in which it fits. If it has blown, the broken ends of the wire will be visible inside the glass tube. Before replacing a blown fuse, inspect the wiring of the units that have failed for evidence of a short circuit, or other faults which may have caused the fuse to blow and remedy the cause of the trouble.

It is important to use only the correct replacement fuse. The fusing value is marked on a coloured paper slip inside the glass tube of the fuse.

#### STARTER

The starter is a high speed motor fitted with a pinion, which is mounted on a quick start threaded sleeve. The pinion engages with a toothed ring fitted to the engine flywheel. The operating switch is mounted on the scuttle.

The following points should be observed when starting the engine:—

- (1) See that the controls are properly set.
- (2) Operate the starter switch firmly and release it as soon as the engine fires.
- (3) Do not operate the starter when the engine is running. If the engine will not fire at once, allow it to come to rest before operating the switch again.
- (4) Do not run the battery down by repeatedly operating the starter when the engine will not start.

The starter requires no attention during normal operation.

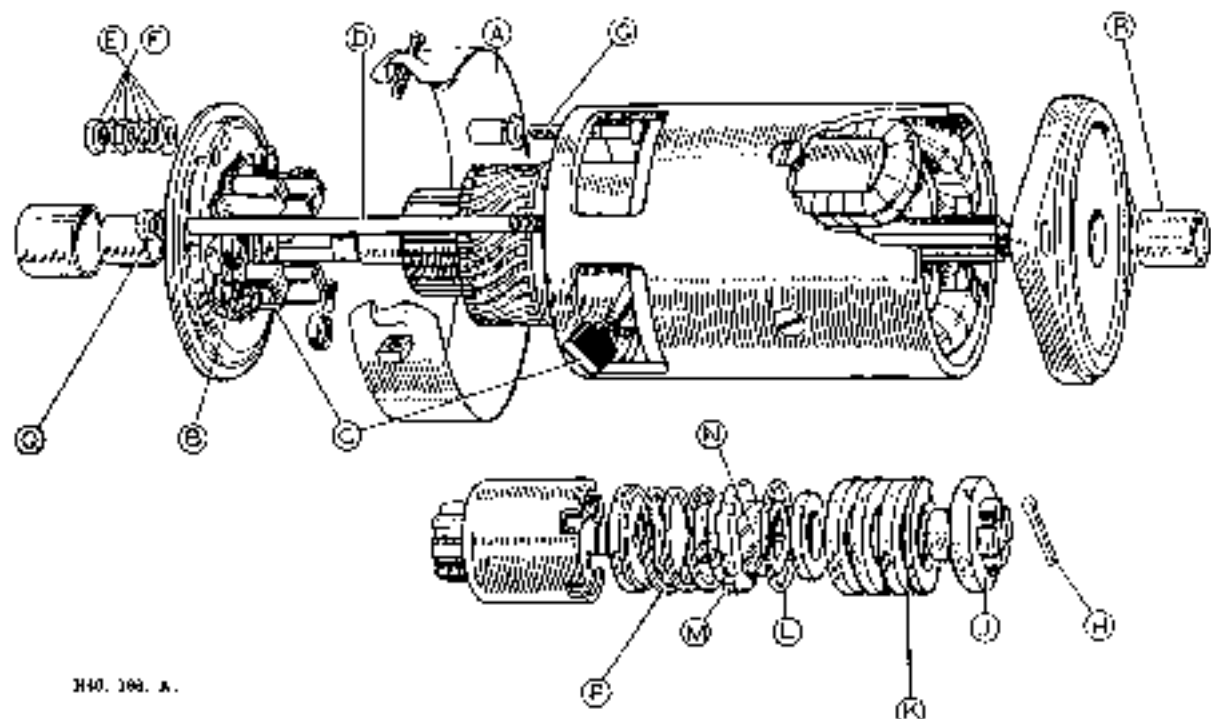

H40, 188, A.

Fig. 15. The starter in exploded form.

A. Cover band,  
 B. Brush spring  
 C. Brushes.  
 D. Through hole.  
 E. Terminal nuts.

F. Terminal washers.  
 G. Terminal post.  
 H. Spur pin.  
 J. Shaft nut.  
 K. Main spring

L. Retaining ring.  
 M. Control nut.  
 N. Sleeve.  
 O. Restraining spring.  
 P. Driving bush.  
 R. Bearing bush.

### Testing on the vehicle

In the following test it is assumed that the battery is in a charged condition.

Switch on the lamps and operate the starter control. If the lights go dim, but the starter is not heard to operate, an indication is given that the current is flowing through the starter motor windings but that for some reason the armature is not rotating; possibly the starter pinion is meshed permanently with the geared ring on the flywheel. This could be caused by the starter being operated while the engine is still moving. In this case, the starter switch must be removed from the engine for examination. Should the lamps retain their full brilliance when the starter switch is operated, check that the switch is functioning (see page Q113). Next, if the switch is in order, examine the connections at the battery, starter switch, and starter, and also examine the wiring joining these units. Continued failure of the starter to operate indicates an internal fault in the starter which must be removed for examination.

Sluggish or slow action of the starter is usually caused by a poor connection in the wiring which causes

a high resistance in the starter circuit. Check the wiring as described above.

### Normal Service

If any difficulty is experienced with the starter not meshing correctly with the flywheel, it is probably that the presence of dirt on the starter drive is preventing the free movement of the pinion and barrel assembly on its sleeve and the sleeve and pinion should be washed with paraffin. Alternatively, the drive may have been damaged owing to mis-use.

In the event of the starter pinion becoming jammed in the mesh with the flywheel, it can usually be freed by turning the starter armature by means of a spanner applied to the shaft extension at the commutator end. This is accessible by taking off the cap.

### Removing the Starter from the Engine

When the car is undergoing a general overhaul, say after 50,000 miles (80,000 km.), the commutator and brushgear should be examined. It is advisable to remove the starter from the engine.

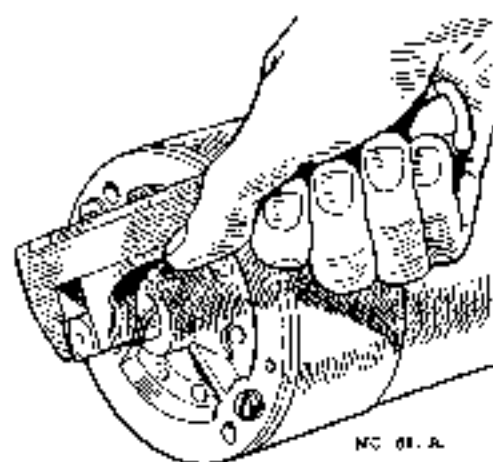

Fig. 16. Turning the squared end of the shaft to free a jammed starter.

The earthing cable (positive) should be disconnected from the battery terminal to avoid any danger of causing a short circuit, and then remove the connections at the starter.

#### Dismantling the Starter Drive

If it is found that parts of the drive are worn or damaged they must be replaced. The drive is dismantled by first removing the cotter pin from the nut at end of shaft.

Unscrew the nut (R.H. thread) and take off the main spring.

The complete drive can now be removed from the splined shaft by pulling it off with a rotary movement. Unscrew the screwed sleeve from the barrel assembly.

Further dismantling of the barrel assembly is carried out by removing the large retaining ring.

*Note:* If the screwed sleeve is worn or damaged it is essential that it is replaced, together with the control nut.

Reassemble by reversing the above procedure.

#### Dismantling the Starter Motor

Take off the cover band at the commutator end, hold back the brush springs and take out the brushes from their holders.

Remove the terminal nuts and washers from the terminal post on the commutator end bracket. Unscrew and withdraw the two through-bolts and take off the commutator end bracket.

Remove the driving end bracket complete with armature from the starter yoke.

Reassemble by reversing the above procedure.

#### Commutator

Examine the commutator and if burred or blackened, clean with a petrol-moistened rag, or if in bad condition carefully polish with very fine glass paper.

*Note:* The insulators in the starter commutator must not be undercut.

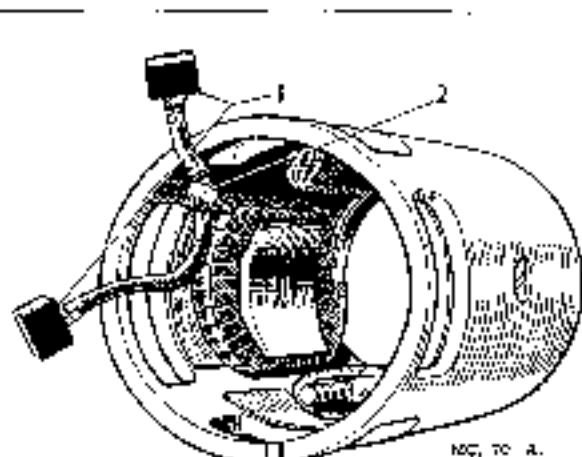

Fig. 18. Starter yoke.

1. Brushes.
2. Tapping on field coil.

#### Brushgear

Next examine the brushes; check that they move freely in their holders by holding back the brush springs and pulling gently on the flexible connectors.

If a brush is inclined to stick, remove it from its holder and clean its sides with a petrol moistened cloth. If the brushes are worn so that they do not make good contact on the commutator or if the brush flexible is exposed on the running face, they must be replaced.

The flexible connectors must be removed by unsoldering and the connectors of the new brushes secured in their places by soldering. The brushes are preformed so that bedding to the commutator is unnecessary.

#### Starter Switch—Testing in Position

Connect a 12-volt supply with a test lamp in series with the battery side terminal of the starter switch and a

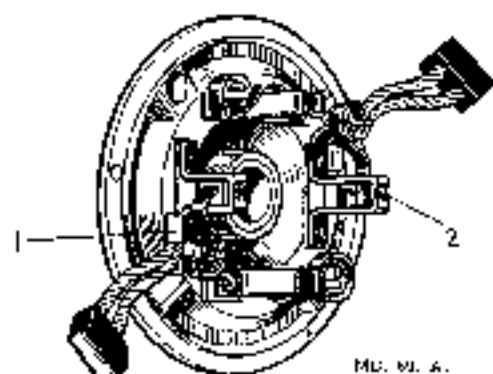

Fig. 17. Commutator end bracket.

1. Terminal eyelet
2. Brush holder.

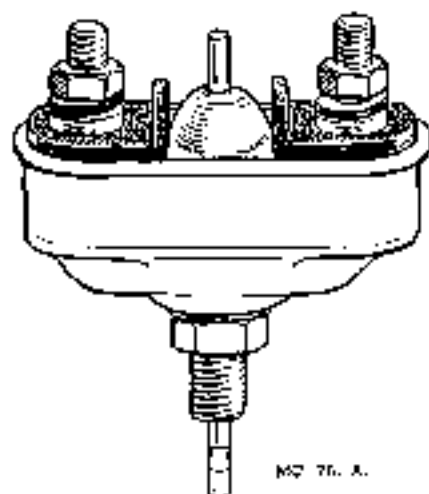

Fig. 19. The starter switch.

good earthing point. If the lamp lights, the cable to the starter switch is in order. Operate the switch and test between the other terminal of the starter switch and earth. If the lamp does not light starter switch is faulty and must be replaced as a complete unit.

### IGNITION

**Distributor:** At slow engine speeds the ignition is slightly retarded, but at high speeds it is advanced by an automatic timing control mechanism working under centrifugal force.

A vacuum-operated timing control is also fitted, designed to give additional advance under part-throttle conditions.

The combined effects of the centrifugal and vacuum operated timing controls gives added efficiency over the full operating range of the engine, with a corresponding economy in fuel consumption.

A micrometer adjuster is also provided so that fine adjustments to timing can be made to allow for changes in running conditions, e.g. state of carbonisation, change of fuel, etc.

The capacitor connected in parallel with the contact breaker points is of the metalised paper type and has the property of being self-healing in the event of dielectric breakdown.

A measure of radio and television interference suppression is provided by the carbon brush that forms the connection to the rotating electrode of the distributor. This brush has the effect of a suppression resistor in the lead from the coil to the distributor.

**Coils:** The ignition coil requires no attention beyond seeing that the terminal connections are tight, and that the exterior is kept clean, particularly between the terminals.

**I.T. Cables:** The high tension cables must be carefully examined, and any which have the insulation cracked, perished or damaged in any way, must be replaced by 7 mm. rubber covered ignition cable.

The method of connecting the cables to the coil is to thread the knurled moulded nut over the cable, bare the end of the cable for about  $\frac{1}{2}$ -in. (6.35 mm.), thread the wire through the washer removed from the end of the original cable and bend back the wire strands. Screw the nut into its terminal.

Fig. 20. Distributor in exploded form.

- 1 Cover.
- 2 Carbon brush.
- 3 Retor.
- 4 Contact breaker points.
- 5 Contact breaker plate washer.
- 6 Jump ring.
- 7 Vacuum control.
- 8 Distance collar.
- 9 Balance weights.
- 10 Cam.
- 11 Contact breaker plate tension spring.
- 12 Capacitor.

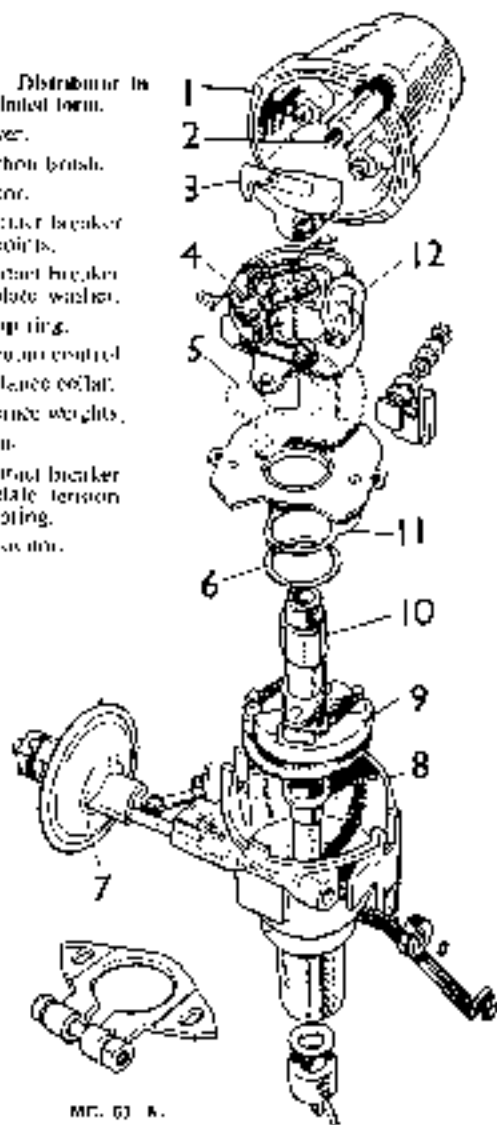

The cable is connected to the distributor by unscrewing the pointed fixing screws on the inside of the moulding, pushing the cables, which should not be bared but cut off flush to the required length, well home into their respective terminals and tightening the pointed fixing screws.

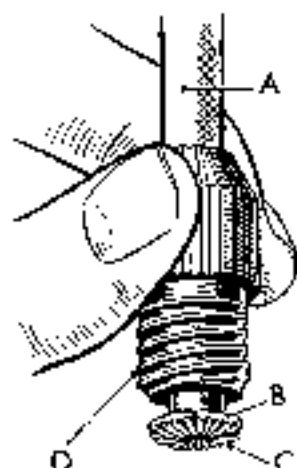

MO. 28. A.

Fig. 21. Fitting a high tension cable terminal.

A. Cable. B. Washer. C. Cable strands.  
D. Moulded terminal

### ELECTRIC HORN

All horns, before being passed out of the works, are adjusted to give their best performance and will give a long period of service without any attention; no subsequent adjustment is required.

If one of the horns fails or becomes uncertain in its action, it does not follow that the horn has broken down. First ascertain that the trouble is not due to some outside source such as a loose or broken connection in the wiring of the horn or a discharged battery; a short circuit in the horn wiring will cause the fuse to blow. If both horns fail or become uncertain in action, the trouble is probably due to a blown fuse or discharged battery. If the fuse has blown, examine the wiring for the fault and replace with the spare fuse provided.

#### Tune Adjustment

It is also possible that the performance of a horn may be upset by the fixing bolt working loose, or by some component near the horn being loose. If after carrying out the above examination the trouble is not rectified, the horn may need adjustment, but this should not be necessary until the horns have been in service for a long period.

Adjustment does not alter the pitch of the note, it merely takes up wear of moving parts. When adjusting the horns, short circuit the fuse, otherwise it is liable to blow. Again, if the horns do not sound on adjustment, release the push instantly.

When making adjustments to a horn, always disconnect the supply lead of the other horn, taking care to ensure that it does not come into contact with any part of the chassis and so cause a short circuit.

Remove the fixing screw from the top of the horn and take off the cover. Detach the cover securing bracket by springing it out of its location.

Using a pair of 4 B.A. spanners, slacken the lock-nut below the fixed contact and rotate the adjusting nut until the contacts are just separated. Then turn back the adjusting nut about half a turn and measure the current taken by the horn when the horn push is operated. This current should be between six and seven amperes. If this value is not measured, continue to re-adjust and test, turning the adjusting nut in a clockwise direction to decrease the current and in an anti-clockwise direction to increase the current.

### TRAFFICATORS

The Lucas "Trafficator" is a solenoid-operated unit (see Fig. 23). When the switch on the steering column is moved to the left or right, the appropriate indicator arm is raised and the bulb, which is incorporated in the arm of the indicator, automatically illuminates the arm.

In order to raise the arm of the indicator for replacement of a bulb or lubricating, switch on the Trafficator and then supporting the arm in a horizontal position, move the switch to the "off" position.

#### Replacement of a Bulb

Withdraw the screw at the end of the arm and lift the metal plate; the burnt out bulb may then be replaced. Lower the plate and secure it by means of its fixing screw.

The replacement bulb is a Lucas No. 256, 12 volt, 3 watt, festoon.

### WINDSCREEN WIPER

The windscreen wiper consists of an electric motor and gearbox mounted on the engine side of the bulkhead

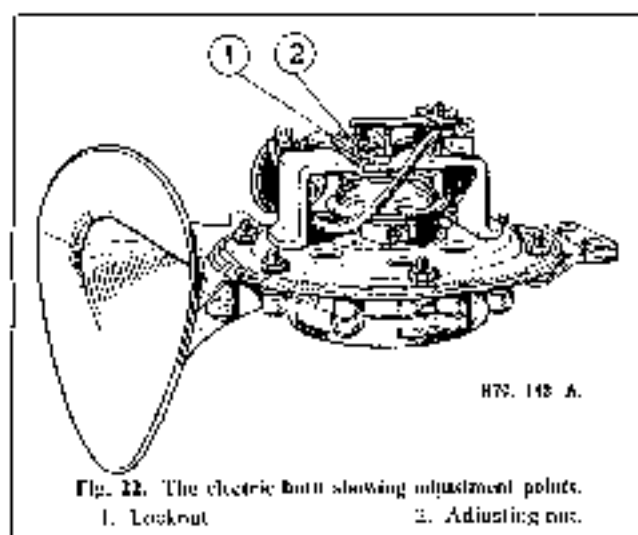

872. 148. A.

Fig. 22. The electric horn showing adjustment points.

1. Lockout 2. Adjusting nut.

**Replacement of Blade**

To remove the blade, pull the arm away from the windscreen and disengage the blade by swivelling it upwards.

To clip the new blade in position, insert the curved "wrist" at the end of the arm into the slot in the back of the blade.

**IGNITION AND WARNING LIGHT**

The ignition switch, besides forming a means of stopping the engine, is provided for the purpose of preventing the battery being discharged by the current flowing through the coil windings when the engine is stopped. A warning lamp is provided on the instrument panel which gives a red light when the ignition is switched on and the engine is running very slowly or is stationary, thus reminding you to switch off.

Should the warning lamp bulb burn out, this will not in any way affect the ignition system, but you should renew it as soon as possible in order to safeguard your battery.

The replacement bulb is a Lucas No. 987.

**LIGHTING****Headlamps**

Each headlamp incorporates a Lucas Light Unit, which consists essentially of a reflector and front glass assembly provided with a mounting flange by means of which it is secured in the body housing. The bulb, which has a Lucas "pre-focus" cap, is located accurately in the reflector and is secured by a bayonet-fixed back-shell which also provides the contact to the bulb. The design of the bulb and its holder is such that the bulb is correctly positioned in relation to the reflector and no focusing is required when a replacement bulb is fitted.

Cars are fitted with double filament bulbs in both headlamps, thus providing either a main driving light or beams that are dipped.

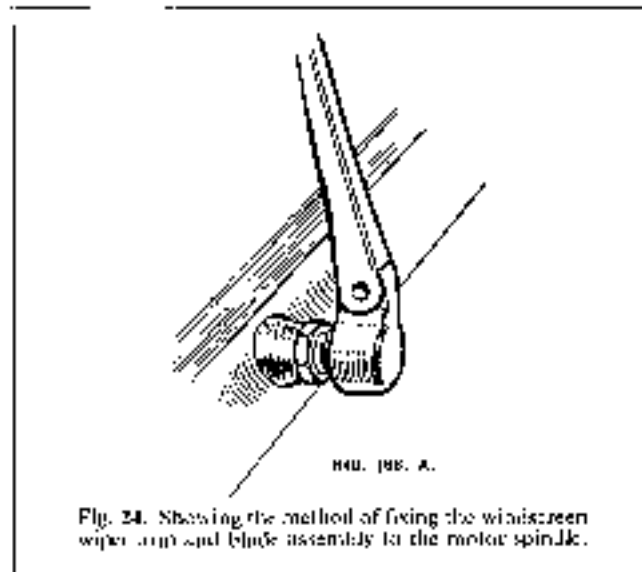

Fig. 24. Showing the method of fixing the windscreen wiper arm and blade assembly to the motor spindle.

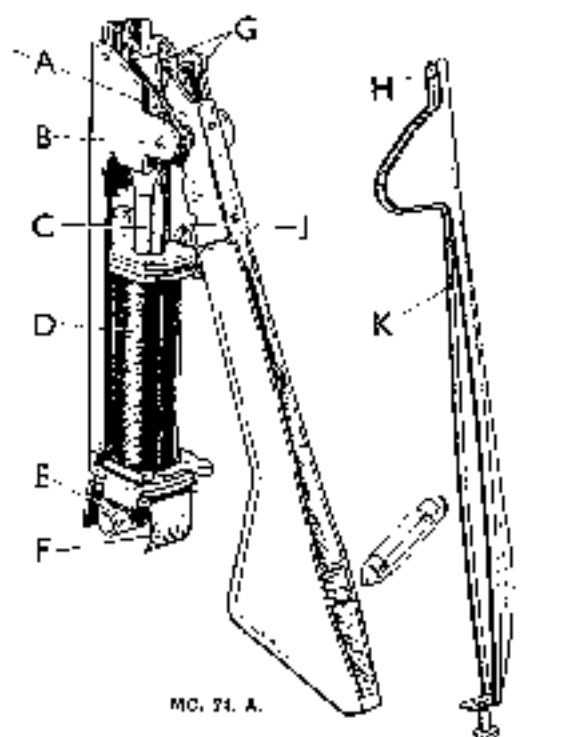

Fig. 23. The Trafficator.

- |                     |                        |
|---------------------|------------------------|
| A. Arm catch pin.   | E. Buffer plate.       |
| B. Arm pivot.       | G. Bulb contact.       |
| C. Plunger.         | H. Securing tongue.    |
| D. Solenoid.        | J. Arm securing screw. |
| E. Terminal sleeve. | K. Arm cover.          |

and a flexible cable rack mechanism transmits motion from the motor to the wiper spindles at the bottom of the screen. The motor incorporates an overload protective device in the form of a thermostat which under conditions of excessive heating automatically cuts off the current supply to the motor until normal conditions are restored, when the wiper will automatically re-start. To start the wiper, gently pull outwards the wiper control switch on the instrument panel. To park, switch off by pressing the control switch inwards when the arms are at the end of the stroke. Do not try to push the arms across the windscreen by hand.

No adjustment or lubrication is necessary as the gears are fully lubricated before leaving the Works.

**Replacement of Arm and Blade Assembly**

The method of fixing the arm and blade assembly to the wiper spindle is illustrated in Fig. 24.

The screw securing the arm and blade assembly is designed so that it also takes the form of an extractor. To remove the arm and blade assembly slacken the fixing screw until the assembly is freed from the wiper spindle.



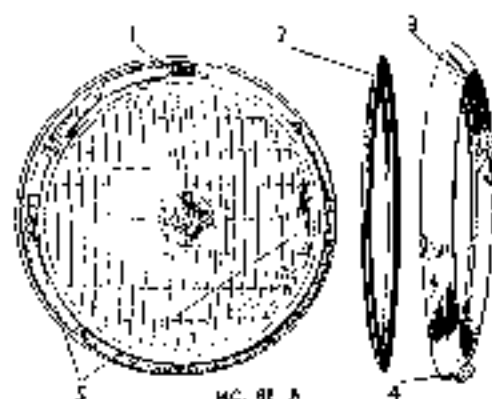

Fig. 25. Headlight glass assembly.

1. Vertical adjustment screw. 2. Rubber dust excluder. 3. Front rim. 4. Rim securing screw. 5. Horizontal adjusting screws.

### Removing the Light Unit for Bulb Replacement

Remove the front rim by unscrewing the rim securing screw and lifting off the rim. Next remove the dust excluding rubber, when three spring loaded adjustment screws will be visible. Press the Light Unit in against the tension of the adjustment screw springs and turn it in an anti-clockwise direction until the heads of the screws can be disengaged through the slotted holes in the Light Unit rim. Do not disturb the screws when removing the Light Unit as this will alter the lamp setting.

Twist the backshell in an anti-clockwise direction and pull it off. The bulb can then be removed.

Place the replacement bulb in the holder, taking care to locate it correctly. Engage the projections on the inside of the backshell with the slots in the holder, press on and secure by twisting it to the right.

Position the Light Unit so that the heads of the adjusting screws protrude through the slotted holes in the flange, press the Unit in and turn in a clockwise direction. Replace the dust excluding rubber so that its thicker inner edge rests in the recess around the Light Unit rim. Refit the front rim, locating the top of the rim first and securing by means of the fixing screw.

### Replacement of Light Unit

In the event of damage to either the front lens or reflector, a replacement Light Unit must be fitted.

- (1) Remove the Light Unit assembly as already described.
- (2) Withdraw the three screws from the unit rim and remove the seating rim and unit rim from Light Unit.

- (3) Position the replacement Light Unit between the unit rim and seating rim taking care to see that the die cast projection at the edge of the light fits into the slot in the seating rim and also that the seating ring is correctly positioned. Finally secure in position by means of the three fixing screws.

### Cars for Export to U.S.A.

In order to comply with Lighting regulations in certain States a sealed beam unit must be fitted in place of the Lucas Light Unit.

To make the conversion, proceed as follows:—

- (1) Remove the Light Unit from seating and unit rims as already described.
- (2) Remove the two packing clips from the slots in the seating rim.
- (3) Fit sealed Beam Unit in position taking care to locate it so that the three diecast projections on the unit locate in the slots in the seating rim.
- (4) Refit unit rim and secure in position by means of the three fixing screws.
- (5) Wiring. Connection to the Sealed Beam unit is made by means of a three-point adaptor plug. To make the connections, proceed as follows:—
  - (i) Remove the three cables from the back shell of the Light Unit and bare cables for approx.  $\frac{3}{8}$  in.
  - (ii) Remove the adaptor from the Sealed Beam Unit. *Note.* It will be observed that the rear of the adaptor is marked "Ground", "Pass" and "Drive".
  - (iii) Remove the three spring contacts from the adaptor.
  - (iv) Solder the core of the Black cable to one of the spring contacts and fit the contact in the recess of the adaptor marked "Ground".

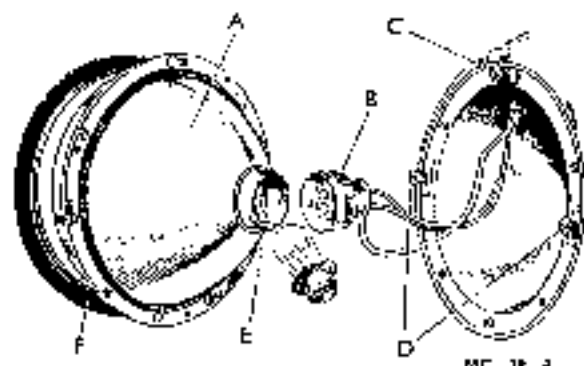
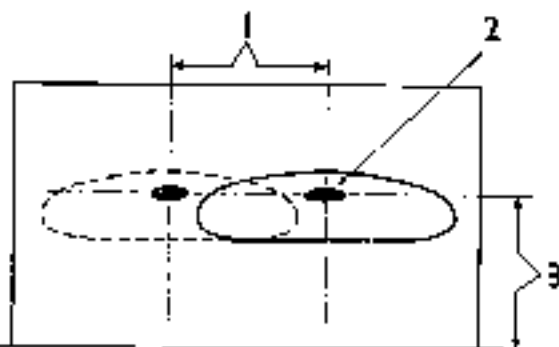

Fig. 26. Headlight unit.

- A. Light Unit; B. Backshell; C. Vertical adjustment; D. Horizontal adjustment; E. Bulb holder; F. Dust excluder.

- (v) Solder the core of the Red and Black cable to one of the remaining spring contacts and fit the contact in the recess of the adaptor marked "Pass".
- (vi) Solder the core of the Blue cable to the remaining spring contact and fit the contact in the recess of the adaptor marked "Drive".
- (vii) Finally fit the sealed beam unit assembly to the lamp body, as already described.



MC. 64 A.

Fig. 23. Headlamp beam setting.

1. Distance between lamp centres. 2. Concentrated area of light. 3. Height of lamp centres from ground.

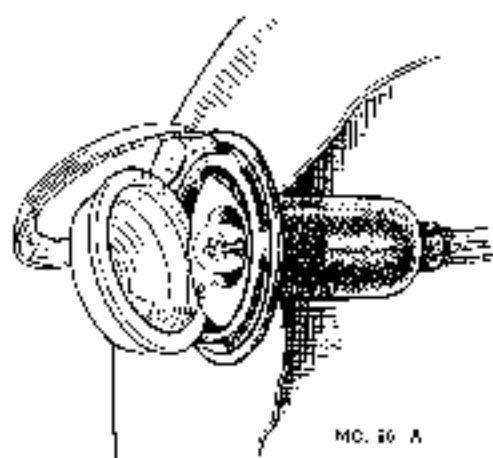
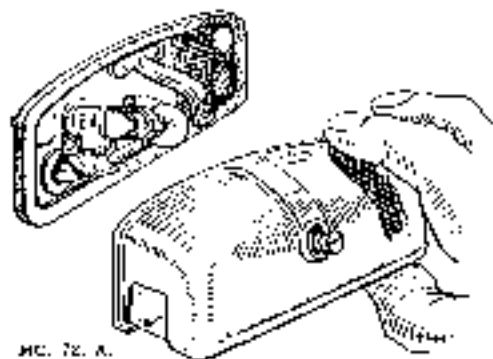

Fig. 25. Removal of the glass of the stop-tail lamp.

#### Stop-Tail (Lucas Model 488)

To gain access to the bulb, pull back the outer rubber lip to release the rim and the inner rubber lip to release the lens.

Remove the defective bulb and replace with type listed on page Q/1. (This bulb is manufactured with off-set securing pins, thus ensuring that the bulb is fitted into the holder the correct way round.) First, fit the lens and secondly, the rim to the inner and outer rubber lips respectively.



MC. 72 A.

Fig. 29. Number plate illumination.

#### Number Plate Lamp (Lucas Model 467)

To gain access to the bulb, slacken the single securing screw and remove the front cover. Remove the defective bulb, see page Q/1 for replacement.

#### Cleaning Lamps

Chromium plated surfaces should be washed with plenty of water, and when the dirt is completely removed, they must be polished with a chamois leather or soft dry cloth. Do not use metal polishes on chromium plating.

#### Setting

The lamps should be set so that the main driving beams are straight ahead and parallel with the road surface and with each other. If adjustment is required, remove the rim as described in page Q/17. Set each lamp to the correct position in the vertical plane by means of the vertical adjustment screw at the top of the reflector unit. Turn the screw in a clockwise direction to raise the beam and in an anti-clockwise direction to lower it. Horizontal adjustment can be altered by turning the adjustment screws on each side of the Light Unit.

The setting of the lamps can be best carried out by placing the car in front of a blank wall at a distance of 25-ft. (7.62 m.), taking care, of course, that the surface on which the car is standing is level and not sloping relative to the wall. It will be found an advantage to cover one lamp while setting the other.

#### Side Lamps (Lucas Model 516)

To gain access to the bulb, slacken the screw at the rear of the lamp body when the front rim and bulb holder assembly may be withdrawn. Squeeze the legs of the lamp holder bracket together to release the rim, rubber washer, and lens. Remove the defective bulb and replace with the correct type, see page Q/1. Re-assembly is a reversal of the above instructions.

## LOCATION AND REMEDY OF FAULTS

Although every precaution is taken to eliminate all possible causes of trouble, failure may occasionally develop through lack of attention to the equipment, or damage to the wiring. The following pages set out the recommended procedure for a systematic examination to locate and remedy the causes of some of the more probable faults. The sources of many troubles are by no means obvious and in some cases a considerable amount of deduction from the symptoms is needed before the cause of the trouble is disclosed.

For instance, the engine might not respond to the starter switch, a hasty inference would be that the starter motor is at fault. However, as the motor is dependent on the battery, it may be that the battery is exhausted.

This, in turn, may be due to the dynamo failing to charge the battery, and the final cause of the trouble may be, perhaps, a loose connection in some part of the charging circuit.

If, after carrying out the examination, the cause of the trouble is not found, it is advisable to consult the nearest Lucas Service Depot or Agent.

### IGNITION CIRCUIT

#### 1. Engine will not fire

(a) See that the battery terminals are secure and that the battery is in a charged condition, either by use of a hydrometer or by checking that the starter will turn the engine and the lamps give a good light.

If the battery is discharged, it must be recharged from an independent electrical supply.

(b) See that the controls are correctly set for starting.

(c) Remove the cable from the centre distributor terminal and hold it so that the end is about  $\frac{1}{4}$ -in. away from some metal part of the chassis while the engine is turned slowly over. If sparks jump the gap regularly, the coil and distributor are functioning correctly, and the sparking plugs must be examined. If these are clean, and the gaps correct, the trouble is due to carburettor, petrol supply, etc.

(d) If the coil does not spark in test (c) check for a fault in the low tension wiring. This will be indicated by (i) no ammeter reading when the engine is slowly turned and the ignition switch is on, or

(ii) no spark occurring between the distributor contacts when quickly separated by the fingers when the ignition is switched on. Examine all cables in the ignition circuit and see that all connections are tight.

(e) If the wiring proves to be in order examine the distributor contacts, if necessary cleaning them and adjusting the gap as described on page O/1.

#### 2. Engine Mistires

(a) Examine the distributor contacts, if necessary cleaning them and adjusting the gap as described on page O/1.

(b) Run the engine at a fairly fast idling speed and short-circuit each plug in turn with, say, the blade of an insulated screwdriver, or with a hammer head placed across the plug terminal to contact the cylinder head.

Short-circuiting a defective plug will cause no noticeable change in the running note, whereas shorting out a sound plug will cause a pronounced increase in roughness.

(c) Having thus located the defective cylinder, stop the engine and remove the cable from the sparking plug terminal. Re-start the engine and hold the cable end about  $\frac{3}{8}$ -in. (4.7625 mm.) from the cylinder head. If the sparking is strong and regular, the fault lies with the sparking plug which should be removed, cleaned and adjusted, or replaced.

(d) If, however, there is no spark or only weak and irregular sparking, examine the cable from the plug to the distributor, renewing the cable if the rubber is cracked or perished. Clean the distributor moulded cover and check the free movement of the carbon brush. If this brush needs replacing see that the correct type is obtained; the standard non-resistive brush is too short for use with model DM2AH4 distributor and would not make contact with the rotating electrode. If tracking has occurred, indicated by a thin black line, usually between two or more electrodes, a replacement distributor cover must be fitted.

(e) If test (b) shows all four plugs to be sparking regularly, the trouble may be due to engine defects or to the carburettor, petrol supply, etc.

### CHARGING CIRCUIT

#### 1. Battery in a low state of charge

(a) This state will be shown by lack of power when starting, poor light from the lamps, and hydrometer readings below 1.200, and may be due to the dynamo either not charging or giving low or intermittent output. The ignition warning light will not go out if the dynamo fails to charge, or will flicker on and off in the event of intermittent output.

(b) Examine the charging and field circuit wiring, tightening any loose connection, or replacing broken cables. Pay particular attention to the battery connections.

(c) Examine the dynamo driving belt; take up any undue slackness by turning the dynamo on its mounting.

(d) If the cause of the trouble is not apparent, have the equipment examined by a Lucas Service Depot or Agent.

**2. Battery overcharged**

(a) This will be indicated by burnt-out bulbs, very frequent need for topping-up of battery, and high hydrometer readings. Check the ammeter readings when the car is running steadily with a fully charged battery and no lights or accessories in use, the charge reading should be of the order of only 2-4 amperes.

If the ammeter reading is in excess of the value, it is advisable to have the regulator setting tested, and adjusted if necessary by a Service Depot or Agent.

**STARTER MOTOR****1. Starter Motor lacks power or fails to turn engine**

(a) See if the engine can be turned over by hand. If not, the cause of the stiffness of the engine must be located and remedied.

(b) If the engine can be turned by hand, first check that the trouble is not due to a discharged battery.

(c) Examine the connections to the battery, starter and starter switch, making sure that they are tight and that the cables connecting these units are not damaged.

(d) It is also possible that the starter pinion may have jammed in mesh with the flywheel, although this is by no means a common occurrence. To disengage the pinion, rotate the squared end of the starter shaft by means of a spanner.

**2. Starter operates, but does not crank engine**

This fault will occur if the pinion and barrel assembly of the starter drive is not allowed to move along the

screwed sleeve into engagement with the flywheel, due to dirt having collected on the screwed sleeve. Clean the sleeve carefully with paraffin.

**3. Starter pinion will not disengage from flywheel when engine is running**

Start the engine, and see if the starter pinion is jammed in mesh with the flywheel, releasing it if necessary by rotation of the squared end of the starter shaft. If the pinion persists in sticking in mesh, have the equipment examined at a Service Depot. Serious damage may result to the starter if it is driven by the flywheel.

**LIGHTING CIRCUITS****1. Lamps give insufficient illumination**

(a) Test the state of charge of the battery, recharging if necessary either by a long period of daytime running or from an independent electrical supply.

(b) Check the setting of the lamps

(c) If the bulbs are discoloured as a result of long service, they should be replaced.

**2. Lamps light when switched on, but gradually fade out**

As para 1. (a).

**3. Brilliance varies with speed of car**

(a) As para. 1. (a).

(b) Examine the battery connections, making sure that they are tight, and replace faulty cables.





# BODYWORK

**T**HE careful maintenance of the bodywork, both internally and externally, is of primary importance if the car is to retain its appearance and comfort. The periodical attentions briefly indicated in the following paragraphs should therefore be undertaken as regularly as possible.

## Care of the Bodywork

### Enamel

The A40 bodies are finished in a synthetic enamel which gives a fine glossy finish to the bodywork. No additional polishing is required, but should there be a tendency for the paintwork to become dull after six to nine months' service, a light application of a good non-abrasive emulsion polish will immediately restore the original lustre.

Normal cleaning comprises washing the car down with clean running water and wiping away the surplus moisture with a clammy leather. Never "dry clean" the bodywork as the practice of removing dust or dirt with a dry cloth scratches the paintwork. Grease and oil splashes can be removed by gently rubbing with a petrol-moistened cloth.

Cellulose should not be used for touching-up purposes: synthetic enamel is obtainable from Austin Distributors.

### Chromium

Plated parts should be finished with a damp leather. If the chromium plate is very dirty it should be washed in warm soapy water, but on no account should metal polish be used.

### Door Locks and Hinges

Occasionally apply a few drops of oil on the moving parts of all door locks and hinges. A light touch of grease should be situated on the lock striker plates to ensure free movement and to reduce wear of the locks.

In addition the security of door hinges, locks,

doorcuffs and striker plates should be checked periodically with a screwdriver.

### Upholstery

The leather work has, in general, an impermeable surface which can be kept clean and fresh looking by an occasional wiping down with a damp cloth and saddle soap. Finish off with a good furniture cream when the surface is dry.

Grain, where used for upholstery, is best kept in good condition by lightly brushing or by use of a vacuum cleaner. Should the cloth become stained the task of cleaning is best undertaken by a firm of specialists.

### Seat Slides

Occasionally check the securing screws for tightness and apply a little grease to the runners on the floor beneath the seats. Carefully remove the surplus grease to avoid damage to carpets.

### Carpets

The carpets should be kept free from dust and grit by use of a vacuum cleaner or vigorous brushing with a stiff brush. Periodically the carpets and felts should be removed and thoroughly beaten, after which the body floor should be inspected.

Any parts of the body floor which shows signs of rust should be cleaned and then painted with a quick-drying enamel before the carpets are replaced.

### Windows

Window glasses and mirror should be cleaned with a damp leather.

## DISMANTLING AND ASSEMBLING BODY PARTS

### SALOON AND COLPÉ

#### Bonnet Top

The bonnet, at its rear edge, has two brackets which form part of the hinges. Two legs from the scuttle are secured to these brackets by two nuts and bolts each.

The bonnet opening has been described under the section called "Instruments and Controls".

#### Bonnet Surround and Grille

Before proceeding with the dismantling of the bonnet surround, the cables to the head lamps should be disconnected at their nearest snap connectors.

The bonnet surround is secured at each side to the fitch plate by three setpins and four nuts and bolts. Slacken the eight bolts and withdraw the six setpins together with two setscrews which, at the top centre of the panel, hold the panel to the scuttle. The surround can now be lifted clear of the bodywork thus giving admirable access to all engine details.

At the rear of the main grille there are ten studs which pass through the surround to be secured with spring clips. The vertical chrome bar is held in place by four setscrews. Each side grille is held in a similar manner to the main grille.

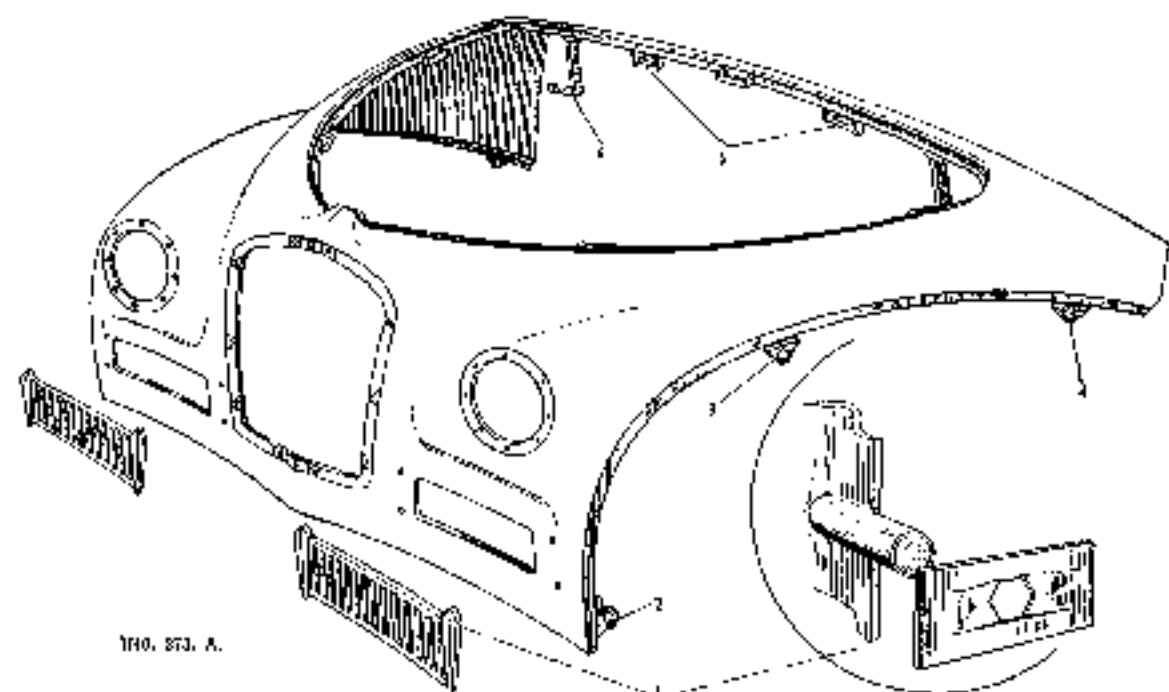

Fig. 1. The bonnet surround assembly showing: 1. The grille and its method of fixing. 2, 3, and 4. The side securing brackets. 5. The rear securing positions. 6. Bonnet top hinge.

### Front Wing and Baffles

Each front wing has its rear baffle plate welded to it, thus the dismantling of a wing from the body is quite simple. Six wing brackets are secured to the fitch plate by five bolts and one setpin. A set of seven setpins holds the baffle plate to the scuttle. Before the wing is removed from the bodywork, however, the side lamp cables must be released at their nearest snap connectors.

### Fitch Plate

Both fitch plates are secured to their individual brackets of the bonnet surround by three hexagonal-headed setpins which screw into caged nuts fixed to the fitch plate. Four nuts and bolts and one more setpin hold each fitch plate to the leading edges of the scuttle. The heads of these bolts and setpin are accessible from beneath the wings.

A set of four nuts and bolts secure each fitch plate to the radiator mounting frame extension brackets.

### Bumpers:

**Front:** The bumper supporting arms are fixed in the chassis dumb irons by setpins; two setpins pass through each arm into the dumb iron.

**Rear:** A rear bumper is best dismantled by releasing the nut and bolt and setpin that secures each bumper arm to its chassis side member. The bumper can be removed once the electrical leads of the number plate illumination lamp have been disconnected.

### Apron

To support the apron there is a bracket extended from each chassis side member. Two setpins hold the apron to each bracket. At each end of the apron a nut and bolt fixes the apron to each fitch plate.

### Rear Wings

Each rear wing is secured to the bodywork in eleven places. Four of these are hidden beneath each rear door.

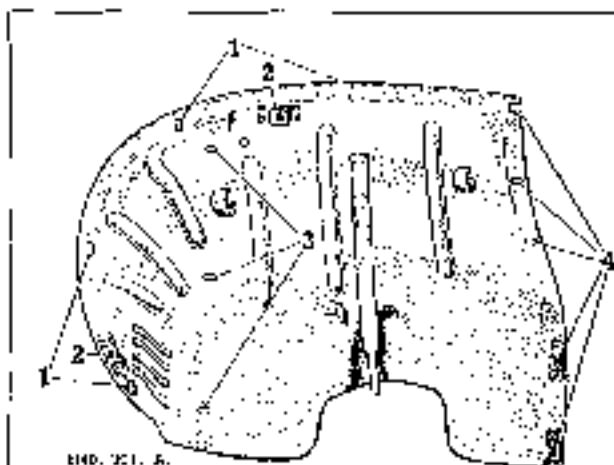

Fig. 2. The fitch plate.

1. Wing fixing points.
2. Dumb iron securing points.
3. Radiator frame fixing positions.
4. Scuttle securing points.



rubber cushion. By peeling back this rubber, four screw type headed bolts are revealed. Withdraw these from their nuts accessible beneath the wing. The remaining seven securing points are nuts and bolts passing through the wheel arch, six of which are accessible within the luggage compartment. To gain access to the seventh, remove the quarter casing situated above the wheel arch and partially obscured by the rear seat squab. The operation is made easier by the removal of the seat squab.

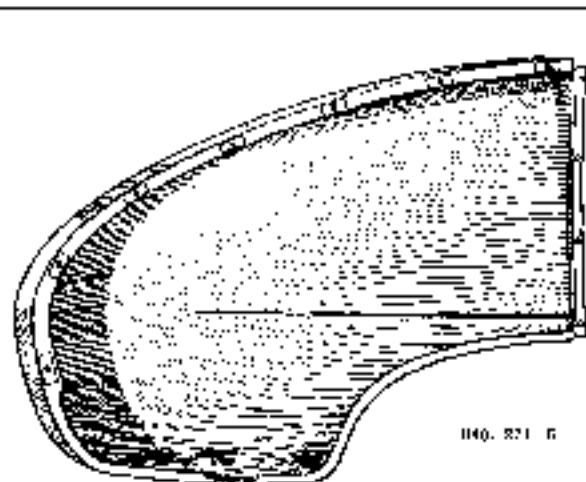

Fig. 3. A rear wing showing securing points.

#### Fascia and Instrument Board

The main fascia is a fixture to the scuttle. The only detachable portions are the central cover panel and the two glove box lids.

To remove the instrument cover panel and so gain access to the instrument board itself there are four

securing screws which have to be withdrawn. Two of these screws are positioned on the underside of the panel. The remaining two screws are reached by opening each glove box lid when the screws will be visible in the upper corner of each box. The two inner control knobs are secured by spring loaded buttons and the two outer control knobs by locknuts.

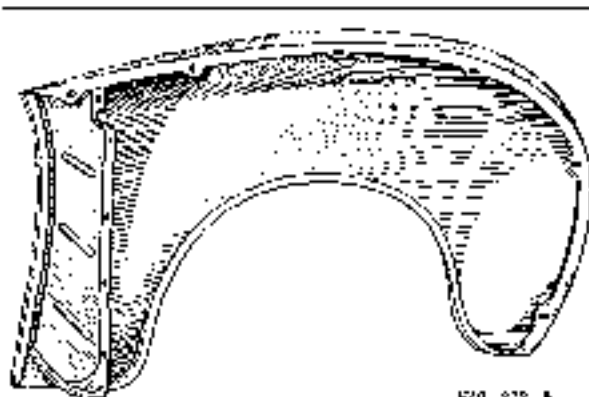

Fig. 5. The front wing and bulkhead plate.

Each glove box is held to the main fascia frame by two screws on the underside of the panel.

With the instrument cover removed, the instruments are free for attention. However, should it become necessary to remove the instrument board, there are six screws to be extracted. One at each corner of the board and two more on the underside.

Where the radio is fitted the control head is fixed in the lid of one of the glove boxes, the side depending on whether the car is of right- or left-hand steering. (See page P/11.)

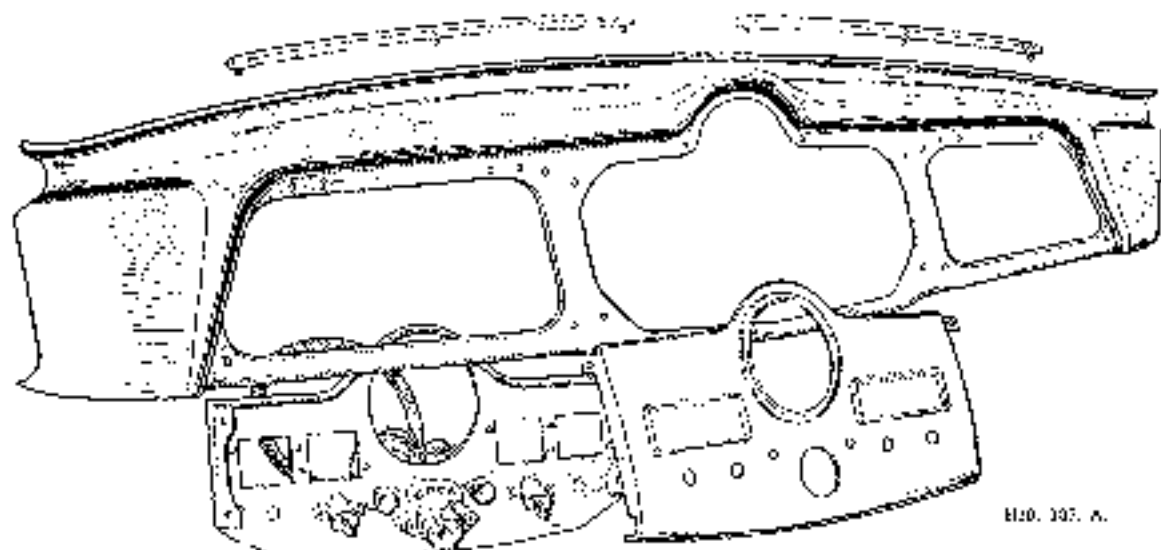

Fig. 4. The main fascia panel is a fixture to the scuttle. Note the instrument board is secured at the rear of the frame and the cover panel at the front.

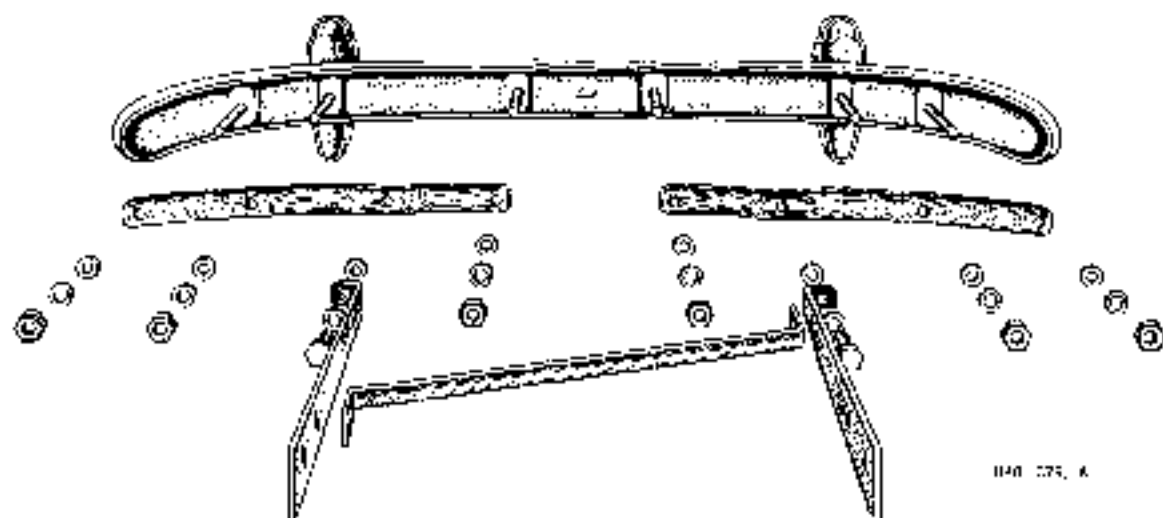

Fig. 6. The front bumper with stay arms exploded.

1140 375, A

#### Valance Panel

Situated beneath the fascia and dash there is a tray called the valance panel. It becomes necessary to partially withdraw this valance when, for some reason, the heater demister pipes have to be disconnected. Under such circumstances the four screws holding the top edge of the valance to the underside of the glove boxes and the five fixing points securing the bottom edge, two of which hold the handbrake bracket, must be removed. The valance can then be removed to the rear an amount sufficient to give access to the demister pipes.

#### Windscreen

In the Somerset car the curved windscreen is fitted into place by a large rubber surround, grooved to take the glass and grooved to fit the frame. The broken parts

of the glass should be removed to enable the rubber jointing to be withdrawn from the metal framing.

Fit the square groove of the rubber jointing round the new glass and run two pieces of flax or strong cord round each free groove in the rubber. Offer the windscreen into position from the outside of the car. Whilst pressing evenly round the perimeter of the screen, the cord or flax on the inside of the car should be peeled out, thus securing the windscreen from the interior. Having completed this, cord or flax on the exterior of the car must be peeled out.

Finally, Bostik solution should be smeared between the metal frame and the jointing, on the outside of the car, and between the outside of the window glass and the jointing. Naturally, two operators should be employed when fitting a new windscreen because of its size.

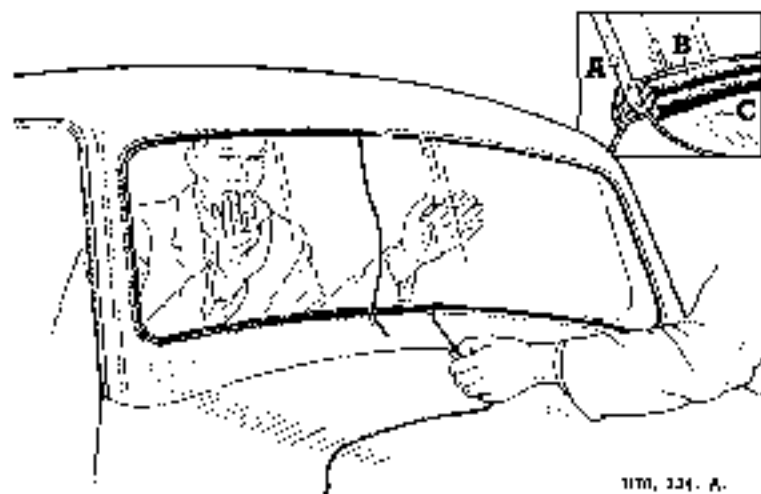

Fig. 7. Securing a windscreen in place. Inset shows section of scuttle, screen and rubber jointing.

- A. Windscreen glass
- B. Rubble, jointing
- C. Scuttle.

1170, 324, A.

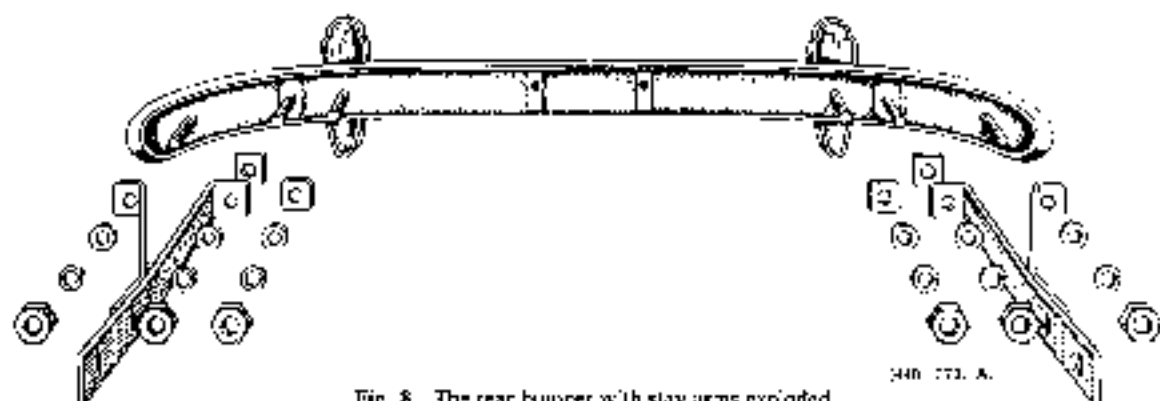

Fig. 8. The rear bumper with stay arms exploded.

### Windows and Doors

**Front Door Windows:** Before it is possible to renew a window, should the necessity arise, the window winding mechanism must be exposed. To do this the window frame moulding securing screws and cup washers must be extracted when the moulding can be taken from the door. In addition to this the door inner casing must be dismantled. Around the perimeter of the leather casing there are twelve screws and cup washers which have to be extracted. The door closing handle is easily separated from the door by simply withdrawing the two setpins accessible from the underside of the handle. Both the window winding handle and the door lock handle must be removed (see section "Door Locks and Handles"). The casing will now come away from the door quite readily.

The window winding handle should be loosely refitted at this stage and the window lowered within its guide channels. This gives access to the securing screws at the rear of the two channels. With these screws removed and the lower half screw, at the base of the channel, slackened, the channel can be manoeuvred from the door.

When in the lowered position it is possible to tilt the window, front edge downwards, so that the runner fitted to its lower edge can be freed from the roller of the single winder arm. Lift the window glass through the top opening in the door.

On replacing the window, grease the runner and reverse the procedure described.

The winder, should it become necessary to remove it, is secured to the door by four setscrews.

**Front Louvre:** The ventilating window, or louvre as it is more often termed, is secured to the door by four brackets and screws. But before the louvre can be removed, the door casing and the window moulding must be dismantled. Both these operations have already been detailed.

When the casing and moulding have been relieved from the door, the main window should be lowered. Then the screws passing through the foremost guide channel must be withdrawn and the channel half screw

slackened. It is then possible to release the louvre by withdrawing the four main securing screws and to lift the louvre from the door.

**Rear Door Window:** Much of the information given for changing a front door window is applicable to the changing of a rear door window.

The casing for the rear door has eleven screws and cup washers to secure it in position and the window moulding five screws. The window itself is removed and refitted in the same manner as a front door window.

**Rear Louvre:** Again the rear louvre is removed in a like manner as described for the front louvre, with the exception that it has five securing points.

**Rear Window:** To renew the rear window, release the screws holding the interior fabric casing. By following the description given for windscreen replacement the operator should experience no difficulty in fitting a new rear window glass.

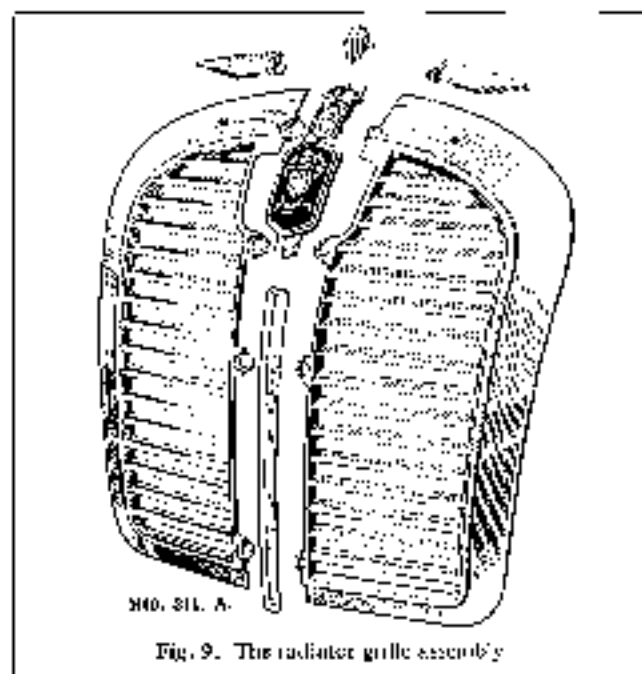

Fig. 9. The radiator grille assembly

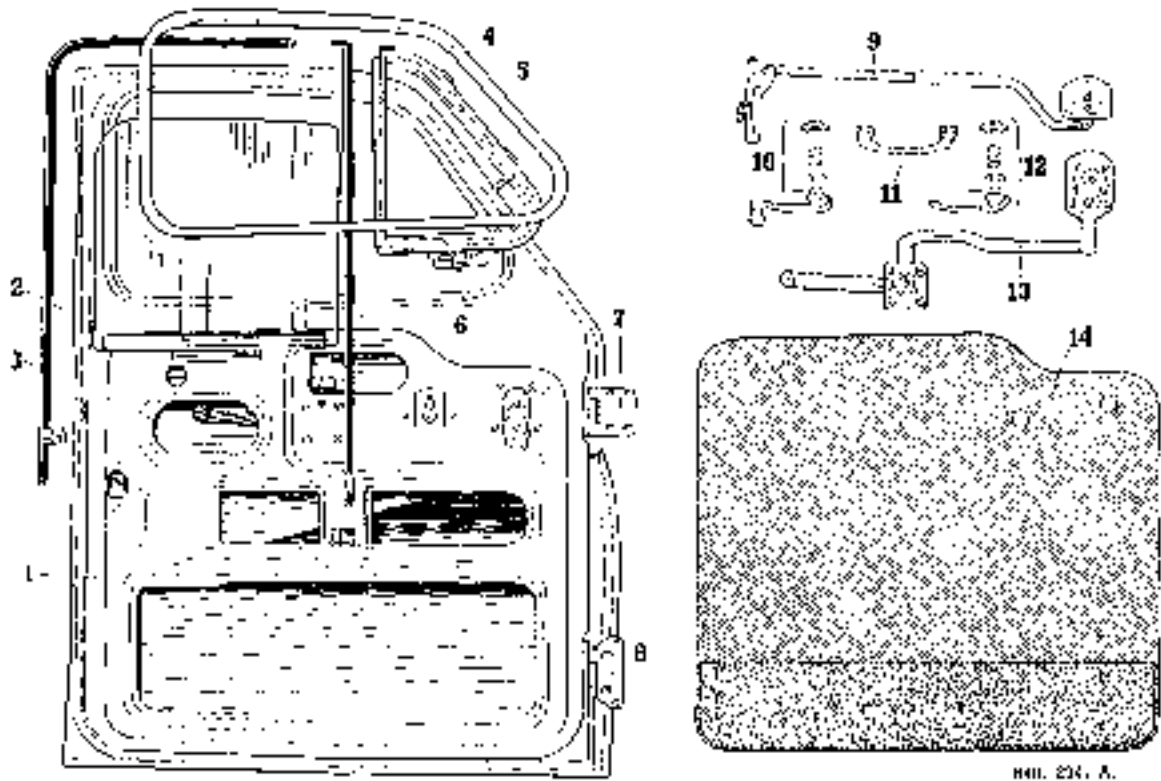

FIG. 10. The near-side front door exploded.

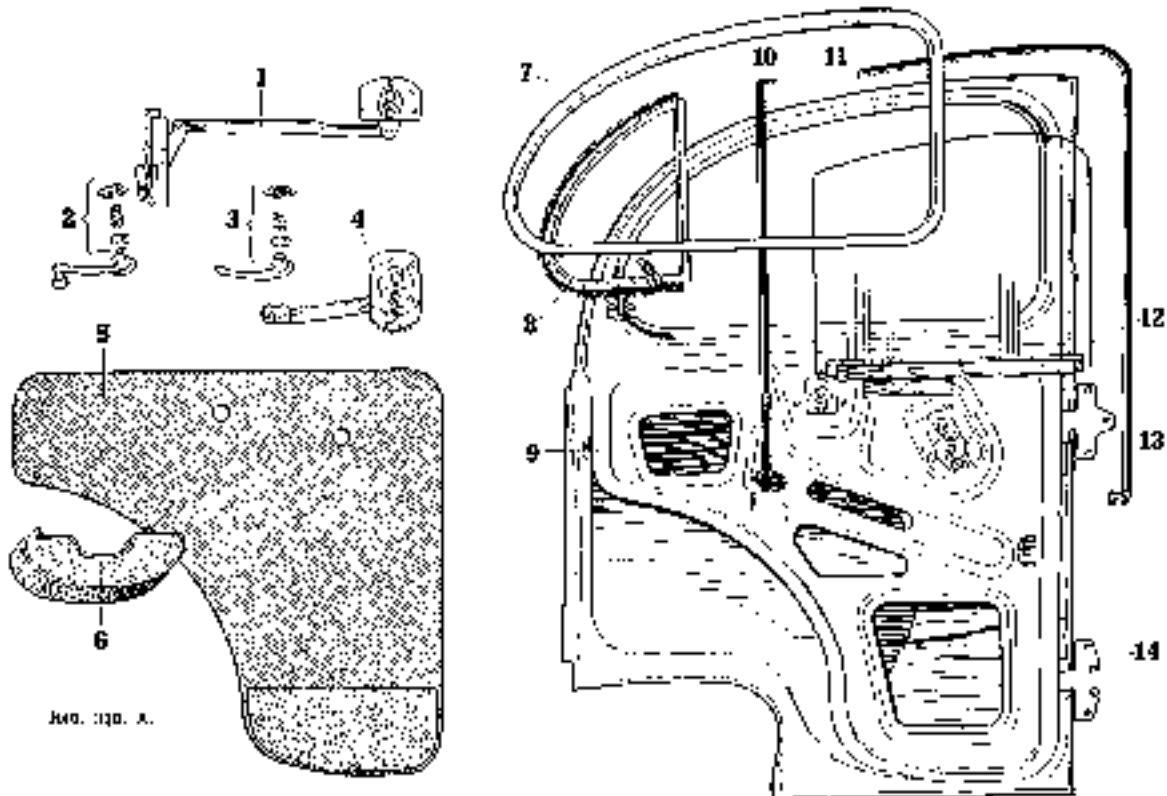

FIG. 11. The near side rear door exploded.

1. Door shell.
2. Window glass.
3. Window rear channel.
4. Window moulding.
5. Louvre assembly.

Caption for Fig. 10.

6. Window front channel.
7. Upper hinge.
8. Lower hinge.
9. Door lock exploded.
10. Window winding handle.

11. Door closing handle.
12. Door opening handle.
13. Window winding mechanism.
14. Door panel casing.

1. Door lock mechanism.
2. Window winding handle.
3. Door opening handle.
4. Window winding mechanism.
5. Door inner casing.

Caption for Fig. 11.

6. Arm rest (door closing handle).
7. Window moulding.
8. Louvre assembly.
9. Door shell.
10. Window rear channel.

11. Window front channel.
12. Window glass.
13. Upper hinge.
14. Lower hinge.

**Hinges and Door Removal:** The upper hinge of the front door has four recessed-headed screws to fix it to the door and four more to secure it to the pillar.

The lower hinge is fastened in the same manner with the exception that it has only three screws holding it to the door.

For the rear doors the position is reversed. It is the lower hinge that has the four screws whilst the upper one has only three.

There is a check strap fitted to each door, front and rear, which must be released when dismantling a door from the bodywork. This operation entails the removal of the door inner casing, an item which has already been described, and extracting the pin that retains the check strap within the door frame.

**Door Locks and Handles:** To remove an interior door handle is quite a simple process. The chrome cup washer is pushed against the concealed spring in which position it is held whilst the peg which passes through the handle and the lock stem is withdrawn. The complete handle assembly can now be removed from the door. This method of handle securing also applies to the window winding handle.

Before a lock or outer door handle can be de-positioned, the inner handles and door casing should be dismantled, a full description of this operation is given under the heading "Windows and Doors".



Fig. 12. A door handle and its two securing screws.

The lock, whether fitted to front or rear door, is secured by four round head screws, visible on the opening edge of the door. By extracting these screws it is possible to lift out the lock mechanism through the door panel. Similarly, the remote control mechanism, after the long connecting link has been released, can be taken out of the door. The latter is secured by three screws in the front door and three in the rear door.

The door outer handle is attached to the panel by two 2 B.A. screws only, one of which is visible on the door's opening edge, the other accessible from within the door panel.

On the occasions when it becomes necessary to remove the door inner casing, the opportunity should be taken to oil the window winding and the door locking mechanisms, through the holes provided in the door shell, see Fig. 10.

An extra locking device is fitted to the rear door interior handles, locking the doors from the inside only. To lock the left-hand and right-hand doors, turn their escutcheons in a clockwise and anti-clockwise direction respectively. It should be noted that this device will not function if the door handle is already in the locked position.

### Seating

**Front:** The front seats can be adjusted for position by pressing the adjustment lever inwards and sliding the seat to the required place. Each seat runner is fixed to the body floor by four screws and can be easily removed should the necessity arise.

**Rear:** The rear seat is of the "drop-in" type, located in position by two pegs, one at each foremost corner which fit in the holes provided in the seat platform.

The rear squab is held by a screw into each wheel-arch and by two at the top edge of the squab, accessible within the boot. The squab should then be lifted straight up to free the two top metal tongues.

### Waist Moulding

The chrome waist mouldings are clipped to the body by special spring clips. Removal of these mouldings

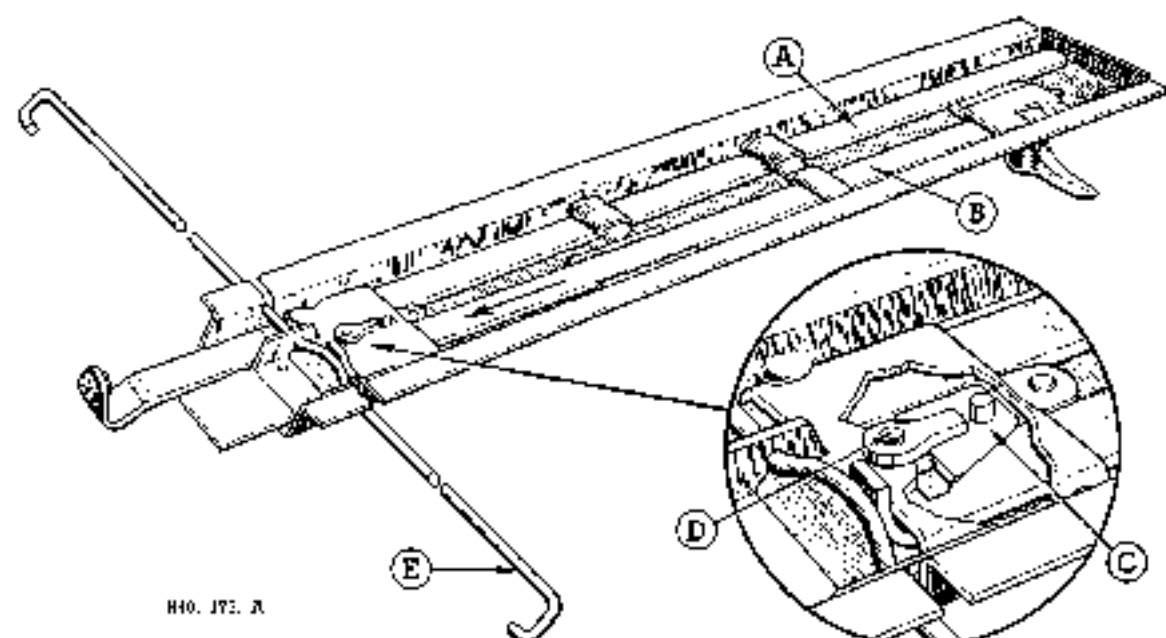

HO. 175. A

Fig. 13. The sliding roof locking mechanism.

A. Slide bar. B. Locking bar. C. Keep-plate. D. Adjusting screw. E. Cranked lifting rod.

involves the simple process of levering the chrome strip away from the bodywork. However, care should be taken to ensure that no harm comes to the paintwork.

All chrome strip is secured in this manner with the exception of the rear wing protection plates. These are secured through the wing by three setscrews.

### Sliding Roof

**Description:** The roof fitted is the patented Pychely design which should require very little attention from the mechanical standpoint. However, it is important that the water troughs are kept free of obstruction and the runners free from rust.

**Removing the Sliding Roof:** To remove the sliding roof, first unlock it and then take away the side draught strips from the roof opening. Release the two screws holding the two brackets at the forward side edges of the panel and push these brackets outward and clear of the edges. This sliding portion of the roof may now be lifted at its front end and pulled clear of the car. During this operation it is advisable to cover the front canopy with felt, or similar material, as a protection for the paintwork.

Two operators should be employed when replacing the roof; the person inside the car guides the slide bar (A) Fig. 13, into its housing within the channel as the one on the outside replaces the roof.

If the slide bar does not enter the housing correctly it will override the channel and consequently tear the fabric lining, or "ruck-up" the protective felt glued to the underside of the locking channel.

**Locking Device:** The locking mechanism is engaged with a channel running centrally from front to rear of the sliding roof panel. This channel is spot-welded into position and the whole enclosed by a fabric covered board. The latter is clinched to a frame mounted within the sliding roof panel.

The locking handle is secured through its head by a female screw to the lock spindle, whilst beneath the handle is fitted a double spring washer.

Should adjustment to the locking mechanism be necessary, first release the fabric board at the rear edge of the sliding roof, which will give access to the adjusting screw situated towards the rear of the locking channel. The adjustment is made by slackening this screw, pushing the screw head as far forward as possible and then retightening. Test the roof mechanism to ensure that it will lock the roof panel in any desired position before replacing the lining.

The workings of the mechanism are simple but effective. By turning the handle, an eccentric peg is moved through 90 degrees, thus pushing the bar (B) Fig. 13, to the rear with a slight movement to the left.

This bar incorporates a taper at its rear end which slides against an opposing taper of a small keep-plate (C) and forces the latter over to the left to butt-up hard against the slide bar (A) thus securing the sliding panel in any desired position. On adjustment, the adjusting screw keeps the tapers of the keep-plate and locking bar hard up in one another when in the locked position.

The rearward movement of the locking-bar rotates the cranked rod (E), which passes through the channel and across the sliding roof panel. The hooked ends of the rod lift on the brackets in the water trough at each end of the roof opening, when the roof is unlocked. This turning and lifting movement of the hooked ends keeps the panel flush with the main roof.

The slide bar is secured to a bracket mounted in the main roof and remains in position when the sliding panel is removed.

#### Roof Drains:

The drainage of the sliding roof is accomplished by rubber tubing secured to drain pipes at each corner of the water trough. The forward tubes may be traced down each foremost door pillar, behind the easing, and through the body floor. The rear tubes follow the rear pillar of the rear door and make their exit through the wheel arch.

Should a water leak appear within the car, it may be attributed to one of the two following causes and effectively dealt with.

- (a) A blocked drain pipe.
- (b) A faulty weld at one of the four mitred corners of the water trough.

#### "A40" Coupé Hood

The hood can either fold back to give the De Ville position, or it can be lowered completely. To gain the De Ville position, a knob on each side cantrail is released and the cantrails bent inwards. The front rail is pushed back halfway and secured by two straps which loop over the folded portion of the hood and are press-studded to the centre rail of the hood. Further lowering of the hood is achieved by releasing at each side, in the rear compartment, the two locking handles and then pulling the hood rearwards and so into the well behind the rear seat squab.

Before raising the hood it is essential to lower the rear quarter windows. Grasp the hood pillars firmly, raise the hood, stam the pillars into the vertical "De Ville" position; and, *this is most important*, ascertain that they are both securely locked. When the front of the hood has been unstrapped, the pegs on the front rail must enter the holes provided in the windscreen frame before the cantrails are straightened and locked.

N.B.—Keep the fingers clear of the knee action joints when straightening the cantrails.

The hood is best cleaned with the aid of soap and water and a soft brush. However, if it has been allowed to become very dirty, a small amount of Benzine may be used. The interior of the hood should be cleaned with Trico-ethylene sparingly used.

#### Heater

**Description:** The air distribution of the heater is regulated by fascia controls which enable the car heating and screen demisting to be used together or independently, while in warm weather these same controls can turn off the heat so enable the system to be used as a fresh air ventilator.

Fresh air is drawn from outside the car, heated by hot water from the engine cooling system and then distributed inside the car.

The fascia controls are in quadrant form and their correct use ensures complete comfort for the driver and passengers. The danger of poor visibility caused by frost on the windscreen can also be overcome. To meet extreme conditions an electric fan is fitted to the system which considerably increases the amount of air fed into the heater. The fan can be used when the car is stationary to compensate for the lack of the ram effect into the air intake caused by the car's forward motion. When in dense traffic, the air supply to the car interior can be shut off if desired thus preventing the entry of exhaust fumes, etc.

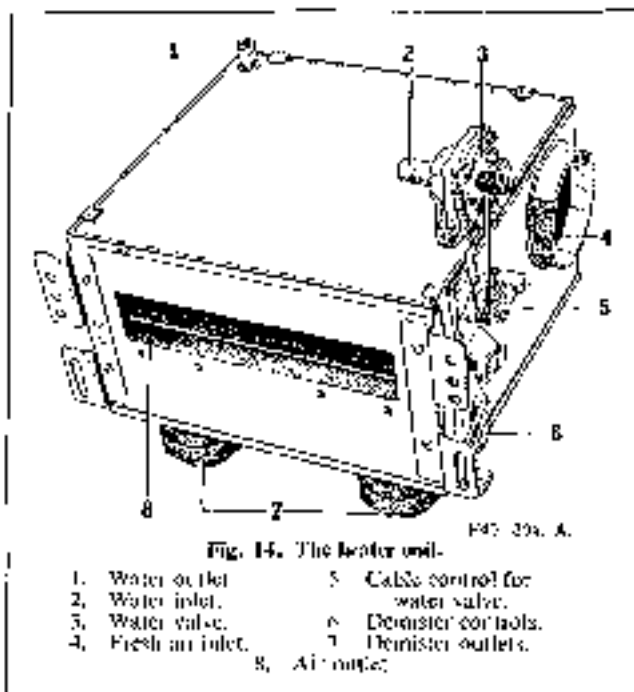

**Controls:** A quadrant control having two levers—a demisting/def-rosting control lever and a heating/ventilating control lever—is fitted beneath the fascia. The former is attached by a flexible cable to the demister/defroster valve of the unit; the latter to the exterior air valve and to the water valve. There is an on/off switch for the fan motor.

An "extra air" control knob is situated on the left of the quadrant. This control is in no way connected to the heater; when operated it merely allows extra fresh air into the car interior, the force of the air being dependent

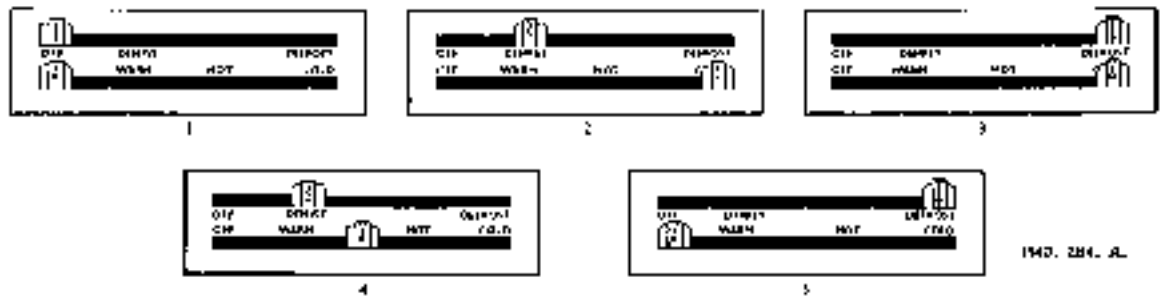

Fig. 15. Operation of heater controls.

1940, 284, A.

Conditions to be met

- 1. No ventilating and no screen air supply.
- 2. Warm Weather—cold ventilating air supply, cold supply to screen.
- 3. Warm Weather—some ventilating air, maximum cold supply at head level.
- 4. Cold Weather—hot ventilating air supply, warm air to screen.
- 5. Freezing Cold days—some hot ventilating air, maximum hot supply to screen.

Heating/Ventilating lever position

- "OFF"
- "Cold"
- "Cold"
- Between "Warm" and "Hot" according to heat required.
- "OFF"

Demisting/Defrosting lever position

- "OFF"
- "Defrost"
- "Defrost"
- "Defrost"
- "Defrost"

on the car's forward motion and the amount of valve opening. For the operation of the controls, see Fig. 15.

Adjustment of Heating/Ventilating Control

(a) Move the ventilating control lever on the fascia panel to the "off" position—the air valve lever on the heater unit should now be at its extreme forward position and negligible air should enter the car with the fan motor running (i.e. only reasonable valve leakage).

(b) Move the ventilating control lever to the "hot" position—the lever on the heater unit should now be at its extreme rearward position with the water valve about to commence closing (i.e. with only slight movement of the water valve lever towards the closed position).

(c) If the correct operation in (a) or (b) is not being obtained, the length of the inner member of the control cable must be adjusted. This may be done at the control end or the heater end, whichever is more convenient. Slacken the clamping screw on the cable transition, slide the cable through by an appropriate amount and re-tighten the screw. Re-check as in (a) and (b) above.

(d) Move the ventilating control lever in the "cold" position—the lever on the water valve should now be in the vertical position with the water flow in the heater cut off. After 2-3 minutes (with fan motor and engine running) air entering the car should be cold. If this is not so, it indicates that water is still flowing through the heater core. This may be checked by removing the top (return)

water connector hose and observing whether water is issuing from the heater core when the engine is running at normal speed, the open end of the hose being closed manually during running.

(e) If the water flow is not entirely cut off as in (d) proceed as follows: With the ventilating control lever still in the "cold" position, slacken the clamping screw holding the water valve operating rod (beneath cable attachment). Move the water valve independently of the heater valve—a slight resistance to motion should be felt as the lever approaches and passes the vertical position—indicating that the valve is seating correctly. If this resistance is not felt an adjustment should be made to the centre screw on the water valve lever—one quarter of a turn clockwise is usually sufficient. With the ventilating lever still in the "cold" position as in (d), refit the water valve operating rod and, holding the water valve lever in the vertical position, re-tighten the clamping screw.

Adjustment of Demisting/Defrosting Control

(a) Move the demisting control lever on the fascia panel to the "off" position—the demist valve lever on the heater unit should now be at its extreme forward position and no air should pass through the windscreen nozzles with the fan motor running.

(b) Move the demisting control lever to the "defrost" position—the lever on the heater unit should now be at its extreme rearward position.



(c) If the correct operation in (a) or (b) is not being obtained, adjustments must be made as for (c) in "Heating/Ventilating Control Adjustment".

### Heater Removal

Before withdrawing the four setpins which hold the heater to the scuttle, there are other items of heater equipment that have to be disconnected.

The Bowden cables operating the air valve and demister valves should be disconnected at the heater unit. Then the demister pipes should be disconnected from the unit by releasing their clips at the heater end. There a little difficulty may be experienced due to the fact that to gain access to these clips the valances beneath the fascia must be removed. The two hot water pipes are each secured to the heater connections by clips. These must be released and in the same manner the main air pipe must be dismantled from the heater box.

The fan motor does not normally require servicing as the bearings are packed with lubricant on assembly. To remove the fan from its mounting, however, merely entails first releasing the hose clips and pulling the hose free of the fan outlet. Then disconnect the single electrical lead at its local snap joint connection and finally remove the three nuts and washers from the fan body securing studs. The motor and fan as a combined unit can now be removed from its mounting.

Replacing the heater unit, or fan and motor, is

achieved by simply reversing the given removal instructions.

### Radio

For tuning and setting up of the push buttons, the operator should refer to the small booklet issued with each radio set when supplied by the manufacturers.

**Removing the Radio:** Should it become necessary to remove the radio set for any reason, the four bolts securing the carrier bracket to the scuttle bulkhead must be withdrawn. The set complete with bracket can then be retrieved from beneath the dash panel inside the car. When releasing the cables from the set be sure to identify them with their relative sockets for ease of replacement.

**Removing the Control Head:** The control head is situated in the glove box compartment on the driver's side. To remove the control head the compartment lid must be opened and the flexible control wires and cables disconnected. By removing the four retaining screws, two each side, the face plate complete with control head and "U" bracket may be lifted out of the compartment.

**Loudspeaker:** The speaker is hidden from view behind the fabric lining of the canopy immediately above the windscreen. With the lining released and peeled back it becomes possible to extract the screws that retain the speaker in place, when the cables should be disconnected at its rear.

## BODY REMOVAL

**I**N the rare event of complete body removal being necessary, the operator should read the preceding itemised part removals as there are fifteen preliminary operations to be effected before it is possible to release the body securing bolts and thereby separate the coachwork from the chassis. These fifteen operations are outlined in the following paragraphs:

1. Disconnect the battery leads and remove the battery complete.
2. Dismantle both front and rear bumpers from the chassis complete with arms.
3. Disconnect the electric cables at the dynamo, starter and coil.
4. Break the snap connections, near the radiator frame, of the direction indicators and horn cables.
5. Drain the cooling system, extract the thermometer bulb from its tank position, then release the radiator from its mounting, after releasing the brake supply tank, and if it cannot be adequately supported release the hoses and remove the radiator complete.
6. Remove the set bolts that secure the radiator frame to the chassis front cross member.
7. Release the speedometer cable at its gearbox union.
8. Disconnect the throttle and choke controls at their carburettor connectors, also the heater pipes from the heater box.
9. Separate the oil gauge flex pipe from the scuttle copper pipe.
10. Disconnect the handbrake control at the base of the control rod.
11. Disconnect the steering box from the chassis.
12. Remove the gear lever operating arm, fix the change control rod from the chassis, also disconnect it at the mechanism and then extract the rod from the bodywork.
13. Remove the pads from the brake and clutch operation pedals and then remove their floor board pads.
14. Release the fuel delivery pipe from its tank union having first drained the tank.

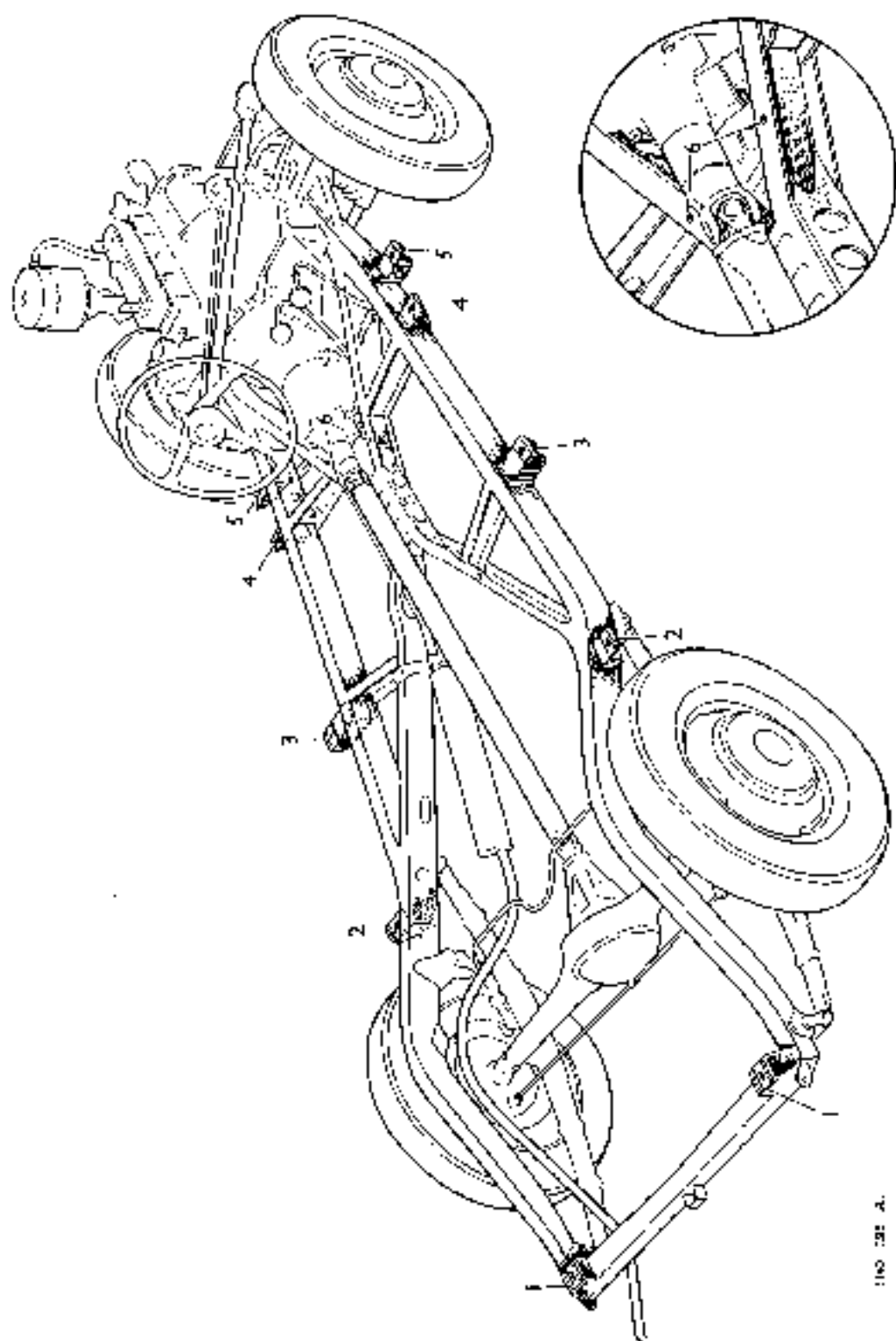

FIG. 16 A.

Fig. 16. Illustrating the main body mounting points on the chassis, numbered from 1 to 6. Inset shows points No. 4 on right

15. Under the inner carpet at each side of the body are three small panels and one each side of the gearbox cover. With these panels removed, access is gained to the heads of the body holding down bolts.

At each side of the body there are five sets of nuts, bolts and washers and rubber pads for securing the body, through brackets, to the chassis. Further, through the chassis cross bracing members each side of the gearbox

there is one more nut, bolt, washer and rubber pad.

The body may now be removed from the chassis as one complete unit, using a suitable sling which should lift the rear of the body first. Lifting operations should be slow and the body carefully pulled rearwards to clear the remaining controls.

Replacing the body is an exact reversal of the removal instructions.

## DISMANTLING AND ASSEMBLING BODY PARTS

### COMMERCIALS

In most instances the body parts of the Van, Countryman and Pick-Up are identical and only where differences occur will they be mentioned individually.

#### Roof Top

Described in Section D, page 18.

#### Front Wing Assembly Complete

The front wing assembly comprising both front wings, fitch plates, head and side lamps, radiator grille and front apron can be removed as a complete unit.

First remove the two baffle plates located under each front wing at the rear. These plates are secured by four screws to the scuttle and by two screws to the wing.

On each side, remove the two screws which hold the rear of the outer wing half to the scuttle. Then remove the one bolt on each side of the car which holds the rear of the engine fitch plate to the scuttle. These bolts are fitted with plain and spring washers.

Disconnect the headlamp cables at their nearest convenient snap-on connectors and then remove the four bolts securing the fitch plates on each side of the radiator stay bar. The three lower bolts are inserted from inside the wing and its front support bracket. They have a large plain washer under the bolt head with a plain and spring washer under the nut. The top securing bolt, inserted from the radiator stay bar bracket through the fitch plate, has a plain and spring washer under the nut.

The complete assembly can now be lifted clear. Replacement is an exact reversal of the removal instructions.

#### Front Wings and Fitch Plate

The two halves of a front wing can either be removed as one unit or if required the outer half only need be removed.

To remove the outer half, first take off the lamp front cover and unscrew the two outer securing pins which hold the lamp body to the wing. These securing pins are held by brass nuts under the wing and the nuts

have solid rear faces to prevent corrosion of the securing pins. Remove side lamp which is held by three brass nuts.

Then release the two bolts holding the outer half of the front wing to the baffle plate at the rear underside of the wing and release the two bolts which hold the rear upper flange of the outside wing to the scuttle.

The outer half of the wing can now be removed when the twelve bolts, which hold the wing to the front apron and inner wing, have each been removed.

Replacement is a reversal of the above, but make sure that the beading is properly fitted between the wing halves and that each of the securing bolts are fitted with plain and spring washers.

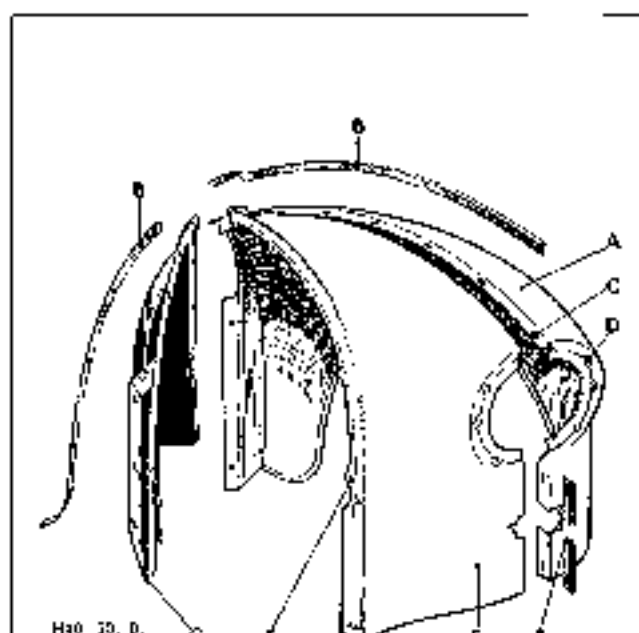

Fig. 17. Front wing and fitch plate.

A. Outer wing. B. Beading. C. Inner to outer wing bolt hole. D. Headlamp mounting point. E. Inner wing. F. Inner wing to fitch plate bolt hole. G. Fitch plate.

If the inner wing is to be removed, both the inner and outer wings should be removed as a complete unit by detaching the five front apron to wing bolts, the six bolts securing the inner wing to the fitch plate and the rear baffle plate bolts and outer wing bolts to the scuttle mentioned previously. The wing assembly can be removed complete when the head and side lamp cut-offs have been disconnected at their snap-on connectors. The two wing halves are held together by ten bolts and by four headlamp bolts, and three side lamp nuts.

To remove the fitch plate it is necessary to unscrew the two bolts at the rear and the four bolts at the front which secure the plate to the scuttle and radiator stay bracket respectively. Three of the front bolts will also release the support bracket which is positioned under the front of the wing assembly.

Assembling is again a reversal of dismantling.

#### Bumpers and Apron

Both front and rear bumpers can be quickly removed and replaced as each is held in position by easily accessible securing bolts and nuts. When replacing always ensure that the nuts have spring washers and are tightened firmly.

The front apron is held to the front wings by twelve bolts, five on each side and two in the centre. Two of these bolts on each side help secure the wing front support brackets. Again when assembling, ensure that the plain and spring washers are fitted to each bolt and position the beading correctly.

#### Lower Grille and Bumper Catch Plate

The lower grille is held at each side by one nut, bolt and washer and two set-pins. Three nuts, bolts and washers secure it to the front apron. Before the grille can be removed a further two nuts and bolts, situated behind the grille, holding the catch plate stay to the apron must be released. Also disconnect the bumper control cable and the electrical wiring from the catch plate.

#### Rear Wheel Covers

With the exception of the Pick-Up, the latest models have the rear wheel cover incorporated in body side panel pressing. The Pick-Up and early models have separate wheel covers secured by four screw headed bolts of bayonet type fixing.

#### Windscreen

The windscreen is held in position by two securing bolts in each windscreen pillar. Access to these bolts is obtained by removing the side mouldings each held in position by two screws.

Release the four bolts and the windscreen should then be raised from the bottom until its lower securing lug is disengaged. Then pull the bottom of the windscreen outwards and down to disengage the top securing lug. This operation is best achieved by two operators—one inside and one outside the car. When replacing the windscreen engage the top securing lug first, allowing the bottom securing lug to drop into position. Replace the four securing bolts and tighten evenly.

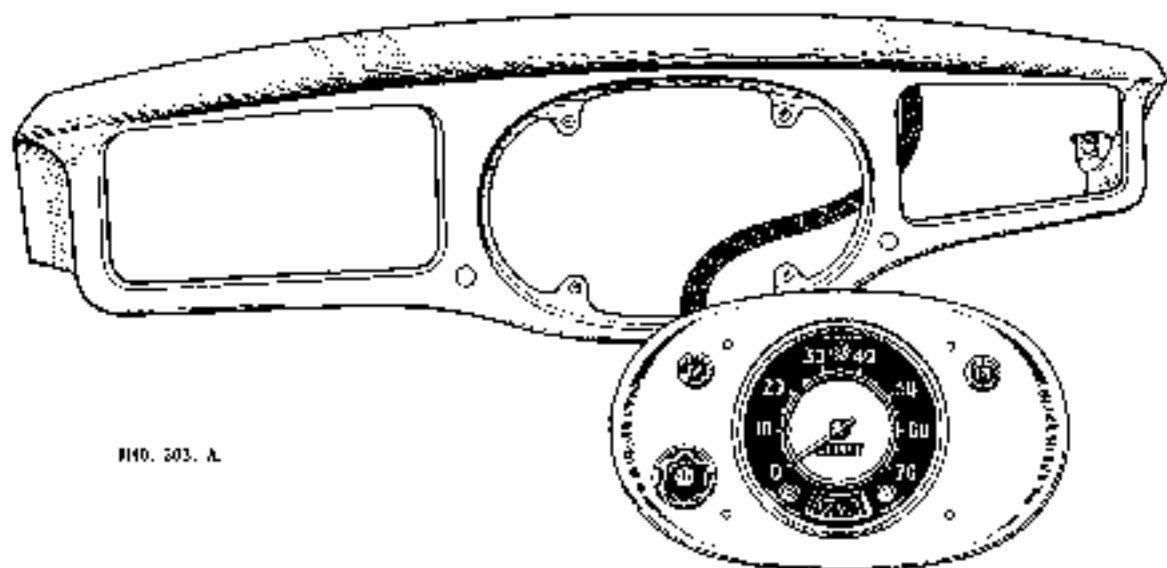

FIG. 18. A.

Fig. 18. Fascia with the instrument panel exploded.

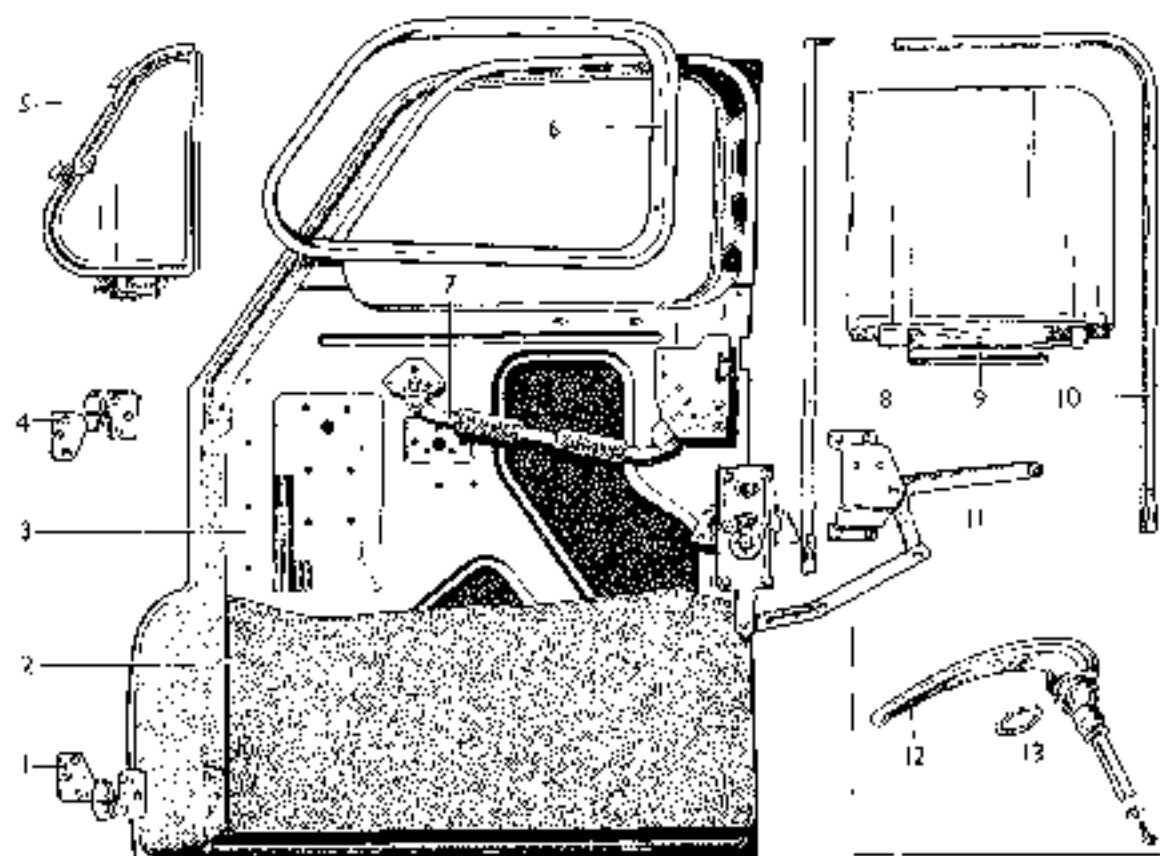

Fig. 19. The off-side front door exploded.

1. Lower hinge.
2. Door inner casing.
3. Door shell.
4. Upper hinge.

5. Lower assembly.
6. Door molding.
7. Door loss mechanism.
8. Window frame channel.
9. Window glass.

10. Window seal channel.
11. Window weathering mechanism.
12. Door outer handle.
13. Rubber molding.

849 397 6.

### Fascia Panel

Before the fascia panel can be removed, the instrument panel, starter and choke control wires must first be released.

The instrument panel is held to the fascia by four setpins visible on the face of the instrument panel. The starter and choke control wires must be released at the starter switch and carburetor respectively.

The fascia panel is secured at each end by one nut and washer and by two nuts, bolts and washers to each glove compartment. The top edge of the fascia panel is clamped between the windscreen and its frame, consequently the four windscreen securing setpins (see windscreen) should be slackened before attempting to remove the fascia panel.

### Valance Panel

This panel, situated immediately beneath the fascia, is held at its lower edge by three setpins and to each

glove box by two nuts, bolts and washers. The glove boxes can be released when the four remaining setpins, securing them to the scuttle, have been removed.

### Heater

To remove the heater, first drain the cooling system and then disconnect the two hose clips on the two pipes protruding forward through the scuttle from the heater unit. Pull off the connections from these two pipes, disconnect the two heater cables and release the two screws holding the demister piping to the rear of the heater. The heater unit can be lifted from the scuttle compartment when the plate on top of the heater unit compartment has been removed by releasing its nine setting screws.

Full access to the demister flexible pipe or pipes can only be obtained if the fascia is removed. The flexible pipe discharge vents are secured to the body by two self-tapping metal screws.

The heater motor bearings are packed with lubricant when the unit is first assembled and servicing should not normally be necessary.

### Doors and Windows

**Door Renewal:** The upper and lower hinges of the front doors are each held in place by three setscrews. With these removed, the door can readily be detached from the bodywork.

**Door Windows:** Before either the window or the louvre can be withdrawn, the door inner casing must be detached. The handles are released in an identical manner to those of the Saloon (see page P/7). The door inner casing is secured by fifteen metal thread screws.

Release the window moulding by extracting five screws. Lower the window and release the screw at the top and slacken the nut and bolt at the bottom of the vertical window channel. This enables the louvre to be extracted once its three securing screws have been removed.

Finally, rotate the window stop downwards by releasing the top two of its three fixing screws, so that the window can be lowered to its fullest extent thus allowing the roller to become free of its guide channel.

When the window has been removed, undo the ten setpins holding the window winding mechanism and withdraw it through the bottom opening in the door panel.

**Door Locks:** To remove the door locking mechanism, the door inner handle must first be released. This handle is held in position by a setscrew and washer accessible on the door inner panel. Simply remove the screw and pull out the handle.

On the right-hand door the barrel type lock, just below the door outer handle, is held by strap springs and must be prised out with the aid of two screwdrivers.

With the door handle and barrel lock removed, the locking mechanism can be detached by releasing its four securing setscrews, two in the door edge and two on the door panel. Three setscrews hold the door interior handle end of the mechanism.

Finally, remove the unit through the opening provided in the door panel.

### Side Windows

**Countryman:** Before these windows can be taken out, the wooden frames surrounding them must be removed; each frame being held by fourteen wood screws.

The forward side window is of the sliding type and is fixed in position by rubber moulding and metal thread screws. Rubber moulding alone holds the rear side window in place. Adopt the same method of fitting as that employed for the rear door windows of this model. See Fig. 20.

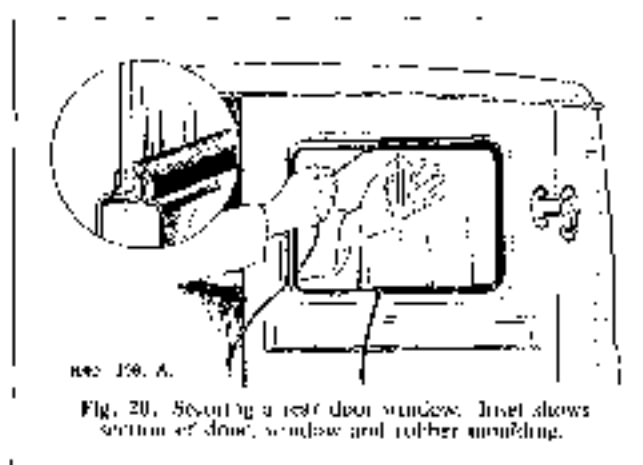

FIG. 20.

Fig. 20. Seating a rear door window. Inset shows section of door, window and rubber moulding.

### Rear Doors and Windows

**Van and Countryman:** The rear doors and windows of these two models are identical, therefore the removal procedure is the same.

Either rear door can be easily tilted clear of the bodywork once its metal check strap and two hinge pins have been removed. To release the check strap, take out the split pin and remove the rubber stop. Each hinge pin is held by a nut and lockwasher and on their removal the pins can be tapped out.

The Countryman and Van rear door windows, also the Pick-Up cab rear window are held in place by rubber moulding, see Fig. 20. Their removal and replacement is effected in the same manner as the Saloon rear window.

### Seating

**Van:** Each front seat is held by four setpins. Adjustment is made by simply slackening these setpins and moving the seat to the required position. Finally retighten the setpins.

**Countryman:** Each front seat is secured to the body floor by two setpins and two nuts and bolts. Their seat squabs hinge forward to allow entry to the rear seat.

The rear seat is held at its front edge by two hinges and can be tilted forward to permit the rear seat squab to hinge down flush with the floor boards, thus giving extra floor space. The two hinges of the rear seat squab are each secured by two setscrews.

**Pick-up:** The metal base of the drop-in bench type seat is secured to the floor by four setpins. The seat squab is held by two screws along its top edge.

### Floor Boards

These are of similar construction for the Van, Countryman and Pick-Up and can be readily removed once the securing screws have been extracted.

## BODY REMOVAL

The preliminary body removal procedure for the Commercial vehicles is similar to that given for the Saloon

(see P:11) with the exception that the exhaust tail pipe must be released from the rear of the body.

The body main securing points are illustrated in Fig. 16, page P:12, and it should be noted that the body mounting point numbered (5) is not used for these

vehicles. Note: On the Pick-Up model the truck body can be separated from the cab, either before or after removal, by taking out the sect squab and extracting the nuts and bolts holding the two parts of the body together.

## DISMANTLING AND ASSEMBLING OF BODY PARTS

### A40 SPORTS

#### Bonnet Top

Remove the bonnet top by undoing the two bolts, with nuts and washers, that secure the bonnet support to the upper half of the heater compartment. From each bonnet hinge remove two nuts each with one flat and one spring washer. The bonnet is now free to be lifted clear of the bodywork.

#### Shroud

The shroud assembly includes the grille, the two front wings and the baffle plates.

The first of the dismantling procedures is to disconnect the lighting cables and horn leads at the nearest soap joint connectors.

There are three setpins passing through the shroud at each side into caged nuts on the top edge of the fitch plate and three more setpins into fitch plate caged nuts on the plate front flange.

Beneath the wings there are three nuts and bolts at each side which hold the shroud to the scuttle panel. A further setpin visible on top of the scuttle, beneath the bonnet opening, secures each side of the shroud to the scuttle.

At the rear of the wheel at each side there are five more securing points, along the underside of the wing flange. Two are setpins, the foremost one is a nut and bolt, and interposed between the hexagon heads are two roundhead self tapping screws.

There is one more setpin into the scuttle bracket behind each door. To gain access to the heads of these setpins each door must be opened.

Finally the bonnet release cable must be disconnected from the bonnet catch.

When each of these securing points have been made free the complete shroud assembly may be lifted and carried forward clear of the car.

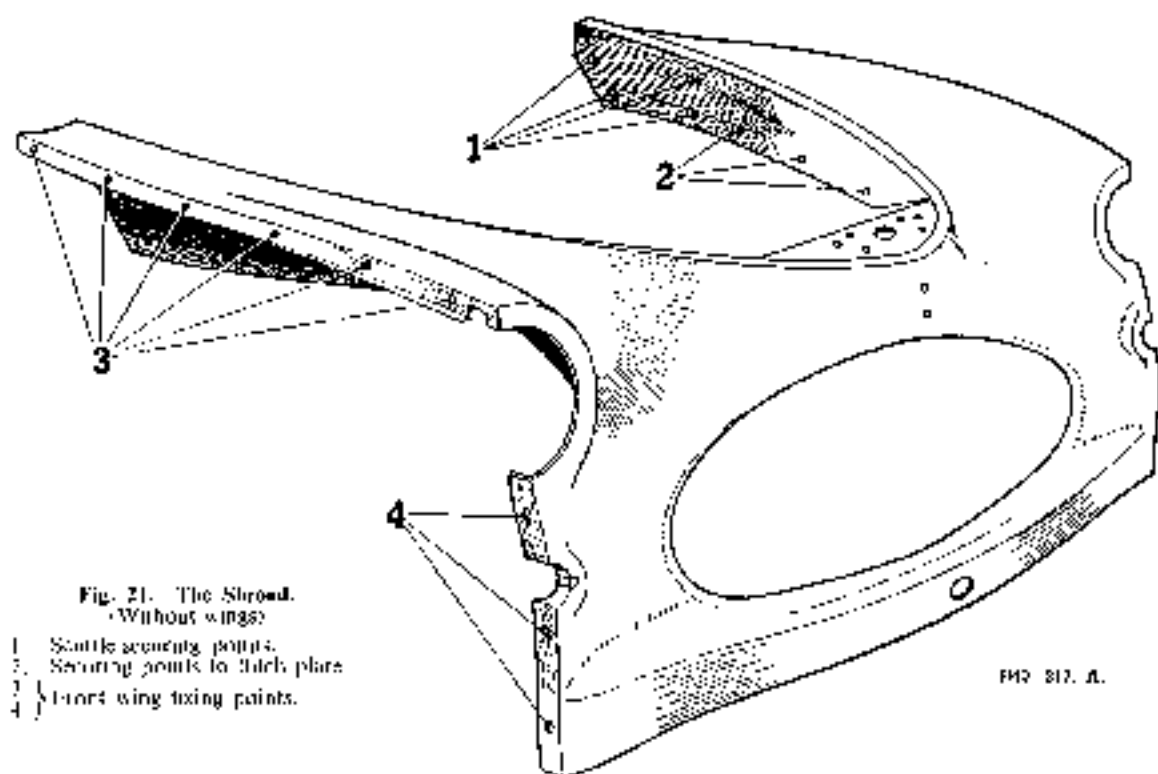

Fig. 21. The Shroud.  
(Without wings)

- 1 Scuttle securing points.
- 2 Securing points to fitch plate.
- 3 } Front wing fixing points.
- 4 }

### Grille

The grille is secured to the shroud at eight points behind the opening. Two cheese head screws, visible on the top face of the bonnet catch plate, screw into tapped holes in each central grille supporting pillar. At the base of the supporting pillars, which are angled through 90°, there are two nuts and bolts holding the grille to the front of the shroud. Access to these nuts and bolts can only be gained by removing the front bumper.

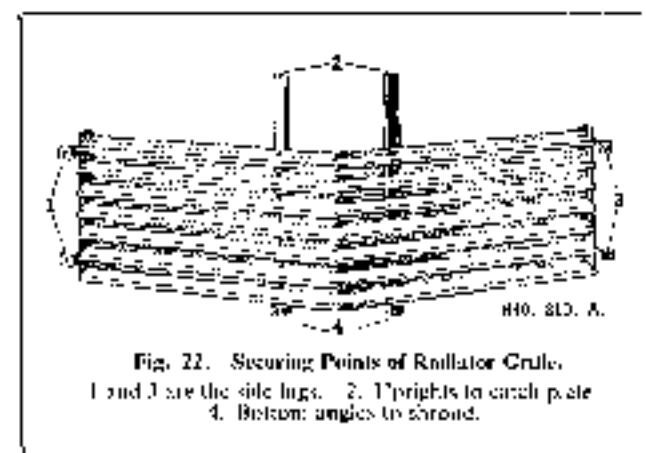

Fig. 22. Securing Points of Rollator Grille.

1 and 3 are the side lugs. 2, Uprights to each plate.  
4. Bottom angles to shroud.

At each side of the grille angled brackets with nuts and bolts, top and bottom, fix the assembly to the shroud.

When the eight securing points are released, and the steering cross tube removed, the grille can be manoeuvred out from beneath the car.

### Front Wings

Before the actual wing dismantling operations can commence the head and side light cables should be disconnected at the snap connectors on the inside of the fitch plates. Then the lamps, complete, must be removed as detailed for the Commercial models.

Taking one wing as an example for the removal sequence, there is one nut and bolt through the front lower corner of the wing, fixing the wing to the shroud.

Next, there are two nuts and bolts holding the wing, shroud and baffle together. Six more nuts and bolts hold the wing to the shroud along the top edge. Then as described for the shroud removal there are the five securing points beneath the rear lower edge of the wing and the setpin into the scuttle bracket, visible when the door is opened.

### Fitch Plate

The securing points holding each fitch plate in position are clearly shown in Fig. 24. The three foremost points are those set in a vertical line where setpins secure the fitch plate to the baffle. Immediately behind these there is a vertical line of three nuts and bolts fixing the plate to the radiator mounting frame.

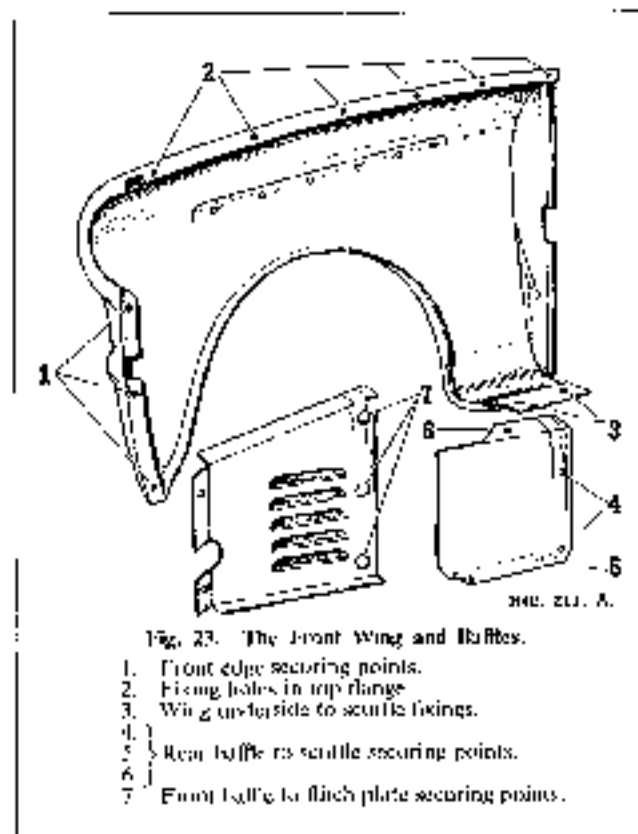

Fig. 23. The Front Wing and Baffles.

1. Front edge securing points.  
2. Fixing holes in top flange.  
3. Wing underside to scuttle fixings.  
4, 5, 6. } Rear baffle to scuttle securing points.  
7. Front baffle to fitch plate securing points.

At the top of the fitch plate three setpins pass into caged nuts followed by a single nut and bolt. In a diagonal line across the fitch plate there are three nuts and bolts. At the rear lower corner of the plate two nuts and bolts secure the plate to the rear baffle whilst above the latter points, and accessible within the car, two nuts and bolts pass through the fitch and scuttle.

### Rear Wings

The preliminary operations before separating a rear wing from the main bodywork are these:—

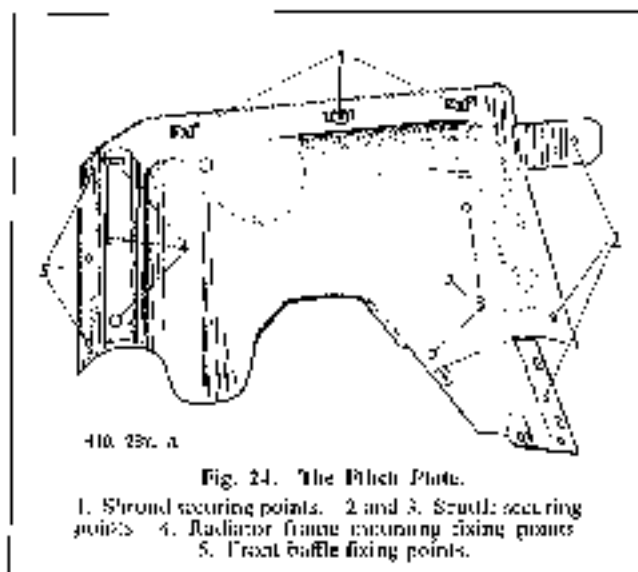
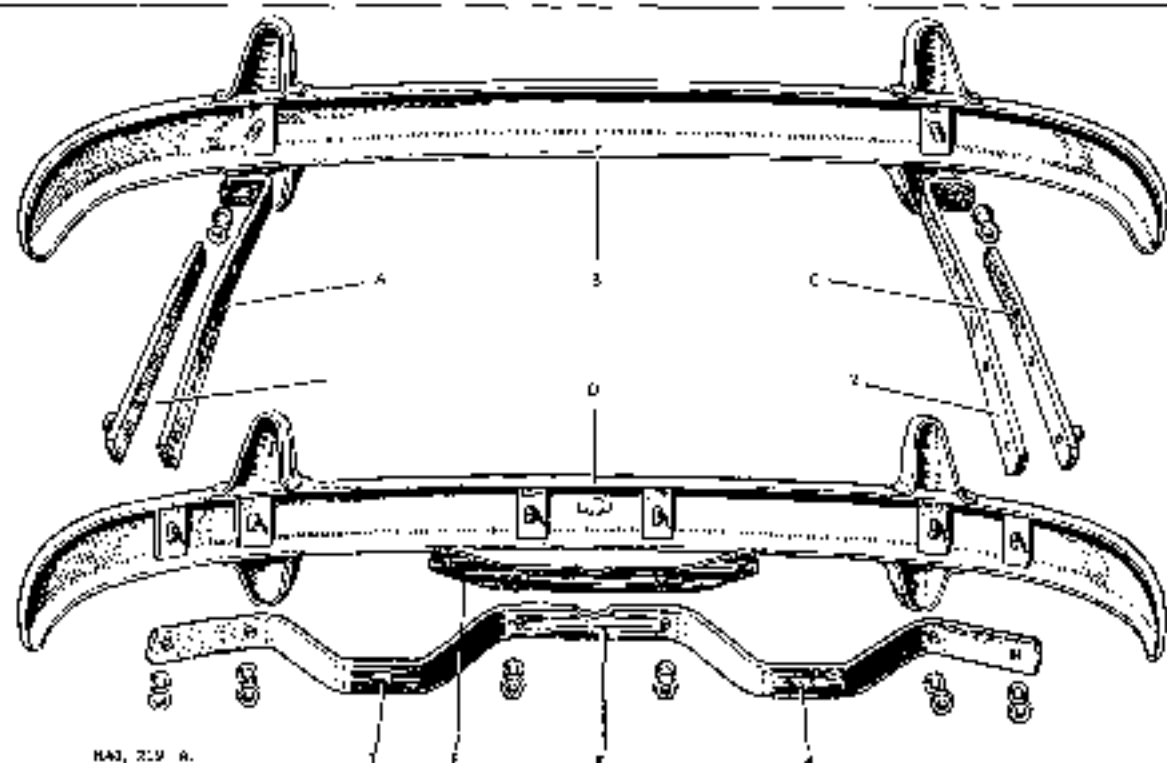

Fig. 24. The Fitch Plate.

1. Shroud securing points. 2 and 3. Scuttle securing points. 4. Radiator frame securing fixing points. 5. Front baffle fixing points.





H42, 219, B.

Fig. 25. Slanting the Bumpers and their Securing Hackets.

- |                    |                          |   |
|--------------------|--------------------------|---|
| A. Bumper main arm | D. Front bumper.         | 1. Screw thread setpin.                   |
| B. Rear bumper     | E. Number plate bracket. | 2. Plain holes for bolts.                 |
| C. Clamping arm    | F. Front bumper bracket. | 3 and 4. Main securing points to chassis. |

1. Disconnect the direction indicator cable. To do this first remove the small panel, provided for the purpose, in the door rear pillar. This panel is held in place by two metal thread screws.

2. If it is the left hand wing to be removed the petrol filler cap must be disconnected from its safety

wire. This is best achieved by releasing the small bracket on the under-side of the cap secured by two small screws.

At the front edge of the wing, inside the door pillar, five round head screws hold the wing in place.

Within the boot there are five setpins securing the top edge of the wing to the side panel, whilst the tail of the wing is fixed to the rear panel by three nuts and bolts.

Beneath the wing there are two nuts and bolts to be withdrawn from the stiffener bracket of the wheel arch and at the front there is a nut and bolt and one screw through the front bracket into the wheel arch.

#### Bumpers

**Front:** Unfasten the two brackets that hold the bumper to the chassis side member. On the steering gear side of the chassis the bumper bracket is held by two bolts, one long and one short, with nuts and washers, whereas on the other side the bracket is fixed by a short bolt, with nut and washer, and a long setpin.

**Rear:** If only the bumper is to be removed release the cap nut securing the bumper to each arm protruding through the body rear lower panel. However, if the arms have also to be removed the operator must undo the two nuts and bolts that fix each arm to the chassis extension brackets.

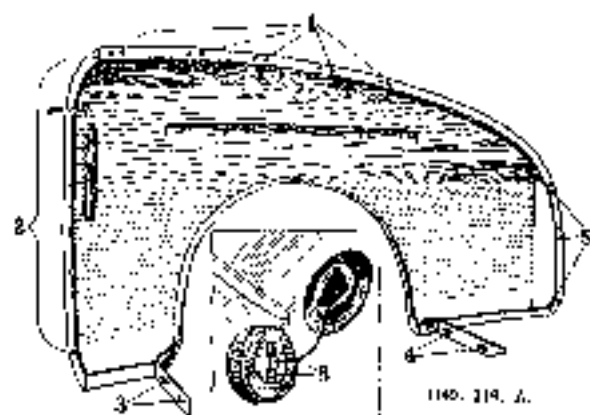

Fig. 26. Rear Wing.

1. Top large securing points.
2. Front edge fixing set screws.
3. Wheel arch front stiffener bolt slots.
4. Wheel arch rest stiffener bolt and setpin slots.
5. Bolt holes for securing wing tail.
6. Rivet shows filler cap releasing screws.

### Boot Lid

Remove the boot lid by undoing the single bolt, with nut and washer, which secures the supporting stay to the boot lid bracket. From each hinge, on the under side of the boot lid, unfasten the two nuts and take off the flat and spring washers when the lid can be lifted clear of the bodywork.

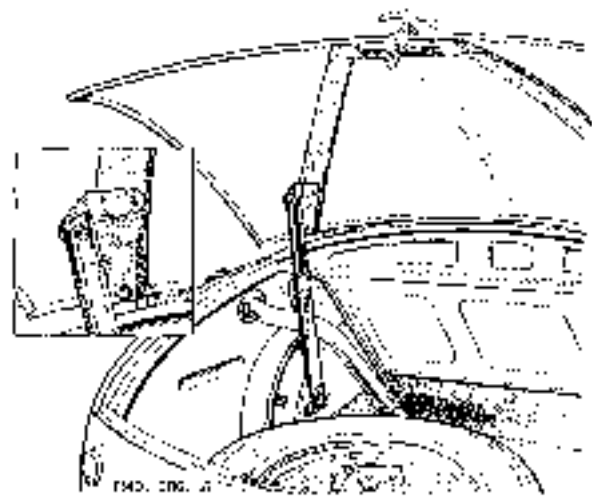

Fig. 27. Interior of the Boot showing the Hinge Nuts. Inset shows stay fixing to boot lid bracket.

### Rear Panel

Before attempting to detach the rear panel, remove the spare wheel by releasing its setpin and securing plate. Then extract eight metal thread screws, with cup washers, from the panel inner casing. Remove the casing and disconnect the wires to the twin stop and tail lights as well as those from the rear number plate illumination light.

Remove the rubber sealing strip from the top edge of the panel and drill out the thirteen "pop" rivets now exposed. From the bottom edge of the panel extract the three visible countersunk screws, with nuts and washers. Also from the bottom edge, drill out the ten "pop" rivets. Each side of the rear panel is secured to the body by three bolts, with nuts and washers. It is only necessary to slacken off these three bolts to release the rear panel from the body.

### Windscreen

The windscreen of the A40 Sports is secured in position by the Clatonite (Patented) Self Sealing Weather Strip. Owing to the shape of the windscreen frame the rubber seal has to be fitted in two parts, one piece for the bottom and the other for the sides and top of the frame. The installation of this seal requires the use of the makers' special tool, Fig. 29.

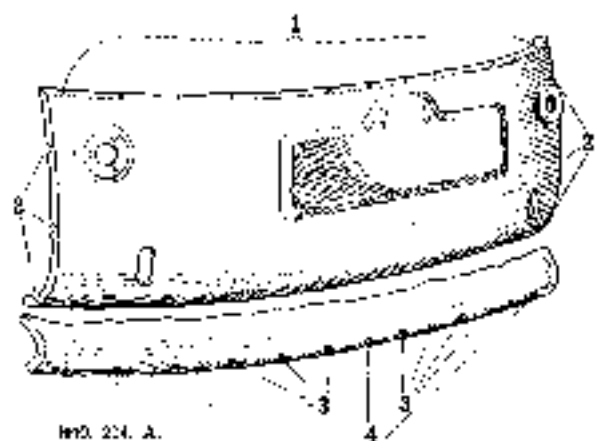

H40. 224. A.

Fig. 28. Rear Panel.

1. Holes in top flange for "pop" rivets. 2 Side securing points. 3. Bottom flange holes for "pop" rivets. 4. Countersunk screw holes.

When the broken pieces of the old windscreen have been removed, it will probably be necessary to remove the rubber seal owing to the small particles of glass remaining in the windscreen channel.

Before refitting the seal, first lubricate the edge of the windscreen frame with a solution of soap and water. If the original seal has been damaged in any way, a new

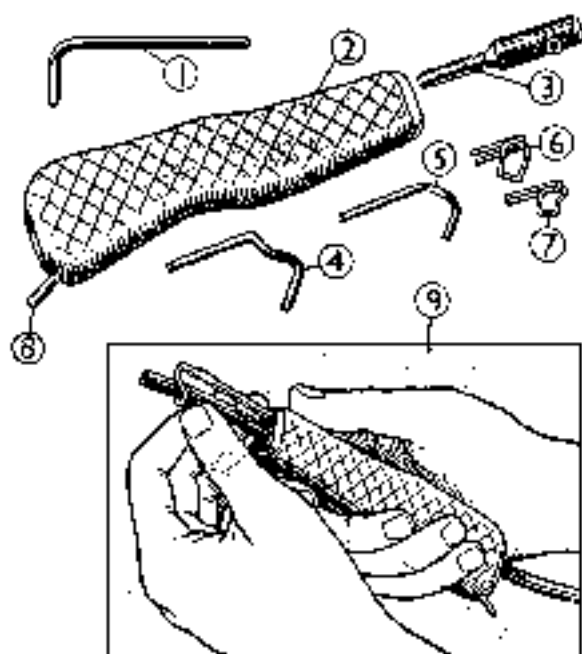

H40. 224. B.

Fig. 29. Tool Assembly.

- |   |                  |
|---|------------------|
| 1. Key                                      | 5. Hook (small). |
| 2. Handle                                   | 6. Eye (large).  |
| 3. Post                                     | 7. Eye (small).  |
| 4. Hook (large).                            | 8. Spur.         |
| 9. Inset showing threading of filler strip. |                  |

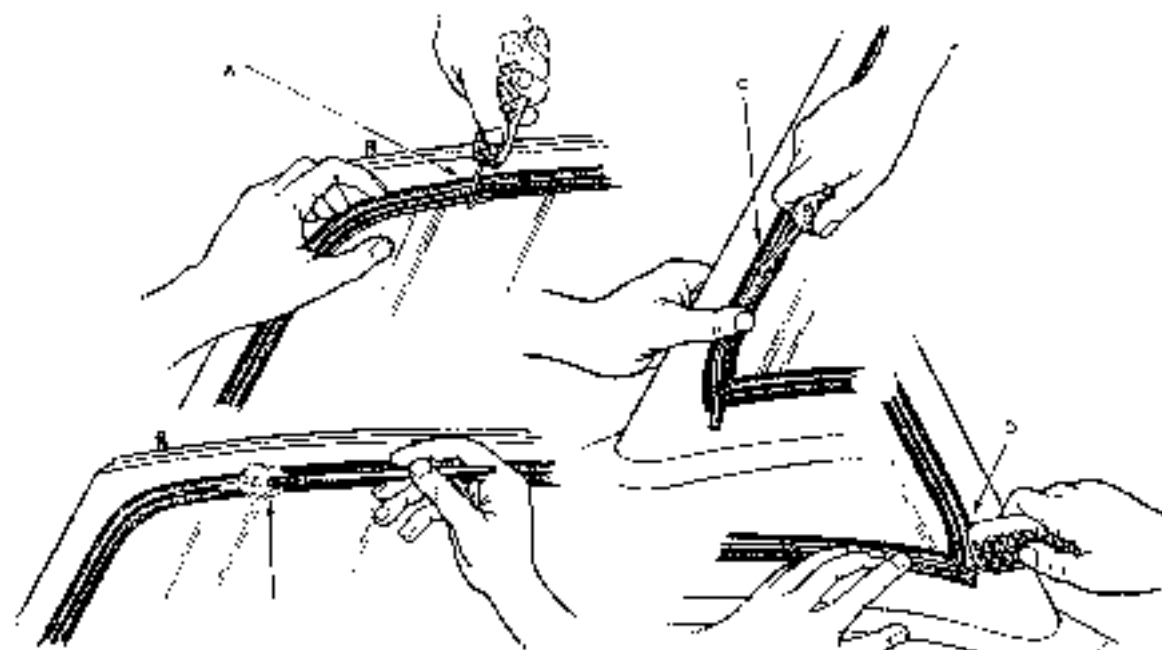

FIG. 30. A.

Fig. 30. Illustrating the fitting of the Chloride Seal.

- A Fitting the Windscreen into its channel.  
B Adjusting the filler strip channel

- C Inserting the filler strip.  
D Compressing the ends of the filler strip

one should be fitted. Allow an extra eighth of an inch for every estimated foot of seal required. This will ensure weatherproof joints and a good fit all round the

edge when the new windscreen is in position. Now fit the lower edge of the windscreen into its channel and, using the special installation tool, see A, Fig. 30, lift the channel lip and gradually work the windscreen into position.

With a small brush, apply a soap and water solution to the filler strip channel thus facilitating the entry of the filler strip. Again the makers' special tool will have to be used. Thread the filler strip through the handle and eye of the tool, insert the tool into the filler strip channel, as near as possible to one of the joints, and draw the tool round the top channel until the other joint is reached. Allow the filler strip to overlap two inches at both ends and with the spur on the tool handle, see D, Fig. 30, compress the overlapping filler strip into its channelling. In the same manner fit a length of filler strip to the bottom seal.

The ends of the filler strip must be fitted to the same angle as those of the main seal. This, together with the fact that the filler strip is under compression, ensures perfect weatherproof joints.

#### Fascia

Before attempting the removal of the fascia, by releasing the main fixings, the instrument and control knob panels should be detached.

First remove the control knobs. The choke and starter pull controls are screwed on to their spindles and held in position by locknuts. The heater control knob

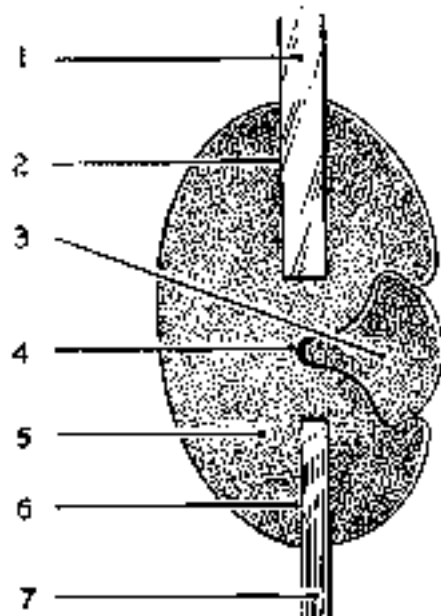
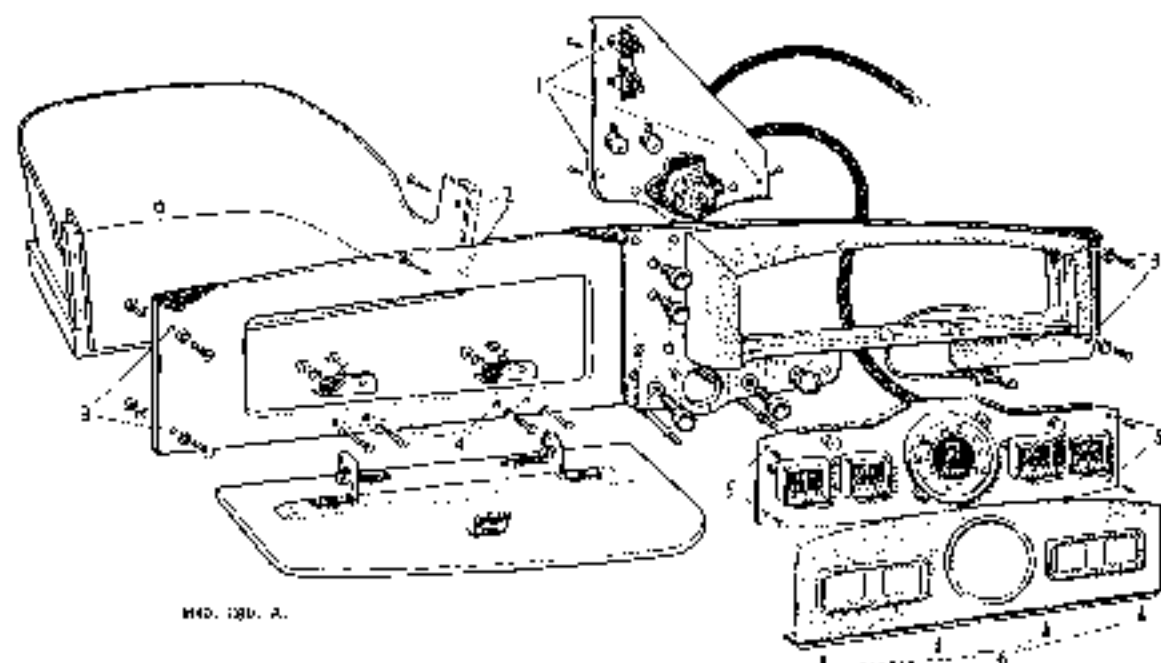

FIG. 31. B.

Fig. 31. Cross Section of Sealing Strip.

1. Windscreen 2. Windscreen channel 3. Filler strip.  
4. Filler strip channel 5. Main seal 6. Windscreen frame channel 7. Windscreen frame.



M40. 120. A.

Fig. 32. The Fascia.

- |  |                                    |                                       |
|--|------------------------------------|---------------------------------------|
| 1. Screws holding control knob panel   | 3. Side securing points of fascia. | 5. Fixing bolts for instrument panel. |
| 2. Screws securing glove box to fascia | 4. Glove box hinge bolts.          | 6. Cover panel securing screws.       |

is held by a grip screw, slacken it and remove the control knob, also unscrew the chrome ring securing the heater switch to the fascia. The remaining control knobs are held by spring-loaded plungers. The control knob panel is held in position by three screws, one each side and one above the ignition switch. See 1, Fig. 32. The removal of these, together with the control knobs, will free the panel from the fascia.

Detaching the instrument panel necessitates two operations. First, the panelling surrounding the instruments must be removed by releasing its four securing screws, located beneath its bottom edge, when the panel can be detached; then the four screws which hold the instrument panel frame to the fascia can be released. These screws are situated at each corner of the frame.

The main fixing points of the fascia can now be released. First remove the screws that hold the fascia panel top rail in place. Also detach the glove box lid by releasing four screws, see 4, Fig. 32, and the screws holding the glove box to the scuttle. Extract the two bolts, with nuts and washers, from each end of the fascia panel.

The fascia can be lifted clear of the bodywork and the glove box freed from the fascia by removing four screws.

#### Hood

To remove the hood, first lower it into its well behind the rear seat squab. Lift out the rear seat thus

giving access to the two rear seat side panels which are released by removing three screws from each panel.

The removal of the side panels exposes the hood securing bolts, there being two at each side. Remove these four bolts together with their wooden packing pieces and lift out the hood complete with linkage.

#### Doors and Windows

**Rear Window:** The rear window in the hood is of celluloid and is stitched to the fabric in its allotted position. Replacing a rear window entails cutting the securing stitches surrounding the windows, extracting the broken pieces of celluloid, then fitting the new window and restitching the fabric.

**Door Windows:** To replace a window glass, it is first necessary to remove the door inner casing complete with garnish rail. This operation necessitates the following procedure. Remove the single screw holding the small chrome plate to the rear top end of the door. From the front end of the leather garnish rail extract the single screw and cup washer. The three handles on the inside of the door should now be removed, details of the operation involved being given under the heading "Door Locks and Handles". Remove the two screws from the front edge of the casing together with the remaining screws that secure the carpet covered portion of the door inner casing. Now slide the casing forward and out of the rear lip of the door.

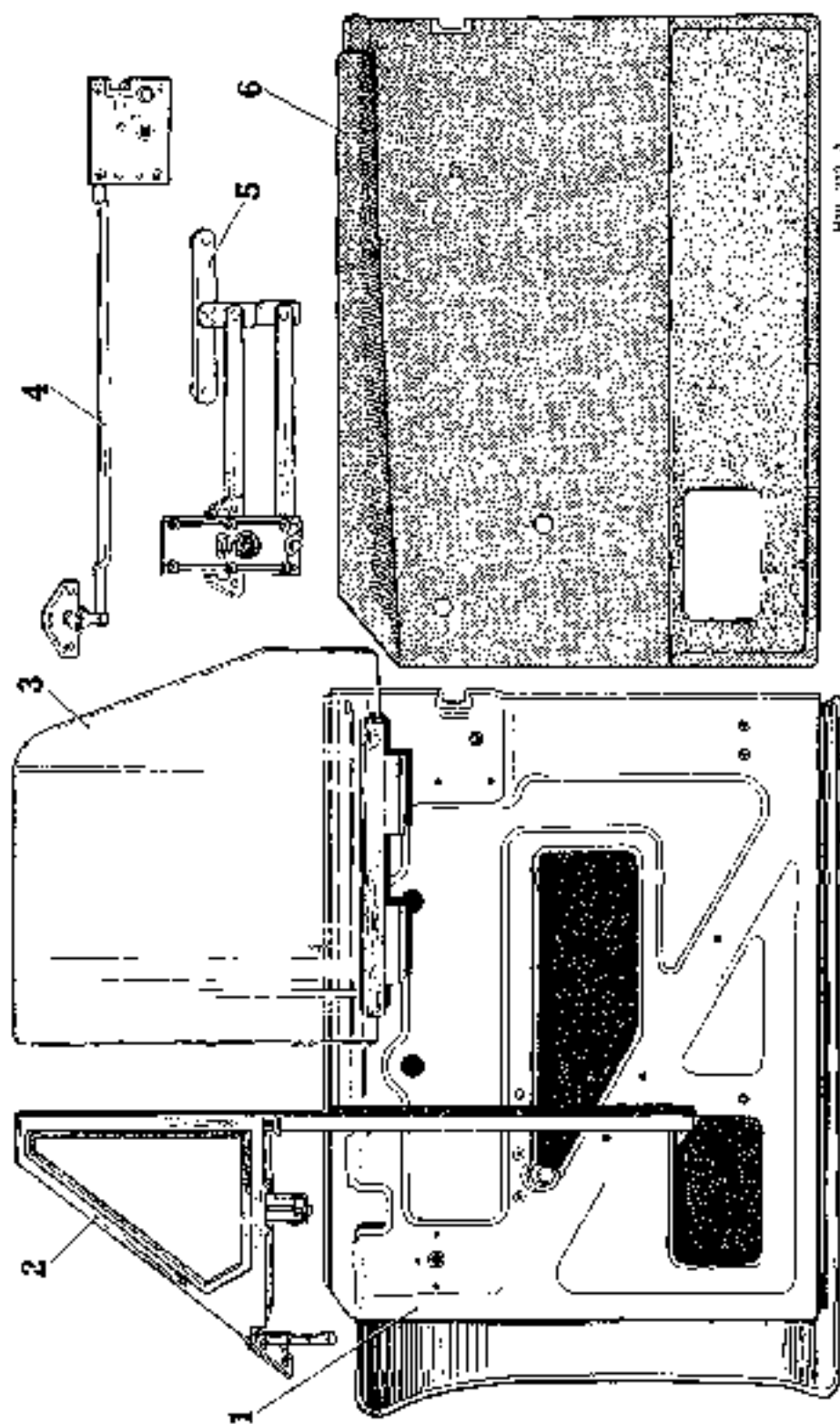

H80. 220. A.

Fig. 33. Exploded view of Door.

1. Door shell
2. Louvre assembly.
3. Window glass.
4. Door lock mechanism
5. Window winding mechanism.
6. Door inner casing.

Remove the window glass stop by releasing one setpin and washer, undo the two nuts and bolts that secure the window glass stop bracket to the metal casing and then extract the bracket. Now wind up the window to its full extent when it will be found that it can be lifted out quite easily.

To replace a window glass, lower it into the aperture in the top of the door, spring in the two rollers into their respective channels, which are attached to the pane of glass. Then complete the reassembly of the door by reversing the dismantling sequence.

The window winding mechanism can only be removed after the window glass has been taken out. Release the four setscrews holding the unit in position and manoeuvre it through the centre opening in the metal case.

**Louvre :** The ventilating window, or louvre as it is more often termed, should be removed in the following manner. Remove the metal thread screw from the door, and, as previously described, dismantle the door inner casing.

Release the four countersunk headed bolts, with nuts and washers, from the front edge of the louvre. The nut and bolt should now be removed which secures the window channel bracket, immediately below the louvre, to the metal panel. The door pocket is held in position by two screws, remove these and manoeuvre the pocket out of the door, thus giving access to the round headed setpin that secures the base of the window channel to its securing bracket.

Remove this setpin and lift out the louvre through the top of the door.

**Door Locks and Handles :** To remove the outer door handle, first take off the door inner casing and then extract a cheese headed screw from the end of the spindle. From outside the door, pull out the door handle complete with its spindle.

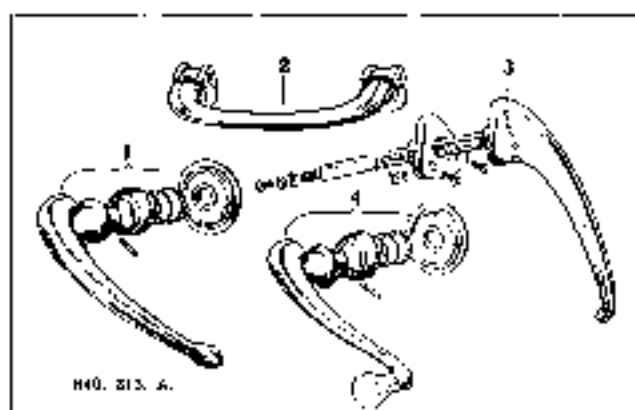

H40. 213. 4.

Fig. 35. Door Handles.

- 1 Lock of outer handle assembly
- 2 Door pull handle
- 3 Door outer handle
- 4 Window handle assembly

The inner door handle and the window winding handle are each removed by pressing back the chrome cupped washer against the plastic moulding and pushing out the handle securing peg, see Fig. 35. The handle can now be removed, together with the capped washer, spring and plastic moulding. The door closing handle is released by extracting two metal thread screws.

At its remote central end the door locking mechanism is held in position by three setscrews. Four setscrews hold the locking end of the mechanism, see Fig. 33, but, before attempting to remove the lock, first release all the door handles, the door inner casing, the window glass, its stop and stop bracket. Last of all, remove the pocket then the setpin securing the brass bracket which attaches the bottom of the window channel to the metal case. Lower the locking mechanism to the bottom of the door and manoeuvre it through the pocket opening.

**Door Removal :** There is no need to disturb the door hinges to remove the door. The door, as a precaution against mishandling and extraordinary road conditions, is secured to a carrier frame, see Fig. 34, the frame being hinged to the body.

To release the door from the carrier, first remove the door handles and the door inner casing. Release the small metal bracket that secures the front edge of the louvre to the carrier upright, see Fig. 33. Also, from this upright, withdraw one long and three short setpins, the long one goes through the door leading edge whilst the three short ones pass into the door inner skin. At the lower edge of the door, extract the two setscrews followed by the two setpins on the diagonal member of the frame.

The complete door can now be lifted from the carrier.

### Seating

The two front seats are of the adjustable, close fitting bucket type and slide in runners mounted on the chassis floor. To remove either seat, first lift out the

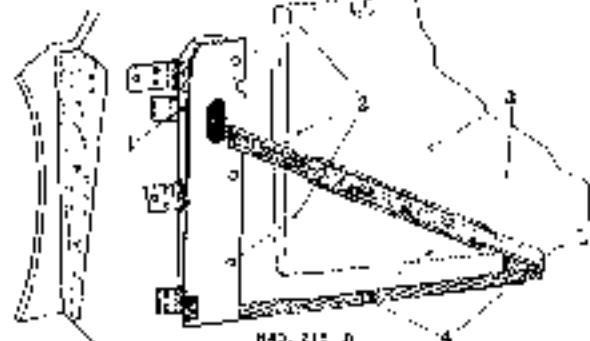

H40. 213. 5.

Fig. 34. Door Carrier Frame.

1. Hole for long setpin through leading edge of upright
2. Short setpin holes in upright
3. Frame diagonal securing points
4. Bottom edge fixing holes

seat cushion and then tip forward the backrest, release the locking handle and slide the seat rearward out of its runners. Each seat runner is secured to the floor by four screws.

The rear seat is of the "drop-in" type and is easily removed. To take out the rear seat squab, first release the pass stud fastening midway on the hood top. Tip the squab forward and withdraw two screws from each hinge at the base of the squab.

#### Heater

Before removing the heater, first drain the cooling system and then slacken off the two clips that secure the flexible hose to the two pipes protruding forward through the scuttle from the heater unit. Pull off the flexible hoses from these two pipes, disconnect the two electrical cables to the heater and release the two screws holding the de-mister piping to the rear of the heater. Before the unit can be fitted from its compartment, the plate immediately on top of it must be removed by undoing three bolts, with nuts and washers, and six set-screws. The heater is held in position by felt pads at top and bottom.

Full access to the de-mister pipes can only be obtained if the fascia is removed. The discharge vents, at the end of the de-mister pipes, are secured to the body by two self-tapping metal screws.

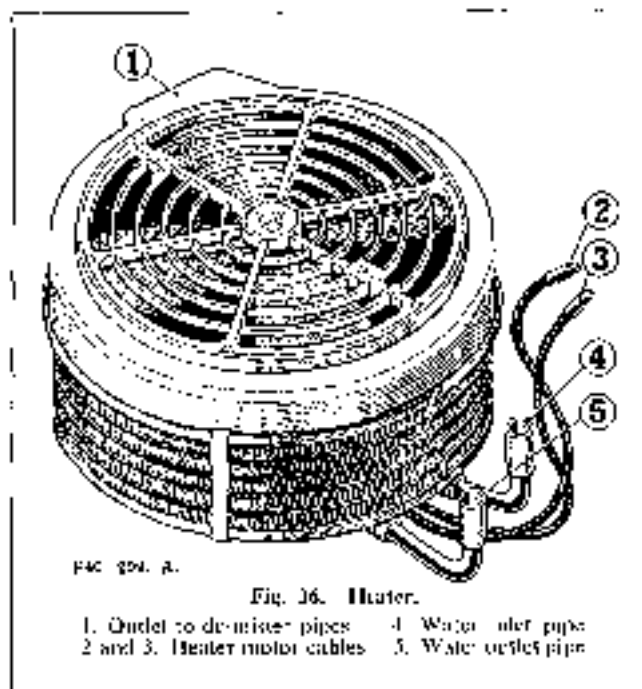

FIG. 36. A.

Fig. 36. Heater.

- |                              |                      |
|------------------------------|----------------------|
| 1. Outlet to de-mister pipes | 4. Water inlet pipe  |
| 2 and 3. Heater motor cables | 5. Water outlet pipe |

The heater motor bearings are packed with lubricant when the unit is first assembled and servicing should not normally be necessary as there are no other parts requiring attention.

## BODY REMOVAL

By adopting the following procedure, the A40 Sports body may be removed from its chassis.

(a) Remove the bonnet top and release the control cable at the catch. Release the battery terminals and lift out battery. Dismantle the harness for ease of working. Disconnect the snap connectors at the left-hand side of bulk plate and release the lighting harness from the radiator frame. Also release the snap connectors from the base of the steering column.

(b) Disconnect the following: thermometer bulb from the radiator, oil gauge flexible pipe from the engine block, high and low tension wires from the coil, throttle wire and choke cable from the carburettor linkage, brake fluid tank from the fitch plate and the leads from the dynamo.

(c) Detach the earth cable from the fitch plate. Disconnect the bottom cable from the starter switch and from its clip on the scuttle. Drain the cooling system then release the two water pipes at their heater unions.

(d) Pull out the tachometer control and take off the steering wheel. Having released the steering column

support bracket and the clip securing the handbrake remove the column and gear change (see page 3/5).

(e) Remove the seats, carpet and felt underlay. Strip off the sound insulating material glued to the floor.

(f) Unscrew the heads of the brake and clutch pedals and remove the toe boards. Five setpins and two metal thread screws hold the driving side toe board in position while five setpins and three metal thread screws secure the passenger side toe board. Release the shaft tunnel, covering the front universal joint of the propeller shaft, which is held by four screws. Also remove the gearbox rubber cover secured by twelve screws.

(g) Detach the floor plate on the driving side, held by four metal thread screws, the one on the passenger side is held by three screws. Remove all the metal thread screws that secure the body, the body side floors to the chassis and those that secure the body to the chassis along the front edge of the rear seat platform.

(h) Remove the rear bumper, complete with brackets. The front bumper need not be released. Drain

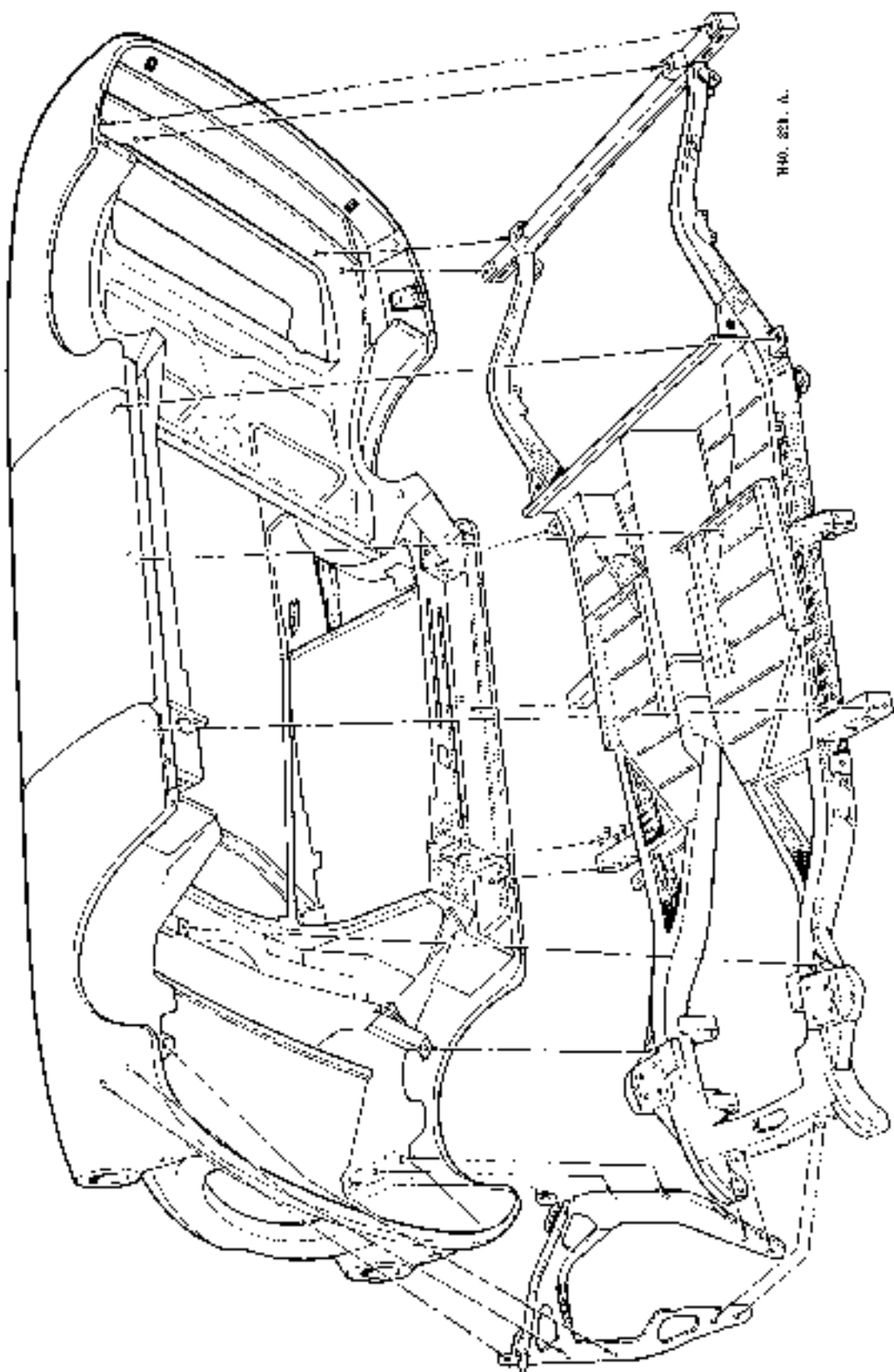

Fig. 37. Illustration of the Body in Chassis Strutting Points.

H40. 823. A.



The petrol tank and disconnect the feed pipe at the base of the tank. Release the wires to the rear lights, then extract the cables from the rear panel on the underside of the car. Disconnect the wire to the petrol tank gauge unit.

Following these preliminary operations, the body main securing points can now be released. These are clearly shown in Fig. 37, being the same at each side. Working from front to rear, release the two setpins and one nut and bolt securing the front baffle and fitch plate to the radiator frame. Withdraw the setpin that secures the scuttle bracing stay to a point immediately behind the front shock absorber mounting. From underneath

the car extract four nuts and bolts that pass through a body plate into the first chassis bracket and one nut and bolt, through the end of this bracket. With the door open, remove the rubber panel in the side of the body to gain access to the two setpins that screw into tapped holes in the second bracket.

Immediately in front of the rear seat release the nut and bolt passing through the third chassis bracket. From inside the boot remove the setpin and bolt that pass through the boot floor and chassis rear cross member. Employing a four point sling lift the body from the chassis using a vertical movement.

Reverse the above procedure for body refitting.







# SERVICE TOOLS

THE service tools listed in this section are those referred to in the text of the manual. Service efficiency is entirely dependent on the correct use of the right tool for the work in hand. The tools listed can be obtained from the Austin Service Department.

## ENGINE AND CLUTCH TOOLS

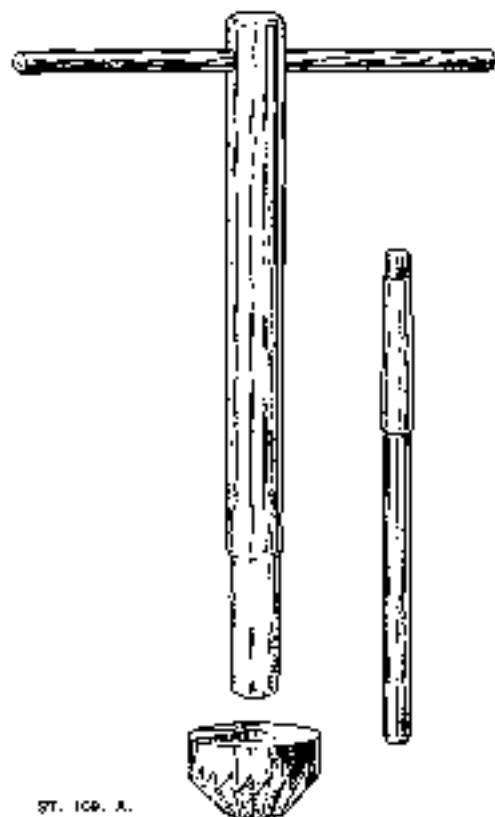

ST. 100. A.  
 Valve seat cutter  
 Piece . . . . . 13G 25  
 Handle . . . . . 13G 26  
 . . . . . 13G 27

Valve spring lifter . . . . . 13G 45  
 Tool illustrated on page D, 10.



ST. 108. A.  
 Water pump bearing drift . . . . . 13G 40

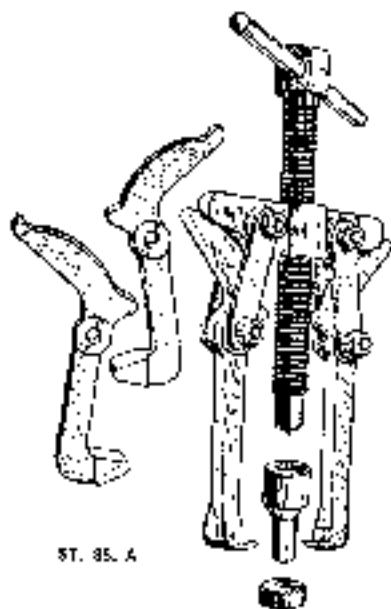

ST. 85. A  
 Crank gear extractor, fan and dynamo pulley  
 extractor . . . . . 13G 12



ST. 101. A,  
 Oil pump release valve grinding-in tool . . . . . 13G 69



ST. 105. A  
 Valve rocker bush drift . . . . . 13G 51

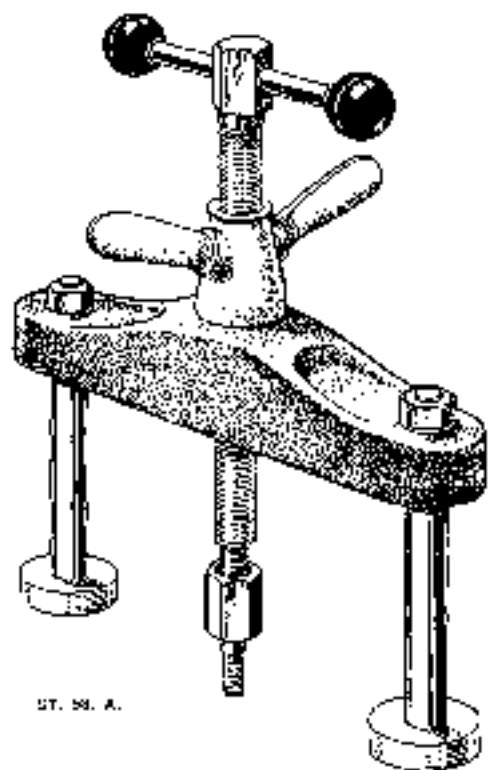

ST. 58, A.

Main bearing cup extractor ... 18G 42

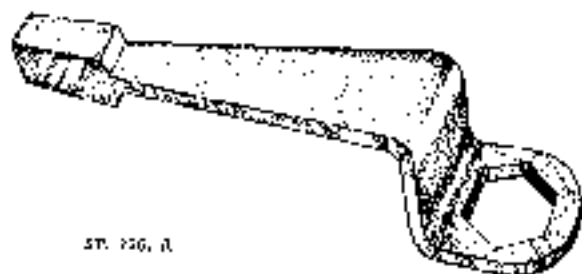

ST. 726, A.

Starting nut spanner ... 18G 58

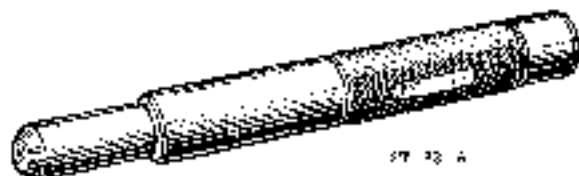
Valve seat insert extractor ... 18G 120  
Tool illustrated on page D, 13.

ST. 72, A.

Dummy first motion shaft ... 18G 70

Valve grinding-in tool ... 18G 29  
Tool illustrated on page D, 12

ST. 64, A.

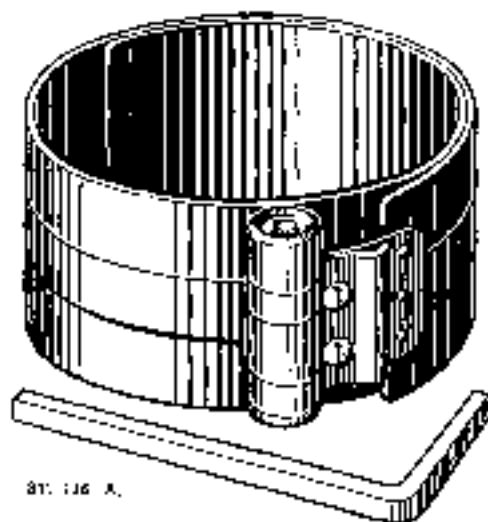
Crack gear drill, fan and dynamo pulley  
drift ... 18G 1Clutch assembly tool ... 18G 29  
Tool illustrated on page E, 3.

ST. 116, A.

Piston ring clamp ... 18G 75

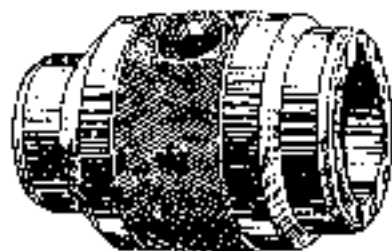

ST. 61, A.

Fuel cover locating tool ... 18G 3

## GEARBOX TOOLS



ST. 18. A.

First motion shaft nut spanner  
Front hub cap spanner

18G 5

Selector rod guide ... .. 18G 41  
Tool illustrated on page 1710.

First motion shaft assembly drift ... .. 18G 4  
Tool illustrated on page 1709.

Synchromesh assembly tool ... .. 18G 40  
Tool illustrated on page 173.



ST. 19. A.

Dummy keyshaft ... .. 18G 6

## FRONT SUSPENSION HUB TOOLS

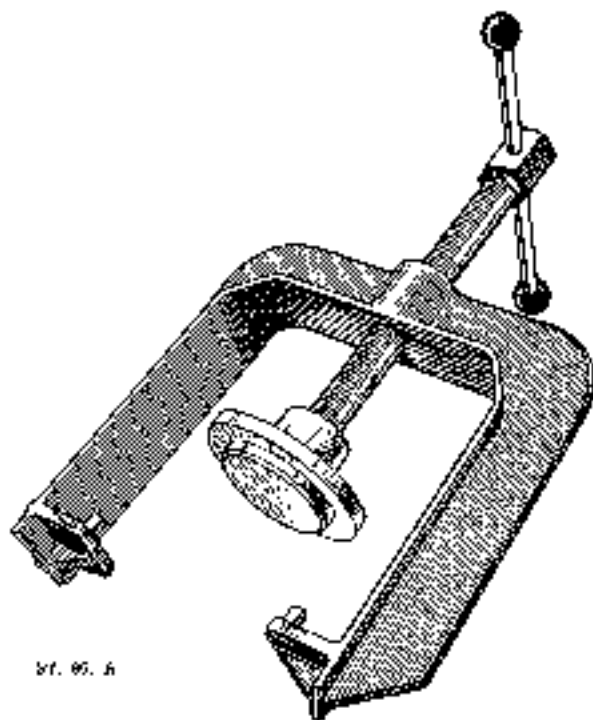

ST. 95. A

Coil spring compressor ... .. 18G 37

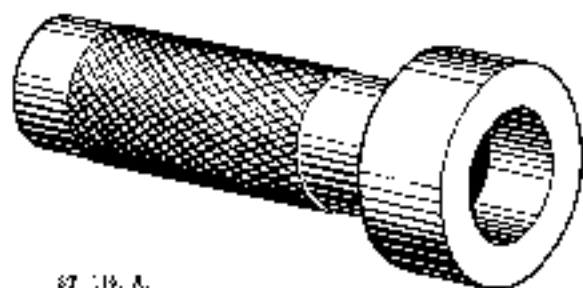

ST. 119. A.

Hub assembly and outer bearing drift ... .. 18G 15

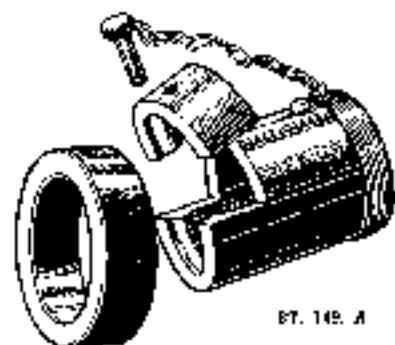

ST. 145. A

Front hub inner bearing race extractor  
(adaptor for use with L.T.R.) ... .. 18G 94

Front hub extractor ... .. 18G 8  
Tool illustrated on page 171.



ST. 109 A.

Wrench for swivel axle bush removal... 18G 68

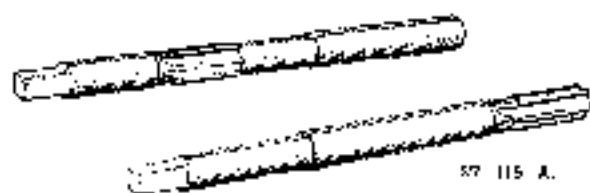

ST. 115 A.

Swivel axle bottom bush reamer 18G 69  
Swivel axle top bush reamer 18G 64

ST. 110 A.

Suspension checking plate 18G 56

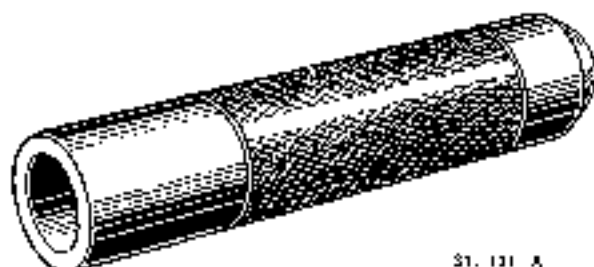

ST. 131 A.

Hub outer bearing remover 18G 7

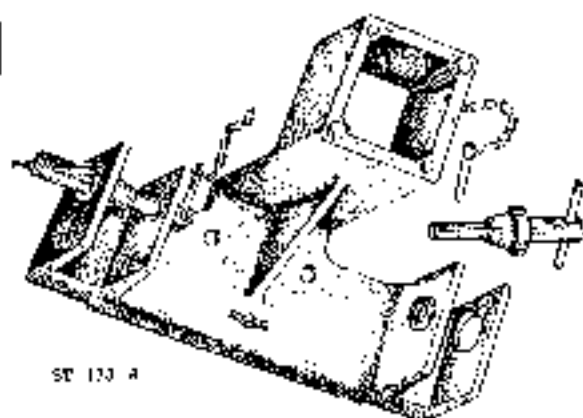

ST. 133 A.

Suspension assembly fixture 18G 89

## REAR AXLE TOOLS



ST. 52 A.

Rear hub spreader 18G 23



ST. 129 A.

Bevel pinion flange wrench  
Propeller shaft wrench... 18G 34Front and rear bevel pinion nut race remover  
and replacer 18G 82  
Tool illustrated on page K/5.Rear hub extractor 18G 10  
Tool illustrated on page K-1



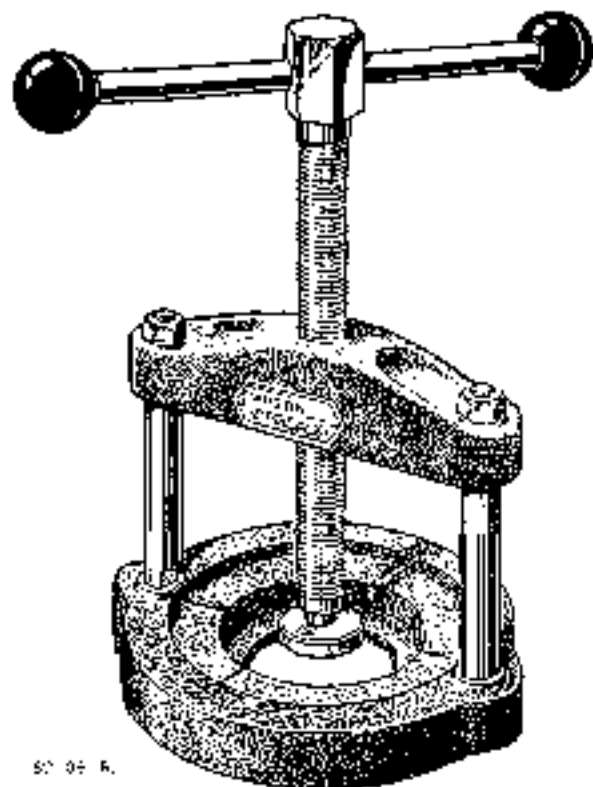

ST. 04 B.

Differential race bearing extractor . . . . . 18G 47

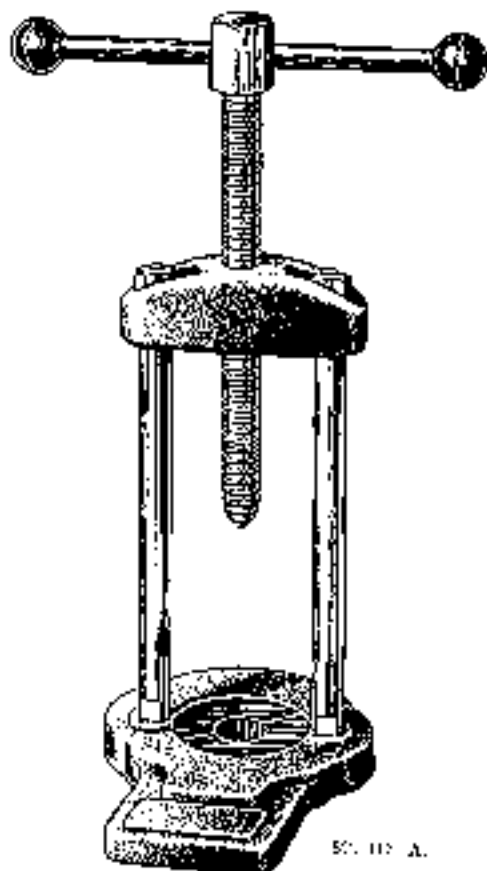

ST. 115 A.

Bevel pinion rear bearing inner race extractor and replacer . . . . . 18G 42

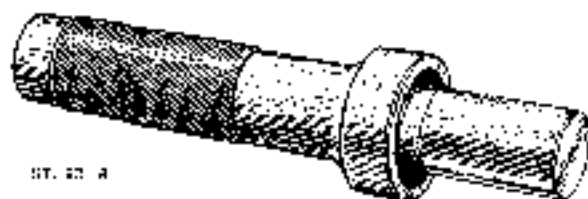

ST. 03 A

Bearing hub assembly and inner bearing drift . . . . . 18G 39

Bevel pinion flange drill . . . . . 18G 1  
See page Q:2.Bevel pinion flange extractor . . . . . 18G 2  
See page Q:1.

## STEERING AND CHASSIS TOOLS

Steering wheel extractor . . . . . 18G 70  
Tool illustrated on page J:7.Steering arm extractor . . . . . 18G 75  
Tool illustrated on page J:7.

## THE OIL GUN

**T**HE gun, as supplied, is used for forcing lubricant through the nipples. Charge the gun by unscrewing the end cap and fill to its capacity.

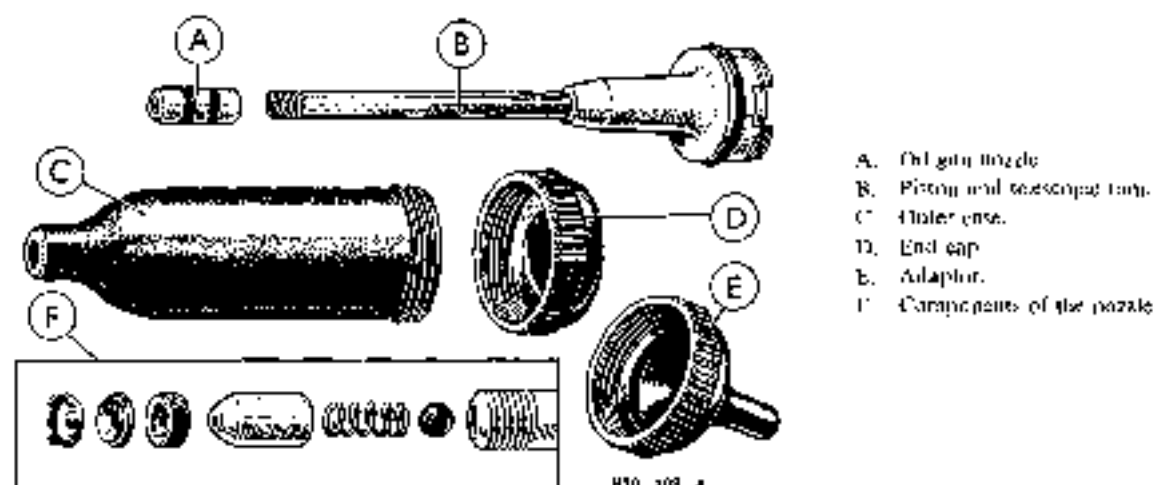

### Oiling technique

Always make sure that the nipple on the chassis component about to be lubricated is clean before applying the gun. Push the gun body hard and repeat the strokes according to the amount of lubricant required in the component. Wherever possible, watch for old oil exuding from the component concerned, since this is proof that the new is being forced in. A nipple which refuses to pass oil should be removed and cleaned. This is best achieved by leaving the nipple to soak for a short time in paraffin.

Should difficulty be experienced in the operation of the gun it is probably due to air locks. This can be easily overcome by carrying out the following procedure: -  
Extend the steel cylinder as far as possible, fill the gun

with the correct oil and replace the cap. hold the gun firmly in the left hand, unscrew the cap approximately two turns and then force the steel cylinder into the gun. This will force the oil to the top of the barrel and displace any air that may have been included in the filling process. the air can be heard distinctly coming out of the treads of the cap and when oil begins to emerge, the cap should then be tightened. After lubricating a point, it is most essential that the disconnecting process should be made with a sideways breaking movement and not pulled directly away; any attempt to disconnect it by pulling directly away will have a tendency to break the spring clip in the nozzle of the gun and at the same time to extend the cylinder, thereby sucking in air.

# PART NAME ALTERNATIVES

	Austin Part Name	Alternatives
Engine	Gudgeon Pin Scraper Ring Welch Plug Oil Sump	Piston Pin, Small End Pin, Wrist Pin Oil Control Ring Expansion Plug, Core Plug, Sealing Disc Oil Pan, Oil Reservoir
Controls	Choke	Strangler, Easy Starting Device
Gearbox	Gear Lever Change Speed Fork First Motion Shaft Layshaft	Shift Lever Shift Fork, Selector Fork Clutch Shaft, First Reduction Pinion, Main Drive Pinion Counter Shaft
Axle	Crown Wheel Bevel Pinion Spring Clips Axle Shaft	Ring Gear, Spiral Drive Gear Small Pinion, Spiral Drive Pinion "U" Bolts Half Shaft, Hub Driving Shaft, Jack Driving Shaft
Steering	Swivel Pin Swivel Axle Cross Tube Side Tube Steering Arm	Pivot Pin, Steering Pin, King Pin Stub Axle Tie Rod, Track Rod Drag Link, Steering Connecting Rod Drop Arm
Electrical	Dynamo Voltage Regulator	Generator Control Board, Cut Out, Voltage Controller
Exhaust	Muffler	Muffler
Body	Bonnet Mudguard	Hood Fender



## SERVICE FACILITIES

**T**HE following are the official addresses of the Austin Motor Company Limited and their Subsidiary Companies overseas, to whom all Service correspondence in these areas should be addressed. In all instances the enquirer is asked, first of all, to contact his nearest appointed Austin Distributor or Dealer before writing to one of the following addresses:

<b>England</b>	<b>THE AUSTIN MOTOR COMPANY LTD</b> Service Department, Longbridge, Birmingham, 31 Telephone: PRIORY 2101 Telegrams: SPEEDILY, NORTHFIELD Cable: SPEEDILY, BIRMINGHAM
<b>London</b>	<b>THE AUSTIN MOTOR COMPANY LTD</b> Holland Park Hall, Holland Park, London, W.11 Telephone: PARK 8000 Telegrams: AUSTINSERV, NOTTARCH
<b>U.S.A.</b>	<b>THE AUSTIN MOTOR COMPANY LTD (ENGLAND)</b> Central Parts Division, 2227-9 Webster Avenue, Bronx, 57, New York, N.Y. Telephone: CYPRESS R-4530 Telegrams: AUSTINMOTO, NEW YORK
<b>Canada</b>	<b>THE AUSTIN MOTOR COMPANY (CANADA) LTD</b> Service Division, Kenilworth Avenue North, Hamilton, Ontario Telephone: HAMILTON 4-2816 Telegrams: AUSTINETTE, HAMILTON
<b>Australia</b>	<b>THE AUSTIN MOTOR COMPANY (AUSTRALIA) LTD</b> Joynton Avenue, Zetland, Sydney, N.S.W. Telephone: FF 6321 Telegrams: AUSTINETTE, SYDNEY

The Austin Motor Co. Ltd. wish to make acknowledgements to—

Messrs. A. C. Sprague Sparking Plug Co. Ltd., Armstrong Patents Ltd., Girling Brake Co. Ltd., Borg and Beck Co. Ltd., Car Gears Ltd., Champion Sparking Plug Co. Ltd., Dunlop Rubber Co. Ltd., Hardy Spicer and Co. Ltd., Hubschero-Futson Manufacturing Co. Ltd., Joseph Lucas Ltd., Smith's Motor Accessories Ltd., Zenith Carburettor Co. Ltd. for their assistance in furnishing information and illustrations for this manual where required.









## Export Market

	Mobil	Shell	Walsfield	Esso	B.P.	Duckham's
* Engine	Mobilol A	Shell X.100, 30	Castrol Xc	Essoliche 30	Essojet Motor Oil S.A.E. 30	Duckham's "NOL THIRTY"
	Mobilol Avto	Shell X.100, 20	Castrol 10	Essoliche 20	Essojet Motor Oil S.A.E. 20 W	Duckham's "NOL TWENTY"
	Mobilol 10 W	Shell X.100, 10 W	Castrol Z	Essoliche 10	Essojet Motor Oil S.A.E. 10 W	Duckham's "NOL TEN"
Transmission*	Mobilube C. 90	Shell Dentax 90	Castrol S1	Esso Gear Oil S.A.E. 90	Energol Transmission Oil S.A.E. 90	Duckham's C.G. 90
Rear Axle	Mobilube G.X. 140	Shell Spirax 140 E.P.	Castrol Hi-Press	Esso X.P. Compound S.A.E. 140	Energol Transmission Oil E.P. S.A.E. 140	Duckham's NOL E.P.T. 140
	Mobilube G.X. 90	Shell Spirax 90 E.P.	Castrol Ultray	Esso X.P. Compound S.A.E. 90	Energol Transmission Oil E.P. S.A.E. 90	Duckham's NOL E.P.T. 90
Steering Box and Oil Nipples	Mobilube G.X. 140	Shell Spirax 140 E.P.	Castrol Hi-Press	Esso X.P. Compound S.A.E. 140	Energol Transmission Oil E.P. S.A.E. 140	Duckham's NOL E.P.T. 140
Front Wheel Hubs	Mobil Hub Grease	Shell Retrax A	Castrolense Heavy	Esso Bear-Up Grease	Energol Grease C1	Duckham's H B Grease
Distributor and Oil Can	Mobil Handy Oil	Shell X.100, 20	Walsfield Oil	Esso Handy Oil	Essojet Motor Oil S.A.E. 20 W	Duckham's "NOL TWENTY"
Upper Cylinder Lubrication	Mobil Upperlube	Shell Daxos 11	Walsfield Casello	Esso Upper Motor Lubricant	Energol C.C.L.	Duckham's Adosack
Laminated Springs	Mobil Spring Oil	Shell Daxos P	Castrol Penetrating Oil	Esso Penetrating Oil	Energol Penetrating Oil	Duckham's Laminant Liquid

\* Engine: Above 40°F. or for high speed driving at high temperatures use next heavier grade of oil.

† Transmission: For prevailing sub-zero (F) temperatures use S.A.E. 90 10W oil.

‡ Rear Axle and Steering: For prevailing sub-zero (F) temperatures use S.A.E. 90 L.P. Lubricant.

§ Oil Nipples: For high temperature climates the grease as shown for hubs can be used.

Use only the best Standard Brands for Hydraulic Brakes and Shock Absorbers.

# Home Market

	Mobil	Shell	Wakfield	Esso	B.P.	Duckham's
Engine	Mobiloil A	Shell X.100 20	Castrol XL	EssoLube 30	EssoLube S.A.E. 30	Duckham's "NOL THIRTY"
	Mobiloil Arctic	Shell X.100 20	Castrolite	EssoLube 20	EssoLube S.A.E. 20 W	Duckham's "NOL TWENTY"
Gearbox	Mobiloil H.B.	Shell X.100 40	Castrol XXL	EssoLube 40	EssoLube S.A.E. 40	Duckham's "NOL FORTY"
Rear Axle, Steering Box, and Oil Supplies	Mobilube GX 540	Shell Spirax 140 L.P.	Castrol Hi-Press	Esso Espec Compound 140	EssoLube S.A.E. 140	Duckham's NOL F.P.T. 140
Front Wheel Hubs	Mobil Hub Grease	Shell Remax A	Castrolite Heavy	Esso Grease	Esso Grease C.3	Duckham's H.B. Grease
Discbrake and Clutch	Mobil Handy Oil	Shell X.100 20	Wakfield Oilite	Esso Handy Oil	EssoLube S.A.E. 20 W	Duckham's "NOL TWENTY"
Upper Cylinder Lubrication	Mobil Upperlube	Shell Durax L.	Wakfield Castrolite	EssoLube	EssoLube U.C.L.	Duckham's Acknols
Laminated Springs	Mobil Spring Oil	Shell Durax P.	Castrol Penetrating Oil	Esso Penetrating Oil	Esso Penetrating Oil	Duckham's Laminator Liquid

Hydraulic Brakes:—Use Grease Brake Fluid (Consomonts only)  
 Spring Absorbers:—Use Armstrong's Super-Clutch Shock Absorber Oil

# "A40" SALOON & COMMERCIAL LUBRICATION CHART

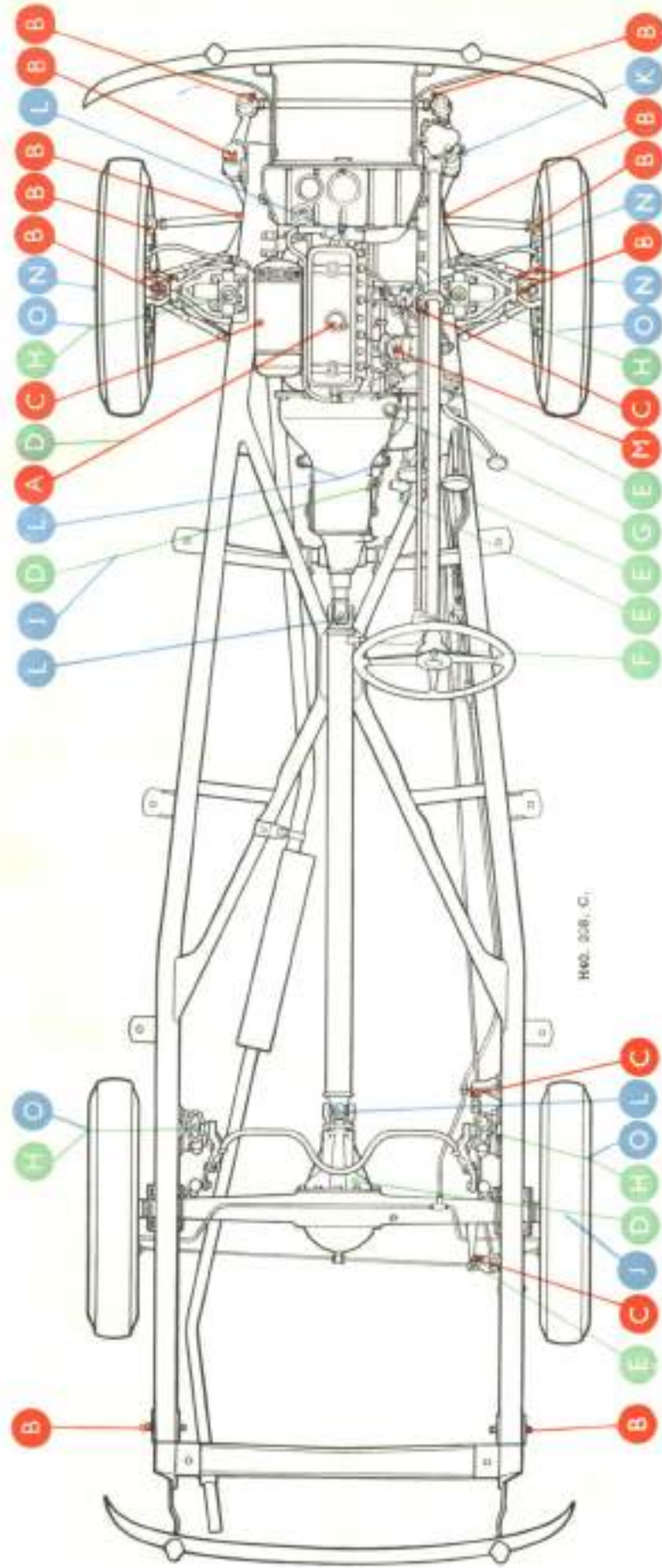

DO NOT SPRAY THE FRONT SUSPENSION WITH OIL OR PARAFFIN

## WEEKLY (500 MILES)

- |         |   |   |
|---------|---|---|
| Oil     | A | Top-up the Engine Reservoir.  |
| Oil Gun | B | Steering Connections (7), Swivel Axles (4), Front Suspension Lower Joint (2), Rear Spring Shackles (2). |
| Oil Can | C | Brake Linkage, Carburettor Control Joints, Gear Change Control Joints.                                  |

## MONTHLY (2,000 MILES)

- |         |   |  |
|---------|---|--|
| Oil     | D | Drain and refill Engine Reservoir.   |
| Oil Gun | E | Top-up the Gearbox and Rear Axle, Brake Balance Lever (1), Handbrake Pivot (1), Clutch Pedal (1), Brake Pedal (1). |
| Oil Can | F | Steering Column Top Bush.  |
| Oil Can | G | Brake Fluid Supply Tank Level.   |
| Examine | H | Front and Rear Shock Absorbers. Check for leaks.   |

## OCCASIONALLY

- |         |   |  |
|---------|---|--|
| Oil     | J | Drain and refill Gearbox and Rear Axle (5,000 miles).  |
| Oil Gun | K | Top-up the Steering Box (5,000 miles).   |
| Oil Gun | L | Universal Joints (2) (10,000 miles), Clutch Operating Shaft (2) (10,000 miles), Water Pump (10,000 miles). |
| Oil Can | M | Distributor (3,000 miles).   |
| Oil Can | N | Front Hubs (5,000 miles), Dynamo (10,000 miles) with H.M.P. grease.*                                       |
| Examine | O | Front and Rear Shock Absorber Fluid Levels (5,000 miles).  |

\* See Every 10,000 Miles—Dynamo Bearings Page XX.

Figures in brackets denote the number of nipples requiring attention

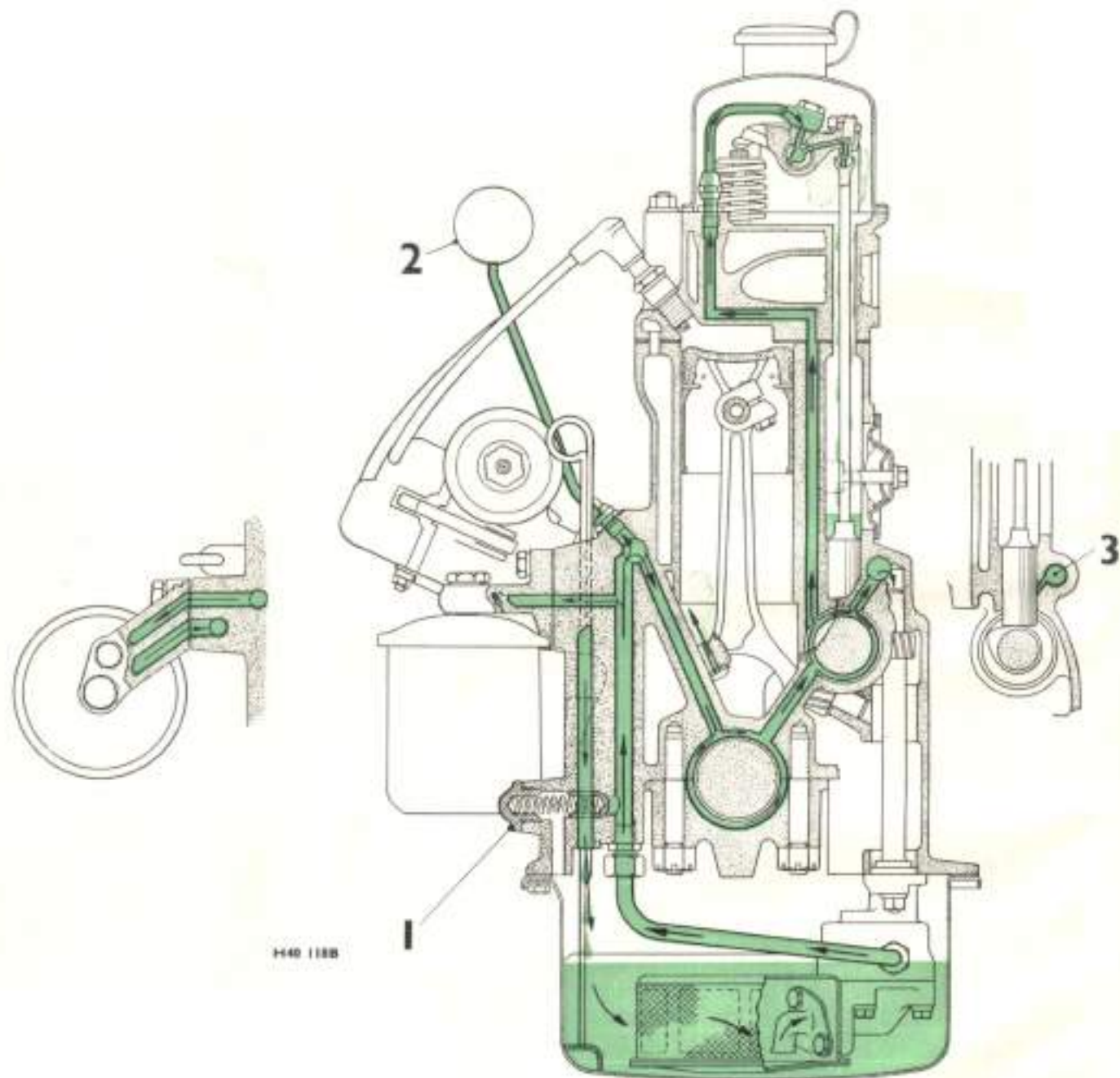

H40 1188

## ENGINE OIL

As may be seen from the illustration, oil from the sump is pumped to the gear and overhead valve mechanism. After circulation, surplus oil is

1. Release valve.      2. Oil pressure



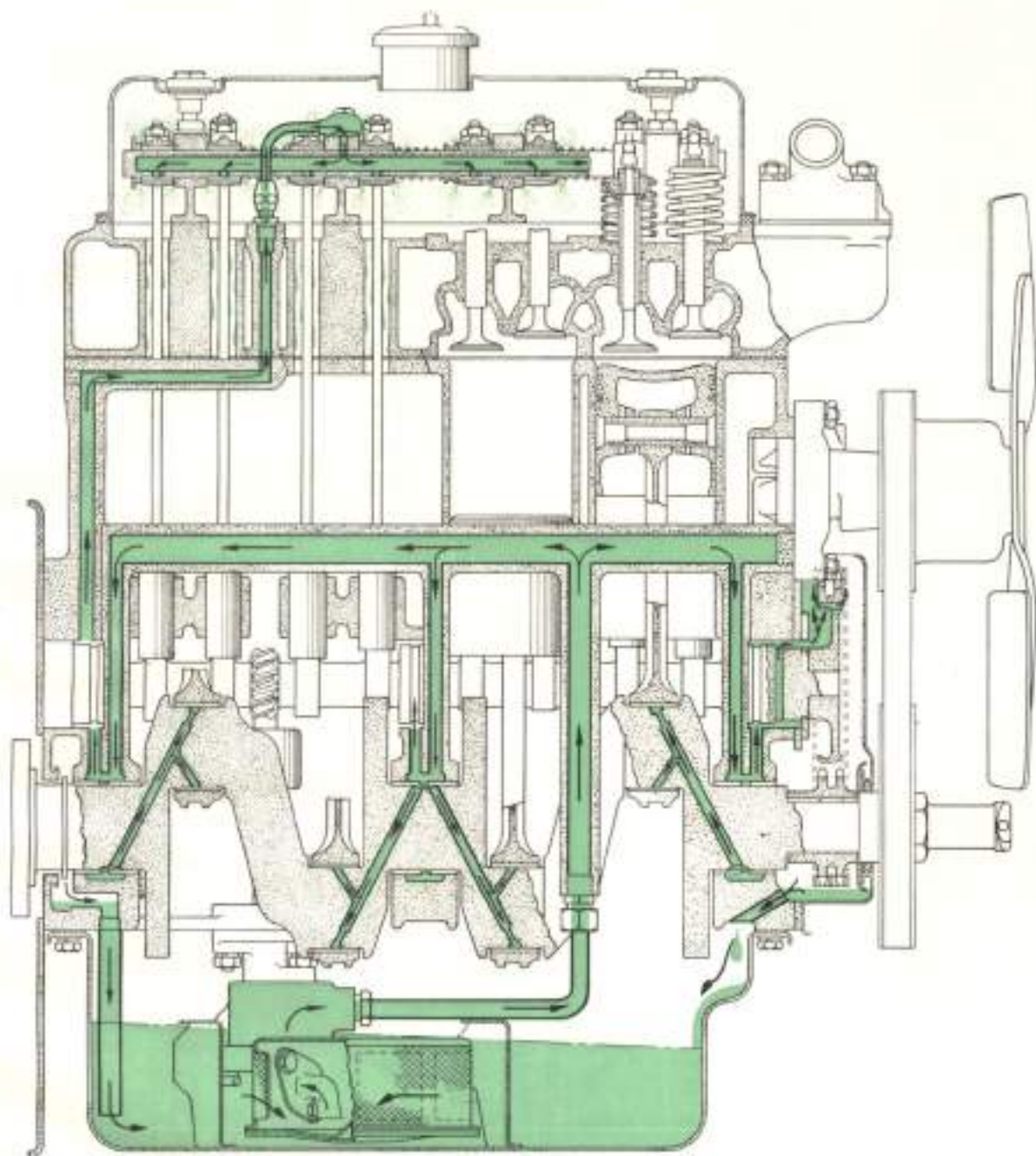

## CIRCULATION

through the by-pass filter to the various bearings, the camshaft  
drained from the rocker gear via the push rod holes to the sump.

gauge. 3. Oil feed to each tappet.

# "A40" SPORTS LUBRICATION CHART

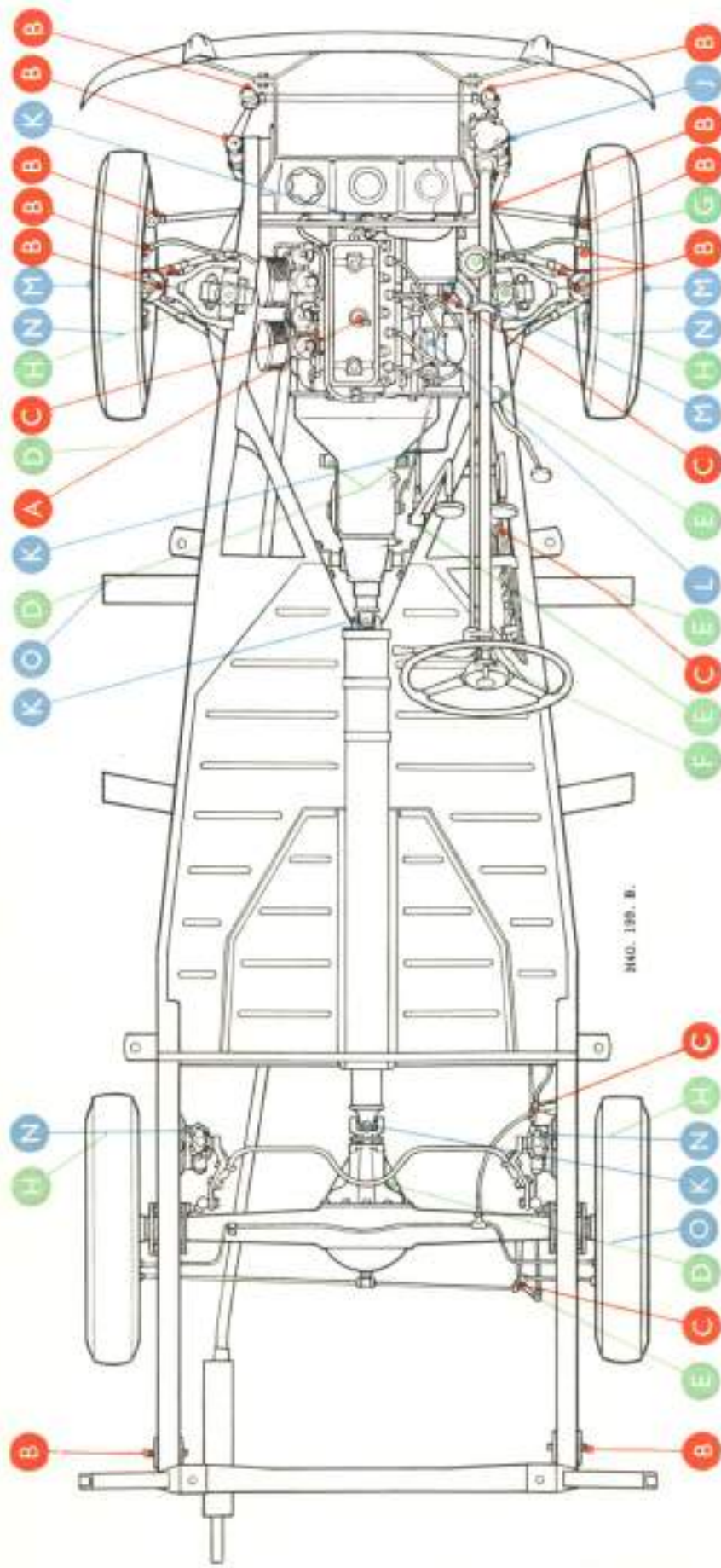

340. 199. B.

DO NOT SPRAY THE INDEPENDENT FRONT SUSPENSION WITH EITHER OIL OR PARAFFIN

WEEKLY (500 MILES)		MONTHLY (2,000 MILES)		OCCASIONALLY	
Oil	A	Oil	D	Oil	J
Oil Can	B	Oil Can	E	Oil Can	K
Oil Can	C	Oil Can	F	Oil Can	L
		Examine	G	Grease	M
			H	Examine	N
				Oil	O

- Top-up the Engine Reservoir.
- Steering Connections (7), Swivel Axles (4), Front Suspension Lower Joint (2), Rear Spring Shackles (2).
- Hand-brake, Pedal, and Carburettor Control Joints, Carburettor Piston Reservoir, Brake Linkage, Gear Change Control Joints.
- Drain and refill Engine Reservoir, Top-up the Gearbox and Rear Axle.
- Brake Balance Lever (1), Hand-brake Pivot (1), Clutch Pedal (1), Brake Pedal (1).
- Steering Column Top Bush.
- Brake Fluid Supply Tank Level, Front and Rear Shock Absorbers, Check for leaks.
- Top-up the Steering Box (5,000 miles).
- Universal Joints (2) (10,000 miles).
- Clutch Operating Shaft (2) (10,000 miles).
- Water Pump (10,000 miles).
- Distributor (10,000 miles).
- Front Hubs (5,000 miles).\*
- Dynamo (10,000 miles) with H.M.P. grease.
- Front and Rear Shock Absorber Fluid Levels (5,000 miles).
- Drain and refill Rear Axle and Gearbox (5,000 miles).

\* See Every 10,000 Miles—Dynamo Bearings Page XX.

Figures in brackets denote the number of nipples requiring attention



