

# LTE Network Extender User Guide

September 22, 2020

Version 1.7



## Table of Contents

---

<b>1</b>	<b>Getting Started</b> .....	<b>3</b>
1.1	Inside the Box.....	3
1.2	Your Network Extender.....	4
1.3	Reset Button .....	4
1.4	Requirements.....	4
1.5	Safety .....	5
1.6	Intellectual Property Rights .....	5
1.7	Open Source Software .....	5
1.8	Limited Warranty; Disclaimer of Other Warranties.....	5
<b>2</b>	<b>Setup</b> .....	<b>8</b>
2.1	Network Extender .....	8
2.1.1	LCD Display .....	10
2.2	GPS .....	11
2.3	Wall Mount (Optional Accessory).....	14
2.4	Making a Call.....	16
<b>3</b>	<b>Web Admin UI</b> .....	<b>17</b>
3.1	Admin Website Overview .....	17
3.2	Sign-In .....	19
3.3	Home .....	21
3.4	Connected Devices.....	22
3.5	Settings .....	24
3.5.1	Network.....	24
3.5.2	Advanced .....	26
3.5.3	Change Admin Password .....	28
3.5.4	Time Zone .....	30
3.5.5	Reset .....	31
3.6	About .....	32
3.6.1	Status & Alarms .....	32
3.6.2	GPS.....	34
3.6.3	Support.....	35
<b>4</b>	<b>Configuring Your Firewall</b> .....	<b>36</b>
<b>5</b>	<b>Troubleshooting</b> .....	<b>37</b>
5.1	Capacity & Network Coverage .....	38
5.2	LCD Display Messages & Error Codes.....	38

## 1 Getting Started

---

Thank you for purchasing a Verizon LTE Network Extender. Your LTE Network Extender provides enhanced 4G LTE network coverage for Verizon wireless mobile devices, with a capacity of up to 14 simultaneous active users (plus another channel reserved for 911 calls, and another for redirect purposes) and coverage radius up to 7500 square feet.

The LTE Network Extender is easy to install and works with existing Verizon mobile devices – simply connect the Network Extender to an existing broadband network. The Network Extender also features a built-in web server enabling IP settings to be customized. Please review this chapter to familiarize yourself with your device, and then follow the setup instructions in the next chapter.

### 1.1 Inside the Box

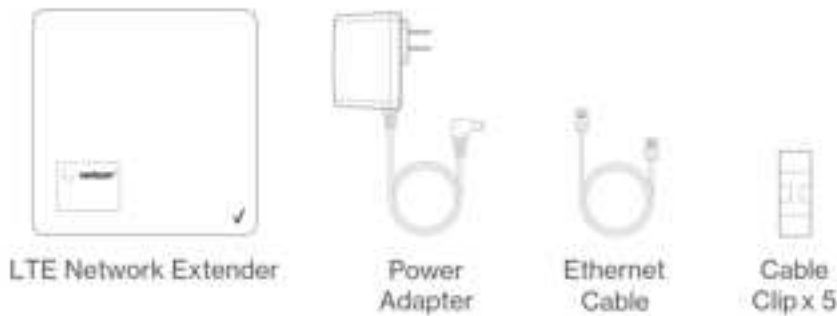

- LTE Network Extender
- Power Adapter
- Ethernet Cable
- Cable Clip x 5

### 1.2 Your Network Extender

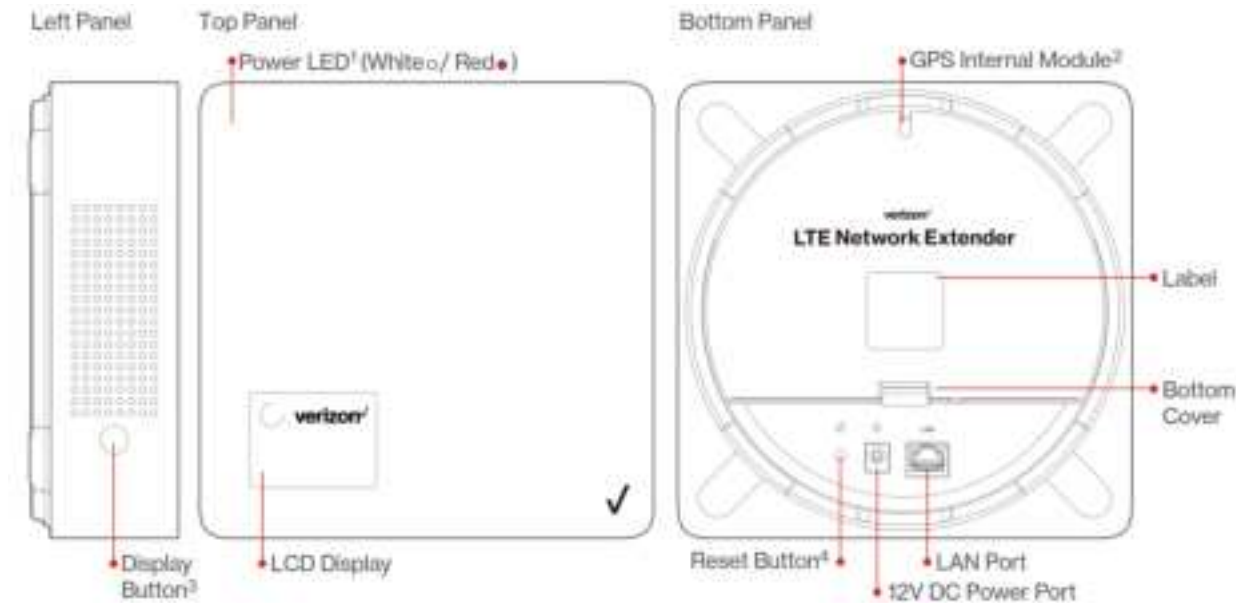

- The **Power LED** displays either white or red depending on device mode.
- The Network Extender features an **internal GPS module** that can be accessed by removing the **bottom cover**. Refer to Section 2.2 (GPS) for more information.
- The **LCD Display** shows status information regarding GPS satellites tracked and number of LTE devices connected.
- The **Display Button** toggles additional device information on the LCD display.

### 1.3 Reset Button

The Network Extender’s reset button is on the back of the device, and enables you to reset the device back to its original factory state. This can be useful for troubleshooting, resetting passwords, or if you experience any difficulty with your device. Performing a reset will reset **all settings and configurations (factory reset)**. To perform a reset, press and hold the reset button for at least 10 seconds, until the Power LED displays solid white, indicating a reset. Wait a few minutes for device to restart.

### 1.4 Requirements

- This device only supports Verizon Wireless 4G LTE mobile handsets with Advanced Calling turned on. Refer to Section 2.4 (Making a Call) for more information.
- The 4G LTE Network Extender must be connected to an available LAN port on a router or modem with always-on Internet access with a minimum download speed of 10 Mbps and an upload speed of 5 Mbps. Speeds of 20 Mbps download and 10 Mbps upload or higher are recommended.
- The 4G LTE Network Extender requires a continuous GPS signal from the provided GPS antenna. To find GPS at initial power up, four strong GPS satellite signals must be available. For better GPS signal strength, please pull out and unwrap 23’ GPS extension cable which is stored at the back of the Network Extender to position the GPS antenna as close to a window as possible. Refer to Section 2.2 (GPS).
- Home satellite broadband access is not supported.

## 1.5 Safety

-  This product contains chemicals known to the State of California to cause cancer and birth defects or reproductive harm. See [www.P65Warnings.ca.gov](http://www.P65Warnings.ca.gov).
- WARNING OF 911 LIMITATIONS: 911 or enhanced 911 services may be limited in areas outside of wireless network coverage. This device extends the reach of wireless network coverage in your area. Therefore, in the event of an electrical power outage, broadband connection failure, termination of broadband service or other service disruption, you may not be able to make 911 calls using this device. Always be prepared to report your location to public safety.
- FCC Radiation Exposure Statement: To ensure the safety of users, the FCC has established criteria for the amount of radio frequency energy various products may produce depending on their intended usage. This product has been tested and found to comply with the FCC's exposure criteria.
- The installation of the Network Extender should allow at least 8 inches between the device and persons to be in compliance with FCC RF exposure guidelines.
- Place your LTE Network Extender at least 10 feet away from products that generate electromagnetic radiation (e.g., microwave oven).
- Use only the included power adapter, using any other power source may damage the Network Extender.

## 1.6 Intellectual Property Rights

Verizon (or its licensors) owns exclusively and reserves all – and you may not exercise any – intellectual property rights in and to this product. You acknowledge and agree that the software and all ideas, methods, algorithms, formulae, processes, and concepts used in developing or incorporated into the product, all future updates and upgrades, and all other improvements, revisions, corrections, bug-fixes, hot-fixes, patches, modifications, enhancements, releases, and policy and database updates and other updates in, of, or to the software, all derivative works based upon any of the foregoing, and all copies of the foregoing are trade secrets and proprietary property of Verizon, having great commercial value to Verizon.

## 1.7 Open Source Software

Third party software may be included in or distributed with this product. Some software is expressly licensed only under the license terms indicated. Such software is licensed separately. Additionally, software whose license terms require separate licensing of the software under open source terms, including without limitation the LGPL, and the BSD, will be understood to be separately licensed under the relevant open source license. Refer to [https://www.askey.com.tw/upload/ASK-SFE116\\_Open\\_Source.pdf](https://www.askey.com.tw/upload/ASK-SFE116_Open_Source.pdf) for details.

## 1.8 Limited Warranty; Disclaimer of Other Warranties

Your Verizon Wireless LTE Network Extender has been designed to provide reliable, worry-free service. If for any reason, you have a problem with your equipment, please refer to the warranty in this section. For information regarding the terms and conditions of service for your LTE Network Extender, please visit [www.verizonwireless.com](http://www.verizonwireless.com) or call Verizon Wireless Customer Service at (800) 922-0204 or \*611 from your Verizon Wireless mobile phone.

### Standard Limited Warranty

What is Covered and For How Long?

What is Covered and For How Long Does This Converge Last?

Verizon Wireless ("Verizon") warrants to the original purchaser ("Purchaser") that the Verizon LTE Network Extender and accessories ("Products") and all components included in this package shall be free from defects in workmanship and materials under normal intended use and service for a period of one year following the date of purchase.

**What is Not Covered?**

This Limited Warranty is conditioned upon proper use of the Products by Purchaser. This Limited Warranty does not apply if anyone other than an authorized Verizon representative opens the casing for the Product, or if damage or failure is caused by misuse, abuse, neglect, accident, unusual physical, electrical or electromechanical stress, modifying the Product's components, or operating the Product in an unsuitable environment or in a manner for which it is not intended. This Limited Warranty also does not cover: (a) a Product that has the serial number removed or made illegible, physical damage to the surface of the Product, including, without limitation, breakage, cracks or scratches, dents or adhesive marks on the outside casing; or (b) malfunctions resulting from the use of the Product in conjunction with accessories, products, or ancillary/peripheral equipment not furnished or approved by Verizon; or (c) defects or damage from improper operation, maintenance, installation, or adjustment. Purchaser will be charged for all Product repairs for damage or failure not covered by this Limited Warranty. Please also note that if the Product used or purchased outside the United States or Canada, this Limited Warranty will not be applicable.

**What Verizon will do?**

Verizon's warranty applies only to the original Purchaser. If a Product is returned by Purchaser in an adequate container for shipping, accompanied by Purchaser's sales receipt or comparable substitute proof of sale showing the date of purchase, the serial number of Product and the sellers' name and address and within the applicable warranty period as described in this warranty information section, Verizon will, at its sole discretion, repair or replace the Product or its defective part. If you need assistance on where to deliver the Product, please contact Verizon Customer Care at (800) 922-0204 or \*611. Upon receipt, Verizon will repair or replace the defective Product within a reasonable period of time, unless covered by any exclusions indicated above.

Verizon will, at its sole option, provide one of the following remedies to whatever extent it shall deem necessary to satisfy a proper claim under this limited warranty: 1. Elect to repair or facilitate the repair of any defective components within a reasonable period of time, free of any charge, for the necessary parts and labor to complete the repair and restore the Product to its proper operating condition; 2. Replace Products with direct replacements. All repaired/replacement Products will be warranted for a period equal to the remainder of the original Limited Warranty on the original Product or for 90 days, whichever is longer. The replaced Products, parts, or components become the property of Verizon. Verizon retains the right to take the final decision of whether a warranty claim is justified. All above warranties are null and void if any Product is not covered by this Limited Warranty, the repair or replacement of Product shall be at the sole expense of the Purchaser.

**WHAT ARE THE LIMITS ON VERIZON'S WARRANTY/LIABILITY?**

TO THE MAXIMUM EXTENT PERMITTED BY LAW, THIS LIMITED WARRANTY AND THE REMEDIES SET FORTH ABOVE ARE EXCLUSIVE AND IN LIEU OF ALL OTHER WARRANTIES, REMEDIES AND CONDITIONS, WHETHER ORAL OR WRITTEN, EXPRESS OR IMPLIED. THE PRODUCTS ARE PROVIDED "AS IS" AND "AS AVAILABLE". VERIZON DISCLAIMS ALL EXPRESS AND IMPLIED WARRANTIES, CONDITIONS, REPRESENTATIONS, OR OTHER TERMS (INCLUDING AS TO SATISFACTORY QUALITY, FITNESS FOR A PARTICULAR PURPOSE, SUITABILITY OR MERCHANTABILITY). NEITHER VERIZON NOR ITS AFFILIATES, EMPLOYEES, AGENTS, SHALL BE LIABLE TO YOU, FOR ANY LOSS OR DAMAGE, INCLUDING WITHOUT LIMITATION LOSS OF PROFITS, INDIRECT, SPECIAL, PUNITIVE OR CONSEQUENTIAL LOSS OR DAMAGES ARISING OUT OF, OR IN CONNECTION WITH, THE PROVISION OR USE OF (OR ANY INABILITY TO USE) THE PRODUCT, WHETHER IN CONTRACT, TORT (INCLUDING

NEGLIGENCE), STATUTE OR OTHERWISE, EVEN IF ADVISED OF THE POSSIBILITY THEREOF. SOME COUNTRIES, DISTRICTS OR STATES DO NOT ALLOW THE EXCLUSION OR LIMITATION OF RELIEF, SPECIAL, INCIDENTAL, CONSEQUENTIAL OR INDIRECT DAMAGES, OR THE LIMITATION OF LIABILITY TO SPECIFIED AMOUNTS, SO THE ABOVE LIMITATIONS OR EXCLUSIONS MAY NOT APPLY TO YOU.

THIS WARRANTY GIVES YOU SPECIFIC LEGAL RIGHTS, AND YOU MAY ALSO HAVE OTHER RIGHTS, WHICH VARY FROM STATE TO STATE/PROVINCE TO PROVINCE. THIS LIMITED PRODUCT WARRANTY APPLIES ONLY TO THE ORIGINAL PURCHASER OF THE PRODUCT THAT WAS PURCHASED FROM AN AUTHORISED RESELLER OR SALES CHANNEL. IF ANY TERM CONTAINED HEREIN IS HELD TO BE ILLEGAL OR UNENFORCEABLE, THE LEGALITY OR ENFORCEABILITY OF THE REMAINING TERMS OF THIS LIMITED WARRANTY WHICH PURCHASER ACKNOWLEDGES IS AND WILL ALWAYS BE CONSTRUED TO BE LIMITED BY ITS TERMS OR AS LIMITED AS THE LAW PERMITS SHALL NOT BE AFFECTED OR IMPAIRED.

VERIZON DOES NOT WARRANT ANY THIRD PARTY EQUIPMENT OR SOFTWARE, EVEN IF INCLUDED WITH THE PRODUCT DISTRIBUTED BY VERIZON OR OTHERWISE. VERIZON PROVIDES ALL SUCH THIRD PARTY PRODUCTS AND SUPPORT AS-IS WITHOUT WARRANTY OF ANY KIND. RESPONSIBILITY FOR THE QUALITY, CAPABILITIES, OPERATIONS, PERFORMANCE AND SUITABILITY OF ANY SUCH THIRD PARTY EQUIPMENT OR SOFTWARE RESTS SOLELY WITH THE PURCHASER AND THE DIRECT VENDOR, OWNER OR SUPPLIER OF SUCH THIRD-PARTY EQUIPMENT OR SOFTWARE.

This Limited Warranty allocates the risks of product failure between Verizon and the original Purchaser, and is recognized by both parties and reflected in the price paid for the Products. This Limited Warranty is the entire and sole warranty applicable to the Products and cannot be modified or changed in scope or substance by any oral or written statements, information, or advice given by Verizon or any of Verizon's agents, employees, or others and may not rely on any such statements, information, or advice.

## 2 Setup

Your LTE Network Extender can be set up by following the procedures explained in this section. Before installing the LTE Network Extender, remember to confirm that all components are included in the package.

### 2.1 Network Extender

1. It is recommended to place the LTE Network Extender near a window or otherwise elevated location, such as on a bookshelf or cabinet, for best results. In addition, the attached cable clip can help you fix the GPS cable on the wall and then you can have GPS receiver close to the window easily.

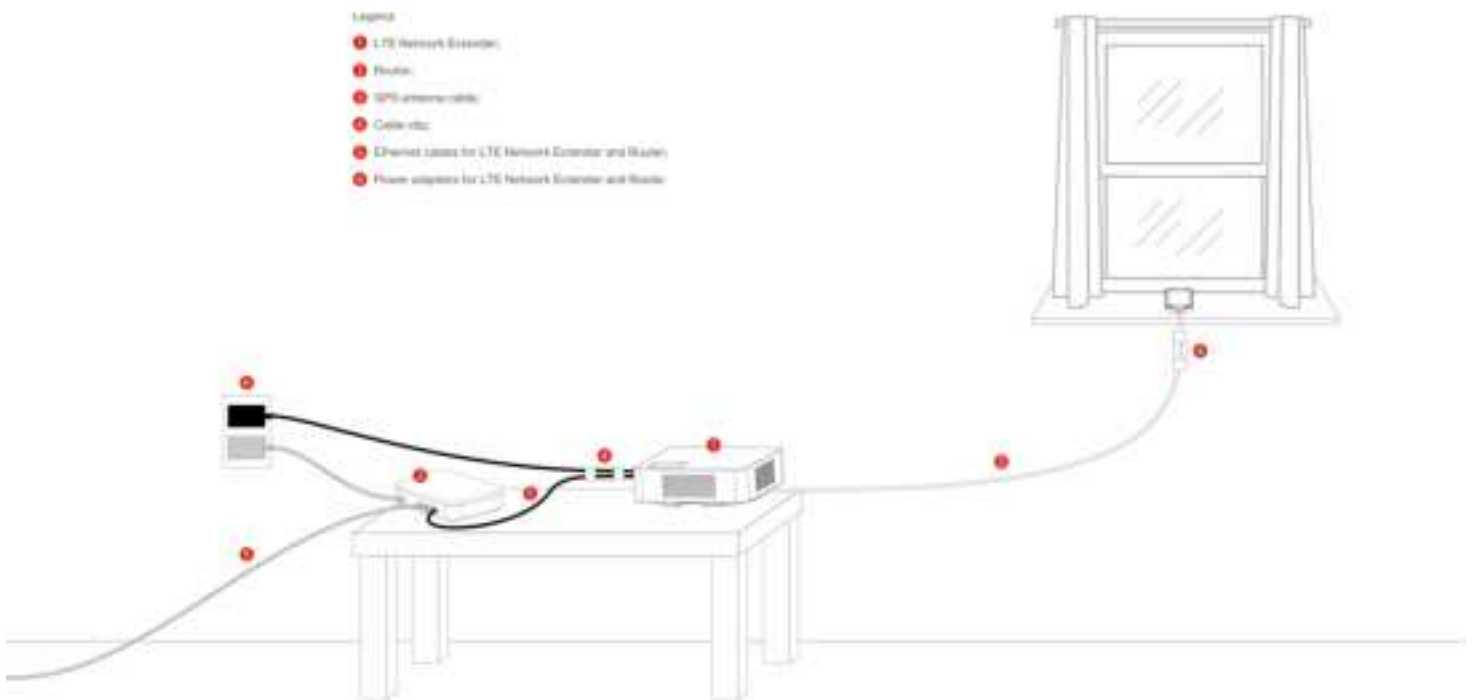

2. Using the provided Ethernet cable, connect an available LAN port on your router to the LAN port on your LTE Network Extender.

3. Connect the included power adapter to the LTE Network Extender’s DC 12V power port and plug the power adapter into an available power outlet. We recommend using the LTE Network Extender upright; however, it can also function well when the LTE Network Extender is in flat.

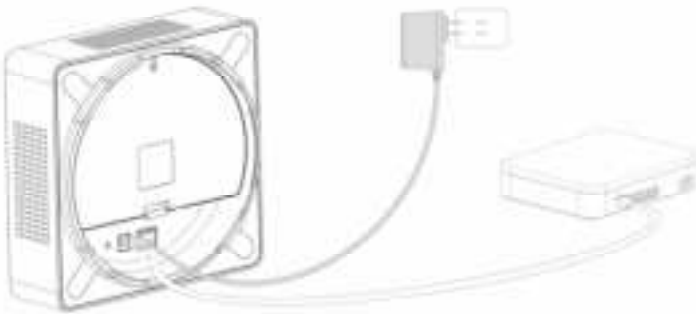

4. The Power LED should blink white when the LTE Network Extender is plugged in, to indicate the initialization and startup process. If the Power LED displays solid red, this indicates a hardware issue/problem.
5. The Network Extender will automatically begin the initialization and startup process after the power adaptor and the Ethernet cable are plugged in. This process may take 5 to 60 minutes depending on GPS signal conditions.



6. During this process, the LTE Network Extender will attempt to acquire a local IP address, followed by connecting to the Verizon network, and then searching for a GPS signal.

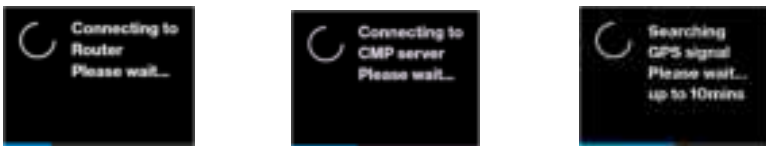

For proper operation and E911 service, a GPS signal is required. If a GPS signal is not acquired after 30 to 60 minutes, please refer to Section 2.2 (GPS). The GPS signal acquisition status can be checked using the Web Admin UI as shown in Section 3 (Web Admin UI).

7. To finish the startup process, the LTE Network Extender will download any necessary software updates and configuration data. When the startup process is complete, the Power LED will return to solid white and the LED Display will show “Service Active”.

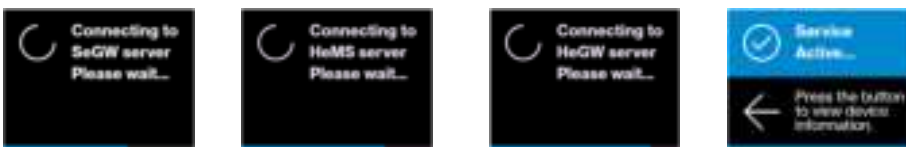

### 2.1.1 LCD Display

The LCD Display can display additional information: the LTE Network Extender IP address, MAC address, serial number, GPS Satellites connected, and mobile devices connected. Press the Display Button on the left panel of the Network Extender to toggle through information screens.

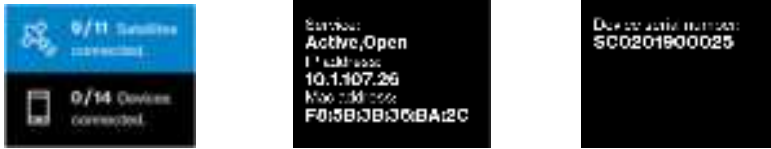

Refer to **5.2 (LCD Display Messages & Error Codes)** for more information on other messages or errors that the LCD may display.

## 2.2 GPS

If a GPS signal is not acquired after 30-60 minutes, you can use the internal GPS antenna to improve reception. It's recommended to position the GPS antenna beside a window. To take out and reposition the GPS antenna, follow the instructions below.

1. Turn off the LTE Network Extender.
2. Remove the rear cover on the 4G LTE Network Extender.
3. Take out the GPS antenna and unwrap the cable.
4. Return the plastic cable holder into place inside the Network Extender.
5. Reattach the rear cover.
6. Ensure that the GPS cable is running through the notch in order to properly fasten the rear cover back into place.
7. Place the antenna close to a window. If needed, you can use double-sided tape to secure the bottom of the GPS antenna in place, but take care not to cover the antenna with tape.
8. Turn your LTE Network Extender back on and wait for it to begin searching for a GPS signal. Four strong GPS satellite signals are required for a GPS location fix – the process may take up to 60 minutes.
9. If still encountering problems, check the GPS signal on the GPS page of the Web Admin UI. If you cannot verify that the Network Extender can consistently track 4 or more strong GPS satellite signals, then try another location for the GPS antenna where the signal may be better.

In below pictures, steps 1 to 6 show you how to unwrap the GPS antenna cable out of the LTE Network Extender; steps 7 to 13 show you how to wrap up the GPS antenna cable into the LTE Network Extender.





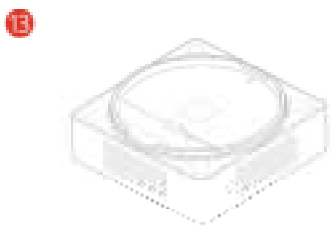
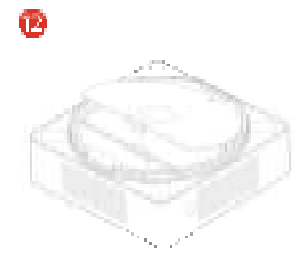
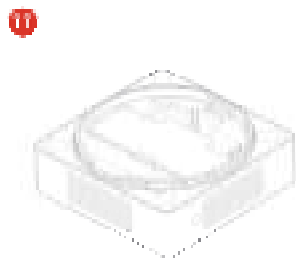
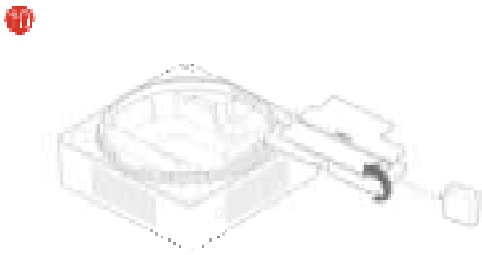
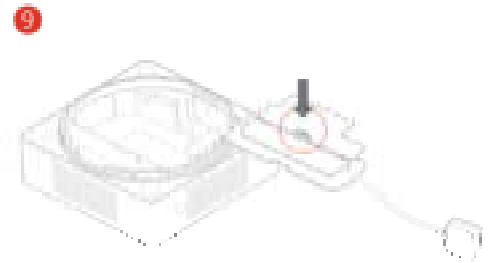
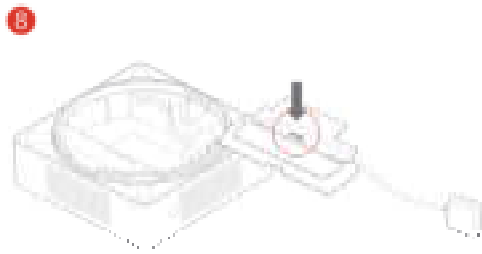

**2.3 Wall Mount (Optional Accessory)**

A separate wall-mount bracket package is available (sold separately) for your LTE Network Extender. This enables you to fix your Network Extender directly to a wall for better positioning.



1. Screw the included wall mount bracket into desired position on a wall securely, ensuring it's the correct way up (screws are included with the wall-mount). Recommended hole size for the conical plastic anchor is 0.25" in diameter and 1.20" in depth.



2. Make sure all cables are already connected to your 4G LTE Network Extender.



3. Align your Network Extender to the bracket (your Network Extender should be oriented with the LCD screen in the bottom left corner), and press firmly into place until it fits onto the bracket securely.



- The Network Extender can be slightly rotated on the wall mount bracket if needed.



## 2.4 Making a Call

When your Network Extender is operational, you can use it make calls with your Verizon mobile phone. To do so, your phone must be within 50 feet of the LTE Network Extender and have Advanced Calling switched on.

Advanced Calling settings vary according to operating systems:

- Android™: Go to Settings > Advanced Calling and turn on.
- Apple® iOS: Go to Settings > Cellular > Cellular Data Options > Enable LTE > Voice & Data. Additionally, on the “My Verizon” Mobile App, enable Advance Calling feature for your phones.
- Windows®: Go to Settings > Cellular + SIM > SIM settings and turn on Advanced Calling.
- On some devices, it may be found in Wireless Calling, HD Voice, VoLTE call or similar.

With Advanced Calling switched on, you can verify your Verizon phones are connected to the LTE Network Extender:

1. Dial #48 from your mobile phone
2. You should hear the following confirmation: “You are under LTE Network Extender coverage”
3. Some phones may show a home icon when connected to the LTE Network Extender.

The LTE Network Extender’s coverage can vary according to environmental factors, interference and strength of external cell towers.

### 3 Web Admin UI

The LTE Network Extender Web Admin UI enables you to configure features, see the device’s status and make changes to settings.

Using a computer connected to the same network (same router) as the LTE Network Extender, follow the steps below to access the Web Admin UI:

1. Toggle information on the Network Extender’s LCD Display by pressing the Display Button (left panel), until you see your Network Extender’s IP address displayed.
2. Enter the IP address into the address bar of a web browser e.g. http://<LTE Network Extender IP Address>.
3. You will arrive to the Web Admin UI Home screen as shown in the next section.

#### 3.1 Admin Website Overview

The Web Admin UI provides detailed status information and access to a range of functions and settings. Use the main menu on the left side to navigate. When you navigate to another page, or click the Sign In icon, you will be prompted to Sign In as shown in the next section.

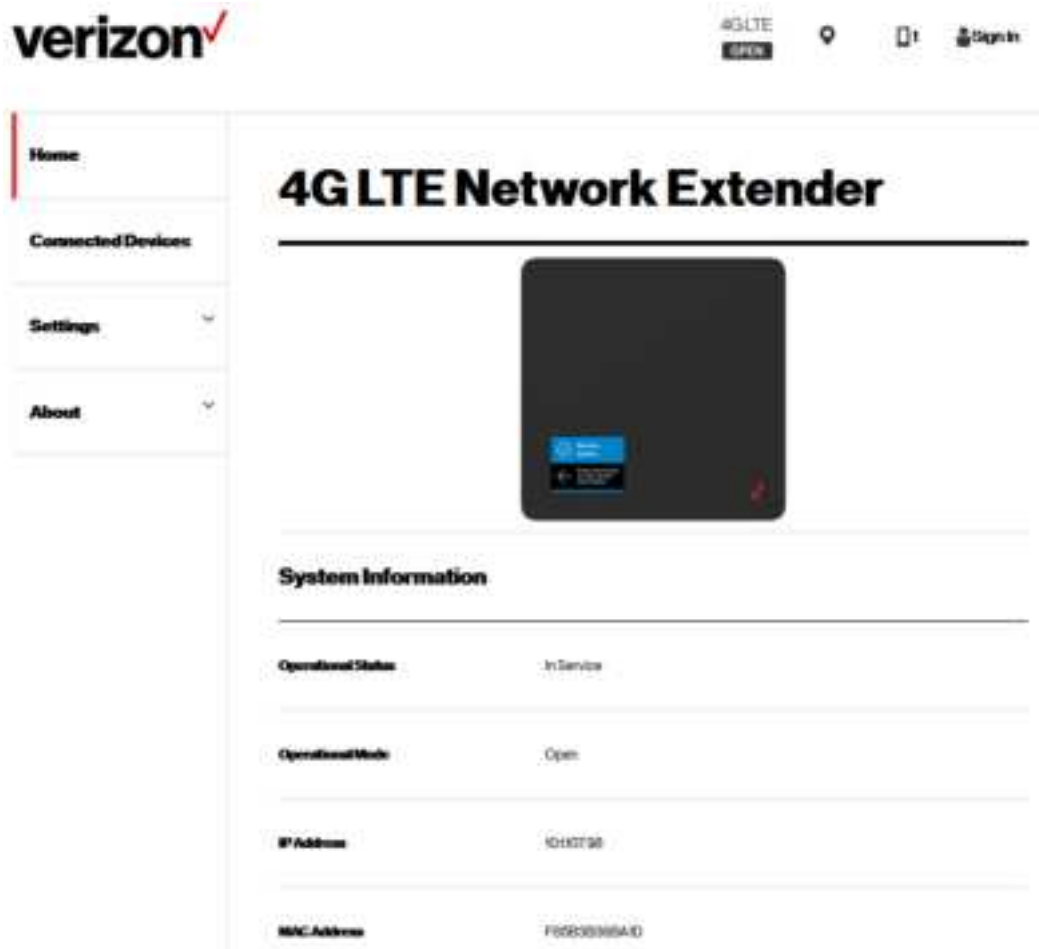

Icons in the top right corner of the Home screen provide a quick display of 4G Service Status, GPS Status, Connected Devices and Sign In Status.



 : GPS Lock Status

 : GPS Un-Lock Status

### 3.2 Sign-In

When you arrive to the Web Admin UI, you will need to sign in with the admin password to continue. You'll be prompted to sign in when you attempt to navigate to another page, or when you click the Sign-In icon in the top right.

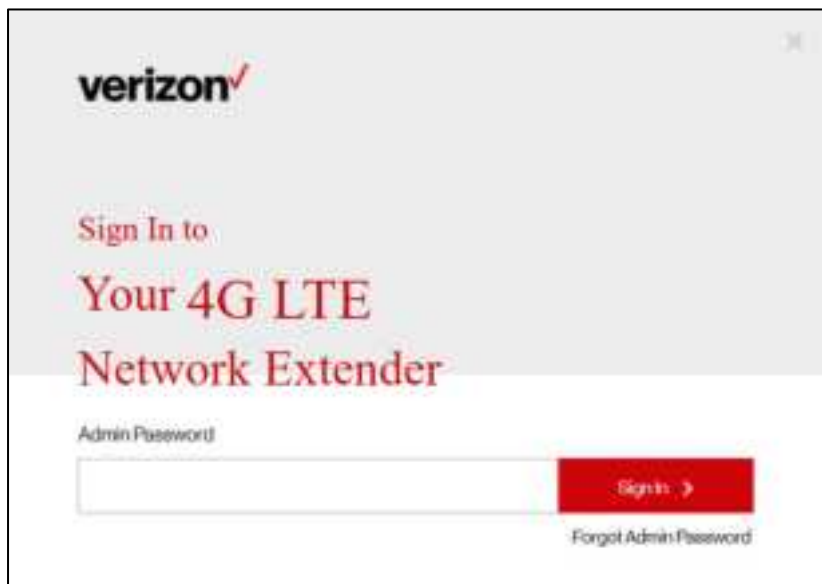

1. Enter the admin password and click Sign In. The default admin password is LTEFemto + last 4 digits of the Network Extender's unique MAC ID (e.g., LTEFemtoBED0). You can find your Network Extender's MAC ID displayed on the label on the back of the device as shown below:

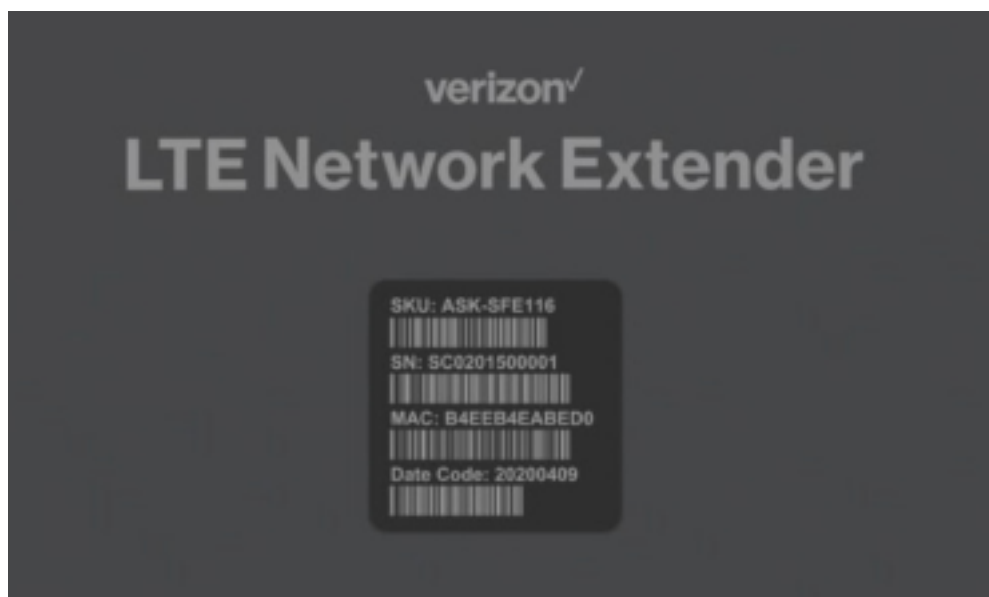

2. If you already changed the password and have forgotten it, use the Forgot Admin Password link. You will be prompted with the Security Challenge Question, which when answered correctly, will reset the password back to default.



Please note that passwords are case-sensitive – the last four digits of the MAC ID should be entered in UPPER case.

You can change the default password in Settings > Change Admin Password (**3.5.3 - Change Admin Password**). You may set up a Security Challenge question and answer.

You can reset the password back to the default admin password anytime if needed, by resetting your Network Extender back to its factory default settings. This resets all settings back to factory default state. Refer to Section **1.3 (Reset Button)** for more information.

### 3.3 Home

The Home page displays an overview of your Network Extender’s basic information, such as Operational Status, IP Address and MAC Address and others.

System Information	
Operational Status	In Service
Operational Mode	Open
IP Address	IPv4: 10.107.21 IPv6: FE80:0000:0000:0000:F45B:38FF:FE38:BA1D
MAC Address	F8005B38BA1D
Software Version	V04.000.4792
Location	(Source: GPS) <a href="#">Map</a> Latitude: 24.99954 Longitude: -81.487770 <a href="#">GPS Details</a>

**System Information**

Operational Status	Current operational status of the LTE Network Extender.
Operational Mode	Current operational mode (Open, Hybrid, or Closed) of the LTE Network Extender.
IP Address	The Internet Protocol (IP) address of the LTE Network Extender.
MAC Address	Displays the MAC address of the Network Extender. The MAC address is a unique hardware identifier used to identify a device in a network. This MAC address can also be found on the back label of the LTE Network Extender.
Software Version	Displays the software version of the Network Extender.
Location	Displays the GPS coordinates acquired by the Network Extender’s GPS antenna. This is the physical location of the LTE Network Extender and is provided for E911 calls.
Map	Links to the GPS location (above) on Bing Maps. Requires GPS Status to be “Location Acquired” (Refer to Section 3.6.2 - GPS).

**3.4 Connected Devices**

The Connected Devices page displays information about connected devices (phone, tablets, or other 4G LTE devices).

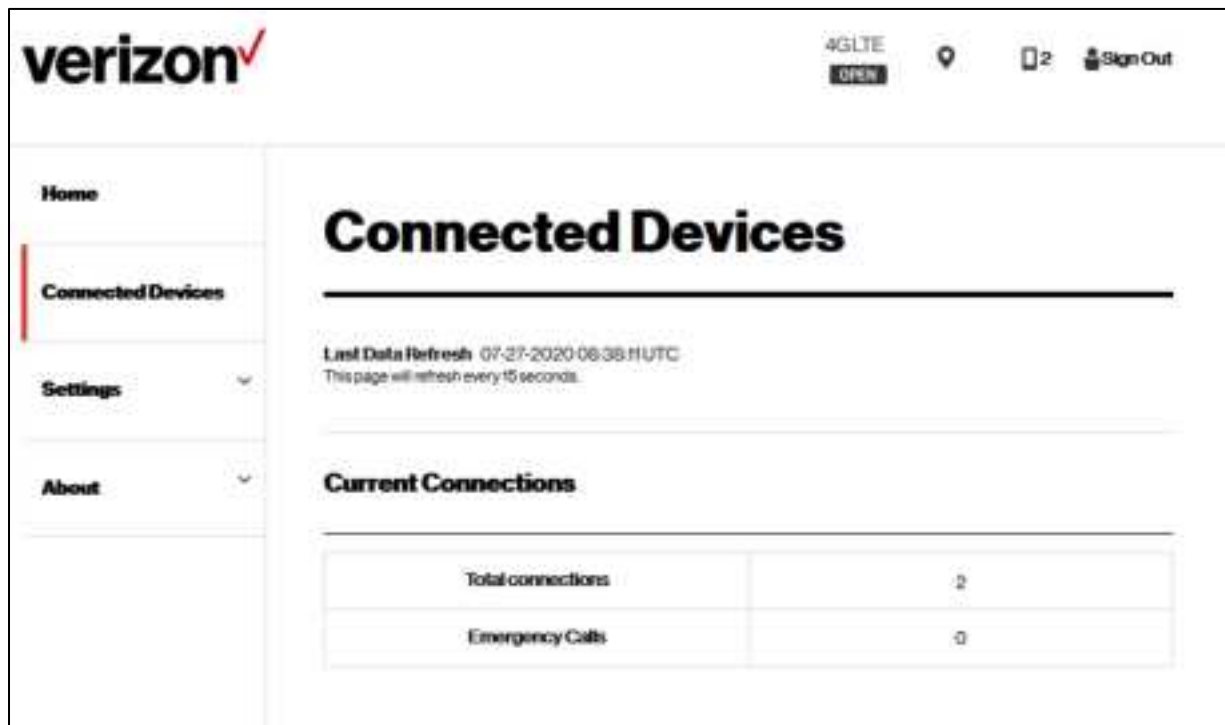

**Current Connections**

Total Connections	Number of total wireless devices currently connected to the LTE Network Extender with an active call or data session.
Emergency Calls	Number of wireless devices currently connected to the LTE Network Extender with an active E911 call to emergency services.

### 3.5 Settings

#### 3.5.1 Network

The Network page displays information about IPv4 and IPv6 settings. You can enable or disable DHCP Server for your Network Extender to be dynamically allocated IP address settings, or manually set IP address and DNS values (when DHCP is disabled). Backhaul limit (affects uplink speeds served by the LTE Network Extender only) and MTU size can also be set here.

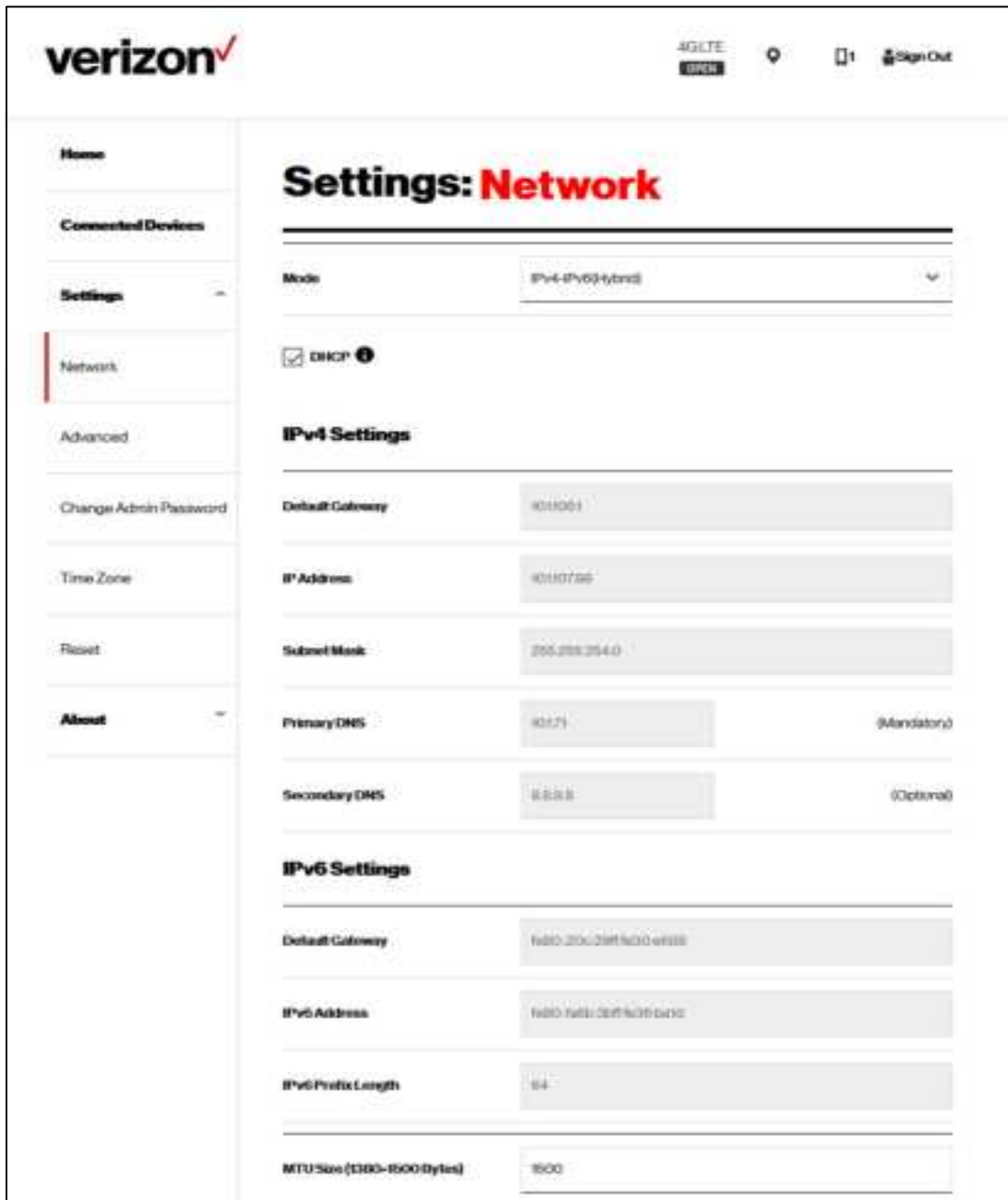

### Mode

Mode	IPv4 or IPv6 mode.
DHCP	DHCP is enabled by default. When enabled, IP configuration is provided by the local DHCP server. When disabled, specify a static IP configuration for the Network Extender manually.

### IPv4 / IPv6

Default Gateway	Displays default gateway IP address. When DHCP is disabled, enter the default gateway IP address here.
IP Address	Displays local IPv4/IPv6 IP address of the Network Extender. When DHCP is disabled, enter the IPv4/IPv6 address here.
Subnet Mask	Displays subnet mask of the Network Extender. When DHCP is disabled, specify a subnet mask here.
Primary DNS	Displays the primary DNS server IP address. When DHCP is disabled, enter the primary DNS server IP address here.
Secondary DNS	Displays the secondary DNS server IP address. When DHCP is disabled, enter the secondary DNS server IP address here.
IPv6	Each item of IPv6 setting is just for the Link-local address
MTU Size	Maximum Transport Unit (MTU) defines the maximum packet size for data transmission over the network. The default setting is recommended. When set too high, users may experience poor voice quality and increased latency. If set too low, overall bandwidth consumption will be increased and users may experience lower data speeds.

### 3.5.2 Advanced

Advanced Settings enables you to configure the LTE Network Extender’s output power and view neighboring cell towers detected during initialization and startup. Provides information on Network Extender positioning relative to other Verizon cell sites and LTE Network Extenders in the network, in the case of multiple Network Extender clusters.

**Settings: Advanced**

Last Data Refresh: 09-15-2020 07:21:03 UTC

**4GLTE Network Extender Information**

Network ID - CELL ID	DEC: 40543-244 HEX: B025-F4
Physical CELL ID (PCI)	500
LTE EMBFCN	0250

Automatic Transmit Power Mode

**Transmit Power 10 - 100%**

Slider: 10 dBm (10 mW) to 20 dBm (100 mW). Current setting: 80% (18.0 dBm / 63.1 mW). Recommended: 17.0 dBm (50 mW).

**Neighboring Cells Detected**

as of 09-15-2020 07:21:03 UTC [update](#)

Network ID	EMBFCN	Cell ID	PCI	Cell Type	RSRP (dBm)	
31400	2900	83248	97	Macro	-	HeNB Cell
0001	0250	248	481	Extender	-79	OK ✓
0001	3050	248	483	Extender	-79	OK ✓

Buttons: Cancel, Save

Last Data Refresh	Local time when the page was last refreshed.
4G LTE Network Extender Information	Displays the Network Extender's cell network identifier information: Network ID, CELL ID, Physical CELL ID (PCI) and LTE EARFCN. Network ID (PLMN) and Cell ID (ECGI) are linked by a hyphen.
Transmit Power	The transmit power of the Network Extender can be adjusted using the slider according to requirements, from maximum (100% = 100mW = 20dBm) to minimum (10% = 10mW = 10dBm). Digital attenuation in 1mW steps from 10mW to 100mW is used to achieve this.
Neighboring Cells Detected	<p>Displays OTAR results. Can assist a multi-4G LTE Network Extender cluster with positioning and power selection.</p> <ul style="list-style-type: none"> <li>• Network ID: PLMN of the detected cell.</li> <li>• EARFCN: This is the EARFCN of the detected cell.</li> <li>• Cell ID: ECGI of the detected cell.</li> <li>• PCI: PCI of the detected cell.</li> <li>• Cell Type: Displays the result based on OTAR scan if the Cell Tower ID is within range reserved for the 4G LTE Network Extender(s). Otherwise, displays "Macro".</li> <li>• RSRP: Displays the measured RSRP in dBm of the detected cell. An icon is provided alongside the RSRP value indicating if the detected cell is too-close (high RSRP) and may be causing interference; or if it is too far (low RSRP) and handover may be an issue. Note – the distance between two 4G LTE Network Extenders using the same band should be at least 170% of the distance of its coverage radius to avoid LTE interference. In other words, if an LTE Network Extender has a 100 ft. coverage radius in a given environment, the next closest LTE Network Extender using the same band should be at least 170ft away. If two LTE Network Extenders are using different bands from each other, they can be placed side-by-side. Besides, if the neighboring cell reported from UE will be denoted by 'ANR Cell' and provisioned from HeMS will be denoted by "HeMS Cell". These two kinds neighboring cell will not display the RSRP value.</li> </ul>

### 3.5.3 Change Admin Password

You can change the admin password used to sign-in to the Web Admin UI on the Change Admin Password page. When you change password you can set up a security challenge and answer.

In the event of a forgotten password, you can use the Forgot Password prompt at the sign-in page to trigger your security challenge (refer to Section 3.2 - Sign In). You can also reset the password back to the default password by resetting the Network Extender back to its factory default state (refer to Section 1.3 - Reset Button).

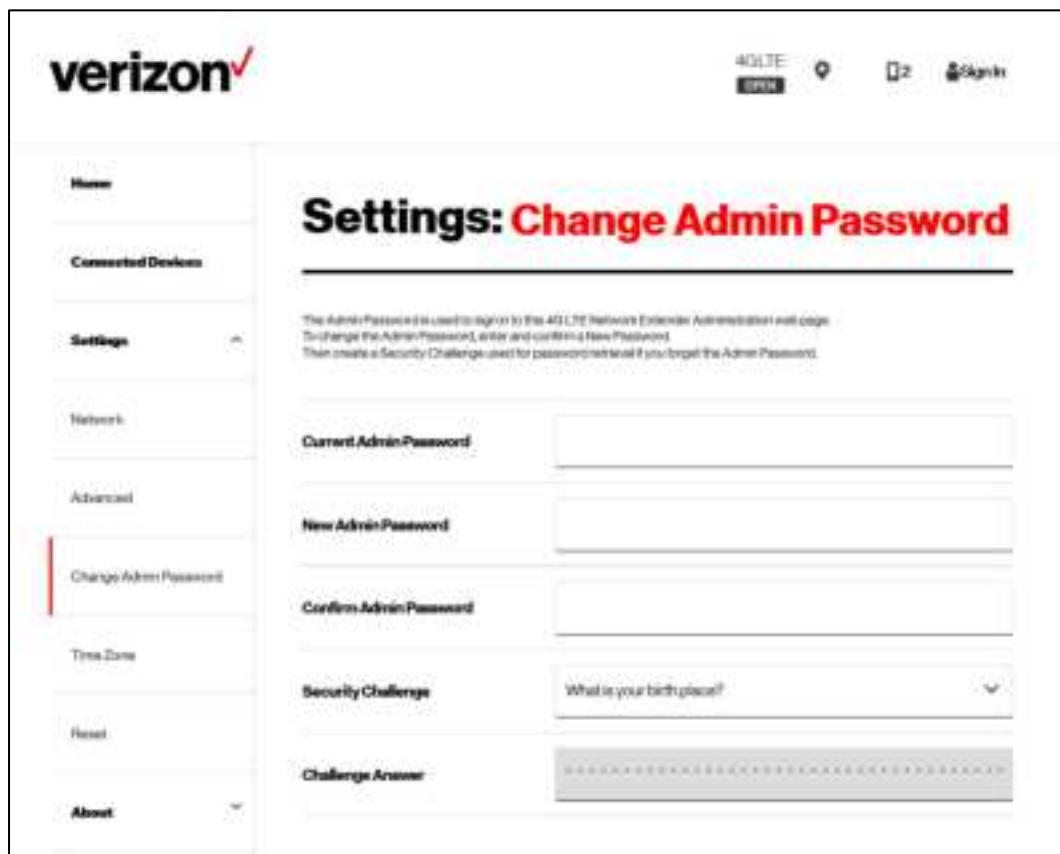

Current Admin Password

Enter the current password. This is required for any password change.

New Admin Password

Enter a new password. Choose hard-to-guess passwords, which include combinations of numbers, letters and symbols. New passwords must meet validation criteria that are detailed below.

Confirm New Password

Enter the new password again for confirmation.

Security Challenge

You can select a question from the drop-down menu as a security challenge in the event of a lost or forgotten password. Be sure to choose something memorable.

Challenge Answer | Enter the correct response to your chosen security challenge question. Be sure to enter something memorable.

#### Password Validation Criteria

- Password must be between 8 and 20 characters long.
- Password must not include more than three identical characters in a row, e.g., “111”, “aaa”, “CCC”.
- Password must include at least one lowercase letter, one uppercase letter and one number.
- New password cannot be the same as current password.

#### Security Challenge Questions

- What is your birthplace?
- What was your first car?
- What is your mother’s maiden name?
- What is your pet’s name?

#### Security Challenge Answer Criteria

- A security answer must be between 1 and 63 characters.

### 3.5.4 Time Zone

The Network Extender features built-in time zone and daylight savings settings to configure for your device. Time zone settings only affect timestamps and logs where featured throughout the Web Admin UI.

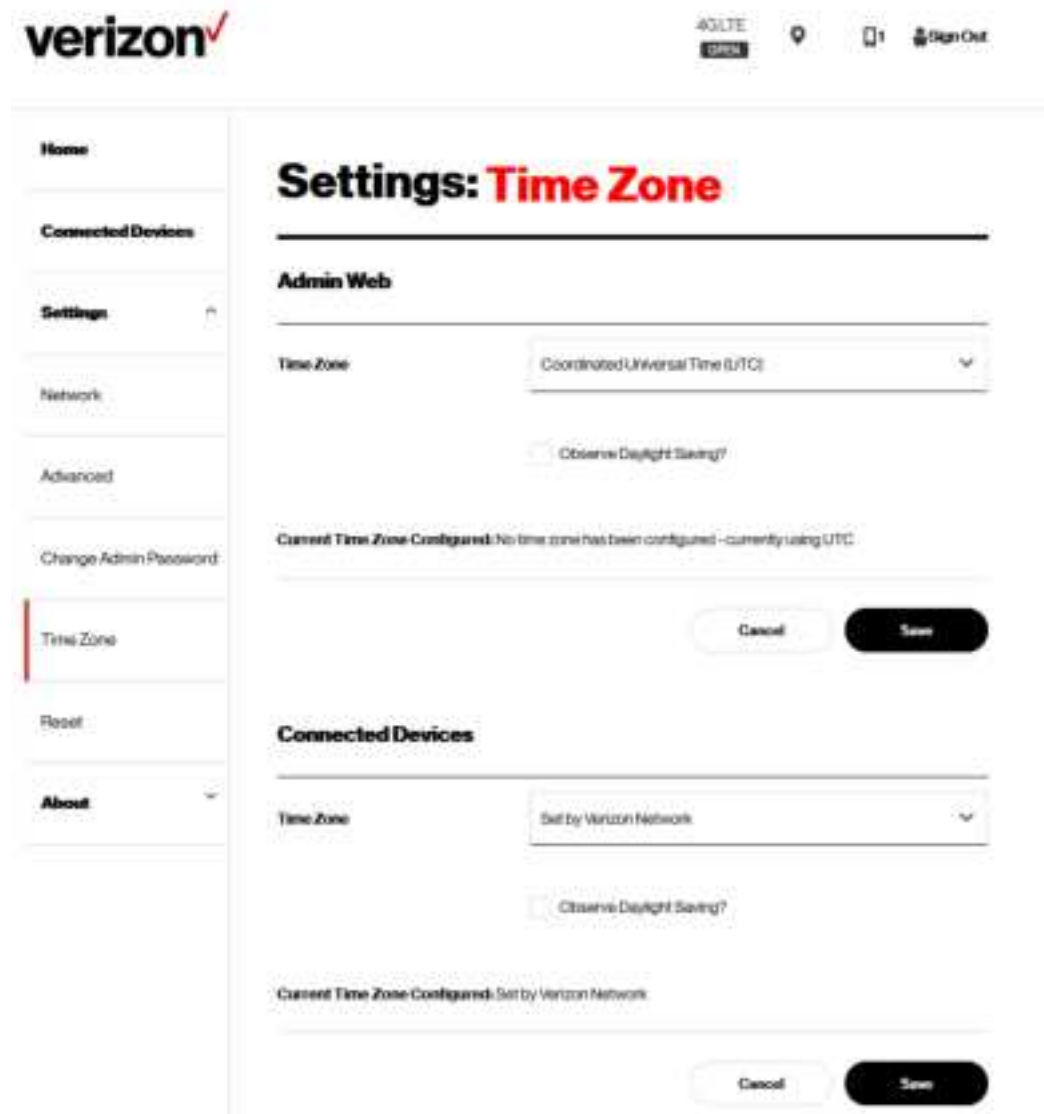

#### Admin Web

- Time Zone
- Observe Daylight Saving?

Select your time zone (or closest) from the options in the drop-down menu.

Select whether to observe daylight savings or not for the selected time zone, using the check box. Daylight saving is not supported for Atlantic (AT), Samoa (ST) & Chamorro (ChT) time.

### 3.5.5 Reset

If the LTE Network Extender malfunctions or is not responding, it is recommended to restart the device or perform a factory reset. Using the Reset page interface you can perform a Complete Restart, Quick Restart or Factory Reset. Be aware that a factory reset will reset all settings and configurations back to factory default settings.

Complete Restart, Quick Restart and Factory Reset are rejected during active E911 calls on the Network Extender.

You can also perform a factory reset using the physical reset button on the back of the Network Extender. Refer to Section 1.3 (Reset Button) for more information.

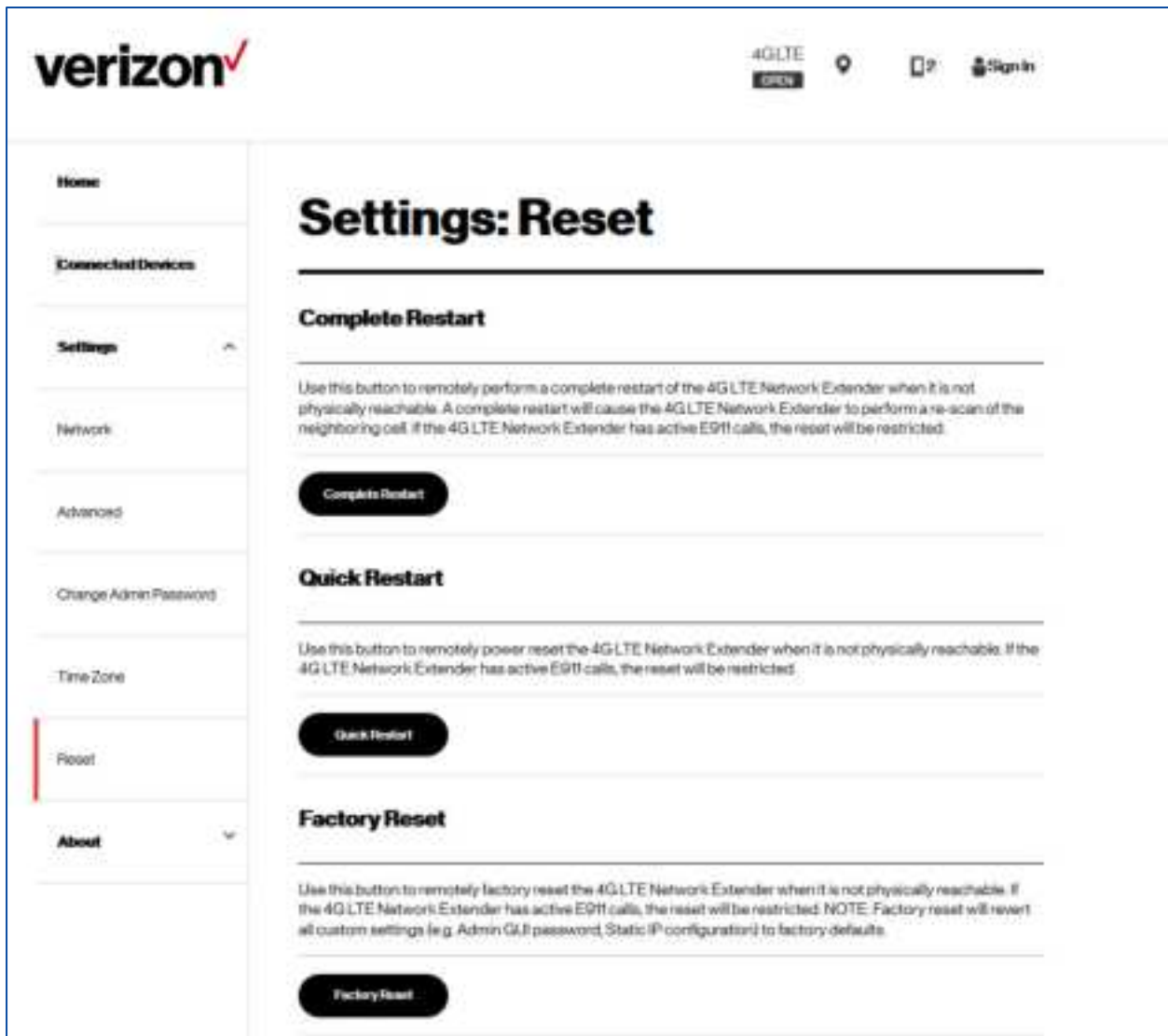

**Complete Restart**

Use this button to remotely perform a complete restart of the LTE Network Extender when it is not physically reachable. A complete restart will cause the LTE Network Extender to perform a re-scan of the neighboring cell. If the LTE Network Extender has active E911 calls, the reset will be rejected.

**Quick Restart** | Use this button to remotely power reset the LTE Network Extender when it is not physically reachable. If the LTE Network Extender has active E911 calls, the reset will be rejected.

**Factory Reset** | Use this button to remotely factory reset the LTE Network Extender when it is not physically reachable. If the LTE Network Extender has active E911 calls, the reset will be rejected. NOTE: Factory reset will revert all custom settings (e.g. Admin GUI password, Static IP configuration) to factory defaults.

### 3.6 About

#### 3.6.1 Status & Alarms

The Status & Alarms tab on the About page shows the connectivity status, operational status and alerts that can be used for diagnostics and troubleshooting. If the connectivity status shows a server as “Not Reachable”, confirm that the Network Extender is properly connected to the router and has acquired an IP Address. For LAN/Routers with a firewall enabled, please see **Chapter 4 (Configuring Your Firewall)**.



<b>Active Alarms</b>			
No	Alarm	Description	Date & Time
1	<a href="#">SYS IPSEC_DOWN</a>	The 4G LTE Network Extender has lost connectivity with the IPsec Server and is not in service.	06-11-2020 01:47:49 UTC

<b>Alarm History</b>			
No	Alarm	Description	Date & Time
1	<a href="#">SYS IPSEC_DOWN</a>	The 4G LTE Network Extender has lost connectivity with the IPsec Server and is not in service.	04-26-2020 17:44:43 UTC
2	<a href="#">SYS IPSEC_DOWN</a>	The 4G LTE Network Extender has lost connectivity with the IPsec Server and is not in service.	04-26-2020 09:41:35 UTC

Last Data Refresh | Local time when the page was last refreshed.

Active Alarms | Displays any active alarms on the LTE Network Extender. Alarms may prevent your Network Extender from coming into service. Please refer to the Description column in the table for more information and reference **5.1 (LCD Display Messages and Error Codes)** for more help.

Alarm History | Displays a log of the LTE Network Extender’s last 100 alarms, including active or cleared alarms.

### 3.6.2 GPS

The GPS page displays GPS status information and includes GPS Satellite IDs, signal quality and signal strength descriptions. This screen can assist with effective placement of your LTE Network Extender to acquire the better GPS signals.

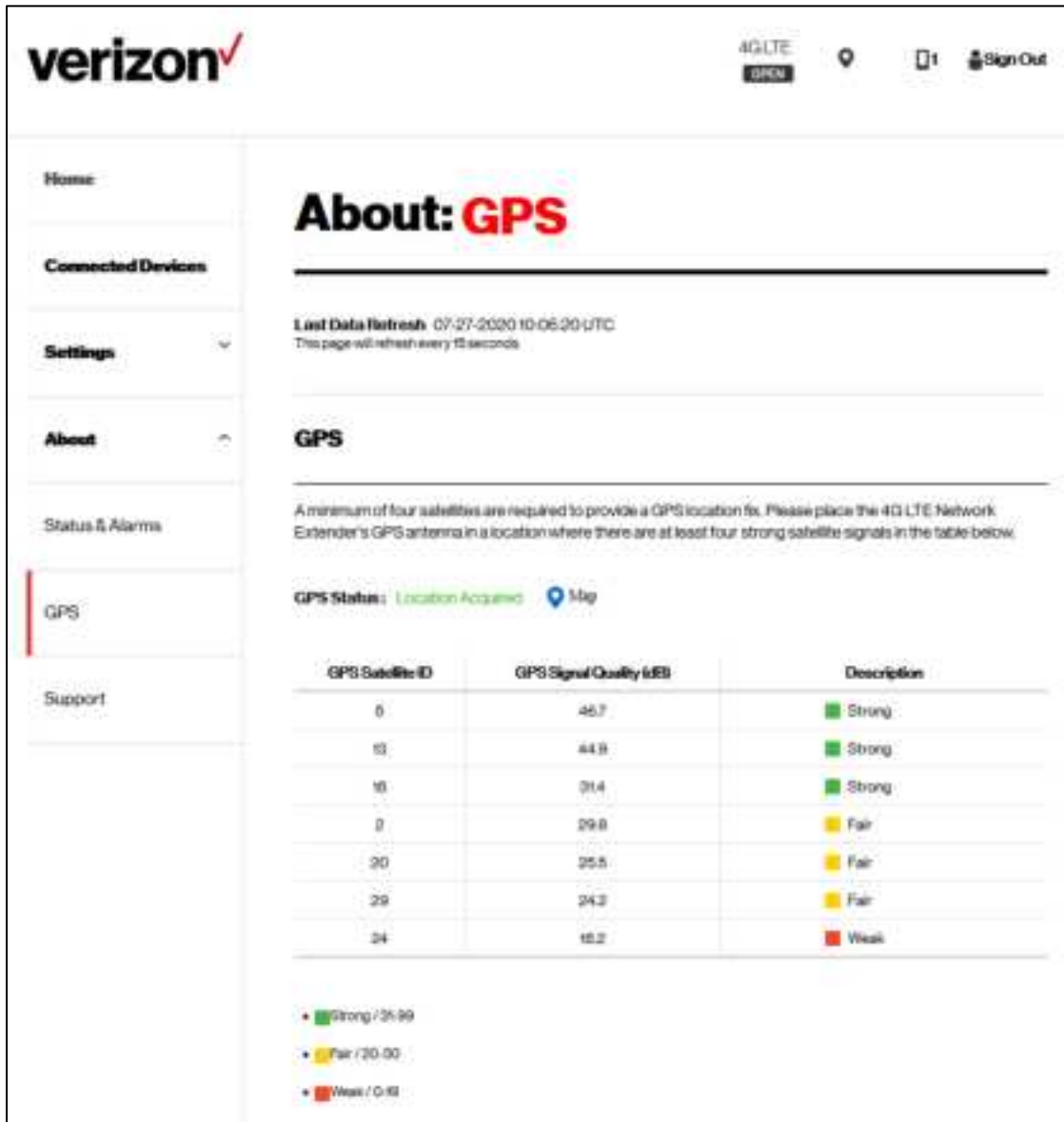

Last Data Refresh | Local time when the page was last refreshed.

#### GPS

GPS Status | Displays GPS signal status, i.e., whether the LTE Network Extender has acquired GPS signals or not. If "Location Acquired" is not displayed, the LTE Network Extender will not come into service.

GPS Satellite ID	Lists GPS satellites which are currently being detected, including each satellite's unique identifier ID.
GPS Signal Quality (dB)	Displays the signal-to-noise ratio in dB for each GPS signal, where a higher value means better quality.
Description	Describes each signal as Strong, Fair or Weak according the Signal Quality level. Strong signal is required for your Network Extender. Consider repositioning your LTE Network Extender if these descriptions are Fair or Weak, or using the internal GPS antenna (refer to Section 2.2 - GPS).

### 3.6.3 Support

The Support page displays contact details and links to relevant information for a range of customer support enquiries.

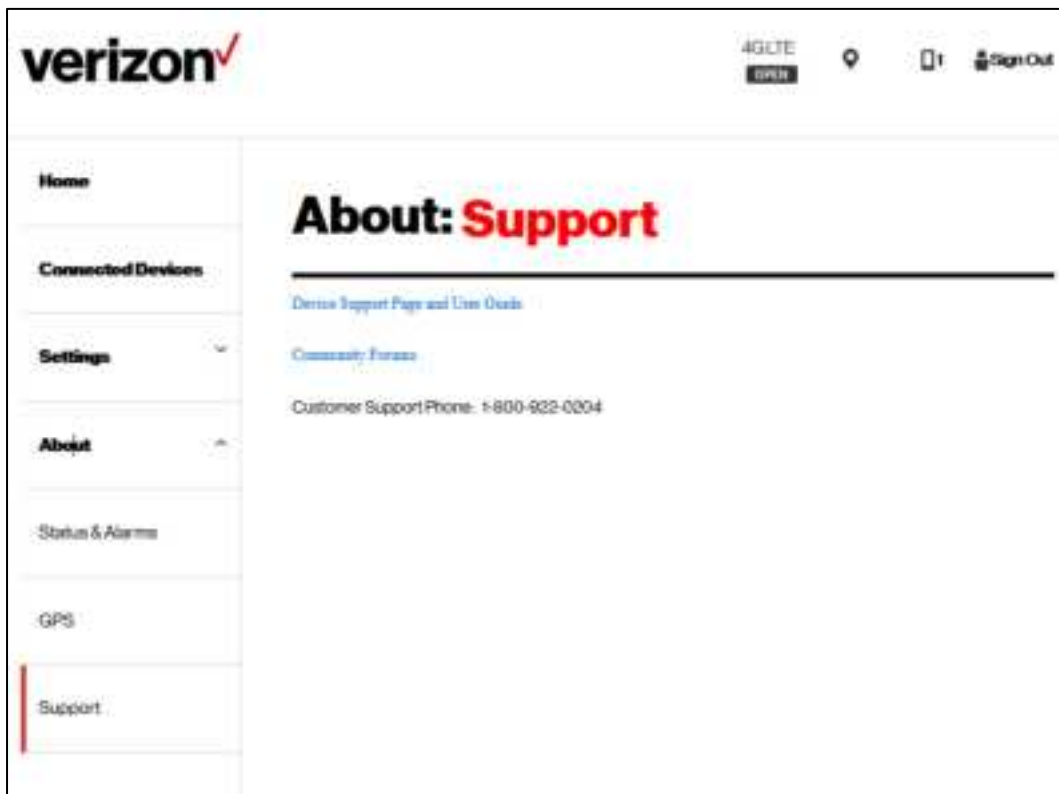

Device Support Page and User Guide	Hyperlink to the operator's support pages.
Community Forums	Hyperlink to the operator's community forums.
Customer Support Phone	Phone number for the operator's customer support.

## 4 Configuring Your Firewall

---

In most cases, the LTE Network Extender can connect and automatically configure network settings, with minimal user involvement. In cases where local firewall settings may need to be configured, refer to the information below:

### Firewall Settings

Source	Destination	Protocol	Destination Port	Notes
LTE Network Extender	GPS Assistance Server	TCP	80	
LTE Network Extender	DNS Server	UDP/TCP	53	
LTE Network Extender	NTP Server	UDP/TCP	123	
LTE Network Extender	VzW SeGW	UDP	500/4500	More than one port may be used for multiple device installation
LTE Network Extender	VzW SeGW	ESP/50	NA	When NAT/PAT is not present
LTE Network Extender	LTE Network Extender	ESP/50	NA	When NAT/PAT is not present

## 5 Troubleshooting

---

### The Power LED is off.

- Check that the power adapter is properly inserted into the 12V DC Power Port on the back of the LTE Network Extender, and that it is securely connected to a working power outlet.

### The LTE Network Extender has not acquired a GPS signal after one hour or more.

- Try to position your LTE Network Extender in a new location. An ideal location is as close to a window as possible, in an open area with few surrounding obstructions. Elevating the Network Extender on a cabinet or shelf may also help.
- Ensure that other devices are not interfering with your Network Extender: your LTE Network Extender should be at least 10 feet away from any communications device or appliance that generates electromagnetic radiation such as microwave ovens or Wi-Fi routers.
- Take out the internal GPS antenna as described in Section 2.2 (GPS) and place it close to a window.
- If using another/other LTE Network Extender(s), ensure that their GPS antennas are at least 150 mm apart.
- Ensure that the GPS antenna is connected properly. The GPS antenna must always be connected to the LTE Network Extender for operation.
- If you cannot reposition the Network Extender or the internal GPS antenna and acquire a signal, you may need to separately purchase and install an external outdoor antenna.

### Unable to make a call using the LTE Network Extender.

- Make sure the Network Extender is powered on and operational.
- Ensure that your router is working properly and has an active Internet connection. Usually the Internet activity LED on your router should display some activity to indicate this. Refer to the support documentation of your router for more information.
- Make sure you are within coverage range of your LTE Network Extender (see Section 5.1 - Capacity & Coverage).
- Check that Advanced Calling is turned on for your Verizon phone as shown in Section 2.4 (Making a Call).
- Verify that your Verizon phone is connected to the LTE Network Extender by dialing #48.

### LTE Network Extender Activation

Confirm that your LTE Network Extender was activated at the time of purchase. If not, call Verizon Wireless Customer Service at (800) 922-0204 or call \*611 from your Verizon Wireless mobile phone and select the option for technical support. Before contacting Verizon Wireless Customer Service, please confirm:

- Your router is working properly and has an active Internet connection. Usually the Internet activity LED on your router should display some activity to indicate this. Refer to the support documentation of your router for more information.
- Your LTE Network Extender is receiving a GPS signal. You can check this by using the Display Button to view GPS information on the LCD screen (see 2.1.1 - LCD Display), and on the GPS page of the Web Admin UI (see 3.6.2. - GPS).

### 5.1 Capacity & Network Coverage

Your LTE Network Extender has the following capacity and coverage:

- Capacity: Up to fourteen simultaneous active users + one channel reserved for E911 calls + one channel reserved for redirect.
- Coverage: Approximately 7500 square feet (50-foot radius).

Coverage may vary based on environmental factors, floor plan and RF absorption of building materials.

### 5.2 LCD Display Messages & Error Codes

The following messages or error codes may appear on the display of the LTE Network Extender during operation or startup process:









Error Code	Category	LCD Display	Content	Description
	Startup			Booting up.
	Startup		Factory reset restarting Please wait...	Factory reset: shutting down.
	Startup			Factory reset: starting up.
	Startup		Hardware initializing Please wait...	Hardware initializing.
<b>2A</b>	Startup		Hardware Error 2A Please check user guide	The LTE Network Extender has a Hardware Error disrupting its normal booting-up process; please try restarting the device. If the error persists, please call Customer Service (800-922-0204).

2B	Startup		Hardware Error 2B Please check user guide	The LTE Network Extender has a malfunctioning RF antenna, and the device can no longer provide proper service. Please call Customer Service (800-922-0204).
	Startup		Software initializing Please wait...	Software initializing.
3A	Startup		Software Error 3A Please check user guide	The LTE Network Extender has a Software Error disrupting its normal booting-up process; please try restarting the LTE Network Extender. If the error persists, please call Customer Service (800-922-0204).
	Startup		Connecting to Router Please wait...	Acquiring local IP address.
4A	Startup		Connection Error 4A Check Ethernet cable	The Ethernet port on the LTE Network Extender is not operational; please check the Ethernet cable is properly connected at both ends, and the switch, router or Internet gateway is turned on.
	Startup		Connecting to CMP server Please wait...	Getting certificate from CMP server.
5A	Startup		Server Error 5A Please check user guide	The LTE Network Extender has failed to get certificate from the CMP server; please contact your network administrator. If the issue persists, please call Customer Service (800-922-0204).
	Startup		Searching GPS signal Please wait... up to 10mins	GPS acquisition.
6A	Startup		GPS Insufficient Error 6A Please check user guide	The LTE Network Extender has failed to acquire minimally required GPS signal; please try to move your GPS antenna closer to the window, refer to Sections <b>2.1 Setup: Network Extender</b> , <b>2.2 Setup: GPS &amp; 5 Troubleshooting</b> . If the issue persists, please call Customer Service (800-922-0204).

<b>6B</b>	Startup		GPS antenna Error 6B Please check GPS antenna connection	No GPS antenna is detected in the LTE Network Extender, please make sure a GPS antenna module is set up and connected to the device. If the issue persists, please call Customer Service (800-922-0204).
<b>6C</b>	Startup		GPS clock Error 6C Please check user guide	The LTE Network Extender failed to receive a clock signal from its GPS module; please try to move your GPS antenna closer to the window, refer to Sections <b>2.1 Setup: Network Extender</b> , <b>2.2 Setup: GPS &amp; 5 Troubleshooting</b> . If the issue persists, please call Customer Service (800-922-0204).
	Startup		Connecting to SeGW server Please wait...	SeGW discovery and IPsec setup (init/serv).
<b>7A</b>	Startup		Server Error 7A Please check user guide	The LTE Network Extender failed to establish IPsec tunnel to connect to SeGW; please check the LAN/firewall settings (refer to <b>4 - Configuring Your Firewall</b> ) or contact your network administrator. If the issue persists, please call Customer Service (800-922-0204).
	Startup		Connecting to HeMS server Please wait...	HeMS discovery and download of configuration file.
<b>8A</b>	Startup		Server Error 8A Please check user guide	The LTE Network Extender received incorrect provisioning parameters from HeMS, for example, incorrect bandwidth, wrong command sequence in setting EARFCN for ANR or unsupported band. If the issues persists, please call Customer Service (800-922-0204).
<b>8B</b>	Startup		Out of service area Error 8B Please check user guide	The LTE Network Extender is out of Verizon's service area; it could be that Verizon service is not available in your area. Please try to restart your device, if the issue persists, please call Customer Service (800-922-0204).
<b>8C</b>	Startup		Server Error 8C Please check user guide	The LTE Network Extender received a "403 Forbidden" error message from the management server. Please try to restart your device. If the issue persists, please call Customer Service (800-922-0204).
<b>8D</b>	Startup		Server Error 8D Please check user guide	The LTE Network Extender received a "500 Internal Server Error" from the management server. Please try to restart your device. If the issue persists, please call Customer Service (800-922-0204).

<b>8E</b>	Startup		<p>Server Error 8E Please check user guide</p>	<p>The LTE Network Extender is put into maintenance mode (Admin=0) by the management server, and no UE can register on the device. If the issue persists, please call Customer Service (800-922-0204).</p>
	Startup		<p>Connecting to HeGW server Please wait...</p>	<p>Serving HeGW discovery.</p>
<b>9A</b>	Startup		<p>Server Error 9A Please check user guide</p>	<p>The LTE Network Extender failed to connect to the HeNB Gateway; please check the LAN/firewall settings or contact your network administrator. If the issue persists, please call Customer Service (800-922-0204).</p>
<b>9B</b>	Startup		<p>Server Error 9B Please check user guide</p>	<p>The LTE Network Extender failed to communicate with Verizon's backend network; please check the LAN/firewall settings or contact your network administrator. If the issue persists, please call Customer Service (800-922-0204).</p>
<b>9C</b>	Startup		<p>Server Error 9C Please check user guide</p>	<p>The LTE Network Extender detected a PCI collision problem with the PCI setting assigned by the management server. Please try restarting your device. If the issue persists, please call Customer Service (800-922-0204).</p>
	Info		<p>Service Active... Press the button to view device information.</p>	
	Info		<p>9/11 Satellites connected 0/14 Devices connected</p>	<p>Displays GPS satellite connections &amp; connected devices.</p>
	Info		<p>Service: Active, Open IP address: 10.1.107.26 Mac address: F8:5B:3B:36:BA:2C</p>	<p>Displays LTE Network Extender information.</p>
	Info		<p>Device serial number: SC0201900025</p>	<p>Displays LTE Network Extender information.</p>

20	System		<p>No service Error 20 The device is overheating Please check user guide</p>	<p>The LTE Network Extender is overheating; please place this device in a cool area where the temperature is between 32-122 degrees Fahrenheit.</p>
21	System		<p>No service Error 21 Please check user guide</p>	<p>The LTE Network Extender is experiencing a catastrophic hardware failure with the antenna. Please call Customer Service (800-922-0204).</p>
22	System		<p>No service Error 22 Please check user guide</p>	<p>There is an abnormally low transmission signal from your LTE Network Extender affecting the functionality of the device. The device will try to reboot itself in a moment; please don't unplug your Network Extender. If the issue continues after auto-reboot, please call Customer Service (800-922-0204).</p>
23	Ethernet		<p>No service Error 23 Please check user guide</p>	<p>The Ethernet port on the LTE Network Extender is not operational; please check the Ethernet cable is properly connected at both ends, and that the switch, router or internet gateway is turned on.</p>
24	GPS		<p>GPS antenna Error 24 Please check user guide</p>	<p>No GPS antenna is detected in the LTE Network Extender; please make sure a GPS antenna module is set up and connected to the device. If the issue persists, please call Customer Service (800-922-0204).</p>
25	GPS		<p>GPS antenna Error 25 Please check user guide</p>	<p>The LTE Network Extender has not been able to acquire a GPS signal for the past 24 hours. As a result, the device can no longer provide service. Please try to move your GPS antenna closer to the window. If the issue continues, you may need to acquire an outdoor GPS antenna.</p>
26	GPS		<p>GPS signal Error 26 Please check user guide</p>	<p>The LTE Network Extender has failed to acquire the minimally required GPS signal; please try to move your GPS antenna closer to the window, refer to Sections <b>2.1 Setup: Network Extender</b>, <b>2.2 Setup: GPS &amp; 5 Troubleshooting</b>. If the issue persists, please call Customer Service (800-922-0204).</p>
27	Service		<p>No service Error 27 Please check user guide</p>	<p>The LTE Network Extender failed to establish IPSec tunnel to connect to SeGW, and the device can no longer provide service to your mobile devices. Please check the LAN/firewall settings or contact your network administrator. If the issue persists, please call Customer Service (800-922-0204).</p>
28	Service		<p>Out of service area Error 28 Please check user guide</p>	<p>The LTE Network Extender is out of Verizon's service area; it could be that Verizon service is not available in your area. Please try restarting your device again. If the issue persists, please call Customer Service (800-922-0204).</p>

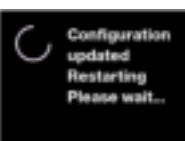
29	Service		No service Error 29 Please check user guide	The LTE Network Extender received a "403 Forbidden" error message from the management server. Please try restarting your device. If the issue persists, please call Customer Service (800-922-0204).
30	Service		No service Error 30 Please check user guide	The LTE Network Extender received a "500 Internal Server Error" from the management server. Please try restarting your device. If the issue persists, please call Customer Service (800-922-0204).
31	Service		No service Error 31 Please check user guide	The LTE Network Extender is put into maintenance mode (Admin=0) by the management server, and no UE can register on the device. If the issue persists, please call Customer Service (800-922-0204).
32	Service		No service Error 32 Please check user guide	The LTE Network Extender failed to connect to the HeNB Gateway, please check the LAN/ firewall settings or contact your network administrator. If the issue persists, please call Customer Service (800-922-0204).
33	Service		No service Error 33 Please check user guide	The LTE Network Extender detected a PCI collision problem with the PCI setting assigned by the management server. Please try restarting your device. If the issue persists, please call Customer Service (800-922-0204).
34	Service		No service Error 34 Please check user guide	The LTE Network Extender has a communication failure with Verizon's network, preventing your device from providing service to mobile devices. Please try restarting your Network Extender. If the issue persists, please call Customer Service (800-922-0204).
35	System		System msg Error 35 Please wait We will retry shortly	The LTE Network Extender experienced failure while upgrading its software. The device will try to reboot itself in a moment; please don't unplug your device. If the issue continues after auto-reboot, please call Customer Service (800-922-0204).
	System		Updating software please wait...	Upgrading software.
	System		Configuration updated. Restarting Please wait...	System restarting after a configuration update, e.g., changed band.

System	 A black rectangular screen with a white crescent moon icon in the top left corner. The text "Restarting" is centered at the top, and "Please wait..." is centered below it.	Restarting Please wait...	System restarting.
--------	---	------------------------------	--------------------