



# MAGNE-BLAST CIRCUIT BREAKER

## TYPES

- AM-4.16-250-6C
- AM-4.16-250-6H
- AM-4.16-250-7C
- AM-4.16-250-7H

## CONTENTS

Introduction .....	1
Receiving, Handling and Storage .....	1
Installation .....	2
Description of Operation .....	4
Adjustments .....	6
General Maintenance .....	12
Renewal Parts .....	28

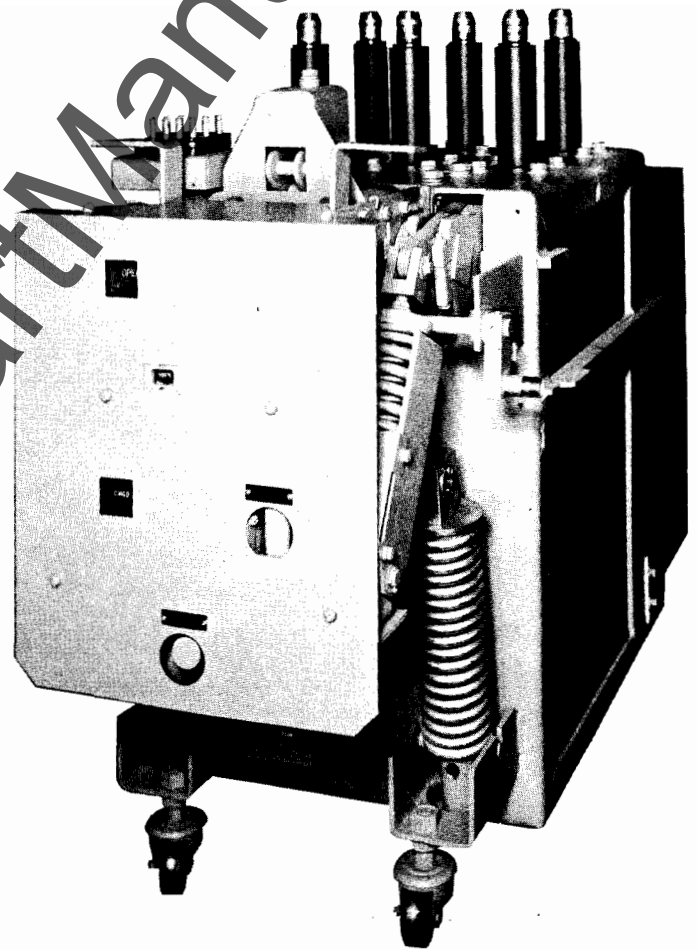

SWITCHGEAR DEPARTMENT

GENERAL  ELECTRIC

PHILADELPHIA, PA.

MAGNE-BLAST CIRCUIT BREAKER

AM-4.16-250-6 (Δ)  
 AM-4.16-250-7 (Δ)

Δ Letter Designation -B,C, and H, used immediately following the model number indicates basic design features.

INTRODUCTION

The magne-blast circuit breaker is the removable interrupting element for use in vertical-lift metal-clad switchgear, to provide reliable control and protection of power systems. Among the many advantages of metal-clad switchgear are added protection to equipment and personnel, compactness, simplified installation and reduced maintenance. In keeping with these features the magne-blast breakers are designed for interchangeability and maneuverability, together with reliability and low maintenance requirements.

The magne-blast circuit breaker operates on the principle that an arc can be interrupted in air by sufficiently elongating and cooling it. This is accomplished by means of a strong magnetic field that lengthens the arc and forces it into intimate contact with cool dielectric material. A sturdy, reliable operating mechanism assures low maintenance and long life.

The AM-4.16 magne-blast breaker is available in a number of current ratings. Refer to the breaker nameplate for the complete rating information of any particular breaker. The short circuit conditions to be imposed on the breaker must not exceed its rating, nor should it be called upon to operate at voltages or currents greater than those given on the nameplate. Since this book is written to cover several ratings of breakers that are of the same general design, all instructions will be of a general character and all illustrations will be typical, unless otherwise specified.

PROPER INSTALLATION AND MAINTENANCE ARE NECESSARY TO INSURE CONTINUED SATISFACTORY OPERATION OF THE BREAKER. The following instructions will provide complete information for placing the magne-blast breaker in service and for maintaining satisfactory operation.

RECEIVING, HANDLING AND STORAGEReceiving and Handling

Each breaker is carefully inspected and packed by workmen experienced in the proper handling and packing of electrical equipment. Immediately upon receipt of the circuit breaker, an examination should be

These instructions do not purport to cover all details or variations in equipment nor to provide for every possible contingency to be met in connection with installation, operation or maintenance. Should further information be desired or should particular problems arise which are not covered sufficiently for the purchaser's purposes, the matter should be referred to the General Electric Company.

made for any damage sustained in transit. If injury or rough handling is evident, a damage claim should be filed immediately with the transportation company and the nearest General Electric Sales Office should be notified.

It is expected that due care will be exercised during the unpacking and installation of the breaker so that no damage will occur from careless or rough handling, or from exposure to moisture or dirt. Loose parts associated with the breaker are always included in the same crate. Check all parts against the packing list to be sure that no parts have been overlooked.

### Storage

It is recommended that the breaker be put into service immediately in its permanent location. If this is not possible, the following precautions must be taken to insure the proper storage of the breaker:

1. The breaker should be carefully protected against condensation, preferably by storing it in a warm dry room, since water absorption has an adverse effect on the insulation parts. Circuit breakers for outdoor metal-clad switchgear should be stored in the equipment only when power is available and the heaters are in operation to prevent condensation.
2. The breaker should be stored in a clean location, free from corrosive gases or fumes; particular care should be taken to protect the equipment from moisture and cement dust, as this combination has a very corrosive effect on many parts.
3. Machined parts of the operating mechanism, etc., should be coated with a heavy oil or grease to prevent rusting.

If the breaker is stored for any length of time, it should be inspected periodically to see that rusting has not started and to insure good mechanical condition. Should the breaker be stored under unfavorable atmospheric conditions, steps should be taken to dry out the breaker before it is placed in service.

### INSTALLATION

1. Remove the box barrier and front cover and make a visual inspection to ascertain that the breaker and mechanism is in satisfactory condition. Check all bearing surfaces of the mechanism for lubrication. Refer to section on Lubrication (page 14)
2. Charge the breaker closing springs manually using a 5/8" ratchet wrench to turn the driving eccentric (6) Fig. (4). Turning the eccentric counter clockwise will advance the ratchet wheel and compress the springs.

When the springs have reached the fully charged position the indicator (10) Fig. (4) will read "CHARGED", and the driving pawl will be raised from the ratchet wheel teeth. Additional turning of the eccentric will not advance the ratchet wheel.

Insert the spring blocking device (4) Fig. (4) and manually discharge the springs against the pins by pushing the manual release button (1) Fig. (4). The springs are now blocked and slow closing of the breaker contacts can be accomplished by again turning the driving eccentric with a 5/8 ratchet wrench.

During the slow closing operation check to insure that the mechanism does not stick or bind during the entire stroke, that it latches securely in the closed position, and that it trips freely when the manual trip lever is operated. The breaker should not be operated electrically until it has been operated several times manually to insure freedom of action. At this time, also check the following adjustments:

- a. Primary contact wipe (Refer to page 7)
- b. Arcing contact wipe (Refer to page 7)
- c. Primary contact gap (Refer to page 7)

"DO NOT WORK ON EITHER THE BREAKER OR MECHANISM UNLESS THE CLOSING SPRINGS ARE BLOCKED AND THE OPENING SPRINGS HAVE BEEN TRIPPED OPEN OR MECHANICALLY BLOCKED. THIS PRECAUTION IS REQUIRED TO PREVENT ACCIDENTAL CLOSING OR TRIPPING."

After the adjustments have been checked, the springs can be unblocked. Rotate the driving eccentric until the indicator reads "CHARGED" and the ratchet wheel no longer is advanced. The blocking device can now be removed.

3. Attach test coupler to circuit breaker and operate electrically several times. Check the control voltage as described under "CONTROL POWER CHECK".

NOTE: If the breaker secondary wiring is to be given a hi-potential test at 1500 volts, remove both the motor leads from the terminal connection. Failure to disconnect the motor from the circuit may cause damage to the winding insulation.

4. Remove the test coupler and replace box barrier.
5. If breaker has been stored for a long period of time, it is recommended that the insulation be checked with a standard 60 cycle high potential test. Refer to Insulation Test (page 13).
6. Lubricate the silver portion of the primary disconnect studs by rubbing a small amount of contact lubricant D50H47 to form a thin coating on the ball contact.
7. Refer to metal-clad instruction book GEH-1802 for final instructions before inserting the breaker into the metal-clad unit.

DESCRIPTION OF OPERATION

The magne-blast breaker is composed of two major parts, the breaker element and the operating mechanism. The breaker element comprises three similar pole units, each pole unit consisting of main and arcing contacts, an interrupter, and an enclosing box barrier that segregates the interrupting units from each other to provide insulation between phases as well as from each phase to ground. The primary connections to the associated metal-clad equipment are made through the primary disconnect studs.

The ML-13 operating mechanism shown in Figures 1, 2, and 3 is of the stored energy type designed to give high speed closing and opening. The mechanism will operate on a-c or d-c voltage as indicated on the breaker name plate. Closing and opening operations are controlled electrically by the metal-clad or remote relaying, and mechanically by the manual close and trip levers on the breaker. All secondary connections from the breaker to the metal-clad unit are made through the coupler (1) Fig. (1).

A positive interlock (2) Fig. (3) and interlock switch (2) Fig. (1) are provided between the breaker and metal-clad unit to prevent raising or lowering of the breaker in the unit while in a closed position and to prevent a closing operation when the breaker is not in either the fully raised or lowered position. A plunger can also be provided to operate an additional auxiliary switch mounted in the metal-clad unit.

When the breaker is interchangeable with MS-13 solenoid operated breakers in M-26 metal-clad units, motor circuit fuses are mounted on the breaker for protection. These breakers are identified by the "C" suffix in the breaker nomenclature.

In case when breakers with ML-13 operating mechanisms must match and line up with breakers having ML-11 mechanisms the spring charging circuit should be fused with Buss Company Fusetrons as follows:

Control Voltage	Fuse Size	Cat. No.
48v - d-c	10A	FRN 10
110v - d-c	4A	FRN 4
125v - d-c	4A	FRN 4
115v - a-c	4A	FRN 4
220v - d-c	2.5A	FRN 2.5
250v - d-c	2.5A	FRN 2.5
230v - a-c	2.5A	FRN 2.5

Spring Charging

The mechanism consists of a high speed gear motor that compresses a set of closing springs through the action of a simple eccentric, ratchet, and pawl assembly. The rotary action of the motor (2) Fig. (4) is converted to a short straight stroke pumping action through the eccentric (6) and a lever that carries a spring loaded driving pawl (5).

The pawl advances the ratchet wheel (3) Fig. (3) only a few degrees each stroke where it is held in position by the latching pawls (1). When the ratchet wheel has been rotated approximately 180 degrees the closing springs (6) will be fully compressed. As the ratchet wheel continues to rotate, the spring load will shift over center and attempt to discharge. After only a few degrees of rotation, the closing roller (10) Fig. (1) will engage the closing latch (11) and the compressed springs will be held in repose until a closing operation is required. During the last few degrees of the ratchet wheel rotation the motor and interlock switches (6) are released and the driving pawl is raised from the ratchet wheel surface. This allows the motor and driving mechanism to coast to a natural stop expending all residual energy.

During the time the springs are being compressed a relay (6) Fig. (6) locks the closing power circuits open and the relay will remain energized until the springs are fully charged and the control contacts are re-set.

The closing springs may be charged manually if control voltage is lost. A 5/8" ratchet wrench can be used to rotate the eccentric in a counter clockwise direction until the indicator reads "CHARGED" and the driving pawl no longer engages the ratchet wheel. The use of the ratchet wrench provides for maximum safety in the event that control power is suddenly restored without warning. In this event, the motor drive will take over again and continues to charge the springs.

#### Closing Operation

Closing the breaker is accomplished by energizing the closing solenoid or by manually pressing the close button. In either case, the closing latch is removed from the spring blocking location allowing the springs to discharge. The energy of the springs is applied to the rotation of a cam (16) Fig. (5) that closes the breaker through a simple linkage that remains trip free at all times. A monitoring switch (11) Fig. (6) on the closing latch will start the spring charging motor after it is fully reset.

#### Opening Operation

An electrical opening operation is initiated by energizing the trip coil. This is accomplished either by actuating the opening control switch on the metal-clad unit or by a combination of relays and current devices used to detect a fault on the load side of the breaker. By energizing the trip coil, the trip plunger rotates the trip latch (7), Fig. (5), causing the operating mechanism linkage to collapse. The energy stored in the opening springs is thus released, opening the breaker. During this operation, the trip coil circuit is deenergized, and upon completion of the opening operation, the operating mechanism is returned to its normal position, ready for closing.

As the breaker opens, the main contacts part first, shunting the current through the arcing contacts. An arc forms as the arcing contacts part. See Fig. (7). As the movable arcing contact (27) is withdrawn through the slot or between the arcing probes on the arc runner, the upper end of the arc is transferred to the upper arc runner (4). To assist the interruption at this point, a stream of air is emitted from the booster tube (28) and forces the arc onto the lower arc runner (10). Establishment of the arc on the runners automatically inserts the blowout coils into the circuit, introducing a magnetic field between the pole pieces which tends to draw the arc away from the arcing contacts. The interrupter contains one upper magnetic blowout coil and one lower blowout coil each individually connected in series with its respective arc runner. The arc is forced outward along the diverging arc runners by the magnetic field.

At the same time, the arc is being forced into the arc chute (8) which is composed of a series of gradually interleaving insulating fins. These fins, which project alternately from the two opposite inner surfaces of the chute, elongate the arc into a gradually deepening serpentine path, so that the electrical resistance in the path of the arc is rapidly increased and the heat from the arc is absorbed. The increased resistance reduces both the magnitude and the phase angle of the current, and at an early current-zero the arc path is so long and the gases produced by the arc so cooled that the arc cannot reestablish itself, and interruption occurs.

Manual tripping follows the same procedure except that instead of energizing the trip circuit, the manual trip (11), Fig. (2) is used.

#### Trip Free Operation

If the trip coil circuit is energized while the breaker is closing, the trip plunger will force the trip latch (8) Fig. (5) away from the trip roller (9) causing the mechanism linkage to collapse and the breaker to re-open. The closing cam (16) will complete its closing stroke and the springs will re-charge as in a normal closing operation.

#### ADJUSTMENTS

All adjustments should be checked during periodic inspections and whenever it becomes necessary to repair or replace parts that have become worn or defective while in service. The following adjustments are listed in the order in which they are to be checked. First, however, remove the breaker from the metal-clad unit and remove the box barriers and front cover.

"DO NOT WORK ON EITHER THE BREAKER OR MECHANISM UNLESS THE CLOSING SPRINGS ARE BLOCKED AND THE OPENING SPRINGS HAVE BEEN TRIPPED OPEN OR MECHANICALLY BLOCKED. THIS MEASURE IS REQUIRED TO PREVENT ACCIDENTAL CLOSING OR TRIPPING."

### Primary Contact Wipe

When the breaker is closed, as shown in Fig. (8), the stationary primary contacts (1) should rise  $5/16" + 0 - 1/16"$ . Before checking this dimension be sure the mechanism is re-set so that the prop pin (13) Fig. (5) is resting on the prop. To obtain the proper contact adjustment, open the breaker and, referring to Fig. (9), loosen the check nut (4) and turn the adjusting nut (3). Screwing up on the adjusting nut will decrease the primary contact wipe, down will increase it. Tighten the check nut, close the breaker and recheck the wipe. With the primary contact wipe correctly adjusted, the clearance between the contact arm (6) and the buffer block should be  $1/16"$  or greater (as shown in Fig. 8) when the breaker is fully closed.

### Arcing Contact Wipe

Refer to Fig. (8). Close the breaker until the arcing contacts just touch. This can be determined with the use of a circuit continuity tester such as a light indicator or bell set. In this position, the gap between the stationary primary contacts (1) and the movable primary contact (2) should be  $5/16"$  or greater. This setting has been made in the factory and no adjustment is provided. A wipe of less than  $5/16"$  is usually an indication that the arcing contacts need to be replaced. When making this check, also see that the movable arcing contact (5) passes between the slots or the arcing probes on the upper arc runner without touching, whichever is applicable.

### Primary Contact Gap

Refer to Fig. (9). With the breaker closed, press the manual trip button allowing the breaker to trip open normally. Do not force the contacts open wider by hand. The gap between the stationary primary contacts (5) and the movable primary contact (6) should be  $3-13/16" + 1/8" - 3/16"$ . To change this gap, loosen the check nut (17), Fig. (5) and turn the adjusting nut (18) on stud (19). Screwing the adjusting nut down will decrease the primary contact gap. Tighten the check nut and remeasure the contact gap (close and trip the breaker before checking the measurement).

### Trip Latch Wipe

Refer to Fig. (5). The wipe of the trip latch (8) on the trip roller (9) should be from  $3/16"$  to  $1/4"$ . This can be measured by putting a film of grease on the latch (8), closing the breaker part way, and tripping. The mechanism has the proper trip latch wipe when the latch rests against the stop pin (23). No adjustment is provided and a visual inspection is usually all that is required. If this setting is not correct, look for insufficient travel of the trip shaft (7).

WHEN WORKING ON THE MECHANISM IN THE CLOSED POSITION, KEEP FINGERS CLEAR OF THE LINKAGE, AS ACCIDENTAL TRIPPING CAN CAUSE SEVERE INJURY.



Trip Latch Clearance

Refer to Fig. (5). With the breaker in the tripped position and the closing springs charged, check the clearance between the trip latch (8) and the trip roller (9). It should measure  $1/32''$  to  $1/16''$ .

Prop Clearance

Refer to Fig. (5). With the breaker closed as far as possible, that is, with the springs blocked and the cam (16) rotated so that the prop pin (13) is at its maximum height over the prop (14), the clearance between the prop and prop pin should be  $1/16''$  to  $5/32''$ . No adjustment is provided and a visual inspection is usually all that is required.

Release Latch Wipe

Refer to Fig. (6). The wipe between the release latch (3) and roller (2) should be  $3/16''$  to  $1/4''$ . If re-setting is required, loosen, set, and re-tighten adjustment nut and screw (4).

Release Latch Monitoring Switch

The release latch must be fully re-set and the monitoring switch operated before the motor will start. The switch should be wiped by the striker so that the clearance between the striker and switch mounting bracket (20) Fig. (6) is  $1/32''$  or less. To obtain this adjustment bend the switch striker. Be sure the latch is fully re-set before making any adjustments.

Motor and Relay Switches

With the closing springs blocked rotate the switch cam (1) Fig. (6) until the switch striker (8) has traveled the maximum amount (about 180 degrees rotation of cam). Loosen mounting bolt (14) and rotate switch support (15) until the gap between the striker (8) and support (15) is  $1/32''$  or less.

Interlock Switch Wipe

Refer to Fig. (10). Rotate the interlock shaft (1) manually clockwise to release the interlock switch arm (2). The point at which the contacts make can be determined with a circuit continuity tester such as a light indicator or bell set. To obtain adjustment on the interlock switch (3), bend the interlock switch arm (2) until there is a maximum of  $1/32''$  clearance to the switch mounting plate (4).

Auxiliary Switch

The auxiliary switch (9), Fig. (11) is mounted on the left side of the operating mechanism. The shaft of the position indicator (8) operates the auxiliary switch shaft which opens and closes the "a" and "b" contacts. The "a" contacts are open when the breaker is open and the "b" contacts are open when the breaker is closed. The "a" contacts should close when the breaker primary contact gap is a minimum of 1". The "b" contacts need only to be checked to see that they are open when the breaker is closed. No adjustment is provided and a visual inspection is usually all that is required.

### Driving Pawl Adjustment

The driving pawl (5) Fig. (4) must advance the ratchet wheel (3) Fig. (3) sufficiently on each stroke to allow the latching pawls (1) to fall into the ratchet teeth. This should be checked with the maximum closing spring load against the driving members. With the mechanism unblocked, hand charge the closing springs with the manual charging wrench until they are slightly more than half charged. Slowly rotate the charging wrench until the driving pawl (5) Fig. 4 has traveled through its return stroke and check the maximum clearance between the pawl and the ratchet tooth. Rotate the charging wrench until the driving pawl has advanced the ratched tooth to its maximum travel. Now check the clearance between the ratchet tooth and the latching pawl (1) Fig. (3). The clearance should be approximately equal for both the driving and latching pawls and not less than .015" in either case.

If adjustment is required for either pawl the springs must first be fully charged and blocked. Loosen seven motor support bolts (1) Fig. (15) and move entire motor assembly to the rear if the clearance is under the minimum at the latching pawls, and to the front if the clearance is under the minimum at the driving pawl. Move the motor assembly approximately twice the dimensional increase required at the pawl. Be certain the motor assembly is moved straight forward or rearward and tighten the one bolt on the right side of the mounting frame first to assure proper alignment. After tightening the remaining bolts the springs should be released and the clearance again checked as described above.

### AUXILIARY DEVICES

#### Latch Checking Switch

Refer to Fig. (12). Rotate the trip latch (4) clockwise (looking at the left side of the mechanism) by pressing the manual trip lever to open the latch checking switch operating arm (3). Allow the trip latch to reset slowly and determine the point at which the contacts make by using a circuit continuity tester, such as a light indicator or bell set. The contacts of the latch checking switch should just make when the gap between the trip latch (4) and the stop pin (5) located on the crank (7) is  $1/16"$ . There should be a minimum of  $1/64"$  between the operating arm (3) Fig. (12) and the switch support (1). To obtain adjustment of the latch checking switch (2) bend the latch checking switch operating arm (3).

#### Plunger Interlock

Refer to Fig. (13). With the breaker in the closed position, the vertical distance "A" from the top of the interlock bolt (1) to the bottom of the elevating bar (3) should be  $16-21/32"$  plus or minus  $1/16"$ . To change this adjustment, add or remove washers (2).

Spring Release Interlock

A spring release interlock shown in Fig. (14) will assure that the breaker contacts are open and the closing springs discharged when inserting or removing the breaker from the metal-clad unit. If the closing springs are charged and/or the breaker is in the closed position when being inserted or withdrawn from the metal-clad unit, the release interlock will trip the breaker open and hold the mechanism in a trip-free position while discharging the closing springs.

Auxiliary Fuses

Refer to Fig. (15). On breakers with "C" suffix, a set of protecting fuses (4) are mounted on the front of the breaker. These fuses will be the primary protection devices for the closing control circuits on those breakers that are used in metal-clad units designed for solenoid operated breakers.

Inspection and Test

1. For ease in reviewing the adjustments, the following are recapitulated:
  - a. Primary contact wipe:  $5/16" + 0 - 1/16"$ .
  - b. Arcing contact wipe:  $5/16"$  or greater (gap at primary contacts).
  - c. Primary contact gap:  $3-13/16" + 1/8" - 3/16"$ .
  - d. Trip latch wipe:  $3/16"$  to  $1/4"$  with trip latch resting against stop pin.
  - e. Trip latch clearance:  $1/32"$  to  $1/16"$ .
  - f. Prop clearance:  $1/16"$  to  $5/32"$ .
  - g. Release latch wipe:  $3/16"$  to  $1/4"$ .
  - h. Release latch monitoring switch: maximum clearance  $1/32"$ .
  - i. Motor and relay switch: maximum clearance  $1/32"$ .
  - j. Interlock switch: maximum clearance  $1/32"$ .
  - k. Auxiliary switch "a" contacts close when breaker primary contact gap is  $1"$  or greater.
  - l. Driving and Latching Pawl: minimum clearance to ratchet teeth  $.015"$ .
  - m. Latch checking switch contacts make when the gap between the trip latch and the stop pin is  $1/16"$ .
  - n. Plunger interlock:  $16-21/32"$  plus or minus  $1/16"$  with breaker closed.
2. Check all nuts, washers, bolts, cotter pins, and terminal connections for tightness.
3. Inspect all wiring to make sure that no damage has resulted during installation, and test for possible grounds or short circuits.
4. See that all bearing surfaces of the mechanism have been lubricated. Refer to the section on LUBRICATION.
5. Operate the breaker slowly with the manual charging wrench and note that there is no excessive binding or friction and that the breaker can be moved to the fully opened and fully closed positions.

6. See that any place where the surface of the paint has been damaged is repainted immediately.
7. Check the trip coil plunger and the release coil plunger to see that they move freely.

Opening and Closing Speeds

The closing speed of the arcing contact of the breaker should be a minimum of 11 feet per second. This represents the average speed of the movable arcing contact from a point 1" before the tip is tangent to the lower surface of the slot or probes on the upper arc runner to the tangent position.

The opening speed of the arcing contact should be a minimum of 12 feet per second. This represents the average speed over 3" from the point when the tip on the movable contact is tangent to the lower surface of the slot or probes on the upper runner.

Control Power Check

After the mechanism has been closed and opened slowly several times with the maintenance closing wrench and the mechanism adjustments are checked as described, the operating voltages should be checked at the release coil, trip coil, and motor terminals. For electrical operation of the mechanism, the control power may be either an alternating or direct current source. The operating ranges for the closing and tripping voltages are given on the breaker nameplate. The following ranges are standard:

Nominal Voltage	Closing Range		Tripping Range	
	Min.	Max.	Min.	Max.
48v d-c	34	50v d-c	28	60v d-c
110v d-c	80	115v d-c	60	125v d-c
125v d-c	90	130v d-c	70	140v d-c
220v d-c	160	230v d-c	120	250v d-c
250v d-c	180	260v d-c	140	280v d-c
115v a-c	95	125v a-c	95	125v a-c
230v a-c	190	250v a-c	190	250v a-c

If the closed circuit voltage at the terminals of the coil or motor does not fall in the specified range, check the voltage at the source of power and line drop between the power source and breaker.

When two or more breakers operating from the same control power source are required to close simultaneously, the closed circuit voltage at the closing coil or motor of each breaker must fall within the specified limits.

Electrical closing or opening is accomplished by merely energizing the closing or trip coil circuit. Control switches are provided for this purpose on the metal-clad unit. It is also possible to trip or close the breaker manually by pressing the manual trip lever (11) Fig. (2) or the manual close button (7).

Before the breaker is finally raised into position in the metal-clad unit, rub a small amount of G-E contact lubricant D50H47 on the silvered portion of the breaker studs to form a thin coating for contacting purposes.

### GENERAL MAINTENANCE

Dependable service and safer power equipment are contingent upon the unfailing performance of the power circuit breaker. To maintain such service, it is recommended that a definite inspection and maintenance schedule be set up and followed, as serious shutdowns can often be avoided by locating potential sources of trouble in an early stage. A periodic lubrication of parts subject to wear is also vitally important for the successful operation of the breaker.

BEFORE ANY MAINTENANCE WORK IS PERFORMED, MAKE CERTAIN THAT ALL CONTROL CIRCUITS ARE OPENED AND THAT THE BREAKER IS REMOVED FROM THE METAL-CLAD UNIT. DO NOT WORK ON THE BREAKER OR MECHANISM WHILE IN THE CLOSED POSITION UNLESS THE PROP AND TRIP LATCH HAVE BEEN SECURELY WIRED OR BLOCKED TO PREVENT ACCIDENTAL TRIPPING. DO NOT WORK ON THE BREAKER OR MECHANISM WHILE THE SPRINGS ARE CHARGED UNLESS THEY ARE SECURED IN THAT POSITION BY THE MAINTENANCE SPRING BLOCKING DEVICE.

### Periodic Inspection

The frequency of periodic inspection should be determined by each operating company on the basis of the number of operations (including switching), the magnitude of currents interrupted, and any unusual operations which occur from time to time. Operating experience will soon establish a maintenance schedule which will give assurance of proper breaker condition. On installations where a combination of fault duty and repetitive operation is encountered, an inspection is recommended after any severe fault operation. The following instructions list the main points to be included in an inspection and, a number of general recommendations.

### Arc Chutes

It is not necessary to inspect the arc chutes unless there is evidence of damage or if the arc chutes are removed for any reason. When inspecting an arc chute, it should be disassembled and the following points noted:

1. Scale formed over the surface of the arc chute must not be removed, but loose particles collected in the chute should be blown out.
2. Cracks which have formed in the fins of the arc chute are to be expected in ceramic materials of this type when subjected to the severe heat of an arc. These cracks do not interfere with the operation of the device in any way and should be disregarded.

3. If the arc chute has suffered any mechanical injury due to dropping or accidental striking, resulting in the actual breaking off of fins, replacement of the chute will be necessary. Small broken corners on the exhaust end of the chute will not interfere with its performance and can also be disregarded.
4. The plastisol flexible covering for the pole pieces (17 & 18) Fig. (16) and the upper mounting support (10) Fig. (16) should be inspected for breaks in the insulation. If there are holes or breaks in the insulation they should be repaired or the part replaced.

### Breaker Contacts

By removing the box barrier the movable and stationary primary contacts and the movable arcing contacts can be inspected. The stationary arcing contacts can be inspected only after removing the arc chute assembly, as explained under REPAIR AND REPLACEMENT. If the contacts are burned or pitted, they should be made smooth with a fine file.

After completing inspection of the contacts, check the contact adjustments as specified under ADJUSTMENTS.

### Mechanism

A careful inspection should be made to check for loose nuts or bolts and broken retaining rings. All cam, roller, and latch surfaces should be inspected for any evidence of damage or excessive wear. Lubricate the mechanism as outlined below, then, using the manual charging wrench, open and close the breaker several times to make certain that the mechanism operates freely throughout its entire stroke. Check the mechanism adjustments as specified under ADJUSTMENTS. Check all terminal connections.

### Bushings and Insulation

The surface of the bushings should be kept clean and unmarred to prevent moisture absorption. If the insulation surface should become damaged, it should be sanded and cleaned, and should be refinished with either clear varnish or clear resin. Allow to dry smooth and hard.

All other insulation parts on the breaker should be kept clean and dry. Smoke or dust collected between inspection periods should be wiped off, and if dampness is apparent, heaters should be installed to insure dryness.

### Insulation Test

When insulation has been repaired or replaced, or when breaker has been stored under adverse conditions, it is recommended that the insulation be checked before the breaker is placed in service. A standard 60 cycle high potential test at 14,000 volts RMS will normally indicate whether the breaker is satisfactory for service. With the breaker contacts in the fully open position, apply the high potential to each terminal of the breaker individually for one minute with all other terminals and the breaker frame grounded. After high potential

tests are made on organic insulating materials, these materials should be inspected for visible leakage current paths, and necessary action must be taken to replace insulation that may have been affected by moisture absorption.

If the breaker secondary wiring is to be given a hi-potential test at 1500 volts, remove both of the motor leads from the terminal board. Failure to disconnect the motor from the circuit may cause damage to the winding insulation.

### LUBRICATION

In order to maintain reliable operation, it is important that all circuit breakers be properly lubricated at all times. Most of the bearings and rolling surfaces utilize a new type of dry lubrication that will require no maintenance and will last the life of the equipment. Only few bearings and surfaces listed in the chart Fig. (20) require lubrication. These have been properly lubricated, during assembly at the factory, using the finest grades of lubricants available. However, even the finest oils and greases have a tendency to oxidize with age, as evidenced by hardening and darkening in color. Elimination of the hardened lubricant is essential for the proper operation of circuit breakers. Also frequent operation of the breaker causes the lubricant to be forced out from between the bearing surfaces. A simple lubrication will often clear up minor disturbances which might be mistaken for more serious trouble.

A definite lubrication schedule should be set up taking into consideration the frequency of operation of the breaker and local conditions. Until such a schedule is worked out, the breaker should be lubricated at each periodic inspection and also whenever it is overhauled, in accordance with the lubrication chart, Fig. (20). It is also recommended that all circuit breakers be operated at regular intervals to insure the user that the equipment is operating freely.

The lubrication chart, Fig. (20) is divided into two methods of lubrication. The first method outlines the maintenance lubrication which should be performed at the time of periodic maintenance, and requires no disassembly. The second method outlines a lubrication procedure similar to that performed on the breaker at the factory, but should be used only in case of a general overhaul or disassembly for other reasons, or if the operation of the breaker becomes slower.

General Electric Lubricants D50H15 and D50H47 are available in 1/4# collapsible tubes. It is so packaged to insure cleanliness and to prevent oxidation.

### Method of Cleaning Bearings

Whenever cleaning is required, as indicated in the lubrication chart, the following procedures are recommended:

#### Sleeve Bearings

The sleeve bearings used throughout the linkage utilize Teflon surfaces and do not require lubrication. After a number of operations, the surface will acquire a thin black film. Do not remove this film unless there is evidence of outside contaminants, such as dry or hardened grease. If contami-

nants are present they should be removed by immersing the link and bearing in clean petroleum solvent or similar cleaner and using a stiff brush. Do not remove the bearings from the links. DO NOT USE CARBON TETRACHLORIDE.

The hinge of the primary contact arm (24) Fig. (7) should be disassembled, cleaned, and lubricated with G-E D50H47 lubricant at general overhaul periods.

The main shaft bearings (24) Fig. (5) and the driving pawl lever bearing should be removed, cleaned, and lubricated with G-E D50H15 lubricant at general overhaul periods.

### Roller & Needle Bearings

The cam follower bearings (6) Fig. (5), latch roller bearing (9), and cam shaft bearings (25) Fig. (5) should be first removed from the mechanism and the inner race disassembled. They should then be placed in a container of clean petroleum solvent or similar cleaner. DO NOT USE CARBON TETRACHLORIDE. If the grease in the bearings has become badly oxidized, it may be necessary to use alcohol (type used for thinning shellac) to remove it. Ordinarily, by agitating the bearings in the cleaning solution, and using a stiff brush to remove the solid particles, the bearings can be satisfactorily cleaned. Do not handle the bearings with bare hands as deposits from the skin onto the bearings are inductive to corrosion. If the bearings are touched, the contamination can be removed by washing in alcohol. After the bearings have been thoroughly cleaned, spin them in clean new light machine oil until the cleaner or solvent is entirely removed. Allow this oil to drain off and then repack them immediately with G-E lubricant D50H15 being sure all metal parts are greased. The removable seals should then be replaced.

NOTE: If it becomes necessary to clean the bearings in alcohol (shellac thinner), be sure the alcohol is perfectly clean, and do not allow the bearings to remain in the alcohol more than a few hours. If it is desirable to leave the bearings in the alcohol for a longer time, an inhibited alcohol such as is used for anti-freeze should be used. Even then the bearings should be removed from the alcohol within twenty-four hours. Esso Anti-Freeze and Du Pont Zerone are satisfactory for this purpose. Precautions against the toxic effects of the alcohol must be exercised by wearing rubber gloves and by using the alcohol in a well ventilated room; excessive exposure to the fumes is sometimes unpleasant to personnel. Washing the bearings in the light oil and draining should follow immediately, then apply the lubricant.

Bearings that are pressed into the frame or other members such as the eccentric drive bearings (7) Fig. (15) should not be removed. After removing the shaft and inner race the bearing can usually be cleaned satisfactorily with petroleum solvent or a similar cleaner and a stiff brush. Follow the procedure outlined above using a light machine oil and G-E lubricant D50H15 before reassembling the inner race and shaft.

### Rolling Surfaces

A number of rolling and rubbing surfaces in the mechanism have been lubricated with a baked-on, dry, molybdenum disulfide coating. This requires no maintenance and should last the life of the breaker.



RECOMMENDED MAINTENANCE FOR MAGNE-BLAST BREAKERS APPLIED TO REPETITIVE SWITCHING DUTY

1. Magne-blast breakers applied to repetitive operation such as switching arc furnaces and motors should be serviced and maintained according to the following schedule:
  - A. Every 2000 Operations, or Every Six Months - Whichever Comes First
    1. Remove the box barriers.
    2. Wipe all insulating parts clean of smoke deposit and dust, with a clean dry cloth, including the bushings, and the inside of the box barriers.
    3. All areas in the throat area of the arc chute should be thoroughly cleaned by using sandpaper. This cleaning should be performed any time the arc chute is removed. The arc chute fins should not be cleaned. Whenever the arc chute is removed, loose dust and dirt should be blown out before replacing arc chutes.
    4. Primary Contacts - Inspect the condition of the stationary contact fingers and movable contact blocks. Badly pitted or burned contacts should be replaced. (Note: Burned primary contacts indicate the probable need for arcing contact replacement). If the contact surfaces are only roughened or galled, they should be smoothed with crocus cloth or draw filed. After contact dressing the primary contacts should be greased lightly with D50H47.
    5. Arcing Contacts - When the arcing contact wipe is less than the minimum specified under ADJUSTMENTS, the contacts should be replaced. The contacts should be inspected for uneven wear and/or damage using a mirror to inspect the stationary contacts. Normally it will not be necessary to remove the arc chutes for this 2000 operation servicing unless inadequate wipe or contact condition indicate a need for replacement. When the arc chutes are removed, the contact braids, coil protectors, and other parts subject to arcing should be checked for possible cleaning or replacement. Do not grease the arcing contacts under any circumstances.
    6. Check the breaker and mechanism adjustments as summarized under INSPECTION AND TEST. The necessary readjustments should be made as described under ADJUSTMENTS.
    7. The breaker and operating mechanism should be carefully inspected for loose nuts, bolts, retaining rings, etc., all cam, latch and roller surfaces should be inspected for damage or excessive wear. The buffer blocks and their retainers on the bottom of the stationary contact support should be inspected for possible need of replacement.

8. The contacts of the control relay should be inspected for wear and cleaned if necessary.
9. Lubricate the breaker operating mechanism in accordance with the table under LUBRICATION.
10. Inspect all wiring for tightness of connections and possible damage to insulation.
11. After the breaker has been serviced, it should be slowly closed and opened, as described in INSTALLATION, to be sure there is no binding or friction and that the breaker contacts can move to the fully opened and fully closed positions. Its electrical operation should then be checked using either the test cabinet or the test couplers.

#### B. After Every 10,000 Operations

1. In addition to the servicing done each 2,000 operations, the arc chutes should be removed from the breaker and disassembled to permit a detailed inspection of insulation, blow-out coils, arc runners and assemblies which can become contaminated by arc products.
2. The blow-out coils should be carefully examined and if the insulation has been cracked, shrunk or eroded from arc action and heat so that the turns of the coils are not fully insulated from each other, the coils should be replaced. All connections should be checked for tightness.
3. The arc runners should be inspected and replaced when any part of their area has been reduced to 25% of the original metal thickness as a result of arc erosion.
4. Check the stationary arc contacts to assure that the arcing contacts are in good condition and that their connections are tight.
5. Insulating material that is carbonized and cannot be satisfactorily cleaned should be replaced.
6. Any parts damaged or severely burned and/or eroded from arc action should be replaced.

NOTE: Fine cracks may develop in the fins of the arc chute sides. This is to be expected with ceramic materials when subjected to the high heat of an arc and may be disregarded unless they are long and present a possibility of fin sections breaking completely off. Small broken corners on the exhaust end of the arc chute will not interfere with its performance and can also be disregarded.

7. The cup bearing and the contact ring at the hinge point of the contact blade should be disassembled, inspected, cleaned, and re-lubricated with G-E contact lubricant D50H47. The contact ring should be inspected for wear and replaced when reduced in thickness to less than 1/32".

C. Every 20,000 Operations or Approximately Every Five Years - Which-ever Comes First

1. At this time the breaker should be given a general overhaul and all excessively worn parts in both the mechanism and breaker replaced. Such wear will usually be indicated when the breaker cannot be adjusted to instruction book tolerances. This overhaul and inspection is more detailed and will require disassembly of mechanism and breaker operating parts.
  2. All roller and needle bearings in the operating mechanism should be disassembled, cleaned, and repacked with G-E lubricant D50H15 as described under LUBRICATION.
  3. The stationary primary contact fingers should be disassembled and the silver-plated pivot area of the contact and contact support cleaned and lubricated with G-E lubricant D50H47.
  4. The breaker and operating mechanism should be serviced as described for every 2,000 operations and properly adjusted before being put back into service.
2. Magne-blast breakers applied to repetitive operation such as capacitor switching should be serviced and maintained according to the preceding recommendations, and in addition, should have items 1A1, 1A2, and 1A3 repeated at 500 operation intervals.

TROUBLE SHOOTING

Failure of a breaker to operate properly will generally fall within four general classes; failure to trip, failure to close or latch closed, closing springs will not recharge, and overheating. The following is a brief outline showing particular types of distress that might be encountered, together with suggestions for remedying the trouble:

Failure to Trip

1. Mechanism binding or sticking caused by lack of lubrication.  
REMEDY: Lubricate complete mechanism.
2. Mechanism binding or sticking caused by being out of adjustment.  
REMEDY: Check all mechanism adjustments, latches, stops, auxiliary devices, etc., in accordance with section on ADJUSTMENTS. Examine latch and roller surfaces for corrosion.
3. Damaged trip coil.  
REMEDY: Replace damaged coil.
4. Blown fuse in trip circuit.  
REMEDY: Replace blown fuse after determining cause of failure.
5. Faulty connections in trip circuit.  
REMEDY: Repair broken or loose wires and see that all binding screws are tight.
6. Damaged or dirty contacts in trip circuit.  
REMEDY: Recondition or replace contacts.

### Failure to Close or Latch Closed

1. Mechanism binding or sticking caused by lack of lubrication.  
REMEDY: Lubricate complete mechanism.
2. Mechanism binding or sticking caused by being out of adjustment.  
REMEDY: Check all mechanism adjustments, latches, stops, auxiliary devices, etc., in accordance with section on ADJUSTMENTS. Examine latch and roller surfaces for corrosion.
3. Damaged or dirty contacts in control circuit including control relay.  
REMEDY: Recondition or replace contacts.
4. Damaged spring release coil.  
REMEDY: Replace damaged coil.
5. Defective latch-checking switch, or interlock switch.  
REMEDY: Replace defective switch.
6. Blown fuse in closing circuit.  
REMEDY: Replace blown fuse after determining cause of failure.
7. Faulty connections in closing circuit.  
REMEDY: Repair broken or loose wires and see that all binding screws are tight.
8. Insufficient control voltage caused by excessive drop in leads.  
REMEDY: Install larger wires and improve electrical contact at connections.
9. Insufficient control voltage caused by poor regulation (a-c control).  
REMEDY: Install larger control transformer.

### Failure to Recharge Springs

1. Defective motor cut-off switch, interlock switch, or closing latch monitoring switch.  
REMEDY: Replace switch.
2. Damaged or dirty contacts in control circuit.  
REMEDY: Recondition or replace contacts.
3. Blown fuse in closing circuit.  
REMEDY: Replace blown fuse after determining cause of failure.
4. Faulty connection in charging circuit.  
REMEDY: Repair broken or loose wires and see that all binding screws are tight.

### Overheating

1. Poor condition of contacts due to lack of attention after severe duty or too frequent operation.  
REMEDY: Recondition or replace burned and pitted contacts. (Contacts should be reconditioned very carefully and only when absolutely necessary.)

2. Contacts not properly aligned or adjusted.  
REMEDY: Check all adjustments in accordance with section on ADJUSTMENTS.
3. Breaker kept closed or open for too long a period.  
REMEDY: Operate breaker more often to wipe contacts clean. Replace contacts if necessary.
4. Overloading.  
REMEDY: Replace breaker with one of adequate rating for present or future load, or re-arrange circuits so as to remove excess load.
5. Primary connections of inadequate capacity.  
REMEDY: Increase size or number of conductors or remove excess current.
6. Loose connections or terminal connectors.  
REMEDY: Tighten.
7. Ambient temperature too high.  
REMEDY: Relocate in a cooler place or arrange some means of cooling.

#### REPAIR AND REPLACEMENT

The following information covers in detail the proper method of removing various parts of the breaker in order to make any necessary repairs. This section includes only those repairs that can be made at the installation on parts of the breaker that are most subject to damage or wear. IMPORTANT: UPON COMPLETION OF ANY REPAIR WORK, ALL BREAKER AND MECHANISM ADJUSTMENTS MUST BE CHECKED. Refer to the section on INSTALLATION, paying particular attention to ADJUSTMENTS and FINAL INSPECTION.

#### Arc Chute (To inspect or replace blow-out coils)

To remove an arc chute, first open the breaker and remove the box barrier (7), Fig. (7). Loosen the two upper supporting bolts (2) Fig. (19) and the one lower support bolt (9) using a 3/4" wrench. By raising the complete arc chute assembly about 3/8" and sliding it toward the rear of the breaker, it can be removed as shown in Fig. 19.

To disassemble the arc chute after it has been removed from the breaker, proceed as follows:

1. Remove the caps and assembly bolts (7, 9, 11, and 13), Fig. 16.
2. Remove the side brace (5) and pole pieces (3 and 17), Fig. 16.
3. To remove the upper mounting support (10), Fig. 16 remove the assembly bolt (1), Fig. 16 and connection bolt (2), Fig. 18.
4. Remove the assembly bolts (16), Fig. 16 to remove the lower brace (8).
5. Remove the lower mounting support (14), Fig. 16 by removing the assembly bolts (15) and the connection nut (9), Fig. 18.
6. At this point the side shields (12), Fig. 16, the upper arc runner assembly (4), Fig. 18 and lower arc runner assembly (7) can be removed.

7. Further disassembly of both the upper and lower arc runner assemblies can be done by removing the various screws and 1/4" assembly bolts (not illustrated) as shown in Fig. 17.
8. The arc chute sides (7) Fig. 17 can be separated by removal of assembly bolts (2 and 4), Fig. 16.

Reassemble the arc chute in the reverse order. The following items should be noted during reassembly:

1. Equally space the fins of the arc chute sides before bolting together. Fig. 21.
2. Check to insure that electrical connections to the blowout coils are tight.
3. When reassembling the arc runner assemblies, check that the spacers (1 and 13), Fig. 17 are correctly installed.
4. Before bolting the upper mounting support in place, make certain that the upper arc runner assembly is tight against the arc chute side so that the gap between the upper insulation (8), Fig. 17, and the arc chute side (7) is a minimum.
5. Make certain that the electrical connections (2 and 9), Fig. 18 are tight.

To reassemble the arc chute to the breaker proceed as follows:

1. Rest the lower mounting support (10) on the arc chute mounting bracket (8) as shown in Fig. 19.
2. Slide the arc chute forward and lift it slightly to engage the supporting bolts (2), Fig. 19, in the slots of the upper mounting support (3).
3. Check the spring baffle (11) Fig. 22, to assure that it closes the gap between the upper insulation (18), Fig. 16, and the back of the contact support (4), Fig. 22. (-6C and 6H designs only)
4. Tighten the supporting bolts (2 and 9), Fig. 19. These bolts serve as both the electrical and mechanical connections between the bushing and the arc runners.
5. Check that the movable arcing contact (5), Fig. 19, passes through the slot or between the probes on the upper arc runner (5), Fig. 18, without touching.

#### Contacts

Open the breaker and remove the box barrier and arc chutes as previously described. To remove the contacts, proceed as follows:

##### A. Stationary Arcing Contacts (10), Fig. 22.

1. Disconnect the contact braids from contact fingers by removing two bolts (8), Fig. 22.

2. Grasp the lower end of the contact fingers with pliers and pull contact assembly downward to remove from stud assembly.
3. To disassemble braids from stud assembly, remove one bolt (5).
4. To disassemble stud assembly from contact support, remove two bolts (6).
5. Reassemble in the reverse order.

B. Stationary Primary Contacts (9), Fig. 23

1. Compress the contact spring (6).
2. Remove spring and spring guide (1).
3. Raise the contact finger to clear the primary contact stop plate (8) and lift the finger out of contact support (7). Remove one contact finger at a time.

To replace the Stationary Primary Contacts:

1. Apply a thin coating of D50H47 grease on the hinged edge of the finger (9) then place it on the contact support (7) so that it is retained by stop plate (8).
2. Open spring compressor (3) and assemble spring guide, spring and spring compressor (Fig. 23A).
3. Turn nut (2) in clockwise direction to compress contact spring (Fig. 23B). Hold spring firmly in yoke on spring compressor to prevent spring from slipping out of the compressor.
4. Place washer (not shown) on guide on top of spring, place top of guide into hole in spring retainer (4) and the round end of spring guide in cutout in primary finger (Fig. 23C).
5. Hold spring assembly firmly in place and remove spring compressor.

C. Movable Arcing Contact (7), Fig. 24

1. Remove the assembly bolts (8).
2. Reassemble in reverse order.

D. Movable Primary Contacts (5), Fig. 24  
(All 1200 Amp Breakers & 2000 Amp -7 Breakers)

1. Remove the nuts from assembly bolts (6).
2. Remove the primary contacts.
3. Reassemble in reverse order.  
(2000 Amp -6 Breakers).

1. Remove the nuts from assembly bolts (6).

2. Remove the connection bar (9).
  3. Remove the cup bearing (3).
  4. Spread the contact arms (4) and remove the primary contacts (5).
  5. Reassemble in the reverse order.
- E. Contact Blade Assembly (4, 5, 7) Fig. 24
1. Remove the connection bar (9).
  2. Remove the cup bearing (3) and the pin (11).
  3. When reassembling, first insert the piston assembly (10), into the booster cylinder and reassemble the cup bearing (3).
  4. Replace pin (11), and connection bar (9).
- F. After disassembly and reassembly of any contacts, check all contact adjustments as described under ADJUSTMENTS.

### Bushings

**IMPORTANT:** DO NOT REMOVE ALL SIX BUSHINGS AT ONCE. The bushings have been carefully aligned with the breaker frame, during assembly at the factory, and it is important that this alignment be maintained to facilitate installation of the breaker in the metal-clad unit. It is, therefore, recommended that the bushings be removed and reassembled one at a time. Also, before removing any one bushing, measure the distance from that particular bushing to adjacent bushings in both directions, so that it may be reinstalled in the same location.

It is also possible to remove and reassemble three bushings at one time. If this is preferred, alignment of the bushings may be accomplished by placing the breaker in a de-energized spare metal-clad unit before tightening the bushing mounting bolts. This must be done before the arc chutes are reinstalled.

To replace the bushing, proceed as follows:

### Rear Bushing

1. Open the breaker and remove the box barrier and arc chutes as already described.
2. Remove the upper and lower horizontal barriers (18 and 20), Fig. 7.
3. Remove the four bolts at the mounting flange of the rear bushing being removed and lower the bushing assembly.
4. Referring to Fig. 23 disassemble the primary contact springs (6) as previously described.
5. Disassemble the spring retainer (4) by removing mounting bolts (5).



6. Referring to Fig. 22, disassemble the contact support (4) and arc chute mounting bracket (2) by removing two bolts (3).
7. Reassemble in the reverse order. The arc chute mounting bracket (2) is not symmetrical and must be assembled correctly to orient the chute properly on the breaker. The longest projection of the bracket should be toward the lower end of the bushing.

#### Front Bushing

1. Open the breaker and remove the box barrier and arc chutes as already described.
2. Remove the upper and lower horizontal barriers (18 and 20) Fig. 7.
3. Remove the connection bar (9), Fig. 24, cup bearing (3), and pin (11).
4. Remove the four bolts at the mounting flange of the front bushing being removed, and lower the bushing.
5. When reassembling, first mount the bushing and assemble the cup bearing (3) contact arm (4), and replace pin (11). The contact surfaces at the hinge point of the contact blade and bushing should have a thin coating of D50H47 grease.
6. Check all contact adjustments as outlined under ADJUSTMENTS.

#### INTERLOCK SWITCH

To remove the interlock switch (3), Fig. 10 remove the two mounting screws and disconnect the lead wires. Reassemble in the reverse order and check the switch adjustments as explained under ADJUSTMENTS.

#### LATCH CHECKING SWITCH

To remove the latch checking switch (7), Fig. 10 (when furnished), remove the two mounting screws and disconnect the lead wires. Reassemble in the reverse order and check the switch adjustments as explained under ADJUSTMENTS.

#### MOTOR, RELAY and LIGHT SWITCHES

The three switches are mounted in tandem as shown in Fig. (6).

1. Remove the opening spring per instructions below.
2. Remove (2) mounting bolts (14) from switch bracket (15).
3. Remove the (2) mounting screws of the lower switch.
4. Remove the (2) mounting screws of the center switch.
5. Remove the (2) mounting screws of the upper switch.
6. Disconnect the lead wires of switch to be replaced.
7. Reassemble in the reverse order and check switch adjustment as explained under ADJUSTMENTS.

### TRIP SHAFT AND LATCH

1. Remove latch checking switch arm (10) Fig. 11 (when supplied).
2. Remove cotter pins on both ends of the shaft (12).
3. Remove set screw in latch (11).
4. Remove trip coil linkage bolt (6).
5. Place a block between the latch and frame (either side) and drive shaft until the latch is free of the key.
6. Remove key and all burrs that may be raised around the keyway on the shaft. Burrs will scar or shave the Teflon bearing surfaces if they are not removed.
7. Reassemble the parts in the reverse order. Be sure the latch spring is properly installed and the latch is aligned in the center of the latch roller. Check latch adjustment as described under ADJUSTMENTS.

### TRIP LATCH ROLLER BEARING

1. Remove (2) cotter pins at ends of shaft (8) Fig. 12.
2. Partially remove shaft out right side of frame until latch roller (6) is free.
3. Reassemble in reverse order with proper spacing of washers. Be sure latch roller rotates freely.

### CLOSING LATCH

1. Remove cotter pins at both ends of latch shaft (19) Fig. 6.
2. Remove spring and paddle (16) Fig. 6.
3. Remove set screws from latch (3) Fig. (6).
4. Move shaft (14) to left (away from frame) by tapping lightly on the inside end of shaft. Rotate shaft and continue tapping until shaft is free. Shaft will push outside needle bearing from housing.
5. Reassemble in reverse order putting bearing into frame last. Use a small piece of tubing or pipe when inserting bearing to assure proper alignment.
6. Check latch adjustments as described under ADJUSTMENTS.

### MOTOR SUPPORT

1. To remove motor support (8) Fig. (15) first remove the latch spring (16) Fig. (6).

2. Remove the retaining ring (9) Fig. (15) and link (10).
3. Remove motor leads from the terminal board.
4. Remove six 3/8" bolts (1) Fig. (15) on bottom and one 3/8" bolt on the right side (not shown).
5. Remove four mounting bolts from motor (not shown).
6. Remove the retaining ring (7) from the eccentric (2) Fig. (15).
7. Reassemble all parts of the motor support in the reverse order and re-align it properly as described under DRIVING PAWL ADJUSTMENTS.

#### CAM

1. Remove 2 set screws from ratchet wheel (3) Fig. (3) and remove wheel from main shaft (8).
2. Remove 2 set screws from cam (12) Fig. (1).
3. Remove prop reset spring (10) Fig. (2).
4. Remove 2 set screws from cam (16) Fig. (5) and move cam to the right on the shaft as far as it will go. Slide the shaft to the left until key is fully exposed. Remove key and check shaft for burrs.
5. Remove shaft out left side of frame.
6. Reassemble in reverse order using the correct number of washers and spacers to properly locate the parts.
7. Rotate the mechanism through a closing operation using the manual charging wrench. Check the location of the cam follower (6) Fig. (5) on the cam (16). If necessary, move the cam to correct the alignment. Complete the closing operation and check the location of the prop pin (13) Fig. (5) on the prop (14). It should be approximately centered.

#### TRIP COIL

To replace the potential trip coil (2) Fig. (11) proceed as follows:

1. With the breaker in the open position, remove the two mounting bolts (3).
2. Remove upper support (1) and spacers.
3. Cut wires at the butt connectors and remove coil.
4. When replacing the coil be sure to assemble the correct fiber spacers at the ends before bolting support (1).

5. Adjust coil location to allow approximately 1/4" of armature travel before latch starts to move.
6. Butt connect wires and check operation of solenoid electrically and mechanically.

#### SPRING RELEASE COIL

To remove the spring release coil (5) Fig. (6) proceed as follows:

1. Block the closing springs as described in INSTALLATION.
2. Remove the left hand closing spring as described in CLOSING SPRING below.
3. Remove two mounting bolts (17), coil support (18), and spacers.
4. Cut wires at the butt connectors and remove coil.
5. Replace the coil and the correct number of fiber spacers before bolting support.
6. Butt connect wires and check that the armature is not binding. Check coil for electrical operation.

#### CLOSING SPRINGS

The closing springs (6) Fig. (3) can be removed as follows:

1. Charge the springs with the manual charging wrench and apply the spring blocking device as described in INSTALLATION.
2. Discharge springs by pushing manual close button (7) Fig. (2).
3. Rotate cam shaft (8) Fig. (3) by using the manual charging wrench until the gap between the spring (6) and the bearing block (10) is 2 inches or more.
4. Lift both springs until they clear the lower supports, then pull forward and down until the top supports are free.
5. Either discharge the opening springs by pushing the manual trip lever or block the opening springs with a suitable blocking device.

#### OPENING SPRINGS

To remove the opening springs (9) Fig. (3) proceed as follows:

1. Charge and block the closing springs as described under INSTALLATION.
2. Push manual trip lever (11) Fig. (2) to be sure the opening springs are fully discharged.
3. Remove upper pin (12) Fig. (3) and lower pin (11).
4. After reassembling springs check the primary opening as described under PRIMARY CONTACT GAP.

RENEWAL PARTS

It is recommended that sufficient renewal parts be carried in stock to enable the prompt replacement of any worn, broken, or damaged parts. A stock of such parts minimize service interruptions caused by break-downs, and saves time and expense. When continuous operation is a primary consideration, more renewal parts should be carried, the amount depending upon the severity of the service and the time required to secure replacements.

Renewal parts which are furnished may not be identical to the original parts, since improvements are made from time to time. The parts which are furnished, however, will be interchangeable.

The Renewal Parts List covers the following types of breakers:

AM-4.16-250-6C	1200A & 2000A
AM-4.16-250-6CR	1200A & 2000A
AM-4.16-250-6H	1200A & 2000A
AM-4.16-250-6HR	1200A & 2000A
AM-4.16-250-7C	1200A & 2000A
AM-4.16-250-7CR	1200A & 2000A
AM-4.16-250-7H	1200A & 2000A
AM-4.16-250-7HR	1200A & 2000A
AM-4.16-250-7HB	1200A & 2000A
AM-4.16-250-7HBR	1200A & 2000A

NOTE: The listed terms "Right" and "Left" apply when facing the mechanism end of the breaker.

ORDERING INSTRUCTIONS

1. Always specify the complete nameplate data of both the breaker and the mechanism.
2. Specify the quantity, catalog number (if listed), reference number (if listed), and description of each part ordered, and this bulletin number.
3. Standard hardware, such as screws, bolts, nuts, washers, etc., is not listed in this bulletin. Such items should be purchased locally.
4. For prices, refer to the nearest office of the General Electric Company.

PARTS RECOMMENDED FOR NORMAL MAINTENANCE

In the tabulation below are listed the parts of those breakers which are usually recommended for stock for normal maintenance.

Fig. No.	Ref. No.	Ampere Rating	Type	Catalog No. for Type AM-4.16-(MVA)-		No. Req'd	Description		
				-6 Design	-7 Design				
7	21	All	**	0281B0708	G-002	0281B0708	G-002	3	Operating Rod
7	21	All	B			0281B0708	G-008	3	Operating Rod
16	11	All	All	000421711	P-001	000421711	P-001	6	Insulating Cap
16	11	All	All	000407193	P-001	000407193	P-001	6	Washer (For Insulating Cap)
17	8	All	All	0414A0117	P-001			6	Throat Insulation
17	8	All	All			0108B1965	G-001	3	Throat Insulation (Right)
17	8	All	All			0108B1965	G-002	3	Throat Insulation (Left)
17	15	All	All	0383A0932	P-001	0161A5906	P-001	6	Lower Shield
17	16	All	All	0258C0616	P-009	0836C0197	P-014	6	Upper Runner Insulation
17	17	All	All	0258C0616	P-006	0114C5381	P-001	6	Lower Barrier
18	4	All	All	0414A0616	P-002	0114C5381	P-004	3	Insulating Plate
22	7	All	All	0236C0791	G-001	0236C0791	G-001	3	Flexible Connection (Right)
22	7	All	All	0236C0791	G-004	0236C0791	G-004	3	Flexible Connection (Left)
22	10	All	All	0236C0790	G-009	0236C0790	G-009	3	Arcing Contact Assembly
22	12	All	All	0414A0116	P-004	0414A0116	P-004	3	Insulating Plate
24	1	1200	All	0121A5964	P-001			12	Primary Contact Finger Spring
24	1	2000	All	006509787	P-001			24	Primary Contact Finger Spring
24	1	All	**			0121A5964	P-001	18	Primary Contact Finger Spring
24	1	All	B			0121A5964	P-001	24	Primary Contact Finger Spring
24	2	1200	All	0236C0791	P-008			12	Primary Contact Finger
24	2	2000	All	0236C0791	P-008			24	Primary Contact Finger
24	2	All	**			0114C5382	P-002	18	Primary Contact Finger
24	2	All	B			0114C5382	P-002	24	Primary Contact Finger
24	5	1200	All	0137A9164	P-003			3	Movable Primary Contact
24	5	2000	All	0137A9164	P-003			6	Movable Primary Contact
24	5	1200	All	0137A9164	P-004			3	Movable Primary Contact
24	5	2000	All	0137A9164	P-004			6	Movable Primary Contact
24	5	All	**			0114C5382	P-004	6	Movable Primary Contact
24	5	All	B			0137A9164	P-003	6	Movable Primary Contact
24	5	All	B			0137A9164	P-004	6	Movable Primary Contact
24	7	All	**	0802B0742	G-001	0802B0742	G-001	3	Movable Arcing Contact
24	7	All	B			0802B0742	G-002	3	Movable Arcing Contact
24	10	1200	All	0213X0343	G-043	0213X0343	G-043	3	Tube and Piston Assembly
24	10	2000	All	0213X0343	G-044	0213X0343	G-044	3	Tube and Piston Assembly
6	12	All	All	0105C9393	P-001	0105C9393	P-001	1	Motor - 48 V-dc
6	12	All	All	0105C9393	P-002	0105C9393	P-002	1	Motor - 110 & 125 V-dc & 115 V-ac
6	12	All	All	0105C9393	P-003	0105C9393	P-003	1	Motor - 220 & 250 V-dc & 230 V-ac
6	6	All	All	0137A7575	P-043	0137A7575	P-004	Δ 1	Relay - 48 V-dc
6	6	All	All	0137A7575	P-042	0137A7575	P-001	Δ 1	Relay - 110 & 125 V-dc
6	6	All	All	0137A7575	P-041	0108B1978	G-001	Δ 1	Relay - 220 & 250 V-dc
6	6	All	All	0137A7575	P-047	0137A7575	P-005	Δ 1	Relay - 115 V-ac
6	6	All	All	0137A7575	P-045	0137A7575	P-002	Δ 1	Relay - 230 V-ac
11	2	All	All	006174582	G-001	006174582	G-001	1	Potential Trip Coil - 110 & 125 V-dc
11	2	All	All	006174582	G-015	006174582	G-015	1	Potential Trip Coil - 220 V-dc
11	2	All	All	006174582	G-002	006174582	G-002	1	Potential Trip Coil - 250 V-dc
11	2	All	All	006174582	G-010	006174582	G-010	1	Potential Trip Coil - 115 V-ac
11	2	All	All	006174582	G-014	006174582	G-014	1	Potential Trip Coil - 230 V-ac
11	2	All	All	006275070	G-001	006275070	G-001	1	Potential Trip Coil - 24 V-dc
11	2	All	All	006275070	G-002	006275070	G-002	1	Potential Trip Coil - 48 V-dc
6	5	All	All	006174582	G-001	006174582	G-001	1	Spring Release Coil - 110 & 125 V-dc
6	5	All	All	006174582	G-015	006174582	G-015	1	Spring Release Coil - 220 V-dc
6	5	All	All	006174582	G-002	006174582	G-002	1	Spring Release Coil - 250 V-dc
6	5	All	All	006174582	G-010	006174582	G-010	1	Spring Release Coil - 115 V-ac
6	5	All	All	006174582	G-014	006174582	G-014	1	Spring Release Coil - 230 V-ac
6	5	All	All	006275070	G-002	006275070	G-002	1	Spring Release Coil - 48 V-dc
6	10	All	All	0456A0866	P-005	0456A0866	P-005	5	Switch, Normally Open
6	10	All	All	0456A0866	P-006	0456A0866	P-006	1	Switch, Normally Closed
11	9	All	All	0137A9192	G-003	0137A9192	G-003	1	Auxiliary Switch
6	16	All	All	0161A4231	P-001	0161A4231	P-001	1	Closing Latch Spring
11	13	All	All	0137A9252	P-001	0137A9252	P-001	1	Prop Spring
4	5	All	All	0161A4241	P-001	0161A4241	P-001	1	Driving Pawl Spring
3	1	All	All	0161A5909	P-001	0161A5909	P-001	*2	Latching Pawl Spring

Quantities (2) relays required on special control circuits. Check breaker and connection diagram.

\* Furnish 0161A4241 P-001 for breakers not having closing spring discharge mechanism.

\*\* All except breakers with "B" in suffix.

[www.ElectricalPartManuals.com](http://www.ElectricalPartManuals.com)

Fig. 2 8034471

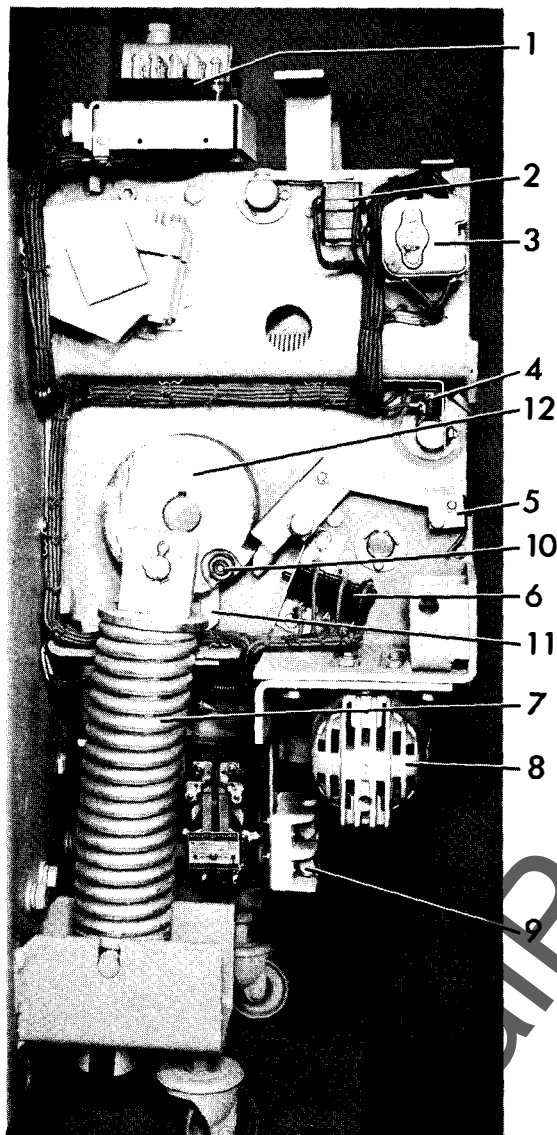

Fig. 1 8034473

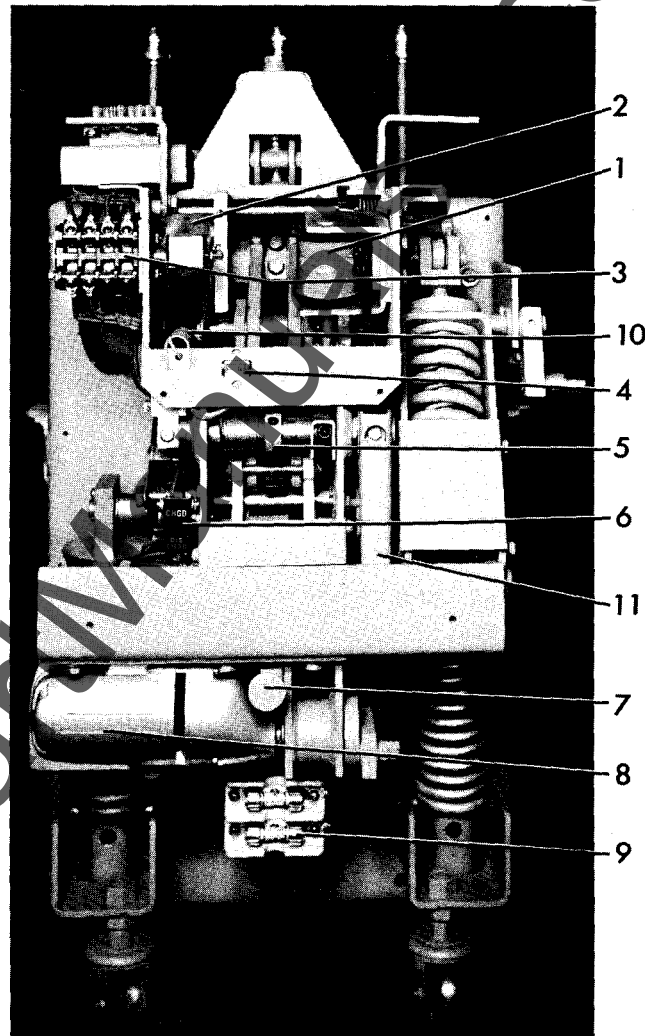

Fig. 1 Left Side View ML-13  
Operating Mechanism

Fig. 2 Front View ML-13  
Operating Mechanism

- 1. Secondary Coupler
- 2. Interlock Switches
- 3. Auxiliary Switch
- 4. Latch Checking Switch
- 5. Charge-Discharge Indicator
- 6. Power Switches
- 7. Closing Springs
- 8. Motor
- 9. Fuses
- 10. Closing Latch Roller
- 11. Closing Latch
- 12. Switch Cam

- 1. Trip Coil
- 2. Open - Close Indicator
- 3. Auxiliary Switch
- 4. Counter
- 5. Trip Latch
- 6. Charge-Discharge Indicator
- 7. Close Button
- 8. Motor
- 9. Fuse
- 10. Prop Spring
- 11. Trip Lever



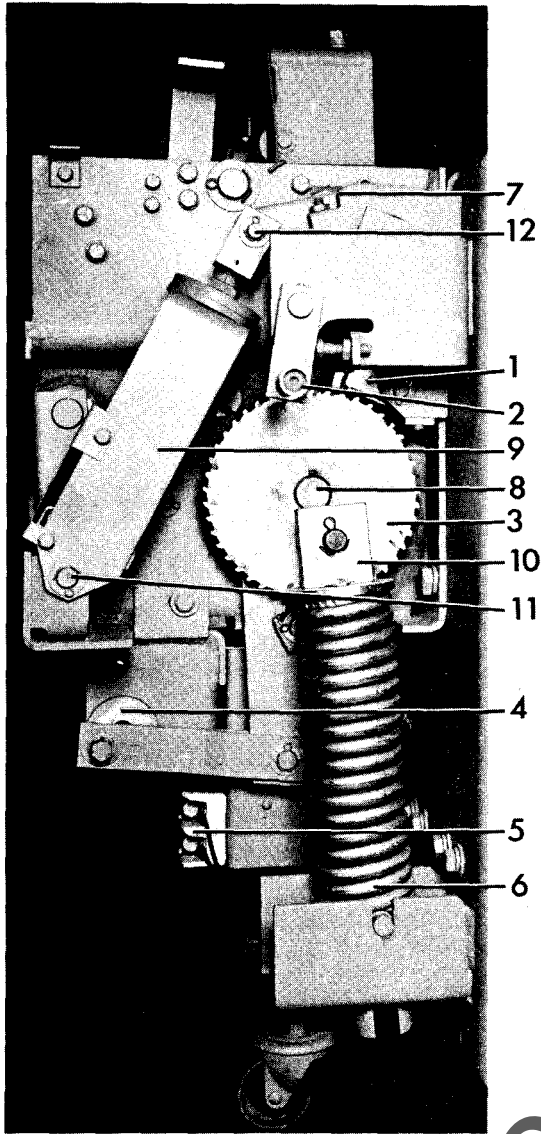

Fig. 3 Right Side View ML-13 Operating Mechanism

1. Latching Pawls
2. Positive Interlock Roller
3. Ratchet Wheel
4. Eccentric
5. Fuse
6. Closing Spring
7. Main Shaft Bearing
8. Cam Shaft
9. Opening Spring
10. Guide Block
11. Lower Spring Pin
12. Upper Spring Pin

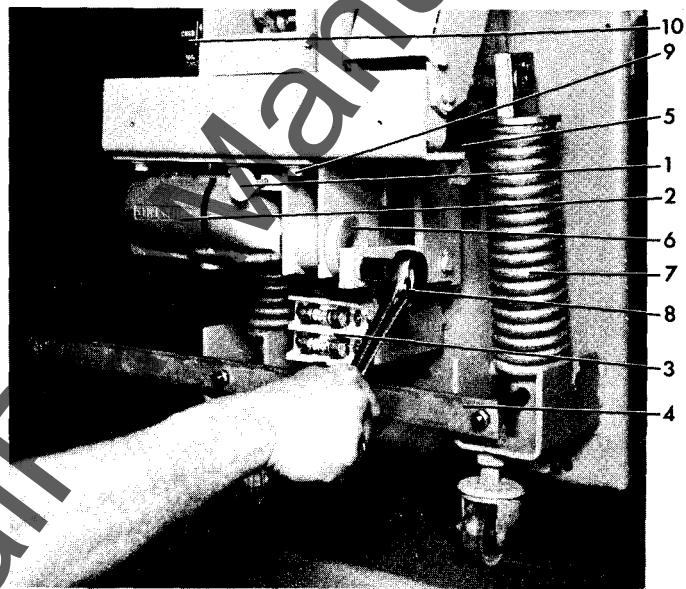

Fig. 4 Spring Blocking Device

1. Close Button
2. Motor
3. Fuse
4. Spring Blocking Device
5. Driving Pawl
6. Eccentric
7. Closing Spring
8. Manual Charging Wrench
9. Support Bolts
10. Charge-Discharge Indicator

FIG. 4 8034475

FIG. 3 8034463

11405320

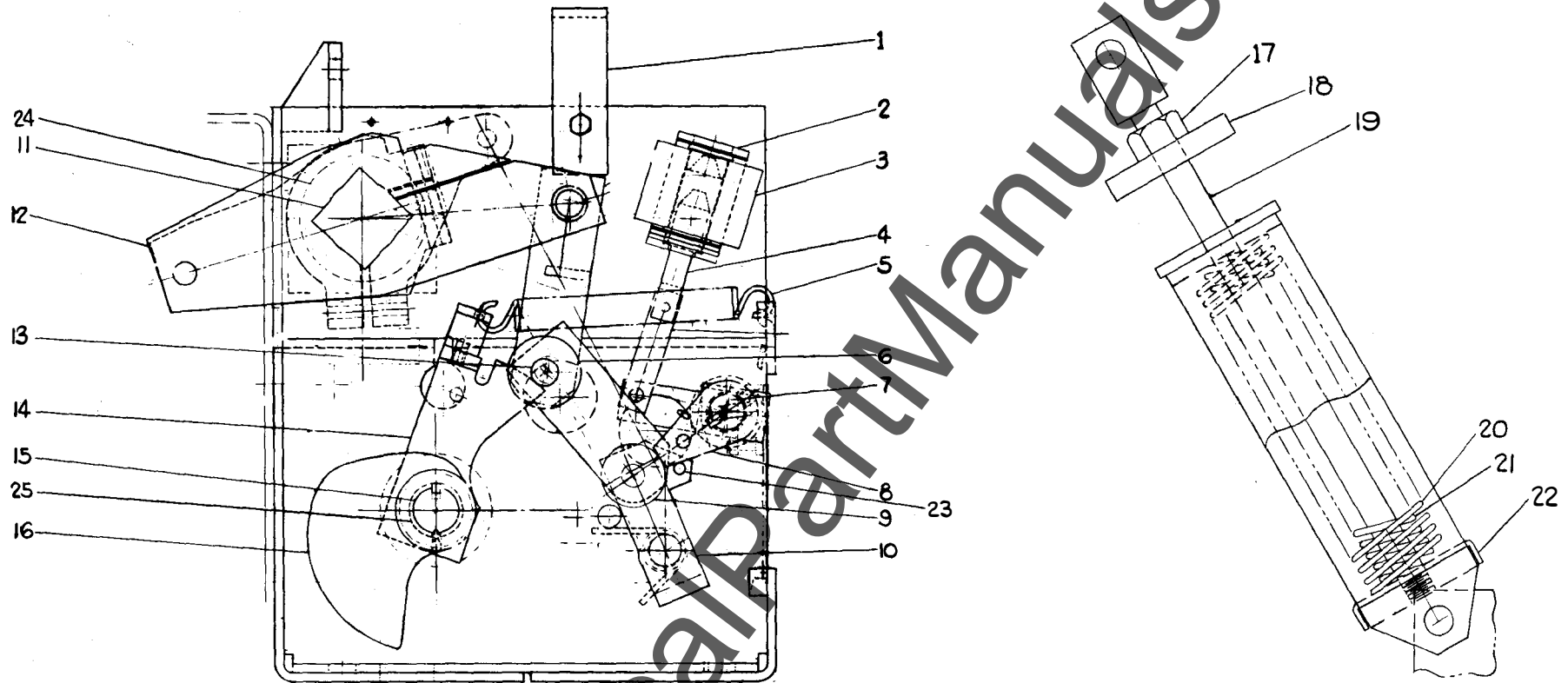
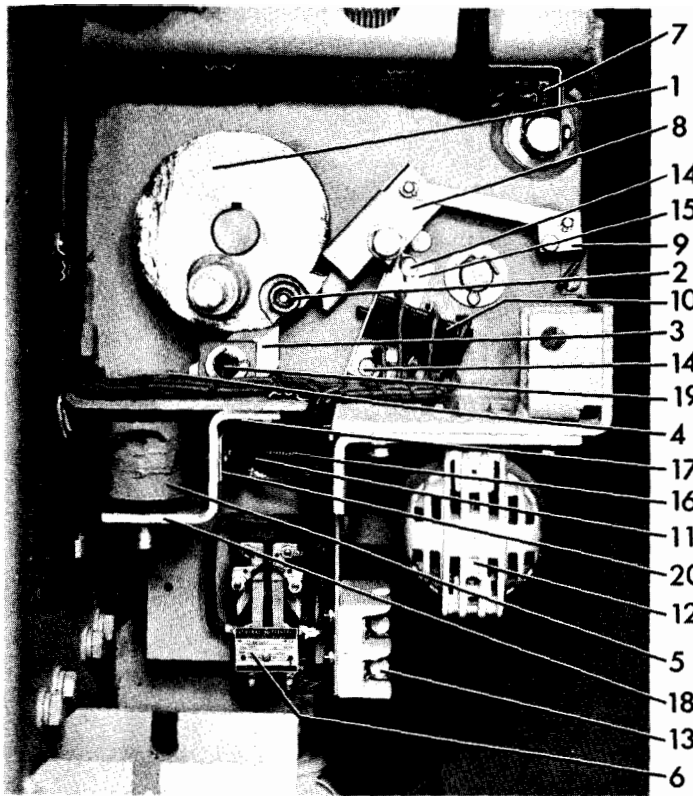

Fig. 5 Sectional Side View of Mechanism

Opening Spring

- |                        |                               |                        |
|------------------------|-------------------------------|------------------------|
| 1. Handle              | 10. Trip Latch Roller Support | 18. Stop Plate         |
| 2. Trip Coil Support   | 11. Crank Shaft               | 19. Spring Rod         |
| 3. Trip Coil           | 12. Cranks                    | 20. Spring             |
| 4. Trip Armature       | 13. Prop Pin                  | 21. Spring             |
| 5. Prop Reset Spring   | 14. Prop                      | 22. Guide              |
| 6. Cam Follower Roller | 15. Drive Shaft               | 23. Stop Pin           |
| 7. Trip Shaft          | 16. Cam                       | 24. Main Shaft Bearing |
| 8. Trip Latch          | 17. Check Nut                 | 25. Cam Shaft Bearing  |
| 9. Trip Latch Roller   |                               |                        |



1. Switch Cam
2. Closing Latch Roller
3. Closing Latch
4. Latch Adjusting Screw
5. Spring Release Solenoid
6. Control Relay
7. Latch Checking Switch
8. Switch Striker
9. Charge-Discharge Indicator
10. Power Switches
11. Latch Monitoring Switch
12. Motor
13. Fuse
14. Switch Support Bolts
15. Switch Support
16. Closing Latch Spring
17. Release Coil Bolts
18. Release Coil Support
19. Closing Latch Shaft
20. Switch Mounting Bracket

Fig. 6 Control Mechanism

Fig. 6 8034467

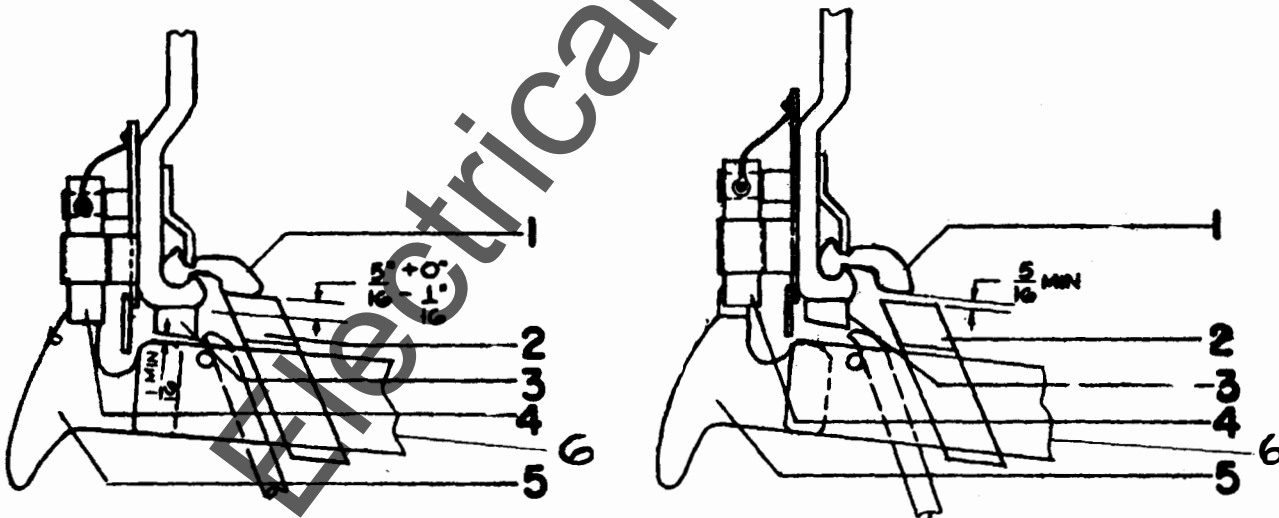

Primary Contact Wipe

Arcing Contact Wipe

Fig. 8 Contact Adjustments

- |                                |                               |
|--------------------------------|-------------------------------|
| 1. Stationary Primary Contacts | 4. Stationary Arcing Contacts |
| 2. Movable Primary Contacts    | 5. Movable Arcing Contacts    |
| 3. Buffer Block                | 6. Contact Arm                |

Fig. 8 114C5320

Fig. 7 258C689

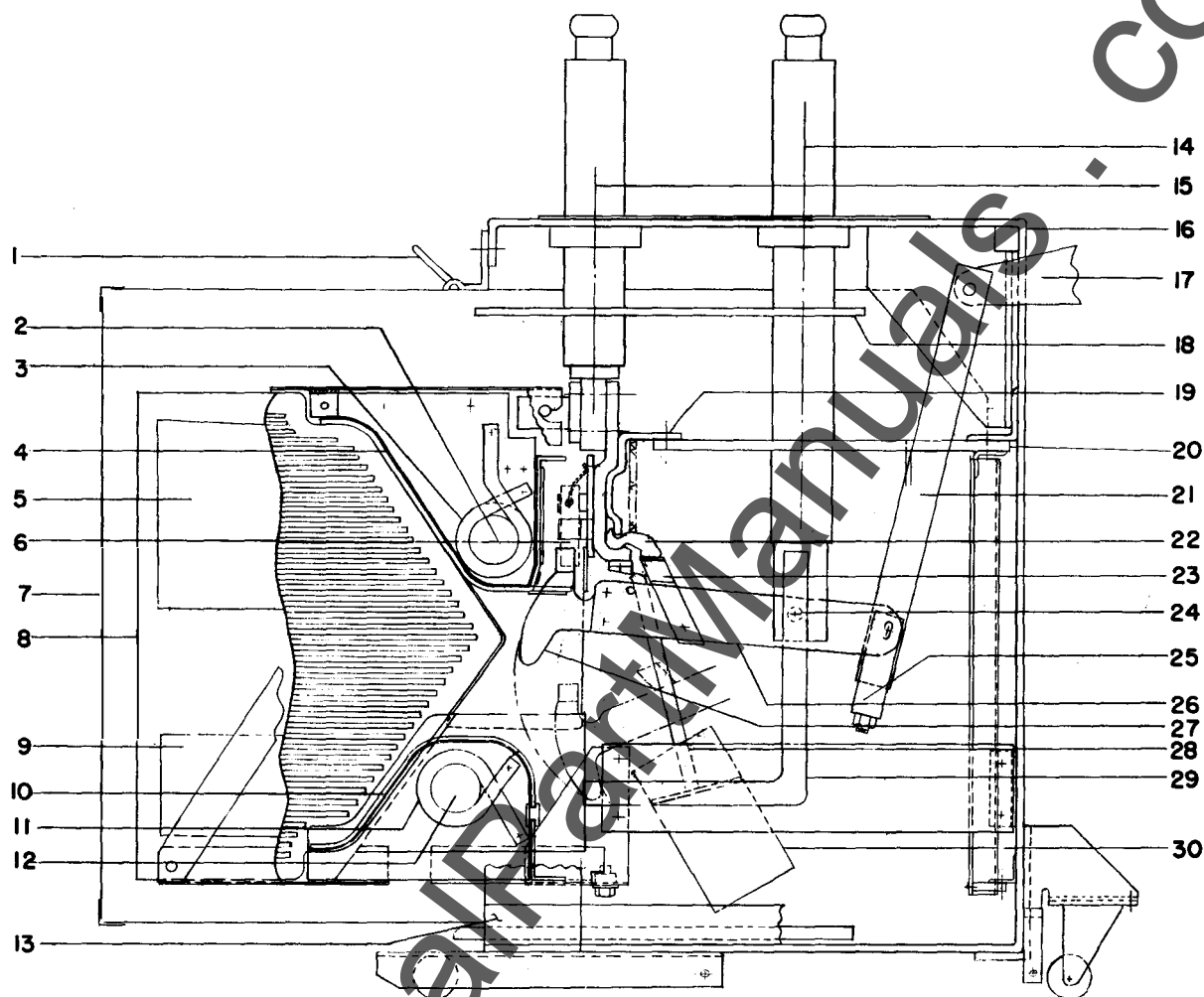

Fig. 7 Cross Section of Breaker Pole Unit

- |                              |                                  |
|------------------------------|----------------------------------|
| 1. Box Barrier Handle        | 16. Frame                        |
| 2. Blow-out Core             | 17. Operating Crank              |
| 3. Blow-out Coil             | 18. Upper Horizontal Barrier     |
| 4. Arc Runner                | 19. Spring Retainer              |
| 5. Pole Piece                | 20. Lower Horizontal Barrier     |
| 6. Stationary Arcing Contact | 21. Operating Rod                |
| 7. Box Barrier               | 22. Stationary Primary Contacts  |
| 8. Arc Chute                 | 23. Movable Primary Contacts     |
| 9. Pole Piece                | 24. Cup Bearing                  |
| 10. Arc Runner               | 25. Yoke                         |
| 11. Blow-out Coil            | 26. Movable Contact Arm Assembly |
| 12. Blow-out Core            | 27. Movable Arcing Contact       |
| 13. Lower Barrier            | 28. Booster Tube                 |
| 14. Front Bushings           | 29. Connection Bar               |
| 15. Rear Bushings            | 30. Booster Cylinder and Piston  |

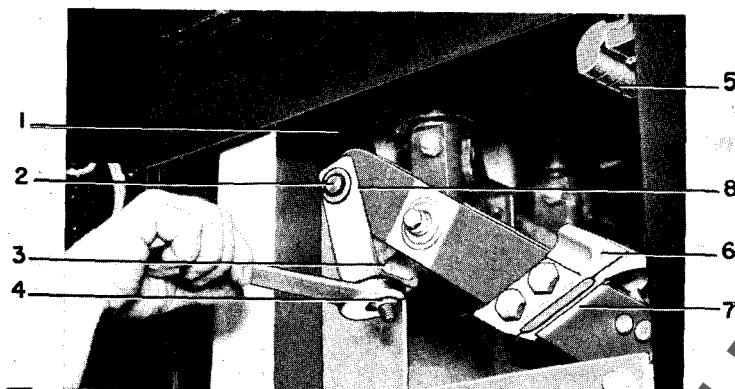

Fig. 9 Adjustable Coupling for Making Primary Contact Wipe Adjustments

- |                      |                                |
|----------------------|--------------------------------|
| 1. Operating Rod     | 5. Stationary Primary Contacts |
| 2. Operating Rod Pin | 6. Movable Primary Contacts    |
| 3. Adjusting Nut     | 7. Contact Arm                 |
| 4. Check Nut         | 8. Yoke                        |

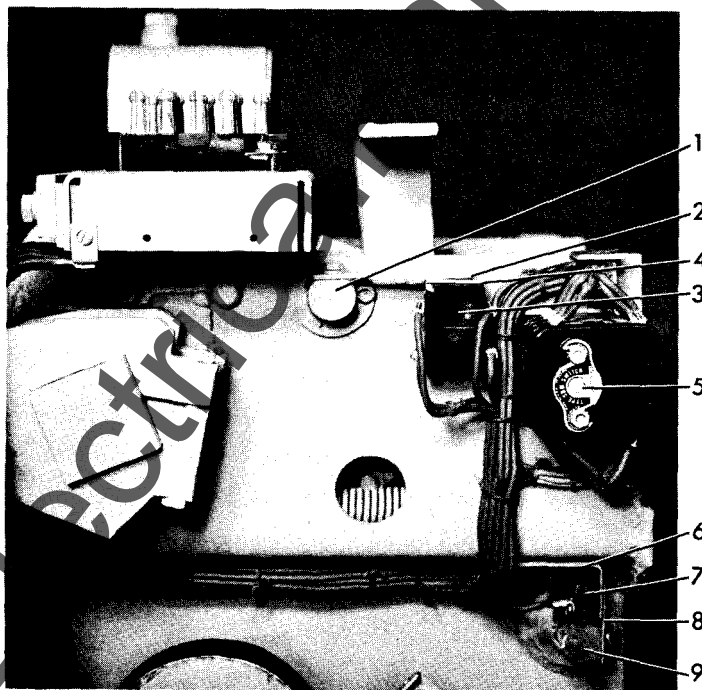

Fig. 10 Positive Interlock Switch

- |                             |                          |
|-----------------------------|--------------------------|
| 1. Positive Interlock Shaft | 6. Switch Support        |
| 2. Switch Arm               | 7. Latch Checking Switch |
| 3. Interlock Switch         | 8. Switch Arm            |
| 4. Switch Support           | 9. Trip Shaft            |
| 5. Auxiliary Switch         |                          |

Fig. 9 8018500

Fig. 10 8034474

Fig. 11 8034470

1. Trip Coil Support
2. Trip Coil
3. Mounting Bolts
4. Counter
5. Trip Latch
6. Trip Arm Screw
7. Manual Trip Lever
8. Open-Close Indicator
9. Auxiliary Switch
10. Switch Arm
11. Latch Set Screw
12. Cotter Pin
13. Prop Spring

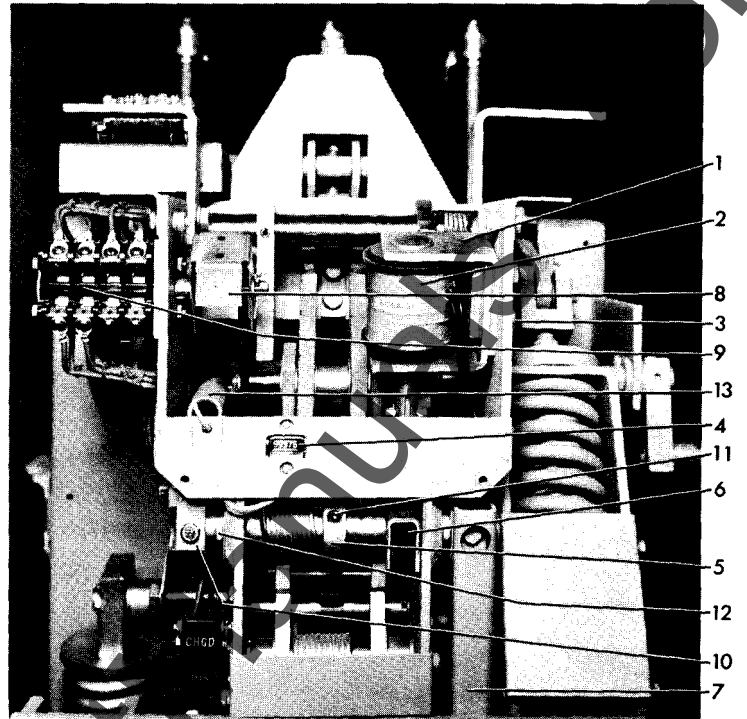

Fig. 11 Auxiliary Switch and Trip Coil

Fig. 12 114C5320

1. Switch Support
2. Latch Checking Switch
3. Switch Arm
4. Trip Latch
5. Reset Pin Stop
6. Latch Roller
7. Latch Roller Link
8. Latch Roller Pin

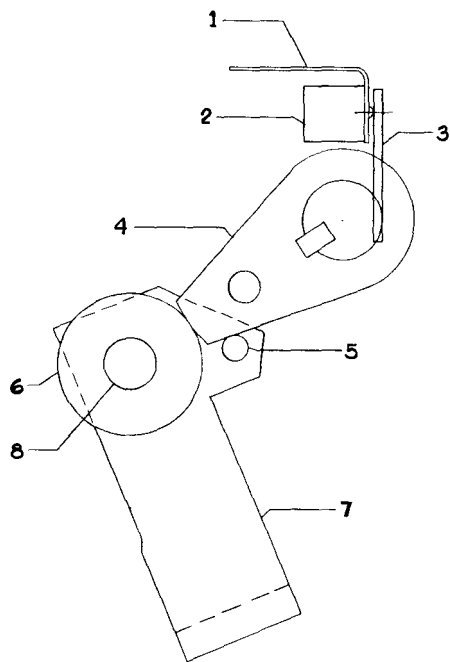
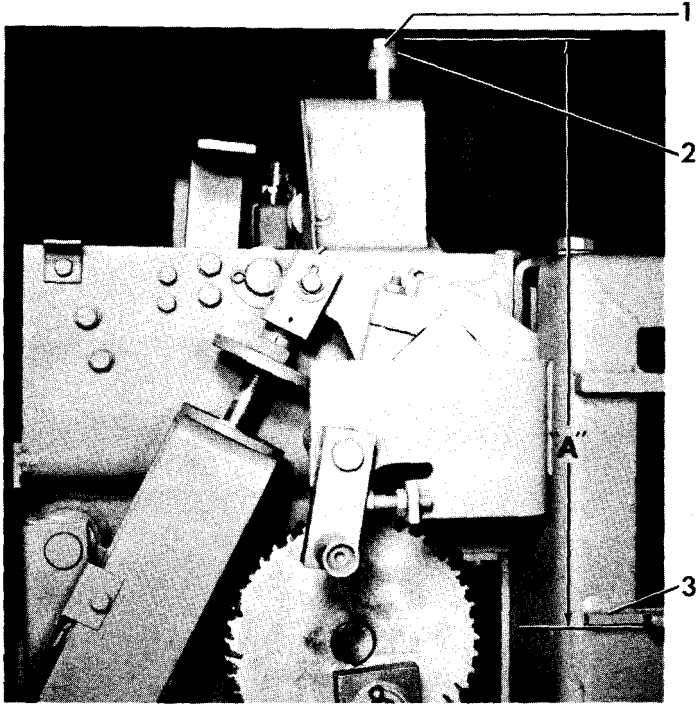
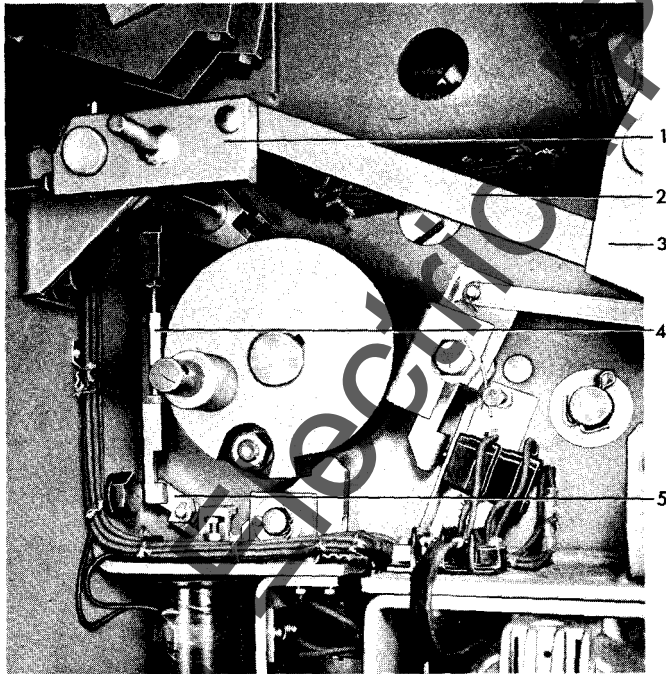

Fig. 12 Latch Checking Switch



- 1. Plunger Bolt
- 2. Washer
- 3. Breaker Lifting Rail

Fig. 13 Plunger Interlock



- 1. Actuating Crank
- 2. Link
- 3. Tripping Crank
- 4. Turnbuckle
- 5. Spring Release Crank

Fig. 14 Spring Release Interlock

Fig. 13 8034464

Fig. 14 8036489

Fig. 15 8034471

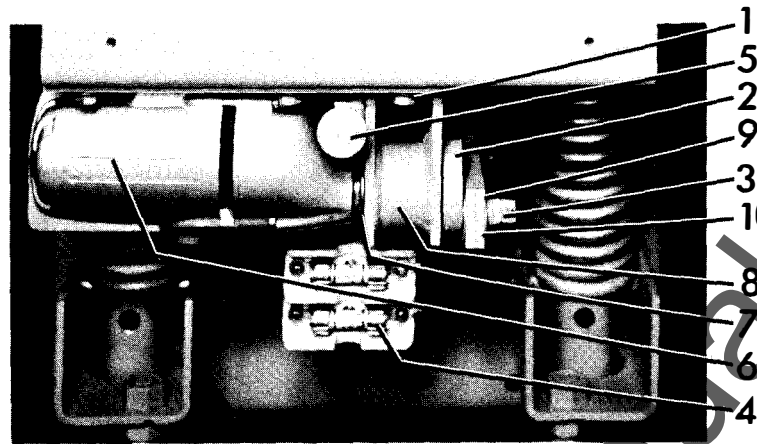
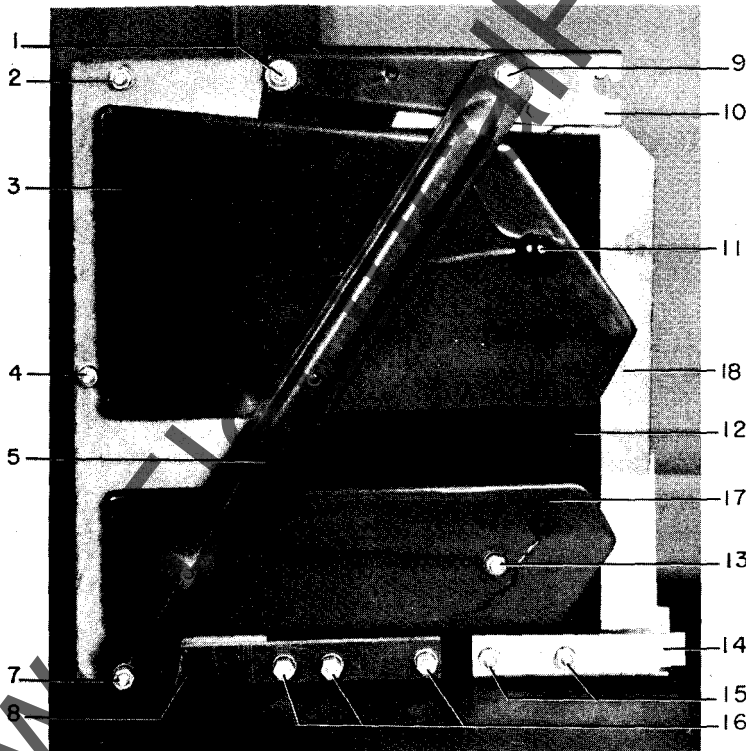

Fig. 15 Driving Elements

- |                        |                   |
|------------------------|-------------------|
| 1. Mounting Bolts      | 6. Motor          |
| 2. Eccentric           | 7. Retaining Ring |
| 3. Hex Charging Stud   | 8. Motor Support  |
| 4. Fuse                | 9. Retaining Ring |
| 5. Manual Close Button | 10. Driving Link  |

Fig. 16 8025741



- |                               |
|-------------------------------|
| 1. Assembly Bolts and Bushing |
| 2. Assembly Bolts             |
| 3. Upper Pole Piece           |
| 4. Assembly Bolt              |
| 5. Side Brace                 |
| 7. Assembly Bolt              |
| 8. Lower Brace                |
| 9. Assembly Bolt              |
| 10. Upper Mounting Support    |
| 11. Insulating Cap            |
| 12. Side Shield               |
| 13. Assembly Bolt             |
| 14. Lower Mounting Support    |
| 15. Assembly Bolts            |
| 16. Assembly Bolts            |
| 17. Lower Pole Piece          |
| 18. Upper Insulation          |

Fig. 16 Arc Chute Assembly



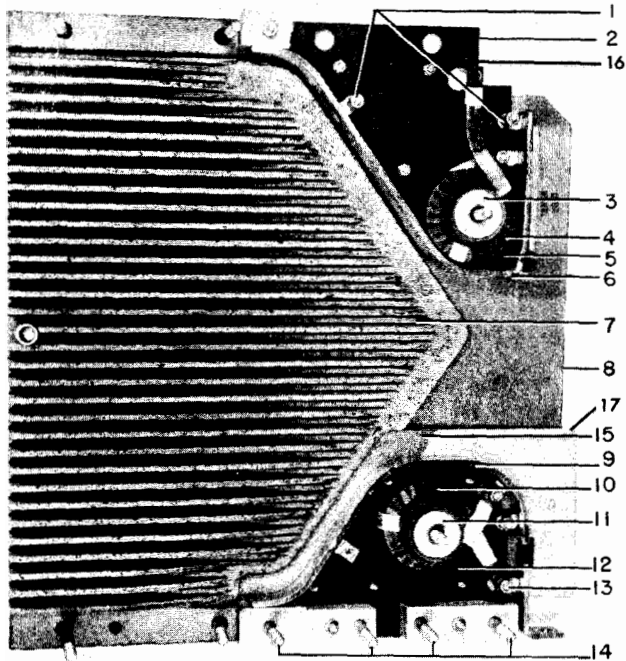

1. Upper Arc Runner Spacers
2. Upper Arc Runner Assembly
3. Blowout Core
4. Blowout Coil
5. Insulation
6. Upper Arc Runner
7. Arc Chute Side
8. Upper Insulation
9. Lower Arc Runner
10. Blowout Coil
11. Blowout Core
12. Lower Arc Runner Assembly
13. Lower Coil Connection
14. Lower Arc Runner Spacers
15. Lower Shield
16. Upper Insulation
17. Lower Insulation

Fig. 17 Arc Chute Assembly with Side Removed

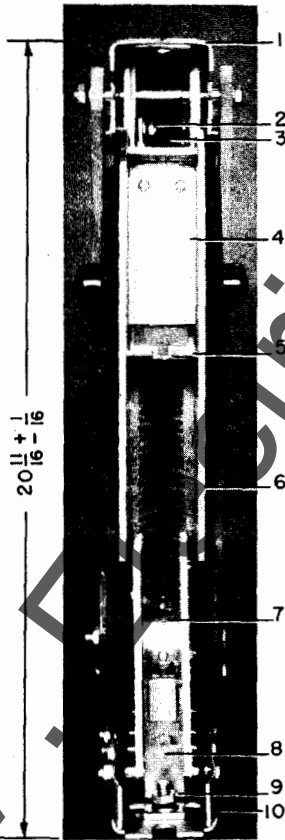

1. Upper Mounting Support
2. Connection Bolt
3. Upper Blowout Coil
4. Upper Arc Runner Assembly
5. Upper Arc Runner
6. Side Shield
7. Lower Arc Runner Assembly
8. Lower Coil Connection
9. Connection Nut
10. Lower Mounting Support

Fig. 18 Front View Arc Chute Assembly

Fig. 17 8024600

Fig. 18 8024605

WWW.ElectricalPartMaterials.com

Fig. 19 8019971

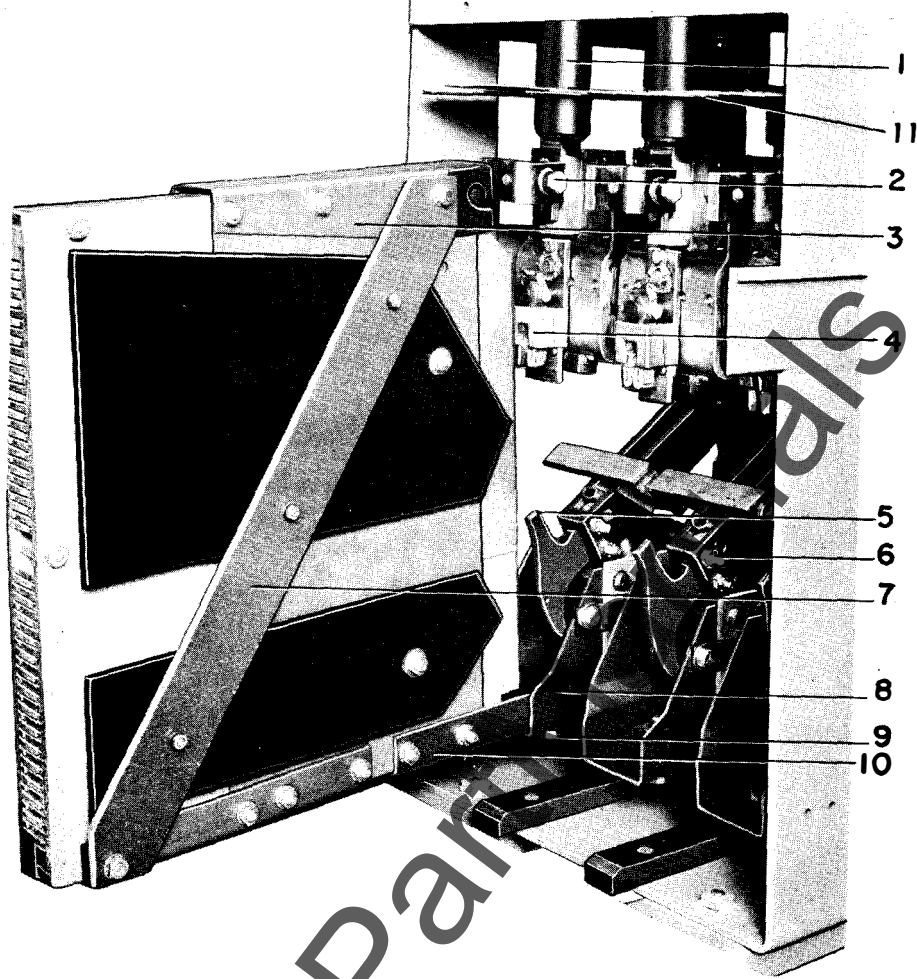

Fig. 19 Arc Chute Partially Removed Showing Accessibility of Arcing Contacts

- |                                       |                               |
|---------------------------------------|-------------------------------|
| 1. Rear Bushing                       | 6. Assembly Bolts             |
| 2. Supporting Bolt                    | 7. Brace for Arc Chute        |
| 3. Upper Mounting Support             | 8. Arc Chute Mounting Bracket |
| 4. Stationary Arcing Contact Assembly | 9. Lower Supporting Bolt      |
| 5. Movable Arcing Contact             | 10. Lower Mounting Support    |
|                                       | 11. Upper Horizontal Barriers |

Fig. 21 8029373

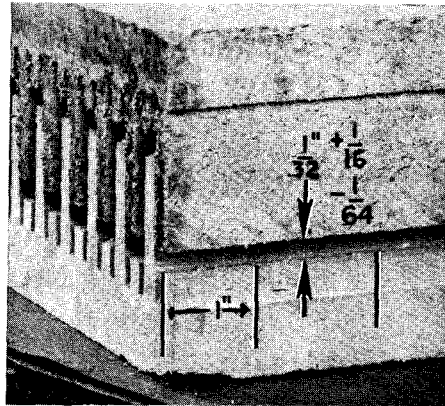
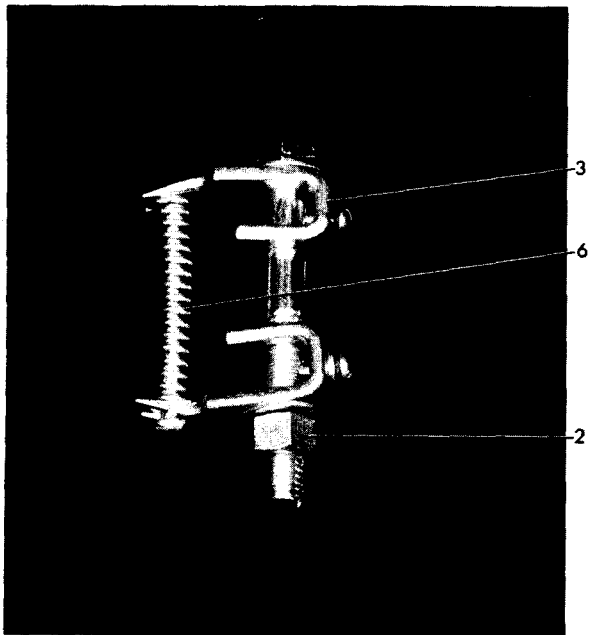

Fig. 21 Arc Chute Fin Spacing

PART	LUBRICATION AT MAINTENANCE PERIOD	ALTERNATE LUBRICATION (REQUIRES DISASSEMBLY)
Sleeve Bearings - links, trip shaft, etc. (Teflon coated bearings)	No lubrication required.	No lubrication required.
Sleeve Bearings - main crank shaft, driving pawl lever. (Bronze or cast iron)	Light application of machine oil SAE 20 or SAE 30.	Remove bearings or links, clean per instructions and apply D50H15 lubricant liberally.
Contact Arm Hinge Assembly Cup bearing Loose rings between bushing and contact arm.	No lubrication required.	Wipe clean and apply D50H47.
Roller and Needle Bearings	Light application of machine oil SAE 20 or SAE 30.	Clean per instructions and repack with D50H15 lubricant.
Ground surfaces such as cams, ratchet teeth, etc. (Surfaces coated with $MoS_2$ )	No lubrication required.	No lubrication required.
Ground surfaces such as latches, rollers, prop, etc.	Wipe clean and apply D50H15 lubricant.	Wipe clean and apply D50H15 lubricant.
Silver plated contacts and primary disconnect studs.	Wipe clean and apply D50H47.	Wipe clean and apply D50H47.
Booster Cylinder	Do not Lubricate.	Do not lubricate.
Arcing Contacts	Do not Lubricate.	Do not lubricate.

Fig. 20 LUBRICATION CHART

Fig. 23D 8034468



A

Fig. 23C 8034469

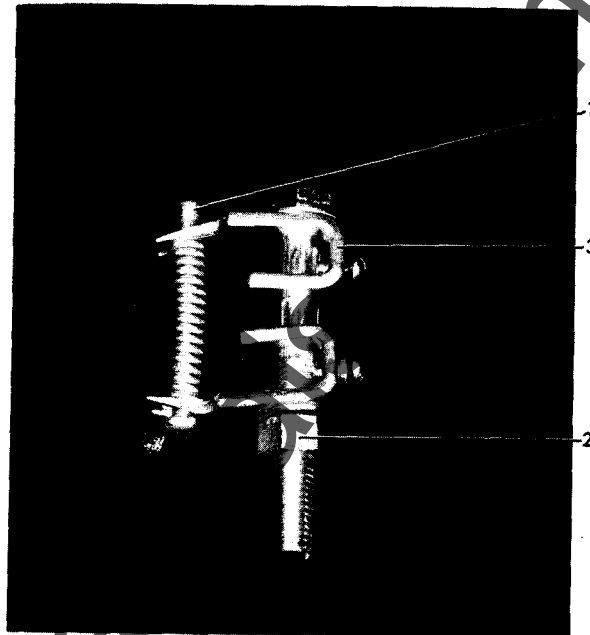

B

Fig. 23B 8034465

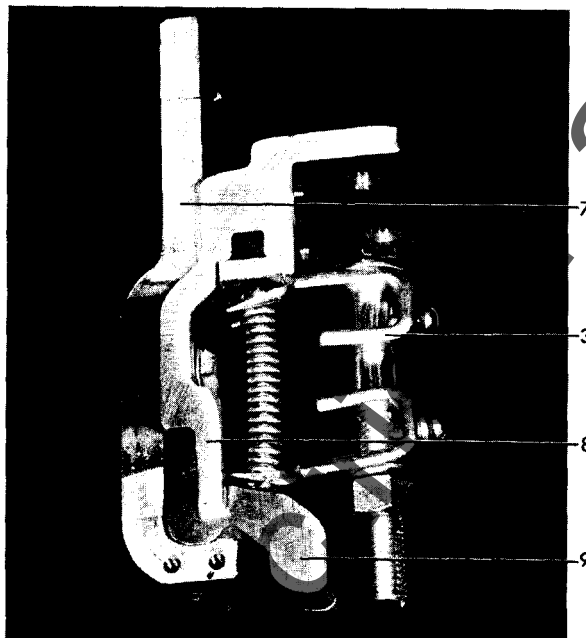

C

Fig. 23A 8034466

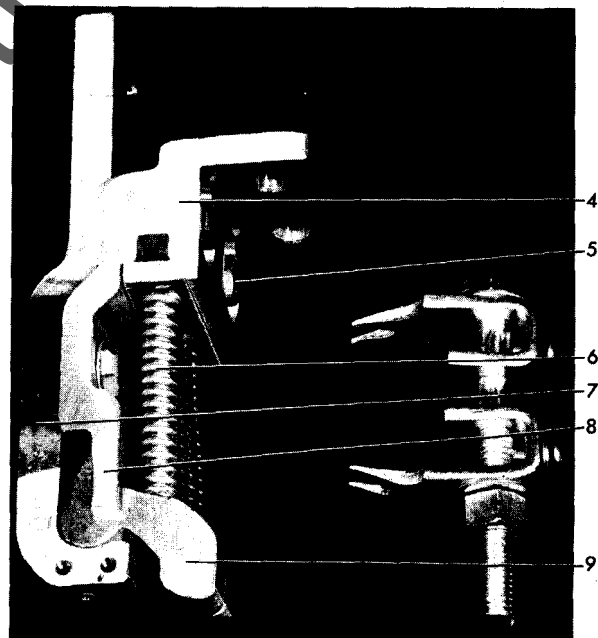

D

Fig. 23 Method of Installing Primary Contact Springs Using a Spring Compressor

- |                      |                              |
|----------------------|------------------------------|
| 1. Spring Guide      | 6. Spring                    |
| 2. Compressor Nut    | 7. Contact Support           |
| 3. Spring Compressor | 8. Stop Plate                |
| 4. Spring Retainer   | 9. Stationary Primary Finger |

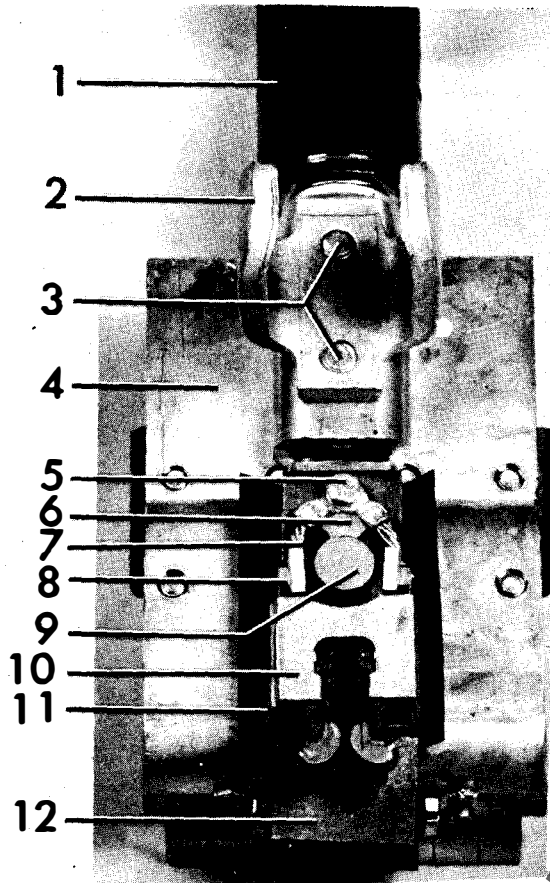

Fig. 22 Rear Bushing Assembly

1. Rear Bushing
2. Guide and Support for Arc Chute
3. Bolts for Contact Support
4. Contact Support
5. Bolt for Flexible Braid
6. Mounting Bolt
7. Flexible Braid
8. Connection Bolt
9. Stud for Mounting Arcing Fingers
10. Stationary Arcing Contact Assembly
11. Spring Baffle
12. Insulating Plate

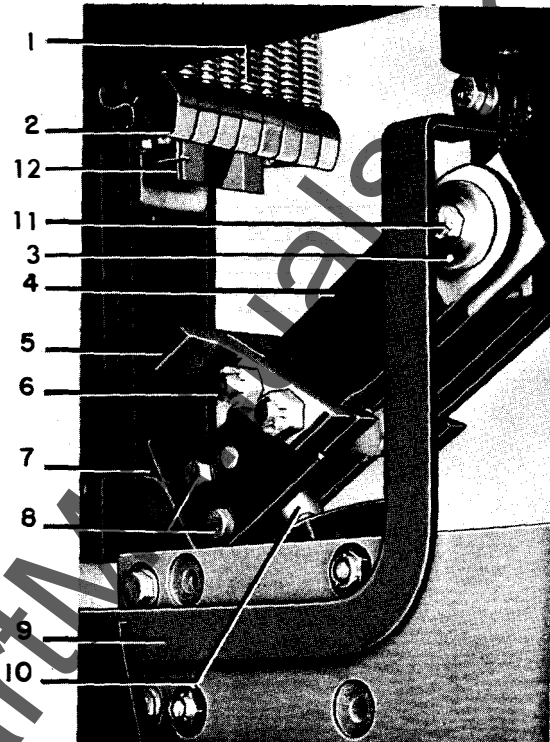

Fig. 24 Removal of Contacts

1. Contact Springs
2. Stationary Primary Contacts
3. Cup Bearing
4. Contact Arm
5. Movable Primary Contacts
6. Assembly Bolts
7. Movable Arcing Contact
8. Assembly Bolts
9. Connection Bar
10. Piston Assembly
11. Hinge Pin
12. Buffer

Fig. 24 8012188

Fig. 22 8025170

[www.ElectricalPartManuals.com](http://www.ElectricalPartManuals.com)

**GENERAL ELECTRIC SALES OFFICES**

GEZ-2500L

READY TO ASSIST YOU . . . When You Have Electrical Problems . . . Need Further Information . . . Require Ordering Instructions

**SALES OFFICE CODE KEY**  
 \* Industrial Equipment (including Agent and Distributor) Sales  
 † Electric Utility Equipment Sales  
 ‡ Marine and Defense Equipment Sales  
 † Component Sales Operation

State	City	Address	City	Address	
ALABAMA	Birmingham	35205 2151 Highland Ave.	OKLAHOMA	Oklahoma City	73106 2000 Classen Blvd. Tulsa 74114 Columbia Bldg., 2651 E. 21st St.
	Mobile	36602 704 Government St.		OREGON	Eugene
ARIZONA	Phoenix	85012 3550 N. Central Ave.	PENNSYLVANIA		Allentown
	Tucson	85711 151 S. Tucson Blvd.		SOUTH CAROLINA	Columbia
ARKANSAS	North Little Rock	72114 1900 E. Washington Pine Bluff 71602 P. O. Box 1033	TENNESSEE		Chattanooga
	CALIFORNIA	Fresno		93728 1532 N. West Ave.	TEXAS
Los Angeles		90054 212 N. Vignes St.	UTAH	Salt Lake City	
Los Angeles	90005 3325 Wilshire Blvd.	VERMONT		Rutland	381/2 Center St.
Oakland	94612 409 Thirteenth St.		VIRGINIA	Newport News	23601 P.O. Box 1038, 311 Main St. Richmond 23230 5001 W. Broad St. Roanoke 24005 920 S. Jefferson St.
Redwood City	94063 55 Veterans Blvd.	WASHINGTON		Pasco	99301 824 W. Lewis St. Seattle 98104 710 Second Ave. Spokane 99220 S. 162 Post St. Spokane 99220 E. 1805 Trent St.
Sacramento	95816 2407 "J" St.		WEST VIRGINIA	Charleston	25328 306 MacCorkle Ave., S.E. Fairmont 26555 310 Jacobs Bldg. Wheeling 40 Fourteenth St.
San Diego	92103 2560 First Ave.	WISCONSIN		Appleton	54910 510 W. College Ave. Madison 53703 340 W. Washington Ave. Milwaukee 53233 940 W. St. Paul Ave.
San Francisco	94106 235 Montgomery St. San Jose 95128 2155 So. First St.		CANADA	Canadian General Electric Company, Ltd., Toronto	
COLORADO	Denver	80201 201 University Blvd.		HAWAII	American Factors, Ltd., P.O. Box 3230, Honolulu 96801
	CONNECTICUT	Hamden	06518 2905-2921 Dixwell Ave.		NEW JERSEY
Hartford		06105 764 Asylum Ave.	NEW MEXICO	Albuquerque	
DISTRICT OF COLUMBIA	Washington	20005 777-14th St., N.W.		NEW YORK	Albany
	FLORIDA	Cocoa Beach (Cape Canaveral Office)	1325 N. Atlantic Ave. Coral Gables 33146 250 Bird Road Jacksonville 32202 1901 Hill St. Miami 33134 4100 West Flagler St. Pensacola 32503 First Bank Bldg. Tampa 33609 Henderson Blvd. at Lois Ave. Tampa 33609 2106 S. Lois Ave.		NEW HAMPSHIRE
GEORGIA		Atlanta	30309 1860 Peachtree Rd., N.W. Macon 31202 682 Cherry St. Savannah 31405 5002 Paulsen St.	NEW JERSEY	
	IDAHO	Boise	83706 1524 Idaho St.		NORTH CAROLINA
ILLINOIS		Chicago	60680 840 S. Canal St. Peoria 61603 2008 N.E. Perry Ave. Rockford 61105 4223 East State St. Springfield 62701 607 E. Adams St.	NORTH DAKOTA	
	INDIANA	Evansville	47714 2709 Washington Ave. Fort Wayne 46807 1635 Broadway Fort Wayne 46806 3606 S. Calhoun St. Indianapolis 46207 3750 N. Meridian St. South Bend 46601 430 N. Michigan St.		OHIO
IOWA		Cedar Rapids	52401 210 Second St., S.E. Davenport 52805 1039 State St., Bettendorf, Iowa Des Moines 50310 3839 Merle Hay Rd. Sioux City 51101 520 Pierce St.	PENNSYLVANIA	
	KANSAS	Wichita	67211 820 E. Indianapolis Ave.		TEXAS
KENTUCKY		Lexington	40503 465 E. High St. Louisville 40218 2300 Meadow Dr.	UTAH	

**GENERAL ELECTRIC SERVICE SHOPS**

WHEN YOU NEED SERVICE . . . These G-E service shops will repair, recondition, and rebuild your electric apparatus. The facilities are available day and night, seven days a week, for work in the shops or on your premises. Latest factory methods and genuine G-E renewal parts are used to maintain peak performance of your equipment. For full information about these services, contact your nearest service shop or sales office.

State	City	Address	City	Address	
ALABAMA	Birmingham	35211, P.O. Box 3687 7-18th St., S.W.	KANSAS	(Strother) Arkansas City	797 P.O. Box 3687
	ARIZONA	(Phoenix) Glendale		85301 4911 West Colter St.	KENTUCKY
CALIFORNIA		Los Angeles	90001 6900 Stanford Ave. (Los Angeles) Ontario International Airport	LOUISIANA	
	Oakland	94608 3400 Wood St. Sacramento 95814 99 North 17th St. San Francisco 94103 1098 Harrison St.	MARYLAND		Baltimore
COLORADO	Denver	80205 3353 Larimer St.		MASSACHUSETTS	(Boston) Medford
	CONNECTICUT	(Southington) Plantsville	06479 370 Atwater St.		MICHIGAN
FLORIDA		Jacksonville	32203 P.O. Box 2932, 2020 W. Beaver St. (Miami) Hialeah 33010 1062 E. 28th St. Tampa 33601 P.O. Box 1245	MINNESOTA	
	GEORGIA	(Atlanta) Chamblee	30005 5035 Peachtree Industrial Blvd.		MISSOURI
ILLINOIS		Chicago	60632 4360 W. 47th St.	NEW YORK	
	INDIANA	Ft. Wayne	46803 1731 Edsall Ave. Indianapolis 46222 1740 W. Vermont St.		NORTH CAROLINA
IOWA		(Davenport) Bettendorf	52722 1025 State St.	OHIO	
	KANSAS	Columbus	43223 P.O. Box 6198, 2128 Eakin Rd. Toledo 43605 405 Dearborn Ave. Youngstown 44507 272 E. Indianola Ave.		OREGON
CALIFORNIA		Los Angeles	90001 6900 Stanford Ave. (Los Angeles) Ontario International Airport	PENNSYLVANIA	
	COLORADO	Denver	80205 3353 Larimer St.		TEXAS
CONNECTICUT		(Southington) Plantsville	06479 370 Atwater St.	UTAH	
	FLORIDA	Jacksonville	32203 P.O. Box 2932, 2020 W. Beaver St. (Miami) Hialeah 33010 1062 E. 28th St. Tampa 33601 P.O. Box 1245		VIRGINIA
GEORGIA		(Atlanta) Chamblee	30005 5035 Peachtree Industrial Blvd.	WASHINGTON	
	ILLINOIS	Chicago	60632 4360 W. 47th St.		WEST VIRGINIA
INDIANA		Ft. Wayne	46803 1731 Edsall Ave. Indianapolis 46222 1740 W. Vermont St.	WISCONSIN	
	IOWA	(Davenport) Bettendorf	52722 1025 State St.		