



OPERATION MANUAL

OPTI-FIT SUPPLIED AIR SYSTEMS



9800-35

ONE-MAN FULLFACE SYSTEM - 1/4 HP

9800-25

TWO-MAN FULLFACE SYSTEM - 3/4 HP

9800-45

FOUR-MAN FULLFACE SYSTEM - 1 1/2 HP

*READ AND UNDERSTAND ALL INSTRUCTIONS BEFORE USING THESE PRODUCTS.
WORKERS WHO HAVE BECOME SENSITIZED TO ISOCYANATES SHOULD NOT WORK
WITH OR AROUND ISOCYANATES.*

CUSTOMER ACCEPTANCE AND WARRANTY POLICY

I, the undersigned purchaser (may be signed by either owner or shop manager) of an SAS Safety Corp Supplied-Air System or pump, agree that I have thoroughly read and understand the Instruction Manual for the safe operation of the air-supply system. By signing and returning this acceptance form, I acknowledge that I did not try and operate the system before studying the manual, and further agree to continue to follow the recommended guidelines for safe operation per OSHA 29CFR 1910.134. I also know that I can telephone SAS at any time, with any questions concerning the Safe operation of the air supply system. **I further agree that there will be no warranty adjustments by SAS until I return this signed acceptance to them at:**

3031 Gardenia Avenue, Long Beach CA 90807 (800) 262-0200 FAX (800) 244-1938.

NAME and TITLE

ACCOUNT NAME

ADDRESS

CITY

STATE

ZIP CODE

TELEPHONE

GAST MODEL #

SAS SERIAL #

DATE CODE

SUPPLIER or SALESMAN

DATE OF DELIVERY AND INVOICE #

RECEIVED BY SAS

MUST BE RETURNED TO SAS SAFETY CORP. TO INITIATE WARRANTY!



SUPPLIED-AIR RESPIRATOR

WARNING

- This respirator system reduces, but does not eliminate, exposure and inhalation of contaminants, it DOES NOT provide complete protection.
- If you are sensitized to paint, paint hardeners, isocyanates, epoxy, metal cutting fluid, latex, or any other material, this respirator system WILL NOT protect you.
- If you have ever had breathing problems while or after using or being around paint or pain hardeners, isocyanates, epoxy, metal cutting fluids, latex, or any other material. DO NOT USE this respirator system. It WILL NOT protect you.
- Failure to read, understand, and follow ALL warnings and instructions provided here, in the respirator user's manual, and with the materials you are using (paint, epoxy, pesticides, etc.) may cause INJURY, DISEASE, or DEATH.
- If you do not understand the instructions, and warning DO NOT USE this respirator system.
- If these instructions and warning indicate that you should not use this respirator system or that it will not protect you. DO NO USE IT, even if conflicting instructions from somewhere else (your boss or a paint store, for example) indicate you can.
- YOU assume responsibility for any damage, injury, disease, or death caused by YOUR failure to follow instructions and heed warnings.

INDEX

Page

1	GENERAL SAFETY INSTRUCTION DO'S & DON'T
2	GENERAL DESCRIPTION
3	ASSEMBLY INSTRUCTIONS, OIL-LESS AIR PUMP
4	OPERATING INSTRUCTIONS, OIL-LESS AIR PUMP
5	PARTS DESCRIPTION, 9805-00
6	PARTS DESCRIPTION, 9810-00 & 9820-00
7	PARTS DESCRIPTION, 9840-00
8-9	MAINTENANCE, OIL-LESS AIR PUMP
10	TROUBLE SHOOTING
11	CONTROL OF AIR QUALITY
12	PARTS DESCRIPTION, 9814-05 FULLFACE
13-16	USER INSTRUCTIONS, SAR RESPIRATORS
16	SPECTACLE KIT, INSTALLATION INSTRUCTIONS
17-38	OSHA CODE OF FEDERAL REGULATIONS
39	RESPIRATORY PROTECTION PROGRAM
40	OPTI-FIT FULLFACE WARRANTY AND LIMITATION OF LIABILITY
41	GAST OIL-LESS AIR PUMP WARRANTY

IMPORTANT

GENERAL SAFETY INSTRUCTIONS

- DO NOT** use Supplied-Air System in any atmosphere immediately Dangerous to Life or Health (IDLH) and/or from which the worker cannot escape without the use of a respirator.
OSHA 29CFR 1910.134.
- DO NOT** place oil-less air pump in an area that cannot guarantee clean, breathable air, grade D per OSHA 29CFR 1910.134.
- DO NOT** place air pump where air intake could be contaminated by spray booth exhaust, other spraying operations (i.e. primer application, etc.), mixing operations, auto exhausts, etc.
- DO NOT** place oil-less air pump inside spray booth or in the same area in which you are spraying.
- DO NOT** use 9805-00 (1/4 & 1/3hp) or 9810-00 (1/2hp) oil-less air pump for 2-man application.
- DO NOT** run oil-less air pump without breathing air-line and mask attached. This will cause pump to over heat and shut off.
- DO NOT** use 9805-00 (1/4 & 1/3hp) oil-less pump for hood-type respirator.
- DO NOT** use ungrounded electrical receptacles.
- DO NOT** use **ANY** electrical extension cords.
- DO NOT** close off pressure relief valve completely. This will cause pump to over heat and shut off.
- DO*** before start-up, unscrew aluminum cup on exhaust filter assembly and check that exhaust filter is firmly seated in place. Replace aluminum cup and tighten firmly.
- DO*** before start-up check intake filter to be sure it is secured to pump housing.
- DO*** change intake filter and exhaust filter every 90 to 100 running hours or if pressure drops below recommendations.
- DO*** place air inlet pump in a clean air environment where breathable air can be assured at all times.
- DO*** check pressure gauge for a minimum 4.0 PSI while air is flowing into supplied-air respirator. Pressure relief valve is factory set to deliver more than the minimum OSHA required 4.0 CFM.
- DO*** use grounded electrical connections.

GENERAL DESCRIPTION

SAS SUPPLIED AIR RESPIRATOR SYSTEMS

9800-35	ONE-MAN FULLFACE SYSTEM 1/4 HP
9814-05	Opti-Fit Full face Supplied Air Respirator - Medium
9852-42	Breathing Air Line Hose 50 ft.
9850-31	Nylon-Web Belt
7600-95	Peel-Off Lens Cover (1 Single)
9805-00	1/4 & 1/3 hp Oil-Less Carbon Vane Air Pump
9800-25	TWO-MAN FULLFACE SYSTEM 3/4 HP
9814-05	Opti-Fit Full face Supplied Air Respirator - Medium (Qty 2)
9852-42	Breathing Air Line Hose 50 ft. (Qty 2)
9850-31	Nylon-Web Belt (Qty 2)
7600-95	Peel-Off Lens Cover (2 Singles)
9810-00	3/4hp Oil-Less Carbon Vane Air Pump
9800-45	FOUR-MAN FULLFACE SYSTEM 1 1/2 HP
9814-05	Opti-Fit Full face Supplied Air Respirator - Medium (Qty 4)
9852-42	Breathing Air Line Hose 50 ft. (Qty 4)
9850-31	Nylon-Web Belt (Qty 4)
7600-95	Peel-Off Lens Cover (4 Singles)
9840-00	1 1/2 hp Oil-Less Carbon Vane Air Pump

Supplied Air Respirator - SAR

Optimum fit, comfort and superior optics in a full face respirator. Comfortable, durable silicone skirt and five-strap suspension. The Opti-Fit™ features a distortion-free lens with exceptional view. The lens is replaceable and treated with an anti-scratch coating. A nose cup is a standard feature to prevent fogging. Lightweight construction reduces head and neck stress even during extended wear. Peel-Off Lens covers available both in Clear and Tinted.

Oil-Less Carbon Vane Air Pump

The oil-less air pump produces completely oil-free air and does not generate carbon monoxide, oil vapor or oil mists. The 115V pump comes with intake and exhaust filters, pressure-relief valve, pressure gauge and airline couplings. **CAUTION:** PUMP MUST BE PLACE IN A "CLEAN-AIR" ENVIRONMENT WHERE BREATHABLE AIR CAN BE ASSURED AT ALL TIMES! If "clean air" intake cannot be guaranteed, a remote air intake may be used to assure safe breathable air for the user. Pump must not be operated in potentially explosive atmosphere.

Respiratory Protection Program

OSHA requires a Respiratory Protection Program be implemented. The SAS Instruction Manual outlines compliance requirements for employer and user.

NOT TO BE USED IN ATMOSPHERES IMMEDIATELY DANGEROUS TO LIFE OR HEALTH!

All products listed comply with the standards of the Occupational Safety and health Administration (OSHA), assuming that the materials are used as designed and engineered in accordance with instructions.

Item No.	HP	Max No. of Respirators	Max No. of Hoods	Amps / Volts	PSI	CFM
9805-00	1/4 & 1/3	1	0	9A / 115V	0 to 10	0 to 4.5
9810-00	1/2	1	1	10.8A / 115V	0 to 10	0 to 8
9820-00	3/4	2	1	10.8A / 115/230V	0 to 10	0 to 10
9840-00	1 1/2	4	3	30A / 115/230V	0 to 10	0 to 22

OIL-LESS AIR PUMP ASSEMBLY INSTRUCTIONS

9805-00 OIL-LESS AIR PUMP

PUMP IS COMPLETELY ASSEMBLED AT FACTORY

- RUBBER FEET (P/N 9700-06) AND HANDLE (P/N 9700-05) MAY BE ORDERED IF DESIRED.

9810-00 AND 9820-00 OIL-LESS AIR PUMP

- INSTALL HANDLE TOWARD PUMP FRONT END WITH HANDLE FLANGES ONTO OF MOTOR BASE. USE RUBBER FEET INSTALLATION FOR HANDLE SUPPORT
- INSTALL REMAINING RUBBER FEET WITH NUTS AND BOLTS PROVIDED.

PARTIAL PUMP ASSEMBLY HAS BEEN COMPLETED AT FACTORY:

- SCREW INLET FILTER ASSEMBLY INTO INLET PORT (MARKED "IN"). IF INLET HOSE KITS ARE TO BE USED FOR REMOTE LOCATION OF INLET AIR
- INSTALL EXHAUST FILTER HOUSING ASSEMBLY WITH PRESSURE GAUGE AND HOSE COUPLING (PRE-ASSEMBLED AT FACTORY) TO OUTLET "TEE" EXHAUST PORT.

9840-00 OIL-LESS AIR PUMP

PARTIAL PUMP ASSEMBLY HAS BEEN COMPLETED AT FACTORY:

- SCREW INLET FILTER ASSEMBLY INTO INLET PORT (MARKED "IN"). IF INLET HOSE KITS ARE TO BE USED FOR REMOTE LOCATION OF INLET AIR
- INSTALL EXHAUST FILTER HOUSING ASSEMBLY WITH PRESSURE GAUGE AND HOSE COUPLING (PRE-ASSEMBLED AT FACTORY) TO OUTLET "TEE" EXHAUST PORT.

OIL-LESS AIR PUMP OPERATING INSTRUCTIONS

MODEL # 9805-00, 9810-00, 9820-00 & 9840-00

- FOR RESPIRATOR AND AIR-LINE ASSEMBLIES, PRESSURE RELIEF VALVE IS FACTORY SET AT MINIMUM 4.0 PSI FOR USE WITH 50 TO 100 FOOT AIR-SUPPLY LINE. **DO NOT** CLOSE OFF PRESSURE RELIEF WHERE NO AIR CAN ESCAPE.

IMPORTANT -- FOR RESPIRATOR SYSTEMS OTHER THAN SAS SAFETY CORP.

- FOR RESPIRATOR AIR-LINE SYSTEMS OTHER THAN SAS. ADJUST PRESSURE RELIEF VALVE IF NECESSARY.
- USE PRESSURE RELIEF VALVE AS A ADJUSTMENT DEVICE. DELIBERATELY "BLEED OFF" AIR TO ACHIEVE DESIRED GAUGE READING.
- GAUGE READING SHOULD CONFORM TO MSHA/NIOSH APPROVED MINIMUMS FOR EACH SPECIFIC RESPIRATOR MODE MANUFACTURER'S OWNER'S MANUALS OR INSTRUCTIONS WILL SPECIFY THESE PRESSURE RANGES.
- COUPLING MAY NEED TO BE REPLACED ON PUMP IF AIR-LINE CONNECTION IS OTHER THAN SAS SAFETY CORP. THIS DOES NOT VIOLATE NIOSH APPROVAL (DO NOT CHANGE FITTINGS ON HOSE AS THIS COULD NULLIFY RESPIRATOR NIOSH APPROVAL)

1/4 & 1/3 HP OIL-LESS AIR PUMP

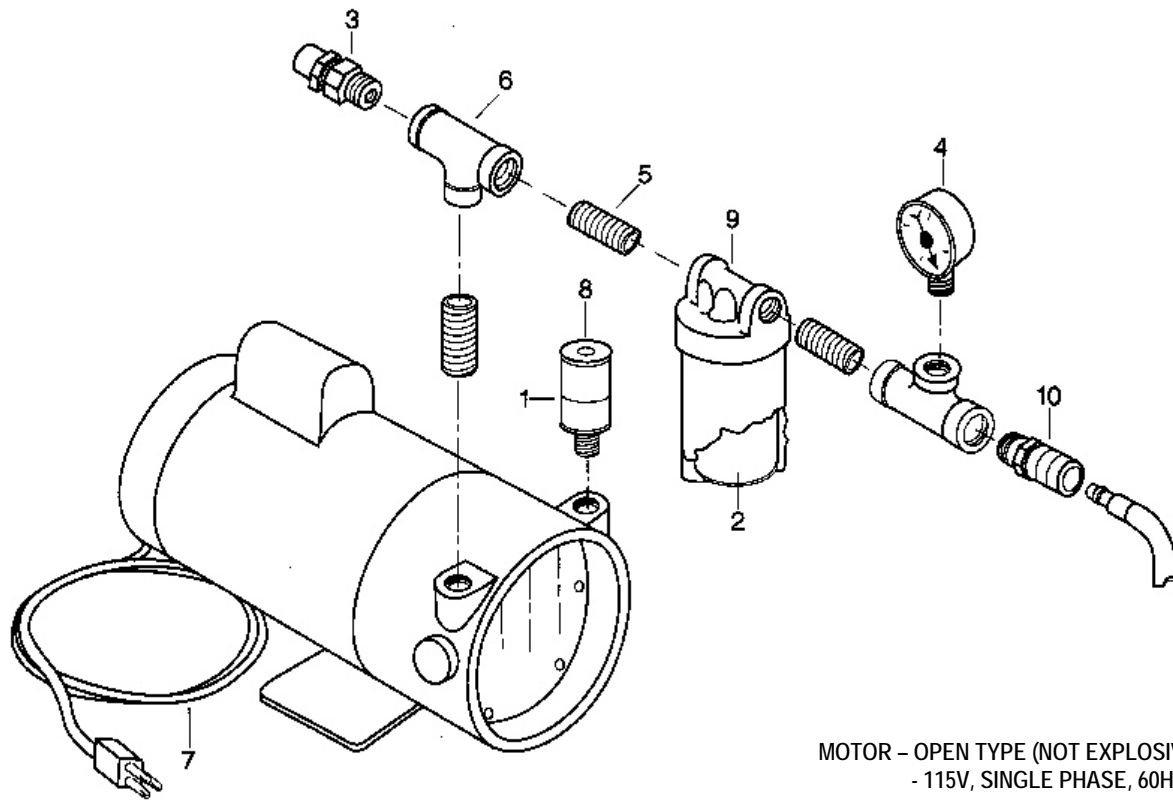

MOTOR – OPEN TYPE (NOT EXPLOSIVE PROOF)
- 115V, SINGLE PHASE, 60HZ

ITEM	PART NUMBER	DESCRIPTION
1	9700-14	INTAKE FILTER ELEMENT
2	9700-02	EXHAUST FILTER ELEMENT
3	9700-19	PRESSURE RELIEF VALVE
4	9700-04	PRESSURE GAUGE
5	0200-002	1/4" HEX NIPPLE
6	0200-021	1/4" BRASS "T"
7	9700-07	ELECTRIC CORD, W/GROUND PLUG
8	9700-21	INTAKE FILTER ASSEMBLY
9	9700-22	EXHAUST FILTER ASSEMBLY
10	9700-10	1/4" NPT MALE COUPLER
	9700-11	PUMP CLEANING SOLUTION (Not Shown)
	9700-25	INLET HOSE KIT – 25 ft. (Not Shown)
	9700-30	INLET HOSE KIT – 25 ft. (Not Shown)
	9700-40	SERVICE KIT – VANES, FILTER & PUMP CLEANER (Not Shown)

Warning: Exhaust filter DOES NOT REMOVE dangerous organic vapors or gases. DO NOT USE this equipment if organic vapors or gases are present. If this air pump is to be used as a breathing air source, the air inlet MUST be located in a CLEAN AIR area where breathable air can be assured at all times

1/2 & 3/4 HP OIL-LESS AIR PUMP

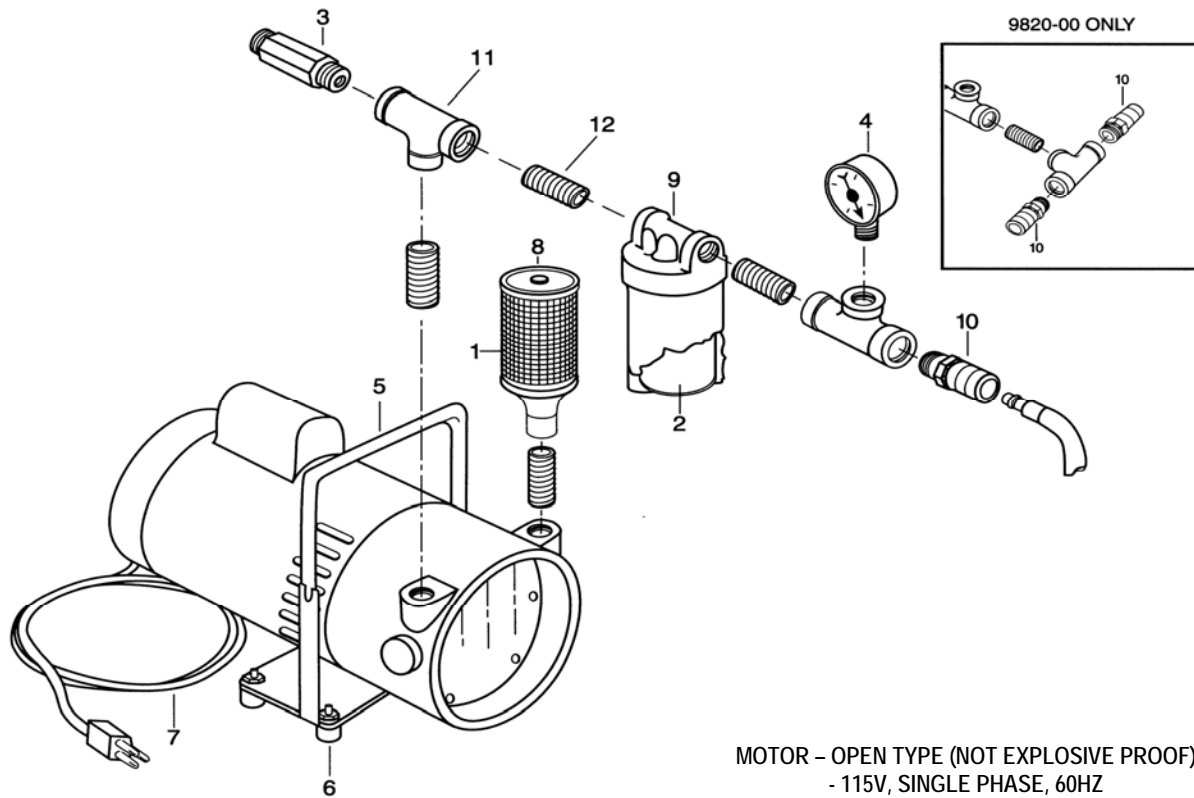

MOTOR - OPEN TYPE (NOT EXPLOSIVE PROOF)
- 115V, SINGLE PHASE, 60HZ

ITEM	PART NUMBER	DESCRIPTION
1	9700-01	INTAKE FILTER ELEMENT
2	9700-02	EXHAUST FILTER ELEMENT
3	9700-03	PRESSURE RELIEF VALVE
4	9700-04	PRESSURE GAUGE
5	9700-05	CARRYING HANDLE
6	9700-06	4 RUBBER FEET, W/NUTS & BOLTS
7	9700-07	ELECTRIC CORD, W/GROUND PLUG
8	9700-08	INTAKE FILTER ASSEMBLY
9	9700-09	EXHAUST FILTER ASSEMBLY
10	9700-10	1/4" NPT MALE COUPLER
	0200-02	3/8" BRASS "T"
	0200-03	3/8" HEX NIPPLE
	9700-11	PUMP CLEANING SOLUTION (Not Shown)
	9700-25	INLET HOSE KIT - 25 ft. (Not Shown)
	9700-30	INLET HOSE KIT - 25 ft. (Not Shown)
	9700-50	SERVICE KIT - VANES, FILTER & PUMP CLEANER (Not Shown)

Warning: Exhaust filter DOES NOT REMOVE dangerous organic vapors or gases. DO NOT USE this equipment if organic vapors or gases are present. If this air pump is to be used as a breathing air source, the air inlet MUST be located in a CLEAN AIR area where breathable air can be assured at all times.

1 1/2 OIL-LESS AIR PUMP

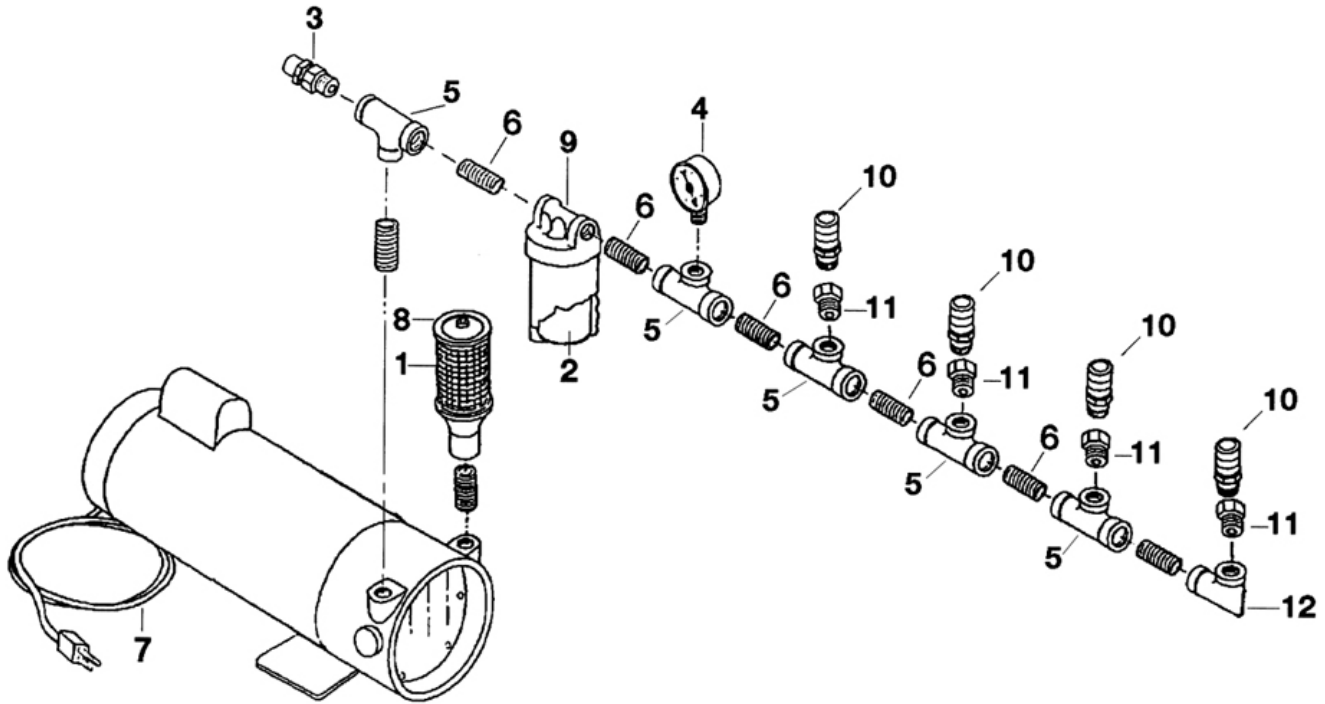

MOTOR - OPEN TYPE (NOT EXPLOSIVE PROOF)
- 115V, SINGLE PHASE, 60HZ

ITEM	PART NUMBER	DESCRIPTION
1	9700-01	INTAKE FILTER ELEMENT
2	9700-02	EXHAUST FILTER ELEMENT
3	9700-03	PRESSURE RELIEF VALVE
4	9700-04	PRESSURE GAUGE
5	9700-05	3/4" BRASS "T"
6	9700-06	3/4" HEX NIPPLE
7	9700-07	ELECTRIC CORD, W/GROUND PLUG
8	9700-08	INTAKE FILTER ASSEMBLY
9	9700-09	EXHAUST FILTER ASSEMBLY
10	9700-10	1/4" NPT MALE COUPLER
11	0200-054	3/4" TO 1/4" REDUCER
12	0200-074	3/4" BRASS ELBOW
	9700-11	PUMP CLEANING SOLUTION (Not Shown)
	9840-25	INLET HOSE KIT - 25 ft. (Not Shown)
	9840-30	INLET HOSE KIT - 25 ft. (Not Shown)

Warning: Exhaust filter DOES NOT REMOVE dangerous organic vapors or gases. DO NOT USE this equipment if organic vapors or gases are present. If this air pump is to be used as a breathing air source, the air inlet MUST be located in a CLEAN AIR area where breathable air can be assured at all times.

HOW TO GET TOP PERFORMANCE AND LONG LIFE FROM SAS PUMPS

GENERAL INFORMATION:

This pump is only to be used for the purpose of pumping air and under NO circumstances be used with any other gases. The pump must not be used for the pumping of fluids, particles, solids or any substance mixed with air, particularly combustible substances likely to cause explosions. Your rotary pump is a precision product with a clearance of Top .0015" End .0015" for model 0523 (1/4 HP & 1/3HP) and Top .003" End .002" for models 0823 and 1023 (1/2HP and 3/4HP). Foreign particles or excessive dirt and/or dust could cause eventual "jamming" of the pump. The unit is built of steel and cast iron and is designed for pumping dry air. Consequently, any moisture (especially when pump stands idle) will tend to corrode interior. The Carbon Vanes life is between 5,000 - 15,000 hours depending upon application.

NEVER lubricate this oil-less rotary vane pump. The sealed bearing are grease-packed. The service life of the carbon vanes will be reduced by petroleum or hydrocarbon products. Precision ground vanes take up their own wear and will last thousands of hours depending upon speed and degree of pressure. Excessive dirt, foreign particles, or moisture could cause the vanes to stick in the rotor slots and even break.. Periodic "Flushing" could prevent this see page 10.

PRODUCT USE CRITERIA:

Pump only clean, dry air and operate at 32°F - 104°F (0° C - 40°C). Protect unit from dirt and moisture. Do not pump flammable or explosive gases or use in an atmosphere that contains such gases.

INSTALLATION:

WARNING ELECTRICAL SHOCK HAZARD:

Disconnect electrical power at the circuit breaker or fuse box before installing this product. Install this product where it will not come into contact with water or other liquids. Install this product where it will be weather protected. Electrically ground this product. Failure to follow these instructions can result in death, fire or electrical shock.

CAUTION: Blocking air flow around the product in any way can cause the product to over heat and shut off.

MOUNTING:

This product may be installed in any orientation. Mounting the product to a stable, rigid operating surface and using shock mounts will reduce noise and vibration.

INSPECTION:

Regular inspection, cleaning filters, and "flushing" (see page 10) may prevent extensive repairs. Dirty or clogged intake filter felt can be responsible for failure of the pump to build up pressure and eventual pump overheating. Replace exhaust filter element every 90 to 100 running hours. Do not be alarmed if temperature of exhaust air reaches 225°F when running continuously. If there is evidence of overheating or excessive noise, stop immediately for repairs. Keep external surfaces clean for proper heat dissipation. Most failures to build up pressure are due to leaks in connecting lines, damaged filter jar threads, collapsed air lines, dirty filtering elements or sluggish vanes in the pump. The latter is generally caused from the pump being operated above its recommended duty and getting too hot.

START UP:

If the motor fails to start or slows down significantly under load, shut off and disconnect from power supply. Check that the voltage is correct for motor and the motor is turning in the proper direction. Vane life will be drastically reduced if motor is not operating properly. Vanes can break or be damaged if motor/pump runs in the wrong direction. Motors are equipped with thermal protector that turns current off automatically when there is mechanical or electrical overloads. Also check the wiring instructions on motor case or on thermal plate cover.

LUBRICATION:

CAUTION: **NEVER LUBRICATE DRY "OIL-LESS" AIR PUMPS.** The carbon vanes and grease packed bearings require NO oil.

FLUSHING:

Flushing this product to remove excessive dirt, foreign particles, moisture or oil that occurs in the operating environment will help to maintain proper vane performance. Most pump troubles can be corrected by flushing solvent rather than by taking apart. A noisy or inefficient pump is frequently nothing more serious than vanes stuck in a rotor slot due to foreign material (dust) and / or dirty filters.

CAUTION -- Recommended commercial solvents for SAS pumps are Loctite Safety Solvent, Inhibisol Safety Solvent, and Dow Chemical Chloroethane. In the event one of the above are not available, use any NON-FLAMMABLE, NON-TOXIC, NON-PETROLEUM BASE, INDUSTRIAL CLEANING SOLVENT. (SAS PUMP FLUSHING LIQUID --- P/N 9700-11).

FLUSHING PROCEDURES:

Remove Intake Filter Assembly and Exhaust Port Assembly. Flushing should be done while the unit is running and in a well ventilated area. Then while wearing proper protection have a clean cloth over the exhaust port marked "OUT". Spray or pour a small amount of flushing solution in the intake port marked "IN". Continue flushing until solution coming out exhaust port appears to be clear. After all solvent has passed through the pump continue to let the pump run while unseen solution can dissipate into the air, then re-attach the Intake Filter Assembly to the port marked "IN" and Exhaust Port Assembly to the port marked "OUT". Frequent flushing is recommended to help maintain proper vane performance.

FILTER ELEMENTS:

Replace Intake and Exhaust Filter every 90 to 100 running hours.

DISASSEMBLY:

If foreign matter has entered pump, try flushing. If this does not eliminate the foreign matter, unplug pump, remove only the dead end plate and the four vanes (**DO NOT** at any time remove the rotor). Wash vanes, end plate, and pump chamber with solvent (see above for correct type of solvents to be used). Dry and reassemble.

DANGER: TO PREVENT EXPLOSIVE HAZARD, DO NOT PUMP COMBUSTIBLE LIQUIDS OR VAPORS WITH ANY SAS UNIT.

FOR MAXIMUM PUMP LIFE USE MINIMUM PRESSURE NEEDED TO DO THE JOB.

TROUBLE SHOOTING CHART

Reason and remedy for Problem	Low Pressure	High Pressure	Pump Overheat	Motor Overheat
Filter(s) dirty Clean or replace	X			
Relief valve set to high Inspect and adjust			X	
Relief valve set to low. Inspect and adjust	X			
Plugged vacuum / pressure line. Inspect and adjust	X	At Pump	X	X
Vanes sticking. Clean or replace	X			
Vanes worn. Replace	X			
Shaft seal worn. Replace	X			
Dust or offset powder in pump. Inspect and clean	X		X	X
Motor not wired correctly. Check wiring diagram and line voltage.	X		X	X
Damaged jar thread. Replace	X		X	X
Damaged jar gasket. Replace	X			
Plugged pressure line. Inspect and/or replace	X	At Pump	X	X
Running to high RPM. Inspect and adjust		X	X	X

INLET HOSE KIT INSTRUCTION SHEET

CONTROL OF AIR QUALITY

Respirators must be supplied with clean, breathable air at ALL times.

OSHA 29CFR 1910.134

Locate oil-less air pump in a clean environment where breathable air can be assured at all times.

NOTE:

If clean air CANNOT be guaranteed at all times, use Part No. 9700-25 or 9840-25 Inlet Hose kit permitting remote location of air inlet 25 ft from oil-less pump.

Additional 25 ft corrugated inlet hose extension sections, Part No. 9700-30 or 9840-30, may be added. To assure quality of air, the combined maximum length of breathing air and inlet hose cannot exceed 300 ft.

WARNING:

Place inlet filter assembly where breathing air CANNOT be contaminated by spray booth exhaust, paint mixing operations, other spray operations, auto or other machinery exhaust, harmful vapors and gases, etc...

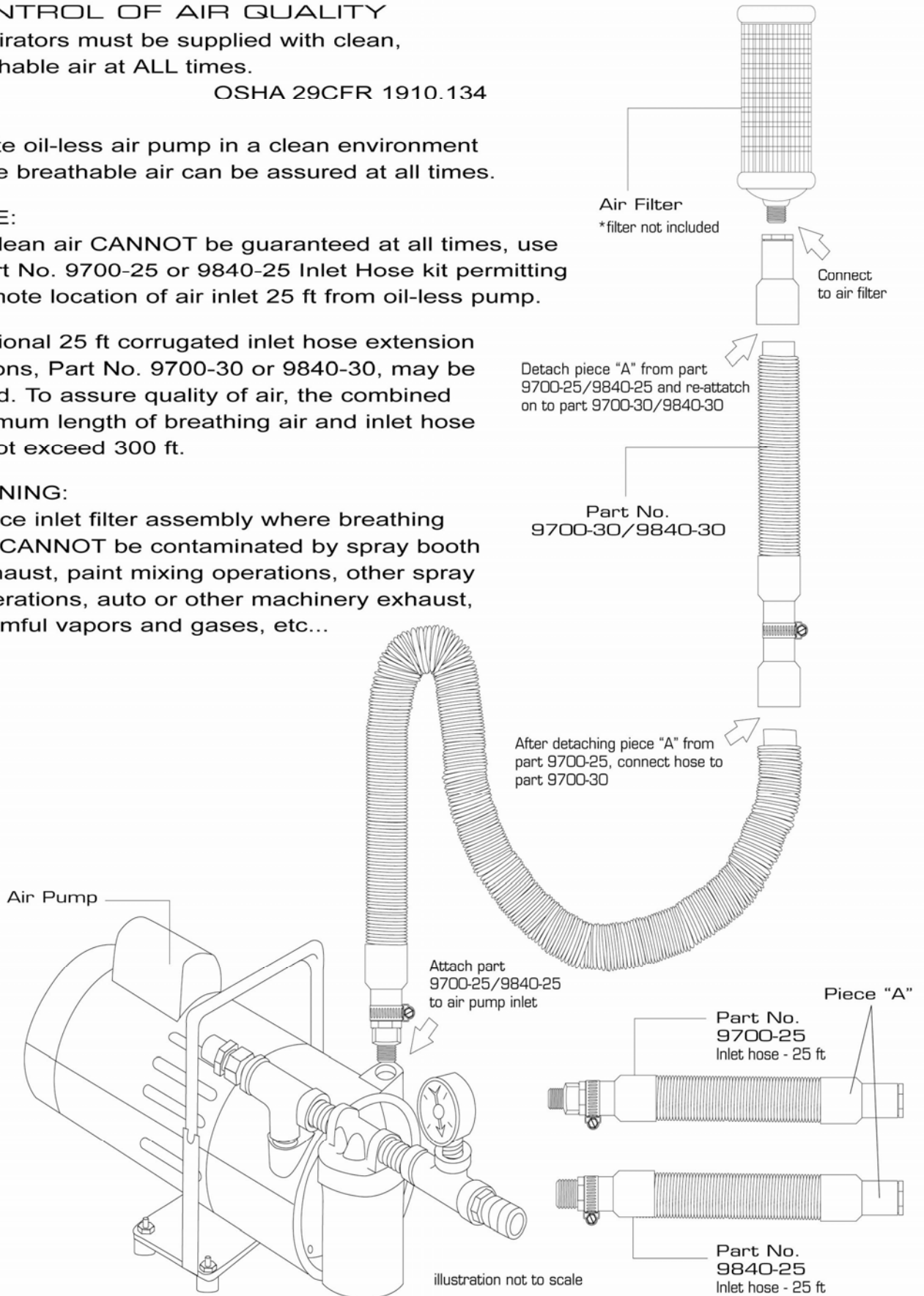

SUPPLIED-AIR FULL FACE MODEL 9814 SERIES

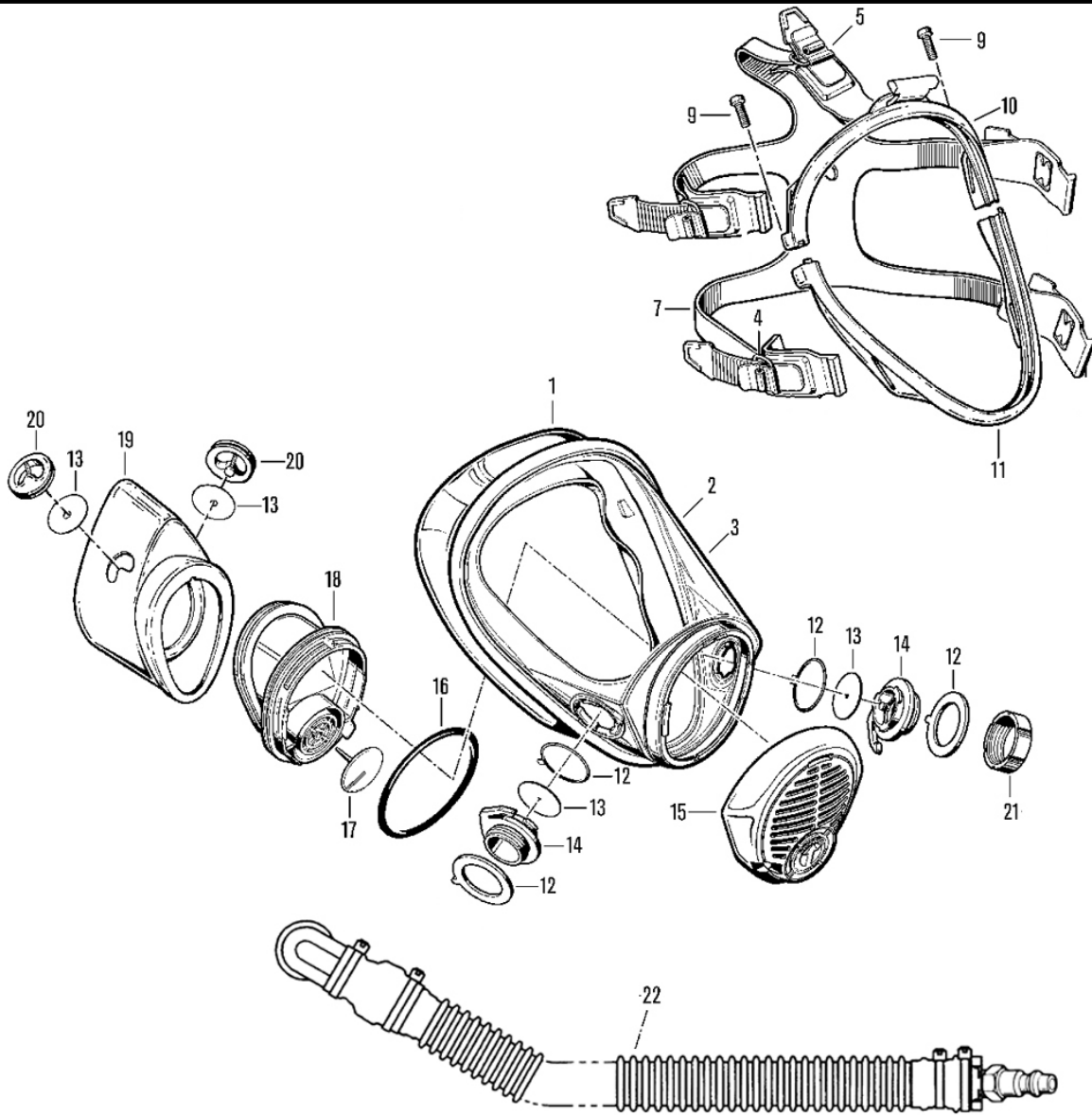

ITEM	PART NUMBER	DESCRIPTION	ITEM	PART NUMBER	DESCRIPTION
1	9621-57	Skirt, Small (Incl. #'s 2-20)	12	7620-37	Twin Seal (2 req.)
	9621-67	Skirt, Medium (Incl. #'s 2-20)	13	1400-01	Inhalation Valve
	9621-77	Skirt, Large (Incl. #'s 2-20)	14	7620-35	Connector, Threaded
2	7620-07	Lens Replacement	15	7620-04	Nozzle Cover
3	7600-95	Peel-Off Lens Cover	16	8202-61	O-Ring
4	7620-13	Short Buckle Strap Kit	17	1400-05	Exhalation Valve
5	7620-19	Long Buckle Strap Kit	18	7620-03	Nozzle
7	7620-09	Headstrap, TPE	19	7620-23	Nose Cup
9	8391-02	Screw (2 req.)	20	7620-90	Valve Holder (2 req.)
10	7620-31	Rim, Upper	21	9850-20	Cap
11	7620-37	Rim, Lower	22	9813-72	Downtube Assembly

USER INSTRUCTIONS

LOW PRESSURE SUPPLIED-AIR RESPIRATOR, TYPE C CONSTANT FLOW CLASS FULLFACE RESPIRATOR.

SAFETY PRECAUTIONS

Warnings, Causation and Notes used in this manual have the following significance:

WARNING

Maintenance or operation procedures and techniques will result in personal injury or loss of life if not carefully followed.

CAUTION

Maintenance or operation procedures and techniques will result in damage to equipment if not carefully followed.

NOTE

Maintenance or operating procedures and techniques that are considered important enough to emphasize.

DESCRIPTION

Supplied Air Respirators provide long duration respiratory protection in toxic atmospheres. Air is supplied to the facepiece through a hoseline.

WARNING

1. Selection or use of this respirator must be done in accordance with American National Standard Practices for Respiratory Protection Z88.2 and the Occupational Safety and Health statutes to which you are subjected.
2. DO NOT use this facepiece on a pressure demand unit. Fullface Supplied Air Respirators are approved by the Mine Safety and Health Administration (MSHA) and the National Institute for Occupational Safety and Health (NIOSH).
3. DO NOT wear supplied air respirators in any atmosphere that is immediately dangerous to life or health. "Atmospheres immediately dangerous to life or health" are:
 - a. Those which the wearer could not breath for short periods.
 - b. Those from which the wearer could not escape without the aid of the respirator.
 - c. Those which would have an immediate or delayed adverse effect on health.

COMPONENTS:

Each Fullface Supplied-Air Respirator consists of the following major components: Face piece Assembly, Down-Tube Assembly, Nylon-Web Waist Belt, 50 ft. Breathing Air Supply Line.

Use only the components having the part numbers listed on the MSHA/NIOSH approval plate. Use of any other components voids the approval.

Accessories:

To extend the utility of the Full face Supplied-Air respirator, the following accessories are offered as option equipment.

Opti-Fit Fullface

Spectacle Kit	7622-60
Lens Cover Clear	7600-95
Lens Cover Shade	7600-96

PREPARATION FOR USE

Air Supply:

A. PURITY

Unless safety and health codes in your area specify otherwise, air purity must meet the requirements of Type 1, Grade D gaseous air set forth in the Compressed Gas Association Commodity Specification for Air, G-7.1. The responsibility of maintaining the quality of the air is yours. Install purification and monitoring equipment as necessary.

B. PRESSURE

Pressure relief valve on SAS pump is factory set for maximum air flow. Pressure of the air supply must be maintained within the range specified for the length of air supply line, measured at the inlet to the air supply line. Refer to respirator manufacturer's recommendation for specific settings.

WARNING

If a compressor is used to supply breathing air, the following precautions must be taken:

- A. The compressor air intake must be located so that only clean, fresh air is drawn into the compressor. Be especially careful that toxic gases are not drawn in. Locate the air intake away from engine exhausts, spray paint exhausts, over spray, chemical processes, and/or dust sources.
- B. The responsibility for compliance with safety and health codes, applicable to you area, is YOURS.

LENGTH OF HOSELINE

The length of hoseline to be used will be determined by the job to be done. In **NO** case may the hose length exceed 100 feet.

OPERATING INSTRUCTIONS

Donning:

1. Connect the air supply hose to the air supply.
2. Put the waist belt on. tighten the belt snugly around your waist.
3. Tuck the Full face mask under your arm and attach the clip-on end of the low pressure hose (downtube) coming from your mask to the ring on your waist belt. Attach it so the plug on the end of the hose pints rearward.

4. Plug the end of the low pressure hose coming from your mask into the hoseline and turn on the air supply. Your mask should now be supplying air.
5. Don the Full face mask:
 - 5.1 Full face Mask:
 - a. Extend all headstraps to their full length.
 - b. Push the whole headstrap up and over the "forehead" part of the mask as far as possible.
 - c. Insert your chin into the Face piece first, then pull the headstraps down over the back of your head and down as far as they will go.
6. Tighten the straps -- lower straps first, then the upper straps. The straps must be tight enough so that they securely hold the Full face mask on and prevent leakage. Do not make them so tight that you become uncomfortable.
7. Your respirator is now ready to use.

PERIODIC INSPECTION

NOTE

The Supplied-Air Respirator should be inspected for defects after each use, and at least once monthly if it is not used. The Supplied-Air Respirator should be repaired as necessary, cleaned and disinfected, and then stored properly to assure that it is maintained in satisfactory working condition. A record should be kept of inspection dates and findings.

INSPECTION

1. **WAIST BELT:** Check the waist belt for broken, twisted, or excessively frayed straps, defective or excessively rusty buckles: defective stitching, and cuts, tears, or holes.
2. **FACEPIECE:** The face piece skirt and headstrap should be inspected for pliability and signs of deterioration. Stretching and manipulating the rubber with a massaging action will keep it pliable, flexible and prevent it from taking a set during storage. All parts, and especially the lens, should be clean and free of dirt and dust. Examine the buckles to see that they function properly and free of excessive rust. Check the face piece for leaks. Special attention should be given to the exhalation valve and the joint between the lens and the skirt.
3. **HOSE:** Inspect the mask and air supply hose for leaks, cuts, cracks, and abrasions. Check the end fittings for tightness.

CLEANING:

1. For sanitary reasons, the respirator face piece should be cleaned and disinfected after each use, even if it does not look dirty.
2. Make a cleaning solution by mixing water with any detergent that contains effective disinfectants (such as quaternary ammonium compounds).
3. Heat the solution to 140-160° F. (60 - 71.1° C).
4. Immerse the face piece, top first, in the cleaning solution. Immerse it only until the exhalation valve is covered.
5. Using a soft brush, gently clean the face piece
6. Rinse the face piece in a fresh-water bath and allow it to air dry. Mild heat (less than 160° F, 71.1° C) may be used to speed up the drying. Use of towel to dry the face piece is not recommended unless a clean, lint free towel is used.

7. Use caution when cleaning the face piece lens. Although the outer surface of the lens has a proprietary anti-scratch coating, it can be damaged through careless or abusive handling. Do not attempt to "polish out" scratches with any abrasive agent as this will only cause further damage to the remaining coating. Warm, soapy water (using Joy, Mr. Clean, Lestoil, etc.) is usually adequate to remove adhering grime. Stubborn deposits may require the use of denatured or isopropyl alcohol or other mild solvents. DO NOT allow any solvent to come into contact with rubber or plastic parts. Use solvents only in a well-ventilated area.

REPAIR:

Repair of the Supplied Air Respirator by the user is limited to replacement of the components as listed on the MSHA/NIOSH approval label. Disassembly should be performed only to the extent necessary to replace the components.

WARNING

Before disassembly, make sure that all air is bled from the lines. Shut off or deplete the air supply to prevent equipment damage or personal injury.

To protect your warranty and the MSHA/NIOSH certification on the equipment, all other repairs must be done only by authorized Service Center. If there are none at your facility, consult your SURVIVAIR distributor for the one nearest you.

STORAGE:

After inspection, cleaning and necessary repair, the Supplied-Air Respirator should be stored to protect it against dust, sunlight, heat, extreme cold, excessive moisture, or damaging chemicals. The Supplied Air Respirator should be stored in compartments built for that purpose. The compartments should be clearly marked.

Spectacle Kit
P/N 7622-60
FOR USE WITH OPTI-FIT MASKS

INSTALLATION INSTRUCTIONS

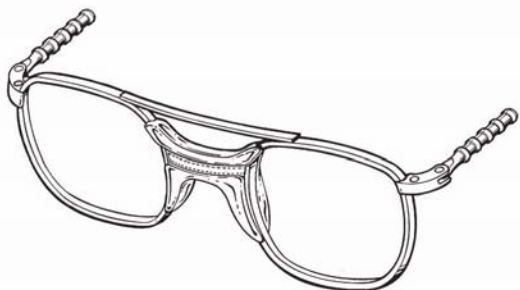

1. TAKE FRAMES AND TEMPLE BARS TO AN OPTICIAN FOR INSTALLATION OF PRESCRIPTION LENSES. (YOU WILL NEED YOUR PRESCRIPTION) FRAMES USE 48mm SIZE LENS ONLY.
2. INSERT SPECTACLE TEMPLE BARS INTO HOLES IN TABS ON INSIDE OF MASK SKIRT.
3. POSITION SPECTACLES AS DESIRED.

**OSHA Occupational Safety & Health Administration
U.S. Department of Labor**

OSHA Regulations (Standards - 29 CFR) - 1910....

1910.134 - Respiratory Protection.

Standard Number: 1910.134

Standard Title: Respiratory Protection

Subpart Number: I

Subpart Title: Personal Protective Equipment

**Produced by USDOL OSHA - Directorate of Safety Standards &
Directorate of Health Standards**

Maintained by USDOL OSHA- OCIS

(a)

* *Permissible practice.*

(a)(1)

* In the control of those occupational diseases caused by breathing air contaminated with harmful dusts, fogs, fumes, mists, gases, smokes, sprays, or vapors, the primary objective shall be to prevent atmospheric contamination. This shall be accomplished as far as feasible by accepted engineering control measures (for example, enclosure or confinement of the operation, general and local ventilation, and substitution of less toxic materials). When effective engineering controls are not feasible, or while they are being instituted, appropriate respirators shall be used pursuant to this section.

(a)(2)

* Respirators shall be provided by the employer when such equipment is necessary to protect the health of the employee. The employer shall provide the respirators which are applicable and suitable for the purpose intended. The employer shall be responsible for the establishment and maintenance of a respiratory protection program which shall include the requirements outlined in paragraph (c) of this section.

...1910.134(b)

(b)

* *Definitions.* The following definitions are important terms used in the respiratory protection standard in this section.

* *Air-purifying respirator* means a respirator with an air-purifying filter, cartridge, or canister that removes specific air contaminants by passing ambient air through the air-purifying element.

* *Assigned protection factor (APF)* [Reserved]

* *Atmosphere -supplying respirator* means a respirator that supplies the respirator user with breathing air from a source independent of the ambient atmosphere, and includes supplied-air respirators (SARs) and self-contained breathing apparatus (SCBA) units.

- * *Canister or cartridge* means a container with a filter, sorbent, or catalyst, or combination of these items, which removes specific contaminants from the air passed through the container.
- * *Demand respirator* means an atmosphere-supplying respirator that admits breathing air to the face piece only when a negative pressure is created inside the face piece by inhalation.
- * *Emergency situation* means any occurrence such as, but not limited to, equipment failure, rupture of containers, or failure of control equipment that may or does result in an uncontrolled significant release of an airborne contaminant.
- * *Employee exposure* means exposure to a concentration of an airborne contaminant that would occur if the employee were not using respiratory protection.
- * *End-of-service-life indicator (ESLI)* means a system that warns the respirator user of the approach of the end of adequate respiratory protection, for example, that the sorbent is approaching saturation or is no longer effective.
- * *Escape-only respirator* means a respirator intended to be used only for emergency exit.
- * *Filter or air purifying element* means a component used in respirators to remove solid or liquid aerosols from the inspired air.
- * *Filtering face piece (dust mask)* means a negative pressure particulate respirator with a filter as an integral part of the face piece or with the entire face piece composed of the filtering medium.
- * *Fit factor* means a quantitative estimate of the fit of a particular respirator to a specific individual, and typically estimates the ratio of the concentration of a substance in ambient air to its concentration inside the respirator when worn.
- * *Fit test* means the use of a protocol to qualitatively or quantitatively evaluate the fit of a respirator on an individual. (See also Qualitative fit test QLFT and Quantitative fit test QNFT.)
- * *Helmet* means a rigid respiratory inlet covering that also provides head protection against impact and penetration.
- * *High efficiency particulate air (HEPA) filter* means a filter that is at least 99.97% efficient in removing monodisperse particles of 0.3 micrometers in diameter. The equivalent NIOSH 42 CFR 84 particulate filters are the N100, R100, and P100 filters.
- * *Hood* means a respiratory inlet covering that completely covers the head and neck and may also cover portions of the shoulders and torso.
- * *Immediately dangerous to life or health (IDLH)* means an atmosphere that poses an immediate threat to life, would cause irreversible adverse health effects, or would impair an individual's ability to escape from a dangerous atmosphere.
- * *Interior structural firefighting* means the physical activity of fire suppression, rescue or both, inside of buildings or enclosed structures which are involved in a fire situation beyond the incipient stage. (See 29 CFR 1910.155)

- * *Loose-fitting face piece* means a respiratory inlet covering that is designed to form a partial seal with the face.
- * *Maximum use concentration (MUC)* [Reserved]
- * *Negative pressure respirator (tight fitting)* means a respirator in which the air pressure inside the face piece is negative during inhalation with respect to the ambient air pressure outside the respirator.
- * *Oxygen deficient atmosphere* means an atmosphere with an oxygen content below 19.5% by volume.
- * *Physician or other licensed health care professional (PLHCP)* means an individual whose legally permitted scope of practice (i.e., license, registration, or certification) allows him or her to independently provide, or be delegated to the responsibility to provide, some or all of the health care services required by paragraph (e) of this section.
- * *Positive pressure respirator* means a respirator in which the pressure inside the respiratory inlet covering exceeds the ambient air pressure outside the respirator.
- * *Powered air purifying respirator (PAPR)* means an air-purifying respirator that uses a blower to force the ambient air through air-purifying elements to the inlet covering.
- * *Pressure demand respirator* means a positive pressure atmosphere-supplying respirator that admits breathing air to the face piece when the positive pressure is reduced inside the face piece by inhalation.
- * *Qualitative fit test (QLFT)* means a pass/fail fit test to assess the adequacy of respirator fit that relies on the individual's response to the test agent.
- * *Quantitative fit test (QNFT)* means an assessment of the adequacy of respirator fit by numerically measuring the amount of leakage into the respirator.
- * *Respiratory inlet covering* means that portion of a respirator that forms the protective barrier between the user's respiratory tract and an air-purifying device or breathing air source, or both. It may be a face piece, helmet, hood, suit, or a mouthpiece respirator with a nose clamp.
- * *Self-contained breathing apparatus (SCBA)* means an atmosphere-supplying respirator for which the breathing air source is designed to be carried to the user.
- * *Service life* means the period of time that a respirator, filter or sorbent, or other respiratory equipment provides protection to the wearer.
- * *Supplied-air respirator (SAR) or airline respirator* means an atmosphere-supplying respirator for which the source of breathing air is not designed to be carried by the user.
- * *This section* means this respiratory protection standard.
- * *Tight -fitting face piece* means a respiratory inlet covering that forms a complete seal with the face.

* *User seal check* means an action conducted by the respirator user to determine if the respirator is properly seated to the face.

(c)

* *Respiratory protection program.* This paragraph requires the employer to develop and implement a written respiratory protection program with required worksite-specific procedures and elements for required respirator use. The program must be administered by a suitably trained program administrator. In addition, certain program element may be required for voluntary use to prevent potential hazards associated with the use of the respirator. The Small Entity Compliance Guide contains criteria for the selection of a program administrator and a sample program that meets the requirements of this paragraph. Copies of the Small Entity Compliance Guide will be available on or about April 8, 1998 from the Occupational Safety and Health Administration's Office of Publications, Room N 3101, 200 Constitution Avenue, NW, Washington, DC 20210 (202) 219-4667.

(c)(1)

* In any workplace where respirators are necessary to protect the health of the employee or whenever respirators are required by the employer, the employer shall establish and implement a written respiratory protection program with worksite-specific procedures. The program shall be updated as necessary to reflect those changes in workplace conditions that affect respirator use. The employer shall include in the program the following provisions of this section, as applicable:

(c)(1)(i)

* Procedures for selecting respirators for use in the workplace;

(c)(1)(ii)

* Medical evaluations of employees required to use respirators;

(c)(1)(iii)

* Fit testing procedures for tight-fitting respirators;

(c)(1)(iv)

* Procedures for proper use of respirators in routine and reasonably foreseeable emergency situations;

(c)(1)(v)

* Procedures and schedules for cleaning, disinfecting, storing, inspecting, repairing, discarding, and otherwise maintaining respirators;

(c)(1)(vi)

* Procedures to ensure adequate air quality, quantity, and flow of breathing air for atmosphere-supplying respirators;

(c)(1)(vii)

* Training if employees in the respiratory hazards to which they are potentially exposed during routine and emergency situations;

.. 1910.134(c)(1)(viii)

(c)(1)(viii)

* Training of employees in the proper use of respirators, including putting on and removing them, any limitations on their use, and their maintenance; and

(c)(1)(ix)

* Procedures for regularly evaluating the effectiveness of this program.

(c)(2)

* Where respirator use is not required:

(c)(1)(i)

* An employer may provide respirators at the request of employees or permit employees to use their own respirators, if the employer determines that such respirator use will not in itself create a hazard. If the employer determines that any voluntary respirator use is permissible, the employer shall provide the respirator users with the information contained in Appendix D to this section ("Information for Employees Using Respirators When Not Required Under the Standard"); and

(c)(2)(ii)

* In addition, the employer must establish and implement those elements of a written respiratory protection program necessary to ensure that any employee using a respirator voluntarily is medically able to use that respirator, and that the respirator is cleaned, stored, and maintained so that its use does not present a health hazard to the user. Exception: Employers are not required to include in a written respiratory protection program those employees whose only use of respirators involves the voluntary use of filtering face pieces (dust masks).

(c)(3)

* The employer shall designate a program administrator who is qualified by appropriate training or experience that is commensurate with the complexity of the program to administer or oversee the respiratory protection program and conduct the required evaluations of program effectiveness.

(c)(4)

* The employer shall provide respirators, training, and medical evaluations at no cost to the employee.

(d)

* *Selection of respirators.* This paragraph requires the employer to evaluate respiratory hazard(s) in the workplace, identify relevant workplace and user factors, and base respirator selection on these factors. The paragraph also specifies appropriately protective respirators for use in IDLH atmospheres, and limits the selection and use of air-purifying respirators.

(d)(1)

* *General requirements.*

(d)(1)(i)

* **(i)** The employer shall select and provide an appropriate respirator based on the respiratory hazard(s) to which the worker is exposed and workplace and user factors that affect respirator performance and reliability.

(d)(1)(ii)

* The employer shall select a NIOSH-certified respirator. The respirator shall be used in

compliance with the conditions of its certification.

(d)(1)(iii)

* The employer shall identify and evaluate the respiratory hazard(s) in the workplace; this evaluation shall include a reasonable estimate of employee exposures to respiratory hazard(s) and an identification of the contaminant's chemical state and physical form. Where the employer cannot identify or reasonably estimate the employee exposure, the employer shall consider the atmosphere to be IDHL.

..1910.134(d)(1)(iv)

(d)(1)(iv)

* The employer shall select respirators from a sufficient number of respirator models and sizes so that the respirator is acceptable to, and reasonably fits, the user.

(d)(2)

* *Respirators for IDLH atmospheres.*

(d)(2)(i)

* The employer shall provide for the following respirators for employee use in IDLH atmospheres:

(d)(2)(i)(A)

* A full face piece pressure demand SCBA certified by NIOSH for a minimum service life of thirty minutes, or

(d)(2)(i)(B)

* A combination full face piece pressure demand supplied-air respirator (SAR) with auxiliary self-contained air supply.

(d)(2)(ii)

* Respirators provided only for escape from IDLH atmospheres shall be NIOSH-certified for escape from the atmosphere in which they will be used.

(d)(2)(iii)

* All oxygen-deficient atmospheres shall be considered IDHL. Exception: If the employer demonstrates that, under all foreseeable conditions, the oxygen concentration can be maintained within the ranges specified in Table II of this section, (i.e., for the altitudes set out in the table), then any atmosphere-supplying respirator may be used.

(d)(3)

* *Respirators for atmospheres that are not IDLH.*

(d)(3)(i)

* The employer shall provide a respirator that is adequate to protect the health of the employee and ensure compliance with all other OSHA statutory and regulatory requirements, under routine and reasonably foreseeable emergency situations.

(d)(3)(i)(A)

* *Assigned Protection Factors (APFs) [Reserved]*

(d)(3)(i)(B)

* *Maximum Use Concentration (MUC)* [Reserved]

(d)(3)(ii)

* The respirator selected shall be appropriate for the chemical state and physical form of the contaminant.

(d)(3)(iii)

* For protection against gases and vapors, the employer shall provide:

(d)(3)(iii)(A)

* An atmosphere-supplying respirator, or

(d)(3)(iii)(B)

* An air-purifying respirator, provided that:

(d)(3)(iii)(B)(1)

* (1) The respirator is equipped with an end-of service-life indicator (ESLI) certified by NIOSH for the contaminant; or

(d)(3)(iii)(B)(2)

* If there is no ESLI appropriate for conditions in the employer's workplace, the employer implements a change schedule for canisters and cartridges that is based on objective information or data that will ensure that canisters and cartridges are changed before the end of their service life. The employer shall describe in the respirator program the information and data relied upon and the basis for the canister and cartridge change schedule and the basis for reliance on the data.

(d)(3)(iv)

* For protection against particulates, the employer shall provide:

(d)(3)(iv)(A)

* An atmosphere-supplying respirator; or

(d)(3)(iv)(B)

* An air-purifying respirator equipped with a filter certified by NIOSH under 30 CFR part 11 as a high efficiency particulate air (HEPA) filter, or an air-purifying respirator equipped with a filter certified for particulates by NIOSH under 42 CFR part 84; or

(d)(3)(iv)(C)

* For contaminants consisting primarily of particles with mass median aerodynamic diameters (MMAD) of at least 2 micrometers, an air-purifying respirator equipped with any filter certified for particulates by NIOSH.

TABLE I.-- Assigned Protection Factors [Reserved]

TABLE II

Altitude (ft.)	Oxygen deficient Atmospheres (%O) for which the employer may rely on atmosphere supplying respirators
Less than 3,001.....	16.0 - 19.5
3,001 - 4,000.....	16.4 - 19.5
4,001 - 5,000.....	17.1 - 19.5
5,001 - 6,000.....	17.8 - 19.5
6,001 - 7,000.....	18.5 - 19.5
7,001 - 8,000*.....	19.3 - 19.5
* Above 8,000 feet the exception does not supply. Oxygen enriched breathing air must be supplied above 14,000 feet.	

...1910.134(e)

(e)
 * Medical evaluation. Using a respirator may place a physiological burden on employees that varies with the type of respirator worn, the job and workplace conditions in which the respirator is used, and the medical status of the employee. Accordingly, this paragraph specifies the minimum requirements for medical evaluation that employers must implement to determine the employee's ability to use a respirator.

(e)(1)
 * General. The employer shall provide a medical evaluation to determine the employee's ability to use a respirator, before the employee is fit tested or required to use the respirator in the workplace. The employer may discontinue an employee's medical evaluations when the employee is no longer required to use a respirator.

(e)(2)
 * Medical *evaluation procedures*.

(e)(2)(i)
 * The employer shall identify a physician or other licensed health care professional (PLHCP) to perform medical evaluations using a medical questionnaire or an initial medical examination that obtains the same information as the medical questionnaire.

(e)(2)(ii)
 * The medical evaluation shall obtain the information requested by the questionnaire in Sections 1 and 2, Part A of Appendix C of this section.

(e)(3)
 * *Follow-up medical examination*.

(e)(3)(i)

* The employer shall ensure that a follow-up medical examination is provided for an employee who gives a positive response to any question among questions 1 through 8 in Section 2, Part A of Appendix C or whose initial medical examination demonstrates the need for a follow-up medical examination.

(e)(3)(ii)

* The follow-up medical examination shall include any medical tests, consultations, or diagnostic procedures that the PLHCP deems necessary to make a final determination.

(e)(4)

* *Administration of the medical questionnaire and examinations.*

(e)(4)(i)

* The medical questionnaire and examinations shall be administered confidentially during the employee's normal working hours or at a time and place convenient to the employee. The medical questionnaire shall be administered in a manner that ensures that the employee understands its content.

(e)(4)(ii)

* The employer shall provide the employee with an opportunity to discuss the questionnaire and examination results with the PLHCP.

(e)(5)

* *Supplemental information for the PLHCP.*

(e)(5)(i)

* The following information must be provided to the PLHCP before the PLHCP makes a recommendation concerning an employee's ability to use a respirator;

(e)(5)(i)(A)

* (A) The type and weight of the respirator to be used by the employee;

(e)(5)(i)(B)

* The duration and frequency of respirator use (including use for rescue and escape);

(e)(5)(i)(C)

* The expected physical work effort.

(e)(5)(i)(D)

* Additional protective clothing and equipment to be worn; and

(e)(5)(i)(E)

* Temperature and humidity extremes that may be encountered.

(e)(5)(ii)

* Any supplemental information provided previously to the PLHCP regarding an employee need not be provided for a subsequent medical evaluation if the information and the PLHCP remain the same.

(e)(5)(iii)

* The employer shall provide the PLHCP with a copy of the written respiratory protection program

and a copy of this section.

*** Note to Paragraph (e)(5)(iii):** When the employer replaces a PLHCP, the employer must ensure that the new PLHCP obtains this information, either by providing the documents directly to the PLHCP or having the documents transferred from the former PLHCP to the new PLHCP. However, OSHA does not expect employers to have employees medically reevaluated solely because a new PLHCP has been selected.

(e)(6)

* Medical determination. In determining the employee's ability to use a respirator, the employer shall:

(e)(6)(i)

* Obtain a written recommendation regarding the employee's ability to use the respirator from the PLHCP. The recommendation shall provide only the following information:

(e)(6)(i)(A)

* Any limitations on respirator use related to the medical condition of the employee, or relating to the workplace conditions in which the respirator will be used, including whether or not the employee is medically able to use the respirator;

(e)(6)(i)(B)

* The need, if any, for follow-up medical evaluations; and

(e)(6)(i)(C)

* A statement that the PLHCP has provided the employee with a copy of the PLHCP's written recommendation.

(e)(6)(ii)

* If the respirator is a negative pressure respirator and the PLHCP finds a medical condition that may place the employee's health at increased risk if the respirator is used, the employer shall provide a PAPR if the PLHCP's medical evaluation finds that the employee can use such a respirator, if a subsequent medical evaluation finds that the employee is medically able to use a negative pressure respirator, then the employer is no longer required to provide a PAPR.

(e)(7)

* *Additional medical evaluations.* At a minimum, the employer shall provide additional medical evaluations that comply with the requirements of this section if:

(e)(7)(i)

* An employee reports medical signs or symptoms that are related to ability to use a respirator.

(e)(7)(ii)

* A PLHCP, supervisor, or the respirator program administrator informs the employer that an employee needs to be reevaluated;

(e)(7)(iii)

* Information from the respiratory protection program, including observations made during fit testing and program evaluation, indicates a need for employee reevaluation; or

(e)(7)(iv)

* A change occurs in workplace conditions (e.g., physical work effort, protective clothing, temperature) that may result in a substantial increase in the physiological burden placed on an employee.

(f)

* Fit testing. This paragraph requires that, before an employee may be required to use any respirator with a negative or positive pressure tight-fitting face piece, the employee must be fit tested with the same make, model, style, and size of respirator that will be used. This paragraph specifies the kinds of fit tests allowed, the procedures for conducting them, and how the results of the fit test must be used.

(f)(1)

* The employer shall ensure that employees using a tight-fitting face piece respirator pass an appropriate qualitative fit test (QLFT) or quantitative fit test (QNFT) as stated in this paragraph.

(f)(2)

* The employer shall ensure that an employee using a tight-fitting face piece respirator is fit tested prior to initial use of the respirator, whenever a different respirator face piece (size, style, model or make) is used, and at least annually thereafter.

(f)(3)

* The employer shall conduct an additional fit test whenever the employee reports, or the employer, PLHCP, supervisor, or program administrator makes visual observations of, changes in the employee's physical condition that could affect respirator fit. Such conditions include, but are not limited to, facial scarring, dental changes, cosmetic surgery, or an obvious changes in body weight.

(f)(4)

* If after passing a QLFT or QNFT, the employee subsequently notifies the employer, program administrator, supervisor, or PLHCP that the fit of the respirator is unacceptable, the employee shall be given a reasonable opportunity to select a different respirator face piece and to be re-tested.

...1910.134(f)(5)

(f)(5)

* The fit test shall be administered using an OSHA-accepted QLFT or QNFT protocol. The OSHA-accepted QLFT and QNFT protocols and procedures are contained in Appendix A of this section.

(f)(6)

* QLFT may only be used to fit test negative pressure air-purifying respirators that must achieve a fit factor of 100 or less.

(f)(7)

* If the fit factor , as determined through an OSHA-accepted QNFT protocol, is equal or greater than 100 for tight-fitting half facepieces, or equal to or greater than 500 for tight-fitting full face pieces the QNFT has been passed with that respirator.

(f)(8)

* Fit testing of tight-fitting atmosphere-supplying respirators and tight-fitting powered air-purifying respirators shall be accomplished by performing quantitative or qualitative fit testing in the negative pressure mode, regardless of the mode of operation (negative or positive pressure) that is used for respiratory protection.

(f)(1)(8)(i)

* Qualitative fit testing of these respirators shall be accomplished by temporarily converting the respirator user's actual face piece into a negative pressure respirator with appropriate filters, or by using an identical negative pressure air-purifying respirator face piece with the same sealing surfaces as a surrogate for the atmosphere-supplying or powered air-purifying respirator face piece.

(f)(1)(8)(ii)

* Quantitative fit testing of these respirators shall be accomplished by modifying the face piece to allow sampling inside the face piece in the breathing zone of the user, midway between the nose and mouth. This requirement shall be accomplished by installing a permanent sampling probe onto a surrogate face piece, or by using a sampling adapter designed to temporarily provide a means of sampling air from inside the face piece.

(f)(1)(8)(iii)

* Any modifications to the respirator face piece for fit testing shall be completely removed, and the face piece restored to NIOSH-approved configuration, before that face piece can be used in the workplace.

(g)

* *Use of respirators.* This paragraph requires employers to establish and implement procedures for the proper use of respirators. These requirements include prohibiting conditions that may result in face piece seal leakage, preventing employees from removing respirators in hazardous environments, taking actions to ensure continued effective respirator operation throughout the work shift, and establishing procedures for the use of respirators in IDLH atmospheres or in interior structural firefighting situations.

(g)(1)

* *Face piece seal protection.*

(g)(1)(i)

* The employer shall not permit respirators with tight-fitting face pieces to be worn by employees who have:

(g)(1)(i)(A)

* Facial hair that comes between the sealing surface of the face piece and the face or that interferes with valve function; or

(g)(1)(i)(B)

* Any condition that interferes with the face-to-face piece seal or valve function.

(g)(1)(ii)

* If an employee wears corrective glasses or goggles or other personal protective equipment, the employer shall ensure that such equipment is worn in a manner that does not interfere with the seal of the face piece to the face of the user.

(g)(1)(iii)

* For all tight-fitting respirators, the employer shall ensure that employees perform a user seal check each time they put on the respirator using the procedures in Appendix B-1 or procedures recommended by the respirator manufacturer that the employer demonstrates are as effective as those in Appendix B-1 of this section.

(g)(2)

* *Continuing respirator effectiveness.*

(g)(2)(i)

* Appropriate surveillance shall be maintained of work area conditions and degree of employee exposure or stress. When there is a change in work area conditions or degree of employee exposure or stress that may affect respirator effectiveness, the employer shall reevaluate the continued effectiveness of the respirator.

(g)(2)(ii)

* The employer shall ensure that employees leave the respirator use area:

..1910.134(g)(2)(ii)(A)

(g)(2)(ii)(A)

* To wash their faces and respirator face pieces as necessary to prevent eye or skin irritation associated with respirator use; or

(g)(2)(ii)(B)

* If they detect vapor or gas breakthrough, changes in breathing resistance, or leakage of the face piece; or

(g)(2)(ii)(C)

* To replace the respirator or the filter, cartridge, or canister elements.

(g)(2)(iii)

* If the employee detects vapor or gas breakthrough, changes in breathing resistance, or leakage of the face piece, the employer must replace or repair the respirator before allowing the employee to return to the work area.

(g)(3)

* *Procedures for IDHL atmospheres.* For all IDLH atmospheres, the employer shall ensure that:

(g)(3)(i)

* One employee or, when needed, more than one employee is located outside the IDLH atmosphere;

(g)(3)(ii)

* Visual, voice, or signal line communication is maintained between the employee(s) in the IDLH atmosphere and the employee(s) located outside the IDLH atmosphere;

(g)(3)(iii)

* The employee(s) located outside the IDLH atmosphere are trained and equipped to provide effective emergency rescue;

(g)(3)(iv)

* The employer or designee is notified before the employee(s) located outside the IDLH atmosphere enter the IDLH atmosphere to provide emergency rescue;

(g)(3)(v)

* The employer or designee authorized to do so by the employer, once notified, provides necessary assistance appropriate to the situation;

(g)(3)(vi)

* Employee(s) located outside the IDLH atmospheres are equipped with:

(g)(3)(vi)(A)

* Pressure demand or other positive pressure SCBA's, or a pressure demand or other positive pressure supplied-air respirator with auxiliary SCBA, and either

(g)(3)(vi)(B)

* Appropriate retrieval equipment for removing the employee(s) who enter(s) these hazardous atmospheres where retrieval equipment would contribute to the rescue of the employee(s) and would not increase the overall risk resulting from entry; or

(g)(3)(vi)(C)

* Equivalent means for rescue where retrieval equipment is not required under paragraph **(g)(3)(vi)(B)**.

(g)(4)

* *Procedures for interior structural firefighting.* In addition to the requirements set forth under paragraph **0 (g)(3)**, in interior structural fires, the employer shall ensure that:

(g)(4)(i)

* At least two employees enter the IDLH atmosphere and remain in visual or voice contact with one another at all times;

(g)(4)(ii)

* At least two employees are located outside the IDLH atmosphere; and

(g)(4)(iii)

* All employees engaged in interior structural firefighting use SCBA's

* **Note 1 to paragraph (g):** One of the two individuals located outside the IDLH atmosphere may be assigned to an additional role, such as incident commander in charge of the emergency or safety officer, so long as this individual is able to perform assistance or rescue activities without jeopardizing the safety or health of any firefighter working at the incident.

* **Note 2 to paragraph (g):** Nothing in this section is meant to preclude firefighters from performing emergency rescue activities before an entire team has assembled.

(h)

* **(h) Maintenance and care of respirators.** This paragraph requires the employer to provide for the cleaning and disinfecting, storage, inspection, and repair of respirators used by employees.

(h)(1)

* *Cleaning and disinfecting.* The employer shall provide each respirator user with a respirator that is clean, sanitary, and in good working order. The employer shall ensure that respirators are cleaned and disinfected using the procedures in Appendix B-2 of this section, or procedures recommended by the respirator manufacturer, provided that such procedures are of equivalent effectiveness. The respirators shall be cleaned and disinfected at the following intervals.

(h)(1)(i)

* Respirators issued for the exclusive use of an employee shall be cleaned and disinfected as often as necessary to be maintained in a sanitary condition;

(h)(1)(ii)

* Respirators issued to more than one employee shall be cleaned and disinfected before being worn by different individuals;

(h)(1)(iii)

* Respirators maintained for emergency use shall be cleaned and disinfected after each use; and

(h)(1)(iv)

* Respirators used in fit testing and training shall be cleaned and disinfected after every each use.

(h)(2)

* *Storage.* The employer shall ensure that respirators are stored as follows:

(h)(2)(i)

* All respirators shall be stored to protect them from damage, contamination, dust, sunlight, extreme temperatures, excessive moisture, and damaging chemicals, and they shall be packed or stored to prevent deformation of the face piece and exhalation valve.

(h)(2)(ii)

* In addition to the requirements of paragraph **(h)(2)(i)** of this section, emergency respirators shall be:

(h)(2)(ii)(A)

* Kept accessible to the work area;

(h)(2)(ii)(B)

* Stored in compartments or in covers that are clearly marked as containing emergency respirators; and

(h)(2)(ii)(C)

* Stored in accordance with any applicable manufacturer instructions.

.. 1910.134(h)(3)

(h)(3)

* *Inspection.*

(h)(3)(i)

* The employer shall ensure that respirators are inspected as follows:

(h)(3)(i)(A)

* All respirators used in routine situations shall be inspected before each use and during cleaning;

(h)(3)(i)(B)

* All respirators maintained for use in emergency situations shall be inspected at least monthly and in accordance with the manufacturer's recommendations, and shall be checked for proper function before and after each use; and

(h)(3)(i)(C)

* Emergency escape-only respirators shall be inspected before being carried into the workplace for use.

(h)(3)(ii)

* The employer shall ensure that respirator inspections include the following:

(h)(3)(ii)(A)

* A check of respirator function, tightness of connections, and the condition of the various parts including, but not limited to, the face piece, head straps, valves, connecting tube, and cartridges, canisters or filters; and

(h)(3)(ii)(B)

* A check of elastomeric parts for pliability and signs of deterioration.

(h)(3)(iii)

* In addition to the requirements of paragraphs **(h)(3)(i)** and **(ii)** of this section, self-contained breathing apparatus shall be inspected monthly. Air and oxygen cylinders shall be maintained in a fully charged state and shall be recharged when the pressure falls to 90% of the manufacturer's recommended pressure level. The employer shall determine that the regulator and warning devices function properly.

(h)(3)(iv)

* For respirators maintained for emergency use, the employer shall:

(h)(3)(iv)(A)

* Certify the respirator by documenting the date the inspection was performed, the name (or signature) of the person who made the inspection, the findings, required remedial action, and a serial number or other means of identifying the inspected respirator; and

(B) Provide this information on a tag or label that is attached to the storage compartment for the respirator, is kept with the respirator, or is included in inspection reports stored as paper or electronic files. This information shall be maintained until replaced following a subsequent certification.

(h)(4)

* *Repairs.* The employer shall ensure that respirators that fail an inspection or are otherwise found to be defective are removed from service, and are discarded or repaired or adjusted in accordance with the following procedures:

(h)(4)(i)

* Repairs or adjustments to respirators are to be made only by persons appropriately trained to

perform such operations and shall use only the respirator manufacturer's NIOSH-approved parts designed for the respirator.

(h)(4)(ii)

* Repairs shall be made according to the manufacturer's recommendations and specifications for the type and extent of repairs to be performed; and

(h)(4)(iii)

* Reducing and admission valves, regulators, and alarms shall be adjusted or repaired only by the manufacturer or a technician trained by the manufacturer.

(i)

* *Breathing air quality and use.* This paragraph requires the employer to provide employees using atmosphere-supplying respirators (supplied air and SCBA) with breathing gases of high purity.

(i)(1)

* The employer shall ensure that compressed air, compressed oxygen, liquid air, and liquid oxygen used for respiration accords with the following specifications:

(i)(1)(i)

* Compressed and liquid oxygen shall meet the United States Pharmacopoeia requirements for medical or breathing oxygen; and

..1910.134(i)(1)(ii)

(i)(1)(ii)

* Compressed breathing air shall meet at least the requirements for Grade D breathing air described in ANSI/Compressed Gas Association Commodity Specification for Air, G-7.1-1989, to include:

(i)(1)(ii)(A)

* Oxygen content (v/v) of 19.5 - 23.5%;

(i)(1)(ii)(B)

* Hydrocarbon (condensed) content of 5 milligrams per cubic meter of air or less;

(i)(1)(ii)(C)

* Carbon monoxide (CO) content of 10ppm or less;

(i)(1)(ii)(D)

* Carbon dioxide content of 1,000 ppm or less; and

(i)(1)(ii)(E)

* Lack of noticeable odor.

(i)(2)

* The employer shall ensure that compressed oxygen is not used in atmosphere-supplying respirators that have previously used compressed air.

(i)(3)

* The employer shall ensure that oxygen concentrations greater than 23.5% are used only in equipment designed for oxygen service distribution.

(i)(4)

* The employer shall ensure that cylinders used to supply breathing air to respirators meet the following requirements:

(i)(4)(i)

* Cylinders are tested and maintained as prescribed in the Shipping Container Specification Regulations of the Department of Transportation (49CFR part 173 and part 178),

(i)(4)(ii)

* Cylinders of purchased breathing air have a certificate of analysis from the supplier that the breathing air meets the requirements for Grade D breathing air; and

(i)(4)(iii)

* The moisture content in the cylinder does not exceed a dew point of -50 degrees F (-45.6 deg C) at 1 atmosphere pressure.

(i)(5)

* The employer shall ensure that compressors used to supply breathing air to respirators are constructed and situated so as to:

(i)(5)(i)

* Prevent entry of contaminated air into the air supply system;

(i)(5)(ii)

* Minimize moisture content so that the dew point at 1 atmosphere pressure is 10 degrees F (5.56 deg. C) below the ambient temperature;

(i)(5)(iii)

* Have suitable in-line air-purifying sorbent beds and filters to further ensure breathing air quality. Sorbent beds and filters shall be maintained and replaced or refurbished periodically following the manufacturer's instructions.

(i)(5)(iv)

* Have a tag containing the most recent change date and the signature of the person authorized by the employer to perform the change. The tag shall be maintained at the compressor.

(i)(6)

* For compressors that are not oil-lubricated, the employer shall ensure that carbon monoxide levels in the breathing air do not exceed 10 ppm.

(i)(7)

* For oil-lubricated compressors, the employer shall use a high-temperature or carbon monoxide alarm, or both, to monitor carbon monoxide levels. If only high-temperature alarms are used, the air supply shall be monitored at intervals sufficient to prevent carbon monoxide in the breathing air from exceeding 10ppm.

(i)(8)

* The employer shall ensure that breathing air couplings are incompatible with outlets for non-respirable worksite air or other gas systems. No asphyxiating substance shall be introduced into breathing air lines.

(i)(9)

* The employer shall use breathing gas containers marked in accordance with the NIOSH respirator certification standard, 42 CFR part 84.

(j)

* *Identification of filters, cartridges, and canisters.* The employer shall ensure that all filters, cartridges, and canisters used in the workplace are labeled and color coded with the NIOSH approval label and that the label is not removed and remains legible.

(k)

* *Training and information.* This paragraph requires the employer to provide effective training to employees who are required to use respirators. The training must be comprehensive, understandable, and recur annually, and more often if necessary. This paragraph also requires the employer to provide the basic information on respirators in Appendix D of this section to employees who wear respirators when not required by this section or by the employer to do so.

(k)(1)

* The employer shall ensure that each employee can demonstrate knowledge of at least the following:

..1910.134(k)(1)(i)

(k)(1)(i)

* Why the respirator is necessary and how improper fit, usage, or maintenance can compromise the protective effect of the respirator;

(k)(1)(ii)

* What the limitations and capabilities of the respirator are;

(k)(1)(iii)

* How to use the respirator effectively in emergency situations, including situations in which the respirator malfunctions;

(k)(1)(iv)

* How to inspect, put on and remove, use, and check the seals of the respirator;

(k)(1)(v)

* What the procedures are for maintenance and storage of the respirator;

(k)(1)(vi)

* How to recognize medical signs and symptoms that may limit or prevent the effective use of respirators; and

(k)(1)(vii)

* The general requirements of this section.

(k)(2)

* The training shall be conducted in a manner that is understandable to the employee.

(k)(3)

* The employer shall provide the training prior to requiring the employee to use a respirator in the workplace.

(k)(4)

* An employer who is able to demonstrate that a new employee has received training within the last 12 months that addresses the elements specified in paragraph(k)(1)(i) through (vii) is not required to repeat such training provided that, as required by paragraph (k)(1), the employee can demonstrate knowledge of those element(s). Previous training not repeated initially by the employer must be provided no later than 12 months from the date of the previous training.

(k)(5)

* Retraining shall be administered annually, and when the following situations occur:

(k)(5)(i)

* Changes in the workplace or the type of respirator render previous training obsolete;

(k)(5)(ii)

* Inadequacies in the employee's knowledge or use of the respirator indicate that the employee has not retained the requisite understanding or skill; or

(k)(5)(iii)

* Any other situation arises in which retraining appears necessary to ensure safe respirator use.

(k)(6)

* The basic advisory information on respirators, as presented in Appendix D of this section, shall be provided by the employer in any written or oral format, to employees who wear respirators when such use is not required by this section or by the employer.

(l)

* *Program evaluation.* This section requires the employer to conduct evaluations of the workplace to ensure that the written respiratory protection program is being properly implemented, and to consult employees to ensure that they are using the respirators properly.

(l)(1)

* The employer shall conduct evaluations of the workplace as necessary to ensure that the provisions of the current written program are being effectively implemented and that it continues to be effective.

(l)(2)

* The employer shall regularly consult employees required to use respirators to assess the employees' views on program effectiveness and to identify any problems. Any problems that are identified during this assessment shall be corrected. Factors to be assessed include, but are not limited to:

.. 1910.134(l)(2)(i)

(l)(2)(i)

* Respirator fit (including the ability to use the respirator without interfering with effective workplace performance);

(I)(2)(ii)

* Appropriate respirator selection for the hazards to which the employee is exposed;

(I)(2)(iii)

* Proper respirator use under the workplace conditions the employee encounters; and

(I)(2)(iv)

* Proper respirator maintenance.

(m)

* *Recordkeeping*. This section requires the employer to establish and retain written information regarding medical evaluations, fit testing, and the respirator program. This information will facilitate employee involvement in the respirator program, assist the employer in auditing the adequacy of the program, and provide a record for compliance determinations by OSHA.

.. 1910.134(m)(1)

(m)(1)

* *Medical evaluation*. Records of medical evaluations required by this section must be retained and made available in accordance with 29 CFR 1910.1020.

(m)(2)

* *Fit testing*.

(m)(2)(i)

* The employer shall establish a record of the qualitative and quantitative fit tests administered to an employee including:

(m)(2)(i)(A)

* The name or identification of the employee tested;

(m)(2)(i)(B)

* Type of fit test performed;

(m)(2)(i)(C)

* Specific make, model, style, and size of respirator tested;

(m)(2)(i)(D)

* Date of test, and

(m)(2)(i)(E)

* The pass/fail results for QLFTs or the fit factor and strip chart recording or other recording of the test results for QNFTs.

(m)(2)(ii)

* Fit test records shall be retained for respirator users until the next fit test is administered.

(m)(3)

* A written copy of the current respirator program shall be retained by the employer.

(m)(4)

* Written materials required to be retained under this paragraph shall be made available upon

request to affected employees and to the Assistant Secretary or designee for examination and copying.

(n)

* *Dates*

(n)(1)

* *Effective date.* This section is effective April 8, 1998. The obligations imposed by this section commence on the effective date unless otherwise noted in this paragraph. Compliance with obligations that do not commence on the effective date shall occur no later than the applicable start-up date.

(n)(2)

* *Compliance dates.* All obligations of this section commence on the effective date except as follows:

..1910.134(n)(2)(i)

(n)(2)(i)

* The determination that respirator use is required (paragraph (a)) shall be completed no later than September 8, 1998.

(n) (2) (ii)

* Compliance with provisions of this section for all other provisions shall be completed no later than October 8, 1998

(n)(3)

* The provisions of 29 CFR 1910.134 and 29CFR 1926.103, contained in the 29 CFR parts 1900 to 1910.99 and the 29 CFR part 1926 editions, revised as of July 1, 1997, are in effect and enforceable until October 5, 1998, or during any administrative or judicial stay of the provisions of this section.

(n)(4)

* *Existing Respiratory Protection Programs.* If, in the 12 month period preceding April 8, 1998, the employer has conducted annual respirator training, fit testing, respirator program evaluation, or medical evaluations, the employer may use the results of those activities to comply with the corresponding provisions of this section, providing that these activities were conducted in a manner that meets the requirements of this section.

..1910.134(o)

(o)

* *Appendices.*

(o)(1)

* Compliance with Appendix A, Appendix B-1, Appendix B-2, and Appendix C of this section is mandatory.

(o)(2)

* Appendix D of this section is non-mandatory and is not intended to create any additional obligations not otherwise imposed or to detract from any existing obligations.

* **[63FR 1152, Jan. 8, 1998; 63 FR 20098, April 23, 1998]**

RESPIRATORY PROTECTION PROGRAM

1. Written standard operating procedures governing the selection and use of respirators shall be established.
2. Respirators shall be selected on the basis of hazards to which the worker is exposed.
3. The user shall be instructed and trained in the proper use of respirators and their limitations.
4. Where practicable, the respirators should be assigned to individual workers for their exclusive use.
5. Respirators shall be regularly cleaned and disinfected. Those issued for the exclusive use of one worker should be cleaned after each day's use, or more often if necessary. Those used by more than one worker shall be thoroughly cleaned and disinfected after each use.
6. Respirators shall be stored in a convenient, clean, and sanitary location.
7. Respirators used routinely shall be inspected during cleaning. Worn or deteriorated parts shall be replaced. Respirators for emergency use such as self-contained devices shall be thoroughly inspected at least once a month and after each use.
8. Appropriated surveillance of work area conditions and degree of employee exposure of stress shall be maintained.
9. There shall be regular inspection and evaluation to determine the continued effectiveness of the program.
10. Persons should not be assigned to tasks requiring use of respirators unless it has been determined that they are physically able to perform the work and use the equipment. The local physician shall determine what health and physical conditions are pertinent. The respirator user's medical status should be reviewed periodically (for instance, annually).
11. Approved or accepted respirators shall be issued when they are available. The respirator furnished shall provide adequate respiratory protection against a particular hazard for which it is designed in accordance with standards established by competent authorities.

**A RESPIRATORY PROTECTION PROGRAM MUST
BE IMPLEMENTED PER OSHA 29CFR 1910.134.**

OPTI-FIT FULLFACE WARRANTY AND LIMITATION OF LIABILITY

LIMITED WARRANTY: SAS Safety warrants this product to be free from defects in materials and workmanship for 3 year from the date of purchase. During this period, SAS Safety will repair or replace defective parts, at SAS Safety's option. Freight charges to and from the SAS Safety factory shall be paid by the purchaser (owner).

EXCLUSIONS: NOT WITHSTANDING ANY CONTRARY TERM IN THE PURCHASER'S PURCHASE ORDER OR OTHERWISE, THE ONLY WARRANTY EXTENDED BY SAS SAFETY IS THE EXPRESSED LIMITED WARRANTY DEFINED ABOVE. THIS WARRANTY IS EXCLUSIVE AND IN LIEU OF ANY IMPLIED WARRANTY OR MERCHANTABILITY, OR FITNESS FOR A PARTICULAR PURPOSE.

CONDITIONS: To maintain this warranty this product must be used, maintained, and inspected as prescribed in the owner's instruction manual, including prompt replacement or repair of defective parts and such other necessary maintenance and repair as may be required. Normal wear and tear, and parts damaged by abuse, misuse, negligence, or accidents are specifically excluded from this warranty.

LIMITATIONS OF LIABILITY: No other oral warranties, representations, or guarantees of any kind have been made by SAS Safety, its distributors, or the agents of either of them, that in any way alter the terms of this warranty. **EXCEPT AS HEREIN PROVIDED, SAS SAFETY SHALL HAVE NO LIABILITY FOR ANY LOSS OR DAMAGE WHETHER DIRECT, INDIRECT, INCIDENTAL, OR CONSEQUENTIAL, TO ANY PURCHASER OR USER OF THIS PRODUCT ARISING FROM THE SALE, USE, OR OPERATION OF THIS PRODUCT.**

WARNING: The failure to use and maintain this equipment in strict conformance with the applicable instruction manual may result in serious personal injury, and its use in any manner that is not expressly authorized pursuant to the applicable instruction manual may result in severe adverse impacts to human health.

GAST Warranty Information

Gast finished products, when properly installed and operated under normal conditions of use, are warranted by Gast to be free from defects in material and workmanship for a period of twelve (12) months from the date of purchase from Gast or an authorized Gast Representative or Distributor. In order to obtain performance under this warranty, the buyer must promptly (in no event later than thirty (30) days after discovery of the defect) give written notice of the defect to Gast Manufacturing, Inc, PO Box 97, Benton Harbor Michigan USA 49023-0097 or an authorized Service Center (unless specifically agreed upon in writing signed by both parties or specified in writing as part of a Gast OEM Quotation). Buyer is responsible for freight charges both to and from Gast in all cases.

This warranty does not apply to electric motors, electrical controls, and gasoline engines not supplied by Gast. Gast's warranties also do not extend to any goods or parts which have been subjected to misuse, lack of maintenance, neglect, damage by accident or transit damage.

THIS EXPRESS WARRANTY EXCLUDES ALL OTHER WARRANTIES OR REPRESENTATIONS EXPRESSED OR IMPLIED BY ANY LITERATURE, DATA, OR PERSON. GAST'S MAXIMUM LIABILITY UNDER THIS EXCLUSIVE REMEDY SHALL NEVER EXCEED THE COST OF THE SUBJECT PRODUCT AND GAST RESERVES THE RIGHT, AT ITS SOLE DISCRETION, TO REFUND THE PURCHASE PRICE IN LIEU OF REPAIR OR REPLACEMENT.

GAST WILL NOT BE RESPONSIBLE OR LIABLE FOR INDIRECT OR CONSEQUENTIAL DAMAGES OF ANY KIND, however arising, including but not limited to those for use of any products, loss of time, inconvenience, lost profit, labor charges, or other incidental or consequential damages with respect to persons, business, or property, whether as a result of breach of warranty, negligence or otherwise. Notwithstanding any other provision of this warranty, BUYER'S REMEDY AGAINST GAST FOR GOODS SUPPLIED OR FOR NON-DELIVERED GOODS OR FAILURE TO FURNISH GOODS, WHETHER OR NOT BASED ON NEGLIGENCE, STRICT LIABILITY OR BREACH OF EXPRESS OR IMPLIED WARRANTY, IS LIMITED SOLELY, AT GAST'S OPTION, TO REPLACEMENT OF OR CURE OF SUCH NONCONFORMING OR NON-DELIVERED GOODS OR RETURN OF THE PURCHASE PRICE FOR SUCH GOODS AND IN NO EVENT SHALL EXCEED THE PRICE OR CHARGE FOR SUCH GOODS. GAST EXPRESSLY DISCLAIMS ANY WARRANTY OF MERCHANTABILITY OR FITNESS FOR A PARTICULAR USE OR PURPOSE WITH RESPECT TO THE GOODS SOLD. THERE ARE NO WARRANTIES WHICH EXTEND BEYOND THE DESCRIPTIONS SET FORTH IN THIS WARRANTY, notwithstanding any knowledge of Gast regarding the use or uses intended to be made of goods, proposed changes or additions to goods, or any assistance or suggestions that may have been made by Gast personnel.

Unauthorized extensions of warranties by the customer shall remain the customer's responsibility.

CUSTOMER IS RESPONSIBLE FOR DETERMINING THE SUITABILITY OF GAST PRODUCTS FOR CUSTOMER'S USE OR RESALE, OR FOR INCORPORATING THEM INTO OBJECTS OR APPLICATIONS WHICH CUSTOMER DESIGNS, ASSEMBLES, CONSTRUCTS OR MANUFACTURES.

This warranty can be modified only by authorized Gast personnel by signing a specific, written description of any modifications.

