

Sunbeam

BBQ Grill

2400W Variable Heat Control

Instruction Booklet

HG055A

Please read these instructions carefully
and retain for future reference.



Contents

Sunbeam safety precautions	1
Features of your Sunbeam BBQ Grill	2
Dupont Teflon® Platinum Pro™	4
How to use your Sunbeam BBQ Grill	5
Tips to cooking great steaks	6
Tips to cooking great fish fillets	6
Care and cleaning	7
Recipes	8

Important instructions – retain for future use.

تأكد من تفهم احتياطات السلامة المذكورة اعلاه

請務必理解上述的安全預防措施。

Assurez-vous que les précautions ci-dessus relatives à la sécurité sont bien comprises

Versichern Sie sich, dass die obenstehenden Sicherheitsmaßnahmen verstanden werden

Βεβαιώστε πως οι παραπάνω προφυλάξεις ασφαλείας γίνονται κατανοητές

Pastikan bahwa tindakan-tindakan keselamatan seperti di atas dimengerti anda

Accertatevi che le suddette norme di sicurezza siano comprese a dovere

上記の注意事項をよくお読みになり、安全を御確認ください

Уверете се дека погоре споменатите мерки на претпазливост се добро разбрани

Asegúrese de que las precauciones de seguridad precedentes sean bien comprendidas

کاری یکنید که احتیاطهای بالا حتماً درک بشوند

ต้องแน่ใจว่า ข้อควรระวังเรื่องความปลอดภัยข้างต้น เป็นที่เข้าใจกันดี

Yukarda belirlilen güvenlik önlemlerinin anlaşıldığından emin olunuz

Xin kiểm chắc rằng những biện pháp làm an toàn kể trên được hiểu rõ

Sunbeam's Safety Precautions

SAFETY PRECAUTIONS FOR YOUR SUNBEAM BBQ GRILL.

- Use well away from walls and curtains.
- Do not immerse the control probe in water or any other liquid.
- The BBQ grill must only be used with the control probe provided.
- Adequate ventilation or an exhaust fan is recommended.
- Do not leave plastic utensils in contact with appliance while cooking.
- Only use appliance fully assembled with all parts correctly in place, as specified in this instruction book.
- The appliance is not intended to be operated by means of an external timer or separate remote control system.

Sunbeam is very safety conscious when designing and manufacturing consumer products, but it is essential that the product user also exercise care when using an electrical appliance. Listed below are precautions which are essential for the safe use of an electrical appliance:

- Read carefully and save all the instructions provided with an appliance.
- Always turn the power off at the power outlet before you insert or remove a plug. Remove by grasping the plug - do not pull on the cord.
- Turn the power off and remove the plug when the appliance is not in use and before cleaning.
- Do not use your appliance with an extension cord unless this cord has been checked and tested by a qualified technician or service person.
- Always use your appliance from a power outlet of the voltage (A.C. only) marked on the appliance.
- This appliance is not intended for use by persons (including children) with reduced physical, sensory or mental capabilities, or lack of experience and knowledge, unless they have been given supervision or instruction concerning use of the appliance by a person responsible for their safety.
- Children should be supervised to ensure that they do not play with the appliance.
- The temperature of accessible surfaces may be high when the appliance is operating.
- Never leave an appliance unattended while in use.
- Do not use an appliance for any purpose other than its intended use.
- Do not place an appliance on or near a hot gas flame, electric element or on a heated oven.
- Do not place on top of any other appliance.
- Do not let the power cord of an appliance hang over the edge of a table or bench top or touch any hot surface.
- Do not operate any electrical appliance with a damaged cord or after the appliance has been damaged in any manner. If damage is suspected, return the appliance to the nearest Sunbeam Appointed Service Centre for examination, repair or adjustment.
- For additional protection, Sunbeam recommend the use of a residual current device (RCD) with a tripping current not exceeding 30mA in the electrical circuit supplying power to your appliances.
- Do not immerse the appliance in water or any other liquid unless recommended.
- Appliances are not intended to be operated by means of an external timer or separate remote control system.
- This appliance is intended to be used in household and similar applications such as: staff kitchen areas in shops, offices and other working environments; farm houses; by clients in hotels, motels and other residential type environments; bed and breakfast type environments.

If you have any concerns regarding the performance and use of your appliance, please visit www.sunbeam.com.au or contact the Sunbeam Consumer Service Line.

Ensure the above safety precautions are understood.

Features of your Sunbeam BBQ Grill

Detachable splatter shield

Prevents fats and juices from splashing onto the bench surface.

Cool touch handles

Fit securely into the moulded base for easy carrying.

Grill hotplate

Seals in the juices and flavours of your favourite foods, and allows fats to drip through the grill bars for healthy, fat free cooking.

Powerful 2400 watt element

The element is cast into the hotplate to ensure fast heat-up, even heat distribution and long element life.

Removable drip tray

Collects fats and juices during cooking. Dishwasher-safe for easy cleaning.

Moulded base

Supports the hot plate and drip tray. Made from durable, heat resistant Nylon.

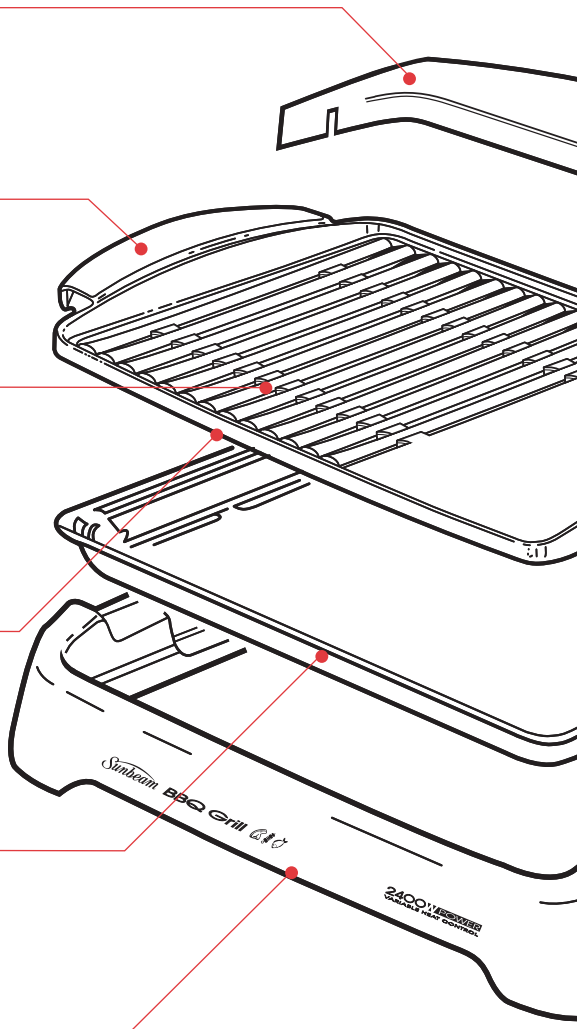

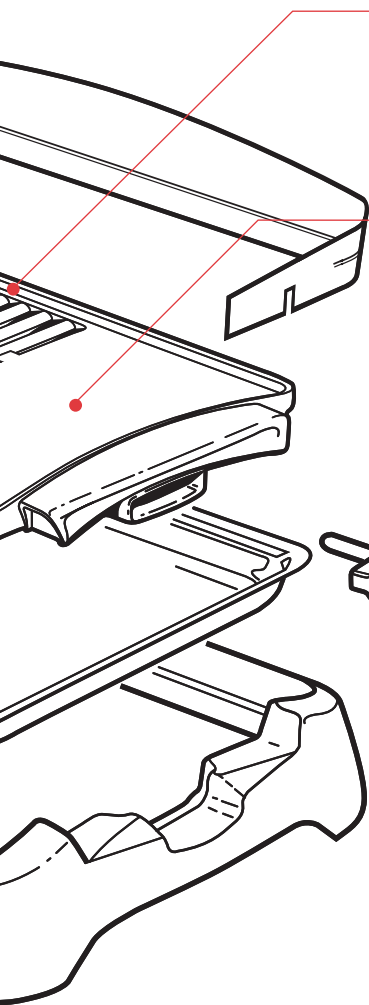

Dupont Teflon® Platinum with ScratchGuard™ non-stick coating

Safe to use with metal utensils. Up to 10 times more scratch-resistant than other non-stick coatings.

Flat hotplate

Ideal for cooking a variety of foods including eggs, bacon, onions, mushrooms and tomatoes.

15 heat settings plus SuperSear

15 heat settings provide perfect control in specific cooking tasks. The SuperSear setting is specially designed to produce quick, powerful heat for searing and sealing in juices.

Settings 1-5: Low heat settings – keep warm

Settings 6-10: Medium heat settings – to cook food thoroughly

Settings 11-15: High heat settings – for fast cooking and sealing in juices

SuperSear: Super heat setting – for searing and quick browning

Thermostatically controlled removable probe

The control probe is thermostatically controlled to ensure constant temperature, and is removable for portability and easy cleaning.

DuPont Teflon® Platinum Pro™



Your Sunbeam BBQ Grill features a special scratch and abrasive-resistant non-stick cooking coating that makes it safe to use metal utensils when cooking. Teflon® Platinum Pro™ – Professional Use is DuPont's toughest non-stick coating to date – up to 10 times more scratch resistant than single layer non-stick coatings.*

DuPont is the world leader in non-stick coatings and today more than 2 billion households have Teflon® non-stick coated cookware.

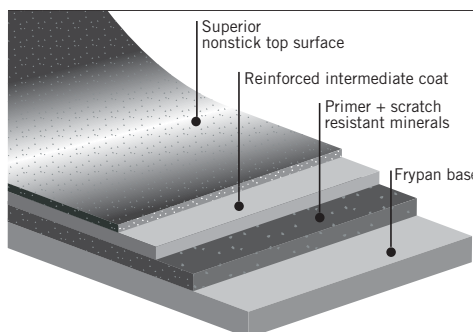

Teflon® Platinum Pro™ – 3 layer scratch resistant coating

Teflon® Platinum Pro™ is a premium 3 layer non-stick coating. It features special scratch resistant minerals causing metal utensils to slide over these particles without damaging the Teflon® matrix. This preserves the release properties of the non-stick coating and the life of the frypan.

The result is a non-stick coating that can be treated like ordinary cookware, enabling the use of metal utensils. However, Sunbeam recommends that care is taken with the non-stick coating when using metal utensils.

Do not use sharp objects or cut food inside the frypan. Damage caused to your frypan as a result of misuse of metal utensils will void your warranty.

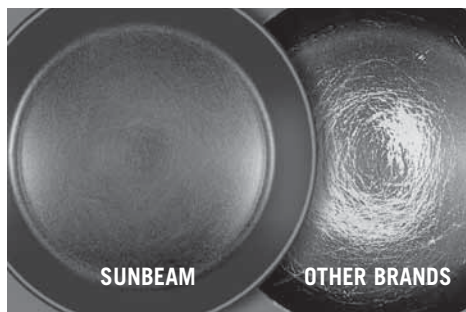

Results from DuPont's 'In-house Cooking Abuse Test'

*The images shown here and performance claims are based upon the Dupont In-house Cooking Abuse Test used to evaluate scratch resistance and release properties of non-stick coatings.

How to use your Sunbeam BBQ Grill

Before first use

Remove sticker from hotplate. Wash the hotplate and drip tray in warm soapy water using a mild household detergent. Dry hotplate and drip tray thoroughly.

Place drip tray into base. For easy cleaning line the drip tray with aluminium foil. This will collect the fats and juices.

Position the hotplate over base and drip tray.

For better non-stick performance, “season” the cooking surface of the hotplate by applying a thin coat of cooking oil and rubbing in with paper towelling before each use.

IMPORTANT: Charcoal or similar combustible fuels must not be used with this appliance.

Using your BBQ Grill

1. Insert the control probe fully into the socket of the hotplate.
2. Plug the cord into a 230/240V power outlet and turn the power ON.
3. Set the control probe dial to the desired heat setting, or the heat setting recommended in the recipe. When the thermostat light on the control probe switches off, the desired cooking temperature has been reached and the BBQ Grill is ready to use.

NOTE 1: The thermostat light on the control probe indicates the BBQ Grill is heating. This light will remain ON until the set temperature has been reached and then will cycle ON and OFF throughout cooking. This will ensure that the BBQ Grill always maintains the selected temperature.

The preheat time will depend on the heat setting selected. If a high heat setting is selected, a longer preheat time is required.

NOTE 2: When barbecuing on high heat settings, the BBQ Grill will generate smoke. Selecting a lower setting will reduce smoke. Adequate ventilation is recommended.

Using the splatter shield

To attach the splatter shield to your BBQ Grill, position the shield on the hotplate so that the slots in the shield are resting securely over the ribs at either end of the hotplate, as shown in Figure 1. The splatter shield simply lifts off for easy cleaning and storage.

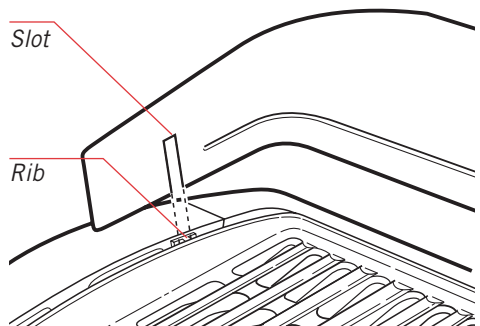

Figure 1

Tips to cooking great steaks

- Ensure that the BBQ Grill has been preheated on SuperSear for 10 minutes or until the light on the control probe has switched off.
 - Rub a small amount of oil onto both sides of the steak. Place steak onto the hot grill plate. The time taken to cook a steak will depend on the thickness of the steak. A thin steak will not take long at all.
 - Only turn steaks once. Turning several times or pressing down with tongs will only dry the steak out.
 - To cook a rare steak, cook for 2-3 minutes, depending on thickness, turn once and cook the other side for a further 2-3 minutes. The steak will be very soft to touch.
 - To cook a medium steak, cook for 4-6 minutes. The juices on the top of the steak will start to pool. Turn steak over and cook for a further 4-6 minutes. The steak will be tender to touch but not too soft.
 - To cook a well done steak, cook for 7-9 minutes, the juices will pool on the top of the steak and the colour of the steak will change up the sides of the steak the entire way. Turn steak over once and cook until the steak feel quite firm to touch.
 - Remove steaks from BBQ Grill and rest, covered, for a few minutes before serving.
-

Tips to cooking great fish fillets

- Ensure that the BBQ Grill has been preheated on SuperSear for 10 minutes or until the light on the control probe has switched off.
- Lightly coat the fillets in a little oil and season with salt and pepper, if desired.
- The time taken to cook a fish fillet will depend greatly on the thickness of the fillet.
- Most fish fillets are cooked until they are just cooked through. Although fish such as tuna or salmon can be cooked so that it is still medium to rare on the inside.
- Place fillets onto the hot grill. Do not attempt to move the fillets for at least a few minutes; this will only break up the fillet. Once the fish has formed a crust on the bottom and the colour of the fillets has started to change on the sides you can turn it over.
- Using a non-stick spatula, carefully turn the fish over. Only turn once. Cook the fish until it is just cooked through, the fish will still cook slightly once removed from the grill.
- A good way to tell if your fish is cooked through is to place a small, thin knife into the thickest part of the fish. If the knife feels warm to touch then the fish is cooked. If it is cool then cook for a little longer. The colour of the fillet will have turned from being transparent to an opaque colour.

Care and Cleaning

Do not leave plastic utensils in contact with hotplate while cooking

Before cleaning turn the power off, then remove the plug from the outlet and the control probe from the socket of the BBQ Grill.

DuPont Teflon® Platinum non-stick coating

Your BBQ Grill features a special scratch and abrasive-resistant non-stick coating that makes it safe to use metal utensils when cooking.

Regardless of this fact Sunbeam recommends that care is taken with the non-stick coating particularly when using metal utensils.

Do not use sharp objects or cut food on top of the BBQ Grill

When cleaning the non-stick coating do not use metal or other abrasive scourers. After cleaning, dry the BBQ Grill and lid thoroughly with a soft cloth before storing.

Always turn the power off and remove the plug from the power point before cleaning. Remove the control probe from the socket of the BBQ Grill.

Control probe

If cleaning is necessary, wipe over with a damp cloth.

Do not immerse the control probe in water or any other liquid.

NEVER use the BBQ Grill control probe in any other Sunbeam appliance.

Storage

Store the probe carefully in a safe place. Do not knock or drop it as this can damage the probe. If damage is suspected, return the control probe to your nearest Sunbeam Service Centre for inspection. Refer to the Service Centre listings.

Hotplate, drip tray and splatter shield

The element in the hotplate is totally sealed, so it is safe to fully immerse in water. Wash the hotplate, drip tray and splatter shield in warm soapy water using a mild household detergent and a soft washing sponge.

A bottle brush may be used to clean between the hotplate grill bars.

The hotplate, drip tray and splatter shield are also dishwasher safe.

Moulded base

The base can be wiped over with a damp cloth or washed in warm soapy water using a mild household detergent and a soft washing sponge.

Do not place the moulded base in a dishwasher.

Do not use abrasives or metal scourers as they may scratch the base.

Storage

Always dry and assemble the BBQ Grill before storing. Ensure the drip tray and hotplate are correctly positioned.

Store the assembled BBQ Grill on a flat surface on your benchtop or cupboard.

IMPORTANT: Before inserting control probe in probe socket, ensure the interior of the socket is fully dry. To do this, wipe interior of socket with a dry cloth or shake out excess water vigorously.

Recipes

Baby Octopus

1 kg cleaned baby octopus
2 cloves garlic, crushed
¼ cup olive oil
⅓ cup balsamic vinegar
½ cup basil leaves, shredded
2 tablespoons brown sugar
sea salt and freshly ground black pepper

1. Cut octopus in half if they are large. Ensure that the beaks have been removed from the centre.
2. Place octopus in a large bowl and cover with boiling water. Allow to stand for 2 minutes then drain well.
3. Place octopus in a clean bowl with remaining ingredients; refrigerate overnight.
4. Preheat BBQ Grill on SuperSear. Drain octopus then place on hot grill. Cook for about 5 minutes or until they have changed to a golden colour.

Barbecue Chilli Lime Prawns

1 kg green prawns
1 teaspoon palm sugar
2 tablespoons peanut oil
¼ cup lime juice
2 red chillies, seeded and finely chopped
1 tablespoon sweet chilli sauce
2 tablespoons chopped fresh coriander

1. Preheat BBQ Grill on SuperSear.
2. Shell and devein prawns leaving tails intact. Combine prawns and remaining ingredients in a bowl and refrigerate for 1 hour.
3. Cook prawns for about 3 minutes on each side or until just cooked through.
4. Serve with steamed jasmine rice.

Serves 4

Beef Skewers with Satay Dipping Sauce

1 kg rump steak
2 tablespoons soy sauce
1 teaspoon sesame oil
1 clove garlic, crushed
1 tablespoon grated fresh ginger
24 small wooden skewers

Satay sauce

1 cup crunchy light peanut butter
½ cup water
1 tablespoon soy sauce
1 tablespoon lemon juice
1 tablespoon sweet chilli sauce (no seed variety)
1 clove garlic, crushed
1 teaspoon palm sugar

1. Trim fat from steak and cut into 2 cm cubes. Combine steak with soy, sesame oil, garlic and ginger in a large bowl. Refrigerate for several hours or overnight.
2. To make satay sauce, combine all ingredients in a small saucepan. Cook, over a low heat until the ingredients come together and thicken slightly.

Tip: If making sauce in advance and then reheating, you may need to add a little water to thin the mixture down.

3. Preheat BBQ Grill on SuperSear for 10 minutes. Thread meat onto skewers.
4. Cook skewers on grill plate until browned all over and just cooked through. Brush with a small amount of the peanut sauce before serving if desired or leave plain and serve sauce as a dipping sauce.

Makes approx
24 skewers

Recipes continued

Souvlaki Lamb Skewers

**Makes approx
22 skewers**

- 1 kg diced lamb, 2 cm pieces
 - 2 cloves garlic, crushed
 - 1 tablespoon chopped fresh oregano
 - 2 tablespoons lemon juice
 - ¼ cup olive oil
 - 1 yellow capsicum
 - 1 red capsicum
 - 1 large red onion
 - 22-24 small bamboo skewers
1. Combine lamb, garlic, oregano, lemon juice and olive oil, mix until combined.
 2. Place lamb in marinade and allow marinating for a minimum one hour or overnight.
 3. Cut capsicum and onions into pieces slightly smaller than the lamb. Skewer about 3 pieces each of meat and vegetables onto the bamboo skewers.
 4. Preheat BBQ Grill on SuperSear for 10 minutes.
 5. Cook skewers, turning until browned on all sides and cooked as desired.

Soya Sauce Chicken Wings

Serves 4

- 1 ½ kg chicken wings
 - ⅓ cup honey
 - ½ cup low salt soy sauce
 - 2 teaspoons Chinese cooking wine (optional)
 - 2 cloves garlic, crushed
 - 3 teaspoons grated fresh ginger
1. Cut wings at joints and discard tips.
 2. Combine remaining ingredients and chicken in a baking dish and marinate for at least 2 hours.
 3. Preheat BBQ Grill on SuperSear for 10 minutes. Remove wings from marinade; reserve liquid.
 4. Cook wings, on both sides, brushing with reserved marinade. Turn wings often. Cook for about 15 minutes or until browned and cooked through.
 5. Serve with rice.

Tip: Chinese cooking wine is available from Asian grocery stores. If you cannot find it simply replace with sherry or omit completely.

Recipes continued

Spicy Middle Eastern Chicken Skewers

Serves 4

- 750g thigh fillets
 - 1 tablespoon lemon juice
 - 1 tablespoon Moroccan seasoning spice mix
 - 1 clove garlic, crushed
 - 2 tablespoons olive oil
 - 12 small wooden skewers
1. Trim fat from thigh fillets and cut into bite size pieces.
 2. Combine remaining ingredients in a large bowl and marinate chicken for 3-4 hours in the refrigerator.
 3. Preheat BBQ Grill on SuperSear for 10 minutes.
 4. Thread chicken onto skewers. Cook skewers on grill plate, turning until chicken is browned and cooked through.

Serving suggestion: Serve chicken with a cucumber mint dipping sauce.

Grilled Chicken Breast with Salsa Verde

Serves 6

- 1-2 tablespoons olive oil
- 6 chicken breast fillets

Salsa Verde

- 1 cup flat leaf parsley
- ½ cup dill
- ½ cup mint leaves
- 2 cloves garlic
- 1 tablespoon small capers
- 1 tablespoon grated lemon rind
- Sea salt and freshly ground black pepper
- ¾ cup extra virgin olive oil

1. Preheat BBQ Grill on SuperSear for 10 minutes.
2. Rub oil onto chicken breast fillets. Cook chicken, uncovered, until browned on both sides and cooked through. Remove from heat and serve with Salsa Verde
3. To make the Salsa Verde, blend or process all ingredients until a chunky sauce texture is achieved.

Tip: Salsa Verde also goes very well with pan fried fish fillets.

Recipes continued

Grilled Fish with Garlic and Lemon

4 fillets
(800g) white fish fillets of choice
¼ cup olive oil
2 cloves garlic, crushed
¼ cup lemon juice
2 eschalots, minced
¼ cup shredded fresh basil leaves
Sea salt
Freshly ground black pepper
Salad, to serve
Lemon wedges, to serve

1. Place fish in a shallow dish. In a small bowl combine the oil, garlic, lemon juice, eschalots, basil, salt and pepper and mix well.
2. Pour marinade over fish and allow to sit at room temperature for 15 minutes or in the refrigerator for no more than 1 hour.
3. Preheat BBQ Grill on SuperSear. Cook fish for 3-5 minutes on both sides until just cooked through.

Note: Cooking time will vary depending on the thickness of each fillet.

4. Serve fish with salad and lemon wedges

Serves 4

Grilled Vegetable Salad with Haloumi

1 red capsicum
1 yellow capsicum
2 zucchini
2 baby eggplant
200g Haloumi cheese, sliced
200g baby rocket
1 red onion, sliced

Red Wine Dressing

1 tablespoon red wine vinegar
3 tablespoons extra virgin olive oil
1 teaspoon caster sugar
1 teaspoon Dijon mustard
1 teaspoon sea salt

1. Preheat BBQ Grill on SuperSear.
2. Place whole capsicums onto the hotplate and cook, turning every 5 minutes until the skin has blackened. Remove from hotplate and place into a plastic bag for 5-10 minutes. Once cool, remove skin from capsicum; discard seeds and membranes. Slice into thick slices.
3. Meanwhile slice the zucchini and eggplants into thin strips and cook on the hotplate on both sides until tender. Remove from heat and allow to cool.
4. Cook the haloumi on the hotplate for about 1 minute or until heated through.
5. Combine the dressing ingredients in a jar and shake well; pour over the grilled vegetables, baby rocket and red onion, toss to combine.
6. Divide salad onto 4 plates and top with haloumi cheese

Serves 4

Recipes continued

Beef fajitas

600g skirt steak
½ cup orange juice
½ cup pineapple juice
½ cup soy sauce
1 red capsicum, sliced
1 yellow capsicum, sliced
1 red onion, sliced
½ iceberg lettuce, shredded
1 cup grated cheese
½ cup sour cream
½ cup salsa
1 avocado, chopped
8-12 flour tortillas, warmed

1. Trim any fat from beef. Place beef in a deep dish and pour over the combined juices and soy sauce. Marinate in refrigerator for at least 2 hours.
2. Preheat BBQ Grill on SuperSear. Remove beef from marinade; reserve liquid. Cook beef for about 5 minutes each side or until cooked as desired. Remove from grill and cover with foil while the vegetables cook.
3. Place vegetables on hotplate and cook in batches for 2-3 minutes. Pour over some of the reserved liquid over the vegetables and cook for a further 1 minute. Remove from heat.
4. Slice beef across the grain into thick slices.
5. To serve fajitas, place a little of each of the beef, vegetables and remaining ingredients in the flour tortilla and roll up.

Serves 4

Grilled swordfish

4 pieces swordfish
2 cloves garlic, crushed
⅓ cup white vinegar
⅓ cup olive oil
¼ cup shredded basil leaves

Salad

250g baby rocket
100g semi dried tomatoes
150g feta cheese
100g katamata olives

1. Place swordfish in a large dish and pour over two thirds of the combined dressing ingredients. Cover and refrigerate for 1 hour.
2. Preheat BBQ Grill on SuperSear.
3. Cook swordfish for about 3 minutes each side or until cooked as desired.
4. Serve swordfish over salad and drizzle with remaining dressing.

Serves 4

Recipes continued

Steamed Salmon Parcels

Serves 4

4 x 180g Atlantic salmon fillets
1 stalk lemon grass, white only, chopped finely
4 eschalots, sliced thinly
1/3 cup coriander leaves
1 large red chilli, seeded and sliced
2 cloves garlic, crushed
2 teaspoons grated fresh ginger
1/2 cup coconut milk
Sea salt
Freshly ground black pepper
1 tablespoon peanut oil
4-6 baby bok choy, quartered
Steamed jasmine rice, to serve

1. Preheat BBQ Grill on SuperSear for 10 minutes.
2. Combine the lemon grass, eschalots, coriander, chilli, garlic, ginger, coconut milk, salt and pepper in a bowl and mix well.
3. Place each piece of salmon on four individual pieces of aluminium foil. Divide the coconut mixture evenly over the tops of the salmon. Fold each piece of foil up to make 4 sealed parcels.
4. Place parcels on BBQ Grill for about 15 minutes or until cooked as desired. Remove from heat.
5. Heat oil on flat side of BBQ Grill and quickly cook bok choy until just wilted; season with salt and pepper.
6. Serve salmon with bok choy and steamed jasmine rice.

Grilled Mushrooms Serves 6 as part of a meal

6 large flat mushrooms
1/4 cup olive oil
2 cloves garlic, chopped finely
2 tablespoons chopped fresh basil
sea salt and freshly ground pepper

1. Preheat BBQ Grill on SuperSear for 10 minutes.
2. Peel mushrooms and remove stems.
3. Cook mushrooms with the underside face down onto the grill plate for 2-3 minutes. Turn mushrooms over, sprinkle with olive oil, garlic, basil and salt and pepper.
4. Cook mushrooms, for a further 10-15 minutes or until cooked as desired.

Crunchy corn cobs in husks

Serves 6

- 6 corn cobs with husks on
125g butter, softened
2 bacon rashers, chopped finely
2 tablespoons chopped fresh basil
1. Preheat BBQ Grill on SuperSear for 10 minutes.
 2. Carefully pull back husks from corn cobs but do not remove completely; discard silks.
 3. Combine the butter, bacon and basil together. Using a knife or your fingers spread the butter mixture generously over the kernels. Pull husks back over corn.
 4. Cook corn on grill plate, turning occasionally for about 10 minutes.
 5. To serve, pull back husks and enjoy!

Recipes continued

Grilled Mango Cheeks with Sweet Lime Ricotta Cream

4 large mangos
2 tablespoons caster sugar

Ricotta Cream

300g fresh ricotta
2 tablespoons icing sugar, sifted
½ teaspoon vanilla essence
1 teaspoon grated lime zest
1 tablespoon lime juice

1. To make the ricotta cream, process the ricotta, icing sugar, vanilla, lime zest and juice in a food processor or mixer until smooth. Transfer mixture to a bowl, cover and refrigerate for 1 hour.
2. Preheat BBQ Grill on SuperSear for 10 minutes.
3. Cut 2 large cheeks (wide sides) from the mango. Cut into flesh of mango in a crisscross design, making sure that you don't cut through the skin.
4. Sprinkle the mango cheeks with the caster sugar and place on hot grill flesh side down, for about 5 minutes or until the sugar browns.
5. Remove mango cheeks from BBQ Grill. Carefully push mango from the skin side so that the flesh all separates. Serve mango cheeks topped with the lime ricotta cream. Serve immediately.

Tip: Remove flesh from remaining mango seeds. Roughly chop and freeze in ice cube trays and use in smoothies.

Serves 4-8

Caramelised bananas with Hot Chocolate Sauce and Whipped Cream

4 large bananas
¼ cup firmly packed brown sugar
1 teaspoon cinnamon
Whipped cream, to serve

Hot chocolate sauce

100g dark chocolate, chopped
30g white marshmallows, chopped
150ml thickened cream

1. Preheat BBQ Grill on SuperSear for 10 minutes.
2. Cut bananas in half lengthways, leaving the skin on. Sprinkle the combined sugar and cinnamon over the cut bananas. Press gently into the banana.
3. Place bananas, cut side down and cook for about 6 minutes or until the sugar has caramelised and the banana has softened. Serve bananas with hot chocolate sauce and whipped cream.
4. To make the hot chocolate sauce, combine all ingredients in a small saucepan and cook, stirring, over a low heat, until melted.

Serves 4

Notes

Notes

12 Month Replacement Guarantee

In the unlikely event that this appliance develops any malfunction within 12 months of purchase (3 months commercial use) due to faulty materials or manufacture, we will replace it for you free of charge.

Should you experience any difficulties with your appliance, please phone our customer service line for advice on 1300 881 861 in Australia, or 0800 786 232 in New Zealand. Alternatively, you can send a written claim to Sunbeam at the address listed below. On receipt of your claim, Sunbeam will seek to resolve your difficulties or, if the appliance is defective, advise you on how to obtain a replacement or refund.

Your Sunbeam 12 Month Replacement Guarantee naturally does not cover misuse or negligent handling and normal wear and tear.

Similarly your 12 Month Replacement Guarantee does not cover freight or any other costs incurred in making a claim. Please retain your receipt as proof of purchase.

The benefits given to you by this guarantee are in addition to your other rights and remedies under any laws which relate to the appliance.

Our goods come with guarantees that cannot be excluded under the Australian Consumer Law and under the New Zealand Consumer Guarantees Act.

In Australia you are entitled to a replacement or refund for a major failure and for compensation for any other reasonably foreseeable loss or damage. You are also entitled to have the goods repaired or replaced if the goods fail to be of acceptable quality and the failure does not amount to a major failure.

Should your appliance require repair or service after the guarantee period, contact your nearest Sunbeam service centre.

For a complete list of Sunbeam's authorised service centres visit our website or call:

Australia

www.sunbeam.com.au

1300 881 861

Units 5 & 6, 13 Lord Street
Botany NSW 2019 Australia

New Zealand

www.sunbeam.co.nz

0800 786 232

26 Vestey Drive, Mt Wellington
Auckland, New Zealand

Need help with your appliance?

Contact our customer service team or visit our website for information and tips on getting the most from your appliance.

In Australia

Visit www.sunbeam.com.au

Or call 1300 881 861

In New Zealand

Visit www.sunbeam.co.nz

Or call 0800 786 232

 is a registered trademark.

Made in China.

Due to minor changes in design or otherwise, the product may differ from the one shown in this leaflet.

© Copyright. Sunbeam Corporation Limited 2011.

ABN 45 000 006 771

Units 5 & 6, 13 Lord Street
Botany NSW 2019 Australia

Unit 3, Building D
26 Vestey Drive
Mt Wellington Auckland
New Zealand

Sunbeam Corporation is a division of GUD Holdings Ltd.