

CX2077x Product Comparison

Feature	Part Number		
	CX20773	CX20774	CX20776
USB Audio	USB 2.0 Full Speed	USB 2.0 Full Speed	USB 2.0 Full Speed
Converter/Sampling Rate	2 DAC/ 2 ADC Supporting 8, 16, 24, 32, 44.1, 48 KHz	2 DAC/ 2 ADC Supporting 8, 16, 24, 32, 44.1, 48 KHz	2 DAC/ 2 ADC Supporting 8, 16, 24, 32, 44.1, 48 KHz
Tri-color PWM LED Driver	No	Yes	Yes
Microphone In	Stereo	Stereo	Differential Stereo
Headphone	Stereo	Stereo	Stereo
Differential Line Out	No	No	Yes
Text LCD Display Controller	No	No	Yes
Keypad/Buttons	8 Keys	8 Keys	24 Keys
Four Position Toggle Switch	Yes	Yes	Yes
I ² S	Yes	Yes	Yes
SPDIF Out	Yes	Yes	Yes
DSP	Yes	Yes	Yes
Auxiliary Input	Yes	Yes	Yes
Package	48 QFN	48 QFN	64 QFN

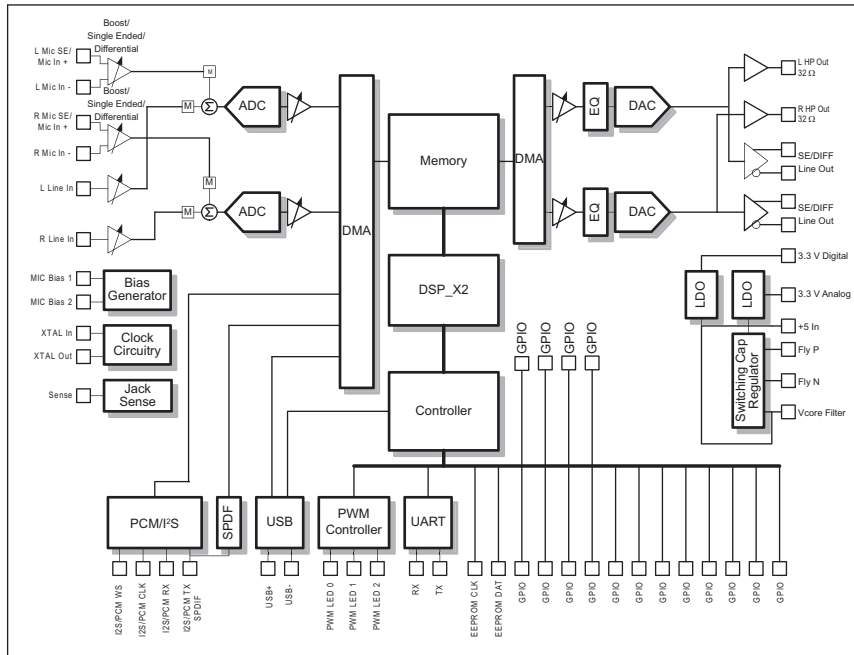

CX2077x System Block Diagram

Conexant Product Portfolio

Conexant's comprehensive product portfolio includes solutions for imaging, audio, video surveillance, and embedded modem applications.

© 2011 Conexant Systems, Inc. All Rights Reserved. Conexant and the Conexant logo are registered trademarks of Conexant Systems, Inc. All other trademarks are owned by their respective owners. Although Conexant strives for accuracy in all its publications, this material may contain errors or omissions and is subject to change without notice. **THIS MATERIAL IS PROVIDED AS IS AND WITHOUT ANY EXPRESS OR IMPLIED WARRANTIES, INCLUDING MERCHANTABILITY, FITNESS FOR A PARTICULAR PURPOSE AND NON-INFRINGEMENT.** Conexant shall not be liable for any special, indirect, incidental or consequential damages as a result of its use.

www.conexant.com
 General Information:
 U.S. and Canada: (888) 855-4562
 International: 1+ (949) 483-3000
 Headquarters
 4000 MacArthur Blvd.
 Newport Beach, CA 92660

Doc# PBR-202763

