

**Specifications - Engineering Data - Dimensions**

***HORIZONTAL  
HIGH PRESSURE  
RECEIVERS***

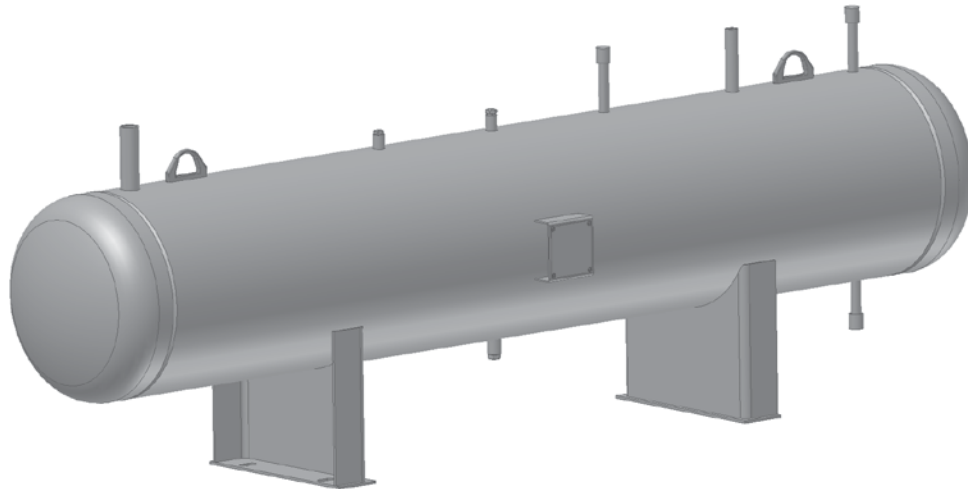

**DESCRIPTION**

Horizontal high pressure receivers provide the main source of liquid refrigerant for a refrigeration system. It also provides a place to store refrigerant as needed to minimize the effect of system transients. In some system designs the high pressure receiver is also designed to store the entire system charge. This allows the system to be pumped down for maintenance.

**FEATURES**

- Designed, fabricated, and certified to the ASME BPV Code and Manufacturer’s Data Report registered with the National Board
- 250 psi standard design pressure (300 psi on 24 inch and smaller)
- Post-weld heat treatment
- High-quality, corrosion-resistant, long-lasting epoxy paint
- Customizable nozzle orientation, distance and size, etc. via CoolWare®
- Shipped fully sealed and pressurized with a nominal nitrogen charge to maintain cleanliness and protect internal surfaces

**OPTIONS**

- Post-weld heat treatment deduct
- Higher design pressures for non-ammonia applications
- Ship-loose level column with level eyes and level probe
- Additional thermosyphon connections, drop leg, or liquid injection nozzles
- Corrosion allowance

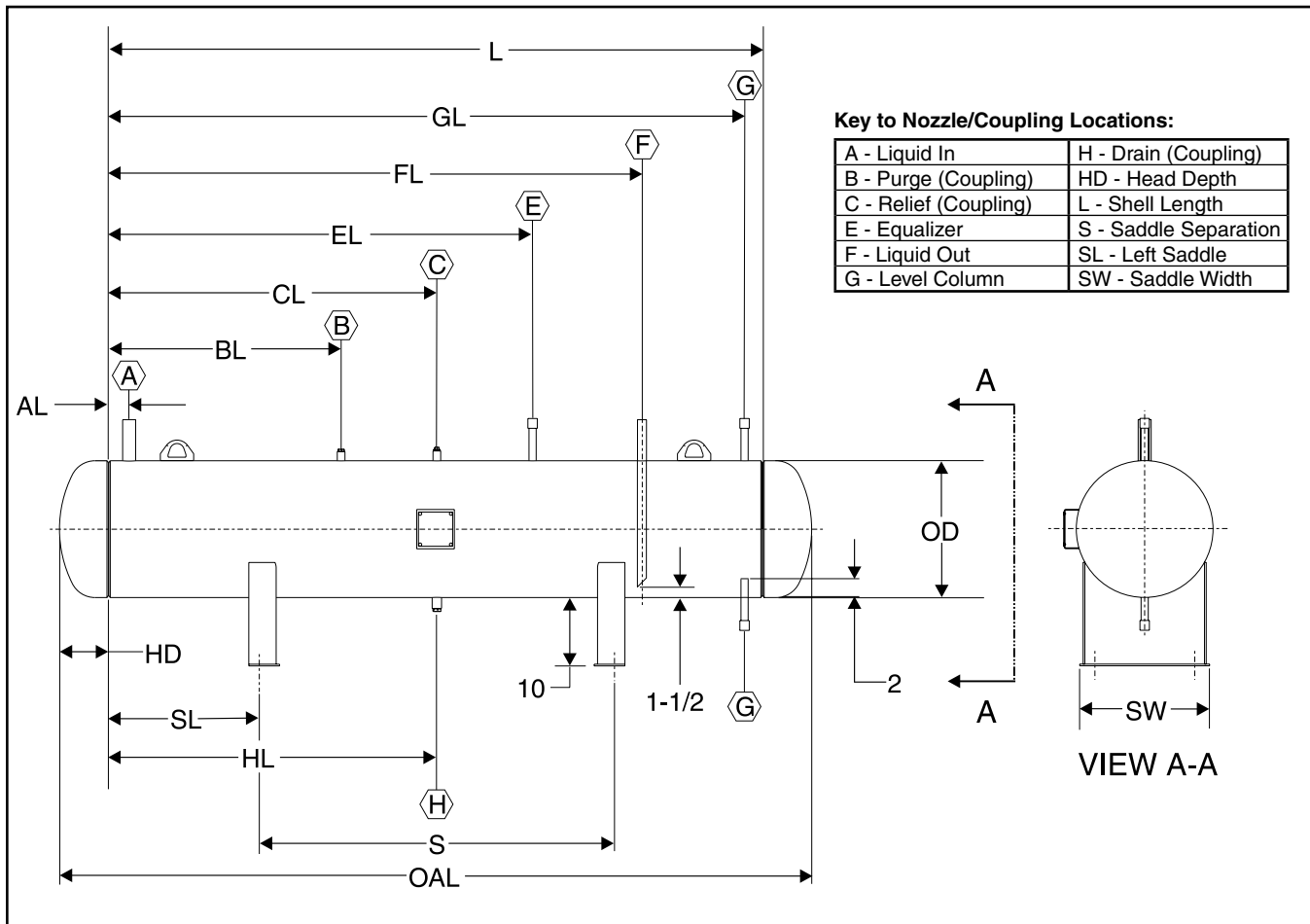
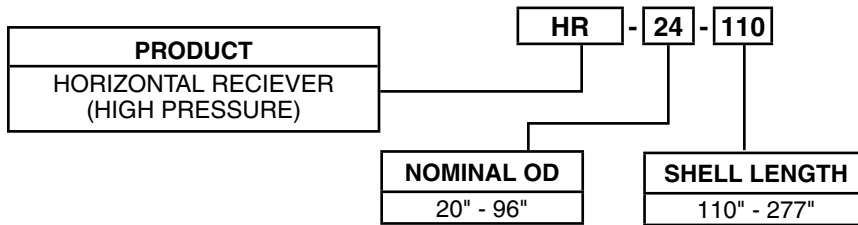

Figure 1 - Data and Dimensions

**NOMENCLATURE**



**DIMENSIONAL DATA <sup>(1)</sup>**

MODEL NUMBER	MAWP (psig)	VESSEL		Dry Weight (lb)	VOLUME <sup>(2)</sup> (ft <sup>3</sup> )	R-717 <sup>(3)</sup> (lbf)	L	HD
		OD (in.)	OAL (in.)					
HR-20-110	300	20	110 <sup>3</sup> / <sub>8</sub>	850	17.9	592	96	7 <sup>3</sup> / <sub>16</sub>
HR-20-134	300	20	134 <sup>3</sup> / <sub>8</sub>	1,030	22.0	726	120	7 <sup>3</sup> / <sub>16</sub>
HR-24-136	300	24	136 <sup>3</sup> / <sub>8</sub>	1,260	32.4	1,069	120	8 <sup>3</sup> / <sub>16</sub>
HR-24-160	300	24	160 <sup>3</sup> / <sub>8</sub>	1,480	38.3	1,264	144	8 <sup>3</sup> / <sub>16</sub>
HR-24-184	300	24	184 <sup>3</sup> / <sub>8</sub>	1,700	44.2	1,459	168	8 <sup>3</sup> / <sub>16</sub>
HR-30-163	250	30	163 <sup>3</sup> / <sub>8</sub>	1,880	61.3	2,027	144	9 <sup>1</sup> / <sub>16</sub>
HR-30-187	250	30	187 <sup>3</sup> / <sub>8</sub>	2,160	70.7	2,336	168	9 <sup>1</sup> / <sub>16</sub>
HR-30-207	250	30	207 <sup>3</sup> / <sub>8</sub>	2,390	78.5	2,593	188	9 <sup>1</sup> / <sub>16</sub>
HR-36-166	250	36	166 <sup>3</sup> / <sub>8</sub>	2,300	90.2	2,982	144	11 <sup>3</sup> / <sub>16</sub>
HR-36-190	250	36	190 <sup>3</sup> / <sub>8</sub>	2,630	103.8	3,430	168	11 <sup>3</sup> / <sub>16</sub>
HR-36-210	250	36	210 <sup>3</sup> / <sub>8</sub>	2,910	115.1	3,803	188	11 <sup>3</sup> / <sub>16</sub>
HR-42-193	250	42	193 <sup>3</sup> / <sub>8</sub>	3,120	143.7	4,748	168	12 <sup>1</sup> / <sub>16</sub>
HR-42-213	250	42	213 <sup>3</sup> / <sub>8</sub>	3,440	159.1	5,259	188	12 <sup>1</sup> / <sub>16</sub>
HR-48-196	250	48	196 <sup>1</sup> / <sub>2</sub>	4,820	188.4	6,228	168	14 <sup>1</sup> / <sub>4</sub>
HR-48-216	250	48	216 <sup>1</sup> / <sub>2</sub>	5,310	208.5	6,891	188	14 <sup>1</sup> / <sub>4</sub>
HR-54-199	250	54	199 <sup>1</sup> / <sub>2</sub>	5,500	242.2	8,004	168	15 <sup>3</sup> / <sub>4</sub>
HR-54-219	250	54	219 <sup>1</sup> / <sub>2</sub>	6,060	267.7	8,848	188	15 <sup>3</sup> / <sub>4</sub>
HR-60-202	250	60	202 <sup>1</sup> / <sub>2</sub>	6,210	303.2	10,023	168	17 <sup>1</sup> / <sub>4</sub>
HR-60-222	250	60	222 <sup>1</sup> / <sub>2</sub>	6,820	334.9	11,069	188	17 <sup>1</sup> / <sub>4</sub>
HR-60-246	250	60	246 <sup>1</sup> / <sub>2</sub>	7,560	372.9	12,324	212	17 <sup>1</sup> / <sub>4</sub>
HR-72-232	250	72	232 <sup>5</sup> / <sub>8</sub>	10,690	499.6	16,512	192	20 <sup>5</sup> / <sub>16</sub>
HR-72-256	250	72	256 <sup>5</sup> / <sub>8</sub>	11,800	554.2	18,317	216	20 <sup>5</sup> / <sub>16</sub>
HR-72-276	250	72	276 <sup>5</sup> / <sub>8</sub>	12,720	599.7	19,821	236	20 <sup>5</sup> / <sub>16</sub>
HR-84-238	250	84	238 <sup>3</sup> / <sub>4</sub>	15,340	691.4	22,853	192	23 <sup>3</sup> / <sub>8</sub>
HR-84-262	250	84	262 <sup>3</sup> / <sub>4</sub>	16,890	765.6	25,307	216	23 <sup>3</sup> / <sub>8</sub>
HR-84-282	250	84	282 <sup>3</sup> / <sub>4</sub>	18,190	827.5	27,352	236	23 <sup>3</sup> / <sub>8</sub>
HR-96-244	250	96	244 <sup>3</sup> / <sub>4</sub>	17,980	923.4	30,521	192	26 <sup>3</sup> / <sub>8</sub>
HR-96-268	250	96	268 <sup>3</sup> / <sub>4</sub>	19,750	1,020.8	33,741	216	26 <sup>3</sup> / <sub>8</sub>

**NOTES:**

1. All dimensions and nozzle nominal pipe sizes are given in inches unless noted otherwise.
2. Volume is given in total cubic feet of vessel.
3. R-717 volume estimated by using 90% total capacity filled with ammonia having a density of 36.7264 lb/cu-ft (95°F).

**NOTE: See additional data on page 4**

**DIMENSIONAL DATA <sup>(1)</sup>**

MODEL NUMBER	NOZZLE / COUPLING NPS <sup>(4)(5)(6)</sup>							NOZZLE LOCATIONS								S	SL	SW
	A	B	C	E	F	G	H	AL	BL	CL	EL	FL	GL	HL				
HR-20-110	1½	1/2	3/4	3/4	1	3/4	1	3	34	48	62	78	93	48	60	18	19	
HR-20-134	1½	1/2	3/4	3/4	1	3/4	1	3	46	60	74	102	117	60	74	23	19	
HR-24-136	2	1/2	3/4	3/4	1¼	3/4	1	3	46	60	74	102	117	60	74	23	22¾	
HR-24-160	2	1/2	3/4	3/4	1¼	3/4	1	3	58	72	86	126	141	72	89	27.5	22¾	
HR-24-184	2	1/2	3/4	3/4	1¼	3/4	1	3	70	84	98	150	165	84	103	32.5	22¾	
HR-30-163	2½	1/2	3/4	1	1¼	1	1	4	58	72	86	126	141	72	89	27.5	28	
HR-30-187	2½	1/2	3/4	1	1¼	1	1	4	70	84	98	150	165	84	103	32.5	28	
HR-30-207	2½	1/2	3/4	1	1¼	1	1	4	80	94	108	170	185	94	115	36.5	28	
HR-36-166	3	1/2	3/4	1	1½	1	1	4	58	72	86	126	141	72	89	27.5	33⅞	
HR-36-190	3	1/2	3/4	1	1½	1	1	4	70	84	98	150	165	84	103	32.5	33⅞	
HR-36-210	3	1/2	3/4	1	1½	1	1	4	80	94	108	170	185	94	115	36.5	33⅞	
HR-42-193	3	1/2	3/4	1¼	1½	1	1	4	70	84	98	150	165	84	103	32.5	38⅞	
HR-42-213	3	1/2	3/4	1¼	1½	1	1	4	80	94	108	170	185	94	115	36.5	38⅞	
HR-48-196	4	1/2	3/4	1¼	2	1	1	5	70	84	98	150	165	84	103	32.5	42¾	
HR-48-216	4	1/2	3/4	1¼	2	1	1	5	80	94	108	170	185	94	115	36.5	42¾	
HR-54-199	5	3/4	3/4	1½	2½	1	1	6	70	84	98	150	165	84	103	32.5	48	
HR-54-219	5	3/4	3/4	1½	2½	1	1	6	80	94	108	170	185	94	115	36.5	48	
HR-60-202	6	3/4	3/4	1½	3	1¼	1	8	70	84	98	150	165	84	103	32.5	53⅞	
HR-60-222	6	3/4	3/4	1½	3	1¼	1	8	80	94	108	170	185	94	115	36.5	53⅞	
HR-60-246	6	3/4	3/4	1½	3	1¼	1	8	92	106	120	194	209	106	130	41	53⅞	
HR-72-232	8	3/4	1	2	4	1¼	1	10	82	96	110	174	189	96	118	37	63½	
HR-72-256	8	3/4	1	2	4	1¼	1	10	94	108	122	198	213	108	132	42	63½	
HR-72-276	8	3/4	1	2	4	1¼	1	10	104	118	132	218	233	118	144	46	63½	
HR-84-238	10	1	1	2½	5	1¼	1	12	82	96	110	174	189	96	118	37	74	
HR-84-262	10	1	1	2½	5	1¼	1	12	94	108	122	198	213	108	132	42	74	
HR-84-282	10	1	1	2½	5	1¼	1	12	104	118	132	218	233	118	144	46	74	
HR-96-244	10	1	1	3	5	1¼	1	14	82	96	110	174	189	96	118	37	84⅞	
HR-96-268	10	1	1	3	5	1¼	1	14	94	108	122	198	213	108	132	42	84⅞	

4. Nozzle connections are supplied as pipe stubs unless otherwise specified as a coupling.
5. Couplings are ASME B16.11 Class 3000 "full" couplings.
6. Nozzles are sized for R-717 and should not be used with other refrigerants (e.g. R-507).
7. Use minimum 2 inch standoff on nameplate bracket.
8. All dimensions are subject to change; please consult factory for certified drawings.
9. Vessels are built in accordance with ASME Boiler and Pressure Vessel Code, Section VIII, Division 1.