

Contents

These pages give an overview of the contents of your owner's manual.

The first page of each section lists the topics discussed in that section.

Driver & Passenger Safety 1

The most important safety guidelines, how accessories and modifications can affect your safety, and the location of safety-related labels on your vehicle.

Instruments & Controls 9

The location, function and operation of the indicators, driver controls, and other operational components.

Before Driving.....49

The importance of wearing a seat belt, helmet and protective eyewear, how to make sure you and your Honda are ready to drive, plus load limits and guidelines on carrying cargo and towing a trailer.

Basic Operation & Driving Guidelines.....61

How to start and stop the engine, select a driving mode and gear, plus guidelines for driving on hills and other off-road situations.

Servicing Your Honda79

Why your vehicle needs regular maintenance, what you need to know before servicing your vehicle, a maintenance schedule, and instructions for specific maintenance and adjustment items.

Tips 171

How to store and transport your Honda, and how to be an environmentally responsible driver.

Contents

Taking Care of the Unexpected..... 181

What to do if you have a flat tire, your engine won't start, etc.

Technical Information 205

ID numbers, technical specifications, and other technical facts.

Consumer Information (USA & Canada only)..... 223

Information on warranties, emissions controls, how to get a service manual, and how to contact Honda.

Index..... 230

Alphabetical listing of topics in the manual.

Quick Reference

Handy facts about fuel, engine oil, tire sizes, and air pressure.

2016
Honda PIONEER SX5500M
OWNER'S MANUAL

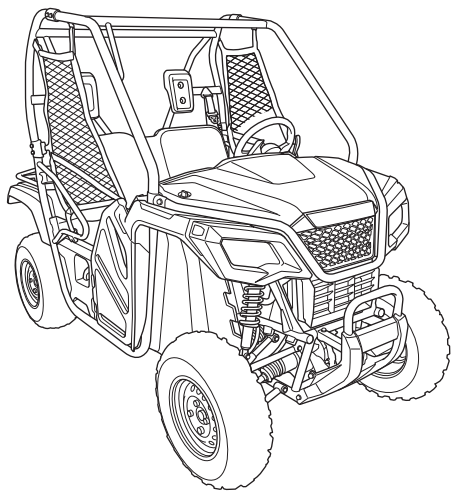

Introduction

Congratulations on choosing your Honda Pioneer. When you own a Honda, you're part of a worldwide family of satisfied customers—people who appreciate Honda's reputation for building quality into every product.

Before you begin driving your vehicle, we recommend that you read this owner's manual. It's full of facts, instructions, safety information, and helpful tips. To help you find what you are looking for, the manual contains a detailed list of contents at the beginning of each section and an alphabetical index at the back of the book.

To protect your investment, we urge you to keep your vehicle well maintained. Scheduled service is a must, of course, but it's also important to observe the break-in guidelines and perform all pre-drive and other periodic checks detailed in this manual.

As you read this manual, you will find information that is preceded by a **NOTICE** symbol. This information is intended to help you avoid damage to your Honda, other property, or the environment.

Be sure to read the Warranties Booklet (page 225) so you understand the coverages that protect your new Honda and are aware of your rights and responsibilities.

If you have any questions, or if you ever need special service or repairs, remember that your dealer knows your Honda SXS best and is dedicated to your complete satisfaction.

Introduction

Please report any change of address or ownership to your dealer so we will be able to contact you concerning important product information.

You may also want to visit our website at www.honda.com.

USA: www.powersports.honda.com.

Canada: www.honda.ca.

- The following codes in this manual indicate each country.

SXS500M

| | |
|-----------|--------------------------------|
| AC, II AC | United States of America |
| CM, II CM | Canada, Australia, New Zealand |

- The illustrations herein are based on the SXS500M AC type.
- The specifications may vary with each locale.

USA only

California Proposition 65 Warning

WARNING: This product contains or emits chemicals known to the State of California to cause cancer and birth defects or other reproductive harm.

A Few Words About Safety

Your safety, and the safety of others, is very important. And operating your Honda safely is an important responsibility.

To help you make informed decisions about safety, we have provided operating procedures and other information on labels and in this manual. This information alerts you to potential hazards that could hurt you or others.

Of course, it is not possible to warn you about all hazards associated with operating or maintaining this vehicle. You must use your own good judgment.

You will find important safety information in a variety of forms, including:

Safety Labels — on the vehicle.

Safety Messages — boxed messages preceded by a safety alert symbol  and one of three signal words: **DANGER**, **WARNING**, or **CAUTION**.

These signal words mean:

 **DANGER**

You **WILL** be **KILLED** or **SERIOUSLY HURT** if you don't follow instructions.

 **WARNING**

You **CAN** be **KILLED** or **SERIOUSLY HURT** if you don't follow instructions.

 **CAUTION**

You **CAN** be **HURT** if you don't follow instructions.

A Few Words About Safety

Safety Headings — such as “Important Safety Reminders” or “Important Safety Precautions.”

Safety Section — “Driver & Passenger Safety,” beginning on page 1.

Instructions — how to operate this vehicle correctly and safely.

In addition to the above, your owner's manual is full of information that can help you safely operate and maintain your vehicle. So please read it carefully.

Driver & Passenger Safety

This section presents some of the most important information and recommendations to help you drive your Honda safely. Please take a few moments to read these pages. This section also shows you the location of safety labels on your vehicle.

| | |
|-----------------------------------|---|
| Important Safety Information..... | 2 |
| Accessories & Modifications..... | 4 |
| Safety Labels | 6 |

Important Safety Information

There is much that you can do to protect yourself and your passenger. You'll find many helpful recommendations throughout this manual. The following are those we consider to be most important.

Follow Age and Size Recommendations

The driver should be at least 16 years old and tall enough to wear the seat belt properly and reach all the controls. A passenger should also be tall enough for the seat belt to fit properly and brace themselves, if needed, placing both feet firmly on the floor. Never allow anyone to ride in the middle of the bench seat. There is no seat belt to restrain them.

Always Wear a Seat Belt

Wearing a seat belt and positioning it properly is your best protection against injury in a crash or rollover.

Protect Your Head and Eyes

We recommend that occupants always wear a helmet with a chin strap, impact resistant goggles or eyeglasses, and clothing appropriate to the driving situation.

Keep Doors and Side Nets Closed

Making sure the doors are closed and the side nets are secure to help keep the driver and passenger arms and legs inside the occupant protective structure (OPS) should the vehicle tip or turn over.

Important Safety Information

Never Carry a Passenger in the Cargo Area

Your vehicle was designed to carry a driver and one passenger. Never carry additional passengers on the cargo area, as they could be thrown against or out of the vehicle and be seriously hurt or killed.

Obey Loading Limits & Guidelines

Do not carry more than 450 lb (203 kg) on the cargo carrier, and make sure all cargo is properly loaded, and as far forward, centered, and as low as possible. Secure items to prevent shifting.

Keep Your Vehicle in Safe Condition

It's important to keep your vehicle properly maintained and in safe operating condition. Having a breakdown can be difficult, especially if you are stranded far from your base. To help avoid problems, inspect your Honda before each use and perform all recommended maintenance.

Don't Drink and Drive

Alcohol and driving don't mix. Even one drink can affect your judgment and your ability to respond to changing conditions. Drugs can also impair your abilities. So don't drive if you are under the influence of alcohol or drugs.

Stay Off Public Roads

Your vehicle has been designed for use on private property and designated off-highway areas. It does not have turn signals or many other items required for use on either paved or unpaved public roads.

Accessories & Modifications

Modifying your vehicle or using non-Honda accessories can make it unsafe. Before you consider making any modifications or adding an accessory, be sure to read the following information.

Accessories

We strongly recommend that you use only Honda Genuine or Signature Accessories that have been specifically designed or approved and tested for your vehicle. Because Honda cannot test all other accessories, you must be personally responsible for the proper selection, installation, and use of non-Honda accessories.

You should also be aware that accessories add weight, reducing the amount of cargo you can carry, and can raise the vehicle's center of gravity, increasing the risk of a rollover.

Check with your dealer for assistance, and always follow these guidelines:

- Make sure the accessory does not obscure any lights, reduce ground clearance, limit suspension travel or steering travel, or interfere with operating any controls.
- Do not add any electrical equipment that will exceed the vehicle's electrical system capacity (page 211). A blown fuse can cause a loss of lights or engine power (page 195).

WARNING

Improper accessories or modifications can cause a crash in which you can be seriously hurt or killed.

Follow all instructions in this owner's manual regarding accessories and modifications.

Accessories & Modifications

Modifications

We strongly advise you not to remove any original equipment or modify your Honda in any way that would change its design or operation. Such changes could seriously impair your vehicle's handling, stability, and braking and make it unsafe to drive.

We also advise you not to make any modifications or remove any equipment (such as the spark arrester, muffler, or emissions control system components) that would make your vehicle illegal in your area.

Safety Labels

Your Honda comes with several labels that contain important information.

You, and anyone else who operates or rides in the vehicle, should read and understand this information before driving.

The labels should be considered permanent parts of the vehicle. If a label comes off or becomes hard to read, contact your Honda dealer for a replacement.

- ▶ Indicates something apparent.
-▶ Indicates something concealed.



radiator cap danger

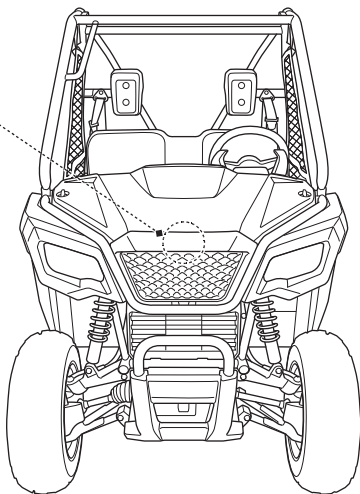

Safety Labels



general warning

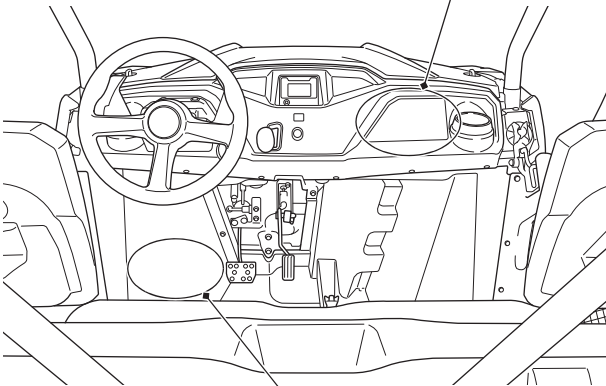

Shift and Drive select Information

- To prevent drivetrain damage, bring the unit to a complete stop before operating the reverse lever and drive mode select lever. (2WD-4WD)
- After using the 2WD/4WD select lever, the mode may not mechanically engage until forward motion begins.

shift & drive select

Safety Labels

ROPS Information

Honda of South Carolina Manufacturing, Inc.
1111 Honda Way
Timmonsville, SC

Model: SXS500M Pioneer
Test GVWR: **1,889 lbs (857 kg)**
ROPS meets requirements of OSHA Part 1928.53

OSHA

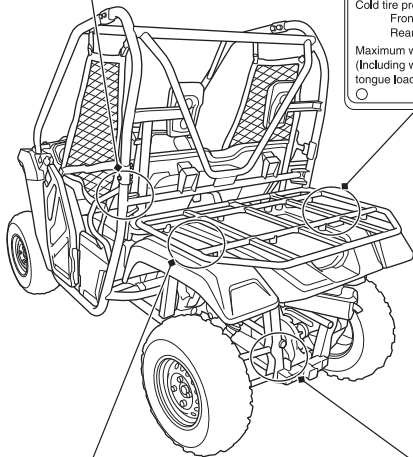

⚠ WARNING

Driving with improper tire pressure or overly worn or damaged tires can cause loss of control and result in serious injury or death.

Cold tire pressure:

Front : **10psi (70kPa)**

Rear : **10psi (70kPa)**

Maximum weight capacity : **880 lbs (399 kg)**

(Including weight of cargo, occupants, accessories, and trailer tongue load)

tire & overload warning

⚠ WARNING

SERIOUS INJURY or DEATH can result if you ignore the following.

- Individuals should not ride on cargo carrier.
- Maximum load (**450 lbs/203 kg**). Overloading can cause loss of control.
- Keep **all** cargo on the carrier rack, and as far forward, centered, and as low as possible. Secure items to prevent shifting.
- When carrying cargo, reduce speed and **allow** more room to turn and stop.
- Read the loading section in the owner's manual.

loading warning

⚠ WARNING

Improper towing can result in serious injury or death.

- Don't exceed the towing capacity.
- When towing, reduce speed, allow more room to turn and stop.
- Read the towing section in the owner's manual.

Towing Capacity

- Towing weight limit **1000 lbs. (454 kg)**
- Tongue weight limit **100 lbs. (45 kg)**

trailer hitch

Instruments & Controls

The items listed below are described in this section.

| | |
|---|----|
| Operation Component Locations | 11 |
| Indicators & Displays..... | 14 |
| Neutral Indicator | 15 |
| Reverse Indicator | 15 |
| Parking Brake Indicator | 15 |
| High Coolant Temperature Indicator | 15 |
| PGM-FI Malfunction Indicator Lamp (MIL) | 15 |
| Seat Belt Indicator..... | 15 |
| Multi-function Display..... | 18 |
| Speedometer Display | 19 |
| Odometer Display | 20 |
| Gear Position Display | 29 |
| Driver Controls | 30 |
| Ignition Switch..... | 30 |
| Headlight Switch | 31 |
| Shift Paddles..... | 32 |
| Drive Mode Select Lever..... | 33 |
| Reverse Lever | 35 |
| Parking Brake Lever | 36 |
| Doors | 37 |
| Side Nets | 38 |
| Seat..... | 40 |
| Seat..... | 40 |

(cont'd)

Instruments & Controls

| | |
|------------------------------|----|
| Seat Belts | 41 |
| Passenger Handhold | 45 |
| Storage Compartments | 46 |
| Accessory Power Socket | 47 |
| Trailer Hitch | 48 |

Operation Component Locations

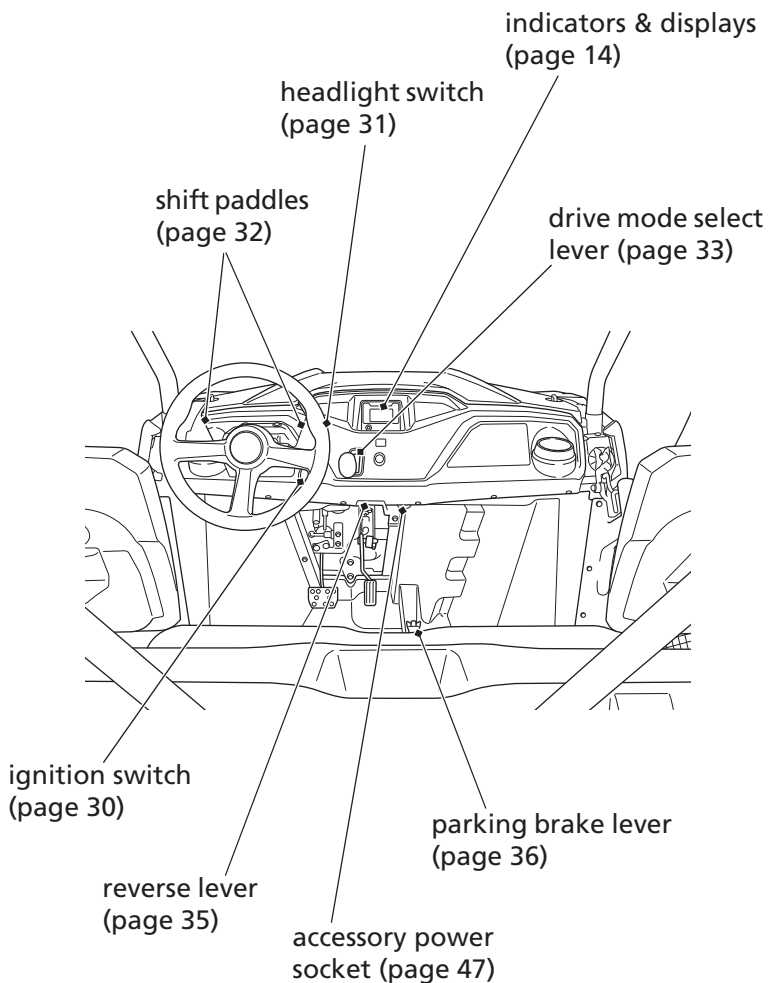

Operation Component Locations

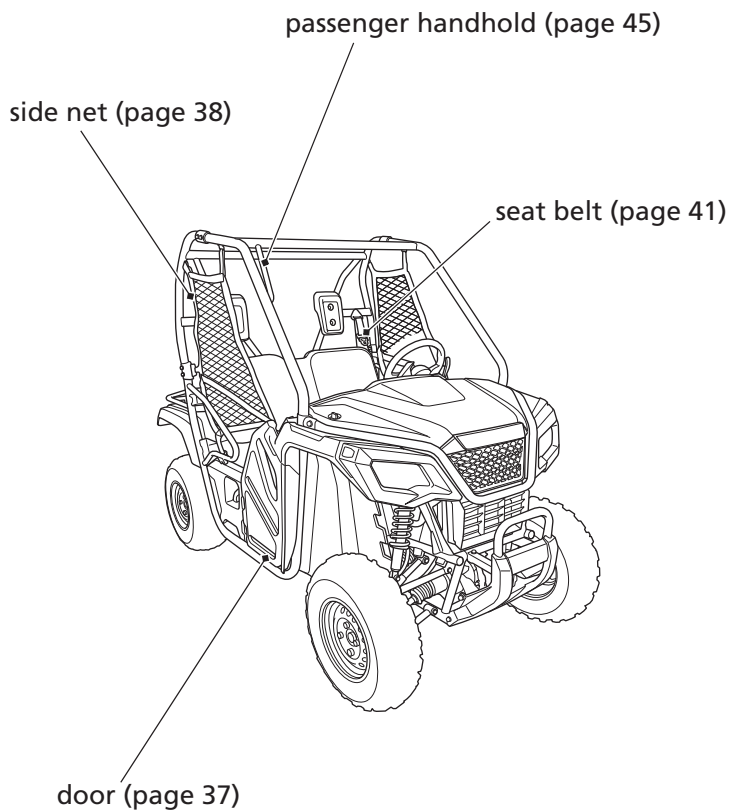

Operation Component Locations

side net (page 38)

seat belt
(page 41)

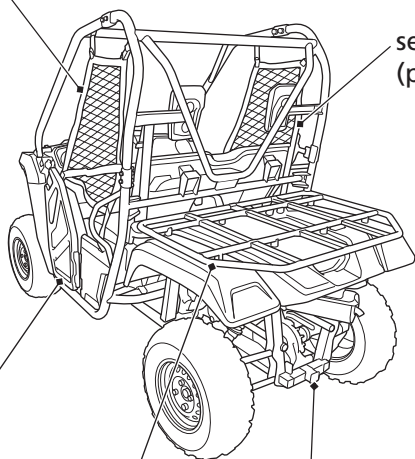

door (page 37)

cargo carrier (page 57)

trailer hitch receiver (page 48)

Indicators & Displays

The indicators and displays on your Honda SXS keep you informed, alert you to possible problems, and make your driving safer and more enjoyable. Refer to the indicators frequently. Their functions are described on the following pages.

Lamp Check

The indicators come on and go off sequentially when you turn the ignition switch to the ON (I) position.

If one of these indicators does not come on key ON check, have your dealer check for problems.

parking brake indicator

seat belt indicator

multi-function display

reverse indicator

neutral indicator

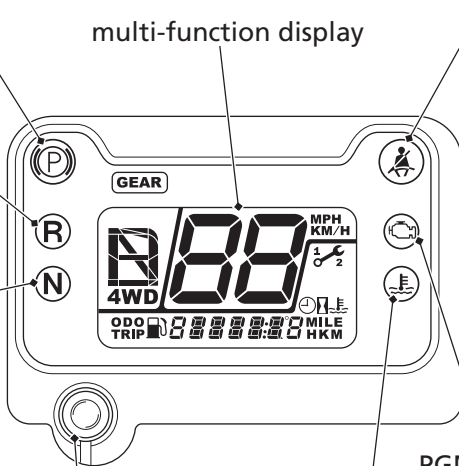

mode switch

high coolant temperature indicator

PGM-FI malfunction indicator lamp (MIL)

Indicators & Displays

N

Neutral Indicator

This indicator comes on and stays on when the transmission is in neutral.

R

Reverse Indicator

This indicator comes on and stays on when the transmission is in reverse.



Parking Brake Indicator

This indicator comes on and stays on when the parking brake is on.



High Coolant Temperature Indicator

This indicator comes on and stays on when the coolant temperature is high enough to adversely affect the service life of the engine. If this indicator comes on while you are driving, stop as soon as possible, turn the engine off, and let it cool.



PGM-FI Malfunction Indicator Lamp (MIL)

This indicator comes on and stays on when there is a problem with your vehicle's engine system. If this happens, reduce speed and take your vehicle to a dealer as soon as possible.



Seat Belt Indicator

This indicator starts flashing for few seconds, after initial display indication, when you turn the ignition switch to the ON (I) position to remind occupants to fasten their seat belts.

Indicators & Displays

| | |
|------------------------|---|
| Multi-function display | This display includes the following functions. |
| Speedometer display | Shows riding speed in miles or kilometers per hour (page 19). |
| Odometer display | Shows fuel gauge, clock, odometer, tripmeter, water temperature gauge, hour meter, maintenance trip meter and maintenance hour meter (page 20). |
| Gear position display | Shows gear position (page 29). |
| Mode switch | This button is used to select the mode, to change the mileage unit and adjust/reset the clock, tripmeter and hour meter (page 18). |

Indicators & Displays

Display Check

When the ignition switch is turned ON (I), the multi-function display will temporarily show all the modes and digital segments and initial message. So you can make sure the liquid crystal display is functioning properly.

If any part of this display does not come on during the key ON check, have your dealer check for problems.

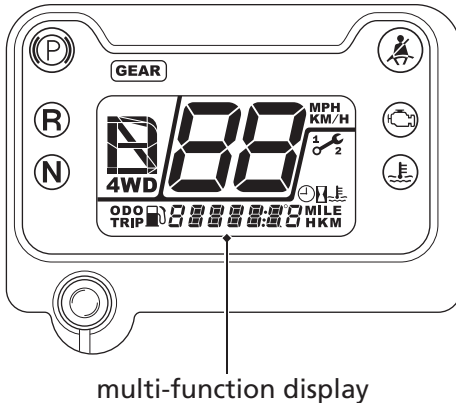

Indicators & Displays

Multi-function Display

The multi-function display consists of the following function displays:

- Speedometer display
- Odometer display
- Gear position display

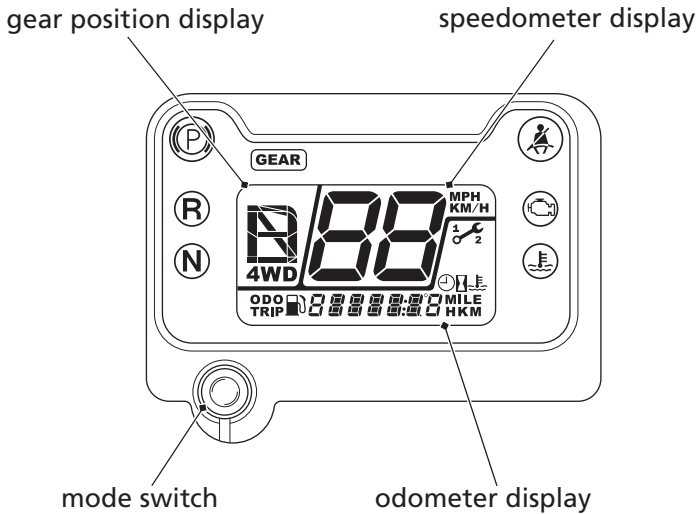

Indicators & Displays

Speedometer Display

This display shows speed in miles or kilometers per hour.

Mileage Unit Change

The speedometer, odometer, tripmeter and maintenance tripmeter show in either "MPH" and "MILE" or "KM/H" and "KM".

To change the mileage unit, press and hold the mode switch for more than 5 seconds in odometer mode (page 20) with the vehicle stopped.

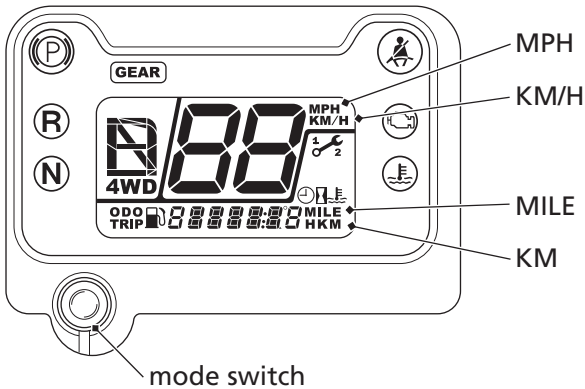

Indicators & Displays

Odometer Display

This display includes fuel gauge, digital clock, odometer, tripmeter, coolant temperature gauge, hourmeter, maintenance tripmeter, and maintenance hourmeter.

Each time you press the mode switch, mode will change as shown in the illustration.

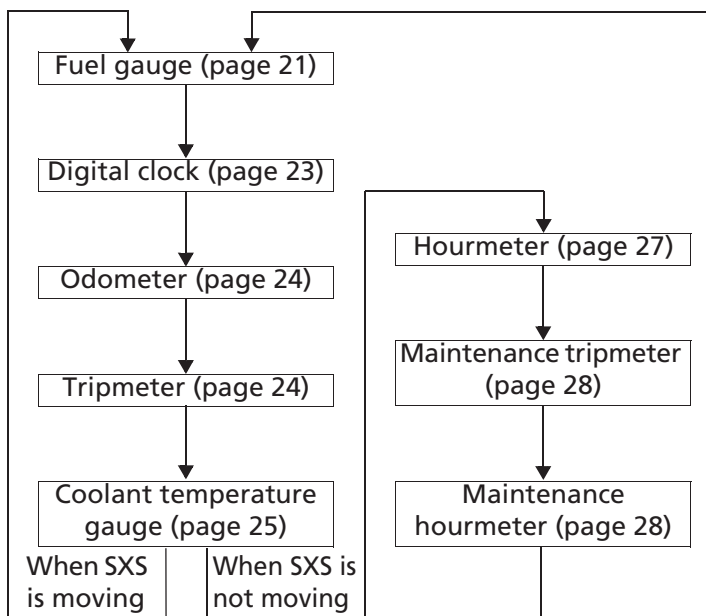

If there are unusual indications with your SXS, and mode switch is not pressed for 10 seconds, a message will automatically appear in the display.

Indicators & Displays

Fuel gauge

The fuel gauge shows the approximate fuel supply available in a graduated display with the fuel symbol. When the segment F goes on, the fuel tank capacity is:

3.96 US gal (15.0 l)

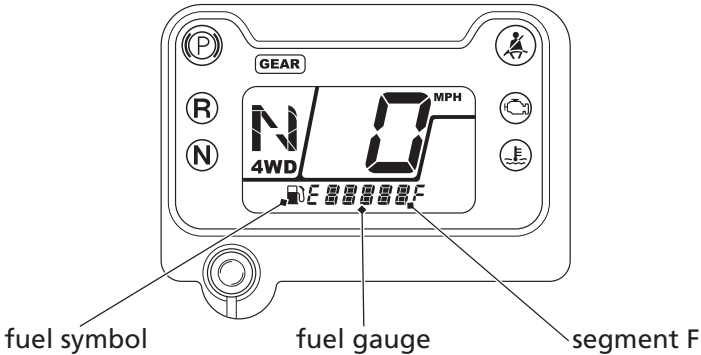

Regardless of what mode the display is in, when the fuel level reaches only one segment remaining, the display will automatically switch to the fuel gauge display. You should refuel as soon as possible.

The amount of fuel left in the tank with the vehicle on a firm, level surface is approximately:

1.11 US gal (4.2 l)

The fuel gauge and LO FUEL message will begin to flash alternately when the fuel level decreases further.

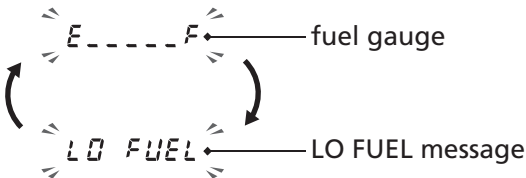

Indicators & Displays

Fuel gauge failure:

If the fuel system has an error, the fuel gauge will flash.

If this occurs, see your dealer as soon as possible.

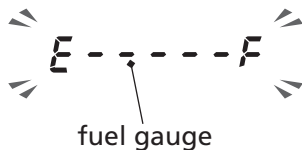

Indicators & Displays

Digital clock

The digital clock shows the hour and minutes with the 12-hour clock display.

To set the time:

1. Turn the ignition switch to ON (I).
2. Press and hold the mode switch in the clock mode. The clock will start blinking.
3. Press and hold the mode switch until the desired time appears.
4. To complete setting the clock, press the mode switch, or turn the ignition switch OFF.

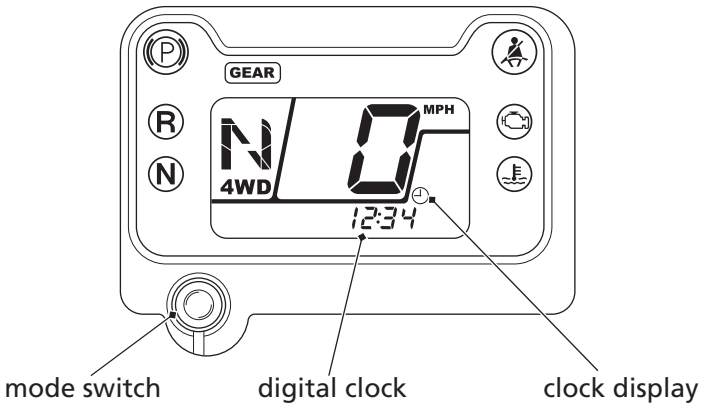

Indicators & Displays

Odometer

The odometer shows the total miles or kilometers ridden with the ODO display. The odometer locks at 999,999 when the readout exceeds 999,999.

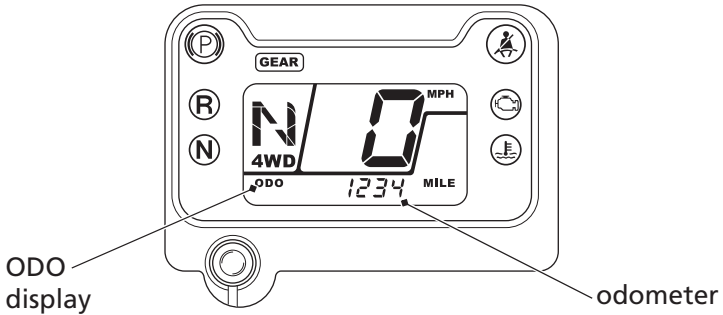

Tripmeter

The tripmeter shows the number of miles or kilometers ridden with the TRIP display, since you last reset the tripmeter. The tripmeter returns to 0 when the read-out exceeds 999.9.

To reset the tripmeter, press and hold the mode switch with the display in the tripmeter mode.

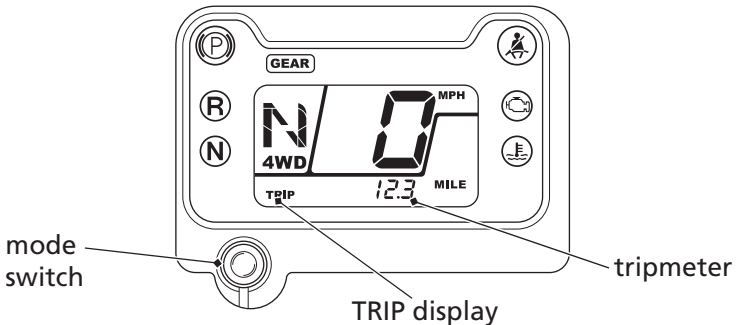

Indicators & Displays

Coolant temperature gauge

The coolant temperature gauge shows engine coolant temperature with the coolant temperature display. When the segment begins to move above the C (Cold) display, the engine is warm enough for the SXS to be ridden. When the coolant temperature is low, the coolant temperature gauge will display “Lo”. The normal operating temperature range is within the section between the H and C displays.

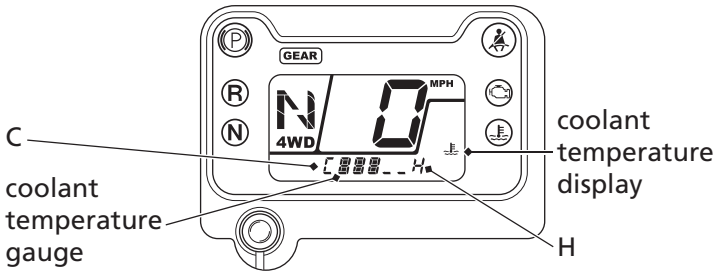

If all sections of the coolant temperature gauge, including segment H and high coolant temperature indicator are on (automatically appears in the display), stop the engine and check the reserve tank coolant level. Read page 193 and do not drive the SXS until the problem has been corrected.

NOTICE

Continuing to ride with an overheated engine can cause serious engine damage.

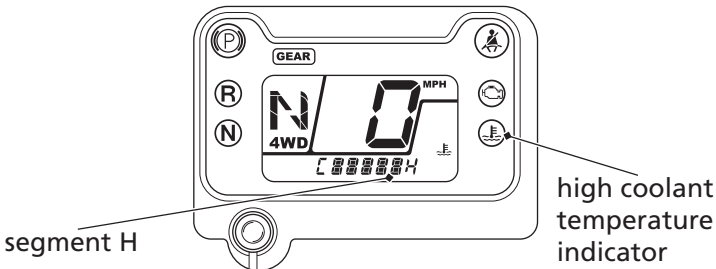

Indicators & Displays

Coolant temperature gauge failure:

If the coolant temperature system has an error, the coolant temperature gauge will flash and appear in the display, and/or the high coolant temperature indicator will turn on.

If this occurs, see your dealer as soon as possible.

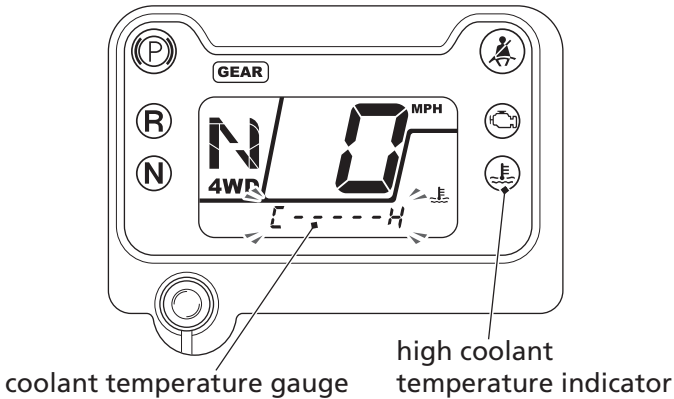

Indicators & Displays

Hourmeter

The hourmeter display shows accumulated hours while the ignition is ON (I). The hourmeter locks at 99,999.9 when the readout exceeds 99,999.9.

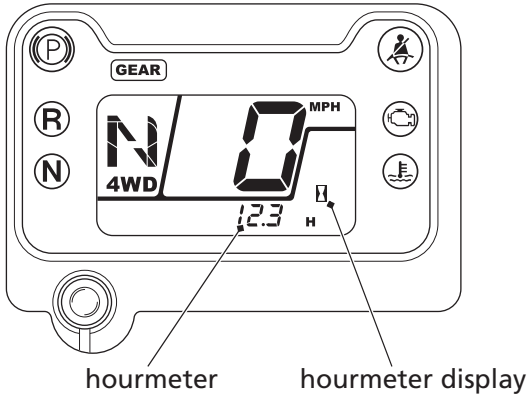

Indicators & Displays

Maintenance minder indicator

The maintenance minder indicator appears in the display when the mileage or operating hours on your Honda SXS reaches the maintenance interval specified on the maintenance schedule (page 87).

Reset the indicator after each scheduled maintenance is performed. If the scheduled maintenance is performed before the maintenance minder indicator appears, be sure to reset the maintenance minder after performing the scheduled maintenance.

Resetting the indicator:

To reset the indicator, press and continue to hold the mode switch and turn the ignition switch to ON (I). The indicator message will light up, and after 2 seconds will flash twice, the maintenance minder indicator is reset.

Also the maintenance tripmeter and maintenance hourmeter will reset.

See more details about maintenance minder indicator on page 85.

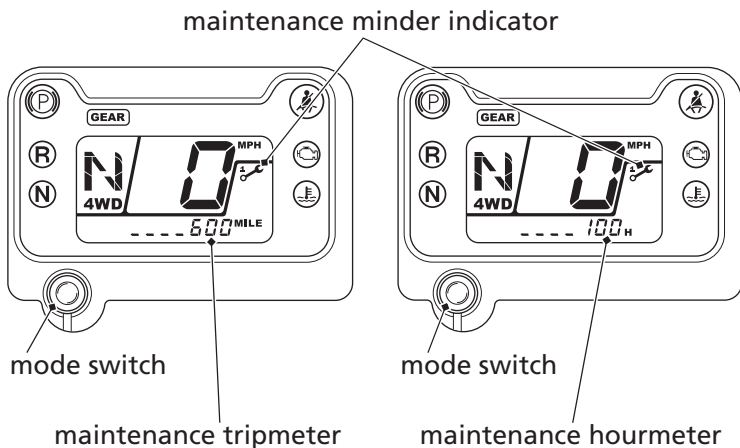

Indicators & Displays

Gear Position Display

Gear position indicator

The gear position indicator shows the gear position when the ignition switch is in the ON (I) position.

The indicator displays: N for neutral, R for reverse, and L, 2, 3, 4, 5 for the five forward gears.

“–” will be displayed on the gear position indicator when the transmission is not shifted into gear properly. Before driving, check that the gear position is properly displayed on the gear position indicator.

If the gear position indicator shows “–” and blinks, turn the ignition switch to the OFF (O) position, and then turn it back to the ON (I) position again. If the gear position indicator still shows “–” and blinks, see your dealer.

4WD indicator

This indicator will be on when the 4WD mode engages (page 33).

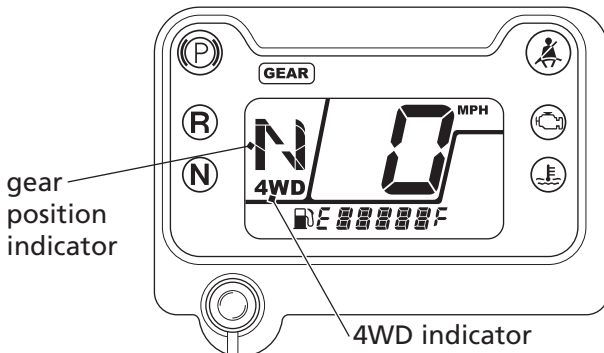

Driver Controls

Ignition Switch

The ignition switch is a three-position, key-operated switch used to start and stop the engine.

OFF (O) — The engine and all electrical circuits are off. The key can be inserted and removed only when it is in this position.

ON (I) — The electrical circuits are on. You can use the accessory power socket in this position.

START (II) — This position is used only to start the engine. The key will automatically return to the ON (I) position when you let go of it.

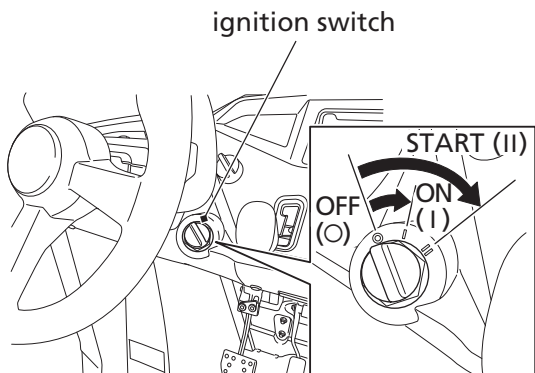

Driver Controls

Headlight Switch

The headlight switch is located on the front console, to the right side of the steering wheel. This switch turns the headlights and taillight on and off.

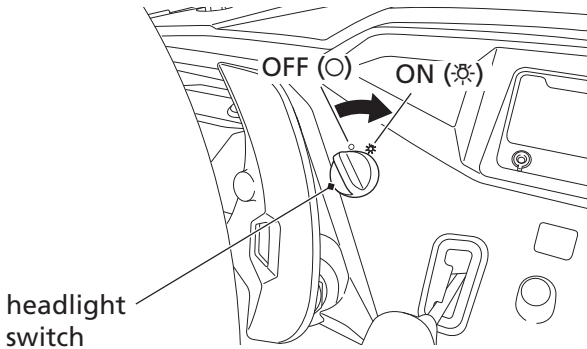

Driver Controls

Shift Paddles

Your Honda SXS is equipped with a pair of shift paddles that are located behind the steering wheel and are used to shift between R (reverse)-N (neutral)-L (low)-2-3-4-5.

downshift paddle(-)

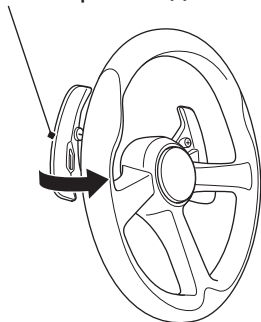

upshift paddle(+)

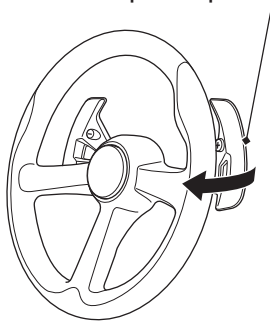

Pull the upshift paddle (+) to shift to a higher gear position and the downshift paddle (-) to shift to a lower gear position and R (reverse). See *Shifting Gears*, page 64.

Driver Controls

Drive Mode Select Lever

The drive mode select lever, located to the right of the ignition switch, has two drive mode positions: 2WD and 4WD.

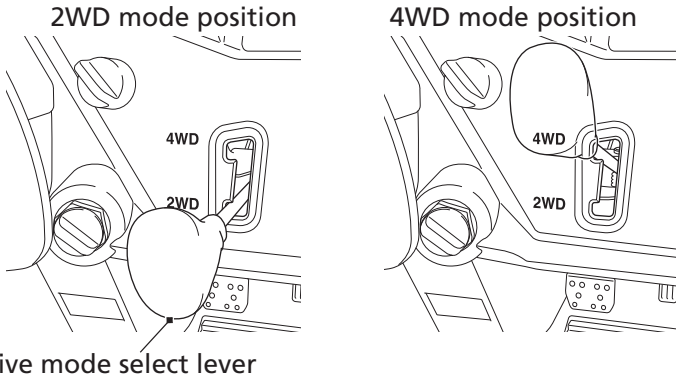

To check your present drive mode, look at the 4WD indicator.

2WD mode:

The 4WD indicator will be off when the 2WD mode is engaged.

4WD mode:

The 4WD indicator will be on when the 4WD mode is engaged.

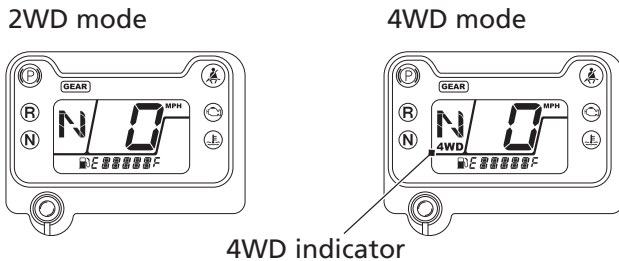

Driver Controls

You should change drive modes only when the vehicle is stopped and the engine is idling.

NOTICE

Changing drive modes while the vehicle is moving could damage the drivetrain.

After changing the drive mode, drive several yards, making right and left turns, and make sure that indicators work properly. If the indicators do not go out or come on according to the drive mode position, see your dealer.

Driver Controls

Reverse Lever

The reverse lever is located in the center of the lower dash. To operate, bring the SXS to a complete stop (the transmission cannot be shifted into reverse if the SXS is moving). Make sure the transmission is in neutral. While pulling the reverse lever and depressing the brake pedal, pull the downshift paddle (left handle shift paddle) once to shift into "R" (reverse) gear. See *Riding in Reverse*, page 67.

downshift paddle

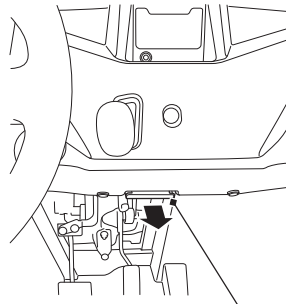
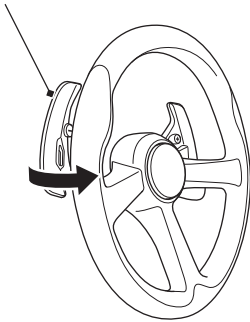

reverse lever

Driver Controls

Parking Brake Lever

The parking brake lever is located just in front of the bench seat between the driver's and passenger's seating positions. To apply the brake, pull the lever up fully. To release it, pull up slightly, push the button at the end of the lever, then lower it.

Before driving, check that the parking brake indicator is off.

**TO APPLY
THE PARKING BRAKE**

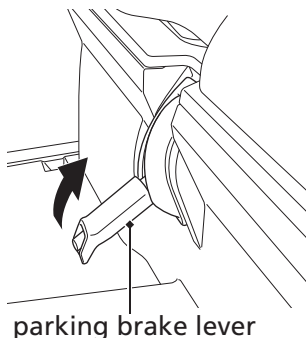

**TO RELEASE
THE PARKING BRAKE**

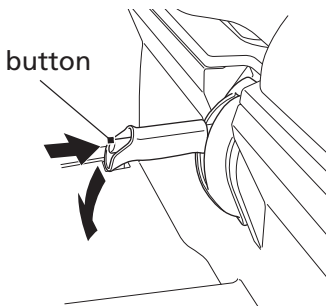

NOTICE

Driving with the parking brake on can damage the rear brake and drivetrain.

Doors

Your Honda SXS is equipped with doors to prevent branches, gravel, or other debris from getting inside the driver's compartment, and to keep the driver's and passenger's legs and feet inside the vehicle if your vehicle ever tips or overturns. Be sure all doors are securely closed before driving your Honda SXS, and never remove a door.

If a door is damaged or does not close securely, see your dealer for repair or replacement.

Do not drive the Honda SXS with the doors open or removed.

The left and right doors can be opened in the same manner.

Open

1. Turn the knob inward.
2. Open the door.

Close

1. Close the door securely until the second latch click is heard.
2. Make sure the door is closed securely.

LEFT SIDE

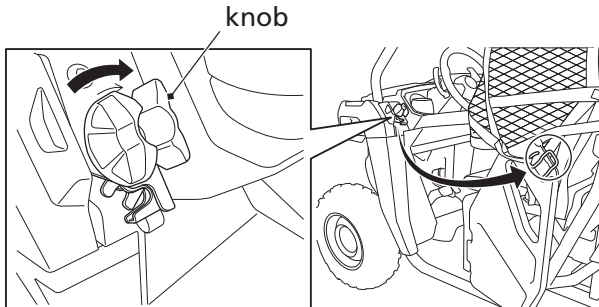

Side Nets

Your Honda SXS is equipped with side nets to prevent branches, or other debris from getting inside the driver's compartment, and to keep the driver's and passenger's hands and arms inside the occupant protective structure (OPS) if the vehicle ever tips or overturns.

The side nets are secured to the OPS with side net D-rings and side net snap hooks. To function properly, the side nets should be tight. If a side net is loose, tighten the belts on the side net D-rings.

Be sure the side nets are properly adjusted and secure to assure proper function before driving your Honda SXS, and never remove side nets from the vehicle. Inspect the condition of the side net and its mounting hardware. If there is wear, deterioration, damage, or they do not latch and tighten securely, see your dealer for repair or replacement.

Side Nets

Side Nets Set Up

The left and right side nets can be set up in the same manner.

Inspect the side nets and their mounting hardware for damage as specified in the maintenance schedule on page 87.

1. Hook the side net snap hooks.
2. Tighten the belt on the lower side net D-ring and door side net D-ring.

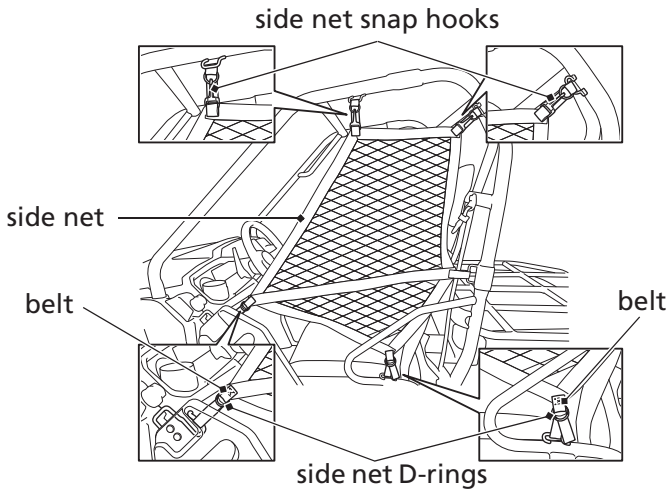

Side net snap hooks wear limit

Inspect the side net snap hooks for wear. If the side net snap hook become less than 0.24 in (6 mm), see your SXS dealer for replacement.

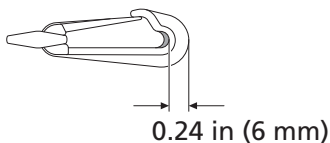

Seat

Seat

Your Honda SXS is equipped with a bench seat that has two seating positions and is designed to carry one driver and one passenger only.

The center of the bench seat is not intended as a seating position and is, therefore, not equipped with a seat belt. Do not allow someone to ride there.

WARNING

Do not sit on the center of the bench seat.

The center is not equipped with a seat belt.

Not wearing a seat belt can result in serious injury or death.

Do not drive with any cargo on the center of the seat. Cargo on the center of the bench seat can interfere with the drivers ability to control the vehicle and can be thrown around and hurt someone during an overturn or a crash.

Seat Belts

Your Honda SXS is equipped with lap/shoulder seat belts in each seating position. A seat belt keeps you connected to the vehicle so you won't be thrown out during a crash or rollover. Together with a proper helmet, a seat belt is your best protection against serious injuries in any type of crash, so make sure all occupants always buckle up before driving.

WARNING

Not wearing a seat belt, or wearing one improperly, can result in serious injury or death in a crash or rollover.

Make sure the driver and passenger always wear their seat belts properly.

Of course, seat belts cannot completely protect you in every crash. But in most cases, seat belts can reduce your risk of serious injury.

(cont'd)

Seat Belts

How you wear a seat belt also matters. For the best protection:

1. Insert the latch plate into the buckle, then tug on the belt to make sure it is securely latched.

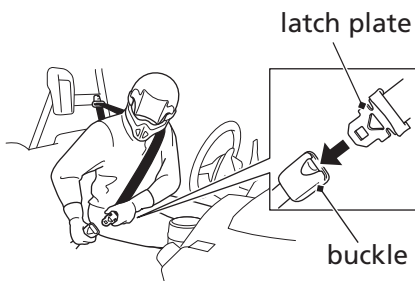

2. Check that the belt is not twisted, because a twisted belt can cause injuries.
3. Position the lap part of the belt as low as possible across your hips, then pull up on the shoulder part of the belt to make sure the lap part is snug. This keeps you connected to the vehicle and lets your strong pelvic bones take the force of a crash.
4. Make sure the shoulder part of the belt goes over your shoulder and rests against your chest.



To unlatch a seat belt, press the red PUSH button on the buckle.

Seat Belts

Seat Belt Locking Mechanism

The seat belts in your Honda SXS are equipped with a belt locking mechanism.

The belt locking mechanism is in the holder of the latch plate. When the seat belt is subjected to intense forces during a crash or rollover, part of the holder locks the belt.

LOCK POSITION

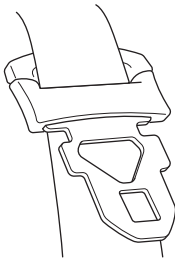

**UNLOCK POSITION
(ORDINARY USE)**

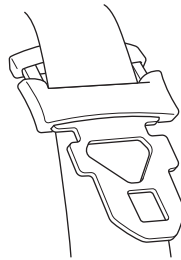

Unlock

1. To unlatch a seat belt, press the red PUSH button on the buckles.
2. Hold the latch plate and one side of the belt, and pull the other side of the belt. Doing so unlocks part of the holder.

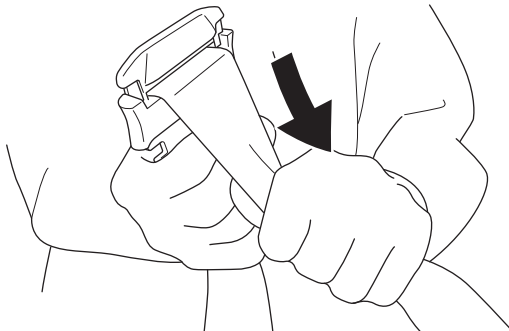

Seat Belts

If you have been driving in an extremely muddy or dusty area, be sure to inspect your belt and remove any dirt or debris before letting the belt retract into the retractor. Failure to do so could clog the retractor and make it inoperable.

Each seat belt has an emergency locking retractor. In normal driving conditions, the retractor lets you move freely in your seat while keeping some tension on the belt. During a crash or rollover, the retractor automatically locks the belt to help restrain your body.

Do not put any accessories on a seat belt, as that may reduce the effectiveness of the belt and increase the chance of injury in a crash.

If a seat belt is worn in a crash, the seat belt assembly must be replaced by your dealer. A belt that has been worn during a crash may not provide the same level of protection in a subsequent incident. The dealer should check the retractor and replace it if needed.

Passenger Handhold

Passenger Handhold

The occupant protective structure (OPS) has a handhold to give a passenger extra support when the vehicle travels over rough or bumpy terrain. Passenger can also brace their feet against the floorboard.

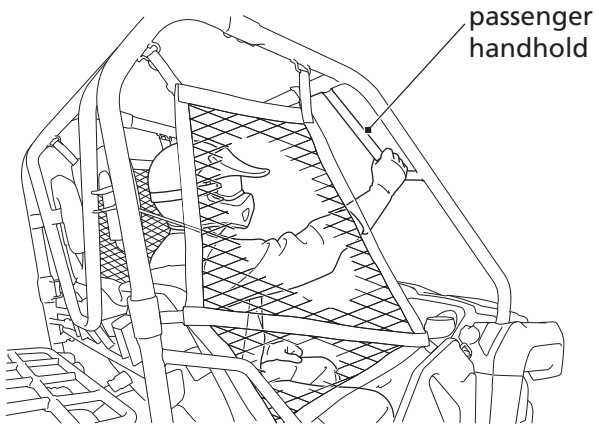

Storage Compartments

Your Honda SXS has two drink holders.

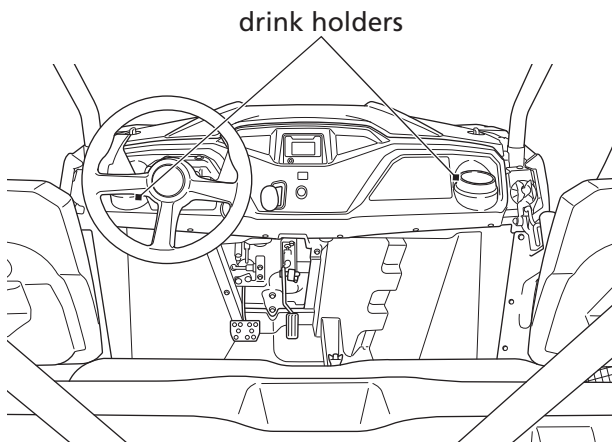

Accessory Power Socket

The accessory power socket is located in the center of the lower dash. The socket is intended for 12-volt DC accessories rated for 120 watts (10 amps) or less. Exceeding the limit can blow the accessory socket fuse (see page 195).

The socket can be used to power such items as a trouble light, spotlight, CB radio, or cell phone, but not a heat-generating accessory, such as a car cigarette lighter.

accessory power socket

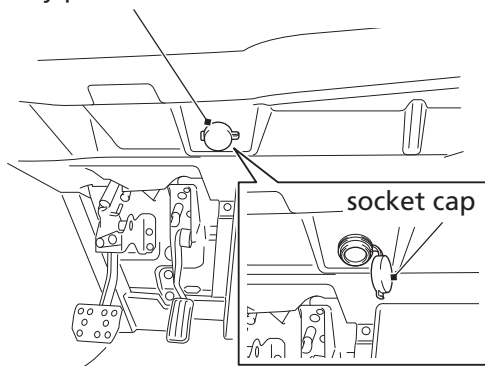

To use the accessory power socket, the engine must be on and idling.

NOTICE

Using any heat-generating accessory or improperly rated accessory can damage the socket.

Remember to close the socket cap when you are finished using an accessory, and keep water or other fluids away from the socket.

Trailer Hitch

Your Honda SXS is equipped with a trailer hitch receiver that accepts a 1 1/4 inch drawbar. You can purchase an approved drawbar from your Honda dealer.

See page 59 for page *Towing a Trailer*.

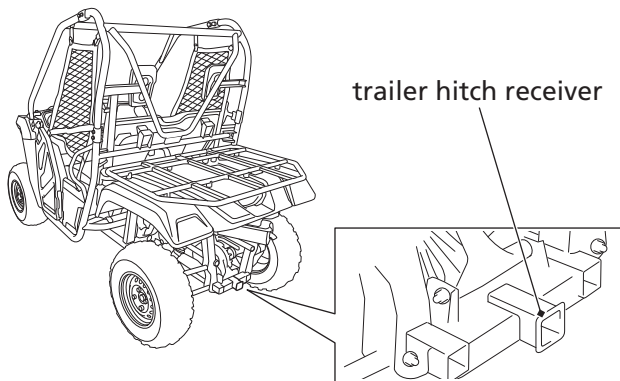

Before Driving

Before driving your SXS, you need to make sure you and your vehicle are both ready. This section discusses how to evaluate your driving readiness and what items you should check on your vehicle. It also includes important information about loading cargo.

| | |
|---------------------------------------|----|
| Are You Ready to Drive? | 50 |
| Age & Size Recommendations | 50 |
| Protective Apparel | 51 |
| Get to Know Your Vehicle | 52 |
| Don't Drink & Drive | 52 |
| Is Your Vehicle Ready to Drive? | 53 |
| Pre-drive Inspection | 54 |
| Loading Cargo | 57 |
| Load Limit..... | 57 |
| Loading Guidelines | 58 |
| Towing a Trailer..... | 59 |
| Towing Limits | 59 |
| Checking Loads | 59 |
| Loading a Trailer | 60 |

Are You Ready to Drive?

Before driving your Honda SXS for the first time, we urge you to carefully read this owner's manual and the labels on your vehicle and make sure you understand all the safety information.

Age & Size Recommendations

The driver should be at least 16 years old and tall enough to wear their seat belt properly (page 41) and operate all the controls. A passenger should also be tall enough to wear the seat belt properly and ride with both feet on the floor.

WARNING

Allowing a person who is too young or too small to drive this vehicle or ride as a passenger could result in serious injury or death in a crash.

Follow all instructions and guidelines in this owner's manual regarding the proper age and size for a driver and a passenger.

Are You Ready to Drive?

Protective Apparel

To help prevent head injury from striking an occupant protective structure (OPS) or other hard object, we recommend that occupants always wear a helmet secured with a chin strap.

To protect the eyes from brush and flying objects, we also recommend that occupants wear impact-resistant goggles or a face shield.

WARNING

Driving or riding in this vehicle without a proper helmet and eye protection can result in serious injury or death in a crash.

Always wear a helmet secured with a chin strap and eye protection when driving or riding in this vehicle.

Are You Ready to Drive?

Get to Know Your Vehicle

Because all vehicles have unique characteristics, it's important to learn how this one operates and handles. We recommend that you take time to practice using the different controls, and get accustomed to how the vehicle accelerates, brakes, and turns in different driving modes, on different surfaces, and on different terrain conditions.

Don't Drink & Drive

It's well known that alcohol and drugs can seriously affect a person's judgment, perception, and ability to safely operate any vehicle. We therefore strongly recommend that you do not drive, or let anyone else drive or ride in this vehicle, while under the influence of alcohol or drugs.

WARNING

Operating this vehicle under the influence of alcohol or drugs can result in a crash in which you or others can be seriously injured or killed.

Never drive this vehicle while under the influence of alcohol or drugs.

Is Your Vehicle Ready to Drive?

Before driving your Honda SXS, it's important to inspect the vehicle and correct any problem you find. A pre-drive inspection is a must, not only for safety, but because having a breakdown can be a major inconvenience.

If your vehicle has overturned or been involved in a crash, do not drive it until it has been inspected by your dealer. There may be damage or other problems you cannot see.

WARNING

Improperly maintaining this vehicle or failing to correct a problem before driving can cause a crash in which you or someone else can be seriously hurt or killed.

Always perform a pre-drive inspection and correct any problems before you operate the vehicle.

Is Your Vehicle Ready to Drive?

Pre-drive Inspection

Check the following items before driving your Honda SXS:

- Oil Level* Check the engine oil level and add oil, if needed (page 109). Also check under the vehicle for leaks.
- Coolant* Check the coolant level (page 121). If it is low, add a 50/50 mixture of silicate-free coolant and distilled water.
Check for leaks.
- Fuel Level* Check the fuel gauge (page 21) and add fuel, if needed (page 104). Make sure the fuel fill cap is secure. Also check for the smell of fuel or fumes - if you smell any fuel, turn the ignition switch to OFF (O) immediately, and see your dealer.
- Brake Fluid* Check the level (page 147). If it is near MIN, check the brake pads for wear (page 149). If the brake pads are within the specification, check for leaks in the braking system (page 146).
- Tires* Check the air pressure of all tires and inflate them to the proper pressure (page 154). Also inspect the tires for damage or excessive wear (page 156). If necessary see your dealer.
- Wheels* Make sure the wheel nuts are properly tightened and the wheels are not cracked or deformed (page 160).
- Driveshafts* Inspect the driveshafts and boots for damage, tears, or leaks and see your dealer if any are found.

Is Your Vehicle Ready to Drive?

Steering gearbox and boots Check the steering to make sure it turns smoothly in both directions. Check that there is no binding or play in the steering. Check for any tears in the boots. If any tears are found, see your dealer.

Underbody Check for and remove any debris stuck in the underbody; take extra care in your inspection if the vehicle was last driven in deep grass, brush, a wetland, or flooded area. Check for any visible dents or cracks. If any dents or cracks are found, see your dealer.

Air Cleaner Inspect the air cleaner element (page 126) to insure it is clean and evenly oiled.

Air Cleaner Housing Drain Tube Check for deposits in the drain tube. If necessary, clean the tube (page 129) and check the air cleaner housing.

Suspension Check the condition of all suspension components. Be sure to look for bends or oil leaks in the damper. Check for tears in the boots of the front arm ball joint.

Lights Make sure the headlights, taillights, and brake lights are working properly.

Controls Check that all driving controls, including the accelerator pedal, brake pedal, reverse lever, parking brake lever, drive mode select lever, and the shift paddles are operating smoothly.

Tie-rod ends The wheels need to be lifted off the ground to correctly check the tie-rod ends, so it cannot be done in the pre-drive inspection. To have the tie-rod ends properly inspected, see your dealer.

(cont'd)

Is Your Vehicle Ready to Drive?

- Cargo* Be sure items on the cargo carrier do not exceed the cargo limit and are properly secured to prevent shifting (pages 57, 58).
- Seat Belts* Make sure all seat belts are in good condition and operate properly. The seat belts must move smoothly when pulled out, and retract on their own when released. The latch plates should click securely into the buckles and release when the release buttons are pushed firmly.
- Side Nets* Make sure all side nets and their mounting hardware are in good condition and tighten securely.
- Exhaust System* Make sure no materials or debris are sticking to, or accumulating around, the exhaust system. If any such debris is found, remove it so there's no chance for it to catch on fire. Start the engine and listen for any leaks.

CAUTION

Exhaust system and catalyst operate at very high temperatures.
You can be burned if you touch the exhaust system or catalyst.
Do not touch the exhaust system or catalyst without letting the system cool down.

NOTICE

*Exhaust system and catalyst operate at very high temperatures. Accumulated debris and vegetation that contact the exhaust/catalyst can catch on fire.
Always conduct a pre-ride inspection and remove accumulated debris.*

Remember to take care of any problem you find or have your dealer correct it before you drive your Honda SXS.

Loading Cargo

Your vehicle was designed to carry cargo. However, carrying a load that is too heavy or improperly loaded can adversely affect your vehicle's handling, stability, and stopping distance and make it unsafe. Before carrying any type of cargo, be sure to read the following pages.

Load Limit

See page 74 for guidelines on driving with cargo.

Maximum weight capacity = 880 lb (399 kg)

This includes the weight of cargo, occupants, accessories, and trailer tongue load.

Maximum cargo weight = 450 lb (203 kg)

This includes all items on the cargo carrier, any accessories, and the tongue load if you are towing a trailer (see page 59).

The weight of added accessories will reduce the maximum cargo weight you can carry.

WARNING

Overloading the cargo carrier or failing to secure cargo properly can cause a crash in which you or others could be seriously hurt or killed.

Follow the cargo limits and loading guidelines in this owner's manual.

Loading Cargo

Loading Guidelines

- Make sure the tires are properly inflated (page 154).
- Cargo should only be carried in designated loading areas. Designated area would be drink holder, carrier rack, accessory underhood storage, etc.
- Place all items on the cargo carrier, and as far forward and centered as possible.
- Do not let items extend over the edges of the carrier, as they could get caught on something.
- Be aware that carrying tall, heavy items will significantly raise the vehicle's center of gravity, increasing the chance of a rollover.
- Never let a passenger ride in the rear cargo area or hang onto the side of the vehicle, even for a short distance. The person could be thrown off the vehicle or cause a crash.

WARNING

Driving with a passenger in the cargo area can result in very serious injury or death if the person is thrown against the vehicle.

A passenger should only ride in the passenger's seat and wear their seat belt properly.

Towing a Trailer

Your vehicle can pull a trailer as well as carry cargo, provided you follow the load limits and guidelines below.

Towing Limits

There are two main types of limits that apply to towing a trailer:

Maximum total trailer weight = 1,000 lb (454 kg)

This includes the weight of the trailer and everything in it or on it.

Maximum tongue load = 100 lb (45 kg)

The weight that the fully loaded trailer places on the tongue.

The tongue load also affects the total weight you can carry in the vehicle and the cargo carrier. See "Maximum weight capacity" on page 57.

Checking Loads

Total Trailer Weight

Check the weight of a fully loaded trailer or estimate the total by adding the weight of the trailer (as quoted by the trailer maker) with the weight of all items placed in or on the trailer.

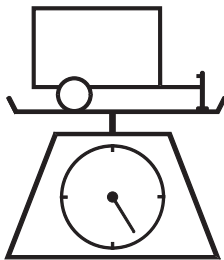

Towing a Trailer

To achieve a proper tongue load, start by placing 60 percent of the load toward the front of the trailer and 40 percent toward the rear, then readjust the load as needed.

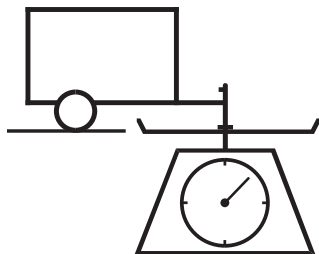

Loading a Trailer

- Always use a proper trailer hitch. Do not tow by attaching a rope or cable to the vehicle's frame.
- Secure all items inside the trailer so they cannot shift while driving.

⚠ WARNING

Exceeding a load limit or improperly towing a trailer can cause a crash in which you can be seriously hurt or killed.

Follow all load limits and towing guidelines in this owner's manual.

Basic Operation & Driving Guidelines

This section gives information on how to start and stop your engine. It also provides guidelines for operating on different types of terrain, driving with cargo, and towing a trailer.

| | |
|--------------------------------------|----|
| Basic Operation | 62 |
| Starting & Stopping the Engine..... | 62 |
| Shifting Gears..... | 64 |
| Riding in Reverse | 67 |
| Selecting a Drive Mode | 68 |
| Parking..... | 69 |
| Driving Guidelines | 70 |
| Safe Driving Precautions | 70 |
| Off-road Driving Considerations..... | 72 |
| Basic Driving | 74 |
| Driving on Hills | 75 |
| Driving Through Water | 78 |
| Driving at Night | 78 |

Basic Operation

Starting & Stopping the Engine

For safety, we recommend that you start the engine in a well-ventilated area. If that is not practical, move the vehicle outdoors as soon as possible. The engine's exhaust contains carbon monoxide, a colorless and odorless gas that can cause illness and even death.

WARNING

Engine exhaust contains toxic carbon monoxide, a colorless and odorless gas. Breathing it can cause unconsciousness and even kill you.

If you must start the engine in a poorly ventilated area, move it outdoors immediately.

The starter motor will operate when the transmission is in neutral or the brake pedal is pressed. You should do the following checks and adjustments before you drive your vehicle.

Before START:

1. Make sure the doors, side nets and front hood are securely closed.
2. Check that any items you may be carrying are stored properly or fastened down securely.
3. Fasten your seat belt. Check that your passenger has fastened their seat belt as well.
4. When you start the engine, check the indicators in the instrument panel.

Basic Operation

Starting the engine:

1. Apply the parking brake.
2. Press on the brake pedal. Insert the key and turn the ignition switch to the ON (I) position. Confirm the transmission is in neutral, and the neutral indicator is on.
3. To start the engine, without touching the accelerator pedal, turn the ignition switch to the START (II) position. Immediately after the engine starts, let go of the key. The switch returns to the ON (I) position.
Do not hold the key in the START (II) position for more than 5 seconds at a time.
If the engine does not start after 5 seconds, turn the key back to the OFF (O) position and wait about 10 seconds before turning it to START (II) again.
4. If the engine does not start within 5 seconds, or starts but stalls right away, repeat step 3 with the accelerator pedal pressed halfway down.
If the engine starts, release pressure on the accelerator pedal so the engine does not race.
5. If the engine fails to start, press the accelerator pedal all the way down, and hold it there while starting to clear flooding. If the engine still does not start, return to step 3.

The engine can be started with the transmission in gear, the engine will start in gear if the unit is completely stopped, and the brake pedal is pressed.

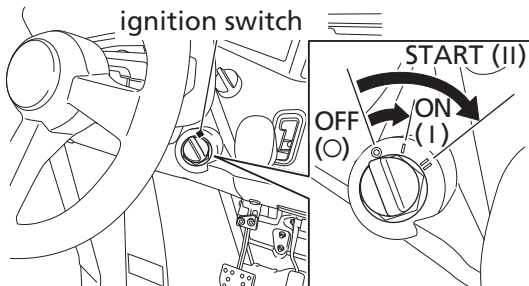

Basic Operation

To stop the engine, turn the ignition switch to the OFF (O) position. Remember to apply the parking brake and remove the key if you plan to leave the vehicle.

Shifting Gears

GEAR SHIFTING SEQUENCE

downshift paddle

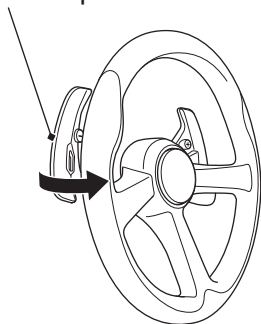

upshift paddle

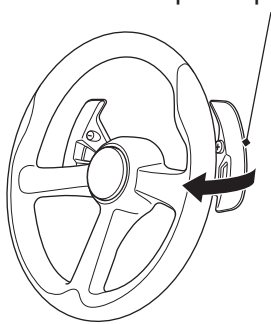

Your SXS has five forward gears (L,2,3,4 and 5) and one reverse gear (R).

Two gear shift paddles are located behind the steering wheel: Downshift (left paddle) and Upshift (right paddle).

To upshift the transmission, pull the right side upshift paddle once. To downshift the transmission, pull the left side downshift paddle once.

Basic Operation

After starting the engine and letting it warm up, follow this procedure:

1. With the transmission in neutral, release the parking brake, but continue to press the brake pedal.
2. With the throttle closed, pull the upshift paddle once to shift into L (low) gear.
3. Release pressure from the brake pedal and increase engine speed by gradually pressing the accelerator pedal.
4. When speed increases, shift to 2nd gear by pulling the upshift paddle once. Lifting off the throttle is recommended, but not required.
5. Repeat this sequence to progressively upshift to 3rd, 4th and 5th (top) Gear.
6. To downshift, pull the downshift paddle once. Remember to lift off the throttle each time you shift to the next lower gear.

The transmission cannot be upshifted from neutral to L gear when the engine speed is above 3,000rpm or the ground speed is above 2 mph (3 km/h).

If the electric shift system malfunctions, the transmission cannot be shifted by pulling the gearshift paddles, See your dealer. (In emergency, a gear may be selected manually so you may move the vehicle. See *Emergency Gear Selection & Operation* on page 188.)

(cont'd)

Basic Operation

Recommended Shift Points - For General Riding

Ride in the highest gear that lets the engine run and accelerate smoothly. This will give you good fuel efficiency and effective emissions control.

| Shifting Up | MPH | KPH |
|--------------------|------------|------------|
| From L to 2nd | 4 | 6 |
| From 2nd to 3rd | 6 | 10 |
| From 3rd to 4th | 9 | 15 |
| From 4th to 5th | 13 | 21 |

| Shifting Down | MPH | KPH |
|----------------------|------------|------------|
| From 5th to 4th | 9 | 15 |
| From 4th to 3rd | 7 | 11 |
| From 3rd to 2nd | 4 | 7 |
| From 2nd to L | 3 | 4 |

NOTICE

Improper shifting can damage the engine, transmission, and drive train. Also, coasting or towing the SxS for long distance with the engine off can damage the transmission.

Basic Operation

Riding in Reverse

If you need to drive in reverse, make sure the area behind you is clear and only operate the SXS at low speed.

1. Bring the SXS to complete stop (the transmission cannot be shifted into reverse if the vehicle is moving). Make sure the transmission is in neutral.
2. Be sure there are no obstacles or people in the way.
3. While pulling the reverse lever and depressing the brake pedal, pull the downshift paddle once to shift into "R" (reverse) gear.

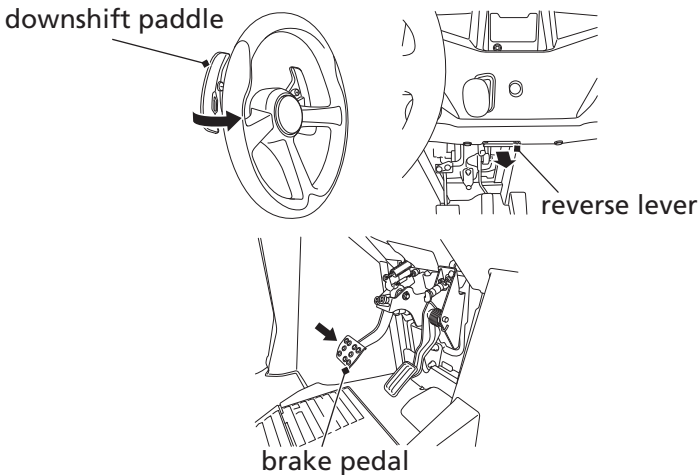

4. Make sure that the reverse indicator comes on.
5. Release the brake pedal and reverse lever.
6. Press the accelerator pedal gradually to increase speed.
7. To stop, lift off the accelerator pedal and press the brake pedal.
8. To shift out of reverse and into neutral, pull the upshift paddle once to shift into "N" (neutral) gear. Make sure that the reverse indicator goes off.

Basic Operation

To stop the engine, turn the ignition switch to the OFF (O) position. Remember to apply the parking brake and remove the key if you plan to leave the vehicle.

Selecting a Drive Mode

- 2WD** This mode supplies power to the rear wheels only, this mode is best for surfaces with good traction.
- 4WD** This mode supplies power to the front and rear wheels. Steering will require slightly more effort than with 2WD. This mode is recommended for driving on surfaces with poor traction.

Before using the drive mode select lever to change from one mode to another, be sure the vehicle is stopped and the engine is idling. See page 33 for additional information.

Basic Operation

Parking

Look for a level parking area with a firm surface. Avoid parking on a slope or on loose or slippery surfaces when possible. If you must park on a slope, block the wheels to help keep the vehicle from sliding.

After bringing your vehicle to a stop:

1. Keep your foot on the brake pedal while you shift into neutral (N).
2. Set the parking brake.
3. Turn the ignition switch to the OFF (O) position, and remove the key.

Fully push the parking brake lever down when releasing the parking brake.

Driving Guidelines

Your Honda SXS has been designed with many safety features to help protect you. These include a strong occupant protection structure, seat belts, doors, and side nets. However, no safety system can prevent all injuries.

The following pages contain important precautions and driving guidelines to help you make good decisions and operate your vehicle safely.

WARNING

Failure to follow the driving guidelines in this owner's manual can lead to a crash or overturn in which you or others can be seriously hurt or killed.

Follow all safe-driving guidelines in this owner's manual.

Safe Driving Precautions

Before driving your Honda SXS for the first time, please review the "Driver & Passenger Safety" section (page 1), the "Before Driving" section (page 49), and the precautions below.

We also recommend that you complete the Recreational Off-Highway Vehicle (ROV) E-Course. The free course is available at www.ROHVA.org. The two-hour ROV E-Course is a multi-media, interactive, online safety course that reinforces:

- Key risk factors associated with ROV operation
- Safe driving practices that will reduce risk of injury
- The best resources for learning about your particular vehicle

Driving Guidelines

The ROHVA (Recreational Off-Highway Vehicle Association) also offers the hands-on ROV Basic Driver Course (RBDC). Information on and registration for the RBDC is available at www.ROHVA.org.

Off-highway Use Only

Your Honda SXS was designed for use on a wide variety of terrain and situations. However, it should not be driven on any public road, paved or unpaved, because it is not equipped to legally or safely drive on such roads.

Remember to obey all local off-road regulations, obtain permission before driving on someone else's private property, and respect all "no trespassing" signs.

Control Speed

Driving at excessive speed for the terrain or other conditions increases the chance of a crash or overturn. Always reduce speed when driving on hilly terrain, or when carrying cargo or towing a trailer.

Use Extra Care on Unfamiliar Terrain

When driving in a new area, keep your speed low and check the terrain ahead for possible problems, such as large rocks, bumps, holes, or drop-offs. Don't drive fast on unfamiliar terrain or when visibility is limited. If you drive in an area with other vehicles, be sure to keep a safe distance to avoid a collision.

Do Not Perform Stunts

Keep all four wheels on the ground at all times. Showing off or attempting to perform stunts could lead to a crash or overturn in which the driver, a passenger, or others could be seriously hurt or killed.

Driving Guidelines

Off-road Driving Considerations

Your Honda SXS was designed and intended for off-road use. In the event that you must drive on a paved surface, be aware that your Honda SXS will feel and handle different than it does on dirt. The tires will also wear much faster.

Vehicle Design

The Honda SXS handles somewhat differently from on-highway vehicles due in part to features that allow it to perform its role as an off-highway utility vehicle. For example, Honda SXS has a higher center of gravity than cars designed for use only on pavement. It is also equipped with large low-pressure tires that allow good traction in sand, loose dirt, wet grass and other low-traction surfaces.

These advantages come at some cost. Because your vehicle is taller and rides higher off the ground, it can more easily tip or roll over if you make abrupt turns or drive on sloped terrain.

Off-highway Environments

Driving on private property, or in approved off-highway areas, means you leave a generally predictable and orderly world behind. You won't find lane markers or traffic signals, and no one will be there to warn you of trouble ahead. It's up to you to assess situations and drive within limits. The terrain has limits (it may be too steep or bumpy, for example). The vehicle has limits (e.g., traction, stability, and power). And you may be limited by lack of experience.

Driving Guidelines

Surface Considerations

The kind of surface you drive on can have important effects on how your vehicle handles. For example, on loose or soft surfaces you'll need more time and distance to accelerate, turn, or brake to a stop.

Avoid any sudden sharp turn, particularly on pavement and other hard surfaces. And always slow down after moving from one type of surface to another until you get accustomed to how your vehicle handles.

Reading the Terrain

Because visual information comes in unpredictable ways off-road, you need to stay alert, constantly survey the terrain, and go slow enough to analyze situations and make good decisions.

As your eyes search the terrain ahead, watch for changes in surface conditions. One minute you can be on firm soil and the next in soft sand or deep mud. A path can quickly change from level to bumpy, slope at a dangerous angle, or disappear in a drop-off. Always keep your eyes open for holes, washouts, or obstacles that could upset or damage the vehicle.

Of course if you cannot see clearly, due to tall grass for example, stop safely, get out of the vehicle, and survey the area for a safe route.

Controlling Speed

Whether you travel off-road or on pavement, the general rule is to keep your speed low. Of course, you'll need enough speed to keep moving forward, but too much speed leads to problems.

When driving off-road at higher speeds, you have less time to read the terrain and make good decisions. The drive can also be more bumpy, and there's a greater chance of the vehicle sliding if you brake or turn quickly on wet soil, gravel, or another slippery surface. Never go faster than conditions allow.

(cont'd)

Driving Guidelines

Driving with Cargo or Pulling a Trailer

The added weight of carrying cargo or pulling a trailer will affect how your vehicle accelerates, brakes, and handles. The added weight and length of a trailer will affect your directional control.

Please follow these guidelines whenever you carry cargo or pull a trailer:

- Do not exceed the cargo limit and towing limits (see page 57 for loading cargo and page 59 for towing a trailer).
- Keep speed low, particularly when driving on hills.
- Allow extra distance to accelerate, turn and slow or stop.
- Do not drive across a steep slope with a trailer.
- Use lower gears when towing a trailer or carrying extra cargo.

Basic Driving

Making Turns

The basic turning technique for Honda SXS is to drive at low speed and gradually adjust the amount of steering to suit the surface. Do not make sudden sharp turns, either off-road or on pavement.

If your vehicle ever skids sideways during a turn, steer in the direction of the skid. Also, avoid hard braking or accelerating until you have regained directional control.

Braking

The best off-road braking technique is to gently step down on the brake pedal, then increase pressure as more braking is needed. Light braking may be all you need on soft surfaces, such as sand or loose dirt. Avoid hard braking on any surface.

Driving Guidelines

Driving on Hills

Hills present some of the greatest challenges and hazards, especially if you are carrying cargo or pulling a trailer. If you are new to off-road driving, start with gentle inclines, take time to learn how your vehicle handles on slopes, and read the information that follows.

Even if you have previous off-road driving experience, the guidelines below should serve as important reminders.

Approaching a Hill

When you approach a hill, you need to decide whether it is one that you, your passenger, your cargo and your vehicle can handle. For example, ask yourself:

- Is the hill too steep? Is the incline constant, or are there places where it gets suddenly steeper? If you run out of power, you may not be able to continue forward.
- Is there enough traction for you to make it to the top without spinning the wheels or sliding backwards?
- Are there obstacles, such as rocks or ruts, that could upset your vehicle and make it roll over?
- If there is no safe predetermined path, can you drive straight up the hill without turning?
- Do you know what is on the other side of the hill?

If you do not know the answers to these questions before beginning an ascent, you should stop and walk up the hill to find out.

(cont'd)

Driving Guidelines

Driving Up a Hill

If you decide that it is safe to drive your Honda SXS up a hill:

- Select an appropriate gear and drive mode for the hill.
- Approach the hill with enough speed to smoothly start up the hill.
- Maintain a steady speed as you climb the hill.
- Reduce speed as you approach the top, and watch for other vehicles that may be approaching the top from the other side of the hill.

If You Stall Going Up a Hill

If a hill is steeper than you expected, traction is poor, or you don't maintain sufficient speed, you may begin to stall. If that happens:

- Stop the vehicle and set the parking brake.
- If you have a passenger, you may want to have them get out and move away from the vehicle.
- If you are headed straight up the hill, shift into reverse, release the parking brake, and slowly back straight down the hill, gently using the brake pedal to control speed.

Driving Down a Hill

Before driving down a hill, as with driving up a hill, you need to evaluate whether you can make it safely to the bottom and away from the slope.

Ask yourself:

- Is the hill too steep to maintain speed and steering control?
- Is the surface too rough or too slippery?
- Can you drive straight down without turning?
- Is there a safe exit when you reach the bottom of the hill?

Driving Guidelines

If you decide it is safe to drive down a hill:

- Hold the steering wheel firmly and drive straight back down the hill.
- Gently apply the brakes to help control speed, but do not “ride” the brakes.

Crossing a Hill

Before traversing a hill, consider these facts:

- A hill that you can drive straight up or down can be too steep to drive across.
- When you drive straight up or down a slope, the length of the wheelbase reduces the chance of tipping over backward or forward, but when you drive across a slope, the vehicle’s narrower track and higher center of gravity increases the chance of tipping or rolling over.
- If you drive across a slope and an uphill wheel hits a bump, or a downhill wheel drops into a hole, your vehicle will tip downward even more.

If you can’t clearly see all terrain conditions (good traction, no bumps, holes or other obstacles, etc.), stop and walk the slope before you drive on it. If you have any doubt whether you can safely drive across a slope, don’t do it. Find another route.

Avoiding Obstacles

When driving off-road, always watch for bumps, pot holes, rain ruts and other obstacles. Large bumps and holes can bounce you around and cause you to lose control or get stuck. Slow down whenever you drive on rough terrain.

Driving Guidelines

Driving Through Water

Before driving through water, stop and make sure that:

- The water is not more than about 10 inches (25 cm) deep.
- The water is not flowing too fast. Deep rushing water can sweep you downstream. Even very shallow rushing water can wash the ground from under your tires and cause you to lose traction and possibly roll over.
- Both banks have gradual slopes and good traction, so you can enter the stream and exit safely.
- The surface under the water appears to provide good traction. Remember, the water may hide hazards, such as rocks, holes, mud, or slippery vegetation.

If you decide you can safely cross the water:

- Proceed at a slow, steady speed.
- Watch for submerged obstacles, including slippery rocks and holes.
- Avoid getting the spark plug or air cleaner wet, as this would cause the engine to stop.

Driving at Night

If you drive your Honda SXS at night, always drive slower and more cautiously than you would in daylight.

Servicing Your Honda

To help keep your Honda SXS in good shape, this section includes a Maintenance Schedule for required service and step-by-step instructions for specific maintenance tasks. You'll also find important safety precautions, information on fuels and oils, and tips for keeping your Honda looking good.

For information about replacing fuses, see page 195.

(USA & Canada only)

For information about the exhaust emission and noise requirements of the U.S. Environmental Protection Agency (EPA), the California Air Resources Board (CARB), and Environment Canada (EC), see page 214.

USA Only

Maintenance, replacement or repair of the emission control devices and systems may be performed by any off-road utility vehicle repair establishment or individual using parts that are "certified" to EPA standards.

Before You Service Your Honda

| | |
|-------------------------------------|----|
| The Importance of Maintenance | 81 |
| Maintenance Safety | 82 |
| Important Safety Precautions | 83 |
| Maintenance Schedule | 84 |
| Maintenance Record..... | 89 |

Service Preparations

| | |
|---------------------------------------|----|
| Maintenance Component Locations | 90 |
| Tool Kit | 95 |
| Owner's Manual Storage | 96 |
| Front Hood..... | 97 |
| Seat Bottom Removal | 98 |

(cont'd)

Servicing Your Honda

| | |
|-------------------------------------|-----|
| Seat Back Removal | 99 |
| Center Rear Panel Removal | 100 |
| Clip Removal | 101 |
| Jack Up Point & Support Point | 102 |

Service Procedures

Fluids, Filters & Lubricants

| | |
|----------------------------|-----|
| Fuel | 103 |
| Engine Oil & Filter | 106 |
| Front Final Gear Oil | 116 |
| Rear Final Gear Oil | 118 |
| Coolant | 120 |
| Air Cleaner | 125 |
| Lubrication | 130 |

Engine

| | |
|--------------------------------|-----|
| Accelerator Pedal | 133 |
| Reverse Inhibitor System | 135 |
| Spark Plug | 137 |
| Spark Arrester | 140 |
| Exhaust System | 141 |

Chassis

| | |
|------------------------|-----|
| Suspension | 142 |
| Brakes | 146 |
| Tires | 153 |
| Wheels | 160 |
| Driveshaft Boots | 161 |

Electrical

| | |
|---------------|-----|
| Battery | 162 |
|---------------|-----|

| | |
|-----------------------|-----|
| Appearance Care | 167 |
|-----------------------|-----|

The Importance of Maintenance

A well-maintained Honda SXS is essential for safe, economical, and trouble-free operation. It will also help reduce air pollution. Careful pre-drive inspections and good maintenance are especially important because your Honda SXS is designed to be driven over rough off-road terrain.

To help you properly care for your Honda SXS, this section of the manual provides a Maintenance Schedule. The service intervals in this schedule are based on average operation conditions.

WARNING

Improperly maintaining this Honda SXS or failing to correct a problem before you drive can cause a crash in which you can be seriously hurt or killed.

Always follow the inspection and maintenance recommendations and schedules in this owner's manual.

Frequent servicing of the air cleaner is especially important to help you avoid a possible costly engine repair.

If your Honda SXS overturns or is involved in a crash, be sure your dealer inspects all major parts, even if you are able to make some repairs.

Maintenance Safety

This section includes instructions on how to perform some important maintenance tasks. If you have basic mechanical skills, you can perform many of these tasks with the tools provided with your Honda SXS.

Other tasks that are more difficult and require special tools are best performed by professionals. Removing the wheels should normally be handled only by a Honda technician or other qualified mechanic. Instructions are included in this manual only to assist in emergency service.

Some of the most important safety precautions follow. However, we cannot warn you of every conceivable hazard that can arise in performing maintenance. Only you can decide whether or not you should perform a given task.

WARNING

Failure to properly follow maintenance instructions and precautions can cause you to be seriously hurt or killed.

Always follow the procedures and precautions in this owner's manual.

Maintenance Safety

Important Safety Precautions

- Make sure the engine is off before you begin any maintenance or repairs. This will help eliminate several potential hazards:
 - Carbon monoxide poisoning from engine exhaust.** Be sure there is adequate ventilation whenever you operate the engine.
 - Burns from hot parts.** Let the engine and exhaust system cool before touching.
 - Injury from moving parts.** Do not run the engine unless instructed to do so.
- Read the instructions before you begin, and make sure you have the tools and skills required.
- To reduce the possibility of a fire or explosion, be careful when working around gasoline. Use only non-flammable solvent, not gasoline, to clean parts. Keep cigarettes, sparks, and flames away from all fuel-related parts.

Remember that your Honda dealer knows your Honda SXS best and is fully equipped to maintain and repair it. To ensure the best quality and reliability, use only new Honda Genuine Parts or other equivalents for repair and replacement. If you have the tools and skills required for additional maintenance jobs, you can purchase an official Honda Service Manual (page 224).

Maintenance Schedule

The required Maintenance Schedule that follows specifies how often you should have your Honda SXS serviced, and what things need attention. It is essential to have your Honda SXS serviced as scheduled to maintain safe, dependable performance, and proper emission control.

The service intervals in this Maintenance Schedule are based on average driving conditions. Some items will need more frequent service if you drive in unusually wet or dusty areas or at full throttle. Consult your dealer for recommendations applicable to your individual needs and use.

Some items in the Maintenance Schedule can be performed with basic mechanical skills and hand tools. Procedures for these items are provided in this manual. Other items involve more extensive procedures and may require special training, tools, and equipment. We recommend that you have your dealer perform these tasks unless you have advanced mechanical skills and the required tools and equipment. Procedures for such items in this schedule are provided in an official Honda Service Manual available for purchase (page 224).

If you do not feel capable of performing a given task or need assistance, remember that your Honda dealer knows your Honda SXS best and is fully equipped to maintain and repair it. If you decide to do your own maintenance, use only Honda Genuine Parts or their equivalents for repair or replacement to ensure the best quality and reliability.



Maintenance Schedule

Perform the pre-ride inspection (page 54) and owner maintenance in this section at each scheduled maintenance period.

Maintenance Minder Messages on the Multi-function Display

The maintenance minder indicator appears in the multi-function display when the mileage or operating hours on your Honda SXS reaches the maintenance interval specified on the maintenance schedule.

Maintenance Minder Indicators:

| | |
|---|---|
|  | Initial Maintenance Appears at 100 miles (150 km) or 20 operating hours, whichever comes first. See <i>Initial Maintenance</i> on the maintenance schedule. |
|  | Regular Maintenance Interval 1 Appears 600 miles (1,000 km) or 100 operating hours after the Initial Maintenance is performed and maintenance minder is reset (page 28). See <i>Regular Maintenance Interval</i> for 100, 300, and 500 operating hours (or corresponding mileage interval, whichever comes first) in the maintenance schedule. |
|  | Regular Maintenance Interval 2 Appears 600 miles (1,000 km) or 100 operating hours after Regular Maintenance Interval 1 is performed and maintenance minder is reset (page 28). See <i>Regular Maintenance Interval</i> for 200, 400, and 600 operating hours (or corresponding mileage interval, whichever comes first) in the maintenance schedule. |

Maintenance Schedule

- The Initial Maintenance indicator appears only once over the life of the vehicle.
- The Regular Maintenance Interval 1 and 2 indicators will appear alternately over the life of the vehicle.
- Consider the total mileage and operating hours shown on the odometer/hourmeter, along with your vehicle maintenance history, to determine the appropriate Regular Maintenance Interval to follow on the maintenance schedule.

Each item on the maintenance schedule requires some mechanical knowledge. Certain items (particularly those marked * and **) may require more technical information and tools. Consult your dealer.

- * Should be serviced by your dealer, unless you have the proper tools and service data, and are mechanically qualified. Refer to the official Honda Service Manual (page 224).
- ** In the interest of safety, we recommend these items be serviced only by your dealer.

Summary of Maintenance Schedule Notes:

NOTES:

- Note 1 Service more frequently when operating in dusty areas, sand or snow.
- Note 2 Service more frequently when operated in muddy, very wet conditions, or freezing temperatures.
- Note 3 Service more frequently when operated in muddy conditions.
- Note 4 Check the underbody whenever the under guard has been hit.

Maintenance Schedule

| Service the items listed at the indicated distance (or time, if given). | | | | | | | | | | | |
|---|---------|--|---|-----|-----|-----|-----|-----|----------|---------------|-----|
| | | Initial maintenance | Regular maintenance interval | | | | | | | | |
| FREQUENCY (Whichever comes first) | x100 mi | 1 | 6 | 12 | 18 | 24 | 30 | 36 | Note | Refer to page | |
| | x100 km | 1.5 | 10 | 20 | 30 | 40 | 50 | 60 | | | |
| | Hours | 20 | 100 | 200 | 300 | 400 | 500 | 600 | | | |
| ITEMS | Month | 1 | 12 | | | | | | | | |
| Check engine oil and coolant | | Check oil and coolant at fuel stop | | | | | | | 109, 121 | | |
| Check tires | | Check inflation and condition once a month | | | | | | | 154 | | |
| Check side net adjustment and snap hooks | | ● | ● | ● | ● | ● | ● | | 38 | | |
| * Reverse inhibitor system | | ● | ● | ● | ● | ● | ● | | 135 | | |
| Check brake fluid | | Check fluid level once a month | | | | | | | 147 | | |
| Replace engine oil and oil filter | | ● | ● | ● | ● | ● | ● | | 111 | | |
| * Inspect valve clearance | | ● | Every 600 miles (1,000 km) or 100 operating hours, otherwise adjust only if noisy | | | | | | | — | |
| * Clean spark arrester | | | Every 600 miles (1,000 km) or 100 operating hours, whichever comes first | | | | | | | 140 | |
| Clean air cleaner elements | | | | | | | | | | 1 | 126 |
| Check air cleaner housing drain tube | | | | | | | | | | 2 | 129 |
| Check spark plug | | | | | | | | | | | 137 |
| * Inspect idle speed | | ● | | | | | | | — | | |
| * Check fuel lines and connections | | | | ● | | ● | | | — | | |
| Check front and rear brakes | | ● | | | ● | | | 3 | 146 | | |
| Check front and rear final gear oil | | ● | | | ● | | | | 116, 118 | | |

* Should be serviced by your dealer, unless you have the proper tools and service data, and are mechanically qualified. Refer to the official Honda Service Manual (page 224).

Note 1 Service more frequently when operating in dusty areas, sand or snow.

Note 2 Service more frequently when operating in muddy, very wet conditions, or freezing temperatures.

Note 3 Service more frequently when operated in muddy conditions.

Maintenance Schedule

| Service the items listed at the indicated distance (or time, if given). | | | | | | | | | | |
|---|---|---------------------|------------------------------|-----|-----|-----|-----|-----|------|---------------|
| | | Initial maintenance | Regular maintenance interval | | | | | | | |
| FREQUENCY (Whichever comes first) | x100 mi | 1 | 6 | 12 | 18 | 24 | 30 | 36 | Note | Refer to page |
| | x100 km | 1.5 | 10 | 20 | 30 | 40 | 50 | 60 | | |
| | Hours | 20 | 100 | 200 | 300 | 400 | 500 | 600 | | |
| ITEMS | Month | 1 | 12 | | | | | | | |
| | Lubricate all hinges, latches, and pivots | ● | ● | ● | ● | ● | ● | ● | | 130 |
| ** | Inspect the following items: | | | | | | | | | — |
| | Suspension components | | | | | | | | | — |
| | Wheels | | | | | | | | | 160 |
| | Driveshaft boots | | | | | | | | | 161 |
| | Accelerator and brake pedals | | | | ● | | | ● | | 133, 150 |
| | Brake light switch | | | | | | | | | 152 |
| | Exhaust system | | | | | | | | | 141 |
| | Battery terminal condition | | | | | | | | | 163 |
| | Check parking brake adjustment | ● | | | | | | ● | | 151 |
| ** | Inspect the following items: | | | | | | | | | — |
| | Tie-rod ends | | | | | | | | | — |
| * | Steering gearbox and boots | | | | | | | ● | | — |
| * | Brake hoses and lines | | | | | | | | | — |
| * | SXS underbody | | | | | | | | 4 | — |
| | Replace the following items: | | | | | | | | | — |
| | Front and rear final gear oil | | | | | | | | | 116, 119 |
| * | Engine coolant | | | | | | | | | 123 |
| * | Brake fluid | | | | | | | | | — |

* Should be serviced by your dealer, unless you have the proper tools and service data, and are mechanically qualified. Refer to the official Honda Service Manual (page 224).

** In the interest of safety, we recommend these items be serviced only by your dealer.

Note 4 Check the underbody whenever the under guard has been hit.

Maintenance Record

Keeping an accurate maintenance record will help ensure that your Honda SXS is properly maintained. Retain detailed receipts to verify the maintenance was performed. If the Honda SXS is sold, these receipts should be transferred with the Honda SXS to the new owner. Make sure whoever performs the maintenance completes this record. All scheduled maintenance, including the 100-mile (150 km) or 20 hours or 1-month initial maintenance, is considered a normal owner operating cost and will be charged for by your dealer. Use the space under Notes to record anything you want to remind yourself about or mention to your dealer.

| Miles (km) or hours | ODO or HOUR | Date | Performed By: | Notes |
|----------------------------|--------------------|-------------|----------------------|--------------|
| 100 (150) or 20 | | | | |
| 600 (1,000) or 100 | | | | |
| 1,200 (2,000) or 200 | | | | |
| 1,800 (3,000) or 300 | | | | |
| 2,400 (4,000) or 400 | | | | |
| 3,000 (5,000) or 500 | | | | |
| 3,600 (6,000) or 600 | | | | |
| 4,200 (7,000) or 700 | | | | |
| 4,800 (8,000) or 800 | | | | |

Maintenance Component Locations

- > Indicates something visible.
-> Indicates something concealed.

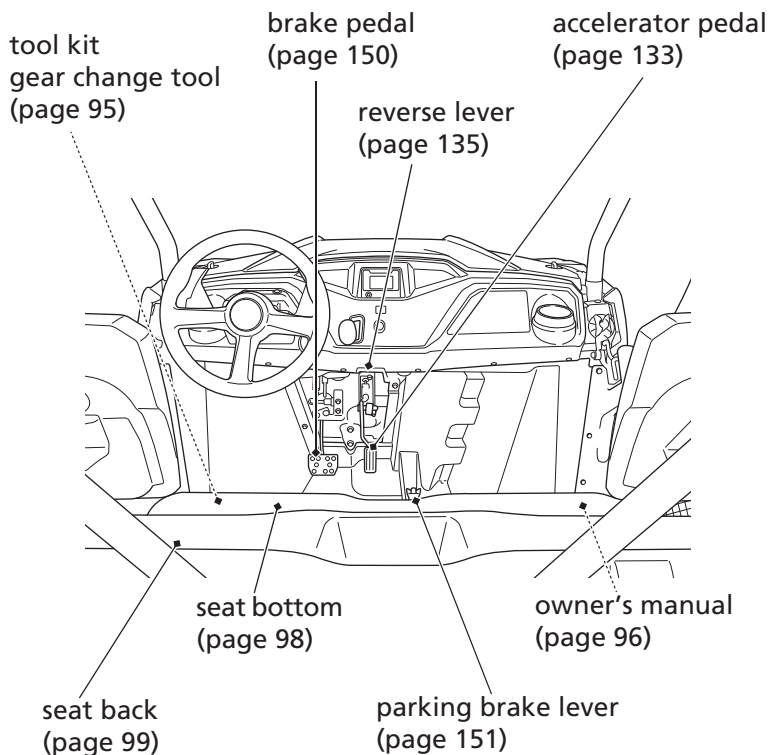

Maintenance Component Locations

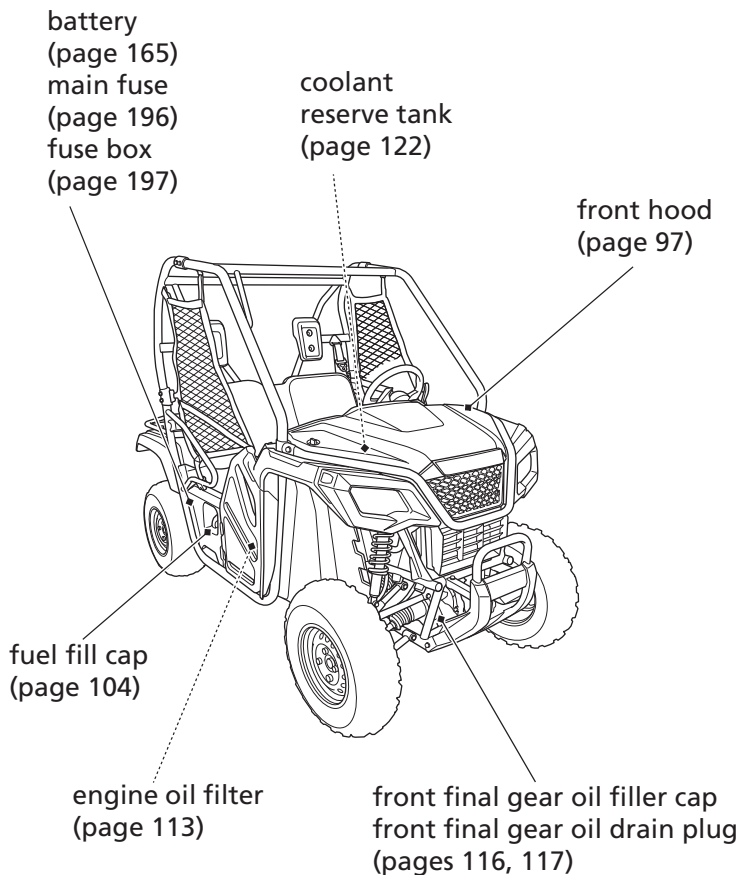

Maintenance Component Locations

- Indicates something visible.
-→ Indicates something concealed.

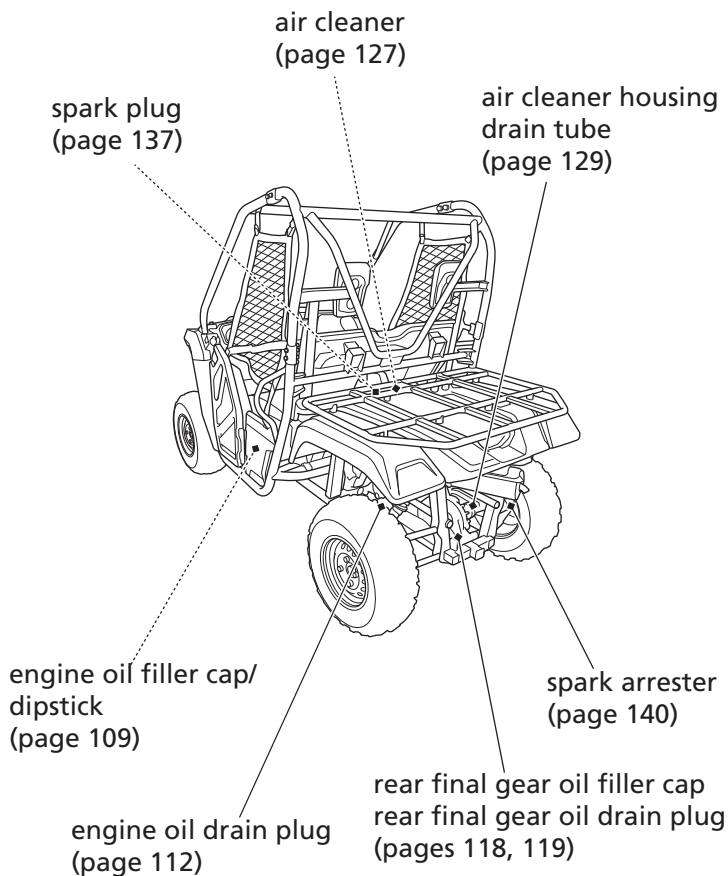

Maintenance Component Locations

front suspension spring
pre-load adjusters
(page 143)

brake light switch
(page 152)

brake fluid
reservoir tank
(page 147)

driveshaft boots
(page 161)

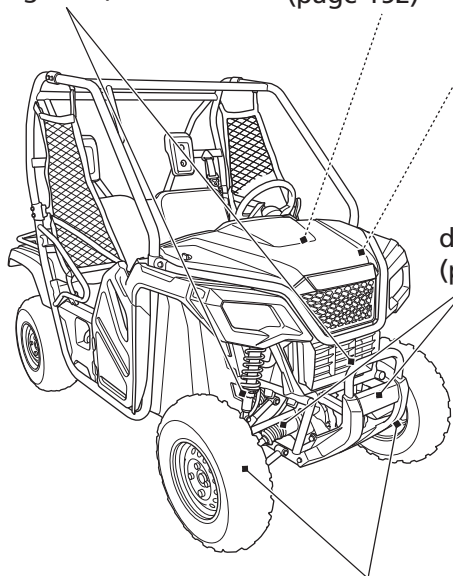

front brake calipers
(page 149)

Maintenance Component Locations

- Indicates something visible.
-→ Indicates something concealed.

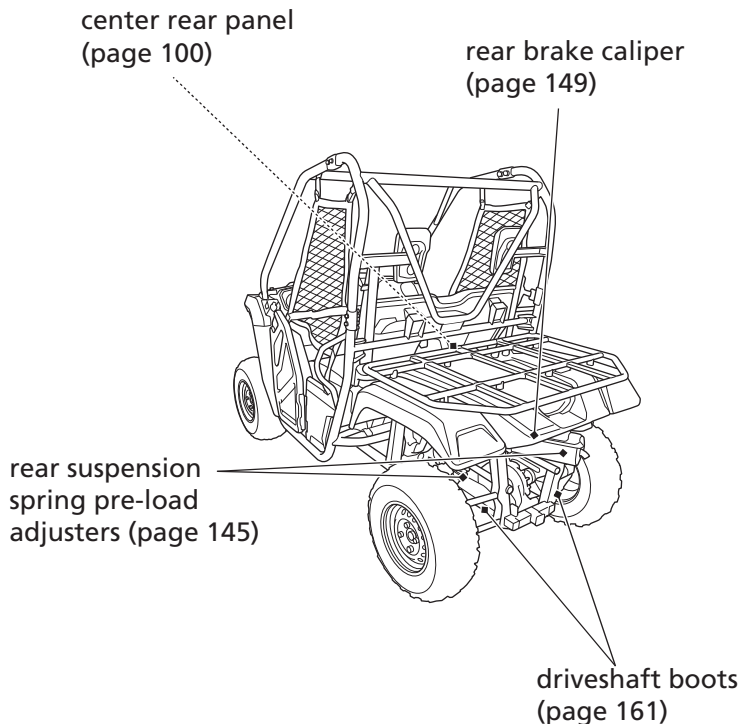

Tool Kit

The tool kit and the gear change tool are stored in the compartment under the seat bottom.

To access the tool kit and the gear change tool, remove the seat bottom (page 98).

An optional, larger tool kit may be available. Check with your dealer's parts department.

UNDER SEAT BOTTOM

LEFT SIDE

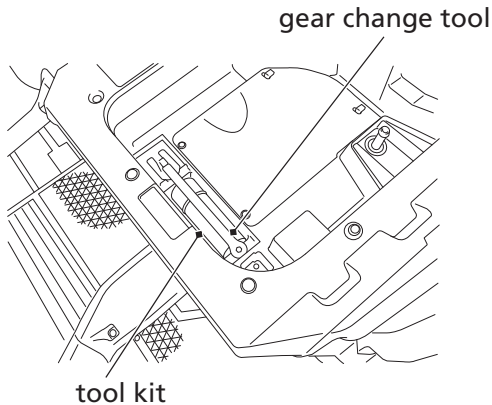

Owner's Manual Storage

Your Honda SXS provides storage for the owner's manual so you'll have it with you for easy reference. Store your owner's manual in the plastic document bag under the seat bottom.

The owner's manual should be stored in the plastic bag.

Be careful not to flood this area when washing your Honda SXS.

**UNDER SEAT BOTTOM
RIGHT SIDE**

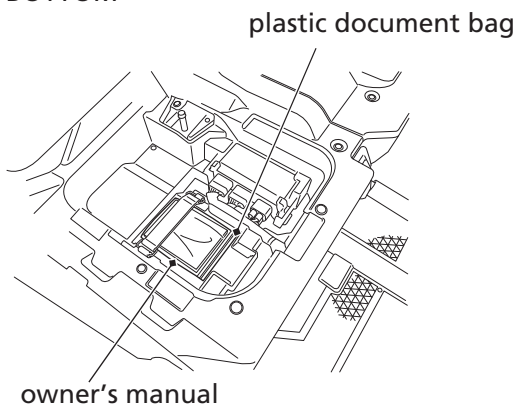

Front Hood

Refer to *Safety Precautions* on page 83.

The front hood must be removed to lubricate the drive mode select lever pivot, brake light switch adjustment, reverse inhibitor system adjustment and throttle cable adjustment, to check the coolant level and for washing the radiator fan area.

Removal

1. Turn the knobs outward.
2. Remove the prongs from the grommets.
3. Remove the front hood.

Installation

1. Insert the hooks into the slots.
2. Install the prongs into the grommets.
3. Turn the knobs inward.

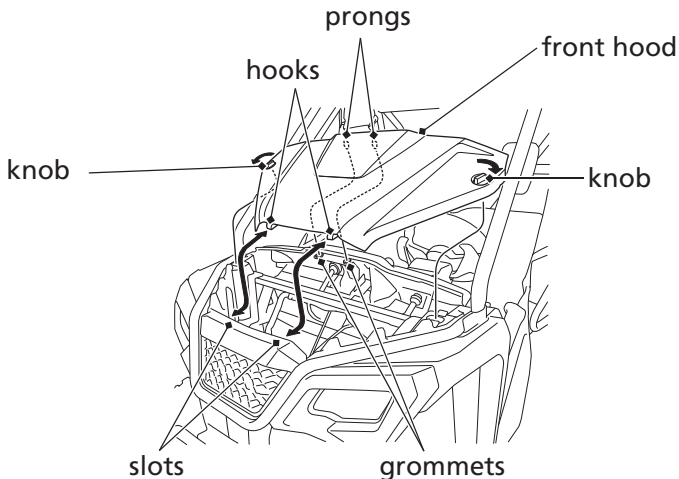

Seat Bottom Removal

Refer to *Safety Precautions* on page 83.

The seat bottom must be removed to check the engine oil level, to add engine oil, to change the engine oil filter, and to access the tool kit, gear change tool and owner's manual.

Removal

1. Open the doors (page 37).
2. Pull the rear of seat bottom upward then slide it slightly backward.

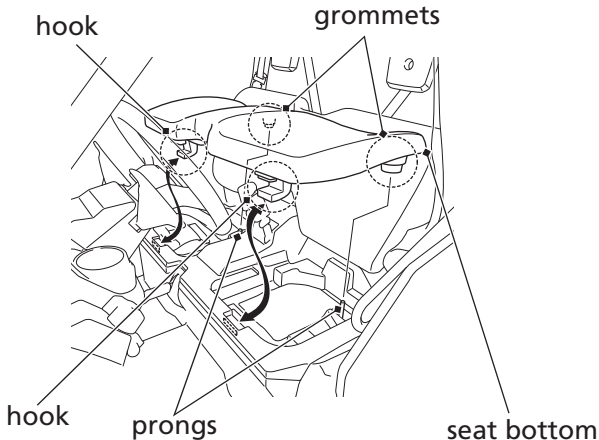

Installation

Insert the hooks into the frame and the prongs into the grommets of the seat bottom.

Seat Back Removal

Refer to *Safety Precautions* on page 83.

The seat back must be removed for spark plug maintenance, to change the engine oil filter, to clean the air cleaner, to remove the center rear panel.

Removal

1. Open the doors (page 37).
2. Pull the bottom of seat back forward then slide it slightly downward.

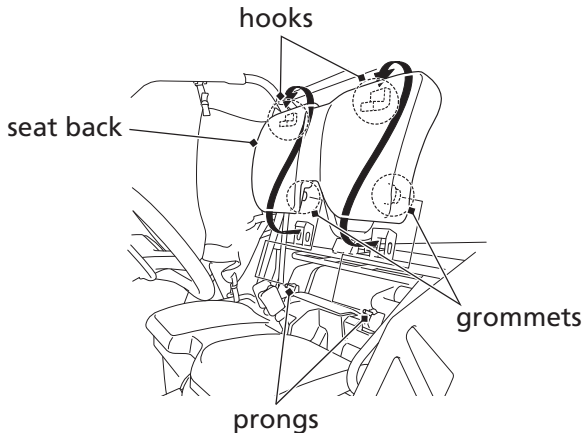

Installation

Insert the hooks into the frame and the prongs into the grommets of the seat back.

Center Rear Panel Removal

Refer to *Safety Precautions* on page 83.

The center rear panel must be removed for spark plug maintenance, to change the engine oil filter, to clean the air cleaner.

Removal

1. Remove the seat back (page 99).
2. Release the prongs from their grommets.
3. Pull the center rear panel forward.

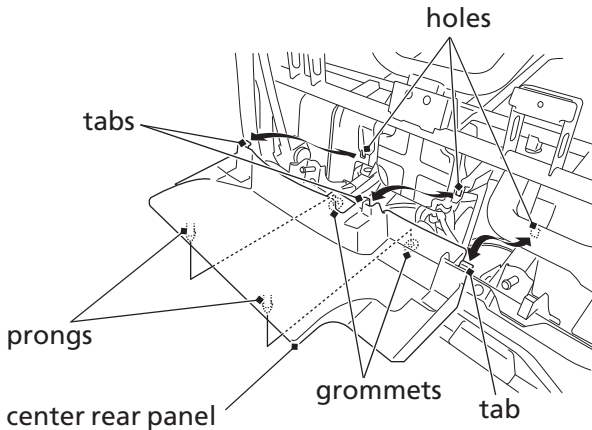

Installation

1. Insert the tabs into the holes.
2. Install the prongs into their grommets.
3. Install the center rear panel.

Clip Removal

Clip removal and installation:

Removal

1. Pull up the center pin to release the lock.
2. Pull out the clip of the hole.

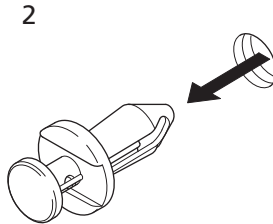

Installation

1. Insert the clip into the hole.
2. Press down the center pin securely to lock the clip.

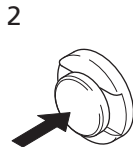
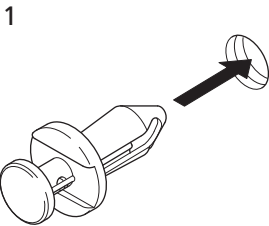

Jack Up Point & Support Point

Refer to *Safety Precautions* on page 83.

When jacking up and supporting this vehicle, the following jack-up points and support points should be used.

⚠ WARNING

The vehicle can easily roll off a jack, seriously injuring anyone underneath.

Follow the directions for changing a tire exactly, and never get under the vehicle when it is supported only by the jack.

When using a jack, always abide by the following instructions.

- Do not leave the engine running.
- Set the drive mode in 4WD mode and set the parking brake securely.
- Use only on a firm level surface.
- Place a jack only at the specified jack-up point.
- Do not leave any person or cargo in the vehicle.
- Do not place any object above or under a jack.

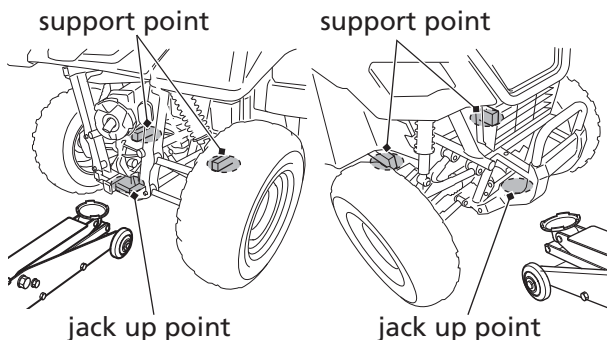

Refer to *Safety Precautions* on page 83.

Fuel Recommendation

| | |
|--------------------|----------------|
| type | unleaded |
| pump octane number | 86 (or higher) |

Use only unleaded fuel in your Honda. The use of leaded fuel will damage the catalytic converter(s). If you drive your Honda in a country where leaded fuel might be available, take precautions to use only unleaded fuel.

Your engine is designed to use any unleaded gasoline that has a pump octane number of 86 or higher. Gasoline pumps at service stations normally display the pump octane number. For information on the use of oxygenated fuels (USA & Canada only), see page 218.

For information on the use of *Petrol Containing Alcohol* (Australia & New Zealand only), see page 220.

Use of lower octane gasoline can cause persistent “pinging” or “spark knock” (a loud rapping noise) which, if severe, can lead to engine damage. Light pinging experienced while operating under a heavy load, such as climbing a hill, is no cause for concern.

If pinging or spark knock occurs at a steady engine speed under normal load, change brands of gasoline. If pinging or spark knock persists, consult your dealer.

Never use stale or contaminated gasoline or an oil/gasoline mixture. Avoid getting dirt, dust, or water in the fuel tank.

Fuel

Fuel Capacity

Fuel tank capacity:
3.96 US gal (15.0 ℓ)

When there is only one segment left in the fuel gauge (page 21), fuel will be low and you should refuel as soon as possible.

Refueling Procedure

Refer to *Safety Precautions* on page 83.

RIGHT SIDE

bottom of filler neck

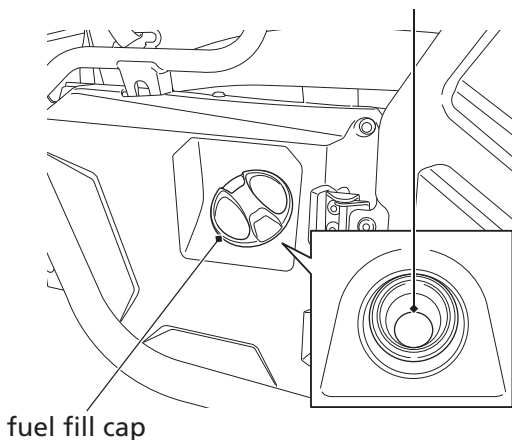

1. Turn the fuel fill cap counterclockwise.
2. Add fuel until the level reaches the bottom of the filler neck.
Avoid over filling the tank. There should be no fuel in the filler neck.

WARNING

Gasoline is highly flammable and explosive. You can be burned or seriously injured when handling fuel.

- Stop the engine and keep heat, sparks and flame away.
- Handle fuel only outdoors.
- Wipe up spills immediately.

3. After refueling, turn the fuel fill cap clockwise securely.

If you replace the fuel fill cap, use only a Honda Genuine replacement part.

NOTICE

Gasoline can damage the camouflage coating. Do not allow spilled gasoline to pool on camouflage colored bodywork. Also, do not allow gasoline soaked rags to be placed on camouflage bodywork.

Engine Oil & Filter

Engine oil quality is a major factor that affects both the performance and the service life of the engine.

Using the proper oil (page 107) and filter, and regularly checking, adding, and changing oil will help extend your engine's life. Even the best oil wears out. Changing oil helps get rid of dirt and deposits in the engine. Operating the engine with old or dirty oil can damage your engine. Running the engine with insufficient oil can cause serious damage to the engine and transmission.

Change the engine oil as specified in the maintenance schedule on page 87. When running in very dusty conditions, oil changes should be performed more frequently than specified in the maintenance schedule.

Engine Oil & Filter

Oil Recommendation

| | |
|---------------------|--|
| API classification | SG or higher except oils labeled as energy conserving or resource conserving on the circular API service label |
| viscosity (weight) | SAE 10W-30 |
| JASO T 903 standard | MA |
| suggested oil* | Pro Honda GN4 4-stroke oil (USA & Canada) or Honda 4-stroke oil, or an equivalent motorcycle oil. |

* Suggested oils are equal in performance to SJ oils that are not labeled as energy conserving or resource conserving on the circular API service label.

- Your Honda SXS does not need oil additives. Use the recommended oil.
- Do not use oils with graphite or molybdenum additives. They may adversely affect clutch operation.
- Do not use API SH or higher oils displaying a circular API “energy conserving” or “resource conserving” service label on the container. They may affect lubrication and clutch performance.



Not recommended

Recommended

- Do not use non-detergent, vegetable, or castor based racing oils.

Engine Oil & Filter

Other viscosities shown in the following chart may be used when the average temperature in your riding area is within the indicated range.

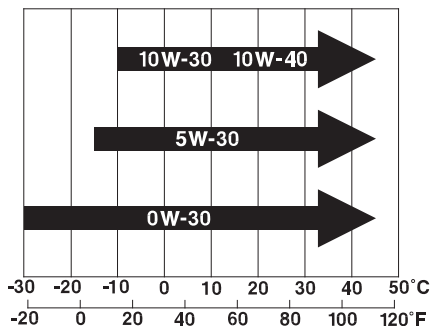

JASO T 903 standard

The JASO T 903 standard is an index for engine oils for 4-stroke motorcycle engines.

There are two classes: MA and MB.

Oil conforming to the standard is labeled on the oil container. For example, the following label shows the MA classification.

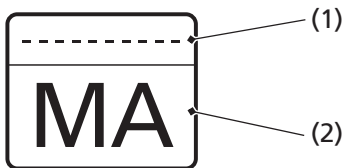

(1) oil code

(2) oil classification

Engine Oil & Filter

Checking & Adding Oil

Refer to *Safety Precautions* on page 83.

Check the engine oil level each day before operating your Honda SXS and add, if needed.

1. Park your Honda SXS on a firm, level surface.
2. Start the engine in a well-ventilated area and let it idle for 3 – 5 minutes. Stop the engine and wait 2 – 3 minutes.
3. Remove the seat bottom (page 98) and fold open the rubber dust cover on the left side.
4. Remove the oil filler cap/dipstick from the front crankcase cover and wipe it clean.
5. Insert the oil filler cap/dipstick without screwing it in, then remove the dipstick and check the oil level. The oil level should be between the upper level mark and the lower level mark on the dipstick.

UNDER SEAT BOTTOM

LEFT SIDE

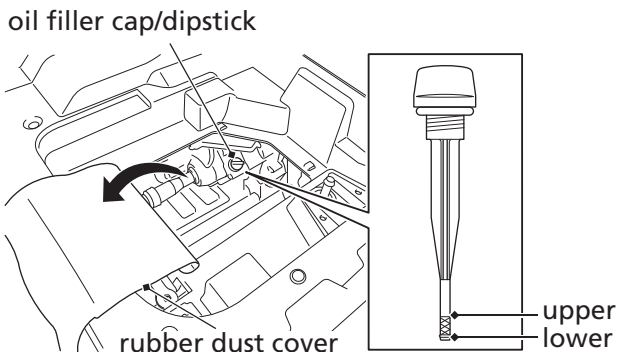

(cont'd)

Engine Oil & Filter

6. If required, add the specified oil into the fill cap hole, up to the upper level mark on the dipstick. Do not overfill.
7. Reinstall the oil filler cap/dipstick, rubber dust cover and seat bottom.

NOTICE

Running the engine with an improper oil level can cause serious engine damage.

Engine Oil & Filter

Changing Engine Oil & Filter

Refer to *Safety Precautions* on page 83.

Your Honda SXS's oil filter has very specific performance requirements. Use a new Honda Genuine oil filter specified for your model or a filter of equal quality.

NOTICE

Using the wrong oil filter may result in leaks, premature wear, or engine damage.

This procedure requires mechanical skill and professional tools such as a torque wrench, and access from underneath the vehicle, as well as the means for disposing of the drained fluid (page 180). If you do not have the skills or the tools, see your dealer.

Drain the Engine Oil:

1. Make sure the Honda SXS is parked on level ground. Set the parking brake, and jack up and support your Honda SXS (page 102).
2. Remove the seat bottom (page 98) and fold open the rubber dust cover.
3. Remove the oil filler cap/dipstick.

UNDER SEAT BOTTOM LEFT SIDE

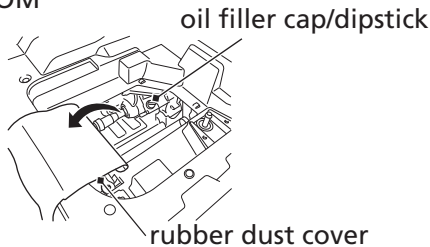

(cont'd)

Engine Oil & Filter

4. Place an oil drain pan under the crankcase.
5. Remove the engine oil drain plug and sealing washer.

UNDER BODY

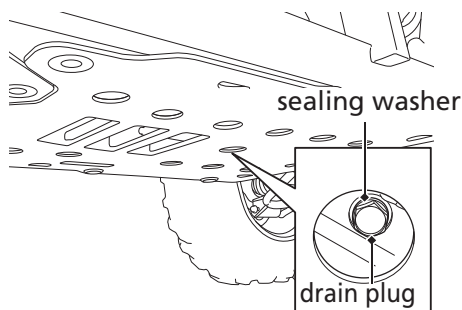

Install a New Engine Oil Filter:

6. Remove the seat back (page 99).
7. Remove the center rear panel (page 100).
8. Remove the clips (page 101) and screws from right seat bottom cover and flip it forward leaving ECU and wiring in place.
The oil filter can be accessed on right side of engine.

UNDER SEAT BOTTOM RIGHT SIDE

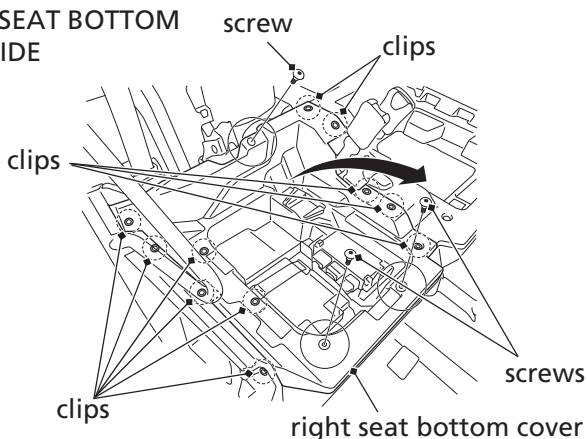

Engine Oil & Filter

9. Remove the oil filter cover by removing the bolts. Let the remaining oil drain out. Discard the oil filter in an approved manner.
10. Coat new O-rings with engine oil and install them into each groove in the filter cover and crank case.
11. Reposition the spring to the engine crankcase and install a new oil filter with the rubber seal facing out, away from the engine. You will see the "OUTSIDE (TOWARD FILTER COVER)" mark on the filter body, near the seal.
Use only the Honda Genuine oil filter or a filter of equivalent quality specified for your model.
Using the wrong Honda filter or a non-Honda filter which is not of equivalent quality may cause engine damage.

NOTICE

Improper installation of the oil filter can cause serious engine damage.

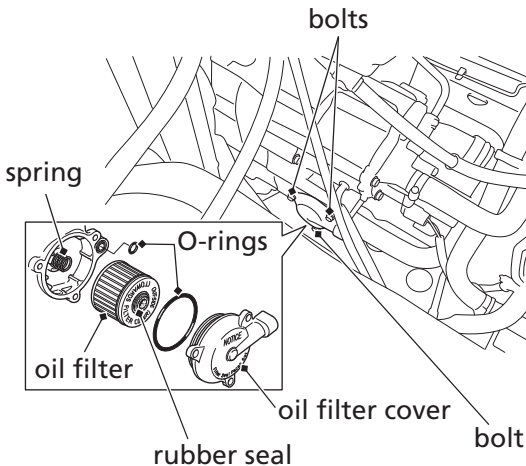

(cont'd)

Engine Oil & Filter

12. Reinstall the oil filter cover, making sure the bolts are tightened to the specified torque:

9 lbf·ft (12 N·m, 1.2 kgf·m)

13. Pour the drained oil into a suitable container and dispose of it in an approved manner (page 180).

NOTICE

Improper disposal of drained fluids is harmful to the environment.

14. Install the right seat bottom cover by flipping it back. Install the clips. Install the screws and tighten them to the specified torque:

5.9 lbf·ft (8 N·m, 0.8 kgf·m)

15. Install the center rear panel.

16. Install the seat back.

Engine Oil & Filter

Add Engine Oil:

17. Reinstall the drain plug with a new sealing washer, and tighten the drain plug to the specified torque:
18 lbf·ft (25 N·m, 2.5 kgf·m)
18. Lower your Honda SXS safely.
19. Fill the crankcase with the recommended oil, approximately:
3.2 US qt (3.0 ℓ)
20. Reinstall the oil filler cap/dipstick.
21. Reinstall the rubber dust cover.
22. Reinstall the seat bottom.
23. Start the engine and let it idle for 3 – 5 minutes.
24. Remove the seat bottom and fold open the rubber dust cover.
25. Stop the engine and after 2 – 3 minutes, check the oil level. Make sure the oil is between the upper and lower level marks on the dipstick. If necessary, add more oil but do not overfill.
26. Reinstall the oil filler cap/dipstick and rubber dust cover.
27. Reinstall the seat bottom.
28. Check that there are no oil leaks.

If a torque wrench is not used for installation, see your dealer as soon as possible to verify proper assembly.

Front Final Gear Oil

Oil Recommendation

| | |
|--------------------|---|
| API classification | GL-4 or GL-5 except oils labeled as energy conserving on the circular API service label |
| type | hypoid gear oil |
| viscosity (weight) | SAE 80W-90 |
| suggested oil | Honda shaft drive oil or equivalent |

Checking Oil

Refer to *Safety Precautions* on page 83.

Check the final gear oil level every 1,800 miles (3,000 km) or 300 hours of operating your Honda SXS and add, if needed.

1. Park your Honda SXS on a firm, level surface.
2. Remove the oil filler cap.
3. Make sure the oil level is at the lower edge of the oil filler inspection hole.
4. Apply a thin coat of grease to a new O-ring, and insert it into the oil filler cap groove.
5. Install and tighten oil filler cap to the specified torque:
9 lbf·ft (12 N·m, 1.2 kgf·m)

LEFT FRONT

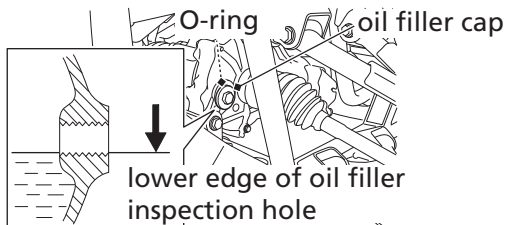

Front Final Gear Oil

Changing Oil

Refer to *Safety Precautions* on page 83.

Change the oil with the front final gear at normal operating temperature to assure complete and rapid draining.

1. Park the Honda SXS on a firm, level surface.
2. Place an oil drain pan under the oil drain plug.
3. Remove the oil filler cap and the drain plug.
4. After the oil has completely drained (3 – 5 minutes), reinstall the drain plug with a new sealing washer and tighten it to the specified torque:
9 lbf·ft (12 N·m, 1.2 kgf·m)
5. Fill the front final gear with the recommended oil.
17.2 US oz (510 cm³)
6. Make sure the oil level is at the lower edge of the oil filler inspection hole.
7. Apply a thin coat of grease to a new O-ring, and insert it into the oil filler cap groove.
8. Install and tighten oil filler cap to the specified torque:
9 lbf·ft (12 N·m, 1.2 kgf·m)
9. Pour the drained oil into a suitable container and dispose of it in an approved manner (page 180).

NOTICE

Improper disposal of drained fluids is harmful to the environment.

LEFT FRONT

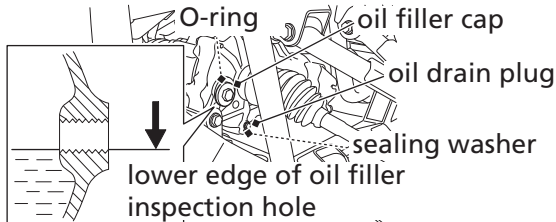

Rear Final Gear Oil

Oil Recommendation

| | |
|--------------------|---|
| API classification | GL-4 or GL-5 except oils labeled as energy conserving on the circular API service label |
| type | hypoid gear oil |
| viscosity (weight) | SAE 80W-90 |
| suggested oil | Honda shaft drive oil or equivalent |

Checking Oil

Refer to *Safety Precautions* on page 83.

Check the rear final gear oil level every 1,800 miles (3,000 km) or 300 hours of operating your Honda SXS, and add if needed.

1. Park your Honda SXS on a firm, level surface.
2. Remove the oil filler cap.
3. Make sure the oil level is at the lower edge of the oil filler inspection hole.
4. Apply a thin coat of grease to a new O-ring, and insert it into the oil filler cap groove.
5. Install and tighten oil filler cap to the specified torque:
9 lbf·ft (12 N·m, 1.2 kgf·m)

RIGHT REAR

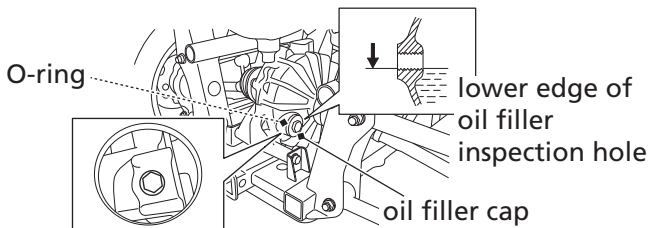

Rear Final Gear Oil

Changing Oil

Refer to *Safety Precautions* on page 83.

Change the oil with the rear final gear at normal operating temperature to assure complete and rapid draining.

1. Park the Honda SXS on a firm, level surface.
2. Place an oil drain pan under the oil drain plug.
3. Remove the oil filler cap and the drain plug.
4. After the oil has completely drained (3 – 5 minutes), reinstall the drain plug with a new sealing washer and tighten it to the specified torque:
9 lbf·ft (12 N·m, 1.2 kgf·m)
5. Fill the rear final gear with the recommended oil.
5.1 US oz (150 cm³)
6. Make sure the oil level is at the lower edge of the oil filler inspection hole.
7. Apply a thin coat of grease to a new O-ring, and insert it into the oil filler cap groove.
8. Install and tighten oil filler cap to the specified torque:
9 lbf·ft (12 N·m, 1.2 kgf·m)
9. Pour the drained oil into a suitable container and dispose of it in an approved manner (page 180).

NOTICE

Improper disposal of drained fluids is harmful to the environment.

RIGHT REAR

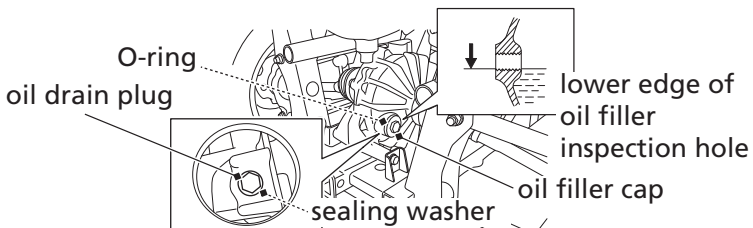

Coolant

Your Honda SXS's liquid cooling system dissipates engine heat through the coolant jacket that surrounds the cylinder and cylinder head.

Maintaining the coolant will allow the cooling system to work properly and prevent freezing, overheating, and corrosion.

Coolant Recommendation

Use Pro Honda HP Coolant or an equivalent high-quality ethylene glycol antifreeze containing corrosion protection inhibitors specifically recommended for use in aluminum engines. Check the antifreeze container label.

Use only distilled water as a part of the coolant solution. Water that is high in mineral content or salt may be harmful to the aluminum engine.

NOTICE

Using coolant with silicate inhibitors may cause premature wear of water pump seals or blockage of radiator passages. Using tap water may cause engine damage.

The factory provides a 50/50 solution of antifreeze and distilled water in this Honda SXS. This coolant solution is recommended for most operating temperatures and provides good corrosion protection.

Decreasing the concentration of antifreeze to less than 40% will not provide proper corrosion protection.

Coolant

Increasing the concentration of antifreeze is not recommended because it decreases cooling system performance. Higher concentrations of antifreeze (up to 60%) should only be used to provide additional protection against freezing. Check the cooling system frequently during freezing weather.

Checking & Adding Coolant

Refer to *Safety Precautions* on page 83.

Check the engine coolant level every day before operating your Honda SXS and add, if needed.

1. Make sure the vehicle is parked on a firm, level surface.
2. Remove the front hood (page 97).
3. With the engine at normal operating temperature, check the coolant level in the reserve tank. It should be between the MAX and MIN level marks.

If the reserve tank is empty, or if coolant loss is excessive, check for leaks and see your dealer for repair.

(cont'd)

Coolant

4. Remove the reserve tank cap.

Always add coolant to the reserve tank. Do not attempt to add coolant by removing the radiator cap.

UNDER FRONT HOOD

RIGHT FRONT

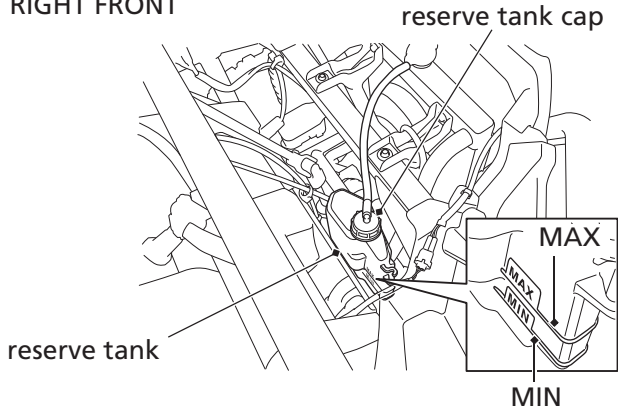

5. Add coolant to the reserve tank as required to bring the coolant level to the MAX level mark.
6. After adding coolant, install the reserve tank cap and install the front hood.

Coolant Replacement

Refer to *Safety Precautions* on page 83.

Coolant should be replaced by your dealer, unless you have the proper tools and service data, and are mechanically qualified. Refer to the official Honda Service Manual.

WARNING

Removing the radiator cap while the engine is hot can cause the coolant to spray out, seriously scalding you.

Always let the engine and radiator cool down before removing the radiator cap.

To properly dispose of drained coolant, refer to *You & the Environment*, page 180.

NOTICE

Improper disposal of drained fluids is harmful to the environment.

Coolant

Radiator Core

Refer to *Safety Precautions* on page 83.

Check the air passages for clogging or damage. Remove insects, mud, or any obstruction with low water pressure. Have the radiator checked by your dealer if more than 20% of the radiator surface air flow is restricted.

Clean the radiator core after driving your Honda SXS in mud.

To clean the radiator core:

1. Remove the front hood (page 97).
2. Wash the radiator core with low water pressure.

NOTICE

Do not apply high pressure water directly to the radiator core. High pressure water can damage the radiator core fins.

Air Cleaner

Refer to *Safety Precautions* on page 83.

Proper air cleaner maintenance is very important for off-road vehicles.

A dirty or dry, water-soaked, worn-out, or defective air cleaner will allow dirt, dust, mud, and other impurities to pass into the engine.

Service the air cleaner more frequently if you drive in unusually wet or dusty areas. Your dealer can help you determine the correct service interval for your driving conditions.

Your Honda SXS's air cleaner has very specific performance requirements. Use a new Honda Genuine air cleaner specified for your model or an air cleaner of equal quality.

NOTICE

Using the wrong air cleaner may result in premature engine wear.

Proper air cleaner maintenance can prevent premature engine wear or damage, expensive repairs, low engine power, poor gas mileage, and spark plug fouling.

NOTICE

Improper or lack of proper air cleaner maintenance can cause poor performance and premature engine wear.

Air Cleaner

Cleaning

1. Remove the seat back (page 99) and center rear panel (page 100).
2. Unlatch the retainer clips.
3. Remove the air cleaner housing cover.

UNDER CARGO CARRIER

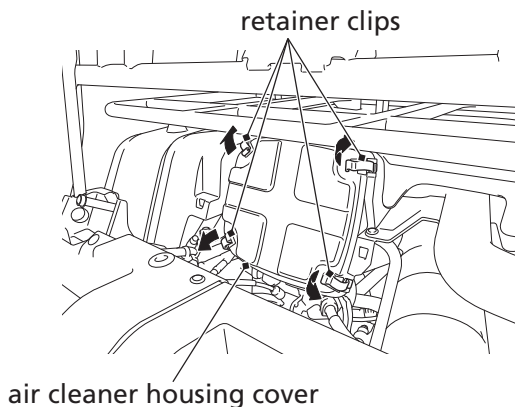

Air Cleaner

4. Remove the air cleaner holder.
5. Loosen the screw and remove the air cleaner assembly from the air cleaner housing.
6. Unscrew the clamp.
7. Remove the air cleaner from the air cleaner body.
8. Gently wash the air cleaner in clean, non-flammable (high flash point) solvent such as kerosene. Do not use gasoline. After cleaning, gently squeeze out the remaining solvent. Avoid twisting or wringing the air cleaner. This can tear the foam.
9. Inspect for tears or cracks in the foam or seams of the air cleaner. Replace the air cleaner if it is damaged.

UNDER CARGO CARRIER

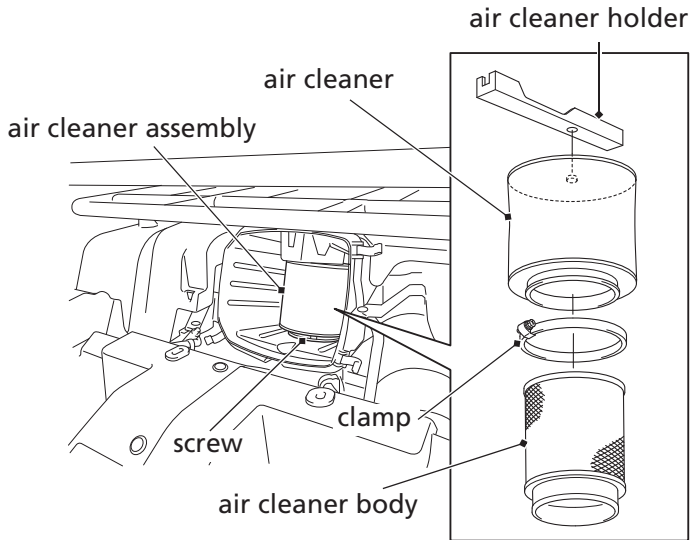

(cont'd)

Air Cleaner

10. Allow the air cleaner to dry thoroughly before applying oil. A wet air cleaner will not fully absorb the oil.
11. Pour clean Pro Honda Foam Filter Oil or an equivalent over the entire surface of the air cleaner. Use both hands to evenly spread the oil into the air cleaner. Gently squeeze out any excess oil. (To keep your hands dry, place the air cleaner in a clean plastic bag before spreading the oil into the air cleaner.)
12. Install the air cleaner on the air cleaner body.
13. Install the clamp.
14. Insert the air cleaner assembly into the air cleaner housing.
15. Fasten the screw.
16. Install the air cleaner holder.
17. Reassemble in the reverse order of removal.

Air Cleaner

Air Cleaner Housing Drain Tube

The air cleaner housing drain tube should be serviced in accordance with the Maintenance Schedule. (Driving through water may require more frequent inspection.) If deposits can be seen in the drain tube, the tube must be cleaned before starting the vehicle.

1. Remove the air cleaner housing drain tube plug by removing the clip.
2. Drain the deposits.
3. Reinstall the air cleaner housing drain tube plug, securing it with the clip.

RIGHT REAR

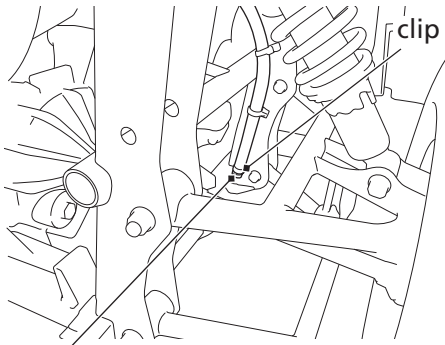

air cleaner housing drain tube plug

Lubrication

To keep moving parts functioning properly, coat them with a multipurpose grease (without Teflon or molybdenum additives, such as CRC 6-56 or equivalent).

Provide lubrication when moving parts do not work smoothly. Also lubricate according to the maintenance schedule (page 88).

Consult your dealer for more information about lubrication procedures.

Apply grease to each pivot to prevent corrosion. Check for smooth movement after lubrication. If the movement is not smooth after applying grease, see your dealer.

Lubrication Points

Lubricate the brake pedal pivot and accelerator pedal pivot as shown in the following illustration.

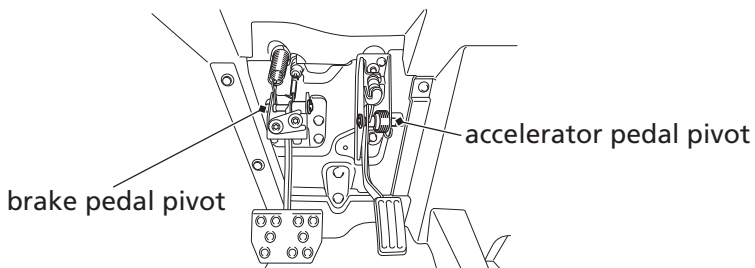

Lubrication

Lubricate the parking brake pivot as shown in the following illustration.

Remove the dust cover.

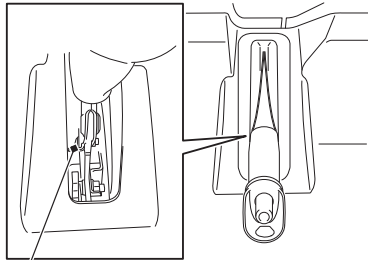

parking brake pivot

Lubricate the drive mode select lever pivot as shown in the following illustration.

Remove the front hood (page 97).

UNDER FRONT HOOD

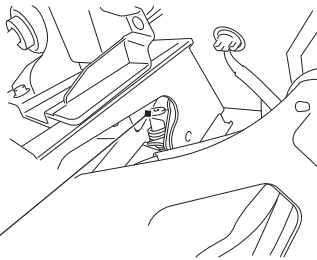

drive mode select lever pivot

Lubrication

Lubricate the door latch spring as shown in the following illustration. Open the door (page 37).

The left and right door latch springs can be lubricated in the same manner.

LEFT SIDE

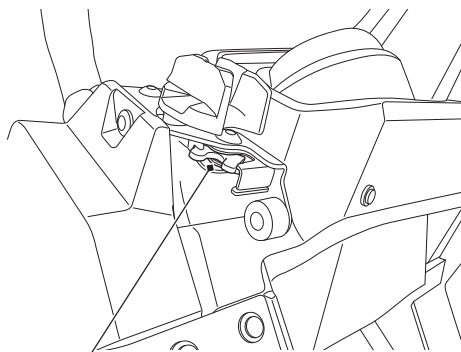

door latch spring

Accelerator Pedal

Accelerator Pedal Inspection

Refer to *Safety Precautions* on page 83.

If the accelerator pedal has excessive play due to cable stretch or incorrect adjustment, it will cause a delay in throttle response, especially at low engine speed. Also, the accelerator may not open fully.

If the accelerator pedal has no play, the accelerator may be hard to control, and the idle speed may be erratic.

Check the accelerator pedal play periodically in accordance with the Periodic Maintenance Chart, and adjust the play if necessary.

Refer to the maintenance schedule on page 88.

Inspection

Check freeplay of the accelerator pedal.

Freeplay:

$5/16 - 1/2$ in (8 – 13 mm)

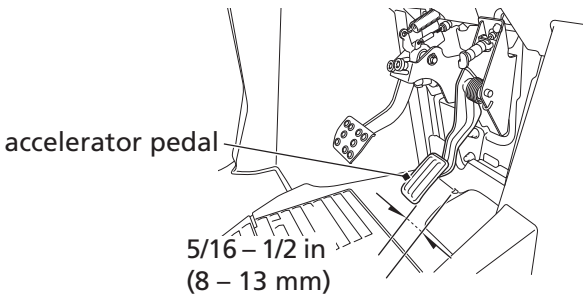

Accelerator Pedal

Adjustment

1. Remove the front hood (page 97).
2. Slide the sleeve back to expose the throttle cable adjuster.
3. Loosen the lock nut.
4. Turn the adjuster to obtain the correct freeplay.
5. Tighten the lock nut and reinstall the sleeve.
6. After adjustment, check for smooth operation of the accelerator pedal.
7. Install the remaining parts in the reverse order of removal.

UNDER FRONT HOOD

LEFT FRONT

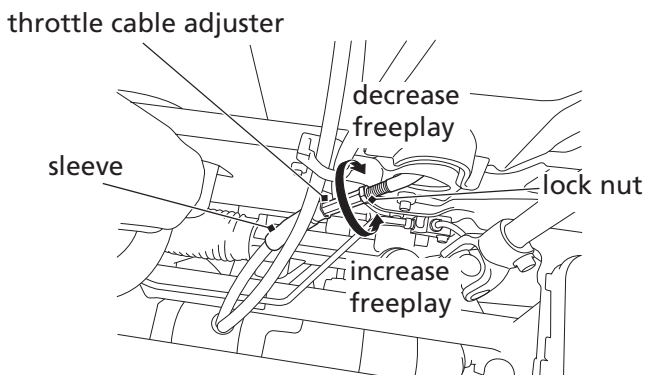

Reverse Inhibitor System

Reverse Lever Inspection

Refer to *Safety Precautions* on page 83.

Check that the reverse lever moves smoothly and allows for proper reverse gear selection, and adjust the play if necessary. Refer to maintenance schedule on page 87.

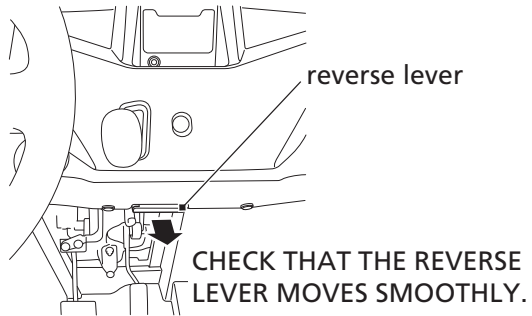

Inspection

Check freeplay of the reverse lever.

Freeplay:

1/4 – 1/2 in (6.0 – 12.0 mm)

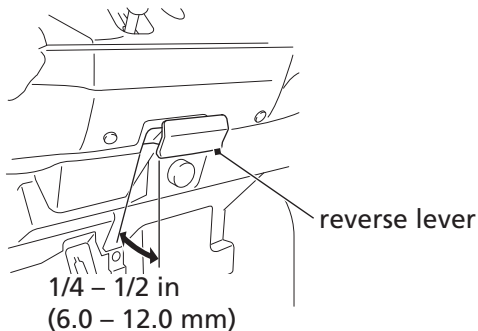

Reverse Inhibitor System

Adjustment

1. To adjust, remove the front hood (page 97), loosen the lock nut, and turn the adjusting nut.
After adjustment, tighten the lock nut securely and check for smooth operation of the reverse lever.
2. Install the remaining parts in the reverse order of removal.

UNDER FRONT HOOD

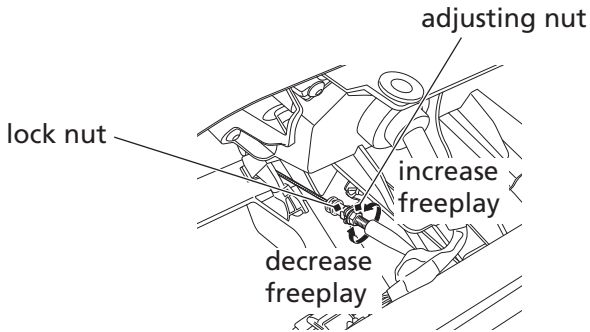

Spark Plug

Spark Plug Recommendation

| | |
|---------------------|--|
| standard spark plug | BKR5E-11 (NGK) or K16PR-U11 (DENSO) |
|---------------------|--|

Use only the recommended type of spark plug in the recommended heat range.

NOTICE

Using spark plugs with an improper heat range can cause engine damage.

Spark Plug Inspection & Replacement

Refer to *Safety Precautions* on page 83.

1. Remove the seat back (page 99) and center rear panel (page 100).
2. Clean any dirt from around the spark plug base.
3. Disconnect the spark plug cap. Take care to avoid damaging the spark plug wire when disconnecting the cap.
4. Using a spark plug wrench provided in the tool kit, remove the spark plug.
5. Inspect the electrodes and center porcelain for deposits, corrosion, or carbon fouling. If the corrosion or deposits are heavy, replace the plug. Clean a carbon or wet-fouled plug with a plug cleaner, if available, or a wire brush. Inspect the spark plug electrodes for wear. The center electrode should have a flat tip and sharp edges, and the side electrode should not be eroded. If the electrodes and insulator tip appear unusually fouled or burned, we suggest that you contact your dealer.

(cont'd)

Spark Plug

6. Discard the spark plug if there is apparent wear or if the insulator is cracked or chipped.
7. Using a wire-type feeler gauge, check the spark plug gap. If adjustment is necessary, bend the side electrode carefully.
The gap should be:
0.039 – 0.043 in (1.00 – 1.10 mm)

UNDER SEAT BACK CENTER

spark plug cap

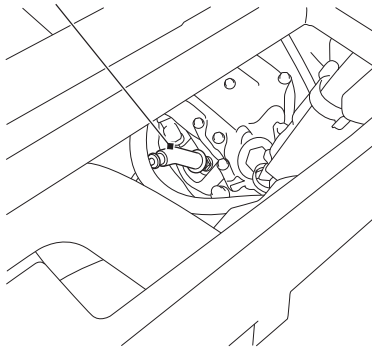

spark plug gap

0.039 – 0.043 in
(1.00 – 1.10 mm)

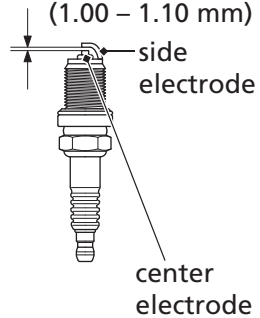

Spark Plug

8. With the plug washer attached, thread the spark plug in by hand to prevent cross-threading.
9. Tighten the spark plug:
 - If the old plug is good:
 - 1/8 turn after it seats.
 - If installing a new plug, tighten it twice to prevent loosening:
 - a) First, tighten the plug:
 - NGK: 3/4 turn after it seats.
 - DENSO: 1/2 turn after it seats.
 - b) Then loosen the plug.
 - c) Next, tighten the plug again:
 - 1/8 turn after it seats.

NOTICE

An improperly tightened spark plug can damage the engine. If a plug is too loose, a piston may be damaged. If a plug is too tight, the threads may be damaged.

10. Connect the spark plug cap. Take care to avoid pinching any cables or wires.
11. Install the center rear panel and seat back.

Spark Arrester

Refer to *Safety Precautions* on page 83.

The spark arrester must be serviced every 600 miles (1,000 km) or 100 operating hours to maintain its efficiency.

(USA & Canada only)

Regular servicing prevents carbon build up (which can diminish engine performance) and also complies with USDA regulations for regular maintenance to assure proper function. The spark arrester prevents random sparks from the combustion process in your engine from reaching the environment.

The use of safety glasses is recommended for this procedure.

Because of the possible fire hazard, check that there are no combustible materials in the area before purging the spark arrester.

1. Select a well-ventilated area free of combustible materials and make sure the exhaust pipe is cool.
2. Remove the bolt.
3. Start the engine and rev it up approximately twenty times while momentarily creating exhaust system back pressure by blocking the end of the muffler with a shop towel.
4. Stop the engine and allow the exhaust pipe to cool.
5. Reinstall the bolt securely.

REAR

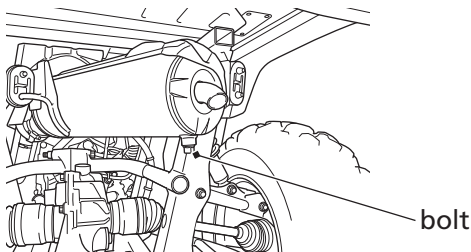

Exhaust System

Exhaust System Inspection

Stop the engine and check for any sign of exhaust gas leakage. Listen for exhaust leaks near the muffler, which is located by the left rear wheel well.

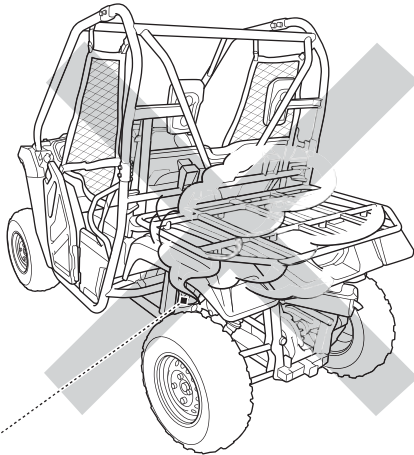

check for exhaust leakage

Suspension

Your front and rear suspension systems use springs and hydraulic damping devices that suspend your weight and most of the weight of your Honda SXS.

The oil damper systems hydraulically control the natural compression and rebound of the suspension springs so that traction and comfort are maintained as the wheels ride over rough terrain.

The spring pre-loads for your front and rear suspension systems adjust the amount of force required to begin compression of the spring.

You may adjust the spring pre-load of both suspension systems.

Consider adjusting your suspensions pre-load whenever you change your normal load, by adding cargo or accessories, or when driving conditions change.

The way you drive your Honda SXS and the type of ride you want to experience can also influence your suspension needs.

Lower spring pre-load provides a softer ride and is usually preferred for light loads and smooth terrain. Higher spring pre-load provides a firmer ride and is recommended for heavy loads and rough terrain.

Suspension

Front Suspension Adjustment

Using a pin spanner, which is available from your dealer, the front suspension can be adjusted for driver and passenger weight, and riding conditions by changing the spring pre-load.

Do not attempt to disassemble, service, or dispose of the damper; see your dealer. The instructions found in this owner's manual are limited to adjustments of the shock assembly only.

Front Suspension Spring Pre-Load

Refer to *Safety Precautions* on page 83.

front

spring pre-load adjuster

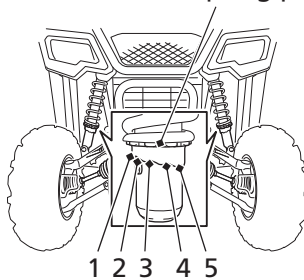

The spring pre-load adjuster has 5 positions for different load or riding conditions. Before adjusting the spring pre-load, jack up your Honda SXS (page 102) to avoid damaging the adjusters.

Use the pin spanner to adjust the shock spring pre-load.

Pin spanner part number: 07702-0020001

Available through your dealer.

Suspension

Position 1: for a light load and smooth terrain.

Position 2: standard position.

Positions 3 to 5: for when the SXS is more heavily loaded. (Also increase spring pre-load for stiffer suspension.)

Make sure that both shock absorbers are adjusted to the same position.

Always adjust the shock absorber position in sequence (1-2-3-4-5 or 5-4-3-2-1). Attempting to adjust directly from 1 to 5 or 5 to 1 may damage the shock absorber.

Rear Suspension Adjustment

Using a pin spanner, which is available from your dealer, the rear suspension can be adjusted for carrying heavier cargo.

Do not attempt to disassemble, service, or dispose of the damper; see your dealer. The instructions found in this owner's manual are limited to adjustments of the shock assembly only.

Suspension

Rear Suspension Spring Pre-Load

Refer to *Safety Precautions* on page 83.

REAR

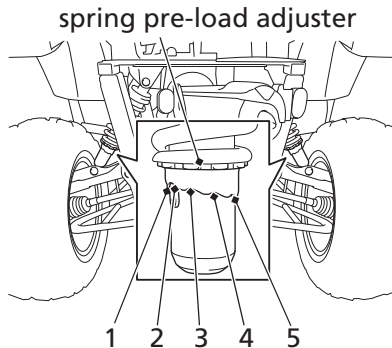

The spring pre-load adjuster has 5 positions for different load or riding conditions. Before adjusting the spring pre-load, jack up your Honda SXS (page 102) to avoid damaging the adjusters.

Use the pin spanner to adjust the shock spring pre-load.

Pin spanner part number: 07702-0020001

Available through your dealer.

Position 1: for a light load and smooth terrain.

Position 2: standard position.

Positions 3 to 5: for when the SXS is more heavily loaded. (Also increase spring pre-load for stiffer suspension.)

Make sure that both shock absorbers are adjusted to the same position.

Always adjust the shock absorber position in sequence (1-2-3-4-5 or 5-4-3-2-1). Attempting to adjust directly from 1 to 5 or 5 to 1 may damage the shock absorber.

Brakes

The hydraulic disc braking system on your Honda SXS dissipates the heat generated by the friction of the brake pads on the disc as the wheels are slowed.

As the front and rear brake pads wear, the brake fluid level will drop. A leak in the system will also cause the level to drop.

There are no adjustments to perform, but fluid level and pad wear must be inspected periodically. The system must also be inspected frequently to ensure there are no fluid leaks.

If the brake pedal freeplay seems abnormal or the pedal feels spongy, see your dealer to have the air bled from the system.

Brake Operation Check

Refer to *Safety Precautions* on page 83.

Push down on the brake pedal to check that the controls operate normally.

Check for damage to the brake pads and disc plate.

Brake Fluid Recommendation

| | |
|-------------|-------------------------|
| brake fluid | Honda DOT 4 Brake Fluid |
|-------------|-------------------------|

The recommended brake fluid is Honda DOT 4 Brake Fluid, or any brake fluid of equal quality and performance. Use fresh brake fluid from a sealed container. Be sure to read the label before opening the sealed container. An opened container may be contaminated or may have absorbed moisture from the air.

Fluid Level Inspection

Refer to *Safety Precautions* on page 83.

Brake Fluid Level

If your inspection indicates a low fluid level, have your dealer inspect the brake system for possible leaks or worn brake pads.

The brake fluid level will drop as the brake pads wear.

Do not add or replace brake fluid, except in an emergency. If you do add fluid, have your dealer check the system as soon as possible.

NOTICE

Brake fluid can damage plastic and painted surfaces. Handle with care.

Check the fluid level on level ground.

1. Slide the brake fluid reservoir tank cap cover up a little to reveal the MAX level mark. Do not remove the brake fluid reservoir tank cap cover.

LEFT FRONT

brake fluid reservoir tank cap cover

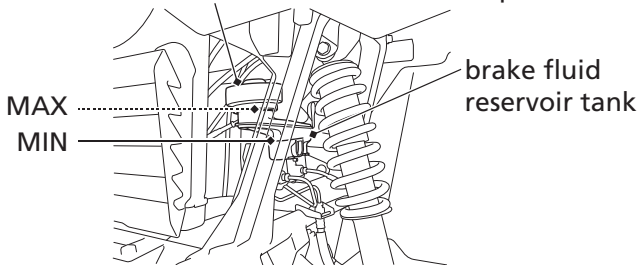

It should be between the MIN and MAX level marks. If the level is at or below the MIN level mark, check the brake pads for wear (page 149).

(cont'd)

Brakes

2. Return the brake fluid reservoir tank cap cover to its normal position.

Worn brake pads should be replaced. If the pads are not worn, have your brake system inspected for leaks.

Wipe up spills immediately. Avoid contact with skin or eyes.

If brake fluid comes in contact with your eyes, wash them out with clean water and immediately call a doctor.

If brake fluid comes in contact with your skin, wash with clean water and, if necessary, call a doctor.

Other Inspections

- Make sure there are no fluid leaks.
- Check for deterioration or cracks in the hoses and fittings. If the hoses are worn or cracked, have them replaced by your dealer.

Brake Pad Wear

Refer to *Safety Precautions* on page 83.

Brake pad wear will depend upon the severity of usage and driving conditions. The pads will wear faster in wet or muddy conditions. Inspect the pads during all regular service intervals to determine the pad wear.

Note that the pads are designed to make a metallic noise during braking when they reach the wear limit.

Front:

If you hear a continuous metallic friction sound when applying the brakes, the brake pads need to be replaced. Have the vehicle checked by a dealer.

Rear:

Check the wear indicator. If the wear indicator aligns with the reference mark, replace both pads as a set, see your dealer for this service.

RIGHT REAR

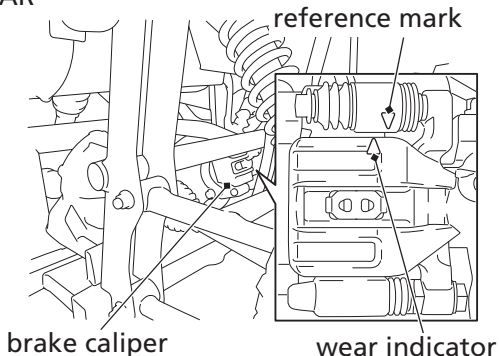

Brakes

Brake Pedal Inspection

Refer to *Safety Precautions* on page 83.

Check that the brake pedal moves smoothly and does not feel abnormally spongy. Refer to the maintenance schedule on page 88.

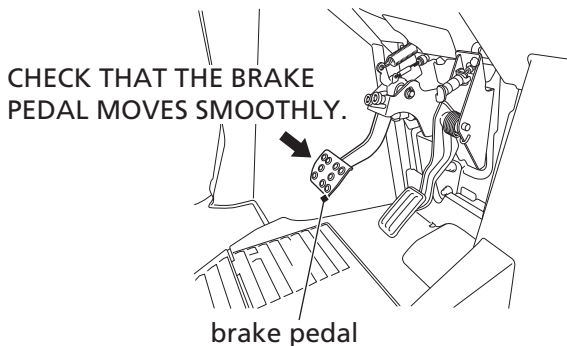

Parking Brake Lever Freeplay

Refer to *Safety Precautions* on page 83.

Inspection

Measure the freeplay of the parking brake.

Freeplay is measured from the lever fully disengaged (at stopper) to when lever is pulled up and resistance is felt in lever.

Parking brake lever freeplay is:

1 9/16 – 1 15/16 in (40 – 50 mm)

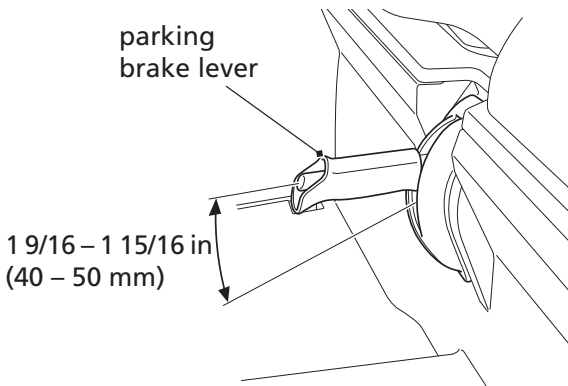

If adjustment is necessary, have the parking brake adjusted by your dealer.

Brakes

Brake Light Switch Adjustment

Refer to *Safety Precautions* on page 83.

Periodically check the operation of the brake light switch. It is located under the front hood (page 97), just above -- and slightly behind -- the brake fluid reservoir.

The brake light should turn on just before the brake works.

Adjustment is done by holding the switch body and turning the adjusting nut. Turn the nut in direction (A) if the switch operates too late, and in direction (B) if the switch operates too soon.

UNDER FRONT HOOD

LEFT SIDE

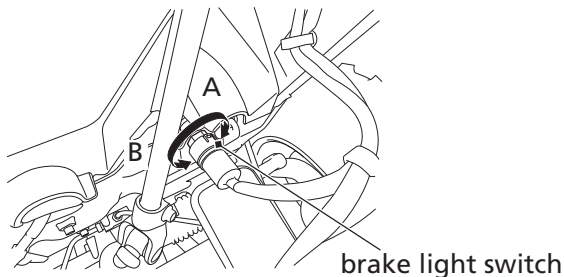

Tires

To safely operate your Honda SXS, your tires must be the proper type and size, in good condition with adequate tread, and correctly inflated.

WARNING

Using tires that are excessively worn or improperly inflated can cause a crash in which you can be seriously hurt or killed.

Follow all instructions in this owner's manual regarding tire inflation and maintenance.

The following pages give detailed information on how and when to check your air pressure, how to inspect your tires for wear and damage, and our recommendations for tire repair and replacement.

Tires

Air Pressure

Refer to *Safety Precautions* on page 83.

Properly inflated tires provide the best combination of handling, tread life, and driving comfort. Generally, underinflated tires wear unevenly, adversely affect handling, and are more likely to fail from being overheated. Overinflated tires make your Honda SXS drive harshly, are more prone to damage from surface hazards, and wear unevenly.

Make sure the valve stem caps are secure. If necessary, install new caps.

Tires

Always check air pressure when your tires are “cold.” If you check air pressure when your tires are “warm” — even if your Honda SXS has only been driven for a few miles — the readings will be higher. If you let air out of warm tires to match the recommended cold tire pressures, the tires will be underinflated. Be sure to check tire pressure at the driving site, since changes in altitude and temperature can affect air pressure.

The recommended “cold” tire pressures are:

| | |
|-------|-----------------|
| FRONT | 10 psi (70 kPa) |
| REAR | 10 psi (70 kPa) |

Tires

A manually operated tire pump should be used rather than the high pressure system found in service stations. This will minimize the possibility of tire damage from overinflation. If you use a high pressure system at a service station, add air in small amounts and check the pressure increase frequently to prevent possible tire damage from overinflation.

WARNING

Operating this Honda SXS with improper tires, or with uneven tire pressure may cause loss of control, and you could be seriously injured or killed.

- Always use the size and type tires specified in this owner's manual for this vehicle.
- Always maintain proper tire pressure as described in this owner's manual.

Inspection

Refer to *Safety Precautions* on page 83.

Whenever you check the tire pressures, you should also look for:

- Bumps or bulges in the side of the tire or the tread. Replace any tire that has a bump or bulge.
- Cuts, slits, or cracks in the tires. Replace the tire if you can see fabric or cord.
- Nails or other foreign objects embedded in the side of the tire or tread.
- Excessive tread wear.

Tires

Also, if you hit a hard object or obstacle while driving, stop as soon as you safely can and carefully inspect the tires for damage.

Tread Wear

FRONT

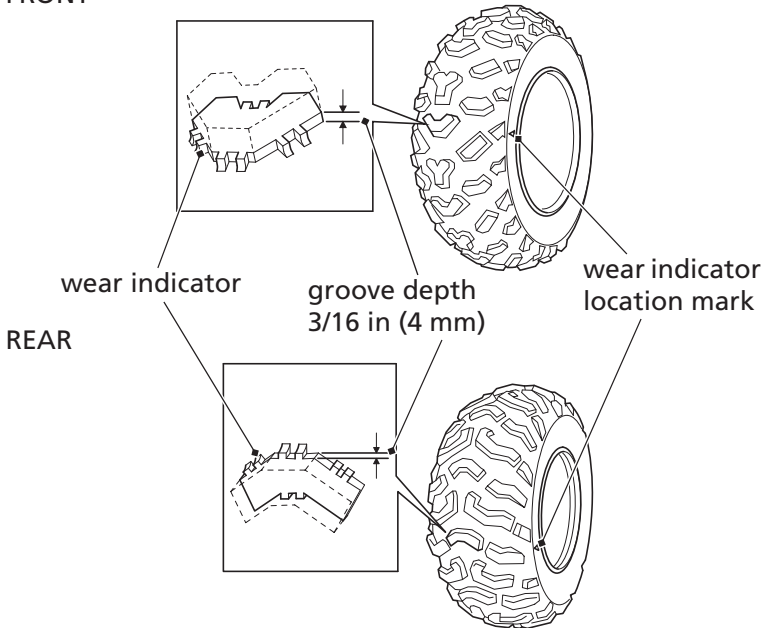

To check the condition of a tire tread, measure the groove depth in the center of the tire, or check the wear indicator.

For best performance, you should replace a tire before the tread depth at the center reaches the following limits:

| | |
|-------|----------------|
| front | 3/16 in (4 mm) |
| rear | 3/16 in (4 mm) |

Tires

Tire Repair

Refer to *Safety Precautions* on page 83.

We strongly recommend that you replace, not repair, any tire that is punctured or damaged. As discussed below, a tire that is repaired, either temporarily or permanently, will have lower speed and performance limits than a new or undamaged tire.

A temporary repair can sometimes be made in an emergency situation. However, since a temporary repair may not hold, you must drive very slowly, preferably without any cargo, and have the tire replaced or permanently repaired as soon as possible. (For more information on temporary repairs, see *If You Have a Flat Tire*, page 190.)

A permanent repair, such as an internal plug patch, can be made if a tire has only a small puncture in the tread area. With such a repair, you should drive very slowly for the first 24 hours. However you may not be able to safely carry as much weight. If you choose to have a tire repaired, be sure the repair work is performed by a professional.

If you have a tire professionally repaired at a non-Honda facility, we recommend that you have the work checked by your Honda dealer.

Tire Replacement

Refer to *Safety Precautions* on page 83.

The tires that came on your Honda SXS were designed to match the performance capabilities of the vehicle and provide the best combination of handling, braking, and comfort.

It is best to replace all four tires. However, if that is not possible, you must replace the tires in pairs (front or rear) with tires of the same size and type as the originals. Never replace just one tire.

WARNING

Installing improper tires on your Honda SXS can affect handling and stability. This can cause a crash in which you can be seriously hurt or killed.

Always use the size and type of tires recommended in this owner's manual.

The recommended tires for your Honda SXS are:

| | |
|-------|------------------------------|
| front | 24X8.00-12 NHS MAXXIS M977H |
| rear | 24X10.00-12 NHS MAXXIS M978H |

When you replace a tire, remember:

Have the tire replaced by your Honda dealer, if possible.

If you have a tire professionally replaced at a non-Honda facility, we recommend that you have the work checked by your Honda dealer.

Wheels

Inspection

Check that the wheel nuts are tight and there are no cracks or deformation in the wheel.

**CHECK FOR CRACKS
OR DEFORMATION.**

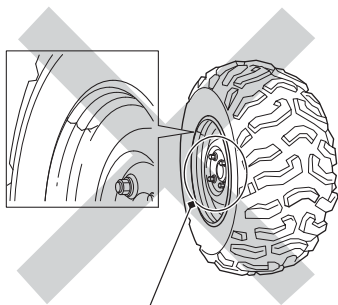

**CHECK THAT THE WHEEL NUTS
ARE TIGHT**

Driveshaft Boots

Refer to *Safety Precautions* on page 83.

Check the boots for tears or traces of splattered grease.
If necessary, have your dealer replace them.

FRONT

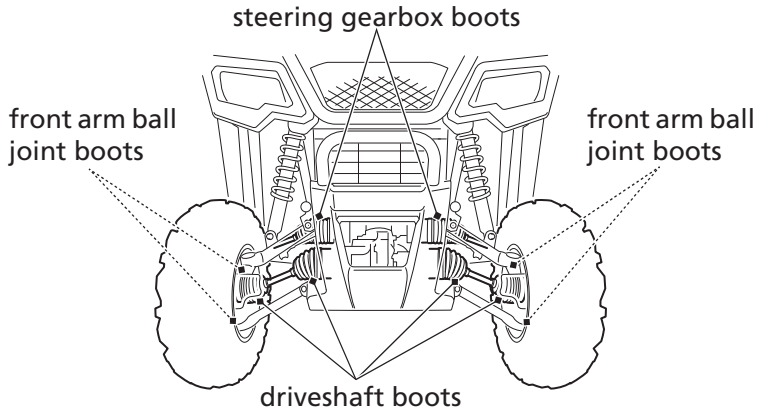

REAR

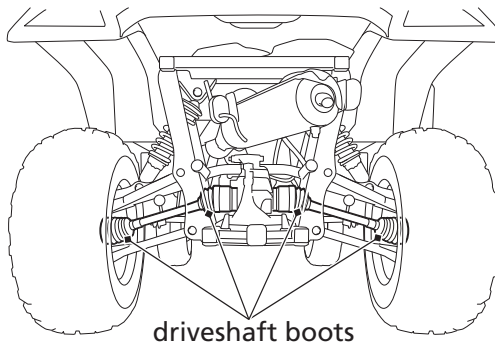

Battery

Your Honda SXS has a maintenance-free type battery. You do not have to check the battery electrolyte level or add distilled water as you would with a conventional-type battery.

NOTICE

Your battery is a maintenance-free type and can be permanently damaged if the cap strip is removed.

Electrical accessories use current from the battery, some even when the ignition is OFF (O). Limited operation of your Honda SXS also allows the battery to discharge. If you have electrical accessories on your Honda SXS, or do not drive frequently, we recommend that you charge the battery frequently (see *Battery Charging*, page 166).

If you do not expect to drive your Honda SXS for at least two weeks, we recommend you remove the battery, or at least disconnect the battery cables (negative cable first).

If you plan to store your Honda SXS, see *Battery Storage*, page 163.

If your battery seems weak and/or is leaking electrolyte (causing slow starting or other electrical problems), see your dealer.

WARNING: Battery posts, terminals and related accessories contain lead and lead compounds. **Wash your hands after handling.**

Battery Storage

Refer to *Safety Precautions* on page 83.

If you plan to store your Honda SXS, we recommend you remove the battery and store it where it can be charged every 30 days to maintain its service life.

If you do not remove the battery, we recommend disconnecting the battery cables (negative cable first).

Check the terminals for corrosion (a white or yellowish powder). To remove it, cover the terminals with a solution of baking soda and water. It will bubble up and turn brown. When this stops, wash it off with plain water. Dry off the battery with a cloth or paper towel.

You will get the best storage results from removing the battery and slow charging it every 30 days (see *Battery Charging*, page 166). Before you remove the battery, be sure to read all the information that follows, as well as the information on the battery label.

WARNING

The battery gives off explosive hydrogen gas during normal operation.

A spark or flame can cause the battery to explode with enough force to kill or seriously hurt you.

Wear protective clothing and a face shield, or have a skilled mechanic do the battery maintenance.

Battery

The battery is located under the right side of rear fender.

Removal

1. Make sure the ignition switch is OFF (O).
2. Remove the bolts and battery cover.
3. Release the ring and remove the rubber band.
4. Disconnect the negative (-) terminal lead from the battery first, then disconnect the positive (+) terminal lead.
5. Remove the battery from the battery box.
6. Charge the battery (see the following section), unless you have been driving regularly.
7. Store your battery in an easy-to-reach location off the floor, in an area protected from freezing temperature and direct sunlight.
8. Clean the battery box after removing the battery for storage. Dry the battery box.
9. Slow charge the battery (see following section) once every 30 days.

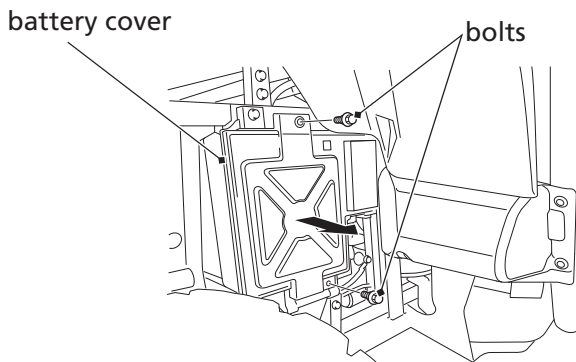

Battery

positive (+) terminal lead

negative (-) terminal lead

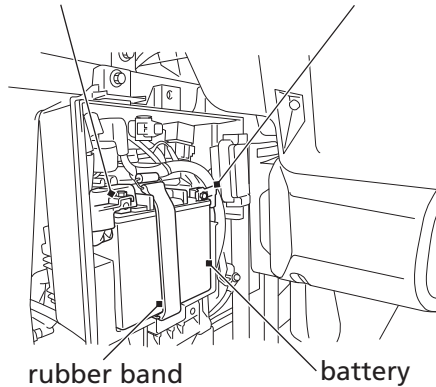

Installation

Reinstall in the reverse order of removal.

Be sure to connect the positive (+) terminal first, then the negative (-) terminal.

Make sure the clock is set to the proper time after the battery is reconnected (page 23).

Battery

Battery Charging

Refer to *Safety Precautions* on page 83.

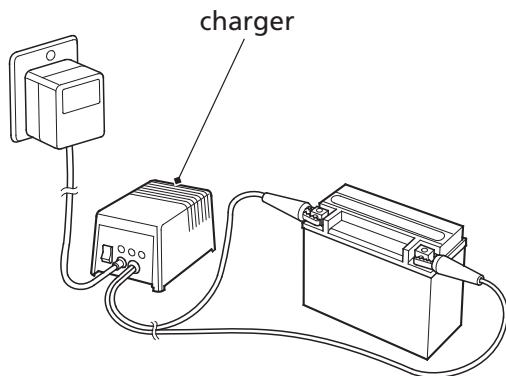

Be sure to read the information that came with your battery charger and follow the instructions on the battery. Improper charging may damage the battery.

We recommend using a charger designed specifically for your Honda, which can be purchased from your dealer. These units can be left connected for long periods without risking damage to the battery. However, do not intentionally leave the charger connected longer than the time period recommended in the charger's instructions.

Avoid using an automotive-type battery charger. An automotive charger can overheat a Honda SXS battery and cause premature damage.

Appearance Care

Frequent cleaning and polishing will keep your Honda looking newer longer.

Frequent cleaning also identifies you as an owner who values his Honda SXS. A clean Honda SXS is also easier to inspect and service.

General Recommendations

Refer to *Safety Precautions* on page 83.

- To clean your Honda SXS, you may use:
 - water
 - Hondabrite
 - a mild, neutral detergent and water
 - a mild spray and wipe cleaner/polisher
 - a mild spray and rinse cleaner/degreaser and water
- Avoid products that contain harsh detergents or chemical solvents that could damage the metal, paint, plastic, and camouflage coating on your ATV (Honda SXS).
- If your Honda SXS is still warm from recent operation, give the engine and exhaust system time to cool off.
- Park in a shady area. Washing your Honda SXS in bright sunlight may cause the finish to fade because water droplets intensify the sun's brightness.
- Spotting is also more likely because surface water can dry before you have time to wipe it off.
- Clean your Honda SXS regularly to protect surface finishes.
- We recommend the use of a garden hose to wash your Honda SXS. High pressure washers (like those at coin-operated car washers) can damage certain parts of your Honda SXS.

NOTICE

High pressure water (or air) can damage certain parts of your Honda SXS.

Appearance Care

- After cleaning, inspect for damage, wear, and leaks (fuel, oil, coolant and brake fluid).

Washing Your Honda SXS with a Mild Detergent

Refer to *Safety Precautions* on page 83.

1. Rinse your Honda SXS thoroughly with cool water to remove loose dirt.
2. Fill a bucket with cool water. Mix in a mild, neutral detergent, such as dish washing liquid or a product made especially for washing motorcycles or automobiles.
3. Wash your Honda SXS with a sponge or soft towel. As you wash, check for heavy grime. If necessary, use a mild cleaner/degreaser to remove the grime.
4. After washing, rinse your Honda SXS thoroughly with plenty of clean water to remove any residue. Detergent residue can corrode alloy parts.
5. Dry your Honda SXS with a chamois or a soft towel. Leaving water on the surface to air dry can cause dulling and water spots. As you dry, inspect for chips and scratches.
6. Start the engine and let it idle for several minutes. The engine heat will help dry moist areas.
7. As a precaution, drive your Honda SXS at a slow speed and apply the brakes several times. This will help dry the brakes and restore normal braking performance.
If the inside of the headlight lens appears clouded immediately after washing, it should clear after a few minutes of headlights operation.

Appearance Care

Spray Cleaning Your Honda SXS

Refer to *Safety Precautions* on page 83.

Avoid using spray cleaner products on the tires or suspension components.

Suggestions for using spray cleaners:

| Honda SXS condition | Recommended Cleaning |
|-------------------------------------|--|
| Dust and fingerprint smudges. | Apply a spray cleaner/polish and wipe paint, chrome, glass, and clear plastic. |
| Light road grime. | Spray any difficult-to-reach or very dirty areas with a spray cleaner/degreaser. Rinse and dry. Apply a spray cleaner/polish and wipe with a non-abrasive cloth. |
| Heavy grime. Oil leaks. Brake dust. | Use a spray cleaner/degreaser. If necessary, rub with a sponge. Rinse and dry. Apply a spray cleaner/polish and wipe with a non-abrasive cloth. |
| Dull, corroded chrome or aluminum. | Apply a high quality chrome/aluminum polish and wipe with a non-abrasive cloth. |

Appearance Care

Finishing Touches

Refer to *Safety Precautions* on page 83.

After washing your Honda SXS, consider using a commercially available spray cleaner/polish or quality liquid or paste wax to finish the job. Use only a non-abrasive polish or wax made specifically for motorcycles or automobiles. Apply the polish or wax according to the instructions on the container.

(USA & Canada only)

If a surface on your Honda SXS is chipped or scratched, your dealer has touch-up paint to match your Honda SXS's color. Be sure to use your Honda SXS's color code (page 207) when you buy touch-up paint.

If the frame has a chip that exposes the metal, first apply primer (to prevent corrosion) and then apply the touch-up paint. Several thin layers of touch-up paint are better than one thick coat.

Exhaust Pipe and Muffler Maintenance

Refer to *Safety Precautions* on page 83.

The exhaust pipe and muffler are stainless steel but may become stained by mud or dust. Make sure no flammable materials or debris are sticking to the exhaust system. If any flammable materials or debris is found, remove it.

To remove mud or dust, use a wet sponge and a liquid kitchen abrasive, then rinse well with clean water. Dry with chamois or a soft towel.

If necessary, remove heat stains by using a commercially available fine texture compound. Then rinse by the same manner as removing mud or dust.

Here's some helpful advice on how to prepare for an off-road adventure, how to transport and store your Honda, and how to be an environmentally responsible Honda SXS owner.

| | |
|---|-----|
| Preparing for a Drive..... | 172 |
| What to Take to the Operating Area..... | 172 |
| What to Take on the Trail | 173 |
| Transporting Your Honda | 174 |
| Storing Your Honda..... | 176 |
| Preparation for Storage..... | 177 |
| Removal from Storage | 179 |
| You & the Environment | 180 |

Preparing for a Drive

A safe and enjoyable drive begins with good planning and preparation. Always drive with at least one other person in case you have trouble, and let someone know where you're going and when you expect to return.

Before driving in an unfamiliar area, find out in advance if you need special permits, get maps so you can study the terrain, and talk to other drivers who know the area. The Forest Service and the Bureau of Land Management (USA only), the Ministry of Natural Resources (Canada only), driver's clubs, and off-road magazines are good sources of information.

What to Take to the Operating Area

Along with your Honda SXS and personal safety gear, you should take along some tools and supplies in case you have a problem. For some of the difficulties you might encounter, see *Taking Care of the Unexpected*, which begins on page 181.

We recommend that you always take water, food, a first aid kit, and your owner's manual. Other items you should consider taking along include:

- a tool kit
- tire repair supplies and tools
- wire, duct tape, and rope
- extra gasoline and a fire extinguisher

Preparing for a Drive

What to Take on the Trail

What you take with you during a ride depends on the kind of terrain, how long you expect to drive, how far you might go from help, and how experienced you or your companions are in making repairs.

If you decide to take some tools, spare parts, or other supplies on the trail, be sure you can carry them safely and know how to use them. Also, be sure to follow the loading guidelines and weight limit (page 57).

Transporting Your Honda

Do not tow your Honda SXS behind a car or other vehicle except on a trailer.

Follow these procedures:

1. Set the parking brake, and the drive mode select lever in 4WD.

Transporting Your Honda

2. Secure the vehicle with tie-down straps in the areas shown.
 - Suitable tie-down straps are available from your dealer.
 - Ordinary rope is not recommended because it can stretch under load.
 - Using tie-down straps in any other areas can damage your Honda SXS.
3. Rock the vehicle back and forth to make sure the tie-down straps are tight and the vehicle is secure.

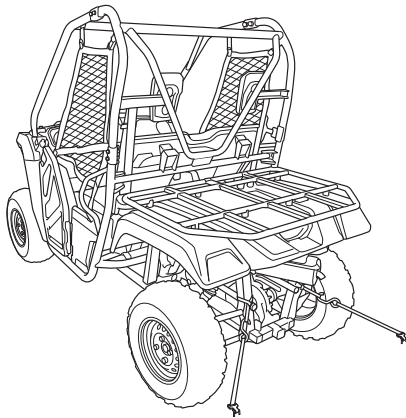
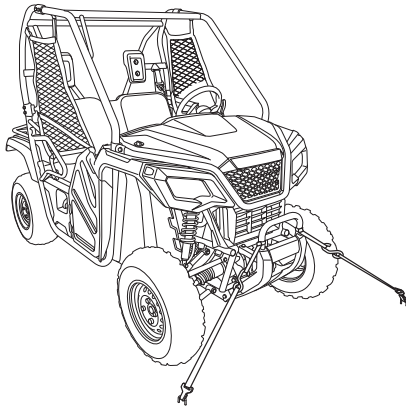

Storing Your Honda

If you won't be driving for an extended period, such as during the winter, thoroughly inspect your Honda SXS and correct any problem before storing it. That way, needed repairs won't be forgotten and it will be easier to get your Honda SXS running again.

We suggest you perform the following procedures to keep your Honda SXS in top condition. These storage procedures will reduce the deterioration that can occur during storage.

Storing Your Honda

Preparation for Storage

Refer to *Safety Precautions* on page 83.

1. Change the engine oil and filter (page 111).
2. Make sure the cooling system is filled with a 50/50% antifreeze solution (page 120).
3. Add Pro Honda Fuel Stabilizer or equivalent to the fuel tank before filling it with fuel. Fill the fuel tank. Make sure the fuel fill cap is properly installed. Run the engine so that the treated fuel will circulate into the fuel injector.
4. To prevent rusting in the cylinder, perform the following:
 - Remove the seat back (page 99) and center rear panel (page 100), and disconnect the spark plug cap from the spark plug.
 - Remove the spark plug.
Do not connect the spark plug to the spark plug cap.
 - Pour a tablespoon (15 – 20 cc) of clean engine oil into the cylinder and cover the spark plug hole with a piece of cloth.
 - Turn the ignition switch to the START (II) position and crank the engine several times to distribute the oil.
 - Reinstall the spark plug, spark plug cap, center rear panel and seat back.

(cont'd)

Storing Your Honda

5. Remove the battery and charge it fully. Store it in an area protected from freezing temperatures and direct sunlight. Slow charge the battery (page 166) once a month.

WARNING

The battery gives off explosive hydrogen gas during normal operation.

A spark or flame can cause the battery to explode with enough force to kill or seriously hurt you.

Wear protective clothing and a face shield, or have a skilled mechanic do the battery maintenance.

6. Wash and dry your Honda SXS. Wax all painted surfaces.
7. Inflate the tires to their recommended pressures (page 155).
8. Store your Honda SXS in an unheated area, free of dampness, away from sunlight, with a minimum of daily temperature variation.
9. Place your Honda SXS on blocks to lift all tires off the floor.
10. Cover your Honda SXS with a porous material. Avoid using plastic or similar non-breathing, coated materials that restrict air flow and allow heat and moisture to accumulate.

Storing Your Honda

Removal from Storage

Refer to *Safety Precautions* on page 83.

1. Uncover and clean your Honda SXS.
2. If your Honda SXS has been stored for more than four months — change the engine oil (page 111).
3. If your Honda SXS has been stored for more than two months — ask your dealer to drain and replace the fuel.
4. Charge the battery (page 166) as required. Install the battery.
5. Perform a pre-ride inspection (page 54), then test-ride your Honda SXS at low speeds.

You & the Environment

Owning and operating a Honda SXS can be enjoyable, but you must do your part to protect nature. When you show respect for the land, wildlife, and other people, you also help preserve off-road driving.

Following are tips on how you can be an environmentally responsible Honda SXS owner.

- **Tread Lightly.** Stay on existing paths and trails, avoid surfaces that are easily damaged, and drive only in areas approved for off-road vehicles.
- **Keep the Noise Down.** Loud vehicles can be offensive. Drive as quietly as possible, don't remove your spark arrester, and don't modify the muffler or any other part of your air intake and exhaust systems. Such modifications not only increase noise, they also reduce engine performance and may be illegal.
- **Choose Sensible Cleaners.** Use a biodegradable detergent when you wash your Honda SXS. Avoid aerosol spray cleaners that contain chlorofluorocarbons (CFCs) which damage the atmosphere's protective ozone layer. Don't throw cleaning solvents away; see the following guidelines for proper disposal.
- **Recycle Wastes.** It's illegal and thoughtless to put used engine oil in the trash, down a drain, or on the ground. Used oil, gasoline, and cleaning solvents contain poisons that can hurt refuse workers and contaminate our drinking water, lakes, rivers, and oceans. Before changing your oil, make sure you have the proper containers. Put oil and other toxic wastes in separate sealed containers and take them to a recycling center. Call your local or state office of public works or environmental services to find a recycling center in your area, and to get instructions on how to dispose of non-recyclable wastes.

Taking Care of the Unexpected

With all the challenges you can encounter off-road, there's a chance that sometime something may go wrong. This section gives practical advice to help you deal with a wide range of problems. Take time to read this section before you drive. Also review the tips in *Preparing for a Drive* (page 172).

| | |
|---|-----|
| General Guidelines | 182 |
| If Your Engine Quits or Won't Start | 184 |
| If the Shift Paddles Do Not Function | 187 |
| Emergency Gear Selection & Operation | 188 |
| If You Have a Flat Tire..... | 190 |
| If the High Coolant Temperature Indicator Lights..... | 193 |
| If a Fuse Blows..... | 195 |
| If You Crash | 199 |
| If You Lose Your Key | 200 |
| If the Battery Is Low | 201 |
| If a Component Fails..... | 203 |

Taking Care of the Unexpected

General Guidelines

Keeping your Honda SXS well-maintained is the best way to reduce the possibility of having a problem while driving. However, problems can arise even with well-maintained machines.

Remember to take along your owner's manual, the tool kit that came with your Honda SXS, and any other items (such as tire repair supplies and additional tools) that might help you solve a problem on your own.

If something goes wrong during a drive, the first thing to do is stop as soon as you safely can. Do not continue driving if you have a flat tire, or you hear an unusual noise, or your Honda SXS just doesn't feel right. If you continue driving, you could cause more damage and endanger your own safety.

After stopping, take time to assess the situation. Carefully inspect your Honda SXS to identify the problem, then consider your options before you decide what to do.

If a problem is relatively minor and you have the tools, supplies, and skills to make a permanent repair, you may be able to fix it on the trail and continue driving.

When a problem is more serious — or you don't have the tools, supplies, experience, or time to deal with it — you need to choose the safest way to get yourself and your Honda SXS back home.

Taking Care of the Unexpected

Should you ever have a problem while driving, please follow these guidelines:

- Always put personal safety first.
- Take time to assess the situation and your options before deciding what to do.
- If the problem is relatively minor and you have the tools, supplies, and skills to make a temporary repair, be sure to have permanent repairs made as soon as possible.
- Do not continue driving if you are hurt or your Honda SXS is not in safe driving condition.

Additional recommendations for specific problems follow.

If Your Engine Quits or Won't Start

Proper operation and maintenance can prevent starting and engine performance problems. In many cases, the cause of the problem may be a simple operational oversight.

If you have a problem starting the engine — or experience poor engine performance — the following information may help you. If you can't correct the problem, see your dealer.

If your SXS won't start, listen as you turn the ignition key to the START (II) position. If you don't hear the starter motor turning, refer to the *Starter motor doesn't operate* symptom. If you can hear the starter motor working normally, refer to the *Starter motor works, but the engine won't start* symptom.

If Your Engine Quits or Won't Start

| SYMPTOM: Starter motor doesn't operate. | |
|--|--|
| POSSIBLE CAUSE | WHAT TO DO |
| transmission not in neutral | Shift into neutral or press on the brake pedal. |
| blown fuse | Replace with a new fuse of the same rating (page 195). |
| battery lead loose | Tighten the battery lead. |
| low battery | Charge the battery (page 166). If charging doesn't help, see your dealer. |
| faulty starter motor | If all possible causes are negative, the starter motor may be faulty. See your dealer. |

| SYMPTOM: Starter motor works, but the engine won't start. | |
|--|--|
| POSSIBLE CAUSE | WHAT TO DO |
| out of fuel | Fill the fuel tank. |
| flooded engine | See starting the engine step 5 (page 63). |
| loose or unconnected spark plug cap | Install the spark plug cap securely. If the engine still won't start, see your dealer. |
| loose battery cables | Tighten the battery terminal bolts. |
| weak battery | Charge the battery (page 166). If charging doesn't help, see your dealer. |

If Your Engine Quits or Won't Start

| SYMPTOM: Engine starts, but runs poorly. | |
|--|---|
| POSSIBLE CAUSE | WHAT TO DO |
| high coolant temperature | Check the high coolant temperature indicator. Refer to <i>If the High Coolant Temperature Indicator Lights</i> , page 193. |
| runs erratically, misfires | May damage catalytic converter. See your dealer. |
| blubbers (rich fuel mixture) | See your dealer. |
| sooty exhaust (rich fuel mixture) | See your dealer. |
| detonates or pings under load | If applicable, switch to the recommended octane gasoline (page 103) or change your brand of gasoline. If the problem persists, see your dealer. |
| afterfires (backfires) | May damage catalytic converter. See your dealer. |
| pre-ignition (runs on after ignition switched OFF) | May damage catalytic converter. See your dealer. |

| SYMPTOM: Engine starts, but runs poorly or dies when hot. | |
|--|--|
| POSSIBLE CAUSE | WHAT TO DO |
| poor or inadequate fuel flow due to clogged fuel filter | See your dealer. (ensure clean fuel supply) |

If the Shift Paddles Do Not Function

If one or both shift paddles do not function, see the following instructions. If proper function cannot be restored, see your dealer.

1. If the engine is running, stop the SXS.
2. Turn the ignition switch to the "OFF" (O) position.
3. After the engine stops, turn the ignition switch to the "ON" (I) position.
4. Pull the upshift paddle then the downshift paddle and check that they are functioning.
5. If both paddles are functioning, shift into neutral and restart the engine.
If one or both paddles are not functioning, see *Emergency Gear Selection & Operation*, page 188.

When the battery is low:

- See *If the Battery Is Low*, page 201.

Emergency Gear Selection & Operation

If the shift paddles do not operate, use the following procedure to manually select a gear so you may drive the vehicle to a location where it can be loaded and transported to a Dealer.

1. Make sure unit is on level ground.
2. Turn the ignition switch to the "ON" (I) position.
3. Remove the seat bottom (page 98).
4. Gear change tool is located under the seat bottom on left side.
5. Check the neutral indicator,
If the transmission is in neutral, go to step 6.
If the transmission is not in neutral, fold open the rubber dust cover and use the gear change tool to shift to neutral so you will be able to start the engine, Refer to *How to Shift Gears Manually*: (page 189).
6. Apply the parking brake.
7. Turn the key to start the engine.
8. Select the gear you want. For running on level ground: 3rd or 4th gear position. For mountain roads: 2nd or 3rd gear. Refer to *How to Shift Gears Manually*: (page 189).
9. Return the gear change tool to its holder under the seat bottom.
10. Install the rubber dust cover.
11. Install the seat bottom.
12. Get into the SXS. Drive it at a safe speed to a place where it can be repaired or serviced.

Emergency Gear Selection & Operation

How to Shift Gears Manually:

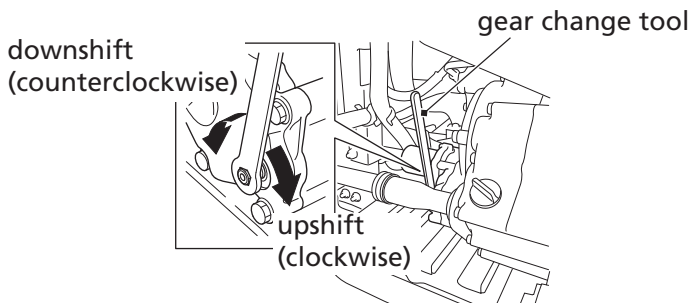

- With the SXS unoccupied, align the hexagonal hole of the gear change tool with the hexagonal end of the secondary spindle which is located on the front crankcase.
- To downshift, turn the gear change tool counterclockwise. To upshift, turn the gear change tool clockwise.
- If the transmission does not shift, rock the vehicle back and forth and try again. If the transmission still will not shift, invert the gear change tool and try again.
- Return the gear change tool to its under seat bottom on the left side.

Do not attempt to shift gears manually using the gear change tool while driving.

If the transmission is shifted manually when the electric shift system is functioning, the system will shutdown automatically and the shift paddles will not operate. To reactivate the system, turn the ignition switch to the "OFF" (O) position, then turn it back to the "ON" (I) position.

If You Have a Flat Tire

How you handle a flat tire on the trail depends on how serious the tire damage is, and what tools and supplies you have with you.

If you have a slow leak or a minor puncture, use the plug method to make a temporary repair. (The plug method is applied from the outside of the tire and is the same as that for conventional tubeless tires.)

A plug-type repair kit, available at most auto parts stores or service stations, provides a plug, an installation tool, tire cement, and an instruction sheet. Follow the instructions provided with the repair kit to make a temporary repair.

As soon as possible, have the tire permanently repaired by your dealer.
Any tire that cannot be repaired should be replaced.

Whenever the Honda SXS is to be operated far from service facilities or available transportation, we recommend that you carry a tire pump and a repair kit with the vehicle.

If the leak is more serious, or a temporary repair doesn't hold, the tire must be replaced. The tire will also need to be replaced if it is damaged (page 156). Replacing a tire involves removing and re-installing the wheel (page 191).

If you are unable to repair a flat tire on the trail, you will need to send for help. We strongly recommend that you do not try to drive with a flat tire. The Honda SXS will be hard to handle, and if the tire comes off the rim, it may lock up the wheel and cause you to crash or overturn.

If You Have a Flat Tire

Emergency Wheel Removal/Installation

Refer to *Safety Precautions* on page 83.

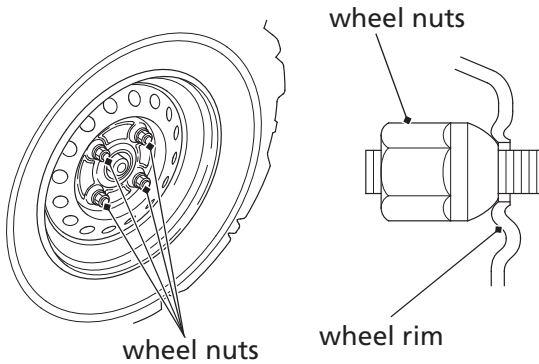

Removal

1. Park your Honda SXS on a firm, level surface.
2. Loosen — but do not remove — the wheel nuts.
3. Raise the front (or rear) wheels off the ground (page 102).
4. Remove the wheel nuts.
5. Remove the wheel.
 - Avoid getting grease, oil, or dirt on the disc or pad surfaces when removing and installing each wheel. Any contamination can cause poor brake performance or rapid pad wear after reassembly.

If You Have a Flat Tire

Installation

1. Position the wheel.
2. Position the wheel nuts so that the tapered sides face the wheel rim.
3. Hand-tighten the wheel nuts on the wheel, then lower the Honda SXS to the ground before tightening the nuts in a crisscross (rather than circular) pattern to the specified torque:
98 lbf·ft (133 N·m, 13.6 kgf·m)

If a torque wrench was not used for installation, see your dealer as soon as possible to verify proper assembly. Improper assembly may lead to loss of control and braking capability.

If the High Coolant Temperature Indicator Lights

Normally, the high coolant temperature indicator will only light momentarily when you turn the ignition ON (I). Occasionally, it may flicker at or near idling speed.

High coolant temperature may be caused by restriction of air flow to the radiator (such as mud caked on the radiator), extended idling, an oil leak, a coolant leak, a low oil level, a low coolant level, or extended operation under adverse conditions.

If the all sections of the coolant temperature gauge including segment H and high coolant temperature indicator are on while you're driving, don't ignore it. Pull safely to a stop. Stop the engine as soon as it's safe to do so, and let it cool.

NOTICE

Continuing to drive with high coolant temperature or an overheated engine can cause serious engine damage.

- A steaming engine indicates a coolant leak. Shut the engine off and wait until the steaming stops. Look for a leak, but don't touch the engine or radiator system. Let everything cool off first.
- Check for any restriction of air flow to the radiator.
- If there's no obvious problem, leave the engine on so the fan and coolant circulating system can continue working. Monitor the coolant temperature gauge and high coolant temperature indicator. The coolant temperature gauge and indicator may return to normal after a brief stop with no load on the engine.
- Check the radiator fan.

If the fan is not working, turn the engine off. Open the fuse box (page 196) and check the radiator fan fuse. If the fuse is blown, replace it with the proper (same rating) spare fuse. Start the engine. If all sections of the coolant temperature gauge including segment H and high coolant temperature indicator are stay on, turn the engine off.

If the radiator fan is working, visually check the coolant level in the reserve tank, located under the front hood. It isn't necessary to touch the radiator system.

If the High Coolant Temperature Indicator Lights

- If the reserve tank is low or empty, don't drive without adding coolant (page 121). After adding coolant, turn the engine on and check the coolant temperature gauge and high coolant temperature indicator.

If the indicator doesn't turn off, do not drive. The engine needs repair.

Transport your Honda SXS to a dealer (page 174).

If the temperature drops to normal, check the coolant level. If it has gone down, add more coolant.

- Check for an oil leak.
- Check the oil level. If necessary, add the recommended oil (page 107) to the upper level mark. If you must leave your Honda SXS to get oil, secure it as much as possible.
- Start the engine, and check that the coolant temperature gauge and high coolant temperature indicator are normal.

If the coolant temperature gauge and indicator return to normal, resume driving. If there is a leak, do not drive the SXS until the leak is repaired by your dealer.

If there's a mild coolant leak, you can drive for a while, carefully watching the coolant temperature gauge and indicator. Be prepared to stop and add more coolant or water. If the leak is bad, transport your Honda SXS to your dealer (page 174).

If a Fuse Blows

All of the electrical circuits on your Honda SXS have fuses to protect them from damage caused by excess current flow (short circuit or overload).

If something electrical on your Honda SXS stops working, the first thing you should check for is a blown fuse.

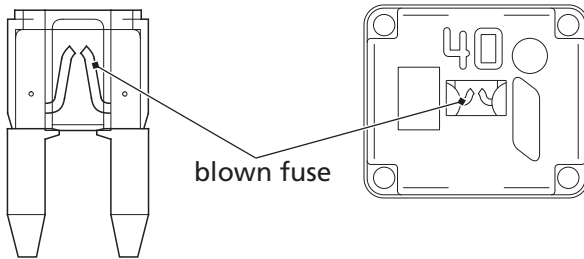

Check all the fuses before looking elsewhere for another possible cause of the problem. Replace any blown fuses and check component operation.

The main fuse and the circuit fuses are located in the battery box under the right side of rear fender.

Recommended Fuses

| | |
|---------------|-------------------------|
| main fuse | 40 A |
| circuit fuses | 30A, 15 A x 4, 10 A x 2 |

If a Fuse Blows

Main Fuse Access

1. To prevent an accidental short circuit, turn the ignition switch OFF (O) before checking or replacing the fuses.
2. To access the main fuse, remove the battery cover (page 164).
3. Remove the fuse cover.
4. Pull the main fuse out. If it is blown, install the spare main fuse. Spare main fuse is located in reverse side of the battery cover.
5. Install the fuse cover.

RIGHT REAR

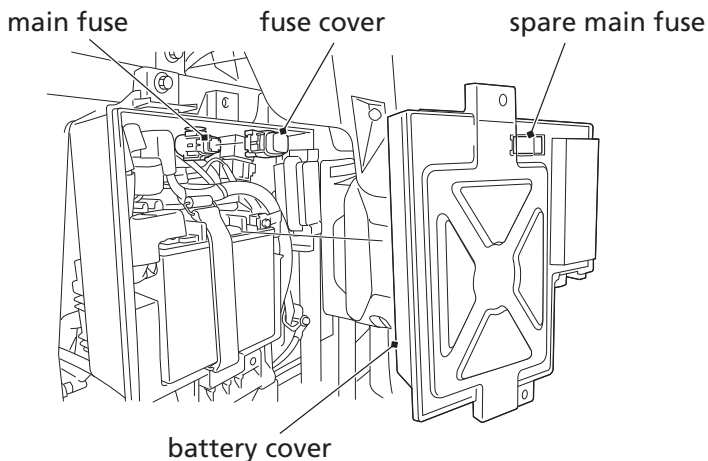

If a Fuse Blows

Circuit Fuse Access

6. To access the circuit fuse, remove the fuse box cover.
7. To check or replace a circuit fuse, pull the old fuse out. If the fuse is blown, replace it with a spare fuse of the same rating. Spare fuses are located in the fuse box.

If you do not have a replacement fuse with the proper rating for the circuit, install one with a lower rating.

NOTICE

Replacing a fuse with one that has a higher rating greatly increases the chance of damage to the electrical system.

8. Install the fuse box cover.
9. Install the battery cover.

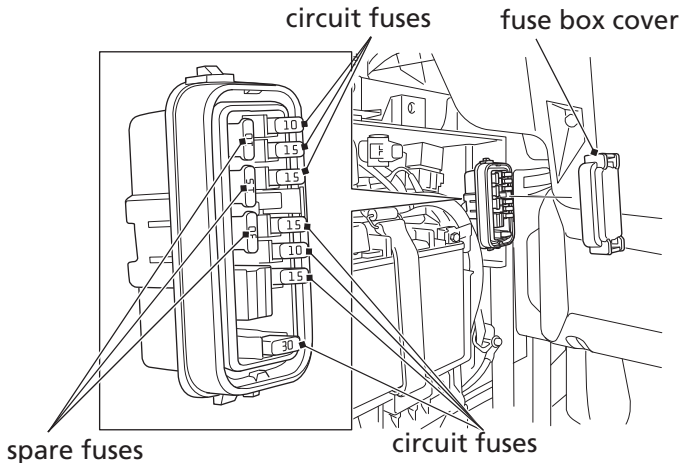

If a Fuse Blows

If you do not have a spare fuse and you cannot drive the Honda SXS without fixing the problem, take a fuse of the same rating or a lower rating from one of the other circuits that you can do without temporarily.

If you replace a blown fuse with a spare fuse that has a lower rating, replace the fuse with the correct rating as soon as you can. Also remember to replace any spare fuses that were installed.

If the replacement fuse of the same rating burns out in a short time, there is probably a serious electrical problem on your Honda SXS. Leave the blown fuse in that circuit and have your Honda SXS checked by your dealer.

If You Crash

Personal safety is your first priority after a crash. If you or anyone else has been injured, take time to assess the severity of the injuries and whether it is safe to continue driving. If you cannot drive safely, send someone for help. Do not drive if you will risk further injury.

If you decide that you are capable of driving your SXS safely, first evaluate the condition of your SXS. If the engine is still running, turn it off and look it over carefully; inspect it for fluid leaks, check the tightness of critical nuts and bolts securing such parts as the steering wheel, control levers, brakes, and wheels.

If there is minor damage, or you are unsure about possible damage but decide to try driving the Honda SXS back to your base, drive slowly and cautiously.

Sometimes, crash damage is hidden or not immediately apparent. When you get home, thoroughly check your Honda SXS and correct any problems you find. Also, be sure to have your dealer check the frame, suspension, seat belts, and occupant protective structure after any serious crash.

If You Lose Your Key

Be sure to record your key number. Store the spare key and recorded key number in a safe location. You'll need this number to have a duplicate key made.

If you lose your key and aren't carrying a duplicate, either get your spare or have one made. If you don't know your key number, call the dealer where you purchased your Honda SXS. They may have it listed in their records. If they don't, transport your Honda SXS to them or the nearest dealer. The dealer will probably have to remove the ignition switch assembly to find the key number so they can make a key for you.

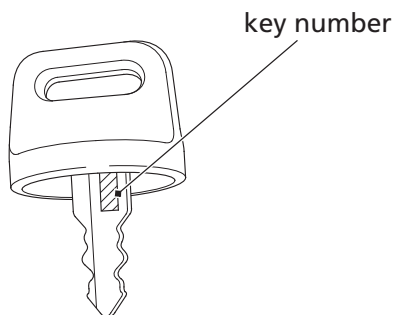

If the Battery Is Low

If the battery is low, the starter motor doesn't operate or works poorly, and you can't start the engine.

Jump starting your Honda SXS should be avoided.

Instead, the battery should be removed and recharged (page 166).

If you can't charge the battery or it appears unable to hold a charge, contact your dealer.

WARNING

The battery gives off explosive hydrogen gas during normal operation.

A spark or flame can cause the battery to explode with enough force to kill or seriously hurt you.

Wear protective clothing and a face shield, or have a skilled mechanic do the battery maintenance.

WARNING: Battery posts, terminals and related accessories contain lead and lead compounds. **Wash your hands after handling.**

However, when there is no option other than jump starting, follow the instructions given below.

NOTICE

If a battery sits in extreme cold, the electrolyte inside can freeze. Attempting to jump start with a frozen battery can cause it to rupture.

Use a battery that is the same as the one in the vehicle or an equivalent.

If the Battery Is Low

1. To prevent an accidental short circuit, turn the ignition switch OFF (O).
2. Remove the battery cover (page 164).
3. Using a fully charged 12-volt battery, connect the positive (+) side of the jumper cable to the charged battery, and connect the positive (+) side on the other end of the jumper cable to the positive (+) terminal of vehicle battery.
4. Connect the negative (-) side of the jumper cable to the charged battery, and connect the negative (-) side on the other end of the jumper cable to the upper muffler cover.
5. After starting the engine, remove the negative (-) sides of the jumper cable from the vehicle and the battery. Then remove the positive (+) sides of the jumper cable from the vehicle battery and the charged battery.
6. Install the battery cover.
 - Do not let the positive (+) side of the jumper cable touch on the negative (-) terminal.
 - If the jumper cable is connected to the battery with the polarity reversed, the battery can explode or the electrical system will be seriously damaged.

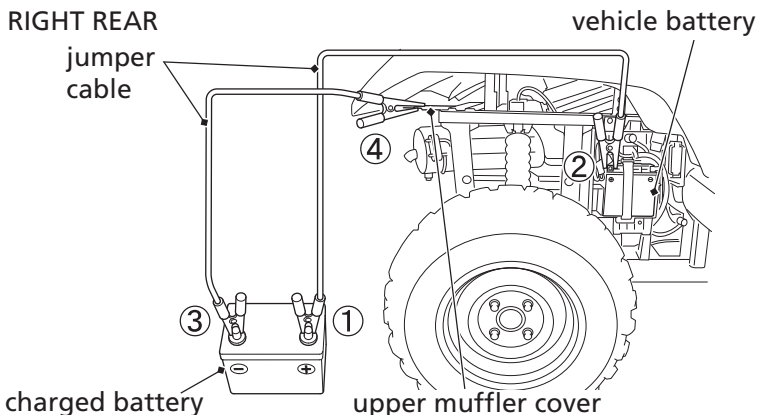

If a Component Fails

The brake lines, control cables, and other components can be damaged as you drive in dense brush or over rocky terrain. Making a trailside repair depends on how serious the damage is and what tools and supplies you have with you.

- If any component in the brake system is damaged, you may have reduced or limited stopping power. If you decide to continue driving back to your base, do so cautiously and at a very low speed.
- If you damage the accelerator cable or other critical component, your Honda SXS may be unsafe to drive. Carefully assess the damage and make any repairs that you can. But if there is any doubt, it's best to be conservative and safe.

Blank page

Technical Information

This section contains dimensions, capacities, and other technical data, plus information on government requirements and how to break-in your Honda SXS.

| | |
|---|-----|
| Vehicle Identification | 206 |
| Specifications | 208 |
| Break-in Guidelines..... | 213 |
| Emission Control Systems (USA & Canada only) | 214 |
| Oxygenated Fuels (USA & Canada only) | 218 |
| Petrol Containing Alcohol (Australia & New Zealand only)..... | 220 |
| Catalytic Converter | 221 |

Vehicle Identification

Serial Numbers

The VIN, engine serial number, and key number may be required when ordering replacement parts. You may record these numbers in the Quick Reference section at the rear of this manual.

The VIN is stamped on the left side of the frame, located under the cargo carrier.

The engine number is stamped on the upper side of the rear crankcase.

LEFT SIDE

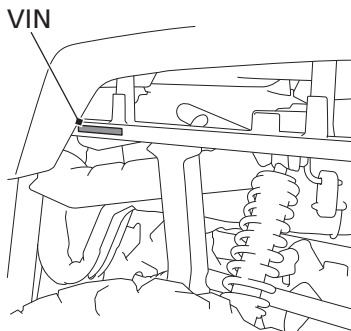

LEFT SIDE

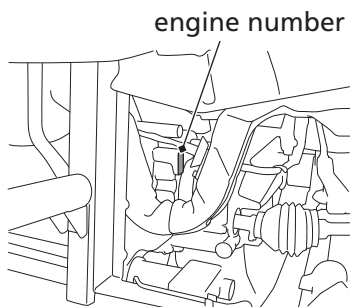

Vehicle Identification

Color Label & Code

The color label is attached to the right front side of the frame.

The color code is helpful when ordering replacement parts. You may record the color and code in the Quick Reference section at the rear of this manual.

Remove the front hood (page 97).

UNDER FRONT HOOD

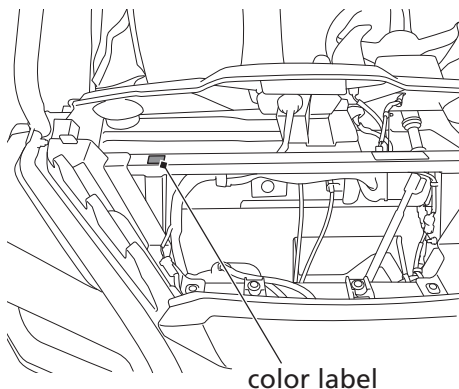

Specifications

| Dimensions | |
|-------------------|---------------------|
| overall length | 102.5 in (2,603 mm) |
| overall width | 50.0 in (1,270 mm) |
| overall height | 71.3 in (1,811 mm) |
| wheelbase | 73.1 in (1,857 mm) |
| ground clearance | 8.5 in (215 mm) |

| Fuel & Lubricants | |
|------------------------------|--|
| fuel recommendation | unleaded gasoline, pump octane number of 86 or higher |
| fuel tank capacity | 3.96 US gal (15.0 ℓ) |
| engine oil capacity | after disassembly: 3.5 US qt (3.3 ℓ) after draining: 3.1 US qt (2.9 ℓ) after draining & oil filter change: 3.2 US qt (3.0 ℓ) |
| engine oil recommendation | API Service Classification SG or higher except oils labeled as energy conserving or resource conserving on the circular API service label, SAE 10W-30, JASO T 903 standard MA, Pro Honda GN4 4-stroke oil (USA & Canada) or Honda 4-stroke oil, or an equivalent |

Specifications

| Fuel & Lubricants (cont'd) | |
|---------------------------------------|--|
| cooling system recommendation | Pro Honda HP Coolant (USA & Canada) or an equivalent high quality ethylene glycol antifreeze containing corrosion protection inhibitors specifically recommended for use in aluminum engines |
| cooling system capacity | 2.5 US qt (2.4 ℓ) |

| Capacities | |
|-------------------------|---|
| passenger capacity | operator and one passenger |
| maximum weight capacity | 880 lb (399 kg) operator, passenger, all cargo and accessories |

| Engine Specifications | |
|------------------------------|---|
| displacement | 29.0 cu-in (475 cm ³) |
| bore & stroke | 3.6 × 2.8 in (92 × 72 mm) |
| compression ratio | 9.5 : 1 |
| spark plug (standard) | BKR5E-11 (NGK) or K16PR-U11 (DENSO) |
| spark plug gap | 0.039 – 0.043 in (1.00 – 1.10 mm) |
| valve clearance (cold) | intake: 0.006 in (0.15 mm) exhaust: 0.009 in (0.23 mm) |
| idle speed | 1,400 ± 100 rpm (NO ADJUSTMENT) |

Specifications

| Power Transmission | | |
|---------------------------|---------|-------|
| primary reduction | | 2.103 |
| secondary reduction | | 1.875 |
| final reduction | front | 4.077 |
| | rear | 4.077 |
| transmission ratio | low | 4.230 |
| | 2nd | 2.388 |
| | 3rd | 1.608 |
| | 4th | 1.178 |
| | 5th | 0.848 |
| | reverse | 5.743 |
| final drive | | shaft |

| Chassis & Suspension | | |
|---------------------------------|----------------|---------------------------------|
| caster | 5° | |
| trail | 1.0 in (26 mm) | |
| tire size | front: | 24X8.00-12 NHS MAXXIS M977H |
| | rear: | 24X10.00-12 NHS MAXXIS M978H |
| tire pressure | front: | 10 psi (70 kPa) |
| | rear: | 10 psi (70 kPa) |

Specifications

| Electrical | |
|-------------------|-------------------------|
| battery | GYZ16H 12V-16 Ah (10HR) |
| generator | 0.481 kW/5,000 rpm |

| Lights | |
|---|-----------------|
| headlight | 12 V 37.5 W x 2 |
| brake/tail light | LED |
| neutral indicator | LED |
| reverse indicator | LED |
| high coolant temperature indicator | LED |
| PGM-FI malfunction indicator lamp (MIL) | LED |
| parking brake indicator | LED |
| seat belt indicator | LED |
| If there is a LED which is not turned on, see your dealer for this service. | |

| Fuses | |
|--------------|-------------------------|
| main | 40 A |
| circuit | 30A, 15 A x 4, 10 A x 2 |

Specifications

| Torque Specification | |
|---------------------------------|---------------------------------|
| right seat bottom cover | 5.9 lbf·ft (8 N·m, 0.8 kgf·m) |
| engine oil drain plug | 18 lbf·ft (25 N·m, 2.5 kgf·m) |
| engine oil filter cover bolts | 9 lbf·ft (12 N·m, 1.2 kgf·m) |
| front final gear oil drain plug | 9 lbf·ft (12 N·m, 1.2 kgf·m) |
| front final gear oil filler cap | 9 lbf·ft (12 N·m, 1.2 kgf·m) |
| rear final gear oil drain plug | 9 lbf·ft (12 N·m, 1.2 kgf·m) |
| rear final gear oil filler cap | 9 lbf·ft (12 N·m, 1.2 kgf·m) |
| wheel nuts | 98 lbf·ft (133 N·m, 13.6 kgf·m) |

Break-in Guidelines

Help assure your Honda SXS's future reliability and performance by paying extra attention to how you drive during the first operating day or 15 miles (25 km).

During this period, avoid full-throttle starts and rapid acceleration.

Emission Control Systems (USA & Canada only)

Exhaust Emission Requirements

The U.S. Environmental Protection Agency (EPA), the California Air Resources Board (CARB), and Environment Canada (EC) require that your Honda off-road utility vehicle comply with applicable emissions standards during its useful life, when operated and maintained according to the instructions provided.

The Vehicle Emission Control Information Label is attached on the left side of the frame, located under the cargo carrier.

LEFT SIDE

vehicle emission control information label
(Canada type only)

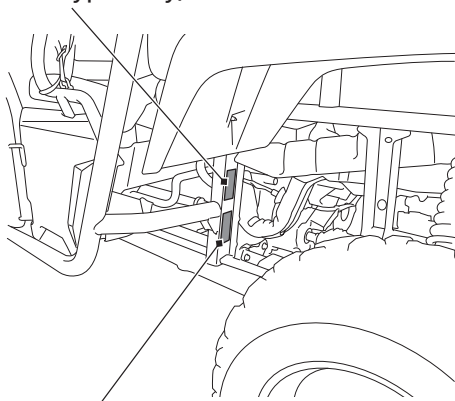

vehicle emission control information label

Emission Control Systems (USA & Canada only)

Source of Exhaust Emissions

The combustion process produces carbon monoxide (CO), oxides of nitrogen (NOx) and hydrocarbons (HC). Control of hydrocarbons and oxides of nitrogen is very important because, under certain conditions, they react to form photochemical smog when subjected to sunlight. Carbon monoxide does not react in the same way, but it is toxic.

Honda Motor Co., Ltd. utilizes various systems to reduce carbon monoxide, oxides of nitrogen and hydrocarbons.

Exhaust Emission Control System

The exhaust emission control system includes an oxygen sensor, a three-way catalytic converter and a PGM-FI system.

No adjustment to this system should be made although periodic inspection of the components is recommended.

The exhaust emission control system is separate from the crankcase emission control system.

Crankcase Emission Control System

The engine is equipped with a closed crankcase system to prevent discharging crankcase emissions into the atmosphere. Blow-by gas is returned to the combustion chamber through the air cleaner.

Emission Control Systems (USA & Canada only)

Problems That May Affect Off-road Utility Vehicle Exhaust Emissions

If you are aware of any of the following symptoms, have the vehicle inspected and repaired by your off-road utility vehicle dealer.

Symptoms:

1. Hard starting or stalling after starting
2. Rough idle
3. Misfiring or backfiring during acceleration
4. After-burning (backfiring)
5. Poor performance (driveability) and poor fuel economy

Federal regulations prohibit removing or disabling a device or element of design that may affect your engine's emission performance unless your Honda off-road utility vehicle will be used exclusively in competition. If you modify your engine for use in sanctioned competition events, you must deface or destroy the emission control information label.

Emission Control Systems (USA & Canada only)

Noise Emission Control System

TAMPERING WITH THE NOISE CONTROL SYSTEM IS PROHIBITED:

State laws prohibit, or Canadian provincial laws may prohibit, the following acts or the causing thereof: (1) The removal or rendering inoperative by any person, other than for purposes of maintenance, repair or replacement, of any device or element of design incorporated into any new vehicle for the purpose of noise control prior to its sale or delivery to the ultimate purchaser or while it is in use; or (2) the use of the vehicle after such device or element of design has been removed or rendered inoperative by any person.

AMONG THOSE ACTS PRESUMED TO CONSTITUTE TAMPERING ARE THE FOLLOWING ACTS:

- Removal of, or puncturing the muffler, baffles, header pipes or any other component which conducts exhaust gases.
- Removal of, or puncturing of any part of the intake system.
- Lack of proper maintenance.
- Removing or disabling any emissions compliance component, or replacing any compliance component with a non-compliant component.

Fuel Permeation Emission Control System

This vehicle complies with the Fuel Permeation Emission Control regulations of the U.S. Environmental Protection Agency (EPA), the California Air Resources Board (CARB), and Environment Canada (EC).

The fuel tank, fuel hoses, and fuel vapor charge hoses used on this vehicle incorporate fuel permeation control technologies.

Tampering with the fuel tank, fuel hoses, or fuel vapor charge hoses to reduce or defeat the effectiveness of the fuel permeation technologies is prohibited by federal regulations.

Oxygenated Fuels (USA & Canada only)

Some conventional gasolines are being blended with alcohol or an ether compound. These gasolines are collectively referred to as oxygenated fuels. To meet clean air standards, some areas of the United States and Canada use oxygenated fuels to help reduce emissions.

If you use an oxygenated fuel, be sure it is unleaded and meets the minimum octane rating requirement.

Before using an oxygenated fuel, try to confirm the fuel's contents. Some states/provinces require this information to be posted on the pump.

The following are the EPA-approved percentages of oxygenates for non-road vehicles:

ETHANOL (ethyl or grain alcohol) up to 10% by volume

You may use gasoline containing up to 10% ethanol by volume.

Gasoline containing ethanol may be marketed under the name "Gasohol".

Do not use gasoline containing more than 10% ethanol by volume.

The use of gasoline containing a higher percentage (e.g. E15, E20, E85) of ethanol has not been approved for use in this vehicle and may cause starting and/or performance problems and can also damage metal, rubber, and plastic parts of the fuel system and are not be covered by the Distributor's Limited Warranty.

Oxygenated Fuels (USA & Canada only)

METHANOL (methyl or wood alcohol) up to 5% by Volume
You may use gasoline containing methanol containing up to 5% methanol by volume as long as it also contains cosolvents and corrosion inhibitors to protect the fuel system. Gasoline containing more than 5% methanol by volume may cause starting and/or performance problems. It may also damage metal, rubber, and plastic parts of your fuel system.

If you notice any undesirable operating symptoms, try another service station or switch to another brand of gasoline.

Fuel system damage or performance problems resulting from the use of an oxygenated fuel containing more than the percentages of oxygenates mentioned above are not covered under warranty.

Oxygenated fuels can damage paint and plastic. Be careful not to spill fuel when filling the fuel tank. Wipe up any spills immediately.

NOTICE

Oxygenated fuels can damage paint and plastic. Damage caused by spilled fuel is not covered by warranty.

Petrol Containing Alcohol (Australia & New Zealand only)

If you decide to use a petrol containing alcohol (gasohol), be sure its octane rating is at least as high as that recommended.

There are two types of gasohol: One contains ethanol, and the other contains methanol. Do not use gasohol that contains more than 10% ethanol. Do not use gasohol that contains methanol (methyl or wood alcohol) unless it also contains cosolvents and corrosion inhibitors for methanol. Never use petrol containing more than 5% methanol, even if it has cosolvents and corrosion inhibitors.

Engine performance problems resulting from the use of fuels that contain alcohol are not covered under the warranty. Honda cannot endorse the use of fuels containing methanol since evidence of their suitability is not yet complete.

Before buying fuel from an unfamiliar station, try to find out if the fuel contains alcohol. If it does, confirm the type and percentage of alcohol used. If you notice any undesirable operating symptoms while using a petrol that contains alcohol, or one that you think contains alcohol, switch to a petrol that you know does not contain alcohol.

Catalytic Converter

This SXS is equipped with the three way catalytic converter. The catalytic converter contains precious metals that serve as catalysts, promoting chemical reactions to convert the exhaust gasses without affecting the metals.

The catalytic converter acts on HC, CO, and NOx. A replacement unit must be an original Honda part or its equivalent.

The catalytic converter must operate at a high temperature for the chemical reactions to take place. It can set fire to any combustible materials that come near it. Park your SXS away from high grasses, dry leaves, or other flammables.

A defective catalytic converter contributes to air pollution, and can impair your engine's performance. Follow these guidelines to protect your SXS's catalytic converter.

- Always use unleaded gasoline. Even a small amount of leaded gasoline can contaminate the catalyst metals, making the catalytic converter ineffective.
- Keep the engine in good running condition. A poorly running engine can cause the catalytic converter to overheat causing damage to the converter or the SXS.
- If your engine is misfiring, backfiring, stalling, or otherwise not running properly, stop riding and turn off the engine. Have your SXS serviced as soon as possible.

Blank page

Consumer Information (USA & Canada only)

This section contains information on your warranty and how to get an official Honda service manual.

| | |
|--|-----|
| Authorized Manuals (USA & Canada only) | 224 |
| Warranty Coverage (USA & Canada only) | 225 |
| Warranty Service (USA & Canada only) | 226 |
| Contacting Honda (USA & Canada only)..... | 227 |
| Your Honda Dealer (USA & Canada only)..... | 228 |
| The Honda Rider's Club (USA only)..... | 229 |

Authorized Manuals (USA & Canada only)

The Service Manual used by your authorized dealer is available from your Honda dealer or Helm, Inc. (USA only, Canada: See your dealer to order authorized manuals.)

Also available but not necessary to service your model is the Honda Common Service Manual which explains theory of operation and basic service information for various systems on Honda motorcycles, scooters, ATVs, SXSs and PWCs.

The Winter Storage Guide in conjunction with the Owner's Manual and Service Manual can help you prepare your Honda motorcycle, scooter, ATV, and SxS for winter storage.

These Honda manuals are written for the professional technician, but most mechanically capable owners should find them easy to use if they have the proper tools and observe proper safety standards. Special Honda tools are necessary for some procedures.

| Publication Item No. | Description |
|-----------------------------|-------------------------------------|
| 61HL501 | 2016 SXS500M PIONEER Service Manual |
| 61CSM00 | Common Service Manual |
| S9507 | Winter Storage Guide |
| 31HL5900 | 2016 SXS500M PIONEER Owner's Manual |

Order On-Line: www.helminc.com

Order Toll Free: 1-888-CYCLE93 (1-888-292-5393)

(NOTE: For Credit Card Orders Only)

Monday - Friday 8:00 AM - 6:00 PM EST

Warranty Coverage (USA & Canada only)

Your new Honda is covered by these warranties:

- Honda SXS Limited Warranty
- Emission Control System Warranty

There are responsibilities, restrictions, and exclusions which apply to these warranties. Please read the Warranties Booklet given to you by your Honda dealer at the time of purchase. Be sure to keep your Honda owner's card with your Warranties Booklet.

Canada: Please refer to the Warranty Booklet posted on our website at www.honda.ca.

It is important to realize that your warranty applies to defects in material or workmanship of your Honda. Your warranty coverage does not apply to normal wear or deterioration associated with using the Honda SXS.

Your warranty coverage will not be voided if you choose to perform your own maintenance. However, you should have the proper tools and service information and be mechanically qualified. Failures that occur due directly to improper maintenance are not covered.

Almost all of your warranty coverage can be extended through the Honda Protection Plan (USA only). For more information, see your dealer.

Warranty Service (USA & Canada only)

Please remember that recommended maintenance interval servicing is not included in your warranty coverage. Additionally, your warranty does not apply to the normal wear of items (such as brakes, tires, etc.).

If you believe you have a problem with your Honda SXS, call the service department of your dealer. Make an appointment for an inspection and diagnosis. Remember, as the owner of the Honda SXS, you will be asked to authorize that inspection. Your dealer will give you the results of the inspection. If the problem is covered under warranty, your dealer will perform the warranty repairs for you.

If you have questions about warranty coverage or the nature of the repair, it is best to talk to the Service Manager of your dealer.

Sometimes, in spite of the best intentions of all concerned, a misunderstanding may occur. If you aren't satisfied with your dealer's handling of the situation, we suggest you discuss your problem with the appropriate member of the dealership's management team. If the problem has already been reviewed with the Service Manager, Parts Manager, Sales Manager, etc., contact the Owner of the dealership or their designated representative.

Contacting Honda (USA & Canada only)

Your owner's manual was written to cover most of the questions you might ask about your Honda. Any questions not answered in the owner's manual can be answered by your dealer. If your dealer doesn't have the answer right away, they will get it for you.

If you have a difference of opinion with your dealer, please remember that each dealership is independently owned and operated. That's why it's important to work to resolve any differences at the dealership level.

If you wish to comment on your experiences with your Honda or with your dealer, please send your comments to the following address:

Motorcycle Division, American Honda Motor Co., Inc., P.O. Box 2200, Torrance, CA 90509-2200, mailstop: 100-4C-7B, telephone: (866) 784-1870.

Canada: Honda Canada Inc., Customer Relations Dept, 180 Honda Boulevard, Markham, Ontario L6C 0H9, telephone: (888) 946-6329, facsimile: (877) 939-0909.

E-mail: honda_cr@ch.honda.com

Please include the following information in your letter:

- name, address, and telephone number
- product model, year, and VIN
- date of purchase
- dealer name and address

We will likely ask your dealer to respond, or possibly acknowledge your comments directly.

Your Honda Dealer (USA & Canada only)

Once you purchase your new Honda, get familiar with the organization of your Honda dealer so you can utilize the full range of services available.

The service department is there to perform regular maintenance and unexpected repairs. It has the latest available service information from Honda. The service department will also handle warranty inspections and repairs.

The parts department offers Honda Genuine Parts, Pro Honda products, Honda Genuine Accessories, and Honda Signature Accessories (USA only), and Honda accessories and products (Canada only). The same quality that went into your Honda can be found in Honda Genuine replacement parts. You'll also find comparable quality in the accessories and products available from the parts department.

The sales department offers the Honda Protection Plan to extend almost all of your warranty coverage (USA only).

We're sure you'll be as pleased with the service your Honda dealer continues to provide after the sale as you are with the quality and dependability of your Honda.

The Honda Rider's Club (USA only)

The Honda Rider's Club of America (HRCA) sponsors local riding chapters at Authorized Honda Dealerships across the country.

Index

A

| | |
|-----------------------------------|-----|
| accessories | 4 |
| accessory power socket | 47 |
| age and size recommendation | 2 |
| air cleaner, | |
| body | 127 |
| filter | 125 |
| housing drain tube | 129 |
| air pressure, tire | 154 |
| American Honda, contacting | 227 |
| apparel, protective | 51 |
| appearance care | 167 |
| authorized manuals | 224 |

B

| | |
|------------------------------------|-----|
| battery | 162 |
| brakes, | |
| fluid | 146 |
| pad wear | 149 |
| parking brake lever | 36 |
| parking brake lever freeplay | 151 |
| pedal inspection | 150 |
| break-in guidelines | 213 |

C

| | |
|---------------------------------|-------|
| capacity, fuel | 104 |
| care, appearance | 167 |
| cargo, | |
| limit | 3, 57 |
| catalytic converter | 221 |
| cleaning, appearance care | 167 |
| climbing hills | 75 |
| clip removal | 101 |

Index

| | |
|---------------------------------|-----|
| color label | 207 |
| compartment, | |
| owner's manual | 96 |
| storage | 46 |
| tool kit | 95 |
| component fails | 203 |
| consumer information | 223 |
| coolant temperature gauge | 25 |
| crash, if you | 199 |
| crossing a hill | 77 |
| customer service | 227 |

D

| | |
|---|-----------|
| differential oil (front final gear) | 116, 118 |
| digital clock | 23 |
| dipstick | 109 |
| doors | 37 |
| drive mode select lever | 33 |
| driveshaft boots | 161 |
| driving, | |
| basic operations | 61 |
| clothing | 2, 50, 51 |
| precautions | 70 |
| preparing for | 172 |
| safety | 2 |
| through water | 78 |

E

| | |
|--------------------------------|-----|
| emission control systems | 214 |
|--------------------------------|-----|

Index

| | |
|-------------------|-----|
| engine, | |
| number | 206 |
| oil | 106 |
| pinging | 103 |
| starting | 62 |
| stopping | 62 |
| won't start | 184 |
| environment | 180 |

F

| | |
|----------------------------------|-----|
| flat tire | 190 |
| four wheel drive indicator | 29 |
| fuel gauge | 21 |
| fuel, | |
| fill cap | 104 |
| oxygenated | 218 |
| recommendation | 103 |
| tank capacity | 104 |
| fuses | 195 |

G

| | |
|-------------------------------|----------|
| gap, spark plug | 138, 209 |
| gasohol | 218 |
| gasoline | 103 |
| gear position display | 29 |
| gear position indicator | 29 |

H

| | |
|------------------------|----|
| headlight switch | 31 |
|------------------------|----|

Index

| | |
|---------------------------|----|
| hill, | |
| approaching a hill | 75 |
| crossing a hill | 77 |
| driving down a hill | 76 |
| driving up a hill | 76 |
| stopping on a hill | 76 |
| hourmeter | 27 |

I

| | |
|---|---------|
| identification, vehicle | 206 |
| ignition switch | 30 |
| indicators, | |
| gear position indicator | 29 |
| high coolant temperature indicator | 15, 193 |
| neutral indicator | 15 |
| parking brake indicator | 15 |
| PGM-FI malfunction indicator lamp (MIL) | 15 |
| reverse indicator | 15 |
| seat belt indicator | 15 |
| inspection, pre-drive | 54 |

K

| | |
|-----------------|-----|
| key, | |
| lost | 200 |
| number | 200 |
| kit, tool | 95 |

L

| | |
|--------------------------|-------|
| labels, safety | 6 |
| limit, cargo | 3, 57 |
| loading guidelines | 58 |

Index

| | |
|------------------------|----------|
| lubrication, | |
| differential oil | 116, 118 |
| engine oil | 107 |
| points | 130 |

M

| | |
|------------------------------------|--------|
| maintenance, | |
| importance | 81 |
| maintenance minder indicator | 28, 85 |
| precautions | 83 |
| record | 89 |
| safety | 82 |
| schedule | 84 |
| manual, service | 224 |
| maximum weight limit | 3, 57 |
| modifications | 5 |
| multi-function display | 18 |

N

| | |
|--------------------------------------|-----|
| neutral indicator | 15 |
| noise emission control systems | 217 |
| numbers, serial | 206 |

O

| | |
|--|----------|
| obstacles, avoiding | 77 |
| odometer | 24 |
| odometer display | 20 |
| oil, | |
| differential | 116, 118 |
| engine | 107 |
| front final gear | 116 |
| high coolant temperature indicator | 15, 193 |
| rear final gear | 118 |

Index

| | |
|------------------------------|-----|
| owner's manual storage | 96 |
| oxygenated fuels | 218 |

P

| | |
|------------------------------------|-----|
| parking | 69 |
| passenger, | |
| handhold | 45 |
| no carrying in cargo carrier | 3 |
| pedal, accelerator | 133 |
| petrol containing alcohol | 220 |
| pinging, engine | 103 |
| plug, spark | 137 |
| pre-drive inspection | 54 |
| problems, unexpected | 182 |
| protective apparel | 51 |

R

| | |
|-------------------------|--------|
| removal, seat | 98 |
| reverse indicator | 15 |
| reverse lever | 35, 67 |

S

| | |
|-----------------------------|-----|
| safety, | |
| driving precautions | 70 |
| important precautions | 83 |
| labels | 6 |
| schedule, maintenance | 84 |
| seat, | |
| belts | 41 |
| removal | 98 |
| serial numbers | 206 |

Index

| | |
|---------------------------|----------|
| service, | |
| customer | 227 |
| manuals | 224 |
| warranty | 226 |
| shift paddle | 32, 64 |
| side nets | 38 |
| spark arrester | 140 |
| spark knock | 103 |
| spark plug | 137 |
| specifications | 208 |
| speedometer | 19 |
| speedometer display | 19 |
| starting, | |
| engine | 62 |
| troubleshooting | 184 |
| stopping engine | 62 |
| storage, | |
| owner's manual | 96 |
| SXS | 176 |
| suspension, | |
| adjustment | 143, 144 |
| spring pre-load | 143, 145 |
| switch, | |
| headlight | 31 |
| ignition | 30 |

T

| | |
|-------------------------|----------|
| tires, | |
| air pressure | 154 |
| flat | 190 |
| repairing | 158 |
| replacing | 159 |
| thread conditions | 156, 157 |

Index

| | |
|---------------------------------|-----|
| tool kit | 95 |
| trailer hitch | 48 |
| trailer towing, | |
| operational guidelines | 59 |
| weight limits | 59 |
| transporting your Honda | 174 |
| tripmeter | 24 |
| trouble, unexpected | 181 |
| troubleshooting, starting | 184 |
| turning, on level ground | 74 |

V

| | |
|--|-----|
| vehicle identification no. (VIN) | 206 |
|--|-----|

W

| | |
|------------------------------|-----|
| warning labels | 6 |
| warranty, | |
| coverage | 225 |
| extended | 225 |
| service | 226 |
| washing your SXS | 168 |
| water, driving through | 78 |
| weight limit | 57 |
| wheel removal | 191 |

Quick Reference

The following is a brief, but important collection of information you need to know about your Honda. You'll also find space to record important notes.

How To Avoid Costly Repairs

The engine of your Honda can be the most expensive component to repair. Proper maintenance, especially the use of the recommended fluids and filters, prevents premature wear and damage.

Frequent causes of costly repairs are:

- Engine oil — insufficient quantity, improper oil.
- Air cleaner — dirty, leaking because of improper installation (poor seal).

Record important information on the following page:

Quick Reference

| | |
|---------------|--|
| Engine No. | |
| VIN | |
| Color Label | |
| Owner's Name | |
| Address | |
| City/State | |
| Phone | |
| Dealer's Name | |
| Address | |
| City/State | |
| Phone | |
| Service Mgr. | |

Quick Reference

| | |
|-------------------------|--|
| Scheduled Maintenance | Initial: 100 miles (150 km) Regular: every 600 miles (1,000 km) |
| Pre-drive Inspection | Each time before you drive (page 54): tires, fuel level, oil level, underbody, air cleaner housing drain tube, coolant, brake fluid, driveshafts, suspension, exhaust system, wheels, lights, controls, seat belts. |
| Fuel/Capacity | Unleaded gasoline, pump octane number 86 or higher 3.96 US gal (15.0 l) |
| Engine Oil/ Capacity | API Service Classification SG or higher except oils labeled as energy conserving or resource conserving on the circular API service label, SAE 10W-30, JASO T 903 standard MA, Pro Honda GN4 4-stroke oil (USA & Canada) or Honda 4-stroke oil, or an equivalent after draining & oil filter change: 3.2 US qt (3.0 l) |
| Maximum Weight Capacity | 880 lb (399 kg) operator, passenger, all cargo and accessories |

Quick Reference

| | |
|----------------------|---|
| Tires | Front: 24X8.00-12 NHS MAXXIS M977H Rear: 24X10.00-12 NHS MAXXIS M978H |
| Tire Pressure (cold) | Front: 10 psi (70 kPa) Rear: 10 psi (70 kPa) |
| Spark Plugs | standard: BKR5E-11 (NGK) or K16PR-U11 (DENSO) |
| Coolant | Ethylene glycol antifreeze (silicate-free) for aluminum engines in 50/50 solution with Pro Honda HP Coolant or an equivalent distilled water |
| Fuses | main: 40 A circuit: 30A, 15 A x 4, 10 A x 2 |

Quick Reference

These symbols are used in Driver Controls section:

| SYMBOL | COMPONENT | SEE PAGE |
|---------------|--------------------------|-----------------|
| II | START — ignition switch | 30 |
| I | ON — ignition switch | 30 |
| O | OFF — ignition switch | 30 |
| O | OFF — headlight switch | 31 |
| ☀ | ON — headlight switch | 31 |
| + | Up — right shift paddle | 32 |
| — | Down — left shift paddle | 32 |
| R | reverse lever | 35 |