



Pointmaker[®] CR-100

Courtroom Annotation System

User Guide

The CR-100 is a dynamic product, with features added on a regular basis. The latest version of this manual will be posted for download at pointmaker.com, on its product page.

Copyright

© 2016 by Pointmaker LLC
4650 S. Butterfield Drive, Tucson, AZ 85714-3403

800-552-2262
(520) 745-0001
Fax (520) 745-0004
www.pointmaker.com

No part of this publication may be reproduced, transmitted, transcribed, stored in a retrieval system or translated into any language in any form by any means without the expressed written permission of Pointmaker LLC

Pointmaker® is a registered trademark of Pointmaker LLC, of Tucson, Arizona. All other trademarks are the property of their respective companies.

CONTENTS

Section One:

Getting Started	1
Introduction	3
Live Streaming Annotation System with iPad Control, Capture, Print and Network Capabilities.....	3
Features.....	4
Controllers/Markers Overview.....	7
DTU-30 Digitizing Tablet	7
KB-30 Keyboard	8
Touch Screens and Whiteboards.....	10
Mouse Devices	11

Section Two:

Installation.....	15
General Installation	17
Connecting the Video Source and Outputs.....	17
Connecting Controllers.....	18
Videoconferencing	21
Power Up	21

Section Three:

CR-100 Menu System	23
Overview	25
Using the CR-100 Menu System	27
Default User Settings	27
Menu Basics.....	27
Preparing the CR-100 for Use	31
Customizing the Color Palette	31
Selecting a Brightness Level.....	33
Changing Pen Proximity	35
Setting Video Output.....	35
Zap Icon Toggle	37
EDID.....	38
HDCP Input/Output	40
Background Options.....	41
Touch Screen Command Areas	42
System Info.....	43
Capture Options.....	44
Setting the Destination for Saved Files	46
Setting the Verify Option	46
Calibrating CR-100 Controllers.....	47
Serial Port Settings	50
Setting the Tablet Template	57
Network Features	58
Printer Setup	60
Multipoint	61

Section Four:	
Using Markers	67
Overview	69
Assigning Marker Appearance.....	71
Assigning Marker Colors.....	71
Assigning Line Styles.....	72
Selecting Pointers.....	74
Turning the Active Pointer On/Off.....	75
Marking.....	77
Entering the Marking Mode.....	77
Pointing.....	77
Drawing.....	78
Typing Text Labels.....	79
Sizing and Anchoring Frames.....	80
Stamping the Date/Time.....	81
Clearing Markers.....	83
Clearing All Markers.....	83
Undoing a Marker.....	83
Erasing Markers.....	84
Using The Chalkboard.....	87
Activating the Chalkboard.....	87
Displaying Different Overlays.....	88
Paging Through Overlays.....	89
Turning Off the Marker Overlay.....	89
Section Five:	
Image Mobility	91
Overview	93
Image Manipulation.....	95
Freezing Video.....	95
Saving Images.....	95
Retrieving Images.....	98
Printing Images.....	100
Sending Images.....	101
Verifying Saved or Printed Images.....	101
Section Six:	
Using RS-232 Commands.....	103
Overview.....	105
X-Y Coordinate Grid.....	106
(A) Autodetect Video Input.....	106
(AI) Audio Input.....	107
(AO) Audio Output.....	107
(AOV) Audio Volume.....	108
(B) Background.....	108
(CA) Calibrations.....	108
(CD) Calibration Types.....	109
(CE) Color Enable.....	109
(CL) Clear.....	110
(CM) Marker Move.....	110
(CPF) Freeze.....	110
(CPI) Read Specific Image From USB.....	110
(CPN) Read Specific Image From TFTP.....	111
(CPP) Print Current Image.....	111
(CPRD) Read Current Image from USB.....	111
(CPRS) Read Current Image from SMB.....	111

(CPRT) Read Current Image from TFTP	112
(CPSD) Store Current Image to USB.....	112
(CPSS) Store Current Image to SMB	112
(CPST) Store Current Image to TFTP	112
(CPW) Read Specific Image From SMB.....	113
(CS) Color Selection	113
(DCT/DCA) Device Type COMM	114
(DL) Draw Line.....	115
(DP) Drop Marker.....	116
(DUI/DUP) Device Type USB	116
(E) Echo.....	118
(EM) Erase Method	118
(ESP, ESA) Video Streaming (CPN-6000).....	119
(FS) Frame Size	119
(FT) Frame Type.....	119
(HI) HDCP Input setting for each HDMI input port	120
(I) Marker Intensity or Brightness	120
(IFD) Set Image File Directory.....	120
(IFI) Set Image File Index	121
(IFP) Set Image File Prefix.....	121
(IM) Identify Mode for Multiple Users	121
(L) Line Style	122
(K) Keyboard Input.....	122
(M) Video Input Type.....	123
(ME) Verify Dialog Response	123
(PA) Pass-through	124
(PT) Pointer Type	124
(PX) Proximity On/Off.....	125
(R) Restart Pointmaker.....	125
(S) Date/Time Marker	125
(SCO) Scaler Output Format.....	126
(SUM) Menu System	127
(T) Text Label	127
(TA) Template Change.....	128
(TC) Touch Screen Corner Control	128
(TCA) Touch Screen Function Areas.....	129
(TR) Touch Screen Right Click Emulation	130
(U) Undo/Erase.....	130
(V) Select an Overlay	131
(VCD) Display Change of Video Input.....	131
(VI) Video Input.....	131
(VIH) Enable or Disable HDCP Input	132
(VSW) Initiate Wait Before Video Switching	132

Appendix 133

Troubleshooting Guide.....	135
Updating the CR-100.....	137
Quick Reference for Devices.....	139
Quick Reference for Digitizing Tablet	139
Quick Reference for Keyboard	141
Quick Reference for Touch Screens and Whiteboards.....	142
Quick Reference for Other Mouse Devices.....	142
Symbol Font Chart	145
Map Font Chart	147
RS-232 (COMM Port) Pinout	149
Glossary.....	151

Outside copyright information for software included with the CR-100155

SECTION ONE:
GETTING STARTED

INTRODUCTION

The Pointmaker® CR-100 is a professional, hardware-based video processor, designed so that users can display and share content from an iPad, as well as from multiple video and computer sources. This model also has the ability to change settings, switch video sources and annotate from the convenience of an iPad. Pointmakers are valuable assets in courtrooms, boardrooms, classrooms, city council chambers, government training facilities, sports or weather broadcasts, video conferences, and more.

Live Streaming Annotation System with iPad Control, Capture, Print and Network Capabilities

The CR-100 gives the user the ability to capture, print and share annotated images directly from the Pointmaker unit. An annotated image may be “captured” by saving it to a USB storage device, like a flash drive. You can print annotated images to a color PostScript printer. The printer must be connected either over a TCP/IP network, or directly through the Pointmaker unit’s USB port to a IEEE1284 port on the printer. Images are easily shared over a TCP/IP network or through the mobility of the USB storage device, which is easily transported or connected to a computer. With a separately purchased iPad, you can download and use the Pointmaker PVI Control app to annotate and control the Pointmaker from anywhere in the room.

Marking devices

Drawing lines and markers are controlled by the user during a presentation with an optional USB digitizing tablet (DTU-CTL470). The included keyboard provides a few more marking features as noted below. The CR-100 is also compatible with most touch screens and mouse devices.

All Pointmaker video markers offer several simple-to-use graphics, called markers. There are two types of markers with which to annotate a video image: pointers and freehand drawing. Among the 12 pointers available, there is a selection of 8 arrows, each oriented at a different angle; 2 dot pointers, small and large; and 2 cross hair pointers, small and large. Of course, there is an option to display no pointer at all. The second marking capability is freehand drawing. You can select to draw in 1 of 4 different line widths, with or without drop shadows.

When the keyboard is attached, it enables four additional marker types: frames, text, a date/time stamp, and straight line drawing. Frames include boxes and circles which can be sized in advance of a presentation, then used to frame or fill certain areas of the video image. Using the keyboard, presenters may type alphanumeric text directly on the video image, or select an active date and time label that

can time events displayed on the monitor or screen. Straight line drawing is also available in three different line widths.

Pointers and drawings may be used in combination to annotate the image. As easily as the markers are created, so are they easily erased, either one at a time until the screen is clear, or all at once. Markers are actually drawn onto clear “overlays.” The system supports up to 25 different marker overlays, which can be stored ahead of time and then recalled during the presentation.

Markers can be created in 7 different colors, or 3 different highlight colors, useful to help separate points being made, or to increase contrast with the background image. And, if a video image is not desired, presenters may call up a white background on the screen and use it like a whiteboard on which to “draw out” your point.

The Pointmaker CR-100 is compatible with most HDMI sources and displays.



Figure 1-1: Back Panel

iPad Server Options

The CR-100 contains an iPad server which supports remote control of certain features within the unit, along with annotation, all through an iPad app. Operation of iPad app features is featured within the app’s Help area. For more information, please see our website at www.pointmaker.com/servers for further information, or contact a sales representative.

NOTE: Because of the streamlined nature of the CR-100, there is limited functionality with PVI Control iPad app

Features

- **Two marking tools**

Freehand drawing mode in four different line thicknesses; fine, medium and bold, with or without a drop shadow.

Pointers including arrows, dots and cross hairs, which may be moved or anchored anywhere on the screen. Arrows may be preset to point in one of

8 different angles. Dots and cross hairs may be pre-selected in a small or large size.

- **Four additional marking tools with keyboard connected**

Straight line drawing mode allows underscoring, mapping or otherwise drawing a straight line. Three different line thicknesses are available: fine, medium and bold, with or without a drop shadow.

Text can be typed on the video image in one of 6 different fonts, each available in one or more sizes. A text background may be added to further highlight the text on the video image.

Frames in the shapes of circles or boxes may be sized and positioned to call attention to an area within the frame. Filled frames or fills allow presenters to block out portions of the video image, useful in classroom exams or in blocking out extraneous visuals.

An active date/time label, sometimes called a date/time stamp, can be placed on the video image to time an event. This label is very useful for record keeping when saving or printing images because it is embedded in the image.

- **The ability to position and anchor a combination of several markers and drawings on the screen at once.**
- **Easily capture or print annotated images.**
- **Options for clearing lines and pointers from an overlay all at once or one at a time, beginning with the most recently anchored marker.**
- **Ability to assign a unique marker color (up to 7) to each marking device.**
- **On an optional digitizing tablet, an additional 3 highlight colors can be used to create a see-through colored overlay, just like “Highlighters” on paper.**
- **A drop shadow effect may be selected to further optimize the display of drawn lines.**
- **With keyboard connected or when used with AMX/Crestron controller, or other control system, you have the ability to store up to 25 different marker overlays of Pointmaker markers so that presentations may be prepared in advance. Without the keyboard attached, only one overlay is supported.**
- **Compatibility with HDMI equipment.**
- **A solid white chalkboard can be selected for drawing when the video image is no longer needed.**

- Sync generation allows the Pointmaker to automatically select the sync if no live video is desired. In the event that sync from a poor video source is lost, the Pointmaker will automatically switch to chalkboard mode if auto-chalkboard is enabled.
- Keyboard control provides a quick way to select many of the Menu System options without having to go to the Menu System. Instead, function keys provide choices for pointer type, background, marker colors, brightness levels, video source selection and more.
- Pen Proximity feature allows tablet users to determine what happens to the active pointer as the pen is moved away from the tablet. The pointer can be made to disappear as the pen is pulled away, or to remain on the video image, ready for positioning
- Brightness adjustment gives you the opportunity to set the brightness of the Pointmaker markers to coincide with the brightness level of the video signal, so that the markers are displayed optimally for standard video or for professional broadcasting.
- A/V programmable so that A/V remote control systems can control the Pointmaker using commands supplied in this manual.
- Two RS-232 ports allow the simultaneous use of two RS-232 tablets or RS-232 touch screens (or other RS-232 communications devices).
- Four USB 3.0 ports allow the simultaneous use of up to four USB tablets, USB touch screens, or other USB control devices. The use of USB hubs increases the device limit to multiple USB control devices.
- Options available to multiple users to designate which RS-232 tablet or touchscreen takes priority over the other when both are drawing.

	B	C	D	E	F	G	H	I	J	K	L
1	J	F	A	M	J	J	A	S	Total	Projected	
2	8.25	26.50	78.75	26.50	23.25	19.75	32.25	3.50	0.00	221.75	644.00
3	29.50	16.50	0.50	27.25	33.25	21.25	31.00	44.75	0.00	172.50	332.00
4	26.75	5.75	12.75	19.50	0.00	2.00	0.50	28.50	0.00	140.00	212.00
5	19.50	8.00	11.00	19.75	26.50	22.75	3.00	20.25	0.00	130.75	303.00
6	2.25	0.50	1.50	1.00	0.50	9.00	4.50	0.00	0.00	22.25	40.00
7	17.50	14.00	2.75	25.00	13.25	13.50	2.50	13.00	0.00	104.25	260.00
8	7.00	8.75	3.00	23.75	14.75	2.50	5.75	0.00	0.00	73.00	62.00
9	0.00	0.00	0.00	0.00	0.00	0.50	0.00	0.00	0.00	1.50	40.00
10	1.00	0.00	2.50	3.00	7.75	5.50	13.00	7.50	0.00	38.25	86.00
11	5.00	10.75	2.75	19.50	13.25	2.50	11.50	4.25	0.00	59.50	80.00
12	33.00	15.75	28.75	14.50	13.75	19.50	56.75	36.00	0.00	218.00	351.00
13	0.00	1.00	0.00	3.25	0.00	11.00	37.25	4.00	0.00	56.50	1.00
14	0.00	0.00	0.00	0.00	0.00	0.00	0.00	2.50	0.00	2.50	1.00
15	1.75	4.50	0.75	4.50	0.75	12.50	1.50	2.75	0.00	29.00	15.00
16	12.00	0.00	3.50	3.00	3.75	3.00	2.50	2.00	0.00	29.75	14.00
17	163.50	157.75	151.50	174.00	163.75	155.50	157.75	175.75	0.00	1299.50	2341.00
18											

Figure 1-2: Marking example over an image of a spreadsheet

CONTROLLERS/MARKERS OVERVIEW

This section introduces you to the most common devices you might use with the CR-100. The CR-100 supports up to two RS-232 devices and up to 10 USB devices through the addition of powered USB hubs.

IMPORTANT: Be sure to power down the Pointmaker before connecting or disconnecting any controllers. The Pointmaker automatically detects installed controllers upon power up.

DTU-30 Digitizing Tablet

The *Pointmaker DTU-CTL470 Digitizing Tablet* is optional for the **CR-100** (tablet design may vary). In general, the tablet is used to draw, position pointers or make menu selections. The position and movements of the stylus (also called a pen) are represented by a video pointer on whatever display devices are activated. Additionally, most setup commands can be activated using the tablet rather than entering the on-screen menu system (*see Using the CR-100 Menu System, on page 27.*)

Refer back to this section, if needed, for general instructions concerning the tablet's operation.



Tablet colors vary.

Figure 1-3: DTU-CTL470 Digitizing Tablet Overview

ACTIVE AREA

The maximum area on the Pointmaker digitizing tablet that responds to the stylus. This area includes the Menu Strip, as well as the Tracking Area.

TRACKING AREA

The drawing/pointing region within the tablet's Active Area. The Tracking Area corresponds to the screen area on the monitor or display.

MENU STRIP

The icons (or buttons) at the top of the Active Area that you click to select pointer or line style, erase or clear markers, change marker colors, or change to another marker overlay.

TIP BUTTON

The Tip Button of the stylus is a select button, like the left button of a mouse. Use the Tip Button to draw or position markers. Clicking the Tip Button on a tablet icon activates that icon's function. You also use this button in combination with the Barrel Button to access the menu system.

BARREL BUTTON

Use the Barrel Button like the right button of a mouse. It is a rocker button and works the same way on either end. You primarily use this button to anchor markers. You also use this button in combination with the Tip Button to access the menu system. The two buttons must be pressed for at least 5 seconds.

Marker and Cursor Movement

Unlike a mouse controller, a tablet allows you to make drawings and place pointers with absolute positioning (mouse devices and keyboards use relative positioning). Absolute positioning means that the position of the stylus on the tablet surface corresponds directly to the position on the screen. For example, if you place the stylus in the lower-left corner of the tablet Tracking Area, the active pointer will move to the lower-left corner of the screen. Absolute positioning may take a few moments to adjust to if you've never used a tablet.

KB-30 Keyboard

With the keyboard, you can select, type, position, save, and erase the markers on the overlay. You also use the keyboard to access the menu system and change the appearance of markers. The following are general definitions for keyboard functions.

More details on each key's functions can be found in the Appendix (*see Activating the Menu, on page 27*).

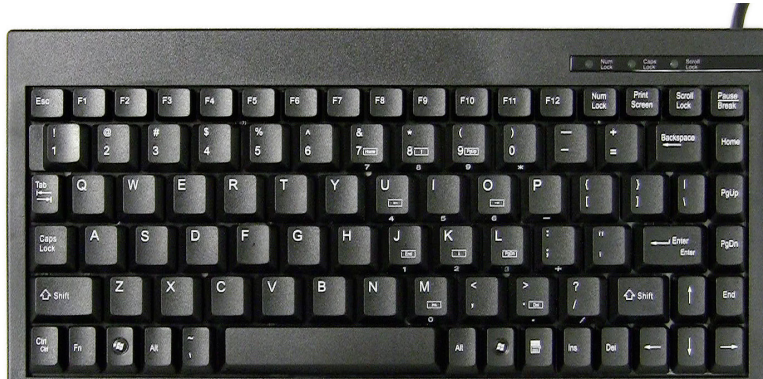

Figure 1-4: Pointmaker KB-30 Keyboard Controller

Keyboard Controller Functions

The keyboard functions can be divided into two categories: Marking Keys and Action Keys.

Marking keys display markers or affect their appearance, such as Frames and Frame Sizing

Action Keys control operations of the unit, such as changing to a different marker overlay or switching to a different video source.

Marker and Cursor Movement

When operating the Pointmaker with the keyboard controller, you can position active markers using the arrow keys (referred to as Positioning Keys). These keys are located to the right of the Enter key. For fine movement, press the Ctrl key along with one of the Positioning keys.

You can also use Positioning keys to size frames before they are anchored. For fine sizing, press the Ctrl key along with one of the positioning keys.

Within menus, you can move cursors among the options by using the Positioning keys.

Touch Screens and Whiteboards

The Pointmaker CR-100 is engineered for use with many touch screens or interactive whiteboards sold by other manufacturers. Contact Pointmaker LLC for compatibility information.

In general, you use the touch screen to draw, position pointers, or make menu selections. The broad definition of the areas (or zones) on the touch screen are listed below.

Calibrating the touch screen enhances the intuitive feel of drawing on the display. It's essential to do a rough calibration the first time you start the unit after connecting the touch screen. This gives you enough control to activate the menu and do a complete calibration. *(See Calibrating CR-100 Controllers, on page 47.)*

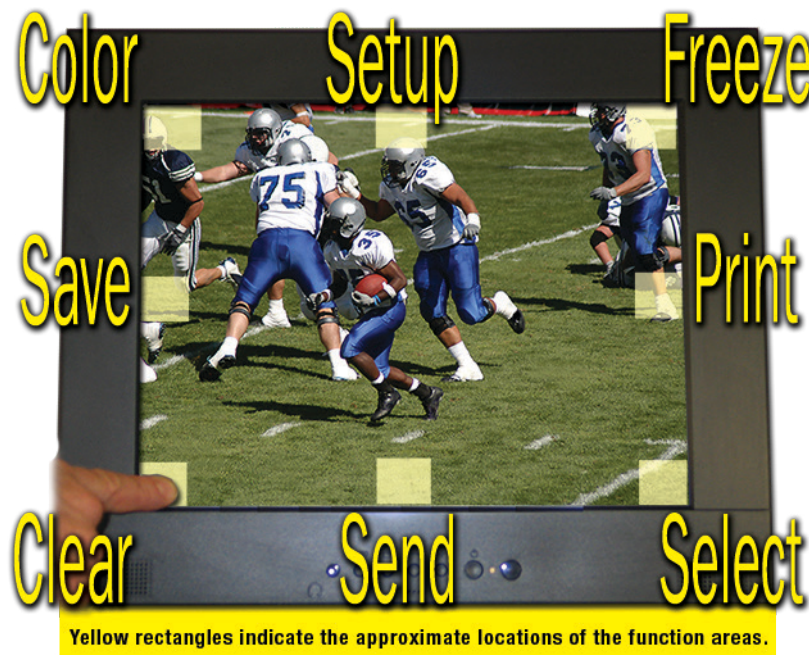

Figure 1-5: Pointmaker Touch Screen Function Area

TRACKING AREA

The area on the touch screen that responds to the movements of your finger. Draw and point in this area.

FUNCTION AREAS

The eight regions on the touch screen that, when tapped, activate a function. If you are drawing and move across one of these areas, the function is not activated.

Details on touch screen functions can be found in the Appendix (*see Quick Reference for Touch Screens and Whiteboards, on page 144*).

Marker and Cursor Movement

When operating the Pointmaker with a touch screen, you position pointers anytime you tap the screen. You cannot reposition an anchored pointer; however, you can clear or erase a pointer and begin again.

Mouse Devices

There are numerous other compatible devices for use with the CR-100. They are mostly based on PC-compatible mouse controllers with two buttons. Since Pointmaker LLC does not manufacture these devices, you will need to test the compatibility of any particular unit. For details on mouse functions, refer to the Appendix. (*See Calibrating CR-100 Controllers, on page 47*).

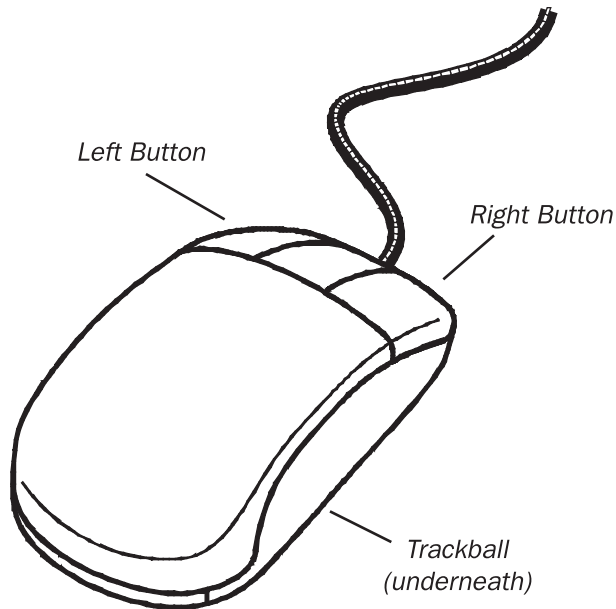

Figure 1-6: Mouse Device

TRACK BALL

Moves the cursor or active pointer anywhere on the screen according to how the ball is rolled.

LEFT BUTTON OR FIRST BUTTON

The Left Button on a mouse allows you to draw when pressed, or anchor a pointer when clicked. The Left Button is used in combination with the Right Button to access the menu system and change marker color.

RIGHT BUTTON OR SECOND BUTTON

The Right Button on a mouse allows you to undo or clear a marker. The Right Button is used in combination with the Left Button to access the menu system and change marker color.

Marker and Cursor Movement

When operating the Pointmaker with a mouse device, you can move the cursor or active pointer anywhere on the screen by moving the mouse's track ball. The active pointer or cursor will move respectively.

SECTION TWO:
INSTALLATION

GENERAL INSTALLATION

Installation of the Pointmaker CR-100 can be divided into the following four areas:

- **Connect Video Sources and Outputs**
- **Connect Controllers**
- **Connect LAN**
- **Power Up (leaving the CR-100 to last)**

Connecting the Video Source and Outputs

HDMI Connectors

To connect HDMI video:

1. **HDMI Input:** Using a HDMI video cable, connect the Pointmaker HDMI INPUT connector to a HDMI output connector on a HDMI video source.



Figure 2-1: HDMI Video Connectors

2. **HDMI output:** Using a HDMI video cable, connect the Pointmaker HDMI OUTPUT connector to a HDMI output connector on a HDMI video source.

HDMI IN and HDMI OUT are HDCP compliant.

DVI-D Connectors (through HDMI)

1. If desired, use a HDMI to DVI-D video cable to connect the Pointmaker HDMI INPUT or OUTPUT connector to a DVI display device.

Connecting Controllers

1. The following categories of controllers can be used with the CR-100:

- KB-30 Keyboard
- DTU-CTL470 Digitizing Tablets
- Touch Screens/Electronic Whiteboards
- Mouse devices
- iPads

Here are some guidelines for setting up these devices.

IMPORTANT: Be sure to power down the Pointmaker before connecting or disconnecting any controllers. The Pointmaker will automatically detect the installed controllers upon power up. If you change controllers or add a new controller, you need to power down, install the new controller(s), then power up.



Figure 2-2: Controller Ports

Connecting a 3rd Party Controller - COMM Port Wiring Issues

Customers sometimes encounter issues with the wiring of controllers other than those offered by Pointmaker LLC. The following information may be helpful in solving them.

- Pointmaker COMM ports sometimes use pin 9 to supply power to the DTX-DRV RS-232 line drivers. The DTX-DRV drivers support cable extensions for digitizing tablets or touch screens. Pin 9 was selected because its specification is seldom used. If you are connecting a device other than a DTX-DRV driver to a COMM port, the voltage may cause unexpected issues with the device.

- **COMM 1 and COMM 2 have jumpers for power on pin 9, and are set to OFF when shipped from the factory. If you require power for a DTX-DRV driver for either or both of these COMM ports, please contact technical support.**
- **Some touch screens may need hardware handshaking. In that case, try a cable with pins 7 and 8 tied together.**

Connecting the Keyboard, Tablet or other USB Devices

1. **Connect the device(s) to any USB port on the Point maker.**

The system supports up to 4 USB 3.0 devices and 1 USB B device.

Connecting Touch Screens and Electronic Whiteboards

The Pointmaker is compatible with many types of touch screens (**call Pointmaker LLC for compatibility**). During these procedures, you may want to refer to the illustrations of the CR-100 back panel.

Pre-Installation Recommendations:

Cabling:

If you desire to have the touch screen farther from the CR-100 than the length of the touch screen's RS-232 cable, you may need to install a line driver. The touch screen and Pointmaker will not function properly if the signal strength is too weak or encounters interference. While the RS-232 specification indicates usage up to 50 feet, the actual distance at which the signal must be amplified will vary based upon environmental factors. Pointmaker LLC recommends that you test any configuration to determine whether the line drivers are needed.

FOR RS-232 Touch Screens:

You may install your own extension cable according to the following specifications:

- Three conductor cable

- Male DB-9 to female DB-9 wired straight through on pins 2, 3, and 5.

If you determine that you need a line driver to maintain signal strength, you may purchase the DTX-DRV line driver from Pointmaker LLC (see “*If installing the optional DTX-DRV extension*” on page 22). The DTX-DRV specification allows for distances up to 450 feet.

For USB Touch Screens:

Pointmaker LLC offers a USB line driver and extension hardware. Many third party line drivers are also available (**call Pointmaker LLC for compatibility**).

NOTE: Make all connections before applying power.

1. **Make video connections as indicated earlier in this section, and install the touch screen to the monitor as directed by your touch screen manufacturer. (See Connecting the Video Source and Outputs, on page 17.)**
2. **Connect a USB cable and extension to the USB port on the Pointmaker.**

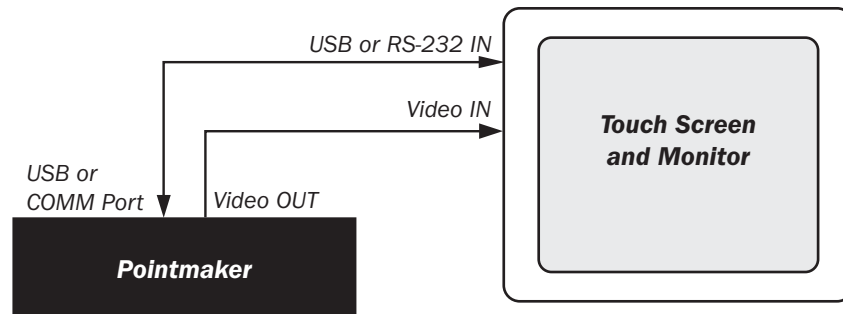

Figure 2-2: Touch screen hook-up overview

NOTE: Be sure to calibrate the touch screen on start up (see *Calibrating CR-100 Controllers*, on page 47).

If installing the optional DTX-DRV extensions:

1. **Connect the female DB-9 connector to the male DB-9 connector on the DTX-DRV extension transmitter from the touch screen cable (male microdriver).**
2. **Using an Unshielded Twisted Pair (UTP) cable with RJ-11 connectors, connect the male microdriver to the female microdriver.**

3. **Connect the DTX-DRV extension receiver (female microdriver) to a COMM port on the back of the CR-100.**

Connecting a Mouse Device

1. **Connect the mouse device to a COMM port on the back of the Pointmaker.**

If you add a controller at a later time, be sure to power down the Pointmaker, install the new device, then power up.

Videoconferencing

The CR-100 supports videoconferencing (*see Multipoint, on page 64*).

Power Up

These are the procedures for powering up.

1. **Plug the power cord into the back of the Pointmaker and then into any grounded outlet.**
2. **Plug the power cords from any video source(s), controller(s), and display(s) into any grounded outlet.**
3. **Turn on each of the connected units, and then press the power button on the front panel of the Pointmaker.**

NOTE: In order for the Pointmaker to properly sync with the video signals, the sources should be turned on first.

After a moment, a Pointmaker splash screen will appear, followed by the initializing of the ports, and ending with a copyright message.

After the startup process, a marker overlay will appear, displaying any previously created markers.

If this process is different for you, recheck your installation and power up again. Call Pointmaker LLC for support at (800) 552-2262 or (520) 745-0001 if it is still unsuccessful.

NOTE: To bypass port initialization, press ESC during startup.

SECTION THREE:
CR-100 MENU SYSTEM

OVERVIEW

This chapter covers the menu system built into the CR-100. It includes many settings you may want to make before a presentation. In general, they are made from the menu system, although some control devices can also access a few of the settings directly.

USING THE CR-100 MENU SYSTEM

This section describes how to access the menu system and make selections from it.

Default User Settings

1. **First, make your selections for the settings you wish to save.**
2. **Re-boot the unit using the CTRL-ALT-DEL key command or cycle the power with the power switch.**
3. **When you see the Copyright screen during the boot process, press CTRL-ALT-ENTER(on the number pad) to save your personal defaults.**

The screen will acknowledge that the settings have been saved.

4. **The settings can be recalled at any time by pressing CTRL-ALT-PgDn (on the number pad).**

Menu Basics

If the keyboard is installed, it is the only way you can enter the menu system. If the keyboard is not installed, you can access the menu system from one of the other control devices. NOTE: Using the CR-100 with the PVI Control iPad app does allow you to access the menu system while the keyboard is installed.

Activating the Menu

Keyboard: Press Setup Menu[Print Screen] key.

Digitizing Tablet: With the tip in proximity to the tablet, press and hold the Barrel Button, then press the Tip Button into the drawing area. Keep both pressed for at least 5 seconds.

NOTE: Press the tip button soon after the barrel button, or the CR-100 may interpret the barrel button press as a “clear” command.

Touch Screen (or Whiteboard): Tap upper center function area or whatever function area you assign (works only if no keyboard is connected).

Mouse Device: Press Right (Second) Button, then Left (First) Button, press both together for about 10 seconds (works only if no keyboard is connected).



Figure 3-1: Main Menu with Annotation highlighted

The Main Menu appears over the video image.

Menu Conventions

Once the menu system is displayed, you can make selections from it to navigate to the option(s) you wish to change. Each menu selection has the appearance of a rounded-corner button.

Not Selected

If a button is not selected, it has a gray background.

Selected

When a button is selected, it changes to a white background.

Hovering

As you move the selection arrow over a button (called “hovering”), it will either display a red shadow behind the button text (a Main Menu button), or turn the text in the menu from blue to red (a submenu button).

Submenus

A selection from the Main Menu causes a submenu to appear alongside it. A selection from the submenu sometimes displays a second submenu of choices based on the selection you make.

Outline Format

The entire menu system is an outline format that allows you to “drill down” to the specific option you wish to change. Whenever the Main Menu is visible, you can select directly from it to activate a different branch of submenus.

Making menu selections

Digitizing Tablet: Move pen tip lightly across the active area of the tablet until your selection is highlighted. Push the tip in until it clicks

Keyboard: Use arrow to move to your selection and press the Enter key.

Touch Screen (or Whiteboard): Tap the screen over the option you want to select.

Mouse Devices: Click Left Button on your selection. your selection is highlighted. Push the tip in until it clicks

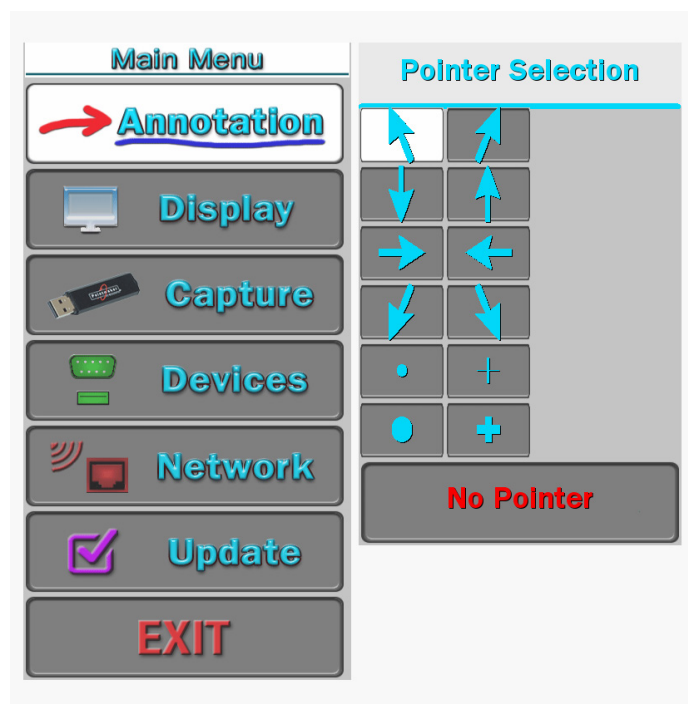

Figure 3-2: Sample Submenu

Exiting Menus

Exit a submenu by selecting any option in the Main Menu. Exit the menu system by selecting EXIT.

PREPARING THE CR-100 FOR USE

This section covers the menu system functions that are usually set before making a presentation. Once set, the CR-100 will save them in memory, even when powered down. Some of the functions can also be accessed directly through the keyboard or digitizing tablet.

The options include:

- **Customizing the Color Palette**
- **Setting a Brightness Level**
- **Changing Pen Proximity**
- **Selecting Video Sources**
- **Calibrating CR-100 Controllers**
- **Serial Port Settings**
- **Setting the Tablet Template**
- **Setting Date and Time**

The options commonly used during a presentation are covered in the chapter on markers (*see page 67*).

Customizing the Color Palette

During a presentation, all controllers (other than the digitizing tablet) allow you to select a marking color by cycling through each of the seven available colors. To streamline color selection, the Color Palette allows you to pre-select which of the CR-100's seven marking colors you wish to use during a presentation. It also makes it easy to select colors that work well with the images you are presenting. When the Color Palette command is activated, the seven colors appear over whatever video input signal is currently selected. This allows you to see how well the colors contrast with the image.

NOTE: Color choices made using the digitizing tablet override any settings made in the Color Palette Menu.

Selecting Colors for a Presentation

1. **Activate the menu system** (*see Activating the Menu, on page 29*).

The Main Menu appears (see Figure 3-1: Main Menu, on page 30).

2. Select ANNOTATION

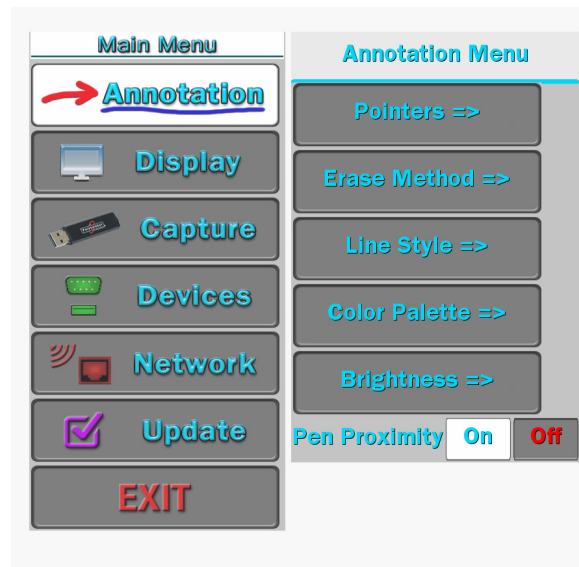

Figure 3-3: Annotation Menu

The Annotation Menu appears.

3. Select COLOR PALETTE.

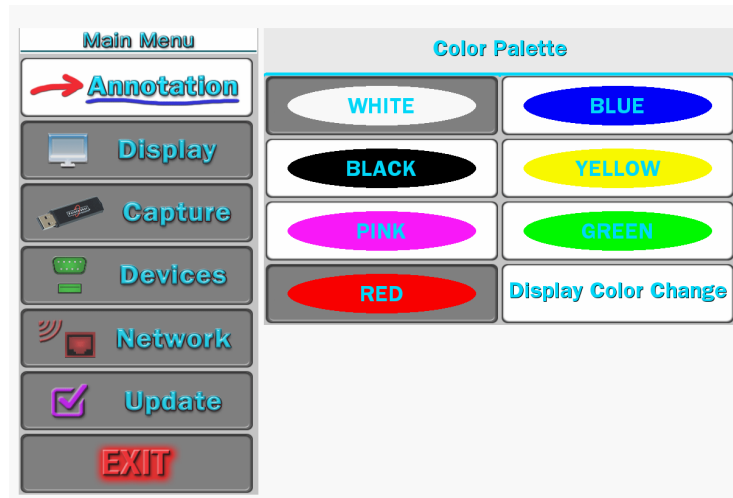

Figure 3-4: Color Palette with all colors selected except white and red.

The Color Palette Menu next to the Main Menu.

4. Select the color or colors that you would like to have available during the presentation.

NOTE: These selections toggle on and off. Selected colors are surrounded by a solid white fill.

You must select a minimum of one color. If you select only one color, you will not be able to deselect until you select a second color.

5. **Activate or disable the DISPLAY COLOR CHANGE option.**

If Activated: During presentations, a small block of color appears briefly in the lower-right of your display each time you activate the Change Color command (see *Assigning Marker Colors, on page 71*). Normally, the active pointer will indicate the current color, but if the pointer is off, another indicator is needed to show you which color is current. The small color block serves this purpose.

NOTE: When enabled, this option will be surrounded by a white fill.

If Disabled: No color block will appear when the Change Color command is activated. Broadcasters and certain other presenters may desire this setting.

NOTE: The digitizing tablet's commands are not affected by this setting because the template's color icons let you directly select the active color.

6. **Exit the Color Palette Menu.**

Selecting a Brightness Level

You can select a brightness level for all markers on an overlay. This adjustment aids in creating optimum contrast between CR-100 graphics and the video image. The brightness selection is only applied to the current overlay, so it is possible to display a different brightness level for each of the overlays.

Brightness is best controlled from the keyboard, but you can also adjust brightness with other devices using the menu system or the tablet template. Keyboard and tablet settings override any settings made in the menu system.

Be sure to display the overlay first so you can see the effects of the change.

From the Tablet

Activate the Brightness Command by pressing the tip button on the Brightness scale.

Selections to the left decrease brightness, while selections to the right increase brightness.

From the Keyboard

1. **Repeatedly activate the Change Brightness command until the markers display the desired brightness level.**

(see Activating the Menu, on page 29)

NOTE: You can move backwards through the brightness levels by activating the reverse toggle command.

2. **Exit the Brightness mode by selecting any other function.**

From the Menu System

1. **Activate the menu system** *(see Activating the Menu, on page 27).*

The Main Menu appears *(see Figure 3-1: Main Menu, on page 28).*

2. **Select ANNOTATION**

The Annotation Menu appears *(see Figure 3-3: Annotation Menu, on page 32).*

3. **Select BRIGHTNESS.**

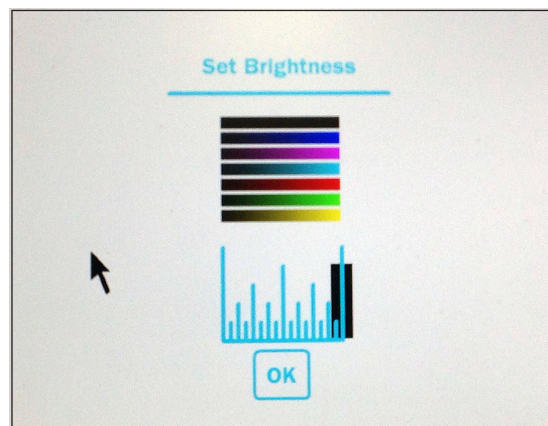

Figure 3-5: Set Brightness Dialog

The Set Brightness dialog appears in place of the Main Menu, featuring a transparent background that allows you to adjust brightness in accordance with your image.

4. **Select the level of brightness you desire.**

NOTE: Moving the indicator to the left will decrease brightness of Point-maker markers and menus. Moving the indicator to the right will increase brightness. If the brightness is set too high for the display, the markers will smear across the image.

5. **Exit the dialog by activating the OK button.**

Changing Pen Proximity

The CR-100 with optional digitizing tablet may have Pen Proximity on or off. When Pen Proximity is enabled, the active pointer disappears as you move the pen tip away from the tablet. When Pen Proximity is disabled, the active pointer remains on-screen even when you pull the pen away from the tablet or monitor. You must have turned the active pointer on for this feature to work.

You can change Pen Proximity from the tablet (Broadcaster template only), or from the menu system. Factory setting is Off.

From the Menu System

1. **Activate the menu system** (see *Activating the Menu*, on page 27).

The Main Menu appears (see *Figure 3-1: Main Menu*, on page 28).

2. **Select ANNOTATION.**

The Annotation Menu appears (see *Figure 3-3: Annotation Menu*, on page 32).

3. **Select PEN PROXIMITY.**

The colored fill in the PEN PROXIMITY box indicates the new status. The white fill means that pen proximity is enabled.

4. **Exit the menu system.**

You can now point and draw using the new PEN PROXIMITY setting.

The CR-100 gives you a wide range of video parameters for fine tuning your video output.

Setting Video Output

The CR-100 gives you a wide range of video parameters for fine tuning your video output.

1. **Activate the menu system** (see *Activating the Menu*, on page 27).

The Main Menu appears (see *Figure 3-1: Main Menu*, on page 28).

2. **Select DISPLAY.**

The Display menu appears.

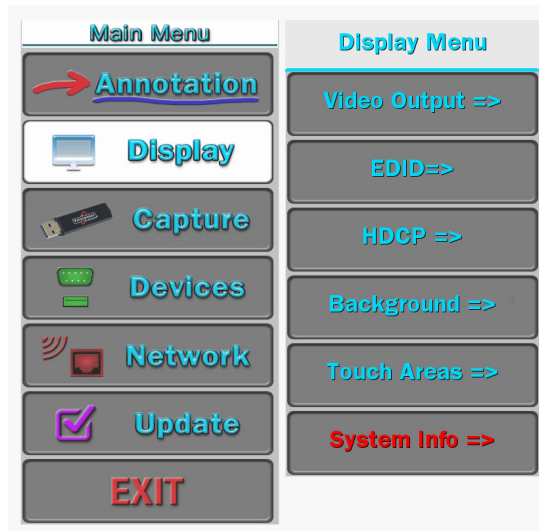

Figure 3-6: Display Menu

3. **Select VIDEO OUTPUT.**

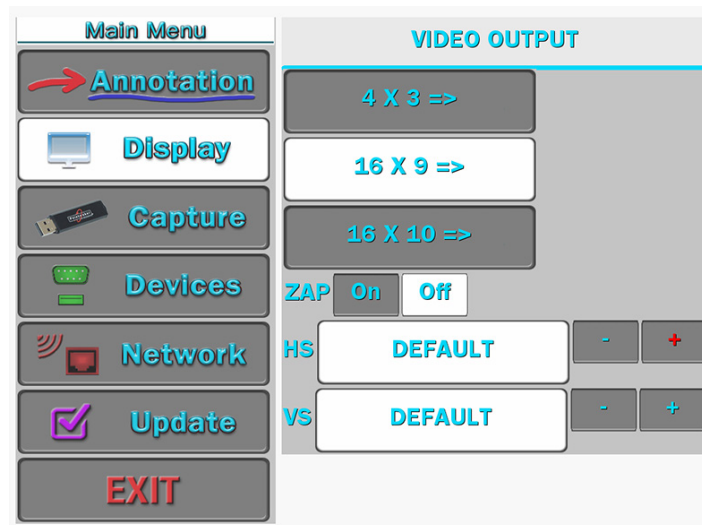

Figure 3-7: Video Output Menu

The Video Output dialog appears next to the Main Menu.

4. Selecting an output ratio.

The associated Video Output Formats dialog appears next to the Main Menu.

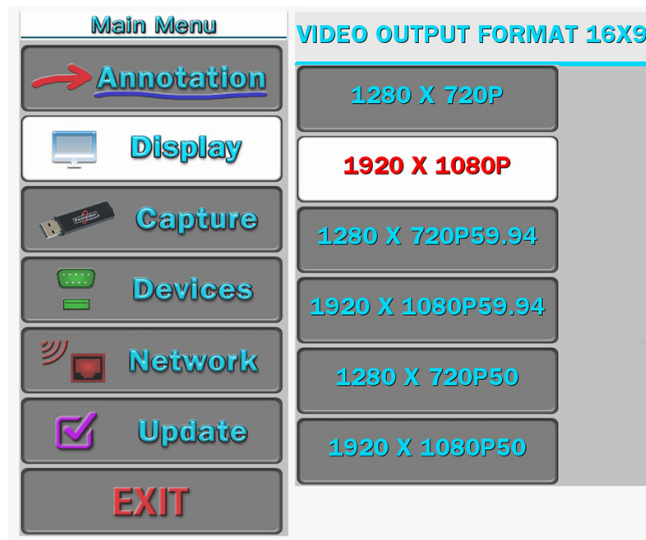

Figure 3-8: Video Output Formats Dialog for 16 x 9 Ratio

5. Select a format.

The CR-100 will immediately switch to output format selected.

6. Exit the menu system.

Zap Icon Toggle

This toggle switch allows display of a “zap” icon in the lower right-hand corner of the screen as a way of being able to tell if the marking layer is active or hidden. If no marks have been drawn, there is no other visual way of knowing if the layer is active or not. The zap icon is visible when the layer is active.

1. Activate the menu system (see *Activating the Menu*, on page 27).

The Main Menu appears (see *Figure 3-1: Main Menu*, on page 28).

2. Select DISPLAY.

The Display menu appears beside the Main Menu (see *Figure 3-6: Display Menu, on page 36*).

3. Select VIDEO OUTPUT.

The Video Output dialog appears (see *Figure 3-7: Video Output dialog, on page 36*).

4. Set the Zap option on or off.

When it is on, the Zap icon  shows at the bottom-right of the screen. This option is used, usually in complicated video configurations, to verify that the video stream being viewed includes the CR-100.

5. Exit the menu system.

EDID

This dialog allows you to set the Pointmaker's preferred EDID resolution, in effect, telling the video source what resolution to send.

1. Activate the menu system (see *Activating the Menu, on page 27*).

The Main Menu appears (see *Figure 3-1: Main Menu, on page 28*).

2. Select DISPLAY.

The Display menu appears (see *Figure 3-6: Display Menu, on page 36*).

3. Select EDID.

The EDID menu appears.

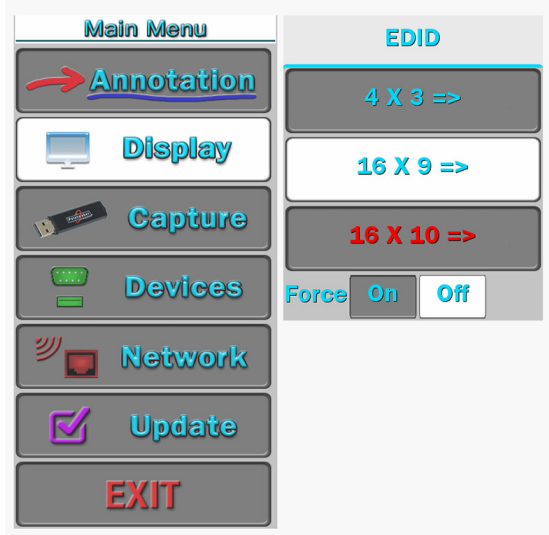

Figure 3-9: EDID Menu

4. Turn FORCE On or Off.

When Off, the CR-100 defaults to 1080p. When On, the CR-100 changes to the resolution you select.

5. Select an EDID format

The associated EDID Format submenu appears.

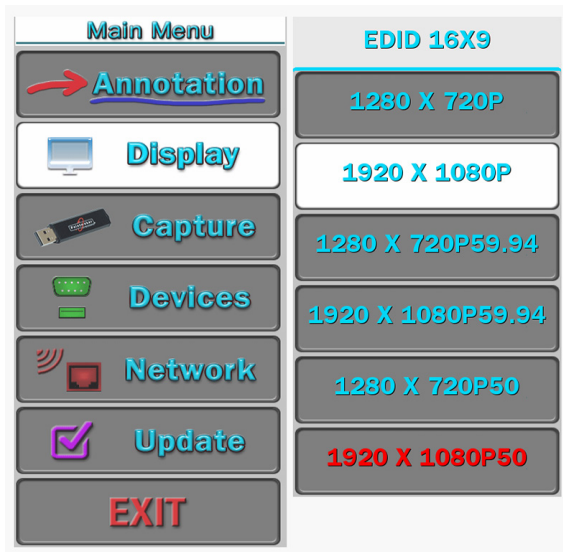

Figure 3-10: EDID 16 x9 Submenu

6. **Select a resolution.**
7. **Exit the menu system.**

HDCP Input/Output

This dialog allows you to turn HDCP on or off for the HDMI input and output.

1. **Activate the menu system** (see *Activating the Menu*, on page 27).

The Main Menu appears (see *Figure 3-1: Main Menu*, on page 28).

2. **Select DISPLAY.**

The Display menu appears (see *Figure 3-6: Display Menu*, on page 36).

3. **Select HDCP.**

The HDCP dialog appears.

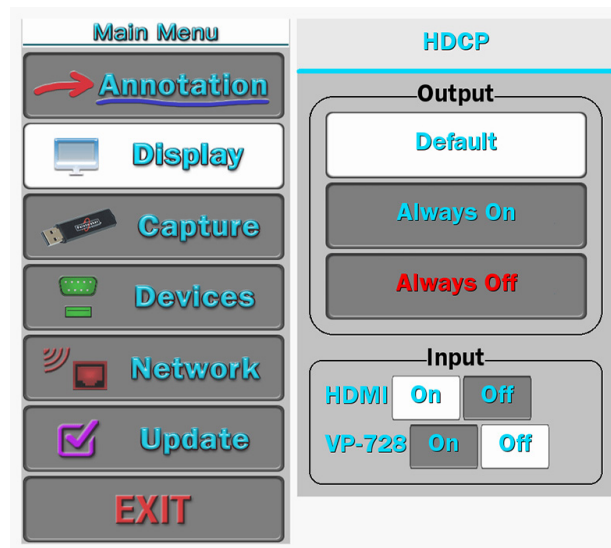

Figure 3-11: HDCP dialog.

4. **Select to leave HDCP Output Always On, Always off or Default.**

If you want output HDCP to follow input HDCP, set the HDCP Output to Default and select the HDMI Input to Off.

5. **Exit the menu system.**

Background Options

The Background menu allows you to select between your current Source Video or the Chalkboard background. It also has an Auto Chalkboard selection which causes the CR-100 to automatically switch to the Chalkboard if no video signal is present at the selected Source Video.

1. **Activate the menu system** (see *Activating the Menu*, on page 27).

The Main Menu appears (see *Figure 3-1: Main Menu*, on page 28).

2. **Select DISPLAY.**

The Display menu appears (see *Figure 3-6: Display Menu*, on page 36).

3. **Select the BACKGROUND option**

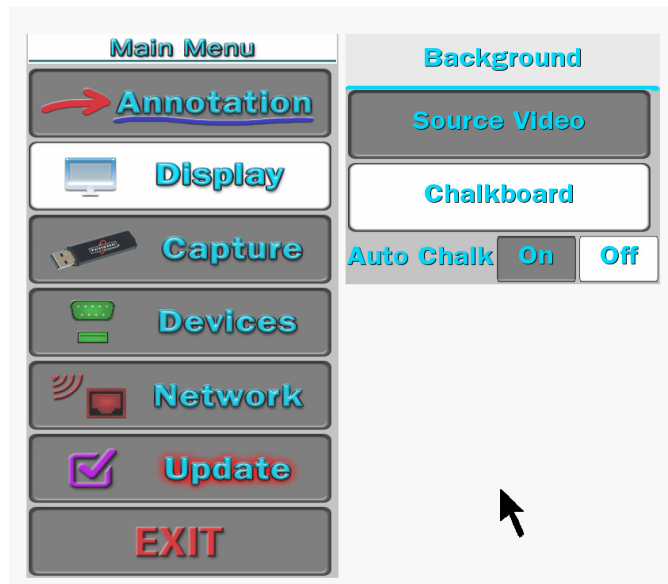

Figure 3-12: Background dialog

The Background dialog appears.

4. **Select the option(s) you desire.**

Switch between Source Video and Chalkboard .

Turn Auto Chalkboard on or off.

5. **Exit the menu system.**

Touch Screen Command Areas

This dialog allows you to assign touch screen commands to the various areas of your touch screen. Touching the screen in that area (after exiting the menu) will activate the command. Commands with the word “none” assigned are inactive. (see *Connecting Touch Screens and Electronic Whiteboards, on page 19*), also (see *Using the CR-100 Menu System, on page 27*).

Note that you can also turn off touch corner labels, or change their color to contrast with the video image.

1. **Activate the menu system** (see *Activating the Menu, on page 27*).

The Main Menu appears (see *Figure 3-1: Main Menu, on page 28*).

2. **Select DISPLAY.**

The Display menu appears (see *Figure 3-6: Display Menu, on page 39*).

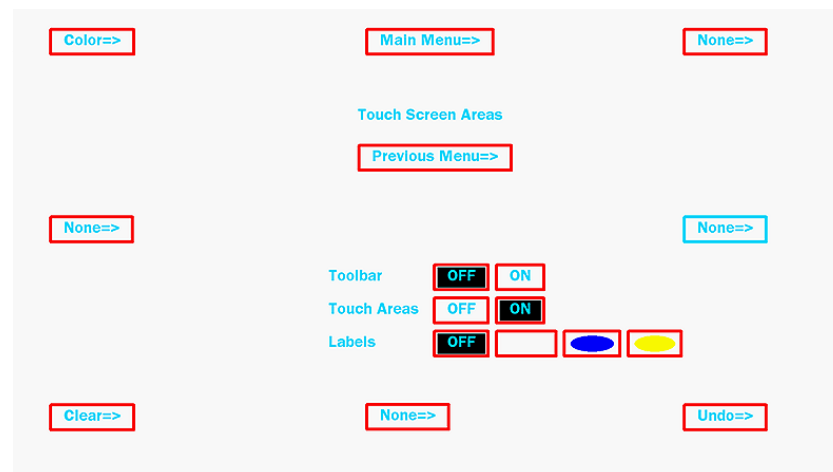

Figure 3-13: Touch Screen Corners dialog

The Touch Screen Corners dialog appears.

4. **Select one of the areas.**

Touch Screen Area Select	
None	Image Save
Clear	Image Send
Undo	Image Get
Color	Select
Freeze	Main Menu
Print	Next Video
Color Mode	Prev Video
Previous	Video Input

Figure 3-14: Touch Screen Area Select menu

The Touch Screen Area Select menu appears.

5. **Select the command you wish to assign.**

The menu disappears and the Touch Screen Corners dialog reappears.

6. **Repeat steps 4 and 5 until you are finished assigning touch screen command areas.**
7. **Select Previous Menu and then exit the menu system.**

System Info

This selection presents a readout of relevant information concerning your unit. This information can be useful in troubleshooting, especially if you are contacting Pointmaker support.

1. **Activate the menu system** (see *Activating the Menu*, on page 27).

The Main Menu appears (see *Figure 3-1: Main Menu*, on page 28).

2. **Select DISPLAY.**

The Display menu appears (see *Figure 3-6: Display Menu*, on page 36).

3. **Select SYSTEM INFO.**

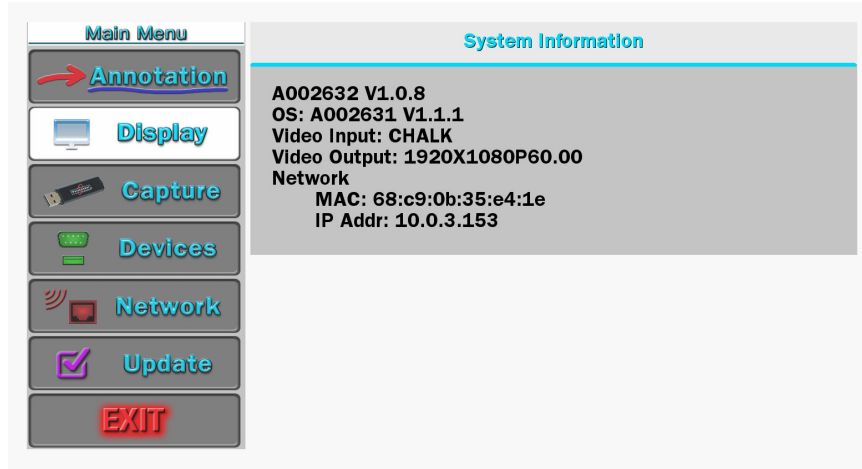

Figure 3-15: System Information

Capture Options

A captured frame or field can be saved to a USB memory device, to a computer running TFTP, or an SMB share. The File Defaults menu selection allows you to set the default settings for how the files are saved. It includes the directory, name and sequence numbering. This allows for fast saving with no dialog boxes involved. Files are saved in the bitmap format, 24 bit true color, 720x485, with the extension “.bmp”.

1. **Activate the menu system** (see *Activating the Menu*, on page 27).

The Main Menu appears (see *Figure 3-1: Main Menu*, on page 28).

2. **Select CAPTURE.**

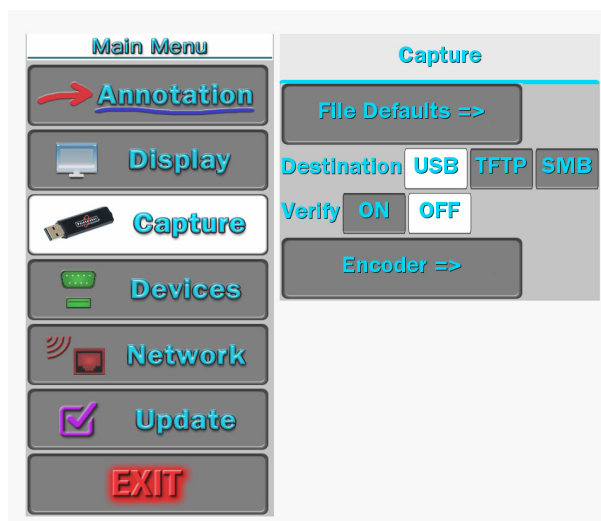

Figure 3-16: Capture dialog

The Capture dialog appears.

3. **Select FILE DEFAULTS.**

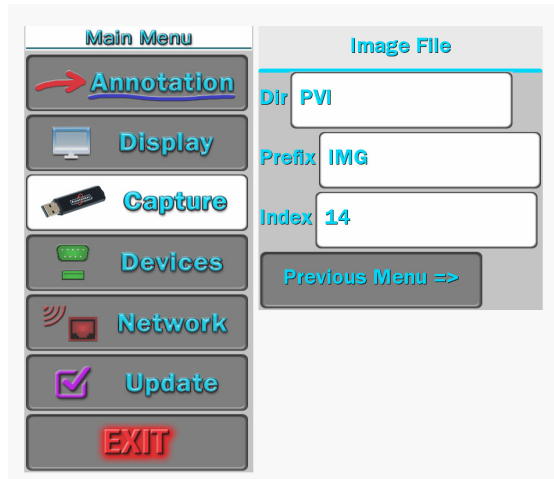

Figure 3-17: Image File Defaults dialog

The Image File Defaults dialog appears.

4. **In the DIR field, enter the directory name where you wish to save the file.**

It must be 8 alphanumeric characters or less, no spaces and no subdirectories. The default is PVI.

5. **In the PREFIX field, enter whatever letters you want each filename to begin with.**

The prefix must be 5 alphanumeric characters or less, no spaces. The default is IMG.

6. **In the INDEX field, enter the number to start numbering from.**

Each time an image is saved, the number will increment. The default is 1. The numbering is remembered by the CR-100, even through cycling of power.

Given the example shown, filenames will start with img1.bmp, then increment to img2.bmp, img3.bmp and so on.

7. **Exit the dialog by selecting the Previous Menu button.**

8. **Exit the menu system.**

Setting the Destination for Saved Files

After setting up the file defaults for saving images, you will want to select the destination for your saved files. Files can be saved to USB memory devices, a computer using TFTP, or an SMB share.

1. **Activate the menu system** (see *Activating the Menu*, on page 27).

The Main Menu appears (see *Figure 3-1: Main Menu*, on page 28).

2. **Select CAPTURE.**

The Capture dialog appears (see *Figure 3-16: Capture dialog*, on page 44).

3. **Select the Destination as USB, TFTP or SMB.**

The CR-100 will use your selection whenever you activate the Save command from either the digitizing tablet or the touch screen.

4. **Exit the menu system.**

Setting the Verify Option

In circumstances where it is important to know that a file has been successfully saved or printed, this setting allows you to verify the end result. If you turn Verify on, a dialog will appear after each save or print command, asking you to verify that the image was successfully saved or printed.

1. **Activate the menu system** (see *Activating the Menu*, on page 27).

The Main Menu appears (see *Figure 3-1: Main Menu*, on page 28).

2. **Select CAPTURE.**

The Capture dialog appears (see *Figure 3-16: Capture dialog*, on page 44).

3. **Set Verify ON or OFF.**

4. **Exit the menu system.**

Calibrating CR-100 Controllers

You need to calibrate the touch screen on first installation. Calibration ensures an intuitive and precise feel to drawing and marking over the particular monitor you are using.

NOTE: The calibration described in this section is the most accurate calibration for each touch screen connected to the CR-100. However, it is usually necessary upon first power-up to do a rough calibration during the start-up process. You can access this calibration through a short cut by touching the copyright screen when it appears. The unit will activate the Touch Screen Calibration dialog, with instructions for calibrating. This calibration is accurate enough to operate the unit. You should then do the following calibration procedure to obtain the most accurate calibration.

Calibrations are automatically saved for each video port. If you move a touch screen to a different port, run the calibration again. Or, if you have a touch screen display with multiple video inputs, you should calibrate the touch screen for each input.

All calibrations are stored in battery backed-up memory. The most recent calibration will be recalled any time power is cycled off and on.

From the Menu System

1. **Activate the menu system** (see *Activating the Menu*, on page 27).

The Main Menu appears (see *Figure 3-1: Main Menu*, on page 28).

2. **Select DEVICES**

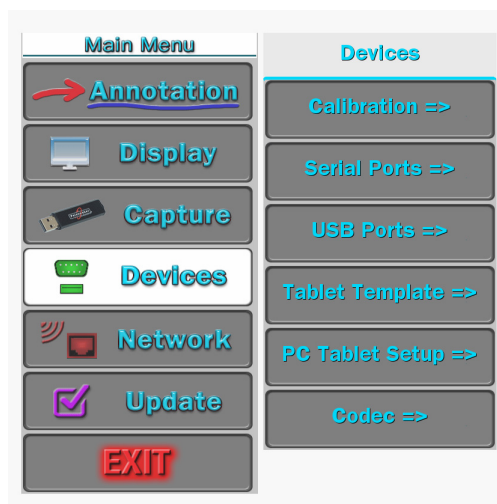

Figure 3-18: Devices menu

The Devices menu appears

3. **Select CALIBRATION.**

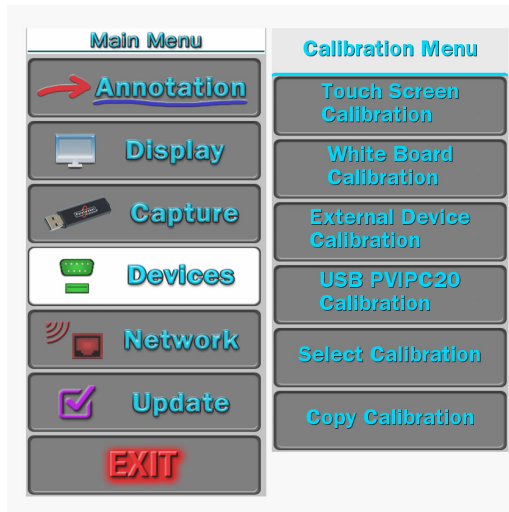

Figure 3-19: Calibration Menu

The Calibration Menu appears.

4. **In the Calibration Menu, select the controller you want to calibrate.**

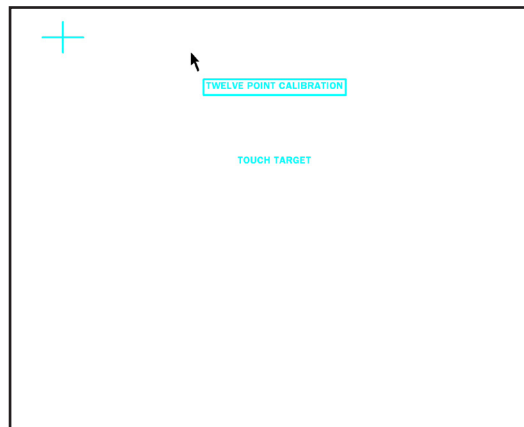

Figure 3-20: Calibrate Touch Screen Dialog

The Calibration dialog for the selected controller appears.

5. **Follow the calibration instructions displayed.**

After you perform final calibration procedures, the Calibration dialog automatically disappears, and you return to the menu system.

6. Exit the menu system.

Repeat this process for each video input on your touch screen display.

Storing (Copying) a Calibration

For each video output, the CR-100 has nine memory locations where calibrations can be stored for later recall. They are numbered 1 through 9. Location 0(zero) is considered the default memory location, and stores whatever calibration was last done. If you anticipate changing calibrations on a frequent basis, storing your calibrations in locations 1-9 makes it easy to change the active calibration without 1) going through the calibration procedure, and 2) having to reboot the CR-100.

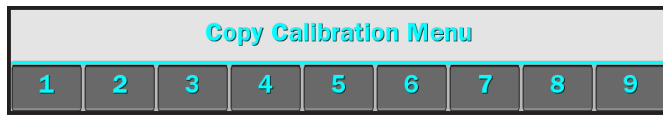

Figure 3-21: Copy Calibration Menu

To store a copy of the last manual calibration (stored in location 0) in whatever memory location you choose, select the Copy Calibration command from the Calibration Menu. Then, select the numbered button for your desired memory location. If there was a calibration previously stored in the location you select, it will be overwritten.

Note: You will probably want to make a written record of which calibrations you have stored in each location since the CR-100 keeps only the location number.

Select a Calibration

When you are ready to use a calibration you have previously stored, choose Select Calibration from the Calibration menu. Then, select the numbered button for the memory location you desire. The calibration stored in that location becomes the active calibration.

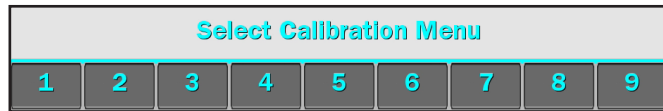

Figure 3-22: Select Calibration dialog

Serial Port Settings

Serial ports are used for two main purposes: 1) connecting controller/marker devices 2) connecting to other systems (videoconferencing, remote control, a second Pointmaker, a PC). This section explains the options available to you for each purpose.

The Serial Port dialog also allows you to assign a priority system to control users if multiple controller/markers are connected.

Configuring Serial Device Types

Initialization of Device Types

Serial ports are “initialized” when the CR-100 is powered on. During this process, the CR-100 attempts to determine what device type(controller/marker) is connected to each port. This procedure can be lengthy since the CR-100 accommodates a wide range of devices, and in its default detection mode (autodetect), it will run through the entire list of possibilities for each port. Using the settings available in the Serial Ports menu, it is possible for you to limit the initialization process for a designated port so that the CR-100 looks for only the device type you specify. This speeds up the initialization process considerably.

Integrating the CR-100 with Other Systems

Since only controller/marker device types are able to be recognized during the initialization process, all other devices must be set up manually. The CR-100 allows you to manually adjust communication settings for either of its ports (*see Setting Comm Port Parameters, on page 54*). This allows the CR-100 to be integrated with:

- 1) an A/V system as a remote control command station where it can both control A/V devices and mark over any images presented;
- 2) a remote control system which can send commands to the CR-100, controlling its various functions, like AMX/Crestron.

Cisco Codec

The CR-100 supports the Cisco Codec through either of the serial ports. Connect the two units using a straight-through serial cable, making note of which serial port you use. When you get to the instructions for selecting the device type, choose either “Codec” or “Cisco Codec”.

Designating a Serial Device Type

1. **Activate the menu system** (see *Activating the Menu*, on page 27).

The Main Menu appears (see *Figure 3-1: Main Menu*, on page 28).

2. **Select DEVICES.**

The Devices menu appears (see *Figure 3-18: Devices menu*, on page 47).

3. **Select SERIAL PORTS.**

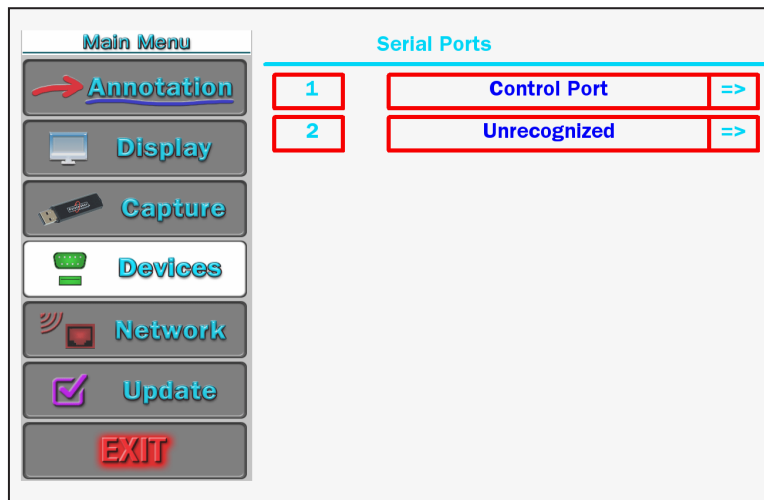

Figure 3-23: Serial Ports Dialog

The Serial Ports dialog appears.

NOTE: All the serial ports installed on your CR-100 are listed by port number, with the device type displayed to the right of each number. If the device type is in blue, it has been assigned through the autodetect procedure at startup.

4. **(optional) Select the device type you wish to have permanently assigned.**

If the device type can be permanently assigned (some types cannot), the color changes from blue to black. With the device permanently assigned, the next time the CR-100 is powered up, the autodetect procedure will skip this port. If the assigned device needs to be initialized at startup, it will be initialized according to the device type listed.

NOTE: If the device type listed for a port cannot be permanently assigned (for example: device type “unknown” or if you try to assign more than one port for use with other systems (see *Integrating the CR-100*

with *Other Systems*, on page 50), there are two ways to change it. The next two steps describe how.

5. (optional) Select the arrow to the right of the device type you wish to change.

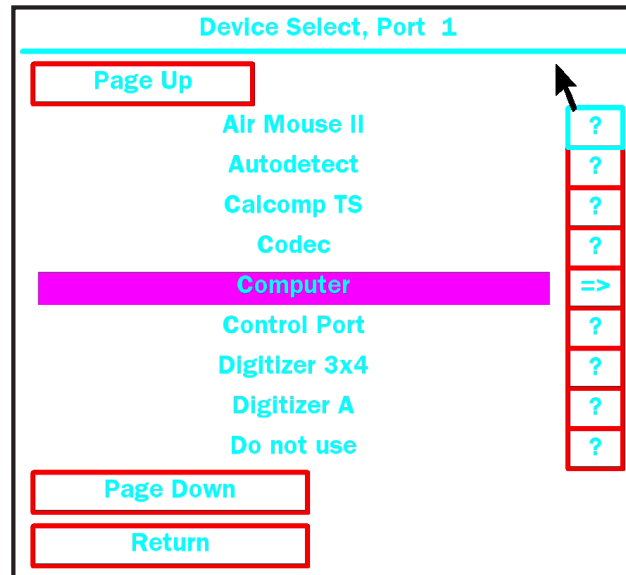

Figure 3-24: Device Select Dialog

The Device Select dialog appears.

This dialog presents a scrolling list of all device types currently supported by the CR-100 in alphabetical order. The Page Up and Page Down buttons allow you to quickly scroll through the names until you find the device type you desire. When you locate and select the name you wish to assign, it will move to the center of the list, where it will be highlighted. The new device type is now assigned.

Device types which cannot be selected are in white.

Only one of the two COMM ports may be set to Control Port. Either COMM port may be set to Control Port, but only one at a time may be assigned as Control Port.

When a “?” button is selected, a screen with further information about that device type will be displayed.

If a device type that is used for communicating with other systems is selected, an arrow button will replace its “?” button. Selecting that arrow button will activate the control port dialog (see *Figure 3-25: Control Port Dialog*, on page 54).

You can return to the Serial Ports dialog to make further changes by selecting the Return button, or by selecting Input Devices and then selecting Serial Ports.

NOTE: If you are designating a port for use with another system, you will need to set Comm Port parameters before exiting the menu system (see *Setting Comm Port Parameters on page 53*).

6. (optional) Select the device type name you wish to change.

When the device type name, instead of the arrow to its right, is activated, the device type will change without having to display the Device Select submenu. This method is only recommended for those with more extensive experience in assigning device types. Each time the name is selected, it causes a different device type to appear. The list of devices available using this method is an abbreviated version of the list in the Device Select dialog.

A click on the right side of the name moves forward one device. A click on the left side of the name moves backward one device. (If you are using the keyboard to select, it moves backward through the list only.) Keep clicking until the device type you desire is displayed. It will be assigned permanently when the CR-100 is rebooted.

NOTE: If you are designating a port for use with another system, you will need to set Comm Port parameters before exiting the menu system.

7. Exit the menu system and recycle the power on the CR-100.

NOTE: The CR-100 must either be rebooted for the new device type assignments to be made permanent or you can return to the Serial Ports dialog and select the red box next to the new assignment to activate the device immediately.

Setting Comm Port Parameters

If you are assigning a port for communicating with another system (see *Integrating the CR-100 with Other Systems, on page 50*), you must select either **Control Port** or **PVI to PVI** as your device type. The CR-100 supports assigning only one port for each type.

Control Port: Choose this option if the CR-100 is being used as an A/V remote control command station, if it is being controlled remotely using RS-232 commands, or if it is being connected to a PC.

PVI-to-PVI: Use this selection if the CR-100 is being used in a videoconferencing system.

1. **Select the appropriate device type in the Device Select dialog for the port where you are connecting the other system** (see Figure 3-24: Device Select Dialog, on page 52).

Where a question mark is usually found, you will instead see an arrow.

NOTE: If the device type you desire for connecting to other systems is unavailable, check to see if it is assigned to another port. Remember, only one use of each is allowed.

2. **Activate the arrow next to the device type to set its communication parameters.**

The screenshot shows a dialog box titled "Control Port PORT #2". It is divided into three main sections: "BAUD RATE", "PARITY", and "STOP BITS".

- BAUD RATE:** A vertical list of buttons with values 9600, 4800, 2400, 1200, 600, 300, and 110. The 9600 button is highlighted with a black background.
- PARITY:** A vertical list of buttons with values NONE, ODD, EVEN, SPACE, and MARK. The NONE button is highlighted with a black background.
- STOP BITS:** A vertical list of buttons with values 1 and 2. The 2 button is highlighted with a black background, and a black arrow points upwards to it.

At the bottom center of the dialog is a "RETURN" button.

Figure 3-25: Control Port Dialog

The corresponding dialog appears.

Select the desired baud rate, parity, and stop bits.

NOTE: Factory settings are 9600 baud, no parity, 1 stop bit. Data bits, which cannot be manually set, are 8 data bits.

3. **Exit the menu system and cycle the power on the CR-100.**

The CR-100 implements the new settings.

Designating a USB Device Type

1. **Activate the menu system** (see *Activating the Menu*, on page 27).

The Main Menu appears (see Figure 3-1: Main Menu, on page 28).

2. Select DEVICES.

The Devices menu appears (see Figure 3-18: Devices menu, on page 47).

3. Select USB PORTS.

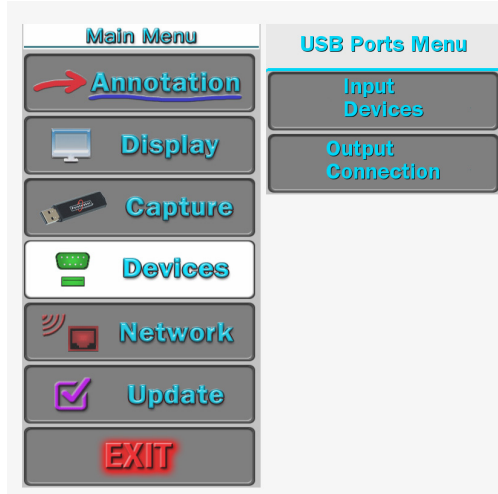

Figure 3-26: USB Devices Dialog

4. Select INPUT DEVICES

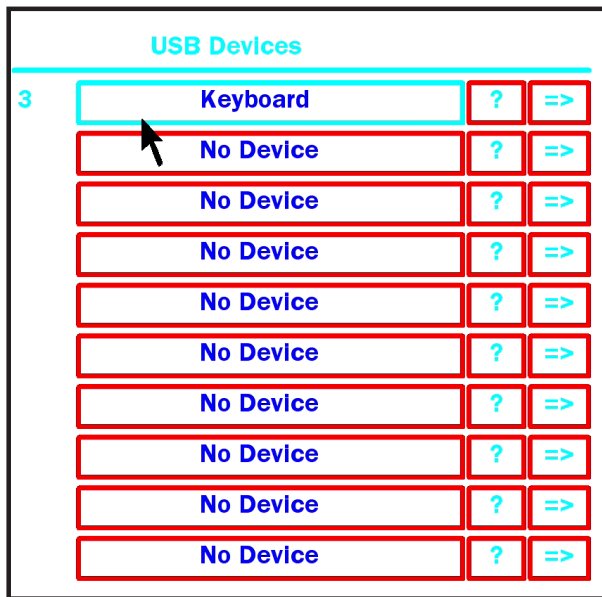

Figure 3-27: USB Devices Dialog

The USB Devices dialog appears.

Up to 10 USB devices can be connected through the use of hubs.

NOTE: All the USB devices installed on your CR-100 are listed by port number, with the device type displayed to the right of each number. If the device type is in blue, it has been assigned through the autodetect procedure at startup.

NOTE: When the question mark to the right of the device is selected, the system displays the vendor and product ID for the device.

5. (optional) Select the device type you wish to have permanently assigned.

By selecting the device, it becomes permanently assigned. The text color then changes from blue to black. With the device permanently assigned, the next time the CR-100 is powered up, the autodetect procedure will skip this device.

The system does an excellent job of immediately detecting and recognizing USB devices, even when their position on the hub changes. There are two instances where you might want to permanently assign a device type to a device (so autodetect won't try to re-assign it at the next boot-up): 1) if the device was marketed after your CR-100 system was manufactured or 2) if the system misidentifies the device.

6. (optional) To manually change the device type, select the arrow to the right of the device type you wish to change.

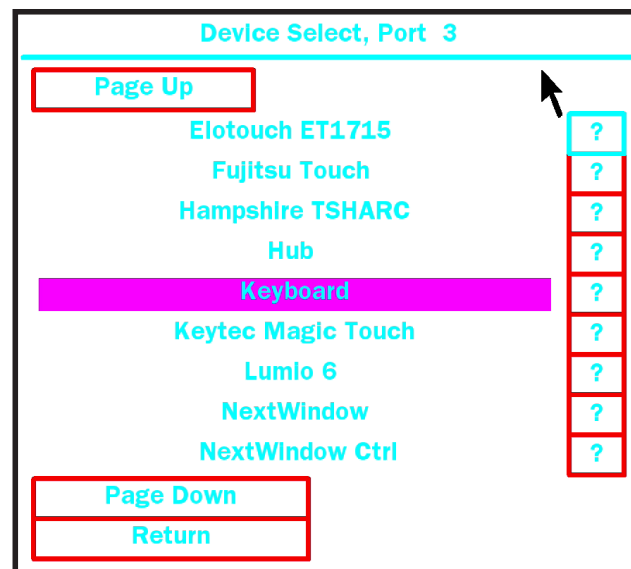

Figure 3-28: Device Select Dialog (Your listing may differ.)

The Device Select dialog appears.

This dialog presents a scrolling list of all device types currently supported by the CR-100 in alphabetical order. The Page Up and Page Down buttons allow you to quickly scroll through the names until you find the device type you desire. When you locate and select the name you wish to assign, it will move to the center of the list, where it will be highlighted. The new device type is now assigned.

When a “?” button is selected, a screen with further information about that device type will be displayed.

The “Return” button returns you to the Device Select dialog.

Setting the Tablet Template

The CR-100 ships with two standard tablet templates: Presenter and Broadcaster. When you select a paper template to use, you must also select the same template in the CR-100 menu system.

The Presenter template includes more options than the Broadcaster template. The Broadcaster template features only the most commonly used marking functions preferred for on-air use.

1. **Activate the menu system** (see *Activating the Menu*, on page 27).

The Main Menu appears (see *Figure 3-1: Main Menu*, on page 28).

2. **Select DEVICES.**

The Devices menu appears (see *Figure 3-18: Devices menu*, on page 47).

3. **Select TABLET TEMPLATE.**

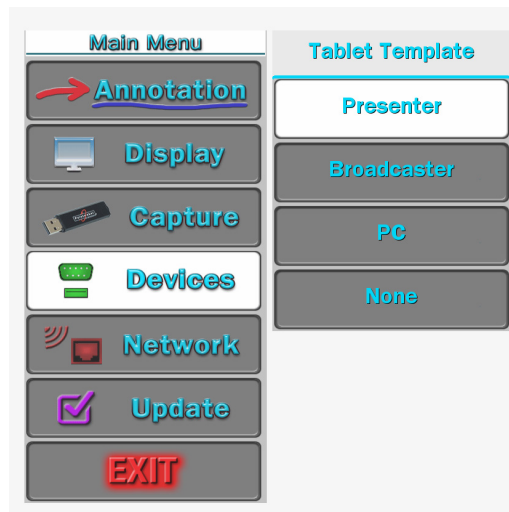

Figure 3-29: Tablet Template Menu

The Tablet Template Menu appears.

4. **Activate the template you'll be using by selecting it.**

White fills the background of your selection.

5. **Exit the menu system.**

You can now use the corresponding paper template in the tablet.

Network Features

The networking capabilities built into the CR-100 support various functions on a TCP/IP network. Currently, you can print to a color Postscript printer, and share images with other Pointmaker annotation systems using our Multipoint software. Programmers can also use the network connection to send Pointmaker commands.

Network Setup

1. **Activate the menu system** (see *Activating the Menu*, on page 27).

The Main Menu appears (see *Figure 3-1: Main Menu*, on page 28).

2. **Select the NETWORK option.**

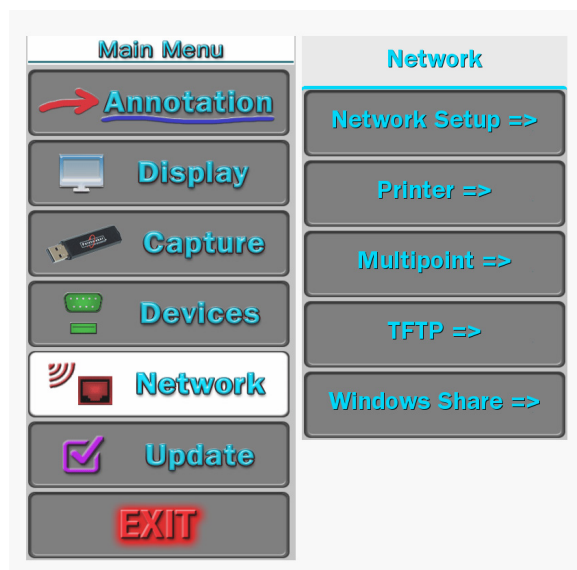

Figure 3-30: Network Menu

The Network Menu appears.

3.

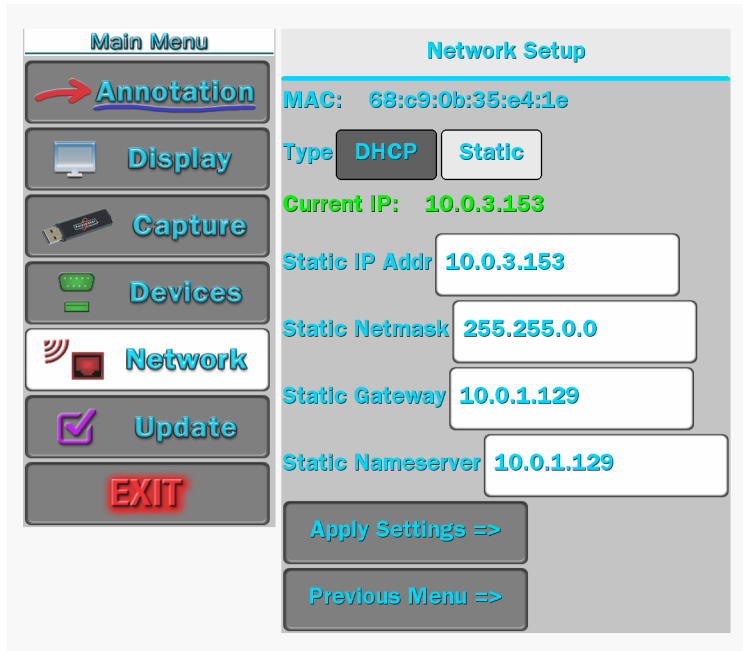

Figure 3-31: Network Setup dialog w/sample data

The Network 1 Setup dialog appears.

This dialog prepares the CR-100 for communicating on your network.

The Network 1 and Network 2 dialogs are identical except for setting the Nameserver, which is only found in this dialog. They correspond to the two network ports at the back of the unit.

4. Select DHCP or STATIC.

If DHCP is selected, IP ADDRESS, NETMASK, GATEWAY and NAMESERVER are assigned automatically.

If STATIC is selected, you must make entries for IP ADDRESS, NETMASK, GATEWAY and NAMESERVER. (This is the default setting.)

Consult with your IT administrator if you need help with these entries.

5. Select APPLY SETTINGS to finish the network configuration.

6. Exit the menu system.

Printer Setup

The CR-100 can print to a color Postscript printer over a TCP/IP network. This section shows you how to set it up.

1. **Activate the menu system** (see *Activating the Menu*, on page 22).

The Main Menu appears (see *Figure 3-1: Main Menu*, on page 28).

2. **Select the NETWORK option.**

The Network Menu appears (see *Figure 3-30: Network Menu*, on page 58).

3. **Select the Printer option.**

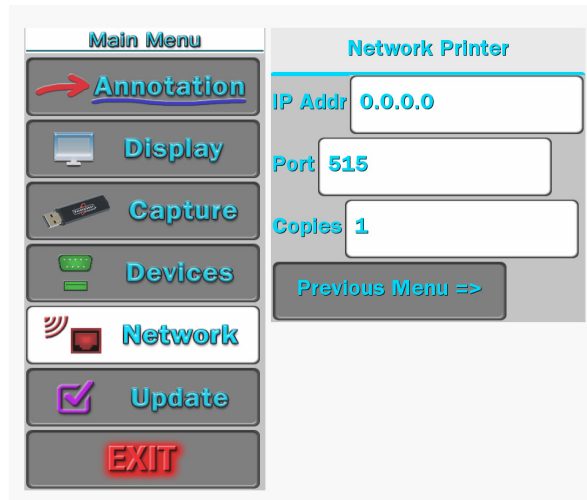

Figure 3-32: Network Printer dialog

The Network Printer dialog appears.

4. **Enter the IP address of the Postscript printer.**

Check with your IT administrator if you don't know this address.

5. **Enter the Port number.**

This is usually 515.

6. **Enter the number of copies to be printed each time you give the Print command.** (see *Printing Images* on page 100)

7. **Exit this dialog by selecting Previous Menu.**

The next time you give the Print command, it will use these settings.

Multipoint

The Pointmaker Multipoint© feature gives multiple Pointmaker users the ability to interactively mark over a common image. It utilizes the TCP/IP protocol common to the Internet, in effect allowing the participants to be anywhere in the world.

PVI-Server Requirements

A computer running the PVI-Server software is required to coordinate meetings with multiple Pointmaker units. A copy of the server software is available on request. As an alternative, you are also welcome to use a Pointmaker LLC sponsored server, which is set up on the internet.

Configure the Network Settings

The following steps are required to allow the unit to communicate with other Pointmakers over a TCP/IP network.

1. **Activate the menu system** (see *Activating the Menu*, on page 27).

The Main Menu appears (see *Figure 3-1: Main Menu*, on page 28).

2. **Select the NETWORK option.**

The Network Menu appears (see *Figure 3-30: Network Menu*, on page 58).

3. **Select the Multipoint option.**

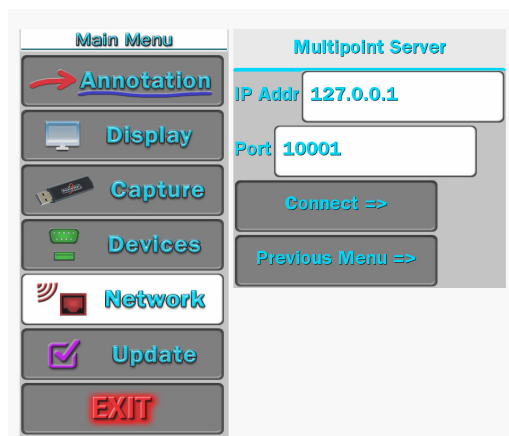

Figure 3-33: Multipoint Network dialog

The Multipoint Server dialog appears.

The information entered into this dialog is technical and not usually understood by the average user. You may need to acquire it from your IT department or your ISP. It may help to make a copy of this page for them.

4. Enter the IP address of the computer acting as your Multipoint server.

Check with your IT administrator if you don't know this address.

You may use our server at 199.223.210.127

5. Enter the Port number.

This is usually 10001. Our server's port number is 10001.

6. Continue to the next section.

Create, Join or Exit a Multipoint Meeting

Once all the previous steps have been accomplished, the Pointmaker unit is ready to support the Multipoint features. These steps explain how you can create a Multipoint meeting that other Multipoint enabled Pointmakers can join. We also explain how you can join a Multipoint meeting that someone else has created. Finally, we explain how to exit a meeting you have joined.

1. Select CONNECT.

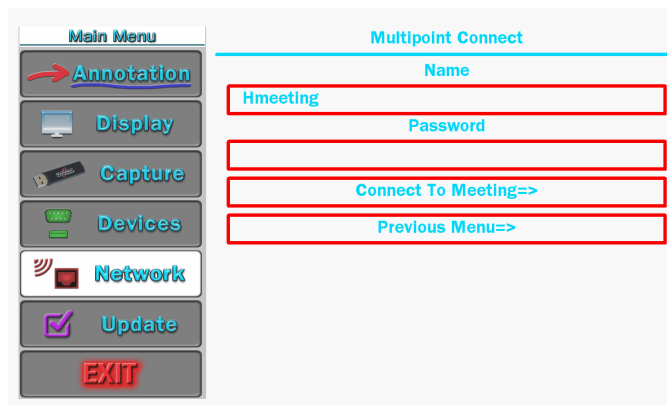

Figure 3-34: Multipoint Connect dialog

The Multipoint Connect dialog appears.

2. If needed, enter the NAME of the meeting and the PASSWORD you wish to assign.

You will need to communicate your choices for name and password to each of the other people who will be attending the meeting.

3. Exit the menu system.

You can now interactively mark over any displayed images.

OR:

4. If you wish to exit a meeting you have joined, select EXIT MEETING. You are disconnected from the meeting. You may select a different menu option or exit the menu system

Configure TFTP Settings

The Pointmaker TFTP feature gives you the ability to save and retrieve images using the TFTP protocol. To save a file using TFTP, you must first install a TFTP server on the computer which will receive the file(s). There is a free TFTP server available from solarwinds.com which has been tested successfully with the CR-100. You will need the IP address of the server where TFTP is installed. It's also important to make sure your firewall does not block it.

The following steps are required to allow the unit to communicate with the computer where TFTP has been installed and set up.

1. **Activate the menu system** (see *Activating the Menu*, on page 27).

The Main Menu appears (see *Figure 3-1, Main Menu*, on page 28.)

2. **Select the NETWORK option.**

The Network Menu appears (see *Figure 3-30, on page 58*).

3. **Select the TFTP option.**

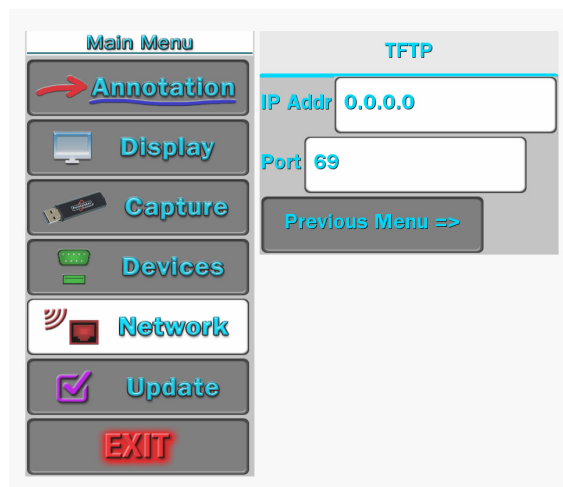

Figure 3-35: TFTP Setup Dialog

The TFTP setup dialog appears.

4. Enter the IP address of the computer where you've installed TFTP.

Check with your IT administrator if you don't know this address.

5. Enter the Port number.

This is usually 69. Again, check with your administrator

6. Exit this dialog by selecting Previous Menu.

Configure Windows Share (SMB) Settings

The Pointmaker Windows Share (SMB) feature gives you the ability to save and retrieve images using the SMB protocol. To save a file using SMB, you must first activate a Share on a server with the SMB protocol running. The setup dialog requires a Server and Share name. If the Share is password protected, you will need the username and password. It's also important to make sure your firewall does not block it.

The following steps are required to allow the unit to communicate with the computer where SMB has been installed and set up.

1. Activate the menu system (*see Activating the Menu, on page 27*).

The Main Menu appears (*see Figure 3-1, Main Menu, on page 328*.)

2. Select the NETWORK option.

The Network Menu appears (*see Figure 3-30, on page 58*).

3. Select the WINDOWS SHARE option.

The Windows Share setup dialog appears.

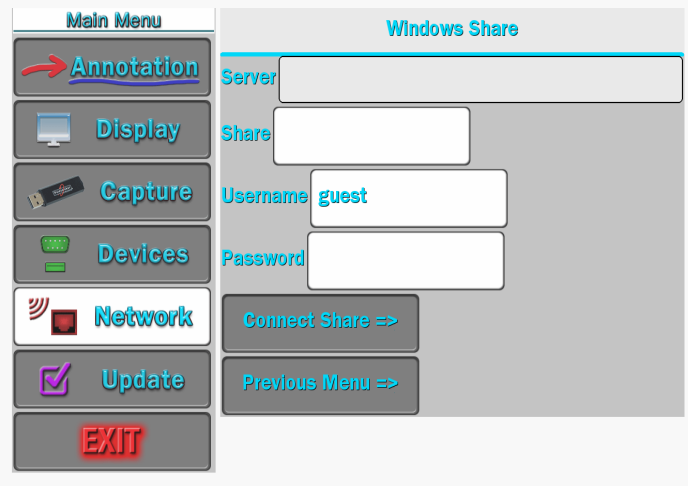

Figure 3-36: Windows Share Setup Dialog

4. Enter the Server name where your share is located.

Check with your IT administrator if you don't know the name.

5. Enter the Share name.

This is the name assigned to the location on the server. Again, check with your administrator.

6. Enter the Username and Password, if any.

Your administrator will have this information too.

7. Select the Connect Share button to connect the Pointmaker to the Windows Share.

The Pointmaker will indicate if it is able to connect to your Share. If it fails, check your settings.

8. Exit this dialog by selecting Previous Menu.

SECTION FOUR:
USING MARKERS

OVERVIEW

This section covers marking procedures you might follow while making a presentation. It is assumed that you have made set-up selections sometime before your presentation (*see Preparing the CR-100 for Use, on page 31*).

The Pointmaker features a variety of graphics, called markers, which you place over a video image to draw attention to or explain details of the image. The markers available include freehand drawing and a variety of pointers. With the keyboard installed, you can type text, draw straight lines, size frames, and anchor a date/time label. You can place any combination of these markers on the screen, in any combination of available colors. Such a combination of markers is called a marker overlay. With the keyboard installed, you can save and retrieve up to 25 different marker overlays.

This section assumes that you are familiar with the operational buttons of your control device, and how to use them to anchor a marker and draw .

Instructions for marking are divided into the following categories:

- **Assigning Marker Appearance**
- **Marking**
- **Clearing Markers**
- **Using the Chalkboard**
- **Displaying Different Overlays**

ASSIGNING MARKER APPEARANCE

While the marker is still active, and before you begin to draw or place markers, you can change the appearance of your drawing or next marker in one of several ways.

- **Assign Marker Color**
- **Assign Line Style**
- **Assign Pointer Type**
- **Turn Pointer On/Off**

Assigning Marker Colors

The color that the active marker displays is the color that the marker will be anchored in. You can anchor markers of different colors on a single overlay.

The colors available during a presentation are based on those activated in the Color Palette menu (*see Customizing the Color Palette, on page 31*).

If the color of the markers does not change from black, the brightness level is too low and must be increased before selecting the color .

From Any Controller

Activate the Change Color command from your control device.

(see Using The Chalkboard, on page 87).

All markers anchored from this point on will appear in the newly selected color.

NOTE: If the pointer has been disengaged, and the Display Color Change option in the Color Palette Menu has been activated, a small block of color will briefly appear in the lower right of the screen to help you identify the new marker color. The Display Color Change block does not appear when using the digitizing tablet.

NOTE: In mouse devices, be careful to click the tip (or first) button rather than press it. Pressing the tip (or first) button could inadvertently toggle the pointer on/off or cause the menu system to appear.

You can have drawn lines of different styles on a single overlay. Once you draw the line, or anchor a straight line, you cannot change that line style. However, you can erase or undo the drawing and begin again (*see Erasing Markers, on page 84*).

Assigning Line Styles

You can change line style directly from the digitizing tablet or from the keyboard. You can also change the line style from other devices by accessing the menu system. When the keyboard is installed, you can only access the menu system from the keyboard.

When a line style is selected from a marking device, the CR-100 keeps track of the style and the device. The device will draw with that style until a different style is selected. This allows each marking device to have its own line style.

From the Digitizing Tablet

1. Click the pen tip on the line style icon on the tablet template.

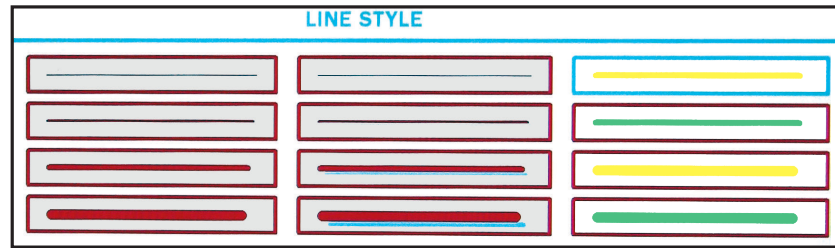

Figure 4-1: Line Style pop-up

The Line Style pop-up appears on the screen.

2. Select the line style you wish to draw with.

It includes various thicknesses of plain lines, lines with shadows, and highlight lines. The highlight lines available on the pop-up are yellow and green. The current video source shows through the highlight lines area to give an idea of how the colors work with that source. A third color, pink, can be obtained by touching the Change Color key on the keyboard, after you select a highlight line in the pop-up.

3. The pop-up disappears.

All lines drawn from this point on will appear in the newly selected line width and style.

From the Keyboard

1. Activate the Line Style command.

A small sample of the active line style will appear briefly in the lower-right hand corner of the screen.

2. **Repeatedly activate the Line Style command until the desired line style appears in the on screen sample.**

You can scroll backwards through the line options, by activating the Reverse Toggle command.

All lines drawn from this point on will appear in the newly selected line width and style.

From the Menu System

1. **Activate the menu system** (see *Activating the Menu*, on page 27).

The Main Menu appears (see *Figure 3-1, Main Menu*, on page 28).

2. **Select the ANNOTATION option**

The Annotation menu appears (see *Figure 3-2, Annotation Menu*, on page 32).

3. **Select the LINE STYLE option.**

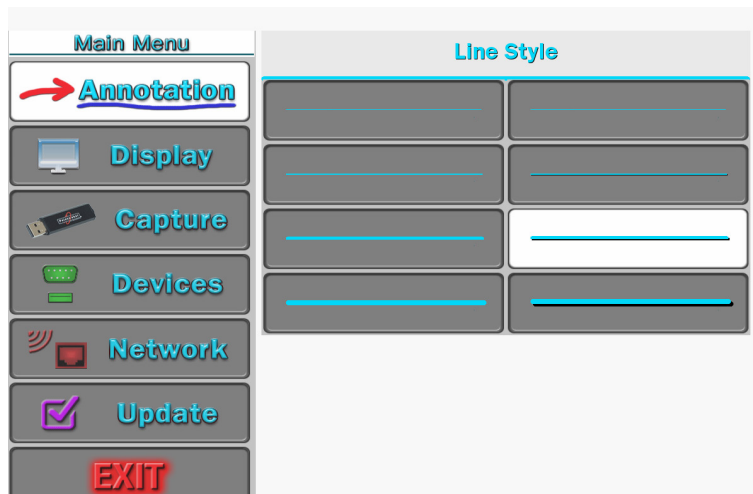

Figure 4-2: Line Style Menu

The Line Style Menu appears.

4. **Select the fine, medium, or bold line, with or without a drop shadow.**
5. **The active option displays a white fill.**

NOTE: Drop shadows are always black, therefore, black lines do not have drop shadows.

6. Exit the menu system.

All lines drawn from this point on will appear in the newly selected line width and style.

Selecting Pointers

You select a pointer type while the pointer is active, or positionable. After you anchor the pointer, you cannot change that pointer's type. However, you can erase or undo the anchored pointer and begin again (*see Erasing Markers, on page 86*).

From the Digitizing Tablet

1. Click the pen tip on the desired pointer icon on tablet.

The corresponding active pointer appears on screen, ready for positioning or anchoring.

From the Keyboard

1. Repeatedly activate the POINTERS command until the desired pointer type appears on screen.

You can scroll backwards through the pointer options, by activating the Reverse Toggle command.

The pointer you selected appears on screen, ready for positioning.

From the Menu System

1. Activate the menu system (*see Activating the Menu, on page 27*).

The Main Menu appears (*see Figure 3-1, Main Menu, on page 28*).

2. Select the ANNOTATION option

The Annotation menu appears (*see Figure 3-2, Annotation Menu, on page 32*).

3. Select the POINTERS option.

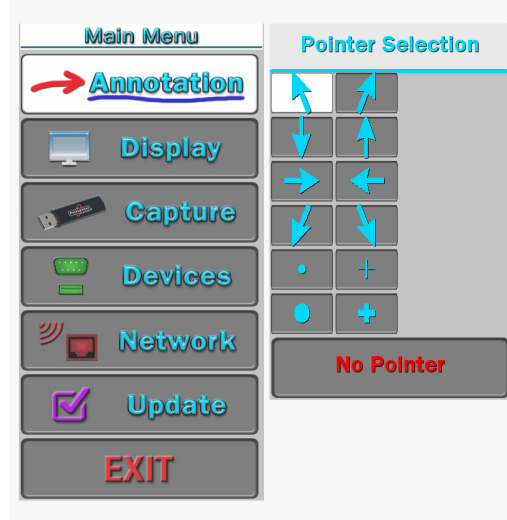

Figure 4-3: Pointers dialog

The Pointers dialog appears.

4. Select a pointer type.

The active option displays a white fill. Selecting NO POINTER turns the pointer off.

5. Exit the menu system.

Turning the Active Pointer On/Off

Sometimes a presenter chooses not to have the pointer showing during a presentation. This command allows you to turn the visibility of the pointer off or on. When the active pointer is turned off, you can still anchor pointers.

From the Digitizing Tablet

Since touch screens and whiteboards do not display active pointers, you do not need to use the Pointer On/Off command with those devices.

NOTE: An alternative to the Pointer On/Off command, is using the Pen Proximity feature available on the tablet template or through the menu system. When active, this feature causes the active pointer to disappear each time you remove your drawing device from proximity of the tablet or screen drawing surface (see *Changing Pen Proximity*, on page 35).

1. Press the Pointer On/Off icon on the tablet Menu Strip.

The pointer disappears.

2. **To make the pointer reappear, repeat the procedure.**

From the Keyboard

1. **Activate the Pointer On/Off command.**

The pointer disappears.

2. **To make the pointer reappear, repeat the procedure.**

NOTE: To turn off all active markers, including active frames, use the keyboard Active Marker On/Off command.

From the Menu System

Pointers are turned off in the same dialog where they are selected (*see Turning the Active Pointer On/Off, on page 75*).

MARKING

This section covers pointing and drawing procedures. The following outline lists the procedures in the general order that most presenters use them.

- **Entering the Marking Mode**
- **Pointing (with positionable or anchored pointers)**
- **Drawing**
- **Typing Text (keyboard installed)**
- **Framing (keyboard installed)**
- **Stamping the Date/Time**

Entering the Marking Mode

The Pointmaker is in the marking mode by default. The only time it is not in marking mode is when a menu is displayed. In the Marking mode, the image from the video source is displayed along with any stored markers. An active pointer is also displayed, unless it was disabled during setup.

Pointing

You can move the pointer around the screen, using it to direct the viewer's attention without anchoring it. You can also position and anchor several pointers on the overlay, giving you the opportunity to point in a more lasting manner on several areas of the image.

Before using or anchoring a pointer, you may want to select a new pointer type (*see Selecting Pointers, on page 74*). Or you may change the pointer color (*see Assigning Marker Colors, on page 71*).

From Any Controller

- 1. Position the pointer anywhere on the video image to direct attention to an image detail.**

Refer to instructions for "Point" under your particular control device (*see Activating the Chalkboard, on page 87*).

2. **If desired, reposition the same active pointer anywhere on the image to make your second point, and continue as often as desired.**

3. **If desired, anchor the active pointer.**

Refer to instructions for “Anchor” under your particular control device.

The pointer is anchored and a new active pointer appear on screen, identical to the first.

NOTE: Active pointers are not displayed for touch screens, only anchored markers.

4. **Repeat any of these steps as often as desired.**

Drawing

You can draw on the Pointmaker overlay simply by beginning to draw. The drawing feature allows you to circle important parts of the image, write on the image, or underscore particular parts of text. You can draw freehand curves or straight lines.

To draw, you can use the digitizing tablet stylus on the tablet drawing area, your finger on a touch screen, or a magic marker on the SMART Board. You can also use other mouse devices to draw. You cannot freehand draw using the keyboard, but you can use it for straight line drawing.

Before drawing, you may wish to change the drawing line color (*see Assigning Marker Colors, on page 71*). Or you may wish to change the width and style of the drawing line (*see Assigning Line Styles, on page 72*).

Drawing Freehand

1. **Position the active pointer (if one is displayed) anywhere on the video image where the drawing is to begin.**

NOTE: If you are using a touch screen or whiteboard, position a finger or marker pen.

2. **Activate the Draw command from your particular drawing device.**
3. **Reposition the active marker (if one is displayed) and repeat the above procedures for another drawn line.**

NOTE: You may create as many drawings as desired.

Straight Line Drawing

This feature works only using the keyboard.

- 1. Activate the Straight Draw command from the keyboard.**

A cursor appears representing the first endpoint of the straight line.

- 2. Position the cursor anywhere on the screen where the line is to begin, and anchor it.**

A second cursor appears, joined by a line to the first endpoint.

- 3. Position the second cursor where the line is to end and anchor it.**

The line segment is complete.

- 4. If desired, draw another straight line by positioning the new active cursor and anchoring it.**

NOTE: You may anchor many lines as desired.

Typing Text Labels

Anytime you press an alphanumeric key on the keyboard, a text label begins. Before you anchor a line of text, you can choose to display it in one of six (6) fonts, each of which offers one or more sizes. These fonts are (in order): TI Roman (4 sizes); Helvetica (4 sizes); TI Dom Casual (4 sizes); Fargo (3 sizes); Symbol (1 size); and Map (1 size). Symbol and Map fonts are charted in Section Five: Appendices.

- 1. Position the active marker anywhere on the image.**

- 2. Create a line of text by pressing the desired text keys.**

NOTE: Do not anchor this line of text yet, since only an active (or positionable) line of text will display the font options.

- 3. Select the desired font by repeatedly activating the Fonts command until the font appears on screen.**

You can scroll backwards through the font options, by activating the Reverse Toggle command.

- 4. Select a font size by repeatedly activating the Font Size command until the correct size appears on screen.**

You can scroll backwards through the size options, by activating the Reverse Toggle command.

5. **Turn the text background on or off by activating the Text Background On/Off command.**

NOTE: The color of the background is always blue.

6. **Position the active label anywhere on the video image, then anchor the label.**

The line of text is anchored. You can anchor a new line of text immediately below the previously anchored text line by not moving the cursor. Or you can position the second line of text anywhere on the screen.

NOTE: To create a paragraph of several lines of text, remember that text does not wrap, so press ENTER or DROP [Insert] at the end of each line.

7. **Exit text typing mode by pressing any other function key.**

Sizing and Anchoring Frames

This feature works only using the keyboard.

The Pointmaker features four frame types: box frame, circle frame, solid box frame, and solid circle frame. Frames remain active (sizable and positionable) until you anchor them.

Before anchoring a frame, you may want to change the frame color (*see Assigning Marker Colors, on page 71*).

1. **Select a frame type by repeatedly activating the Frames command until the desired frame appears.**

You can scroll backwards through the font options, by activating the Reverse Toggle command.

The active frame appears, ready for sizing and positioning. A crossed line displayed within the boundaries of an active frame represents a solid frame. The frame will be filled with the color of the active marker after you anchor it.

2. **Enter the Sizing mode by activating the Size Frames command.**

The frame is now sizable.

3. **Size the frame using the keyboard or other controller.**

Upward commands make the frame taller. Downward commands make the frame shorter. Leftward commands makes the frame wider. Rightward commands make the frame narrower.

For finer control in sizing, activate the Fine Positioning command.

4. **Store the size by pressing the ENTER or DROP [Insert] key.**

The sized frame is ready for positioning.

5. Position the sized frame anywhere on the image, then anchor it.

A new active frame appears, identical to the first.

6. If desired, size and position the new active frame anywhere on the video image to frame a second area.

7. Exit Frames by pressing any other function key.

Stamping the Date/Time

This feature works only using the keyboard.

You can “stamp” an overlay with the current date and/or time, depending on which display mode you selected in the Set Date/Time Menu (*see Assigning Marker Colors, on page 71*).

While active (or positionable) the date/time stamp is represented by an icon. The numerical date and/or time will appear as soon as you anchor the icon. You can anchor only one Date/Time stamp on each overlay. To reposition a stamp, activate the command again. The old stamp disappears and the new stamp appears, ready for positioning.

Before anchoring a date/time stamp, you may want to select a new color for the stamp's text (*see Assigning Marker Appearance, on page 71*).

1. Activate the Show Date/Time command.

A date/time icon appears.

2. Position the date/time icon anywhere on the video image.

3. To select a solid or transparent label background, activate the Text Background On/Off command.

4. Anchor the date/time label.

The current date/time label appears. A date/time cursor also appears on screen, ready for the next action.

CLEARING MARKERS

After you anchor markers (drawings, lines, frames, and pointers), you may want to clear the screen of all or some of the markers before proceeding to the next point of discussion. You can erase markers in one of the three following ways:

- **Clearing All Markers**
- **Undoing the Most Recent Marker**
- **Erasing Markers**

If you don't want to clear markers, but just need to temporarily remove the marker overlay, then use the Marker Overlay On/Off command (see *Turning Off the Marker Overlay*, on page 89).

Clearing All Markers

Follow these instructions to clear the entire screen of markers.

From the Digitizing Tablet

Select the CLEAR icon on the tablet Menu Strip.

All markers disappear. An active pointer remains on screen unless the pointer has been disengaged.

NOTE: Markers are cleared even if you are in PC Mode.

From Other Controllers

Activate the Clear command for your particular controller.

All markers disappear. An active pointer remains on screen unless the pointer has been disengaged.

Undoing a Marker

Follow these instructions to undo a marker, beginning with the most recently anchored marker or line segment. You can repeat this command as often as needed until the screen is clear of markers.

From the Digitizing Tablet

Press the tip button on the UNDO icon located on the tablet Menu Strip.

The most recently anchored marker disappears. An active pointer remains on screen unless the pointer has been disengaged.

NOTE: You can undo markers even if you are in PC Mode.

From Other Controllers

Activate the Undo command for your particular controller.

The most recently anchored marker disappears. An active pointer remains on screen unless the pointer has been disengaged.

Erasing Markers

Follow these instructions to erase markers from the overlay, wiping them clear like a traditional eraser. You activate Erase mode from the menu system, but you erase the markers using your drawing device.

When you are in Erase mode, you can no longer undo markers. Conversely, when you are in Undo Mode, you cannot erase markers.

NOTE: Entering Erase mode clears markers from any overlays that you might have stored.

Activating Erase Mode

1. **Activate the menu system** (see *Activating the Menu*, on page 27).

The Main Menu appears (see *Figure 3-1, Main Menu*, on page 28).

2. **Select the ANNOTATION option**

The Annotation menu appears (see *Figure 3-3, Annotation Menu*, on page 32).

3. **Select ERASE METHOD.**

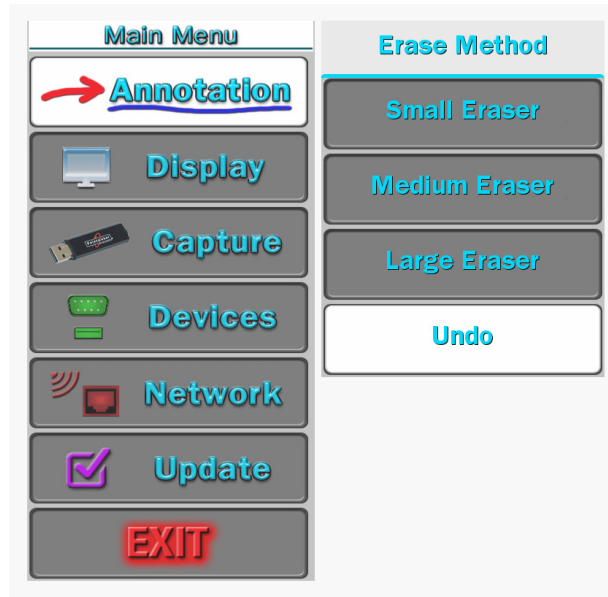

Figure 4-4: Erase Method Menu

The Erase Method dialog appears.

4. Select an eraser size SMALL, MEDIUM, or LARGE.

The active size displays a white fill.

NOTE: The larger the eraser size, the more area you can clear in a single motion. If you do not select an eraser size, the Pointmaker will default to Medium. Selecting the UNDO option allows you to undo a marker, rather than erase it.

5. Exit the menu system.

Erasing Procedure

Follow these instructions to erase markers. Be sure you are in Erase mode before implementing these procedures (see *Erasing Markers*, on page 84).

From the SMARTBoard®

The default mode for SmartBoard operation is Clear. When you remove the eraser from the SmartBoard pen tray and touch it anywhere on the board, the Pointmaker overlay will clear.

If you would prefer to erase the Pointmaker overlay in the same way that you would erase dry erase markers, please use the following procedure:

1. **After marking, activate the Undo/Erase command.**
2. **Pick up the eraser.**
3. **Wipe the eraser over your markers.**

The markers disappear as you wipe. When you finish erasing, lift the eraser from the board. Lifting the eraser closes the eraser function, and enters Marking mode. If you need to erase again, repeat steps 1-3.

From Other Drawing Devices

1. **After marking, activate the Undo/Erase command for your particular controller.**

A square eraser appears on screen, ready for positioning.

2. **Activate the Draw command, and drag the eraser over the markers**

The markers disappear as you wipe. When you lift the drawing device (that is, your finger or stylus), the Pointmaker closes the eraser function, and enters Marking Mode. If you need to erase again, repeat steps 1-3.

USING THE CHALKBOARD

You can mark on a solid background (chalkboard) or the video image. When turned on, the chalkboard will continue to be displayed even when you select a new marker overlay. Also, the chalkboard will remain on screen until you turn it off. The chalkboard is most easily selected from the digitizing tablet or keyboard, but it can also be selected from the menu system.

Activating the Chalkboard

Use these procedures to turn on the chalkboard.

From the Digitizing Tablet

1. **Select the CHALKBOARD icon on the tablet template.**

The chalkboard command is only available on certain templates. The chalkboard appears, along with any markers you may have already anchored.

2. **To exit the Chalkboard, select the VIDEO SOURCE icon you desire.**

The video source returns, along with any markers you may have anchored on the chalkboard.

From the Keyboard

1. **Activate the CHALKBOARD ON/OFF command.**

The chalkboard appears, along with any markers you may have already anchored.

2. **To exit the Chalkboard, repeat step 1.**

The video source returns, along with any markers you may have anchored on the chalkboard.

From the Menu System

1. **Activate the menu system** (*see Activating the Menu, on page 27*).

The Main Menu appears (*see Figure 3-1, Main Menu, on page 28*).

2. **Select the ANNOTATION option.**

The Annotation menu appears (see Figure 3-3, Annotation Menu, on page 32).

3. **Select the BACKGROUND option.**

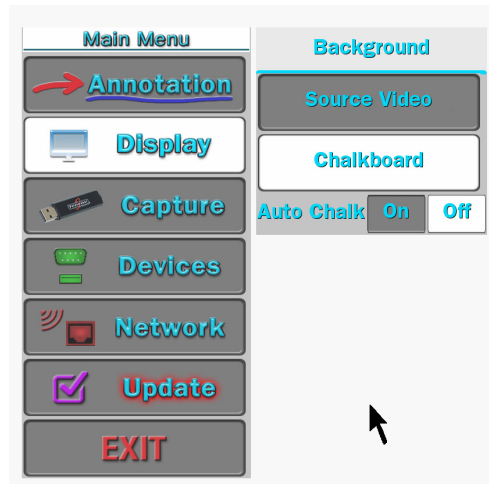

Figure 4-5: Background Menu

The Background Menu appears.

4. **Select the CHALKBOARD option.**

5. **Exit the menu system.**

The chalkboard appears, along with any markers you may have already anchored.

6. **To exit the Chalkboard, repeat steps 1-3, but select the SOURCE VIDEO option instead of CHALKBOARD.**

The video source returns, along with any markers you may have anchored on the chalkboard.

Displaying Different Overlays

With the keyboard installed, you can display one of 10 stored marker overlays. Also, you can temporarily turn off the marker overlay, without affecting the markers you store there.

This section covers the following overlay functions:

- **Paging Through Overlays (in sequence or out-of-sequence)**
- **Turning an overlay Off/On**

Paging Through Overlays

Use these instructions when the keyboard or tablet is installed and you wish to display a new overlay. After you display a new overlay you can add or clear markers from that overlay. Overlays are saved automatically.

From the Keyboard

To go to the next or previous overlay

Activate the Next Overlay or Previous Overlay command.

The next or previous overlay of markers is displayed, and an overlay # briefly appears in the corner of the screen.

To go to an out-of sequence overlay

1. Activate the Go To Overlay # command.

A small “#” sign appears in the lower-right corner, followed by an underscore prompting you to type a number.

2. Type in the overlay number.

The overlay corresponding to the number appears. This selection is confirmed by a brief display of the overlay number in the lower-right corner of the screen.

NOTE: If you do not respond within a few seconds, the overlay does not change.

Turning Off the Marker Overlay

When the keyboard is installed, you can turn off the Pointmaker overlay to view the video image without any markers. When you turn the overlay on again, the markers you anchored on that overlay will reappear. You can only activate this command from the keyboard.

1. Activate the Marker Overlay On/Off command.

The markers disappear.

2. Activate the Marker Overlay On/Off command again.

The markers reappear.

SECTION FIVE:
IMAGE MOBILITY

OVERVIEW

The Pointmaker CR-100 makes it easy to move annotated or captured images in and out of the unit. This gives you newfound flexibility in the creation and sharing of your presentations.

It is now easy to capture images, with or without annotations, by either saving or printing them. Previously saved images can be retrieved from the storage device at will. You can also retrieve an image created on computer, as long as it conforms to the file specifications. Finally, images can be shared across TCP/IP and SMB networks with other Multipoint-enabled Pointmaker video markers.

Instructions in this section are divided into the following categories:

- **Freezing Video**
- **Saving Images**
- **Retrieving Images**
- **Printing Images**
- **Sending Images**
- **Verifying Saved or Printed Images**

IMAGE MANIPULATION

The following paragraphs describe the new ways you can manipulate images using the Pointmaker CR-100. The resolution of the image is dependant on the resolution of the image you are viewing at the time.

Freezing Video

If video files are being shown as part of a presentation, the CR-100 can freeze it at any point so you can draw attention to a particular frame's contents.

To freeze a frame of video

- 1. Activate the Freeze command in one of the following ways:**
 - a) (touch screen) Touch the Top-Right command area.**
 - b) (digital tablet) Activate the “Freeze” button.**
 - c) (keyboard) Type “Alt-F1”.**

The current video frame will be frozen on the screen.

This command does not actually stop the video from playing. You will need to activate the Pause or Stop button on your video playback unit to do that.

- 2. You can now annotate the frozen image.**

You can also Save or Print the image at any time.

- 3. Activate the Freeze command again to toggle the command off.**

The running video will be displayed again.

Saving Images

- 1. The CR-100 can save displayed images in the following ways:**
 - a) moving images can first be frozen and then saved**
 - b) a single frame of a moving image can be captured “on-the-fly” as it goes by on the screen,**
 - c) any still image can be saved.**

The image can be saved to a USB memory device or to another computer using TFTP(tiny file transfer protocol) or SMB (Windows Share).

The image is saved based on the settings you've chosen (*see Capture Options on page 44*). Files are saved in bitmap format, 24 bit true color, 720x485, with the extension “.bmp”.

The USB memory device must be a single device, like a memory stick. It cannot be connected through a multiple port memory card reader. It must also be formatted as FAT16 or FAT 32.

To save an image file to a USB device

1. **Save the image file in one of the following ways:**
 - a) **(touch screen) Touch the Image Save command area** (default is center-left). Be sure the Capture File Defaults has been set to USB.
 - b) **(digital tablet) Activate the “Save” button.**
 - c) **(keyboard) Type “Alt-F2”.**

The “Alt-F2” keyboard command is programmed to save to the USB device. The other two commands are dependent on the Destination setting in the Capture dialog (*see Setting the Destination for Saved Files, on page 46*).

If you want to use the tablet or touch screen commands, be sure to set the Destination to USB first.

2. **The image is saved to the USB memory device.**

A counter appears at the lower-right portion of the screen, indicating the percentage of the image saved to the USB storage device.

When the counter reaches 100, it disappears. The system is then ready to save another image.

The name of the file is determined by the settings in the File Defaults dialog(*see Figure 3-17: File Defaults dialog, on page 45*).

To save an image file using TFTP

To save a file using TFTP, you must first install a TFTP server on the computer which will receive the file(s). There is a free TFTP server available from solarwinds.com which has been tested successfully with the CR-100. You will need the IP address of the server where TFTP is installed(*see Configure TFTP Settings, on page 64*). It's also important to make sure your firewall does not block it.

1. **Save the image file in one of the following ways:**
 - a) **(touch screen) Touch the Image Save Command area** (default is center-

left). Be sure that Capture File Defaults has been set to TFTP.

- b) (digital tablet) Activate the “Save” button.**
- c) (keyboard) Type “Alt-F6”.**

The “Alt-F6” keyboard command is programmed to save to the Computer where TFTP is installed. The other two commands are dependent on the Destination setting in the Capture dialog(*see Setting the Destination for Saved Files, on page 46*).

If you want to use the tablet or touch screen commands, be sure to set the Destination to USB first.

2. The image is saved to the computer you have designated.

A counter appears at the lower-right portion of the screen, indicating the percentage of the image saved to the TFTP server.

When the counter reaches 100, it disappears. The system is then ready to save another image.

NOTE: Operation of the CR-100 will slow down during the saving process.

The name of the file is determined by the settings in the File Defaults dialog (*see Figure 3-17: File Defaults dialog, on page 45*).

To save an image file using Windows Share (SMB)

To save a file using SMB, you must first install and setup Windows Share on the computer. (*see Configure SMB Settings, on page 64*).

1. Save the image file in one of the following ways:

- a) (touch screen) Touch the Image Save Command area** (default is center-left). Be sure that Capture File Defaults has been set to SMB
- b) (digital tablet) Activate the “Save” button.**
- c) (keyboard) Type “Alt-F8”.**

2. The image is saved to the computer you have designated.

A counter appears at the lower-right portion of the screen, indicating the percentage of the image saved to the computer. When the counter reaches 100, it disappears. The system is then ready to save another image.

NOTE: Operation of the CR-100 will slow down during the saving process.

The name of the file is determined by the settings in the File Defaults dialog (*see Figure 3-17: File Defaults dialog, on page 45*).

Retrieving Images

Saved images can be retrieved using the “Get” command. A dialog appears, allowing you to enter the number of the image you wish to on screen. When you enter the number and activate the OK button, the image is displayed. To return to the video input, again type the “Alt-F2” keyboard command.

To retrieve an image file from USB

1. Retrieve an image in one of the following ways:
 - a) (touch screen) Touch the appropriate area if you assigned this command.
 - b) (digital tablet) Activate the “Get” button.
 - c) (keyboard) Type “Alt-F3”.

The Get Image dialog appears.

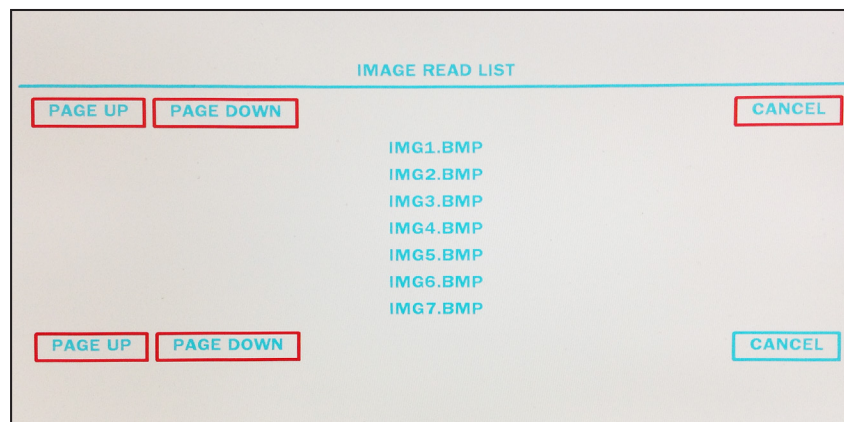

Figure 5-1: Get Image dialog

2. Select the image you wish to retrieve from the list that is presented.

The image is displayed on the screen.

To retrieve an image file using TFTP

1. Retrieve an image by typing “Alt-F7” on your keyboard,
 - a) Touch the area on your touch screen if you assigned this command.

The Get Image dialog appears.

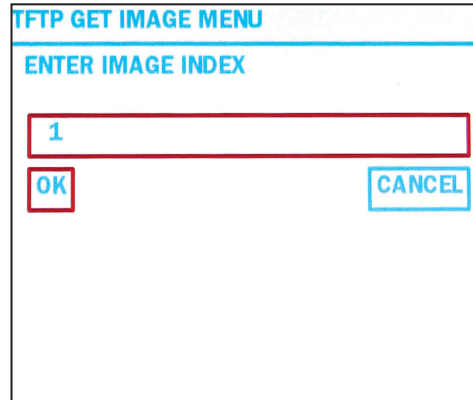

Figure 5-2: TFTP Get Image dialog

2. **Enter the image index number for the image you wish to retrieve and select OK.**

Only the number is to be entered. The prefix of the file is determined by the settings in the Image File dialog (see *Figure 3-17: File Defaults dialog, on page 45*). If you have changed the prefix setting in order to help group files for a particular purpose, make sure the prefix in the Image File dialog matches the prefix of the file you are attempting to retrieve.

The file extension must be “bmp”.

The image is displayed on the screen.

To retrieve an image using Windows Share (SMB)

1. **Retrieve an image in one of the following ways:**
 - a) (touch screen) Touch the appropriate area if you assigned this command.
 - b) (digital tablet) Activate the “Get” button.
 - c) (keyboard) Type “Alt-F3”.

The Get Image dialog appears.

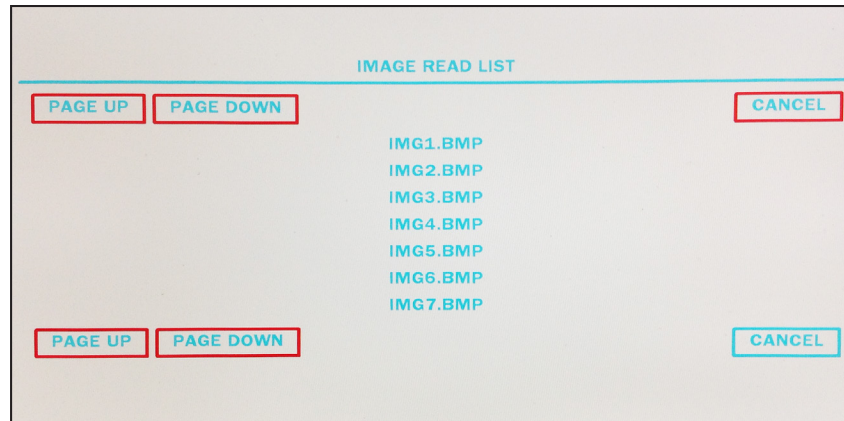

Figure 5-3: Get Image dialog

2. Select the image you wish to retrieve from the list that is presented.

The image is displayed on the screen.

Printing Images

The CR-100 allows you to print to a color Postscript printer either directly or over a TCP/IP network. If you print directly, the configuration requires a USB to Centronics cable. Contact Boeckeler Instruments if you want to use a direct connection. To print over a TCP/IP network requires an ethernet cable and the address of the printer (*see Printer Setup, on page 60*).

To print an image

1. Print an image in one of the following ways:
 - a) (touch screen) Touch the Center-Right command area.
 - b) (digital tablet) Activate the “Print” button.
 - c) (keyboard) Type “Alt-F4”.
2. The image is sent to the printer.

A counter appears at the lower-right portion of the screen, indicating the percentage of the image sent to the color Postscript printer.

When the counter reaches 100, it disappears. The system is then ready to print another image.

Sending Images

The CR-100 allows you to send images to other CR-100's over a TCP/IP network. All units must be currently active in the same Multipoint meeting (see *Multipoint*, on page 61)

To send an image

1. **Send an image in one of the following ways:**
 - a) (touch screen) Touch the Center-Bottom command area.
 - b) (digital tablet) Activate the “Send” button.
 - c) (keyboard) Type “Alt-F5”.
2. **The image is sent to everyone logged-in to the Multipoint meeting.**

It appears on their screens, along with whatever annotations have been made.

3. **All members of the meeting can now interactively annotate over the image.**

Verifying Saved or Printed Images

In circumstances where it is important to know that a file has been successfully saved or printed, you will want to activate the VERIFY setting (see *Setting the Verify Option*, on page 46). Once it is active, each time you print or save a file, a dialog will appear, asking you to verify that the image was successfully saved or printed.



Figure 5-4: Verify dialog

SECTION SIX:
USING RS-232 COMMANDS

OVERVIEW

Use following commands to program A/V programmable remote control systems so that each Pointmaker CR-100 model can be operated from a remote device.

Note: The RS-232 commands listed here are a complete list for all products. Not all commands apply to the CR-100.

All commands begin with an ASCII escape (<Esc>) code (generated using the Esc key on your keyboard), followed by the forward parenthesis “ (”. The initiating code then appears as follows:

<Esc>(

All other characters which follow this command require a combination of alphanumeric codes.

NOTE: Hardware handshaking is required with the Pointmaker RS-232 port. Also, you will need to use a null modem cable.

Some places in the manual refer to entering a carriage return. This is usually accomplished by hitting the Enter key on your keyboard.

Ø is used to designate zero.

X-Y Coordinate Grid

Numerous commands refer to a screen grid with coordinates based on an internal grid that is 2048 x 2048 units. The grid can be absolute, covering the entire screen area, or relative to a current position. The absolute grid coordinate of 00000000 is at the upper-left of the screen. The grid coordinate of 20472047, then, is in the lower-right. Relative grid coordinates can include negative numbers to indicate positions above or left of a current position. In the illustration below, XXXX = a numeric value for the horizontal axis. YYYYY = a numeric value for the vertical axis.

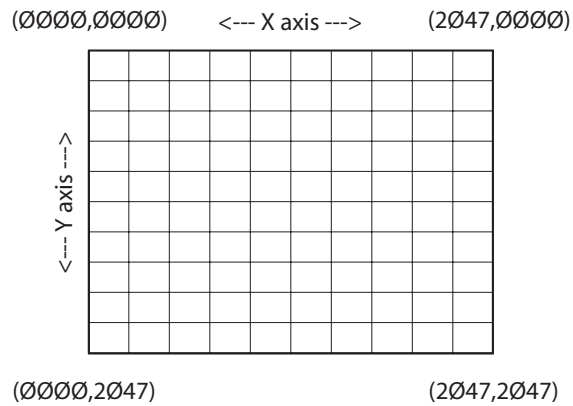

Figure 6-1: Screen Grid

(A) Autodetect Video Input

The “A” command tells the Pointmaker whether to automatically detect what video input to switch to.

<Esc>(A1	Enables Autodetect
<Esc>(A0	Disables Autodetect

NOTE: The Autodetect command is overridden by the Video Input Type (M) command.

(AI) Audio Input

The “AI” command allows you to assign which input the audio is coming from.

<Esc>(AIV	This command determines the audio input based on the current video source as follows: For Composite, Y/C, or VGA: the analog (Audio) input is used. If a digital video (HDMI) source is selected, the digital audio from that source is used.
<Esc>(AIA	Analog (Audio) input is always used.

(AO) Audio Output

The “AO” command allows you to enable or disable audio output independently for analog (Audio) output and each of the digital (HDMI) audio outputs.

<Esc>(AOAØ	Audio output for analog audio is disabled.
<Esc>(AOA1	Audio output for analog audio is enabled.
<Esc>(AOAT	Audio output for analog audio is toggled between on and off.

<Esc>(AO2Ø	Audio output for HDMI port 2 is disabled.
<Esc>(AO21	Audio output for HDMI port 2 is enabled.
<Esc>(AO2T	Audio output for HDMI port 2 is toggled between on and off.

<Esc>(AO3Ø	Audio output for HDMI port 3 is disabled.
<Esc>(AO31	Audio output for HDMI port 3 is enabled.
<Esc>(AO3T	Audio output for HDMI port 3 is toggled between on and off.

(AOV) Audio Volume

The “AOV” command controls audio volume. nnn refers to a 3 digit decimal number ranging from 0 to 100. It represents a percentage of the volume.

<ESC>(AOVMnnn	Sets master volume
<ESC>(AOV2nnn	Sets 2 HDMI audio output
<ESC>(AOV3nnn	Sets 3 HDMI audio output
<ESC>(AOVAnnz	Sets analog audio output
<ESC>(AOVUnnn	Sets USB audio output

(B) Background

The “B” command tells the Pointmaker which background to use.

<Esc>(BV	Video Background
<Esc>(BC	Chalkboard Background
<Esc>(BT	Video/Chalkboard Toggle
<Esc>(BL1	Display Text Background (on text and date/time labels)
<Esc>(BLØ	No Text Background (on text and date/time labels)
<Esc>(BLT	Toggle Text Background (on text and date/time labels)

(CA) Calibrations

The “CA” command assigns a calibration to a selected COMM port.

<Esc>(CA0pnn	Port “p” has calibration “nn” assigned to it p is a numeric value of 0-9 designating COMM ports 1-10 nn is a numeric value 1-10 designating calibrations 1-10
--------------	---

. Examples:

<Esc>(CA0004	Utilize Cal #4, Port 1
<Esc>(CA0505	Utilize Cal #5, Port 6
<Esc>(CA0806	Utilize Cal #6, Port 9

(CD) Calibration Types

The “CD” command activates a calibration procedure.

<Esc>(CDP	Activate USB PVI-PC20 calibration.
<Esc>(CDT	Activate Touchscreen calibration.
<Esc>(CDW	Activate Whiteboard calibration.

(CE) Color Enable

The “CE” command determines what colors are available from the color palette. Refer to the “CS” commands for how to change the color of a marker using this enabled palette.

<Esc>(CEB1	Enable Black
<Esc>(CEBØ	Disable Black
<Esc>(CEC1	Enable Cyan
<Esc>(CECØ	Disable Cyan
<Esc>(CEG1	Enable Green
<Esc>(CEGØ	Disable Green
<Esc>(CEHG1	Enable Green Highlight
<Esc>(CEHGØ	Disable Green Highlight
<Esc>(CEHP1	Enable Pink Highlight
<Esc>(CEHPØ	Disable Pink Highlight
<Esc>(CEHY1	Enable Yellow Highlight
<Esc>(CEHYØ	Disable Yellow Highlight
<Esc>(CEP1	Enable Pink
<Esc>(CEPØ	Disable Pink
<Esc>(CER1	Enable Red
<Esc>(CERØ	Disable Red
<Esc>(CEW1	Enable White
<Esc>(CEWØ	Disable White
<Esc>(CEY1	Enable Yellow
<Esc>(CEYØ	Disable Yellow

(CL) Clear

The “CL” command clears the markers from the video overlay.

<Esc>(CL	Clears All Markers
----------	--------------------

(CM) Marker Move

The “CM” command moves an active marker (pointer, frame, label or text or date/ time label) using the XY coordinate grid. (see *X-Y Coordinate Grid*, on page 108)
The coordinates are: XXXX = a numeric value for the horizontal axis point and
YYYY = a numeric value for the vertical axis point.

<Esc>(CMXXXXYYYY	Move an active marker to coordinates XXXX and YYYY Example: <Esc>(CM00250037
------------------	---

(CPF) Freeze

The “CPF” command freezes the current video image being displayed..

<Esc>(CPF0	Turns the freeze off (video is live)
<Esc>(CPF1	Activates the freeze
<Esc>(CPFT	Toggles the command from whatever is current

(CPI) Read Specific Image From USB

The “CPI” command reads an image from the USB flash drive. This command uses the current Directory and Prefix assigned for capturing images. The nnnnn part of the command also automatically sets the index number (See “Capture Options” on page 46).

<Esc>(CPInnnnn	Read the requested image from the USB location nnnnn is the index number of the image
----------------	--

(CPN) Read Specific Image From TFTP

The “CPN” command reads an image from the TFTP server. This command uses the current Directory and Prefix assigned for capturing images. The nnnnn part of the command also automatically sets the index number (See “Capture Options” on page 46).

<Esc>(CPNnnnnn	Read the requested image from the TFTP location nnnnn is the index number of the image
----------------	---

(CPP) Print Current Image

The “CPP” command prints the current image.

<Esc>(CPP	Print the current image
-----------	-------------------------

(CPRD) Read Current Image from USB

The “CPRD” command reads the current image from the USB flash drive based on the current file Capture settings (See “Capture Options” on page 46).

<Esc>(CPRD	Read the current image from the USB location
------------	--

(CPRS) Read Current Image from SMB

The “CPRS” command reads the current image from the SMB location based on the current file Capture settings (See “Capture Options” on page 46).

<Esc>(CPRS	Read the current image from the SMB location
------------	--

(CPRT) Read Current Image from TFTP

The “CPRT” command reads the current image from the TFTP location based on the current file Capture settings (See “Capture Options” on page 46).

<Esc>(CPRT	Read the current image from the TFTP location
------------	---

(CPSD) Store Current Image to USB

The “CPSD” command stores the current image to the USB flash drive based on the current file Capture settings (See “Capture Options” on page 46).

<Esc>(CPSD	Store the current image to the USB location
------------	---

(CPSS) Store Current Image to SMB

The “CPSS” command stores the current image to the current SMB destination (See “Capture Options” on page 46).

<Esc>(CPSS	Store the current image to the SMB location
------------	---

(CPST) Store Current Image to TFTP

The “CPST” command stores the current image to the current TFTP destination (See “Capture Options” on page 46).

<Esc>(CPST	Store the current image to the TFTP location
------------	--

(CPW) Read Specific Image From SMB

The “CPW” command reads an image from the SMB server. This command uses the current Computer and Share names assigned for capturing images. The nnnnn part of the command is the index number of the image you want to read.

<Esc>(CPWnnnnn	Read the requested image from the SMB location nnnnn is the index number of the image
----------------	--

(CS) Color Selection

The “CS” command handles color attributes of an active marker. These commands will force an “enable” of the color selected without having to enable that color using the “CE” commands or going to the Menu System.

<Esc>(CSB	Select Black
<Esc>(CSC	Select Cyan
<Esc>(CSD1	Display Color Change display a sample block of the new color. May be desired if a pointer is not being displayed. The option may not be desired if you wish to change colors during a live broadcast.
<Esc>(CSDØ	Do not display color change
<Esc>(CSDT	Toggle color change display
<Esc>(CSE	Select Previous Color
<Esc>(CSG	Select Green
<Esc>(CSHG	Select Green Highlight Color
<Esc>(CSHP	Select Pink Highlight Color
<Esc>(CSHY	Select Yellow Highlight Color
<Esc>(CSMH	Select Highlight Color Mode
<Esc>(CSMM	Select Multiplex Color Mode
<Esc>(CSMT	Toggle between color modes
<Esc>(CSN	<i>Select Next</i> get next available color (see “(CE) Color Enable” on p.101).
<Esc>(CSP	Select Pink
<Esc>(CSR	Select Red
<Esc>(CSW	Select White
<Esc>(CSY	Select Yellow

(DCT/DCA) Device Type COMM

The “DCT” and “DCA” commands help you control the recognition of device types connected to Pointmaker COMM ports. Normally, at startup, the initialization setting (autodetect) for each COMM port causes the Pointmaker to run through a list of procedures until it can determine the device type connected to each one. The DCT command allows you to limit the initialization process for a designated port to only look for a specified device. The DCA command allows you to activate initialization of a COMM port immediately, without having to restart the Pointmaker.

<Esc>(DCTptt	Port “p” has device type “tt” assigned to it p is a numeric value of 0-9 designating ports 1-10 tt is a numeric value designating the device type corresponding to the table below Example: <Esc>(DCT223
<Esc>(DCAp	Port “p” is to be initialized immediately p is a numeric value of 0-9 designating ports 1-10

NOTE: In the table below, “tt” is the two digit number assigned to the the device type.

tt	device type	description
00	Mouse	Microsoft mouse
01	Mouse 3	Microsoft plus (Logitech 3 button)
02	Mouse B	Microsoft Ballmouse
03	Mouse MS	Mouse Systems mouse
04	Mouse A	Air Mouse
05	Digitizer A	ACECAD Acecat II digitizer
06	Mouse A2	Air Mouse Generation II
07	Autodetect	No mouse detected
08	Touch Scr I	Elographics Intellitouch Touch Screen
09	Touch Scr A	Elographics Accutouch Touch Screen
10	Touch Scr M	Microtouch Touch Screen
11	Touch Scr K	Keytec Touch Screen TS-232-B
12	Touch Scr S	Symbios Touch Screen SYM93C2000
13	Touch Scr C	CalComp 1000 DrawingSlate III
14	Touch Scr D3	Dynapro SC3 Touch Wall

tt	device type	description
15	Touch Scr W	Wacom IV protocol (for PL-300 LCD Tablet)
16	Touch Scr B	Smart Technologies Smart Board
17	Touch Scr H	Hampshire TSHARC-12 Touch Screen Controler
18	Mouse F W	Interlink Electronics Freedom Writer
19	Touch Scr P	Smart Technologies Smart Board w/ PNP
20	Touch Scr D4	Dynapro SC4 Touch Controller
21	Skip	
23		Wacom Intuos 2 4 x 5
24		Genius Basypen 3 x 4
25		Magictouch Touch Screen
26		Fujitsu Touch Screen
27		Egalax
28		Irtouch
29		Gunze
30		Control port
31		Multiport port
32		PVI to PVI link
33		Codec port

(DL) Draw Line

The “DL” command draws a line using the XY coordinate grid (see “X-Y Coordinate Grid” on page 97). The first coordinate series XXXXYYYY is the beginning point of the drawn line, and the second series XXXXYYYY represents the end point of the drawn line.

<Esc>(DLXXXXYYYYXXXXYYYY	Draw a Line
--------------------------	-------------

(DP) Drop Marker

The “DP” command drops an active marker (pointer, frame, label or cursor) using the XY coordinate grid (see “X-Y Coordinate Grid” upage 97). The coordinates are: XXXX = a numeric value for the horizontal axis point and YYYY = a numeric value for the vertical axis point.

<Esc>(DPXXXXYYYY	Drop an active marker at coordinates XXXX and YYYY Example: <Esc>(DP00250037
------------------	---

(DUI/DUP) Device Type USB

The “DUI” and “DUP” commands help you assign a device type to whatever you connect to a USB port. Normally, when you plug something into the USB port, the Pointmaker reads the vendor and product ID from the devices. Then it scans its list of device types for that vendor and product ID. If it finds it in the list, it initializes the port for that device type.

The DUI command allows you to link a vendor and product ID to one of the device type codes listed below, so it will be recognized by the Pointmaker. The DUP command allows you to assign a USB port to one of the device types listed. This can be less reliable if someone makes a change in the USB chain causing the port number to change.

<Esc>(DUIvvvpppptt	Vendor number “vvvv” and Product ID “pppp” has device type “tt” assigned to it vvvv and pppp are four digit numeric values tt is a numeric value designating the device type corresponding to the table below Example: <Esc>(DUI2237002317
<Esc>(DUPpptt	Port “pp” is a numeric value of 0-14 designating ports 1-15 tt is a numeric value designating the device type corresponding to the table below Example: <Esc>(DUP0528

NOTE: In the table below, “tt” is the two digit number assigned to the the device type.

tt	device type	description
00	Detected	None detected
01	Mouse	Boot mouse

tt	device type	description
02	Superpen	UCLogic Superpen digitizing tablet
03	Graphire 6x8	Wacom Graphire 6x8 digitizing tablet
04	Graphire 4x5	Wacom Graphire 4x5 digitizing tablet
05	Intuos 6x8	Wacom Intuos 6x8 digitizing tablet
06	Intuos 4x5	Wacom Intuos 4x5 digitizing tablet
07	Hyperpen 6x8	Aiptek Hyperpen 6x8 digitizing tablet
08	Elotouch	Elotouch touch controller (smartset protocol)
09	TSHARC	Hampshire TSHARC touch controller*/
10	Dynapro SC4	Dynapro SC4 touch controller*/
11	3M EXII	3M EXII touch controller
12	Magic Touch	Keytec Magic Touch controller
13	Wacom PL	Wacom PL protocol touch panels
14	Sympodium	Smart Technologies sympodium switches
15	Keyboard	Basic keyboard
16	Hub	USB Hub
17	Printer	Basic printer
18	Smart Board1	Smart Technologies 1st USB cable
19	Fujitsu	Fujitsu touch controller
20	Smart Board2	Smart Technologies 2nd USB cable
21	Cintiq 21UX	Wacom Cintiq 21UX – also Intuos 3
22	Smart Bd SC9	Smart Technologies SC9 USB controller
23	EELY elTouch	EELY elTouch touch controller
24	3M SCxxx	3M Microtouch SCxxx Series touch controller
25	Intuos3 4x5	Wacom Intuos 3 4x5 digitizing tablet
26	Intuos3 6x8	Wacom Intuos 3 6x8 digitizing tablet
27	Intuos3 9x12	Wacom Intuos 3 9x12 digitizing tablet
28	Intuos3 12x12	Wacom Intuos 3 12x12 digitizing tablet
29	Intuos3 12x19	Wacom Intuos 3 12x19 digitizing tablet
30	Intuos3 6x11	Wacom Intuos 3 6x11 digitizing tablet
31	SCSI MSD	SCSI Mass Storage Device
32	Egalax	Egalax touch controller
33	NextWindow	NextWindow touch controller
34	NextWin Ctrl	NextWindow touch controller – control interface
35	Bamboo 4x6	Wacom Bamboo 4x6 digitizing tablet

tt	device type	description
36	BambooFun4x6	Wacom Bamboo Fun 4x6 digitizing tablet
37	BambooFun5x9	Wacom Bamboo Fun 5x9 digitizing tablet
38	Gyrati Mouse	Gyration Mouse
39	Gyration Kbd	Gyration Keyboard
40	SB Carrera	Smart Board Carrera
41	Promethean	Promethean
42	Quanta	Quanta Computer Optical Touch controller
43	Wacom DTU	Wacom DTU (e.g. DTU-2231) Graphire protocol
44	Quanta 2	Quanta 2 Computer
45	Panasonic	Panasonic Electronic Pen

(E) Echo

The “E” command tells the Pointmaker to echo the input over the RS-232 link, in full, in part or not at all.

<Esc>(EA	Echo all input
<Esc>(EC	Echo all except commands
<Esc>(EN	Disable echo
<Esc>(EO	Echo “OK” on command “OK <cr> <lf>”

(EM) Erase Method

The “EM” command activates your choice of erase methods.

<Esc>(EMØ	Erase Method: “UNDO”
<Esc>(EM1	Erase using Small eraser
<Esc>(EM2	Erase using Medium eraser
<Esc>(EM3	Erase using Large eraser

(ESP, ESA) Video Streaming (CPN-6000)

The “ESP” and “ESA” commands give you control over the video streaming features of the CPN-6000. The ESP setting is not applied until the ESA command is sent.

<Esc>(ESPØ	Video streaming off
<Esc>(ESP1	Video streaming on
<Esc>(ESPT	Video streaming toggle between the two settings
<Esc>(ESA	Apply the last “ESP” setting

(FS) Frame Size

The “FS” command defines an active frame.

<Esc>(FSXXXXYYYY	Designating the size of an active frame. XXXX = a numeric value for the horizontal dimension. YYYY = a numeric value for the vertical dimension. Units range from ØØØ1 to 2Ø48.
------------------	--

(FT) Frame Type

The “FT” command tells the Pointmaker which type of frame to display on-screen.

<Esc>(FTBØ	Box Frame
<Esc>(FTB1	Filled Box Frame
<Esc>(FTCØ	Circle Frame
<Esc>(FTC1	Filled Circle Frame
<Esc>(FTN	Next Frame

(HI) HDCP Input setting for each HDMI input port

The “HI” command designates which HDMI input ports will allow HDCP sources to be passed to the video outputs. See also the VIH command.

<Esc>(HIInØ	HDCP input is off for port “n”. “n” is a numeric value of 5-9 designating HDMI Input ports 5-9.
<Esc>(HIIn1	HDCP input is on for port “n”. “n” is a numeric value of 5-9 designating HDMI Input ports 5-9.
<Esc>(HIInT	Toggle between the two modes for port “n”. “n” is a numeric value of 5-9 designating HDMI Input ports 5-9.

(I) Marker Intensity or Brightness

The “I” command sets the intensity or brightness level for markers. Positive or negative values may be coded.

<Esc>(ISXXX	Set the brightness level (absolute). XXX is numeric value between 0 and 999.
<Esc>(ICXXX	Increases brightness level (relative). XXX is numeric value between 0 and 999.
<Esc>(IC-XXX	Decreases brightness level (relative). XXX is numeric value between 0 and 999.

(IFD) Set Image File Directory

The “IFD” command sets the directory for the image file to be saved.

<Esc>(IFDccc...	Set the file directory. ccc... is no more than 16 characters, terminated with a carriage return.
-----------------	--

(IFI) Set Image File Index

The “IFI” command sets the image file index, designating where the numbering of saved images will start.

<Esc>(IFInnnnn	Set the image file index. nnnnn is a five digit number. The combination of image file prefix and index must be equal to or less than 8 characters.
----------------	--

(IFP) Set Image File Prefix

The “IFP” command sets the image file prefix to be used for saved images.

<Esc>(IFPccc...	Set the image file prefix. ccc... is less than or equal to 3 characters, terminated with a carriage return. The combination of image file prefix and index must be equal to or less than 8 characters.
-----------------	--

(IM) Identify Mode for Multiple Users

The “IM” command designates the mode to use when multiple digitizing tablets or touch screens are installed. When PRIORITY USER mode is selected, you will also need to send the command designating which controller (COMM #) is the priority user.

<Esc>(IMO	Assigns Open Mode.
<Esc>(IMS	Assigns Selective Mode.
<Esc>(IMP	Assigns Priority User Mode.
<Esc>(IMCXX	Sets COMM port for Priority User. XX = the COMM port (01-10) The port selected should be connected to a digitizing tablet or touch screen.

(L) Line Style

The “L” command determines the line style to use when drawing a freehand line, straight line or frame.

<Esc>(LF	Fine or thin line.
<Esc>(LSF	Fine or thin line with drop shadow.
<Esc>(LM	Medium line.
<Esc>(LSM	Medium line with drop shadow.
<Esc>(LB	Bold line.
<Esc>(LSB	Bold line with drop shadow.
<Esc>(LW	Line style changes to wide.
<Esc>(LSW	Line style changes to wide with a shadow.
<Esc>(LP	Line style switches to the previous line style.
<Esc>(LN	Line style switches to the next line style.

(K) Keyboard Input

The “K” command allows for common keyboard actions.

<Esc>(Knn	where nn is a two-digit hexadecimal number
-----------	--

Some commonly used examples:

<Esc>(KC8	up arrow
<Esc>(KCB	left arrow
<Esc>(KCD	right arrow
<Esc>(KDØ	down arrow
<Esc>(KØD	Enter

(M) Video Input Type

The “M” commands tell the Pointmaker which type of video input is being used or switched to, so that the proper signal is output from the Pointmaker. All “M” commands override “A” (autodetect) commands.

RS-232 commands remain the same for each Pointmaker model, so models with identical features continue to function with no code change. With this unit, each “Video Input” port on the back panel is labeled with a unique number to simplify port locating and troubleshooting for the system integrator. Notes are included to clarify the correspondence to the new labels.

NOTE: Composite and Y/C are available but only at half their normal resolution.

<Esc>(MC1N	Composite 1 NTSC (labeled port 1 on rear panel)
<Esc>(MC2N	Composite 2 NTSC (labeled port 2 on rear panel)
<Esc>(MYN	Y/C NTSC (labeled port 3 and 4 on rear panel)
<Esc>(MV1	1st VGA port (labeled port 3 on rear panel)
<Esc>(MV2	2nd VGA port (labeled port 4 on rear panel)
<Esc>(MDA1	DVI-A1 (labeled port 3 on rear panel) Supports what was VGA control code from previous model. Functions identically to MV1.
<Esc>(MDA2	DVI-A2 (labeled port 4 on rear panel) Supports what was VGA control code from previous model. Functions identically to MV2.
<Esc>(MH1	1st HDMI port (labeled port 5 on rear panel)
<Esc>(MH2	2nd HDMI port (labeled port 6 on rear panel)
<Esc>(MH3	3rd HDMI port (labeled port 7 on rear panel)
<Esc>(MH4	4th HDMI port (labeled port 8 on rear panel)
<Esc>(MH5	5th HDMI port (labeled port 9 on rear panel)

(ME) Verify Dialog Response

The “ME” command allows you to respond to the “Verify” dialog.

<Esc>(MEØ	Responds “OK”
<Esc>(ME1	Responds “Retry”
<Esc>(ME2	Responds “Cancel”

(PA) Pass-through

The “PA” command enables the video image to “pass-through” the system without displaying the marker overlay.

<Esc>(PA1	Enable pass-through. (overlay is hidden)
<Esc>(PAØ	Disable pass-through. (overlay is displayed)
<Esc>(PAT	Toggle pass-through.

(PT) Pointer Type

The “PT” command controls the display of pointer types contained in the Pointmaker.

<Esc>(PTC	Displays Circle
<Esc>(PTDL	Display Down Left Arrow
<Esc>(PTDØ	Display Down Arrow
<Esc>(PTDR	Display Down Right Arrow
<Esc>(PTL	Display Left Arrow
<Esc>(PTN	Hide Pointer
<Esc>(PTP	Display Cross Hairs
<Esc>(PTR	Display Right Arrow
<Esc>(PTSC	Display Small Circle
<Esc>(PTSP	Display Small Cross Hairs
<Esc>(PTT1	Enable pointer toggle.
<Esc>(PTT2	Turn pointer off.
<Esc>(PTT3	Turn pointer on.
<Esc>(PTT4	Toggle pointer on/off.
<Esc>(PTT5	Display next pointer selects next pointer in the sequence.
<Esc>(PTTØ	Disable pointer toggle.
<Esc>(PTUL	Display Up Left Arrow
<Esc>(PTUØ	Display Up Arrow
<Esc>(PTUR	Display Up Right Arrow

(PX) Proximity On/Off

The “PX” command controls the pen proximity feature of digitizing tablets. When proximity is on, active pointers disappear when the pen is lifted from the drawing area. When proximity is off, active pointers remain on-screen when the pen is lifted.

<Esc>(PX1	Turn proximity on.
<Esc>(PXØ	Turn proximity off.
<Esc>(PXT	Toggle proximity.

(R) Restart Pointmaker

The “R” command restarts the Pointmaker. Options include saving current settings and markers in memory (a soft boot), or clearing memory of all settings and markers (a hard boot).

<Esc>(RS	Restart saving current settings and markers in memory.
<Esc>(RH	Restart clearing current settings and markers.

(S) Date/Time Marker

The “S” command controls options concerning the date/time marker. It displays as an active marker.

<Esc>(STØ	Displays date/time marker in time only mode.
<Esc>(SDØ	Displays date/time marker in date only mode.
<Esc>(SDT	Displays date/time marker in time only mode.
<Esc>(SDSMMDDYYYY	Set the date. M=month, D=Day, Y=year
<Esc>(STAHMM	Set time as a.m. H=hour, M=minute
<Esc>(STPHMM	Set time as p.m. H=hour, M=minute

(SCO) Scaler Output Format

The “SCO” command is used to set the scaler output to the desired format.

<Esc>(SCO <code>nn</code>	Setting “ <code>nn</code> ” is the numeric value taken from the table below to designate the format to be output by the scaler Example: <Esc>(SCO09
---------------------------	--

640 x 480 @ 60 Hz	00
640 x 480 @ 72 Hz	01
640 x 480 @ 75 Hz	02
640 x 480 @ 85 Hz	03
800 x 600 @ 56 Hz	04
800 x 600 @ 60 Hz	05
800 x 600 @ 72 Hz	06
800 x 600 @ 75 Hz	07
800 x 600 @ 85 Hz	08
1024 x 768 @ 60 Hz	09
1024 x 768 @ 70 Hz	10
1024 x 768 @ 72 Hz	11
1024 x 768 @ 75 Hz	12
1024 x 768 @ 85 Hz	13
1280 x 1024 @ 60 Hz	14
1280 x 1024 @ 72 Hz	15
1280 x 1024 @ 75 Hz	16
1280 x 720P @ 60 Hz	17
1920 x 1080P @ 60 Hz	18
1280 x 800 @ 60 Hz	19
1440 x 900 @ 60 Hz	20
1680 x 1050 @ 60 Hz	21
1400 x 1050 @ 50 Hz	22
1400 x 1050 @ 60 Hz	23

(SUM) Menu System

The “SUM” command displays the Main Menu.

<Esc>(SUM	Activate the menu system.
-----------	---------------------------

(T) Text Label

The “T” command controls active text labels. Labels can be composed of single characters or text blocks. This command also allows you to set font and size.

<Esc>(TTc	Displays any single character. “c” is any displayable character.
<Esc>(TBccc...	Displays a block of characters. “ccc...” is however many displayable characters you choose to display - limited by screen display area.

Font selection commands can be assigned to the active text label after it is visible on the screen.

<Esc>(TFØ	Change font to TI Roman.
<Esc>(TF1	Change font to Helvetica.
<Esc>(TF2	Change font to TI Dom Casual.
<Esc>(TF3	Change font to Fargo.
<Esc>(TF4	Change font to Symbol.
<Esc>(TF5	Change font to Map.
<Esc>(TN	Change to the next font.
<Esc>(TP	Change to the previous font.

Font size commands can be assigned to the active text label after it is visible on the screen:

<Esc>(TSØ	Small works with: TI Roman, Helvetica, TI Dom Casual, Fargo, Symbol, Map
-----------	---

<Esc>(TS1	Medium works with: TI Roman, Helvetica, TI Dom Casual, Fargo
<Esc>(TS2	Large works with: TI Roman, Helvetica, TI Dom Casual, Fargo
<Esc>(TS3	Extra Large works with: TI Roman, Helvetica, TI Dom Casual

(TA) Template Change

The “TA” command designates which template layout is activated for use with the digitizing tablet.

<Esc>(TAØ	Presenter template.
<Esc>(TA1	Broadcaster template.
<Esc>(TA2	PC template.

(TC) Touch Screen Corner Control

The “TC” commands tell the Pointmaker to enable or disable the corner function areas on a touch screen (see “Function Areas” on page 10).

<Esc>(TCØ	Disable corner function areas
<Esc>(TC1	Enable corner function areas
<Esc>(TC2	Toggle corner function areas

(TCA) Touch Screen Function Areas

The “TCA” commands tell the Pointmaker which commands are assigned to the seven touch screen function areas (see “Function Areas” on page 10).

<Esc>(TCAnnxx	Setting “nn” is the numeric value taken from the table below which designates the position each touch screen area Setting “xx” is the numeric value taken from the second table below which designates the function assigned to the area Example: <Esc>(TCA0309 <i>(middle-right, get image)</i>
---------------	--

nn	touch screen area
00	top-left
01	top-center
02	top-right
03	middle-right
04	bottom-right
05	bottom-center
06	bottom-left
07	middle-left

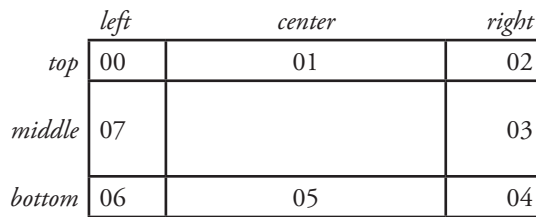

Figure 6-1: Touch screen areas location diagram

xx	function
00	none
01	clear
02	undo
03	next color
04	freeze / unfreeze

xx	function
05	print
06	color mode
07	save image
08	send image
09	get image
10	select (for PC connection)
11	main menu
12	next video
13	previous video
14	video input selection

(TR) Touch Screen Right Click Emulation

The “TR” commands tell the Pointmaker to enable or disable the right click emulation.

<Esc>(TRØ	Disable touchscreen right click emulation
<Esc>(TR1	Enable touchscreen right click emulation
<Esc>(TRT	Toggle touchscreen right click emulation

(U) Undo/Erase

The “U” command erases the last created anchored marker. Each time this command is given, an anchored marker will be erased from the overlay, beginning with the most recently anchored marker.

<Esc>(U	Undo the last anchored marker.
---------	--------------------------------

(V) Select an Overlay

The “V” command tells the Pointmaker which overlay to display.

<Esc>(V#	Display overlay number specified. replace # with overlay number desired.
<Esc>(VN	Display next overlay.
<Esc>(VP	Display previous overlay.

NOTE: To hide the overlay, see the Pass-through (PA) command.

(VCD) Display Change of Video Input

The “VCD” command tells the Pointmaker whether to display a change of video input on the monitor.

<Esc>(VCDØ	Do not display a change in the video input
<Esc>(VCD1	Display a change in the video input
<Esc>(VCDT	Toggle between the two modes

(VI) Video Input

The “VI” command tells the Pointmaker to move forward or backward in choosing a video input.

<Esc>(VIN	Next video input
<Esc>(VIP	Previous video input

(VIH) Enable or Disable HDCP Input

The “VIH” is a master switch for handling HDCP Input throughout the Pointmaker. If it is turned off, no HDCP content can pass through the Pointmaker. If it is turned on, HDCP sources are handled according to your current “HI” settings.

<Esc>(VIHØ	HDCP input is off
<Esc>(VIH1	HDCP input is on
<Esc>(VIHT	Toggle between the two modes

(VSW) Initiate Wait Before Video Switching

The “VSW” command tells the Pointmaker to black the video output for two seconds or until a video switch has completed. The Pointmaker will black the video output so the user does not see any video artifacts when the switcher makes the video switch. This means the switcher has two seconds in which to make this switch before the Pointmaker will display video again. The user should have a wait of 200ms to 500ms between sending the video switch wait command to the Pointmaker and sending the switch command to the switcher. This wait is necessary to ensure that the Pointmaker has seen the command and blacked out the video before the switcher has started the video switch.

<Esc>(VSW	Initiates Video Switch Wait for two seconds.
-----------	--

APPENDIX

TROUBLESHOOTING GUIDE

Pointmaker's quality inspectors test each product prior to shipment. Therefore, most problems that presenters encounter are related to installation. The following table describes common problems and their solutions. If, after referring to this table, a problem still exists, call Pointmaker LLC., at (800) 552-2262 or (520) 745-0001 and ask for technical assistance. There are no user serviceable parts in the Pointmaker. Do not open the cabinet.

Special Note: The Pointmaker can be returned to factory default settings by pressing CTRL + ALT + END.

WARNING: executing this command will erase all user settings including calibrations, COMM port settings, etc.

Soft boot: CTRL-ALT-DEL is the same as cycling power

Symptoms	Possible Solutions
The green indicator light on the front of the Pointmaker does not light up.	1. Check that the Pointmaker is plugged into a live outlet.
Monitor does not light up.	<ol style="list-style-type: none"> 1. Check that the monitor is plugged into a live outlet. 2. Check that the monitor is switched on. 3. Check that the monitor brightness and contrast controls are properly adjusted.
The Pointmaker markers appear to bloom.	<ol style="list-style-type: none"> 1. Adjust system parameters on the video output device, monitor, or camera (if in use) such as contrast, gain, brightness, color, light, and intensity. 2. Decrease brightness of Pointmaker markers or use a different marker color.
Monitor lights up but does not display a picture.	<ol style="list-style-type: none"> 1. Check that the video source and Pointmaker are each plugged into a live outlet. 2. Check that the video source and Pointmaker are both switched on. 3. Check that the proper cables are connected to the proper connectors on the video source, the Pointmaker, and the monitor. Some sources and monitors have multiple output and input connectors. Consult your video or computer manuals for correct connection information. 4. Bypass the Pointmaker by connecting the monitor directly to the video source. If the video image still does not appear, have the video source and monitor checked.

Symptoms	Possible Solutions
Monitor automatically adjusts brightness so that video image is dull while markers are bright.	Monitor is automatically adjusting for the overall brightness level of the markers and the video image. On the Pointmaker, activate the Change Brightness command (see "Selecting a Brightness Level" on page 33). Tone down the brightness level of the markers. The monitor will adjust accordingly.
Video image on monitor scrolls.	If using RGB input, ensure that the Pointmaker horizontal and vertical sync connectors are also being used or that the RGB source is composite sync.
Monitor displays a scrambled picture.	<ol style="list-style-type: none"> 1. Check the horizontal hold control on the video monitor for proper adjustment. 2. Check that the Dual Voltage Switch (110V/220V) located on the back panel of the Pointmaker is properly set. 3. Monitor is not compatible with video source. Use compatible system. 4. Check to be sure that the video in and out connectors on the Pointmaker are secure. 5. If there is no RGB or RGB H/V input to the Pointmaker (that is, there is output only), the Pointmaker will automatically assume that a 15.75 kHz signal output is desired. If another signal is desired, then input a video source that will output the desired frequency.
Digitizing tablet, mouse device will not operate properly.	Refer to the specific section in this manual that describes installation of your controller (see <i>Connecting Controllers</i> on page 18. Also refer to the tablet manufacturer's operating instructions.
Touch screen will not operate properly.	For touch screens, you may need to calibrate from the copyright message (see "Calibrating CR-100 Controllers" on page 47).
PC display scrolls.	<p>You may need to adjust your computer's Display or Monitor Type setting for a video scan rate compatible with the Pointmaker.</p> <p>For display utilities that permit the user to change the horizontal scan rate or vertical refresh rate: Select a resolution, maximum horizontal scan rate, and a maximum vertical scan rate that are compatible with the computer hardware, the Pointmaker, and the display monitor/projector. You will need to restart the computer before changes can be activated.</p> <p>For Windows 95/98/2000 Display Settings that permit a change in monitor type:</p> <p>If an independent display utility or video driver was not installed, you may want to change the display type by using the settings commands that came with Windows 95/98/2000.</p> <ol style="list-style-type: none"> 1. Select START < SETTINGS < CONTROL PANEL < DISP LAY. 2. In the Display Properties window, click on the Settings tab. 3. Select the Change Display Type button. 4. In the Manufacturers window, select Standard Monitor. <ol style="list-style-type: none"> A) For SVGA: Under "model," choose Super VGA with a resolution that is compatible with the computer hardware, the Pointmaker, and the display monitor/projector. 5. Once selections are complete, return to the Settings Menu and click Apply. You will need to restart the computer before changes can be activated.

UPDATING THE CR-100

The CR-100 firmware can be updated through USB or TFTP to provide new features, improved functionality or bug fixes.

Before activating the Update command, the update file (A002476.BIN) must be copied into a directory called BIIUPG. Create this directory directly under the Root directory. This setup can be done using either a USB flash drive or TFTP.

1. **Activate the menu system** (see *Activating the Menu*, on page 27).

The Main Menu appears.

2. **Select UPDATE.**

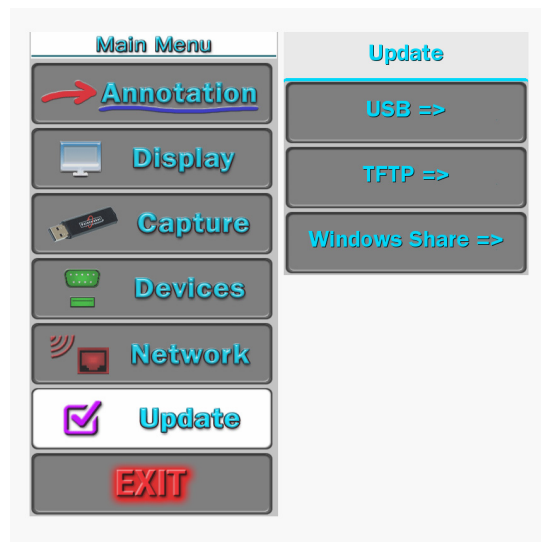

Figure 7-1: Update dialog

The Update dialog appears.

3. **Select USB or TFTP, depending on where you have placed the update file.**

The screen will display various information as the update takes place. Then it will request that you cycle the power.

4. **Turn the CR-100 off, then turn it back on.**

The system will start up using the new firmware.

QUICK REFERENCE FOR DEVICES

This section contains tables for quick reference to the device commands for the CR-100. Tables are arranged alphabetically by function.

The list below outlines the devices covered in this section.

- DTU-30 Digitizing Tablet
- Touch Screen / Whiteboard
- KB-30 Keyboard
- Mouse Devices

Quick Reference for Digitizing Tablet

The commands in the table following this sample template are for the DTU-30 digitizing tablet when used with the Pointmaker CR-100. The template design is updated periodically. Yours may not look exactly the same. If a function you want is not listed in this table, then you must select that function in the menu system.

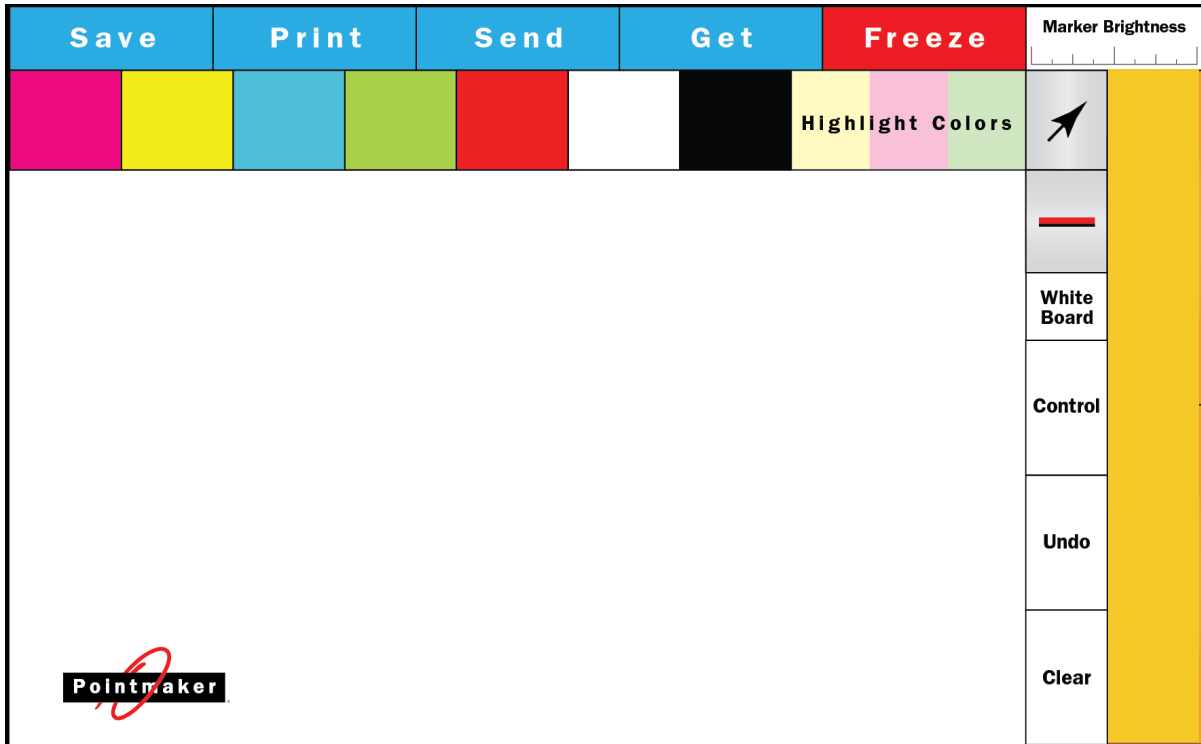

COMMAND	OPERATION
Anchor a Marker	Click Barrel Button when marker is in desired position.
Brightness, Change	(Presenter Template only) Click pen tip on brightness scale, left
Chalkboard Mode	Click pen tip on Chalkboard icon. To return to Video Source background, click on Video icon. This option is not available on Broadcaster template.
Clear Markers	Click pen tip on Clear icon.
Color, Change Marker	Click Tip Button on Menu Strip icon; in menu system, click tip button while cursor is over desired option.
Control	Click Tip Button on Control icon to take control when multiple tablets (or touch screens) are installed and you have activated Selective or Priority User mode in the menu system.
Draw	Press Tip Button anywhere on Tracking Area of tablet and drag.
Line Thickness, Change	Click pen tip on icon displaying desired line thickness.
Pen Proximity	(Broadcaster Template only) Click pen tip on Pen Proximity icon to turn this feature on or off. When activated, the active pointer disappears as the pen tip is pulled away from the screen. The pointer reappears when the pen tip is brought close again to the screen.
Point	Lightly drag Tip Button across Tracking Area to position pointer. To keep pointer positionable, do not click or press any stylus button.
Pointer Selection	Broadcast Template: Click the pen tip on the pointer you desire. Presenter Template: Click the pen tip on pointer icon. A panel of pointers will appear for you to select from.
Undo/Erase Marker	Click pen tip on Undo icon. If Erase Mode is activated in the menu system, this command activates Erase Mode instead of undoing a marker.
Video Mode, Change	Click pen tip on icon displaying desired video format, for example, HDMI or VGA.
Menu System, Access	(Operational only when keyboard not installed.) Press Barrel Button, then Tip Button, pressing both together for about 5 seconds.
Image Functions: Commands to utilize marked video images. The barrel button must be depressed as the button is selected.	
Save	This button saves a copy of whatever image is displayed on your monitor, to a USB memory device, at the moment the button is selected. A counter will appear in the bottom right corner of the screen, indicating the percentage of the image currently saved. You must wait until the counter disappears before starting a new save. The naming and location settings for saving images are found in the menu system.
Print	This button prints a copy of whatever image is displayed on your monitor at the moment the button is selected. A counter will appear in the bottom right corner of the screen, indicating the percentage of the image currently sent to the printer. You must wait until the counter disappears before starting a new print.
Send	This button sends a copy of whatever image is displayed on your monitor, to a specified network location, at the moment the button is selected. A counter will appear in the bottom right corner of the screen, indicating the percentage of the image currently sent to the location. You must wait until the counter disappears before starting a new send.

COMMAND	OPERATION
Get	This button allows you to retrieve an image that has been saved on your USB memory device. When it is selected, a menu dialog will appear, allowing you to specify which image you desire. The image will then be displayed on your monitor. A counter will appear in the bottom right corner of the screen, indicating the percentage of the image currently being retrieved. Then the image will be displayed. You can return to a desired video input by selecting the appropriate button. You must wait until the counter disappears before starting a new "get" command.

Quick Reference for Keyboard

The commands in these tables are for the KB-30 keyboard when used with the Pointmaker CR-100.

MARKING COMMAND	KEY
Date/Time Display	[F8]
Date/Time Setup	Ctrl + [F8]
Font Selection for Text Labels (typed text)	[F6]
Font Size for Text Labels (typed text)	Ctrl + F6
Frame Selection (circular or boxlike)	[F3]
Frame Sizing Activation	[F4]
Frame Sizing Keys	Positioning Keys
Line Style Selection	[F2]
Pointer Selection	[F1]
Pointer (Active) On/Off	Ctrl + [F1]
Straight Line Draw	[F5]
Text Labels (typed text)	AlphaNumeric Keys
Text Background On/Off	[F7]

ACTION (OPS) COMMAND	KEY
Active Marker On/Off	[Home]
Anchor Marker	Insert [Drop]
Change Brightness	[F10]
Chalkboard On/Off	[F11]
Clear All Markers	Clear [End]
Color Change of Active Marker	[F9]
Delete a Marker (undo)	Undo [Delete]
Freeze Video Image	Alt + F1
Get Image	Alt + F3
Next Overlay	[Page Down]
Overlay of Markers On/Off	[F12]
Overlay, Go to #	[Scroll Lock]
Positioning Marker or Cursor	Positioning Keys
Positioning Marker, Fine Control	Ctrl + Posit. Key
Previous Overlay	[Page Up]
Print Image	Alt + F4
Recall Settings: at boot-up copyright screen:	Ctrl + Alt + Page Down(on Num Pad)

ACTION (OPS) COMMAND	KEY
Reverse Toggle Order	Shift + Function Key
Save Image	Alt + F2
Save Settings: at boot-up copyright screen:	Ctrl + Alt + Enter(on Num Pad)
Select	[Enter] or [Drop]
Send Image	Alt + F5
Menu System	[Print Screen]
Video In Composite	Ctrl + [F11]
Video In Y/C	Ctrl + [F12]

Quick Reference for Touch Screens and Whiteboards

The commands in this table are for a compatible touch screen or whiteboard, when used with the Pointmaker CR-100. If a function you want is not listed in this table, then you must select that function on the digitizing tablet or in the menu system.

COMMAND	OPERATION
Anchor a Marker	Quickly tap screen where you want the marker anchored.
Clear Markers	Tap lower left corner. All markers are cleared from the screen.
Color, Change	Tap top left corner. The marker color is changed to the next color activated in the Color Palette.
Draw	Press and drag finger.
Freeze Video	Tap top-right corner. A frame of running video is grabbed and displayed. Tap same spot again to return to video.
Point	Lightly drag finger across Tracking Area to position pointer. To keep pointer positionable, do not tap or press.
Print Screen Image	Tap the right-center area on the screen. The current image is sent to the printer.
Save Screen Image	Tap the left-center area on the screen. The current image is saved to the USB storage device.
Send Screen Image	Tap the bottom-center area on the screen. The current image is sent to the printer.
Undo/Erase Marker	Tap upper right corner. Activates either undo or erase command, depending on which mode has been chosen in the menu system.
Menu System, Access	Tap top center area. Pointmaker menu system is activated. (Operational only when keyboard not installed.)

Quick Reference for Other Mouse Devices

The commands in this table are for a compatible mouse device when used with the Pointmaker CR-100. If a function you want is not listed in this table, then you must select that function on the digitizing tablet or in the menu system.

COMMAND	OPERATION
Anchor a Marker	Click the Left (First) Button.
Clear Markers	Press Right (Second) Button.
Color, Change Marker	Press Right (Second) Button, then click Left (First) Button. Each click cycles to another color in the Color Palette.
Draw	Press Left (First) Button and draw while pressing.
Point	Lightly drag mouse across pad to position pointer. To keep pointer positionable, do not click or press any button.
Menu System, Access	(Operational only when keyboard not installed.) Press Right (Second) Button, then Left (First) Button, pressing both together for about 5 seconds.
Undo/Erase a Marker	Click Right (Second) Button. If Erase Mode is activated in the menu system, this command activates Erase Mode instead of undoing a marker.

SYMBOL FONT CHART

→ ← ↑ ↓ ↖ ↗ ↘ ↙ ⇨ ⇩ ⇧ ⇩
 a b c d e f g h i j k l

↩ ↪ ↪ ↩ ↪ ↩ ↩ ↪ ↩ ↪ ↩ ↪ ↩ ↪ ↩ ↪
 m n o p q r s t u v w x

○ ◦ ⇄ ⇅ ⇆ ⇇ ⇈ ⇉ ⇊ ⇋ ⇌
 y z A B C D E F G H I J

↖ ↗ ↘ ↙ ⇄ ⇅ ⇆ ⇇ ⇈ ⇉ ⇊ ⇋ ⇌
 K L M N O P Q R S T U V

⇄ ⇅ ⇆ ⇇ ⇈ ⇉ ⇊ ⇋ ⇌
 W X Y Z

🇺🇸 ① ② ③ ④ ⑤ ⑥ ⑦ ⑧ ⑨ ⑩
 ` 1 2 3 4 5 6 7 8 9 0

↻ ↺ ↻ ↺ ↻ ↺ ↻ ↺ ↻ ↺ ↻ ↺ ↻ ↺ ↻ ↺
 - = [] \ ; ' , . /

⇧ ♂ 📠 📞 📄 ✍️ ↘ ✉️ 📧 📧
 ~ ! @ # \$ % ^ & * ()

🇺🇸 🇺🇸 ⚡ ⇄ ⇅ ⇆ ⇇ ⇈ ⇉ ⇊ ⇋ ⇌
 _ + { } | : " < > ?

MAP FONT CHART

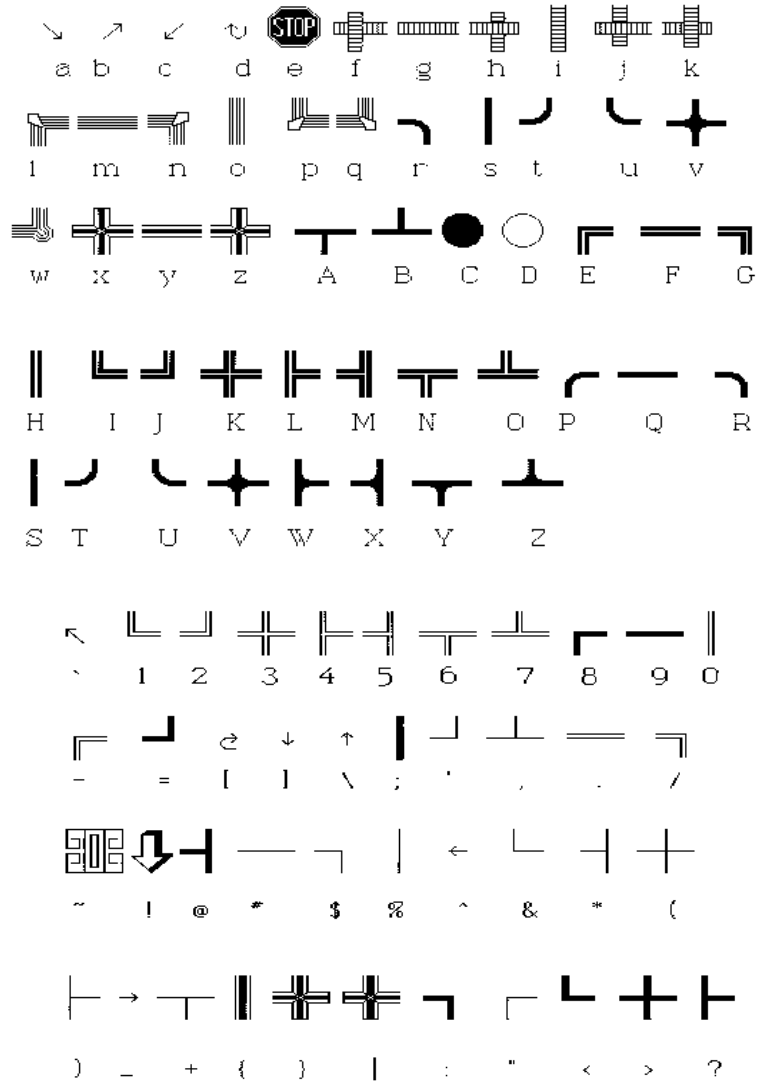

RS-232 (COMM PORT) PINOUT

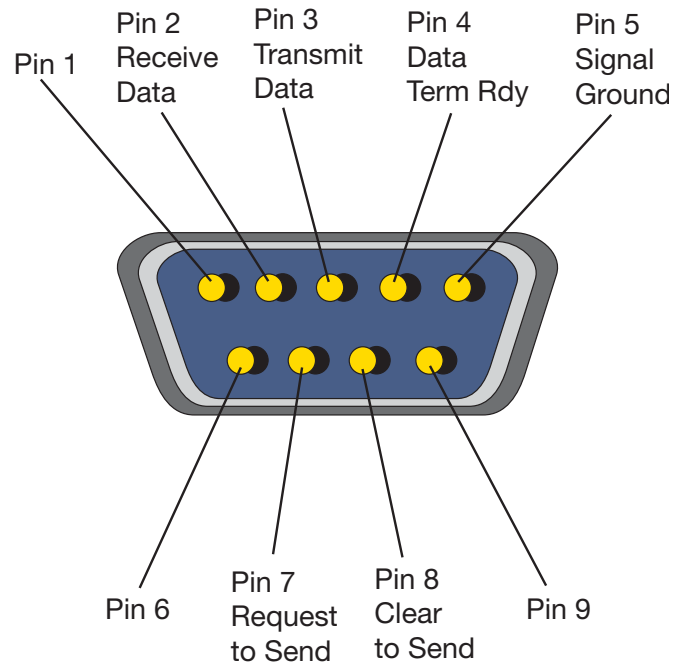

Figure 7-2: RS-232 COMM Port Pinout

GLOSSARY

ACTIVE MARKER

-- the pointer, frame, text label or date/time label which is positionable. Often used as a marker, but also used to position the starting point of a drawing line. When the active marker is anchored, another identical active marker appears on-screen. One active marker is always displayed, unless the marker has been turned off.

ANCHORED MARKER

-- the opposite of an active marker. An anchored marker has been placed in a fixed position on the Pointmaker overlay and cannot be moved again. However, anchored markers may be erased or cleared.

BACKGROUND

-- text background refers to the area immediately surrounding a line of text or a text label. For video background, see Chalkboard.

BLOOM

-- markers or text which enlarge or blur on the monitor due to excessive brightness.

BUTTON/ICON, TABLET

-- the square or rectangular zone on the tablet Menu Strip that represents a Pointmaker function. When this zone is clicked on with the pen tip, that function is engaged.

CHALKBOARD

-- the solid area behind the Pointmaker markers when in the Chalkboard mode. Presenters may choose a source background or a solid background.

CLEAR

-- the Pointmaker function that allows you to clear the overlay of all markers at once. A single active marker will remain on-screen unless the marker has been disabled.

CLICK

-- the action of quickly depressing and releasing a button on the Pointmaker auxiliary controller, as opposed to a press of the button.

COLOR PALETTE

-- a user-defined group of colors which may be attributed to each active marker before anchored. From 1 to 7 colors are available.

COMM PORT

-- a serial port used for communications. Serial devices that connect to these ports (such as a mouse or touch screen), send and receive data in single bits of information one after the other, thus the term serial.

CONNECTOR

-- hardware installed on cable ends to provide cable attachment to an input or output device. Input and output device ports which mate with this hardware are also called connectors.

CONTROLLER

-- a device that controls the selection, positioning, anchoring and clearing of markers on the Pointmaker overlay. Some other compatible controllers are most touch screens and certain mouse devices.

DRAW

-- the Pointmaker feature which allows presenters to freehand draw or write over a video or computer image.

DROP SHADOW

-- the Pointmaker option which allows presenters to attribute a shadow to drawing lines, frames or straight lines for the purpose of creating a line that stands out from the video image. Most colors have a black drop shadow. Black has no drop shadow.

EIA RS-170

-- the specifications describing monochrome electrical performance standards issued by the Electronic Industries Association (EIA). Also referred to as RS-170 (Recommended Standard). The EIA standard is used in North and South America, Japan and most of Asia.

ERASE -- the function that allows you to erase markers from the overlay, rather than undo them using a SMART board eraser or an onscreen "eraser." Erasing has the same effect as erasing with a pencil or chalkboard eraser; only the markers you touch (or parts of them) will erase.

FONT

-- a particular style of text such as Helvetica or Times Roman. The six (6) fonts installed in the Pointmaker are available in one or more sizes.

FRAME

-- the marker used to frame an image with a sizeable box or circle (available only on the keyboard model). Filled frames are also available and would be used to block out certain areas of the image.

ICON/BUTTON, TABLET

-- see button/icon.

MARKERS

-- pointers (arrows, cross hairs, dots), frames, date/time labels, freehand drawings and straight lines which can be placed and anchored on a Pointmaker marker overlay.

NTSC

-- the commonly accepted term describing the composite color version of the EIA RS-170 video standard. The color version of EIA RS-170 is in process of standardization by the Electronics Industries Association (EIA). NTSC is used in North and South America, Japan and most of Asia.

OVERLAY

-- a combination of one or more markers placed on the screen using the capabilities of the Pointmaker. These markers overlay a chosen video image. While the markers are visible, the actual overlay is invisible, allowing you to mark directly on top of a video image (or solid background if selected in the menu system).

POINTERS

-- the 8 different arrows, 2 cross hairs and 2 dot pointers which may be selected and placed on a Pointmaker overlay, in any number and in combination with other markers. Pointers are considered markers. However, not all markers (such as frames) are pointers.

PRESS

-- on the keyboard, the action of pressing then releasing the function key. On auxiliary controllers, a press is often the action of depressing and not releasing a button until the desired effect takes place on the screen (as opposed to a click of the button).

PROXIMITY

-- a feature of the CR-100 that affects the digitizing tablet. When proximity is activated, the active pointer automatically disappears each time the pen is lifted from the drawing area.

UNDO

-- the Pointmaker function that allows you to undo anchored markers on an overlay one at a time, beginning with the most recently anchored marker.

VIDEO SOURCE

-- a device from which the Pointmaker receives a video image, incorporates the Pointmaker graphic overlay capabilities, then outputs to the corresponding display. Examples of video sources include VHS recorder/players, cameras, VGA computers, standard television sets, teleconference equipment, slide-to-video converters, visual presenters and more. In the CR-100 model, the source is always HDMI.

OUTSIDE COPYRIGHT INFORMATION FOR SOFTWARE INCLUDED WITH THE CR-100.

(1) University of California, Berkeley

[1a]

Copyright (c) 1990 The Regents of the University of California.
All rights reserved.

Redistribution and use in source and binary forms are permitted provided that the above copyright notice and this paragraph are duplicated in all such forms and that any documentation, and other materials related to such distribution and use acknowledge that the software was developed by the University of California, Berkeley. The name of the University may not be used to endorse or promote products derived from this software without specific prior written permission. THIS SOFTWARE IS PROVIDED ``AS IS'' AND WITHOUT ANY EXPRESS OR IMPLIED WARRANTIES, INCLUDING, WITHOUT LIMITATION, THE IMPLIED WARRANTIES OF MERCHANTABILITY AND FITNESS FOR A PARTICULAR PURPOSE.

[1b]

Copyright (c) 1990 The Regents of the University of California.
All rights reserved.

Redistribution and use in source and binary forms are permitted provided that the above copyright notice and this paragraph are duplicated in all such forms and that any documentation, advertising materials, and other materials related to such distribution and use acknowledge that the software was developed by the University of California, Berkeley. The name of the University may not be used to endorse or promote products derived from this software without specific prior written permission. THIS SOFTWARE IS PROVIDED ``AS IS'' AND WITHOUT ANY EXPRESS OR IMPLIED WARRANTIES, INCLUDING, WITHOUT LIMITATION, THE IMPLIED WARRANTIES OF MERCHANTABILITY AND FITNESS FOR A PARTICULAR PURPOSE.

[1c]

Copyright (c) 1981, 1983, 1986, 1988, 1989, 1991, 1992, 1993, 1994
The Regents of the University of California.
All rights reserved.

Redistribution and use in source and binary forms, with or without modification, are permitted provided that the following conditions are met:

1. Redistributions of source code must retain the above copyright notice, this list of conditions and the following disclaimer.
2. Redistributions in binary form must reproduce the above copyright notice, this list of conditions and the following disclaimer in the documentation and/or other materials provided with the distribution.
3. Neither the name of the University nor the names of its contributors may be used to endorse or promote products derived from this software without specific prior written permission.

THIS SOFTWARE IS PROVIDED BY THE REGENTS AND CONTRIBUTORS ``AS IS'' AND ANY EXPRESS OR IMPLIED WARRANTIES, INCLUDING, BUT NOT LIMITED TO, THE IMPLIED WARRANTIES OF MERCHANTABILITY AND FITNESS FOR A PARTICULAR PURPOSE

ARE DISCLAIMED. IN NO EVENT SHALL THE REGENTS OR CONTRIBUTORS BE LIABLE FOR ANY DIRECT, INDIRECT, INCIDENTAL, SPECIAL, EXEMPLARY, OR CONSEQUENTIAL DAMAGES (INCLUDING, BUT NOT LIMITED TO, PROCUREMENT OF SUBSTITUTE GOODS OR SERVICES; LOSS OF USE, DATA, OR PROFITS; OR BUSINESS INTERRUPTION) HOWEVER CAUSED AND ON ANY THEORY OF LIABILITY, WHETHER IN CONTRACT, STRICT LIABILITY, OR TORT (INCLUDING NEGLIGENCE OR OTHERWISE) ARISING IN ANY WAY OUT OF THE USE OF THIS SOFTWARE, EVEN IF ADVISED OF THE POSSIBILITY OF SUCH DAMAGE.

[1d]

Copyright (c) 1988, 1990, 1993 Regents of the University of California.
All rights reserved.

Redistribution and use in source and binary forms, with or without modification, are permitted provided that the following conditions are met:

1. Redistributions of source code must retain the above copyright notice, this list of conditions and the following disclaimer.
2. Redistributions in binary form must reproduce the above copyright notice, this list of conditions and the following disclaimer in the documentation and/or other materials provided with the distribution.
3. Neither the name of the University nor the names of its contributors may be used to endorse or promote products derived from this software without specific prior written permission.

THIS SOFTWARE IS PROVIDED BY THE REGENTS AND CONTRIBUTORS "AS IS" AND ANY EXPRESS OR IMPLIED WARRANTIES, INCLUDING, BUT NOT LIMITED TO, THE IMPLIED WARRANTIES OF MERCHANTABILITY AND FITNESS FOR A PARTICULAR PURPOSE ARE DISCLAIMED. IN NO EVENT SHALL THE REGENTS OR CONTRIBUTORS BE LIABLE FOR ANY DIRECT, INDIRECT, INCIDENTAL, SPECIAL, EXEMPLARY, OR CONSEQUENTIAL DAMAGES (INCLUDING, BUT NOT LIMITED TO, PROCUREMENT OF SUBSTITUTE GOODS OR SERVICES; LOSS OF USE, DATA, OR PROFITS; OR BUSINESS INTERRUPTION) HOWEVER CAUSED AND ON ANY THEORY OF LIABILITY, WHETHER IN CONTRACT, STRICT LIABILITY, OR TORT (INCLUDING NEGLIGENCE OR OTHERWISE) ARISING IN ANY WAY OUT OF THE USE OF THIS SOFTWARE, EVEN IF ADVISED OF THE POSSIBILITY OF SUCH DAMAGE.

[1e]

Copyright (c) 1982, 1986, 1989, 1991, 1993, 1994
The Regents of the University of California. All rights reserved.
(c) UNIX System Laboratories, Inc.

All or some portions of this file are derived from material licensed to the University of California by American Telephone and Telegraph Co. or Unix System Laboratories, Inc. and are reproduced herein with the permission of UNIX System Laboratories, Inc.

Redistribution and use in source and binary forms, with or without modification, are permitted provided that the following conditions are met:

1. Redistributions of source code must retain the above copyright notice, this list of conditions and the following disclaimer.
2. Redistributions in binary form must reproduce the above copyright notice, this list of conditions and the following disclaimer in the documentation and/or other materials provided with the distribution.
3. Neither the name of the University nor the names of its contributors may be used to endorse or promote products derived from this software without specific prior written permission.

THIS SOFTWARE IS PROVIDED BY THE REGENTS AND CONTRIBUTORS "AS IS" AND ANY EXPRESS OR IMPLIED WARRANTIES, INCLUDING, BUT NOT LIMITED TO, THE IMPLIED WARRANTIES OF MERCHANTABILITY AND FITNESS FOR A PARTICULAR PURPOSE ARE DISCLAIMED. IN NO EVENT SHALL THE REGENTS OR CONTRIBUTORS BE LIABLE FOR ANY DIRECT, INDIRECT, INCIDENTAL, SPECIAL, EXEMPLARY, OR CONSEQUENTIAL DAMAGES (INCLUDING, BUT NOT LIMITED TO, PROCUREMENT OF SUBSTITUTE GOODS OR SERVICES; LOSS OF USE, DATA, OR PROFITS; OR BUSINESS INTERRUPTION) HOWEVER CAUSED AND ON ANY THEORY OF LIABILITY, WHETHER IN CONTRACT, STRICT LIABILITY, OR TORT (INCLUDING NEGLIGENCE OR OTHERWISE) ARISING IN ANY WAY OUT OF THE USE OF THIS SOFTWARE, EVEN IF ADVISED OF THE POSSIBILITY OF SUCH DAMAGE.

[1f]

Copyright (c) 1987, 1988, 2000 Regents of the University of California.
All rights reserved.

Redistribution and use in source and binary forms are permitted provided that: (1) source distributions retain this entire copyright notice and comment, and (2) distributions including binaries display the following acknowledgement: "This product includes software developed by the University of California, Berkeley and its contributors" in the documentation or other materials provided with the distribution. Neither the name of the University nor the names of its contributors may be used to endorse or promote products derived from this software without specific prior written permission.

THIS SOFTWARE IS PROVIDED "AS IS" AND WITHOUT ANY EXPRESS OR IMPLIED WARRANTIES, INCLUDING, WITHOUT LIMITATION, THE IMPLIED WARRANTIES OF MERCHANTABILITY AND FITNESS FOR A PARTICULAR PURPOSE.

(3) David M. Gay at AT&T

The author of this software is David M. Gay.

Copyright (c) 1991 by AT&T.

Permission to use, copy, modify, and distribute this software for any purpose without fee is hereby granted, provided that this entire notice is included in all copies of any software which is or includes a copy or modification of this software and in all copies of the supporting documentation for such software.

THIS SOFTWARE IS BEING PROVIDED "AS IS", WITHOUT ANY EXPRESS OR IMPLIED WARRANTY. IN PARTICULAR, NEITHER THE AUTHOR NOR AT&T MAKES ANY REPRESENTATION OR WARRANTY OF ANY KIND CONCERNING THE MERCHANTABILITY OF THIS SOFTWARE OR ITS FITNESS FOR ANY PARTICULAR PURPOSE.

(11) Christopher G. Demetriou

Copyright (c) 2001 Christopher G. Demetriou
All rights reserved.

Redistribution and use in source and binary forms, with or without modification, are permitted provided that the following conditions are met:

1. Redistributions of source code must retain the above copyright notice, this list of conditions and the following disclaimer.
2. Redistributions in binary form must reproduce the above copyright

notice, this list of conditions and the following disclaimer in the documentation and/or other materials provided with the distribution.

3. The name of the author may not be used to endorse or promote products derived from this software without specific prior written permission.

THIS SOFTWARE IS PROVIDED BY THE AUTHOR "AS IS" AND ANY EXPRESS OR IMPLIED WARRANTIES, INCLUDING, BUT NOT LIMITED TO, THE IMPLIED WARRANTIES OF MERCHANTABILITY AND FITNESS FOR A PARTICULAR PURPOSE ARE DISCLAIMED. IN NO EVENT SHALL THE AUTHOR BE LIABLE FOR ANY DIRECT, INDIRECT, INCIDENTAL, SPECIAL, EXEMPLARY, OR CONSEQUENTIAL DAMAGES (INCLUDING, BUT NOT LIMITED TO, PROCUREMENT OF SUBSTITUTE GOODS OR SERVICES; LOSS OF USE, DATA, OR PROFITS; OR BUSINESS INTERRUPTION) HOWEVER CAUSED AND ON ANY THEORY OF LIABILITY, WHETHER IN CONTRACT, STRICT LIABILITY, OR TORT (INCLUDING NEGLIGENCE OR OTHERWISE) ARISING IN ANY WAY OUT OF THE USE OF THIS SOFTWARE, EVEN IF ADVISED OF THE POSSIBILITY OF SUCH DAMAGE.

(13) Royal Institute of Technology

Copyright (c) 1999 Kungliga Tekniska Högskolan
(Royal Institute of Technology, Stockholm, Sweden).
All rights reserved.

Redistribution and use in source and binary forms, with or without modification, are permitted provided that the following conditions are met:

1. Redistributions of source code must retain the above copyright notice, this list of conditions and the following disclaimer.
2. Redistributions in binary form must reproduce the above copyright notice, this list of conditions and the following disclaimer in the documentation and/or other materials provided with the distribution.
3. Neither the name of KTH nor the names of its contributors may be used to endorse or promote products derived from this software without specific prior written permission.

THIS SOFTWARE IS PROVIDED BY KTH AND ITS CONTRIBUTORS "AS IS" AND ANY EXPRESS OR IMPLIED WARRANTIES, INCLUDING, BUT NOT LIMITED TO, THE IMPLIED WARRANTIES OF MERCHANTABILITY AND FITNESS FOR A PARTICULAR PURPOSE ARE DISCLAIMED. IN NO EVENT SHALL KTH OR ITS CONTRIBUTORS BE LIABLE FOR ANY DIRECT, INDIRECT, INCIDENTAL, SPECIAL, EXEMPLARY, OR CONSEQUENTIAL DAMAGES (INCLUDING, BUT NOT LIMITED TO, PROCUREMENT OF SUBSTITUTE GOODS OR SERVICES; LOSS OF USE, DATA, OR PROFITS; OR BUSINESS INTERRUPTION) HOWEVER CAUSED AND ON ANY THEORY OF LIABILITY, WHETHER IN CONTRACT, STRICT LIABILITY, OR TORT (INCLUDING NEGLIGENCE OR OTHERWISE) ARISING IN ANY WAY OUT OF THE USE OF THIS SOFTWARE, EVEN IF ADVISED OF THE POSSIBILITY OF SUCH DAMAGE.

(14) Alexey Zelkin

Copyright (c) 2000, 2001 Alexey Zelkin <phantom@FreeBSD.org>
All rights reserved.

Redistribution and use in source and binary forms, with or without modification, are permitted provided that the following conditions are met:

1. Redistributions of source code must retain the above copyright notice, this list of conditions and the following disclaimer.

2. Redistributions in binary form must reproduce the above copyright notice, this list of conditions and the following disclaimer in the documentation and/or other materials provided with the distribution.

THIS SOFTWARE IS PROVIDED BY THE AUTHOR AND CONTRIBUTORS "AS IS" AND ANY EXPRESS OR IMPLIED WARRANTIES, INCLUDING, BUT NOT LIMITED TO, THE IMPLIED WARRANTIES OF MERCHANTABILITY AND FITNESS FOR A PARTICULAR PURPOSE ARE DISCLAIMED. IN NO EVENT SHALL THE AUTHOR OR CONTRIBUTORS BE LIABLE FOR ANY DIRECT, INDIRECT, INCIDENTAL, SPECIAL, EXEMPLARY, OR CONSEQUENTIAL DAMAGES (INCLUDING, BUT NOT LIMITED TO, PROCUREMENT OF SUBSTITUTE GOODS OR SERVICES; LOSS OF USE, DATA, OR PROFITS; OR BUSINESS INTERRUPTION) HOWEVER CAUSED AND ON ANY THEORY OF LIABILITY, WHETHER IN CONTRACT, STRICT LIABILITY, OR TORT (INCLUDING NEGLIGENCE OR OTHERWISE) ARISING IN ANY WAY OUT OF THE USE OF THIS SOFTWARE, EVEN IF ADVISED OF THE POSSIBILITY OF SUCH DAMAGE.

(15) Andrey A. Chernov

Copyright (C) 1997 by Andrey A. Chernov, Moscow, Russia.
All rights reserved.

Redistribution and use in source and binary forms, with or without modification, are permitted provided that the following conditions are met:

1. Redistributions of source code must retain the above copyright notice, this list of conditions and the following disclaimer.
2. Redistributions in binary form must reproduce the above copyright notice, this list of conditions and the following disclaimer in the documentation and/or other materials provided with the distribution.

THIS SOFTWARE IS PROVIDED BY THE AUTHOR "AS IS" AND ANY EXPRESS OR IMPLIED WARRANTIES, INCLUDING, BUT NOT LIMITED TO, THE IMPLIED WARRANTIES OF MERCHANTABILITY AND FITNESS FOR A PARTICULAR PURPOSE ARE DISCLAIMED. IN NO EVENT SHALL THE REGENTS OR CONTRIBUTORS BE LIABLE FOR ANY DIRECT, INDIRECT, INCIDENTAL, SPECIAL, EXEMPLARY, OR CONSEQUENTIAL DAMAGES (INCLUDING, BUT NOT LIMITED TO, PROCUREMENT OF SUBSTITUTE GOODS OR SERVICES; LOSS OF USE, DATA, OR PROFITS; OR BUSINESS INTERRUPTION) HOWEVER CAUSED AND ON ANY THEORY OF LIABILITY, WHETHER IN CONTRACT, STRICT LIABILITY, OR TORT (INCLUDING NEGLIGENCE OR OTHERWISE) ARISING IN ANY WAY OUT OF THE USE OF THIS SOFTWARE, EVEN IF ADVISED OF THE POSSIBILITY OF SUCH DAMAGE.

(16) FreeBSD

Copyright (c) 1997-2002 FreeBSD Project.
All rights reserved.

Redistribution and use in source and binary forms, with or without modification, are permitted provided that the following conditions are met:

1. Redistributions of source code must retain the above copyright notice, this list of conditions and the following disclaimer.
2. Redistributions in binary form must reproduce the above copyright notice, this list of conditions and the following disclaimer in the documentation and/or other materials provided with the distribution.

THIS SOFTWARE IS PROVIDED BY THE AUTHOR AND CONTRIBUTORS "AS IS" AND ANY EXPRESS OR IMPLIED WARRANTIES, INCLUDING, BUT NOT LIMITED TO, THE IMPLIED WARRANTIES OF MERCHANTABILITY AND FITNESS FOR A PARTICULAR PURPOSE

ARE DISCLAIMED. IN NO EVENT SHALL THE AUTHOR OR CONTRIBUTORS BE LIABLE FOR ANY DIRECT, INDIRECT, INCIDENTAL, SPECIAL, EXEMPLARY, OR CONSEQUENTIAL DAMAGES (INCLUDING, BUT NOT LIMITED TO, PROCUREMENT OF SUBSTITUTE GOODS OR SERVICES; LOSS OF USE, DATA, OR PROFITS; OR BUSINESS INTERRUPTION) HOWEVER CAUSED AND ON ANY THEORY OF LIABILITY, WHETHER IN CONTRACT, STRICT LIABILITY, OR TORT (INCLUDING NEGLIGENCE OR OTHERWISE) ARISING IN ANY WAY OUT OF THE USE OF THIS SOFTWARE, EVEN IF ADVISED OF THE POSSIBILITY OF SUCH DAMAGE.

(17) S. L. Moshier

Author: S. L. Moshier.

Copyright (c) 1984,2000 S.L. Moshier

Permission to use, copy, modify, and distribute this software for any purpose without fee is hereby granted, provided that this entire notice is included in all copies of any software which is or includes a copy or modification of this software and in all copies of the supporting documentation for such software.

THIS SOFTWARE IS BEING PROVIDED "AS IS", WITHOUT ANY EXPRESS OR IMPLIED WARRANTY. IN PARTICULAR, THE AUTHOR MAKES NO REPRESENTATION OR WARRANTY OF ANY KIND CONCERNING THE MERCHANTABILITY OF THIS SOFTWARE OR ITS FITNESS FOR ANY PARTICULAR PURPOSE.

(18) Citrus Project

Copyright (c)1999 Citrus Project,
All rights reserved.

Redistribution and use in source and binary forms, with or without modification, are permitted provided that the following conditions are met:

1. Redistributions of source code must retain the above copyright notice, this list of conditions and the following disclaimer.
2. Redistributions in binary form must reproduce the above copyright notice, this list of conditions and the following disclaimer in the documentation and/or other materials provided with the distribution.

THIS SOFTWARE IS PROVIDED BY THE AUTHOR AND CONTRIBUTORS "AS IS" AND ANY EXPRESS OR IMPLIED WARRANTIES, INCLUDING, BUT NOT LIMITED TO, THE IMPLIED WARRANTIES OF MERCHANTABILITY AND FITNESS FOR A PARTICULAR PURPOSE ARE DISCLAIMED. IN NO EVENT SHALL THE AUTHOR OR CONTRIBUTORS BE LIABLE FOR ANY DIRECT, INDIRECT, INCIDENTAL, SPECIAL, EXEMPLARY, OR CONSEQUENTIAL DAMAGES (INCLUDING, BUT NOT LIMITED TO, PROCUREMENT OF SUBSTITUTE GOODS OR SERVICES; LOSS OF USE, DATA, OR PROFITS; OR BUSINESS INTERRUPTION) HOWEVER CAUSED AND ON ANY THEORY OF LIABILITY, WHETHER IN CONTRACT, STRICT LIABILITY, OR TORT (INCLUDING NEGLIGENCE OR OTHERWISE) ARISING IN ANY WAY OUT OF THE USE OF THIS SOFTWARE, EVEN IF ADVISED OF THE POSSIBILITY OF SUCH DAMAGE.

(19) Todd C. Miller

Copyright (c) 1998 Todd C. Miller <Todd.Miller@courtesan.com>
All rights reserved.

Redistribution and use in source and binary forms, with or without modification, are permitted provided that the following conditions

are met:

1. Redistributions of source code must retain the above copyright notice, this list of conditions and the following disclaimer.
2. Redistributions in binary form must reproduce the above copyright notice, this list of conditions and the following disclaimer in the documentation and/or other materials provided with the distribution.
3. The name of the author may not be used to endorse or promote products derived from this software without specific prior written permission.

THIS SOFTWARE IS PROVIDED ``AS IS'' AND ANY EXPRESS OR IMPLIED WARRANTIES, INCLUDING, BUT NOT LIMITED TO, THE IMPLIED WARRANTIES OF MERCHANTABILITY AND FITNESS FOR A PARTICULAR PURPOSE ARE DISCLAIMED. IN NO EVENT SHALL THE AUTHOR BE LIABLE FOR ANY DIRECT, INDIRECT, INCIDENTAL, SPECIAL, EXEMPLARY, OR CONSEQUENTIAL DAMAGES (INCLUDING, BUT NOT LIMITED TO, PROCUREMENT OF SUBSTITUTE GOODS OR SERVICES; LOSS OF USE, DATA, OR PROFITS; OR BUSINESS INTERRUPTION) HOWEVER CAUSED AND ON ANY THEORY OF LIABILITY, WHETHER IN CONTRACT, STRICT LIABILITY, OR TORT (INCLUDING NEGLIGENCE OR OTHERWISE) ARISING IN ANY WAY OUT OF THE USE OF THIS SOFTWARE, EVEN IF ADVISED OF THE POSSIBILITY OF SUCH DAMAGE.

(26) Mike Barcroft

Copyright (c) 2001 Mike Barcroft <mike@FreeBSD.org>
All rights reserved.

Redistribution and use in source and binary forms, with or without modification, are permitted provided that the following conditions are met:

1. Redistributions of source code must retain the above copyright notice, this list of conditions and the following disclaimer.
2. Redistributions in binary form must reproduce the above copyright notice, this list of conditions and the following disclaimer in the documentation and/or other materials provided with the distribution.

THIS SOFTWARE IS PROVIDED BY THE AUTHOR AND CONTRIBUTORS ``AS IS'' AND ANY EXPRESS OR IMPLIED WARRANTIES, INCLUDING, BUT NOT LIMITED TO, THE IMPLIED WARRANTIES OF MERCHANTABILITY AND FITNESS FOR A PARTICULAR PURPOSE ARE DISCLAIMED. IN NO EVENT SHALL THE AUTHOR OR CONTRIBUTORS BE LIABLE FOR ANY DIRECT, INDIRECT, INCIDENTAL, SPECIAL, EXEMPLARY, OR CONSEQUENTIAL DAMAGES (INCLUDING, BUT NOT LIMITED TO, PROCUREMENT OF SUBSTITUTE GOODS OR SERVICES; LOSS OF USE, DATA, OR PROFITS; OR BUSINESS INTERRUPTION) HOWEVER CAUSED AND ON ANY THEORY OF LIABILITY, WHETHER IN CONTRACT, STRICT LIABILITY, OR TORT (INCLUDING NEGLIGENCE OR OTHERWISE) ARISING IN ANY WAY OUT OF THE USE OF THIS SOFTWARE, EVEN IF ADVISED OF THE POSSIBILITY OF SUCH DAMAGE.

(28) Red Hat Incorporated

Unless otherwise stated in each remaining newlib file, the remaining files in the newlib subdirectory default to the following copyright. It should be noted that Red Hat Incorporated now owns copyrights belonging to Cygnus Solutions and Cygnus Support.

Copyright (c) 1994, 1997, 2001, 2002, 2003, 2004 Red Hat Incorporated.
All rights reserved.

Redistribution and use in source and binary forms, with or without modification, are permitted provided that the following conditions are met:

Redistributions of source code must retain the above copyright notice, this list of conditions and the following disclaimer.

Redistributions in binary form must reproduce the above copyright notice, this list of conditions and the following disclaimer in the documentation and/or other materials provided with the distribution.

The name of Red Hat Incorporated may not be used to endorse or promote products derived from this software without specific prior written permission.

THIS SOFTWARE IS PROVIDED BY THE COPYRIGHT HOLDERS AND CONTRIBUTORS "AS IS" AND ANY EXPRESS OR IMPLIED WARRANTIES, INCLUDING, BUT NOT LIMITED TO, THE IMPLIED WARRANTIES OF MERCHANTABILITY AND FITNESS FOR A PARTICULAR PURPOSE ARE DISCLAIMED. IN NO EVENT SHALL RED HAT INCORPORATED BE LIABLE FOR ANY DIRECT, INDIRECT, INCIDENTAL, SPECIAL, EXEMPLARY, OR CONSEQUENTIAL DAMAGES (INCLUDING, BUT NOT LIMITED TO, PROCUREMENT OF SUBSTITUTE GOODS OR SERVICES; LOSS OF USE, DATA, OR PROFITS; OR BUSINESS INTERRUPTION) HOWEVER CAUSED AND ON ANY THEORY OF LIABILITY, WHETHER IN CONTRACT, STRICT LIABILITY, OR TORT (INCLUDING NEGLIGENCE OR OTHERWISE) ARISING IN ANY WAY OUT OF THE USE OF THIS SOFTWARE, EVEN IF ADVISED OF THE POSSIBILITY OF SUCH DAMAGE.

/*

* Copyright (c) 2001, 2002 Swedish Institute of Computer Science.

* All rights reserved.

*

* Redistribution and use in source and binary forms, with or without modification,

* are permitted provided that the following conditions are met:

*

* 1. Redistributions of source code must retain the above copyright notice,

* this list of conditions and the following disclaimer.

* 2. Redistributions in binary form must reproduce the above copyright notice,

* this list of conditions and the following disclaimer in the documentation

* and/or other materials provided with the distribution.

* 3. The name of the author may not be used to endorse or promote products

* derived from this software without specific prior written permission.

*

* THIS SOFTWARE IS PROVIDED BY THE AUTHOR "AS IS" AND ANY EXPRESS OR IMPLIED

* WARRANTIES, INCLUDING, BUT NOT LIMITED TO, THE IMPLIED WARRANTIES OF

* MERCHANTABILITY AND FITNESS FOR A PARTICULAR PURPOSE ARE DISCLAIMED. IN NO EVENT

* SHALL THE AUTHOR BE LIABLE FOR ANY DIRECT, INDIRECT, INCIDENTAL, SPECIAL,

* EXEMPLARY, OR CONSEQUENTIAL DAMAGES (INCLUDING, BUT NOT LIMITED TO, PROCUREMENT

* OF SUBSTITUTE GOODS OR SERVICES; LOSS OF USE, DATA, OR PROFITS; OR BUSINESS

* INTERRUPTION) HOWEVER CAUSED AND ON ANY THEORY OF LIABILITY, WHETHER IN

* CONTRACT, STRICT LIABILITY, OR TORT (INCLUDING NEGLIGENCE OR OTHERWISE) ARISING

* IN ANY WAY OUT OF THE USE OF THIS SOFTWARE, EVEN IF ADVISED OF THE POSSIBILITY

* OF SUCH DAMAGE.

*

* This file is part of the lwIP TCP/IP stack.

*

* Author: Adam Dunkels <adam@sics.se>

*

*/