

Panasonic®

Operating Instructions Wireless Speaker System

Model No. **SC-ALL05**

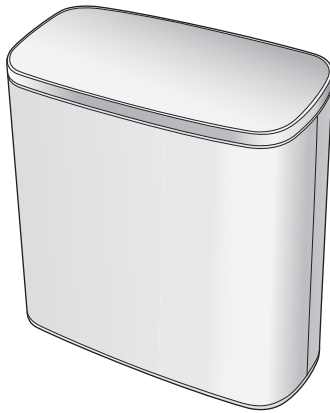

Thank you for purchasing this product.

Please read these instructions carefully before using this product, and save this manual for future use.

Model number suffix "EB" denotes UK model.

EG **EB** **GN**

SQT1372-2

Safety precautions

WARNING

Unit

- To reduce the risk of fire, electric shock or product damage,
 - Do not let water or other liquids drip or splash inside the unit.
 - Do not expose accessories (AC mains lead, AC adaptor and etc.) to rain, moisture, dripping or splashing.
 - Do not place objects filled with liquids, such as vases, on accessories.
 - Use only the recommended accessories.
 - Do not remove covers.
 - Do not repair this unit by yourself. Refer servicing to qualified service personnel.
 - Do not let metal objects fall inside this unit.
 - Do not place any item on top of this unit.

AC mains lead

- To reduce the risk of fire, electric shock or product damage,
 - Ensure that the power supply voltage corresponds to the voltage printed on this unit.
 - Insert the mains plug fully into the socket outlet.
 - Do not pull, bend, or place heavy items on the lead.
 - Do not handle the plug with wet hands.
 - Hold onto the mains plug body when disconnecting the plug.
 - Do not use a damaged mains plug or socket outlet.
- The mains plug is the disconnecting device.
Install this unit so that the mains plug can be unplugged from the socket outlet immediately.

CAUTION

Unit

- Do not place sources of naked flames, such as lighted candles, on this unit.
- Do not leave the unit in a car exposed to direct sunlight for a long period of time with doors and windows closed.
- This unit may receive radio interference caused by mobile telephones during use. If such interference occurs, please increase separation between this unit and the mobile telephone.

Placement

- Place this unit on an even surface.
- To reduce the risk of fire, electric shock or product damage,
 - Do not install or place this unit in a bookcase, built-in cabinet or in another confined space. Ensure this unit is well ventilated.
 - Do not obstruct this unit's ventilation openings with newspapers, tablecloths, curtains, and similar items.
 - Do not expose this unit to direct sunlight, high temperatures, high humidity, and excessive vibration.

AC mains lead

- Do not use AC mains lead with other equipment.

Batteries

- This unit has a built-in battery.
 - In order to secure splashproof performance, battery replacement by the customer is not guaranteed. If you desire battery replacement, please contact our service department.
- The following is the caution for removing the battery when disposing of this unit (→ 23).
 - Do not heat or expose to flame.
 - Do not short circuit.
 - Do not disassemble, crush.
 - Do not re-use.
 - Do not place in microwave ovens.
 - Do not leave the battery(ies) in a car exposed to direct sunlight for a long period of time with doors and windows closed.

Caution for AC Mains Lead



(For the AC mains plug of three pins)

For your safety, please read the following text carefully.

This appliance is supplied with a moulded three pin mains plug for your safety and convenience.

A 3-ampere fuse is fitted in this plug.

Should the fuse need to be replaced please ensure that the replacement fuse has a rating of 3-ampere and that it is approved by ASTA or BSI to BS1362.

Check for the ASTA mark  or the BSI mark  on the body of the fuse.

If the plug contains a removable fuse cover you must ensure that it is refitted when the fuse is replaced.

If you lose the fuse cover the plug must not be used until a replacement cover is obtained.

A replacement fuse cover can be purchased from your local dealer.

Before use

Remove the connector cover.

How to replace the fuse

The location of the fuse differ according to the type of AC mains plug (figures A and B). Confirm the AC mains plug fitted and follow the instructions below.

Illustrations may differ from actual AC mains plug.

1. Open the fuse cover with a screwdriver.

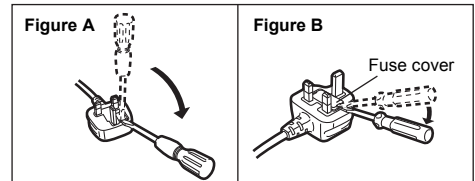

2. Replace the fuse and close or attach the fuse cover.

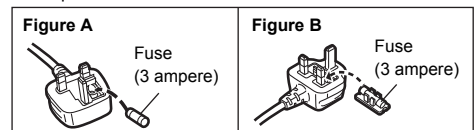

Table of contents

Safety precautions	2
Unit care	3
Accessories	3
About Waterproof Performance	4
Control reference guide	6
Charging	8
Network settings	9
Streaming music over the network.....	13
Bluetooth® operations	16
Firmware updates	18
Others	19
Troubleshooting	21
Disposing of this unit.....	23
About Bluetooth®.....	24
Specifications.....	24
Licenses.....	26
Limited Warranty (ONLY FOR AUSTRALIA)	39

About descriptions in these operating instructions

- Pages to be referred to are indicated as "→ ○○".
- Labels on this unit are indicated as [○○] in these operating instructions.
- The illustrations shown may differ from your unit.
- These operating instructions are applicable to model SC-ALL05 for variety of regions. Unless otherwise indicated, illustrations in these operating instructions are of the model for the United Kingdom and Ireland.

Unit care

Turn off this unit first, and then wipe it with a soft, dry cloth. After each use of the AC adaptor, disconnect the AC mains plug from the electrical outlet, and wipe the AC adaptor.

- To clean heavily stained surfaces, wring a cloth moistened in water tightly to wipe off the stains first, and then wipe the surfaces gently with a soft, dry cloth.
- Do not use solvents such as benzine, paint thinner, alcohol, or dishwashing soap or a chemically treated cloth, as these may damage the outer casing and cause the surface finish to peel off.

Accessories

Check the supplied accessories before using this system.

1 AC mains lead

SC-ALL05EB-K
(TZH3CC003)

SC-ALL05EB-W
(TZH3CC004)



SC-ALL05EG-K
(TZH3CC001)

SC-ALL05EG-W
(TZH3CC002)



SC-ALL05GN-K
(TZH3CC005)



1 AC adaptor

SC-ALL05EB-K **SC-ALL05EG-K** **SC-ALL05GN-K**
(SAE0011AD)

SC-ALL05EB-W **SC-ALL05EG-W**
(SAE0011EA)

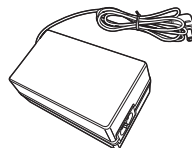

- Product numbers are correct as of March 2016. These may be subject to change.
- The supplied AC mains lead is for use with this system only. Do not use it with other equipment. Also, do not use cords from other equipment with this system.

About Waterproof Performance

This unit is waterproof in accordance with IPX5/IPX7 in JIS C 0920 (IEC 60529) “Degrees of protection provided by enclosures (IP code)”. For correct and safe use of the device, read the instructions below carefully in advance.

- The supplied AC adaptor and the terminals are not waterproof.

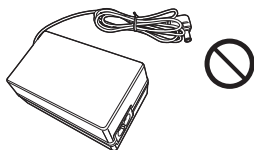

About IPX5/IPX7

IPX5 (degree of protection against water jets)

This unit retains its functionality after being subjected to room temperature tap water projected at all angles through a nozzle with an inner diameter of 6.3 mm at a flow rate of approximately 12.5 L/minute for at least 3 minutes from a distance of approximately 3 m.

IPX7 (degree of protection against immersion)

This unit retains its functionality after being slowly immersed and left for 30 minutes in 1 m of room temperature tap water and then removed.

Liquids that fall under the waterproof design of this unit

Applicable	Fresh water, tap water
Not applicable*	Soap water, shampoo, detergent, hot spring water, pool water, seawater, hot water

* Do not expose to liquids that are not applicable.

Notes on the use of this unit in wet areas (bathroom, kitchen, etc.)

Observe the following points, as incorrect use may cause malfunctions:

- **Close the terminal cover completely. Be sure to lock it.**
- **Do not use this unit while the AC adaptor or a LAN cable is connected.**
- **Do not place this unit on induction cooktops.**
- **Do not immerse this unit in water, bathtubs or similar locations on purpose, or operate it underwater.** If you should accidentally drop this unit in a bathtub, pick it up as soon as possible and wipe it with a soft cloth. Bubbles will leak out of this unit if it is dropped in water, but this is not a malfunction.
- **Place this unit on an even surface.**
- **Do not leave this unit in humid locations, such as bathrooms.**
- **Do not use this unit in sauna rooms or mist sauna rooms.**
- **Do not use this unit when it has been suddenly taken from a cold outdoor environment to a bathroom.** When this unit is cold, condensation may occur if you take it to a humid location such as a bathroom. Water droplets may form inside this unit during use.
- **If water droplets splash on the top panel (→ 6), the buttons may respond, or may not respond to your commands. When this occurs, wipe them off lightly before operating this unit.**

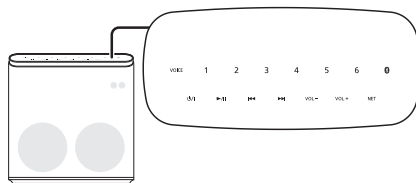

You can lock the buttons when using the rechargeable battery. (This will prevent their accidental operation caused by water droplets, etc.) (→ 7)

To maintain the waterproof performance

Do not drop this unit, subject it to an impact, or apply excessive pressure to it.

Doing so may deform or damage this unit, making it impossible to maintain the waterproof performance.

To maintain the waterproof performance, we recommend that you replace the waterproofing components of this unit, such as the rubber gaskets, at least once every two years (for a fee). For more information, contact your dealer or nearest service centre.

Handling of the terminal cover

If you use this unit while the cover is open, water may leak in and malfunctions may result.

Follow the steps below to lock the cover before use:

- ① Push both ends of the cover in with your fingers to close it completely.
- ② Set the switch to [LOCK].

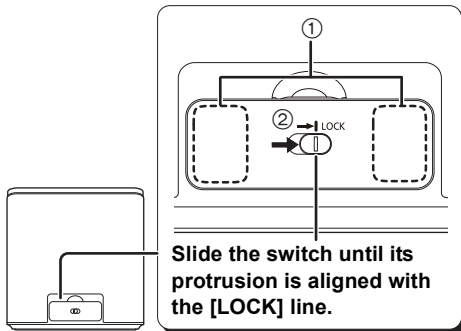

Keep the following points in mind when closing the cover:

- Do not open or close the cover when your hands are wet or when water droplets are found on this unit.
- After closing the cover, ensure that there are no gaps.

Example of gaps

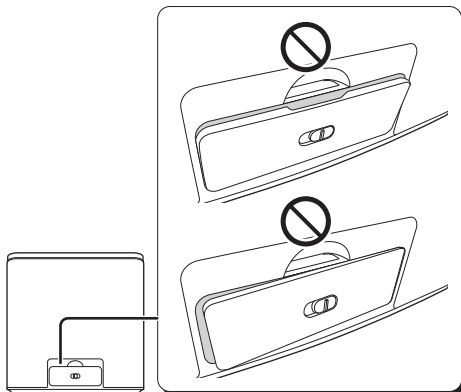

If water should accumulate in the terminal compartment behind the terminal cover, stop using this unit immediately and consult your dealer. Malfunctions resulting from incorrect handling by customers are not covered by the warranty.

After use in wet areas

Wipe this unit with a soft, dry cloth, and leave it indoors.

- **The AC adaptor (→ 3) is not waterproof.**
If there is water on the surface around the terminal cover, wipe it off with a cloth, etc. before connecting the DC plug. (→ 8)
- If the DC IN terminal is dirty, clean it with a cotton swab or similar material before connecting the DC plug.
- Wipe off water droplets completely from the speaker cover. (Poor sound quality may result if the cover is clogged).
- If liquids such as soap water or shampoo are splashed on this unit, rinse it under a low flow of room temperature tap water first, and then wipe it. (Do not use detergents to clean it.)
- Do not dry this unit with hot air from an electric appliance (hair dryer, etc.).
- In cold climates, leaving this unit with water droplets may cause the cover to be stuck closed due to freezing. Other adverse effects may also occur.
- Water may accumulate in this unit.
Tilt this unit left and right to drain the water from the water drain holes on the bottom of this unit.

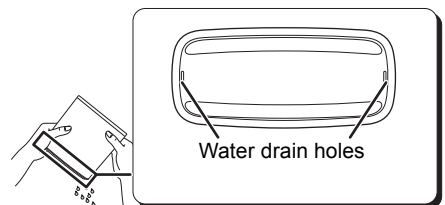

Control reference guide

Front

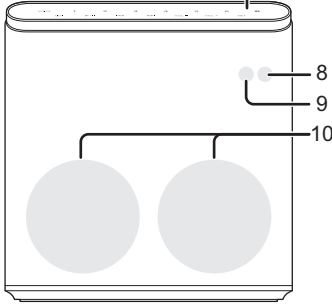

○ : Touch area
 These switches work just by touching the marks. Each time you touch the switch, there will be a beep sound. The beep sound can be set to off. (→ 19)

Rear

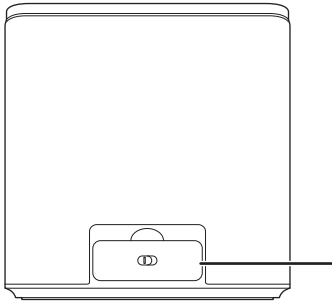

How to open the terminal cover

When the cover is open

- 1 **VOICE button/indicator [VOICE]**
 Enhances voice clarity in noisy environments such as a bathroom or kitchen.
 Touch to switch the setting.

[VOICE] status	Setting
Lights	Enabled
Off	Disabled

- 2 **Internet radio preset channel buttons/indicators [1] to [6]**
 Saves Internet radio channels. (→ 14)
- 3 **Bluetooth® button/indicator [Bluetooth icon]**
 Selects Bluetooth® mode.
- 4 **Standby/on button/indicator [Power icon]**
 Touch to switch the unit from on to standby mode or vice versa. In standby mode, the unit is still consuming a small amount of power.

- 5 **Playback operation buttons/indicators**
 Operate these switches to play music via Bluetooth® or over a network.

To start playback:
 Touch [▶/||]

To pause:
 Touch [▶/||] during playback.
 ● Touch again to resume from where you paused.

To skip tracks:
 Touch [◀◀] or [▶▶].
 ● If you touch either of them while playing an Internet radio station, it will stop playing.
 Touch [▶/||] to start playing the station.



- Depending on your device or its conditions, you may not be able to operate this unit.

6 Volume control button/indicator [VOL –]/ [VOL +]

Adjust the volume.

7 Network button/indicator [NET]

Selects Network mode.

- Blinks slowly while the firmware of this unit is being updated. (→ 18)

8 Operation indicator (amber)

<p>Blinks once</p> <ul style="list-style-type: none"> • The unit detects the switch touched. • The following setting is turned on. <ul style="list-style-type: none"> – “Network standby” (→ 12) – “Bluetooth® standby” (→ 17) – “Automatic updates” (→ 18) – “Operation sound setting” (→ 19) • Bluetooth® input level is set to Low. (→ 17) • The brightness of switches and lamps is set to “Bright”. (→ 19) • The standby mode setting has been changed so that the standby function remains enabled until the battery becomes empty. (→ 19)
<p>Blinks twice</p> <ul style="list-style-type: none"> • The unit detects a valid operation performed by touching and holding the switch. • One of the following functions is turned off. <ul style="list-style-type: none"> – “Network standby” (→ 12) – “Bluetooth® standby” (→ 17) – “Automatic updates” (→ 18) – “Operation sound setting” (→ 19) • Bluetooth® input level is set to Middle. (→ 17) • The brightness of switches and lamps is set to “Moderately dim”. (→ 19) • The standby mode setting has been changed so that the standby function is disabled regardless of its setting. (→ 19)
<p>Blinks thrice</p> <ul style="list-style-type: none"> • Bluetooth® input level is set to High. (→ 17) • The brightness of switches and lamps is set to “Dim”. (→ 19)
<p>Blinks fast (when the rechargeable battery is in use)</p> <ul style="list-style-type: none"> • The battery is almost empty.
<p>Blinks fast (when the AC adaptor is in use)</p> <ul style="list-style-type: none"> • An error has occurred during charging.
<p>Lights up</p> <ul style="list-style-type: none"> • The battery is being charged.

9 Network indicator (blue/red/purple)

<p>Blinks alternately (blue/red)</p> <ul style="list-style-type: none"> • The unit is carrying out an internal process. <ul style="list-style-type: none"> – Wait for approximately 60 seconds before the blinking stops.
<p>Lights up (blue)</p> <ul style="list-style-type: none"> • The unit is connected to the network.
<p>Blinks slowly (blue)</p> <ul style="list-style-type: none"> • The unit is ready for network setup. (→ 9)
<p>Blinks (blue)</p> <ul style="list-style-type: none"> • The unit is waiting for the WPS connection. (→ 11)
<p>Blinks fast (blue)</p> <ul style="list-style-type: none"> • The unit is waiting for the WPS PIN code connection. (→ 11)
<p>Blinks (red)</p> <ul style="list-style-type: none"> • The unit is connecting to the network. <ul style="list-style-type: none"> – When the network connection cannot be established, the blinking keeps going. Check the network connection. (→ 9)
<p>Blinks thrice (purple)</p> <ul style="list-style-type: none"> • The network standby function and Bluetooth® standby function are enabled. (→ 19)



- The volume cannot be changed during the network indicator blinking blue.

10 Speakers

11 RESET button [RESET]

Press this button with a paper clip or similar object when this unit is not working correctly, for example.

12 LAN terminal

13 DC IN terminal

⎓ DC 12 V 3 A

To lock the buttons (only when using the rechargeable battery)

- ① Touch and hold [VOL –] and [VOL +] on this unit for at least 4 seconds.
- ② The buttons will be locked and the lamps of [VOL –] and [VOL +] will blink. (Lamps other than [⏻/⏻] will go off.)

To unlock the buttons (only when using the rechargeable battery)

- ① Touch and hold [VOL –] and [VOL +] on this unit for at least 4 seconds.
- ② The buttons will be unlocked and their lamps will light up. (The buttons will also be unlocked if you connect the AC adaptor while they are locked.)

Charging

The rechargeable battery is not charged at the time of purchase. Charge it before use.

- This unit houses a lithium-ion rechargeable battery. Do not remove it except for when disposing of the product.

e.g.,

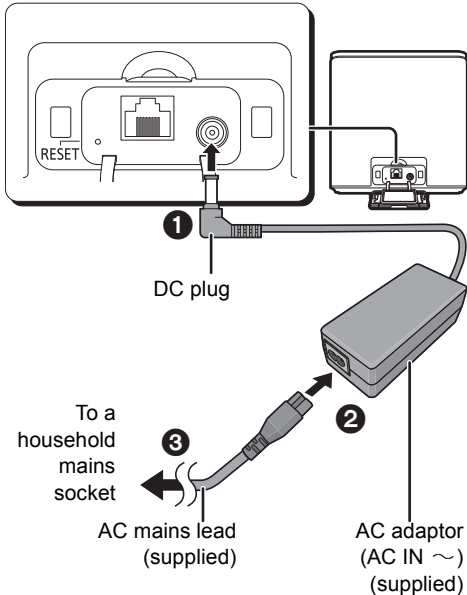

The operation indicator lights up during charging, and goes off when charging is completed.



- **The AC adaptor is not waterproof.**
When the DC plug of the AC adaptor is wet or dirty, clean it with a cotton swab, cloth or similar material before connecting the AC adaptor.
- This unit consumes a small amount of AC power (→ 24) even when turned off.
- When this unit is not used over a long period of time, charge the built-in battery at least once every six months to prevent it from deteriorating.
- Charging may not start if the battery level is sufficiently high even if it is not full.
- It is recommended to charge the battery in the temperature of between 10 °C and 35 °C. The Operation indicator (amber) may flash and charging may not be possible when it is out of recommended temperature range.
- The battery may not charge when the temperature surrounding the battery is high during the operation or right after the operation even when it is within the recommended temperature range. In such case, stop the usage and let it cool down.

- To ensure safety, in the case of an excessive input signal, the system may be automatically interrupted and power is turned off.
- This speaker does not have magnetic shielding. Do not place watches or magnetic cards (credit cards) near this unit, or place this unit near a CRT television or similar device.
- The unit is in the standby condition when the AC adaptor is connected. The primary circuit is always "live" as long as the AC adaptor is connected to an electrical outlet.
- Do not use any other AC adaptors except the supplied one.

Auto off function

This unit is designed to conserve its power consumption and save energy. If this unit receives no input signal and its switches and other controls are not operated for at least 20 minutes, it will turn off automatically.

- [⏻/⏸] blinks for approximately 1 minute before the unit turns to standby mode. Touch any switch to cancel it.

Charging times and the operating time of the battery

Charging time ^{※1} (When this unit is off)	Operating time of the battery ^{※2}	
	When Bluetooth® mode is selected ^{※3, ※4}	When Network mode is selected ^{※3, ※4}
3.5 hours (approx.)	9 hours (approx.)	8.5 hours (approx.)

- ※1 At an ambient temperature of 25 °C and after the battery is discharged completely
- ※2 Measured according to CP2905B, a testing method specified by the Japan Electronics and Information Technology Industries Association, or JEITA. (In this method, the battery is used at an ambient temperature of 25 °C while the unit is connected to a Wi-Fi® network or a Bluetooth® device.)
- ※3 The brightness of switches and lamps is set to "Dim". (→ 19)
- ※4 By measurement of our company standards

Indicator illumination for the battery capacity

The operation indicator blinks for low battery.



- You can also check the battery capacity using the "Panasonic Music Streaming" app. (→ 13)

Using the unit by connecting it to a household mains socket

Touch [⏻/⏸] to turn on the unit. Connecting the AC adaptor before turning on the unit allows you to supply power from a household mains socket during use.

- It takes longer to charge while this unit is turned on.

Network settings

When this unit is connected to a network, you can enjoy music stored on devices that support Qualcomm® AllPlay™ through the speaker of this unit.

To use these features, this unit must join the same network as the device.

Qualcomm® AllPlay™ smart media platform is a product of Qualcomm Connected Experiences, Inc.

Devices that support AllPlay (examples)

- iOS devices (iPhone, iPod touch, iPad)
 - Android™ devices
- Please update the unit's firmware after the network settings are complete. (→ 18)

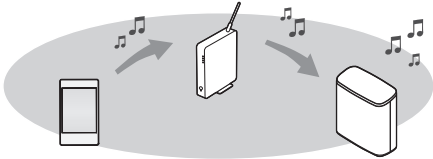

Choose a network setting method from the following.

■ Wireless LAN connection

Method 1: "Using the app "Panasonic Music Streaming"" (→ right)

- You can make the wireless network settings with the app, "Panasonic Music Streaming" (free of charge).

Method 2: "Using an Internet browser" (→ 10)

- You can access this unit's network settings from the Internet browser on your smartphone or tablet, etc.

Method 3: "Using WPS (Wi-Fi Protected Setup™)" (→ 11)

- Choose this connection method if your wireless broadband router supports WPS. Press the WPS button or enter a PIN code to establish a wireless LAN connection to this unit.

■ Wired LAN connection

Method 4: "Using a LAN cable" (→ 11)

- You can make a stable connection to the network with a LAN cable.



- The setting will be cancelled after the set time limit. In that case, try the setting again.
- To cancel this setting in the middle, touch [⏻/⏹] to turn off the unit.
- If a connection attempt fails, please also try other connection methods.

Method 1:

Using the app "Panasonic Music Streaming"

- You can also refer to the supplied "Wi-Fi® QUICK SETUP GUIDE".
- Do not connect a LAN cable. Doing so will disable the Wi-Fi function.

1 Download the app "Panasonic Music Streaming" (free of charge) on your smartphone/tablet.

(Always use the latest version of the app.)

- **iOS** : App Store
- **Android** : Google Play™



2 Start the app and follow the on-screen instructions.

3 Check that the connection has completed.

- When the connection is established, the network indicator (blue) lights up.

The operations and on-screen display items, etc. of the app "Panasonic Music Streaming" are subject to change.

For the latest information, visit

<http://panasonic.jp/support/global/cs/audio/app/>
(This site is in English only.)

Method 2:
Using an Internet browser

- The following steps are based on a smartphone.
- Do not connect a LAN cable. Doing so will disable the Wi-Fi function.

1 Turn this unit on.

- Proceed to the next step after the network indicator changes from blinking in blue and red to blinking slowly in blue.
- The blinking in blue starts after approximately 1 minute. If the blinking in blue does not start, perform a network reset. (→ 12)

2 Go to Wi-Fi settings on the device.



3 Select “AllPlay [] [] [] [] []_AJ” to connect to this unit.

- “[]” stands for a character that is unique to each set.
- This can take up to 1 minute to appear in your Wi-Fi list.
- If this operation does not work correctly, please repeat it several times.
- Make sure that DHCP is enabled for the network setting on your compatible device.

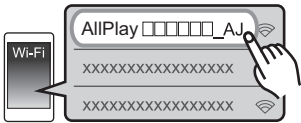

About the network setting page

[iOS device]: The settings page will be automatically displayed in the Internet browser.

[Except iOS device]: Open the Internet browser and refresh the page to display the settings page.

- If the settings page is not displayed, type “http://172.19.42.1/” into the URL address field.

4 Type a device name and then select “Next”.

- The device name will be displayed as this unit’s name on the network.
- The guaranteed limit is 32 characters.
- Emoji characters are not supported.
- The device name is set when “Next” is selected.
- You can also change the device name after the network connection is set up. (→ 12)

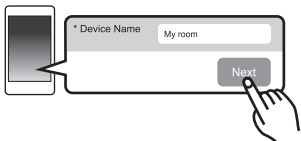

5 Select your network name (SSID) and type the password.

- Check the wireless router for the network name (SSID) and the password.
- A list of network names (SSIDs) will be appeared when you select the “Network Name” box.
- To show the characters typed in the “Password” box, select “Show Password”.
- If your network requires specific settings, deselect “DHCP” to disable DHCP.
 - You can use specific IP address, subnet mask, default gateway, primary DNS, etc.
- To update the network name (SSID) list, select “Refresh list”.

6 Select “Connect” to apply the settings.

- When the connection is established, the network indicator (blue) lights up.
- Depending on the device, the connection complete screen may not be displayed.

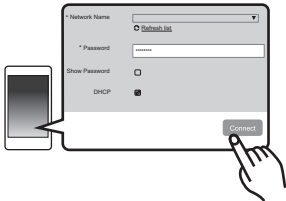

If the network indicator does not light up, check the network name (SSID) and the password, and then try the setting again.

7 Make sure to connect your compatible device back to your home wireless network.



- Enable Java and cookies in your browser settings.

Method 3:

Using WPS (Wi-Fi Protected Setup™)

- Do not connect a LAN cable. Doing so will disable the Wi-Fi function.

e.g.,

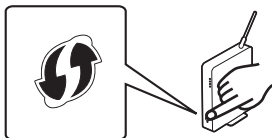

A compatible wireless router may have the WPS identifier mark.

1 Turn this unit on.

- Proceed to the next step after the network indicator changes from blinking in blue and red to blinking slowly in blue.
- The blinking in blue starts after approximately 1 minute. If the blinking in blue does not start, perform a network reset. (→ 12)

2 Touch and hold [NET] on the unit for at least 4 seconds.

- The network indicator (blue) blinks.

3 Activate the WPS button on the wireless router.

- When the connection is established, the network indicator (blue) lights up.

■ Using the WPS PIN code

After step 1

2 Touch and hold [NET], [1] and [2] for at least 4 seconds.

- The network indicator (blue) blinks faster.

3 Enter the PIN code “64428147” into the wireless router.

- When the connection is established, the network indicator (blue) lights up.



- Once the unit enters WPS PIN code mode, you cannot set up using the WPS button. To use the WPS button, turn off and then on the unit, and redo the network settings.
- Depending on a router, other connected devices may temporarily lose their connection.
- For details, refer to the operating instructions of the wireless router.

Method 4:

Using a LAN cable

1 Connect this unit to a broadband router, etc. using a LAN cable.

e.g.,

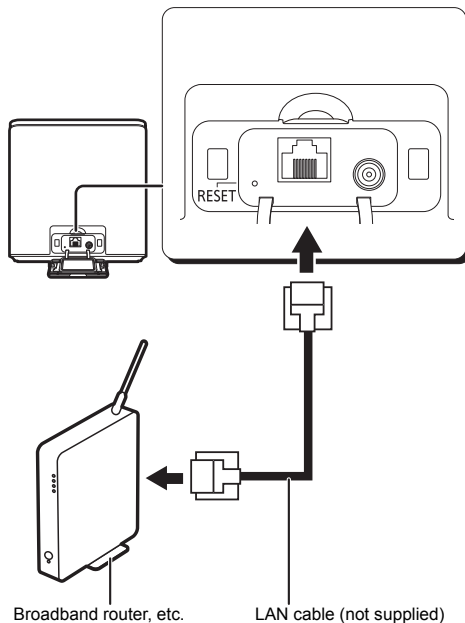

2 Turn the unit on.

- When the connection is established, the network indicator (blue) lights up.



- Use category 7 or above straight LAN cables (STP) when connecting to peripheral devices.
- Inserting any cable other than a LAN cable in the LAN port can damage the unit.
- When a LAN cable is connected, the Wi-Fi function will be disabled.

To make network-related settings

You can change this unit's name on the network, and use specific IP address, subnet mask, default gateway, primary DNS, etc.

You can also change the name of this unit by changing a setting in the app "Panasonic Music Streaming" (version 3.1.0 or later) (→ 13). For details on the app, refer to the site below.
<http://panasonic.jp/support/global/cs/audio/app/>
(This site is in English only.)

Preparation

- Complete the network settings. (→ 9)
- Connect your device (PC, etc.) to the same network as this unit.
- Check and make a note of the IP address assigned to this unit (→ 20).

1 Start an Internet browser on your device and then type this unit's IP address into the address field to display the settings page.

- It may take a few minutes until the settings page is displayed depending on the environment. In that case, reload the browser.
- If the unit is connected with Wi-Fi, only a device name can be changed. Close the settings page after changing the device name.
 - To change the device name, select "Change", and type a new device name, and then select "Apply".

2 Type a device name and then select "Next".

- Refer to the step 4 of "Using an Internet browser" (→ 10) for details on a device name.

3 Select and input the details.

- If your network requires specific settings, deselect "DHCP" to disable DHCP.
 - You can use specific IP address, subnet mask, default gateway, primary DNS, etc.

4 Select "Connect" to apply the settings.

- When the connection is established, the network indicator (blue) lights up.

Network standby

This function maintains network connectivity even while this unit is turned off. By enabling this function, you can connect to a network soon after turning on this unit.

- To disable the function, follow the steps below:
 - ① Touch and hold [NET] and [VOICE] for at least 4 seconds.

- ② Check that the operation indicator blinks twice.

- The network standby function is enabled if the operation indicator blinks once.

To use this unit with the network standby

function disabled, touch [] to switch to "Bluetooth®" mode before turning off this unit each time.

If you turn off this unit in Network mode, the network standby function is automatically enabled.



- Enabling the network standby function results in faster battery consumption. You can disable it only while this unit is running on the battery so that power consumption is minimized. (→ 19)
- If this function is set to on, the network (wired LAN/Wi-Fi) remains active even in standby mode.
 - The power consumption in standby mode will increase. When using the rechargeable battery, be careful of its remaining capacity.
- If this function is set to off, the network (wired LAN/Wi-Fi) is disabled in standby mode.
 - The network (wired LAN/Wi-Fi) will be enabled when the unit is turned on.
 - The power consumption in standby mode will be reduced.
- If the network indicator is blinking in blue and red, wait until the blinking stops.
- When the unit is turned on by this feature, the beginning part of the music may not be played back.
- Depending on the app, the conditions for activating this function may differ.
- The unit may not turn on even when selected as the output speakers. In that case, start playback on the connected device.

Network reset

Restore the default network settings.

Touch and hold [NET] and [1] for at least 4 seconds.

- The network indicator starts blinking blue/red.



- This function is disabled when this system is connected with a LAN cable.

Streaming music over the network

You can stream music from your devices or online music services to this unit and other speakers powered by AllPlay.
You can also stream music source of this system to other speakers powered by AllPlay.

Streaming music on network devices

You can use the AllPlay function to stream music from the device on the network to this system's speakers by using the app "Panasonic Music Streaming" (free of charge), etc.

- **iOS** : App Store
- **Android** : Google Play



The operations and on-screen display items, etc. of the app "Panasonic Music Streaming" are subject to change.

For the latest information, visit

<http://panasonic.jp/support/global/cs/audio/app/>
More apps are available. For details, visit

<http://www.panasonic.com/global/consumer/homeav/allseries/service>
(These sites are in English only.)

Preparation

- Complete the network settings. (→ 9)
- Connect the following devices to the same network as this system.
 - Device with "Panasonic Music Streaming", etc. installed
 - Device containing music

The following steps are based on "Panasonic Music Streaming".

1 Turn this unit on.

- Check that the network indicator (blue) lights up.
 - If the network indicator is blinking in blue and red, wait until the blinking stops.

2 Start the app "Panasonic Music Streaming".

- Always use the latest version of the app.

3 From "Speaker", select this system as the output speakers.

- If you have multiple speakers powered by AllPlay, you can enjoy synchronised sound from them. To group speakers, drag "⊞" of the desired speakers over each other.
 - You can change the speaker mode setting for the unit to left or right channel to make stereo pairing.
 - You can also play different songs on other speakers powered by AllPlay at the same time.
 - The number of speakers powered by AllPlay that can perform playback at the same time differs depending on the situation of use.
 - When you turn off one of the speakers powered by AllPlay, other speakers in the same group may stop the playback.

4 Select a music source.

5 Select a song.

■ Enhancing the sound

When using the app "Panasonic Music Streaming", you can use the below sound functions from the settings of the app.

- Equaliser
- L/R channel settings
- Voice mode (→ 6)



- This system will be displayed as "Panasonic ALL05" if the device name is not set.
- About supported format, refer to "Audio support format" (→ 25).
- Depending on the contents and the connected equipment, playback may not be performed properly.
- Ensure to stop playback on your device before turning it off.

Streaming online music

This unit is compatible with several music services.

Visit the following website for the compatibility information.

<http://www.panasonic.com/global/consumer/homeav/allseries/service>

Preparation

- Make sure that the network is connected to the Internet.
- Connect a device with a compatible app installed to the same network as this system.

1 Turn this unit on.

- Check that the network indicator (blue) lights up.
 - If the network indicator is blinking in blue and red, wait until the blinking stops.

2 Start the app, and select a song to playback.

■ Using Spotify

- You will need Spotify Premium. For details, visit the following website.
www.spotify.com/connect/

After step 2

3 Select the song's cover art image on the playback screen.

4 From “ - To enjoy synchronised sound from the multiple speakers powered by AllPlay, you need to group the speakers using the app “Panasonic Music Streaming”. (→ 13)

■ Using online music services other than Spotify

After step 2

3 From “ - Depending on the service, you might need to open full screen player to display “ - If you have multiple speakers powered by AllPlay, you can enjoy synchronised sound from them. Select “Group” and then select the speakers to group.



- This system will be displayed as “Panasonic ALL05” if the device name is not set.
- Registration/subscription is required.
- Fees may apply.
- Services, icons, and specifications are subject to change.
- For details, visit the individual music service's website.

Presetting the favourite stations (Only when playback using internet radio app “AllPlay Radio”)

This unit is compatible with the Qualcomm® AllPlay™ Radio powered by TuneIn.

You can preset the favourite stations when playback using internet radio app “AllPlay Radio”.

Qualcomm® AllPlay™ Radio powered by TuneIn is a product of Qualcomm Connected Experiences, Inc.

You can preset up to 6 channels.

- A station previously stored is overwritten when another station is stored in the same channel preset.

Preparation

- Make sure that the network is connected to the Internet.
- Connect a device with an “AllPlay Radio” app installed to the same network as this unit.

1 Turn this unit on.

- Check that the network indicator (blue) lights up.
 - If the network indicator is blinking in blue and red, wait until the blinking stops.

2 Start the app “AllPlay Radio”, and select a station to playback.

- Always use the latest version of the app.

3 Touch and hold one of the internet radio preset channel switches ([1] to [6]) on the unit for at least 4 seconds to preset the selected station.

The selected channel number will light up.

■ Listening to a preset channel

Touch one of the internet radio preset channel switches ([1] to [6]) on the unit.
The selected channel number will light up.



- If the selected preset channel has not been preset or this unit is not connected to the network, the selected channel number will not light up.
- It may take some time until sound is output after a station is selected.

Streaming music on this system to other speakers powered by AllPlay

You can use the app “Panasonic Music Streaming” (→ 13) to stream this system’s music source (Bluetooth® source, registered broadcasting station, etc.) to other speakers powered by AllPlay.

e.g.,

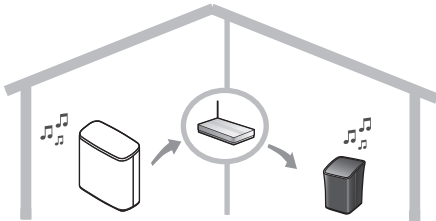

Preparation

- Complete the network settings. (→ 9)
- Prepare the desired audio source on this system (e.g. turn on the connected device, etc.).
- Install your device with the app “Panasonic Music Streaming”.
- Connect your device and your speakers powered by AllPlay to the same network as this system.

1 Turn this unit on.

- Check that the network indicator (blue) lights up.
 - If the network indicator is blinking in blue and red, wait until the blinking stops.

2 Start the app “Panasonic Music Streaming”.

- Always use the latest version of the app.

3 From “Speaker”, select the speaker to stream this system’s audio.

- To stream this system’s audio to other speakers powered by AllPlay, drag “” of the desired speakers over each other.

4 Select your desired music source from the list.

5 Select this system.

The device will start to read the selected music source’s information from this system.

- This system will change to the selector mode for the selected music source.
- The speaker selected in step 3 and this system will be automatically grouped together.
- Depending on the selected music source, playback may start. If a content list appears on your device, select the desired content to start playback.
- You can change the speaker mode setting for the unit to left or right channel to make stereo pairing.
- The number of speakers powered by AllPlay that can perform playback at the same time differs depending on the situation of use.
- When you turn off one of the speakers powered by AllPlay, other speakers in the same group may stop the playback.



- This system will be displayed as “Panasonic ALL05” if the device name is not set.
- When enjoying video contents with this function, the video and audio output may not be synchronised.

Bluetooth® operations

By using the Bluetooth® connection, you can listen to the sound of the Bluetooth® audio device wirelessly.

- Refer to the operating instructions of the Bluetooth® device for further instruction on how to connect a Bluetooth® device.

Registering and connecting Bluetooth® devices

Preparation

- Turn on the Bluetooth® feature of the device and place the device near this unit.

■ Bluetooth® pairing

1 Touch [].

- If [] blinks fast, go to step 3.

2 To enter pairing mode, touch and hold [] for at least 2 seconds.

- [] indicator blinks faster.

3 Select “SC-ALL05” from the Bluetooth® device’s menu.

- The MAC address “□□□□□□” (“□” stands for a character that is unique to each set.) may be displayed before “SC-ALL05” is displayed.
- [] lights up and the device is connected to this unit.

4 Start playback on the Bluetooth® device.

■ Connecting a paired Bluetooth® device



1 Touch [].

- [] blinks slowly.

2 Select “SC-ALL05” from the Bluetooth® device’s menu.

3 Start playback on the Bluetooth® device.

■ Disconnecting a Bluetooth® device

- Touch and hold [] for at least 2 seconds.
 - [] blinks slowly.
- Turn off this unit or the device.
- Stop/disable the Bluetooth® transmission of the device.



- If prompted for the passkey, input “0000”.
- You can register multiple Bluetooth® devices with this unit. If you register 9 or more devices, existing device registration data may be overwritten and erased, starting with the oldest data.
- In Bluetooth® mode, this unit will try to connect to the last-used Bluetooth® device. If the connection attempt fails, try to establish a connection again.
- When the unit is selected as the speakers powered by AllPlay, the audio source will change to the network.
- Bluetooth® cannot be selected as the audio source when the unit is waiting for the WPS PUSH or WPS PIN code connection.
- This unit can only be connected to one device at a time.
- When enjoying video contents with this function, the video and audio output may not be synchronised.

Bluetooth® standby

This function allows you to connect a paired Bluetooth® device when this unit is in standby mode.

This unit will be turned on automatically when you connect a paired Bluetooth® device.

Touch and hold [] and [1] for at least 4 seconds.

- The operation indicator blinks according to the setting.

Number of blinks	Setting
1	Enabled
2	Disabled



- If "Enabled" is selected, this unit automatically turns on when it connects to a registered Bluetooth® device.
 - Power consumption in standby mode will increase.
- You can not set this function during the network indicator blinking in blue and red.
- The factory default is "Disabled".

Bluetooth® input level

If the sound input level from the Bluetooth® device is too low, change the input level setting.

Preparation

- Make sure that a Bluetooth® device is already connected with this unit. (→ 16)

Touch and hold [] and [VOL -] for at least 4 seconds.

- The operation indicator blinks to show the Bluetooth® input level.

Number of blinks	Bluetooth® input level
1	Low
2	Middle
3	High



- You can not set this function during the network indicator blinking in blue and red.
- Select "Low" if the sound is distorted.
- The factory default is "Low".

Firmware updates

Occasionally, Panasonic may release updated firmware for this unit that may add or improve the way a feature operates. These updates are available free of charge.

You can also update the firmware from a pop-up prompting you to do so on-screen within the app "Panasonic Music Streaming" (version 3.1.0 or later) (→ 13). For details on the app, refer to the site below.
<http://panasonic.jp/support/global/cs/audio/app/>
(This site is in English only.)



DO NOT DISCONNECT the AC mains lead while [NET] blinks slowly.

- During the update process, no other operations can be performed.

Automatic updates

When this function is on, the unit will check and update the firmware automatically.

Preparation

- Connect this unit and the AC adaptor (→ 8).
- Download and start the app "Panasonic Music Streaming" (free of charge) on your smartphone.
- Connect this unit to the network. (→ 9)
 - Make sure that the network is connected to the Internet.
- If the network indicator is blinking in blue and red, wait for it to light up in blue.

■ To turn on the function

Touch and hold [NET] and [VOL +] for at least 4 seconds.

- The operation indicator blinks once.



- The firmware is automatically updated while this unit is turned off.
- During the update process, [NET] blinks slowly.
- To turn off the function, touch and hold [NET] and [VOL -] for at least 4 seconds.
(The operation indicator blinks twice.)
- The factory default is off.

Manual updates

Preparation

- Connect this unit and the AC adaptor (→ 8).
- Connect this unit to the network. (→ 9)
 - Make sure that the network is connected to the Internet.
- If the network indicator is blinking in blue and red, wait for it to light up in blue.

1 Touch and hold [NET] and  for at least 5 seconds till the operation indicator (amber) starts to blink.

- The operation indicator blinks.

2 While continuing to hold [NET] and , touch [VOICE].

- During the update process, [NET] blinks slowly.

3 After the update has finished, [NET] lights up for at least 3 seconds.

- The unit will restart and the network indicator (blue/red) blinks alternately.



- An update will require about 8 minutes. It may take longer or may not work properly depending on the connection environment.
- If there are no updates, the operation indicator lights off.
- Updates cannot be performed while this unit is running only on the built-in battery.

Others

Operation sound setting

As a factory default, there will be a beep sound when you touch the switch on the unit.

Touch and hold [1] and [2] for at least 4 seconds.

- The operation indicator blinks according to the setting.

Number of blinks	Setting
1	Enabled
2	Disabled



- The default setting is "Enabled".

Dimmer function

You can change the brightness of the display and indicators.

Touch and hold [VOICE] for at least 4 seconds.

- The operation indicator blinks according to the setting.

Number of blinks	Brightness
1	Bright
2	Moderately dim
3	Dim



- The default setting is "Bright".

Changing the standby mode setting that works when this unit is running on the battery

Change the standby mode setting that is applied to the network standby function (→ 12) or Bluetooth® standby function (→ 17) when this unit is running on the battery.

Touch and hold [NET] and [▶/||] for at least 4 seconds.

- The operation indicator blinks according to the setting.

Number of blinks	Setting
1	Enabled
2	Disabled

These settings work only when this unit is running on the battery.

- The default setting is "Enabled".

If you enable this function, the setting selected for the network standby function (→ 12) or Bluetooth® standby function (→ 17) will work.

- If the network standby function is enabled, the network indicator blinks thrice in purple when you turn off this unit.

If you disable this function, this unit does not switch to standby mode regardless of the setting selected for the network standby function (→ 12) or Bluetooth® standby function (→ 17).



- If you enable the standby mode setting that works when this unit is running on the battery, faster battery consumption will result even while this unit is turned off. In addition, the setting will be cancelled when the battery becomes empty.
- Battery life when this unit is off (standby)* (When this unit is running on the battery)
 - If the standby mode setting is disabled: about 1 year
 - If the standby mode setting is enabled: about 13 hours
- ※ From a fully charged state to a fully depleted state
- The standby mode setting is enabled by default to allow you to connect this unit to a network with ease. To reduce power consumption, disable the setting. Please note that it will take about 1 minute to connect to a network after you turn on this unit if you disable the setting.

Wi-Fi signal strength

To check the Wi-Fi signal strength where the unit is located.

Touch and hold [NET] and [2] for at least 4 seconds.

- The operation indicator (amber) blinks once and then blinks again to show the Wi-Fi signal strength.

Number of blinks	Wi-Fi signal strength
0	Weak
1	
2	
3	Strong



- If the network indicator is blinking in blue and red, wait until the blinking stops.
- If the Wi-Fi signal strength cannot be checked, deselect the unit from speakers powered by AllPlay, and try again.

IP/MAC address

To check the unit's IP address and the MAC address.

Preparation

- Connect this unit to the network. (→ 9)
- Download the app "Panasonic Music Streaming". (→ 13)

1 Start the app "Panasonic Music Streaming".

2 From "Speaker", select "".

3 Select this unit.



- This unit will be displayed as "Panasonic ALL05" if the device name is not set.
- If the network indicator is blinking in blue and red, wait until the blinking stops.

Troubleshooting

Before requesting service, make the following checks.

If the problem remains unresolved, consult your dealer for instructions.

Do you have the latest firmware installed?

- Panasonic is constantly improving the unit's firmware to ensure that our customers are enjoying the latest technology. (→ 18)

For further dedicated help, support and advice about your ALL Series product please visit:

<http://panasonic.jp/support/global/cs/audio/ALL/index.html>

(This site is in English only.)

General

To return all settings to the factory defaults

- ① Turn this unit on.
 - If the network indicator is blinking in blue and red, proceed to the next step after the blinking stops.
- ② Touch and hold [⏻/|].
 - The operation indicator (amber) starts to blink.
- ③ While continuing to hold [⏻/|], touch [NET].
 - The operation indicator (amber) blinks 4 times.

Cannot turn on the unit.

- After connecting the AC mains lead, wait about 10 seconds before turning on the unit.
- Disconnect and reconnect the AC mains lead first. If the problem persists, press [RESET] with a paper clip or similar object. (→ 7)

Humming heard during playback.

- There are cords of other appliances or fluorescent light near the unit's AC mains lead. Turn the appliances off or keep them away from the AC mains lead.

The network indicator does not stop blinking in blue and red.

- The unit needs to be repaired. Consult your dealer.

The unit does not work as described in the Operating Instructions.

- Update the unit's firmware. (→ 18)

Bluetooth®

Pairing cannot be done.

- Check the Bluetooth® device condition.

The device cannot be connected.

- The pairing of the device was unsuccessful or the registration has been replaced. Try pairing the device again. (→ 16)
- This system might be connected to a different device. Disconnect the other device and try pairing the device again.

The device is connected but audio cannot be heard through this system.

- For some Bluetooth® devices, you have to set the audio output to "SC-ALL05" manually. Read the operating instructions for the device for details.

Connection is interrupted.

Sound is interrupted/sound skips/there is a lot of noise.

- Remove any obstacle between this system and the device.
- Other devices that use the 2.4 GHz frequency band (wireless router, microwaves, cordless phones, etc.) are interfering. Bring the Bluetooth® device closer to this system and distance it from the other devices.

If the above does not fix the problem, you may be able to fix the problem by reconnecting this unit and the Bluetooth® device. (→ 16)

Firmware updates

[NET] keeps blinking twice.

- This unit is not connected to the network. Touch any switch, and then check the network connection. (→ 9)

[NET] keeps blinking three times.

- The update has been failed. Touch any switch, and then try again.
- Disconnect and reconnect the AC mains lead first, and then retry the firmware update.

[NET] keeps blinking fast.

- An error has occurred. Disconnect the AC mains lead and reconnect it. Turn the unit on and try again.

Network

Cannot connect to the network.

- This unit's Wi-Fi security supports WPA2™ only. Your wireless router must therefore be WPA2™ compatible. For details on the security supported by your router and how to change the settings, please refer to the operating instructions or contact your Internet service provider.
- If the network is set to be invisible, make the network visible while you set up the network for this unit or make a wired LAN connection. (→ 11)
- Make sure that the multicast function on the wireless router is enabled.
- Depending on the routers, WPS button may not work. Try other methods. (→ 9)

The network indicator (red) keeps blinking.

- This unit is not connected to the network. Check the network connection. (→ 9)

Cannot select this unit as the output speakers.

- Make sure that the devices are connected to the same network as this unit.
- Reconnect the devices to the network.
- Turn off and then on the wireless router.

Playback does not start.

The sound is interrupted.

- If using the 2.4 GHz band on the wireless router, simultaneous use with other 2.4 GHz devices, such as microwaves, cordless telephones, etc., may result in connection interruptions. Increase the distance between this unit and these devices.
 - If your wireless router supports 5 GHz band, try using the 5 GHz band.
 - To change to the 5 GHz band, perform a network reset (→ 12), and redo the network settings using an Internet browser (→ 10). On the step 5, make sure to select your network name (SSID) for the 5 GHz band.
- Do not place this unit inside a metal cabinet, for it might block the Wi-Fi signal.
- Place this unit closer to the wireless router.
- If several wireless devices are simultaneously using the same network as this unit, try turning off the other devices or reducing their network usage.
- Reconnect the devices to the network.
- Turn off and then on the wireless router.
- Try a wired LAN connection. (→ 11)

Disposing of this unit

When disposing of this unit, remove the built-in battery to support battery recycling.

■ How to remove the battery

Never disassemble this product, except for when disposing of it.

● **The illustrations below are not intended for repair of this unit, but for its disposal. Once you disassemble this unit, it can never be reassembled.**

- Before disassembling this unit, discharge the battery completely.
- If you have trouble removing the battery, contact your dealer or nearest service centre.

1 Remove the rubber feet from the bottom of this unit. (×2)

- Insert a flat-head screwdriver (commercially available) or similar tool to prise out and remove the rubber feet.

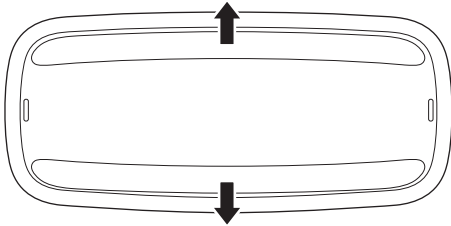

2 Remove the screws (×8), and then the cover.

- Use a commercially available screwdriver (+; size: No. 1) to remove the screws.

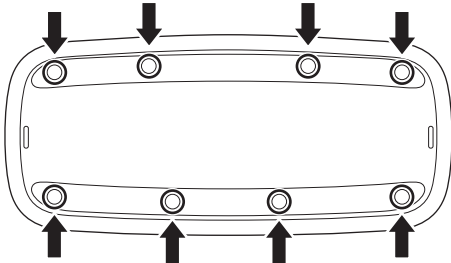

3 Remove the battery.

- ① Hold the wires to pull out the connector.
- ② Remove the battery.

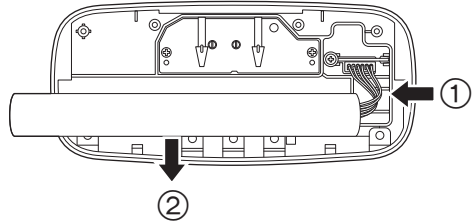

■ Handling of the used rechargeable battery

- Insulate the terminals with cellophane tape or similar material.
- Do not disassemble.
- When the battery becomes unusable, bring it to a facility that accepts used rechargeable batteries instead of throwing it away.

■ To dispose or transfer this unit

The unit may keep the user settings information in the unit. If you discard this unit either by disposal or transfer, then follow the procedure to return all the settings to the factory defaults to delete the user settings.

(→ 21, “To return all settings to the factory defaults”)

- The operation history may be recorded in the memory of this unit.

About Bluetooth®

Panasonic bears no responsibility for data and/or information that is compromised during a wireless transmission.

■ Frequency band used

This system uses the 2.4 GHz frequency band.

■ Certification of this device

- This system conforms to frequency restrictions and has received certification based on frequency laws. Thus, a wireless permit is not necessary.
- The actions below are punishable by law in some countries:
 - Taking apart or modifying the unit.
 - Removing specification indications.

■ Restrictions of use

- Wireless transmission and/or usage with all Bluetooth® equipped devices is not guaranteed.
- All devices must conform to standards set by Bluetooth SIG, Inc.
- Depending on the specifications and settings of a device, it can fail to connect or some operations can be different.
- This system supports Bluetooth® security features. But depending on the operating environment and/or settings, this security is possibly not sufficient. Transmit data wirelessly to this system with caution.
- This system cannot transmit data to a Bluetooth® device.

■ Range of use

Use this device at a maximum range of 10 m. The range can decrease depending on the environment, obstacles or interference.

■ Interference from other devices

- This system may not function properly and troubles such as noise and sound jumps may arise due to radio wave interference if this system is located too close to other Bluetooth® devices or the devices that use the 2.4 GHz band.
- This system may not function properly if radio waves from a nearby broadcasting station, etc. are too strong.

■ Intended usage

- This system is for normal, general use only.
- Do not use this system near an equipment or in an environment that is sensitive to radio frequency interference (example: airports, hospitals, laboratories, etc.).

Specifications

■ GENERAL

Power supply

DC 12 V, 3 A

Internal Battery 7.28 V (Li-ion 2950 mAh)

Power consumption

11 W

Power consumption in standby mode (Off mode)

Approx. 0.25 W

(When "Network standby" is on)

Approx. 1.9 W

Dimensions

(W×H×D) Approx. 170 mm×179 mm×77 mm

Dimensions (not including protrusion)

(W×H×D) Approx. 170 mm×178 mm×76 mm

Mass

Approx. 1.5 kg

Operating temperature range

0 °C to +40 °C

Charging temperature range

+10 °C to +35 °C

Operating humidity range

35 % to 80 % RH (no condensation)

Water Proof

IPX5/IPX7 equivalent

■ AMPLIFIER SECTION

RMS output power (AC Adaptor)

Front Ch (both ch driven)

10 W per channel (6 Ω), 1 kHz, 10 % THD

Total power

20 W

RMS output power (Battery)

Front Ch (both ch driven)

4 W per channel (6 Ω), 1 kHz, 10 % THD

Total power

8 W

■ SPEAKER SECTION

FRONT SPEAKER (L/R)

Speaker unit(s)

Full range

6.5 cm cone type×2

Passive Radiator

6.5 cm×2

Impedance

6 Ω

■ TERMINALS SECTION

DC IN	12 V, 3 A
LAN port	10 Base-T/100 Base-TX

■ ACCESSORIES SECTION

AC Adaptor

INPUT	AC 100 V to 240 V, 50/60 Hz, 1.2 A
OUTPUT	DC 12 V, 3 A

■ Bluetooth® SECTION

Bluetooth® system specification

Bluetooth® Ver.3.0

Wireless equipment classification

Class 2 (2.5 mW)

Supported profiles

A2DP, AVRCP

Frequency band

2.4 GHz band FH-SS

Operating distance

Approx. 10 m Line of Sight*1

Supported codec

SBC

■ Wi-Fi SECTION

Wi-Fi

WLAN Standard IEEE802.11a/b/g/n

Frequency range 2.4 GHz band (1-11 ch)/
5 GHz band (36-165 ch)

Security WPA2™

WPS version Version 2.0

■ Audio support format (AllPlay)

MP3/AAC

Sampling frequency 32/44.1/48 kHz

Audio word size 16 bits

Channel count 2 ch

Bit-rate 8-320 kbps

FLAC*2/ALAC/WAV

Sampling frequency 32/44.1/48/88.2/96/176.4/
192 kHz

Audio word size 16 bits/24 bits

Channel count 2 ch



- Specifications are subject to change without notice.
 - Total harmonic distortion is measured by a digital spectrum analyzer.
- ※1 Prospect communication distance.
Measurement environment.
(Temperature 25 °C, Height 1.0 m)
- ※2 Uncompressed FLAC files may not operate correctly.

CE 0560 ⓘ

Declaration of Conformity (DoC)

Hereby, "Panasonic Corporation" declares that this product is in compliance with the essential requirements and other relevant provisions of Directive 1999/5/EC.

Customers can download a copy of the original DoC to our R&TTE products from our DoC server:
<http://www.doc.panasonic.de>

Contact to Authorised Representative:

Panasonic Marketing Europe GmbH, Panasonic Testing Centre, Winsbergring 11, 22525 Hamburg, Germany

This product is in compliance with the radio standards of the following countries.

GB, DE, AT, BE, DK, SE, FR, IT, ES, NL, FI, GR, PT, PL, HU, CZ, SK, EE, LV, LT, SI, BG, RO, MT, CY, IE, LU, HR, NO, CH, IS, LI, TR

The WLAN feature of this product shall exclusively be used inside buildings.

This product on purpose to connect to access point of 2.4 GHz or 5 GHz WLAN.



Class II equipment (The construction of the product is double-insulated.)

Product Identification Marking is located on the bottom of the unit.

Licenses

Various proper names contained within this document, such as company and brand names, are trademarks or registered trademarks of their respective owners.

Please note that the ™ and ® symbols are not indicated in some portions of this document.

<p>Qualcomm is a trademark of Qualcomm Incorporated, registered in the United States, and other countries and used with permission. AllPlay is a trademark of Qualcomm Connected Experiences, Inc., and used with permission. TuneIn is a trademark of TuneIn Inc., registered in the United States and other countries and used with permission.</p>
<p>The Spotify software is subject to third party licenses found here: www.spotify.com/connect/third-party-licenses</p>
<p>The Bluetooth® word mark and logos are registered trademarks owned by Bluetooth SIG, Inc. and any use of such marks by Panasonic Corporation is under license. Other trademarks and trade names are those of their respective owners.</p>
<p>Google Play and Android are trademarks of Google Inc.</p>
<p>App Store is a service mark of Apple Inc.</p>
<div style="text-align: center;">  </div> <p>The Wi-Fi CERTIFIED™ Logo is a certification mark of Wi-Fi Alliance®. The Wi-Fi Protected Setup™ Identifier mark is a certification mark of Wi-Fi Alliance®. “Wi-Fi®” is a registered trademark of Wi-Fi Alliance®. “Wi-Fi Protected Setup™”, “WPA™”, and “WPA2™” are trademarks of Wi-Fi Alliance®.</p>
<p>Windows is a trademark or a registered trademark of Microsoft Corporation in the United States and other countries.</p>
<p>MPEG Layer-3 audio coding technology licensed from Fraunhofer IIS and Thomson.</p>
<p>iPad, iPhone, iPod, and iPod touch are trademarks of Apple Inc., registered in the U.S. and other countries.</p>

FLAC Decoder
 Copyright (C)
 2000,2001,2002,2003,2004,2005,2006,2007,2008,2009
 Josh Coalson Redistribution and use in source and binary forms, with or without modification, are permitted provided that the following conditions are met:

- Redistributions of source code must retain the above copyright notice, this list of conditions and the following disclaimer.
- Redistributions in binary form must reproduce the above copyright notice, this list of conditions and the following disclaimer in the documentation and/or other materials provided with the distribution.
- Neither the name of the Xiph.org Foundation nor the names of its contributors may be used to endorse or promote products derived from this software without specific prior written permission.

THIS SOFTWARE IS PROVIDED BY THE COPYRIGHT HOLDERS AND CONTRIBUTORS "AS IS" AND ANY EXPRESS OR IMPLIED WARRANTIES, INCLUDING, BUT NOT LIMITED TO, THE IMPLIED WARRANTIES OF MERCHANTABILITY AND FITNESS FOR A PARTICULAR PURPOSE ARE DISCLAIMED. IN NO EVENT SHALL THE FOUNDATION OR CONTRIBUTORS BE LIABLE FOR ANY DIRECT, INDIRECT, INCIDENTAL, SPECIAL, EXEMPLARY, OR CONSEQUENTIAL DAMAGES (INCLUDING, BUT NOT LIMITED TO, PROCUREMENT OF SUBSTITUTE GOODS OR SERVICES; LOSS OF USE, DATA, OR PROFITS; OR BUSINESS INTERRUPTION) HOWEVER CAUSED AND ON ANY THEORY OF LIABILITY, WHETHER IN CONTRACT, STRICT LIABILITY, OR TORT (INCLUDING NEGLIGENCE OR OTHERWISE) ARISING IN ANY WAY OUT OF THE USE OF THIS SOFTWARE, EVEN IF ADVISED OF THE POSSIBILITY OF SUCH DAMAGE.



Disposal of Old Equipment Only for European Union and countries with recycling systems

This symbol on the products, packaging, and/or accompanying documents means that used electrical and electronic products must not be mixed with general household waste.

For proper treatment, recovery and recycling of old products, please take them to applicable collection points in accordance with your national legislation.

By disposing of them correctly, you will help to save valuable resources and prevent any potential negative effects on human health and the environment.

For more information about collection and recycling, please contact your local municipality.

Penalties may be applicable for incorrect disposal of this waste, in accordance with national legislation.

This product incorporates the following software:

- (1) the software developed independently by or for Panasonic Corporation,
- (2) the software owned by third party and licensed to Panasonic Corporation,
- (3) the software licensed under the GNU General Public License, Version 2.0 (GPL V2.0),
- (4) the software licensed under the GNU LESSER General Public License, Version 2.1 (LGPL V2.1), and/or
- (5) open source software other than the software licensed under the GPL V2.0 and/or LGPL V2.1.

The software categorized as (3) - (5) are distributed in the hope that it will be useful, but WITHOUT ANY WARRANTY, without even the implied warranty of MERCHANTABILITY or FITNESS FOR A PARTICULAR PURPOSE.

At least three (3) years from delivery of this product, Panasonic will give to any third party who contacts us at the contact information provided below, for a charge no more than our cost of physically performing source code distribution, a complete machine-readable copy of the corresponding source code covered under GPL V2.0, LGPL V2.1 or the other licenses with the obligation to do so, as well as the respective copyright notice thereto.

Contact information:

oss-ct-request@gg.jp panasonic.com

The source code and the copyright notice are also available for free in our website below.

<http://panasonic.net/avc/oss/>

GNU LESSER GENERAL PUBLIC LICENSE

Version 2.1, February 1999

Copyright (C) 1991, 1999 Free Software Foundation, Inc.
51 Franklin Street, Fifth Floor, Boston, MA 02110-1301 USA
Everyone is permitted to copy and distribute verbatim copies of this license document, but changing it is not allowed.

[This is the first released version of the Lesser GPL. It also counts as the successor of the GNU Library Public License, version 2, hence the version number 2.1.]

Preamble

The licenses for most software are designed to take away your freedom to share and change it. By contrast, the GNU General Public Licenses are intended to guarantee your freedom to share and change free software—to make sure the software is free for all its users.

This license, the Lesser General Public License, applies to some specially designated software packages—typically libraries—of the Free Software Foundation and other authors who decide to use it. You can use it too, but we suggest you first think carefully about whether this license or the ordinary General Public License is the better strategy to use in any particular case, based on the explanations below.

When we speak of free software, we are referring to freedom of use, not price. Our General Public Licenses are designed to make sure that you have the freedom to distribute copies of free software (and charge for this service if you wish); that you receive source code or can get it if you want it; that you can change the software and use pieces of it in new free programs; and that you are informed that you can do these things.

To protect your rights, we need to make restrictions that forbid distributors to deny you these rights or to ask you to surrender these rights. These restrictions translate to certain responsibilities for you if you distribute copies of the library or if you modify it.

For example, if you distribute copies of the library, whether gratis or for a fee, you must give the recipients all the rights that we gave you. You must make sure that they, too, receive or can get the source code. If you link other code with the library, you must provide complete object files to the recipients, so that they can relink them with the library after making changes to the library and recompiling it. And you must show them these terms so they know their rights.

We protect your rights with a two-step method: (1) we copyright the library, and (2) we offer you this license, which gives you legal permission to copy, distribute and/or modify the library.

To protect each distributor, we want to make it very clear that there is no warranty for the free library. Also, if the library is modified by someone else and passed on, the recipients should know that what they have is not the original version, so that the original author's reputation will not be affected by problems that might be introduced by others.

Finally, software patents pose a constant threat to the existence of any free program. We wish to make sure that a company cannot effectively restrict the users of a free program by obtaining a restrictive license from a patent holder. Therefore, we insist that any patent license obtained for a version of the library must be consistent with the full freedom of use specified in this license.

Most GNU software, including some libraries, is covered by the ordinary GNU General Public License. This license, the GNU Lesser General Public License, applies to certain designated libraries, and is quite different from the ordinary General Public License. We use this license for certain libraries in order to permit linking those libraries into non-free programs.

When a program is linked with a library, whether statically or using a shared library, the combination of the two is legally speaking a combined work, a derivative of the original library. The ordinary General Public License therefore permits such linking only if the entire combination fits its criteria of freedom. The

Lesser General Public License permits more lax criteria for linking other code with the library.

We call this license the "Lesser" General Public License because it does Less to protect the user's freedom than the ordinary General Public License. It also provides other free software developers Less of an advantage over competing non-free programs. These disadvantages are the reason we use the ordinary General Public License for many libraries. However, the Lesser license provides advantages in certain special circumstances.

For example, on rare occasions, there may be a special need to encourage the widest possible use of a certain library, so that it becomes a de-facto standard. To achieve this, non-free programs must be allowed to use the library. A more frequent case is that a free library does the same job as widely used non-free libraries. In this case, there is little to gain by limiting the free library to free software only, so we use the Lesser General Public License.

In other cases, permission to use a particular library in non-free programs enables a greater number of people to use a large body of free software. For example, permission to use the GNU C Library in non-free programs enables many more people to use the whole GNU operating system, as well as its variant, the GNU/Linux operating system.

Although the Lesser General Public License is Less protective of the users' freedom, it does ensure that the user of a program that is linked with the Library has the freedom and the wherewithal to run that program using a modified version of the Library.

The precise terms and conditions for copying, distribution and modification follow. Pay close attention to the difference between a "work based on the library" and a "work that uses the library". The former contains code derived from the library, whereas the latter must be combined with the library in order to run.

GNU LESSER GENERAL PUBLIC LICENSE TERMS AND CONDITIONS FOR COPYING, DISTRIBUTION AND MODIFICATION

0. This License Agreement applies to any software library or other program which contains a notice placed by the copyright holder or other authorized party saying it may be distributed under the terms of this Lesser General Public License (also called "this License"). Each licensee is addressed as "you".

A "library" means a collection of software functions and/or data prepared so as to be conveniently linked with application programs (which use some of those functions and data) to form executables.

The "Library", below, refers to any such software library or work which has been distributed under these terms. A "work based on the Library" means either the Library or any derivative work under copyright law: that is to say, a work containing the Library or a portion of it, either verbatim or with modifications and/or translated straightforwardly into another language. (Hereinafter, translation is included without limitation in the term "modification".)

"Source code" for a work means the preferred form of the work for making modifications to it. For a library, complete source code means all the source code for all modules it contains, plus any associated interface definition files, plus the scripts used to control compilation and installation of the library.

Activities other than copying, distribution and modification are not covered by this License; they are outside its scope. The act of running a program using the Library is not restricted, and output from such a program is covered only if its contents constitute a work based on the Library (independent of the use of the Library in a tool for writing it). Whether that is true depends on what the Library does and what the program that uses the Library does.

1. You may copy and distribute verbatim copies of the Library's complete source code as you receive it, in any medium, provided that you conspicuously and appropriately publish on each copy an appropriate copyright notice and disclaimer of warranty; keep intact all the notices that refer to this License and to the absence of any warranty; and distribute a copy of this License along with the Library.

You may charge a fee for the physical act of transferring a copy, and you may at your option offer warranty protection in exchange for a fee.

2. You may modify your copy or copies of the Library or any portion of it, thus forming a work based on the Library, and copy and distribute such modifications or work under the terms of Section 1 above, provided that you also meet all of these conditions:

- a) The modified work must itself be a software library.
- b) You must cause the files modified to carry prominent notices stating that you changed the files and the date of any change.
- c) You must cause the whole of the work to be licensed at no charge to all third parties under the terms of this License.
- d) If a facility in the modified Library refers to a function or a table of data to be supplied by an application program that uses the facility, other than as an argument passed when the facility is invoked, then you must make a good faith effort to ensure that, in the event an application does not supply such function or table, the facility still operates, and performs whatever part of its purpose remains meaningful.

(For example, a function in a library to compute square roots has a purpose that is entirely well-defined independent of the application. Therefore, Subsection 2d requires that any application-supplied function or table used by this function must be optional: if the application does not supply it, the square root function must still compute square roots.)

These requirements apply to the modified work as a whole. If identifiable sections of that work are not derived from the Library, and can be reasonably considered independent and separate works in themselves, then this License, and its terms, do not apply to those sections when you distribute them as separate works. But when you distribute the same sections as part of a whole which is a work based on the Library, the distribution of the whole must be on the terms of this License, whose permissions for other licensees extend to the entire whole, and thus to each and every part regardless of who wrote it.

Thus, it is not the intent of this section to claim rights or contest your rights to work written entirely by you; rather, the intent is to exercise the right to control the distribution of derivative or collective works based on the Library.

In addition, mere aggregation of another work not based on the Library with the Library (or with a work based on the Library) on a volume of a storage or distribution medium does not bring the other work under the scope of this License.

3. You may opt to apply the terms of the ordinary GNU General Public License instead of this License to a given copy of the Library. To do this, you must alter all the notices that refer to this License, so that they refer to the ordinary GNU General Public License, version 2, instead of to this License. (If a newer version than version 2 of the ordinary GNU General Public License has appeared, then you can specify that version instead if you wish.) Do not make any other change in these notices.

Once this change is made in a given copy, it is irreversible for that copy, so the ordinary GNU General Public License applies to all subsequent copies and derivative works made from that copy.

This option is useful when you wish to copy part of the code of the Library into a program that is not a library.

4. You may copy and distribute the Library (or a portion or derivative of it, under Section 2) in object code or executable form under the terms of Sections 1 and 2 above provided that you accompany it with the complete corresponding machine-readable source code, which must be distributed under the terms of Sections 1 and 2 above on a medium customarily used for software interchange.

If distribution of object code is made by offering access to copy from a designated place, then offering equivalent access to copy the source code from the same place satisfies the requirement to distribute the source code, even though third parties are not compelled to copy the source along with the object code.

5. A program that contains no derivative of any portion of the Library, but is designed to work with the Library by being compiled or linked with it, is called a "work that uses the Library". Such a work, in isolation, is not a derivative work of the Library, and therefore falls outside the scope of this License.

However, linking a "work that uses the Library" with the Library creates an executable that is a derivative of the Library (because it contains portions of the Library), rather than a "work that uses the library". The executable is therefore covered by this License.

Section 6 states terms for distribution of such executables.

When a "work that uses the Library" uses material from a header file that is part of the Library, the object code for the work may be a derivative work of the Library even though the source code is not.

Whether this is true is especially significant if the work can be linked without the Library, or if the work is itself a library. The threshold for this to be true is not precisely defined by law.

If such an object file uses only numerical parameters, data structure layouts and accessors, and small macros and small inline functions (ten lines or less in length), then the use of the object file is unrestricted, regardless of whether it is legally a derivative work. (Executables containing this object code plus portions of the Library will still fall under Section 6.)

Otherwise, if the work is a derivative of the Library, you may distribute the object code for the work under the terms of Section 6.

Any executables containing that work also fall under Section 6, whether or not they are linked directly with the Library itself.

6. As an exception to the Sections above, you may also combine or link a "work that uses the Library" with the Library to produce a work containing portions of the Library, and distribute that work under terms of your choice, provided that the terms permit modification of the work for the customer's own use and reverse engineering for debugging such modifications.

You must give prominent notice with each copy of the work that the Library is used in it and that the Library and its use are covered by this License. You must supply a copy of this License. If the work during execution displays copyright notices, you must include the copyright notice for the Library among them, as well as a reference directing the user to the copy of this License. Also, you must do one of these things:

a) Accompany the work with the complete corresponding machine-readable source code for the Library including whatever changes were used in the work

(which must be distributed under Sections 1 and 2 above); and, if the work is an executable linked with the Library, with the complete machine-readable "work that uses the Library", as object code and/or source code, so that the user can modify the Library and then relink to produce a modified executable containing the modified Library. (It is understood that the user who changes the contents of definitions files in the Library will not necessarily be able to recompile the application to use the modified definitions.)

b) Use a suitable shared library mechanism for linking with the Library. A suitable mechanism is one that (1) uses at run time a copy of the library already present on the user's computer system, rather than copying library functions into the executable, and (2) will operate properly with a modified version of the library, if the user installs one, as long as the modified version is interface-compatible with the version that the work was made with.

c) Accompany the work with a written offer, valid for at least three years, to give the same user the materials specified in Subsection 6a, above, for a charge no more than the cost of performing this distribution.

d) If distribution of the work is made by offering access to copy from a designated place, offer equivalent access to copy the above specified materials from the same place.

e) Verify that the user has already received a copy of these materials or that you have already sent this user a copy.

For an executable, the required form of the "work that uses the Library" must include any data and utility programs needed for reproducing the executable from it. However, as a special exception, the materials to be distributed need not include anything that is normally distributed (in either source or binary form) with the major components (compiler, kernel, and so on) of the operating system on which the executable runs, unless that component itself accompanies the executable.

It may happen that this requirement contradicts the license restrictions of other proprietary libraries that do not normally accompany the operating system. Such a contradiction means you cannot use both them and the Library together in an executable that you distribute.

7. You may place library facilities that are a work based on the Library side-by-side in a single library together with other library facilities not covered by this License, and distribute such a combined library, provided that the separate distribution of the work based on the Library and of the other library facilities is otherwise permitted, and provided that you do these two things:

a) Accompany the combined library with a copy of the same work based on the Library, uncombined with any other library facilities. This must be distributed under the terms of the Sections above.

b) Give prominent notice with the combined library of the fact that part of it is a work based on the Library, and explaining where to find the accompanying uncombined form of the same work.

8. You may not copy, modify, sublicense, link with, or distribute the Library except as expressly provided under this License. Any attempt otherwise to copy, modify, sublicense, link with, or distribute the Library is void, and will automatically terminate your rights under this License. However, parties who have received copies, or rights, from you under this License will not have their licenses terminated so long as such parties remain in full compliance.

9. You are not required to accept this License, since you have not signed it. However, nothing else grants you permission to modify or distribute the Library or its derivative works. These actions are prohibited by law if you do not accept this License. Therefore, by modifying or distributing the Library (or any work based on the Library), you indicate your acceptance of this License to do so, and all its terms and conditions for copying, distributing or modifying the Library or works based on it.

10. Each time you redistribute the Library (or any work based on the Library), the recipient automatically receives a license from the original licensor to copy, distribute, link with or modify the Library subject to these terms and conditions. You may not impose any further restrictions on the recipients' exercise of the rights granted herein. You are not responsible for enforcing compliance by third parties with this License.

11. If, as a consequence of a court judgment or allegation of patent infringement or for any other reason (not limited to patent issues), conditions are imposed on you (whether by court order, agreement or otherwise) that contradict the conditions of this License, they do not excuse you from the conditions of this License. If you cannot distribute so as to satisfy simultaneously your obligations under this License and any other pertinent obligations, then as a consequence you may not distribute the Library at all. For example, if a patent license would not permit royalty-free redistribution of the Library by all those who receive copies directly or indirectly through you, then the only way you could satisfy both it and this License would be to refrain entirely from distribution of the Library.

If any portion of this section is held invalid or unenforceable under any particular circumstance, the balance of the section is intended to apply, and the section as a whole is intended to apply in other circumstances.

It is not the purpose of this section to induce you to infringe any patents or other property right claims or to contest validity of any such claims; this section has the

sole purpose of protecting the integrity of the free software distribution system which is implemented by public license practices. Many people have made generous contributions to the wide range of software distributed through that system in reliance on consistent application of that system; it is up to the author/donor to decide if he or she is willing to distribute software through any other system and a licensee cannot impose that choice.

This section is intended to make thoroughly clear what is believed to be a consequence of the rest of this License.

12. If the distribution and/or use of the Library is restricted in certain countries either by patents or by copyrighted interfaces, the original copyright holder who places the Library under this License may add an explicit geographical distribution limitation excluding those countries, so that distribution is permitted only in or among countries not thus excluded. In such case, this License incorporates the limitation as if written in the body of this License.

13. The Free Software Foundation may publish revised and/or new versions of the Lesser General Public License from time to time. Such new versions will be similar in spirit to the present version, but may differ in detail to address new problems or concerns.

Each version is given a distinguishing version number. If the Library specifies a version number of this License which applies to it and "any later version", you have the option of following the terms and conditions either of that version or of any later version published by the Free Software Foundation. If the Library does not specify a license version number, you may choose any version ever published by the Free Software Foundation.

14. If you wish to incorporate parts of the Library into other free programs whose distribution conditions are incompatible with these, write to the author to ask for permission. For software which is copyrighted by the Free Software Foundation, write to the Free Software Foundation; we sometimes make exceptions for this. Our decision will be guided by the two goals of preserving the free status of all derivatives of our free software and of promoting the sharing and reuse of software generally.

NO WARRANTY

15. BECAUSE THE LIBRARY IS LICENSED FREE OF CHARGE, THERE IS NO WARRANTY FOR THE LIBRARY, TO THE EXTENT PERMITTED BY APPLICABLE LAW. EXCEPT WHEN OTHERWISE STATED IN WRITING THE COPYRIGHT HOLDERS AND/OR OTHER PARTIES PROVIDE THE LIBRARY "AS IS" WITHOUT WARRANTY OF ANY KIND, EITHER EXPRESSED OR IMPLIED, INCLUDING, BUT NOT LIMITED TO, THE IMPLIED WARRANTIES OF MERCHANTABILITY AND FITNESS FOR A PARTICULAR PURPOSE. THE ENTIRE RISK AS TO THE QUALITY AND PERFORMANCE OF THE LIBRARY IS WITH YOU. SHOULD THE LIBRARY PROVE DEFECTIVE, YOU ASSUME THE COST OF ALL NECESSARY SERVICING, REPAIR OR CORRECTION.

16. IN NO EVENT UNLESS REQUIRED BY APPLICABLE LAW OR AGREED TO IN WRITING WILL ANY COPYRIGHT HOLDER, OR ANY OTHER PARTY WHO MAY MODIFY AND/OR REDISTRIBUTE THE LIBRARY AS PERMITTED ABOVE, BE LIABLE TO YOU FOR DAMAGES, INCLUDING ANY GENERAL, SPECIAL, INCIDENTAL OR CONSEQUENTIAL DAMAGES ARISING OUT OF THE USE OR INABILITY TO USE THE LIBRARY (INCLUDING BUT NOT LIMITED TO LOSS OF DATA OR DATA BEING RENDERED INACCURATE OR LOSSES SUSTAINED BY YOU OR THIRD PARTIES OR A FAILURE OF THE LIBRARY TO OPERATE WITH ANY OTHER SOFTWARE), EVEN IF SUCH HOLDER OR OTHER PARTY HAS BEEN ADVISED OF THE POSSIBILITY OF SUCH DAMAGES.

END OF TERMS AND CONDITIONS

How to Apply These Terms to Your New Libraries

If you develop a new library, and you want it to be of the greatest possible use to the public, we recommend making it free software that everyone can redistribute and change. You can do so by permitting redistribution under these terms (or, alternatively, under the terms of the ordinary General Public License).

To apply these terms, attach the following notices to the library. It is safest to attach them to the start of each source file to most effectively convey the exclusion of warranty; and each file should have at least the "copyright" line and a pointer to where the full notice is found.

<one line to give the library's name and a brief idea of what it does.>
Copyright (C) <year> <name of author>

This library is free software; you can redistribute it and/or modify it under the terms of the GNU Lesser General Public License as published by the Free Software Foundation; either version 2.1 of the License, or (at your option) any later version.

This library is distributed in the hope that it will be useful, but WITHOUT ANY WARRANTY; without even the implied warranty of MERCHANTABILITY or FITNESS FOR A PARTICULAR PURPOSE. See the GNU Lesser General Public License for more details.

You should have received a copy of the GNU Lesser General Public License along with this library; if not, write to the Free Software Foundation, Inc., 51 Franklin Street, Fifth Floor, Boston, MA 02110-1301 USA

Also add information on how to contact you by electronic and paper mail.

You should also get your employer (if you work as a programmer) or your school, if any, to sign a "copyright disclaimer" for the library, if necessary. Here is a sample; alter the names:

Yoyodyne, Inc., hereby disclaims all copyright interest in the library 'Frob' (a library for tweaking knobs) written by James Random Hacker.

<signature of Ty Coon>, 1 April 1990
Ty Coon, President of Vice

That's all there is to it!

GNU GENERAL PUBLIC LICENSE
Version 2, June 1991

Copyright (C) 1989, 1991 Free Software Foundation, Inc.,
51 Franklin Street, Fifth Floor, Boston, MA 02110-1301 USA
Everyone is permitted to copy and distribute verbatim copies of this license document, but changing it is not allowed.

Preamble

The licenses for most software are designed to take away your freedom to share and change it. By contrast, the GNU General Public License is intended to guarantee your freedom to share and change free software--to make sure the software is free for all its users. This General Public License applies to most of the Free Software Foundation's software and to any other program whose authors commit to using it. (Some other Free Software Foundation software is covered by the GNU Lesser General Public License instead.) You can apply it to your programs, too.

When we speak of free software, we are referring to freedom, not price. Our General Public Licenses are designed to make sure that you have the freedom to distribute copies of free software (and charge for this service if you wish), that you receive source code or can get it if you want it, that you can change the software or use pieces of it in new free programs; and that you know you can do these things.

To protect your rights, we need to make restrictions that forbid anyone to deny you these rights or to ask you to surrender the rights. These restrictions translate to certain responsibilities for you if you distribute copies of the software, or if you modify it.

For example, if you distribute copies of such a program, whether gratis or for a fee, you must give the recipients all the rights that you have. You must make sure that they, too, receive or can get the source code. And you must show them these terms so they know their rights.

We protect your rights with two steps: (1) copyright the software, and (2) offer you this license which gives you legal permission to copy, distribute and/or modify the software.

Also, for each author's protection and ours, we want to make certain that everyone understands that there is no warranty for this free software. If the software is modified by someone else and passed on, we want its recipients to know that what they have is not the original, so that any problems introduced by others will not reflect on the original authors' reputations.

Finally, any free program is threatened constantly by software patents. We wish to avoid the danger that redistributors of a free program will individually obtain patent licenses, in effect making the program proprietary. To prevent this, we have made it clear that any patent must be licensed for everyone's free use or not licensed at all.

The precise terms and conditions for copying, distribution and modification follow.

GNU GENERAL PUBLIC LICENSE
TERMS AND CONDITIONS FOR COPYING, DISTRIBUTION AND MODIFICATION

0. This License applies to any program or other work which contains a notice placed by the copyright holder saying it may be distributed under the terms of this General Public License. The "Program", below, refers to any such program or work, and a "work based on the Program" means either the Program or any derivative work under copyright law: that is to say, a work containing the Program or a portion of it, either verbatim or with modifications and/or translated into another language. (Hereinafter, translation is included without limitation in the term "modification".) Each licensee is addressed as "you".

Activities other than copying, distribution and modification are not covered by this License; they are outside its scope. The act of running the Program is not restricted, and the output from the Program is covered only if its contents constitute a work based on the Program (independent of having been made by running the Program). Whether that is true depends on what the Program does.

1. You may copy and distribute verbatim copies of the Program's source code as you receive it, in any medium, provided that you conspicuously and appropriately publish on each copy an appropriate copyright notice and disclaimer of warranty; keep intact all the notices that refer to this License and to the absence of any warranty; and give any other recipients of the Program a copy of this License along with the Program.

You may charge a fee for the physical act of transferring a copy, and you may at your option offer warranty protection in exchange for a fee.

2. You may modify your copy or copies of the Program or any portion of it, thus forming a work based on the Program, and copy and distribute such modifications or work under the terms of Section 1 above, provided that you also meet all of these conditions:

- a) You must cause the modified files to carry prominent notices stating that you changed the files and the date of any change.
- b) You must cause any work that you distribute or publish, that in whole or in part contains or is derived from the Program or any part thereof, to be licensed as a whole at no charge to all third parties under the terms of this License.
- c) If the modified program normally reads commands interactively when run, you must cause it, when started running for such interactive use in the most ordinary way, to print or display an announcement including an appropriate copyright notice and a notice that there is no warranty (or else, saying that you provide a warranty) and that users may redistribute the program under these conditions, and telling the user how to view a copy of this License. (Exception: if the Program itself is interactive but does not normally print such an announcement, your work based on the Program is not required to print an announcement.)

These requirements apply to the modified work as a whole. If identifiable sections of that work are not derived from the Program, and can be reasonably considered independent and separate works in themselves, then this License, and its terms, do not apply to those sections when you distribute them as separate works. But when you distribute the same sections as part of a whole which is a work based on the Program, the distribution of the whole must be on the terms of this License, whose permissions for other licensees extend to the entire whole, and thus to each and every part regardless of who wrote it.

Thus, it is not the intent of this section to claim rights or contest your rights to work written entirely by you; rather, the intent is to exercise the right to control the distribution of derivative or collective works based on the Program.

In addition, mere aggregation of another work not based on the Program with the Program (or with a work based on the Program) on a volume of a storage or distribution medium does not bring the other work under the scope of this License.

3. You may copy and distribute the Program (or a work based on it, under Section 2) in object code or executable form under the terms of Sections 1 and 2 above provided that you also do one of the following:

- a) Accompany it with the complete corresponding machine-readable source code, which must be distributed under the terms of Sections 1 and 2 above on a medium customarily used for software interchange; or,
- b) Accompany it with a written offer, valid for at least three years, to give any third party, for a charge no more than your cost of physically performing source distribution, a complete machine-readable copy of the corresponding source code, to be distributed under the terms of Sections 1 and 2 above on a medium customarily used for software interchange; or,
- c) Accompany it with the information you received as to the offer to distribute corresponding source code. (This alternative is allowed only for noncommercial distribution and only if you received the program in object code or executable form with such an offer, in accord with Subsection b above.)

The source code for a work means the preferred form of the work for making modifications to it. For an executable work, complete source code means all the source code for all modules it contains, plus any associated interface definition files, plus the scripts used to control compilation and installation of the executable. However, as a special exception, the source code distributed need not include anything that is normally distributed (in either source or binary form) with the major components (compiler, kernel, and so on) of the operating system on which the executable runs, unless that component itself accompanies the executable.

If distribution of executable or object code is made by offering access to copy from a designated place, then offering equivalent access to copy the source code from the same place counts as distribution of the source code, even though third parties are not compelled to copy the source along with the object code.

4. You may not copy, modify, sublicense, or distribute the Program except as expressly provided under this License. Any attempt otherwise to copy, modify, sublicense or distribute the Program is void, and will automatically terminate your rights under this License. However, parties who have received copies, or rights, from you under this License will not have their licenses terminated so long as such parties remain in full compliance.

5. You are not required to accept this License, since you have not signed it. However, nothing else grants you permission to modify or distribute the Program or its derivative works. These actions are prohibited by law if you do not accept this License. Therefore, by modifying or distributing the Program (or any work based on the Program), you indicate your acceptance of this License to do so, and all its terms and conditions for copying, distributing or modifying the Program or works based on it.

6. Each time you redistribute the Program (or any work based on the Program), the recipient automatically receives a license from the original licensor to copy, distribute or modify the Program subject to these terms and conditions. You may not impose any further restrictions on the recipients' exercise of the rights granted herein.

You are not responsible for enforcing compliance by third parties to this License.

7. If, as a consequence of a court judgment or allegation of patent infringement or for any other reason (not limited to patent issues), conditions are imposed on you (whether by court order, agreement or otherwise) that contradict the conditions of this License, they do not excuse you from the conditions of this License. If you cannot distribute so as to satisfy simultaneously your obligations under this License and any other pertinent obligations, then as a consequence you may not distribute the Program at all. For example, if a patent license would not permit royalty-free redistribution of the Program by all those who receive copies directly or indirectly through you, then the only way you could satisfy both it and this License would be to refrain entirely from distribution of the Program.

If any portion of this section is held invalid or unenforceable under any particular circumstance, the balance of the section is intended to apply and the section as a whole is intended to apply in other circumstances.

It is not the purpose of this section to induce you to infringe any patents or other property right claims or to contest validity of any such claims; this section has the sole purpose of protecting the integrity of the free software distribution system, which is implemented by public license practices. Many people have made generous contributions to the wide range of software distributed through that system in reliance on consistent application of that system; it is up to the author/donor to decide if he or she is willing to distribute software through any other system and a licensee cannot impose that choice.

This section is intended to make thoroughly clear what is believed to be a consequence of the rest of this License.

8. If the distribution and/or use of the Program is restricted in certain countries either by patents or by copyrighted interfaces, the original copyright holder who places the Program under this License may add an explicit geographical distribution limitation excluding those countries, so that distribution is permitted only in or among countries not thus excluded. In such case, this License incorporates the limitation as if written in the body of this License.

9. The Free Software Foundation may publish revised and/or new versions of the General Public License from time to time. Such new versions will be similar in spirit to the present version, but may differ in detail to address new problems or concerns.

Each version is given a distinguishing version number. If the Program specifies a version number of this License which applies to it and "any later version", you have the option of following the terms and conditions either of that version or of any later version published by the Free Software Foundation. If the Program does not specify a version number of this License, you may choose any version ever published by the Free Software Foundation.

10. If you wish to incorporate parts of the Program into other free programs whose distribution conditions are different, write to the author to ask for permission. For software which is copyrighted by the Free Software Foundation, write to the Free Software Foundation; we sometimes make exceptions for this. Our decision will be guided by the two goals of preserving the free status of all derivatives of our free software and of promoting the sharing and reuse of software generally.

NO WARRANTY

11. BECAUSE THE PROGRAM IS LICENSED FREE OF CHARGE, THERE IS NO WARRANTY FOR THE PROGRAM, TO THE EXTENT PERMITTED BY APPLICABLE LAW. EXCEPT WHEN OTHERWISE STATED IN WRITING THE COPYRIGHT HOLDERS AND/OR OTHER PARTIES PROVIDE THE PROGRAM "AS IS" WITHOUT WARRANTY OF ANY KIND, EITHER EXPRESSED OR IMPLIED, INCLUDING, BUT NOT LIMITED TO, THE IMPLIED WARRANTIES OF MERCHANTABILITY AND FITNESS FOR A PARTICULAR PURPOSE. THE ENTIRE RISK AS TO THE QUALITY AND PERFORMANCE OF THE PROGRAM IS WITH YOU. SHOULD THE PROGRAM PROVE DEFECTIVE, YOU ASSUME THE COST OF ALL NECESSARY SERVICING, REPAIR OR CORRECTION.

12. IN NO EVENT UNLESS REQUIRED BY APPLICABLE LAW OR AGREED TO IN WRITING WILL ANY COPYRIGHT HOLDER, OR ANY OTHER PARTY WHO MAY MODIFY AND/OR REDISTRIBUTE THE PROGRAM AS PERMITTED ABOVE, BE LIABLE TO YOU FOR DAMAGES, INCLUDING ANY GENERAL, SPECIAL, INCIDENTAL OR CONSEQUENTIAL DAMAGES ARISING OUT OF THE USE OR INABILITY TO USE THE PROGRAM (INCLUDING BUT NOT LIMITED TO LOSS OF DATA OR DATA BEING RENDERED INACCURATE OR LOSSES SUSTAINED BY YOU OR THIRD PARTIES OR A FAILURE OF THE PROGRAM TO OPERATE WITH ANY OTHER PROGRAMS), EVEN IF SUCH HOLDER OR OTHER PARTY HAS BEEN ADVISED OF THE POSSIBILITY OF SUCH DAMAGES.

END OF TERMS AND CONDITIONS

How to Apply These Terms to Your New Programs

If you develop a new program, and you want it to be of the greatest possible use to the public, the best way to achieve this is to make it free software which everyone can redistribute and change under these terms.

To do so, attach the following notices to the program. It is safest to attach them to the start of each source file to most effectively convey the exclusion of warranty; and each file should have at least the "copyright" line and a pointer to where the full notice is found.

<one line to give the program's name and a brief idea of what it does.>
Copyright (C) <year> <name of author>

This program is free software; you can redistribute it and/or modify it under the terms of the GNU General Public License as published by the Free Software Foundation; either version 2 of the License, or (at your option) any later version.

This program is distributed in the hope that it will be useful, but WITHOUT ANY WARRANTY; without even the implied warranty of MERCHANTABILITY or FITNESS FOR A PARTICULAR PURPOSE. See the GNU General Public License for more details.

You should have received a copy of the GNU General Public License along with this program; if not, write to the Free Software Foundation, Inc., 51 Franklin Street, Fifth Floor, Boston, MA 02110-1301 USA.

Also add information on how to contact you by electronic and paper mail.

If the program is interactive, make it output a short notice like this when it starts in an interactive mode:

```
Gnomovision version 69, Copyright (C) year name of author Gnomovision
comes with ABSOLUTELY NO WARRANTY; for details type `show w'.
This is free software, and you are welcome to redistribute it under certain
conditions; type `show c' for details.
```

The hypothetical commands `show w' and `show c' should show the appropriate parts of the General Public License. Of course, the commands you use may be called something other than `show w' and `show c'; they could even be mouse-clicks or menu items--whatever suits your program.

You should also get your employer (if you work as a programmer) or your school, if any, to sign a "copyright disclaimer" for the program, if necessary. Here is a sample; alter the names:

```
Yooyodine, Inc., hereby disclaims all copyright interest in the program
`Gnomovision' (which makes passes at compilers) written by James Hacker.
```

```
<signature of Ty Coon>, 1 April 1989
Ty Coon, President of Vice
```

This General Public License does not permit incorporating your program into proprietary programs. If your program is a subroutine library, you may consider it more useful to permit linking proprietary applications with the library. If this is what you want to do, use the GNU Lesser General Public License instead of this License.

This document contains certain notices that Qualcomm Connected Experiences, Inc. ("QCE") is required to provide you regarding software components included with the software provided herein. Notwithstanding anything in the notices in this file, your use of these software components together with the QCE software (hereinafter referred to as "Software") is subject to the terms of your license from QCE or its affiliates, as the case may be. Compliance with all copyright laws and license terms included in the notice section of this file are the responsibility of the user. Except as may be granted under a copyright license by separate express written agreement, this file provides no rights under or license to any QCE or its affiliate's patents, trademarks, copyrights, or other intellectual property. No part of the Software is a Contribution and QCE has made no Contribution under the Apache 2.0 license. Notifications and licenses are retained for attribution purposes only.

If the version of this software you are using is for running on iOS, it is developed using unmodified iOS SDK header files included in Apple's iOS SDK and such use is not a Modification.

```
Copyright (c) 2013-2014 Qualcomm Connected Experiences, Inc.
All rights reserved. Confidential and Proprietary.
QUALCOMM is a trademark of Qualcomm Incorporated. Other trademarks are
the property of their respective owners.
```

```
Copyright AllSeen Alliance. All rights reserved.
```

```
Permission to use, copy, modify, and/or distribute this software for any purpose
with or without fee is hereby granted, provided that the above copyright notice
and this permission notice appear in all copies.
```

```
THE SOFTWARE IS PROVIDED "AS IS" AND THE AUTHOR DISCLAIMS ALL
WARRANTIES WITH REGARD TO THIS SOFTWARE INCLUDING ALL
IMPLIED WARRANTIES OF MERCHANTABILITY AND FITNESS. IN NO EVENT
SHALL THE AUTHOR BE LIABLE FOR ANY SPECIAL, DIRECT, INDIRECT, OR
CONSEQUENTIAL DAMAGES OR ANY DAMAGES WHATSOEVER
RESULTING FROM LOSS OF USE, DATA OR PROFITS, WHETHER IN AN
ACTION OF CONTRACT, NEGLIGENCE OR OTHER TORTIOUS ACTION,
ARISING OUT OF OR IN CONNECTION WITH THE USE OR PERFORMANCE
OF THIS SOFTWARE.
```

```
Boost Software License - Version 1.0 - August 17th, 2003
```

```
Permission is hereby granted, free of charge, to any person or organization
obtaining a copy of the software and accompanying documentation covered by
this license (the "Software") to use, reproduce, display, distribute, execute,
and transmit the Software, and to prepare derivative works of the Software, and to
permit third-parties to whom the Software is furnished to do so, all subject to the
following:
```

The copyright notices in the Software and this entire statement, including the above license grant, this restriction and the following disclaimer, must be included in all copies of the Software, in whole or in part, and all derivative works of the Software, unless such copies or derivative works are solely in the form of machine-executable object code generated by a source language processor.

```
THE SOFTWARE IS PROVIDED "AS IS", WITHOUT WARRANTY OF ANY
KIND, EXPRESS OR IMPLIED, INCLUDING BUT NOT LIMITED TO THE
WARRANTIES OF MERCHANTABILITY, FITNESS FOR A PARTICULAR
PURPOSE, TITLE AND NON-INFRINGEMENT. IN NO EVENT SHALL THE
COPYRIGHT HOLDERS OR ANYONE DISTRIBUTING THE SOFTWARE BE
LIABLE FOR ANY DAMAGES OR OTHER LIABILITY, WHETHER IN
CONTRACT, TORT OR OTHERWISE, ARISING FROM, OUT OF OR IN
CONNECTION WITH THE SOFTWARE OR THE USE OR OTHER DEALINGS
IN THE SOFTWARE.
```

```
=====
// Copyright (c) 2001-2009 Peter Dimov
// Distributed under the Boost Software License, Version 1.0.
// See accompanying file LICENSE_1_0.txt or copy at
// http://www.boost.org/LICENSE_1_0.txt
// See http://www.boost.org/libs/smart_ptr/weak_ptr.htm for documentation.
//
```

```
=====
// Copyright Douglas Gregor 2001-2004. Use, modification and
// distribution is subject to the Boost Software License, Version
// 1.0. (See accompanying file LICENSE_1_0.txt or copy at
// http://www.boost.org/LICENSE_1_0.txt)
```

```
=====
// Copyright (C) 2007, 2008 Steven Watanabe, Joseph Gauterin, Niels Dekker
// Distributed under the Boost Software License, Version 1.0. (See
// accompanying file LICENSE_1_0.txt or copy at
// http://www.boost.org/LICENSE_1_0.txt)
// For more information, see http://www.boost.org
```

```
=====
// Copyright (C) 2003, Fernando Luis Cacciola Carballal.
// Copyright (C) 2007, Tobias Schwinger.
// Use, modification, and distribution is subject to the Boost Software
// License, Version 1.0. (See accompanying file LICENSE_1_0.txt or copy at
// http://www.boost.org/LICENSE_1_0.txt)
```

```
=====
// Copyright 2003 (c) The Trustees of Indiana University.
// Use, modification, and distribution is subject to the Boost Software
// License, Version 1.0. (See accompanying file LICENSE_1_0.txt or copy at
// http://www.boost.org/LICENSE_1_0.txt)
```

```
=====
// Copyright (C) 2003, Fernando Luis Cacciola Carballal.
// Copyright (C) 2007, Tobias Schwinger.
// Use, modification, and distribution is subject to the Boost Software
// License, Version 1.0. (See accompanying file LICENSE_1_0.txt or copy at
// http://www.boost.org/LICENSE_1_0.txt)
```

```
=====
// See http://www.boost.org/libs/optional for documentation.
// You are welcome to contact the author at:
// fernando_cacciola@hotmail.com
//
```

```
=====
// Copyright 2010 Vicente J. Botet Escriba
// Distributed under the Boost Software License, Version 1.0.
// See http://www.boost.org/LICENSE_1_0.txt
```

```
=====
// Copyright (C) 2003, 2008 Fernando Luis Cacciola Carballal.
// Use, modification, and distribution is subject to the Boost Software
// License, Version 1.0. (See accompanying file LICENSE_1_0.txt or copy at
// http://www.boost.org/LICENSE_1_0.txt)
// See http://www.boost.org/libs/optional for documentation.
//
```

```

// You are welcome to contact the author at:
// fernando_cacciola@hotmail.com
//
=====
// Copyright 2001, 2003, 2004 Daryle Walker. Use, modification, and
// distribution are subject to the Boost Software License, Version 1.0. (See
// accompanying file LICENSE_1_0.txt or copy at
// <http://www.boost.org/LICENSE_1_0.txt>.)
=====

// Copyright (C) 2002 Brad King (brad.king@kitware.com)
// Douglas Gregor (gregod@cs.rpi.edu)
//
// Copyright (C) 2002, 2008 Peter Dimov
//
// Distributed under the Boost Software License, Version 1.0. (See
// accompanying file LICENSE_1_0.txt or copy at
// http://www.boost.org/LICENSE_1_0.txt)

// For more information, see http://www.boost.org
=====

// (C) Copyright John Maddock 2000.
// Use, modification and distribution are subject to the Boost Software License,
// Version 1.0. (See accompanying file LICENSE_1_0.txt or copy at
// http://www.boost.org/LICENSE_1_0.txt).
//
// See http://www.boost.org/libs/type_traits for most recent version including
documentation.
=====

// (C) Copyright Steve Cleary, Beman Dawes, Howard Hinnant & John Maddock
2000.
// Use, modification and distribution are subject to the Boost Software License,
// Version 1.0. (See accompanying file LICENSE_1_0.txt or copy at
// http://www.boost.org/LICENSE_1_0.txt).
//
// See http://www.boost.org/libs/type_traits for most recent version including
documentation.
=====

// (C) Copyright Dave Abrahams, Steve Cleary, Beman Dawes, Howard
// Hinnant & John Maddock 2000.
// Use, modification and distribution are subject to the Boost Software License,
// Version 1.0. (See accompanying file LICENSE_1_0.txt or copy at
// http://www.boost.org/LICENSE_1_0.txt).
//
// See http://www.boost.org/libs/type_traits for most recent version including
documentation.
=====

// (C) Copyright Dave Abrahams, Steve Cleary, Beman Dawes,
// Howard Hinnant and John Maddock 2000-2003.
// (C) Copyright Mat Marcus, Jesse Jones and Adobe Systems Inc 2001

// Use, modification and distribution are subject to the Boost Software License,
// Version 1.0. (See accompanying file LICENSE_1_0.txt or copy at
// http://www.boost.org/LICENSE_1_0.txt).
//
// See http://www.boost.org/libs/type_traits for most recent version including
documentation.
=====

// Copyright 2000 John Maddock (john@johnmaddock.co.uk)
// Copyright 2002 Aleksey Gurtovoy (agurtovoy@meta-comm.com)
//
// Use, modification and distribution are subject to the Boost Software License,
// Version 1.0. (See accompanying file LICENSE_1_0.txt or copy at
// http://www.boost.org/LICENSE_1_0.txt).
//
=====

// Copyright 2000 John Maddock (john@johnmaddock.co.uk)
// Copyright 2000 Jeremy Siek (jsiek@lsc.nd.edu)
// Copyright 1999, 2000 Jaakko Jarvi (jaakko.jarvi@cs.utu.fi)
//
// Use, modification and distribution are subject to the Boost Software License,
// Version 1.0. (See accompanying file LICENSE_1_0.txt or copy at
// http://www.boost.org/LICENSE_1_0.txt).
=====

// Copyright (c) 2001, 2002, 2003 Peter Dimov and Multi Media Ltd.
// Copyright 2004-2005 Peter Dimov
//
// Distributed under the Boost Software License, Version 1.0. (See
// accompanying file LICENSE_1_0.txt or copy at
// http://www.boost.org/LICENSE_1_0.txt)
=====

// Copyright (c) 2009, Spirent Communications, Inc.
//
// Distributed under the Boost Software License, Version 1.0. (See
// accompanying file LICENSE_1_0.txt or copy at
// http://www.boost.org/LICENSE_1_0.txt)
=====

// (C) Copyright 2002 Rani Sharoni (rani_sharoni@hotmail.com) and Robert Ramey
// Use, modification and distribution is subject to the Boost Software
// License, Version 1.0. (See accompanying file LICENSE_1_0.txt or copy at
=====

```



```

=====
// (See accompanying file LICENSE_1_0.txt or copy at
// http://www.boost.org/LICENSE_1_0.txt)
=====
// Copyright (c) 2001, 2002, 2003 Peter Dimov and Multi Media Ltd.
//
// Distributed under the Boost Software License, Version 1.0. (See
// accompanying file LICENSE_1_0.txt or copy at
// http://www.boost.org/LICENSE_1_0.txt)
//
=====
// Copyright (C) 1999, 2000 Jaakko Jarvi (jaakko.jarvi@cs.utu.fi)
// Copyright (C) 2001, 2002 Peter Dimov
// Copyright (C) 2002 David Abrahams
//
// Distributed under the Boost Software License, Version 1.0. (See
// accompanying file LICENSE_1_0.txt or copy at
// http://www.boost.org/LICENSE_1_0.txt)
=====
// (C) Copyright John maddock 1999.
// (C) David Abrahams 2002. Distributed under the Boost
// Software License, Version 1.0. (See accompanying file
// LICENSE_1_0.txt or copy at http://www.boost.org/LICENSE_1_0.txt)
//
=====
# /*
# *
# * (C) Copyright Edward Diener 2011.
# * (C) Copyright Paul Mensonides 2011.
# * Distributed under the Boost Software License, Version 1.0. (See
# * accompanying file LICENSE_1_0.txt or copy at
# * http://www.boost.org/LICENSE_1_0.txt)
# *
# * ..... */
#
=====
// (C) Copyright David Abrahams 2002.
// (C) Copyright Jeremy Siek 2002.
// (C) Copyright Thomas Witt 2002.
// Distributed under the Boost Software License, Version 1.0. (See
// accompanying file LICENSE_1_0.txt or copy at
// http://www.boost.org/LICENSE_1_0.txt)
=====
// (C) Copyright Jeremy Siek 2002.
// Distributed under the Boost Software License, Version 1.0. (See
// accompanying file LICENSE_1_0.txt or copy at
// http://www.boost.org/LICENSE_1_0.txt)
=====
# /* Copyright (C) 2001
# * Housemarque Oy
# * http://www.housemarque.com
# *
# * Distributed under the Boost Software License, Version 1.0. (See
# * accompanying file LICENSE_1_0.txt or copy at
# * http://www.boost.org/LICENSE_1_0.txt)
# */
# /* Revised by Paul Mensonides (2002-2011) */
# /* Revised by Edward Diener (2011) */
#
=====
// Copyright 2002, 2005 Daryle Walker. Use, modification, and distribution are
// subject
// to the Boost Software License, Version 1.0. (See accompanying file
// LICENSE_1_0.txt or a copy at <http://www.boost.org/LICENSE_1_0.txt>.)
=====
# /*
# * (C) Copyright Paul Mensonides 2002-2011.
# * (C) Copyright Edward Diener 2011.
# * Distributed under the Boost Software License, Version 1.0. (See
# * accompanying file LICENSE_1_0.txt or copy at
# * http://www.boost.org/LICENSE_1_0.txt)
# *
# * ..... */
#
=====
// boost integer_traits.hpp header file
#
# * Copyright Jens Maurer 2000
# * Distributed under the Boost Software License, Version 1.0. (See
# * accompanying file LICENSE_1_0.txt or copy at
# * http://www.boost.org/LICENSE_1_0.txt)
=====
// (C) Copyright Dave Abrahams and Daryle Walker 2001. Distributed under the
// Boost
// Software License, Version 1.0. (See accompanying file
// LICENSE_1_0.txt or copy at http://www.boost.org/LICENSE_1_0.txt)
=====
# /*
# * (C) Copyright Paul Mensonides 2002.
# * Distributed under the Boost Software License, Version 1.0. (See
# * accompanying file LICENSE_1_0.txt or copy at
# * http://www.boost.org/LICENSE_1_0.txt)
# *
# * ..... */
#
=====
// Copyright Beman Dawes and Daryle Walker 1999. Distributed under the Boost
// Software License, Version 1.0. (See accompanying file
// LICENSE_1_0.txt or copy at http://www.boost.org/LICENSE_1_0.txt)
=====
// (C) Copyright David Abrahams, Jeremy Siek, Daryle Walker 1999-2001.
// Distributed under the Boost Software License, Version 1.0. (See
// accompanying file LICENSE_1_0.txt or copy at
// http://www.boost.org/LICENSE_1_0.txt)
=====
// Copyright Peter Dimov and David Abrahams 2002.
// Distributed under the Boost Software License, Version 1.0. (See
// accompanying file LICENSE_1_0.txt or copy at
// http://www.boost.org/LICENSE_1_0.txt)
=====
// Copyright 2005-2009 Daniel James.
// Distributed under the Boost Software License, Version 1.0. (See accompanying
// file LICENSE_1_0.txt or copy at http://www.boost.org/LICENSE_1_0.txt)
=====
// Copyright Douglas Gregor 2004.
// Copyright 2005 Peter Dimov
//
// Use, modification and distribution is subject to
// the Boost Software License, Version 1.0.
// (See accompanying file LICENSE_1_0.txt or copy at
// http://www.boost.org/LICENSE_1_0.txt)
=====
// Copyright Peter Dimov 2001-2003
// Copyright Aleksey Gurtovoy 2001-2004
//
// Distributed under the Boost Software License, Version 1.0.
// (See accompanying file LICENSE_1_0.txt or copy at
// http://www.boost.org/LICENSE_1_0.txt)
=====
// Copyright Aleksey Gurtovoy 2002-2006
// Copyright David Abrahams 2002-2003
// Copyright Daniel Walker 2007
//
// Distributed under the Boost Software License, Version 1.0.
=====

```

```

// http://www.boost.org/LICENSE_1_0.txt
=====
// Copyright Douglas Gregor 2001-2006
// Copyright Emil Dotchevski 2007
// Use, modification and distribution is subject to the Boost Software License,
Version 1.0.
// (See accompanying file LICENSE_1_0.txt or copy at
// http://www.boost.org/LICENSE_1_0.txt)
=====
// Copyright Samuel Krempp 2003. Use, modification, and distribution are
// subject to the Boost Software License, Version 1.0. (See accompanying
// file LICENSE_1_0.txt or copy at http://www.boost.org/LICENSE_1_0.txt)
=====
// Copyright Beman Dawes 2002-2005, 2009
// Copyright Vladimir Prus 2002
// Distributed under the Boost Software License, Version 1.0.
// See http://www.boost.org/LICENSE_1_0.txt
=====
// Copyright Beman Dawes 2002-2009
// Copyright Jan Langer 2002
// Copyright Dietmar Kuehl 2001
// Copyright Vladimir Prus 2002
// Distributed under the Boost Software License, Version 1.0.
// See http://www.boost.org/LICENSE_1_0.txt
=====
//Copyright (c) 2006-2009 Emil Dotchevski and Revere Studios, Inc.
//Distributed under the Boost Software License, Version 1.0. (See accompanying
//file LICENSE_1_0.txt or copy at http://www.boost.org/LICENSE_1_0.txt)
=====
// Copyright (c) 2003
// Eric Friedman
//
// Distributed under the Boost Software License, Version 1.0. (See
// accompanying file LICENSE_1_0.txt or copy at
// http://www.boost.org/LICENSE_1_0.txt)
=====
// (C) Copyright 2004 Pavel Vozenilek.
// Use, modification and distribution is subject to the Boost Software
// License, Version 1.0. (See accompanying file LICENSE_1_0.txt
// or copy at http://www.boost.org/LICENSE_1_0.txt)
//
=====
// (C) Copyright Beman Dawes 1999.
// (C) Copyright Jens Maurer 2001
// (C) Copyright John Maddock 2001
// Distributed under the Boost
// Software License, Version 1.0. (See accompanying file
// LICENSE_1_0.txt or copy at http://www.boost.org/LICENSE_1_0.txt)
=====
// Copyright (c) 2001-2003 John Maddock
// Copyright (c) 2001 Darin Adler
// Copyright (c) 2001 Peter Dimov
// Copyright (c) 2002 Bill Kempf
// Copyright (c) 2002 Jens Maurer
// Copyright (c) 2002-2003 David Abrahams
// Copyright (c) 2003 Gennaro Prota
// Copyright (c) 2003 Eric Friedman
// Copyright (c) 2010 Eric Jourdanneau, Joel Falcou
// Distributed under the Boost Software License, Version 1.0. (See
// accompanying file LICENSE_1_0.txt or copy at
// http://www.boost.org/LICENSE_1_0.txt)
=====
// (C) Copyright John Maddock 2001-2003.
// (C) Copyright Jens Maurer 2001-2002.
// Use, modification and distribution are subject to the
// Boost Software License, Version 1.0. (See accompanying file
// LICENSE_1_0.txt or copy at http://www.boost.org/LICENSE_1_0.txt)
=====
// (C) Copyright John Maddock 2001 - 2003.
// (C) Copyright Martin Wille 2003.
// (C) Copyright Guillaume Melquiond 2003.
//
=====
// (C) Copyright John Maddock 2001 - 2003.
// (C) Copyright Darrin Adler 2001 - 2002.
// (C) Copyright Jens Maurer 2001 - 2003.
// (C) Copyright Beman Dawes 2001 - 2003.
// (C) Copyright Douglas Gregor 2002.
// (C) Copyright David Abrahams 2002 - 2003.
// (C) Copyright Syngne Todo 2003.
// Use, modification and distribution are subject to the
// Boost Software License, Version 1.0. (See accompanying file
// LICENSE_1_0.txt or copy at http://www.boost.org/LICENSE_1_0.txt)
=====
// Copyright (c) 2002, 2003 Peter Dimov
// Copyright (c) 2003 Daniel Frey
// Copyright (c) 2003 Howard Hinnant
//
// Distributed under the Boost Software License, Version 1.0. (See
// accompanying file LICENSE_1_0.txt or copy at
// http://www.boost.org/LICENSE_1_0.txt)
//
=====
// Copyright (c) 2001-2004 Peter Dimov and Multi Media Ltd.
// Copyright (c) 2001 David Abrahams
// Copyright (c) 2003-2005 Peter Dimov
//
// Distributed under the Boost Software License, Version 1.0. (See
// accompanying file LICENSE_1_0.txt or copy at
// http://www.boost.org/LICENSE_1_0.txt)
//
=====
// Copyright (c) 2001, 2002 Peter Dimov and Multi Media Ltd.
// Copyright (c) 2007 Peter Dimov
// Copyright (c) Beman Dawes 2011
//
// Distributed under the Boost Software License, Version 1.0. (See
// accompanying file LICENSE_1_0.txt or copy at
// http://www.boost.org/LICENSE_1_0.txt)
//
=====
www.sourceforge.net/projects/boost
Original code (2.0 and earlier) copyright (c) 2000-2006 Lee Thomason
(www.grinninglizard.com)

This software is provided 'as-is', without any express or implied warranty. In no
event will the authors be held liable for any damages arising from the use of this
software.

Permission is granted to anyone to use this software for any purpose, including
commercial applications, and to alter it and redistribute it freely, subject to the
following restrictions:

1. The origin of this software must not be misrepresented; you must not claim that
you wrote the original software. If you use this software in a product, an
acknowledgment in the product documentation would be appreciated but is not
required.

2. Altered source versions must be plainly marked as such, and must not be
misrepresented as being the original software.

3. This notice may not be removed or altered from any source distribution.
=====
libxml2-2.7.8/Copyright

Except where otherwise noted in the source code (e.g. the files hash.c, list.c and
the trio files, which are covered by a similar licence but with different Copyright
notices) all the files are:

Copyright (C) 1998-2003 Daniel Veillard. All Rights Reserved.

Permission is hereby granted, free of charge, to any person obtaining a copy of
this software and associated documentation files (the "Software"), to deal in the
Software without restriction, including without limitation the rights to use, copy,
modify, merge, publish, distribute, sublicense, and/or sell copies of the Software,
and to permit persons to whom the Software is furnished to do so, subject to the
following conditions:

The above copyright notice and this permission notice shall be included in all
copies or substantial portions of the Software.

```

THE SOFTWARE IS PROVIDED "AS IS", WITHOUT WARRANTY OF ANY KIND, EXPRESS OR IMPLIED, INCLUDING BUT NOT LIMITED TO THE WARRANTIES OF MERCHANTABILITY, FITNESS FOR A PARTICULAR PURPOSE AND NONINFRINGEMENT. IN NO EVENT SHALL THE DANIEL VEILLARD BE LIABLE FOR ANY CLAIM, DAMAGES OR OTHER LIABILITY, WHETHER IN AN ACTION OF CONTRACT, TORT OR OTHERWISE, ARISING FROM, OUT OF OR IN CONNECTION WITH THE SOFTWARE OR THE USE OR OTHER DEALINGS IN THE SOFTWARE.

Except as contained in this notice, the name of Daniel Veillard shall not be used in advertising or otherwise to promote the sale, use or other deal-ings in this Software without prior written authorization from him

=====
=====

LICENSE ISSUES

=====

The OpenSSL toolkit stays under a dual license, i.e. both the conditions of the OpenSSL License and the original SSLeay license apply to the toolkit. See below for the actual license texts. Actually both licenses are BSD-style Open Source licenses. In case of any license issues related to OpenSSL please contact openssl-core@openssl.org.

OpenSSL License

/* =====

* Copyright (c) 1998-2011 The OpenSSL Project. All rights reserved.

* Redistribution and use in source and binary forms, with or without
* modification, are permitted provided that the following conditions
* are met:

* 1. Redistributions of source code must retain the above copyright
* notice, this list of conditions and the following disclaimer.
*
* 2. Redistributions in binary form must reproduce the above copyright
* notice, this list of conditions and the following disclaimer in the
* documentation and/or other materials provided with the
* distribution.

* 3. All advertising materials mentioning features or use of this
* software must display the following acknowledgment:
* "This product includes software developed by the OpenSSL Project
* for use in the OpenSSL Toolkit. (<http://www.openssl.org/>)"

* 4. The names "OpenSSL Toolkit" and "OpenSSL Project" must not be used to
* endorse or promote products derived from this software without
* prior written permission. For written permission, please contact
* openssl-core@openssl.org.

* 5. Products derived from this software may not be called "OpenSSL"
* nor may "OpenSSL" appear in their names without prior written
* permission of the OpenSSL Project.

* 6. Redistributions of any form whatsoever must retain the following
* acknowledgment:
* "This product includes software developed by the OpenSSL Project
* for use in the OpenSSL Toolkit (<http://www.openssl.org/>)"

* THIS SOFTWARE IS PROVIDED BY THE OPENSSL PROJECT "AS IS" AND ANY
* IMPLIED WARRANTIES OF MERCHANTABILITY AND FITNESS FOR A PARTICULAR
* PURPOSE ARE DISCLAIMED. IN NO EVENT SHALL THE OPENSSL PROJECT OR
* ITS CONTRIBUTORS BE LIABLE FOR ANY DIRECT, INDIRECT, INCIDENTAL,
* SPECIAL, EXEMPLARY, OR CONSEQUENTIAL DAMAGES (INCLUDING BUT
* NOT LIMITED TO, PROCUREMENT OF SUBSTITUTE GOODS OR SERVICES;
* LOSS OF USE, DATA, OR PROFITS; OR BUSINESS INTERRUPTION)
* HOWEVER CAUSED AND ON ANY THEORY OF LIABILITY, WHETHER IN CONTRACT,
* STRICT LIABILITY, OR TORT (INCLUDING NEGLIGENCE OR OTHERWISE)
* ARISING IN ANY WAY OUT OF THE USE OF THIS SOFTWARE, EVEN IF ADVISED
* OF THE POSSIBILITY OF SUCH DAMAGE.

* This product includes cryptographic software written by Eric Young
* (eay@cryptsoft.com). This product includes software written by Tim
* Hudson (tjh@cryptsoft.com).

*/

=====

Original SSLeay License

/* Copyright (C) 1995-1998 Eric Young (eay@cryptsoft.com)

* All rights reserved.

* This package is an SSL implementation written
* by Eric Young (eay@cryptsoft.com).

* The implementation was written so as to conform with Netscapes SSL.

* This library is free for commercial and non-commercial use as long as
* the following conditions are adhered to. The following conditions

* apply to all code found in this distribution, be it the RC4, RSA,
* lhash, DES, etc., code; not just the SSL code. The SSL documentation
* included with this distribution is covered by the same copyright terms
* except that the holder is Tim Hudson (tjh@cryptsoft.com).

* Copyright remains Eric Young's, and as such any Copyright notices in
* the code are not to be removed.
* If this package is used in a product, Eric Young should be given attribution
* as the author of the parts of the library used.

* This can be in the form of a textual message at program startup or
* in documentation (online or textual) provided with the package.

* Redistribution and use in source and binary forms, with or without
* modification, are permitted provided that the following conditions
* are met:

* 1. Redistributions of source code must retain the copyright
* notice, this list of conditions and the following disclaimer.
* 2. Redistributions in binary form must reproduce the above copyright
* notice, this list of conditions and the following disclaimer in the
* documentation and/or other materials provided with the distribution.
* 3. All advertising materials mentioning features or use of this software
* must display the following acknowledgement:
* "This product includes cryptographic software written by
* Eric Young (eay@cryptsoft.com)"
* The word 'cryptographic' can be left out if the routines from the library
* being used are not cryptographic related :-).
* 4. If you include any Windows specific code (or a derivative thereof) from
* the apps directory (application code) you must include an acknowledgement:
* "This product includes software written by Tim Hudson (tjh@cryptsoft.com)"

* THIS SOFTWARE IS PROVIDED BY ERIC YOUNG "AS IS" AND
* ANY EXPRESS OR IMPLIED WARRANTIES, INCLUDING, BUT NOT LIMITED TO, THE
* IMPLIED WARRANTIES OF MERCHANTABILITY AND FITNESS FOR A PARTICULAR PURPOSE
* ARE DISCLAIMED. IN NO EVENT SHALL THE AUTHOR OR CONTRIBUTORS BE LIABLE
* FOR ANY DIRECT, INDIRECT, INCIDENTAL, SPECIAL, EXEMPLARY, OR CONSEQUENTIAL
* DAMAGES (INCLUDING, BUT NOT LIMITED TO, PROCUREMENT OF SUBSTITUTE GOODS
* OR SERVICES; LOSS OF USE, DATA, OR PROFITS; OR BUSINESS INTERRUPTION)
* HOWEVER CAUSED AND ON ANY THEORY OF LIABILITY, WHETHER IN CONTRACT, STRICT
* LIABILITY, OR TORT (INCLUDING NEGLIGENCE OR OTHERWISE) ARISING IN ANY WAY
* OUT OF THE USE OF THIS SOFTWARE, EVEN IF ADVISED OF THE POSSIBILITY OF
* SUCH DAMAGE.

* The license and distribution terms for any publicly available version or
* derivative of this code cannot be changed, i.e. this code cannot simply be
* copied and put under another distribution licence
* [including the GNU Public License.]

*/

=====

Apache License
Version 2.0, January 2004
<http://www.apache.org/licenses/>

TERMS AND CONDITIONS FOR USE, REPRODUCTION, AND DISTRIBUTION

1. Definitions.

"License" shall mean the terms and conditions for use, reproduction,
and distribution as defined by Sections 1 through 9 of this document.

"Licensor" shall mean the copyright owner or entity authorized by
the copyright owner that is granting the License.

"Legal Entity" shall mean the union of the acting entity and all
other entities that control, are controlled by, or are under common
control with that entity. For the purposes of this definition,
"control" means (i) the power, direct or indirect, to cause the
direction or management of such entity, whether by contract or
otherwise, or (ii) ownership of fifty percent (50%) or more of the
outstanding shares, or (iii) beneficial ownership of such entity.

"You" (or "Your") shall mean an individual or Legal Entity
exercising permissions granted by this License.

"Source" form shall mean the preferred form for making modifications,
including but not limited to software source code, documentation
source, and configuration files.

"Object" form shall mean any form resulting from mechanical
transformation or translation of a Source form, including but
not limited to compiled object code, generated documentation,
and conversions to other media types.

"Work" shall mean the work of authorship, whether in Source or
Object form, made available under the License, as indicated by a
copyright notice that is included in or attached to the work
(an example is provided in the Appendix below).

"Derivative Works" shall mean any work, whether in Source or Object
form, that is based on (or derived from) the Work and for which the
editorial revisions, annotations, elaborations, or other modifications
represent, as a whole, an original work of authorship. For the purposes

of this License, Derivative Works shall not include works that remain separable from, or merely link (or bind by name) to the interfaces of, the Work and Derivative Works thereof.

"Contribution" shall mean any work of authorship, including the original version of the Work and any modifications or additions to that Work or Derivative Works thereof, that is intentionally submitted to Licensor for inclusion in the Work by the copyright owner or by an individual or Legal Entity authorized to submit on behalf of the copyright owner. For the purposes of this definition, "submitted" means any form of electronic, verbal, or written communication sent to the Licensor or its representatives, including but not limited to communication on electronic mailing lists, source code control systems, and issue tracking systems that are managed by, or on behalf of, the Licensor for the purpose of discussing and improving the Work, but excluding communication that is conspicuously marked or otherwise designated in writing by the copyright owner as "Not a Contribution."

"Contributor" shall mean Licensor and any individual or Legal Entity on behalf of whom a Contribution has been received by Licensor and subsequently incorporated within the Work.

2. Grant of Copyright License. Subject to the terms and conditions of this License, each Contributor hereby grants to You a perpetual, worldwide, non-exclusive, no-charge, royalty-free, irrevocable copyright license to reproduce, prepare Derivative Works of, publicly display, publicly perform, sublicense, and distribute the Work and such Derivative Works in Source or Object form.

3. Grant of Patent License. Subject to the terms and conditions of this License, each Contributor hereby grants to You a perpetual, worldwide, non-exclusive, no-charge, royalty-free, irrevocable (except as stated in this section) patent license to make, have made, use, offer to sell, sell, import, and otherwise transfer the Work, where such license applies only to those patent claims licensable by such Contributor that are necessarily infringed by their Contribution(s) alone or by combination of their Contribution(s) with the Work to which such Contribution(s) was submitted. If You institute patent litigation against any entity (including a cross-claim or counterclaim in a lawsuit) alleging that the Work or a Contribution incorporated within the Work constitutes direct or contributory patent infringement, then any patent licenses granted to You under this License for that Work shall terminate as of the date such litigation is filed.

4. Redistribution. You may reproduce and distribute copies of the Work or Derivative Works thereof in any medium, with or without modifications, and in Source or Object form, provided that You meet the following conditions:

- (a) You must give any other recipients of the Work or Derivative Works a copy of this License; and
- (b) You must cause any modified files to carry prominent notices stating that You changed the files; and
- (c) You must retain, in the Source form of any Derivative Works that You distribute, all copyright, patent, trademark, and attribution notices from the Source form of the Work, excluding those notices that do not pertain to any part of the Derivative Works; and
- (d) If the Work includes a "NOTICE" text file as part of its distribution, then any Derivative Works that You distribute must include a readable copy of the attribution notices contained within such NOTICE file, excluding those notices that do not pertain to any part of the Derivative Works, in at least one of the following places: within a NOTICE text file distributed as part of the Derivative Works; within the Source form or documentation, if provided along with the Derivative Works; or, within a display generated by the Derivative Works, if and wherever such third-party notices normally appear. The contents of the NOTICE file are for informational purposes only and do not modify the License. You may add Your own attribution notices within Derivative Works that You distribute, alongside or as an addendum to the NOTICE text from the Work, provided that such additional attribution notices cannot be construed as modifying the License.

You may add Your own copyright statement to Your modifications and may provide additional or different license terms and conditions for use, reproduction, or distribution of Your modifications, or for any such Derivative Works as a whole, provided Your use, reproduction, and distribution of the Work otherwise complies with the conditions stated in this License.

5. Submission of Contributions. Unless You explicitly state otherwise, any Contribution intentionally submitted for inclusion in the Work by You to the Licensor shall be under the terms and conditions of this License, without any additional terms or conditions. Notwithstanding the above, nothing herein shall supersede or modify the terms of any separate license agreement you may have executed with Licensor regarding such Contributions.

6. Trademarks. This License does not grant permission to use the trade names, trademarks, service marks, or product names of the Licensor, except as required for reasonable and customary use in describing the origin of the Work and reproducing the content of the NOTICE file.

7. Disclaimer of Warranty. Unless required by applicable law or agreed to in writing, Licensor provides the Work (and each Contributor provides its Contributions) on an "AS IS" BASIS, WITHOUT WARRANTIES OR CONDITIONS OF ANY KIND, either express or implied, including, without limitation, any warranties or conditions of TITLE, NON-INFRINGEMENT, MERCHANTABILITY, or FITNESS FOR A PARTICULAR PURPOSE. You are solely responsible for determining the appropriateness of using or redistributing the Work and assume any risks associated with Your exercise of permissions under this License.

8. Limitation of Liability. In no event and under no legal theory, whether in tort (including negligence), contract, or otherwise, unless required by applicable law (such as deliberate and grossly negligent acts) or agreed to in writing, shall any Contributor be liable to You for damages, including any direct, indirect, special, incidental, or consequential damages of any character arising as a result of this License or out of the use or inability to use the Work (including but not limited to damages for loss of goodwill, work stoppage, computer failure or malfunction, or any and all other commercial damages or losses), even if such Contributor has been advised of the possibility of such damages.

9. Accepting Warranty or Additional Liability. While redistributing the Work or Derivative Works thereof, You may choose to offer, and charge a fee for, acceptance of support, warranty, indemnity, or other liability obligations and/or rights consistent with this License. However, in accepting such obligations, You may act only on Your own behalf and on Your sole responsibility, not on behalf of any other Contributor, and only if You agree to indemnify, defend, and hold each Contributor harmless for any liability incurred by or claims asserted against, such Contributor by reason of your accepting any such warranty or additional liability.

END OF TERMS AND CONDITIONS

=====
generated automatically by alocal 1.11.3 Autoconf
Copyright (C) 1996, 1997, 1998, 1999, 2000, 2001, 2002, 2003, 2004, 2005, 2006, 2007, 2008, 2009, 2010, 2011 Free Software Foundation, Inc.
This file is free software; the Free Software Foundation
gives unlimited permission to copy and/or distribute it,
with or without modifications, as long as this notice is preserved.
This program is distributed in the hope that it will be useful,
but WITHOUT ANY WARRANTY, to the extent permitted by law; without
even the implied warranty of MERCHANTABILITY or FITNESS FOR A
PARTICULAR PURPOSE.

=====
Copyright 2013 jQuery Foundation and other contributors
http://jquery.com/
Permission is hereby granted, free of charge, to any person obtaining a copy of this software and associated documentation files (the "Software"), to deal in the Software without restriction, including without limitation the rights to use, copy, modify, merge, publish, distribute, sublicense, and/or sell copies of the Software, and to permit persons to whom the Software is furnished to do so, subject to the following conditions: The above copyright notice and this permission notice shall be included in all copies or substantial portions of the Software.
THE SOFTWARE IS PROVIDED "AS IS", WITHOUT WARRANTY OF ANY KIND, EXPRESS OR IMPLIED, INCLUDING BUT NOT LIMITED TO THE WARRANTIES OF MERCHANTABILITY, FITNESS FOR A PARTICULAR PURPOSE AND NONINFRINGEMENT. IN NO EVENT SHALL THE AUTHORS OR COPYRIGHT HOLDERS BE LIABLE FOR ANY CLAIM, DAMAGES OR OTHER LIABILITY, WHETHER IN AN ACTION OF CONTRACT, TORT OR OTHERWISE, ARISING FROM, OUT OF OR IN CONNECTION WITH THE SOFTWARE OR THE USE OR OTHER DEALINGS IN THE SOFTWARE.

=====
LuCI - Lua Configuration Interface
Copyright 2008 Steven Barth <stevan@midlink.org>
Copyright 2008-2011 Jo-Philipp Wich <xm@leipzig.freifunk.net>
Licensed under the Apache License, Version 2.0 (the "License");
you may not use this file except in compliance with the License.
You may obtain a copy of the License at
http://www.apache.org/licenses/LICENSE-2.0

=====
LuCI - Lua Configuration Interface
Copyright 2009 Jo-Philipp Wich <xm@subsignal.org>
Licensed under the Apache License, Version 2.0 (the "License");
you may not use this file except in compliance with the License.
You may obtain a copy of the License at
http://www.apache.org/licenses/LICENSE-2.0
=====

COPYRIGHT:

2002 Joseph M. O'Leary. This code is 100% free. Use it anywhere you want. Rewrite it, restructure it, whatever. If you can write software that makes money off of it, good for you. I kinda like capitalism. Please don't blame me if it causes your \$30 billion dollar satellite explode in orbit. If you redistribute it in any form, I'd appreciate it if you would leave this notice here. MIT-Style Notice.

=====
ConfigFile.h

Class for reading named values from configuration files
Richard J. Wagner v2.1 24 May 2004 wagner@umich.edu
Copyright (c) 2004 Richard J. Wagner

Permission is hereby granted, free of charge, to any person obtaining a copy of this software and associated documentation files (the "Software"), to deal in the Software without restriction, including without limitation the rights to use, copy, modify, merge, publish, distribute, sublicense, and/or sell copies of the Software, and to permit persons to whom the Software is furnished to do so, subject to the following conditions:

The above copyright notice and this permission notice shall be included in all copies or substantial portions of the Software.

THE SOFTWARE IS PROVIDED "AS IS", WITHOUT WARRANTY OF ANY KIND, EXPRESS OR IMPLIED, INCLUDING BUT NOT LIMITED TO THE WARRANTIES OF MERCHANTABILITY, FITNESS FOR A PARTICULAR PURPOSE AND NONINFRINGEMENT. IN NO EVENT SHALL THE AUTHORS OR COPYRIGHT HOLDERS BE LIABLE FOR ANY CLAIM, DAMAGES OR OTHER LIABILITY, WHETHER IN AN ACTION OF CONTRACT, TORT OR OTHERWISE, ARISING FROM, OUT OF OR IN CONNECTION WITH THE SOFTWARE OR THE USE OR OTHER DEALINGS IN THE SOFTWARE.

=====
Copyright (c) 1990, 1993

- * The Regents of the University of California. All rights reserved.
- * Redistribution and use in source and binary forms, with or without modification, are permitted provided that the following conditions are met:
 1. Redistributions of source code must retain the above copyright notice, this list of conditions and the following disclaimer.
 2. Redistributions in binary form must reproduce the above copyright notice, this list of conditions and the following disclaimer in the documentation and/or other materials provided with the distribution.
 3. All advertising materials mentioning features or use of this software must display the following acknowledgement:
 - * This product includes software developed by the University of California, Berkeley and its contributors.
 4. Neither the name of the University nor the names of its contributors may be used to endorse or promote products derived from this software without specific prior written permission.

* THIS SOFTWARE IS PROVIDED BY THE REGENTS AND CONTRIBUTORS "AS IS" AND ANY EXPRESS OR IMPLIED WARRANTIES, INCLUDING, BUT NOT LIMITED TO, THE IMPLIED WARRANTIES OF MERCHANTABILITY AND FITNESS FOR A PARTICULAR PURPOSE ARE DISCLAIMED. IN NO EVENT SHALL THE REGENTS OR CONTRIBUTORS BE LIABLE FOR ANY DIRECT, INDIRECT, INCIDENTAL, SPECIAL, EXEMPLARY, OR CONSEQUENTIAL DAMAGES (INCLUDING, BUT NOT LIMITED TO, PROCUREMENT OF SUBSTITUTE GOODS OR SERVICES; LOSS OF USE, DATA, OR PROFITS; OR BUSINESS INTERRUPTION) HOWEVER CAUSED AND ON ANY THEORY OF LIABILITY, WHETHER IN CONTRACT, STRICT LIABILITY, OR TORT (INCLUDING NEGLIGENCE OR OTHERWISE) ARISING IN ANY WAY OUT OF THE USE OF THIS SOFTWARE, EVEN IF ADVISED OF THE POSSIBILITY OF SUCH DAMAGE.

* @(#)if_dl.h 8.1 (Berkeley) 6/10/93
* \$FreeBSD: src/sys/netif_dl.h,v 1.12 2002/05/07 22:14:06 kbyanc Exp \$
*/

=====
Disclaimer: IMPORTANT: This Apple software is supplied to you by Apple Inc. ("Apple") in consideration of your agreement to the following terms, and your use, installation, modification or redistribution of this Apple software constitutes acceptance of these terms. If you do not agree with these terms, please do not use, install, modify or redistribute this Apple software.

In consideration of your agreement to abide by the following terms, and subject to these terms, Apple grants you a personal, non-exclusive license, under Apple's copyrights in this original Apple software (the "Apple Software"), to use, reproduce, modify and redistribute the Apple Software, with or without modifications, in source and/or binary forms; provided that if you redistribute the Apple Software in its entirety and without modifications, you must retain this notice and the following text and disclaimers in all such redistributions of the Apple Software. Neither the name, trademarks, service marks or logos of Apple Inc. may be used to endorse or promote products derived from the Apple Software without specific prior written permission from Apple. Except as expressly stated in this notice, no other rights or licenses, express or implied, are granted by Apple herein, including but not limited to any patent rights that may be infringed by your derivative works or by other works in which the Apple Software may be incorporated.

The Apple Software is provided by Apple on an "AS IS" basis. APPLE MAKES NO WARRANTIES, EXPRESS OR IMPLIED, INCLUDING WITHOUT LIMITATION THE IMPLIED WARRANTIES OF NON-INFRINGEMENT, MERCHANTABILITY AND FITNESS FOR A PARTICULAR PURPOSE,

REGARDING THE APPLE SOFTWARE OR ITS USE AND OPERATION ALONE OR IN COMBINATION WITH YOUR PRODUCTS.

IN NO EVENT SHALL APPLE BE LIABLE FOR ANY SPECIAL, INDIRECT, INCIDENTAL OR CONSEQUENTIAL DAMAGES (INCLUDING, BUT NOT LIMITED TO, PROCUREMENT OF SUBSTITUTE GOODS OR SERVICES; LOSS OF USE, DATA, OR PROFITS; OR BUSINESS INTERRUPTION) ARISING IN ANY WAY OUT OF THE USE, REPRODUCTION, MODIFICATION AND/OR DISTRIBUTION OF THE APPLE SOFTWARE, HOWEVER CAUSED AND WHETHER UNDER THE THEORY OF CONTRACT, TORT (INCLUDING NEGLIGENCE), STRICT LIABILITY OR OTHERWISE, EVEN IF APPLE HAS BEEN ADVISED OF THE POSSIBILITY OF SUCH DAMAGE.

Copyright (C) 2012 Apple Inc. All Rights Reserved.

=====

Copyright (C) 1996, 1997, 1998, 1999, 2000, 2001, 2002, 2003, 2004, # 2005, 2006, 2007, 2008, 2009, 2010, 2011 Free Software Foundation, # Inc.
This file is free software: the Free Software Foundation
gives unlimited permission to copy and/or distribute it,
with or without modifications, as long as this notice is preserved.

This program is distributed in the hope that it will be useful,
but WITHOUT ANY WARRANTY, to the extent permitted by law; without
even the implied warranty of MERCHANTABILITY or FITNESS FOR A
PARTICULAR PURPOSE.
=====

=====
/*
* file spotify_embedded.h
* brief The public Spotify Embedded API
* copyright Copyright 2015 Spotify AB. All rights reserved.
*

* Licensed to the Apache Software Foundation (ASF) under one
* or more contributor license agreements. See the NOTICE file
* distributed with this work for additional information
* regarding copyright ownership. The ASF licenses this file
* to you under the Apache License, Version 2.0 (the
* "License"); you may not use this file except in compliance
* with the License. You may obtain a copy of the License at
*
* http://www.apache.org/licenses/LICENSE-2.0
*

* Unless required by applicable law or agreed to in writing,
* software distributed under the License is distributed on an
* "AS IS" BASIS, WITHOUT WARRANTIES OR CONDITIONS OF ANY
* KIND, either express or implied. See the License for the
* specific language governing permissions and limitations
* under the License.
*/

=====
COPYRIGHT:

2002 Joseph M. O'Leary. This code is 100% free. Use it anywhere you want. Rewrite it, restructure it, whatever. If you can write software that makes money off of it, good for you. I kinda like capitalism. Please don't blame me if it causes your \$30 billion dollar satellite explode in orbit. If you redistribute it in any form, I'd appreciate it if you would leave this notice here.

=====
Copyright (c) 2004 Richard J. Wagner

Permission is hereby granted, free of charge, to any person obtaining a copy of this software and associated documentation files (the "Software"), to deal in the Software without restriction, including without limitation the rights to use, copy, modify, merge, publish, distribute, sublicense, and/or sell copies of the Software, and to permit persons to whom the Software is furnished to do so, subject to the following conditions:

The above copyright notice and this permission notice shall be included in all copies or substantial portions of the Software.

THE SOFTWARE IS PROVIDED "AS IS", WITHOUT WARRANTY OF ANY KIND, EXPRESS OR IMPLIED, INCLUDING BUT NOT LIMITED TO THE WARRANTIES OF MERCHANTABILITY, FITNESS FOR A PARTICULAR PURPOSE AND NONINFRINGEMENT. IN NO EVENT SHALL THE AUTHORS OR COPYRIGHT HOLDERS BE LIABLE FOR ANY CLAIM, DAMAGES OR OTHER LIABILITY, WHETHER IN AN ACTION OF CONTRACT, TORT OR OTHERWISE, ARISING FROM, OUT OF OR IN CONNECTION WITH THE SOFTWARE OR THE USE OR OTHER DEALINGS IN THE SOFTWARE.

=====
* Copyright (c) 2000 The NetBSD Foundation, Inc.
* All rights reserved.
*

* This code is derived from software contributed to The NetBSD Foundation
* by Dieter Baron and Thomas Klausner.
*

* Redistribution and use in source and binary forms, with or without modification, are permitted provided that the following conditions are met:

- * 1. Redistributions of source code must retain the above copyright notice, this list of conditions and the following disclaimer.
- * 2. Redistributions in binary form must reproduce the above copyright notice, this list of conditions and the following disclaimer in the documentation and/or other materials provided with the distribution.
- * 3. All advertising materials mentioning features or use of this software must display the following acknowledgement:
 - * This product includes software developed by the NetBSD Foundation, Inc. and its contributors.
- * 4. Neither the name of The NetBSD Foundation nor the names of its contributors may be used to endorse or promote products derived from this software without specific prior written permission.

* THIS SOFTWARE IS PROVIDED BY THE NETBSD FOUNDATION, INC. AND CONTRIBUTORS * "AS IS" AND ANY EXPRESS OR IMPLIED WARRANTIES, INCLUDING BUT NOT LIMITED * TO, THE IMPLIED WARRANTIES OF MERCHANTABILITY AND FITNESS FOR A PARTICULAR * PURPOSE ARE DISCLAIMED. IN NO EVENT SHALL THE FOUNDATION OR CONTRIBUTORS * BE LIABLE FOR ANY DIRECT, INDIRECT, INCIDENTAL, SPECIAL, EXEMPLARY, OR * CONSEQUENTIAL DAMAGES (INCLUDING, BUT NOT LIMITED TO, PROCUREMENT OF * SUBSTITUTE GOODS OR SERVICES; LOSS OF USE, DATA, OR PROFITS; OR BUSINESS * INTERRUPTION) HOWEVER CAUSED AND ON ANY THEORY OF LIABILITY, WHETHER IN * CONTRACT, STRICT LIABILITY, OR TORT (INCLUDING NEGLIGENCE OR OTHERWISE) * ARISING IN ANY WAY OUT OF THE USE OF THIS SOFTWARE, EVEN IF ADVISED OF THE * POSSIBILITY OF SUCH DAMAGE.

=====
 Copyright (c) 2015, Randall Stewart and Michael Tuexen
 All rights reserved.

Redistribution and use in source and binary forms, with or without modification, are permitted provided that the following conditions are met:

- * Redistributions of source code must retain the above copyright notice, this list of conditions and the following disclaimer.
- * Redistributions in binary form must reproduce the above copyright notice, this list of conditions and the following disclaimer in the documentation and/or other materials provided with the distribution.
- * Neither the name of usrsctp nor the names of its contributors may be used to endorse or promote products derived from this software without specific prior written permission.

THIS SOFTWARE IS PROVIDED BY THE COPYRIGHT HOLDERS AND CONTRIBUTORS "AS IS" AND ANY EXPRESS OR IMPLIED WARRANTIES, INCLUDING, BUT NOT LIMITED TO, THE IMPLIED WARRANTIES OF MERCHANTABILITY AND FITNESS FOR A PARTICULAR PURPOSE ARE DISCLAIMED. IN NO EVENT SHALL THE COPYRIGHT HOLDER OR CONTRIBUTORS BE LIABLE FOR ANY DIRECT, INDIRECT, INCIDENTAL, SPECIAL, EXEMPLARY, OR CONSEQUENTIAL DAMAGES (INCLUDING, BUT NOT LIMITED TO, PROCUREMENT OF SUBSTITUTE GOODS OR SERVICES; LOSS OF USE, DATA, OR PROFITS; OR BUSINESS INTERRUPTION) HOWEVER CAUSED AND ON ANY THEORY OF LIABILITY, WHETHER IN CONTRACT, STRICT LIABILITY, OR TORT (INCLUDING NEGLIGENCE OR OTHERWISE) ARISING IN ANY WAY OUT OF THE USE OF THIS SOFTWARE, EVEN IF ADVISED OF THE POSSIBILITY OF SUCH DAMAGE.

=====

Limited Warranty (ONLY FOR AUSTRALIA)

Panasonic Warranty

1. The product is warranted for 12 months from the date of purchase. Subject to the conditions of this warranty Panasonic or its Authorised Service Centre will perform necessary service on the product without charge for parts or labour, if in the opinion of Panasonic, the product is found to be faulty within the warranty period.
2. This warranty only applies to Panasonic products purchased in Australia and sold by Panasonic Australia or its Authorised Distributors or Dealers and only where the products are used and serviced within Australia or its territories. Warranty cover only applies to service carried out by a Panasonic Authorised Service Centre and only if valid proof of purchase is presented when warranty service is requested.
3. This warranty only applies if the product has been installed and used in accordance with the manufacturer's recommendations (as noted in the operating instructions) under normal use and reasonable care (in the opinion of Panasonic). The warranty covers normal domestic use only and does not cover damage, malfunction or failure resulting from use of incorrect voltages, incorrect installation, accident, misuse, neglect, build-up of dirt or dust, abuse, maladjustment of customer controls, mains supply problems, thunderstorm activity, infestation by insects or vermin, tampering or repair by unauthorised persons (including unauthorised alterations), introduction of sand, humidity or liquids, commercial use such as hotel, office, restaurant, or other business or rental use of the product, exposure to abnormally corrosive conditions or any foreign object or matter having entered the product.
4. This warranty does not cover the following items unless the fault or defect existed at the time of purchase:
 - (a) Cabinet Part(s)
 - (b) Video or Audio Tapes
 - (c) SD cards or USB devices
 - (d) User replaceable Batteries
 - (e) DVD, Blu-ray or Recordable Discs
 - (f) Video / Audio Heads from wear and tear in normal use
 - (g) Information stored on Hard Disk Drive, USB stick or SD card
 - (h) DTV reception issues caused by TV Aerial / Cabling / Wall socket(s)etc
5. Some products may be supplied with Ethernet connection hardware. The warranty is limited on such products and will not cover
 - (a) Internet and or DLNA connection / setup related problems
 - (b) Access fees and or charges incurred for internet connection
 - (c) The use of incompatible software or software not specifically stipulated in the product operations manual; and
 - (d) Any indirect or consequential costs associated with the incorrect use or misuse of the hardware, its connection to the internet or any other device.
6. To claim warranty service, when required, you should:
 - Telephone Panasonic's Customer Care Centre on 132600 or visit our website referred to below and use the Service Centre Locator for the name/address of the nearest Authorised Service Centre.
 - Send or take the product to a Panasonic Authorised Service Centre together with your proof of purchase receipt as a proof of purchase date. Please note that freight and insurance to and / or from your nearest Authorised Service Centre must be arranged by you.
 - Note that home or pick-up/delivery service is available for the following products in the major metropolitan areas of Australia or the normal operating areas of the nearest Authorised Service Centres:
 - Plasma/LCD televisions / displays (screen size greater than 103 cm)
7. The warranties hereby conferred do not extend to, and exclude, any costs associated with the installation, de-installation or re-installation of a product, including costs related to the mounting, de-mounting or remounting of any screen, (and any other ancillary activities), delivery, handling, freighting, transportation or insurance of the product or any part thereof or replacement of and do not extend to, and exclude, any damage or loss occurring by reason of, during, associated with, or related to such installation, de-installation, re-installation or transit.

Panasonic Authorised Service Centres are located in major metropolitan areas and most regional centres of Australia, however, coverage will vary dependant on product. For advice on exact Authorised Service Centre locations for your product, please telephone our Customer Care Centre on 132600 or visit our website and use the Service Centre Locator.

In addition to your rights under this warranty, Panasonic products come with consumer guarantees that cannot be excluded under the Australian Consumer Law. If there is a major failure with the product, you can reject the product and elect to have a refund or to have the product replaced or if you wish you may elect to keep the goods and be compensated for the drop in value of the goods. You are also entitled to have the product repaired or replaced if the product fails to be of acceptable quality and the failure does not amount to a major failure.

If there is a major failure in regard to the product which cannot be remedied then you must notify us within a reasonable period by contacting the Panasonic Customer Care Centre. If the failure in the product is not a major failure then Panasonic may choose to repair or replace the product and will do so in a reasonable period of time from receiving notice from you.

**THIS WARRANTY CARD AND THE PURCHASE DOCKET (OR SIMILAR PROOF OF PURCHASE)
SHOULD BE RETAINED BY THE CUSTOMER AT ALL TIMES**

If you require assistance regarding warranty conditions or any other enquiries, please visit the **Panasonic Australia** website www.panasonic.com.au or contact by phone on **132 600**
If phoning in, please ensure you have your operating instructions available.

Panasonic Australia Pty. Limited

ACN 001 592 187 ABN 83 001 592 187

1 Innovation Road, Macquarie Park NSW 2113

For the United Kingdom and Ireland customers

Sales and Support Information

Customer Communications Centre

- For customers within the UK: 0344 844 3899
- For customers within Ireland: 01 289 8333
- Monday–Friday 9:00 am – 5:00 pm (Excluding public holidays).
- For further support on your product, please visit our website:
www.panasonic.co.uk

Direct Sales at Panasonic UK

- Order accessory and consumable items for your product with ease and confidence by phoning our Customer Communications Centre Monday–Friday 9:00 am – 5:00 pm (Excluding public holidays).
- Or go on line through our Internet Accessory ordering application at www.pas-europe.com.
- Most major credit and debit cards accepted.
- All enquiries transactions and distribution facilities are provided directly by Panasonic UK.
- It couldn't be simpler!
- Also available through our Internet is direct shopping for a wide range of finished products. Take a browse on our website for further details.

Safety information for customers in Norway

NORSK

ADVARSEL

Produkt

- For å redusere faren for brann, elektrisk støt eller skade på apparatet:
 - Ikke la det komme vann eller annen væske inn i enheten.
 - Ikke utsett tilbehøret (strømledninger, strømadapter osv.) for regn, fuktighet, drypp eller sprut.
 - Ikke sett gjenstander fylt med vann, som f.eks. vaser, på tilbehør.
 - Bruk kun anbefalt tilbehør.
 - Fjern ikke deksler.
 - Reparer ikke denne enheten selv, overlat service til kvalifisert servicepersonell.

Vekselstrømnett

- Nettstøpselet er trukket ut fra denne enheten. Installer denne enheten slik at nettstøpselet umiddelbart kan trekkes fra stikkontakten.

Manufactured by: Panasonic Corporation
Kadoma, Osaka, Japan

Importer for Europe: Panasonic Marketing Europe GmbH
Panasonic Testing Centre
Winsbergring 11, 22525 Hamburg, Germany

FORSIKTIG

Produkt

- Plasser ikke åpen ild, slik som levende lys, oppå apparatet.

Plassering

- For å redusere faren for brann, elektrisk støt eller skade på apparatet:
 - Ikke plasser apparatet i en bokhylle, et innebygget kabinett eller et annet lukket sted. Pass på at produktet er godt ventilert.
 - Apparatets ventilasjonsåpninger må ikke dekkes til med aviser, duker, gardiner eller lignende.

EU



Panasonic Corporation
Web Site: <http://www.panasonic.com>

